



FCC RF Test Report

APPLICANT : Nest Labs Inc.
EQUIPMENT : Outdoor Security Camera
MODEL NAME : Nest Cam IQ
MODEL NUMBER : A0055
FCC ID : ZQANC41
STANDARD : FCC Part 15 Subpart E §15.407
CLASSIFICATION : (NII) Unlicensed National Information Infrastructure

The product was completed on Sep. 07, 2017. We, SPORTON INTERNATIONAL INC., would like to declare that the tested sample has been evaluated in accordance with the test procedures and has been in compliance with the applicable technical standards.

The test results in this report apply exclusively to the tested model / sample. Without written approval of SPORTON INTERNATIONAL INC., the test report shall not be reproduced except in full.

Reviewed by: Joseph Lin / Supervisor

Approved by: Jones Tsai / Manager



Testing Laboratory
1190

SPORTON INTERNATIONAL INC.

No. 52, Hwa Ya 1st Rd., Hwa Ya Technology Park, Kwei-Shan District, Tao Yuan City, Taiwan, R.O.C.



TABLE OF CONTENTS

REVISION HISTORY.....3

SUMMARY OF TEST RESULT4

1 GENERAL DESCRIPTION5

 1.1 Applicant5

 1.2 Product Feature of Equipment Under Test.....5

 1.3 Modification of EUT5

 1.4 Testing Location6

 1.5 Applicable Standards.....6

2 TEST CONFIGURATION OF EQUIPMENT UNDER TEST7

 2.1 Carrier Frequency and Channel7

 2.2 Test Mode.....8

 2.3 Connection Diagram of Test System.....9

 2.4 Support Unit used in test configuration and system 10

 2.5 EUT Operation Test Setup 10

 2.6 Measurement Results Explanation Example..... 10

3 TEST RESULT.....11

 3.1 6dB and 26dB and 99% Occupied Bandwidth Measurement 11

 3.2 Maximum Conducted Output Power Measurement 14

 3.3 Power Spectral Density Measurement 15

 3.4 Unwanted Emissions Measurement 18

 3.5 AC Conducted Emission Measurement..... 23

 3.6 Frequency Stability Measurement 25

 3.7 Automatically Discontinue Transmission 26

 3.8 Antenna Requirements 28

4 LIST OF MEASURING EQUIPMENT29

5 UNCERTAINTY OF EVALUATION30

APPENDIX A. CONDUCTED TEST RESULTS

APPENDIX B. AC CONDUCTED EMISSION TEST RESULT

APPENDIX C. RADIATED SPURIOUS EMISSION

APPENDIX D. RADIATED SPURIOUS EMISSION PLOTS

APPENDIX E. DUTY CYCLE PLOTS



SUMMARY OF TEST RESULT

Report Section	FCC Rule	Description	Limit	Result
3.1	15.403(i)	6dB, 26dB and 99% Occupied Bandwidth	> 500kHz	Pass
3.2	15.407(a)	Maximum Conducted Output Power	≤ 30 dBm	Pass
3.3	15.407(a)	Power Spectral Density	≤ 30 dBm/500kHz	Pass
3.4	15.407(b)	Unwanted Emissions	15.407(b)(4)(i) & 15.209(a)	Pass
3.5	15.207	AC Conducted Emission	15.207(a)	Pass
3.6	15.407(g)	Frequency Stability	Within Operation Band	Pass
3.7	15.407(c)	Automatically Discontinue Transmission	Discontinue Transmission	Pass
3.8	15.203 & 15.407(a)	Antenna Requirement	N/A	Pass



1 General Description

1.1 Applicant

Nest Labs Inc.
3400 Hillview Ave. Palo Alto, CA 94304 USA

1.2 Product Feature of Equipment Under Test

Bluetooth-LE, Wi-Fi 2.4GHz 802.11b/g/n/ac, and Wi-Fi 5GHz 802.11a/n/ac, 15.4.

Product Specification subjective to this standard	
Antenna Type	WLAN: IFA Antenna Bluetooth: IFA Antenna 15.4: IFA Antenna

1.3 Modification of EUT

No modifications are made to the EUT during all test items.



1.4 Testing Location

Sporton Lab is accredited to ISO 17025 by Taiwan Accreditation Foundation (TAF code : 1190) and the FCC designation No. TW0007 under the FCC 2.948(e) by Mutual Recognition Agreement (MRA) in FCC Test.

Test Site	SPORTON INTERNATIONAL INC.	
Test Site Location	No. 52, Hwa Ya 1 st Rd., Hwa Ya Technology Park, Kwei-Shan District, Tao Yuan City, Taiwan, R.O.C. TEL: +886-3-327-3456 FAX: +886-3-328-4978	
Test Site No.	Sporton Site No.	
	TH05-HY	CO05-HY

Note: The test site complies with ANSI C63.4 2014 requirement.

Test Site	SPORTON INTERNATIONAL INC.	
Test Site Location	No.58, Aly. 75, Ln. 564, Wenhua 3rd Rd. Guishan Dist, Taoyuan City, Taiwan (R.O.C.) TEL: +886-3-327-0868 FAX: +886-3-327-0855	
Test Site No.	Sporton Site No.	
	03CH11-HY	

Note: The test site complies with ANSI C63.4 2014 requirement.

1.5 Applicable Standards

According to the specifications of the manufacturer, the EUT must comply with the requirements of the following standards:

- ♦ FCC Part 15 Subpart E
- ♦ FCC KDB 789033 D02 General UNII Test Procedures New Rules v01r04.
- ♦ FCC KDB 662911 D01 Multiple Transmitter Output v02r01.
- ♦ ANSI C63.10-2013

Remark: All test items were verified and recorded according to the standards and without any deviation during the test.



2 Test Configuration of Equipment Under Test

- a. The EUT has been associated with peripherals and configuration operated in a manner tended to maximize its emission characteristics in a typical application. Frequency range investigated: conduction emission (150 kHz to 30 MHz), radiation emission (9 kHz to the 10th harmonic of the highest fundamental frequency or to 40 GHz, whichever is lower). For radiated measurement, pre-scanned in four orthogonal panels, X, Y, Z, Back. The worst cases (Back plane) were recorded in this report.
- b. AC power line Conducted Emission was tested under maximum output power.

2.1 Carrier Frequency and Channel

Frequency Band	Channel	Freq. (MHz)	Channel	Freq. (MHz)
5725-5850 MHz Band 4 (U-NII-3)	149	5745	157	5785
	151*	5755	159*	5795
	153	5765	161	5805
	155#	5775	165	5825

Note:

1. The above Frequency and Channel in "*" were 802.11n HT40 and 802.11ac VHT40.
2. The above Frequency and Channel in "#n" were 802.11ac VHT80.



2.2 Test Mode

Final test mode of conducted test items and radiated spurious emissions are considering the modulation and worse data rates as below table.

MIMO Antenna

Modulation	Data Rate
802.11a	6 Mbps
802.11n HT20	MCS0
802.11n HT40	MCS0
802.11ac VHT20	MCS0
802.11ac VHT40	MCS0
802.11ac VHT80	MCS0

AC Conducted Emission	Mode 1 : WLAN Tx + 15.4 Idle + Speaker on + LED on + RR LED on + IR CUT on + Memory + Camera on + USB Cable (Charging from Adapter 1)
Remark:	
<ol style="list-style-type: none"> For radiated spurious emissions, the tests were performed with USB Cable and Adapter 1. The MIMO conducted total power has larger 3dB than SISO conducted power, the RSE test with MIMO condition can also cover the SISO condition. 	

Ch. #		Band IV : 5725-5850 MHz		
		802.11a	802.11n HT20	802.11n HT40
L	Low	149	149	151
M	Middle	157	157	-
H	High	165	165	159

Ch. #		Band IV : 5725-5850 MHz		
		802.11ac VHT20	802.11ac VHT40	802.11ac VHT80
L	Low	149	151	-
M	Middle	157	-	155
H	High	165	159	-

2.3 Connection Diagram of Test System

<WLAN Tx Mode>

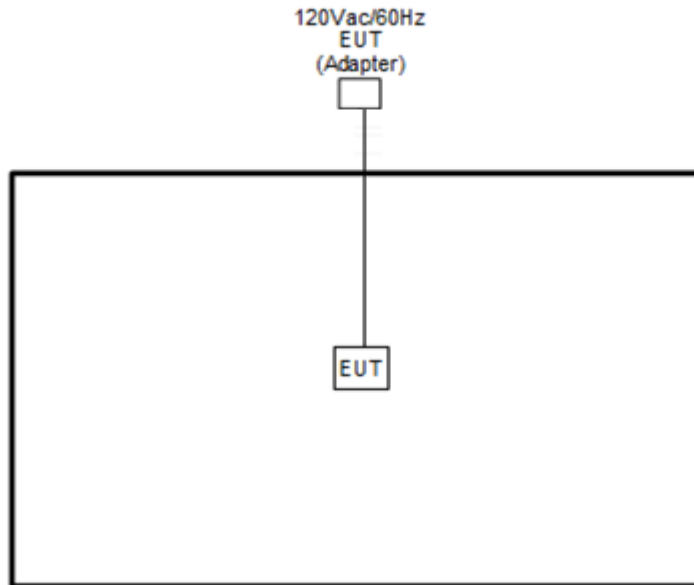

<AC Conducted Emission Mode>

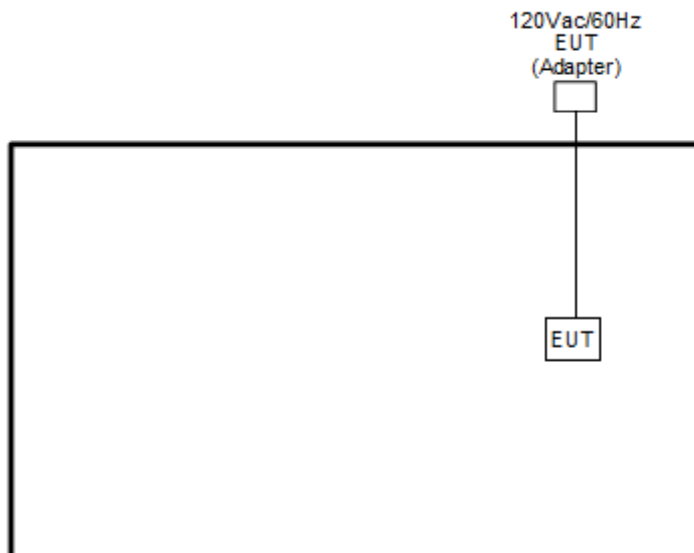

2.4 Support Unit used in test configuration and system

Item	Equipment	Trade Name	Model Name	FCC ID	Data Cable	Power Cord
1.	WLAN AP	ASUS	RT-AC66U	MSQ-RTAC66U	N/A	Unshielded, 1.8 m
2.	Notebook	DELL	Latitude E3340	FCC DoC/ Contains FCC ID: PD97260NGU	N/A	AC I/P: Unshielded, 1.2 m DC O/P: Shielded, 1.8 m
3.	iPod	Apple	A1285	FCC DoC	Shielded, 1.0 m	N/A
4.	USB Cable	N/A	N/A	N/A	Unshielded, 1.93 m	Unshielded, 1.93 m

2.5 EUT Operation Test Setup

The RF test items, programmed RF utility, “CMD” installed in the notebook make the EUT provide functions like channel selection and power level for continuous transmitting and receiving signals.

The laptop used for engineering setting purpose only was removed from the EUT, after configured.

2.6 Measurement Results Explanation Example

For all conducted test items:

The offset level is set in the spectrum analyzer to compensate the RF cable loss and attenuator factor between EUT conducted output port and spectrum analyzer. With the offset compensation, the spectrum analyzer reading level is exactly the EUT RF output level.

Example :

The spectrum analyzer offset is derived from RF cable loss and attenuator factor.

Offset = RF cable loss + attenuator factor.

Following shows an offset computation example with cable loss 4.2 dB and 10dB attenuator.

$$\begin{aligned} \text{Offset(dB)} &= \text{RF cable loss(dB)} + \text{attenuator factor(dB)}. \\ &= 4.2 + 10 = 14.2 \text{ (dB)} \end{aligned}$$

3 Test Result

3.1 6dB and 26dB and 99% Occupied Bandwidth Measurement

3.1.1 Description of 6dB and 26dB and 99% Occupied Bandwidth

The minimum 6 dB bandwidth shall be at least 500 kHz.

26dB and 99% Occupied bandwidth are reporting only.

3.1.2 Measuring Instruments

The measuring equipment is listed in the section 4 of this test report.

3.1.3 Test Procedures

1. The testing follows FCC KDB 789033 D02 General UNII Test Procedures New Rules v01r04.
Section C) Emission bandwidth for the band 5.725-5.85GHz
2. Set RBW = 100kHz.
3. Set the VBW $\geq 3 \times$ RBW.
4. Detector = Peak.
5. Trace mode = max hold
6. Measure the maximum width of the emission that is 6 dB down from the peak of the emission.
7. Measure and record the results in the test report.

3.1.4 Test Setup

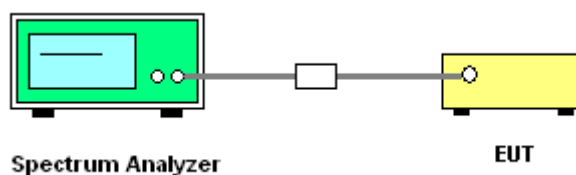

3.1.5 Test Result of 6dB Bandwidth

Please refer to Appendix A.

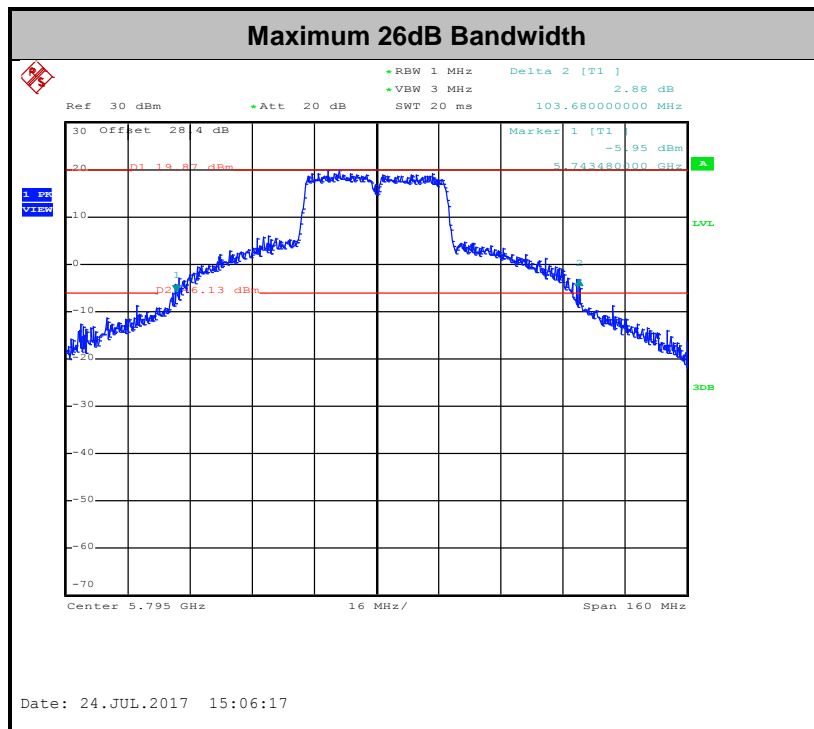
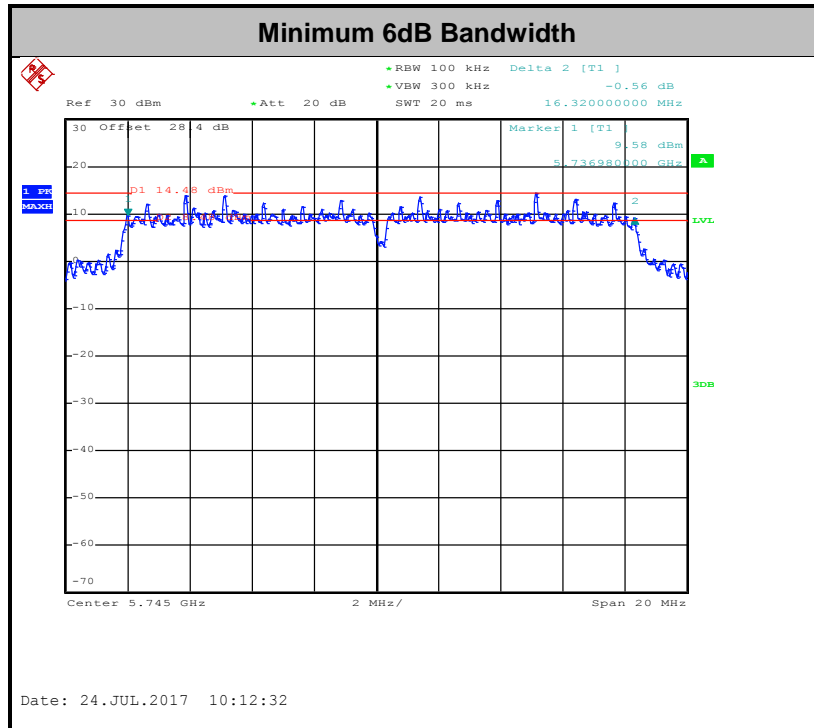

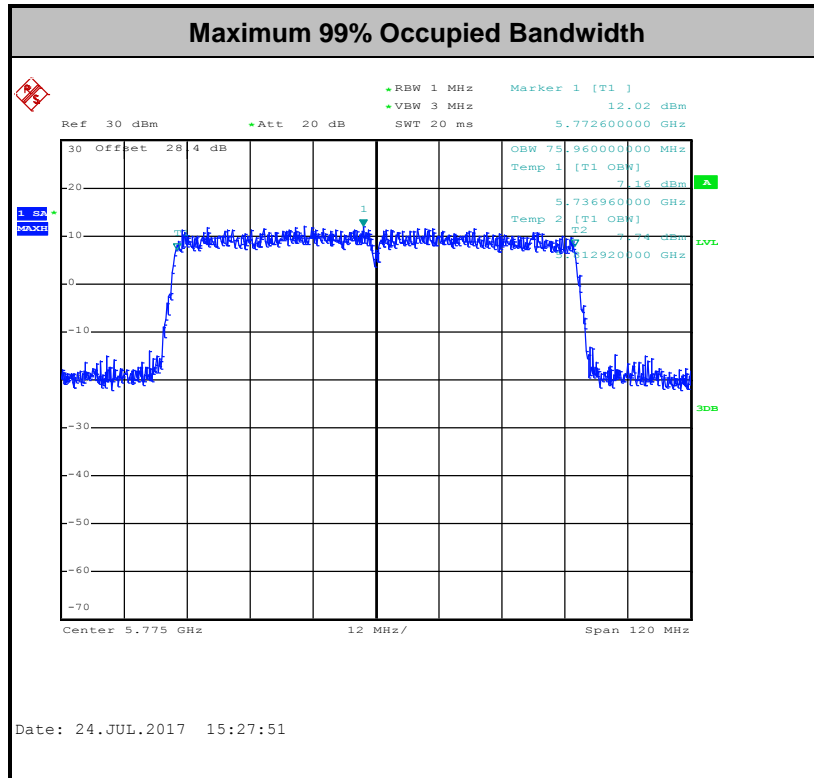

Note: The occupied channel bandwidth is maintained within the band of operation for all of the modulations.

3.2 Maximum Conducted Output Power Measurement

3.2.1 Limit of Maximum Conducted Output Power

For the band 5.725–5.85 GHz, the maximum conducted output power over the frequency band of operation shall not exceed 1 W.

If transmitting antennas of directional gain greater than 6 dBi are used, the peak output power shall be reduced by the amount in dB that the directional gain of the antenna exceeds 6 dBi.

3.2.2 Measuring Instruments

The measuring equipment is listed in the section 4 of this test report.

3.2.3 Test Procedures

CDD modes

The testing follows Method PM of FCC KDB 789033 D02 General UNII Test Procedures New Rules v01r04.

Method PM (Measurement using an RF average power meter):

1. Measurement is performed using a wideband RF power meter.
2. The EUT is configured to transmit continuously with a consistent duty cycle at its maximum power control level.
3. Measure the average power of the transmitter, and the average power is corrected with duty factor, $10 \log(1/x)$, where x is the duty cycle.

3.2.4 Test Setup

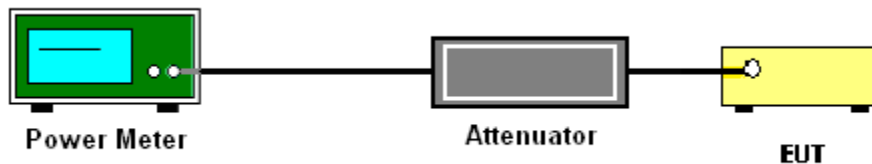

3.2.5 Test Result of Maximum Conducted Output Power

Please refer to Appendix A.



3.3 Power Spectral Density Measurement

3.3.1 Limit of Power Spectral Density

For the band 5.725–5.85 GHz, the maximum power spectral density shall not exceed 30 dBm in any 500-kHz band.

If transmitting antennas of directional gain greater than 6 dBi are used, the peak output power shall be reduced by the amount in dB that the directional gain of the antenna exceeds 6 dBi.

3.3.2 Measuring Instruments

The measuring equipment is listed in the section 4 of this test report.

3.3.3 Test Procedures

The testing follows FCC KDB 789033 D02 General UNII Test Procedures New Rules v01r04. Section F) Maximum power spectral density.

CDD modes

Method SA-2

(trace averaging across on and off times of the EUT transmissions, followed by duty cycle correction).

- Measure the duty cycle.
- Set span to encompass the entire emission bandwidth (EBW) of the signal.
- Set RBW = 300 kHz.
- Set VBW \geq 1 MHz.
- Number of points in sweep \geq 2 Span / RBW.
- Sweep time = auto.
- Detector = RMS
- Trace average at least 100 traces in power averaging mode.
- Add $10 \log(500\text{kHz}/\text{RBW})$ to the test result.
- Add $10 \log(1/x)$, where x is the duty cycle, to the measured power in order to compute the average power during the actual transmission times. For example, add $10 \log(1/0.25) = 6$ dB if the duty cycle is 25 percent.

1. The RF output of EUT was connected to the spectrum analyzer by a low loss cable.
2. Each plot has already offset with cable loss, and attenuator loss. Measure the PPSD and record it.
3. For MIMO mode, calculation method follows FCC KDB 662911 D01 Multiple Transmitter Output v02r01.

Method (c): Measure and add $10 \log(N_{\text{ANT}})$ dB.

With this technique, spectrum measurements are performed at each output of the device, but rather than summing the spectra or the spectral peaks across the outputs, the quantity $10 \log(N_{\text{ANT}})$ dB is added to each spectrum value before comparing to the emission limit. The addition of $10 \log(N_{\text{ANT}})$ dB serves to apportion the emission limit among the N_{ANT} outputs so that each output is permitted to contribute no more than $1/N_{\text{ANT}}^{\text{th}}$ of the PSD limit.

3.3.4 Test Setup

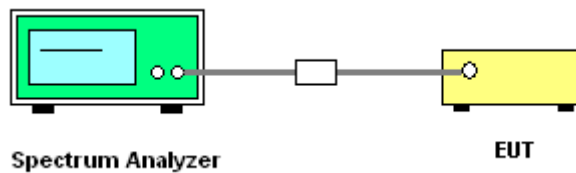

3.3.5 Test Result of Power Spectral Density

Please refer to Appendix A.

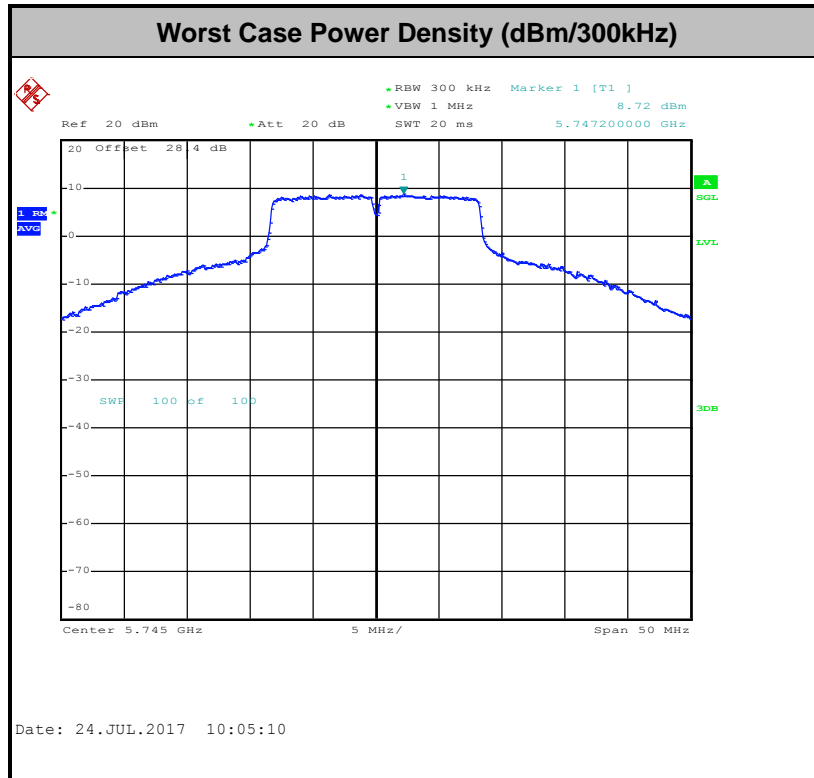



3.4 Unwanted Emissions Measurement

This section is to measure unwanted emissions through radiated measurement for band edge spurious emissions and out of band emissions measurement.

3.4.1 Limit of Unwanted Emissions

(1) For transmitters operating in the 5.725-5.85 GHz band:

15.407(b)(4)(i) All emissions shall be limited to a level of -27 dBm/MHz at 75 MHz or more above or below the band edge increasing linearly to 10 dBm/MHz at 25 MHz above or below the band edge, and from 25 MHz above or below the band edge increasing linearly to a level of 15.6 dBm/MHz at 5 MHz above or below the band edge, and from 5 MHz above or below the band edge increasing linearly to a level of 27 dBm/MHz at the band edge.

(2) Unwanted spurious emissions fallen in restricted bands shall comply with the general field strength limits as below table,

Frequency (MHz)	Field Strength (microvolts/meter)	Measurement Distance (meters)
0.009 – 0.490	2400/F(kHz)	300
0.490 – 1.705	24000/F(kHz)	30
1.705 – 30.0	30	30
30 – 88	100	3
88 – 216	150	3
216 - 960	200	3
Above 960	500	3

Note: The following formula is used to convert the EIRP to field strength.

$$E = \frac{1000000\sqrt{30P}}{3} \text{ } \mu\text{V/m, where P is the eirp (Watts)}$$



EIRP (dBm)	Field Strength at 3m (dBµV/m)
-17	78.3
- 27	68.3

(3) KDB789033 D02 v01r04 G)2)c)

- (i) Sections 15.407(b)(1) to (b)(3) specify the unwanted emission limits for the U-NII-1 and U-NII-2 bands. As specified, emissions above 1000 MHz that are outside of the restricted bands are subject to a peak emission limit of -27 dBm/MHz.³
- (ii) Section 15.407(b)(4) specifies the unwanted emission limit for the U-NII-3 band. A band emissions mask is specified in Section 15.407(b)(4)(i). The emission limits are in terms of a Peak detector. An alternative to the band emissions mask is specified in Section 15.407(b)(4)(ii). The alternative limits are based on the highest antenna gain specified in the filing. There are also marketing and importation restrictions for the devices using the alternative limit.⁴

Note 3: An out-of-band emission that complies with both the average and peak limits of Section 15.209 is not required to satisfy the -27 dBm/MHz peak emission limit.

Note 4: Only devices with antenna gains of 10 dBi or less may be approved using the emission limits specified in Section 15.247(d) till March 2, 2018; all other devices operating in this band must use the mask specified in Section 15.407(b)(4)(i).

3.4.2 Measuring Instruments

The measuring equipment is listed in the section 4 of this test report.

3.4.3 Test Procedures

1. The testing follows FCC KDB 789033 D02 General UNII Test Procedures New Rules v01r04. Section G) Unwanted emissions measurement.
 - (1) Procedure for Unwanted Emissions Measurements Below 1000MHz
 - RBW = 120 kHz
 - VBW = 300 kHz
 - Detector = Peak
 - Trace mode = max hold



(2) Procedure for Peak Unwanted Emissions Measurements Above 1000 MHz

- RBW = 1 MHz
- VBW \geq 3 MHz
- Detector = Peak
- Sweep time = auto
- Trace mode = max hold

(3) Procedures for Average Unwanted Emissions Measurements Above 1000MHz

- RBW = 1 MHz
- VBW = 10 Hz, when duty cycle is no less than 98 percent.
- VBW \geq 1/T, when duty cycle is less than 98 percent where T is the minimum transmission duration over which the transmitter is on and is transmitting at its maximum power control level for the tested mode of operation.

2. The EUT was placed on a turntable with 0.8 meter for frequency below 1GHz and 1.5 meter for frequency above 1GHz respectively above ground.
3. The EUT was set 3 meters from the interference receiving antenna which was mounted on the top of a variable height antenna tower.
4. The antenna is a broadband antenna and its height is adjusted between one meter and four meters above ground to find the maximum value of the field strength for both horizontal polarization and vertical polarization of the antenna.
5. For each suspected emission, the EUT was arranged to its worst case and then adjust the antenna tower (from 1 m to 4 m) and turntable (from 0 degree to 360 degrees) to find the maximum reading.
6. For testing below 1GHz, if the emission level of the EUT in peak mode was 3 dB lower than the limit specified, then peak values of EUT will be reported, otherwise, the emissions will be repeated one by one using the CISPR quasi-peak method and reported.
7. For testing above 1GHz, the emission level of the EUT in peak mode was 20dB lower than average limit (that means the emission level in average mode also complies with the limit in average mode), then peak values of EUT will be reported, otherwise, the emissions will be measured in average mode again and reported.

3.4.4 Test Setup

For radiated emissions below 30MHz

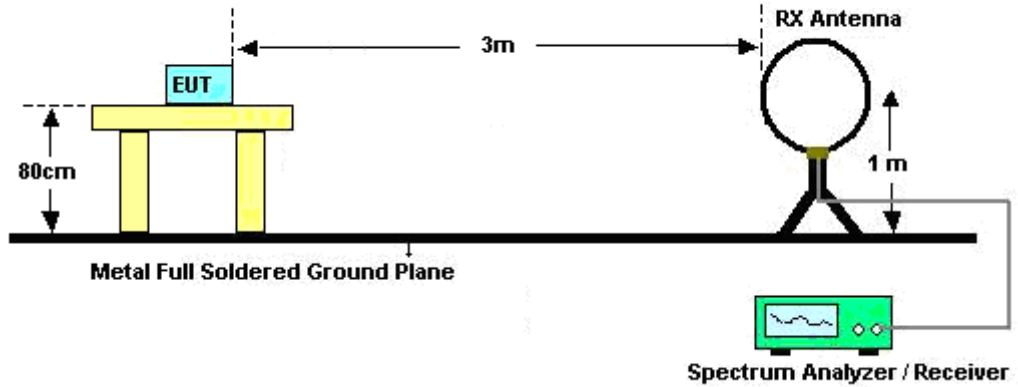

For radiated emissions from 30MHz to 1GHz

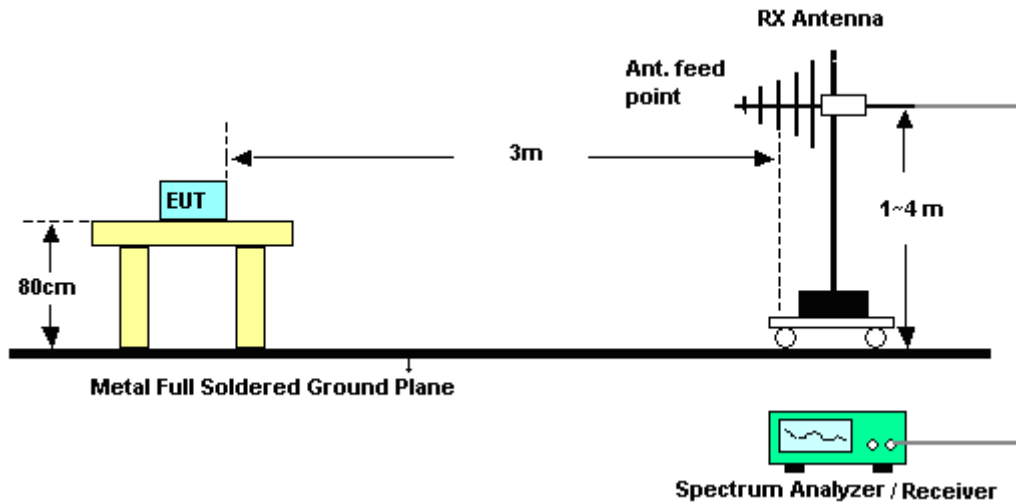

For radiated emissions above 1GHz

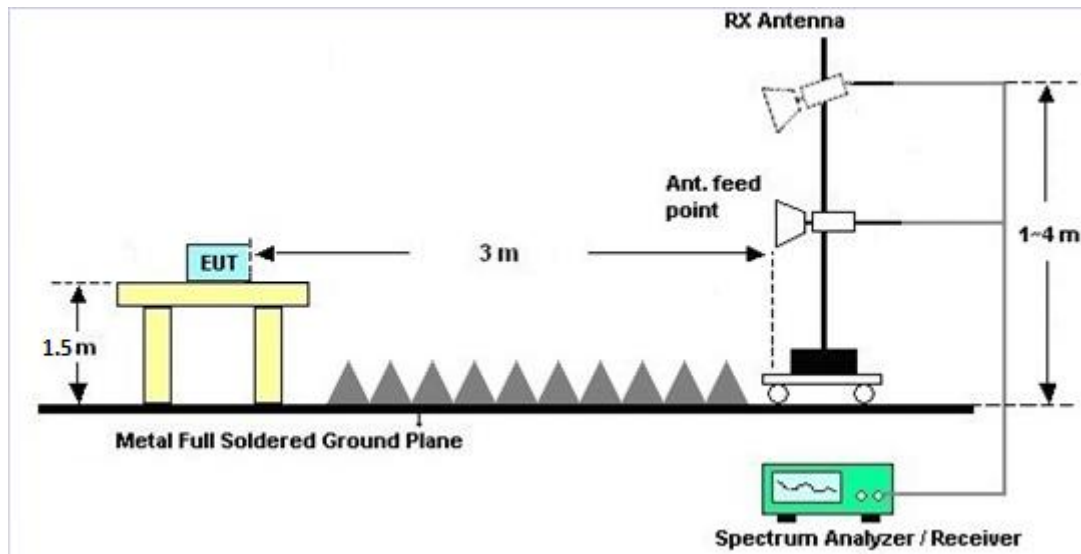

3.4.5 Test Results of Radiated Emissions (9 kHz ~ 30 MHz)

The low frequency, which started from 9 kHz to 30MHz, was pre-scanned and the result which was 20dB lower than the limit line was not reported.

There is a comparison data of both open-field test site and semi-Anechoic chamber, and the result came out very similar.

3.4.6 Test Result of Radiated Band Edges

Please refer to Appendix C and D.

3.4.7 Duty Cycle

Please refer to Appendix E.

3.4.8 Test Result of Unwanted Radiated Emission (30MHz ~ 10th Harmonic)

Please refer to Appendix C and D.



3.5 AC Conducted Emission Measurement

3.5.1 Limit of AC Conducted Emission

For equipment that is designed to be connected to the public utility (AC) power line, the radio frequency voltage that is conducted back onto the AC power line on any frequency or frequencies within the band 150 kHz to 30 MHz shall not exceed the limits in the following table.

Frequency of emission (MHz)	Conducted limit (dB μ V)	
	Quasi-peak	Average
0.15-0.5	66 to 56*	56 to 46*
0.5-5	56	46
5-30	60	50

*Decreases with the logarithm of the frequency.

3.5.2 Measuring Instruments

The measuring equipment is listed in the section 4 of this test report.

3.5.3 Test Procedures

1. The EUT was placed 0.4 meter from the conducting wall of the shielding room was kept at least 80 centimeters from any other grounded conducting surface.
2. Connect EUT to the power mains through a line impedance stabilization network (LISN).
3. All the support units are connecting to the other LISN.
4. The LISN provides 50 ohm coupling impedance for the measuring instrument.
5. The FCC states that a 50 ohm, 50 microhenry LISN should be used.
6. Both sides of AC line were checked for maximum conducted interference.
7. The frequency range from 150 kHz to 30 MHz was searched.
8. Set the test-receiver system to Peak Detect Function and specified bandwidth with Maximum Hold Mode.

3.5.4 Test Setup

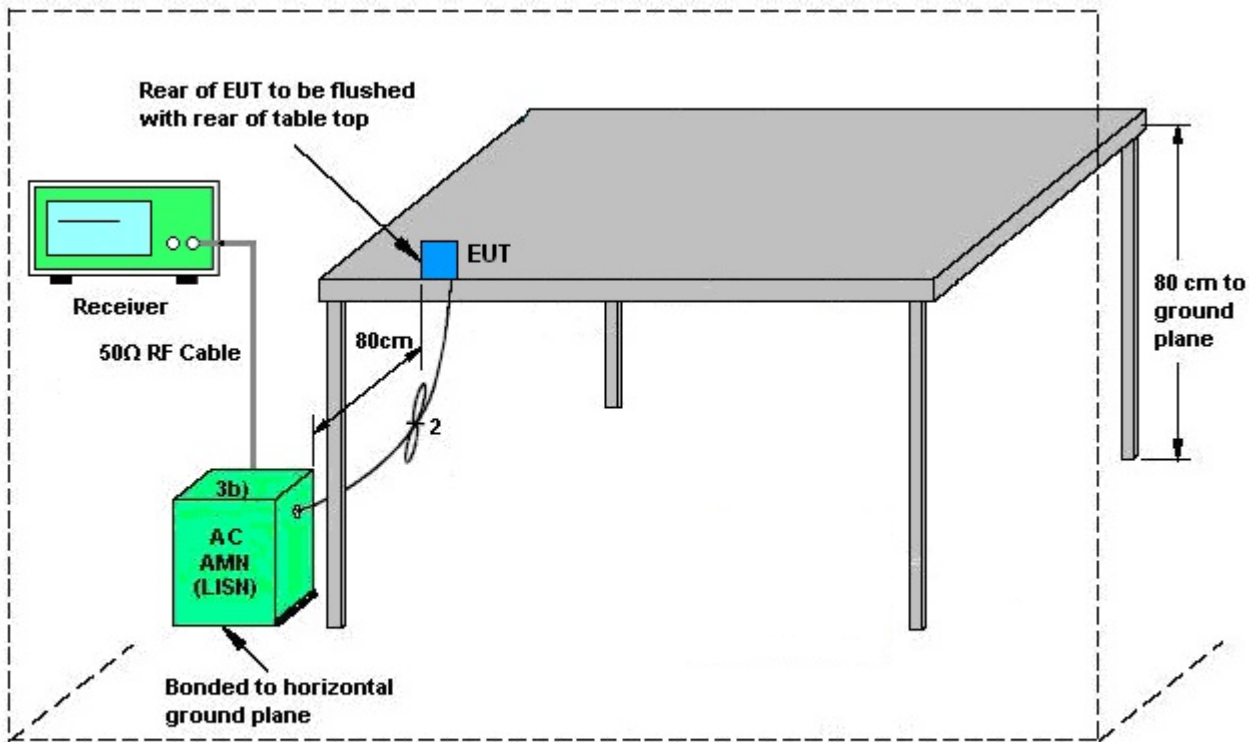

AMN = Artificial mains network (LISN)
 AE = Associated equipment
 EUT = Equipment under test
 ISN = Impedance stabilization network

3.5.5 Test Result of AC Conducted Emission

Please refer to Appendix B.

3.6 Frequency Stability Measurement

3.6.1 Limit of Frequency Stability

Manufacturers of U-NII devices are responsible for ensuring frequency stability such that an emission is maintained within the band of operation under all conditions of normal operation as specified in the user's manual.

3.6.2 Measuring Instruments

The measuring equipment is listed in the section 4 of this test report.

3.6.3 Test Procedures

1. To ensure emission at the band edge is maintained within the authorized band, those values shall be measured by radiation emissions at upper and lower frequency points, and finally compensated by frequency deviation as procedures below.
2. The EUT was operated at the maximum output power, and connected to the spectrum analyzer, which is set to maximum hold function and peak detector. The peak value of the power envelope was measured and noted. The upper and lower frequency points were respectively measured relatively 10dB lower than the measured peak value.
3. The frequency deviation was calculated by adding the upper frequency point and the lower frequency point divided by two. Those detailed values of frequency deviation are provided in table below.
4. Follower ANSI C63.10 : 2013 section 6.8.

3.6.4 Test Setup

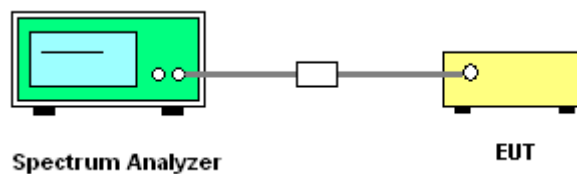

3.6.5 Test Result of Frequency Stability

Please refer to Appendix A.



3.7 Automatically Discontinue Transmission

3.7.1 Limit of Automatically Discontinue Transmission

The device shall automatically discontinue transmission in case of either absence of information to transmit or operational failure. These provisions are not intended to preclude the transmission of control or signaling information or the use of repetitive codes used by certain digital technologies to complete frame or burst intervals. Applicants shall include in their application for equipment authorization to describe how this requirement is met.

3.7.2 Measuring Instruments

The measuring equipment is listed in the section 4 of this test report.

3.7.3 Test Result of Automatically Discontinue Transmission

EUT is verified this characteristic during the function check of normal sample associated with an access point:

- A. Information start: make EUT supply information to the access point.
- B. Information stop: stop supplying information to the access point.

While the EUT is not transmitting any information, the EUT can automatically discontinue transmission and become standby mode for power saving.

- C. Information start: make EUT supply information to the access point again.

The EUT can detect the controlling signal of ACK message transmitting from remote device and verify whether it shall resend or discontinue transmission.

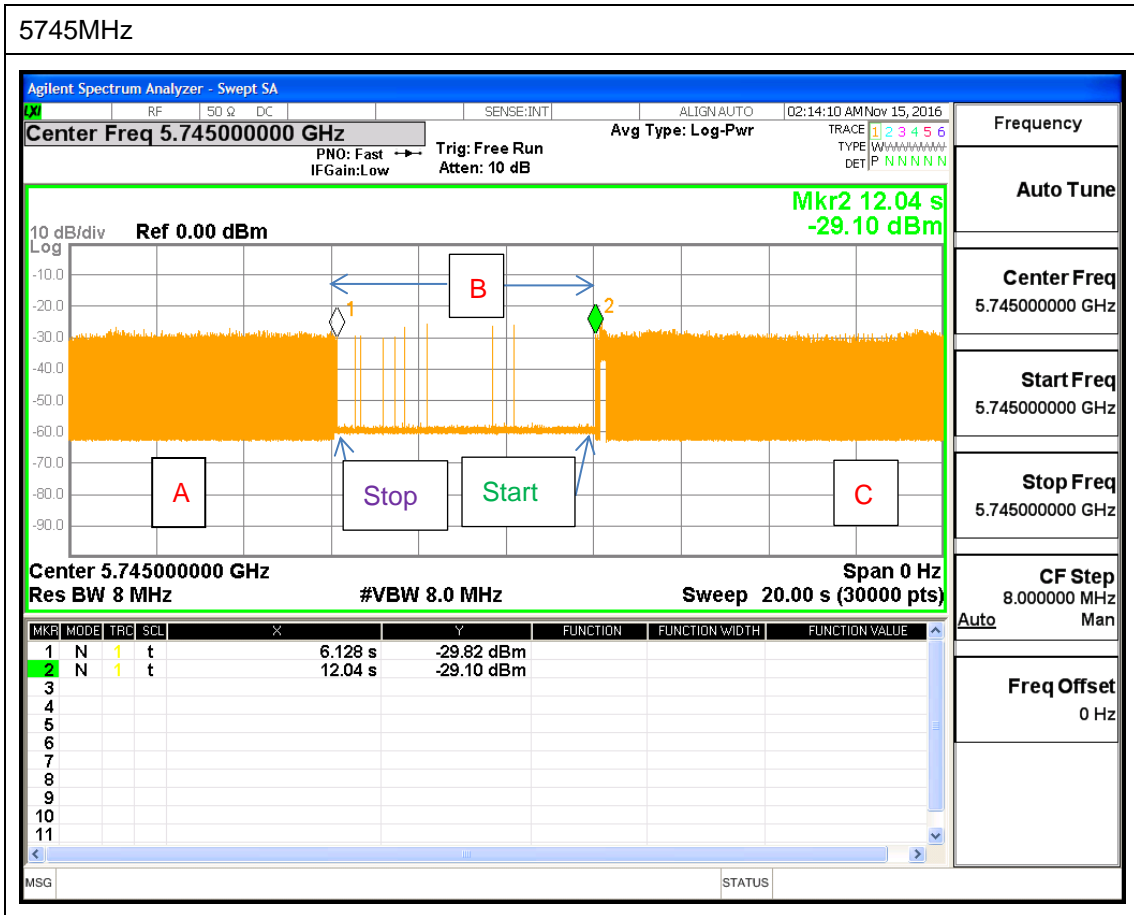

Note : The control / signalling information during the period B is precluded.



3.8 Antenna Requirements

3.8.1 Standard Applicable

If transmitting antenna directional gain is greater than 6 dBi, both the peak transmit power and the peak power spectral density shall be reduced by the amount in dB that the directional gain of the antenna exceeds 6 dBi.

3.8.2 Antenna Anti-Replacement Construction

An embedded-in antenna design is used.

3.8.3 Antenna Gain

CDD modes

FCC KDB 662911 D01 Multiple Transmitter Output v02r01

For CDD transmissions, directional gain is calculated as

Directional gain = $G_{ANT} + \text{Array Gain}$, where Array Gain is as follows.

For power spectral density (PSD) measurements on all devices,

Array Gain = $10 \log(N_{ANT}/N_{SS}=1)$ dB.

For power measurements on IEEE 802.11 devices,

Array Gain = 0 dB (i.e., no array gain) for $N_{ANT} \leq 4$.

Directional gain may be calculated by using the formulas applicable to equal gain antennas with G_{ANT} set equal to the gain of the antenna having the highest gain;

The EUT supports CDD mode.

For power, the directional gain G_{ANT} is set equal to the antenna having the highest gain, i.e., F)2)f)i).

For PSD, the directional gain calculation is following F)2)f)ii) of KDB 662911 D01 v02r01.

The power and PSD limit should be modified if the directional gain of EUT is over 6 dBi,

The directional gain "DG" is calculated as following table.

			DG	DG	Power	PSD
			for	for	Limit	Limit
	Ant 1	Ant 2	Power	PSD	Reduction	Reduction
	(dBi)	(dBi)	(dBi)	(dBi)	(dB)	(dB)
Band IV	3.43	4.14	4.14	6.80	0.00	0.80

Power limit reduction = Composite gain – 6dBi, (min = 0)

PSD limit reduction = Composite gain + PSD Array gain – 6dBi, (min = 0)



4 List of Measuring Equipment

Instrument	Manufacturer	Model No.	Serial No.	Characteristics	Calibration Date	Test Date	Due Date	Remark
AC Power Source	AC POWER	AFC-500W	F104070011	50Hz~60Hz	Dec. 01, 2016	Jul. 05, 2017 ~ Sep. 06, 2017	Nov. 30, 2017	Conducted (TH05-HY)
Power Meter	Anritsu	ML2495A	0932001	N/A	Sep. 29, 2016	Jul. 05, 2017 ~ Sep. 06, 2017	Sep. 28, 2017	Conducted (TH05-HY)
Power Sensor	Anritsu	MA2411B	0846202	300MHz~40GHz	Sep. 29, 2016	Jul. 05, 2017 ~ Sep. 06, 2017	Sep. 28, 2017	Conducted (TH05-HY)
Spectrum Analyzer	Rohde & Schwarz	FSP40	100057	9kHz-40GHz	Nov. 25, 2016	Jul. 05, 2017 ~ Sep. 06, 2017	Nov. 24, 2017	Conducted (TH05-HY)
Temperature Chamber	ESPEC	SH-641	92013720	-40°C ~90°C	Sep. 01, 2016	Jul. 05, 2017 ~ Sep. 06, 2017	Aug. 31, 2017	Conducted (TH05-HY)
Temperature Chamber	ESPEC	SH-641	92013720	-40°C ~90°C	Aug. 28, 2017	Aug. 27, 2017 ~ Sep. 06, 2017	Aug. 27, 2018	Conducted (TH05-HY)
AC Power Source	ChainTek	APC-1000W	N/A	N/A	N/A	Sep. 07, 2017	N/A	Conduction (CO05-HY)
LISN	Rohde & Schwarz	ENV216	100080	9kHz~30MHz	Nov. 29, 2016	Sep. 07, 2017	Nov. 28, 2017	Conduction (CO05-HY)
EMI Test Receiver	Rohde & Schwarz	ESU26	100472	20Hz~26.5GHz	Dec. 29, 2016	Sep. 07, 2017	Dec. 28, 2017	Conduction (CO05-HY)
Spectrum Analyzer	Keysight	N9010A	MY54200486	10Hz ~ 44GHz	Oct. 12, 2016	Jul. 14, 2017~ Jul. 25, 2017	Oct. 11, 2017	Radiation (03CH11-HY)
EMI Test Receiver	Agilent	N9038A(MXE)	MY53290053	20Hz to 26.5GHz	Jan. 12, 2017	Jul. 14, 2017~ Jul. 25, 2017	Jan. 11, 2018	Radiation (03CH11-HY)
Loop Antenna	Rohde & Schwarz	HFH2-Z2	100488	9 kHz~30 MHz	Oct. 20, 2016	Jul. 14, 2017~ Jul. 25, 2017	Oct. 19, 2018	Radiation (03CH11-HY)
Bilog Antenna	TESEQ	CBL 6111D&N-6-06	35414&AT-N 0602	30MHz~1GHz	Oct. 15, 2016	Jul. 14, 2017~ Jul. 25, 2017	Oct. 14, 2017	Radiation (03CH11-HY)
Horn Antenna	SCHWARZBECK	BBHA 9120 D	9120D-1326	1GHz ~ 18GHz	Oct. 07, 2016	Jul. 14, 2017~ Jul. 25, 2017	Oct. 06, 2017	Radiation (03CH11-HY)
SHF-EHF Horn Antenna	SCHWARZBECK	BBHA 9170	BBHA9170584	18GHz- 40GHz	Nov. 08, 2016	Jul. 14, 2017~ Jul. 25, 2017	Nov. 07, 2017	Radiation (03CH11-HY)
Amplifier	SONOMA	310N	187312	9kHz~1GHz	Nov. 10, 2016	Jul. 14, 2017~ Jul. 25, 2017	Nov. 09, 2017	Radiation (03CH11-HY)
Preamplifier	Keysight	83017A	MY53270080	1GHz~26.5GHz	Nov. 10, 2016	Jul. 14, 2017~ Jul. 25, 2017	Nov. 09, 2017	Radiation (03CH11-HY)
Preamplifier	MITEQ	AMF-7D-0010 1800-30-10P	1902247	1GHz~18GHz	Jun. 23, 2017	Jul. 14, 2017~ Jul. 25, 2017	Jun. 22, 2018	Radiation (03CH11-HY)
Preamplifier	MITEQ	TTA1840-35-HG	1887435	18GHz~40GHz	Oct. 13, 2016	Jul. 14, 2017~ Jul. 25, 2017	Oct. 12, 2017	Radiation (03CH11-HY)
Antenna Mast	EMEC	AM-BS-4500-B	N/A	1~4m	N/A	Jul. 14, 2017~ Jul. 25, 2017	N/A	Radiation (03CH11-HY)
Turn Table	EMEC	TT 2000	N/A	0~360 Degree	N/A	Jul. 14, 2017~ Jul. 25, 2017	N/A	Radiation (03CH11-HY)



5 Uncertainty of Evaluation

Uncertainty of Conducted Emission Measurement (150kHz ~ 30MHz)

Measuring Uncertainty for a Level of Confidence of 95% ($U = 2Uc(y)$)	2.70
---	------

Uncertainty of Radiated Emission Measurement (30 MHz ~ 1000 MHz)

Measuring Uncertainty for a Level of Confidence of 95% ($U = 2Uc(y)$)	5.20
---	------

Uncertainty of Radiated Emission Measurement (1000 MHz ~ 18000 MHz)

Measuring Uncertainty for a Level of Confidence of 95% ($U = 2Uc(y)$)	5.50
---	------

Uncertainty of Radiated Emission Measurement (18000 MHz ~ 40000 MHz)

Measuring Uncertainty for a Level of Confidence of 95% ($U = 2Uc(y)$)	5.20
---	------

Appendix A. Test Result of Conducted Test Items

Test Engineer:	Tommy Lee/Derek Hsu / Aking chang	Temperature:	21~25	°C
Test Date:	2017/7/5~2017/09/6	Relative Humidity:	51~54	%

TEST RESULTS DATA
6dB and 26dB EBW and 99% OBW

Band IV													
Mod.	Data Rate	NTX	CH.	Freq. (MHz)	99% Bandwidth (MHz)		26dB Bandwidth (MHz)		6 dB Bandwidth (MHz)		6 dB Bandwidth Min. Limit (MHz)		Pass/Fail
					Ant 1	Ant 2	Ant 1	Ant 2	Ant 1	Ant 2	Ant 1	Ant 2	
11a	6Mbps	2	149	5745	34.30	36.60	50.40	66.72	16.32	16.32	0.5		Pass
11a	6Mbps	2	157	5785	34.05	35.35	59.68	62.08	16.32	16.32	0.5		Pass
11a	6Mbps	2	165	5825	33.40	34.50	50.72	56.64	16.32	16.32	0.5		Pass
HT20	MCS0	2	149	5745	35.30	38.05	61.60	69.92	17.56	17.56	0.5		Pass
HT20	MCS0	2	157	5785	36.05	37.50	59.04	67.20	17.56	17.60	0.5		Pass
HT20	MCS0	2	165	5825	35.40	36.70	53.44	64.96	17.56	17.56	0.5		Pass
HT40	MCS0	2	151	5755	60.70	60.60	102.08	101.44	36.32	36.32	0.5		Pass
HT40	MCS0	2	159	5795	68.40	66.80	103.68	103.68	36.40	36.40	0.5		Pass
VHT80	MCS0	2	155	5775	75.84	75.96	100.80	100.80	75.84	75.68	0.5		Pass

TEST RESULTS DATA
Average Power Table

Band IV														
Mod.	Data Rate	NTX	CH.	Freq. (MHz)	Duty Factor (dB)		Average Conducted Power (dBm)			FCC Conducted Power Limit (dBm)		DG (dBi)		Pass/Fail
					Ant 1	Ant 2	Ant 1	Ant 2	SUM	Ant 1	Ant 2	Ant 1	Ant 2	
11a	6Mbps	1	149	5745	0.04	0.04	25.78	25.94		30.00	30.00	3.43	4.14	Pass
11a	6Mbps	1	157	5785	0.04	0.04	25.67	25.66		30.00	30.00	3.43	4.14	Pass
11a	6Mbps	1	165	5825	0.04	0.04	25.47	25.77		30.00	30.00	3.43	4.14	Pass
HT20	MCS0	1	149	5745	0.07	0.07	25.77	25.73		30.00	30.00	3.43	4.14	Pass
HT20	MCS0	1	157	5785	0.07	0.07	25.67	25.65		30.00	30.00	3.43	4.14	Pass
HT20	MCS0	1	165	5825	0.07	0.07	25.47	25.77		30.00	30.00	3.43	4.14	Pass
HT40	MCS0	1	151	5755	0.08	0.08	24.23	24.58		30.00	30.00	3.43	4.14	Pass
HT40	MCS0	1	159	5795	0.08	0.08	24.81	24.69		30.00	30.00	3.43	4.14	Pass
VHT20	MCS0	1	149	5745	0.04	0.04	25.46	25.66		30.00	30.00	3.43	4.14	Pass
VHT20	MCS0	1	157	5785	0.04	0.04	25.54	25.64		30.00	30.00	3.43	4.14	Pass
VHT20	MCS0	1	165	5825	0.04	0.04	25.46	25.74		30.00	30.00	3.43	4.14	Pass
VHT40	MCS0	1	151	5755	0.08	0.08	24.16	24.48		30.00	30.00	3.43	4.14	Pass
VHT40	MCS0	1	159	5795	0.08	0.08	24.36	24.46		30.00	30.00	3.43	4.14	Pass
VHT80	MCS0	1	155	5775	0.08	0.08	21.52	21.53		30.00	30.00	3.43	4.14	Pass
11a	6Mbps	2	149	5745	0.04	0.05	25.83	26.10	28.98	30.00		4.14		Pass
11a	6Mbps	2	157	5785	0.04	0.05	25.99	25.85	28.93	30.00		4.14		Pass
11a	6Mbps	2	165	5825	0.04	0.05	25.69	26.01	28.87	30.00		4.14		Pass
HT20	MCS0	2	149	5745	0.07	0.04	25.80	26.13	28.98	30.00		4.14		Pass
HT20	MCS0	2	157	5785	0.07	0.04	25.97	25.94	28.97	30.00		4.14		Pass
HT20	MCS0	2	165	5825	0.07	0.04	25.80	26.03	28.93	30.00		4.14		Pass
HT40	MCS0	2	151	5755	0.08	0.08	24.39	24.84	27.63	30.00		4.14		Pass
HT40	MCS0	2	159	5795	0.08	0.08	24.88	25.18	28.04	30.00		4.14		Pass
VHT20	MCS0	2	149	5745	0.04	0.04	25.73	26.09	28.93	30.00		4.14		Pass
VHT20	MCS0	2	157	5785	0.04	0.04	25.94	25.89	28.93	30.00		4.14		Pass
VHT20	MCS0	2	165	5825	0.04	0.04	25.67	25.82	28.76	30.00		4.14		Pass
VHT40	MCS0	2	151	5755	0.08	0.08	24.26	24.76	27.52	30.00		4.14		Pass
VHT40	MCS0	2	159	5795	0.08	0.08	24.43	24.63	27.54	30.00		4.14		Pass
VHT80	MCS0	2	155	5775	0.08	0.08	21.53	21.63	24.59	30.00		4.14		Pass

TEST RESULTS DATA
Power Spectral Density

Band IV																
Mod.	Data Rate	NTX	CH.	Freq. (MHz)	Duty Factor (dB)		10log (500kHz /RBW) Factor (dB)		Average Power Density (dBm/500kHz)			Average PSD Limit (dBm/500kHz)		DG (dBi)		Pass /Fail
					Ant 1	Ant 2	Ant 1	Ant 2	Ant 1	Ant 2	SUM	Ant 1	Ant 2	Ant 1	Ant 2	
11a	6Mbps	2	149	5745	0.04	0.05	2.22				14.00	29.20		6.80		Pass
11a	6Mbps	2	157	5785	0.04	0.05	2.22				13.95	29.20		6.80		Pass
11a	6Mbps	2	165	5825	0.04	0.05	2.22				13.94	29.20		6.80		Pass
HT20	MCS0	2	149	5745	0.07	0.04	2.22				13.77	29.20		6.80		Pass
HT20	MCS0	2	157	5785	0.07	0.04	2.22				13.52	29.20		6.80		Pass
HT20	MCS0	2	165	5825	0.07	0.04	2.22				13.69	29.20		6.80		Pass
HT40	MCS0	2	151	5755	0.08	0.08	2.22				9.90	29.20		6.80		Pass
HT40	MCS0	2	159	5795	0.08	0.08	2.22				9.88	29.20		6.80		Pass
VHT20	MCS0	2	149	5745	0.04	0.04	2.22				13.53	29.20		6.80		Pass
VHT20	MCS0	2	157	5785	0.04	0.04	2.22				13.24	29.20		6.80		Pass
VHT20	MCS0	2	165	5825	0.04	0.04	2.22				13.41	29.20		6.80		Pass
VHT40	MCS0	2	151	5755	0.08	0.08	2.22				9.78	29.20		6.80		Pass
VHT40	MCS0	2	159	5795	0.08	0.08	2.22				9.57	29.20		6.80		Pass
VHT80	MCS0	2	155	5775	0.08	0.08	2.22				4.17	29.20		6.80		Pass

TEST RESULTS DATA
Frequency Stability

Band IV										
Mod.	Data Rate	NTX	CH.	Freq. (MHz)	Center Frequency (MHz)	Frequency Deviation (MHz)	Frequency Stability (ppm)	Temperature (°C)	Voltage (V)	Note
11a	6Mbps	1	149	5745	5745.050	0.050	8.70	45	120	0 min
11a	6Mbps	1	149	5745	5745.050	0.050	8.70	-40	120	0 min
11a	6Mbps	1	149	5745	5745.100	0.100	17.41	20	132	0 min
11a	6Mbps	1	149	5745	5745.050	0.050	8.70	20	108	0 min
11a	6Mbps	1	149	5745	5745.100	0.100	17.41	20	120	0 min
11a	6Mbps	1	149	5745	5745.050	0.050	8.70	45	120	2 min
11a	6Mbps	1	149	5745	5745.000	0.000	0.00	-40	120	2 min
11a	6Mbps	1	149	5745	5745.100	0.100	17.41	20	132	2 min
11a	6Mbps	1	149	5745	5745.075	0.075	13.05	20	108	2 min
11a	6Mbps	1	149	5745	5745.100	0.100	17.41	20	120	2 min
11a	6Mbps	1	149	5745	5745.050	0.050	8.70	45	120	5 min
11a	6Mbps	1	149	5745	5745.000	0.000	0.00	-40	120	5 min
11a	6Mbps	1	149	5745	5745.100	0.100	17.41	20	132	5 min
11a	6Mbps	1	149	5745	5745.100	0.100	17.41	20	108	5 min
11a	6Mbps	1	149	5745	5745.100	0.100	17.41	20	120	5 min
11a	6Mbps	1	149	5745	5745.050	0.050	8.70	45	120	10 min
11a	6Mbps	1	149	5745	5745.050	0.050	8.70	-40	120	10 min
11a	6Mbps	1	149	5745	5745.100	0.100	17.41	20	132	10 min
11a	6Mbps	1	149	5745	5745.075	0.075	13.05	20	108	10 min
11a	6Mbps	1	149	5745	5745.150	0.150	26.11	20	120	10 min



Appendix B. AC Conducted Emission Test Results

Test Engineer :	Kai-Chun Chu	Temperature :	26~27°C
		Relative Humidity :	54~55%

EUT Information

Report NO : 6N0107-01
 Test Mode : Mode 1
 Test Voltage : 120Vac/60Hz
 Phase : Line

ENV216 Auto Test FCC Power Bar - L

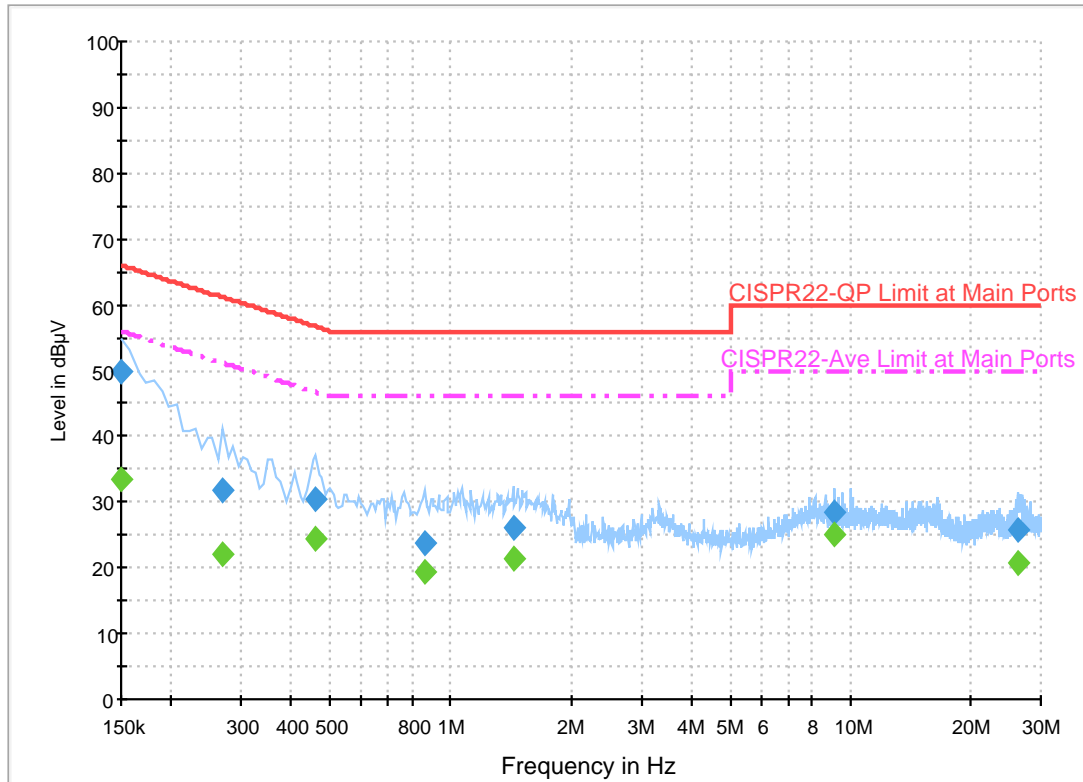

Final Result 1

Frequency (MHz)	QuasiPeak (dBµV)	Filter	Line	Corr. (dB)	Margin (dB)	Limit (dBµV)
0.150000	49.9	Off	L1	19.6	16.1	66.0
0.270000	31.8	Off	L1	19.6	29.3	61.1
0.462000	30.6	Off	L1	19.6	26.1	56.7
0.862000	23.8	Off	L1	19.6	32.2	56.0
1.438000	26.1	Off	L1	19.6	29.9	56.0
9.110000	28.3	Off	L1	20.0	31.7	60.0
26.198000	25.6	Off	L1	20.8	34.4	60.0

Final Result 2

Frequency (MHz)	Average (dBµV)	Filter	Line	Corr. (dB)	Margin (dB)	Limit (dBµV)
0.150000	33.4	Off	L1	19.6	22.6	56.0
0.270000	22.1	Off	L1	19.6	29.0	51.1
0.462000	24.4	Off	L1	19.6	22.3	46.7
0.862000	19.4	Off	L1	19.6	26.6	46.0
1.438000	21.3	Off	L1	19.6	24.7	46.0
9.110000	25.0	Off	L1	20.0	25.0	50.0
26.198000	20.8	Off	L1	20.8	29.2	50.0

EUT Information

Report NO : 6N0107-01
 Test Mode : Mode 1
 Test Voltage : 120Vac/60Hz
 Phase : Neutral

ENV216 Auto Test FCC Power Bar - N

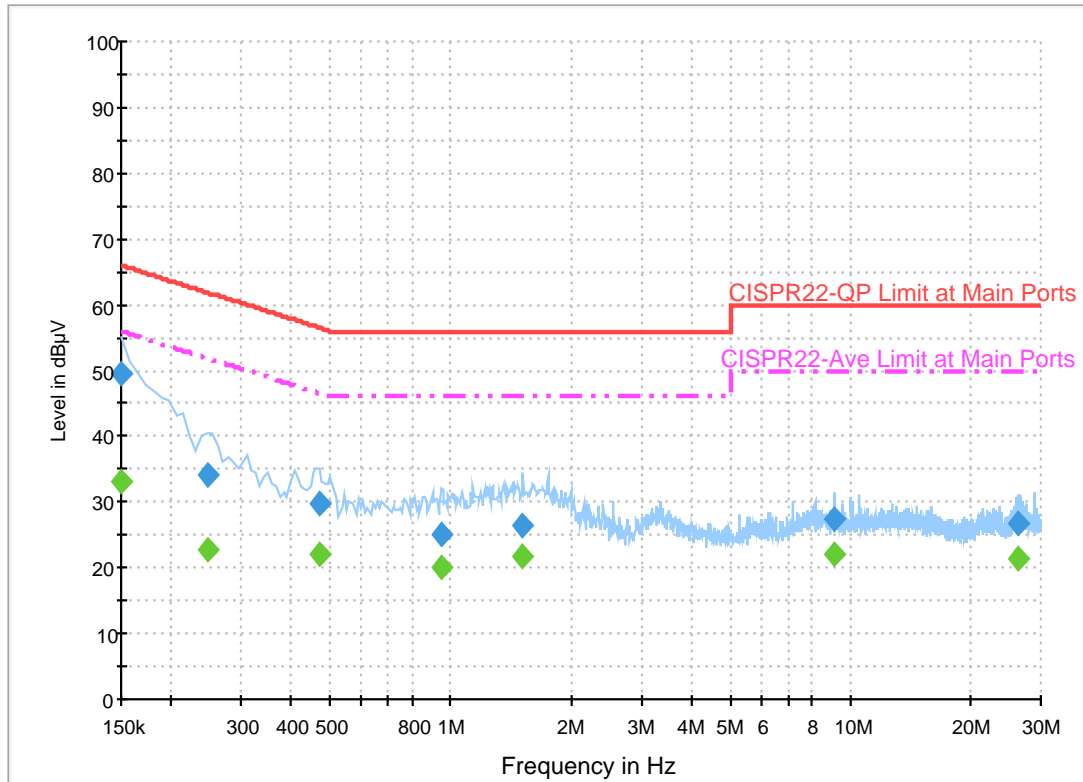

Final Result 1

Frequency (MHz)	QuasiPeak (dBµV)	Filter	Line	Corr. (dB)	Margin (dB)	Limit (dBµV)
0.150000	49.6	Off	N	19.5	16.4	66.0
0.246000	34.1	Off	N	19.5	27.8	61.9
0.470000	29.9	Off	N	19.5	26.6	56.5
0.950000	25.2	Off	N	19.6	30.8	56.0
1.518000	26.4	Off	N	19.6	29.6	56.0
9.142000	27.5	Off	N	20.0	32.5	60.0
26.398000	26.7	Off	N	21.0	33.3	60.0

Final Result 2

Frequency (MHz)	Average (dBµV)	Filter	Line	Corr. (dB)	Margin (dB)	Limit (dBµV)
0.150000	33.1	Off	N	19.5	22.9	56.0
0.246000	22.8	Off	N	19.5	29.1	51.9
0.470000	22.1	Off	N	19.5	24.4	46.5
0.950000	20.0	Off	N	19.6	26.0	46.0
1.518000	21.6	Off	N	19.6	24.4	46.0
9.142000	22.1	Off	N	20.0	27.9	50.0
26.398000	21.5	Off	N	21.0	28.5	50.0



Appendix C. Radiated Spurious Emission

Test Engineer :	J.C. Liang, Jacky Huang, Ken Wu	Temperature :	20~24°C
		Relative Humidity :	50~54%

Band 4 - 5725~5850MHz

WIFI 802.11a (Band Edge @ 3m)

WIFI Ant. 1+2	Note	Frequency (MHz)	Level (dBμV/m)	Over Limit (dB)	Limit Line (dBμV/m)	Read Level (dBμV)	Antenna Factor (dB/m)	Cable Loss (dB)	Preamp Factor (dB)	Ant Pos (cm)	Table Pos (deg)	Peak Avg. (P/A)	Pol. (H/V)
802.11a CH 149 5745MHz		5649.8	64.27	-3.93	68.2	54.99	32.77	9.61	33.1	100	297	P	H
		5699	82.71	-21.75	104.46	73.22	32.86	9.75	33.12	100	297	P	H
		5719.2	98.02	-12.56	110.58	88.4	32.94	9.81	33.13	100	297	P	H
		5725	101.82	-20.38	122.2	92.2	32.94	9.81	33.13	100	297	P	H
	*	5745	123.98	-	-	114.27	32.98	9.88	33.15	100	297	P	H
	*	5745	116.14	-	-	106.43	32.98	9.88	33.15	100	297	A	H
		5630	59.52	-8.68	68.2	50.32	32.69	9.61	33.1	233	282	P	V
		5697.8	76.17	-27.41	103.58	66.68	32.86	9.75	33.12	233	282	P	V
		5719.8	93.82	-16.92	110.74	84.2	32.94	9.81	33.13	233	282	P	V
		5724.8	98.84	-22.9	121.74	89.22	32.94	9.81	33.13	233	282	P	V
	*	5745	123.48	-	-	113.77	32.98	9.88	33.15	233	282	P	V
	*	5745	115.17	-	-	105.46	32.98	9.88	33.15	233	282	A	V



WIFI Ant. 1+2	Note	Frequency (MHz)	Level (dBμV/m)	Over Limit (dB)	Limit Line (dBμV/m)	Read Level (dBμV)	Antenna Factor (dB/m)	Cable Loss (dB)	Preamp Factor (dB)	Ant Pos (cm)	Table Pos (deg)	Peak Avg. (P/A)	Pol. (H/V)
802.11a CH 157 5785MHz		5643.6	63.01	-5.19	68.2	53.77	32.73	9.61	33.1	100	296	P	H
		5685.6	65.74	-28.84	94.58	56.25	32.86	9.75	33.12	100	296	P	H
		5717.4	69.85	-40.22	110.07	60.27	32.9	9.81	33.13	100	296	P	H
		5724.4	75.22	-45.61	120.83	65.6	32.94	9.81	33.13	100	296	P	H
	*	5785	124.79	-	-	114.89	33.06	10.01	33.17	100	296	P	H
	*	5785	115.5	-	-	105.6	33.06	10.01	33.17	100	296	A	H
		5850.4	69.22	-52.07	121.29	59.16	33.23	10.02	33.19	100	296	P	H
		5863.6	66.61	-41.78	108.39	56.53	33.27	10.02	33.21	100	296	P	H
		5875.8	64.23	-40.38	104.61	54.11	33.31	10.02	33.21	100	296	P	H
		5928	58.91	-9.29	68.2	48.69	33.43	10.02	33.23	100	296	P	H
		5613.6	59.51	-8.69	68.2	50.39	32.65	9.55	33.08	228	279	P	V
		5698	60.95	-42.78	103.73	51.46	32.86	9.75	33.12	228	279	P	V
		5715	66.44	-42.96	109.4	56.86	32.9	9.81	33.13	228	279	P	V
		5723.4	69.47	-49.08	118.55	59.85	32.94	9.81	33.13	228	279	P	V
	*	5785	121.56	-	-	111.66	33.06	10.01	33.17	228	279	P	V
	*	5785	113.37	-	-	103.47	33.06	10.01	33.17	228	279	A	V
		5850	67.9	-54.3	122.2	57.84	33.23	10.02	33.19	228	279	P	V
		5855.8	66.34	-44.24	110.58	56.24	33.27	10.02	33.19	228	279	P	V
		5883.6	58.22	-40.59	98.81	48.11	33.31	10.02	33.22	228	279	P	V
	5926.8	57.1	-11.1	68.2	46.88	33.43	10.02	33.23	228	279	P	V	



WiFi Ant. 1+2	Note	Frequency (MHz)	Level (dBµV/m)	Over Limit (dB)	Limit Line (dBµV/m)	Read Level (dBµV)	Antenna Factor (dB/m)	Cable Loss (dB)	Preamp Factor (dB)	Ant Pos (cm)	Table Pos (deg)	Peak Avg. (P/A)	Pol. (H/V)
802.11a CH 165 5825MHz	*	5825	124.47	-	-	114.44	33.19	10.02	33.18	100	244	P	H
	*	5825	115.52	-	-	105.49	33.19	10.02	33.18	100	244	A	H
		5853.8	95.39	-18.15	113.54	85.29	33.27	10.02	33.19	100	244	P	H
		5859.2	93.21	-16.41	109.62	83.13	33.27	10.02	33.21	100	244	P	H
		5876.8	74.64	-29.22	103.86	64.52	33.31	10.02	33.21	100	244	P	H
		5931.4	61.73	-6.47	68.2	51.51	33.43	10.02	33.23	100	244	P	H
	*	5825	122.28	-	-	112.25	33.19	10.02	33.18	243	279	P	V
	*	5825	113.47	-	-	103.44	33.19	10.02	33.18	243	279	A	V
		5853.4	88.73	-25.72	114.45	78.67	33.23	10.02	33.19	243	279	P	V
		5858.6	86.02	-23.77	109.79	75.94	33.27	10.02	33.21	243	279	P	V
		5875.6	72.51	-32.24	104.75	62.39	33.31	10.02	33.21	243	279	P	V
		5926	58.02	-10.18	68.2	47.8	33.43	10.02	33.23	243	279	P	V
	Remark	<ol style="list-style-type: none"> No other spurious found. All results are PASS against Peak and Average limit line. 											



Band 4 5725~5850MHz
WIFI 802.11a (Harmonic @ 3m)

WIFI Ant. 1+2	Note	Frequency (MHz)	Level (dBμV/m)	Over Limit (dB)	Limit Line (dBμV/m)	Read Level (dBμV)	Antenna Factor (dB/m)	Cable Loss (dB)	Preamp Factor (dB)	Ant Pos (cm)	Table Pos (deg)	Peak Avg. (P/A)	Pol. (H/V)
802.11a CH 149 5745MHz		5320	59.29	-8.91	68.2	50.93	32.22	9.17	33.03	100	297	P	H
		5536	60.95	-7.25	68.2	52.11	32.48	9.41	33.05	100	297	P	H
		5956	62.25	-5.95	68.2	51.95	33.52	10.02	33.24	100	297	P	H
		6178	58.12	-10.08	68.2	47.3	33.89	10.25	33.32	100	297	P	H
		11490	57.11	-16.89	74	65.9	38.52	15.44	63.03	222	276	P	H
		11490	48.62	-5.38	54	57.41	38.52	15.44	63.03	222	276	A	H
		17235	60.33	-7.87	68.2	61.04	40.76	19.24	61.07	100	0	P	H
		5320	59.21	-8.99	68.2	50.85	32.22	9.17	33.03	233	282	P	V
		5530	58.76	-9.44	68.2	49.96	32.44	9.41	33.05	233	282	P	V
		5968	59.12	-9.08	68.2	48.83	33.52	10.03	33.26	233	282	P	V
		6166	58.87	-9.33	68.2	48.1	33.87	10.22	33.32	233	282	P	V
		11490	55.92	-18.08	74	64.99	38.52	15.44	63.03	104	178	P	V
		11490	47.75	-6.25	54	56.82	38.52	15.44	63.03	104	178	A	V
		17235	59.84	-8.36	68.2	60.55	40.76	19.24	61.07	100	0	P	V
802.11a CH 157 5785MHz		5302	58.77	-9.43	68.2	50.44	32.2	9.16	33.03	100	296	P	H
		6274	56.94	-11.26	68.2	45.95	34.03	10.31	33.35	100	296	P	H
		11570	56.41	-17.59	74	65	38.56	15.49	62.92	294	280	P	H
		11570	46.88	-7.12	54	55.47	38.56	15.49	62.92	294	280	A	H
		17355	59.75	-8.45	68.2	59.63	40.69	19.31	60.25	100	0	P	H
		5296	55.99	-12.21	68.2	47.66	32.2	9.16	33.03	228	279	P	V
		6262	55.36	-12.84	68.2	44.37	34.03	10.31	33.35	228	279	P	V
		11570	56.56	-17.44	74	65.43	38.56	15.49	62.92	100	178	P	V
		11570	45.82	-8.18	54	54.69	38.56	15.49	62.92	100	178	A	V
	17355	58.31	-9.89	68.2	58.19	40.69	19.31	60.25	100	0	P	V	



802.11a CH 165 5825MHz		5344	56.61	-11.59	68.2	48.2	32.25	9.19	33.03	100	244	P	H
		6064	59.1	-9.1	68.2	48.59	33.71	10.09	33.29	100	244	P	H
		6304	55.6	-12.6	68.2	44.55	34.08	10.33	33.36	100	244	P	H
		11650	55.86	-18.14	74	64.24	38.61	15.56	62.83	100	312	A	H
		11650	46.74	-7.26	54	55.12	38.61	15.56	62.83	100	312	P	H
		17475	60.94	-7.26	68.2	60	40.62	19.37	59.43	100	0	P	H
		5344	54.77	-13.43	68.2	46.36	32.25	9.19	33.03	243	279	P	V
		6304	55.05	-13.15	68.2	44	34.08	10.33	33.36	243	279	P	V
		11650	56.12	-17.88	74	64.78	38.61	15.56	62.83	100	180	P	V
		11650	47.27	-6.73	54	55.93	38.61	15.56	62.83	100	180	A	V
		17475	60.56	-7.64	68.2	59.62	40.62	19.37	59.43	100	0	P	V
Remark	1. No other spurious found. 2. All results are PASS against Peak and Average limit line.												



Band 4 5725~5850MHz
WIFI 802.11n HT20 (Band Edge @ 3m)

Table with 14 columns: WIFI Ant. 1+2, Note, Frequency (MHz), Level (dBµV/m), Over Limit (dB), Limit Line (dBµV/m), Read Level (dBµV), Antenna Factor (dB/m), Cable Loss (dB), Preamp Factor (dB), Ant Pos (cm), Table Pos (deg), Peak Avg. (P/A), Pol. (H/V). Rows include test data for frequencies from 5643 to 5745 MHz.



WIFI Ant. 1+2	Note	Frequency (MHz)	Level (dBμV/m)	Over Limit (dB)	Limit Line (dBμV/m)	Read Level (dBμV)	Antenna Factor (dB/m)	Cable Loss (dB)	Preamp Factor (dB)	Ant Pos (cm)	Table Pos (deg)	Peak Avg. (P/A)	Pol. (H/V)
802.11n HT20 CH 157 5785MHz		5630.8	61.26	-6.94	68.2	52.06	32.69	9.61	33.1	100	242	P	H
		5699.6	65.51	-39.4	104.91	56.02	32.86	9.75	33.12	100	242	P	H
		5716.8	73.65	-36.26	109.91	64.07	32.9	9.81	33.13	100	242	P	H
		5722.4	76.55	-39.72	116.27	66.93	32.94	9.81	33.13	100	242	P	H
	*	5785	125.16	-	-	115.26	33.06	10.01	33.17	100	242	P	H
	*	5785	116.98	-	-	107.08	33.06	10.01	33.17	100	242	A	H
		5853.2	73.9	-41	114.9	63.84	33.23	10.02	33.19	100	242	P	H
		5855.4	73.13	-37.56	110.69	63.03	33.27	10.02	33.19	100	242	P	H
		5882.8	66.63	-32.78	99.41	56.51	33.31	10.02	33.21	100	242	P	H
		5937	62.06	-6.14	68.2	51.85	33.43	10.02	33.24	100	242	P	H
		5639.4	59.06	-9.14	68.2	49.82	32.73	9.61	33.1	181	204	P	V
		5697.8	62.09	-41.49	103.58	52.6	32.86	9.75	33.12	181	204	P	V
		5718.4	68.66	-41.69	110.35	59.04	32.94	9.81	33.13	181	204	P	V
		5723	70.95	-46.69	117.64	61.33	32.94	9.81	33.13	181	204	P	V
	*	5785	124.18	-	-	114.28	33.06	10.01	33.17	181	204	P	V
	*	5785	115.42	-	-	105.52	33.06	10.01	33.17	181	204	A	V
		5854.4	70.47	-41.7	112.17	60.37	33.27	10.02	33.19	181	204	P	V
		5856.2	66.85	-43.61	110.46	56.75	33.27	10.02	33.19	181	204	P	V
		5877	64.05	-39.66	103.71	53.93	33.31	10.02	33.21	181	204	P	V
		5926.2	56.53	-11.67	68.2	46.31	33.43	10.02	33.23	181	204	P	V



WIFI Ant. 1+2	Note	Frequency (MHz)	Level (dBμV/m)	Over Limit (dB)	Limit Line (dBμV/m)	Read Level (dBμV)	Antenna Factor (dB/m)	Cable Loss (dB)	Preamp Factor (dB)	Ant Pos (cm)	Table Pos (deg)	Peak Avg. (P/A)	Pol. (H/V)
802.11n HT20 CH 165 5825MHz	*	5825	126.37	-	-	116.34	33.19	10.02	33.18	100	245	P	H
	*	5825	117.45	-	-	107.42	33.19	10.02	33.18	100	245	A	H
		5850	98.68	-23.52	122.2	88.62	33.23	10.02	33.19	100	245	P	H
		5858.8	95.71	-14.02	109.73	85.63	33.27	10.02	33.21	100	245	P	H
		5880.4	81.45	-19.74	101.19	71.33	33.31	10.02	33.21	100	245	P	H
		5933	64.63	-3.57	68.2	54.41	33.43	10.02	33.23	100	245	P	H
	*	5825	123.04	-	-	113.01	33.19	10.02	33.18	246	211	P	V
	*	5825	114.77	-	-	104.74	33.19	10.02	33.18	246	211	A	V
		5850	97.15	-25.05	122.2	87.09	33.23	10.02	33.19	246	211	P	V
		5855	90.44	-20.36	110.8	80.34	33.27	10.02	33.19	246	211	P	V
		5879.6	75.98	-25.8	101.78	65.86	33.31	10.02	33.21	246	211	P	V
		5927	60.86	-7.34	68.2	50.64	33.43	10.02	33.23	246	211	P	V
Remark	1. No other spurious found. 2. All results are PASS against Peak and Average limit line.												



Band 4 5725~5850MHz
WIFI 802.11n HT20 (Harmonic @ 3m)

WIFI Ant. 1+2	Note	Frequency (MHz)	Level (dBμV/m)	Over Limit (dB)	Limit Line (dBμV/m)	Read Level (dBμV)	Antenna Factor (dB/m)	Cable Loss (dB)	Preamp Factor (dB)	Ant Pos (cm)	Table Pos (deg)	Peak Avg. (P/A)	Pol. (H/V)
802.11n HT20 CH 149 5745MHz		5326	60.56	-7.64	68.2	52.2	32.22	9.17	33.03	100	244	P	H
		5524	61.69	-6.51	68.2	52.87	32.44	9.41	33.03	100	244	P	H
		6172	59.35	-8.85	68.2	48.55	33.87	10.25	33.32	100	244	P	H
		6382	55.96	-12.24	68.2	44.75	34.21	10.38	33.38	100	244	P	H
		11490	56.78	-17.22	74	65.57	38.52	15.44	63.03	100	279	P	H
		11490	46.88	-7.12	54	55.67	38.52	15.44	63.03	100	279	A	H
		17235	59.37	-8.83	68.2	60.08	40.76	19.24	61.07	100	0	P	H
		5320	57.22	-10.98	68.2	48.86	32.22	9.17	33.03	204	212	P	V
		5530	60.08	-8.12	68.2	51.28	32.44	9.41	33.05	204	212	P	V
		5956	59.59	-8.61	68.2	49.29	33.52	10.02	33.24	204	212	P	V
		6166	57.37	-10.83	68.2	46.6	33.87	10.22	33.32	204	212	P	V
		11490	55.18	-18.82	74	64.25	38.52	15.44	63.03	100	277	P	V
		11490	46.13	-7.87	54	55.2	38.52	15.44	63.03	100	277	A	V
		17235	56.3	-11.9	68.2	57.01	40.76	19.24	61.07	100	0	P	V
802.11n HT20 CH 157 5785MHz		5302	56.23	-11.97	68.2	47.9	32.2	9.16	33.03	100	242	P	H
		6028	61.12	-7.08	68.2	50.69	33.65	10.06	33.28	100	242	P	H
		6268	56.39	-11.81	68.2	45.4	34.03	10.31	33.35	100	242	P	H
		11570	60.18	-13.82	74	68.77	38.56	15.49	62.92	226	296	P	H
		11570	51.03	-2.97	54	59.62	38.56	15.49	62.92	226	296	A	H
		17355	61	-7.2	68.2	60.88	40.69	19.31	60.25	100	0	P	H
		5308	53.29	-14.91	68.2	44.96	32.2	9.16	33.03	181	204	P	V
		5986	57.88	-10.32	68.2	47.56	33.56	10.03	33.27	181	204	P	V
		6022	57.38	-10.82	68.2	46.97	33.63	10.06	33.28	181	204	P	V
		6268	54.7	-13.5	68.2	43.71	34.03	10.31	33.35	181	204	P	V
		11570	56.43	-17.57	74	65.3	38.56	15.49	62.92	100	178	P	V
	11570	47.6	-6.4	54	56.47	38.56	15.49	62.92	100	178	A	V	
	17355	56.35	-11.85	68.2	56.23	40.69	19.31	60.25	100	0	P	V	



802.11n HT20 CH 165 5825MHz		5344	56.5	-11.7	68.2	48.09	32.25	9.19	33.03	100	245	P	H
		6058	59.96	-8.24	68.2	49.44	33.71	10.09	33.28	100	245	P	H
		6304	55.43	-12.77	68.2	44.38	34.08	10.33	33.36	100	245	P	H
		11650	58.43	-15.57	74	66.81	38.61	15.56	62.83	258	172	P	H
		11650	50.37	-3.63	54	58.75	38.61	15.56	62.83	258	172	A	H
		17475	60.93	-7.27	68.2	59.99	40.62	19.37	59.43	100	0	P	H
		5344	53.23	-14.97	68.2	44.82	32.25	9.19	33.03	246	211	P	V
		6058	56.97	-11.23	68.2	46.45	33.71	10.09	33.28	246	211	P	V
		6304	55.19	-13.01	68.2	44.14	34.08	10.33	33.36	246	211	P	V
		11650	53.73	-20.27	74	62.39	38.61	15.56	62.83	100	178	P	V
		11650	47.23	-6.77	54	55.89	38.61	15.56	62.83	100	178	A	V
	17475	58.56	-9.64	68.2	57.62	40.62	19.37	59.43	100	0	P	V	
Remark	1. No other spurious found. 2. All results are PASS against Peak and Average limit line.												



Band 4 5725~5850MHz
WIFI 802.11n HT40 (Band Edge @ 3m)

WIFI Ant. 1+2	Note	Frequency (MHz)	Level (dBμV/m)	Over Limit (dB)	Limit Line (dBμV/m)	Read Level (dBμV)	Antenna Factor (dB/m)	Cable Loss (dB)	Preamp Factor (dB)	Ant Pos (cm)	Table Pos (deg)	Peak Avg. (P/A)	Pol. (H/V)
802.11n HT40 CH 151 5755MHz		5643.6	65.73	-2.47	68.2	56.49	32.73	9.61	33.1	100	245	P	H
		5699.8	80.03	-25.02	105.05	70.54	32.86	9.75	33.12	100	245	P	H
		5719	96.65	-13.87	110.52	87.03	32.94	9.81	33.13	100	245	P	H
		5722.6	99.47	-17.26	116.73	89.85	32.94	9.81	33.13	100	245	P	H
	*	5755	119.78	-	-	110.03	33.02	9.88	33.15	100	245	P	H
	*	5755	111.31	-	-	101.56	33.02	9.88	33.15	100	245	A	H
		5852.4	71.71	-45.02	116.73	61.65	33.23	10.02	33.19	100	245	P	H
		5856.8	71.37	-38.93	110.3	61.27	33.27	10.02	33.19	100	245	P	H
		5877.2	66.56	-37.01	103.57	56.44	33.31	10.02	33.21	100	245	P	H
		5925.4	59.67	-8.53	68.2	49.45	33.43	10.02	33.23	100	245	P	H
		5646.4	64.59	-3.61	68.2	55.35	32.73	9.61	33.1	213	207	P	V
		5699.8	79.84	-25.21	105.05	70.35	32.86	9.75	33.12	213	207	P	V
		5718.6	94.86	-15.55	110.41	85.24	32.94	9.81	33.13	213	207	P	V
		5724	95.32	-24.6	119.92	85.7	32.94	9.81	33.13	213	207	P	V
	*	5755	119.42	-	-	109.67	33.02	9.88	33.15	213	207	P	V
	*	5755	110.8	-	-	101.05	33.02	9.88	33.15	213	207	A	V
		5854.2	67.77	-44.85	112.62	57.67	33.27	10.02	33.19	213	207	P	V
		5863.8	66.37	-41.96	108.33	56.29	33.27	10.02	33.21	213	207	P	V
		5881	62.5	-38.24	100.74	52.38	33.31	10.02	33.21	213	207	P	V
		5932.4	57.25	-10.95	68.2	47.03	33.43	10.02	33.23	213	207	P	V



WIFI Ant. 1+2	Note	Frequency (MHz)	Level (dBμV/m)	Over Limit (dB)	Limit Line (dBμV/m)	Read Level (dBμV)	Antenna Factor (dB/m)	Cable Loss (dB)	Preamp Factor (dB)	Ant Pos (cm)	Table Pos (deg)	Peak Avg. (P/A)	Pol. (H/V)
802.11n HT40 CH 159 5795MHz		5625.4	62.4	-5.8	68.2	53.24	32.69	9.55	33.08	100	245	P	H
		5697	69.3	-33.69	102.99	59.81	32.86	9.75	33.12	100	245	P	H
		5719.8	74.36	-36.38	110.74	64.74	32.94	9.81	33.13	100	245	P	H
		5722	76.9	-38.46	115.36	67.28	32.94	9.81	33.13	100	245	P	H
	*	5795	121.16	-	-	111.22	33.1	10.01	33.17	100	245	P	H
	*	5795	112.6	-	-	102.66	33.1	10.01	33.17	100	245	A	H
		5852	83.95	-33.69	117.64	73.89	33.23	10.02	33.19	100	245	P	H
		5861.2	81.09	-27.97	109.06	71.01	33.27	10.02	33.21	100	245	P	H
		5879	76.19	-26.04	102.23	66.07	33.31	10.02	33.21	100	245	P	H
		5924.6	65.95	-2.54	68.49	55.73	33.43	10.02	33.23	100	245	P	H
		5646.4	62.34	-5.86	68.2	53.1	32.73	9.61	33.1	196	208	P	V
		5697.8	70.74	-32.84	103.58	61.25	32.86	9.75	33.12	196	208	P	V
		5719.4	77.07	-33.56	110.63	67.45	32.94	9.81	33.13	196	208	P	V
		5725	77.04	-45.16	122.2	67.42	32.94	9.81	33.13	196	208	P	V
	*	5795	119.82	-	-	109.88	33.1	10.01	33.17	196	208	P	V
	*	5795	111.3	-	-	101.36	33.1	10.01	33.17	196	208	A	V
		5854.4	82.17	-30	112.17	72.07	33.27	10.02	33.19	196	208	P	V
		5856	79.06	-31.46	110.52	68.96	33.27	10.02	33.19	196	208	P	V
		5876.8	72.18	-31.68	103.86	62.06	33.31	10.02	33.21	196	208	P	V
		5934.4	63.29	-4.91	68.2	53.08	33.43	10.02	33.24	196	208	P	V
Remark	1. No other spurious found. 2. All results are PASS against Peak and Average limit line.												



Band 4 5725~5850MHz
WIFI 802.11n HT40 (Harmonic @ 3m)

WIFI Ant. 1+2	Note	Frequency (MHz)	Level (dBμV/m)	Over Limit (dB)	Limit Line (dBμV/m)	Read Level (dBμV)	Antenna Factor (dB/m)	Cable Loss (dB)	Preamp Factor (dB)	Ant Pos (cm)	Table Pos (deg)	Peak Avg. (P/A)	Pol. (H/V)
802.11n HT40 CH 151 5755MHz		5338	55.03	-13.17	68.2	46.66	32.23	9.17	33.03	100	245	P	H
		11510	55.57	-18.43	74	64.34	38.5	15.45	63	259	172	P	H
		11510	46.51	-7.49	54	55.28	38.5	15.45	63	259	172	A	H
		17265	53.58	-14.62	68.2	54.05	40.74	19.26	60.83	100	0	P	H
		11510	52.94	-21.06	74	61.99	38.5	15.45	63	100	281	P	V
		11510	44.84	-9.16	54	53.89	38.5	15.45	63	100	281	A	V
		17265	51.75	-16.45	68.2	52.22	40.74	19.26	60.83	100	0	P	V
802.11n HT40 CH 159 5795MHz		11590	55.74	-18.26	74	64.28	38.57	15.51	62.9	255	172	P	H
		11590	48.17	-5.83	54	56.71	38.57	15.51	62.9	255	172	A	H
		17385	54.15	-14.05	68.2	53.81	40.67	19.32	60.02	100	0	P	H
		11590	53.46	-20.54	74	62.28	38.57	15.51	62.9	100	176	P	V
		11590	45.82	-8.18	54	54.64	38.57	15.51	62.9	100	176	A	V
		17385	50.77	-17.43	68.2	50.43	40.67	19.32	60.02	100	0	P	V
Remark	1. No other spurious found. 2. All results are PASS against Peak and Average limit line.												



Band 4 5725~5850MHz
WIFI 802.11ac VHT80 (Band Edge @ 3m)

WIFI Ant. 1+2	Note	Frequency (MHz)	Level (dBμV/m)	Over Limit (dB)	Limit Line (dBμV/m)	Read Level (dBμV)	Antenna Factor (dB/m)	Cable Loss (dB)	Preamp Factor (dB)	Ant Pos (cm)	Table Pos (deg)	Peak Avg. (P/A)	Pol. (H/V)
802.11ac VHT80 CH 155 5775MHz		5650	67.61	-0.59	68.2	58.33	32.77	9.61	33.1	100	244	P	H
		5698.4	79.04	-24.98	104.02	69.55	32.86	9.75	33.12	100	244	P	H
		5716.6	79.5	-30.35	109.85	69.92	32.9	9.81	33.13	100	244	P	H
		5722.2	80.15	-35.67	115.82	70.53	32.94	9.81	33.13	100	244	P	H
	*	5775	114.01	-	-	104.16	33.06	9.95	33.16	100	244	P	H
	*	5775	106.11	-	-	96.26	33.06	9.95	33.16	100	244	A	H
		5852.2	77.51	-39.67	117.18	67.45	33.23	10.02	33.19	100	244	P	H
		5857.8	77.63	-32.38	110.01	67.55	33.27	10.02	33.21	100	244	P	H
		5880	71.57	-29.92	101.49	61.45	33.31	10.02	33.21	100	244	P	H
		5931.8	63.31	-4.89	68.2	53.09	33.43	10.02	33.23	100	244	P	H
		5650	66.66	-1.54	68.2	57.38	32.77	9.61	33.1	231	210	P	V
		5699.4	74.39	-30.37	104.76	64.9	32.86	9.75	33.12	231	210	P	V
		5717.2	77.72	-32.3	110.02	68.14	32.9	9.81	33.13	231	210	P	V
		5724.4	78.87	-41.96	120.83	69.25	32.94	9.81	33.13	231	210	P	V
	*	5775	113.06	-	-	103.21	33.06	9.95	33.16	231	210	P	V
	*	5775	105.04	-	-	95.19	33.06	9.95	33.16	231	210	A	V
		5854	74.5	-38.58	113.08	64.4	33.27	10.02	33.19	231	210	P	V
		5856.6	74.34	-36.01	110.35	64.24	33.27	10.02	33.19	231	210	P	V
		5876.8	68.08	-35.78	103.86	57.96	33.31	10.02	33.21	231	210	P	V
	5938.6	60.99	-7.21	68.2	50.73	33.48	10.02	33.24	231	210	P	V	
Remark	1. No other spurious found. 2. All results are PASS against Peak and Average limit line.												



Band 4 5725~5850MHz

WIFI 802.11ac VHT80 (Harmonic @ 3m)

WIFI Ant. 1+2	Note	Frequency (MHz)	Level (dBμV/m)	Over Limit (dB)	Limit Line (dBμV/m)	Read Level (dBμV)	Antenna Factor (dB/m)	Cable Loss (dB)	Preamp Factor (dB)	Ant Pos (cm)	Table Pos (deg)	Peak Avg. (P/A)	Pol. (H/V)
802.11ac VHT80 CH 155 5775MHz		11550	53.4	-20.6	74	62.04	38.54	15.48	62.94	261	170	P	H
		11550	44.12	-9.88	54	52.76	38.54	15.48	62.94	261	170	A	H
		17325	48.77	-19.43	68.2	48.88	40.71	19.29	60.48	100	0	P	H
		11550	51.68	-22.32	74	60.6	38.54	15.48	62.94	100	174	P	V
		11550	42.18	-11.82	54	51.1	38.54	15.48	62.94	100	174	A	V
		17325	49.47	-18.73	68.2	49.58	40.71	19.29	60.48	100	0	P	V
Remark	1. No other spurious found. 2. All results are PASS against Peak and Average limit line.												



Emission below 1GHz

5GHz WIFI 802.11ac VHT80 (LF @ 3m)

WIFI Ant.	Note	Frequency	Level	Over Limit	Limit Line	Read Level	Antenna Factor	Cable Loss	Preamp Factor	Ant Pos	Table Pos	Peak Avg.	Pol.
1+2		(MHz)	(dBμV/m)	(dB)	(dBμV/m)	(dBμV)	(dB/m)	(dB)	(dB)	(cm)	(deg)	(P/A)	(H/V)
5GHz 802.11ac VHT80 LF		31.35	21.99	-18.01	40	29.8	23.84	0.82	32.49	-	-	P	H
		126.93	28.33	-15.17	43.5	41.67	17.56	1.51	32.46	-	-	P	H
		152.04	31.31	-12.19	43.5	45.16	16.89	1.61	32.43	100	302	P	H
		342.7	28.38	-17.62	46	38.22	20.07	2.39	32.35	-	-	P	H
		633.9	28.14	-17.86	46	30.93	26.42	3.15	32.46	-	-	P	H
		947.5	33.47	-12.53	46	30.02	30.69	3.82	31.23	-	-	P	H
		39.45	27.66	-12.34	40	39.95	19.37	0.82	32.49	100	221	P	V
		59.43	25.81	-14.19	40	45.45	11.81	1.02	32.49	-	-	P	V
		189.84	28.53	-14.97	43.5	44.42	14.74	1.69	32.4	-	-	P	V
		465.9	26.45	-19.55	46	32.51	23.49	2.77	32.36	-	-	P	V
		753.6	31.32	-14.68	46	31.9	28.16	3.44	32.31	-	-	P	V
	947.5	33.54	-12.46	46	30.09	30.69	3.82	31.23	-	-	P	V	
Remark	1. No other spurious found. 2. All results are PASS against limit line.												



Note symbol

*	Fundamental Frequency which can be ignored. However, the level of any unwanted emissions shall not exceed the level of the fundamental frequency.
!	Test result is over limit line.
P/A	Peak or Average
H/V	Horizontal or Vertical



A calculation example for radiated spurious emission is shown as below:

WIFI	Note	Frequency	Level	Over	Limit	Read	Antenna	Cable	Preamp	Ant	Table	Peak	Pol.
Ant.				Limit	Line	Level	Factor	Loss	Factor	Pos	Pos	Avg.	
1+2		(MHz)	(dBμV/m)	(dB)	(dBμV/m)	(dBμV)	(dB/m)	(dB)	(dB)	(cm)	(deg)	(P/A)	(H/V)
802.11b		2390	55.45	-18.55	74	54.51	32.22	4.58	35.86	103	308	P	H
CH 01													
2412MHz		2390	43.54	-10.46	54	42.6	32.22	4.58	35.86	103	308	A	H

1. Level(dBμV/m) =

Antenna Factor(dB/m) + Cable Loss(dB) + Read Level(dBμV) - Preamp Factor(dB)

2. Over Limit(dB) = Level(dBμV/m) – Limit Line(dBμV/m)

For Peak Limit @ 2390MHz:

1. Level(dBμV/m)

= Antenna Factor(dB/m) + Cable Loss(dB) + Read Level(dBμV) - Preamp Factor(dB)

= 32.22(dB/m) + 4.58(dB) + 54.51(dBμV) – 35.86 (dB)

= 55.45 (dBμV/m)

2. Over Limit(dB)

= Level(dBμV/m) – Limit Line(dBμV/m)

= 55.45(dBμV/m) – 74(dBμV/m)

= -18.55(dB)

For Average Limit @ 2390MHz:

1. Level(dBμV/m)

= Antenna Factor(dB/m) + Cable Loss(dB) + Read Level(dBμV) - Preamp Factor(dB)

= 32.22(dB/m) + 4.58(dB) + 42.6(dBμV) – 35.86 (dB)

= 43.54 (dBμV/m)

2. Over Limit(dB)

= Level(dBμV/m) – Limit Line(dBμV/m)

= 43.54(dBμV/m) – 54(dBμV/m)

= -10.46(dB)

Both peak and average measured complies with the limit line, so test result is “PASS”.



Appendix D. Radiated Spurious Emission Plots

Test Engineer :	J.C. Liang, Jacky Huang, Ken Wu	Temperature :	20~24°C
		Relative Humidity :	50~54%

Note symbol

-L	Low channel location
-R	High channel location



Band 4 - 5725~5850MHz
WIFI 802.11a (Band Edge @ 3m)

WIFI	Band 4 5725~5850MHz Band Edge @ 3m	
ANT	802.11a CH149 5745MHz	
1+2	Horizontal	Fundamental
Peak	<p>Site : 03CH11-HY Condition : PEAK_BE(B4) 16-24 3m HORN 9120D-HF HORIZONTAL</p>	<p>Site : 03CH11-HY Condition : PEAK(UWB) 3m HORN 9120D-HF HORIZONTAL</p>



WIFI	Band 4 5725~5850MHz Band Edge @ 3m	
ANT	802.11a CH149 5745MHz	
1+2	Vertical	Fundamental
Peak	<p>Site : 03CH11-HY Condition : PEAK_BE(B4) 16-24 3m HORN 9120D-HF VERTICAL</p>	<p>Site : 03CH11-HY Condition : PEAK(U1) 3m HORN 9120D-HF VERTICAL</p>



WIFI	Band 4 5725~5850MHz Band Edge @ 3m	
ANT	802.11a CH157 5785MHz	
1+2	Horizontal	Fundamental
<p>Peak</p>	<p>Site : 03CH11-HY Condition : PEAK_BE(04) 16-24 3m HORN 9120D-HF HORIZONTAL</p>	<p>Site : 03CH11-HY Condition : PEAK(04) 3m HORN 9120D-HF HORIZONTAL</p>
<p>Peak</p>	<p>Site : 03CH11-HY Condition : PEAK_BE(04) 16-24 3m HORN 9120D-HF HORIZONTAL</p>	<p>Left blank</p>

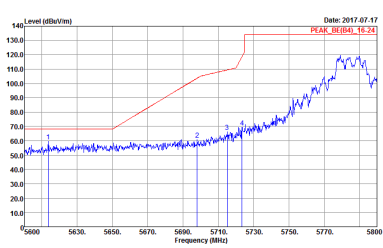
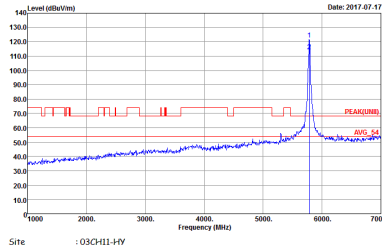
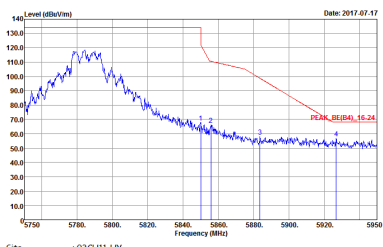

WIFI	Band 4 5725~5850MHz Band Edge @ 3m	
ANT	802.11a CH157 5785MHz	
1+2	Vertical	Fundamental
<p>Peak</p>	 <p>Site : 03CH11-HY Condition : PEAK_BE(B4) 16-24 3m HORN 9120D-HF VERTICAL</p>	 <p>Site : 03CH11-HY Condition : PEAK(UWB) 3m HORN 9120D-HF VERTICAL</p>
<p>Peak</p>	 <p>Site : 03CH11-HY Condition : PEAK_BE(B4) 16-24 3m HORN 9120D-HF VERTICAL</p>	<p>Left blank</p>



WIFI	Band 4 5725~5850MHz Band Edge @ 3m	
ANT	802.11a CH165 5825MHz	
1+2	Horizontal	Fundamental
Peak	<p>Site : 03CH11-HY Condition : PEAK_BE(B4) 16-24 3m HORN 9120D-HF HORIZONTAL</p>	<p>Site : 03CH11-HY Condition : PEAK(UIN3) 3m HORN 9120D-HF HORIZONTAL</p>

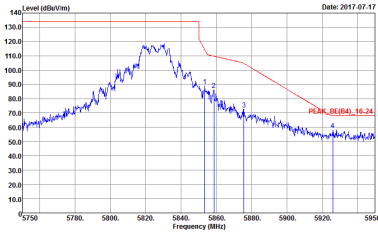
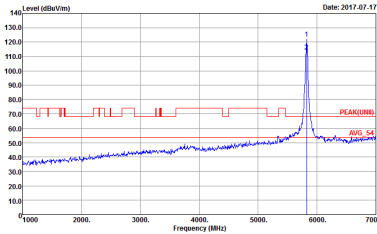

WIFI	Band 4 5725~5850MHz Band Edge @ 3m	
ANT	802.11a CH165 5825MHz	
1+2	Vertical	Fundamental
Peak	 <p>Site : 03CH11-HY Condition : PEAK_BET(B4) 16-24 3m HORN 9120D-HF VERTICAL</p>	 <p>Site : 03CH11-HY Condition : PEAK(FUN1) 3m HORN 9120D-HF VERTICAL</p>



Band 4 5725~5850MHz
WIFI 802.11n HT20 (Band Edge @ 3m)

WIFI	Band 4 5725~5850MHz Band Edge @ 3m	
ANT	802.11n HT20 CH149 5745MHz	
1+2	Horizontal	Fundamental
Peak	<p>Site : 03CH11-HY Condition : PEAK BE(B4) 16-24 3m HORN 9120D-HF HORIZONTAL</p>	<p>Site : 03CH11-HY Condition : PEAK(LINB) 3m HORN 9120D-HF HORIZONTAL</p>

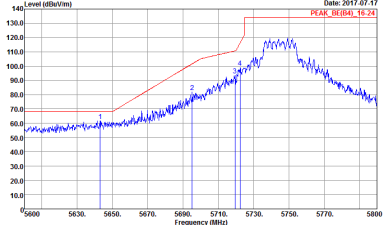
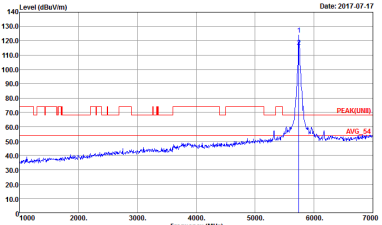

WIFI	Band 4 5725~5850MHz Band Edge @ 3m	
ANT	802.11n HT20 CH149 5745MHz	
1+2	Vertical	Fundamental
Peak	 <p>Site : 03CH11-HY Condition : PEAK BE(B4) 16-24 3m HORN 9120D-HF VERTICAL</p>	 <p>Site : 03CH11-HY Condition : PEAK(FUN1) 3m HORN 9120D-HF VERTICAL</p>



WIFI	Band 4 5725~5850MHz Band Edge @ 3m	
ANT	802.11n HT20 CH157 5785MHz	
1+2	Horizontal	Fundamental
Peak	<p>Site : 03CH11-HY Condition : PEAK_BE(B4) 16-24 3m HORN 9120D-HF HORIZONTAL</p>	<p>Site : 03CH11-HY Condition : PEAK(UINII) 3m HORN 9120D-HF HORIZONTAL</p>
Peak	<p>Site : 03CH11-HY Condition : PEAK_BE(B4) 16-24 3m HORN 9120D-HF HORIZONTAL</p>	Left blank



WIFI	Band 4 5725~5850MHz Band Edge @ 3m	
ANT	802.11n HT20 CH157 5785MHz	
1+2	Vertical	Fundamental
Peak	<p>Site : 03CH11-HY Condition : PEAK_BE(B4) 16-24 3m HORN 9120D-HF VERTICAL</p>	<p>Site : 03CH11-HY Condition : PEAK(UWB) 3m HORN 9120D-HF VERTICAL</p>
Peak	<p>Site : 03CH11-HY Condition : PEAK_BE(B4) 16-24 3m HORN 9120D-HF VERTICAL</p>	Left blank

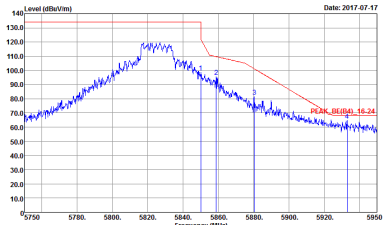
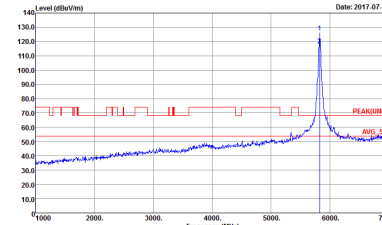

WIFI	Band 4 5725~5850MHz Band Edge @ 3m	
ANT	802.11n HT20 CH165 5825MHz	
1+2	Horizontal	Fundamental
Peak	 <p>Site : 03CH11-HY Condition : PEAK BE(B4) 16-24 3m HORN 9120D-HF HORIZONTAL</p>	 <p>Site : 03CH11-HY Condition : PEAK(UWB) 3m HORN 9120D-HF HORIZONTAL</p>

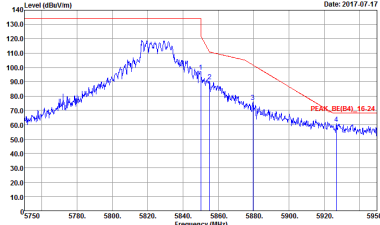
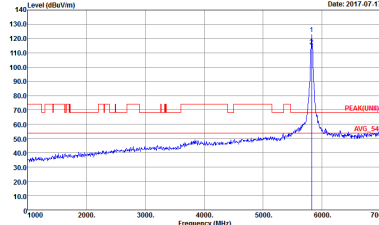

WIFI	Band 4 5725~5850MHz Band Edge @ 3m	
ANT	802.11n HT20 CH165 5825MHz	
1+2	Vertical	Fundamental
Peak	 <p>Site : 03CH11-HY Condition : PEAK_BE(B4) 16-24 3m HORN 9120D-HF VERTICAL</p>	 <p>Site : 03CH11-HY Condition : PEAK(UWB) 3m HORN 9120D-HF VERTICAL</p>



**Band 4 5725~5850MHz
WIFI 802.11n HT40 (Band Edge @ 3m)**

WIFI	Band 4 5725~5850MHz Band Edge @ 3m	
ANT	802.11n HT40 CH151 5755MHz	
1+2	Horizontal	Fundamental
Peak	<p>Site : 03CH11-HY Condition : PEAK_BE(B4) 16-24 3m HORN 9120D-HF HORIZONTAL</p>	<p>Site : 03CH11-HY Condition : PEAKUNIII 3m HORN 9120D-HF HORIZONTAL</p>
Peak	<p>Site : 03CH11-HY Condition : PEAK_BE(B4) 16-24 3m HORN 9120D-HF HORIZONTAL</p>	Left blank



WIFI	Band 4 5725~5850MHz Band Edge @ 3m	
ANT	802.11n HT40 CH151 5755MHz	
1+2	Vertical	Fundamental
<p>Peak</p>		
<p>Peak</p>		<p>Left blank</p>

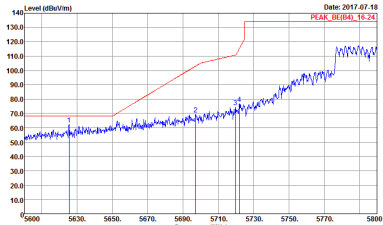
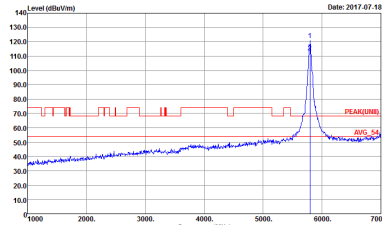
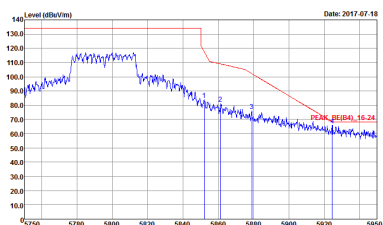

WIFI	Band 4 5725~5850MHz Band Edge @ 3m	
ANT	802.11n HT40 CH159 5795MHz	
1+2	Horizontal	Fundamental
Peak	 <p>Site : 03CH11-HY Condition : PEAK_BE(B4) 16-24 3m HORN 9120D-HF HORIZONTAL</p>	 <p>Site : 03CH11-HY Condition : PEAK(UWB) 3m HORN 9120D-HF HORIZONTAL</p>
Peak	 <p>Site : 03CH11-HY Condition : PEAK_BE(B4) 16-24 3m HORN 9120D-HF HORIZONTAL</p>	Left blank



WIFI	Band 4 5725~5850MHz Band Edge @ 3m	
ANT	802.11n HT40 CH159 5795MHz	
1+2	Vertical	Fundamental
<p>Peak</p>	<p>Site : 03CH11-HY Condition : PEAK_BE(84) 16-24 3m HORN 9120D-HF VERTICAL</p>	<p>Site : 03CH11-HY Condition : PEAK(U8) 3m HORN 9120D-HF VERTICAL</p>
<p>Peak</p>	<p>Site : 03CH11-HY Condition : PEAK_BE(84) 16-24 3m HORN 9120D-HF VERTICAL</p>	<p>Left blank</p>

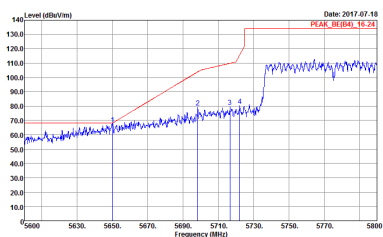
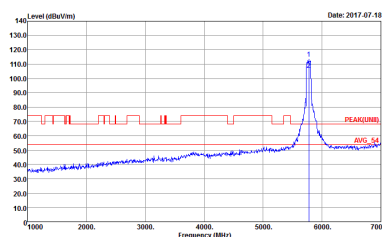
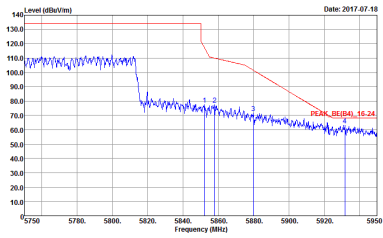

**Band 4 5725~5850MHz
WIFI 802.11ac VHT80 (Band Edge @ 3m)**

WIFI	Band 4 5725~5850MHz Band Edge @ 3m	
ANT	802.11ac VHT80 CH155 5775MHz	
1+2	Horizontal	Fundamental
Peak	 <p>Site : 03CH11-HY Condition : PEAK_BE(B4) 16-24 3m HORN 9120D-HF HORIZONTAL</p>	 <p>Site : 03CH11-HY Condition : PEAK(LINB) 3m HORN 9120D-HF HORIZONTAL</p>
Peak	 <p>Site : 03CH11-HY Condition : PEAK_BE(B4) 16-24 3m HORN 9120D-HF HORIZONTAL</p>	Left blank

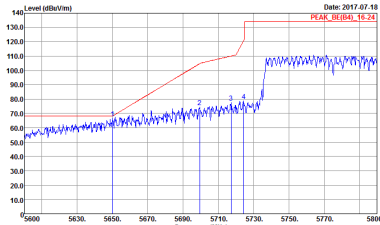
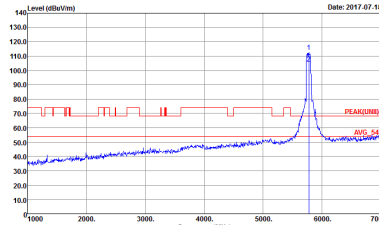
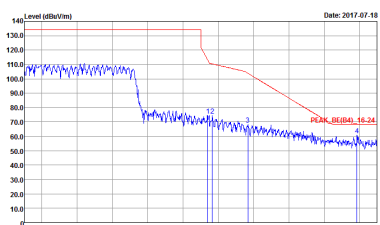

WIFI	Band 4 5725~5850MHz Band Edge @ 3m	
ANT	802.11ac VHT80 CH155 5775MHz	
1+2	Vertical	Fundamental
Peak	 <p>Site : 03CH11-HY Condition : PEAK_BE(B4) 16-24 3m HORN 9120D-HF VERTICAL</p>	 <p>Site : 03CH11-HY Condition : PEAK(LIN) 3m HORN 9120D-HF VERTICAL</p>
Peak	 <p>Site : 03CH11-HY Condition : PEAK_BE(B4) 16-24 3m HORN 9120D-HF VERTICAL</p>	Left blank



Band 4 - 5725~5850MHz
WIFI 802.11a (Harmonic @ 3m)

WIFI	Band 4 5725~5850MHz Harmonic @ 3m	
ANT	802.11a CH149 5745MHz	
1+2	Horizontal	Vertical
Peak Avg.	<p>Site : 03CH11-HY Condition : PEAK(UNII) 3m 9170 SHF HORM 150809 HORIZONTAL</p>	<p>Site : 03CH11-HY Condition : PEAK(UNII) 3m 9170 SHF HORM 150809 VERTICAL</p>



WIFI	Band 4 5725~5850MHz Harmonic @ 3m	
ANT	802.11a CH157 5785MHz	
1+2	Horizontal	Vertical
Peak Avg.	<p>Site : 03CH11-HY Condition : PEAK(UNII) 3m 9170 SHF HORM 150809 HORIZONTAL</p>	<p>Site : 03CH11-HY Condition : PEAK(UNII) 3m 9170 SHF HORM 150809 VERTICAL</p>



WIFI	Band 4 5725~5850MHz Harmonic @ 3m	
ANT	802.11a CH165 5825MHz	
1+2	Horizontal	Vertical
Peak Avg.	<p>Site : 03CH11-HY Condition : PEAK(LINE1) 3m 9170 SH-F HORM 150809 HORIZONTAL</p>	<p>Site : 03CH11-HY Condition : PEAK(LINE1) 3m 9170 SH-F HORM 150809 VERTICAL</p>



Band 4 5725~5850MHz
WIFI 802.11n HT20 (Harmonic @ 3m)

WIFI	Band 4 5725~5850MHz Harmonic @ 3m	
ANT	802.11n HT20 CH149 5745MHz	
1+2	Horizontal	Vertical
Peak Avg.	<p>Site : 03CH11-HY Condition : PEAK(LINE1) 3m 9170 SHF HORM 150809 HORIZONTAL</p>	<p>Site : 03CH11-HY Condition : PEAK(LINE1) 3m 9170 SHF HORM 150809 VERTICAL</p>

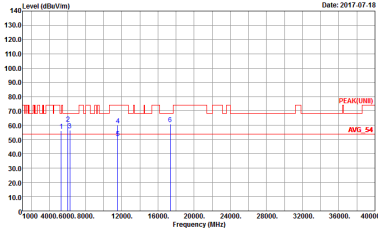
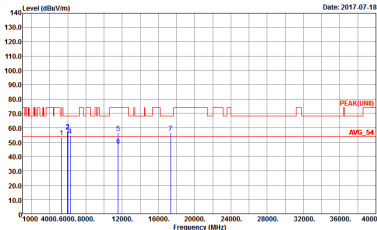

WIFI	Band 4 5725~5850MHz Harmonic @ 3m	
ANT	802.11n HT20 CH157 5785MHz	
1+2	Horizontal	Vertical
Peak Avg.	 <p>Site : 03CH11-HY Condition : PEAK(UNII) 3m 9170 SH-F HORM 150809 HORIZONTAL</p>	 <p>Site : 03CH11-HY Condition : PEAK(UNII) 3m 9170 SH-F HORM 150809 VERTICAL</p>



WIFI	Band 4 5725~5850MHz Harmonic @ 3m	
ANT	802.11n HT20 CH165 5825MHz	
1+2	Horizontal	Vertical
Peak Avg.	<p>Site : 03CH11-HY Condition : PEAK(LINE1) 3m 9170 SHF HORM 150809 HORIZONTAL</p>	<p>Site : 03CH11-HY Condition : PEAK(LINE1) 3m 9170 SHF HORM 150809 VERTICAL</p>

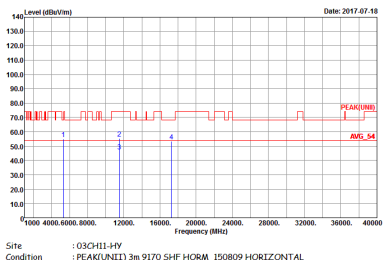
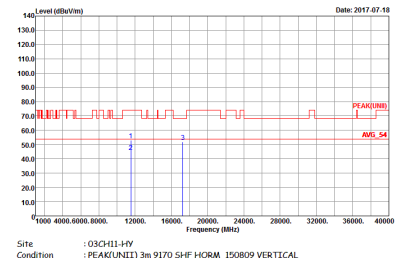

Band 4 5725~5850MHz
WIFI 802.11n HT40 (Harmonic @ 3m)

WIFI	Band 4 5725~5850MHz Harmonic @ 3m	
ANT	802.11n HT40 CH151 5755MHz	
1+2	Horizontal	Vertical
Peak Avg.	 <p>Site : 03CH11-HY Condition : PEAK(LINE1) 3m 9170 SHF HORM 150809 HORIZONTAL</p>	 <p>Site : 03CH11-HY Condition : PEAK(LINE1) 3m 9170 SHF HORM 150809 VERTICAL</p>



WIFI	Band 4 5725~5850MHz Harmonic @ 3m	
ANT	802.11n HT40 CH159 5795MHz	
1+2	Horizontal	Vertical
Peak Avg.	<p>Site : 03CH11-HY Condition : PEAK(LINE1) 3m 9170 SHF HORM 150809 HORIZONTAL</p>	<p>Site : 03CH11-HY Condition : PEAK(LINE1) 3m 9170 SHF HORM 150809 VERTICAL</p>

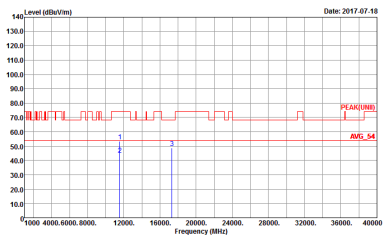
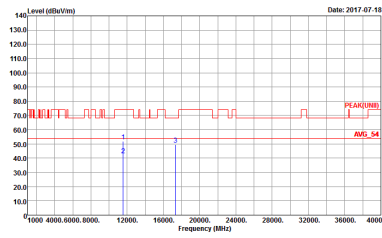

**Band 4 5725~5850MHz
WIFI 802.11ac VHT80 (Harmonic @ 3m)**

WIFI	Band 4 5725~5850MHz Harmonic @ 3m	
ANT	802.11ac VHT80 CH155 5775MHz	
1+2	Horizontal	Vertical
Peak Avg.	<div style="display: flex; justify-content: space-around;"> <div style="width: 45%;">  <p>Site : 03CH11-HY Condition : PEAK(LINE1) 3m 9170 SHF HORM 150809 HORIZONTAL</p> </div> <div style="width: 45%;">  <p>Site : 03CH11-HY Condition : PEAK(LINE1) 3m 9170 SHF HORM 150809 VERTICAL</p> </div> </div>	



Emission below 1GHz
5GHz WIFI 802.11ac VHT80 (LF)

WIFI	5GHz 5725~5850MHz	
ANT	802.11ac VHT80 LF	
1+2	Horizontal	Vertical
QP / Peak	<p>Site : 03CH11-HY Condition : QP 3m BE-LOG 6111D-LF ETC HORIZONTAL</p>	<p>Site : 03CH11-HY Condition : QP 3m BE-LOG 6111D-LF ETC VERTICAL</p>



Appendix E. Duty Cycle Plots

Antenna	Band	Duty Cycle(%)	T(us)	1/T(kHz)	VBW Setting	Duty Factor(dB)
1 + 2	802.11a for Ant. 1	99.05	-	-	10Hz	0.04
1 + 2	802.11a for Ant. 2	98.81	-	-	10Hz	0.05
1 + 2	5GHz 802.11n HT20 for Ant. 1	98.47	-	-	10Hz	0.07
1 + 2	5GHz 802.11n HT20 for Ant. 2	98.97	-	-	10Hz	0.04
1 + 2	5GHz 802.11n HT40 for Ant. 1	98.26	-	-	10Hz	0.08
1 + 2	5GHz 802.11n HT40 for Ant. 2	98.26	-	-	10Hz	0.08
1 + 2	5GHz 802.11ac VHT80 for Ant. 1	98.12	-	-	10Hz	0.08
1 + 2	5GHz 802.11ac VHT80 for Ant. 2	98.12	-	-	10Hz	0.08



MIMO <Ant. 1>

802.11a

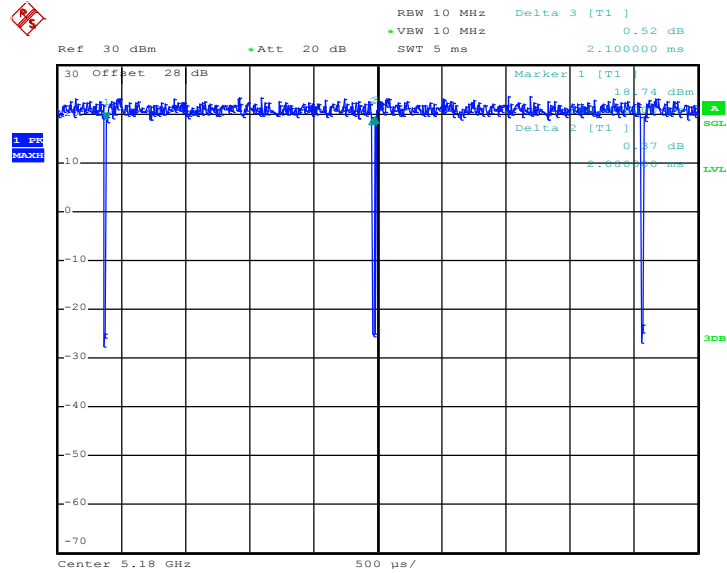

Date: 5.JUL.2017 01:09:23

802.11n HT20

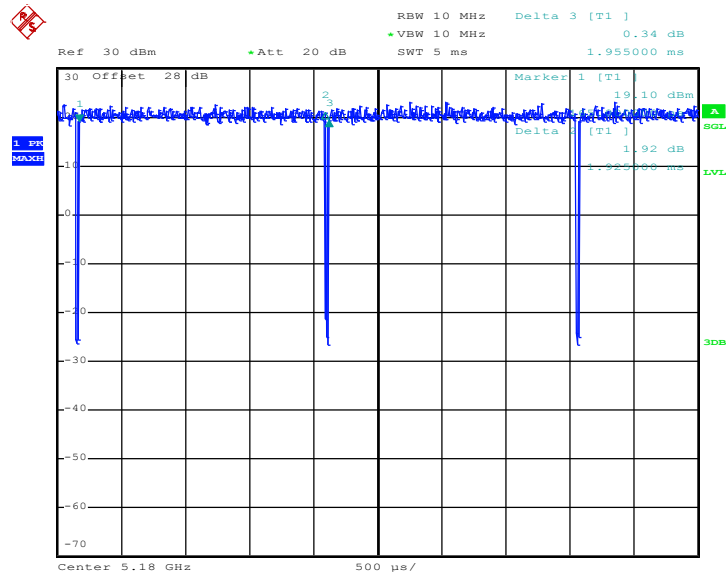

Date: 5.JUL.2017 01:12:47



802.11n HT40

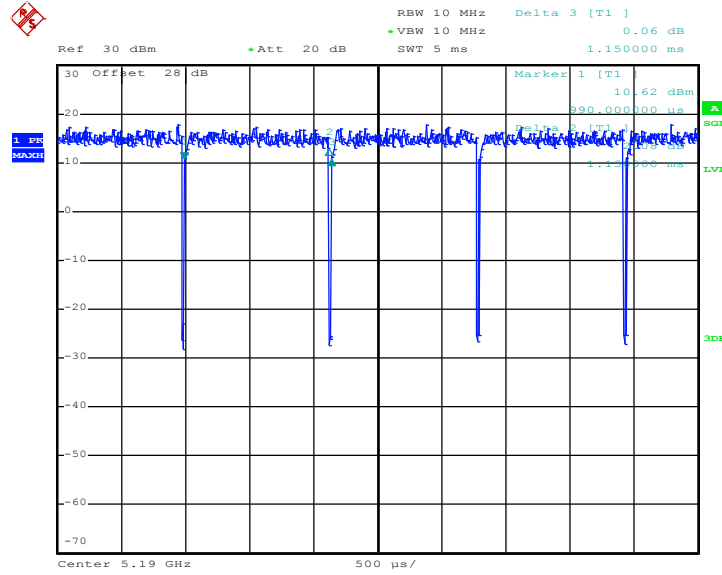

Date: 8.JUL.2017 12:11:34

802.11ac VHT80

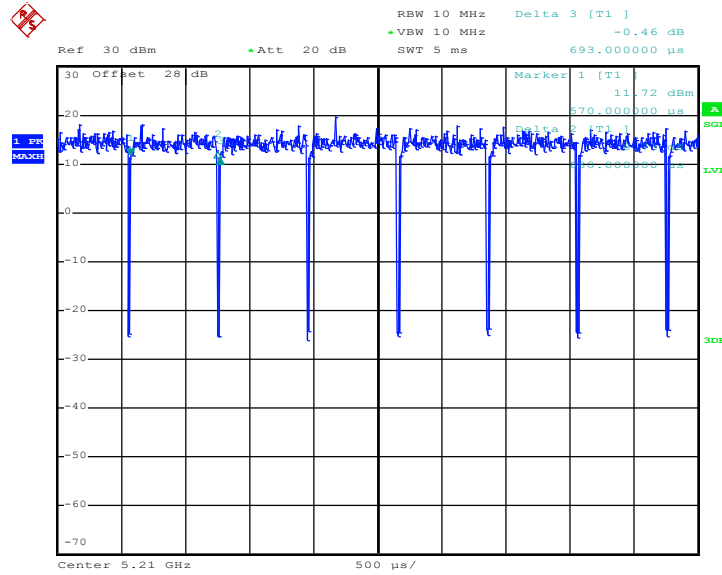

Date: 5.JUL.2017 01:58:15



MIMO <Ant. 2>

802.11a

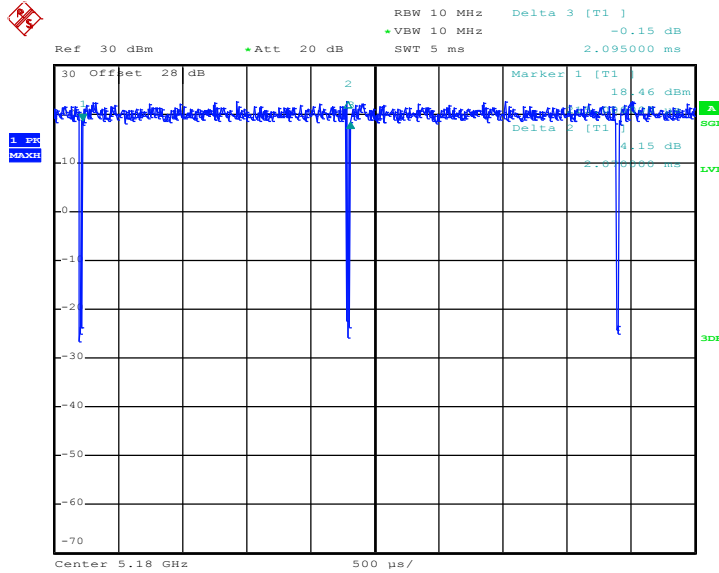

Date: 5.JUL.2017 01:09:52

802.11n HT20

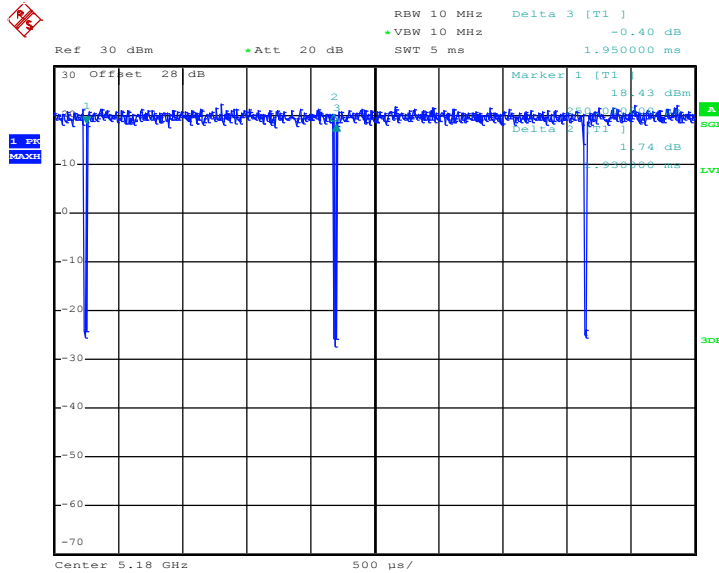

Date: 5.JUL.2017 01:13:16



802.11n HT40

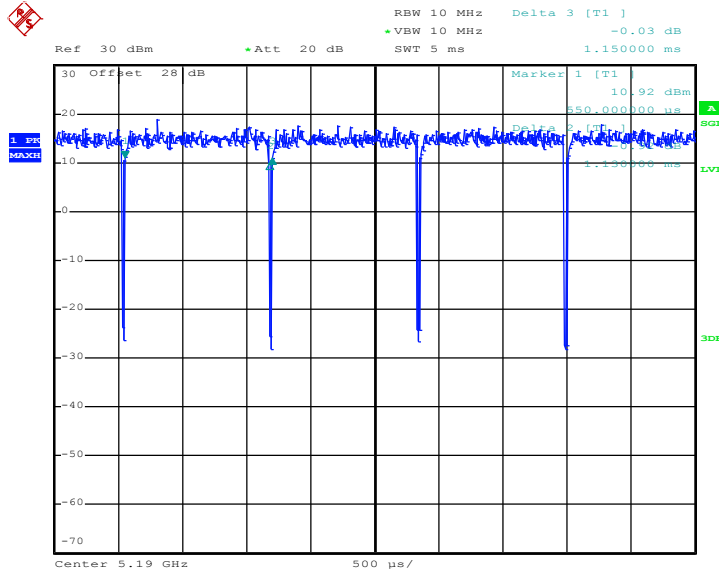

Date: 8.JUL.2017 12:10:50

802.11ac VHT80

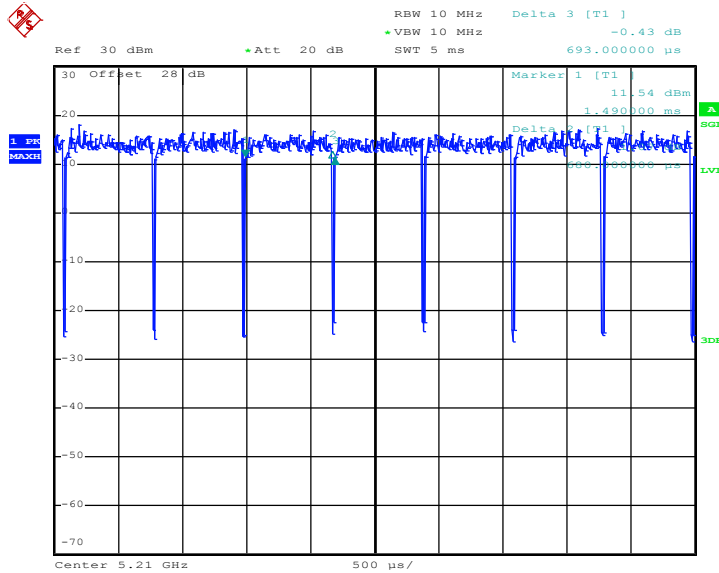

Date: 5.JUL.2017 01:59:11