



# FCC RF Test Report

**APPLICANT** : Nest Labs Inc.  
**EQUIPMENT** : OUTDOOR SECURITY CAMERA  
**MODEL NAME** : NEST CAM IQ  
**MODEL NUMBER** : A0055  
**FCC ID** : ZQANC41  
**STANDARD** : FCC Part 15 Subpart E §15.407  
**CLASSIFICATION** : (NII) Unlicensed National Information Infrastructure

The product was completed on Sep. 07, 2017. We, SPORTON INTERNATIONAL INC., would like to declare that the tested sample has been evaluated in accordance with the test procedures and has been in compliance with the applicable technical standards.

The test results in this report apply exclusively to the tested model / sample. Without written approval of SPORTON INTERNATIONAL INC., the test report shall not be reproduced except in full.

Reviewed by: Joseph Lin / Supervisor

Approved by: Jones Tsai / Manager



Testing Laboratory  
1190

## **SPORTON INTERNATIONAL INC.**

No. 52, Hwa Ya 1<sup>st</sup> Rd., Hwa Ya Technology Park, Kwei-Shan District, Tao Yuan City, Taiwan, R.O.C.



# TABLE OF CONTENTS

**REVISION HISTORY..... 3**

**SUMMARY OF TEST RESULT ..... 4**

**1 GENERAL DESCRIPTION ..... 5**

    1.1 Applicant ..... 5

    1.2 Product Feature of Equipment Under Test..... 5

    1.3 Modification of EUT ..... 5

    1.4 Testing Location ..... 6

    1.5 Applicable Standards..... 6

**2 TEST CONFIGURATION OF EQUIPMENT UNDER TEST ..... 7**

    2.1 Carrier Frequency and Channel ..... 7

    2.2 Test Mode..... 9

    2.3 Connection Diagram of Test System..... 12

    2.4 Support Unit used in test configuration and system ..... 13

    2.5 EUT Operation Test Setup ..... 13

    2.6 Measurement Results Explanation Example..... 13

**3 TEST RESULT ..... 14**

    3.1 26dB & 99% Occupied Bandwidth Measurement ..... 14

    3.2 Maximum Conducted Output Power Measurement ..... 18

    3.3 Power Spectral Density Measurement ..... 20

    3.4 Unwanted Emissions Measurement..... 23

    3.5 AC Conducted Emission Measurement..... 28

    3.6 Frequency Stability Measurement..... 30

    3.7 Automatically Discontinue Transmission ..... 31

    3.8 Antenna Requirements ..... 33

**4 LIST OF MEASURING EQUIPMENT ..... 34**

**5 UNCERTAINTY OF EVALUATION ..... 35**

**APPENDIX A. CONDUCTED TEST RESULTS**

**APPENDIX B. AC CONDUCTED EMISSION TEST RESULT**

**APPENDIX C. RADIATED SPURIOUS EMISSION**

**APPENDIX D. RADIATED SPURIOUS EMISSION PLOTS**

**APPENDIX E. DUTY CYCLE PLOTS**



### REVISION HISTORY

REPORT NO.	VERSION	DESCRIPTION	ISSUED DATE
FR6N0107-01D	Rev. 01	Initial issue of report	Aug. 29, 2017
FR6N0107-01D	Rev. 02	<ol style="list-style-type: none"> <li>1. Revising connection diagram of test system in section 2.3.</li> <li>2. Add the test description of straddle channel in section 3.1.1, 3.2.1, and 3.3.1.</li> <li>3. Add the test description of MIMO mode in section 2.2.</li> <li>4. Add test data of duty factor and frequency stability in appendix a and appendix e.</li> </ol>	Sep. 05, 2017
FR6N0107-01D	Rev. 03	Revising conducted emission data of appendix B and connection diagram of test system in section 2.3 and updating appendix A.	Sep. 07, 2017
FR6N0107-01D	Rev. 04	Revising conducted emission test mode in section 2.2 and connection diagram of test system in section 2.3 and updating setup photographs.	Sep. 08, 2017
FR6N0107-01D	Rev. 05	Updating report of adding 6dB Bandwidth testing description and conducted emission test mode	Sep. 11, 2017



### SUMMARY OF TEST RESULT

Report Section	FCC Rule	Description	Limit	Result
3.1	2.1049 15.403(i)	26dB & 99% Bandwidth	-	Pass
3.2	15.407(a)	Maximum Conducted Output Power	≤ 24 dBm (depend on band)	Pass
3.3	15.407(a)	Power Spectral Density	≤ 11 dBm (depend on band)	Pass
3.4	15.407(b)	Unwanted Emissions	≤ -17, -27 dBm &15.209(a)	Pass
3.5	15.207	AC Conducted Emission	15.207(a)	Pass
3.6	15.407(g)	Frequency Stability	Within Operation Band	Pass
3.7	15.407(c)	Automatically Discontinue Transmission	Discontinue Transmission	Pass
3.8	15.203 & 15.407(a)	Antenna Requirement	N/A	Pass



# 1 General Description

## 1.1 Applicant

Nest Labs Inc.  
3400 Hillview Ave. Palo Alto, CA 94304 USA

## 1.2 Product Feature of Equipment Under Test

Bluetooth-LE, Wi-Fi 2.4GHz 802.11b/g/n/ac, and Wi-Fi 5GHz 802.11a/n/ac, 15.4

Product Specification subjective to this standard	
Antenna Type	WLAN: IFA Antenna Bluetooth: IFA Antenna 15.4: IFA Antenna

## 1.3 Modification of EUT

No modifications are made to the EUT during all test items.



### 1.4 Testing Location

Sporton Lab is accredited to ISO 17025 by Taiwan Accreditation Foundation (TAF code : 1190) and the FCC designation No. TW0007 under the FCC 2.948(e) by Mutual Recognition Agreement (MRA) in FCC Test.

<b>Test Site</b>	SPORTON INTERNATIONAL INC.	
<b>Test Site Location</b>	No. 52, Hwa Ya 1 <sup>st</sup> Rd., Hwa Ya Technology Park, Kwei-Shan District, Tao Yuan City, Taiwan, R.O.C. TEL: +886-3-327-3456 FAX: +886-3-328-4978	
<b>Test Site No.</b>	<b>Sporton Site No.</b>	
	TH05-HY	CO05-HY

**Note:** The test site complies with ANSI C63.4 2014 requirement.

<b>Test Site</b>	SPORTON INTERNATIONAL INC.	
<b>Test Site Location</b>	No.58, Aly. 75, Ln. 564, Wenhua 3rd Rd. Guishan Dist, Taoyuan City, Taiwan (R.O.C.) TEL: +886-3-327-0868 FAX: +886-3-327-0855	
<b>Test Site No.</b>	<b>Sporton Site No.</b>	
	03CH11-HY	

**Note:** The test site complies with ANSI C63.4 2014 requirement.

### 1.5 Applicable Standards

According to the specifications of the manufacturer, the EUT must comply with the requirements of the following standards:

- ♦ FCC Part 15 Subpart E
- ♦ FCC KDB 789033 D02 General UNII Test Procedures New Rules v01r04.
- ♦ FCC KDB 662911 D01 Multiple Transmitter Output v02r01.
- ♦ ANSI C63.10-2013

**Remark:** All test items were verified and recorded according to the standards and without any deviation during the test.



## 2 Test Configuration of Equipment Under Test

- a. The EUT has been associated with peripherals and configuration operated in a manner tended to maximize its emission characteristics in a typical application. Frequency range investigated: conduction emission (150 kHz to 30 MHz), radiation emission (9 kHz to the 10th harmonic of the highest fundamental frequency or to 40 GHz, whichever is lower). For radiated measurement, pre-scanned in four orthogonal panels, X, Y, Z, Back. The worst cases (Back plane) were recorded in this report.
- b. AC power line Conducted Emission was tested under maximum output power.

### 2.1 Carrier Frequency and Channel

Frequency Band	Channel	Freq. (MHz)	Channel	Freq. (MHz)
5150-5250 MHz Band 1 (U-NII-1)	36	5180	44	5220
	38*	5190	46*	5230
	40	5200	48	5240
	42#	5210		

Frequency Band	Channel	Freq. (MHz)	Channel	Freq. (MHz)
5250-5350 MHz Band 2 (U-NII-2A)	52	5260	60	5300
	54*	5270	62*	5310
	56	5280	64	5320
	58#	5290		

Frequency Band	Channel	Freq. (MHz)	Channel	Freq. (MHz)
5470-5725 MHz Band 3 (U-NII-2C)	100	5500	112	5560
	102*	5510	116	5580
	104	5520	132	5660
	106#	5530	134*	5670
	108	5540	136	5680
	110*	5550	140	5700



Frequency Band	Channel	Freq. (MHz)	Channel	Freq. (MHz)
TDWR Channel	118*	5590	124	5620
	120	5600	126*	5630
	122 <sup>#</sup>	5610	128	5640

Frequency Band	Channel	Freq. (MHz)	Channel	Freq. (MHz)
Straddle Channel	138 <sup>#</sup>	5690	144	5720
	142*	5710		

**Note:**

1. The above Frequency and Channel in "\*" were 802.11n HT40 and 802.11ac VHT40.
2. The above Frequency and Channel in "<sup>#</sup>" were 802.11ac VHT80.





## 2.2 Test Mode

Final test mode of conducted test items and radiated spurious emissions are considering the modulation and worse data rates as below table.

### MIMO Antenna

Modulation	Data Rate
802.11a	6 Mbps
802.11n HT20	MCS0
802.11n HT40	MCS0
802.11ac VHT20	MCS0
802.11ac VHT40	MCS0
802.11ac VHT80	MCS0

Test Cases	
<b>AC Conducted Emission</b>	Mode 1 : WLAN Tx + 15.4 Idle + Speaker on + LED on + RR LED on + IR CUT on + Memory + Camera on + USB Cable (Charging from Adapter 1)
<b>Remark:</b> 1. For radiated spurious emissions, the tests were performed with USB Cable and Adapter 1. 2. The MIMO conducted total power has larger 3dB than SISO conducted power, the RSE test with MIMO condition can also cover the SISO condition.	



Ch. #		Band I : 5150-5250 MHz	Band II : 5250-5350 MHz	Band III : 5470-5725MHz
		802.11a	802.11a	802.11a
L	Low	36	52	100
M	Middle	44	60	116
H	High	48	64	140
Straddle		-	-	144

Ch. #		Band I : 5150-5250 MHz	Band II : 5250-5350 MHz	Band III : 5470-5725MHz
		802.11n HT20	802.11n HT20	802.11n HT20
L	Low	36	52	100
M	Middle	44	60	116
H	High	48	64	140
Straddle		-	-	144

Ch. #		Band I : 5150-5250 MHz	Band II : 5250-5350 MHz	Band III : 5470-5725MHz
		802.11n HT40	802.11n HT40	802.11n HT40
L	Low	38	54	102
M	Middle	-	-	110
H	High	46	62	134
Straddle		-	-	142



Ch. #		Band I : 5150-5250 MHz	Band II : 5250-5350 MHz	Band III : 5470-5725MHz
		802.11ac VHT20	802.11ac VHT20	802.11ac VHT20
L	Low	36	52	100
M	Middle	44	60	116
H	High	48	64	140
Straddle		-	-	144

Ch. #		Band I : 5150-5250 MHz	Band II : 5250-5350 MHz	Band III : 5470-5725MHz
		802.11ac VHT40	802.11ac VHT40	802.11ac VHT40
L	Low	38	54	102
M	Middle	-	-	110
H	High	46	62	134
Straddle		-	-	142

Ch. #		Band I : 5150-5250 MHz	Band II : 5250-5350 MHz	Band III : 5470-5725MHz
		802.11ac VHT80	802.11ac VHT80	802.11ac VHT80
L	Low	-	-	-
M	Middle	42	58	106
H	High	-	-	-
Straddle		-	-	138

## 2.3 Connection Diagram of Test System

<WLAN Tx Mode>

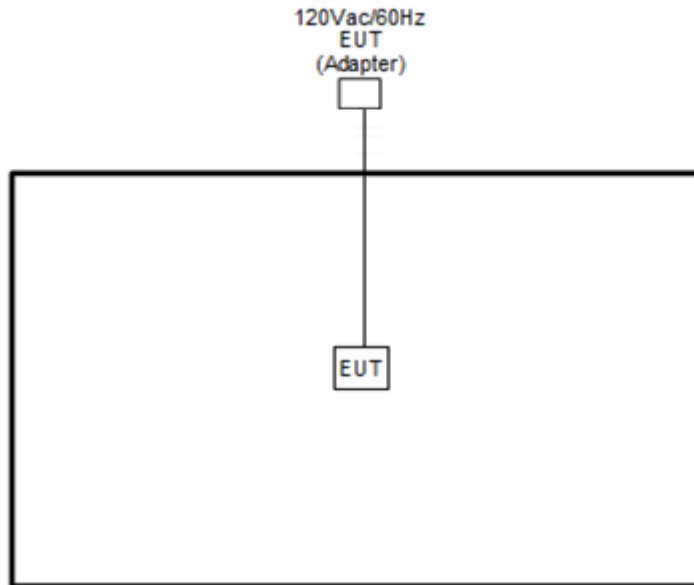

<AC Conducted Emission Mode>

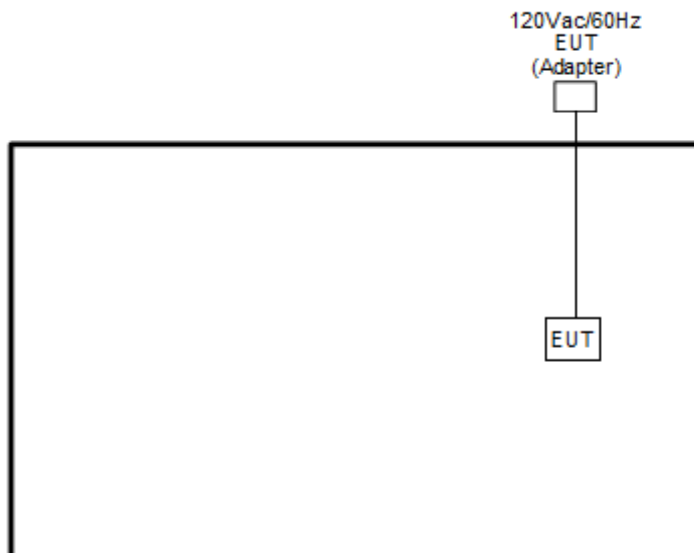



## 2.4 Support Unit used in test configuration and system

Item	Equipment	Trade Name	Model Name	FCC ID	Data Cable	Power Cord
1.	WLAN AP	ASUS	RT-AC66U	MSQ-RTAC66U	N/A	Unshielded, 1.8m
2.	iPod	Apple	A1285	DoC	Shielded, 1.0m	N/A
3.	Notebook	DELL	Latitude E6320	FCC DoC/ Contains FCC ID: QDS-BRCM1054	N/A	AC I/P: Unshielded, 1.2 m DC O/P: Shielded, 1.8 m
4.	USB Cable	N/A	N/A	N/A	Unshielded, 1.93 m	Unshielded, 1.93 m

## 2.5 EUT Operation Test Setup

The RF test items, programmed RF utility, “CMD” installed in the notebook make the EUT provide functions like channel selection and power level for continuous transmitting and receiving signals.

The laptop used for engineering setting purpose only was removed from the EUT, after configured.

## 2.6 Measurement Results Explanation Example

For all conducted test items:

The offset level is set in the spectrum analyzer to compensate the RF cable loss and attenuator factor between EUT conducted output port and spectrum analyzer. With the offset compensation, the spectrum analyzer reading level is exactly the EUT RF output level.

Example :

The spectrum analyzer offset is derived from RF cable loss and attenuator factor.

*Offset = RF cable loss + attenuator factor.*

Following shows an offset computation example with cable loss 4.2 dB and 10dB attenuator.

$$\begin{aligned}
 \text{Offset(dB)} &= \text{RF cable loss(dB)} + \text{attenuator factor(dB)}. \\
 &= 4.2 + 10 = 14.2 \text{ (dB)}
 \end{aligned}$$



### **3 Test Result**

#### **3.1 26dB & 99% Occupied Bandwidth Measurement**

##### **3.1.1 Description of 26dB & 99% Occupied Bandwidth**

This section is for reporting purpose only.

There is no restriction limits for bandwidth.

For Straddle Channel, According to KDB 789033 v01r04, If the power and PSD of the devices are uniform and comply with the lower limits specified for the U-NII-2 bands, a single measurement over the entire emission bandwidth can be performed to show compliance.

##### **3.1.2 Measuring Instruments**

The measuring equipment is listed in the section 4 of this test report.

##### **3.1.3 Test Procedures**

1. The testing follows FCC KDB 789033 D02 General UNII Test Procedures New Rules v01r04. Section C) Emission bandwidth
2. Set RBW = approximately 1% of the emission bandwidth.
3. Set the VBW > RBW.
4. Detector = Peak.
5. Trace mode = max hold
6. Measure the maximum width of the emission that is 26 dB down from the peak of the emission. Compare this with the RBW setting of the analyzer. Readjust RBW and repeat measurement as needed until the RBW/EBW ratio is approximately 1%.
7. For 99% Bandwidth Measurement, the spectrum analyzer's resolution bandwidth (RBW) is set 1MHz and set the Video bandwidth (VBW)  $\geq 3 * RBW$ .
8. Measure and record the results in the test report.

For Straddle channel across the band 5.725-5.85 GHz,

The following procedure shall be used for measuring 6dB bandwidth:

- 1) Set RBW = 100 kHz.
- 2) Set the video bandwidth (VBW)  $\geq 3 \times$  RBW.
- 3) Detector = Peak.
- 4) Trace mode = max hold.
- 5) Sweep = auto couple.
- 6) Allow the trace to stabilize.
- 7) Measure the maximum width of the emission that is constrained by the frequencies associated with the two outermost amplitude points (upper and lower frequencies) that are attenuated by 6 dB relative to the maximum level measured in the fundamental emission.

### 3.1.4 Test Setup

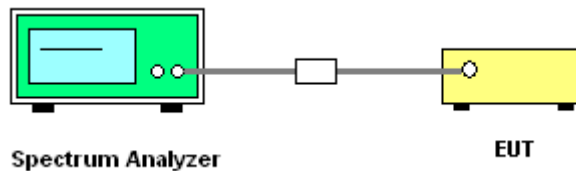

### 3.1.5 Test Result of 6dB & 26dB & 99% Occupied Bandwidth

Please refer to Appendix A.

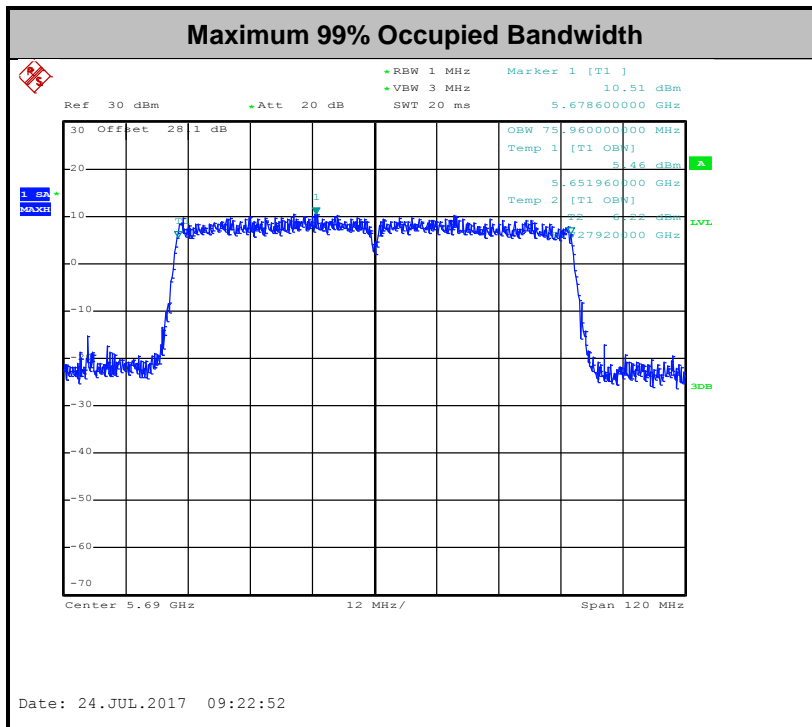
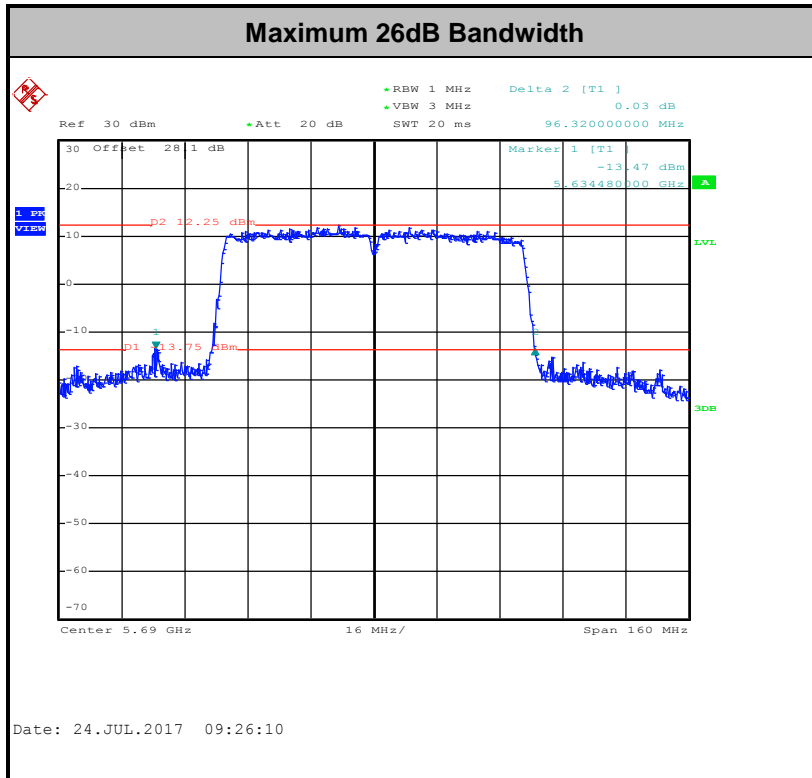

**Note:** The occupied channel bandwidth is maintained within the band of operation for all of the modulations.



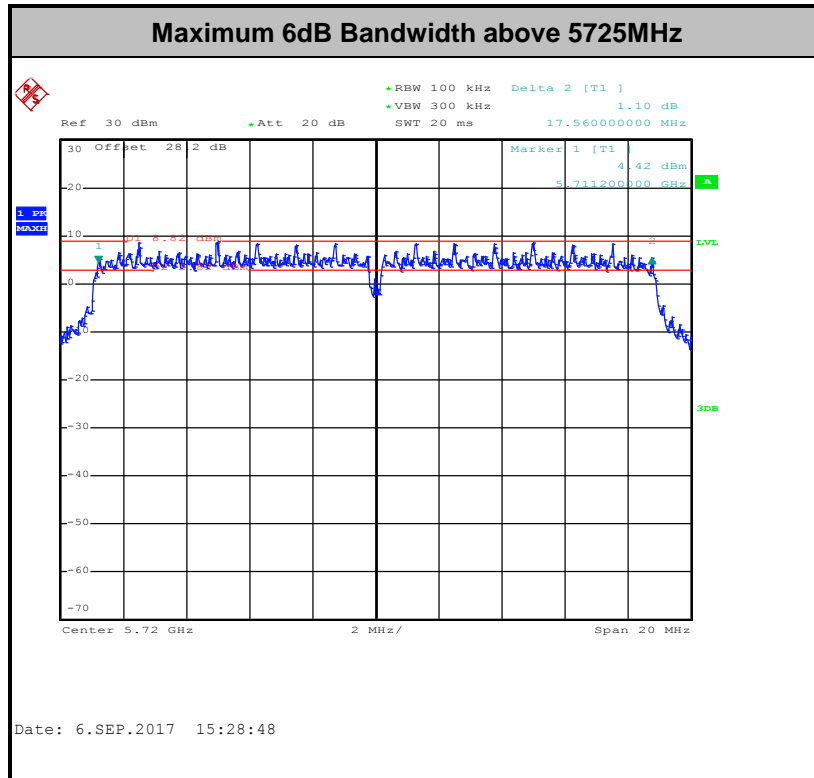

**Note:** 6 dB Bandwidth above 5725MHz is derived from the plot using formula "marker 1 + delta 2 - 5725 (MHz)". For example,  $5711.2 + 17.56 - 5725$  (MHz) = 3.76 MHz



## 3.2 Maximum Conducted Output Power Measurement

### 3.2.1 Limit of Maximum Conducted Output Power

<FCC 14-30 CFR 15.407>

For mobile and portable client devices in the 5.15–5.25 GHz band, the maximum conducted output power over the frequency band of operation shall not exceed 250 mW.

For the 5.25–5.725 GHz bands, the maximum conducted output power over the frequency bands of operation shall not exceed the lesser of 250 mW or  $11 \text{ dBm} + 10 \log B$ , where B is the 26 dB emission bandwidth in megahertz.

If transmitting antennas of directional gain greater than 6 dBi are used, the peak output power shall be reduced by the amount in dB that the directional gain of the antenna exceeds 6 dBi.

Note that U-NII-2 band, devices with a maximum e.i.r.p. greater than 500 mW shall implement TPC in order to have the capability to operate at least 6 dB below the maximum permitted e.i.r.p. of 1 W.

For Straddle Channel, According to KDB 789033 v01r04, If the power and PSD of the devices are uniform and comply with the lower limits specified for the U-NII-2 bands, a single measurement over the entire emission bandwidth can be performed to show compliance.

### 3.2.2 Measuring Instruments

The measuring equipment is listed in the section 4 of this test report.

### 3.2.3 Test Procedures

#### CDD modes

The testing follows Method PM of FCC KDB 789033 D02 General UNII Test Procedures New Rules v01r04 for CDD modes.

Method PM (Measurement using an RF average power meter):

1. Measurement is performed using a wideband RF power meter.
2. The EUT is configured to transmit continuously with a consistent duty cycle at its maximum power control level.
3. Measure the average power of the transmitter, and the average power is corrected with duty factor,  $10 \log(1/x)$ , where x is the duty cycle.

### 3.2.4 Test Setup

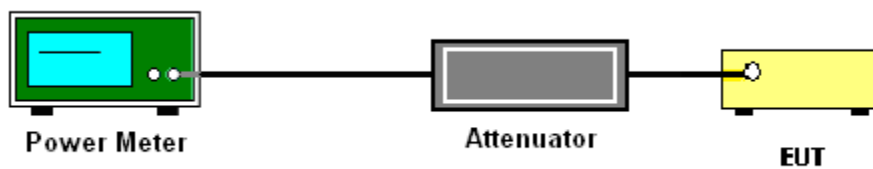



### 3.3 Power Spectral Density Measurement

#### 3.3.1 Limit of Power Spectral Density

<FCC 14-30 CFR 15.407>

For mobile and portable client devices in the 5.15–5.25 GHz band, the maximum power spectral density shall not exceed 11dBm in any 1 megahertz band.

For the 5.25–5.725 GHz bands, the maximum power spectral density shall not exceed 11 dBm in any 1 megahertz band.

If transmitting antennas of directional gain greater than 6 dBi are used, the peak output power shall be reduced by the amount in dB that the directional gain of the antenna exceeds 6 dBi.

For Straddle Channel, According to KDB 789033 v01r04, If the power and PSD of the devices are uniform and comply with the lower limits specified for the U-NII-2 bands, a single measurement over the entire emission bandwidth can be performed to show compliance.

#### 3.3.2 Measuring Instruments

The measuring equipment is listed in the section 4 of this test report.

#### 3.3.3 Test Procedures

The testing follows FCC KDB 789033 D02 General UNII Test Procedures New Rules v01r04. Section F) Maximum power spectral density.

CDD modes

**# Method SA-2 #**

(trace averaging across on and off times of the EUT transmissions, followed by duty cycle correction).

- Measure the duty cycle.
- Set span to encompass the entire emission bandwidth (EBW) of the signal.
- Set RBW = 1 MHz.
- Set VBW  $\geq$  3 MHz.
- Number of points in sweep  $\geq$  2 Span / RBW.
- Sweep time = auto.
- Detector = RMS
- Trace average at least 100 traces in power averaging mode.
- Add  $10 \log(1/x)$ , where x is the duty cycle, to the measured power in order to compute the average power during the actual transmission times. For example, add  $10 \log(1/0.25) = 6$  dB if the duty cycle is 25 percent.

1. The RF output of EUT was connected to the spectrum analyzer by a low loss cable.
2. Each plot has already offset with cable loss, and attenuator loss. Measure the PPSD and record it.
3. For MIMO mode, calculation method follows FCC KDB 662911 D01 Multiple Transmitter Output v02r01.

Method (a): Measure and sum the spectra across the outputs.

The total final Power Spectral Density is from a device with 2 transmitter outputs. The spectrum measurements of the individual outputs are all performed with the same span and number of points, the spectrum value in the first spectral bin of output 1 is summed with that in the first spectral bin of output 2 to obtain the value for the first frequency bin of the summed spectrum.

### 3.3.4 Test Setup

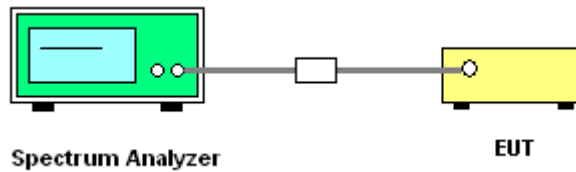

### 3.3.5 Test Result of Power Spectral Density

Please refer to Appendix A.

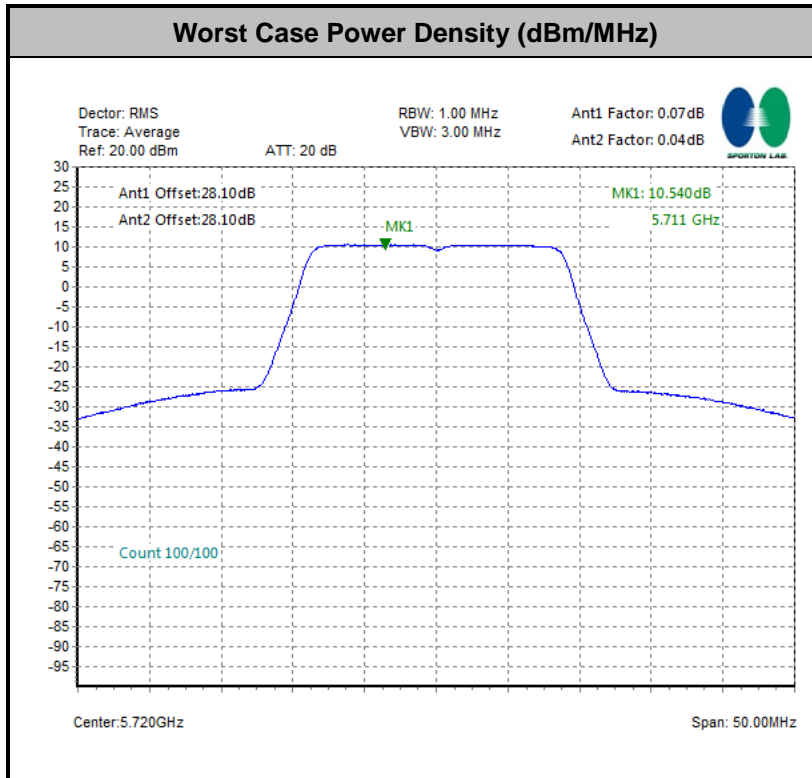

**Note:** Average Power Density (dB) = Measured value+ Duty Factor



### 3.4 Unwanted Emissions Measurement

This section is to measure unwanted emissions through radiated measurement for band edge spurious emissions and out of band emissions measurement.

#### 3.4.1 Limit of Unwanted Emissions

- (1) For transmitters operating in the 5150-5250 MHz band: all emissions outside of the 5150-5350 MHz band shall not exceed an EIRP of -27dBm/MHz.

For transmitters operating in the 5250-5350 MHz band: all emissions outside of the 5150-5350 MHz band shall not exceed an EIRP of -27 dBm/MHz. Devices operating in the 5250-5350 MHz band that generate emissions in the 5150-5250 MHz band must meet all applicable technical requirements for operation in the 5150-5250 MHz band (including indoor use) or alternatively meet an out-of-band emission EIRP limit of -27 dBm/MHz in the 5150-5250 MHz band.

For transmitters operating in the 5470-5600 MHz and 5650-5725MHz band: all emissions outside of the 5470-5600 MHz and 5650-5725MHz band shall not exceed an EIRP of -27 dBm/MHz.

- (2) Unwanted spurious emissions fallen in restricted bands shall comply with the general field strength limits as below table,

Frequency (MHz)	Field Strength (microvolts/meter)	Measurement Distance (meters)
0.009 – 0.490	2400/F(kHz)	300
0.490 – 1.705	24000/F(kHz)	30
1.705 – 30.0	30	30
30 – 88	100	3
88 – 216	150	3
216 - 960	200	3
Above 960	500	3

**Note:** The following formula is used to convert the EIRP to field strength.

$$E = \frac{1000000\sqrt{30P}}{3} \text{ } \mu\text{V/m, where P is the eirp (Watts)}$$



EIRP (dBm)	Field Strength at 3m (dBμV/m)
- 27	68.3

(3) KDB789033 D02 v01r04 G)2)c)

- (i) Sections 15.407(b)(1) to (b)(3) specify the unwanted emission limits for the U-NII-1 and U-NII-2 bands. As specified, emissions above 1000 MHz that are outside of the restricted bands are subject to a peak emission limit of -27 dBm/MHz.<sup>3</sup>
- (ii) Section 15.407(b)(4) specifies the unwanted emission limit for the U-NII-3 band. A band emissions mask is specified in Section 15.407(b)(4)(i). The emission limits are in terms of a Peak detector. An alternative to the band emissions mask is specified in Section 15.407(b)(4)(ii). The alternative limits are based on the highest antenna gain specified in the filing. There are also marketing and importation restrictions for the devices using the alternative limit.<sup>4</sup>

**Note 3:** An out-of-band emission that complies with both the average and peak limits of Section 15.209 is not required to satisfy the -27 dBm/MHz peak emission limit.

**Note 4:** Only devices with antenna gains of 10 dBi or less may be approved using the emission limits specified in Section 15.247(d) till March 2, 2018; all other devices operating in this band must use the mask specified in Section 15.407(b)(4)(i).

### 3.4.2 Measuring Instruments

The measuring equipment is listed in the section 4 of this test report.

### 3.4.3 Test Procedures

1. The testing follows FCC KDB 789033 D02 General UNII Test Procedures New Rules v01r04. Section G) Unwanted emissions measurement.
  - (1) Procedure for Unwanted Emissions Measurements Below 1000MHz
    - RBW = 120 kHz
    - VBW = 300 kHz
    - Detector = Peak
    - Trace mode = max hold





(2) Procedure for Peak Unwanted Emissions Measurements Above 1000 MHz

- RBW = 1 MHz
- VBW  $\geq$  3 MHz
- Detector = Peak
- Sweep time = auto
- Trace mode = max hold

(3) Procedures for Average Unwanted Emissions Measurements Above 1000MHz

- RBW = 1 MHz
- VBW = 10 Hz, when duty cycle is no less than 98 percent.
- VBW  $\geq$  1/T, when duty cycle is less than 98 percent where T is the minimum transmission duration over which the transmitter is on and is transmitting at its maximum power control level for the tested mode of operation.

2. The EUT was placed on a turntable with 0.8 meter for frequency below 1GHz and 1.5 meter for frequency above 1GHz respectively above ground.
3. The EUT was set 3 meters from the interference receiving antenna which was mounted on the top of a variable height antenna tower.
4. The antenna is a broadband antenna and its height is adjusted between one meter and four meters above ground to find the maximum value of the field strength for both horizontal polarization and vertical polarization of the antenna.
5. For each suspected emission, the EUT was arranged to its worst case and then adjust the antenna tower (from 1 m to 4 m) and turntable (from 0 degree to 360 degrees) to find the maximum reading.
6. For testing below 1GHz, if the emission level of the EUT in peak mode was 3 dB lower than the limit specified, then peak values of EUT will be reported, otherwise, the emissions will be repeated one by one using the CISPR quasi-peak method and reported.
7. For testing above 1GHz, the emission level of the EUT in peak mode was 20dB lower than average limit (that means the emission level in average mode also complies with the limit in average mode), then peak values of EUT will be reported, otherwise, the emissions will be measured in average mode again and reported.

### 3.4.4 Test Setup

For radiated emissions below 30MHz

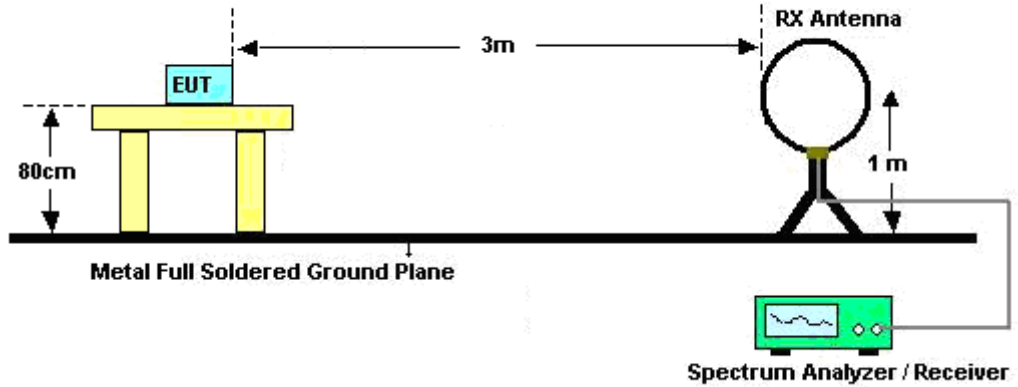

For radiated emissions from 30MHz to 1GHz

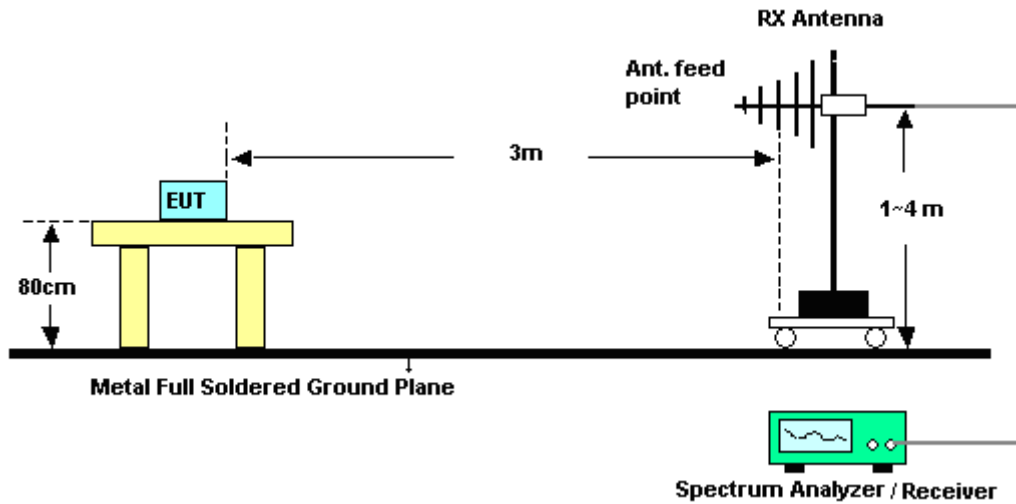

For radiated emissions above 1GHz

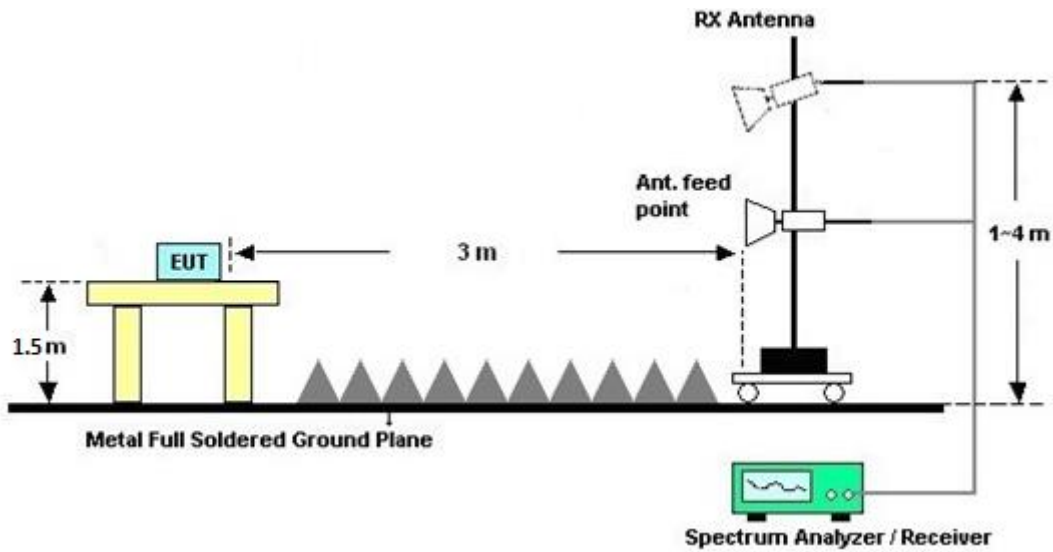

### 3.4.5 Test Results of Radiated Spurious Emissions (9 kHz ~ 30 MHz)

The low frequency, which started from 9 kHz to 30MHz, was pre-scanned and the result which was 20dB lower than the limit line was not reported.

There is a comparison data of both open-field test site and semi-Anechoic chamber, and the result came out very similar.

### 3.4.6 Test Result of Radiated Spurious at Band Edges

Please refer to Appendix C and D.

### 3.4.7 Duty Cycle

Please refer to Appendix E.

### 3.4.8 Test Result of Radiated Spurious Emissions (30MHz ~ 10th Harmonic)

Please refer to Appendix C and D.



### 3.5 AC Conducted Emission Measurement

#### 3.5.1 Limit of AC Conducted Emission

For equipment that is designed to be connected to the public utility (AC) power line, the radio frequency voltage that is conducted back onto the AC power line on any frequency or frequencies within the band 150 kHz to 30 MHz shall not exceed the limits in the following table.

Frequency of emission (MHz)	Conducted limit (dB $\mu$ V)	
	Quasi-peak	Average
0.15-0.5	66 to 56*	56 to 46*
0.5-5	56	46
5-30	60	50

\*Decreases with the logarithm of the frequency.

#### 3.5.2 Measuring Instruments

The measuring equipment is listed in the section 4 of this test report.

#### 3.5.3 Test Procedures

1. The EUT was placed 0.4 meter from the conducting wall of the shielding room was kept at least 80 centimeters from any other grounded conducting surface.
2. Connect EUT to the power mains through a line impedance stabilization network (LISN).
3. All the support units are connecting to the other LISN.
4. The LISN provides 50 ohm coupling impedance for the measuring instrument.
5. The FCC states that a 50 ohm, 50 microhenry LISN should be used.
6. Both sides of AC line were checked for maximum conducted interference.
7. The frequency range from 150 kHz to 30 MHz was searched.
8. Set the test-receiver system to Peak Detect Function and specified bandwidth with Maximum Hold Mode.

### 3.5.4 Test Setup

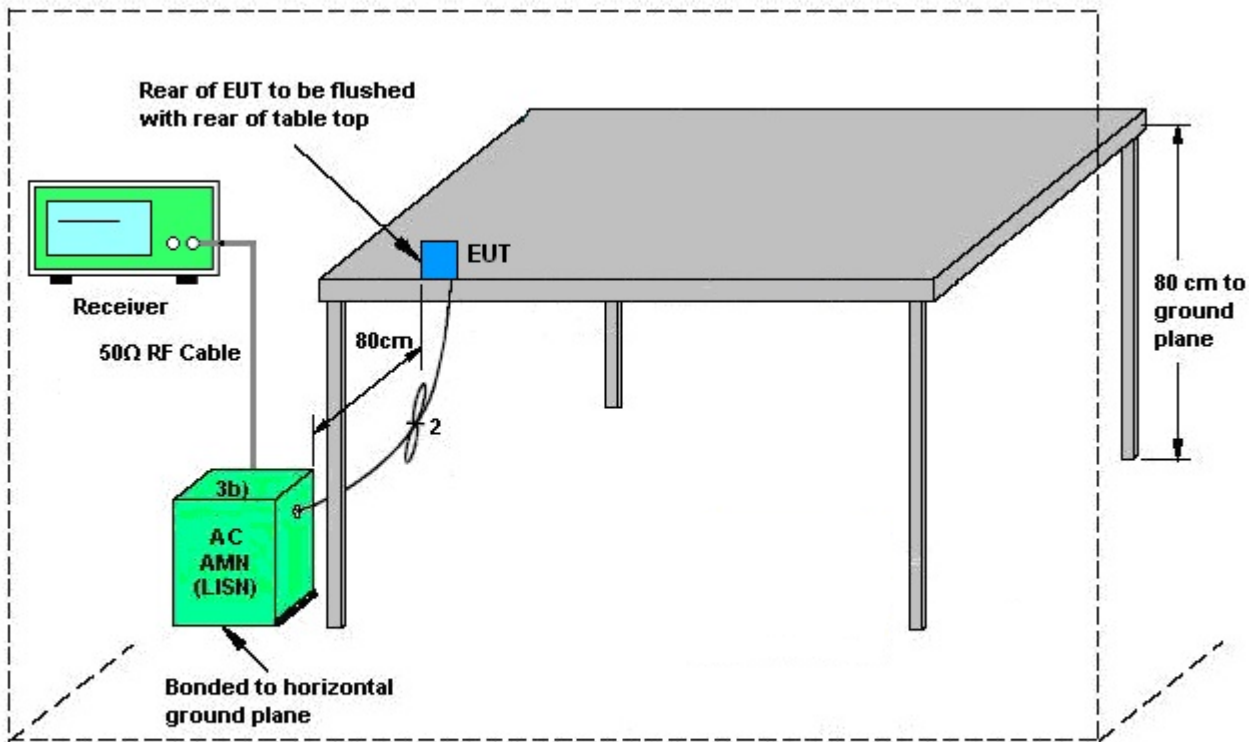

AMN = Artificial mains network (LISN)  
AE = Associated equipment  
EUT = Equipment under test  
ISN = Impedance stabilization network

### 3.5.5 Test Result of AC Conducted Emission

Please refer to Appendix B.

## 3.6 Frequency Stability Measurement

### 3.6.1 Limit of Frequency Stability

Manufacturers of U-NII devices are responsible for ensuring frequency stability such that an emission is maintained within the band of operation under all conditions of normal operation as specified in the user's manual.

### 3.6.2 Measuring Instruments

The measuring equipment is listed in the section 4 of this test report.

### 3.6.3 Test Procedures

1. To ensure emission at the band edge is maintained within the authorized band, those values shall be measured by radiation emissions at upper and lower frequency points, and finally compensated by frequency deviation as procedures below.
2. The EUT was operated at the maximum output power, and connected to the spectrum analyzer, which is set to maximum hold function and peak detector. The peak value of the power envelope was measured and noted. The upper and lower frequency points were respectively measured relatively 10dB lower than the measured peak value.
3. The frequency deviation was calculated by adding the upper frequency point and the lower frequency point divided by two. Those detailed values of frequency deviation are provided in table below.
4. Follower ANSI C63.10 : 2013 section 6.8.

### 3.6.4 Test Setup

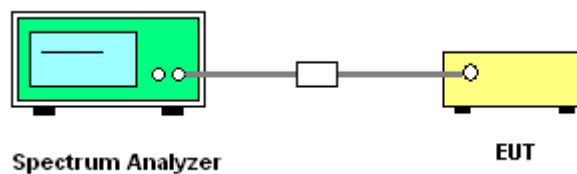

### 3.6.5 Test Result of Frequency Stability

Please refer to Appendix A.

The frequency band 5180-5240MHz which was verified by testing against other standard is less than 20 ppm which is sufficient to maintain the signal within the 5150-5250MHz band.



## **3.7 Automatically Discontinue Transmission**

### **3.7.1 Limit of Automatically Discontinue Transmission**

The device shall automatically discontinue transmission in case of either absence of information to transmit or operational failure. These provisions are not intended to preclude the transmission of control or signaling information or the use of repetitive codes used by certain digital technologies to complete frame or burst intervals. Applicants shall include in their application for equipment authorization to describe how this requirement is met.

### **3.7.2 Measuring Instruments**

The measuring equipment is listed in the section 4 of this test report.

### **3.7.3 Test Result of Automatically Discontinue Transmission**

EUT is verified this characteristic during the function check of normal sample associated with an access point:

- A. Information start: make EUT supply information to the access point.
- B. Information stop: stop supplying information to the access point.

While the EUT is not transmitting any information, the EUT can automatically discontinue transmission and become standby mode for power saving.

- C. Information start: make EUT supply information to the access point again.

The EUT can detect the controlling signal of ACK message transmitting from remote device and verify whether it shall resend or discontinue transmission.



5180MHz

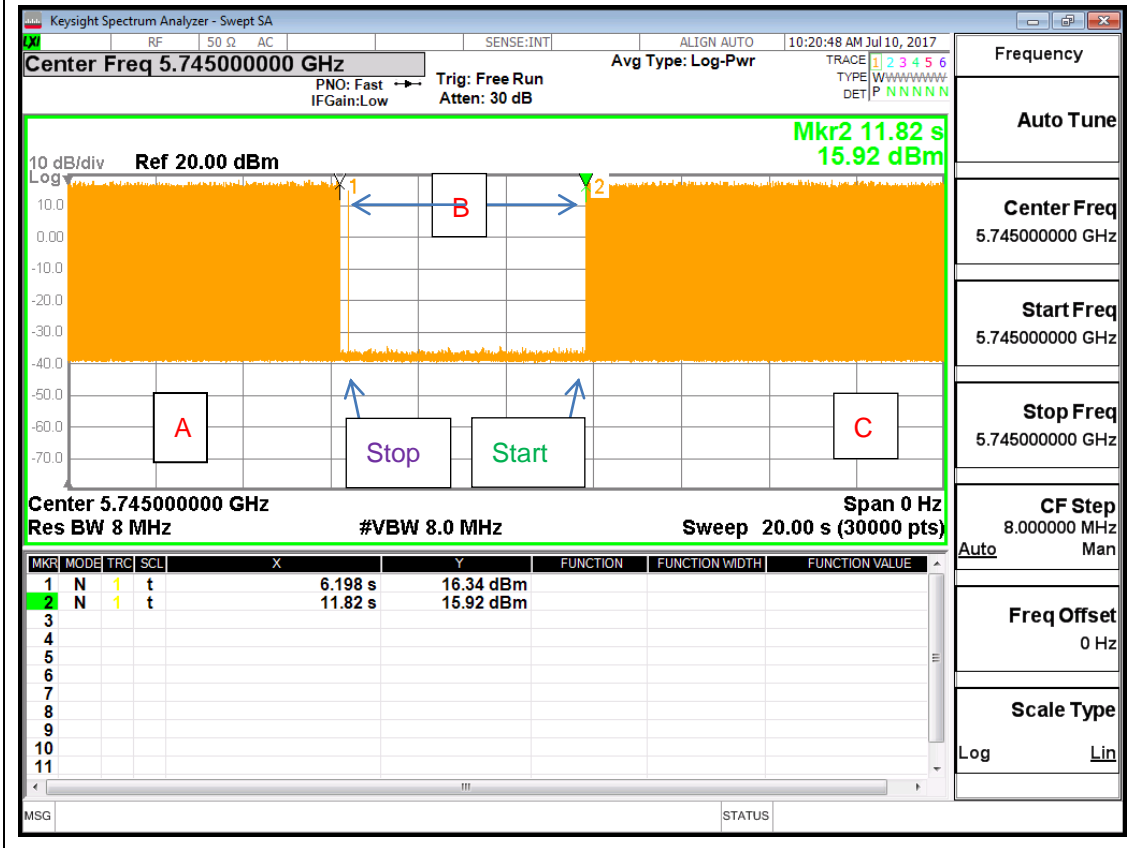

Note : The control / signalling information during the period B is precluded.





### 3.8 Antenna Requirements

#### 3.8.1 Standard Applicable

If transmitting antenna directional gain is greater than 6 dBi, both the peak transmit power and the peak power spectral density shall be reduced by the amount in dB that the directional gain of the antenna exceeds 6 dBi.

#### 3.8.2 Antenna Anti-Replacement Construction

An embedded-in antenna design is used.

#### 3.8.3 Antenna Gain

##### CDD modes

FCC KDB 662911 D01 Multiple Transmitter Output v02r01

For CDD transmissions, directional gain is calculated as

Directional gain =  $G_{ANT} + \text{Array Gain}$ , where Array Gain is as follows.

For power spectral density (PSD) measurements on all devices,

Array Gain =  $10 \log(N_{ANT}/N_{SS}=1)$  dB.

For power measurements on IEEE 802.11 devices,

Array Gain = 0 dB (i.e., no array gain) for  $N_{ANT} \leq 4$ .

Directional gain may be calculated by using the formulas applicable to equal gain antennas with  $G_{ANT}$  set equal to the gain of the antenna having the highest gain;

The EUT supports CDD mode.

For power, the directional gain  $G_{ANT}$  is set equal to the antenna having the highest gain, i.e., F)2)f)i).

For PSD, the directional gain calculation is following F)2)f)ii) of KDB 662911 D01 v02r01.

The power and PSD limit should be modified if the directional gain of EUT is over 6 dBi,

The directional gain "DG" is calculated as following table.

			DG	DG	Power	PSD
			for	for	Limit	Limit
	Ant 1	Ant 2	Power	PSD	Reduction	Reduction
	(dBi)	(dBi)	(dBi)	(dBi)	(dB)	(dB)
Band I	4.14	3.93	4.14	7.05	0.00	1.05
Band II	3.83	3.64	3.83	6.75	0.00	0.75
Band III	2.76	3.59	3.59	6.20	0.00	0.20

Power limit reduction = Composite gain – 6dBi, ( min = 0 )

PSD limit reduction = Composite gain + PSD Array gain – 6dBi, ( min = 0 )



## 4 List of Measuring Equipment

Instrument	Manufacturer	Model No.	Serial No.	Characteristics	Calibration Date	Test Date	Due Date	Remark
AC Power Source	AC POWER	AFC-500W	F104070011	50Hz~60Hz	Dec. 01, 2016	Jul. 05, 2017 ~ Sep. 06, 2017	Nov. 30, 2017	Conducted (TH05-HY)
Power Meter	Anritsu	ML2495A	0932001	N/A	Sep. 29, 2016	Jul. 05, 2017 ~ Sep. 06, 2017	Sep. 28, 2017	Conducted (TH05-HY)
Power Sensor	Anritsu	MA2411B	0846202	300MHz~40GHz	Sep. 29, 2016	Jul. 05, 2017 ~ Sep. 06, 2017	Sep. 28, 2017	Conducted (TH05-HY)
Spectrum Analyzer	Rohde & Schwarz	FSP40	100057	9kHz-40GHz	Nov. 25, 2016	Jul. 05, 2017 ~ Sep. 06, 2017	Nov. 24, 2017	Conducted (TH05-HY)
Temperature Chamber	ESPEC	SH-641	92013720	-40°C ~90°C	Sep. 01, 2016	Jul. 05, 2017 ~ Sep. 06, 2017	Aug. 31, 2017	Conducted (TH05-HY)
Temperature Chamber	ESPEC	SH-641	92013720	-40°C ~90°C	Aug. 28, 2017	Aug. 27, 2017 ~ Sep. 06, 2017	Aug. 27, 2018	Conducted (TH05-HY)
AC Power Source	ChainTek	APC-1000W	N/A	N/A	N/A	Sep. 07, 2017	N/A	Conduction (CO05-HY)
LISN	Rohde & Schwarz	ENV216	100080	9kHz~30MHz	Nov. 29, 2016	Sep. 07, 2017	Nov. 28, 2017	Conduction (CO05-HY)
EMI Test Receiver	Rohde & Schwarz	ESU26	100472	20Hz~26.5GHz	Dec. 29, 2016	Sep. 07, 2017	Dec. 28, 2017	Conduction (CO05-HY)
Spectrum Analyzer	Keysight	N9010A	MY54200486	10Hz ~ 44GHz	Oct. 12, 2016	Jul. 14, 2017 ~ Jul. 25, 2017	Oct. 11, 2017	Radiation (03CH11-HY)
EMI Test Receiver	Agilent	N9038A(MXE)	MY53290053	20Hz to 26.5GHz	Jan. 12, 2017	Jul. 14, 2017 ~ Jul. 25, 2017	Jan. 11, 2018	Radiation (03CH11-HY)
Loop Antenna	Rohde & Schwarz	HFH2-Z2	100488	9 kHz~30 MHz	Oct. 20, 2016	Jul. 14, 2017 ~ Jul. 25, 2017	Oct. 19, 2018	Radiation (03CH11-HY)
Bilog Antenna	TESEQ	CBL 6111D&N-6-06	35414&AT-N 0602	30MHz~1GHz	Oct. 15, 2016	Jul. 14, 2017 ~ Jul. 25, 2017	Oct. 14, 2017	Radiation (03CH11-HY)
Horn Antenna	SCHWARZBECK	BBHA 9120 D	9120D-1326	1GHz ~ 18GHz	Oct. 07, 2016	Jul. 14, 2017 ~ Jul. 25, 2017	Oct. 06, 2017	Radiation (03CH11-HY)
SHF-EHF Horn Antenna	SCHWARZBECK	BBHA 9170	BBHA9170584	18GHz- 40GHz	Nov. 08, 2016	Jul. 14, 2017 ~ Jul. 25, 2017	Nov. 07, 2017	Radiation (03CH11-HY)
Amplifier	SONOMA	310N	187312	9kHz~1GHz	Nov. 10, 2016	Jul. 14, 2017 ~ Jul. 25, 2017	Nov. 09, 2017	Radiation (03CH11-HY)
Preamplifier	Keysight	83017A	MY53270080	1GHz~26.5GHz	Nov. 10, 2016	Jul. 14, 2017 ~ Jul. 25, 2017	Nov. 09, 2017	Radiation (03CH11-HY)
Preamplifier	MITEQ	AMF-7D-0010 1800-30-10P	1902247	1GHz~18GHz	Jun. 23, 2017	Jul. 14, 2017 ~ Jul. 25, 2017	Jun. 22, 2018	Radiation (03CH11-HY)
Preamplifier	MITEQ	TTA1840-35-HG	1887435	18GHz~40GHz	Oct. 13, 2016	Jul. 14, 2017 ~ Jul. 25, 2017	Oct. 12, 2017	Radiation (03CH11-HY)
Antenna Mast	EMEC	AM-BS-4500-B	N/A	1~4m	N/A	Jul. 14, 2017 ~ Jul. 25, 2017	N/A	Radiation (03CH11-HY)
Turn Table	EMEC	TT 2000	N/A	0~360 Degree	N/A	Jul. 14, 2017 ~ Jul. 25, 2017	N/A	Radiation (03CH11-HY)



## 5 Uncertainty of Evaluation

### Uncertainty of Conducted Emission Measurement (150kHz ~ 30MHz)

Measuring Uncertainty for a Level of Confidence of 95% ( $U = 2Uc(y)$ )	2.70
---	------

### Uncertainty of Radiated Emission Measurement (30 MHz ~ 1000 MHz)

Measuring Uncertainty for a Level of Confidence of 95% ( $U = 2Uc(y)$ )	5.20
---	------

### Uncertainty of Radiated Emission Measurement (1000 MHz ~ 18000 MHz)

Measuring Uncertainty for a Level of Confidence of 95% ( $U = 2Uc(y)$ )	5.50
---	------

### Uncertainty of Radiated Emission Measurement (18000 MHz ~ 40000 MHz)

Measuring Uncertainty for a Level of Confidence of 95% ( $U = 2Uc(y)$ )	5.20
---	------

**Appendix A. Test Result of Conducted Test Items**

Test Engineer:	Tommy Lee / Derek Hsu/ Aking chang	Temperature:	21~25	°C
Test Date:	2017/7/5~2017/09/06	Relative Humidity:	51~54	%

**TEST RESULTS DATA**  
**26dB and 99% OBW**

Band I													
Mod.	Data Rate	NTX	CH.	Freq. (MHz)	99% Bandwidth (MHz)		26 dB Bandwidth (MHz)		IC 99% Bandwidth Power Limit (dBm)		IC 99% Bandwidth EIRP Limit (dBm)		Note
					Ant 1	Ant 2	Ant 1	Ant 2	Ant 1	Ant 2	Ant 1	Ant 2	
11a	6Mbps	2	36	5180	18.20	18.05	22.90	22.60	-	-	22.56	-	
11a	6Mbps	2	44	5220	18.05	18.25	22.90	22.70	-	-	22.56	-	
11a	6Mbps	2	48	5240	17.20	17.15	20.70	20.30	-	-	22.34	-	
HT20	MCS0	2	36	5180	18.95	18.95	23.30	23.00	-	-	22.78	-	
HT20	MCS0	2	44	5220	18.95	18.85	23.30	23.00	-	-	22.75	-	
HT20	MCS0	2	48	5240	18.00	18.05	20.90	20.70	-	-	22.55	-	
HT40	MCS0	2	38	5190	36.70	36.60	41.22	41.04	-	-	23.01	-	
HT40	MCS0	2	46	5230	36.60	36.70	41.40	41.04	-	-	23.01	-	
VHT20	MCS0	2	36	5180	18.95	18.95	23.30	23.00	-	-	22.78	-	
VHT20	MCS0	2	44	5220	18.95	18.85	23.30	23.00	-	-	22.75	-	
VHT40	MCS0	2	38	5190	36.70	36.60	41.22	41.04	-	-	23.01	-	
VHT40	MCS0	2	46	5230	36.60	36.70	41.40	41.04	-	-	23.01	-	
VHT80	MCS0	2	42	5210	75.84	75.84	82.24	81.92	-	-	23.01	-	

**TEST RESULTS DATA**  
**Average Power Table**

FCC Band I														
Mod.	Data Rate	NTX	CH.	Freq. (MHz)	Duty Factor (dB)		Average Conducted Power (dBm)			FCC Conducted Power Limit (dBm)		DG (dBi)		Pass/Fail
					Ant 1	Ant 2	Ant 1	Ant 2	SUM	Ant 1	Ant 2	Ant 1	Ant 2	
11a	6Mbps	1	36	5180	0.04	0.04	18.57	18.29		24.00	24.00	4.14	3.93	Pass
11a	6Mbps	1	44	5220	0.04	0.04	18.22	18.18		24.00	24.00	4.14	3.93	Pass
11a	6Mbps	1	48	5240	0.04	0.04	18.15	18.24		24.00	24.00	4.14	3.93	Pass
HT20	MCS0	1	36	5180	0.07	0.07	19.04	18.62		24.00	24.00	4.14	3.93	Pass
HT20	MCS0	1	44	5220	0.07	0.07	18.76	18.71		24.00	24.00	4.14	3.93	Pass
HT20	MCS0	1	48	5240	0.07	0.07	18.62	18.52		24.00	24.00	4.14	3.93	Pass
HT40	MCS0	1	38	5190	0.08	0.08	17.48	17.35		24.00	24.00	4.14	3.93	Pass
HT40	MCS0	1	46	5230	0.08	0.08	20.79	20.83		24.00	24.00	4.14	3.93	Pass
VHT20	MCS0	1	36	5180	0.04	0.04	18.91	18.54		24.00	24.00	4.14	3.93	Pass
VHT20	MCS0	1	44	5220	0.04	0.04	18.70	18.67		24.00	24.00	4.14	3.93	Pass
VHT20	MCS0	1	48	5240	0.04	0.04	18.57	18.49		24.00	24.00	4.14	3.93	Pass
VHT40	MCS0	1	38	5190	0.08	0.08	17.47	17.33		24.00	24.00	4.14	3.93	Pass
VHT40	MCS0	1	46	5230	0.08	0.08	20.72	20.64		24.00	24.00	4.14	3.93	Pass
VHT80	MCS0	1	42	5210	0.08	0.08	17.80	17.88		24.00	24.00	4.14	3.93	Pass
11a	6Mbps	2	36	5180	0.04	0.05	18.80	18.33	21.58	24.00		4.14		Pass
11a	6Mbps	2	44	5220	0.04	0.05	18.48	18.22	21.36	24.00		4.14		Pass
11a	6Mbps	2	48	5240	0.04	0.05	18.54	18.27	21.42	24.00		4.14		Pass
HT20	MCS0	2	36	5180	0.07	0.04	19.36	18.69	22.05	24.00		4.14		Pass
HT20	MCS0	2	44	5220	0.07	0.04	18.93	18.74	21.85	24.00		4.14		Pass
HT20	MCS0	2	48	5240	0.07	0.04	18.87	18.58	21.74	24.00		4.14		Pass
HT40	MCS0	2	38	5190	0.08	0.08	17.95	17.38	20.68	24.00		4.14		Pass
HT40	MCS0	2	46	5230	0.08	0.08	20.92	20.97	23.95	24.00		4.14		Pass
VHT20	MCS0	2	36	5180	0.04	0.04	19.21	18.54	21.90	24.00		4.14		Pass
VHT20	MCS0	2	44	5220	0.04	0.04	18.94	18.70	21.84	24.00		4.14		Pass
VHT20	MCS0	2	48	5240	0.04	0.04	18.81	18.52	21.68	24.00		4.14		Pass
VHT40	MCS0	2	38	5190	0.08	0.08	17.93	17.35	20.66	24.00		4.14		Pass
VHT40	MCS0	2	46	5230	0.08	0.08	20.92	20.66	23.80	24.00		4.14		Pass
VHT80	MCS0	2	42	5210	0.08	0.08	18.22	17.93	21.09	24.00		4.14		Pass

**TEST RESULTS DATA**  
**Power Spectral Density**

FCC Band I														
Mod.	Data Rate	NTX	CH.	Freq. (MHz)	Duty Factor (dB)		Average Power Density (dBm/MHz)			Average PSD Limit (dBm/MHz)		DG (dBi)		Pass /Fail
					Ant 1	Ant 2	Ant 1	Ant 2	SUM	Ant 1	Ant 2	Ant 1	Ant 2	
11a	6Mbps	2	36	5180	0.04	0.05			9.53	9.95	7.05		Pass	
11a	6Mbps	2	44	5220	0.04	0.05			9.54	9.95	7.05		Pass	
11a	6Mbps	2	48	5240	0.04	0.05			9.64	9.95	7.05		Pass	
HT20	MCS0	2	36	5180	0.07	0.04			9.66	9.95	7.05		Pass	
HT20	MCS0	2	44	5220	0.07	0.04			9.62	9.95	7.05		Pass	
HT20	MCS0	2	48	5240	0.07	0.04			9.66	9.95	7.05		Pass	
HT40	MCS0	2	38	5190	0.08	0.08			5.31	9.95	7.05		Pass	
HT40	MCS0	2	46	5230	0.08	0.08			8.74	9.95	7.05		Pass	
VHT20	MCS0	2	36	5180	0.04	0.04			9.59	9.95	7.05		Pass	
VHT20	MCS0	2	44	5220	0.04	0.04			9.53	9.95	7.05		Pass	
VHT20	MCS0	2	48	5240	0.04	0.04			9.54	9.95	7.05		Pass	
VHT40	MCS0	2	38	5190	0.08	0.08			5.28	9.95	7.05		Pass	
VHT40	MCS0	2	46	5230	0.08	0.08			8.58	9.95	7.05		Pass	
VHT80	MCS0	2	42	5210	0.08	0.08			3.04	9.95	7.05		Pass	

**TEST RESULTS DATA**  
**26dB and 99% OBW**

Band II															
Mod.	Data Rate	NTX	CH.	Freq. (MHz)	99% Bandwidth (MHz)		26 dB Bandwidth (MHz)		IC 99% Bandwidth Power Limit (dBm)		IC 99% Bandwidth EIRP Limit (dBm)		FCC 26dB Bandwidth Power Limit (dBm)		Note
					Ant 1	Ant 2	Ant 1	Ant 2	Ant 1	Ant 2	Ant 1	Ant 2	Ant 1	Ant 2	
11a	6Mbps	2	52	5260	17.20	17.25	20.50	20.30	23.36		29.36		23.98		
11a	6Mbps	2	60	5300	17.95	18.25	22.90	22.90	23.54		29.54		23.98		
11a	6Mbps	2	64	5320	18.25	18.10	23.00	22.60	23.58		29.58		23.98		
HT20	MCS0	2	52	5260	18.00	18.00	20.90	20.60	23.55		29.55		23.98		
HT20	MCS0	2	60	5300	19.00	18.95	23.30	23.00	23.78		29.78		23.98		
HT20	MCS0	2	64	5320	19.15	18.95	23.20	23.10	23.78		29.78		23.98		
HT40	MCS0	2	54	5270	36.70	36.80	41.58	41.04	23.98		30.00		23.98		
HT40	MCS0	2	62	5310	36.60	36.70	41.40	41.04	23.98		30.00		23.98		
VHT20	MCS0	2	52	5260	18.00	18.00	20.90	20.60	23.55		29.55		23.98		
VHT20	MCS0	2	60	5300	19.00	18.95	23.30	23.00	23.78		29.78		23.98		
VHT20	MCS0	2	64	5320	19.15	18.95	23.20	23.10	23.78		29.78		23.98		
VHT40	MCS0	2	54	5270	36.70	36.80	41.58	41.04	23.98		30.00		23.98		
VHT40	MCS0	2	62	5310	36.60	36.70	41.40	41.04	23.98		30.00		23.98		
VHT80	MCS0	2	58	5290	75.96	75.84	82.24	81.92	23.98		30.00		23.98		



**TEST RESULTS DATA**  
**Average Power Table**

FCC Band II															
Mod.	Data Rate	NTX	CH.	Freq. (MHz)	Duty Factor (dB)		Average Conducted Power (dBm)			FCC Conducted Power Limit (dBm)		DG (dBi)		EIRP Power Limit (dBm)	Pass/Fail
					Ant 1	Ant 2	Ant 1	Ant 2	SUM	Ant 1	Ant 2	Ant 1	Ant 2		
11a	6Mbps	1	52	5260	0.04	0.04	18.24	18.14		23.98	23.98	3.83	3.64	30	Pass
11a	6Mbps	1	60	5300	0.04	0.04	18.84	18.54		23.98	23.98	3.83	3.64	30	Pass
11a	6Mbps	1	64	5320	0.04	0.04	18.92	18.53		23.98	23.98	3.83	3.64	30	Pass
HT20	MCS0	1	52	5260	0.07	0.07	18.70	18.37		23.98	23.98	3.83	3.64	30	Pass
HT20	MCS0	1	60	5300	0.07	0.07	19.11	18.72		23.98	23.98	3.83	3.64	30	Pass
HT20	MCS0	1	64	5320	0.07	0.07	18.62	18.46		23.98	23.98	3.83	3.64	30	Pass
HT40	MCS0	1	54	5270	0.08	0.08	20.88	20.60		23.98	23.98	3.83	3.64	30	Pass
HT40	MCS0	1	62	5310	0.08	0.08	17.88	18.08		23.98	23.98	3.83	3.64	30	Pass
VHT20	MCS0	1	52	5260	0.04	0.04	18.65	18.34		23.98	23.98	3.83	3.64	30	Pass
VHT20	MCS0	1	60	5300	0.04	0.04	19.05	18.69		23.98	23.98	3.83	3.64	30	Pass
VHT20	MCS0	1	64	5320	0.04	0.04	18.57	18.44		23.98	23.98	3.83	3.64	30	Pass
VHT40	MCS0	1	54	5270	0.08	0.08	20.78	20.55		23.98	23.98	3.83	3.64	30	Pass
VHT40	MCS0	1	62	5310	0.08	0.08	17.83	17.98		23.98	23.98	3.83	3.64	30	Pass
VHT80	MCS0	1	58	5290	0.08	0.08	18.20	17.86		23.98	23.98	3.83	3.64	30	Pass
11a	6Mbps	2	52	5260	0.04	0.05	18.79	18.19	21.51	23.98		3.83		30	Pass
11a	6Mbps	2	60	5300	0.04	0.05	19.31	18.60	21.98	23.98		3.83		30	Pass
11a	6Mbps	2	64	5320	0.04	0.05	19.37	18.61	22.02	23.98		3.83		30	Pass
HT20	MCS0	2	52	5260	0.07	0.04	19.16	18.44	21.83	23.98		3.83		30	Pass
HT20	MCS0	2	60	5300	0.07	0.04	19.47	18.74	22.13	23.98		3.83		30	Pass
HT20	MCS0	2	64	5320	0.07	0.04	19.22	18.47	21.87	23.98		3.83		30	Pass
HT40	MCS0	2	54	5270	0.08	0.08	21.20	20.63	23.93	23.98		3.83		30	Pass
HT40	MCS0	2	62	5310	0.08	0.08	18.18	18.14	21.17	23.98		3.83		30	Pass
VHT20	MCS0	2	52	5260	0.04	0.04	19.18	18.39	21.82	23.98		3.83		30	Pass
VHT20	MCS0	2	60	5300	0.04	0.04	19.49	18.69	22.12	23.98		3.83		30	Pass
VHT20	MCS0	2	64	5320	0.04	0.04	19.22	18.44	21.86	23.98		3.83		30	Pass
VHT40	MCS0	2	54	5270	0.08	0.08	21.01	20.58	23.81	23.98		3.83		30	Pass
VHT40	MCS0	2	62	5310	0.08	0.08	18.13	18.10	21.12	23.98		3.83		30	Pass
VHT80	MCS0	2	58	5290	0.08	0.08	18.49	17.90	21.22	23.98		3.83		30	Pass

**TEST RESULTS DATA**  
**Power Spectral Density**

Band II														
Mod.	Data Rate	NTX	CH.	Freq. (MHz)	Duty Factor (dB)		Average Power Density (dBm/MHz)			Average PSD Limit (dBm/MHz)		DG (dBi)		Pass /Fail
					Ant 1	Ant 2	Ant 1	Ant 2	SUM	Ant 1	Ant 2	Ant 1	Ant 2	
11a	6Mbps	2	52	5260	0.04	0.05			9.85	10.25	6.75		Pass	
11a	6Mbps	2	60	5300	0.04	0.05			10.12	10.25	6.75		Pass	
11a	6Mbps	2	64	5320	0.04	0.05			10.20	10.25	6.75		Pass	
HT20	MCS0	2	52	5260	0.07	0.04			9.80	10.25	6.75		Pass	
HT20	MCS0	2	60	5300	0.07	0.04			9.85	10.25	6.75		Pass	
HT20	MCS0	2	64	5320	0.07	0.04			9.75	10.25	6.75		Pass	
HT40	MCS0	2	54	5270	0.08	0.08			8.68	10.25	6.75		Pass	
HT40	MCS0	2	62	5310	0.08	0.08			6.03	10.25	6.75		Pass	
VHT20	MCS0	2	52	5260	0.04	0.04			9.54	10.25	6.75		Pass	
VHT20	MCS0	2	60	5300	0.04	0.04			9.52	10.25	6.75		Pass	
VHT20	MCS0	2	64	5320	0.04	0.04			9.42	10.25	6.75		Pass	
VHT40	MCS0	2	54	5270	0.08	0.08			8.22	10.25	6.75		Pass	
VHT40	MCS0	2	62	5310	0.08	0.08			5.73	10.25	6.75		Pass	
VHT80	MCS0	2	58	5290	0.08	0.08			3.07	10.25	6.75		Pass	

**TEST RESULTS DATA**  
**26dB and 99% OBW**

Band III																	
Mod.	Data Rate	NTX	CH.	Freq. (MHz)	99% Bandwidth (MHz)		26 dB Bandwidth (MHz)		6 dB Bandwidth above 5725MHz (MHz)		IC 99% Bandwidth Power Limit (dBm)		IC 99% Bandwidth EIRP Limit (dBm)		FCC 26dB Bandwidth Power Limit (dBm)		Note
					Ant 1	Ant 2	Ant 1	Ant 2	Ant 1	Ant 2	Ant 1	Ant 2	Ant 1	Ant 2	Ant 1	Ant 2	
11a	6Mbps	2	100	5500	18.25	18.00	23.20	22.40	-	-	23.55	29.55	23.98				
11a	6Mbps	2	116	5580	17.15	17.15	20.40	20.60	-	-	23.34	29.34	23.98				
11a	6Mbps	2	140	5700	18.45	18.00	23.10	22.70	-	-	23.55	29.55	23.98				
11a	6Mbps	2	144	5720	18.30	18.15	23.00	22.70	3.16	3.16	23.59	29.59	23.98				
HT20	MCS0	2	100	5500	18.95	18.90	23.10	23.00	-	-	23.76	29.76	23.98				
HT20	MCS0	2	116	5580	18.05	18.05	20.70	20.60	-	-	23.56	29.56	23.98				
HT20	MCS0	2	140	5700	18.95	18.85	23.20	23.10	-	-	23.75	29.75	23.98				
HT20	MCS0	2	144	5720	18.90	19.05	23.20	22.90	3.76	3.76	23.76	29.76	23.98				
HT40	MCS0	2	102	5510	36.70	36.60	41.58	40.86	-	-	23.98	30.00	23.98				
HT40	MCS0	2	110	5550	36.70	36.80	41.58	41.22	-	-	23.98	30.00	23.98				
HT40	MCS0	2	134	5670	36.90	36.80	41.40	41.22	-	-	23.98	30.00	23.98				
HT40	MCS0	2	142	5710	36.70	36.80	41.58	41.22	3.16	3.16	23.98	30.00	23.98				
VHT80	MCS0	2	106	5530	75.96	75.84	81.92	81.92	-	-	23.98	30.00	23.98				
VHT80	MCS0	2	122	5610	75.96	75.96	81.92	81.92	-	-	23.98	30.00	23.98				
VHT80	MCS0	2	138	5690	75.96	75.96	82.56	96.32	2.92	2.92	23.98	30.00	23.98				

Note: 6 dB Bandwidth above 5725MHz (MHz) is derived from the plot using formula "marker 1 + delta 2 - 5725 (MHz)".

**TEST RESULTS DATA**  
**Average Power Table**

FCC Band III															
Mod.	Data Rate	NTX	CH.	Freq. (MHz)	Duty Factor (dB)		Average Conducted Power (dBm)			FCC Conducted Power Limit (dBm)		DG (dBi)		EIRP Power Limit (dBm)	Pass/Fail
					Ant 1	Ant 2	Ant 1	Ant 2	SUM	Ant 1	Ant 2	Ant 1	Ant 2		
11a	6Mbps	1	100	5500	0.04	0.04	18.21	18.19		23.98	23.98	2.76	3.59	30	Pass
11a	6Mbps	1	116	5580	0.04	0.04	18.10	18.10		23.98	23.98	2.76	3.59	30	Pass
11a	6Mbps	1	140	5700	0.04	0.04	19.33	19.21		23.98	23.98	2.76	3.59	30	Pass
11a	6Mbps	1	144	5720	0.04	0.04	19.04	18.92		23.98	23.98	2.76	3.59	30	Pass
HT20	MCS0	1	100	5500	0.07	0.07	18.43	18.42		23.98	23.98	2.76	3.59	30	Pass
HT20	MCS0	1	116	5580	0.07	0.07	18.47	18.52		23.98	23.98	2.76	3.59	30	Pass
HT20	MCS0	1	140	5700	0.07	0.07	19.29	19.17		23.98	23.98	2.76	3.59	30	Pass
HT20	MCS0	1	144	5720	0.07	0.07	20.04	19.77		23.98	23.98	2.76	3.59	30	Pass
HT40	MCS0	1	102	5510	0.08	0.08	18.68	18.83		23.98	23.98	2.76	3.59	30	Pass
HT40	MCS0	1	110	5550	0.08	0.08	20.73	20.93		23.98	23.98	2.76	3.59	30	Pass
HT40	MCS0	1	134	5670	0.08	0.08	20.59	20.88		23.98	23.98	2.76	3.59	30	Pass
HT40	MCS0	1	142	5710	0.08	0.08	20.40	20.83		23.98	23.98	2.76	3.59	30	Pass
VHT20	MCS0	1	100	5500	0.04	0.04	18.39	18.38		23.98	23.98	2.76	3.59	30	Pass
VHT20	MCS0	1	116	5580	0.04	0.04	18.42	18.49		23.98	23.98	2.76	3.59	30	Pass
VHT20	MCS0	1	140	5700	0.04	0.04	19.25	18.94		23.98	23.98	2.76	3.59	30	Pass
VHT20	MCS0	1	144	5720	0.04	0.04	19.99	19.73		23.98	23.98	2.76	3.59	30	Pass
VHT40	MCS0	1	102	5510	0.08	0.08	18.63	18.48		23.98	23.98	2.76	3.59	30	Pass
VHT40	MCS0	1	110	5550	0.08	0.08	20.50	20.91		23.98	23.98	2.76	3.59	30	Pass
VHT40	MCS0	1	134	5670	0.08	0.08	20.53	20.83		23.98	23.98	2.76	3.59	30	Pass
VHT40	MCS0	1	142	5710	0.08	0.08	20.39	20.78		23.98	23.98	2.76	3.59	30	Pass
VHT80	MCS0	1	106	5530	0.08	0.08	17.78	17.83		23.98	23.98	2.76	3.59	30	Pass
VHT80	MCS0	1	122	5610	0.08	0.08	20.46	20.63		23.98	23.98	2.76	3.59	30	Pass
VHT80	MCS0	1	138	5690	0.08	0.08	20.50	20.83		23.98	23.98	2.76	3.59	30	Pass
11a	6Mbps	2	100	5500	0.04	0.05	18.35	18.23	21.30	23.98		3.59		30	Pass
11a	6Mbps	2	116	5580	0.04	0.05	18.40	18.22	21.32	23.98		3.59		30	Pass
11a	6Mbps	2	140	5700	0.04	0.05	19.34	19.33	22.35	23.98		3.59		30	Pass
11a	6Mbps	2	144	5720	0.04	0.05	19.29	19.25	22.28	23.98		3.59		30	Pass
HT20	MCS0	2	100	5500	0.07	0.04	18.85	18.69	21.78	23.98		3.59		30	Pass
HT20	MCS0	2	116	5580	0.07	0.04	18.83	18.54	21.70	23.98		3.59		30	Pass
HT20	MCS0	2	140	5700	0.07	0.04	19.35	19.43	22.40	23.98		3.59		30	Pass
HT20	MCS0	2	144	5720	0.07	0.04	20.07	20.11	23.10	23.98		3.59		30	Pass
HT40	MCS0	2	102	5510	0.08	0.08	18.73	18.98	21.86	23.98		3.59		30	Pass
HT40	MCS0	2	110	5550	0.08	0.08	20.74	21.13	23.95	23.98		3.59		30	Pass
HT40	MCS0	2	134	5670	0.08	0.08	20.77	21.12	23.96	23.98		3.59		30	Pass
HT40	MCS0	2	142	5710	0.08	0.08	20.66	21.03	23.86	23.98		3.59		30	Pass
VHT20	MCS0	2	100	5500	0.04	0.04	18.84	18.62	21.75	23.98		3.59		30	Pass
VHT20	MCS0	2	116	5580	0.04	0.04	18.76	18.59	21.69	23.98		3.59		30	Pass
VHT20	MCS0	2	140	5700	0.04	0.04	19.32	19.43	22.39	23.98		3.59		30	Pass
VHT20	MCS0	2	144	5720	0.04	0.04	20.11	20.05	23.09	23.98		3.59		30	Pass
VHT40	MCS0	2	102	5510	0.08	0.08	18.68	18.94	21.82	23.98		3.59		30	Pass
VHT40	MCS0	2	110	5550	0.08	0.08	20.70	21.14	23.93	23.98		3.59		30	Pass
VHT40	MCS0	2	134	5670	0.08	0.08	20.71	21.14	23.94	23.98		3.59		30	Pass
VHT40	MCS0	2	142	5710	0.08	0.08	20.59	20.97	23.79	23.98		3.59		30	Pass
VHT80	MCS0	2	106	5530	0.08	0.08	17.83	18.17	21.02	23.98		3.59		30	Pass
VHT80	MCS0	2	122	5610	0.08	0.08	20.52	20.88	23.72	23.98		3.59		30	Pass
VHT80	MCS0	2	138	5690	0.08	0.08	20.64	21.06	23.87	23.98		3.59		30	Pass

**TEST RESULTS DATA**  
**Power Spectral Density**

Band III														
Mod.	Data Rate	NTX	CH.	Freq. (MHz)	Duty Factor (dB)		Average Power Density (dBm/MHz)			Average PSD Limit (dBm/MHz)		DG (dBi)		Pass /Fail
					Ant 1	Ant 2	Ant 1	Ant 2	SUM	Ant 1	Ant 2	Ant 1	Ant 2	
11a	6Mbps	2	100	5500	0.04	0.05			10.38	10.80	6.20		Pass	
11a	6Mbps	2	116	5580	0.04	0.05			10.53	10.80	6.20		Pass	
11a	6Mbps	2	140	5700	0.04	0.05			10.37	10.80	6.20		Pass	
11a	6Mbps	2	144	5720	0.04	0.05			10.19	10.80	6.20		Pass	
HT20	MCS0	2	100	5500	0.07	0.04			10.46	10.80	6.20		Pass	
HT20	MCS0	2	116	5580	0.07	0.04			10.45	10.80	6.20		Pass	
HT20	MCS0	2	140	5700	0.07	0.04			9.93	10.80	6.20		Pass	
HT20	MCS0	2	144	5720	0.07	0.04			10.54	10.80	6.20		Pass	
HT40	MCS0	2	102	5510	0.08	0.08			7.69	10.80	6.20		Pass	
HT40	MCS0	2	110	5550	0.08	0.08			9.58	10.80	6.20		Pass	
HT40	MCS0	2	134	5670	0.08	0.08			8.21	10.80	6.20		Pass	
HT40	MCS0	2	142	5710	0.08	0.08			8.25	10.80	6.20		Pass	
VHT20	MCS0	2	100	5500	0.04	0.04			10.18	10.80	6.20		Pass	
VHT20	MCS0	2	116	5580	0.04	0.04			10.42	10.80	6.20		Pass	
VHT20	MCS0	2	140	5700	0.04	0.04			9.89	10.80	6.20		Pass	
VHT20	MCS0	2	144	5720	0.04	0.04			10.51	10.80	6.20		Pass	
VHT40	MCS0	2	102	5510	0.08	0.08			7.31	10.80	6.20		Pass	
VHT40	MCS0	2	110	5550	0.08	0.08			9.23	10.80	6.20		Pass	
VHT40	MCS0	2	134	5670	0.08	0.08			7.92	10.80	6.20		Pass	
VHT40	MCS0	2	142	5710	0.08	0.08			8.06	10.80	6.20		Pass	
VHT80	MCS0	2	106	5530	0.08	0.08			4.11	10.80	6.20		Pass	
VHT80	MCS0	2	122	5610	0.08	0.08			5.72	10.80	6.20		Pass	
VHT80	MCS0	2	138	5690	0.08	0.08			5.43	10.80	6.20		Pass	

**TEST RESULTS DATA**  
**Frequency Stability**

Band I										
Mod.	Data Rate	NTX	CH.	Freq. (MHz)	Center Frequency (MHz)	Frequency Deviation (MHz)	Frequency Stability (ppm)	Temperature (°C)	Voltage (V)	Note
11a	6Mbps	1	36	5180	5180.000	0.000	0.00	45	120	0 min
11a	6Mbps	1	36	5180	5180.050	0.050	9.65	-40	120	0 min
11a	6Mbps	1	36	5180	5180.000	0.000	0.00	20	132	0 min
11a	6Mbps	1	36	5180	5180.000	0.000	0.00	20	108	0 min
11a	6Mbps	1	36	5180	5180.000	0.000	0.00	20	120	0 min
11a	6Mbps	1	36	5180	5180.000	0.000	0.00	45	120	2 min
11a	6Mbps	1	36	5180	5180.050	0.050	9.65	-40	120	2 min
11a	6Mbps	1	36	5180	5180.000	0.000	0.00	20	132	2 min
11a	6Mbps	1	36	5180	5180.000	0.000	0.00	20	108	2 min
11a	6Mbps	1	36	5180	5180.000	0.000	0.00	20	120	2 min
11a	6Mbps	1	36	5180	5180.050	0.050	9.65	45	120	5 min
11a	6Mbps	1	36	5180	5180.000	0.000	0.00	-40	120	5 min
11a	6Mbps	1	36	5180	5180.000	0.000	0.00	20	132	5 min
11a	6Mbps	1	36	5180	5180.000	0.000	0.00	20	108	5 min
11a	6Mbps	1	36	5180	5180.000	0.000	0.00	20	120	5 min
11a	6Mbps	1	36	5180	5180.050	0.050	9.65	45	120	10 min
11a	6Mbps	1	36	5180	5180.000	0.000	0.00	-40	120	10 min
11a	6Mbps	1	36	5180	5180.025	0.025	4.83	20	132	10 min
11a	6Mbps	1	36	5180	5180.000	0.000	0.00	20	108	10 min
11a	6Mbps	1	36	5180	5180.000	0.000	0.00	20	120	10 min

Band II										
Mod.	Data Rate	NTX	CH.	Freq. (MHz)	Center Frequency (MHz)	Frequency Deviation (MHz)	Frequency Stability (ppm)	Temperature (°C)	Voltage (V)	Note
11a	6Mbps	1	64	5320	5320.000	0.000	0.00	45	120	0 min
11a	6Mbps	1	64	5320	5320.050	0.050	9.40	-40	120	0 min
11a	6Mbps	1	64	5320	5320.000	0.000	0.00	20	132	0 min
11a	6Mbps	1	64	5320	5320.000	0.000	0.00	20	108	0 min
11a	6Mbps	1	64	5320	5320.000	0.000	0.00	20	120	0 min
11a	6Mbps	1	64	5320	5320.000	0.000	0.00	45	120	2 min
11a	6Mbps	1	64	5320	5320.000	0.000	0.00	-40	120	2 min
11a	6Mbps	1	64	5320	5320.000	0.000	0.00	20	132	2 min
11a	6Mbps	1	64	5320	5320.000	0.000	0.00	20	108	2 min
11a	6Mbps	1	64	5320	5320.000	0.000	0.00	20	120	2 min
11a	6Mbps	1	64	5320	5320.000	0.000	0.00	45	120	5 min
11a	6Mbps	1	64	5320	5320.050	0.050	9.40	-40	120	5 min
11a	6Mbps	1	64	5320	5320.000	0.000	0.00	20	132	5 min
11a	6Mbps	1	64	5320	5320.000	0.000	0.00	20	108	5 min
11a	6Mbps	1	64	5320	5320.000	0.000	0.00	20	120	5 min
11a	6Mbps	1	64	5320	5320.000	0.000	0.00	45	120	10 min
11a	6Mbps	1	64	5320	5320.050	0.050	9.40	-40	120	10 min
11a	6Mbps	1	64	5320	5320.000	0.000	0.00	20	132	10 min
11a	6Mbps	1	64	5320	5319.975	-0.025	-4.70	20	108	10 min
11a	6Mbps	1	64	5320	5320.000	0.000	0.00	20	120	10 min

Band III										
Mod.	Data Rate	NTX	CH.	Freq. (MHz)	Center Frequency (MHz)	Frequency Deviation (MHz)	Frequency Stability (ppm)	Temperature (°C)	Voltage (V)	Note
11a	6Mbps	1	100	5500	5500.000	0.000	0.00	45	120	0 min
11a	6Mbps	1	100	5500	5500.000	0.000	0.00	-40	120	0 min
11a	6Mbps	1	100	5500	5500.000	0.000	0.00	20	132	0 min
11a	6Mbps	1	100	5500	5500.000	0.000	0.00	20	108	0 min
11a	6Mbps	1	100	5500	5500.000	0.000	0.00	20	120	0 min
11a	6Mbps	1	100	5500	5500.000	0.000	0.00	45	120	2 min
11a	6Mbps	1	100	5500	5500.050	0.050	9.09	-40	120	2 min
11a	6Mbps	1	100	5500	5500.000	0.000	0.00	20	132	2 min
11a	6Mbps	1	100	5500	5500.000	0.000	0.00	20	108	2 min
11a	6Mbps	1	100	5500	5500.000	0.000	0.00	20	120	2 min
11a	6Mbps	1	100	5500	5500.000	0.000	0.00	45	120	5 min
11a	6Mbps	1	100	5500	5500.000	0.000	0.00	-40	120	5 min
11a	6Mbps	1	100	5500	5500.000	0.000	0.00	20	132	5 min
11a	6Mbps	1	100	5500	5500.000	0.000	0.00	20	108	5 min
11a	6Mbps	1	100	5500	5500.000	0.000	0.00	20	120	5 min
11a	6Mbps	1	100	5500	5500.000	0.000	0.00	45	120	10 min
11a	6Mbps	1	100	5500	5500.050	0.050	9.09	-40	120	10 min
11a	6Mbps	1	100	5500	5500.000	0.000	0.00	20	132	10 min
11a	6Mbps	1	100	5500	5500.000	0.000	0.00	20	108	10 min
11a	6Mbps	1	100	5500	5499.975	-0.025	-4.55	20	120	10 min



## Appendix B. AC Conducted Emission Test Results

Test Engineer :	Kai-Chun Chu	Temperature :	26~27°C
		Relative Humidity :	54~55%



# EUT Information

Report NO : 6N0107-01  
 Test Mode : Mode 1  
 Test Voltage : 120Vac/60Hz  
 Phase : Line

ENV216 Auto Test FCC Power Bar - L

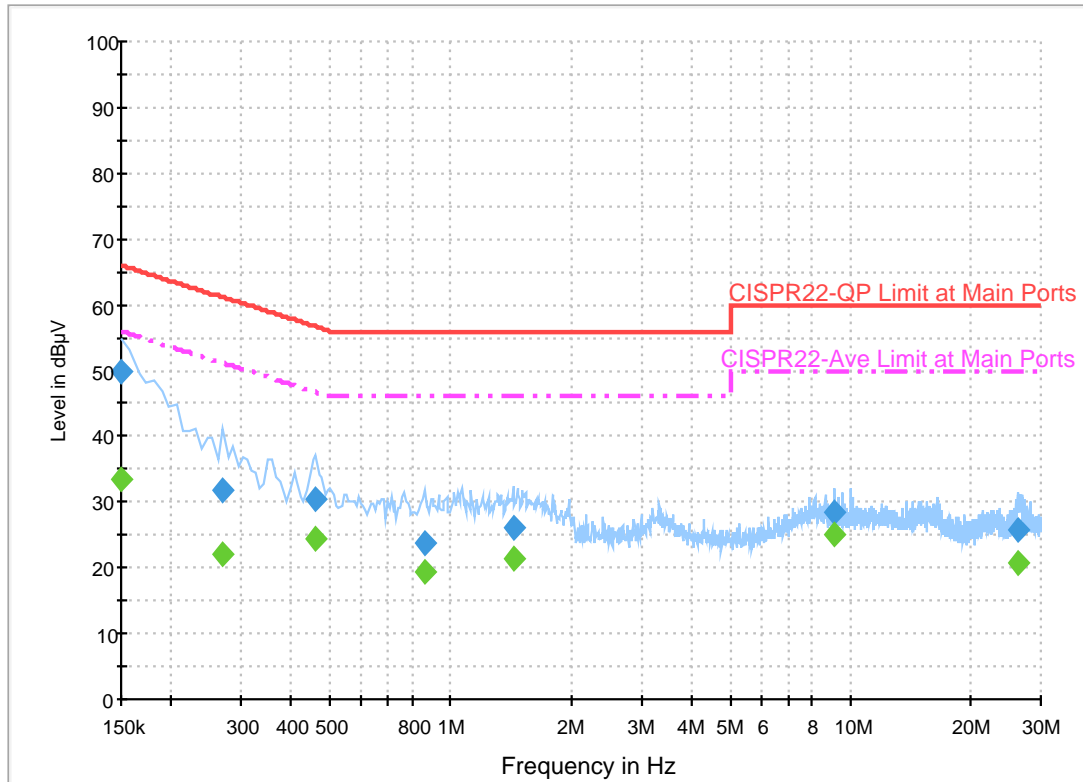

## Final Result 1

Frequency (MHz)	QuasiPeak (dBµV)	Filter	Line	Corr. (dB)	Margin (dB)	Limit (dBµV)
0.150000	49.9	Off	L1	19.6	16.1	66.0
0.270000	31.8	Off	L1	19.6	29.3	61.1
0.462000	30.6	Off	L1	19.6	26.1	56.7
0.862000	23.8	Off	L1	19.6	32.2	56.0
1.438000	26.1	Off	L1	19.6	29.9	56.0
9.110000	28.3	Off	L1	20.0	31.7	60.0
26.198000	25.6	Off	L1	20.8	34.4	60.0

## Final Result 2

Frequency (MHz)	Average (dBµV)	Filter	Line	Corr. (dB)	Margin (dB)	Limit (dBµV)
0.150000	33.4	Off	L1	19.6	22.6	56.0
0.270000	22.1	Off	L1	19.6	29.0	51.1
0.462000	24.4	Off	L1	19.6	22.3	46.7
0.862000	19.4	Off	L1	19.6	26.6	46.0
1.438000	21.3	Off	L1	19.6	24.7	46.0
9.110000	25.0	Off	L1	20.0	25.0	50.0
26.198000	20.8	Off	L1	20.8	29.2	50.0

# EUT Information

Report NO : 6N0107-01  
 Test Mode : Mode 1  
 Test Voltage : 120Vac/60Hz  
 Phase : Neutral

ENV216 Auto Test FCC Power Bar - N

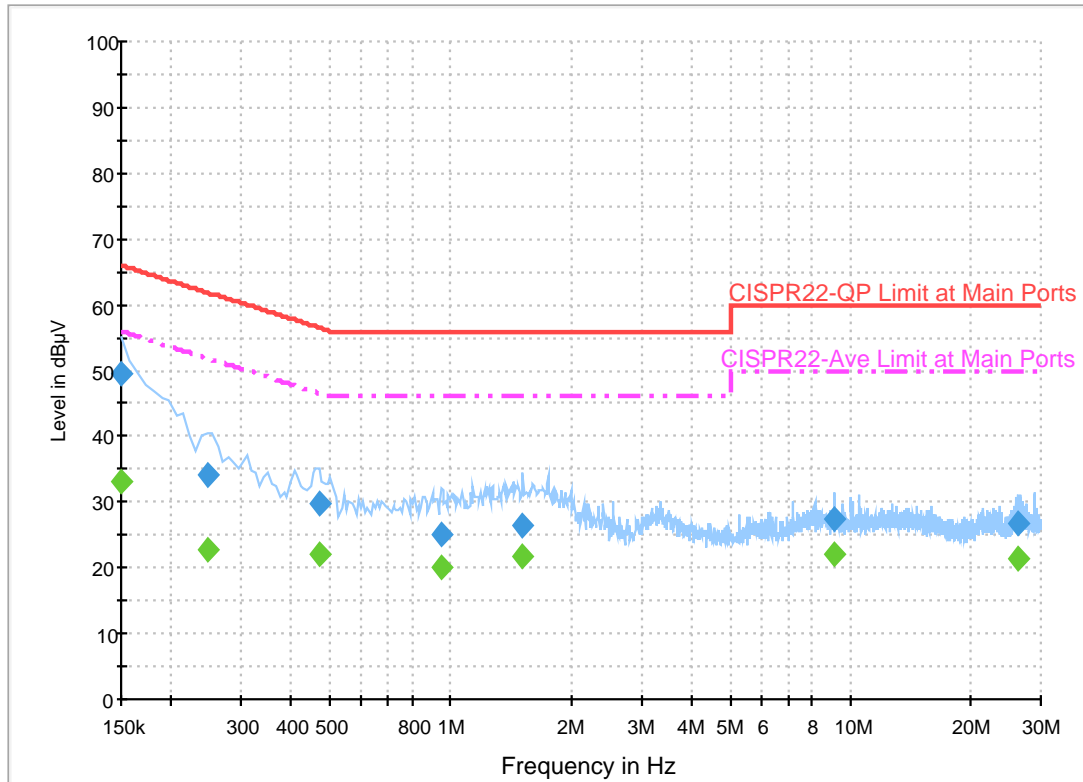

## Final Result 1

Frequency (MHz)	QuasiPeak (dBµV)	Filter	Line	Corr. (dB)	Margin (dB)	Limit (dBµV)
0.150000	49.6	Off	N	19.5	16.4	66.0
0.246000	34.1	Off	N	19.5	27.8	61.9
0.470000	29.9	Off	N	19.5	26.6	56.5
0.950000	25.2	Off	N	19.6	30.8	56.0
1.518000	26.4	Off	N	19.6	29.6	56.0
9.142000	27.5	Off	N	20.0	32.5	60.0
26.398000	26.7	Off	N	21.0	33.3	60.0

## Final Result 2

Frequency (MHz)	Average (dBµV)	Filter	Line	Corr. (dB)	Margin (dB)	Limit (dBµV)
0.150000	33.1	Off	N	19.5	22.9	56.0
0.246000	22.8	Off	N	19.5	29.1	51.9
0.470000	22.1	Off	N	19.5	24.4	46.5
0.950000	20.0	Off	N	19.6	26.0	46.0
1.518000	21.6	Off	N	19.6	24.4	46.0
9.142000	22.1	Off	N	20.0	27.9	50.0
26.398000	21.5	Off	N	21.0	28.5	50.0



## Appendix C. Radiated Spurious Emission

Test Engineer :	J.C. Liang, Jacky Huang, Ken Wu	Temperature :	20~24°C
		Relative Humidity :	50~54%

**Band 1 - 5150~5250MHz**  
**WIFI 802.11a (Band Edge @ 3m)**

WIFI Ant. 1+2	Note	Frequency ( MHz )	Level ( dBμV/m )	Over Limit ( dB )	Limit Line ( dBμV/m )	Read Level ( dBμV )	Antenna Factor ( dB/m )	Cable Loss ( dB )	Preamp Factor ( dB )	Ant Pos ( cm )	Table Pos ( deg )	Peak Avg. ( P/A )	Pol. ( H/V )
802.11a CH 36 5180MHz		5148.2	58.87	-15.13	74	50.8	32.05	9.05	33.03	249	272	P	H
		5148.98	51.37	-2.63	54	43.3	32.05	9.05	33.03	249	272	A	H
	*	5180	116.49	-	-	108.37	32.08	9.07	33.03	249	272	P	H
	*	5180	109.15	-	-	101.03	32.08	9.07	33.03	249	272	A	H
		5149.76	60.72	-13.28	74	52.65	32.05	9.05	33.03	100	275	P	V
		5150	52.68	-1.32	54	44.61	32.05	9.05	33.03	100	275	A	V
	*	5180	117.07	-	-	108.95	32.08	9.07	33.03	100	275	P	V
	*	5180	110.23	-	-	102.11	32.08	9.07	33.03	100	275	A	V
802.11a CH 44 5220MHz		5063.44	54.62	-19.38	74	46.7	31.97	8.99	33.04	217	263	P	H
		5147.16	46.42	-7.58	54	38.35	32.05	9.05	33.03	217	263	A	H
	*	5220	117	-	-	108.8	32.12	9.11	33.03	217	263	P	H
	*	5220	109.05	-	-	100.85	32.12	9.11	33.03	217	263	A	H
		5430.72	56.4	-17.6	74	47.83	32.33	9.26	33.02	217	263	P	H
		5431.2	50.03	-3.97	54	41.46	32.33	9.26	33.02	217	263	A	H
		5066.04	57	-17	74	49.08	31.97	8.99	33.04	100	279	P	V
		5064.74	49.62	-4.38	54	41.7	31.97	8.99	33.04	100	279	A	V
	*	5220	117.16	-	-	108.96	32.12	9.11	33.03	100	279	P	V
	*	5220	109.44	-	-	101.24	32.12	9.11	33.03	100	279	A	V
		5431.68	58.38	-15.62	74	49.81	32.33	9.26	33.02	100	279	P	V
	5442	51.18	-2.82	54	42.61	32.33	9.26	33.02	100	279	A	V	



<b>802.11a CH 48 5240MHz</b>		5097.76	53.75	-20.25	74	45.78	32	9.01	33.04	231	260	P	H
		5087.88	45.76	-8.24	54	37.81	31.98	9.01	33.04	231	260	A	H
	*	5240	108.93	-	-	100.71	32.13	9.12	33.03	231	260	P	H
	*	5240	116.55	-	-	108.33	32.13	9.12	33.03	231	260	A	H
		5452.56	57.57	-16.43	74	48.95	32.35	9.29	33.02	231	260	P	H
		5452.56	50.59	-3.41	54	41.97	32.35	9.29	33.02	231	260	A	H
		5085.02	57.3	-16.7	74	49.35	31.98	9.01	33.04	100	276	P	V
		5094.38	48.99	-5.01	54	41.02	32	9.01	33.04	100	276	A	V
	*	5240	117.93	-	-	109.71	32.13	9.12	33.03	100	276	P	V
	*	5240	109.4	-	-	101.18	32.13	9.12	33.03	100	276	A	V
		5457.36	57.9	-16.1	74	49.28	32.35	9.29	33.02	100	276	P	V
		5457.6	51.48	-2.52	54	42.86	32.35	9.29	33.02	100	276	A	V
Remark	1. No other spurious found. 2. All results are PASS against Peak and Average limit line.												



**Band 1 5150~5250MHz**  
**WIFI 802.11a (Harmonic @ 3m)**

WIFI Ant. 1+2	Note	Frequency ( MHz )	Level ( dBμV/m )	Over Limit ( dB )	Limit Line ( dBμV/m )	Read Level (dBμV)	Antenna Factor ( dB/m )	Cable Loss ( dB )	Preamp Factor ( dB )	Ant Pos ( cm )	Table Pos ( deg )	Peak Avg. (P/A)	Pol. (H/V)
802.11a CH 36 5180MHz		5398	56.99	-17.01	74	48.49	32.3	9.22	33.02	249	272	P	H
		5398	52.23	-1.77	54	43.73	32.3	9.22	33.02	249	272	A	H
		5614	56.54	-11.66	68.2	47.42	32.65	9.55	33.08	249	272	P	H
		10360	50.44	-17.76	68.2	61.16	38.41	14.63	64.07	100	0	P	H
		15540	45.15	-28.85	74	51.6	37.58	17.95	62.37	100	0	P	H
		4750	52.82	-21.18	74	45.58	31.51	8.82	33.09	100	275	P	V
		4750	48.87	-5.13	54	41.63	31.51	8.82	33.09	100	275	A	V
		5404	58.35	-15.65	74	49.85	32.3	9.22	33.02	100	275	P	V
		5404	53.32	-0.68	54	44.82	32.3	9.22	33.02	100	275	A	V
		10360	49.07	-19.13	68.2	60.1	38.41	14.63	64.07	100	0	P	V
	15540	45.49	-28.51	74	51.94	37.58	17.95	62.37	100	0	P	V	
802.11a CH 44 5220MHz		4792	52.47	-21.53	74	45.04	31.57	8.94	33.08	217	263	P	H
		4792	44.69	-9.31	54	37.26	31.57	8.94	33.08	217	263	A	H
		5656	61.55	-6.65	68.2	52.21	32.77	9.68	33.11	217	263	P	H
		10440	52.97	-15.23	68.2	63.56	38.51	14.68	64.09	280	319	P	H
		15660	45.14	-28.86	74	51.5	37.14	18.06	61.91	100	0	P	H
		4792	53.44	-20.56	74	46.01	31.57	8.94	33.08	100	279	P	V
		4792	44.54	-9.46	54	37.11	31.57	8.94	33.08	100	279	A	V
		10440	49.76	-18.44	68.2	60.66	38.51	14.68	64.09	100	0	P	V
	15660	45.88	-28.12	74	52.24	37.14	18.06	61.91	100	0	P	V	



<b>802.11a</b>  <b>CH 48</b>  <b>5240MHz</b>		4810	53.51	-20.49	74	45.92	31.6	9.07	33.08	231	260	P	H
		4810	44.86	-9.14	54	37.27	31.6	9.07	33.08	231	260	A	H
		5674	60.38	-7.82	68.2	51	32.81	9.68	33.11	231	260	P	H
		10480	52.52	-15.68	68.2	63.01	38.58	14.72	64.1	100	0	P	H
		15720	50.03	-23.97	74	56.36	36.89	18.1	61.65	100	0	P	H
		4798	54.05	-19.95	74	46.49	31.57	9.07	33.08	100	276	P	V
		4798	44.71	-9.29	54	37.15	31.57	9.07	33.08	100	276	A	V
		10480	50.17	-18.03	68.2	60.97	38.58	14.72	64.1	100	0	P	V
		15720	48.11	-25.89	74	54.44	36.89	18.1	61.65	100	0	P	V
<b>Remark</b>	1. No other spurious found. 2. All results are PASS against Peak and Average limit line.												



**Band 1 5150~5250MHz**  
**WIFI 802.11n HT20 (Band Edge @ 3m)**

WIFI Ant. 1+2	Note	Frequency ( MHz )	Level ( dBμV/m )	Over Limit ( dB )	Limit Line ( dBμV/m )	Read Level ( dBμV )	Antenna Factor ( dB/m )	Cable Loss ( dB )	Preamp Factor ( dB )	Ant Pos ( cm )	Table Pos ( deg )	Peak Avg. ( P/A )	Pol. ( H/V )
802.11n HT20 CH 36 5180MHz		5150	60.96	-13.04	74	52.89	32.05	9.05	33.03	220	270	P	H
		5150	53.42	-0.58	54	45.35	32.05	9.05	33.03	220	270	A	H
	*	5180	113.84	-	-	105.72	32.08	9.07	33.03	220	270	P	H
	*	5180	106.15	-	-	98.03	32.08	9.07	33.03	220	270	A	H
		5149.5	58.54	-15.46	74	50.47	32.05	9.05	33.03	100	265	P	V
		5150	49.91	-4.09	54	41.84	32.05	9.05	33.03	100	265	A	V
	*	5180	109.22	-	-	101.1	32.08	9.07	33.03	100	265	P	V
	*	5180	102.34	-	-	94.22	32.08	9.07	33.03	100	265	A	V
802.11n HT20 CH 44 5220MHz		5140.4	52.88	-21.12	74	44.81	32.05	9.05	33.03	217	272	P	H
		5150	44.53	-9.47	54	36.46	32.05	9.05	33.03	217	272	A	H
	*	5220	113.49	-	-	105.29	32.12	9.11	33.03	217	272	P	H
	*	5220	104.54	-	-	96.34	32.12	9.11	33.03	217	272	A	H
		5440.32	53.74	-20.26	74	45.17	32.33	9.26	33.02	217	272	P	H
		5429.76	46.25	-7.75	54	37.68	32.33	9.26	33.02	217	272	A	H
		5028.34	50.8	-23.2	74	42.96	31.93	8.95	33.04	100	251	P	V
		5139.1	42.08	-11.92	54	34.03	32.03	9.05	33.03	100	251	A	V
	*	5220	109.38	-	-	101.18	32.12	9.11	33.03	100	251	P	V
	*	5220	100.68	-	-	92.48	32.12	9.11	33.03	100	251	A	V
		5366.88	50.82	-23.18	74	42.38	32.27	9.2	33.03	100	251	P	V
		5429.52	43.22	-10.78	54	34.65	32.33	9.26	33.02	100	251	A	V



<b>802.11n</b>  <b>HT20</b>  <b>CH 48</b>  <b>5240MHz</b>		5134.94	52.68	-21.32	74	44.63	32.03	9.05	33.03	212	271	P	H
		5137.28	43.63	-10.37	54	35.58	32.03	9.05	33.03	212	271	A	H
	*	5240	113.47	-	-	105.25	32.13	9.12	33.03	212	271	P	H
	*	5240	104.8	-	-	96.58	32.13	9.12	33.03	212	271	A	H
		5459.52	53.63	-20.37	74	45.01	32.35	9.29	33.02	212	271	P	H
		5451.36	46.15	-7.85	54	37.53	32.35	9.29	33.02	212	271	A	H
		5017.16	49.88	-24.12	74	42.05	31.92	8.95	33.04	100	276	P	V
		5137.54	41.36	-12.64	54	33.31	32.03	9.05	33.03	100	276	A	V
	*	5240	109	-	-	100.78	32.13	9.12	33.03	100	276	P	V
	*	5240	100.59	-	-	92.37	32.13	9.12	33.03	100	276	A	V
		5452.32	49.96	-24.04	74	41.34	32.35	9.29	33.02	100	276	P	V
		5451.12	42.29	-11.71	54	33.67	32.35	9.29	33.02	100	276	A	V
<b>Remark</b>	1. No other spurious found. 2. All results are PASS against Peak and Average limit line.												





**Band 1 5150~5250MHz**  
**WIFI 802.11n HT20 (Harmonic @ 3m)**

WIFI Ant. 1+2	Note	Frequency ( MHz )	Level ( dBμV/m )	Over Limit ( dB )	Limit Line ( dBμV/m )	Read Level (dBμV)	Antenna Factor ( dB/m )	Cable Loss ( dB )	Preamp Factor ( dB )	Ant Pos ( cm )	Table Pos ( deg )	Peak Avg. (P/A)	Pol. (H/V)
802.11n HT20 CH 36 5180MHz		5392	54.99	-19.01	74	46.53	32.28	9.2	33.02	220	270	P	H
		5392	50.26	-3.74	54	41.8	32.28	9.2	33.02	220	270	A	H
		5614	58.3	-9.9	68.2	49.18	32.65	9.55	33.08	220	270	P	H
		10360	52.79	-15.41	68.2	63.51	38.41	14.63	64.07	100	0	P	H
		15540	47.68	-26.32	74	54.13	37.58	17.95	62.37	100	0	P	H
		5398	52.27	-21.73	74	43.77	32.3	9.22	33.02	100	265	P	V
		5398	48.09	-5.91	54	39.59	32.3	9.22	33.02	100	265	A	V
		10360	51.99	-16.21	68.2	63.02	38.41	14.63	64.07	100	0	P	V
		15540	48.17	-25.83	74	54.62	37.58	17.95	62.37	100	0	P	V
802.11n HT20 CH 44 5220MHz		5650	59.53	-8.67	68.2	50.25	32.77	9.61	33.1	217	272	P	H
		10440	51.37	-16.83	68.2	61.96	38.51	14.68	64.09	100	0	P	H
		15660	46.28	-27.72	74	52.64	37.14	18.06	61.91	100	0	P	H
		5656	55.94	-12.26	68.2	46.6	32.77	9.68	33.11	100	251	P	V
		10440	52.23	-15.97	68.2	63.13	38.51	14.68	64.09	100	0	P	V
		15660	48.09	-25.91	74	54.45	37.14	18.06	61.91	100	0	P	V
802.11n HT20 CH 48 5240MHz		5680	60.63	-7.57	68.2	51.19	32.81	9.75	33.12	212	271	P	H
		10480	51.04	-17.16	68.2	61.53	38.58	14.72	64.1	100	0	P	H
		15720	49.53	-24.47	74	55.86	36.89	18.1	61.65	100	0	P	H
		10480	52.19	-16.01	68.2	62.99	38.58	14.72	64.1	100	0	P	V
		15720	48.57	-25.43	74	54.9	36.89	18.1	61.65	100	0	P	V
Remark	1. No other spurious found. 2. All results are PASS against Peak and Average limit line.												



**Band 1 5150~5250MHz**  
**WIFI 802.11n HT40 (Band Edge @ 3m)**

WIFI Ant. 1+2	Note	Frequency ( MHz )	Level ( dBμV/m )	Over Limit ( dB )	Limit Line ( dBμV/m )	Read Level ( dBμV )	Antenna Factor ( dB/m )	Cable Loss ( dB )	Preamp Factor ( dB )	Ant Pos ( cm )	Table Pos ( deg )	Peak Avg. ( P/A )	Pol. ( H/V )
802.11n HT40 CH 38 5190MHz		5148.72	56.88	-17.12	74	48.81	32.05	9.05	33.03	100	294	P	H
		5148.2	50.52	-3.48	54	42.45	32.05	9.05	33.03	100	294	A	H
	*	5190	109.64	-	-	101.5	32.08	9.09	33.03	100	294	P	H
	*	5190	102.58	-	-	94.44	32.08	9.09	33.03	100	294	A	H
		5351.64	51.25	-22.75	74	42.84	32.25	9.19	33.03	100	294	P	H
		5353.88	43.35	-10.65	54	34.94	32.25	9.19	33.03	100	294	A	H
		5142.22	60.38	-13.62	74	52.31	32.05	9.05	33.03	100	280	P	V
		5150	52.96	-1.04	54	44.89	32.05	9.05	33.03	100	280	A	V
	*	5190	111.03	-	-	102.89	32.08	9.09	33.03	100	280	P	V
	*	5190	103.62	-	-	95.48	32.08	9.09	33.03	100	280	A	V
		5439.84	52.3	-21.7	74	43.73	32.33	9.26	33.02	100	280	P	V
		5350.8	44.27	-9.73	54	35.86	32.25	9.19	33.03	100	280	A	V
802.11n HT40 CH 46 5230MHz		5150	53.73	-20.27	74	45.66	32.05	9.05	33.03	100	295	P	H
		5150	45.67	-8.33	54	37.6	32.05	9.05	33.03	100	295	A	H
	*	5230	111.91	-	-	103.7	32.13	9.11	33.03	100	295	P	H
	*	5230	105.01	-	-	96.8	32.13	9.11	33.03	100	295	A	H
		5373.76	53.27	-20.73	74	44.82	32.27	9.2	33.02	100	295	P	H
		5373.48	45.23	-8.77	54	36.78	32.27	9.2	33.02	100	295	A	H
		5084.5	55.14	-18.86	74	47.19	31.98	9.01	33.04	100	278	P	V
		5150	46.51	-7.49	54	38.44	32.05	9.05	33.03	100	278	A	V
	*	5230	113.96	-	-	105.75	32.13	9.11	33.03	100	278	P	V
	*	5230	106.51	-	-	98.3	32.13	9.11	33.03	100	278	A	V
	5391.4	54.15	-19.85	74	45.69	32.28	9.2	33.02	100	278	P	V	
	5390.56	46.03	-7.97	54	37.57	32.28	9.2	33.02	100	278	A	V	
Remark	1. No other spurious found. 2. All results are PASS against Peak and Average limit line.												



Band 1 5150~5250MHz
WIFI 802.11n HT40 (Harmonic @ 3m)

Table with 14 columns: WIFI Ant. 1+2, Note, Frequency (MHz), Level (dBµV/m), Over Limit (dB), Limit Line (dBµV/m), Read Level (dBµV), Antenna Factor (dB/m), Cable Loss (dB), Preamp Factor (dB), Ant Pos (cm), Table Pos (deg), Peak Avg. (P/A), Pol. (H/V). Rows include data for 802.11n HT40 CH 38 (5190MHz) and 802.11n HT40 CH 46 (5230MHz). A Remark section at the bottom states: 1. No other spurious found. 2. All results are PASS against Peak and Average limit line.



**Band 1 5150~5250MHz  
WIFI 802.11ac VHT80 (Band Edge @ 3m)**

WIFI Ant. 1+2	Note	Frequency ( MHz )	Level ( dBμV/m )	Over Limit ( dB )	Limit Line ( dBμV/m )	Read Level (dBμV)	Antenna Factor ( dB/m )	Cable Loss ( dB )	Preamp Factor ( dB )	Ant Pos ( cm )	Table Pos ( deg )	Peak Avg. (P/A)	Pol. (H/V)
802.11ac VHT80 CH 42 5210MHz		5148.72	59.44	-14.56	74	51.37	32.05	9.05	33.03	100	293	P	H
		5148.72	50.97	-3.03	54	42.9	32.05	9.05	33.03	100	293	A	H
	*	5210	108.61	-	-	100.43	32.12	9.09	33.03	100	293	P	H
	*	5210	99.98	-	-	91.8	32.12	9.09	33.03	100	293	A	H
		5366.48	51.89	-22.11	74	43.46	32.27	9.19	33.03	100	293	P	H
		5350.52	43.94	-10.06	54	35.53	32.25	9.19	33.03	100	293	A	H
		5143.78	60.59	-13.41	74	52.52	32.05	9.05	33.03	100	278	P	V
		5148.46	52.53	-1.47	54	44.46	32.05	9.05	33.03	100	278	A	V
	*	5210	109.52	-	-	101.34	32.12	9.09	33.03	100	278	P	V
	*	5210	101.55	-	-	93.37	32.12	9.09	33.03	100	278	A	V
		5393.08	52.84	-21.16	74	44.36	32.28	9.22	33.02	100	278	P	V
	5350	44.52	-9.48	54	36.11	32.25	9.19	33.03	100	278	A	V	
Remark	1. No other spurious found. 2. All results are PASS against Peak and Average limit line.												



Band 1 5150~5250MHz

WIFI 802.11ac VHT80 (Harmonic @ 3m)

WIFI Ant. 1+2	Note	Frequency ( MHz )	Level ( dBμV/m )	Over Limit ( dB )	Limit Line ( dBμV/m )	Read Level (dBμV)	Antenna Factor ( dB/m )	Cable Loss ( dB )	Preamp Factor ( dB )	Ant Pos ( cm )	Table Pos ( deg )	Peak Avg. (P/A)	Pol. (H/V)
802.11ac		10420	45.53	-28.47	74	56.15	38.48	14.67	64.08	100	0	P	H
VHT80		15630	42.91	-31.09	74	49.3	37.2	18.03	61.98	100	0	P	H
CH 42		10420	45.42	-28.58	74	56.35	38.48	14.67	64.08	100	0	P	V
5210MHz		15630	43.76	-30.24	74	50.15	37.2	18.03	61.98	100	0	P	V
Remark	1. No other spurious found. 2. All results are PASS against Peak and Average limit line.												



**Band 2 - 5250~5350MHz**  
**WIFI 802.11a (Band Edge @ 3m)**

WIFI Ant.	Note	Frequency	Level	Over Limit	Limit Line	Read Level	Antenna Factor	Cable Loss	Preamp Factor	Ant Pos	Table Pos	Peak Avg.	Pol.
1+2		( MHz )	( dBμV/m )	( dB )	( dBμV/m )	( dBμV )	( dB/m )	( dB )	( dB )	( cm )	( deg )	( P/A )	( H/V )
802.11a CH 52 5260MHz		5108.42	53.52	-20.48	74	45.51	32.02	9.03	33.04	274	269	P	H
		5108.42	45.99	-8.01	54	37.98	32.02	9.03	33.04	274	269	A	H
	*	5260	115.78	-	-	107.52	32.17	9.12	33.03	274	269	P	H
	*	5260	108.36	-	-	100.1	32.17	9.12	33.03	274	269	A	H
		5402.64	55.34	-18.66	74	46.84	32.3	9.22	33.02	274	269	P	H
		5406.72	47.04	-6.96	54	38.54	32.3	9.22	33.02	274	269	A	H
		5110.5	55.53	-18.47	74	47.52	32.02	9.03	33.04	100	278	P	V
		5104.52	48.8	-5.2	54	40.83	32	9.01	33.04	100	278	A	V
	*	5260	115.69	-	-	107.43	32.17	9.12	33.03	100	278	P	V
	*	5260	109.04	-	-	100.78	32.17	9.12	33.03	100	278	A	V
		5411.04	55.53	-18.47	74	47.03	32.3	9.22	33.02	100	278	P	V
		5416.32	48.56	-5.44	54	40.04	32.32	9.22	33.02	100	278	A	V
802.11a CH 60 5300MHz		5072.08	52.79	-21.21	74	44.86	31.98	8.99	33.04	224	267	P	H
		5147.56	46.05	-7.95	54	37.98	32.05	9.05	33.03	224	267	A	H
	*	5300	115.7	-	-	107.37	32.2	9.16	33.03	224	267	P	H
	*	5300	108.98	-	-	100.65	32.2	9.16	33.03	224	267	A	H
		5354.4	55.94	-18.06	74	47.53	32.25	9.19	33.03	224	267	P	H
		5350.32	47.65	-6.35	54	39.24	32.25	9.19	33.03	224	267	A	H
		5149.26	55.92	-18.08	74	47.85	32.05	9.05	33.03	100	276	P	V
		5149.26	48.27	-5.73	54	40.2	32.05	9.05	33.03	100	276	A	V
	*	5300	115.44	-	-	107.11	32.2	9.16	33.03	100	276	P	V
	*	5300	108.23	-	-	99.9	32.2	9.16	33.03	100	276	A	V
		5450.16	57.3	-16.7	74	48.68	32.35	9.29	33.02	100	276	P	V
		5456.88	49.74	-4.26	54	41.12	32.35	9.29	33.02	100	276	A	V



<b>802.11a</b> <b>CH 64</b> <b>5320MHz</b>	*	5320	115.62	-	-	107.26	32.22	9.17	33.03	223	262	P	H
	*	5320	107.82	-	-	99.46	32.22	9.17	33.03	223	262	A	H
		5354.24	61.52	-12.48	74	53.11	32.25	9.19	33.03	223	262	P	H
		5350.08	53.64	-0.36	54	45.23	32.25	9.19	33.03	223	262	A	H
	*	5320	115.47	-	-	107.11	32.22	9.17	33.03	100	273	P	V
	*	5320	107.76	-	-	99.4	32.22	9.17	33.03	100	273	A	V
		5350.56	57.63	-16.37	74	49.22	32.25	9.19	33.03	100	273	P	V
		5350.08	52.19	-1.81	54	43.78	32.25	9.19	33.03	100	273	A	V
<b>Remark</b>	1. No other spurious found. 2. All results are PASS against Peak and Average limit line.												



**Band 2 5250~5350MHz**  
**WIFI 802.11a (Harmonic @ 3m)**

WIFI Ant. 1+2	Note	Frequency ( MHz )	Level ( dBμV/m )	Over Limit ( dB )	Limit Line ( dBμV/m )	Read Level (dBμV)	Antenna Factor ( dB/m )	Cable Loss ( dB )	Preamp Factor ( dB )	Ant Pos ( cm )	Table Pos ( deg )	Peak Avg. (P/A)	Pol. (H/V)
802.11a CH 52 5260MHz		5476	57.5	-10.7	68.2	48.82	32.37	9.33	33.02	274	269	P	H
		5704	60.59	-7.61	68.2	51.06	32.9	9.75	33.12	274	269	P	H
		10520	51.64	-16.56	68.2	62.07	38.62	14.74	64.1	100	0	P	H
		15780	46.85	-27.15	74	53.13	36.71	18.15	61.45	100	0	P	H
		4822	52.98	-21.02	74	45.39	31.62	9.05	33.08	100	278	P	V
		4822	44.33	-9.67	54	36.74	31.62	9.05	33.08	100	278	A	V
		5476	59.23	-8.97	68.2	50.55	32.37	9.33	33.02	100	278	P	V
		10520	52.39	-15.81	68.2	63.13	38.62	14.74	64.1	100	0	P	V
		15780	47.14	-26.86	74	53.42	36.71	18.15	61.45	100	0	P	V
802.11a CH 60 5300MHz		4858	53.73	-20.27	74	46.09	31.68	9.03	33.07	224	267	P	H
		4858	45.65	-8.35	54	38.01	31.68	9.03	33.07	224	267	A	H
		5518	57.13	-11.07	68.2	48.35	32.44	9.37	33.03	224	267	P	H
		5740	62.65	-5.55	68.2	52.94	32.98	9.88	33.15	224	267	P	H
		10600	53.53	-20.47	74	63.78	38.72	14.8	64.08	100	244	P	H
		10600	44.93	-9.07	54	55.18	38.72	14.8	64.08	100	244	A	H
		15900	50.12	-23.88	74	56.31	36.27	18.25	60.99	100	0	P	H
		4852	54.54	-19.46	74	46.9	31.68	9.03	33.07	100	276	P	V
		4852	45.12	-8.88	54	37.48	31.68	9.03	33.07	100	276	A	V
		5524	59.71	-8.49	68.2	50.89	32.44	9.41	33.03	100	276	P	V
		5740	55.29	-12.91	68.2	45.58	32.98	9.88	33.15	100	276	P	V
		10600	54.55	-19.45	74	65.11	38.72	14.8	64.08	263	256	P	V
		10600	46.49	-7.51	54	57.05	38.72	14.8	64.08	263	256	A	V
	15900	49.38	-24.62	74	55.57	36.27	18.25	60.99	100	0	P	V	





<b>802.11a CH 64 5320MHz</b>		4870	53.85	-20.15	74	46.18	31.71	9.03	33.07	223	262	P	H
		4870	44.7	-9.3	54	37.03	31.71	9.03	33.07	223	262	A	H
		5470	56.2	-12	68.2	47.56	32.37	9.29	33.02	223	262	P	H
		5542	58.7	-9.5	68.2	49.86	32.48	9.41	33.05	223	262	P	H
		5770	60.11	-8.09	68.2	50.26	33.06	9.95	33.16	223	262	P	H
		10640	52.28	-21.72	74	62.46	38.77	14.82	64.07	100	242	P	H
		10640	44	-10	54	54.18	38.77	14.82	64.07	100	242	A	H
		15960	48.01	-25.99	74	54.16	36.02	18.3	60.73	100	0	P	H
		4882	56.78	-17.22	74	49.13	31.71	9.01	33.07	100	273	P	V
		4882	47.37	-6.63	54	39.72	31.71	9.01	33.07	100	273	A	V
		5476	58.42	-9.78	68.2	49.74	32.37	9.33	33.02	100	273	P	V
		5548	61.13	-7.07	68.2	52.25	32.52	9.41	33.05	100	273	P	V
		5764	56.44	-11.76	68.2	46.63	33.02	9.95	33.16	100	273	P	V
		10640	53.81	-20.19	74	64.29	38.77	14.82	64.07	254	255	P	V
		10640	44.68	-9.32	54	55.16	38.77	14.82	64.07	254	255	A	V
		15960	42.38	-31.62	74	48.53	36.02	18.3	60.73	100	0	P	V
<b>Remark</b>	<ol style="list-style-type: none"> <li>1. No other spurious found.</li> <li>2. All results are PASS against Peak and Average limit line.</li> </ol>												



**Band 2 5250~5350MHz**  
**WIFI 802.11n HT20 (Band Edge @ 3m)**

WIFI Ant. 1+2	Note	Frequency ( MHz )	Level ( dBμV/m )	Over Limit ( dB )	Limit Line ( dBμV/m )	Read Level ( dBμV )	Antenna Factor ( dB/m )	Cable Loss ( dB )	Preamp Factor ( dB )	Ant Pos ( cm )	Table Pos ( deg )	Peak Avg. ( P/A )	Pol. ( H/V )
802.11n HT20 CH 52 5260MHz		5145.34	52.95	-21.05	74	44.88	32.05	9.05	33.03	212	271	P	H
		5148.2	43.49	-10.51	54	35.42	32.05	9.05	33.03	212	271	A	H
	*	5260	113.88	-	-	105.62	32.17	9.12	33.03	212	271	P	H
	*	5260	104.98	-	-	96.72	32.17	9.12	33.03	212	271	A	H
		5370.72	54.52	-19.48	74	46.08	32.27	9.2	33.03	212	271	P	H
		5365.92	44.13	-9.87	54	35.7	32.27	9.19	33.03	212	271	A	H
		5142.22	50.71	-23.29	74	42.64	32.05	9.05	33.03	100	269	P	V
		5143.26	41.52	-12.48	54	33.45	32.05	9.05	33.03	100	269	A	V
	*	5260	110.27	-	-	102.01	32.17	9.12	33.03	100	269	P	V
	*	5260	100.67	-	-	92.41	32.17	9.12	33.03	100	269	A	V
		5366.4	50.32	-23.68	74	41.89	32.27	9.19	33.03	100	269	P	V
		5368.32	41.28	-12.72	54	32.84	32.27	9.2	33.03	100	269	A	V
802.11n HT20 CH 60 5300MHz		5145.86	53.47	-20.53	74	45.4	32.05	9.05	33.03	213	262	P	H
		5146.54	45.52	-8.48	54	37.45	32.05	9.05	33.03	213	262	A	H
	*	5300	117.13	-	-	108.8	32.2	9.16	33.03	213	262	P	H
	*	5300	108.48	-	-	100.15	32.2	9.16	33.03	213	262	A	H
		5352.48	56.52	-17.48	74	48.11	32.25	9.19	33.03	213	262	P	H
		5350.08	48.8	-5.2	54	40.39	32.25	9.19	33.03	213	262	A	H
		5145.18	55.36	-18.64	74	47.29	32.05	9.05	33.03	206	272	P	V
		5147.22	47.14	-6.86	54	39.07	32.05	9.05	33.03	206	272	A	V
	*	5300	116.27	-	-	107.94	32.2	9.16	33.03	100	272	P	V
	*	5300	109.13	-	-	100.8	32.2	9.16	33.03	100	272	A	V
	5410.32	56.44	-17.56	74	47.94	32.3	9.22	33.02	100	272	P	V	
	5455.92	49.27	-4.73	54	40.65	32.35	9.29	33.02	100	272	A	V	



<b>802.11n</b> <b>HT20</b> <b>CH 64</b> <b>5320MHz</b>	*	5320	115.2	-	-	106.84	32.22	9.17	33.03	227	261	P	H
	*	5320	108.14	-	-	99.78	32.22	9.17	33.03	227	261	A	H
		5353.76	61.93	-12.07	74	53.52	32.25	9.19	33.03	227	261	P	H
		5350.08	53	-1	54	44.59	32.25	9.19	33.03	227	261	A	H
	*	5320	115.62	-	-	107.26	32.22	9.17	33.03	100	274	P	V
	*	5320	108.56	-	-	100.2	32.22	9.17	33.03	100	274	A	V
		5350.4	60.41	-13.59	74	52	32.25	9.19	33.03	100	274	P	V
		5350.08	52.33	-1.67	54	43.92	32.25	9.19	33.03	100	274	A	V
<b>Remark</b>	1. No other spurious found. 2. All results are PASS against Peak and Average limit line.												



**Band 2 5250~5350MHz**  
**WIFI 802.11n HT20 (Harmonic @ 3m)**

WIFI Ant. 1+2	Note	Frequency ( MHz )	Level ( dBμV/m )	Over Limit ( dB )	Limit Line ( dBμV/m )	Read Level (dBμV)	Antenna Factor ( dB/m )	Cable Loss ( dB )	Preamp Factor ( dB )	Ant Pos ( cm )	Table Pos ( deg )	Peak Avg. (P/A)	Pol. (H/V)
802.11n HT20 CH 52 5260MHz		5476	55.9	-12.3	68.2	47.22	32.37	9.33	33.02	212	271	P	H
		5698	62.41	-5.79	68.2	52.92	32.86	9.75	33.12	212	271	P	H
		10520	49.45	-18.75	68.2	59.88	38.62	14.74	64.1	100	0	P	H
		15780	44.78	-29.22	74	51.06	36.71	18.15	61.45	100	0	P	H
		10520	53.23	-14.97	68.2	63.97	38.62	14.74	64.1	100	284	P	V
		10520	43.07	-10.93	54	53.81	38.62	14.74	64.1	100	284	A	V
		15780	44.46	-29.54	74	50.74	36.71	18.15	61.45	100	0	P	V
802.11n HT20 CH 60 5300MHz		4852	56.82	-17.18	74	49.18	31.68	9.03	33.07	100	262	P	H
		4852	47.44	-6.56	54	39.8	31.68	9.03	33.07	100	262	A	H
		5530	57.18	-11.02	68.2	48.38	32.44	9.41	33.05	213	262	P	H
		5734	60.58	-7.62	68.2	50.91	32.94	9.88	33.15	213	262	P	H
		10600	53.7	-20.3	74	63.95	38.72	14.8	64.08	100	244	P	H
		10600	43.42	-10.58	54	53.67	38.72	14.8	64.08	100	244	A	H
		15900	47.22	-26.78	74	53.41	36.27	18.25	60.99	100	0	P	H
		4858	56.54	-17.46	74	48.9	31.68	9.03	33.07	100	302	P	V
		4858	47.44	-6.56	54	39.8	31.68	9.03	33.07	100	302	A	V
		5524	60.73	-7.47	68.2	51.91	32.44	9.41	33.03	100	272	P	V
		5734	56.25	-11.95	68.2	46.58	32.94	9.88	33.15	100	272	P	V
		10600	49.88	-24.12	74	60.44	38.72	14.8	64.08	100	0	P	V
		15900	46.59	-27.41	74	52.78	36.27	18.25	60.99	100	0	P	V



<b>802.11n</b> <b>HT20</b> <b>CH 64</b> <b>5320MHz</b>		4876	54.88	-19.12	74	47.23	31.71	9.01	33.07	100	261	P	H
		4876	45.7	-8.3	54	38.05	31.71	9.01	33.07	100	261	A	H
		5464	55.95	-12.25	68.2	47.31	32.37	9.29	33.02	227	261	P	H
		5536	58.83	-9.37	68.2	49.99	32.48	9.41	33.05	227	261	P	H
		5764	59.55	-8.65	68.2	49.74	33.02	9.95	33.16	227	261	P	H
		10640	47.58	-26.42	74	57.76	38.77	14.82	64.07	100	0	P	H
		15960	46.32	-27.68	74	52.47	36.02	18.3	60.73	100	0	P	H
		4882	56.9	-17.1	74	49.25	31.71	9.01	33.07	100	296	P	V
		4882	47.21	-6.79	54	39.56	31.71	9.01	33.07	100	296	A	V
		5476	59.29	-8.91	68.2	50.61	32.37	9.33	33.02	100	274	P	V
		5542	59.8	-8.4	68.2	50.96	32.48	9.41	33.05	100	274	P	
		5758	56.5	-11.7	68.2	46.69	33.02	9.95	33.16	100	274	P	
		10640	48.44	-25.56	74	58.92	38.77	14.82	64.07	100	0	P	
		15960	44.42	-29.58	74	50.57	36.02	18.3	60.73	100	0	P	V
<b>Remark</b>	1. No other spurious found. 2. All results are PASS against Peak and Average limit line.												



**Band 2 5250~5350MHz**  
**WIFI 802.11n HT40 (Band Edge @ 3m)**

WIFI Ant. 1+2	Note	Frequency ( MHz )	Level ( dBμV/m )	Over Limit ( dB )	Limit Line ( dBμV/m )	Read Level ( dBμV )	Antenna Factor ( dB/m )	Cable Loss ( dB )	Preamp Factor ( dB )	Ant Pos ( cm )	Table Pos ( deg )	Peak Avg. ( P/A )	Pol. ( H/V )
802.11n HT40 CH 54 5270MHz		5121.38	52.46	-21.54	74	44.44	32.02	9.03	33.03	100	242	P	H
		5131.24	44.24	-9.76	54	36.21	32.03	9.03	33.03	100	242	A	H
	*	5270	112.61	-	-	104.33	32.17	9.14	33.03	100	242	P	H
	*	5270	105.51	-	-	97.23	32.17	9.14	33.03	100	242	A	H
		5351.52	55.3	-18.7	74	46.89	32.25	9.19	33.03	100	242	P	H
		5351.28	47.68	-6.32	54	39.27	32.25	9.19	33.03	100	242	A	H
		5126.14	54	-20	74	45.97	32.03	9.03	33.03	100	271	P	V
		5125.12	45.58	-8.42	54	37.55	32.03	9.03	33.03	100	271	A	V
	*	5270	114.03	-	-	105.75	32.17	9.14	33.03	100	271	P	V
	*	5270	106.3	-	-	98.02	32.17	9.14	33.03	100	271	A	V
		5405.76	55.71	-18.29	74	47.21	32.3	9.22	33.02	100	271	P	V
		5350.08	47.24	-6.76	54	38.83	32.25	9.19	33.03	100	271	A	V
802.11n HT40 CH 62 5310MHz		5114.92	50.99	-23.01	74	42.98	32.02	9.03	33.04	226	262	P	H
		5149.26	42.94	-11.06	54	34.87	32.05	9.05	33.03	226	262	A	H
	*	5310	111.14	-	-	102.79	32.22	9.16	33.03	226	262	P	H
	*	5310	103.21	-	-	94.86	32.22	9.16	33.03	226	262	A	H
		5350.32	59.69	-14.31	74	51.28	32.25	9.19	33.03	226	262	P	H
		5350.08	51.98	-2.02	54	43.57	32.25	9.19	33.03	226	262	A	H
		5147.56	51.92	-22.08	74	43.85	32.05	9.05	33.03	178	274	P	V
		5113.22	44.03	-9.97	54	36.02	32.02	9.03	33.04	178	274	A	V
	*	5310	110.93	-	-	102.58	32.22	9.16	33.03	178	274	P	V
	*	5310	103.42	-	-	95.07	32.22	9.16	33.03	178	274	A	V
	5350.08	59.36	-14.64	74	50.95	32.25	9.19	33.03	178	274	P	V	
	5350.08	50.72	-3.28	54	42.31	32.25	9.19	33.03	178	274	A	V	
Remark	1. No other spurious found. 2. All results are PASS against Peak and Average limit line.												



**Band 2 5250~5350MHz**  
**WIFI 802.11n HT40 (Harmonic @ 3m)**

WIFI Ant. 1+2	Note	Frequency ( MHz )	Level ( dBμV/m )	Over Limit ( dB )	Limit Line ( dBμV/m )	Read Level (dBμV)	Antenna Factor ( dB/m )	Cable Loss ( dB )	Preamp Factor ( dB )	Ant Pos ( cm )	Table Pos ( deg )	Peak Avg. (P/A)	Pol. (H/V)
802.11n		10540	47.95	-26.05	74	58.33	38.64	14.76	64.09	100	0	P	H
HT40		15810	45.73	-28.27	74	51.98	36.58	18.18	61.32	100	0	P	H
CH 54		10540	47.87	-26.13	74	58.56	38.64	14.76	64.09	100	0	P	V
5270MHz		15810	45.3	-28.7	74	51.55	36.58	18.18	61.32	100	0	P	V
802.11n		10620	45.99	-28.01	74	56.22	38.74	14.81	64.08	100	0	P	H
HT40		15930	42.91	-31.09	74	49.07	36.15	18.28	60.86	100	0	P	H
CH 62		10620	47.31	-26.69	74	57.84	38.74	14.81	64.08	100	0	P	V
5310MHz		15930	42.57	-31.43	74	48.73	36.15	18.28	60.86	100	0	P	V
Remark	1. No other spurious found. 2. All results are PASS against Peak and Average limit line.												



**Band 2 5250~5350MHz**  
**WIFI 802.11ac VHT80 (Band Edge @ 3m)**

WIFI Ant. 1+2	Note	Frequency ( MHz )	Level ( dBμV/m )	Over Limit ( dB )	Limit Line ( dBμV/m )	Read Level (dBμV)	Antenna Factor ( dB/m )	Cable Loss ( dB )	Preamp Factor ( dB )	Ant Pos ( cm )	Table Pos ( deg )	Peak Avg. (P/A)	Pol. (H/V)
802.11ac VHT80 CH 58 5290MHz		5106.42	52.39	-21.61	74	44.4	32.02	9.01	33.04	100	258	P	H
		5149.6	44.34	-9.66	54	36.27	32.05	9.05	33.03	100	258	A	H
	*	5290	107.82	-	-	99.51	32.18	9.16	33.03	100	258	P	H
	*	5290	99.88	-	-	91.57	32.18	9.16	33.03	100	258	A	H
		5354.4	60.46	-13.54	74	52.05	32.25	9.19	33.03	100	258	P	H
		5351.76	52.82	-1.18	54	44.41	32.25	9.19	33.03	100	258	A	H
		5145.18	53.06	-20.94	74	44.99	32.05	9.05	33.03	100	273	P	V
		5149.94	44.92	-9.08	54	36.85	32.05	9.05	33.03	100	273	A	V
	*	5290	108.41	-	-	100.1	32.18	9.16	33.03	100	273	P	V
	*	5290	100.9	-	-	92.59	32.18	9.16	33.03	100	273	A	V
		5368.32	60.5	-13.5	74	52.06	32.27	9.2	33.03	100	273	P	V
	5350.32	52.91	-1.09	54	44.5	32.25	9.19	33.03	100	273	A	V	
Remark	1. No other spurious found. 2. All results are PASS against Peak and Average limit line.												





Band 2 5250~5350MHz

WIFI 802.11ac VHT80 (Harmonic @ 3m)

WIFI Ant. 1+2	Note	Frequency ( MHz )	Level ( dBμV/m )	Over Limit ( dB )	Limit Line ( dBμV/m )	Read Level (dBμV)	Antenna Factor ( dB/m )	Cable Loss ( dB )	Preamp Factor ( dB )	Ant Pos ( cm )	Table Pos ( deg )	Peak Avg. (P/A)	Pol. (H/V)
802.11ac		10580	44.54	-29.46	74	54.83	38.7	14.78	64.08	100	0	P	H
VHT80		15870	41.99	-32.01	74	48.21	36.33	18.22	61.06	100	0	P	H
CH 58		10580	45.45	-28.55	74	56.05	38.7	14.78	64.08	100	0	P	V
5290MHz		15870	42.6	-31.4	74	48.82	36.33	18.22	61.06	100	0	P	V
Remark	1. No other spurious found. 2. All results are PASS against Peak and Average limit line.												



**Band 3 - 5470~5725MHz**  
**WIFI 802.11a (Band Edge @ 3m)**

WIFI Ant.	Note	Frequency	Level	Over Limit	Limit Line	Read Level	Antenna Factor	Cable Loss	Preamp Factor	Ant Pos	Table Pos	Peak Avg.	Pol.
1+2		( MHz )	( dBμV/m )	( dB )	( dBμV/m )	( dBμV )	( dB/m )	( dB )	( dB )	( cm )	( deg )	( P/A )	( H/V )
802.11a CH 100 5500MHz		5457.84	57.78	-16.22	74	49.16	32.35	9.29	33.02	100	242	P	H
		5469.84	67.53	-0.67	68.2	58.89	32.37	9.29	33.02	100	242	P	H
		5458.96	50.18	-3.82	54	41.56	32.35	9.29	33.02	100	242	P	H
	*	5500	117.58	-	-	108.83	32.4	9.37	33.02	100	242	P	H
	*	5500	109.76	-	-	101.01	32.4	9.37	33.02	100	242	A	H
		5458.96	58.99	-15.01	74	50.37	32.35	9.29	33.02	100	269	P	V
		5469.04	66.45	-1.75	68.2	57.81	32.37	9.29	33.02	100	269	P	V
		5459.92	51.45	-2.55	54	42.83	32.35	9.29	33.02	100	269	A	V
	*	5500	117.4	-	-	108.65	32.4	9.37	33.02	100	269	P	V
	*	5500	107.04	-	-	98.29	32.4	9.37	33.02	100	269	A	V
802.11a CH 116 5580MHz		5431.6	55.88	-18.12	74	47.31	32.33	9.26	33.02	100	244	P	H
		5464	53.23	-14.97	68.2	44.59	32.37	9.29	33.02	100	244	P	H
		5431.6	46.66	-7.34	54	38.09	32.33	9.26	33.02	100	244	A	H
	*	5580	116.43	-	-	107.45	32.57	9.48	33.07	100	244	P	H
	*	5580	108.22	-	-	99.24	32.57	9.48	33.07	100	244	A	H
		5725.31	55.31	-12.89	68.2	45.69	32.94	9.81	33.13	100	244	P	H
		5432.08	54.01	-19.99	74	45.44	32.33	9.26	33.02	100	262	P	V
		5463.04	56.54	-11.66	68.2	47.9	32.37	9.29	33.02	100	262	P	V
		5433.28	46.52	-7.48	54	37.95	32.33	9.26	33.02	100	262	A	V
	*	5580	116.48	-	-	107.5	32.57	9.48	33.07	100	262	P	V
	*	5580	109.06	-	-	100.08	32.57	9.48	33.07	100	262	A	V
	5730.035	59.04	-9.16	68.2	49.42	32.94	9.81	33.13	100	262	P	V	



<b>802.11a CH 140 5700MHz</b>	*	5700	113.82	-	-	104.33	32.86	9.75	33.12	100	255	P	H
	*	5700	106.14	-	-	96.65	32.86	9.75	33.12	100	255	A	H
		5727.4	63.42	-4.78	68.2	53.8	32.94	9.81	33.13	100	255	P	H
	*	5700	115.87	-	-	106.38	32.86	9.75	33.12	100	259	P	V
	*	5700	107.71	-	-	98.22	32.86	9.75	33.12	100	259	A	V
		5729.32	66.91	-1.29	68.2	57.29	32.94	9.81	33.13	100	259	P	V
<b>Remark</b>	1. No other spurious found. 2. All results are PASS against Peak and Average limit line.												



**Band 3 - 5470~5725MHz**  
**WIFI 802.11a (Harmonic @ 3m)**

WIFI Ant. 1+2	Note	Frequency ( MHz )	Level ( dBμV/m )	Over Limit ( dB )	Limit Line ( dBμV/m )	Read Level ( dBμV )	Antenna Factor ( dB/m )	Cable Loss ( dB )	Preamp Factor ( dB )	Ant Pos ( cm )	Table Pos ( deg )	Peak Avg. ( P/A )	Pol. ( H/V )
802.11a CH 100 5500MHz		5032	55.1	-18.9	74	47.24	31.93	8.97	33.04	100	242	P	H
		5032	48.01	-5.99	54	40.15	31.93	8.97	33.04	100	262	A	H
		5644	56.76	-11.44	68.2	47.52	32.73	9.61	33.1	100	242	P	H
		5722	56.44	-11.76	68.2	46.82	32.94	9.81	33.13	100	242	P	H
		5956	57.31	-10.89	68.2	47.01	33.52	10.02	33.24	100	242	P	H
		11000	54.72	-19.28	74	64.14	39.2	15.08	64	100	316	P	H
		11000	45.25	-8.75	54	54.67	39.2	15.08	64	100	316	A	H
		16500	45.03	-23.17	68.2	51.59	37.1	18.74	62.7	100	0	P	H
		5038	54.55	-19.45	74	46.67	31.95	8.97	33.04	100	269	P	V
		5038	48.27	-5.73	54	40.39	31.95	8.97	33.04	100	269	A	V
		5644	60.35	-7.85	68.2	51.11	32.73	9.61	33.1	100	269	P	V
		5734	60.86	-7.34	68.2	51.19	32.94	9.88	33.15	100	269	P	V
		5950	57	-11.2	68.2	46.74	33.48	10.02	33.24	100	269	P	V
		11000	54.57	-19.43	74	64.29	39.2	15.08	64	100	273	P	V
		11000	44.46	-9.54	54	54.18	39.2	15.08	64	100	273	A	V
		16500	43.2	-25	68.2	49.76	37.1	18.74	62.7	100	0	P	V
802.11a CH 116 5580MHz		5806	57.12	-11.08	68.2	47.14	33.14	10.01	33.17	100	244	P	H
		6052	54.8	-13.4	68.2	44.31	33.68	10.09	33.28	100	244	P	H
		11160	55.08	-18.92	74	64.29	38.97	15.2	63.67	100	327	P	H
		11160	45.62	-8.38	54	54.83	38.97	15.2	63.67	100	327	A	H
		16740	44.39	-23.81	68.2	48.91	38.93	18.93	62.7	100	0	P	H
		5110	54.57	-19.43	74	46.56	32.02	9.03	33.04	100	281	P	V
		5110	46.79	-7.21	54	38.78	32.02	9.03	33.04	100	281	A	V
		5806	59.75	-8.45	68.2	49.77	33.14	10.01	33.17	100	262	P	V
		6040	55.73	-12.47	68.2	45.3	33.65	10.06	33.28	100	262	P	V
		11160	54.98	-19.02	74	64.48	38.97	15.2	63.67	100	270	P	V
		11160	44.74	-9.26	54	54.24	38.97	15.2	63.67	100	270	A	V
		16740	44.33	-23.87	68.2	48.85	38.93	18.93	62.7	100	0	P	V



<b>802.11a CH 140 5700MHz</b>	5854	55.65	-12.55	68.2	45.55	33.27	10.02	33.19	100	255	P	H
	5932	54.94	-13.26	68.2	44.72	33.43	10.02	33.23	100	255	P	H
	11400	51.95	-22.05	74	60.85	38.64	15.38	63.2	100	187	P	H
	11400	44.08	-9.92	54	52.98	38.64	15.38	63.2	100	187	A	H
	17100	48.72	-19.48	68.2	50.35	40.84	19.18	62	100	0	P	H
	5854	60.19	-8.01	68.2	50.09	33.27	10.02	33.19	100	259	P	V
	5932	58.14	-10.06	68.2	47.92	33.43	10.02	33.23	100	259	P	V
	11400	52.49	-21.51	74	61.67	38.64	15.38	63.2	300	263	P	V
	11400	44.69	-9.31	54	53.87	38.64	15.38	63.2	300	263	A	V
	17100	48.01	-20.19	68.2	49.64	40.84	19.18	62	100	0	P	V
<b>Remark</b>	<ol style="list-style-type: none"> <li>No other spurious found.</li> <li>All results are PASS against Peak and Average limit line.</li> </ol>											



**Band 3 - 5470~5725MHz**  
**WIFI 802.11n HT20 (Band Edge @ 3m)**

WIFI Ant. 1+2	Note	Frequency ( MHz )	Level ( dBμV/m )	Over Limit ( dB )	Limit Line ( dBμV/m )	Read Level ( dBμV )	Antenna Factor ( dB/m )	Cable Loss ( dB )	Preamp Factor ( dB )	Ant Pos ( cm )	Table Pos ( deg )	Peak Avg. ( P/A )	Pol. ( H/V )
802.11n HT20 CH 100 5500MHz		5458.8	58.05	-15.95	74	49.43	32.35	9.29	33.02	100	239	P	H
		5469.52	67.57	-0.63	68.2	58.93	32.37	9.29	33.02	100	239	P	H
		5459.76	50.21	-3.79	54	41.59	32.35	9.29	33.02	100	239	A	H
	*	5500	115.55	-	-	106.8	32.4	9.37	33.02	100	239	P	H
	*	5500	108.38	-	-	99.63	32.4	9.37	33.02	100	239	A	H
		5449.68	60.27	-13.73	74	51.65	32.35	9.29	33.02	112	269	P	V
		5467.92	65.75	-2.45	68.2	57.11	32.37	9.29	33.02	112	269	P	V
		5460	51.32	-2.68	54	42.7	32.35	9.29	33.02	112	269	A	V
	*	5500	116.53	-	-	107.78	32.4	9.37	33.02	112	269	P	V
	*	5500	109.25	-	-	100.5	32.4	9.37	33.02	112	269	A	V
802.11n HT20 CH 116 5580MHz		5447.44	52.25	-21.75	74	43.63	32.35	9.29	33.02	207	251	P	H
		5463.52	51.94	-16.26	68.2	43.3	32.37	9.29	33.02	207	251	P	H
		5433.76	43.96	-10.04	54	35.39	32.33	9.26	33.02	207	251	A	H
	*	5580	115.52	-	-	106.54	32.57	9.48	33.07	207	251	P	H
	*	5580	108.05	-	-	99.07	32.57	9.48	33.07	207	251	A	H
		5736.965	53.22	-14.98	68.2	43.51	32.98	9.88	33.15	207	251	P	H
		5426.8	55.7	-18.3	74	47.14	32.32	9.26	33.02	100	262	P	V
		5462.8	54.1	-14.1	68.2	45.46	32.37	9.29	33.02	100	262	P	V
		5432.08	46.38	-7.62	54	37.81	32.33	9.26	33.02	100	262	A	V
	*	5580	116.49	-	-	107.51	32.57	9.48	33.07	100	262	P	V
*	5580	109.77	-	-	100.79	32.57	9.48	33.07	100	262	A	V	
		5732.24	59.82	-8.38	68.2	50.15	32.94	9.88	33.15	100	262	P	V



<b>802.11n</b>	*	5700	114.46	-	-	104.97	32.86	9.75	33.12	221	255	P	H
	*	5700	107.58	-	-	98.09	32.86	9.75	33.12	221	255	A	H
<b>HT20</b>		5725.48	66.8	-1.4	68.2	57.18	32.94	9.81	33.13	221	255	P	H
<b>CH 140</b>	*	5700	114.65	-	-	105.16	32.86	9.75	33.12	100	259	P	V
<b>5700MHz</b>	*	5700	107.85	-	-	98.36	32.86	9.75	33.12	100	259	A	V
		5725.48	67.55	-0.65	68.2	57.93	32.94	9.81	33.13	100	259	P	V
<b>Remark</b>	1. No other spurious found. 2. All results are PASS against Peak and Average limit line.												



**Band 3 - 5470~5725MHz**  
**WIFI 802.11n HT20 (Harmonic @ 3m)**

WIFI Ant. 1+2	Note	Frequency ( MHz )	Level ( dBµV/m )	Over Limit ( dB )	Limit Line ( dBµV/m )	Read Level (dBµV)	Antenna Factor ( dB/m )	Cable Loss ( dB )	Preamp Factor ( dB )	Ant Pos ( cm )	Table Pos ( deg )	Peak Avg. (P/A)	Pol. (H/V)
802.11n HT20 CH 100 5500MHz		5038	54.77	-19.23	74	46.89	31.95	8.97	33.04	100	239	P	H
		5038	45.02	-8.98	54	37.14	31.95	8.97	33.04	100	239	A	H
		5725	56.67	-11.53	68.2	47.05	32.94	9.81	33.13	100	239	P	H
		5956	56.31	-11.89	68.2	46.01	33.52	10.02	33.24	100	239	P	H
		11000	49.8	-24.2	74	59.22	39.2	15.08	64	100	0	P	H
		16500	47.59	-20.61	68.2	54.15	37.1	18.74	62.7	100	0	P	H
		5032	57.72	-16.28	74	49.86	31.93	8.97	33.04	112	293	P	V
		5032	47.86	-6.14	54	40	31.93	8.97	33.04	112	293	A	V
		5728	58.14	-10.06	68.2	48.52	32.94	9.81	33.13	112	269	P	V
		5956	56.16	-12.04	68.2	45.86	33.52	10.02	33.24	112	269	P	V
		11000	54.41	-19.59	74	64.13	39.2	15.08	64	100	279	P	V
		11000	44.51	-9.49	54	54.23	39.2	15.08	64	100	279	A	V
		16500	44.72	-23.48	68.2	51.28	37.1	18.74	62.7	100	0	P	V
802.11n HT20 CH 116 5580MHz		5728	54.72	-13.48	68.2	45.1	32.94	9.81	33.13	207	251	P	H
		5818	56.42	-11.78	68.2	46.44	33.14	10.02	33.18	207	251	P	H
		6046	55.18	-13.02	68.2	44.69	33.68	10.09	33.28	207	251	P	H
		11160	54.92	-19.08	74	64.13	38.97	15.2	63.67	100	318	P	H
		11160	45.02	-8.98	54	54.23	38.97	15.2	63.67	100	318	A	H
		16740	49.03	-19.17	68.2	53.55	38.93	18.93	62.7	100	0	P	H
		5728	60.7	-7.5	68.2	51.08	32.94	9.81	33.13	100	262	P	V
		5806	60.16	-8.04	68.2	50.18	33.14	10.01	33.17	100	262	P	V
		6058	54.72	-13.48	68.2	44.2	33.71	10.09	33.28	100	262	P	V
		11160	49.8	-24.2	74	59.3	38.97	15.2	63.67	100	0	P	V
	16740	47.31	-20.89	68.2	51.83	38.93	18.93	62.7	100	0	P	V	





<b>802.11n</b> <b>HT20</b> <b>CH 140</b> <b>5700MHz</b>		5224	52.93	-15.27	68.2	44.73	32.12	9.11	33.03	221	255	P	H
		5938	56.53	-11.67	68.2	46.32	33.43	10.02	33.24	221	255	P	H
		6178	56.1	-12.1	68.2	45.28	33.89	10.25	33.32	221	255	P	H
		11400	51.47	-22.53	74	60.37	38.64	15.38	63.2	100	186	P	H
		11400	41.79	-12.21	54	50.69	38.64	15.38	63.2	100	186	A	H
		17100	49.09	-19.11	68.2	50.72	40.84	19.18	62	100	0	P	H
		5224	53.3	-14.9	68.2	45.1	32.12	9.11	33.03	100	259	P	V
		5854	58.84	-9.36	68.2	48.74	33.27	10.02	33.19	100	259	P	V
		5938	57.87	-10.33	68.2	47.66	33.43	10.02	33.24	100	259	P	V
		11400	49.04	-24.96	74	58.22	38.64	15.38	63.2	100	0	P	V
		17100	48.31	-19.89	68.2	49.94	40.84	19.18	62	100	0	P	V
<b>Remark</b>	1. No other spurious found. 2. All results are PASS against Peak and Average limit line.												



**Band 3 - 5470~5725MHz**  
**WIFI 802.11n HT40 (Band Edge @ 3m)**

WIFI Ant. 1+2	Note	Frequency ( MHz )	Level ( dBµV/m )	Over Limit ( dB )	Limit Line ( dBµV/m )	Read Level ( dBµV )	Antenna Factor ( dB/m )	Cable Loss ( dB )	Preamp Factor ( dB )	Ant Pos ( cm )	Table Pos ( deg )	Peak Avg. ( P/A )	Pol. ( H/V )
802.11n HT40 CH 102 5510MHz		5451.76	58.64	-15.36	74	50.02	32.35	9.29	33.02	100	239	P	H
		5466.64	62.6	-5.6	68.2	53.96	32.37	9.29	33.02	100	239	P	H
		5458.96	49.95	-4.05	54	41.33	32.35	9.29	33.02	100	239	A	H
	*	5510	110.72	-	-	101.98	32.4	9.37	33.03	100	239	P	H
	*	5510	103.42	-	-	94.68	32.4	9.37	33.03	100	239	A	H
		5735.39	51.69	-16.51	68.2	41.98	32.98	9.88	33.15	100	239	P	H
		5459.68	58.74	-15.26	74	50.12	32.35	9.29	33.02	100	267	P	V
		5469.04	64.9	-3.3	68.2	56.26	32.37	9.29	33.02	100	267	P	V
		5458.24	51.88	-2.12	54	43.26	32.35	9.29	33.02	100	267	A	V
	*	5510	112.14	-	-	103.4	32.4	9.37	33.03	100	267	P	V
	*	5510	104.64	-	-	95.9	32.4	9.37	33.03	100	267	A	V
		5758.385	53.44	-14.76	68.2	43.63	33.02	9.95	33.16	100	267	P	V
802.11n HT40 CH 110 5550MHz		5454.4	55.76	-18.24	74	47.14	32.35	9.29	33.02	100	240	P	H
		5466.16	54.18	-14.02	68.2	45.54	32.37	9.29	33.02	100	240	P	H
		5459.92	44.93	-9.07	54	36.31	32.35	9.29	33.02	100	240	A	H
	*	5550	112.02	-	-	103.11	32.52	9.44	33.05	100	240	P	H
	*	5550	104.14	-	-	95.23	32.52	9.44	33.05	100	240	A	H
		5754.605	51.59	-16.61	68.2	41.84	33.02	9.88	33.15	100	240	P	H
		5448.16	54.37	-19.63	74	45.75	32.35	9.29	33.02	100	268	P	V
		5469.52	57.55	-10.65	68.2	48.91	32.37	9.29	33.02	100	268	P	V
		5459.92	46.43	-7.57	54	37.81	32.35	9.29	33.02	100	268	A	V
	*	5550	114.14	-	-	105.23	32.52	9.44	33.05	100	268	P	V
	*	5550	105.95	-	-	97.04	32.52	9.44	33.05	100	268	A	V
		5757.755	54.25	-13.95	68.2	44.44	33.02	9.95	33.16	100	268	P	V



<b>802.11n</b>  <b>HT40</b>  <b>CH 134</b>  <b>5670MHz</b>		5453.95	51.2	-22.8	74	42.58	32.35	9.29	33.02	100	254	P	H
		5460.95	50.13	-18.07	68.2	41.51	32.35	9.29	33.02	100	254	P	H
		5432.95	42.1	-11.9	54	33.53	32.33	9.26	33.02	100	254	A	H
	*	5670	112.06	-	-	102.68	32.81	9.68	33.11	100	254	P	H
	*	5670	104.53	-	-	95.15	32.81	9.68	33.11	100	254	A	H
		5728.95	63.43	-4.77	68.2	53.81	32.94	9.81	33.13	100	254	P	H
		5451.15	51.27	-22.73	74	42.65	32.35	9.29	33.02	100	263	P	V
		5462.7	51	-17.2	68.2	42.36	32.37	9.29	33.02	100	263	P	V
		5459.55	43.09	-10.91	54	34.47	32.35	9.29	33.02	100	263	A	V
	*	5670	113.99	-	-	104.61	32.81	9.68	33.11	100	263	P	V
	*	5670	106.18	-	-	96.8	32.81	9.68	33.11	100	263	A	V
		5731.225	67.48	-0.72	68.2	57.81	32.94	9.88	33.15	100	263	P	V
<b>Remark</b>	1. No other spurious found. 2. All results are PASS against Peak and Average limit line.												



**Band 3 - 5470~5725MHz**  
**WIFI 802.11n HT40 (Harmonic @ 3m)**

WIFI Ant. 1+2	Note	Frequency ( MHz )	Level ( dBμV/m )	Over Limit ( dB )	Limit Line ( dBμV/m )	Read Level ( dBμV )	Antenna Factor ( dB/m )	Cable Loss ( dB )	Preamp Factor ( dB )	Ant Pos ( cm )	Table Pos ( deg )	Peak Avg. (P/A)	Pol. (H/V)
802.11n HT40		11020	48.16	-25.84	74	57.55	39.18	15.11	63.97	100	0	P	H
		16530	41.77	-26.43	68.2	48.05	37.36	18.76	62.7	100	0	P	H
5510MHz CH 102		11020	48.07	-25.93	74	57.75	39.18	15.11	63.97	100	0	P	V
		16530	41.47	-26.73	68.2	47.75	37.36	18.76	62.7	100	0	P	V
802.11n HT40 CH 110		11100	49.77	-24.23	74	59.06	39.06	15.16	63.8	100	0	P	H
		16650	40.89	-27.31	68.2	46.14	38.28	18.86	62.7	100	0	P	H
		11100	48.29	-25.71	74	57.87	39.06	15.16	63.8	100	0	P	V
		16650	40.96	-27.24	68.2	46.21	38.28	18.86	62.7	100	0	P	V
802.11n HT40 CH 134		5806	55.47	-12.73	68.2	45.49	33.14	10.01	33.17	100	254	P	H
		11340	48.87	-25.13	74	57.85	38.73	15.33	63.33	100	0	P	H
		17010	48.77	-19.43	68.2	50.98	40.89	19.14	62.58	100	0	P	H
		5818	58.63	-9.57	68.2	48.65	33.14	10.02	33.18	100	263	P	V
		11340	49.49	-24.51	74	58.76	38.73	15.33	63.33	100	0	P	V
		17010	48.03	-20.17	68.2	50.24	40.89	19.14	62.58	100	0	P	V
Remark	1. No other spurious found. 2. All results are PASS against Peak and Average limit line.												



**Band 3 - 5470~5725MHz**  
**WIFI 802.11ac VHT80 (Band Edge @ 3m)**

WIFI Ant. 1+2	Note	Frequency ( MHz )	Level ( dBμV/m )	Over Limit ( dB )	Limit Line ( dBμV/m )	Read Level ( dBμV )	Antenna Factor ( dB/m )	Cable Loss ( dB )	Preamp Factor ( dB )	Ant Pos ( cm )	Table Pos ( deg )	Peak Avg. ( P/A )	Pol. ( H/V )
802.11ac VHT80 CH 106 5530MHz		5455.7	59.03	-14.97	74	50.41	32.35	9.29	33.02	100	238	P	H
		5469.35	58.28	-9.92	68.2	49.64	32.37	9.29	33.02	100	238	P	H
		5458.85	50.3	-3.7	54	41.68	32.35	9.29	33.02	100	238	A	H
	*	5530	107.99	-	-	99.19	32.44	9.41	33.05	100	238	P	H
	*	5530	99.82	-	-	91.02	32.44	9.41	33.05	100	238	A	H
		5747.99	51.88	-16.32	68.2	42.17	32.98	9.88	33.15	100	238	P	H
		5459.55	62.27	-11.73	74	53.65	32.35	9.29	33.02	100	270	P	V
		5462.7	62.55	-5.65	68.2	53.91	32.37	9.29	33.02	100	270	P	V
		5459.55	52.57	-1.43	54	43.95	32.35	9.29	33.02	100	270	A	V
	*	5530	109.3	-	-	100.5	32.44	9.41	33.05	100	270	P	V
	*	5530	101.38	-	-	92.58	32.44	9.41	33.05	100	270	A	V
		5750.825	51.79	-16.41	68.2	42.08	32.98	9.88	33.15	100	270	P	V
802.11ac VHT80 CH 122 5610MHz		5455.35	56.53	-17.47	74	47.91	32.35	9.29	33.02	100	241	P	H
		5467.95	56.15	-12.05	68.2	47.51	32.37	9.29	33.02	100	241	P	H
		5459.55	46.51	-7.49	54	37.89	32.35	9.29	33.02	100	241	A	H
	*	5610	109.17	-	-	100.05	32.65	9.55	33.08	100	241	P	H
	*	5610	100.89	-	-	91.77	32.65	9.55	33.08	100	241	A	H
		5736.65	60.67	-7.53	68.2	50.96	32.98	9.88	33.15	100	241	P	H
		5458.85	55.85	-18.15	74	47.23	32.35	9.29	33.02	100	270	P	V
		5469	58.84	-9.36	68.2	50.2	32.37	9.29	33.02	100	270	P	V
		5459.9	48.34	-5.66	54	39.72	32.35	9.29	33.02	100	270	A	V
	*	5610	111.33	-	-	102.21	32.65	9.55	33.08	100	270	P	V
*	5610	102.83	-	-	93.71	32.65	9.55	33.08	100	270	A	V	
	5735.425	65.11	-3.09	68.2	55.4	32.98	9.88	33.15	100	270	P	V	
Remark	1. No other spurious found. 2. All results are PASS against Peak and Average limit line.												



Band 3 5470~5725MHz

WIFI 802.11ac VHT80 (Harmonic @ 3m)

WIFI Ant. 1+2	Note	Frequency ( MHz )	Level ( dBμV/m )	Over Limit ( dB )	Limit Line ( dBμV/m )	Read Level (dBμV)	Antenna Factor ( dB/m )	Cable Loss ( dB )	Preamp Factor ( dB )	Ant Pos ( cm )	Table Pos ( deg )	Peak Avg. (P/A)	Pol. (H/V)
802.11ac		11060	46.46	-27.54	74	55.8	39.11	15.13	63.87	100	0	P	H
VHT80		16590	42.74	-25.46	68.2	48.57	37.76	18.81	62.7	100	0	P	H
CH 106		11060	45.41	-28.59	74	55.04	39.11	15.13	63.87	100	0	P	V
5530MHz		16590	42.13	-26.07	68.2	47.96	37.76	18.81	62.7	100	0	P	V
802.11ac		11220	48.99	-25.01	74	58.12	38.9	15.25	63.57	100	0	P	H
VHT80		16830	46.59	-21.61	68.2	50.37	39.59	19	62.7	100	0	P	H
CH 122		11220	46.71	-27.29	74	56.13	38.9	15.25	63.57	100	0	P	V
5610MHz		16830	46.19	-22.01	68.2	49.97	39.59	19	62.7	100	0	P	V
Remark	1. No other spurious found. 2. All results are PASS against Peak and Average limit line.												



Band 3 - Straddle Channel
WIFI 802.11a (Band Edge @ 3m)

Table with 14 columns: WIFI Ant., Note, Frequency, Level, Over Limit, Limit Line, Read Level, Antenna Factor, Cable Loss, Preamp Factor, Ant Pos, Table Pos, Peak Avg., Pol. It contains 4 rows of test data for 802.11a CH 144 and a Remark section.



Band 3 - Straddle Channel
WIFI 802.11a (Harmonic @ 3m)

Table with 14 columns: WIFI Ant. 1+2, Note, Frequency (MHz), Level (dBµV/m), Over Limit (dB), Limit Line (dBµV/m), Read Level (dBµV), Antenna Factor (dB/m), Cable Loss (dB), Preamp Factor (dB), Ant Pos (cm), Table Pos (deg), Peak Avg. (P/A), Pol. (H/V). Rows include data for 802.11a CH 144 (5720MHz) and a Remark section.





Band 3 - Straddle Channel
WIFI 802.11n HT20 (Band Edge @ 3m)

Table with 14 columns: WIFI Ant. 1+2, Note, Frequency (MHz), Level (dBµV/m), Over Limit (dB), Limit Line (dBµV/m), Read Level (dBµV), Antenna Factor (dB/m), Cable Loss (dB), Preamp Factor (dB), Ant Pos (cm), Table Pos (deg), Peak Avg. (P/A), Pol. (H/V). Rows include data for 802.11n HT20 CH 144 5720MHz and a Remark section.



**Band 3 - Straddle Channel**  
**WIFI 802.11n HT20 (Harmonic @ 3m)**

WIFI Ant. 1+2	Note	Frequency ( MHz )	Level ( dBμV/m )	Over Limit ( dB )	Limit Line ( dBμV/m )	Read Level (dBμV)	Antenna Factor ( dB/m )	Cable Loss ( dB )	Preamp Factor ( dB )	Ant Pos ( cm )	Table Pos ( deg )	Peak Avg. (P/A)	Pol. (H/V)
802.11n HT20 CH 144 5720MHz		5962	56.17	-12.03	68.2	45.89	33.52	10.02	33.26	233	255	P	H
		11440	54.62	-19.38	74	63.48	38.59	15.4	63.13	100	185	P	H
		11440	44.66	-9.34	54	53.52	38.59	15.4	63.13	100	185	A	H
		17160	48.8	-19.4	68.2	49.97	40.8	19.21	61.53	100	0	P	H
		5242	53.61	-14.59	68.2	45.37	32.15	9.12	33.03	100	265	P	V
		5866	61.25	-6.95	68.2	51.17	33.27	10.02	33.21	100	265	P	V
		5968	57.77	-10.43	68.2	47.48	33.52	10.03	33.26	100	265	P	V
		11440	54.42	-19.58	74	63.56	38.59	15.4	63.13	100	290	P	V
		11440	42.87	-11.13	54	52.01	38.59	15.4	63.13	100	290	A	V
		17160	48.73	-19.47	68.2	49.9	40.8	19.21	61.53	100	0	P	V
Remark	<ol style="list-style-type: none"> <li>No other spurious found.</li> <li>All results are PASS against Peak and Average limit line.</li> </ol>												



Band 3 - Straddle Channel
WIFI 802.11n HT40 (Band Edge @ 3m)

Table with 14 columns: WIFI Ant. 1+2, Note, Frequency (MHz), Level (dBµV/m), Over Limit (dB), Limit Line (dBµV/m), Read Level (dBµV), Antenna Factor (dB/m), Cable Loss (dB), Preamp Factor (dB), Ant Pos (cm), Table Pos (deg), Peak Avg. (P/A), Pol. (H/V). Rows include data for 802.11n, HT40, CH 142, and 5710MHz, plus a Remark section.



Band 3 - Straddle Channel
WIFI 802.11n HT40 (Harmonic @ 3m)

Table with 14 columns: WIFI Ant. 1+2, Note, Frequency (MHz), Level (dBµV/m), Over Limit (dB), Limit Line (dBµV/m), Read Level (dBµV), Antenna Factor (dB/m), Cable Loss (dB), Preamp Factor (dB), Ant Pos (cm), Table Pos (deg), Peak Avg. (P/A), Pol. (H/V). Rows include 802.11n, HT40, CH 142, 5710MHz, and a Remark section.



Band 3 - Straddle Channel
WIFI 802.11ac VHT80 (Band Edge @ 3m)

Table with 14 columns: WIFI Ant. 1+2, Note, Frequency (MHz), Level (dBµV/m), Over Limit (dB), Limit Line (dBµV/m), Read Level (dBµV), Antenna Factor (dB/m), Cable Loss (dB), Preamp Factor (dB), Ant Pos (cm), Table Pos (deg), Peak Avg. (P/A), Pol. (H/V). Rows include 802.11ac, VHT80, CH 138, 5690MHz and a Remark section.



Band 3 - Straddle Channel
WIFI 802.11ac VHT80 (Harmonic @ 3m)

Table with 14 columns: WIFI Ant. 1+2, Note, Frequency (MHz), Level (dBµV/m), Over Limit (dB), Limit Line (dBµV/m), Read Level (dBµV), Antenna Factor (dB/m), Cable Loss (dB), Preamp Factor (dB), Ant Pos (cm), Table Pos (deg), Peak Avg. (P/A), Pol. (H/V). Rows include 802.11ac, VHT80, CH 138, 5690MHz, and a Remark section.



Emission below 1GHz  
WIFI 802.11a (LF @ 3m)

WIFI Ant.	Note	Frequency	Level	Over Limit	Limit Line	Read Level	Antenna Factor	Cable Loss	Preamp Factor	Ant Pos	Table Pos	Peak Avg.	Pol.
1+2		( MHz )	( dBμV/m )	( dB )	( dBμV/m )	( dBμV )	( dB/m )	( dB )	( dB )	( cm )	( deg )	( P/A )	( H/V )
802.11a LF		129.09	28.33	-15.17	43.5	41.61	17.61	1.51	32.45	-	-	P	H
		150.69	29.2	-14.3	43.5	42.89	17.05	1.61	32.43	-	-	P	H
		192.54	26.24	-17.26	43.5	42.08	14.8	1.69	32.4	-	-	P	H
		340.6	28.86	-17.14	46	38.76	20.01	2.39	32.35	-	-	P	H
		633.9	28.42	-17.58	46	31.21	26.42	3.15	32.46	-	-	P	H
		958	33.83	-12.17	46	29.74	31.14	3.9	31.13	100	0	P	H
		39.45	26.5	-13.5	40	38.79	19.37	0.82	32.49	-	-	P	V
		73.47	24.97	-15.03	40	43.78	12.44	1.22	32.49	-	-	P	V
		190.92	29.09	-14.41	43.5	44.97	14.76	1.69	32.4	-	-	P	V
		467.3	27.19	-18.81	46	33.22	23.52	2.77	32.36	-	-	P	V
		751.5	30.93	-15.07	46	31.54	28.14	3.44	32.32	-	-	P	V
	955.9	33.21	-12.79	46	29.22	31.06	3.9	31.14	100	0	P	V	
Remark	1. No other spurious found. 2. All results are PASS against limit line.												



**Note symbol**

*	<b>Fundamental Frequency</b> which can be ignored. However, the level of any unwanted emissions shall not exceed the level of the fundamental frequency.
!	Test result is <b>over limit</b> line.
P/A	<b>Peak</b> or <b>Average</b>
H/V	<b>Horizontal</b> or <b>Vertical</b>





A calculation example for radiated spurious emission is shown as below:

WIFI	Note	Frequency	Level	Over	Limit	Read	Antenna	Cable	Preamp	Ant	Table	Peak	Pol.
Ant.				Limit	Line	Level	Factor	Loss	Factor	Pos	Pos	Avg.	
1+2		( MHz )	( dBμV/m )	( dB )	( dBμV/m )	( dBμV )	( dB/m )	( dB )	( dB )	( cm )	( deg )	( P/A )	( H/V )
802.11b		2390	55.45	-18.55	74	54.51	32.22	4.58	35.86	103	308	P	H
CH 01													
2412MHz		2390	43.54	-10.46	54	42.6	32.22	4.58	35.86	103	308	A	H

- Level(dBμV/m) =  
Antenna Factor(dB/m) + Cable Loss(dB) + Read Level(dBμV) - Preamp Factor(dB)
- Over Limit(dB) = Level(dBμV/m) – Limit Line(dBμV/m)

**For Peak Limit @ 2390MHz:**

- Level(dBμV/m)  
= Antenna Factor(dB/m) + Cable Loss(dB) + Read Level(dBμV) - Preamp Factor(dB)  
= 32.22(dB/m) + 4.58(dB) + 54.51(dBμV) – 35.86 (dB)  
= 55.45 (dBμV/m)
- Over Limit(dB)  
= Level(dBμV/m) – Limit Line(dBμV/m)  
= 55.45(dBμV/m) – 74(dBμV/m)  
= -18.55(dB)

**For Average Limit @ 2390MHz:**

- Level(dBμV/m)  
= Antenna Factor(dB/m) + Cable Loss(dB) + Read Level(dBμV) - Preamp Factor(dB)  
= 32.22(dB/m) + 4.58(dB) + 42.6(dBμV) – 35.86 (dB)  
= 43.54 (dBμV/m)
- Over Limit(dB)  
= Level(dBμV/m) – Limit Line(dBμV/m)  
= 43.54(dBμV/m) – 54(dBμV/m)  
= -10.46(dB)

Both peak and average measured complies with the limit line, so test result is “PASS”.



## Appendix D. Radiated Spurious Emission

Test Engineer :	J.C. Liang, Jacky Huang, Ken Wu	Temperature :	20~24°C
		Relative Humidity :	50~54%

### Note symbol

-L	Low channel location
-R	High channel location



**Band 1 - 5150~5250MHz**  
**WIFI 802.11a (Band Edge @ 3m)**

WIFI	Band 1 5150~5250MHz Band Edge @ 3m	
ANT	802.11a CH36 5180MHz	
1+2	Horizontal	Fundamental
<b>Peak</b>	<p>Site : 03CH11-HY            Condition : PEAK BE 74 3m HORN 9120D-HF HORIZONTAL</p>	<p>Site : 03CH11-HY            Condition : PEAK 74 3m HORN 9120D-HF HORIZONTAL</p>
<b>Avg.</b>	<p>Site : 03CH11-HY            Condition : AVG BE 54 3m HORN 9120D-HF HORIZONTAL</p>	<b>Left blank</b>

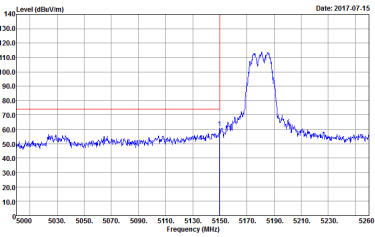
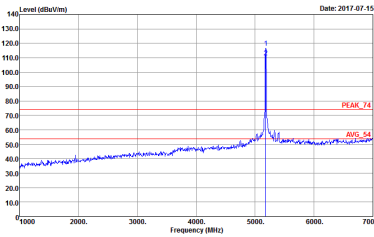
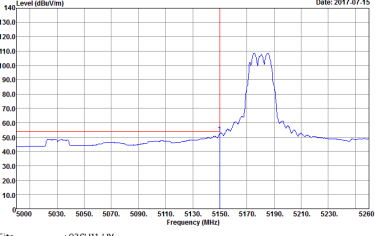

WIFI	Band 1 5150~5250MHz Band Edge @ 3m	
ANT	802.11a CH36 5180MHz	
1+2	Vertical	Fundamental
Peak	 <p>Site : 03CH11-HY Condition : PEAK BE 74 3m HORN 9120D-HF VERTICAL</p>	 <p>Site : 03CH11-HY Condition : PEAK 74 3m HORN 9120D-HF VERTICAL</p>
Avg.	 <p>Site : 03CH11-HY Condition : AVG BE 54 3m HORN 9120D-HF VERTICAL</p>	Left blank

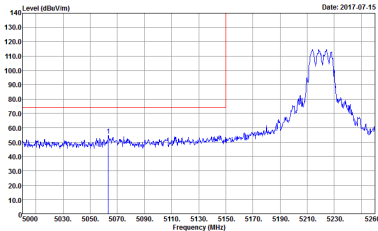
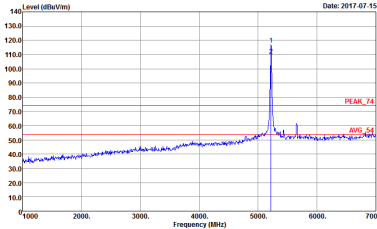
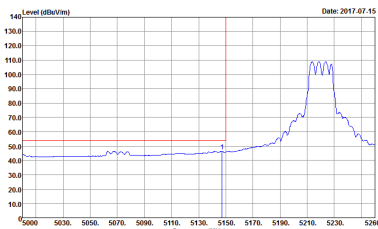

WIFI	Band 1 5150~5250MHz Band Edge @ 3m	
ANT	802.11a CH44 5220MHz - L	
1+2	Horizontal	Fundamental
<p><b>Peak</b></p>	 <p>Site : 03CH11-HY Condition : PEAK BE 74 3m HORN 9120D-HF HORIZONTAL</p>	 <p>Site : 03CH11-HY Condition : PEAK 74 3m HORN 9120D-HF HORIZONTAL</p>
<p><b>Avg.</b></p>	 <p>Site : 03CH11-HY Condition : AVG BE 54 3m HORN 9120D-HF HORIZONTAL</p>	<p>Left blank</p>



WIFI	Band 1 5150~5250MHz Band Edge @ 3m	
ANT	802.11a CH44 5220MHz - R	
1+2	Horizontal	Fundamental
Peak	<p>Site : 03CH11-HY Condition : PEAK_BE_74 3m HORN 91200-HF HORIZONTAL</p>	Left blank
Avg.	<p>Site : 03CH11-HY Condition : AVG_BE_54 3m HORN 91200-HF HORIZONTAL</p>	Left blank

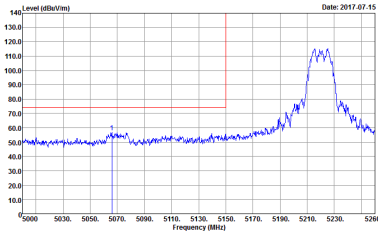
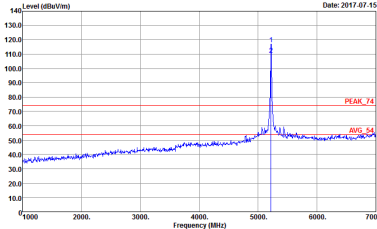
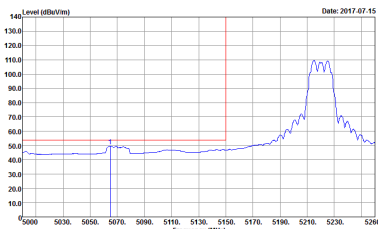

WIFI	Band 1 5150~5250MHz Band Edge @ 3m	
ANT	802.11a CH44 5220MHz - L	
1+2	Vertical	Fundamental
Peak	 <p>Site : 03CH11-HY Condition : PEAK BE 74 3m HORN 9120D-HF VERTICAL</p>	 <p>Site : 03CH11-HY Condition : PEAK 74 3m HORN 9120D-HF VERTICAL</p>
Avg.	 <p>Site : 03CH11-HY Condition : AVG BE 54 3m HORN 9120D-HF VERTICAL</p>	Left blank



WIFI	Band 1 5150~5250MHz Band Edge @ 3m	
ANT	802.11a CH44 5220MHz - R	
1+2	Vertical	Fundamental
<p><b>Peak</b></p>		<p>Left blank</p>
<p><b>Avg.</b></p>		<p>Left blank</p>





WIFI	Band 1 5150~5250MHz Band Edge @ 3m	
ANT	802.11a CH48 5240MHz - L	
1+2	Horizontal	Fundamental
<p><b>Peak</b></p>	<p>Site : 03CH11-HY Condition : PEAK BE 74 3m HORN 9120D-HF HORIZONTAL</p>	<p>Site : 03CH11-HY Condition : PEAK 74 3m HORN 9120D-HF HORIZONTAL</p>
<p><b>Avg.</b></p>	<p>Site : 03CH11-HY Condition : AVG BE 54 3m HORN 9120D-HF HORIZONTAL</p>	<p><b>Left blank</b></p>



WIFI	Band 1 5150~5250MHz Band Edge @ 3m	
ANT	802.11a CH48 5240MHz - R	
1+2	Horizontal	Fundamental
Peak	<p>Site : 03CH11-HY Condition : PEAK BE 74 3m HORN 91200-HF HORIZONTAL</p>	Left blank
Avg.	<p>Site : 03CH11-HY Condition : AVG BE 54 3m HORN 91200-HF HORIZONTAL</p>	Left blank



WIFI	Band 1 5150~5250MHz Band Edge @ 3m	
ANT	802.11a CH48 5240MHz - L	
1+2	Vertical	Fundamental
Peak	<p>Site : 03CH11-HY Condition : PEAK BE 74 3m HORN 9120D-HF VERTICAL</p>	<p>Site : 03CH11-HY Condition : PEAK 74 3m HORN 9120D-HF VERTICAL</p>
Avg.	<p>Site : 03CH11-HY Condition : AVG BE 54 3m HORN 9120D-HF VERTICAL</p>	Left blank



WIFI	Band 1 5150~5250MHz Band Edge @ 3m	
ANT	802.11a CH48 5240MHz - R	
1+2	Vertical	Fundamental
Peak	<p>Site : 03CH11-HY Condition : PEAK_BE 74 3m HORN 91200-HF VERTICAL</p>	Left blank
Avg.	<p>Site : 03CH11-HY Condition : AVG_BE 54 3m HORN 91200-HF VERTICAL</p>	Left blank



**Band 1 5150~5250MHz**  
**WIFI 802.11n HT20 (Band Edge @ 3m)**

WIFI	Band 1 5150~5250MHz Band Edge @ 3m	
ANT	802.11n HT20 CH36 5180MHz	
1+2	Horizontal	Fundamental
<b>Peak</b>		
<b>Avg.</b>		<b>Left blank</b>

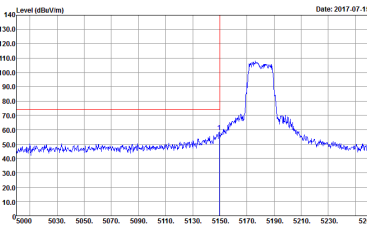
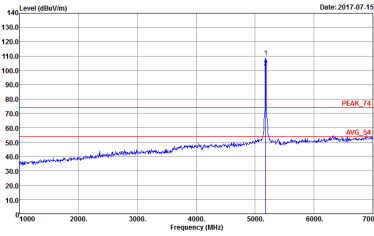
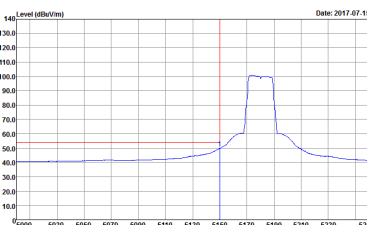

WIFI	Band 1 5150~5250MHz Band Edge @ 3m	
ANT	802.11n HT20 CH36 5180MHz	
1+2	Vertical	Fundamental
Peak	 <p>Site : 03CH11-HY Condition : PEAK BE 74 3m HORN 9120D-HF VERTICAL</p>	 <p>Site : 03CH11-HY Condition : PEAK 74 3m HORN 9120D-HF VERTICAL</p>
Avg.	 <p>Site : 03CH11-HY Condition : AVG BE 54 3m HORN 9120D-HF VERTICAL</p>	Left blank



WIFI	Band 1 5150~5250MHz Band Edge @ 3m	
ANT	802.11n HT20 CH44 5220MHz - L	
1+2	Horizontal	Fundamental
Peak	<p>Site : 03CH11-HY Condition : PEAK BE 74 3m HORN 9120D-HF HORIZONTAL</p>	<p>Site : 03CH11-HY Condition : PEAK 74 3m HORN 9120D-HF HORIZONTAL</p>
Avg.	<p>Site : 03CH11-HY Condition : AVG BE 54 3m HORN 9120D-HF HORIZONTAL</p>	Left blank



WIFI	Band 1 5150~5250MHz Band Edge @ 3m	
ANT	802.11n HT20 CH44 5220MHz - R	
1+2	Horizontal	Fundamental
<p><b>Peak</b></p>	<p>Site : 03CH11-HY Condition : PEAK_BE_74 3m HORN 91200-HF HORIZONTAL</p>	<p>Left blank</p>
<p><b>Avg.</b></p>	<p>Site : 03CH11-HY Condition : AVG_BE_54 3m HORN 91200-HF HORIZONTAL</p>	<p>Left blank</p>



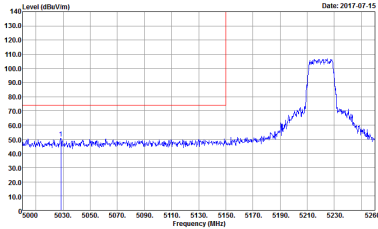
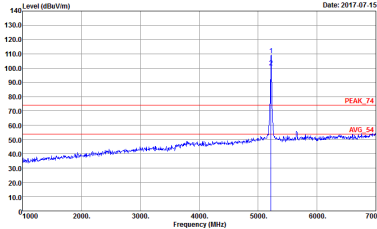
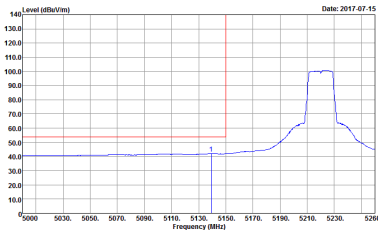

WIFI	Band 1 5150~5250MHz Band Edge @ 3m	
ANT	802.11n HT20 CH44 5220MHz - L	
1+2	Vertical	Fundamental
Peak	 <p>Site : 03CH11-HY Condition : PEAK BE 74 3m HORN 91200-HF VERTICAL</p>	 <p>Site : 03CH11-HY Condition : PEAK 74 3m HORN 91200-HF VERTICAL</p>
Avg.	 <p>Site : 03CH11-HY Condition : AVG BE 54 3m HORN 91200-HF VERTICAL</p>	Left blank



WIFI	Band 1 5150~5250MHz Band Edge @ 3m	
ANT	802.11n HT20 CH44 5220MHz - R	
1+2	Vertical	Fundamental
Peak	<p>Site : 03CH11-HY Condition : PEAK_BE_74 3m HORN 9120D-HF VERTICAL</p>	Left blank
Avg.	<p>Site : 03CH11-HY Condition : AVG_BE_54 3m HORN 9120D-HF VERTICAL</p>	Left blank

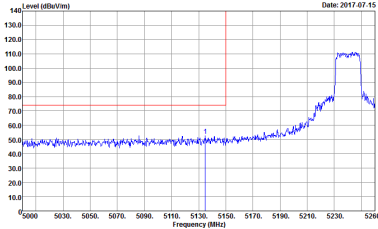
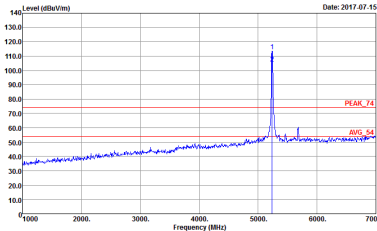
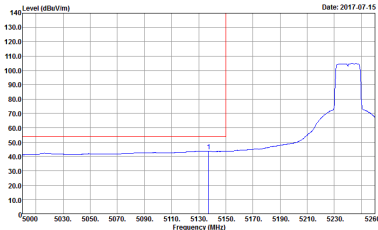

WIFI	Band 1 5150~5250MHz Band Edge @ 3m	
ANT	802.11n HT20 CH48 5240MHz - L	
1+2	Horizontal	Fundamental
Peak	 <p>Site : 03CH11-HY Condition : PEAK BE 74 3m HORN 9120D-HF HORIZONTAL</p>	 <p>Site : 03CH11-HY Condition : PEAK 74 3m HORN 9120D-HF HORIZONTAL</p>
Avg.	 <p>Site : 03CH11-HY Condition : AVG BE 54 3m HORN 9120D-HF HORIZONTAL</p>	Left blank



WIFI	Band 1 5150~5250MHz Band Edge @ 3m	
ANT	802.11n HT20 CH48 5240MHz - R	
1+2	Horizontal	Fundamental
Peak	<p>Site : 03CH11-HY Condition : PEAK BE 74 3m HORN 91200-HF HORIZONTAL</p>	Left blank
Avg.	<p>Site : 03CH11-HY Condition : AVG BE 54 3m HORN 91200-HF HORIZONTAL</p>	Left blank

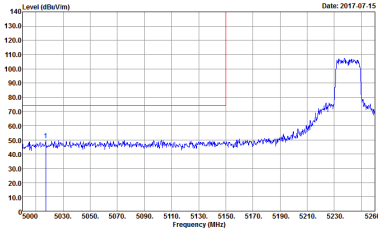
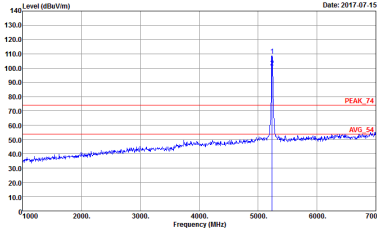
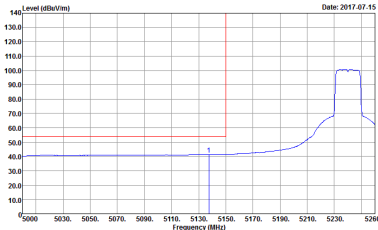

WIFI	Band 1 5150~5250MHz Band Edge @ 3m	
ANT	802.11n HT20 CH48 5240MHz - L	
1+2	Vertical	Fundamental
Peak	 <p>Site : 03CH11-HY Condition : PEAK BE 74 3m HORN 9120D-HF VERTICAL</p>	 <p>Site : 03CH11-HY Condition : PEAK 74 3m HORN 9120D-HF VERTICAL</p>
Avg.	 <p>Site : 03CH11-HY Condition : AVG BE 54 3m HORN 9120D-HF VERTICAL</p>	Left blank

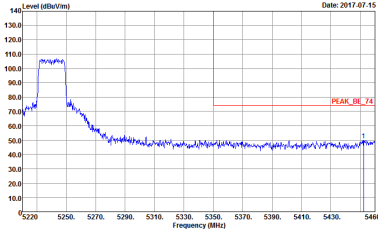
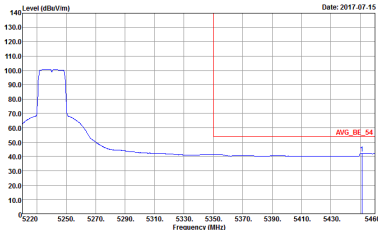

WIFI	Band 1 5150~5250MHz Band Edge @ 3m	
ANT	802.11n HT20 CH48 5240MHz - R	
1+2	Vertical	Fundamental
Peak	 <p>Site : 03CH11-HY Condition : PEAK_BE_74 3m HORN 91200-HF VERTICAL</p>	Left blank
Avg.	 <p>Site : 03CH11-HY Condition : AVG_BE_54 3m HORN 91200-HF VERTICAL</p>	Left blank



**Band 1 5150~5250MHz  
WIFI 802.11n HT40 (Band Edge @ 3m)**

WIFI	Band 1 5150~5250MHz Band Edge @ 3m	
ANT	802.11n HT40 CH38 5190MHz - L	
1+2	Horizontal	Fundamental
<b>Peak</b>	<p>Site : 03CH11-HY Condition : PEAK BE 74 3m HORN 9120D-HF HORIZONTAL</p>	<p>Site : 03CH11-HY Condition : PEAK 74 3m HORN 9120D-HF HORIZONTAL</p>
<b>Avg.</b>	<p>Site : 03CH11-HY Condition : AVG BE 54 3m HORN 9120D-HF HORIZONTAL</p>	<b>Left blank</b>

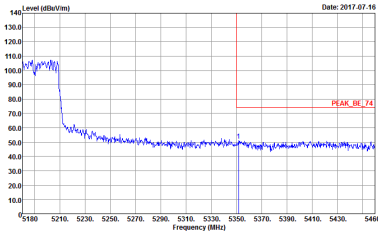
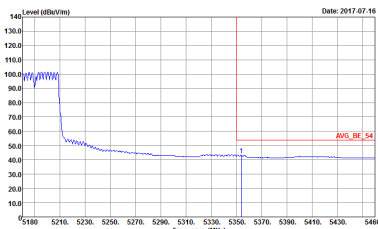

WIFI	Band 1 5150~5250MHz Band Edge @ 3m	
ANT	802.11n HT40 CH38 5190MHz - R	
1+2	Horizontal	Fundamental
<p><b>Peak</b></p>	 <p>Site : 03CH11-4FY Condition : PEAK_BE_74 3m HORN 91200-HF HORIZONTAL</p>	<p>Left blank</p>
<p><b>Avg.</b></p>	 <p>Site : 03CH11-4FY Condition : AVG_BE_54 3m HORN 91200-HF HORIZONTAL</p>	<p>Left blank</p>



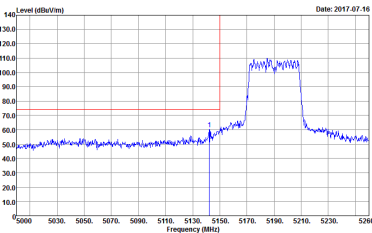
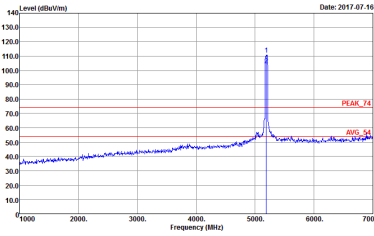
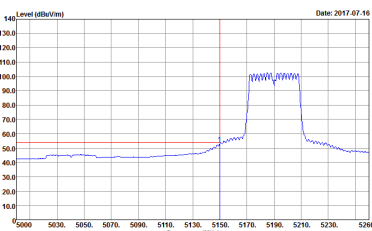

WIFI	Band 1 5150~5250MHz Band Edge @ 3m	
ANT	802.11n HT40 CH38 5190MHz - L	
1+2	Vertical	Fundamental
Peak	 <p>Site : 03CH11-HY Condition : PEAK BE 74 3m HORN 9120D-HF VERTICAL</p>	 <p>Site : 03CH11-HY Condition : PEAK 74 3m HORN 9120D-HF VERTICAL</p>
Avg.	 <p>Site : 03CH11-HY Condition : AVG BE 54 3m HORN 9120D-HF VERTICAL</p>	Left blank

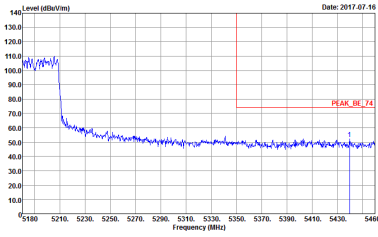
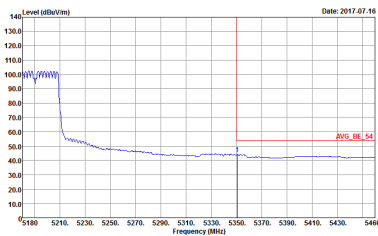

WIFI	Band 1 5150~5250MHz Band Edge @ 3m	
ANT	802.11n HT40 CH38 5190MHz - R	
1+2	Vertical	Fundamental
<p><b>Peak</b></p>	 <p>Site : 03CH11-HY Condition : PEAK_BE_74 3m HORN 91200-HF VERTICAL</p>	<p>Left blank</p>
<p><b>Avg.</b></p>	 <p>Site : 03CH11-HY Condition : AVG_BE_54 3m HORN 91200-HF VERTICAL</p>	<p>Left blank</p>



WIFI	Band 1 5150~5250MHz Band Edge @ 3m	
ANT	802.11n HT40 CH46 5230MHz - L	
1+2	Horizontal	Fundamental
<p><b>Peak</b></p>	<p>Site : 03CH11-HY Condition : PEAK BE 74 3m HORN 9120D-HF HORIZONTAL</p>	<p>Site : 03CH11-HY Condition : PEAK 74 3m HORN 9120D-HF HORIZONTAL</p>
<p><b>Avg.</b></p>	<p>Site : 03CH11-HY Condition : AVG BE 54 3m HORN 9120D-HF HORIZONTAL</p>	<p>Left blank</p>

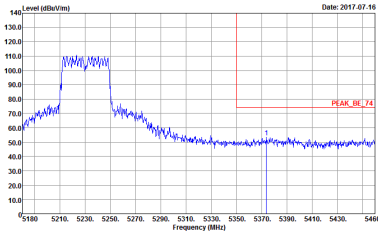
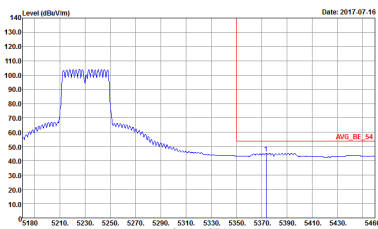

WIFI	Band 1 5150~5250MHz Band Edge @ 3m	
ANT	802.11n HT40 CH46 5230MHz - R	
1+2	Horizontal	Fundamental
<p><b>Peak</b></p>	 <p>Site : 03CH11-HY Condition : PEAK BE 74 3m HORN 91200-HF HORIZONTAL</p>	<p>Left blank</p>
<p><b>Avg.</b></p>	 <p>Site : 03CH11-HY Condition : AVG BE 54 3m HORN 91200-HF HORIZONTAL</p>	<p>Left blank</p>

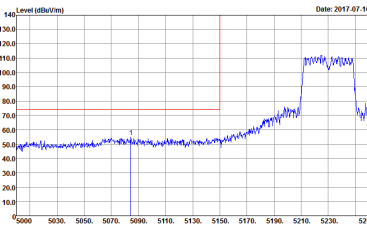
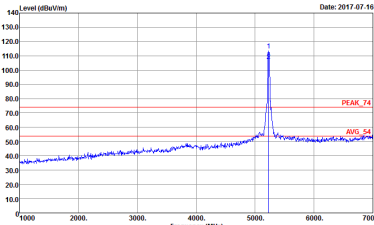
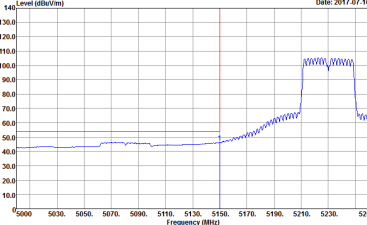

WIFI	Band 1 5150~5250MHz Band Edge @ 3m	
ANT	802.11n HT40 CH46 5230MHz - L	
1+2	Vertical	Fundamental
Peak	 <p>Site : 03CH11-HY Condition : PEAK BE 74 3m HORN 9120D-HF VERTICAL</p>	 <p>Site : 03CH11-HY Condition : PEAK 74 3m HORN 9120D-HF VERTICAL</p>
Avg.	 <p>Site : 03CH11-HY Condition : AVG BE 54 3m HORN 9120D-HF VERTICAL</p>	Left blank

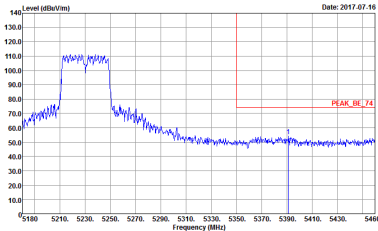
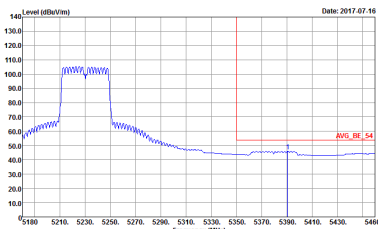

WIFI	Band 1 5150~5250MHz Band Edge @ 3m	
ANT	802.11n HT40 CH46 5230MHz - R	
1+2	Vertical	Fundamental
<p><b>Peak</b></p>	 <p>Site : 03CH11-HY Condition : PEAK BE 74 3m HORN 91200-HF VERTICAL</p>	<p>Left blank</p>
<p><b>Avg.</b></p>	 <p>Site : 03CH11-HY Condition : AVG BE 54 3m HORN 91200-HF VERTICAL</p>	<p>Left blank</p>



Band 1 5150~5250MHz
WIFI 802.11ac VHT80 (Band Edge @ 3m)

Table with 2 columns (Horizontal, Fundamental) and 2 rows (Peak, Avg.). Contains spectral plots and labels like 'Peak', 'Fundamental', 'Avg.', and 'Left blank'. Includes site and condition details for each plot.

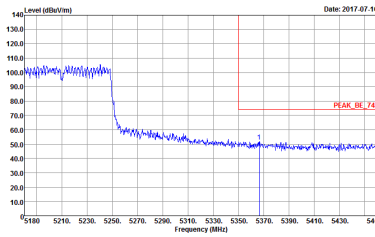
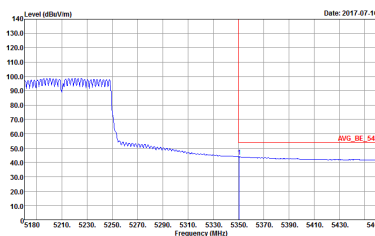

WIFI	Band 1 5150~5250MHz Band Edge @ 3m	
ANT	802.11ac VHT80 CH42 5210MHz - R	
1+2	Horizontal	Fundamental
<p><b>Peak</b></p>	 <p>Site : 03CH11-HY Condition : PEAK_BE_74 3m HORN 9120D-HF HORIZONTAL</p>	<p>Left blank</p>
<p><b>Avg.</b></p>	 <p>Site : 03CH11-HY Condition : AVG_BE_54 3m HORN 9120D-HF HORIZONTAL</p>	<p>Left blank</p>



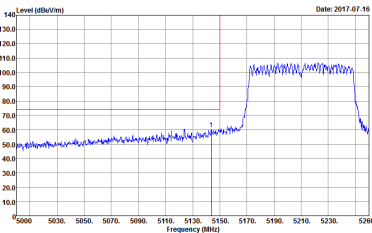
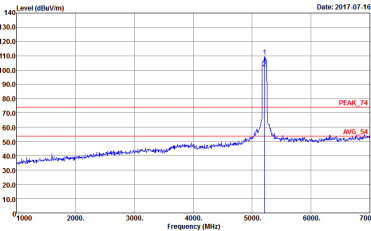
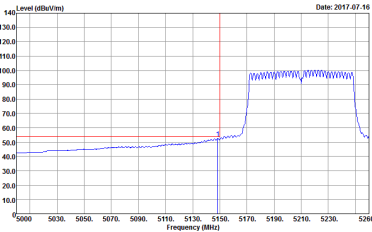

WIFI	Band 1 5150~5250MHz Band Edge @ 3m	
ANT	802.11ac VHT80 CH42 5210MHz - L	
1+2	Vertical	Fundamental
Peak	 <p>Site : 03CH11-HY Condition : PEAK BE 74 3m HORN 9120D-HF VERTICAL</p>	 <p>Site : 03CH11-HY Condition : PEAK 74 3m HORN 9120D-HF VERTICAL</p>
Avg.	 <p>Site : 03CH11-HY Condition : AVG BE 54 3m HORN 9120D-HF VERTICAL</p>	Left blank



WIFI	Band 1 5150~5250MHz Band Edge @ 3m	
ANT	802.11ac VHT80 CH42 5210MHz - R	
1+2	Vertical	Fundamental
Peak	<p>Site : 03CH11-HY Condition : PEAK BE 74 3m HORN 91200-HF VERTICAL</p>	Left blank
Avg.	<p>Site : 03CH11-HY Condition : AVG BE 54 3m HORN 91200-HF VERTICAL</p>	Left blank



Band 1 - 5150~5250MHz  
WIFI 802.11a (Harmonic @ 3m)

WIFI	Band 1 5150~5250MHz Harmonic @ 3m	
ANT	802.11a CH36 5180MHz	
1+2	Horizontal	Vertical
Peak Avg.	<p>Site : 03CH11-14Y Condition : PEAK(LINE1) 3m 9170 SHF HORM 150809 HORIZONTAL</p>	<p>Site : 03CH11-14Y Condition : PEAK(LINE1) 3m 9170 SHF HORM 150809 VERTICAL</p>



WIFI	Band 1 5150~5250MHz Harmonic @ 3m	
ANT	802.11a CH44 5220MHz	
1+2	Horizontal	Vertical
Peak Avg.	<p>Site : 03CH11-HY Condition : PEAK(UNII) 3m 9170 SHF HORM 150809 HORIZONTAL</p>	<p>Site : 03CH11-HY Condition : PEAK(UNII) 3m 9170 SHF HORM 150809 VERTICAL</p>

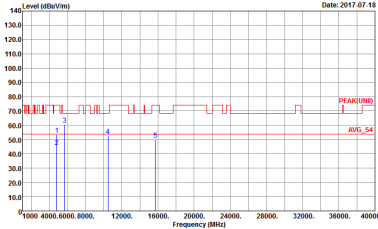
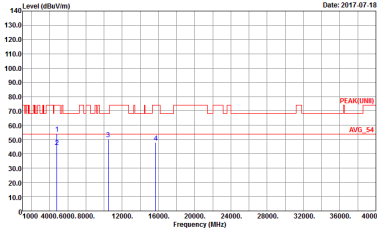

WIFI	Band 1 5150~5250MHz Harmonic @ 3m	
ANT	802.11a CH48 5240MHz	
1+2	Horizontal	Vertical
<p>Peak Avg.</p>	 <p>Site : 03CH11-HY Condition : PEAK(UNII) 3m 9170 SHF HORM 150809 HORIZONTAL</p>	 <p>Site : 03CH11-HY Condition : PEAK(UNII) 3m 9170 SHF HORM 150809 VERTICAL</p>



Band 1 5150~5250MHz  
WIFI 802.11n HT20 (Harmonic @ 3m)

WIFI	Band 1 5150~5250MHz Harmonic @ 3m	
ANT	802.11n HT20 CH36 5180MHz	
1+2	Horizontal	Vertical
Peak Avg.	<p>Site : 03CH11-HY Condition : PEAK(UNEI) 3m 9170 SHF HORM 150809 HORIZONTAL</p>	<p>Site : 03CH11-HY Condition : PEAK(UNEI) 3m 9170 SHF HORM 150809 VERTICAL</p>



WIFI	Band 1 5150~5250MHz Harmonic @ 3m	
ANT	802.11n HT20 CH44 5220MHz	
1+2	Horizontal	Vertical
Peak Avg.	<p>Site : 03CH11-HY Condition : PEAK(UNII) 3m 9170 SHF HORM 150809 HORIZONTAL</p>	<p>Site : 03CH11-HY Condition : PEAK(UNII) 3m 9170 SHF HORM 150809 VERTICAL</p>



WIFI	Band 1 5150~5250MHz Harmonic @ 3m	
ANT	802.11n HT20 CH48 5240MHz	
1+2	Horizontal	Vertical
Peak Avg.	<p>Site : 03CH11-HY Condition : PEAKUNII1 3m 9170 SHF HORM 150809 HORIZONTAL</p>	<p>Site : 03CH11-HY Condition : PEAKUNII1 3m 9170 SHF HORM 150809 VERTICAL</p>





**Band 1 5150~5250MHz  
WIFI 802.11n HT40 (Harmonic @ 3m)**

<b>WIFI</b>	<b>Band 1 5150~5250MHz Harmonic @ 3m</b>	
<b>ANT</b>	<b>802.11n HT40 CH38 5190MHz</b>	
<b>1+2</b>	<b>Horizontal</b>	<b>Vertical</b>
<b>Peak Avg.</b>	<p>Site : 03CH11-HY Condition : PEAK 74 3m 9170 5HF HORM 150809 HORIZONTAL</p>	<p>Site : 03CH11-HY Condition : PEAK 74 3m 9170 5HF HORM 150809 VERTICAL</p>



WIFI	Band 1 5150~5250MHz Harmonic @ 3m	
ANT	802.11n HT40 CH46 5230MHz	
1+2	Horizontal	Vertical
Peak Avg.	<p>Site : 03CH11-HY Condition : PEAK 74 3m 9170 5HF HORM 150809 HORIZONTAL</p>	<p>Site : 03CH11-HY Condition : PEAK 74 3m 9170 5HF HORM 150809 VERTICAL</p>



**Band 1 5150~5250MHz  
WIFI 802.11ac VHT80 (Harmonic @ 3m)**

<b>WIFI</b>	<b>Band 1 5150~5250MHz Harmonic @ 3m</b>	
<b>ANT</b>	<b>802.11ac VHT80 CH42 5210MHz</b>	
<b>1+2</b>	<b>Horizontal</b>	<b>Vertical</b>
<b>Peak Avg.</b>	<p>Site : 03CH11-HY Condition : PEAK 74 3m 9170 5HF HORM 150809 HORIZONTAL</p>	<p>Site : 03CH11-HY Condition : PEAK 74 3m 9170 5HF HORM 150809 VERTICAL</p>



**Band 2 - 5250~5350MHz**  
**WIFI 802.11a (Band Edge @ 3m)**

WIFI	Band 2 5250~5350MHz Band Edge @ 3m	
ANT	802.11a CH52 5260MHz - L	
1+2	Horizontal	Fundamental
<p><b>Peak</b></p>		
<p><b>Avg.</b></p>		<p align="center"><b>Left blank</b></p>



WIFI	Band 2 5250~5350MHz Band Edge @ 3m	
ANT	802.11a CH52 5260MHz - R	
1+2	Horizontal	Fundamental
Peak		Left blank
Avg.		Left blank

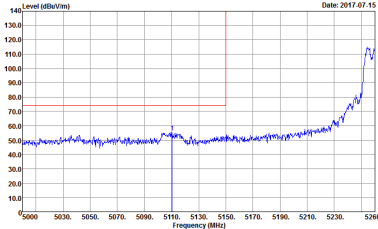
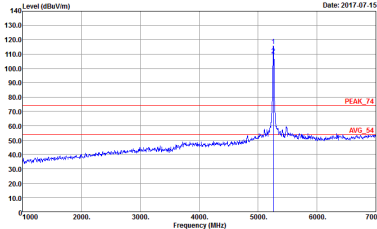
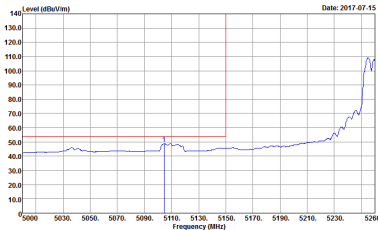

WIFI	Band 2 5250~5350MHz Band Edge @ 3m	
ANT	802.11a CH52 5260MHz - L	
1+2	Vertical	Fundamental
Peak	 <p>Site : 03CH11-HY Condition : PEAK BE 74 3m HORN 9120D-HF VERTICAL</p>	 <p>Site : 03CH11-HY Condition : PEAK 74 3m HORN 9120D-HF VERTICAL</p>
Avg.	 <p>Site : 03CH11-HY Condition : AVG BE 54 3m HORN 9120D-HF VERTICAL</p>	Left blank



WIFI	Band 2 5250~5350MHz Band Edge @ 3m	
ANT	802.11a CH52 5260MHz - R	
1+2	Vertical	Fundamental
<p><b>Peak</b></p>		<p>Left blank</p>
<p><b>Avg.</b></p>		<p>Left blank</p>

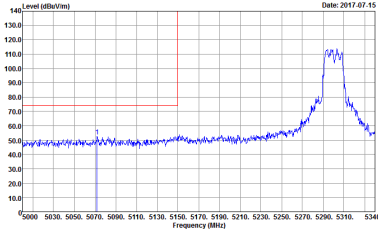
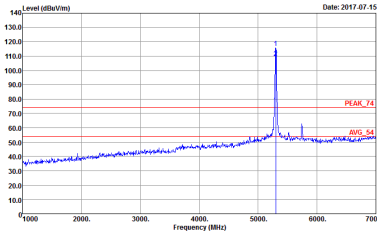
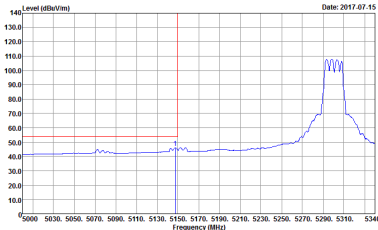

WIFI	Band 2 5250~5350MHz Band Edge @ 3m	
ANT	802.11a CH60 5300MHz - L	
1+2	Horizontal	Fundamental
Peak	 <p>Site : 03CH11-HY Condition : PEAK BE 74 3m HORN 9120D-HF HORIZONTAL</p>	 <p>Site : 03CH11-HY Condition : PEAK 74 3m HORN 9120D-HF HORIZONTAL</p>
Avg.	 <p>Site : 03CH11-HY Condition : AVG BE 54 3m HORN 9120D-HF HORIZONTAL</p>	Left blank





WIFI	Band 2 5250~5350MHz Band Edge @ 3m	
ANT	802.11a CH60 5300MHz - R	
1+2	Horizontal	Fundamental
<p><b>Peak</b></p>		<p>Left blank</p>
<p><b>Avg.</b></p>		<p>Left blank</p>

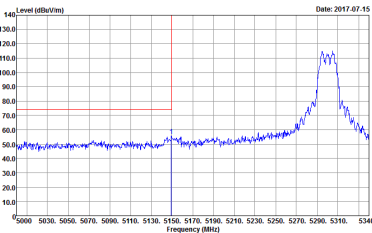
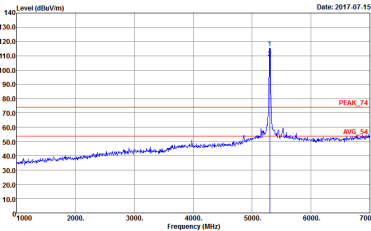
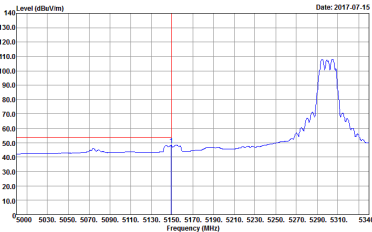

WIFI	Band 2 5250~5350MHz Band Edge @ 3m	
ANT	802.11a CH60 5300MHz - L	
1+2	Vertical	Fundamental
Peak	 <p>Site : 03CH11-HY Condition : PEAK BE 74 3m HORN 9120D-HF VERTICAL</p>	 <p>Site : 03CH11-HY Condition : PEAK 74 3m HORN 9120D-HF VERTICAL</p>
Avg.	 <p>Site : 03CH11-HY Condition : AVG BE 54 3m HORN 9120D-HF VERTICAL</p>	Left blank



WIFI	Band 2 5250~5350MHz Band Edge @ 3m	
ANT	802.11a CH60 5300MHz - R	
1+2	Vertical	Fundamental
<p><b>Peak</b></p>	<p>Site : 03CH11-HY Condition : PEAK BE 74 3m HORN 91200-HF VERTICAL</p>	<p>Left blank</p>
<p><b>Avg.</b></p>	<p>Site : 03CH11-HY Condition : AVG BE 54 3m HORN 91200-HF VERTICAL</p>	<p>Left blank</p>



WIFI	Band 2 5250~5350MHz Band Edge @ 3m	
ANT	802.11a CH64 5320MHz	
1+2	Horizontal	Fundamental
Peak	<p>Site : 03CH11-HY Condition : PEAK BE 74 3m HORN 9120D-HF HORIZONTAL</p>	<p>Site : 03CH11-HY Condition : PEAK 74 3m HORN 9120D-HF HORIZONTAL</p>
Avg.	<p>Site : 03CH11-HY Condition : AVG BE 54 3m HORN 9120D-HF HORIZONTAL</p>	Left blank

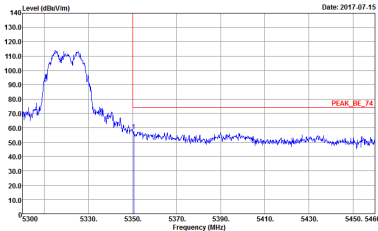
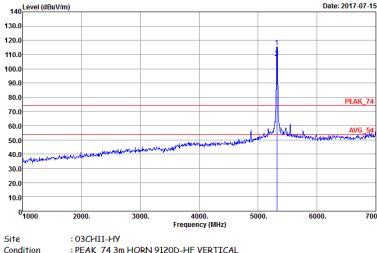
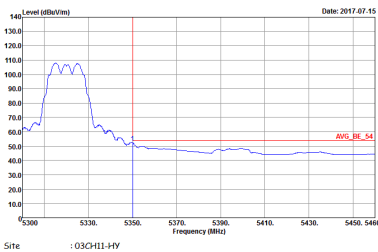

WIFI	Band 2 5250~5350MHz Band Edge @ 3m	
ANT	802.11a CH64 5320MHz	
1+2	Vertical	Fundamental
<p><b>Peak</b></p>	 <p>Site : 03CH11-HY Condition : PEAK_BE_74 3m HORN 9120D-HF VERTICAL</p>	 <p>Site : 03CH11-HY Condition : PEAK_74 3m HORN 9120D-HF VERTICAL</p>
<p><b>Avg.</b></p>	 <p>Site : 03CH11-HY Condition : AVG_BE_54 3m HORN 9120D-HF VERTICAL</p>	<p>Left blank</p>

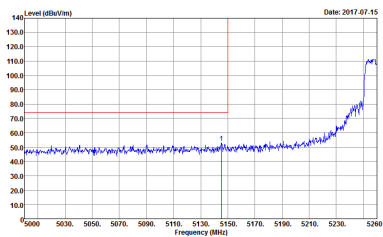
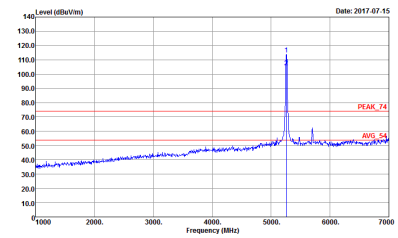
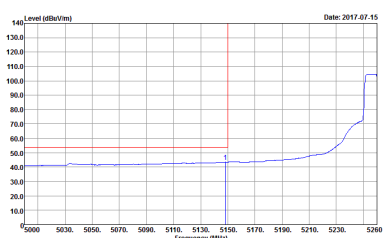

**Band 2 5250~5350MHz**  
**WIFI 802.11n HT20 (Band Edge @ 3m)**

WIFI	Band 2 5250~5350MHz Band Edge @ 3m	
ANT	802.11n HT20 CH52 5260MHz - L	
1+2	Horizontal	Fundamental
<b>Peak</b>	 <p>Site : 03CH11-HY            Condition : PEAK BE 74 3m HORN 9120D-HF HORIZONTAL</p>	 <p>Site : 03CH11-HY            Condition : PEAK 74 3m HORN 9120D-HF HORIZONTAL</p>
<b>Avg.</b>	 <p>Site : 03CH11-HY            Condition : AV6 BE 54 3m HORN 9120D-HF HORIZONTAL</p>	<b>Left blank</b>



WIFI	Band 2 5250~5350MHz Band Edge @ 3m	
ANT	802.11n HT20 CH52 5260MHz - R	
1+2	Horizontal	Fundamental
Peak	<p>Site : 03CH11-HY Condition : PEAK_BE_74 3m HORN 91200-HF HORIZONTAL</p>	Left blank
Avg.	<p>Site : 03CH11-HY Condition : AVG_BE_54 3m HORN 91200-HF HORIZONTAL</p>	Left blank

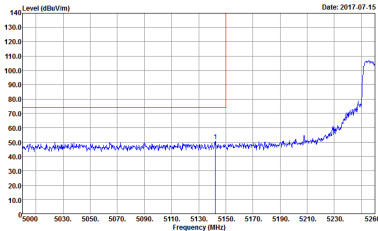
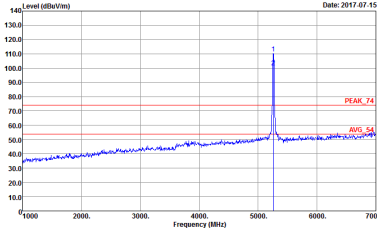
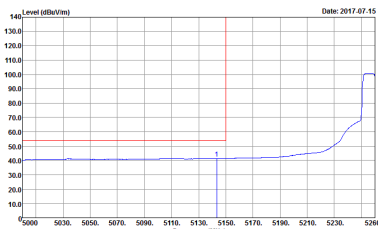

WIFI	Band 2 5250~5350MHz Band Edge @ 3m	
ANT	802.11n HT20 CH52 5260MHz - L	
1+2	Vertical	Fundamental
Peak	 <p>Site : 03CH11-HY Condition : PEAK BE 74 3m HORN 9120D-HF VERTICAL</p>	 <p>Site : 03CH11-HY Condition : PEAK 74 3m HORN 9120D-HF VERTICAL</p>
Avg.	 <p>Site : 03CH11-HY Condition : AVG BE 54 3m HORN 9120D-HF VERTICAL</p>	Left blank



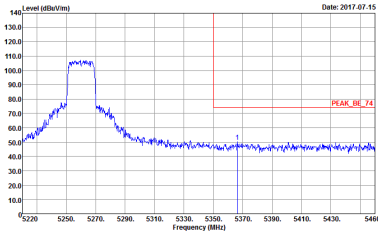
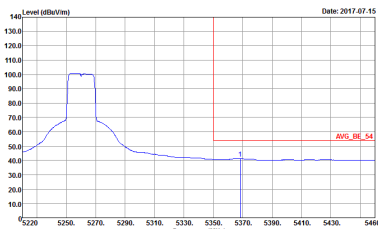

WIFI	Band 2 5250~5350MHz Band Edge @ 3m	
ANT	802.11n HT20 CH52 5260MHz - R	
1+2	Vertical	Fundamental
<p><b>Peak</b></p>	 <p>Site : 03CH11-HY Condition : PEAK_BE_74 3m HORN 91200-HF VERTICAL</p>	<p>Left blank</p>
<p><b>Avg.</b></p>	 <p>Site : 03CH11-HY Condition : AVG_BE_54 3m HORN 91200-HF VERTICAL</p>	<p>Left blank</p>

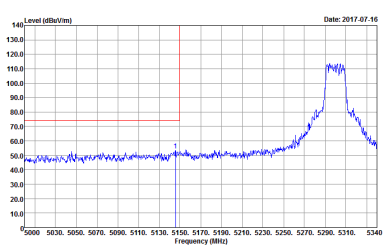
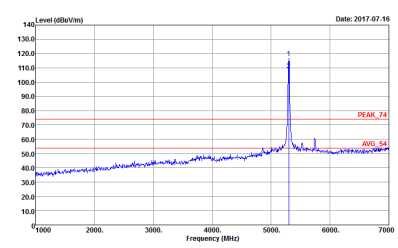
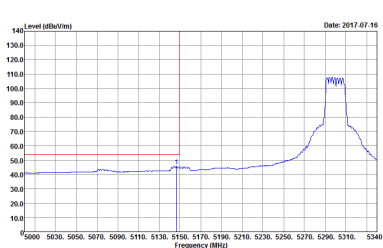

WIFI	Band 2 5250~5350MHz Band Edge @ 3m	
ANT	802.11n HT20 CH60 5300MHz - L	
1+2	Horizontal	Fundamental
<p><b>Peak</b></p>	 <p>Site : 03CH11-HY Condition : PEAK BE 74 3m HORN 9120D-HF HORIZONTAL</p>	 <p>Site : 03CH11-HY Condition : PEAK 74 3m HORN 9120D-HF HORIZONTAL</p>
<p><b>Avg.</b></p>	 <p>Site : 03CH11-HY Condition : AVG BE 54 3m HORN 9120D-HF HORIZONTAL</p>	<p>Left blank</p>

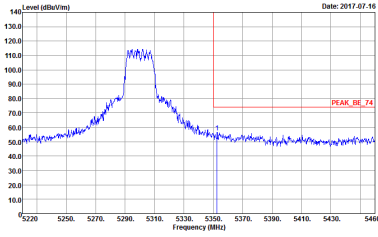
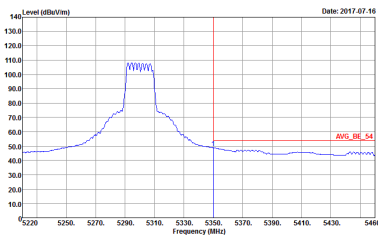

WIFI	Band 2 5250~5350MHz Band Edge @ 3m	
ANT	802.11n HT20 CH60 5300MHz - R	
1+2	Horizontal	Vertical
<p><b>Peak</b></p>	 <p>Site : 03CH11-HY Condition : PEAK_BE_74 3m HORN 91200-HF HORIZONTAL</p>	<p>Left blank</p>
<p><b>Avg.</b></p>	 <p>Site : 03CH11-HY Condition : AVG_BE_54 3m HORN 91200-HF HORIZONTAL</p>	<p>Left blank</p>

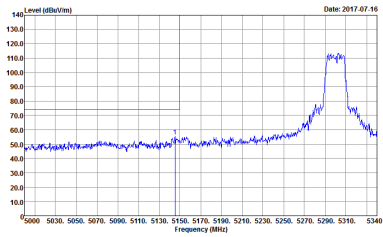
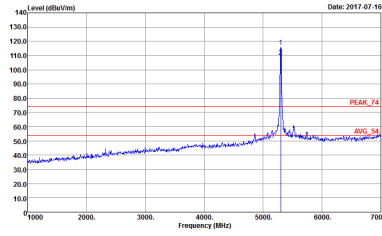
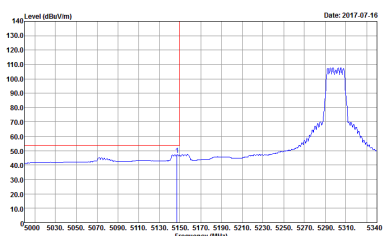

WIFI	Band 2 5250~5350MHz Band Edge @ 3m	
ANT	802.11n HT20 CH60 5300MHz - L	
1+2	Vertical	Fundamental
Peak	 <p>Site : 03CH11-HY Condition : PEAK BE 74 3m HORN 9120D-HF VERTICAL</p>	 <p>Site : 03CH11-HY Condition : PEAK 74 3m HORN 9120D-HF VERTICAL</p>
Avg.	 <p>Site : 03CH11-HY Condition : AVG 54 3m HORN 9120D-HF VERTICAL</p>	Left blank



WIFI	Band 2 5250~5350MHz Band Edge @ 3m	
ANT	802.11n HT20 CH60 5300MHz - R	
1+2	Vertical	Fundamental
<p><b>Peak</b></p>		<p>Left blank</p>
<p><b>Avg.</b></p>		<p>Left blank</p>



WIFI	Band 2 5250~5350MHz Band Edge @ 3m	
ANT	802.11n HT20 CH64 5320MHz	
1+2	Horizontal	Fundamental
Peak	<p>Site : 03CH11-HY Condition : PEAK BE 74 3m HORN 9120D-HF HORIZONTAL</p>	<p>Site : 03CH11-HY Condition : PEAK 74 3m HORN 9120D-HF HORIZONTAL</p>
Avg.	<p>Site : 03CH11-HY Condition : AVG BE 54 3m HORN 9120D-HF HORIZONTAL</p>	Left blank

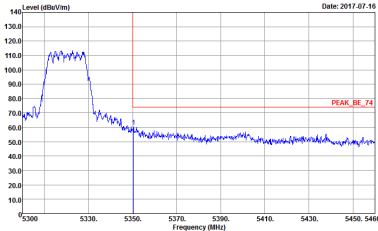
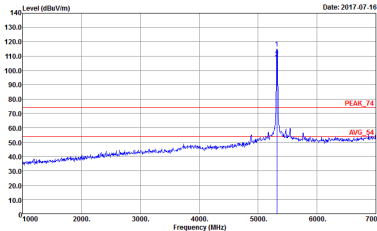
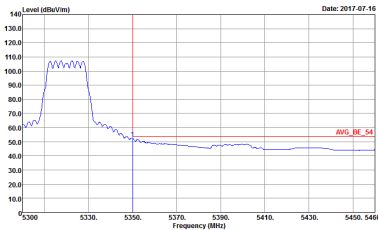

WIFI	Band 2 5250~5350MHz Band Edge @ 3m	
ANT	802.11n HT20 CH64 5320MHz	
1+2	Vertical	Fundamental
<p><b>Peak</b></p>	 <p>Site : 03CH11-HY Condition : PEAK_BE 74 3m HORN 9120D-HF VERTICAL</p>	 <p>Site : 03CH11-HY Condition : PEAK_F1 3m HORN 9120D-HF VERTICAL</p>
<p><b>Avg.</b></p>	 <p>Site : 03CH11-HY Condition : AVG_BE 54 3m HORN 9120D-HF VERTICAL</p>	<p>Left blank</p>



**Band 2 5250~5350MHz**  
**WIFI 802.11n HT40 (Band Edge @ 3m)**

WIFI	Band 2 5250~5350MHz Band Edge @ 3m	
ANT	802.11n HT40 CH54 5270 MHz - L	
1+2	Horizontal	Fundamental
<b>Peak</b>		
<b>Avg.</b>		<b>Left blank</b>





WIFI	Band 2 5250~5350MHz Band Edge @ 3m	
ANT	802.11n HT40 CH54 5270 MHz - R	
1+2	Horizontal	Fundamental
Peak	<p>Site : 03CH11-HY Condition : PEAK BE 74 3m HORN 91200-HF HORIZONTAL</p>	Left blank
Avg.	<p>Site : 03CH11-HY Condition : AVG BE 54 3m HORN 91200-HF HORIZONTAL</p>	Left blank

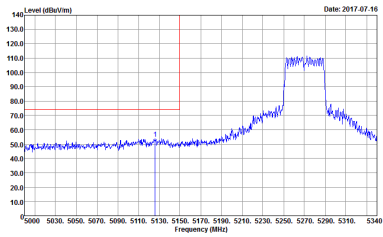
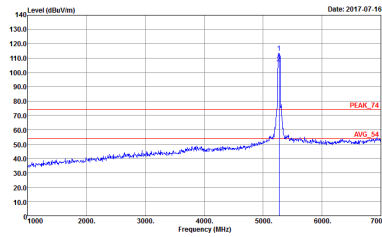
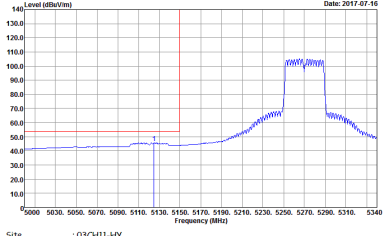

WIFI	Band 2 5250~5350MHz Band Edge @ 3m	
ANT	802.11n HT40 CH54 5270 MHz - L	
1+2	Vertical	Vertical
Peak	 <p>Site : 03CH11-HY Condition : PEAK BE 74 3m HORN 9120D-HF VERTICAL</p>	 <p>Site : 03CH11-HY Condition : PEAK 74 3m HORN 9120D-HF VERTICAL</p>
Avg.	 <p>Site : 03CH11-HY Condition : AVG BE 54 3m HORN 9120D-HF VERTICAL</p>	Left blank



WIFI	Band 2 5250~5350MHz Band Edge @ 3m	
ANT	802.11n HT40 CH54 5270 MHz - R	
1+2	Vertical	Vertical
Peak	<p>Site : 03CH11-HY Condition : PEAK BE 74 3m HORN 91200-HF VERTICAL</p>	Left blank
Avg.	<p>Site : 03CH11-HY Condition : AVG BE 54 3m HORN 91200-HF VERTICAL</p>	Left blank



WIFI	Band 2 5250~5350MHz Band Edge @ 3m	
ANT	802.11n HT40 CH62 5310 MHz - L	
1+2	Horizontal	Fundamental
Peak		
Avg.		Left blank

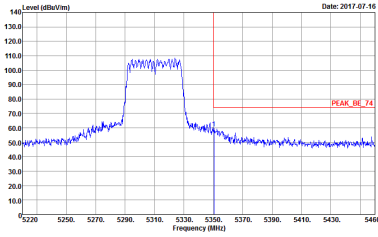
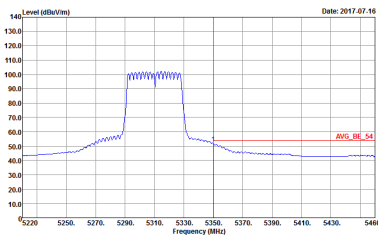

WIFI	Band 2 5250~5350MHz Band Edge @ 3m	
ANT	802.11n HT40 CH62 5310 MHz - R	
1+2	Horizontal	Fundamental
<p><b>Peak</b></p>	 <p>Site : 03CH11-HY Condition : PEAK_BE_74 3m HORN 91200-HF HORIZONTAL</p>	<p>Left blank</p>
<p><b>Avg.</b></p>	 <p>Site : 03CH11-HY Condition : AVG_BE_54 3m HORN 91200-HF HORIZONTAL</p>	<p>Left blank</p>

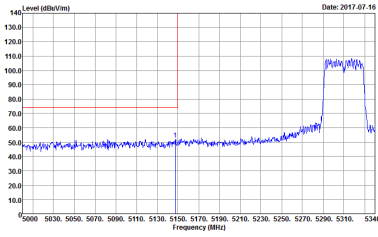
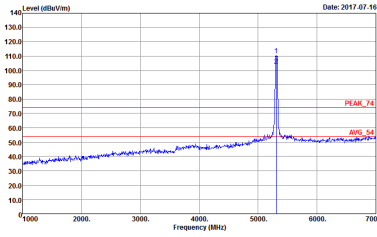
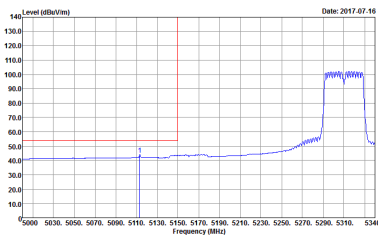

WIFI	Band 2 5250~5350MHz Band Edge @ 3m	
ANT	802.11n HT40 CH62 5310 MHz - L	
1+2	Vertical	Fundamental
Peak	 <p>Site : 03CH11-HY Condition : PEAK BE 74 3m HORN 9120D-HF VERTICAL</p>	 <p>Site : 03CH11-HY Condition : PEAK 74 3m HORN 9120D-HF VERTICAL</p>
Avg.	 <p>Site : 03CH11-HY Condition : AVG BE 54 3m HORN 9120D-HF VERTICAL</p>	Left blank



WIFI	Band 2 5250~5350MHz Band Edge @ 3m	
ANT	802.11n HT40 CH62 5310 MHz - R	
1+2	Vertical	Fundamental
Peak		Left blank
Avg.		Left blank

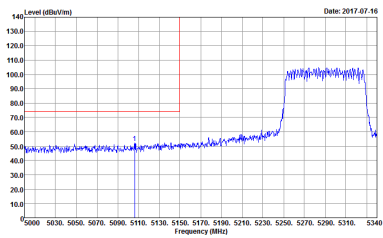
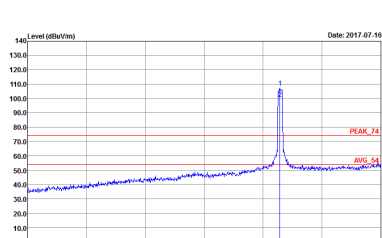
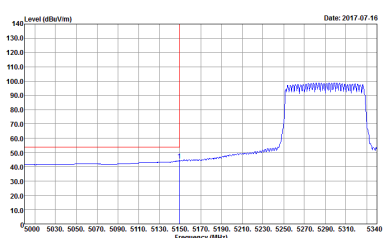

**Band 2 5250~5350MHz**  
**WIFI 802.11ac VHT80 (Band Edge @ 3m)**

WIFI	Band 2 5250~5350MHz Band Edge @ 3m	
ANT	802.11ac VHT80 CH58 5290MHz - L	
1+2	Horizontal	Fundamental
<p align="center"><b>Peak</b></p>	 <p>Site : 03CH11-HY            Condition : PEAK BE 74 3m HORN 9120D-HF HORIZONTAL</p>	 <p>Site : 03CH11-HY            Condition : PEAK 74 3m HORN 9120D-HF HORIZONTAL</p>
<p align="center"><b>Avg.</b></p>	 <p>Site : 03CH11-HY            Condition : AVG BE 54 3m HORN 9120D-HF HORIZONTAL</p>	<p align="center"><b>Left blank</b></p>





WIFI	Band 2 5250~5350MHz Band Edge @ 3m	
ANT	802.11ac VHT80 CH58 5290MHz - R	
1+2	Horizontal	Fundamental
Peak	<p>Site : 03CH11-4HY Condition : PEAK BE 74 3m HORN 91200-HF HORIZONTAL</p>	Left blank
Avg.	<p>Site : 03CH11-4HY Condition : AVG BE 54 3m HORN 91200-HF HORIZONTAL</p>	Left blank

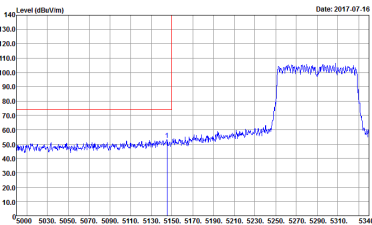
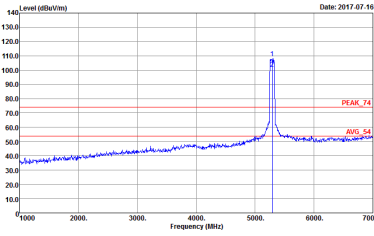
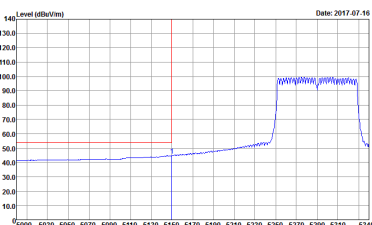

WIFI	Band 2 5250~5350MHz Band Edge @ 3m	
ANT	802.11ac VHT80 CH58 5290MHz - L	
1+2	Vertical	Fundamental
Peak	 <p>Site : 03CH11-HY Condition : PEAK BE 74 3m HORN 9120D-HF VERTICAL</p>	 <p>Site : 03CH11-HY Condition : PEAK 74 3m HORN 9120D-HF VERTICAL</p>
Avg.	 <p>Site : 03CH11-HY Condition : AVG BE 54 3m HORN 9120D-HF VERTICAL</p>	Left blank

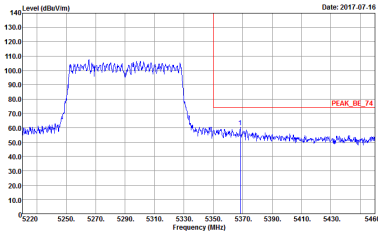
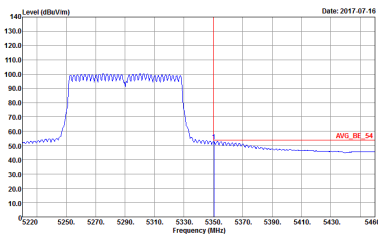

WIFI	Band 2 5250~5350MHz Band Edge @ 3m	
ANT	802.11ac VHT80 CH58 5290MHz - R	
1+2	Vertical	Fundamental
Peak	 <p>Site : 03CH11-HY Condition : PEAK BE 74 3m HORN 91200-HF VERTICAL</p>	Left blank
Avg.	 <p>Site : 03CH11-HY Condition : AVG BE 54 3m HORN 91200-HF VERTICAL</p>	Left blank



**Band 2 - 5250~5350MHz**  
**WIFI 802.11a (Harmonic @ 3m)**

<b>WIFI</b>	<b>Band 2 5250~5350MHz Harmonic @ 3m</b>	
<b>ANT</b>	<b>802.11a CH52 5260MHz</b>	
<b>1+2</b>	<b>Horizontal</b>	<b>Vertical</b>
<b>Peak Avg.</b>	<p>Site : 03CHI1-HY          Condition : PEA(KUNII) 3m 9170 SHF HORM 150809 HORIZONTAL</p>	<p>Site : 03CHI1-HY          Condition : PEA(KUNII) 3m 9170 SHF HORM 150809 VERTICAL</p>

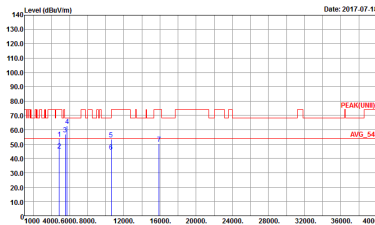
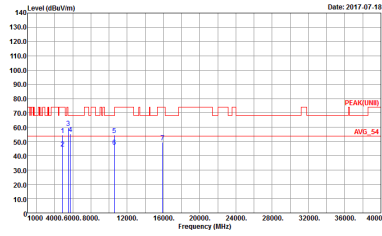

WIFI	Band 2 5250~5350MHz Harmonic @ 3m	
ANT	802.11a CH60 5300MHz	
1+2	Horizontal	Vertical
Peak Avg.	 <p>Date: 2017.07.18</p> <p>Site : 03CH11-HY Condition : PEAK(UNEI) 3m 9170 5HF HORM 150809 HORIZONTAL</p>	 <p>Date: 2017.07.18</p> <p>Site : 03CH11-HY Condition : PEAK(UNEI) 3m 9170 5HF HORM 150809 VERTICAL</p>

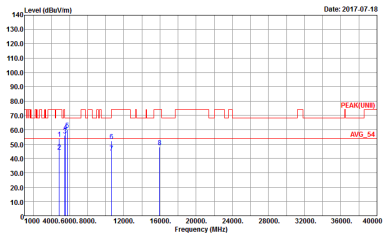
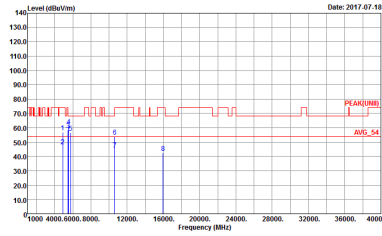

WIFI	Band 2 5250~5350MHz Harmonic @ 3m	
ANT	802.11a CH64 5320MHz	
1+2	Horizontal	Vertical
Peak Avg.	 <p>Site : 03CH11-HY Condition : PEAK(UNEI) 3m 9170 5HF HORM 150809 HORIZONTAL</p>	 <p>Site : 03CH11-HY Condition : PEAK(UNEI) 3m 9170 5HF HORM 150809 VERTICAL</p>



**Band 2 5250~5350MHz**  
**WIFI 802.11n HT20 (Harmonic @ 3m)**

<b>WIFI</b>	<b>Band 2 5250~5350MHz Harmonic @ 3m</b>	
<b>ANT</b>	<b>802.11n HT20 CH52 5260MHz</b>	
<b>1+2</b>	<b>Horizontal</b>	<b>Vertical</b>
<b>Peak</b> <b>Avg.</b>	<p>Site : 03CH11-HY          Condition : PEAK(LINE1) 3m 9170 SHF HORM 150809 HORIZONTAL</p>	<p>Site : 03CH11-HY          Condition : PEAK(LINE1) 3m 9170 SHF HORM 150809 VERTICAL</p>



WIFI	Band 2 5250~5350MHz Harmonic @ 3m	
ANT	802.11n HT20 CH60 5300MHz	
1+2	Horizontal	Vertical
Peak Avg.	<p>Site : 03CH11-HY Condition : PEAK 74 3m 9170 SHF HORM 150809 HORIZONTAL</p>	<p>Site : 03CH11-HY Condition : PEAK 74 3m 9170 SHF HORM 150809 VERTICAL</p>





WIFI	Band 2 5250~5350MHz Harmonic @ 3m	
ANT	802.11n HT20 CH64 5320MHz	
1+2	Horizontal	Vertical
Peak Avg.	<p>Site : 03CH11-HY Condition : PEAK 74 3m 9170 SHF HORM 150809 HORIZONTAL</p>	<p>Site : 03CH11-HY Condition : PEAK 74 3m 9170 SHF HORM 150809 VERTICAL</p>



Band 2 5250~5350MHz
WIFI 802.11n HT40 (Harmonic @ 3m)

Table with 3 columns: WIFI, ANT, 1+2. It contains two graphs: Horizontal and Vertical. Each graph shows Level (dBuV/m) vs Frequency (MHz) with peak and average values indicated.



WIFI	Band 2 5250~5350MHz Harmonic @ 3m	
ANT	802.11n HT40 CH62 5310 MHz	
1+2	Horizontal	Vertical
Peak Avg.	<p>Site : 03CH11-HY Condition : PEAK 74 3m 9170 SHF HORM 150809 HORIZONTAL</p>	<p>Site : 03CH11-HY Condition : PEAK 74 3m 9170 SHF HORM 150809 VERTICAL</p>



**Band 2 5250~5350MHz  
WIFI 802.11ac VHT80 (Harmonic @ 3m)**

<b>WIFI</b>	<b>Band 2 5250~5350MHz Harmonic @ 3m</b>	
<b>ANT</b>	<b>802.11ac VHT80 CH58 5290MHz</b>	
<b>1+2</b>	<b>Horizontal</b>	<b>Vertical</b>
<b>Peak Avg.</b>	<p>Site : 03CH11-HY Condition : PEAK 74 3m 9170 5HF HORM 150809 HORIZONTAL</p>	<p>Site : 03CH11-HY Condition : PEAK 74 3m 9170 5HF HORM 150809 VERTICAL</p>



**Band 3 - 5470~5725MHz**  
**WIFI 802.11a (Band Edge @ 3m)**

WIFI	Band 3 5470~5725MHz Band Edge @ 3m	
ANT	802.11a CH100 5500MHz	
1+2	Horizontal	Fundamental
<b>Peak</b>	<p>Site : 03CH11-HY            Condition : PEAK BE(LNIII) B3 3m HORN 9120D-HF HORIZONTAL</p>	<p>Site : 03CH11-HY            Condition : PEAK(LNIII) 3m HORN 9120D-HF HORIZONTAL</p>
<b>Avg.</b>	<p>Site : 03CH11-HY            Condition : AVG BE(LNIII) B3 3m HORN 9120D-HF HORIZONTAL</p>	<b>Left blank</b>



WIFI	Band 3 5470~5725MHz Band Edge @ 3m	
ANT	802.11a CH100 5500MHz	
1+2	Vertical	Fundamental
Peak	<p>Site : 03CH11-HY Condition : PEAK BE(LUNII) B3 3m HORN 9120D-HF VERTICAL</p>	<p>Site : 03CH11-HY Condition : PEAK(LUNII) 3m HORN 9120D-HF VERTICAL</p>
Avg.	<p>Site : 03CH11-HY Condition : AVG BE(LUNII) B3 3m HORN 9120D-HF VERTICAL</p>	Left blank

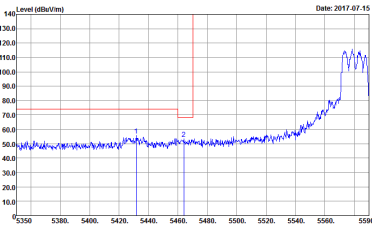
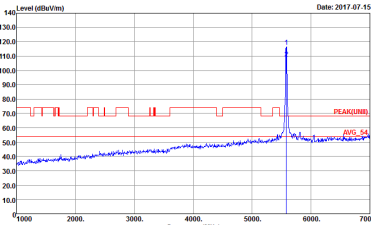
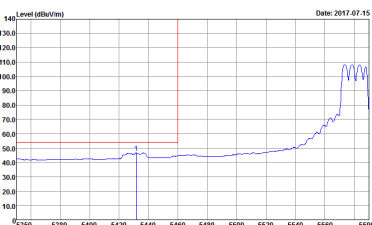

WIFI	Band 3 5470~5725MHz Band Edge @ 3m	
ANT	802.11a CH116 5580MHz - L	
1+2	Horizontal	Fundamental
<p><b>Peak</b></p>	 <p>Site : 03CH11-HY Condition : PEAK BE(LUNII) B3 3m HORN 9120D-HF HORIZONTAL</p>	 <p>Site : 03CH11-HY Condition : PEAK(LUNII) 3m HORN 9120D-HF HORIZONTAL</p>
<p><b>Avg.</b></p>	 <p>Site : 03CH11-HY Condition : AVG BE(LUNII) B3 3m HORN 9120D-HF HORIZONTAL</p>	<p>Left blank</p>

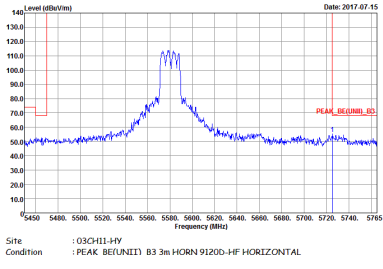

WIFI	Band 3 5470~5725MHz Band Edge @ 3m	
ANT	802.11a CH116 5580MHz - R	
1+2	Horizontal	Fundamental
Peak		Left blank





WIFI	Band 3 5470~5725MHz Band Edge @ 3m	
ANT	802.11a CH116 5580MHz - L	
1+2	Vertical	Fundamental
Peak	<p>Site : 03CH11-HY Condition : PEAK BE(LNII) B3 3m HORN 9120D-HF VERTICAL</p>	<p>Site : 03CH11-HY Condition : PEAK(LNII) 3m HORN 9120D-HF VERTICAL</p>
Avg.	<p>Site : 03CH11-HY Condition : AVG BE(LNII) B3 3m HORN 9120D-HF VERTICAL</p>	Left blank

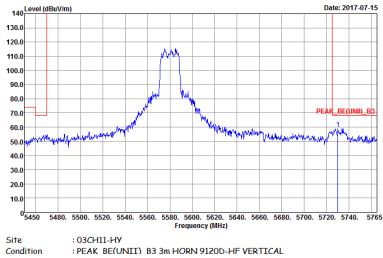

<b>WIFI</b>	<b>Band 3 5470~5725MHz Band Edge @ 3m</b>	
<b>ANT</b>	<b>802.11a CH116 5580MHz - R</b>	
<b>1+2</b>	<b>Vertical</b>	<b>Fundamental</b>
<b>Peak</b>	 <p>Site : 03CH11-HY Condition : PEAK_BETUNIII B3 3m HORN 91200-HF VERTICAL</p>	<b>Left blank</b>

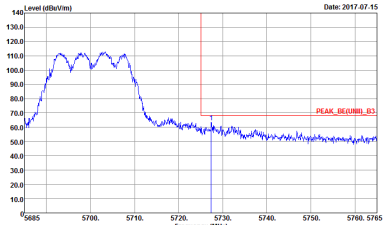
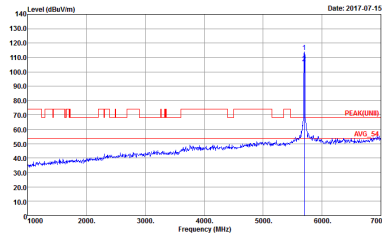

WIFI	Band 3 5470~5725MHz Band Edge @ 3m	
ANT	802.11a CH140 5700MHz	
1+2	Horizontal	Fundamental
Peak	 <p>Site : 03CH11-HY Condition : PEAK_BE(UINII) B3 3m HORN 9120D-HF HORIZONTAL</p>	 <p>Site : 03CH11-HY Condition : PEAK(UINII) 3m HORN 9120D-HF HORIZONTAL</p>

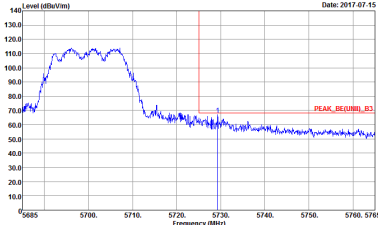
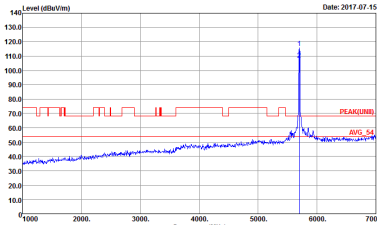

WIFI	Band 3 5470~5725MHz Band Edge @ 3m	
ANT	802.11a CH140 5700MHz	
1+2	Vertical	Fundamental
Peak	 <p>Date: 2017.07.15</p> <p>Site : 03CH11-HY Condition : PEAK_BEQ(III) B3 3m HORN 9120D-HF VERTICAL</p>	 <p>Date: 2017.07.15</p> <p>Site : 03CH11-HY Condition : PEAK(III) 3m HORN 9120D-HF VERTICAL</p>



Band 3 5470~5725MHz
WIFI 802.11n HT20 (Band Edge @ 3m)

Table with 2 columns (Horizontal, Fundamental) and 2 rows (Peak, Avg.). Contains spectral plots and labels like 'Peak', 'Fundamental', 'Avg.', and 'Left blank'.



WIFI	Band 3 5470~5725MHz Band Edge @ 3m	
ANT	802.11n HT20 CH100 5500MHz	
1+2	Vertical	Fundamental
Peak	<p>Site : 03CH11-HY Condition : PEAK BE(LNII) B3 3m HORN 9120D-HF VERTICAL</p>	<p>Site : 03CH11-HY Condition : PEAK(LNII) 3m HORN 9120D-HF VERTICAL</p>
Avg.	<p>Site : 03CH11-HY Condition : AVG BE(LNII) B3 3m HORN 9120D-HF VERTICAL</p>	Left blank

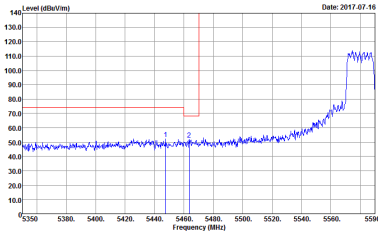
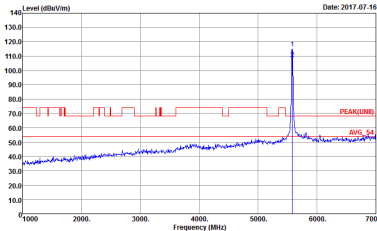
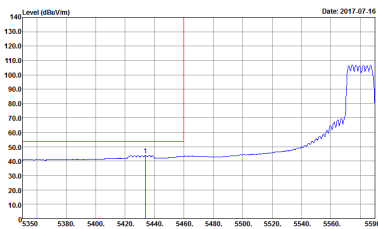

WIFI	Band 3 5470~5725MHz Band Edge @ 3m	
ANT	802.11n HT20 CH116 5580MHz - L	
1+2	Horizontal	Fundamental
<p><b>Peak</b></p>	 <p>Site : 03CH11-HY Condition : PEAK BE(LINE1) B3 3m HORN 9120D-HF HORIZONTAL</p>	 <p>Site : 03CH11-HY Condition : PEAK(LINE1) 3m HORN 9120D-HF HORIZONTAL</p>
<p><b>Avg.</b></p>	 <p>Site : 03CH11-HY Condition : AVG BE(LINE1) B3 3m HORN 9120D-HF HORIZONTAL</p>	<p>Left blank</p>

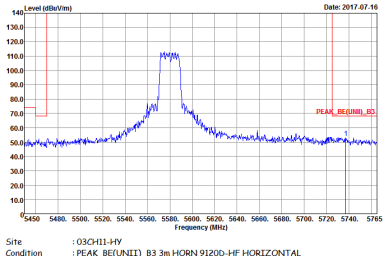

WIFI	Band 3 5470~5725MHz Band Edge @ 3m	
ANT	802.11n HT20 CH116 5580MHz - R	
1+2	Horizontal	Fundamental
Peak		Left blank



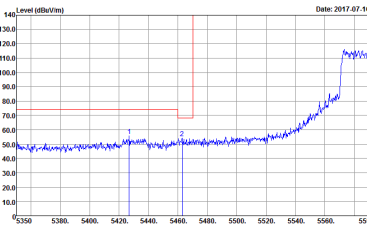
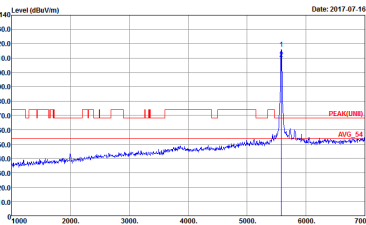
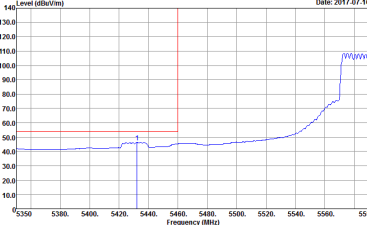

WIFI	Band 3 5470~5725MHz Band Edge @ 3m	
ANT	802.11n HT20 CH116 5580MHz - L	
1+2	Vertical	Fundamental
Peak	 <p>Site : 03CH11-HY Condition : PEAK BE(LNII) B3 3m HORN 9120D-HF VERTICAL</p>	 <p>Site : 03CH11-HY Condition : PEAK(LNII) 3m HORN 9120D-HF VERTICAL</p>
Avg.	 <p>Site : 03CH11-HY Condition : AVG BE(LNII) B3 3m HORN 9120D-HF VERTICAL</p>	Left blank

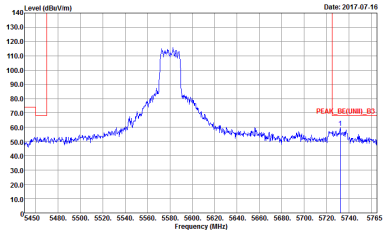

WIFI	Band 3 5470~5725MHz Band Edge @ 3m	
ANT	802.11n HT20 CH116 5580MHz - R	
1+2	Vertical	Fundamental
Peak	 <p>Site : 03CH11-HY Condition : PEAK_BETUNITE1 B3 3m HORN 9120D-HF VERTICAL</p>	Left blank



WIFI	Band 3 5470~5725MHz Band Edge @ 3m	
ANT	802.11n HT20 CH140 5700MHz	
1+2	Horizontal	Fundamental
Peak	<p>Site : 03CH11-HY Condition : PEAK_BE(LINII) B3 3m HORN 9120D-HF HORIZONTAL</p>	<p>Site : 03CH11-HY Condition : PEAK(LINII) 3m HORN 9120D-HF HORIZONTAL</p>



WIFI	Band 3 5470~5725MHz Band Edge @ 3m	
ANT	802.11n HT20 CH140 5700MHz	
1+2	Vertical	Fundamental
Peak.	<p>Site : 03CH11-HY Condition : PEAK_BE(LUNII) B3 3m HORN 9120D-HF VERTICAL</p>	<p>Site : 03CH11-HY Condition : PEAK(LUNII) 3m HORN 9120D-HF VERTICAL</p>



**Band 3 5470~5725MHz**  
**WIFI 802.11n HT40 (Band Edge @ 3m)**

WIFI	Band 3 5470~5725MHz Band Edge @ 3m	
ANT	802.11n HT40 CH102 5510MHz - L	
1+2	Horizontal	Fundamental
<b>Peak</b>	<p>Site : 03CH11-HY            Condition : PEAK BE(LUNII) B3 3m HORN 9120D-HF HORIZONTAL</p>	<p>Site : 03CH11-HY            Condition : PEAK(LUNII) 3m HORN 9120D-HF HORIZONTAL</p>
<b>Avg.</b>	<p>Site : 03CH11-HY            Condition : AV6 BE(LUNII) B3 3m HORN 9120D-HF HORIZONTAL</p>	<b>Left blank</b>

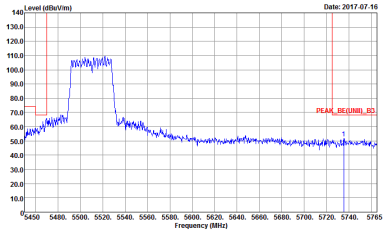

WIFI	Band 3 5470~5725MHz Band Edge @ 3m	
ANT	802.11n HT40 CH102 5510MHz - R	
1+2	Horizontal	Fundamental
Peak	 <p>Site : 03CH11-HY Condition : PEAK_BETUNIII B3 3m HORN 91200-HF HORIZONTAL</p>	Left blank

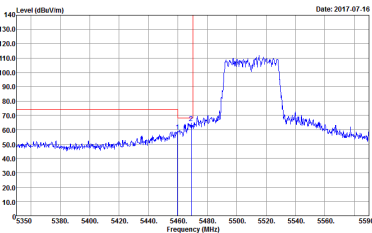
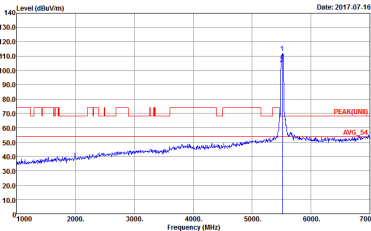
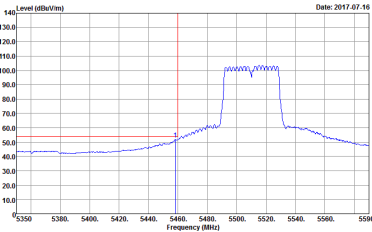

WIFI	Band 3 5470~5725MHz Band Edge @ 3m	
ANT	802.11n HT40 CH102 5510MHz - L	
1+2	Vertical	Fundamental
Peak	 <p>Site : 03CH11-HY Condition : PEAK BE(LUNII) B3 3m HORN 9120D-HF VERTICAL</p>	 <p>Site : 03CH11-HY Condition : PEAK(LUNII) 3m HORN 9120D-HF VERTICAL</p>
Avg.	 <p>Site : 03CH11-HY Condition : AVG BE(LUNII) B3 3m HORN 9120D-HF VERTICAL</p>	Left blank

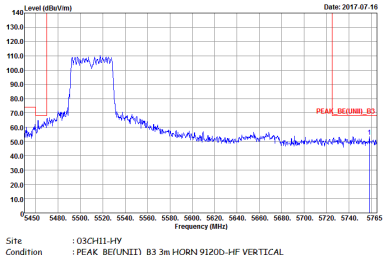

WIFI	Band 3 5470~5725MHz Band Edge @ 3m	
ANT	802.11n HT40 CH102 5510MHz - R	
1+2	Vertical	Fundamental
Peak		Left blank





WIFI	Band 3 5470~5725MHz Band Edge @ 3m	
ANT	802.11n HT40 CH110 5550MHz - L	
1+2	Horizontal	Fundamental
<p><b>Peak</b></p>	<p>Site : 03CH11-HY Condition : PEAK BE(UNII) B3 3m HORN 9120D-HF HORIZONTAL</p>	<p>Site : 03CH11-HY Condition : PEAK(UNII) 3m HORN 9120D-HF HORIZONTAL</p>
<p><b>Avg.</b></p>	<p>Site : 03CH11-HY Condition : AVG BE(UNII) B3 3m HORN 9120D-HF HORIZONTAL</p>	<p>Left blank</p>

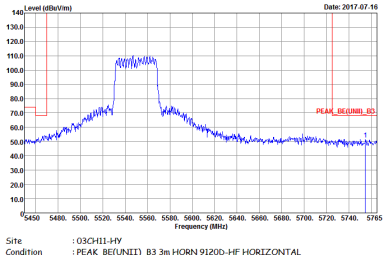

<b>WIFI</b>	<b>Band 3 5470~5725MHz Band Edge @ 3m</b>	
<b>ANT</b>	<b>802.11n HT40 CH110 5550MHz - R</b>	
<b>1+2</b>	<b>Horizontal</b>	<b>Fundamental</b>
<b>Peak</b>		<b>Left blank</b>

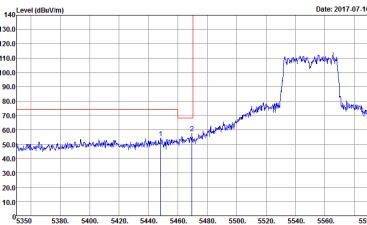
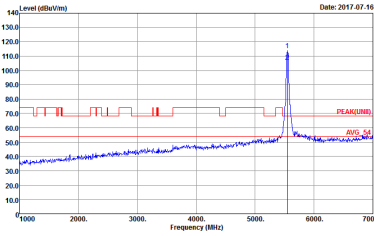
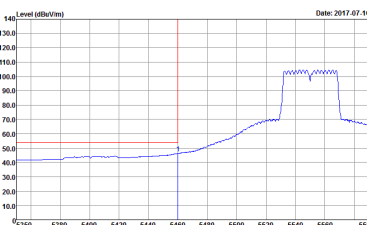

WIFI	Band 3 5470~5725MHz Band Edge @ 3m	
ANT	802.11n HT40 CH110 5550MHz - L	
1+2	Vertical	Fundamental
<p><b>Peak</b></p>	 <p>Site : 03CH11-HY Condition : PEAK BE(LUNII) B3 3m HORN 9120D-HF VERTICAL</p>	 <p>Site : 03CH11-HY Condition : PEAK(LUNII) 3m HORN 9120D-HF VERTICAL</p>
<p><b>Avg.</b></p>	 <p>Site : 03CH11-HY Condition : AVG BE(LUNII) B3 3m HORN 9120D-HF VERTICAL</p>	<p>Left blank</p>

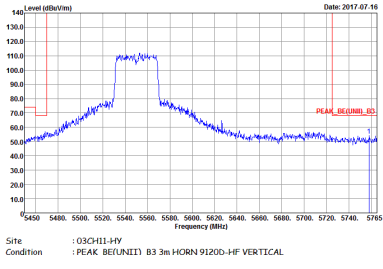

WIFI	Band 3 5470~5725MHz Band Edge @ 3m	
ANT	802.11n HT40 CH110 5550MHz - R	
1+2	Vertical	Fundamental
Peak		Left blank

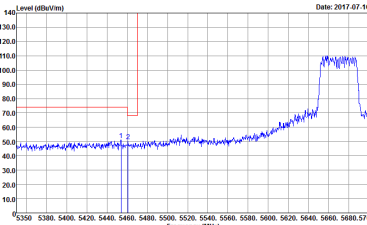
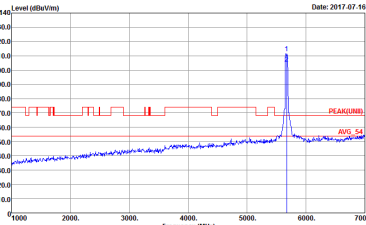
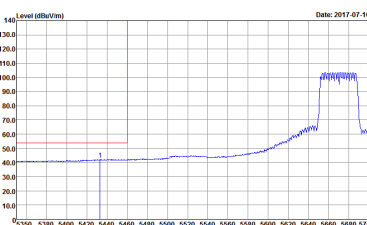

WIFI	Band 3 5470~5725MHz Band Edge @ 3m	
ANT	802.11n HT40 CH134 5670MHz - L	
1+2	Horizontal	Fundamental
Peak	 <p>Site : 03CH11-HY Condition : PEAK BE(FUNII) B3 3m HORN 9120D-HF HORIZONTAL</p>	 <p>Site : 03CH11-HY Condition : PEAK(FUNII) 3m HORN 9120D-HF HORIZONTAL</p>
Avg.	 <p>Site : 03CH11-HY Condition : AVG BE(FUNII) B3 3m HORN 9120D-HF HORIZONTAL</p>	Left blank



<b>WIFI</b>	<b>Band 3 5470~5725MHz Band Edge @ 3m</b>	
<b>ANT</b>	<b>802.11n HT40 CH134 5670MHz - R</b>	
<b>1+2</b>	<b>Horizontal</b>	<b>Fundamental</b>
<b>Peak</b>	<p>Site : 03CHI1-HY Condition : PEAK_BEGIN(B3) B3 3m HORN 9120D-HF HORIZONTAL</p>	<b>Left blank</b>

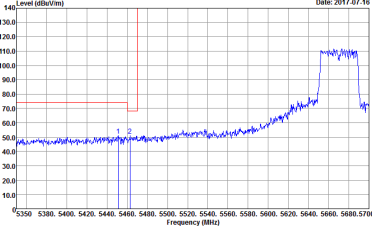
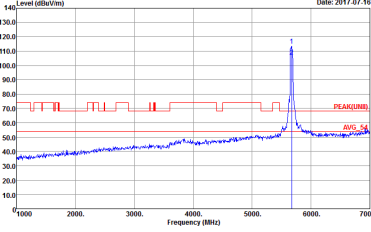
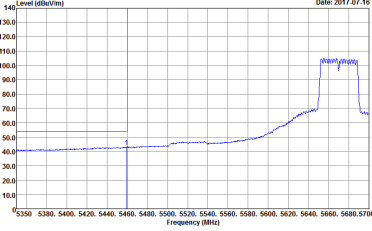

WIFI	Band 3 5470~5725MHz Band Edge @ 3m	
ANT	802.11n HT40 CH134 5670MHz - L	
1+2	Vertical	Fundamental
Peak	 <p>Site : 03CH11-HY Condition : PEAK BE(LINE1) B3 3m HORN 9120D-HF VERTICAL</p>	 <p>Site : 03CH11-HY Condition : PEAK(LINE1) 3m HORN 9120D-HF VERTICAL</p>
Avg.	 <p>Site : 03CH11-HY Condition : AVG BE(LINE1) B3 3m HORN 9120D-HF VERTICAL</p>	Left blank



WIFI	Band 3 5470~5725MHz Band Edge @ 3m	
ANT	802.11n HT40 CH134 5670MHz - R	
1+2	Vertical	Fundamental
Peak	<p>Site : 03CH11-HY Condition : PEAK_BETUNE11 B3 3m HORN 9120D-HF VERTICAL</p>	Left blank





**Band 3 5470~5725MHz  
WIFI 802.11ac VHT80 (Band Edge @ 3m)**

WIFI	Band 3 5470~5725MHz Band Edge @ 3m	
ANT	802.11ac VHT80 CH106 5530MHz - L	
1+2	Horizontal	Fundamental
<b>Peak</b>	<p>Site : 03CH11-HY Condition : PEAK BE(LINE1) B3 3m HORN 9120D-HF HORIZONTAL</p>	<p>Site : 03CH11-HY Condition : PEAK(LINE1) 3m HORN 9120D-HF HORIZONTAL</p>
<b>Avg.</b>	<p>Site : 03CH11-HY Condition : AVG BE(LINE1) B3 3m HORN 9120D-HF HORIZONTAL</p>	<b>Left blank</b>

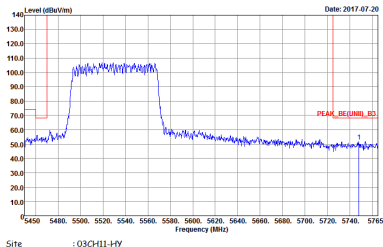

WIFI	Band 3 5470~5725MHz Band Edge @ 3m	
ANT	802.11ac VHT80 CH106 5530MHz - R	
1+2	Horizontal	Fundamental
Peak	 <p>Site : 03CH11-4-F Condition : PEAK_BE(UNIT) B3 3m HORN 91200-HF HORIZONTAL</p>	Left blank

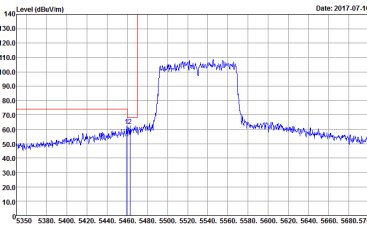
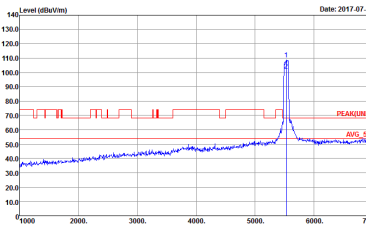
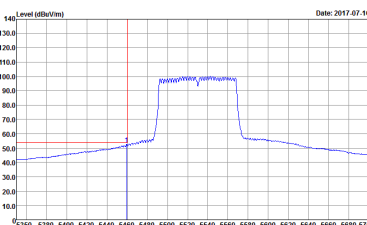

WIFI	Band 3 5470~5725MHz Band Edge @ 3m	
ANT	802.11ac VHT80 CH106 5530MHz - L	
1+2	Vertical	Fundamental
<p><b>Peak</b></p>	 <p>Site : 03CH11-HY Condition : PEAK BE(LNII) B3 3m HORN 9120D-HF VERTICAL</p>	 <p>Site : 03CH11-HY Condition : PEAK(LNII) 3m HORN 9120D-HF VERTICAL</p>
<p><b>Avg.</b></p>	 <p>Site : 03CH11-HY Condition : AVG BE(LNII) B3 3m HORN 9120D-HF VERTICAL</p>	<p><b>Left blank</b></p>

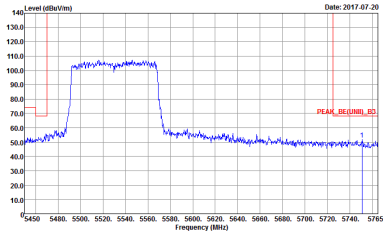

WIFI	Band 3 5470~5725MHz Band Edge @ 3m	
ANT	802.11ac VHT80 CH106 5530MHz - R	
1+2	Vertical	Fundamental
Peak	 <p>Site : 03CHI-HY Condition : PEAK_BE(LINII) B3 3m HORN 91200-HF VERTICAL</p>	Left blank

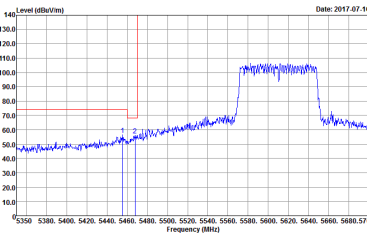
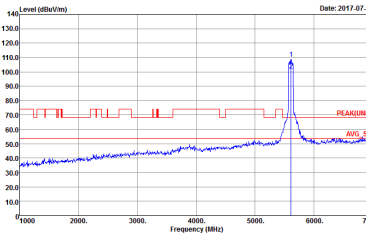
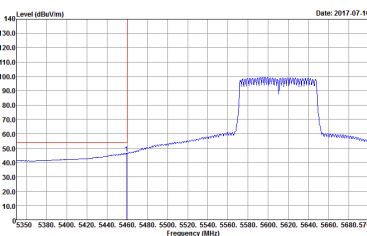

WIFI	Band 3 5470~5725MHz Band Edge @ 3m	
ANT	802.11ac VHT80 CH122 5610MHz - L	
1+2	Horizontal	Fundamental
<p><b>Peak</b></p>	 <p>Site : 03CH11-HY Condition : PEAK BE(LINE1) B3 3m HORN 9120D-HF HORIZONTAL</p>	 <p>Site : 03CH11-HY Condition : PEAK(LINE1) 3m HORN 9120D-HF HORIZONTAL</p>
<p><b>Avg.</b></p>	 <p>Site : 03CH11-HY Condition : AVG BE(LINE1) B3 3m HORN 9120D-HF HORIZONTAL</p>	<p><b>Left blank</b></p>



<b>WIFI</b>	<b>Band 3 5470~5725MHz Band Edge @ 3m</b>	
<b>ANT</b>	<b>802.11ac VHT80 CH122 5610MHz - R</b>	
<b>1+2</b>	<b>Horizontal</b>	<b>Fundamental</b>
<b>Peak</b>	<p>Site : 03CH114FY Condition : PEAK_BE(LINII) B3 3m HORN 91200-HF HORIZONTAL</p>	<b>Left blank</b>

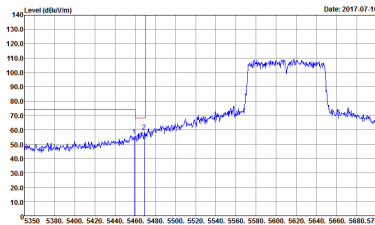
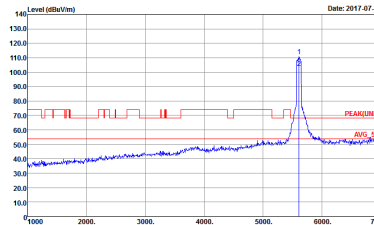
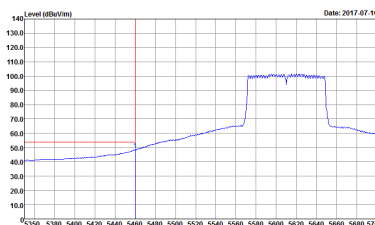

WIFI	Band 3 5470~5725MHz Band Edge @ 3m	
ANT	802.11ac VHT80 CH122 5610MHz - L	
1+2	Vertical	Fundamental
Peak	 <p>Date: 2017.07.16</p> <p>Site : 03CH11-HY Condition : PEAK BE(LINE1) B3 3m HORN 9120D-HF VERTICAL</p>	 <p>Date: 2017.07.16</p> <p>Site : 03CH11-HY Condition : PEAK(LINE1) 3m HORN 9120D-HF VERTICAL</p>
Avg.	 <p>Date: 2017.07.16</p> <p>Site : 03CH11-HY Condition : AVG BE(LINE1) B3 3m HORN 9120D-HF VERTICAL</p>	Left blank

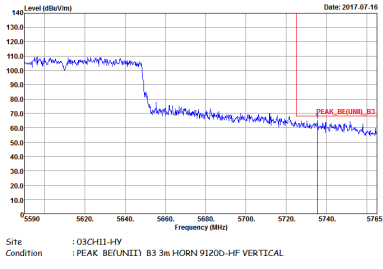

<b>WIFI</b>	<b>Band 3 5470~5725MHz Band Edge @ 3m</b>	
<b>ANT</b>	<b>802.11ac VHT80 CH122 5610MHz - R</b>	
<b>1+2</b>	<b>Vertical</b>	<b>Fundamental</b>
<b>Peak</b>	 <p>Site : 03CHI1-HY Condition : PEAK_BE(LINE1) B3 3m HORN 9120D-HF VERTICAL</p>	<b>Left blank</b>





Band 3 - 5470~5725MHz  
WIFI 802.11a (Harmonic @ 3m)

WIFI	Band 3 5470~5725MHz Harmonic @ 3m	
ANT	802.11a CH100 5500MHz	
1+2	Horizontal	Vertical
Peak Avg.	<p>Site : 03CH11-HY Condition : PEAK(LINE1) 3m 9170 SHF HORM 150809 HORIZONTAL</p>	<p>Site : 03CH11-HY Condition : PEAK(LINE1) 3m 9170 SHF HORM 150809 VERTICAL</p>



WIFI	Band 3 5470~5725MHz Harmonic @ 3m	
ANT	802.11a CH116 5580MHz	
1+2	Horizontal	Vertical
Peak Avg.		



WIFI	Band 3 5470~5725MHz Harmonic @ 3m	
ANT	802.11a CH140 5700MHz	
1+2	Horizontal	Vertical
Peak Avg.	<p>Site : 03CH11-HY Condition : PEAK(UNII) 3m 9170 SHF HORM 150809 HORIZONTAL</p>	<p>Site : 03CH11-HY Condition : PEAK(UNII) 3m 9170 SHF HORM 150809 VERTICAL</p>



Band 3 5470~5725MHz  
WIFI 802.11n HT20 (Harmonic @ 3m)

WIFI	Band 3 5470~5725MHz Harmonic @ 3m	
ANT	802.11n HT20 CH100 5500MHz	
1+2	Horizontal	Vertical
Peak Avg.	<p>Site : 03CH11-HY Condition : PEAK(LINE1) 3m 9170 SHF HORM 150809 HORIZONTAL</p>	<p>Site : 03CH11-HY Condition : PEAK(LINE1) 3m 9170 SHF HORM 150809 VERTICAL</p>



WIFI	Band 3 5470~5725MHz Harmonic @ 3m	
ANT	802.11n HT20 CH116 5580MHz	
1+2	Horizontal	Vertical
Peak Avg.	<p>Site : 03CH11-HY Condition : PEAK(UNII) 3m 9170 SHF HORM 150809 HORIZONTAL</p>	<p>Site : 03CH11-HY Condition : PEAK(UNII) 3m 9170 SHF HORM 150809 VERTICAL</p>



WIFI	Band 3 5470~5725MHz Harmonic @ 3m	
ANT	802.11n HT20 CH140 5700MHz	
1+2	Horizontal	Vertical
Peak Avg.	<p>Site : 03CH11-HY Condition : PEAK(LINE1) 3m 9170 SHF HORM 150809 HORIZONTAL</p>	<p>Site : 03CH11-HY Condition : PEAK(LINE1) 3m 9170 SHF HORM 150809 VERTICAL</p>



Band 3 5470~5725MHz
WIFI 802.11n HT40 (Harmonic @ 3m)

Table with 3 columns: WIFI, ANT, 1+2. It contains two spectral plots: Horizontal and Vertical. The plots show Level (dBm/Vm) vs Frequency (MHz) with peak and average values indicated. Site and condition details are provided below each plot.



WIFI	Band 3 5470~5725MHz Harmonic @ 3m	
ANT	802.11n HT40 CH110 5550MHz	
1+2	Horizontal	Vertical
Peak Avg.	<p>Site : 03CH11-HY Condition : PEAKUNII 3m 9170 SHF HORM 150809 HORIZONTAL</p>	<p>Site : 03CH11-HY Condition : PEAKUNII 3m 9170 SHF HORM 150809 VERTICAL</p>





WIFI	Band 3 5470~5725MHz Harmonic @ 3m	
ANT	802.11n HT40 CH134 5670MHz	
1+2	Horizontal	Vertical
Peak Avg.	<p>Site : 03CH11-HY Condition : PEAK(UNII) 3m 9170 SH-F HORM 150809 HORIZONTAL</p>	<p>Site : 03CH11-HY Condition : PEAK(UNII) 3m 9170 SH-F HORM 150809 VERTICAL</p>



**Band 3 5470~5725MHz**  
**WIFI 802.11ac VHT80 (Harmonic @ 3m)**

WIFI	Band 3 5470~5725MHz Harmonic @ 3m	
ANT	802.11ac VHT80 CH106 5530MHz	
1+2	Horizontal	Vertical
Peak Avg.	<p>Site : 03CH11-HY Condition : PEAK(LINE1) 3m 9170 SHF HORM 150809 HORIZONTAL</p>	<p>Site : 03CH11-HY Condition : PEAK(LINE1) 3m 9170 SHF HORM 150809 VERTICAL</p>



WIFI	Band 3 5470~5725MHz Harmonic @ 3m	
ANT	802.11ac VHT80 CH122 5610MHz	
1+2	Horizontal	Vertical
Peak Avg.	<p>Site : 03CH11-HY Condition : PEAK(LINE1) 3m 9170 SHF HORM 150809 HORIZONTAL</p>	<p>Site : 03CH11-HY Condition : PEAK(LINE1) 3m 9170 SHF HORM 150809 VERTICAL</p>



Band 3 - Straddle Channel
WIFI 802.11a (Fundamental @ 3m)

Table with 2 columns: Horizontal and Vertical. Contains two line graphs showing Level (dBm/m) vs Frequency (MHz) for Peak and Avg. measurements. Includes site and condition details.

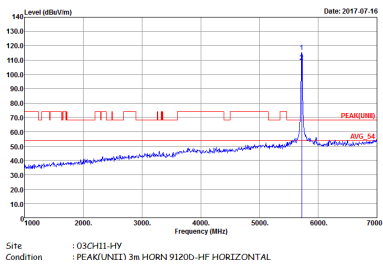
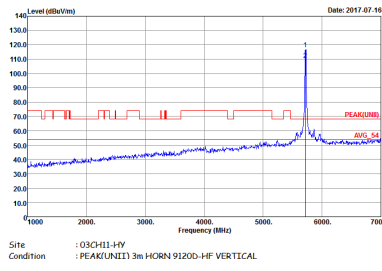

Band 3 – Straddle Channel  
WIFI 802.11n HT20 (Fundamental @ 3m)

WIFI	Band 3 Straddle Channel Fundamental @ 3m	
ANT	802.11n HT20 CH144 5720MHz	
1+2	Horizontal	Vertical
Peak Avg.		



Band 3 – Straddle Channel  
WIFI 802.11n HT40 (Fundamental @ 3m)

WIFI	Band 3 Straddle Channel Fundamental @ 3m	
ANT	802.11n HT40 CH142 5710MHz	
1+2	Horizontal	Vertical
Peak Avg.	<p style="text-align: center;"><b>v</b></p> <p>Site : 03CH11-HY Condition : PEAK(LINE1) 3m HORN 9120D-HF HORIZONTAL</p>	<p>Site : 03CH11-HY Condition : PEAK(LINE1) 3m HORN 9120D-HF VERTICAL</p>



**Band 3 – Straddle Channel  
WIFI 802.11ac VHT80 (Fundamental @ 3m)**

<b>WIFI</b>	<b>Band 3 Straddle Channel Fundamental @ 3m</b>	
<b>ANT</b>	<b>802.11ac VHT80 CH138 5690MHz</b>	
<b>1+2</b>	<b>Horizontal</b>	<b>Vertical</b>
<b>Peak Avg.</b>	<p>Site : 03SCH11-1FY Condition : PEAKUNEE1 3m HORN 9120D-HF HORIZONTAL</p>	<p>Site : 03SCH11-1FY Condition : PEAKUNEE1 3m HORN 9120D-HF VERTICAL</p>



Band 3 - Straddle Channel
WIFI 802.11a (Harmonic @ 3m)

Table with 2 columns: Horizontal and Vertical. Contains two spectral plots showing Level (dBm/1m) vs Frequency (MHz) for Peak and Avg. measurements. Includes site and condition details for each plot.





**Band 3 – Straddle Channel  
WIFI 802.11n HT20 (Harmonic @ 3m)**

<b>WIFI</b>	<b>Band 3 Straddle Channel Harmonic @ 3m</b>	
<b>ANT</b>	<b>802.11n HT20 CH144 5720MHz</b>	
<b>1+2</b>	<b>Horizontal</b>	<b>Vertical</b>
<b>Peak Avg.</b>	<p>Site : 03CH11-HY Condition : PEAKUNEE1 3m 9170 5HF HORM 150809 HORIZONTAL</p>	<p>Site : 03CH11-HY Condition : PEAKUNEE1 3m 9170 5HF HORM 150809 VERTICAL</p>



Band 3 – Straddle Channel  
WIFI 802.11n HT40 (Harmonic @ 3m)

WIFI	Band 3 Straddle Channel Harmonic @ 3m	
ANT	802.11n HT40 CH142 5710MHz	
1+2	Horizontal	Vertical
Peak Avg.	<p>Site : 03CH11-HY Condition : PEAK(UNIT1) 3m 9170 SHF HORM 150809 HORIZONTAL</p>	<p>Site : 03CH11-HY Condition : PEAK(UNIT1) 3m 9170 SHF HORM 150809 VERTICAL</p>



**Band 3 – Straddle Channel  
WIFI 802.11ac VHT80 (Harmonic @ 3m)**

<b>WIFI</b>	<b>Band 3 Straddle Channel Harmonic @ 3m</b>	
<b>ANT</b>	<b>802.11ac VHT80 CH138 5690MHz</b>	
<b>1+2</b>	<b>Horizontal</b>	<b>Vertical</b>
<b>Peak Avg.</b>	<p>Site : 03CH11-HY Condition : PEAK(LINE1) 3m 9170 SHF HORM 150809 HORIZONTAL</p>	<p>Site : 03CH11-HY Condition : PEAK(LINE1) 3m 9170 SHF HORM 150809 VERTICAL</p>



Emission below 1GHz  
5GHz WIFI 802.11a (LF)

WIFI	5GHz WIFI	
ANT	802.11a LF	
1+2	Horizontal	Vertical
QP / Peak	<p>Site : 03CHI1-HY Condition : QP 3m BE-LOG 6111D-LF ETC HORIZONTAL</p>	<p>Site : 03CHI1-HY Condition : QP 3m BE-LOG 6111D-LF ETC VERTICAL</p>



### Appendix E. Duty Cycle Plots

Antenna	Band	Duty Cycle(%)	T(us)	1/T(kHz)	VBW Setting	Duty Factor(dB)
1 + 2	802.11a for Ant. 1	99.05	-	-	10Hz	0.04
1 + 2	802.11a for Ant. 2	98.81	-	-	10Hz	0.05
1 + 2	5GHz 802.11n HT20 for Ant. 1	98.47	-	-	10Hz	0.07
1 + 2	5GHz 802.11n HT20 for Ant. 2	98.97	-	-	10Hz	0.04
1 + 2	5GHz 802.11n HT40 for Ant. 1	98.26	-	-	10Hz	0.08
1 + 2	5GHz 802.11n HT40 for Ant. 2	98.26	-	-	10Hz	0.08
1 + 2	5GHz 802.11ac VHT80 for Ant. 1	98.12	-	-	10Hz	0.08
1 + 2	5GHz 802.11ac VHT80 for Ant. 2	98.12	-	-	10Hz	0.08



MIMO <Ant. 1>

802.11a

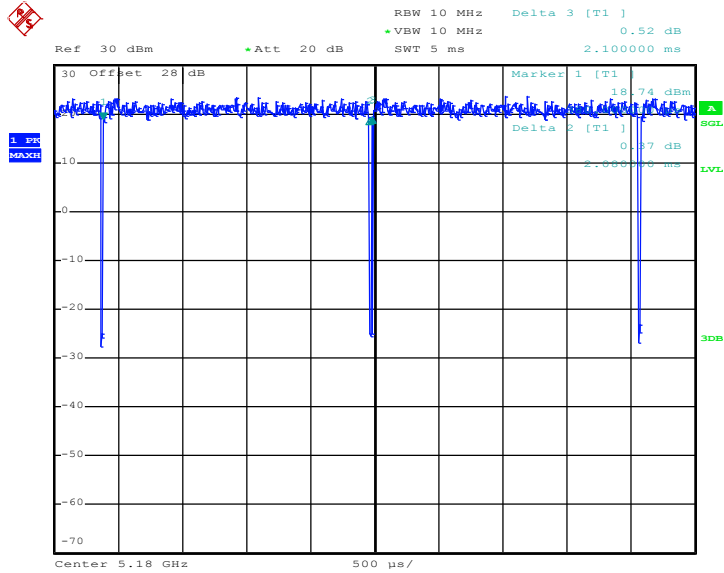

Date: 5.JUL.2017 01:09:23

802.11n HT20

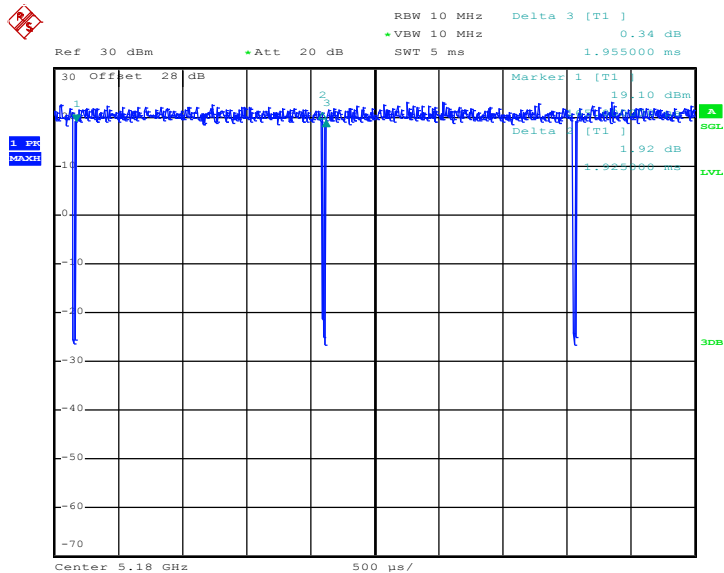

Date: 5.JUL.2017 01:12:47



802.11n HT40

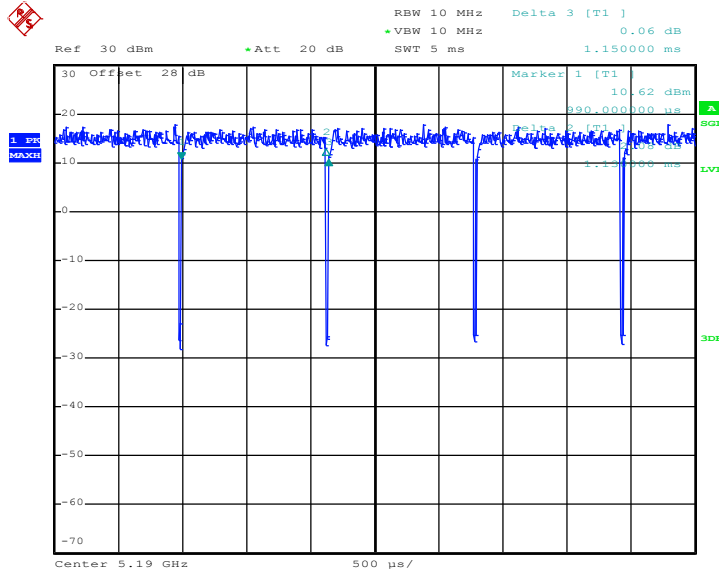

Date: 8.JUL.2017 12:11:34

802.11ac VHT80

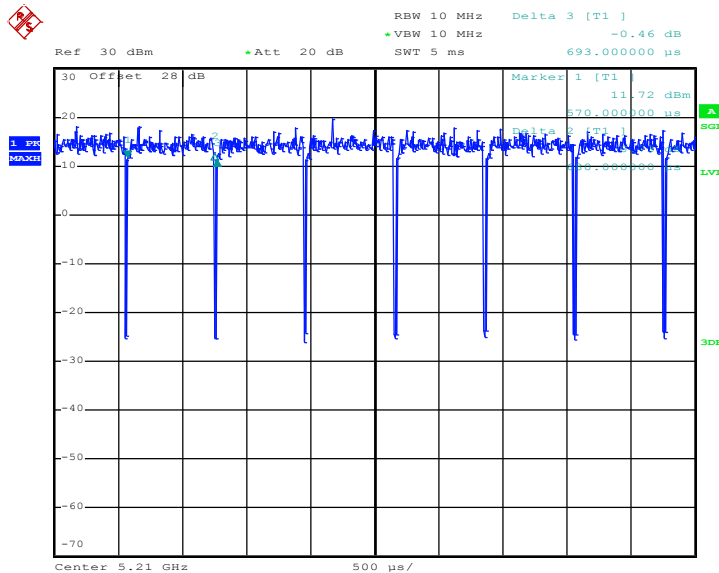

Date: 5.JUL.2017 01:58:15



MIMO <Ant. 2>

802.11a

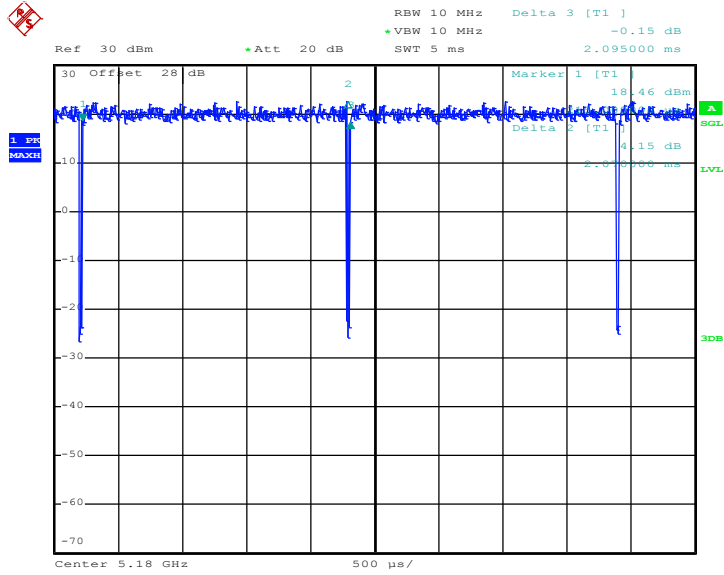

Date: 5.JUL.2017 01:09:52

802.11n HT20

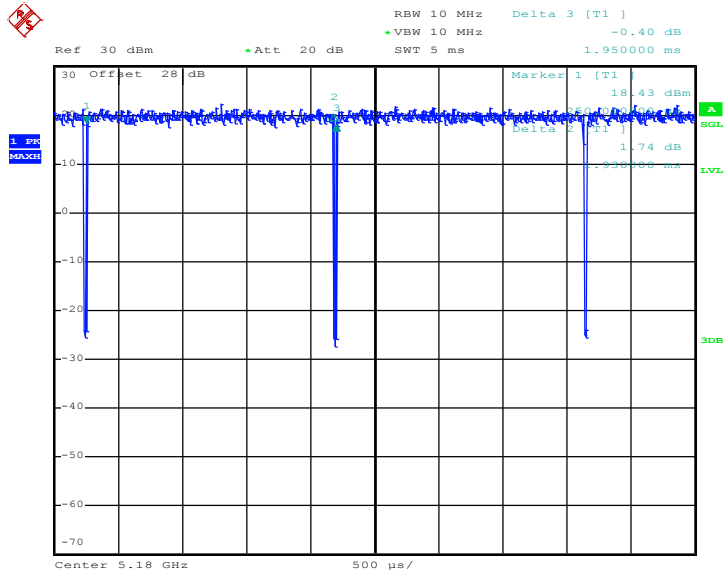

Date: 5.JUL.2017 01:13:16





802.11n HT40

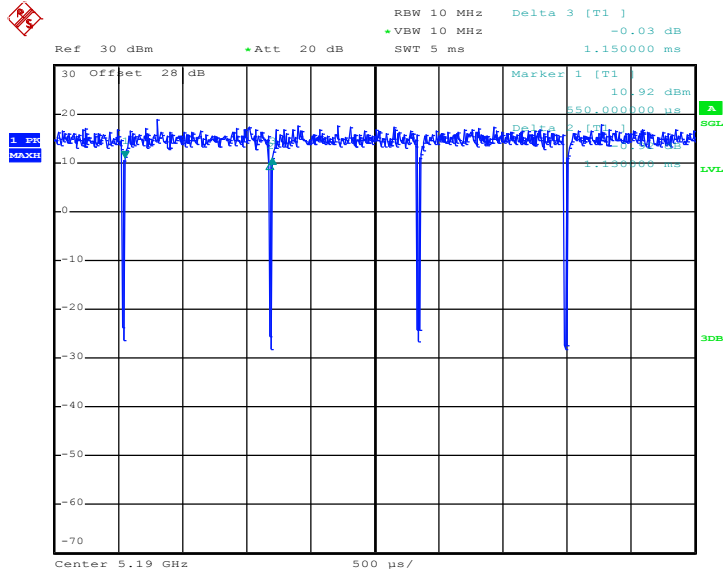

Date: 8.JUL.2017 12:10:50

802.11ac VHT80

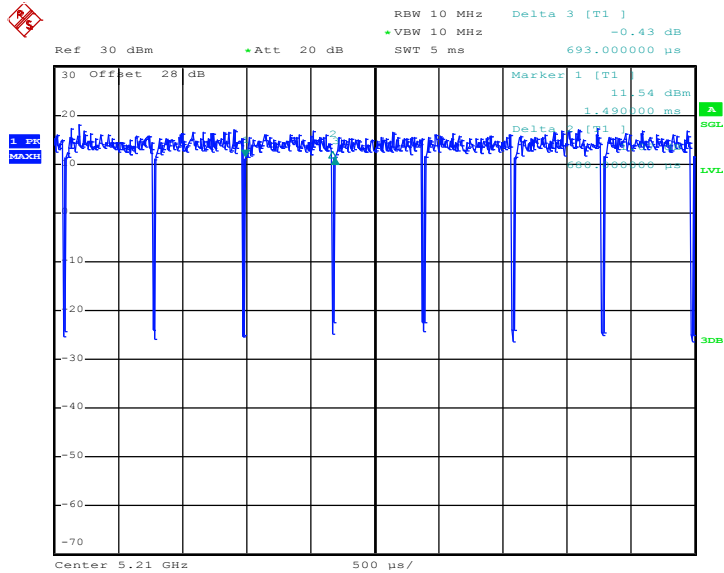

Date: 5.JUL.2017 01:59:11