



FCC RF Co-location Test Report

APPLICANT : Nest Labs Inc.
EQUIPMENT : Outdoor Security Camera
MODEL NAME : Nest Cam IQ
MODEL NUMBER : A0055
FCC ID : ZQANC41
STANDARD : FCC Part 15 Subpart E §15.407
CLASSIFICATION : (NII) Unlicensed National Information Infrastructure

The product was completed on Jul. 27, 2017. We, SPORTON INTERNATIONAL INC., would like to declare that the tested sample has been evaluated in accordance with the test procedures and has been in compliance with the applicable technical standards.

The test results in this report apply exclusively to the tested model / sample. Without written approval of SPORTON INTERNATIONAL INC., the test report shall not be reproduced except in full.

Reviewed by: Joseph Lin / Supervisor

Approved by: Jones Tsai / Manager



Testing Laboratory
1190

SPORTON INTERNATIONAL INC.

No. 52, Hwa Ya 1st Rd., Hwa Ya Technology Park, Kwei-Shan District, Tao Yuan City, Taiwan, R.O.C.



TABLE OF CONTENTS

REVISION HISTORY..... 3

SUMMARY OF TEST RESULT 4

1 GENERAL DESCRIPTION 5

 1.1 Applicant 5

 1.2 Product Feature of Equipment Under Test..... 5

 1.3 Modification of EUT 5

 1.4 Testing Location 6

 1.5 Applicable Standards..... 6

2 TEST CONFIGURATION OF EQUIPMENT UNDER TEST 7

 2.1 Carrier Frequency and Channel 7

 2.2 Test Mode..... 7

 2.3 Connection Diagram of Test System..... 8

 2.4 EUT Operation Test Setup 8

3 TEST RESULT..... 9

 3.1 Unwanted Emissions Measurement 9

 3.2 Antenna Requirements 14

4 LIST OF MEASURING EQUIPMENT 15

5 UNCERTAINTY OF EVALUATION 16

APPENDIX A. RADIATED SPURIOUS EMISSION

APPENDIX B. RADIATED SPURIOUS EMISSION PLOTS

APPENDIX C. DUTY CYCLE PLOTS



REVISION HISTORY

REPORT NO.	VERSION	DESCRIPTION	ISSUED DATE
FR6N0107-01F	Rev. 01	Initial issue of report	Aug. 29, 2017
FR6N0107-01F	Rev. 02	Revising connection diagram of test system in section 2.3.	Sep. 05, 2017



SUMMARY OF TEST RESULT

Report Section	FCC Rule	Description	Limit	Result
3.1	15.407(b)	Unwanted Emissions	$\leq -17, -27$ dBm (depend on band)&15.209(a)	Pass
3.2	15.203 & 15.407(a)	Antenna Requirement	N/A	Pass



1 General Description

1.1 Applicant

Nest Labs Inc.
3400 Hillview Ave. Palo Alto, CA 94304 USA

1.2 Product Feature of Equipment Under Test

Bluetooth-LE, Wi-Fi 2.4GHz 802.11b/g/n/ac, and Wi-Fi 5GHz 802.11a/n/ac, 15.4

Product Specification subjective to this standard	
Antenna Type	WLAN: IFA Antenna Bluetooth: IFA Antenna 15.4: IFA Antenna

1.3 Modification of EUT

No modifications are made to the EUT during all test items.



1.4 Testing Location

Sporton Lab is accredited to ISO 17025 by Taiwan Accreditation Foundation (TAF code : 1190) and the FCC designation No. TW0007 under the FCC 2.948(e) by Mutual Recognition Agreement (MRA) in FCC Test.

Test Site	SPORTON INTERNATIONAL INC.
Test Site Location	No.58, Aly. 75, Ln. 564, Wenhua 3rd Rd. Guishan Dist, Taoyuan City, Taiwan (R.O.C.) TEL: +886-3-327-0868 FAX: +886-3-327-0855
Test Site No.	Sporton Site No.
	03CH11-HY

Note: The test site complies with ANSI C63.4 2014 requirement.

1.5 Applicable Standards

According to the specifications of the manufacturer, the EUT must comply with the requirements of the following standards:

- ♦ FCC Part 15 Subpart E
- ♦ FCC KDB 789033 D02 General UNII Test Procedures New Rules v01r04
- ♦ FCC KDB 662911 D01 Multiple Transmitter Output v02r01.
- ♦ FCC KDB Publication No. 558074 D01 DTS Meas. Guidance v04
- ♦ ANSI C63.10-2013

Remark: All test items were verified and recorded according to the standards and without any deviation during the test.



2 Test Configuration of Equipment Under Test

- a. The EUT has been associated with peripherals and configuration operated in a manner tended to maximize its emission characteristics in a typical application. Frequency range investigated: radiation emission (9 kHz to the 10th harmonic of the highest fundamental frequency or to 40 GHz, whichever is lower). For radiated measurement, pre-scanned in four orthogonal panels, X, Y, Z, Back. The worst cases (Back plane) were recorded in this report.

2.1 Carrier Frequency and Channel

2400-2483.5 MHz 15.4		2400-2483.5 MHz Bluetooth LE	
Channel	Freq. (MHz)	Channel	Freq. (MHz)
18	2440	00	2402

2400-2483.5 MHz 802.11g		5250-5350 MHz Band 2 (U-NII-2A)	
Channel	Freq. (MHz)	Channel	Freq. (MHz)
06	2437	64	5320

2.2 Test Mode

Final test mode of conducted test items and radiated spurious emissions are considering the modulation and worse data rates as below table.

<Co-Location>

Modulation	Data Rate
Bluetooth LE + 15.4	1 Mbps + 250 kbps
802.11g + 15.4	6 Mbps + 250 kbps
802.11a + 15.4	MCS0 + 250 kbps

2.3 Connection Diagram of Test System

<Co-Location Tx Mode>

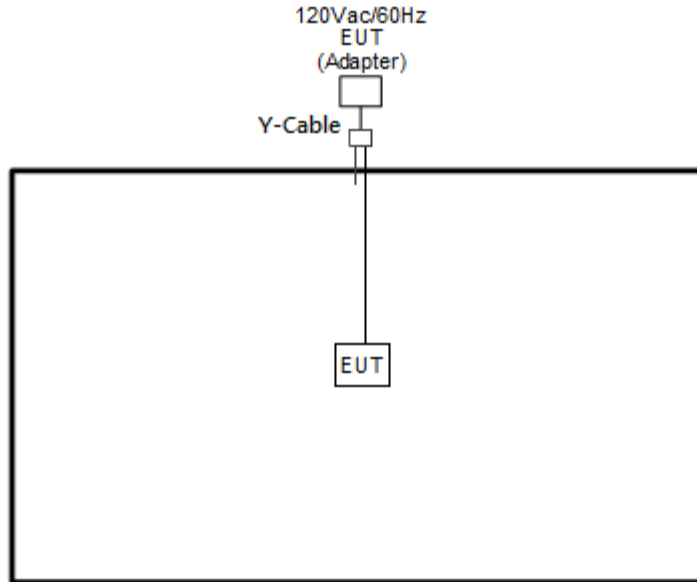

2.4 EUT Operation Test Setup

The RF test items, programmed RF utility, "CMD" installed in the notebook make the EUT provide functions like channel selection and power level for continuous transmitting and receiving signals.



3 Test Result

3.1 Unwanted Emissions Measurement

3.1.1 Limit of Unwanted Emissions

(1) Unwanted spurious emissions fallen in restricted bands shall comply with the general field strength limits as below table,

Frequency (MHz)	Field Strength (microvolts/meter)	Measurement Distance (meters)
0.009 – 0.490	2400/F(kHz)	300
0.490 – 1.705	24000/F(kHz)	30
1.705 – 30.0	30	30
30 – 88	100	3
88 – 216	150	3
216 - 960	200	3
Above 960	500	3

Note: The following formula is used to convert the EIRP to field strength.

$$E = \frac{1000000\sqrt{30P}}{3} \mu\text{V/m, where P is the eirp (Watts)}$$



EIRP (dBm)	Field Strength at 3m (dBµV/m)
- 27	68.3

(2) KDB789033 D02 v01r04 G)2)c)

- (i) Sections 15.407(b)(1) to (b)(3) specify the unwanted emission limits for the U-NII-1 and U-NII-2 bands. As specified, emissions above 1000 MHz that are outside of the restricted bands are subject to a peak emission limit of -27 dBm/MHz.³
- (ii) Section 15.407(b)(4) specifies the unwanted emission limit for the U-NII-3 band. A band emissions mask is specified in Section 15.407(b)(4)(i). The emission limits are in terms of a Peak detector. An alternative to the band emissions mask is specified in Section 15.407(b)(4)(ii). The alternative limits are based on the highest antenna gain specified in the filing. There are also marketing and importation restrictions for the devices using the alternative limit.⁴

Note 3: An out-of-band emission that complies with both the average and peak limits of Section 15.209 is not required to satisfy the -27 dBm/MHz peak emission limit.

Note 4: Only devices with antenna gains of 10 dBi or less may be approved using the emission limits specified in Section 15.247(d) till March 2, 2018; all other devices operating in this band must use the mask specified in Section 15.407(b)(4)(i).

3.1.2 Measuring Instruments

The measuring equipment is listed in the section 4 of this test report.

3.1.3 Test Procedures

1. The testing follows FCC KDB 789033 D02 General UNII Test Procedures New Rules v01r04. Section G) Unwanted emissions measurement.
 - (1) Procedure for Unwanted Emissions Measurements Below 1000MHz
 - RBW = 120 kHz
 - VBW = 300 kHz
 - Detector = Peak
 - Trace mode = max hold



(2) Procedure for Peak Unwanted Emissions Measurements Above 1000 MHz

- RBW = 1 MHz
- VBW \geq 3 MHz
- Detector = Peak
- Sweep time = auto
- Trace mode = max hold

(3) Procedures for Average Unwanted Emissions Measurements Above 1000MHz

- RBW = 1 MHz
- VBW = 10 Hz, when duty cycle is no less than 98 percent.
- VBW \geq 1/T, when duty cycle is less than 98 percent where T is the minimum transmission duration over which the transmitter is on and is transmitting at its maximum power control level for the tested mode of operation.

2. The EUT was placed on a turntable with 0.8 meter for frequency below 1GHz and 1.5 meter for frequency above 1GHz respectively above ground.
3. The EUT was set 3 meters from the interference receiving antenna which was mounted on the top of a variable height antenna tower.
4. The antenna is a broadband antenna and its height is adjusted between one meter and four meters above ground to find the maximum value of the field strength for both horizontal polarization and vertical polarization of the antenna.
5. For each suspected emission, the EUT was arranged to its worst case and then adjust the antenna tower (from 1 m to 4 m) and turntable (from 0 degree to 360 degrees) to find the maximum reading.
6. For testing below 1GHz, if the emission level of the EUT in peak mode was 3 dB lower than the limit specified, then peak values of EUT will be reported, otherwise, the emissions will be repeated one by one using the CISPR quasi-peak method and reported.
7. For testing above 1GHz, the emission level of the EUT in peak mode was 20dB lower than average limit (that means the emission level in average mode also complies with the limit in average mode), then peak values of EUT will be reported, otherwise, the emissions will be measured in average mode again and reported.

3.1.4 Test Setup

For radiated emissions below 30MHz

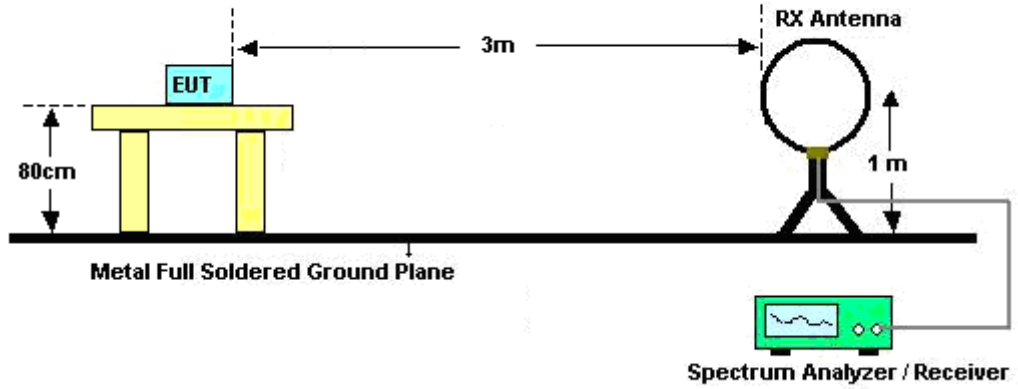

For radiated emissions from 30MHz to 1GHz

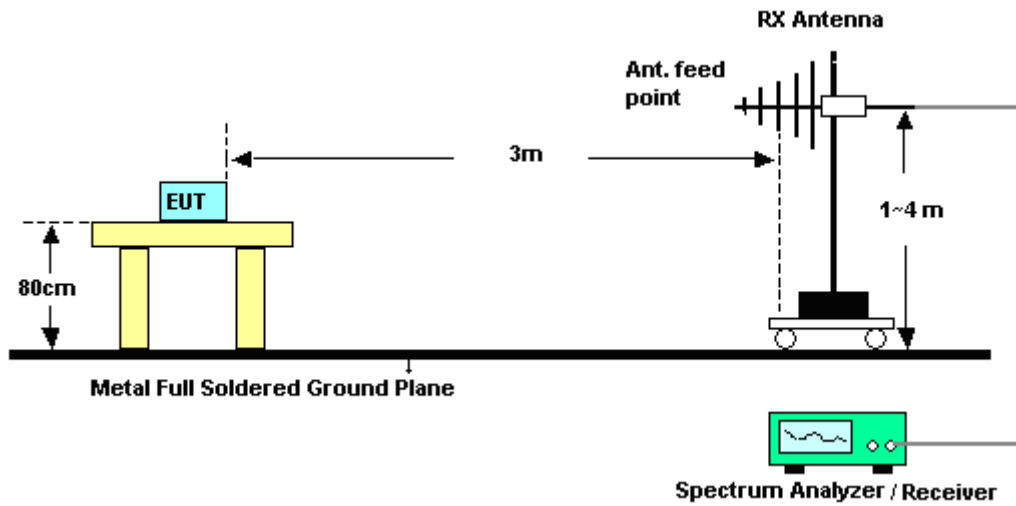

For radiated emissions above 1GHz

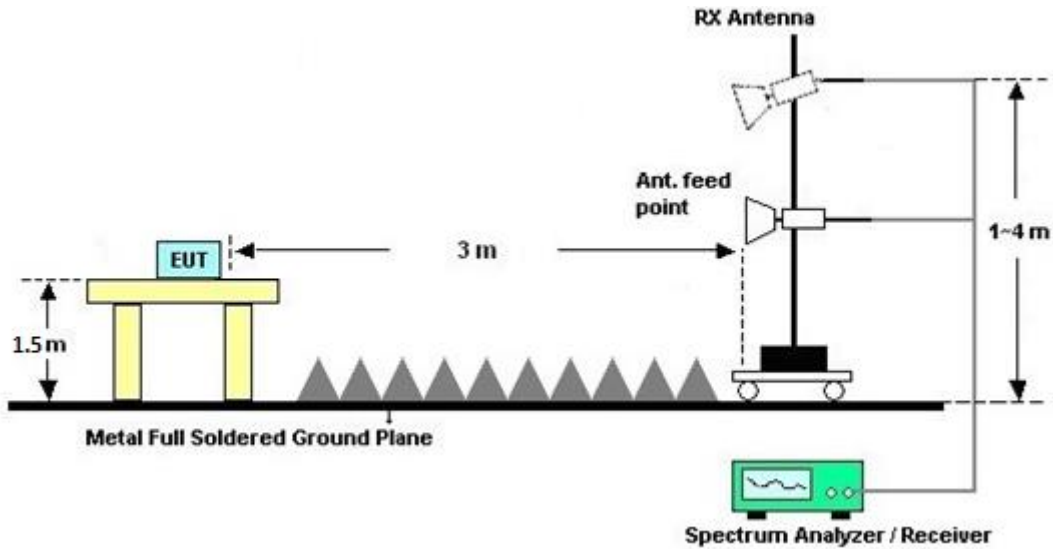

3.1.5 Test Results of Radiated Spurious Emissions (9 kHz ~ 30 MHz)

The low frequency, which started from 9 kHz to 30MHz, was pre-scanned and the result which was 20dB lower than the limit line was not reported.

There is a comparison data of both open-field test site and semi-Anechoic chamber, and the result came out very similar.

3.1.6 Test Result of Radiated Spurious at Band Edges

Please refer to Appendix A and B.

3.1.7 Duty Cycle

Please refer to Appendix C.

3.1.8 Test Result of Radiated Spurious Emissions (30MHz ~ 10th Harmonic)

Please refer to Appendix A and B.



3.2 Antenna Requirements

3.2.1 Standard Applicable

If transmitting antenna directional gain is greater than 6 dBi, both the peak transmit power and the peak power spectral density shall be reduced by the amount in dB that the directional gain of the antenna exceeds 6 dBi.

3.2.2 Antenna Anti-Replacement Construction

An embedded-in antenna design is used.

3.2.3 Antenna Gain

The antenna peak gain of EUT is less than 6 dBi. Therefore, it is not necessary to reduce maximum peak output power limit.



4 List of Measuring Equipment

Instrument	Manufacturer	Model No.	Serial No.	Characteristics	Calibration Date	Test Date	Due Date	Remark
Spectrum Analyzer	Keysight	N9010A	MY542004 86	10Hz ~ 44GHz	Oct. 12, 2016	Jul. 14, 2017 ~ Jul. 25, 2017	Oct. 11, 2017	Radiation (03CH11-HY)
EMI Test Receiver	Agilent	N9038A(MXE)	MY532900 53	20Hz to 26.5GHz	Jan. 12, 2017	Jul. 14, 2017 ~ Jul. 25, 2017	Jan. 11, 2018	Radiation (03CH11-HY)
Loop Antenna	Rohde & Schwarz	HFH2-Z2	100488	9 kHz~30 MHz	Oct. 20, 2016	Jul. 14, 2017 ~ Jul. 25, 2017	Oct. 19, 2018	Radiation (03CH11-HY)
Bilog Antenna	TESEQ	CBL 6111D&N-6-06	35414&AT- N0602	30MHz~1GHz	Oct. 15, 2016	Jul. 14, 2017 ~ Jul. 25, 2017	Oct. 14, 2017	Radiation (03CH11-HY)
Horn Antenna	SCHWARZBECK	BBHA 9120 D	9120D-132 6	1GHz ~ 18GHz	Oct. 07, 2016	Jul. 14, 2017 ~ Jul. 25, 2017	Oct. 06, 2017	Radiation (03CH11-HY)
SHF-EHF Horn Antenna	SCHWARZBECK	BBHA 9170	BBHA9170 584	18GHz- 40GHz	Nov. 08, 2016	Jul. 14, 2017 ~ Jul. 25, 2017	Nov. 07, 2017	Radiation (03CH11-HY)
Amplifier	SONOMA	310N	187312	9kHz~1GHz	Nov. 10, 2016	Jul. 14, 2017 ~ Jul. 25, 2017	Nov. 09, 2017	Radiation (03CH11-HY)
Preamplifier	Keysight	83017A	MY532700 80	1GHz~26.5GHz	Nov. 10, 2016	Jul. 14, 2017 ~ Jul. 25, 2017	Nov. 09, 2017	Radiation (03CH11-HY)
Preamplifier	MITEQ	AMF-7D-0010 1800-30-10P	1902247	1GHz~18GHz	Jun. 23, 2017	Jul. 14, 2017 ~ Jul. 25, 2017	Jun. 22, 2018	Radiation (03CH11-HY)
Preamplifier	MITEQ	TTA1840-35-H G	1887435	18GHz~40GHz	Oct. 13, 2016	Jul. 14, 2017 ~ Jul. 25, 2017	Oct. 12, 2017	Radiation (03CH11-HY)
Antenna Mast	EMEC	AM-BS-4500- B	N/A	1~4m	N/A	Jul. 14, 2017 ~ Jul. 25, 2017	N/A	Radiation (03CH11-HY)
Turn Table	EMEC	TT 2000	N/A	0~360 Degree	N/A	Jul. 14, 2017 ~ Jul. 25, 2017	N/A	Radiation (03CH11-HY)



5 Uncertainty of Evaluation

Uncertainty of Radiated Emission Measurement (30 MHz ~ 1000 MHz)

Measuring Uncertainty for a Level of Confidence of 95% ($U = 2Uc(y)$)	5.20
---	------

Uncertainty of Radiated Emission Measurement (1000 MHz ~ 18000 MHz)

Measuring Uncertainty for a Level of Confidence of 95% ($U = 2Uc(y)$)	5.50
---	------

Uncertainty of Radiated Emission Measurement (18000 MHz ~ 40000 MHz)

Measuring Uncertainty for a Level of Confidence of 95% ($U = 2Uc(y)$)	5.20
---	------



Appendix A. Radiated Spurious Emission

Test Engineer :	J.C. Liang, Jacky Huang, Ken Wu	Temperature :	20~24°C
		Relative Humidity :	50~54%

Co-location

WIFI 802.11g CDD and 15.4 (Harmonic @ 3m)

	Note	Frequency	Level	Over	Limit	Read	Antenna	Cable	Preamp	Ant	Table	Peak	Pol.
		(MHz)	(dBμV/m)	(dB)	Limit	Level	Factor	Loss	Factor	Pos	Pos	Avg.	
					Line	(dBμV)	(dB/m)	(dB)	(dB)	(cm)	(deg)	(P/A)	(H/V)
802.11g CH06		4874	47.71	-26.29	74	68.88	31.71	9.56	62.87	100	0	P	H
2437MHz and 15.4 CH18 2440MHz		7311	43.52	-30.48	74	57.01	37.43	11.31	62.69	100	0	P	H
		4874	48.71	-25.29	74	70.31	31.71	9.56	62.87	100	0	P	V
		7311	44.52	-29.48	74	58.47	37.43	11.31	62.69	100	0	P	V

Remark	1. No other spurious found.
	2. All results are PASS against Peak and Average limit line.



WIFI 802.11a CDD and 15.4 (Harmonic @ 3m)

	Note	Frequency (MHz)	Level (dBµV/m)	Over Limit (dB)	Limit Line (dBµV/m)	Read Level (dBµV)	Antenna Factor (dB/m)	Cable Loss (dB)	Preamp Factor (dB)	Ant Pos (cm)	Table Pos (deg)	Peak Avg. (P/A)	Pol. (H/V)
802.11a CH64 5320MHz and 15.4 CH18 2440MHz		4880	57.04	-16.96	74	49.39	31.71	9.01	33.07	100	254	P	H
		4880	48.02	-5.98	54	40.37	31.71	9.01	33.07	100	254	A	H
		10640	53.11	-20.89	74	63.29	38.77	14.82	64.07	100	243	P	H
		10640	43.73	-10.27	54	53.91	38.77	14.82	64.07	100	243	A	H
		15960	48.72	-25.28	74	54.87	36.02	18.3	60.73	100	0	P	H
		4880	57.67	-16.33	74	50.02	31.71	9.01	33.07	102	286	P	V
		4880	49.91	-4.09	54	42.26	31.71	9.01	33.07	102	286	A	V
		10640	49.49	-24.51	74	59.97	38.77	14.82	64.07	100	0	P	V
		15960	47.74	-26.26	74	53.89	36.02	18.3	60.73	100	0	P	V
Remark	1. No other spurious found. 2. All results are PASS against Peak and Average limit line.												



BLE and 15.4 (Harmonic @ 3m)

	Note	Frequency (MHz)	Level (dBμV/m)	Over Limit (dB)	Limit Line (dBμV/m)	Read Level (dBμV)	Antenna Factor (dB/m)	Cable Loss (dB)	Preamp Factor (dB)	Ant Pos (cm)	Table Pos (deg)	Peak Avg. (P/A)	Pol. (H/V)
BLE CH00 2402MHz and 15.4 CH18 2440MHz		4804	52.43	-21.57	74	73.82	31.6	9.6	63.02	100	270	P	H
		4804	50.02	-3.98	54	71.41	31.6	9.6	63.02	100	270	A	H
		4880	44.38	-29.62	74	65.55	31.71	9.56	62.87	100	0	P	H
		7320	45.3	-28.7	74	58.72	37.51	11.31	62.7	100	0	P	H
		4804	48.47	-25.53	74	70.29	31.6	9.6	63.02	100	0	P	V
		4880	48.35	-25.65	74	69.95	31.71	9.56	62.87	100	0	P	V
		7320	43.56	-30.44	74	57.44	37.51	11.31	62.7	100	0	P	V
Remark	1. No other spurious found. 2. All results are PASS against Peak and Average limit line.												



Emission below 1GHz

WIFI 802.11g CDD and 15.4 (LF @ 3m)

	Note	Frequency	Level	Over	Limit	Read	Antenna	Cable	Preamp	Ant	Table	Peak	Pol.
		(MHz)	(dBμV/m)	(dB)	(dBμV/m)	(dBμV)	(dB/m)	(dB)	(dB)	(cm)	(deg)	(P/A)	(H/V)
802.11g CH06 2437MHz and 15.4 CH18 2440MHz		30	22.41	-17.59	40	29.7	24.36	0.82	32.5	-	-	P	H
		129.09	29.79	-13.71	43.5	43.07	17.61	1.51	32.45	-	-	P	H
		149.07	31.05	-12.45	43.5	44.72	17.08	1.61	32.44	100	85	P	H
		399.4	26.92	-19.08	46	34.77	21.86	2.56	32.33	-	-	P	H
		749.4	30.87	-15.13	46	31.5	28.13	3.44	32.33	-	-	P	H
		955.2	33.27	-12.73	46	29.33	31.02	3.9	31.15	-	-	P	H
		32.16	26.92	-13.08	40	35.24	23.33	0.82	32.49	-	-	P	V
		41.07	26.66	-13.34	40	39.49	18.83	0.82	32.49	-	-	P	V
		59.43	24.51	-15.49	40	44.15	11.81	1.02	32.49	-	-	P	V
		442.1	27.95	-18.05	46	34.49	23.07	2.7	32.35	-	-	P	V
		718.6	29.27	-16.73	46	30.99	27.16	3.4	32.41	-	-	P	V
	944	33.44	-12.56	46	30.18	30.53	3.82	31.26	100	0	P	V	
Remark	1. No other spurious found. 2. All results are PASS against limit line.												



WIFI 802.11a CDD and 15.4 (LF @ 3m)

WIFI Ant. 1+2	Note	Frequency (MHz)	Level (dBμV/m)	Over Limit (dB)	Limit Line (dBμV/m)	Read Level (dBμV)	Antenna Factor (dB/m)	Cable Loss (dB)	Preamp Factor (dB)	Ant Pos (cm)	Table Pos (deg)	Peak Avg. (P/A)	Pol. (H/V)
802.11a CH64 5320MHz and 15.4 CH18 2440MHz		125.58	29.29	-14.21	43.5	42.65	17.54	1.51	32.46	-	-	P	H
		149.07	31.06	-12.44	43.5	44.73	17.08	1.61	32.44	-	-	P	H
		195.78	26.43	-17.07	43.5	42.2	14.86	1.69	32.39	-	-	P	H
		359.5	27.94	-18.06	46	37.13	20.64	2.48	32.35	-	-	P	H
		633.9	28.82	-17.18	46	31.61	26.42	3.15	32.46	-	-	P	H
		950.3	33.72	-12.28	46	30.11	30.82	3.82	31.2	100	0	P	H
		34.32	26.43	-13.57	40	35.79	22.3	0.82	32.49	-	-	P	V
		41.34	26.18	-13.82	40	39.56	18.28	0.82	32.49	-	-	P	V
		59.16	26.66	-13.34	40	46.3	11.81	1.02	32.49	-	-	P	V
		444.9	26.81	-19.19	46	33.3	23.12	2.7	32.35	-	-	P	V
		614.3	29.44	-16.56	46	32.78	25.94	3.09	32.46	-	-	P	V
		930	34.09	-11.91	46	31.5	29.98	3.82	31.38	100	0	P	V
Remark	<ol style="list-style-type: none"> No other spurious found. All results are PASS against limit line. 												



BLE and 15.4 (LF @ 3m)

WiFi Ant. 1+2	Note	Frequency (MHz)	Level (dBμV/m)	Over Limit (dB)	Limit Line (dBμV/m)	Read Level (dBμV)	Antenna Factor (dB/m)	Cable Loss (dB)	Preamp Factor (dB)	Ant Pos (cm)	Table Pos (deg)	Peak Avg. (P/A)	Pol. (H/V)
BLE CH00 2402MHz and 15.4 CH18 2440MHz		31.62	21.42	-18.58	40	29.74	23.33	0.82	32.49	-	-	P	H
		131.25	24.87	-18.63	43.5	38.16	17.6	1.51	32.45	-	-	P	H
		150.42	21.05	-22.45	43.5	34.74	17.05	1.61	32.43	-	-	P	H
		512.8	24.91	-21.09	46	30.23	24.1	2.91	32.39	-	-	P	H
		784.4	30.62	-15.38	46	30.89	28.32	3.49	32.23	-	-	P	H
		948.2	33.54	-12.46	46	30.04	30.73	3.82	31.22	100	0	P	H
		38.37	29.87	-10.13	40	41.68	19.85	0.82	32.49	100	184	P	V
		61.05	26.26	-13.74	40	45.98	11.73	1.02	32.49	-	-	P	V
		66.99	23.29	-16.71	40	42.72	12.03	1.02	32.49	-	-	P	V
		447	25.04	-20.96	46	31.49	23.16	2.7	32.35	-	-	P	V
		682.2	28.68	-17.32	46	31.2	26.56	3.27	32.47	-	-	P	V
		957.3	33.36	-12.64	46	29.33	31.1	3.9	31.14	-	-	P	V
Remark	1. No other spurious found. 2. All results are PASS against limit line.												



Note symbol

*	Fundamental Frequency which can be ignored. However, the level of any unwanted emissions shall not exceed the level of the fundamental frequency.
!	Test result is over limit line.
P/A	Peak or Average
H/V	Horizontal or Vertical



A calculation example for radiated spurious emission is shown as below:

WIFI	Note	Frequency	Level	Over	Limit	Read	Antenna	Cable	Preamp	Ant	Table	Peak	Pol.
Ant.				Limit	Line	Level	Factor	Loss	Factor	Pos	Pos	Avg.	
1+2		(MHz)	(dBμV/m)	(dB)	(dBμV/m)	(dBμV)	(dB/m)	(dB)	(dB)	(cm)	(deg)	(P/A)	(H/V)
802.11b		2390	55.45	-18.55	74	54.51	32.22	4.58	35.86	103	308	P	H
CH 01													
2412MHz		2390	43.54	-10.46	54	42.6	32.22	4.58	35.86	103	308	A	H

- Level(dBμV/m) =
Antenna Factor(dB/m) + Cable Loss(dB) + Read Level(dBμV) - Preamp Factor(dB)
- Over Limit(dB) = Level(dBμV/m) – Limit Line(dBμV/m)

For Peak Limit @ 2390MHz:

- Level(dBμV/m)
= Antenna Factor(dB/m) + Cable Loss(dB) + Read Level(dBμV) - Preamp Factor(dB)
= 32.22(dB/m) + 4.58(dB) + 54.51(dBμV) – 35.86 (dB)
= 55.45 (dBμV/m)
- Over Limit(dB)
= Level(dBμV/m) – Limit Line(dBμV/m)
= 55.45(dBμV/m) – 74(dBμV/m)
= -18.55(dB)

For Average Limit @ 2390MHz:

- Level(dBμV/m)
= Antenna Factor(dB/m) + Cable Loss(dB) + Read Level(dBμV) - Preamp Factor(dB)
= 32.22(dB/m) + 4.58(dB) + 42.6(dBμV) – 35.86 (dB)
= 43.54 (dBμV/m)
- Over Limit(dB)
= Level(dBμV/m) – Limit Line(dBμV/m)
= 43.54(dBμV/m) – 54(dBμV/m)
= -10.46(dB)

Both peak and average measured complies with the limit line, so test result is “PASS”.



Appendix B. Radiated Spurious Emission Plots

Test Engineer :	J.C. Liang, Jacky Huang, Ken Wu	Temperature :	20~24°C
		Relative Humidity :	50~54%

Co-location Mode

WIFI 802.11g CDD and 15.4 (Harmonic @ 3m)

Co-location mode Harmonic @ 3m		
802.11g CH06 2437MHz and 15.4 CH18 2440MHz		
	Horizontal	Vertical
Peak Avg.		



WIFI 802.11a CDD and 15.4 (Harmonic @ 3m)

Co-location mode Harmonic @ 3m		
WIFI 802.11a CH64 5320MHz and 15.4 CH18 2440MHz		
	Horizontal	Vertical
Peak Avg.	<p>Site : 103CH11-RF Condition : PEAK 74.3m 9070.54P-H-ERR6 150009-HORIZONTAL</p>	<p>Site : 103CH11-RF Condition : PEAK 74.3m 9070.54P-H-ERR6 150009-VERTICAL</p>



BLE and 15.4 (Harmonic @ 3m)

Co-location mode Harmonic @ 3m		
BLE CH00 2402MHz and 15.4 CH18 2440MHz		
	Horizontal	Vertical
Peak Avg.	<p>File: 103CH00-HV Condition: :PEAK: 74.3m 9070.54P-H-ERR68 150809-HORIZONTAL</p>	<p>File: 103CH00-HV Condition: :PEAK: 74.3m 9070.54P-H-ERR68 150809-VERTICAL</p>



Emission below 1GHz
WIFI 802.11g CDD and 15.4 (LF)

Table with 2 columns: Horizontal and Vertical. It contains two spectral plots showing emission levels (Level dBSm) vs Frequency (MHz) for QP / Peak. The plots are for Co-location mode, 802.11g CH06 2437MHz and 15.4 CH18 2440MHz LF.



WIFI 802.11a CDD and 15.4 (LF)

		Co-location mode	
		WIFI 802.11a CH64 5320MHz and 15.4 CH18 2440MHz LF	
		Horizontal	Vertical
QP / Peak		<p>Site : (03)CH14-F Condition : QP 3s SE-LOG 5310-LF ETC HORIZONTAL</p>	<p>Site : (03)CH14-F Condition : QP 3s SE-LOG 5310-LF ETC VERTICAL</p>



BLE and 15.4 (LF)

Co-location mode		
BLE CH00 2402MHz and 15.4 CH18 2440MHz LF		
	Horizontal	Vertical
QP / Peak		

Appendix C. Duty Cycle Plots

Band	Duty Cycle(%)	T(us)	1/T(kHz)	VBW Setting
15.4	15.45	2325	0.43	1kHz
Bluetooth -LE	62.18	388	2.58	3kHz

<CDD Modes>

Band	Duty Cycle(%)	T(us)	1/T(kHz)	VBW Setting
802.11g for Ant. 1	99.05	-	-	10Hz
802.11g for Ant. 2	98.57	-	-	10Hz
802.11a for Ant. 1	99.05	-	-	10Hz
802.11a for Ant. 2	98.81	-	-	10Hz

For the co-location mode, the larger VBW will apply.



15.4

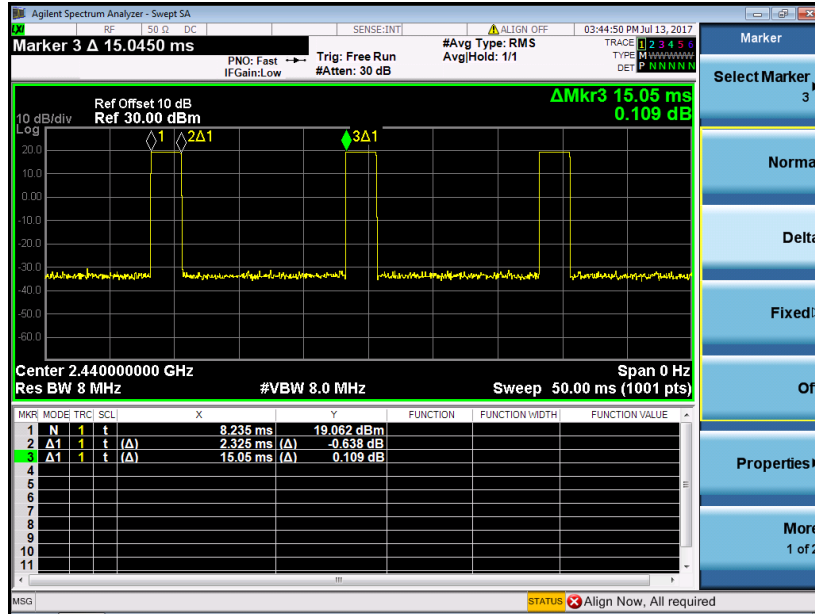

Bluetooth - LE

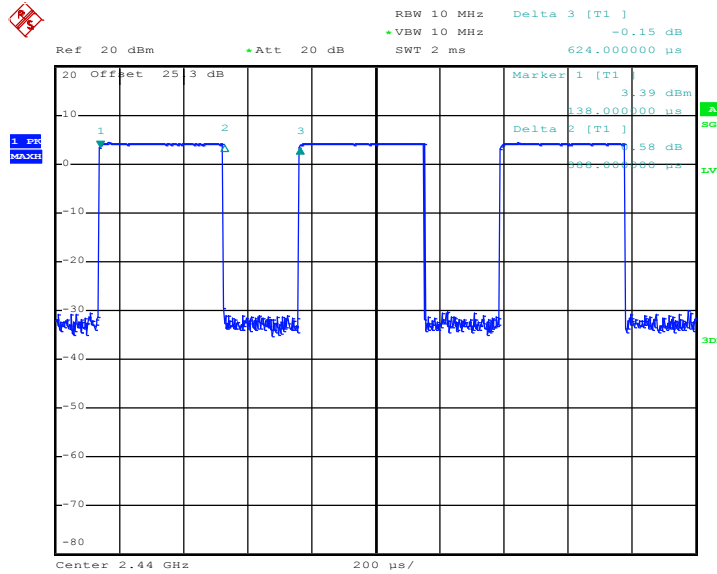

Date: 9.JUL.2017 10:30:45



MIMO <Ant. 1>

802.11g

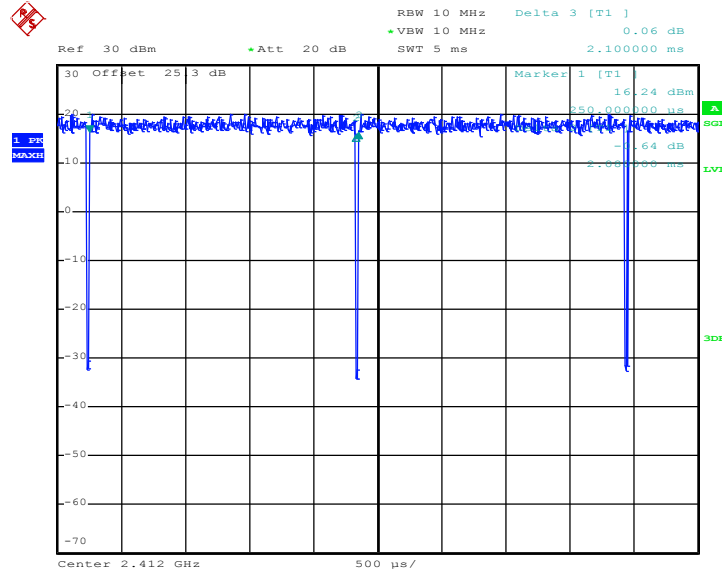

Date: 4.JUL.2017 23:20:58

802.11a

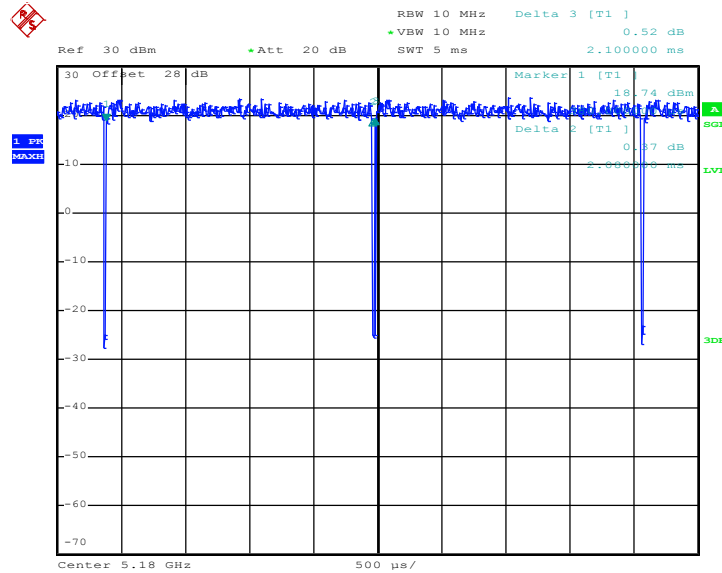

Date: 5.JUL.2017 01:09:23



MIMO <Ant. 2>

802.11g

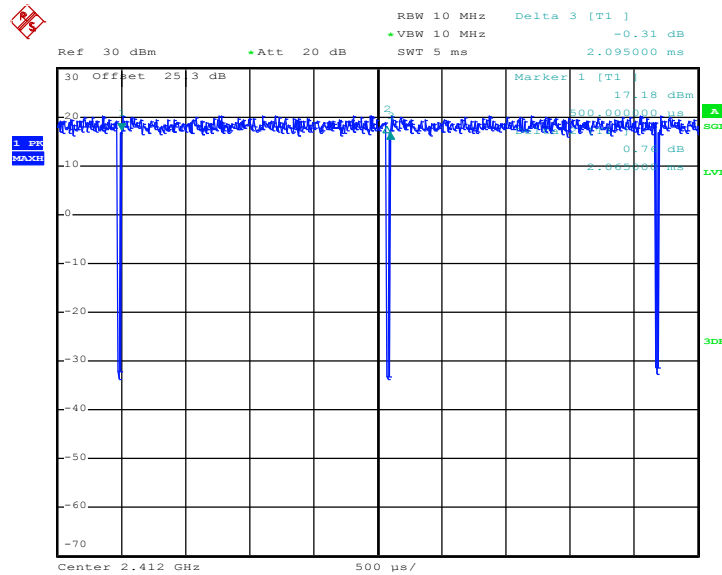

Date: 4.JUL.2017 23:21:25

802.11a

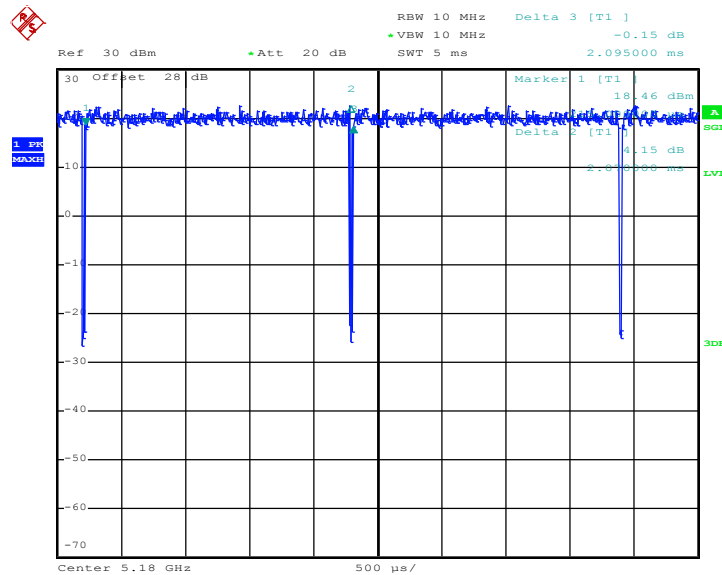

Date: 5.JUL.2017 01:09:52