



FCC RF Test Report

APPLICANT : Nest Labs Inc.
EQUIPMENT : Outdoor Security Camera
MODEL NAME : Nest Cam IQ
MODEL NUMBER : A0055
FCC ID : ZQANC41
STANDARD : FCC Part 15 Subpart C §15.247
CLASSIFICATION : (DTS) Digital Transmission System

The testing was completed on Sep. 07, 2017. We, SPORTON INTERNATIONAL INC., would like to declare that the tested sample has been evaluated in accordance with the test procedures and has been in compliance with the applicable technical standards.

The test results in this report apply exclusively to the tested model / sample. Without written approval of SPORTON INTERNATIONAL INC., the test report shall not be reproduced except in full.

Reviewed by: Joseph Lin / Supervisor

Approved by: Jones Tsai / Manager



SPORTON INTERNATIONAL INC.

No. 52, Hwa Ya 1st Rd., Hwa Ya Technology Park, Kwei-Shan District, Tao Yuan City, Taiwan, R.O.C.

SPORTON INTERNATIONAL INC.

TEL : 886-3-327-3456

FAX : 886-3-328-4978

FCC ID : ZQANC41

Page Number : 1 of 37

Report Issued Date : Sep. 08, 2017

Report Version : Rev. 02

Report Template No.: BU5-FR15C15.4 Version 1.0



TABLE OF CONTENTS

SUMMARY OF TEST RESULT 4

1 GENERAL DESCRIPTION..... 5

 1.1 Applicant 5

 1.2 Product Feature of Equipment Under Test..... 5

 1.3 Modification of EUT 5

 1.4 Testing Location 6

 1.5 Applicable Standards..... 6

2 TEST CONFIGURATION OF EQUIPMENT UNDER TEST..... 7

 2.1 Descriptions of Test Mode 7

 2.2 Test Mode 8

 2.3 Connection Diagram of Test System 9

 2.4 Support Unit used in test configuration and system 10

 2.5 EUT Operation Test Setup 10

 2.6 Measurement Results Explanation Example..... 10

3 TEST RESULT 11

 3.1 6dB and 99% Bandwidth Measurement 11

 3.2 Peak Output Power Measurement 16

 3.3 Power Spectral Density Measurement 17

 3.4 Conducted Band Edges and Spurious Emission Measurement 22

 3.5 Spurious Emission Measurement in the Restricted Band 27

 3.6 AC Conducted Emission Measurement..... 31

 3.7 Antenna Requirements 35

4 LIST OF MEASURING EQUIPMENT..... 36

5 UNCERTAINTY OF EVALUATION..... 37

APPENDIX A. CONDUCTED TEST RESULTS

APPENDIX B. CONDUCTED SPURIOUS EMISSION

APPENDIX C. CONDUCTED SPURIOUS EMISSION PLOTS

APPENDIX D. CABINET RADIATION DATA

APPENDIX E. CABINET RADIATION PLOTS

APPENDIX F. DUTY CYCLE PLOTS



REVISION HISTORY

REPORT NO.	VERSION	DESCRIPTION	ISSUED DATE
FR6N0107-01A	Rev. 01	Initial issue of report	Aug. 29, 2017
FR6N0107-01A	Rev. 02	Revising conducted emission test mode in section 2.3 and connection diagram of test system in section 2.4.	Sep. 05, 2017
FR6N0107-01A	Rev. 02	Revising conducted emission data in section 3.6.5 and connection diagram of test system in section 2.3 and updating setup photographs.	Sep. 08, 2017
FR6N0107-01A	Rev. 02	Revising conducted emission test mode in section 2.2 and connection diagram of test system in section 2.3 and updating setup photographs.	Sep. 08, 2017



SUMMARY OF TEST RESULT

Report Section	FCC Rule	Description	Limit	Result
3.1	15.247(a)(2)	6dB Bandwidth	$\geq 0.5\text{MHz}$	Pass
3.1	-	99% Bandwidth	-	Pass
3.2	15.247(b)(3)	Peak Output Power	$\leq 30\text{dBm}$	Pass
3.3	15.247(e)	Power Spectral Density	$\leq 8\text{dBm}/3\text{kHz}$	Pass
3.4	15.247(d)	Conducted Band Edges and Spurious Emission	$\leq 20\text{dBc}$	Pass
3.5	15.247(d)	Radiated Band Edges and Spurious Emission	15.209(a) & 15.247(d)	Pass
3.6	15.207	AC Conducted Emission	15.207(a)	Pass
3.7	15.203 & 15.247(b)	Antenna Requirement	N/A	Pass



1 General Description

1.1 Applicant

Nest Labs Inc.
3400 Hillview Ave.Palo Alto, CA 94304 USA

1.2 Product Feature of Equipment Under Test

Bluetooth-LE, Wi-Fi 2.4GHz 802.11b/g/n/ac, and Wi-Fi 5GHz 802.11a/n/ac, 15.4

Product Specification subjective to this standard	
Antenna Type	WLAN: IFA Antenna Bluetooth: IFA Antenna 15.4: IFA Antenna

1.3 Modification of EUT

No modifications are made to the EUT during all test items.



1.4 Testing Location

Sporton Lab is accredited to ISO 17025 by Taiwan Accreditation Foundation (TAF code : 1190) and the FCC designation No. TW0007 under the FCC 2.948(e) by Mutual Recognition Agreement (MRA) in FCC Test.

Test Site	SPORTON INTERNATIONAL INC.	
Test Site Location	No. 52, Hwa Ya 1 st Rd., Hwa Ya Technology Park, Kwei-Shan District, Tao Yuan City, Taiwan, R.O.C. TEL: +886-3-327-3456 FAX: +886-3-328-4978	
Test Site No.	Sporton Site No.	
	TH05-HY	CO05-HY

Note: The test site complies with ANSI C63.4 2014 requirement.

Test Site	SPORTON INTERNATIONAL INC.	
Test Site Location	No.58, Aly. 75, Ln. 564, Wenhua 3rd Rd. Guishan Dist, Taoyuan City, Taiwan (R.O.C.) TEL: +886-3-327-0868 FAX: +886-3-327-0855	
Test Site No.	Sporton Site No.	
	03CH11-HY	03CH15-HY

Note: The test site complies with ANSI C63.4 2014 requirement.

1.5 Applicable Standards

According to the specifications of the manufacturer, the EUT must comply with the requirements of the following standards:

- ♦ FCC Part 15 Subpart C §15.247
- ♦ FCC KDB Publication No. 558074 D01 DTS Meas. Guidance v04
- ♦ ANSI C63.10-2013

Remark: All test items were verified and recorded according to the standards and without any deviation during the test.



2 Test Configuration of Equipment Under Test

2.1 Descriptions of Test Mode

The RF output power was recorded in the following table:

Channel	Frequency	15.4 RF Output Power
		Data Rate / Modulation
		BPSK/QPSK
		250kbps
Ch11	2405MHz	20.27 dBm
Ch18	2440MHz	20.73 dBm
Ch25	2475MHz	9.96 dBm

- a. The EUT has been associated with peripherals and configuration operated in a manner tended to maximize its emission characteristics in a typical application. Frequency range investigated: conduction (150 kHz to 30 MHz), radiation (9 kHz to the 10th harmonic of the highest fundamental frequency or to 40 GHz, whichever is lower). For radiated measurement, pre-scanned in four orthogonal panels, X, Y, Z, Back. The worst cases (X plane) were recorded in this report.

- b. AC power line Conducted Emission was tested under maximum output power.



2.2 Test Mode

The following summary table is showing all test modes to demonstrate in compliance with the standard.

Summary table of Test Cases	
Test Item	Data Rate / Modulation
	250kbps / 15.4
Conducted TCs	Mode 1: 15.4 Tx CH11_2405 MHz
	Mode 2: 15.4 Tx CH18_2440 MHz
	Mode 3: 15.4 Tx CH25_2475 MHz
Radiated TCs	Mode 1: 15.4 Tx CH11_2405 MHz
	Mode 2: 15.4 Tx CH18_2440 MHz
	Mode 3: 15.4 Tx CH25_2475 MHz
AC Conducted Emission	Mode 1 :WLAN Tx + 15.4 Tx + Speaker on + LED on + RR LED on + IR CUT on + Memory + Camera on + USB Cable (Charging from Adapter 1)
Remark: For radiated spurious emissions, the tests were performed with USB Cable and Adapter 1.	

2.3 Connection Diagram of Test System

<15.4 Tx Mode>

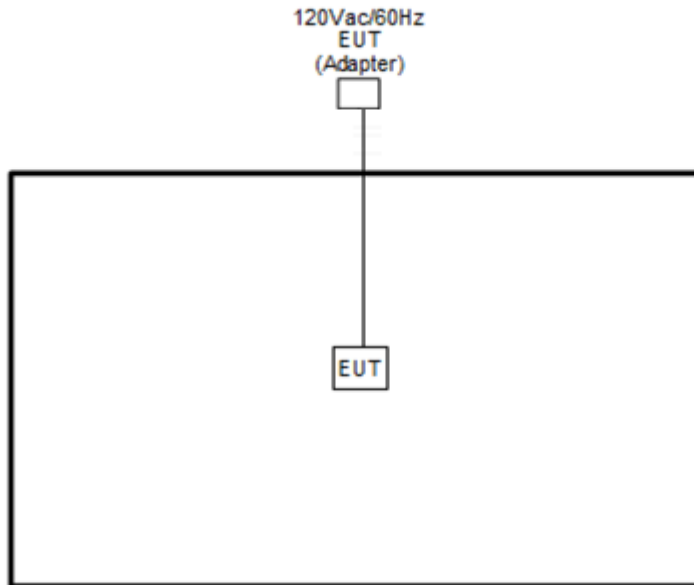

<AC Conducted Emission Mode>

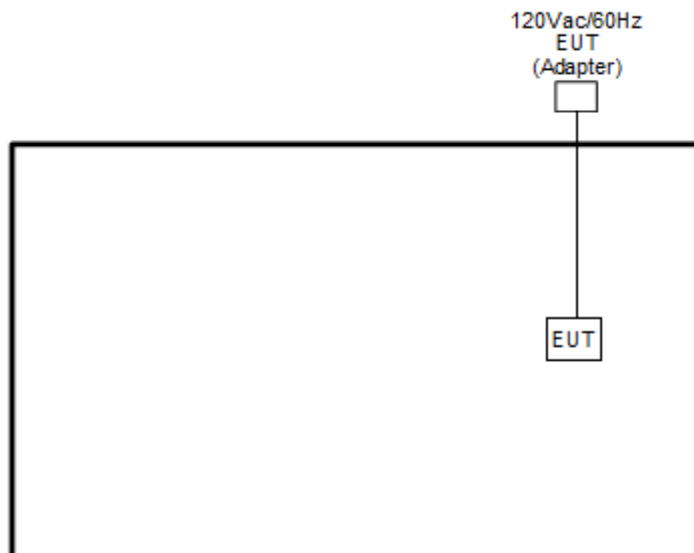

2.4 Support Unit used in test configuration and system

Item	Equipment	Trade Name	Model Name	FCC ID	Data Cable	Power Cord
1.	WLAN AP	ASUS	RT-AC66U	MSQ-RTAC66U	N/A	Unshielded, 1.8m
2.	iPod	Apple	A1285	DoC	Shielded, 1.0m	N/A
3.	Notebook	DELL	Latitude E6320	FCC DoC/ Contains FCC ID: QDS-BRCM1054	N/A	AC I/P: Unshielded, 1.2 m DC O/P: Shielded, 1.8 m
4.	USB Cable	N/A	N/A	N/A	Unshielded, 1.93 m	Unshielded, 1.93 m

2.5 EUT Operation Test Setup

For 15.4 function, programmed RF utility, "CMD" installed in the notebook make the EUT provide functions like channel selection and power level for continuous transmitting and receiving signals.

The laptop used for engineering setting purpose only was removed from the EUT, after configured.

2.6 Measurement Results Explanation Example

For all conducted test items:

The offset level is set in the spectrum analyzer to compensate the RF cable loss and attenuator factor between EUT conducted output port and spectrum analyzer. With the offset compensation, the spectrum analyzer reading level is exactly the EUT RF output level.

Example :

The spectrum analyzer offset is derived from RF cable loss and attenuator factor.

Offset = RF cable loss + attenuator factor.

Following shows an offset computation example with cable loss 4.2 dB and 10dB attenuator.

$$\begin{aligned}
 \text{Offset(dB)} &= \text{RF cable loss(dB)} + \text{attenuator factor(dB)}. \\
 &= 4.2 + 10 = 14.2 \text{ (dB)}
 \end{aligned}$$

3 Test Result

3.1 6dB and 99% Bandwidth Measurement

3.1.1 Limit of 6dB and 99% Bandwidth

The minimum 6 dB bandwidth shall be at least 500 kHz.

3.1.2 Measuring Instruments

The section 4.0 of List of Measuring Equipment of this test report is used for test.

3.1.3 Test Procedures

1. The testing follows FCC KDB Publication No. 558074 D01 DTS Meas. Guidance v04.
2. The RF output of EUT was connected to the spectrum analyzer by RF cable and attenuator. The path loss was compensated to the results for each measurement.
3. Set to the maximum power setting and enable the EUT transmit continuously.
4. Make the measurement with the spectrum analyzer's resolution bandwidth (RBW) = 100 kHz. Set the Video bandwidth (VBW) = 300 kHz. In order to make an accurate measurement. The 6 dB bandwidth must be greater than 500 kHz.
5. For 99% Bandwidth Measurement, the spectrum analyzer's resolution bandwidth (RBW) is set 30kHz and set the Video bandwidth (VBW) = 100kHz.
6. Measure and record the results in the test report.

3.1.4 Test Setup





3.1.5 Test Result of 6dB Bandwidth

Test data refer to Appendix A.

6 dB Bandwidth Plot on Channel 11

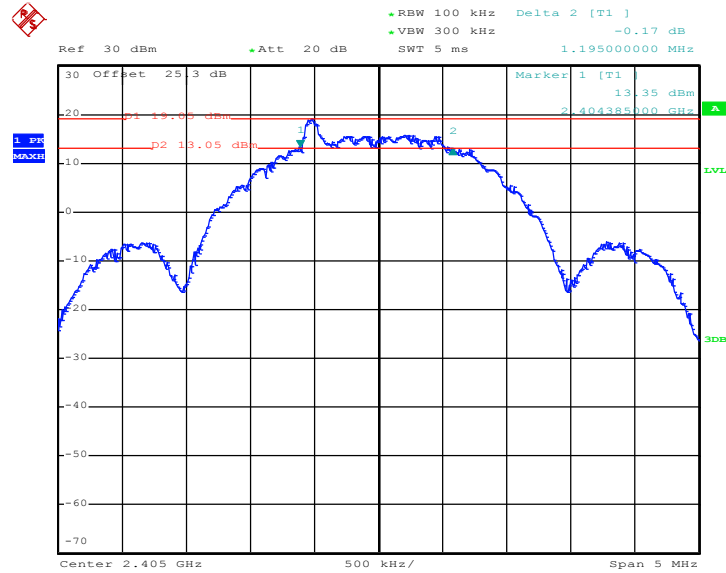

Date: 21.JUL.2017 21:10:31



6 dB Bandwidth Plot on Channel 18

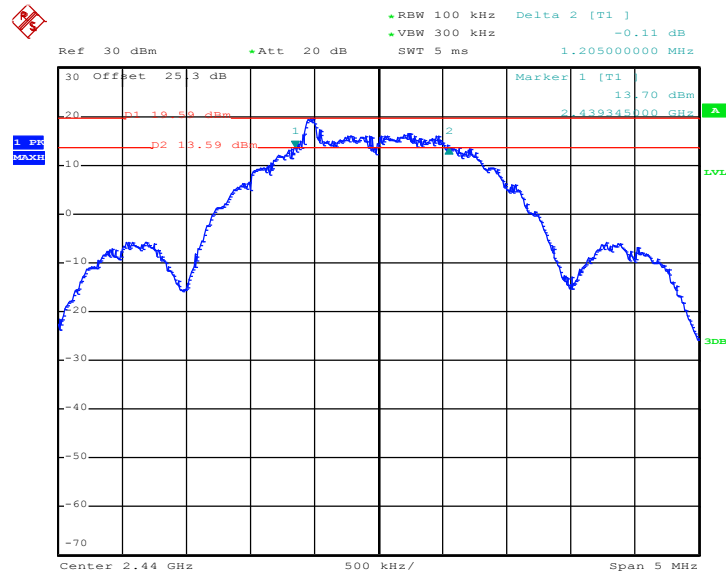

Date: 21.JUL.2017 20:55:12

6 dB Bandwidth Plot on Channel 25

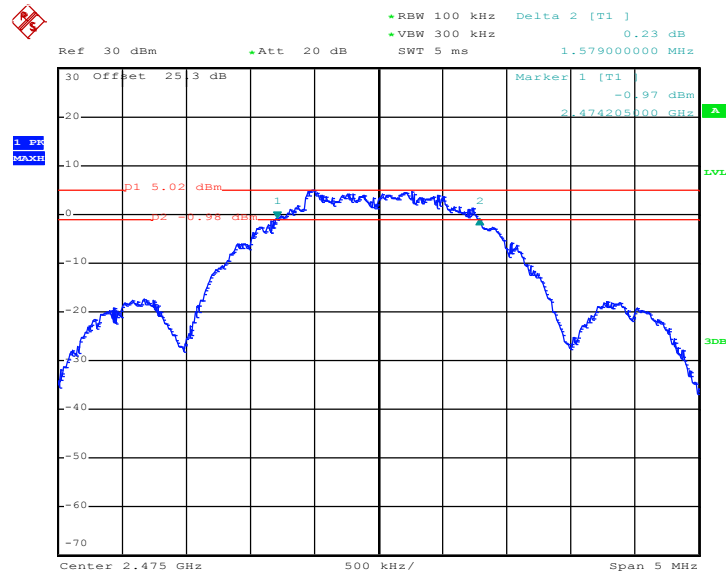

Date: 21.JUL.2017 21:23:05



3.1.6 Test Result of 99% Occupied Bandwidth

Test data refer to Appendix A.

99% Bandwidth Plot on Channel 11

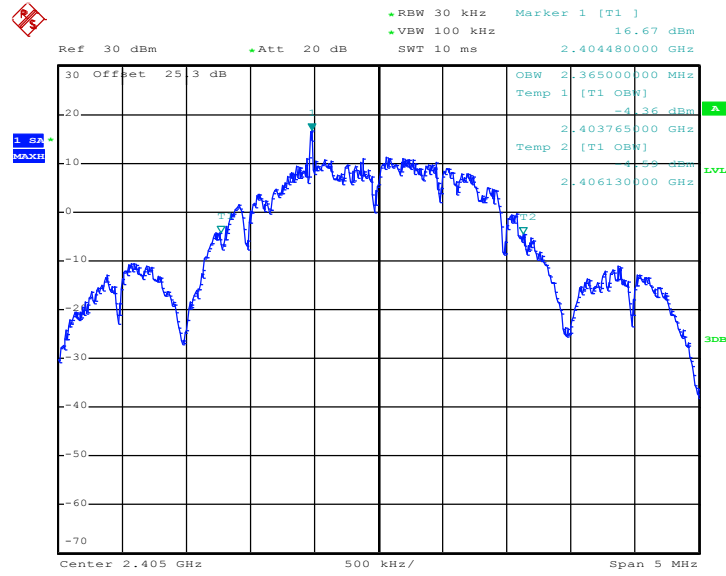

Date: 21.JUL.2017 21:20:48



99% Occupied Bandwidth Plot on Channel 18

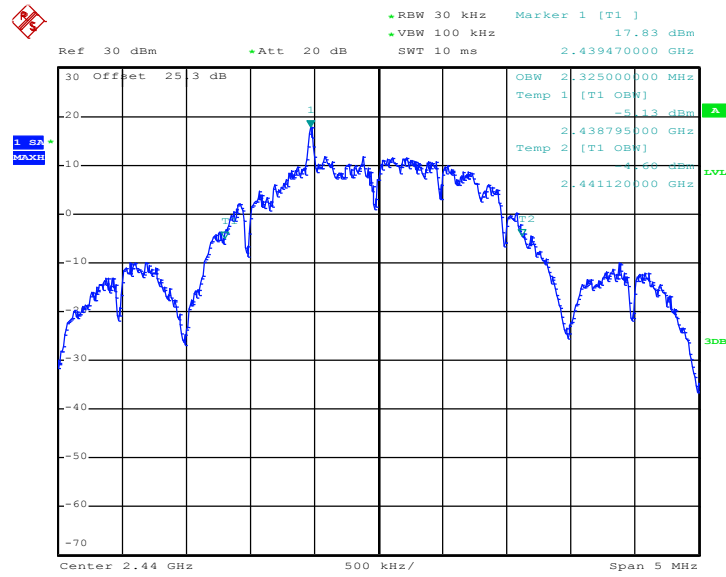

Date: 21.JUL.2017 21:08:16

99% Occupied Bandwidth Plot on Channel 25

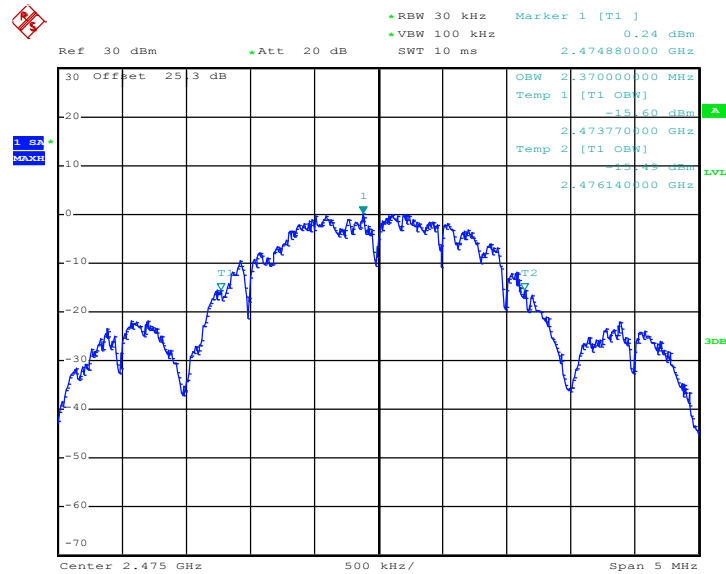

Date: 21.JUL.2017 21:37:43

Note : The occupied channel bandwidth is maintained within the band of operation for all of the modulations.

3.2 Peak Output Power Measurement

3.2.1 Limit of Peak Output Power

For systems using digital modulation in the 2400-2483.5MHz, the limit for peak output power is 30dBm. If transmitting antenna of directional gain greater than 6dBi is used, the peak output power from the intentional radiator shall be reduced below the above stated value by the amount in dB that the directional gain of the antenna exceeds 6 dBi. In case of point-to-point operation, the limit has to be reduced by 1dB for every 3dB that the directional gain of the antenna exceeds 6dBi.

3.2.2 Measuring Instruments

The section 4.0 of List of Measuring Equipment of this test report is used for test.

3.2.3 Test Procedures

1. The testing follows the Measurement Procedure of FCC KDB No. 558074 DTS D01 Meas. Guidance v04 section 9.1.3 PKPM1 Peak power meter method.
2. The RF output of EUT was connected to the power meter by RF cable and attenuator. The path loss was compensated to the results for each measurement.
3. Set to the maximum power setting and enable the EUT transmit continuously.
4. Measure the conducted output power and record the results in the test report.

3.2.4 Test Setup

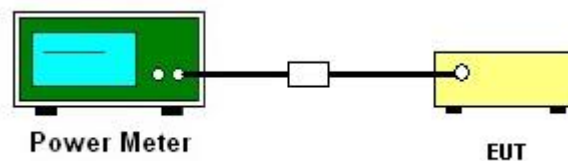

3.2.5 Test Result of Peak Output Power

Test data refers to Appendix A.

3.3 Power Spectral Density Measurement

3.3.1 Limit of Power Spectral Density

The peak power spectral density shall not be greater than 8dBm in any 3kHz band at any time interval of continuous transmission.

3.3.2 Measuring Instruments

The section 4.0 of List of Measuring Equipment of this test report is used for test.

3.3.3 Test Procedures

1. The testing follows Measurement Procedure 10.2 Method PKPSD of FCC KDB Publication No. 558074 D01 DTS Meas. Guidance v04
2. The RF output of EUT was connected to the spectrum analyzer by RF cable and attenuator. The path loss was compensated to the results for each measurement.
3. Set to the maximum power setting and enable the EUT transmit continuously.
4. Make the measurement with the spectrum analyzer's resolution bandwidth (RBW) = 3 kHz. Video bandwidth VBW = 10 kHz In order to make an accurate measurement, set the span to 1.5 times DTS Channel Bandwidth. (6dB BW)
5. Detector = peak, Sweep time = auto couple, Trace mode = max hold, Allow trace to fully stabilize. Use the peak marker function to determine the maximum power level.
6. Measure and record the results in the test report.
7. The Measured power density (dBm)/ 100kHz is a reference level and used as 20dBc down limit line for Conducted Band Edges and Conducted Spurious Emission.

3.3.4 Test Setup

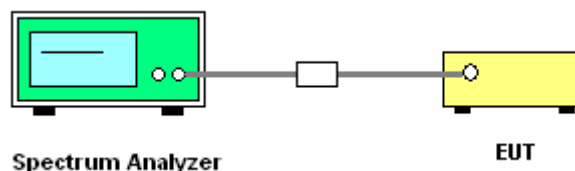

3.3.5 Test Result of Power Spectral Density

Test data refers to Appendix A.



3.3.6 Test Result of Power Spectral Density Plots (100kHz)

PSD 100kHz Plot on Channel 11

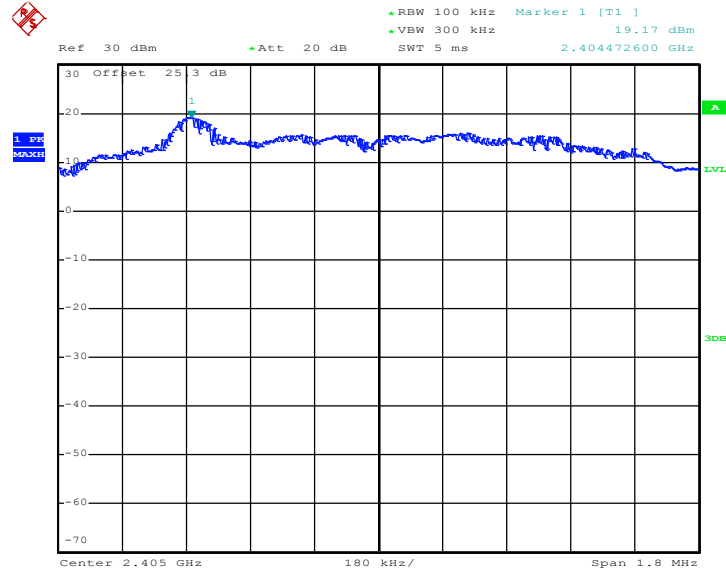

Date: 21.JUL.2017 21:16:45



PSD 100kHz Plot on Channel 18

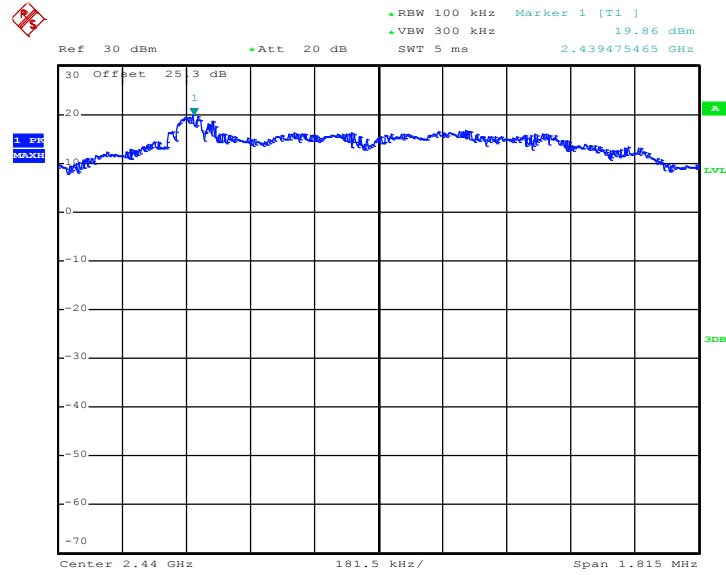

Date: 21.JUL.2017 20:56:04

PSD 100kHz Plot on Channel 25

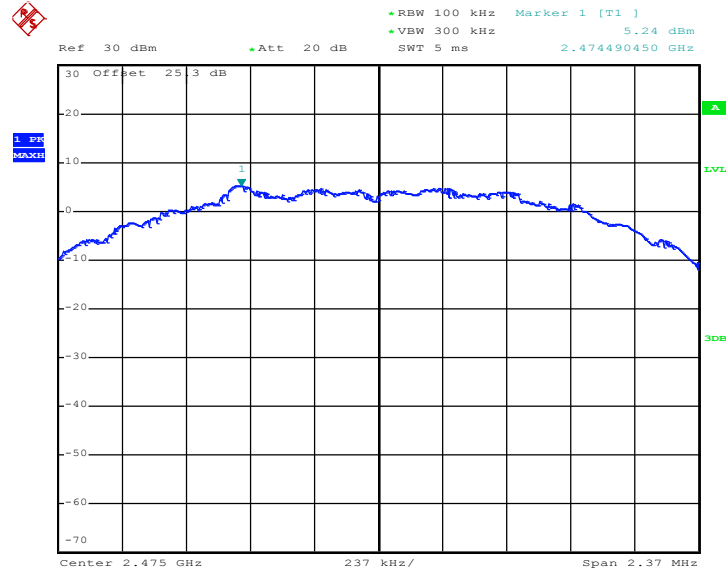

Date: 21.JUL.2017 21:25:07



3.3.7 Test Result of Power Spectral Density Plots (3kHz)

PSD 3kHz Plot on Channel 11

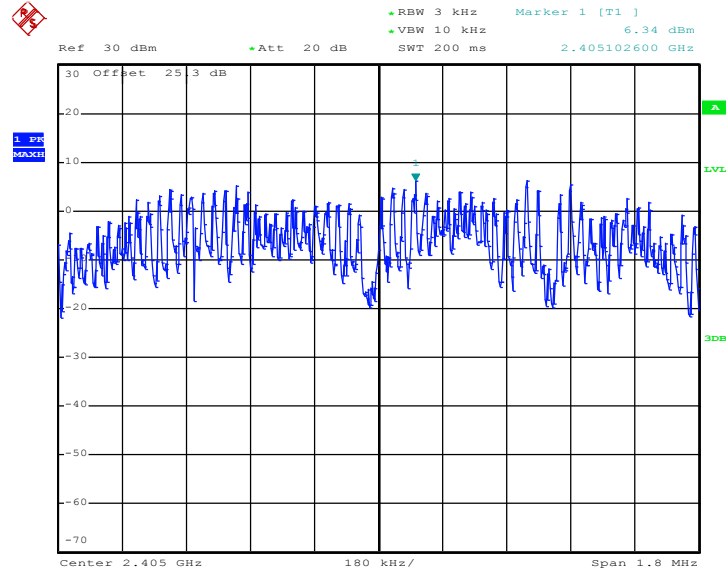

Date: 21.JUL.2017 21:16:09



PSD 3kHz Plot on Channel 18

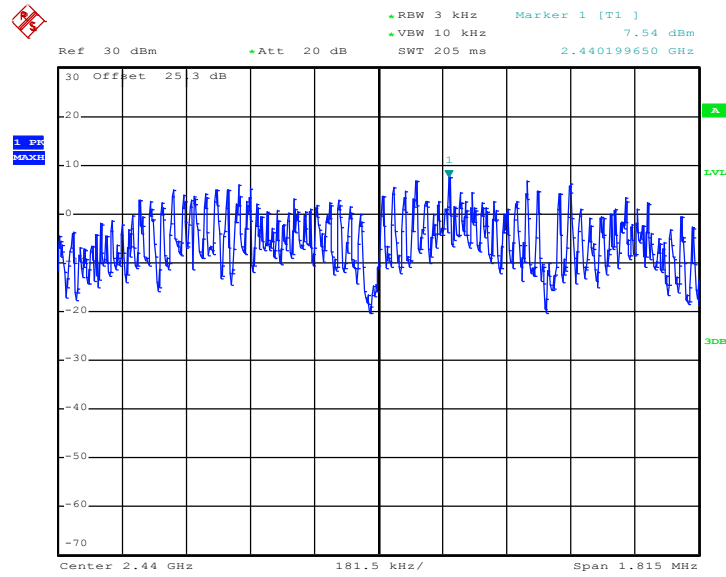

Date: 21.JUL.2017 20:55:37

PSD 3kHz Plot on Channel 25

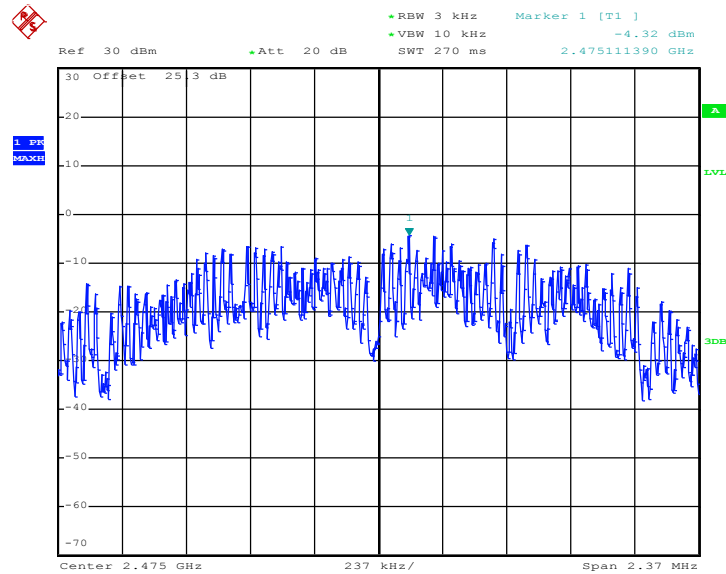

Date: 21.JUL.2017 21:23:43

3.4 Conducted Band Edges and Spurious Emission Measurement

3.4.1 Limit of Conducted Band Edges and Spurious Emission

All harmonics/spurious must be at least 20 dB down from the highest emission level within the authorized band.

3.4.2 Measuring Instruments

The section 4.0 of List of Measuring Equipment of this test report is used for test.

3.4.3 Test Procedure

1. The testing follows FCC KDB Publication No. 558074 D01 DTS Meas. Guidance v04.
2. The RF output of EUT was connected to the spectrum analyzer by RF cable and attenuator. The path loss was compensated to the results for each measurement.
3. Set to the maximum power setting and enable the EUT transmit continuously.
4. Set RBW = 100 kHz, VBW=300 kHz, Peak Detector. Unwanted Emissions measured in any 100 kHz bandwidth outside of the authorized frequency band shall be attenuated by at least 20 dB relative to the maximum in-band peak PSD level in 100 kHz when maximum peak conducted output power procedure is used. If the transmitter complies with the conducted power limits based on the use of RMS averaging over a time interval, the attenuation required under this paragraph shall be 30 dB instead of 20 dB.
5. Measure and record the results in the test report.
6. The RF fundamental frequency should be excluded against the limit line in the operating frequency band.

3.4.4 Test Setup





3.4.5 Test Result of Conducted Band Edges Plots

Low Band Edge Plot on Channel 11

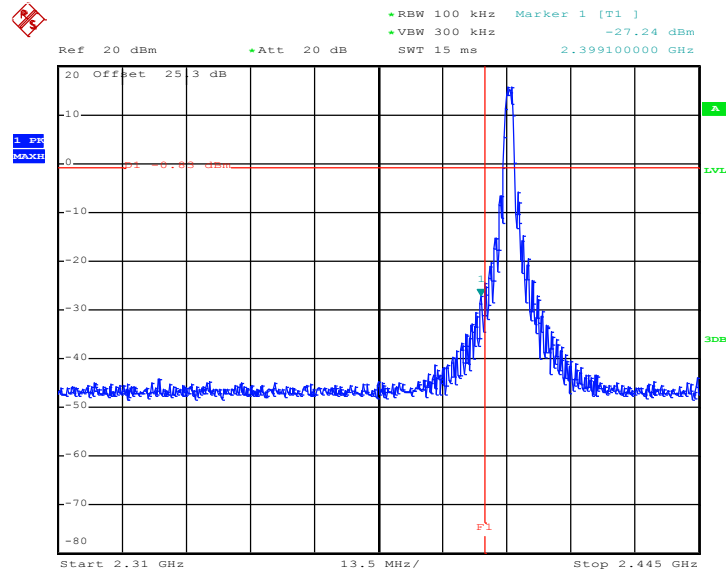

Date: 21.JUL.2017 21:18:11

High Band Edge Plot on Channel 25

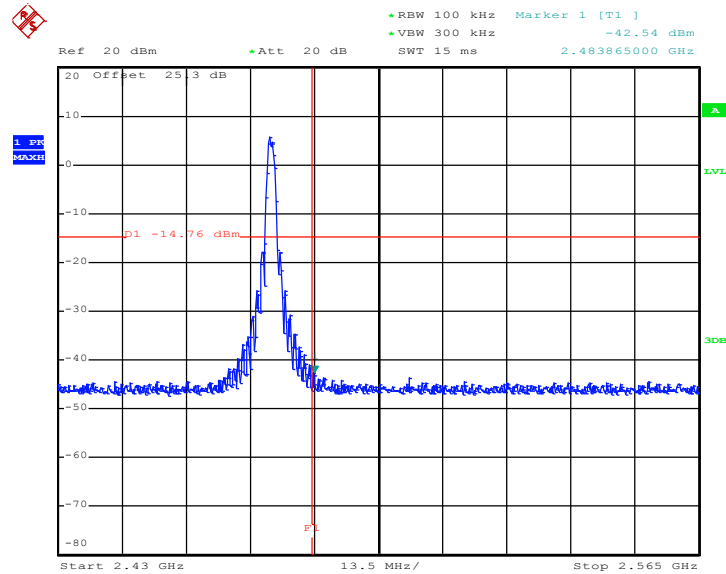

Date: 21.JUL.2017 21:30:24



3.4.6 Test Result of Conducted Spurious Emission Plots

Conducted Spurious Emission Plot on 15.4 Channel 11

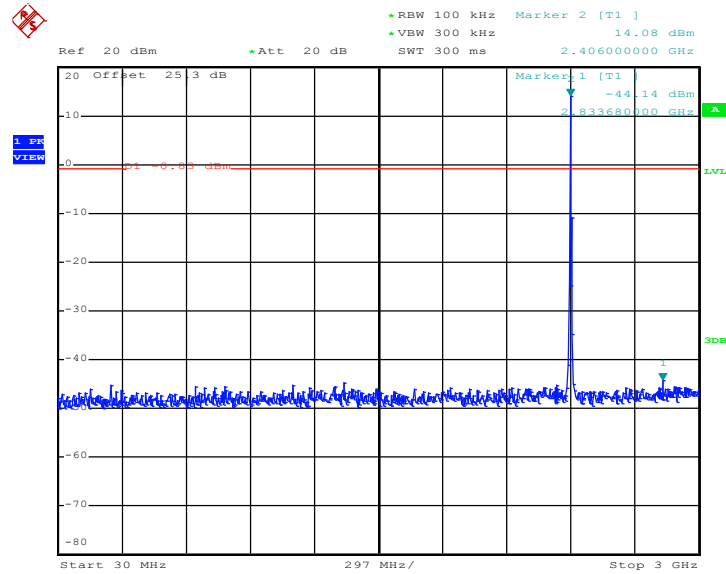

Date: 21.JUL.2017 21:19:51

Conducted Spurious Emission Plot on 15.4 Channel 11

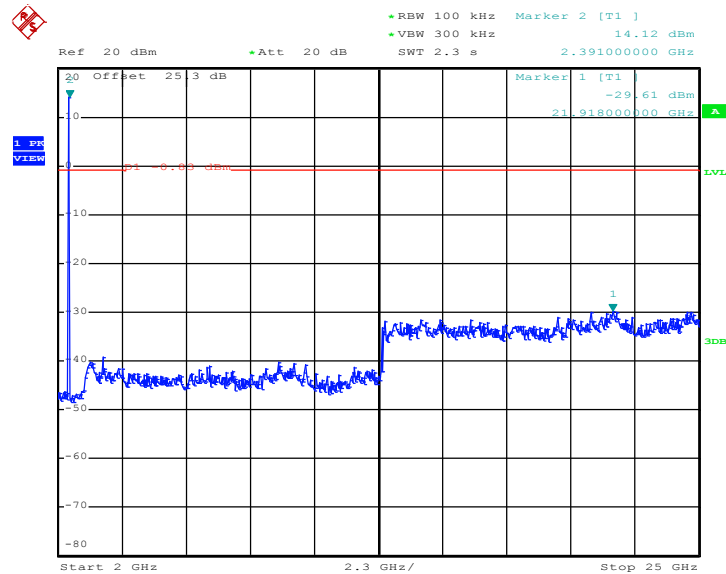

Date: 21.JUL.2017 21:19:39



Conducted Spurious Emission Plot on 15.4 Channel 18

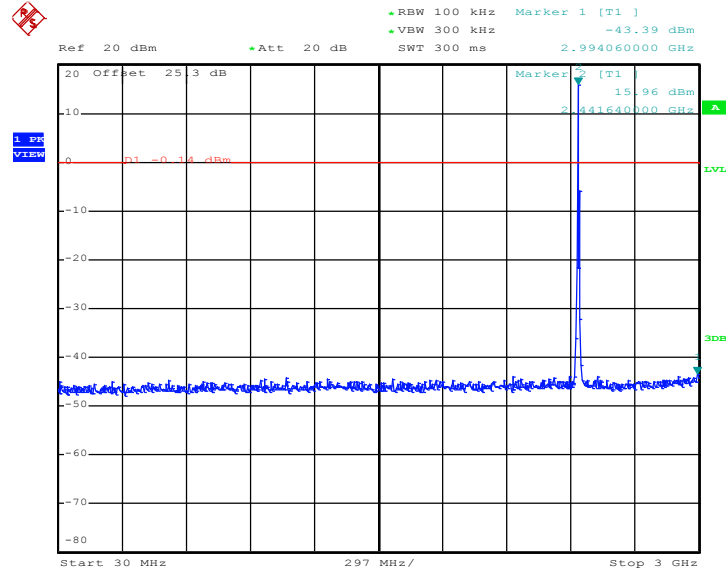

Date: 21.JUL.2017 21:05:07

Conducted Spurious Emission Plot on 15.4 Channel 18

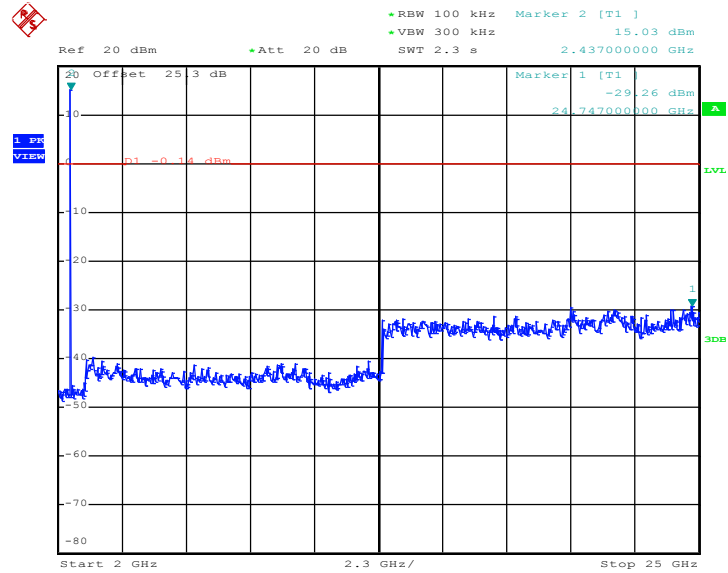

Date: 21.JUL.2017 20:57:31



Conducted Spurious Emission Plot on 15.4 Channel 25

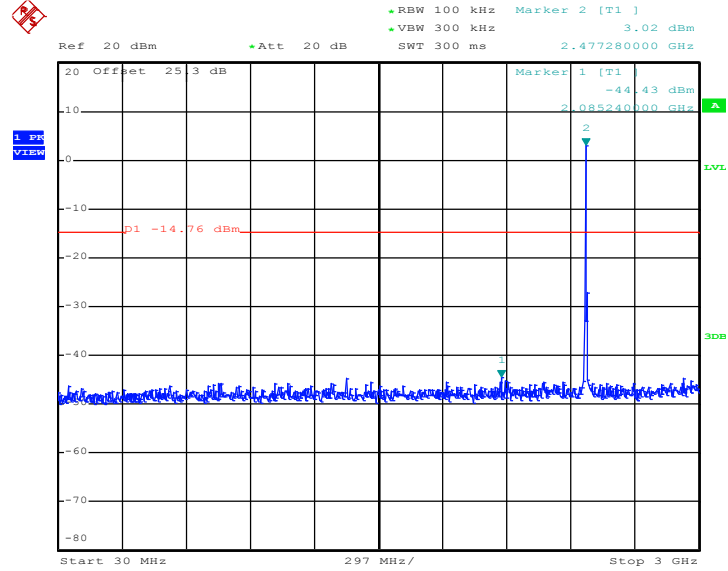

Date: 21.JUL.2017 21:31:05

Conducted Spurious Emission Plot on 15.4 Channel 25

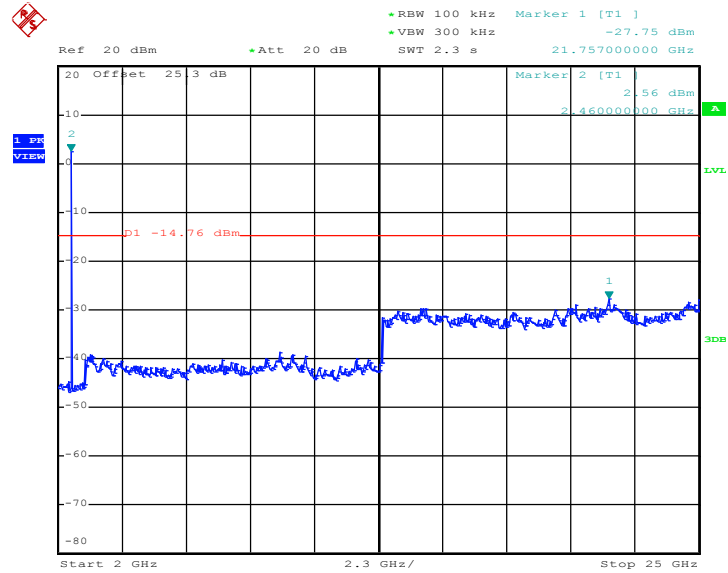

Date: 21.JUL.2017 21:33:45



3.5 Spurious Emission Measurement in the Restricted Band

3.5.1 Limit of Spurious Emission Measurement in the Restricted Band

Emissions which fall in the restricted bands must also comply with the limits as below.

Frequency (MHz)	Field Strength (microvolts/meter)	Measurement Distance (meters)
0.009 – 0.490	2400/F(kHz)	300
0.490 – 1.705	24000/F(kHz)	30
1.705 – 30.0	30	30
30 – 88	100	3
88 – 216	150	3
216 - 960	200	3
Above 960	500	3

3.5.2 Measuring Instruments

The section 4.0 of List of Measuring Equipment of this test report is used for test.



3.5.3 Test Procedures

1. The testing follows FCC KDB Publication No. 558074 D01 DTS Meas. Guidance v04
2. The EUT was arranged to its worst case and then tune the antenna tower (from 1 m to 4 m) and turntable (from 0 degree to 360 degrees) to find the maximum reading. A pre-amp and a high pass filter are used for the test in order to get better signal level.
3. The EUT was placed on a turntable with 0.8 meter for frequency below 1GHz and 1.5 meter for frequency above 1GHz respectively above ground.
4. The EUT was set 3 meters from the interference receiving antenna, which was mounted on the top of a variable height antenna tower.
5. Corrected Reading: Antenna Factor + Cable Loss + Read Level - Preamp Factor = Level
6. For conducted spurious emission measurement in the restricted band, the RF output of EUT was connected to the spectrum analyzer by RF cable and attenuator. The path loss was compensated to the results for each measurement.
7. For testing below 1GHz, if the emission level of the EUT in peak mode was 3 dB lower than the limit specified, then peak values of EUT will be reported, otherwise, the emissions will be repeated one by one using the CISPR quasi-peak method and reported.
8. For testing above 1GHz, the emission level of the EUT in peak mode was 20dB lower than average limit (that means the emission level in average mode also complies with the limit in average mode), then peak values of EUT will be reported, otherwise, the emissions will be measured in average mode again and reported.
9. Use the following spectrum analyzer settings:
 - (1) Span shall wide enough to fully capture the emission being measured;
 - (2) Set RBW=100 kHz for $f < 1$ GHz; $VBW \geq RBW$; Sweep = auto; Detector function = peak; Trace = max hold;
 - (3) Set RBW = 1 MHz, VBW= 3MHz for $f \geq 1$ GHz for peak measurement.
For average measurement:
 - $VBW = 10$ Hz, when duty cycle is no less than 98 percent.
 - $VBW \geq 1/T$, when duty cycle is less than 98 percent where T is the minimum transmission duration over which the transmitter is on and is transmitting at its maximum power control level for the tested mode of operation.

3.5.4 Test Setup

For Conducted Measurement:

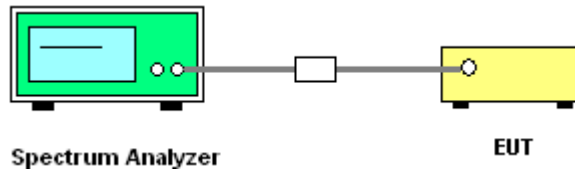

For radiated emissions below 30MHz

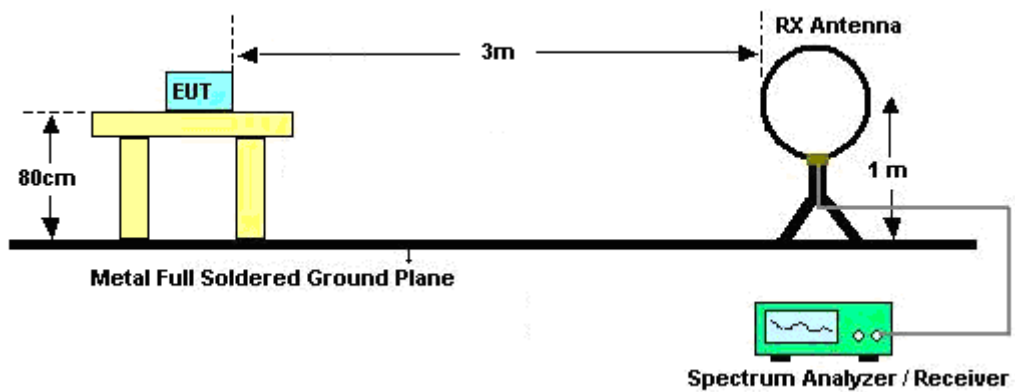

For radiated emissions from 30MHz to 1GHz

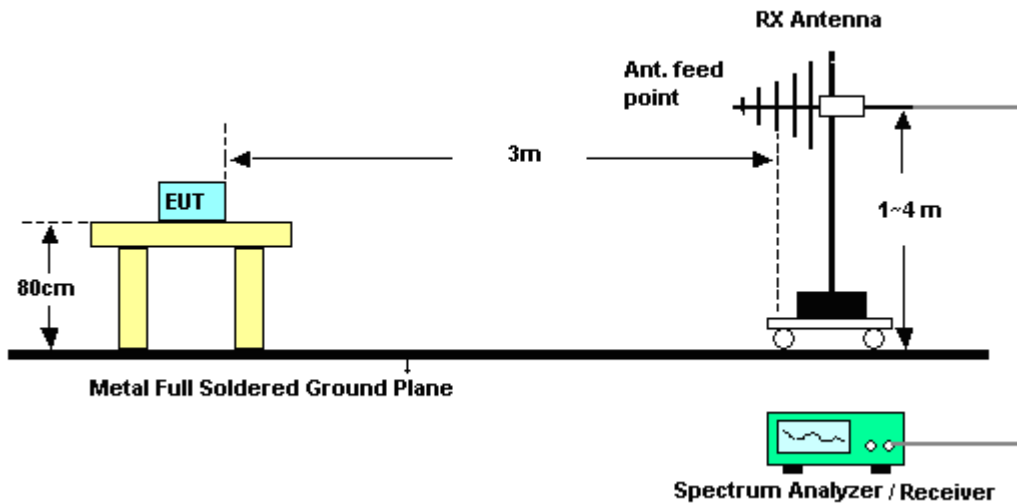

For radiated emissions above 1GHz

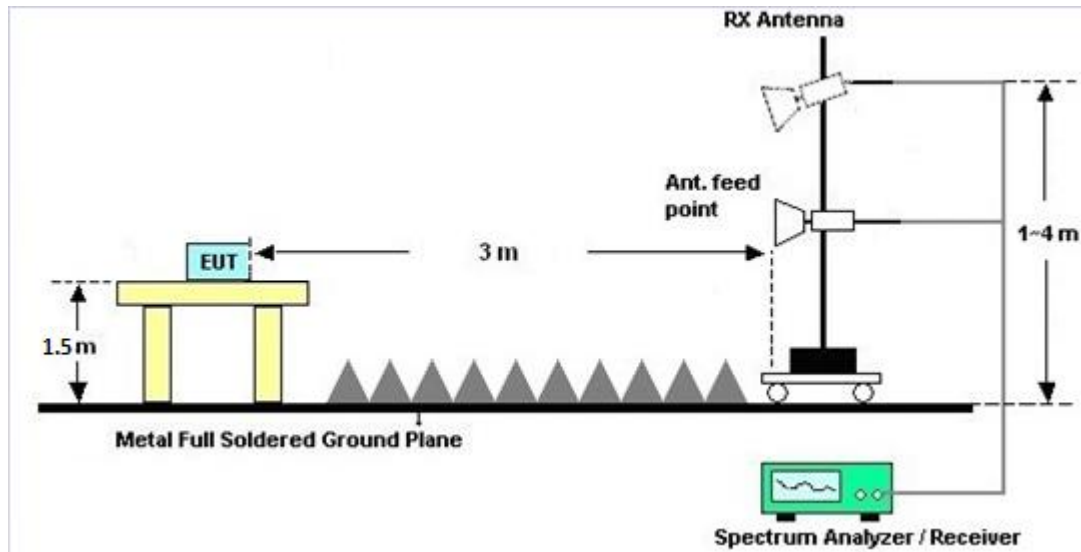

3.5.5 Test Results of Radiated Spurious Emissions (9 kHz ~ 30 MHz)

The low frequency, which started from 9 kHz to 30MHz, was pre-scanned and the result which was 20dB lower than the limit line was not reported.

There is a comparison data of both open-field test site and semi-Anechoic chamber, and the result came out very similar.

3.5.6 Test Result of Conducted Spurious at Band Edges in the Restricted Band

Please refer to Appendix B and C.

3.5.7 Test Result of Conducted Spurious Emission in the Restricted Band

Please refer to Appendix B and C.

3.5.8 Test Result of Cabinet Radiated Spurious Emission (30MHz ~ 10th Harmonic)

Please refer to Appendix D and E.

3.5.9 Duty Cycle

Please refer to Appendix F.



3.6 AC Conducted Emission Measurement

3.6.1 Limit of AC Conducted Emission

For equipment that is designed to be connected to the public utility (AC) power line, the radio frequency voltage that is conducted back onto the AC power line on any frequency or frequencies within the band 150 kHz to 30 MHz shall not exceed the limits in the following table.

Frequency of emission (MHz)	Conducted limit (dB μ V)	
	Quasi-peak	Average
0.15-0.5	66 to 56*	56 to 46*
0.5-5	56	46
5-30	60	50

*Decreases with the logarithm of the frequency.

3.6.2 Measuring Instruments

The section 4.0 of List of Measuring Equipment of this test report is used for test.

3.6.3 Test Procedures

1. The EUT was placed 0.4 meter from the conducting wall of the shielding room was kept at least 80 centimeters from any other grounded conducting surface.
2. Connect EUT to the power mains through a line impedance stabilization network (LISN).
3. All the support units are connecting to the other LISN.
4. The LISN provides 50 ohm coupling impedance for the measuring instrument.
5. The FCC states that a 50 ohm, 50 microhenry LISN should be used.
6. Both sides of AC line were checked for maximum conducted interference.
7. The frequency range from 150 kHz to 30 MHz was searched.
8. Set the test-receiver system to Peak Detect Function and specified bandwidth (IF Bandwidth = 9kHz) with Maximum Hold Mode. Then measurement is also conducted by Average Detector and Quasi-Peak Detector Function respectively.

3.6.4 Test Setup

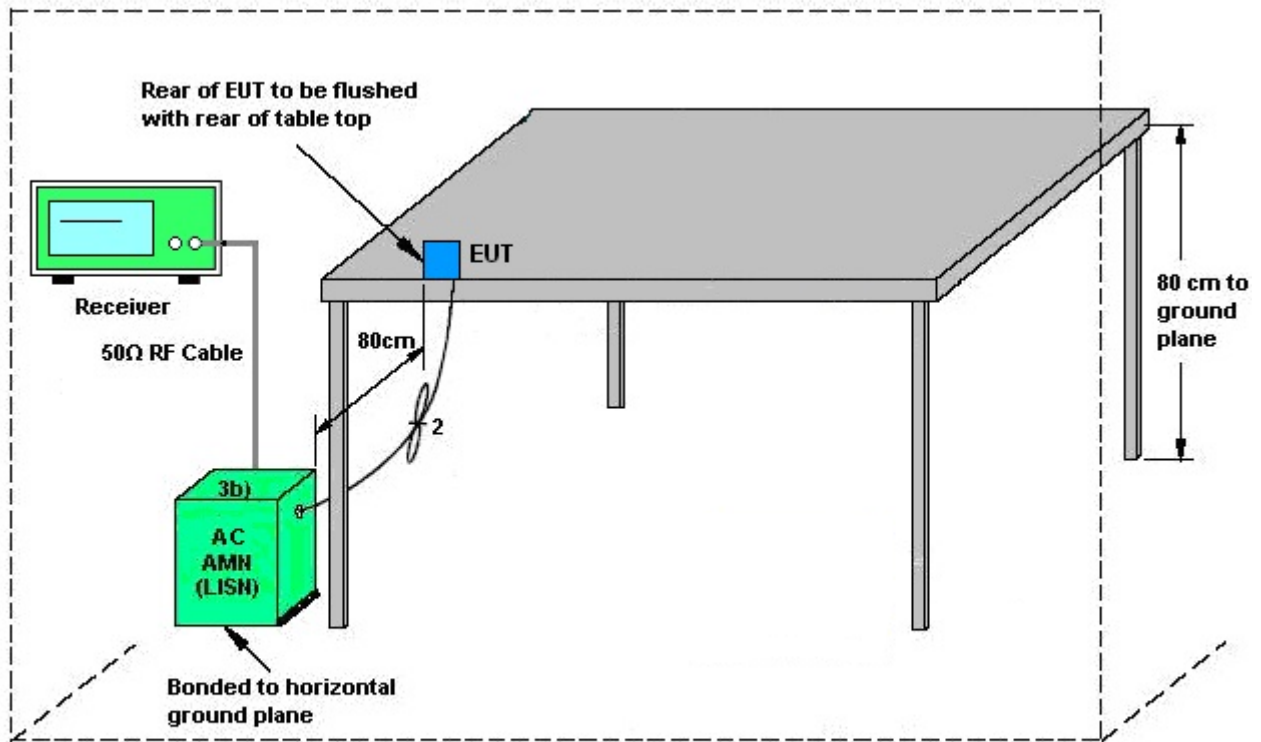

AMN = Artificial mains network (LISH)
AE = Associated equipment
EUT = Equipment under test
ISN = Impedance stabilization network



3.6.5 Test Result of AC Conducted Emission

Test Mode :	Mode 2	Temperature :	26~27°C
Test Engineer :	Kai-Chun Chu	Relative Humidity :	54~55%
Test Voltage :	120Vac / 60Hz	Phase :	Line
Function Type :	WLAN Tx + 15.4 Tx + Speaker on + LED on + RR LED on + IR CUT on + Memory + Camera on + USB Cable (Charging from Adapter 1)		

ENV216 Auto Test FCC Power Bar - L

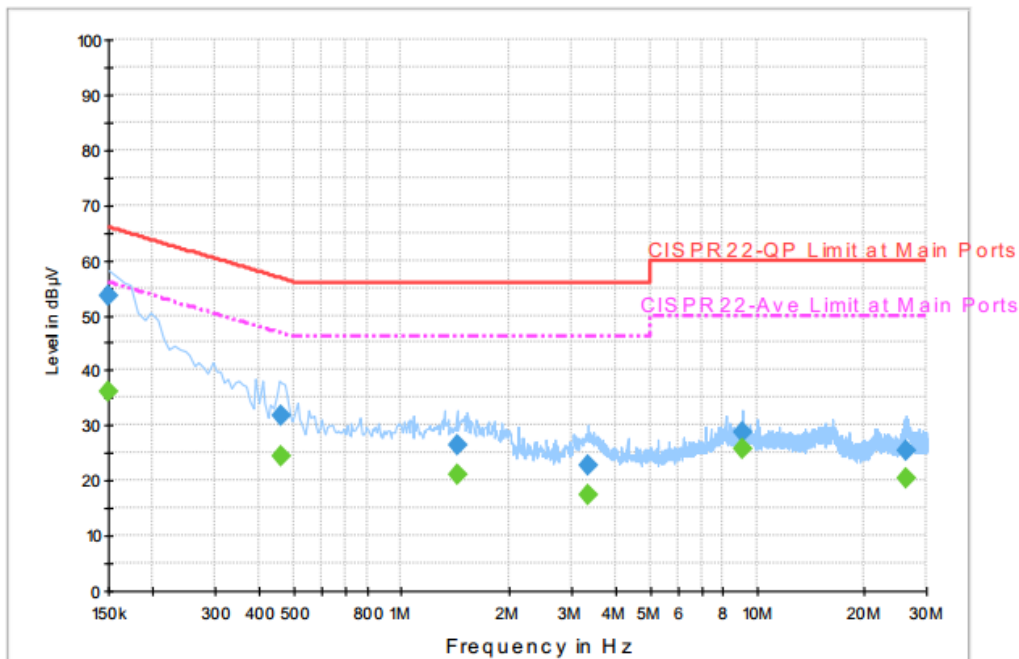

Final Result : QuasiPeak

Frequency (MHz)	QuasiPeak (dBµV)	Filter	Line	Corr. (dB)	Margin (dB)	Limit (dBµV)
0.150000	53.5	Off	L1	19.6	12.5	66.0
0.462000	31.8	Off	L1	19.6	24.9	56.7
1.438000	26.3	Off	L1	19.6	29.7	56.0
3.350000	22.6	Off	L1	19.6	33.4	56.0
9.110000	28.6	Off	L1	20.0	31.4	60.0
26.254000	25.4	Off	L1	20.9	34.6	60.0

Final Result : Average

Frequency (MHz)	Average (dBµV)	Filter	Line	Corr. (dB)	Margin (dB)	Limit (dBµV)
0.150000	36.2	Off	L1	19.6	19.8	56.0
0.462000	24.5	Off	L1	19.6	22.2	46.7
1.438000	21.1	Off	L1	19.6	24.9	46.0
3.350000	17.4	Off	L1	19.6	28.6	46.0
9.110000	25.7	Off	L1	20.0	24.3	50.0
26.254000	20.5	Off	L1	20.9	29.5	50.0



Test Mode :	Mode 2	Temperature :	26~27°C
Test Engineer :	Kai-Chun Chu	Relative Humidity :	54~55%
Test Voltage :	120Vac / 60Hz	Phase :	Neutral
Function Type :	WLAN Tx + 15.4 Tx + Speaker on + LED on + RR LED on + IR CUT on + Memory + Camera on + USB Cable (Charging from Adapter 1)		

ENV216 Auto Test FCC Power Bar - N

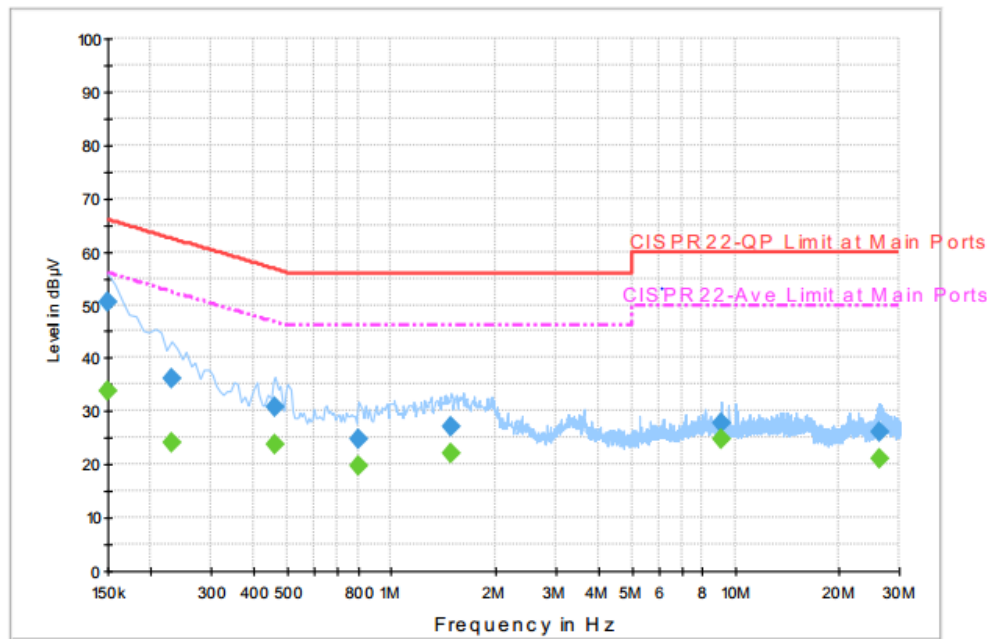

Final Result : QuasiPeak

Frequency (MHz)	QuasiPeak (dBµV)	Filter	Line	Corr. (dB)	Margin (dB)	Limit (dBµV)
0.150000	50.6	Off	N	19.5	15.4	66.0
0.230000	36.3	Off	N	19.5	26.1	62.4
0.462000	30.9	Off	N	19.5	25.8	56.7
0.806000	24.8	Off	N	19.6	31.2	56.0
1.486000	27.2	Off	N	19.6	28.8	56.0
9.110000	27.7	Off	N	20.0	32.3	60.0
26.302000	26.0	Off	N	21.0	34.0	60.0

Final Result : Average

Frequency (MHz)	Average (dBµV)	Filter	Line	Corr. (dB)	Margin (dB)	Limit (dBµV)
0.150000	33.9	Off	N	19.5	22.1	56.0
0.230000	24.2	Off	N	19.5	28.2	52.4
0.462000	23.6	Off	N	19.5	23.1	46.7
0.806000	19.9	Off	N	19.6	26.1	46.0
1.486000	22.1	Off	N	19.6	23.9	46.0
9.110000	24.8	Off	N	20.0	25.2	50.0
26.302000	21.0	Off	N	21.0	29.0	50.0



3.7 Antenna Requirements

3.7.1 Standard Applicable

If directional gain of transmitting antennas is greater than 6dBi, the power shall be reduced by the same level in dB comparing to gain minus 6dBi. The use of a permanently attached antenna or of an antenna that uses a unique coupling to the intentional radiator shall be considered sufficient to comply with the rule.

3.7.2 Antenna Anti-Replacement Construction

An embedded-in antenna design is used.

3.7.3 Antenna Gain

The antenna peak gain of EUT is less than 6 dBi. Therefore, it is not necessary to reduce maximum peak output power limit.



4 List of Measuring Equipment

Instrument	Manufacturer	Model No.	Serial No.	Characteristics	Calibration Date	Test Date	Due Date	Remark
Power Meter	Agilent	E4416A	GB412923 44	NA	Dec. 26, 2016	Jul. 09, 2017 ~ Jul. 21, 2017	Dec. 25, 2017	Conducted (TH05-HY)
Power Sensor	Agilent	E9327A	US404415 48	50MHz~18GHz	Dec. 26, 2016	Jul. 09, 2017 ~ Jul. 21, 2017	Dec. 25, 2017	Conducted (TH05-HY)
Spectrum Analyzer	Rohde & Schwarz	FSP40	100057	9kHz-40GHz	Nov. 25, 2016	Jul. 09, 2017 ~ Jul. 21, 2017	Nov. 24, 2017	Conducted (TH05-HY)
AC Power Source	ChainTek	APC-1000W	N/A	N/A	N/A	Sep. 07, 2017	N/A	Conduction (CO05-HY)
LISN	Rohde & Schwarz	ENV216	100080	9kHz~30MHz	Nov. 29, 2016	Sep. 07, 2017	Nov. 28, 2017	Conduction (CO05-HY)
EMI Test Receiver	Rohde & Schwarz	ESU26	100472	20Hz~26.5GHz	Dec. 29, 2016	Sep. 07, 2017	Dec. 28, 2017	Conduction (CO05-HY)
Spectrum Analyzer	Keysight	N9010A	MY542004 86	10Hz ~ 44GHz	Oct. 12, 2016	Jul. 14, 2017 ~ Jul. 25, 2017	Oct. 11, 2017	Radiation (03CH11-HY)
EMI Test Receiver	Agilent	N9038A (MXE)	MY532900 53	20Hz to 26.5GHz	Jan. 12, 2017	Jul. 14, 2017 ~ Jul. 25, 2017	Jan. 11, 2018	Radiation (03CH11-HY)
Loop Antenna	Rohde & Schwarz	HFH2-Z2	100488	9 kHz~30 MHz	Oct. 20, 2016	Jul. 14, 2017 ~ Jul. 25, 2017	Oct. 19, 2018	Radiation (03CH11-HY)
Bilog Antenna	TESEQ	CBL 6111D&N-6-0 6	35414&AT- N0602	30MHz~1GHz	Oct. 15, 2016	Jul. 14, 2017 ~ Jul. 25, 2017	Oct. 14, 2017	Radiation (03CH11-HY)
Horn Antenna	SCHWARZBE CK	BBHA 9120 D	9120D-132 6	1GHz ~ 18GHz	Oct. 07, 2016	Jul. 14, 2017 ~ Jul. 25, 2017	Oct. 06, 2017	Radiation (03CH11-HY)
SHF-EHF Horn Antenna	SCHWARZBE CK	BBHA 9170	BBHA9170 584	18GHz- 40GHz	Nov. 08, 2016	Jul. 14, 2017 ~ Jul. 25, 2017	Nov. 07, 2017	Radiation (03CH11-HY)
Amplifier	SONOMA	310N	187312	9kHz~1GHz	Nov. 10, 2016	Jul. 14, 2017 ~ Jul. 25, 2017	Nov. 09, 2017	Radiation (03CH11-HY)
Preamplifier	Keysight	83017A	MY532700 80	1GHz~26.5GHz	Nov. 10, 2016	Jul. 14, 2017 ~ Jul. 25, 2017	Nov. 09, 2017	Radiation (03CH11-HY)
Preamplifier	MITEQ	AMF-7D-0010 1800-30-10P	1902247	1GHz~18GHz	Jun. 23, 2017	Jul. 14, 2017 ~ Jul. 25, 2017	Jun. 22, 2018	Radiation (03CH11-HY)
Preamplifier	MITEQ	TTA1840-35- HG	1887435	18GHz~40GHz	Oct. 13, 2016	Jul. 14, 2017 ~ Jul. 25, 2017	Oct. 12, 2017	Radiation (03CH11-HY)
Antenna Mast	EMEC	AM-BS-4500- B	N/A	1~4m	N/A	Jul. 14, 2017 ~ Jul. 25, 2017	N/A	Radiation (03CH11-HY)
Turn Table	EMEC	TT 2000	N/A	0~360 Degree	N/A	Jul. 14, 2017 ~ Jul. 25, 2017	N/A	Radiation (03CH11-HY)
Spectrum Analyzer	Agilent	N9010A	MY534701 18	10Hz~44GHz	Apr. 17, 2017	Jul. 13, 2017	Apr. 16, 2018	CSE (03CH15-HY)
EMI Test Receiver	Keysight	N9038A (MXE)	MY541300 85	20Hz ~ 8.4GHz	Oct. 26, 2016	Jul. 13, 2017	Oct. 25, 2017	CSE (03CH15-HY)



5 Uncertainty of Evaluation

Uncertainty of Conducted Emission Measurement (150 kHz ~ 30 MHz)

Measuring Uncertainty for a Level of Confidence of 95% ($U = 2Uc(y)$)	2.70
-------------------------------------------------------------------------	------

Uncertainty of Radiated Emission Measurement (30 MHz ~ 1000 MHz)

Measuring Uncertainty for a Level of Confidence of 95% ($U = 2Uc(y)$)	5.20
-------------------------------------------------------------------------	------

Uncertainty of Radiated Emission Measurement (1000 MHz ~ 18000 MHz)

Measuring Uncertainty for a Level of Confidence of 95% ($U = 2Uc(y)$)	5.50
-------------------------------------------------------------------------	------

Uncertainty of Radiated Emission Measurement (18000 MHz ~ 40000 MHz)

Measuring Uncertainty for a Level of Confidence of 95% ($U = 2Uc(y)$)	5.20
-------------------------------------------------------------------------	------

Appendix A. Test Result of Conducted Test Items

Test Engineer:	Aking chnag	Temperature:	21~25	°C
Test Date:	2017/7/9~2017/7/21	Relative Humidity:	51~54	%

TEST RESULTS DATA
6dB and 99% Occupied Bandwidth

Mod.	Data Rate	Ntx	CH.	Freq. (MHz)	99% Occupied BW (MHz)	6dB BW (MHz)	6dB BW Limit (MHz)	Pass/Fail
15.4	250kbps	1	11	2405	2.365	1.195	0.50	Pass
15.4	250kbps	1	18	2440	2.325	1.205	0.50	Pass
15.4	250kbps	1	25	2475	2.370	1.579	0.50	Pass

TEST RESULTS DATA
Peak Power Table

Mod.	Data Rate	Ntx	CH.	Freq. (MHz)	Peak Conducted Power (dBm)	Conducted Power Limit (dBm)	DG (dBi)	EIRP Power (dBm)	EIRP Power Limit (dBm)	Pass /Fail
15.4	250kbps	1	11	2405	20.27	30.00	3.37	23.64	36.00	Pass
15.4	250kbps	1	18	2440	20.73	30.00	3.37	24.10	36.00	Pass
15.4	250kbps	1	25	2475	9.96	30.00	3.37	13.33	36.00	Pass

TEST RESULTS DATA
Average Power Table
(Reporting Only)

Mod.	Data Rate	Ntx	CH.	Freq. (MHz)	Duty Factor (dB)	Average Conducted Power (dBm)
15.4	250kbps	1	11	2405	8.86	19.90
15.4	250kbps	1	18	2440	8.86	20.40
15.4	250kbps	1	25	2475	8.86	8.60

TEST RESULTS DATA
Peak Power Density

Mod.	Data Rate	Ntx	CH.	Freq. (MHz)	Peak PSD (dBm /100kHz)	Peak PSD (dBm /3kHz)	DG (dBi)	Peak PSD Limit (dBm /3kHz)	Pass/Fail
15.4	250kbps	1	11	2405	19.17	6.34	3.37	8.00	Pass
15.4	250kbps	1	18	2440	19.86	7.54	3.37	8.00	Pass
15.4	250kbps	1	25	2475	5.24	-4.32	3.37	8.00	Pass

Note: PSD (dBm/ 100kHz) is a reference level used for Conducted Band Edges and Conducted Spurious Emission 20dBc limit.



Appendix B. Conducted Spurious Emission

Test Engineer :	Aking Chang	Temperature :	21~25°C
		Relative Humidity :	51~54%

2.4GHz 2400~2483.5MHz

15.4 (Band Edge @ Conducted)

15.4	Note	Frequency	Level	Over Limit	Limit Line	Read Level	Antenna Factor	Cable Loss	Aux Factor	Aux2 Factor	Peak Avg.
		(MHz)	(dBm)	(dB)	(dBm)	(dBm)	(dBi)	(dB)	(dB)	(dB)	(P/A)
15.4 CH 11 2405MHz		2389.275	-29.51	-8.31	-21.2	-35.76	3.37	2.06	0.82	-	P
		2390	-41.76	-0.56	-41.2	-48.67	3.37	2.06	0.82	-	A
	*	2405	23.29	-	-	17.04	3.37	2.06	0.82	-	P
	*	2405	21.34	-	-	15.09	3.37	2.06	0.82	-	A
15.4 CH 18 2440MHz		2388.54	-30.56	-9.36	-21.2	-36.8	3.36	2.06	0.82	-	P
		2386.86	-51.35	-10.15	-41.2	-57.59	3.36	2.06	0.82	-	A
	*	2440	25.41	-	-	19.13	3.36	2.08	0.84	-	P
	*	2440	23.52	-	-	17.24	3.36	2.08	0.84	-	A
		2485.93	-28.49	-7.29	-21.2	-34.81	3.36	2.1	0.86	-	P
		2486.21	-49.39	-8.19	-41.2	-55.71	3.36	2.1	0.86	-	A
15.4 CH 25 2475MHz	*	2475	11.81	-	-	6.03	2.83	2.1	0.85	-	P
	*	2475	9.99	-	-	4.21	2.83	2.1	0.85	-	A
		2483.62	-35.03	-13.83	-21.2	-40.81	2.83	2.1	0.85	-	P
		2483.52	-42.42	-1.22	-41.2	-48.2	2.83	2.1	0.85	-	A
Remark	1. No other spurious found. 2. All results are PASS against Peak and Average limit line.										



2.4GHz 2400~2483.5MHz
15.4 (Harmonic @ Conducted)

15.4	Note	Frequency (MHz)	Level (dBm)	Over Limit (dB)	Limit Line (dBm)	Read Level (dBm)	Antenna Factor (dBi)	Cable Loss (dB)	Aux Factor (dB)	Aux2 Factor (dB)	Peak Avg. (P/A)
15.4 CH 11 2405MHz		4810	-70.95	-49.75	-21.2	-79.19	3.37	3.05	1.82	-	P
15.4 CH 18 2440MHz		4880	-66.48	-45.28	-21.2	-74.73	3.37	3.07	1.81	-	P
		7320	-70.64	-49.44	-21.2	-80.39	3.37	4.01	2.37	-	P
15.4 CH 25 2475MHz		4950	-72.89	-51.69	-21.2	-80.62	2.83	3.1	1.8	-	P
		7425	-72.31	-51.11	-21.2	-81.6	2.83	4.07	2.39	-	P
Remark	1. No other spurious found. 2. All results are PASS against Peak and Average limit line.										



Emission below 1GHz

2.4GHz 15.4 (LF)

15.4	Note	Frequency	Level	Over Limit	Limit Line	Read Level	Antenna Factor	Cable Loss	Aux Factor	Aux2 Factor	Peak Avg.
		(MHz)	(dBm)	(dB)	(dBm)	(dBm)	(dBi)	(dB)	(dB)	(dB)	(P/A)
2.4GHz 15.4 LF		35.94	-83.13	-27.93	-55.2	-91.53	3.37	0.24	0.09	4.7	P
		108.57	-83.73	-32.03	-51.7	-92.43	3.37	0.41	0.22	4.7	P
		250.86	-83.55	-34.35	-49.2	-92.58	3.37	0.58	0.38	4.7	P
		480.6	-78.43	-29.23	-49.2	-87.74	3.37	0.81	0.43	4.7	P
		600.3	-76.26	-27.06	-49.2	-85.78	3.37	0.94	0.51	4.7	P
		934.9	-70.2	-21	-49.2	-80.22	3.37	1.22	0.73	4.7	P
Remark	1. No other spurious found. 2. All results are PASS against limit line.										



Note symbol

*	Fundamental Frequency which can be ignored. However, the level of any unwanted emissions shall not exceed the level of the fundamental frequency.
!	Test result is over limit line.
P/A	Peak or Average
H/V	Horizontal or Vertical



A calculation example for conducted spurious emission is shown as below:

WIFI	Note	Frequency	Level	Over	Limit	Read	Antenna	Cable	Aux	Aux2	Peak
Ant.				Limit	Line	Level	Factor	Loss	Factor	Factor	Avg.
1		(MHz)	(dBm)	(dB)	(dBm)	(dBm)	(dBi)	(dB)	(dB)	(dB)	(P/A)
802.11b		2390	-29.51	-8.31	-21.2	-35.76	3.37	2.06	0.82	0	P
CH 01											
2412MHz		2390	-41.76	-0.56	-41.2	-48.01	3.37	2.06	0.82	0	A

1. Level(dBm) =

$$\text{Aux Factor(dB)} + \text{Aux2 Factor(dB)} + \text{Antenna Factor(dBi)} + \text{Cable Loss(dB)} + \text{Read Level(dBm)}$$

2. Over Limit(dB) = Level(dBm) – Limit Line(dBm)

For Peak Limit @ 2390MHz:

1. Level(dBm)

$$= \text{Aux Factor(dB)} + \text{Aux2 Factor(dB)} + \text{Antenna Factor(dBi)} + \text{Cable Loss(dB)} + \text{Read Level(dBm)}$$

$$= 0.82(\text{dB}) + 0(\text{dB}) + 3.37(\text{dBi}) + 2.06(\text{dB}) + -35.76(\text{dBm})$$

$$= -29.51(\text{dBm})$$

2. Over Limit(dB)

$$= \text{Level(dBm)} - \text{Limit Line(dBm)}$$

$$= -29.51(\text{dBm}) - [-21.2(\text{dBm})]$$

$$= -8.31(\text{dB})$$

For Average Limit @ 2390MHz:

1. Level(dBm)

$$= \text{Aux Factor(dB)} + \text{Aux2 Factor(dB)} + \text{Antenna Factor(dBi)} + \text{Cable Loss(dB)} + \text{Read Level(dBm)}$$

$$= 0.82(\text{dB}) + 0(\text{dB}) + 3.37(\text{dBi}) + 2.06(\text{dB}) + -48.01(\text{dBm})$$

$$= -41.76(\text{dBm})$$

2. Over Limit(dB)

$$= \text{Level(dBm)} - \text{Limit Line(dBm)}$$

$$= -41.76(\text{dBm}) - [-41.2(\text{dBm})]$$

$$= -0.56(\text{dB})$$

Both peak and average measured complies with the limit line, so test result is “PASS”.



Appendix C. Conducted Spurious Emission Plots

Test Engineer :	Aking Chang	Temperature :	21~25°C
		Relative Humidity :	51~54%

Note symbol

-L	Low channel location
-R	High channel location



2.4GHz 2400~2483.5MHz

15.4 (Band Edge @ Conducted)

15.4	2.4GHz 2400~2483.5MHz Band Edge @ Conducted	
	15.4 CH11 2405MHz	
	Band Edge - L	Fundamental
Peak	<p>Site : 03CH15-HY Condition : FCC CLASS-B_CON ANT_GAIN+3.37 HORIZONTAL</p>	<p>Site : 03CH15-HY Condition : FCC CLASS-B_CON ANT_GAIN+3.37 HORIZONTAL</p>
Avg.	<p>Site : 03CH15-HY Condition : FCC CLASS-B(AVG)_CON ANT_GAIN+3.37 HORIZONTAL</p>	<p>Site : 03CH15-HY Condition : FCC CLASS-B(AVG)_CON ANT_GAIN+3.37 HORIZONTAL</p>



15.4	2.4GHz 2400~2483.5MHz Band Edge @ Conducted	
15.4 CH18 2440MHz		
	Band Edge - L	Fundamental
Peak	<p>Site Condition : 03CH15-HY FCC CLASS-B_CON ANT_GAIN+3.37 HORIZONTAL</p>	<p>Site Condition : 03CH15-HY FCC CLASS-B_CON ANT_GAIN+3.37 HORIZONTAL</p>
Avg.	<p>Site Condition : 03CH15-HY FCC CLASS-B(AVG)_CON ANT_GAIN+3.37 HORIZONTAL</p>	<p>Site Condition : 03CH15-HY FCC CLASS-B(AVG)_CON ANT_GAIN+3.37 HORIZONTAL</p>

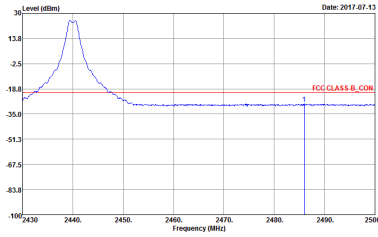
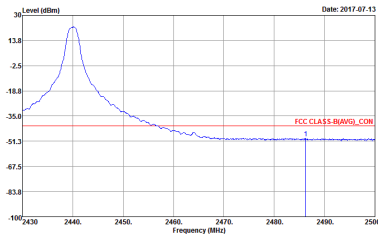

15.4	2.4GHz 2400~2483.5MHz Band Edge @ Conducted	
15.4 CH18 2440MHz		
	Band Edge - R	Fundamental
Peak	 <p>Site : 03CH15-HY Condition : FCC CLASS-B_CON ANT_GAIN+3.37 HORIZONTAL</p>	Blank
Avg.	 <p>Site : 03CH15-HY Condition : FCC CLASS-B(AVG)_CON ANT_GAIN+3.37 HORIZONTAL</p>	Blank

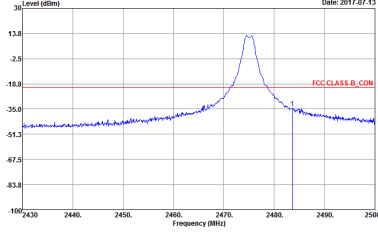
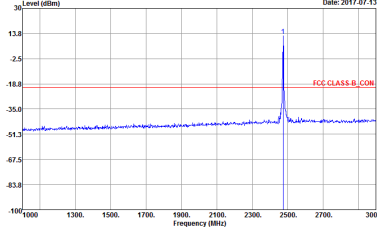
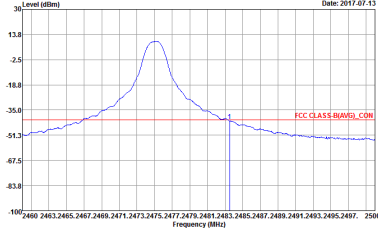
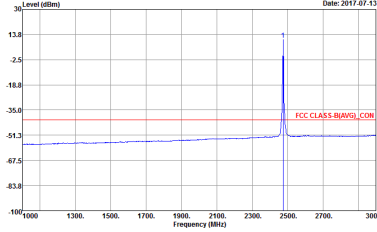

15.4	2.4GHz 2400~2483.5MHz Band Edge @ Conducted	
15.4 CH25 2475MHz		
	Band Edge - R	Fundamental
Peak	 <p>Site Condition : 03CH15-HY : FCC CLASS-B_CON_ANT_GAIN+3.37 HORIZONTAL</p>	 <p>Site Condition : 03CH15-HY : FCC CLASS-B_CON_ANT_GAIN+3.37 HORIZONTAL</p>
Avg.	 <p>Site Condition : 03CH15-HY : FCC CLASS-B(AVG)_CON_ANT_GAIN+3.37 HORIZONTAL</p>	 <p>Site Condition : 03CH15-HY : FCC CLASS-B(AVG)_CON_ANT_GAIN+3.37 HORIZONTAL</p>



2.4GHz 2400~2483.5MHz

15.4 (Harmonic @ Conducted)

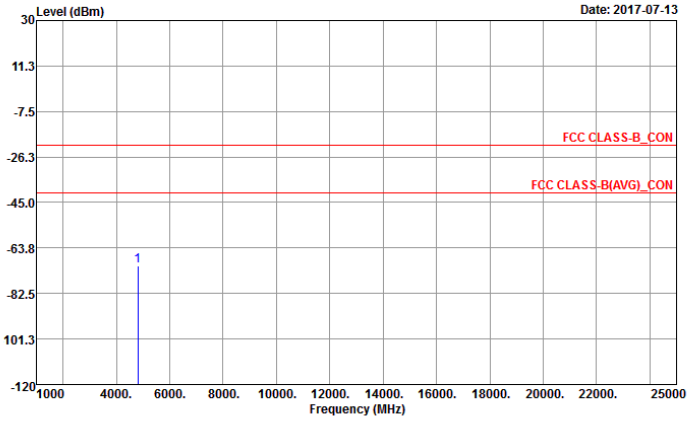
15.4	2.4GHz 2400~2483.5MHz Harmonic @ Conducted
	15.4 CH11 2405MHz
Peak Avg.	 <p>Date: 2017-07-13</p> <p>Site : 03CH15-HY Condition : FCC CLASS-B CON ANT GAIN+3.37 HORIZONTAL</p>

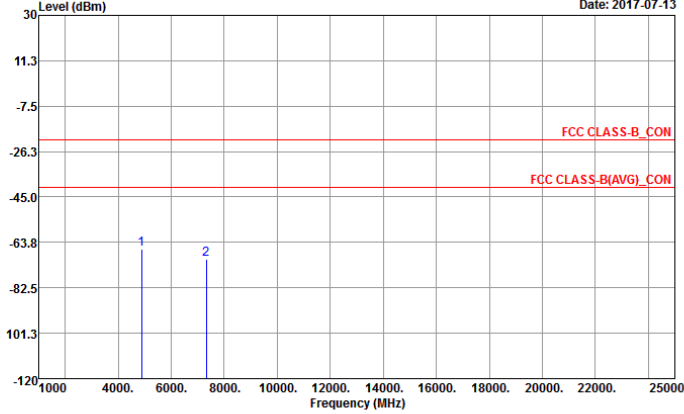

15.4	2.4GHz 2400~2483.5MHz Harmonic @ Conducted
	15.4 CH18 2440MHz
Peak Avg.	 <p>Date: 2017-07-13</p> <p>Site : 03CH15-HY Condition : FCC CLASS-B_CON ANT_GAIN+3.37 HORIZONTAL</p>

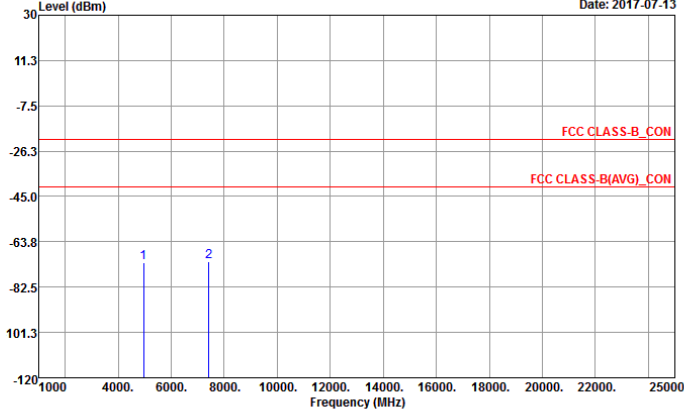

15.4	2.4GHz 2400~2483.5MHz Harmonic @ Conducted
	15.4 CH25 2475MHz
Peak	 <p>Date: 2017-07-13</p> <p>Site : 03CH15-HY Condition : FCC CLASS-B_CON ANT_GAIN+3.37 HORIZONTAL</p>



Emission below 1GHz

2.4GHz 15.4 (LF)

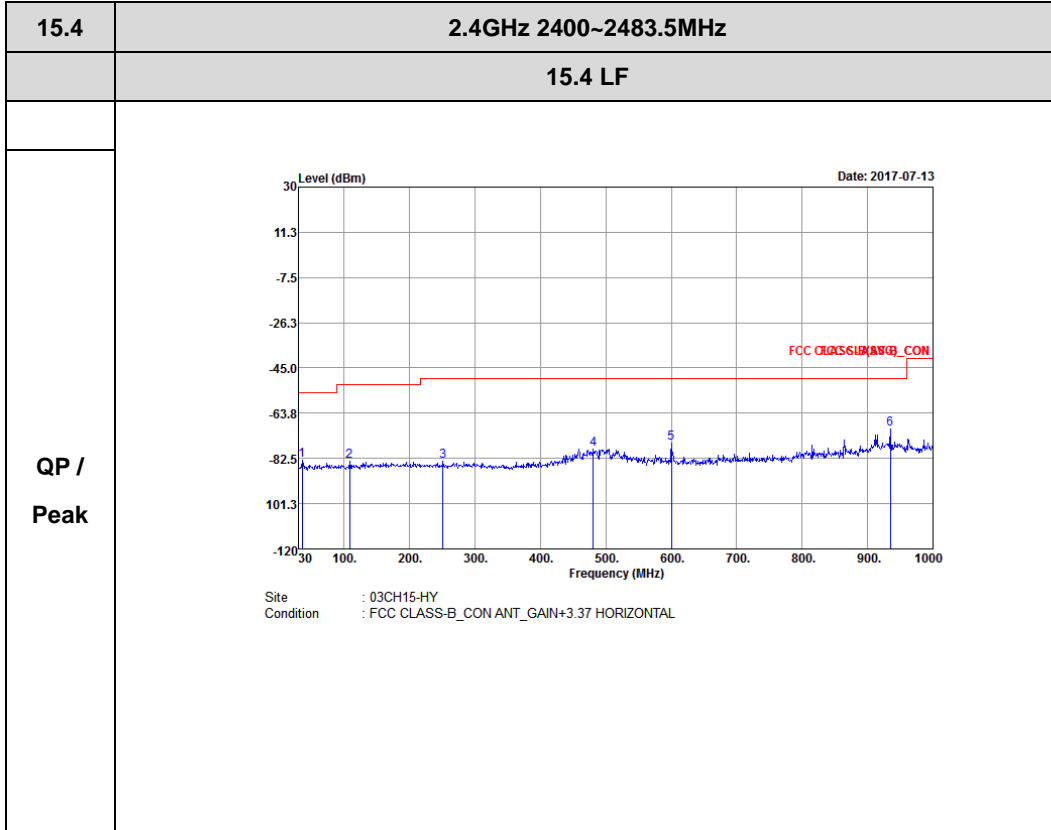



Appendix D. Cabinet Radiation data

Test Engineer :	J.C. Liang, Jacky Huang, Ken Wu	Temperature :	20~24°C
		Relative Humidity :	50~54%

2.4GHz 2400~2483.5MHz

15.4 (Band Edge @ 3m)

15.4	Note	Frequency	Level	Over Limit	Limit Line	Read Level	Antenna Factor	Cable Loss	Preamp Factor	Ant Pos	Table Pos	Peak Avg.	Pol.
		(MHz)	(dBμV/m)	(dB)	(dBμV/m)	(dBμV)	(dB/m)	(dB)	(dB)	(cm)	(deg)	(P/A)	(H/V)
15.4 CH 11 2405MHz		2318.715	51.76	-22.24	74	42.64	26.65	6.15	33.61	117	332	P	H
		2375.205	41.91	-12.09	54	32.48	26.81	6.29	33.6	117	332	A	H
	*	2405	91.6	-	-	81.98	26.92	6.36	33.59	117	332	P	H
	*	2405	89.61	-	-	79.99	26.92	6.36	33.59	117	332	A	H
		2363.76	51.68	-22.32	74	42.3	26.76	6.29	33.6	314	286	P	V
		2390	41.88	-12.12	54	32.31	26.87	6.36	33.59	314	286	A	V
	*	2405	90.73	-	-	81.11	26.92	6.36	33.59	314	286	P	V
	*	2405	88.91	-	-	79.29	26.92	6.36	33.59	314	286	A	V
15.4 CH 18 2440MHz		2371.04	52.31	-21.69	74	42.88	26.81	6.29	33.6	100	330	P	H
		2385.04	41.73	-12.27	54	32.23	26.81	6.36	33.6	100	330	A	H
	*	2440	93.74	-	-	83.99	27.03	6.38	33.59	100	330	P	H
	*	2440	91.93	-	-	82.18	27.03	6.38	33.59	100	330	A	H
		2496.71	52.81	-21.19	74	42.86	27.2	6.39	33.57	100	330	P	H
		2492.44	42.18	-11.82	54	32.23	27.2	6.39	33.57	100	330	A	H
		2349.2	52	-22	74	42.75	26.7	6.22	33.6	278	286	P	V
		2381.96	41.74	-12.26	54	32.24	26.81	6.36	33.6	278	286	A	V
	*	2440	94.61	-	-	84.86	27.03	6.38	33.59	278	286	P	V
	*	2440	92.58	-	-	82.83	27.03	6.38	33.59	278	286	A	V
		2487.33	51.89	-22.11	74	42.01	27.14	6.39	33.58	278	286	P	V
		2494.61	42.15	-11.85	54	32.2	27.2	6.39	33.57	278	286	A	V



15.4 CH 25 2475MHz	*	2475	80.79	-	-	70.92	27.14	6.38	33.58	108	330	P	H
	*	2475	79.02	-	-	69.15	27.14	6.38	33.58	108	330	A	H
		2492.44	52.41	-21.59	74	42.46	27.2	6.39	33.57	108	330	P	H
		2490.36	42.18	-11.82	54	32.24	27.2	6.39	33.58	108	330	A	H
	*	2475	80.54	-	-	70.67	27.14	6.38	33.58	313	284	P	V
	*	2475	78.68	-	-	68.81	27.14	6.38	33.58	313	284	A	V
		2486.6	52.36	-21.64	74	42.48	27.14	6.39	33.58	313	284	P	V
		2486.16	42.24	-11.76	54	32.36	27.14	6.39	33.58	313	284	A	V
Remark	1. No other spurious found. 2. All results are PASS against Peak and Average limit line.												



2.4GHz 2400~2483.5MHz
15.4 (Harmonic @ 3m)

15.4	Note	Frequency (MHz)	Level (dBμV/m)	Over Limit (dB)	Limit Line (dBμV/m)	Read Level (dBμV)	Antenna Factor (dB/m)	Cable Loss (dB)	Preamp Factor (dB)	Ant Pos (cm)	Table Pos (deg)	Peak Avg. (P/A)	Pol. (H/V)
15.4 CH 11 2405MHz		4810	52.81	-21.19	74	74.2	31.6	9.6	63.02	100	182	P	H
		4810	47.79	-6.21	54	69.18	31.6	9.6	63.02	100	182	A	H
		4810	54.32	-19.68	74	76.14	31.6	9.6	63.02	100	336	P	V
		4810	50.13	-3.87	54	71.95	31.6	9.6	63.02	100	336	A	V
15.4 CH 18 2440MHz		4880	55.26	-18.74	74	76.43	31.71	9.56	62.87	100	179	P	H
		4880	50.19	-3.81	54	71.36	31.71	9.56	62.87	100	179	A	H
		7320	59.47	-14.53	74	72.89	37.51	11.31	62.7	200	300	P	H
		7320	53.66	-0.34	54	67.08	37.51	11.31	62.7	200	300	A	H
		4880	56.61	-17.39	74	78.21	31.71	9.56	62.87	100	337	P	V
		4880	52.29	-1.71	54	73.89	31.71	9.56	62.87	100	337	A	V
		7320	58.08	-15.92	74	71.96	37.51	11.31	62.7	206	299	P	V
		7320	52.89	-1.11	54	66.77	37.51	11.31	62.7	206	299	A	V
15.4 CH 25 2475MHz		4950	43.66	-30.34	74	64.58	31.82	9.53	62.71	100	0	P	H
		7425	43.64	-30.36	74	56.71	37.98	11.34	62.76	100	0	P	H
		4950	46.89	-27.11	74	68.25	31.82	9.53	62.71	100	0	P	V
		7425	42.91	-31.09	74	56.35	37.98	11.34	62.76	100	0	P	V
Remark	1. No other spurious found. 2. All results are PASS against Peak and Average limit line.												



Emission below 1GHz

2.4GHz 15.4 (LF)

15.4	Note	Frequency	Level	Over	Limit	Read	Antenna	Cable	Preamp	Ant	Table	Peak	Pol.
		(MHz)	(dBμV/m)	(dB)	(dBμV/m)	(dBμV)	(dB/m)	(dB)	(dB)	(cm)	(deg)	(P/A)	(H/V)
2.4GHz 15.4 LF		147.45	24.38	-19.12	43.5	37.98	17.15	1.61	32.44			P	H
		194.7	25.61	-17.89	43.5	41.4	14.84	1.69	32.39			P	H
		249.51	31.4	-14.6	46	43.33	18.43	1.95	32.38			P	H
		859.3	31.72	-14.28	46	30.37	29.4	3.67	31.87			P	H
		929.3	33.54	-12.46	46	31	29.94	3.82	31.39			P	H
		949.6	34.19	-11.81	46	30.63	30.77	3.82	31.2	100	0	P	H
		37.83	30.35	-9.65	40	41.68	20.33	0.82	32.49	100	0	P	V
		60.78	26.18	-13.82	40	45.9	11.73	1.02	32.49			P	V
		70.5	24.6	-15.4	40	43.51	12.34	1.22	32.49			P	V
		795.6	30.82	-15.18	46	31.07	28.29	3.49	32.19			P	V
		846	32.16	-13.84	46	31.27	29.08	3.6	31.94			P	V
		951.7	33.51	-12.49	46	29.84	30.86	3.82	31.18			P	V
Remark	1. No other spurious found. 2. All results are PASS against limit line.												



Note symbol

*	Fundamental Frequency which can be ignored. However, the level of any unwanted emissions shall not exceed the level of the fundamental frequency.
!	Test result is over limit line.
P/A	Peak or Average
H/V	Horizontal or Vertical



A calculation example for radiated spurious emission is shown as below:

WIFI	Note	Frequency	Level	Over	Limit	Read	Antenna	Cable	Preamp	Ant	Table	Peak	Pol.
Ant.				Limit	Line	Level	Factor	Loss	Factor	Pos	Pos	Avg.	
1+2		(MHz)	(dBμV/m)	(dB)	(dBμV/m)	(dBμV)	(dB/m)	(dB)	(dB)	(cm)	(deg)	(P/A)	(H/V)
802.11b		2390	55.45	-18.55	74	54.51	32.22	4.58	35.86	103	308	P	H
CH 01													
2412MHz		2390	43.54	-10.46	54	42.6	32.22	4.58	35.86	103	308	A	H

- Level(dBμV/m) =
Antenna Factor(dB/m) + Cable Loss(dB) + Read Level(dBμV) - Preamp Factor(dB)
- Over Limit(dB) = Level(dBμV/m) – Limit Line(dBμV/m)

For Peak Limit @ 2390MHz:

- Level(dBμV/m)
= Antenna Factor(dB/m) + Cable Loss(dB) + Read Level(dBμV) - Preamp Factor(dB)
= 32.22(dB/m) + 4.58(dB) + 54.51(dBμV) – 35.86 (dB)
= 55.45 (dBμV/m)
- Over Limit(dB)
= Level(dBμV/m) – Limit Line(dBμV/m)
= 55.45(dBμV/m) – 74(dBμV/m)
= -18.55(dB)

For Average Limit @ 2390MHz:

- Level(dBμV/m)
= Antenna Factor(dB/m) + Cable Loss(dB) + Read Level(dBμV) - Preamp Factor(dB)
= 32.22(dB/m) + 4.58(dB) + 42.6(dBμV) – 35.86 (dB)
= 43.54 (dBμV/m)
- Over Limit(dB)
= Level(dBμV/m) – Limit Line(dBμV/m)
= 43.54(dBμV/m) – 54(dBμV/m)
= -10.46(dB)

Both peak and average measured complies with the limit line, so test result is “PASS”.



Appendix E. Cabinet Radiation Plots

Test Engineer :	J.C. Liang, Jacky Huang, Ken Wu	Temperature :	20~24°C
		Relative Humidity :	50~54%

Note symbol

-L	Low channel location
-R	High channel location



2.4GHz 2400~2483.5MHz

15.4 (Band Edge @ 3m)

15.4	2.4GHz 2400~2483.5MHz Band Edge @ 3m	
	15.4 Ch11 2405MHz	
	Horizontal	Fundamental
Peak	<p>Site : 03CH11-HY Condition : PEAK BE 74 3m HORN 91200-HF HORIZONTAL</p>	<p>Site : 03CH11-HY Condition : PEAK 74 3m HORN 91200-HF HORIZONTAL</p>
Avg.	<p>Site : 03CH11-HY Condition : AV6 BE 54 3m HORN 91200-HF HORIZONTAL</p>	<p>Site : 03CH11-HY Condition : AV6 54 3m HORN 91200-HF HORIZONTAL</p>



15.4	2.4GHz 2400~2483.5MHz Band Edge @ 3m	
	15.4 Ch11 2405MHz	
	Vertical	Fundamental
Peak	<p>Site : 03CH11-HY Condition : PEAK BE 74 3m HORN 91200-HF VERTICAL</p>	<p>Site : 03CH11-HY Condition : PEAK 74 3m HORN 91200-HF VERTICAL</p>
Avg	<p>Site : 03CH11-HY Condition : AVG BE 54 3m HORN 91200-HF VERTICAL</p>	<p>Site : 03CH11-HY Condition : AVG 54 3m HORN 91200-HF VERTICAL</p>

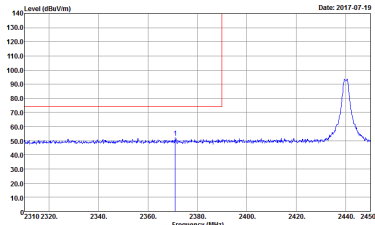
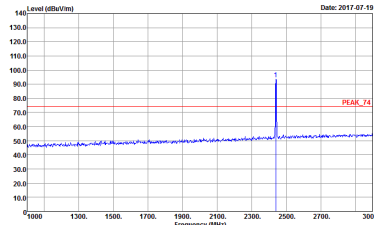
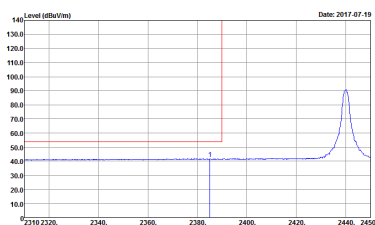
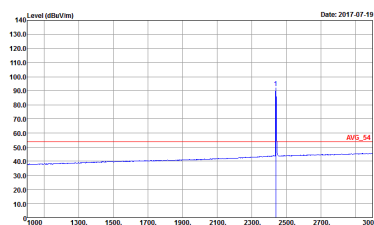

15.4	2.4GHz 2400~2483.5MHz Band Edge @ 3m	
15.4 CH18 2440MHz - L		
	Horizontal	Fundamental
Peak	 <p>Level (dBm/1m) vs Frequency (MHz) plot showing a peak at 2440 MHz. The y-axis ranges from 10.0 to 140.0 dBm/1m, and the x-axis ranges from 2310 to 2450 MHz. A red horizontal line is drawn at approximately 75 dBm/1m. The peak is labeled with a blue vertical line and the number '74'. The date is 2017-07-19.</p> <p>Site : 03CH11-HY Condition : PEAK BE 74 3m HORN 9120D-HF HORIZONTAL</p>	 <p>Level (dBm/1m) vs Frequency (MHz) plot showing a peak at 2440 MHz. The y-axis ranges from 10.0 to 140.0 dBm/1m, and the x-axis ranges from 1900 to 3000 MHz. A red horizontal line is drawn at approximately 75 dBm/1m. The peak is labeled with a blue vertical line and the number '74'. The date is 2017-07-19.</p> <p>Site : 03CH11-HY Condition : PEAK 74 3m HORN 9120D-HF HORIZONTAL</p>
Avg.	 <p>Level (dBm/1m) vs Frequency (MHz) plot showing an average spectrum. The y-axis ranges from 10.0 to 140.0 dBm/1m, and the x-axis ranges from 2310 to 2450 MHz. A red horizontal line is drawn at approximately 55 dBm/1m. The peak is labeled with a blue vertical line and the number '54'. The date is 2017-07-19.</p> <p>Site : 03CH11-HY Condition : AVG BE 54 3m HORN 9120D-HF HORIZONTAL</p>	 <p>Level (dBm/1m) vs Frequency (MHz) plot showing an average spectrum. The y-axis ranges from 10.0 to 140.0 dBm/1m, and the x-axis ranges from 1900 to 3000 MHz. A red horizontal line is drawn at approximately 55 dBm/1m. The peak is labeled with a blue vertical line and the number '54'. The date is 2017-07-19.</p> <p>Site : 03CH11-HY Condition : AVG 54 3m HORN 9120D-HF HORIZONTAL</p>

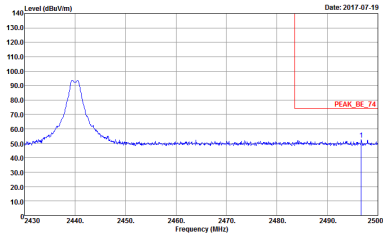
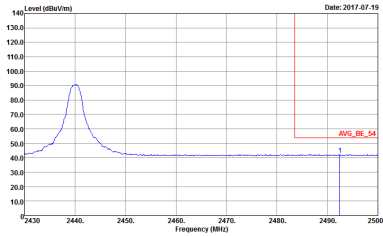

15.4	2.4GHz 2400~2483.5MHz Band Edge @ 3m	
15.4 CH18 2440MHz - R		
	Horizontal	Fundamental
<p>Peak</p>	 <p>Site : 03CH11-HY Condition : PEAK_BE_74 3m HORN 91200-HF HORIZONTAL</p>	<p>Left blank</p>
<p>Avg.</p>	 <p>Site : 03CH11-HY Condition : AVG_BE_54 3m HORN 91200-HF HORIZONTAL</p>	<p>Left blank</p>



15.4	2.4GHz 2400~2483.5MHz Band Edge @ 3m	
	15.4 CH18 2440MHz - L	
	Vertical	Fundamental
Peak	<p>Site : 03CH11-HY Condition : PEAK BE 74 3m HORN 91200-HF VERTICAL</p>	<p>Site : 03CH11-HY Condition : PEAK 74 3m HORN 91200-HF VERTICAL</p>
Avg.	<p>Site : 03CH11-HY Condition : AVG BE 54 3m HORN 91200-HF VERTICAL</p>	<p>Site : 03CH11-HY Condition : AVG 54 3m HORN 91200-HF VERTICAL</p>

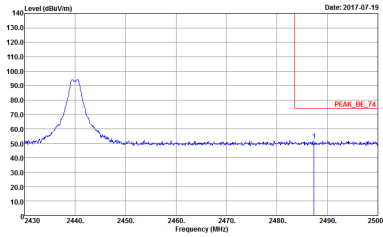
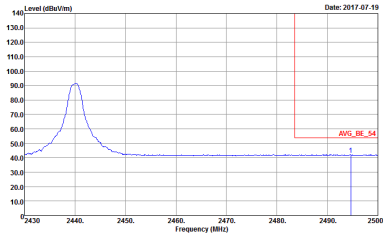

15.4	2.4GHz 2400~2483.5MHz Band Edge @ 3m	
15.4 CH18 2440MHz - R		
	Vertical	Fundamental
Peak	 <p>Site : 03CHI1-HY Condition : PEAK_BE_74 3m HORN 91200-HF VERTICAL</p>	Left blank
Avg.	 <p>Site : 03CHI1-HY Condition : AVG_BE_54 3m HORN 91200-HF VERTICAL</p>	Left blank



15.4	2.4GHz 2400~2483.5MHz Band Edge @ 3m	
15.4 CH25 2475MHz		
	Horizontal	Fundamental
<p>Peak</p>	<p>Site : 03CH11-HY Condition : PEAK BE 74 3m HORN 91200-HF HORIZONTAL</p>	<p>Site : 03CH11-HY Condition : PEAK 74 3m HORN 91200-HF HORIZONTAL</p>
<p>Avg.</p>	<p>Site : 03CH11-HY Condition : AVG BE 54 3m HORN 91200-HF HORIZONTAL</p>	<p>Site : 03CH11-HY Condition : AVG 54 3m HORN 91200-HF HORIZONTAL</p>

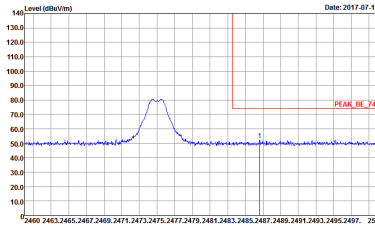
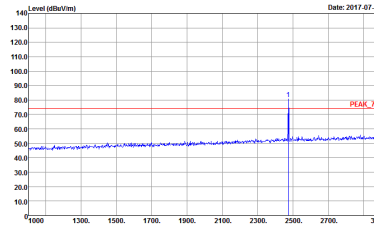
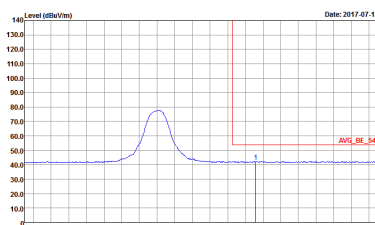
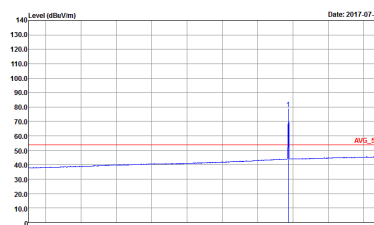

15.4	2.4GHz 2400~2483.5MHz Band Edge @ 3m	
15.4 CH25 2475MHz		
Vertical		Fundamental
Peak	 <p>Date: 2017.07.19</p> <p>Site : 03CH11-HY Condition : PEAK BE 74 3m HORN 91200-HF VERTICAL</p>	 <p>Date: 2017.07.19</p> <p>Site : 03CH11-HY Condition : PEAK 74 3m HORN 91200-HF VERTICAL</p>
Avg.	 <p>Date: 2017.07.19</p> <p>Site : 03CH11-HY Condition : AVG BE 54 3m HORN 91200-HF VERTICAL</p>	 <p>Date: 2017.07.19</p> <p>Site : 03CH11-HY Condition : AVG 54 3m HORN 91200-HF VERTICAL</p>



2.4GHz 2400~2483.5MHz

15.4 (Harmonic @ 3m)

15.4	2.4GHz 2400~2483.5MHz Harmonic @ 3m	
	15.4 Ch11 2405MHz	
	Horizontal	Vertical
Peak Avg.		



15.4	2.4GHz 2400~2483.5MHz Harmonic @ 3m	
	15.4 CH18 2440MHz	
	Horizontal	Vertical
Peak Avg.	<p>Site : 03CH11-4Y Condition : PEAK 74 3m 9170 5HF HORM 150809 HORIZONTAL</p>	<p>Site : 03CH11-4Y Condition : PEAK 74 3m 9170 5HF HORM 150809 VERTICAL</p>



15.4	2.4GHz 2400~2483.5MHz Harmonic @ 3m	
	15.4 CH25 2475MHz	
	Horizontal	Vertical
Peak	<p>Site : 03CH11-4Y Condition : PEAK 74 3m 9170 5HF HORM 150809 HORIZONTAL</p>	<p>Site : 03CH11-4Y Condition : PEAK 74 3m 9170 5HF HORM 150809 VERTICAL</p>



Emission below 1GHz

2.4GHz 15.4 (LF)

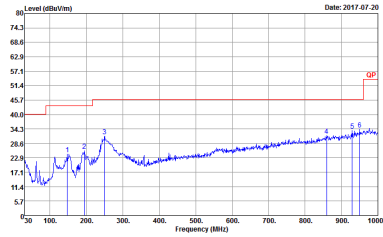
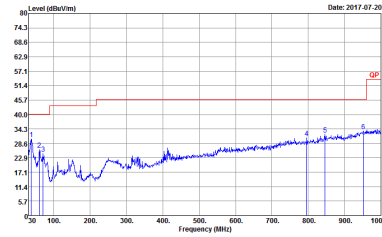
15.4	2.4GHz 2400~2483.5MHz	
15.4 LF		
Horizontal	Vertical	
QP / Peak	 <p data-bbox="430 907 686 929">Site : 03CH11-14Y Condition : QP-3m RE-LOG 6111D-LF ETC HORIZONTAL</p>	 <p data-bbox="901 907 1157 929">Site : 03CH11-14Y Condition : QP-3m RE-LOG 6111D-LF ETC VERTICAL</p>