

FCC Test Report

FCC ID : ZQANC211
Equipment : Nest Cam Outdoor
Brand Name : Nest Labs
Model Name : A0033
Applicant : Nest Labs Inc.
3400 Hillview Ave, Palo Alto, CA 94304 USA
Manufacturer : Nest Labs Inc.
3400 Hillview Ave, Palo Alto, CA 94304 USA
Standard : 47 CFR FCC Part 15.247

The product was received on Sep. 21, 2018, and testing was started from Jan. 22, 2019 and completed on Mar. 04, 2019. We, SPORTON INTERNATIONAL INC. EMC & Wireless Communications Laboratory, would like to declare that the tested sample has been evaluated in accordance with the procedures given in ANSI C63.10-2013 and shown compliance with the applicable technical standards.

The report must not be used by the client to claim product certification, approval, or endorsement by TAF or any agency of government.

The test results in this report apply exclusively to the tested model / sample. Without written approval of SPORTON INTERNATIONAL INC. EMC & Wireless Communications Laboratory, the test report shall not be reproduced except in full.



Approved by: Allen Lin

SPORTON INTERNATIONAL INC. EMC & Wireless Communications Laboratory

No. 52, Huaya 1st Rd., Guishan Dist., Taoyuan City, Taiwan (R.O.C.)



Table of Contents

HISTORY OF THIS TEST REPORT3

SUMMARY OF TEST RESULT4

1 GENERAL DESCRIPTION5

1.1 Information.....5

1.2 Testing Applied Standards7

1.3 Testing Location Information7

1.4 Measurement Uncertainty7

2 TEST CONFIGURATION OF EUT.....8

2.1 Test Condition8

2.2 Test Channel Mode8

2.3 The Worst Case Measurement Configuration.....8

2.4 Accessories and Support Equipment9

2.5 Test Setup Diagram10

3 TRANSMITTER TEST RESULT12

3.1 AC Power-line Conducted Emissions12

3.2 DTS Bandwidth.....13

3.3 Maximum Conducted Output Power14

3.4 Power Spectral Density16

3.5 Emissions in Non-restricted Frequency Bands17

3.6 Emissions in Restricted Frequency Bands.....18

4 TEST EQUIPMENT AND CALIBRATION DATA.....21

APPENDIX A. TEST RESULTS OF AC POWER-LINE CONDUCTED EMISSIONS

APPENDIX B. TEST RESULTS OF DTS BANDWIDTH

APPENDIX C. TEST RESULTS OF MAXIMUM CONDUCTED OUTPUT POWER

APPENDIX D. TEST RESULTS OF POWER SPECTRAL DENSITY

APPENDIX E. TEST RESULTS OF EMISSIONS IN NON-RESTRICTED FREQUENCY BANDS

APPENDIX F. TEST RESULTS OF EMISSIONS IN RESTRICTED FREQUENCY BANDS

APPENDIX G. TEST PHOTOS

PHOTOGRAPHS OF EUT V01



History of this test report

Report No.	Version	Description	Issued Date
FR720943-03AL	01	Initial issue of report	Feb. 21, 2019
FR720943-03AL	02	Revise typo	Mar. 05, 2019
FR720943-03AL	02	Modified Radiated Emissions below 30MHz	Mar. 13, 2019



Summary of Test Result

Report Clause	Ref. Std. Clause	Test Items	Result (PASS/FAIL)	Remark
1.1.2	15.203	Antenna Requirement	PASS	FCC 15.203
3.1	15.207	AC Power-line Conducted Emissions	PASS	FCC 15.207
3.2	15.247(a)	DTS Bandwidth	PASS	≥500kHz
3.3	15.247(b)	Maximum Conducted Output Power	PASS	Power [dBm]:30
3.4	15.247(e)	Power Spectral Density	PASS	PSD [dBm/3kHz]:8
3.5	15.247(d)	Emissions in Non-restricted Frequency Bands	PASS	Non-Restricted Bands: >30 dBc
3.6	15.247(d)	Emissions in Restricted Frequency Bands	PASS	Restricted Bands: FCC 15.209

Declaration of Conformity:
The test results with all measurement uncertainty excluded are presented in accordance with the regulation limits or requirements declared by manufacturers.
Comments and explanations:
None

Reviewed by: Jackson Tsai

Report Producer: Ann Hou

1 General Description

1.1 Information

1.1.1 RF General Information

Frequency Range (MHz)	Bluetooth Mode	Ch. Frequency (MHz)	Channel Number
2400-2483.5	LE	2402-2480	0-39 [40]

Band	Mode	BWch (MHz)	Nant
2.4-2.4835GHz	BT-LE(1Mbps)	1.0	1TX

Note:

- ♦ Bluetooth LE uses a GFSK (1Mbps) modulation for DSSS.
- ♦ BWch is the nominal channel bandwidth.

1.1.2 Antenna Information

Ant.	Port	Brand	Model Name	Antenna Type	Connector
1	1	-	-	PIFA	I-PEX

Ant.	Gain (dBi)		
	2.4G	5G	BT
1	0.84	2.45	0.84

Note 1: The EUT has one antenna.

For 2.4GHz function:

For IEEE 802.11 b/g/n mode (1TX/1RX)

Ant. 1 (port 1) could transmit/receive simultaneously.

For BT function:

For IEEE 802.15.1 Bluetooth mode (1TX/1RX)

Ant. 1 (port 1) could transmit/receive simultaneously.

For 5GHz function:

For IEEE 802.11 a mode (1TX/1RX)

Ant. 1 (port 1) could transmit/receive simultaneously.



1.1.3 EUT Information

Operational Condition	
EUT Power Type	From AC Adapter / Host System
EUT Function	<input checked="" type="checkbox"/> Point-to-multipoint <input type="checkbox"/> Point-to-point
Type of EUT	
<input checked="" type="checkbox"/> Stand-alone	
<input type="checkbox"/> Combined (EUT where the radio part is fully integrated within another device)	
	Combined Equipment - Brand Name / Model No.: ...
<input type="checkbox"/> Plug-in radio (EUT intended for a variety of host systems)	
	Host System - Brand Name / Model No.: ...
<input type="checkbox"/> Other:	

1.1.4 Mode Test Duty Cycle

Mode	DC	DCF(dB)	T(s)	VBW(Hz) ≥ 1/T
BT-LE(1Mbps)	0.654	1.844	410u	3k

Note. If DC < 0.98, the DCF was added while measuring Output power and PSD.

1.2 Testing Applied Standards

According to the specifications of the manufacturer, the EUT must comply with the requirements of the following standards:

- ◆ 47 CFR FCC Part 15
- ◆ ANSI C63.10-2013
- ◆ KDB 558074 D01 v05r01

1.3 Testing Location Information

Testing Location			
<input checked="" type="checkbox"/>	HWA YA	ADD : No. 52, Huaya 1st Rd., Guishan Dist., Taoyuan City, Taiwan (R.O.C.)	
		TEL : 886-3-327-3456	FAX : 886-3-327-0973
Test site Designation No. TW1190 with FCC.			
<input type="checkbox"/>	JHUBEI	ADD : No.8, Ln. 724, Bo'ai St., Zhubei City, Hsinchu County, Taiwan (R.O.C.)	
		TEL : 886-3-656-9065	FAX : 886-3-656-9085
Test site Designation No. TW0006 with FCC.			

Test Condition	Test Site No.	Test Engineer	Test Environment	Test Date
AC Conduction	CO04-HY	Lego	21~22.5°C / 62~65%	23/Jan/2019
RF Conducted	TH06-HY	Streak	23~23.3°C / 66~69%	23/Jan/2019
Radiated	03CH02-HY	Patrick	22.5~24.5°C / 53.7~56.5%	22/Jan/2019~ 02/Feb/2019
Radiated (9kHz~30MHz)	03CH02-HY	Patrick	23.2~25.1°C / 55.6~57.2%	04/Mar/2019

1.4 Measurement Uncertainty

ISO/IEC 17025 requires that an estimate of the measurement uncertainties associated with the emissions test results be included in the report. The measurement uncertainties given below are based on a 95% confidence level (based on a coverage factor (k=2))

Test Items	Uncertainty	Remark
Conducted Emission (150kHz ~ 30MHz)	3.54 dB	Confidence levels of 95%
Radiated Emission (9kHz ~ 30MHz)	1.6 dB	Confidence levels of 95%
Radiated Emission (30MHz ~ 1,000MHz)	4.3 dB	Confidence levels of 95%
Radiated Emission (1GHz ~ 18GHz)	3.9 dB	Confidence levels of 95%
Radiated Emission (18GHz ~ 40GHz)	3.5 dB	Confidence levels of 95%
Conducted Emission	1.3 dB	Confidence levels of 95%
Temperature	0.7 °C	Confidence levels of 95%
Humidity	4 %	Confidence levels of 95%

2 Test Configuration of EUT

2.1 Test Condition

RF Conducted	Abbreviation	Remark
TnomVnom	Tnom	20°C
-	Vnom	5V

2.2 Test Channel Mode



Test Software	CMD

Mode	Power Setting
BT-LE(1Mbps)	-
2402MHz	default
2440MHz	default
2480MHz	default

2.3 The Worst Case Measurement Configuration

The Worst Case Mode for Following Conformance Tests	
Tests Item	AC power-line conducted emissions
Condition	AC power-line conducted measurement for line and neutral
Operating Mode	CTX
1	Adapter mode
2	USB mode

The Worst Case Mode for Following Conformance Tests	
Tests Item	DTS Bandwidth Maximum Conducted Output Power Power Spectral Density Emissions in Non-restricted Frequency Bands
Test Condition	Conducted measurement at transmit chains

The Worst Case Mode for Following Conformance Tests			
Tests Item	Emissions in Restricted Frequency Bands		
Test Condition	Radiated measurement If EUT consist of multiple antenna assembly (multiple antenna are used in EUT regardless of spatial multiplexing MIMO configuration), the radiated test should be performed with highest antenna gain of each antenna type.		
Operating Mode < 1GHz	CTX		
1	Adapter mode		
2	USB mode		
Operating Mode > 1GHz	CTX		
Orthogonal Planes of EUT	X Plane	Y Plane	Z Plane
			
Worst Planes of EUT			V

2.4 Accessories and Support Equipment

Accessories				
AC Adapter	Brand Name	I.T.E	Model Name	A0038
	Power Rating	I/P: 100- 240 Vac, 0.35 A, O/P: 5 Vdc, 1.4 A		
	Power Cord	4.4 meter, non-shielded cable, w/o ferrite core		

Reminder: Regarding to more detail and other information, please refer to user manual.

Support Equipment – RF Conducted				
No.	Equipment	Brand Name	Model Name	FCC ID
1	Notebook	DELL	E5410	DoC
2	Adapter for Notebook	DELL	HA65NM130	DoC

Support Equipment – Radiated Emission				
No.	Equipment	Brand Name	Model Name	FCC ID
1	Notebook	DELL	PP13S	DoC
2	Adapter for Notebook	DELL	LA90PM111	DoC

2.5 Test Setup Diagram

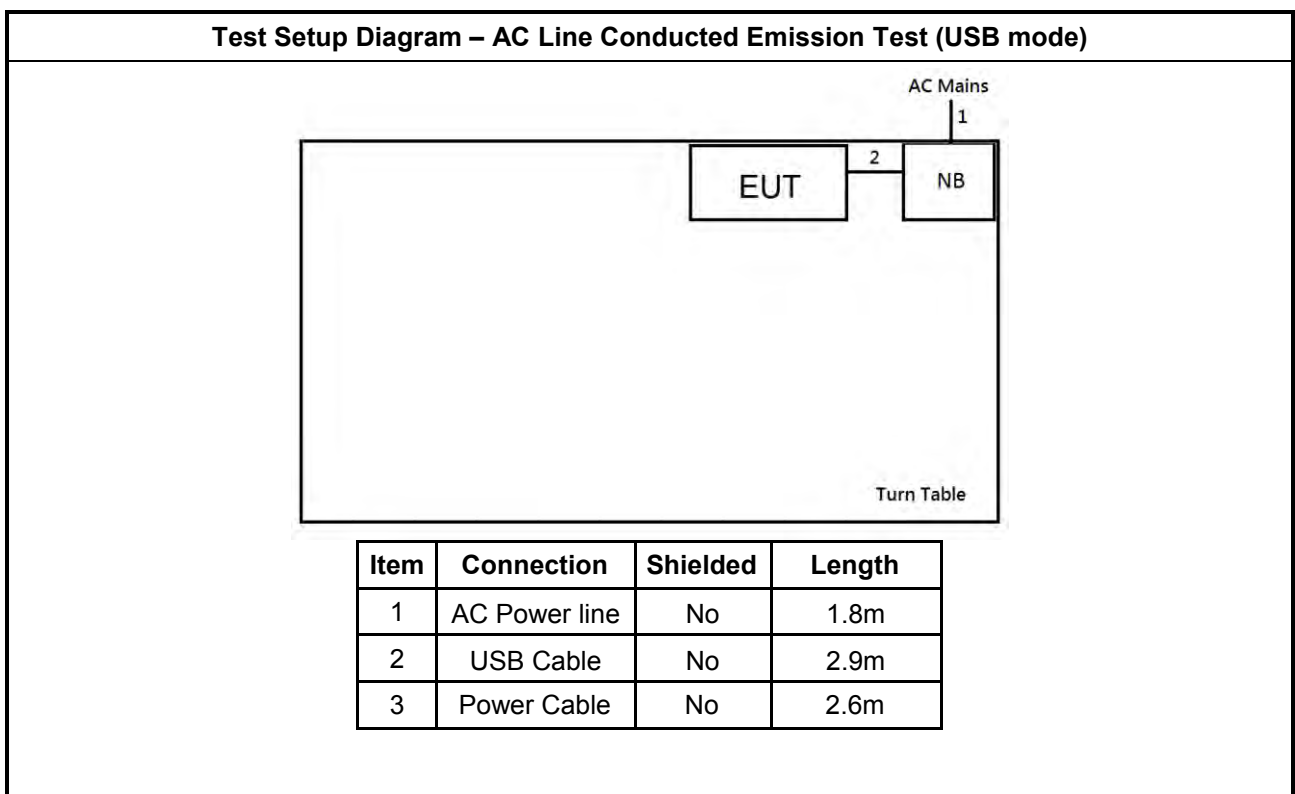
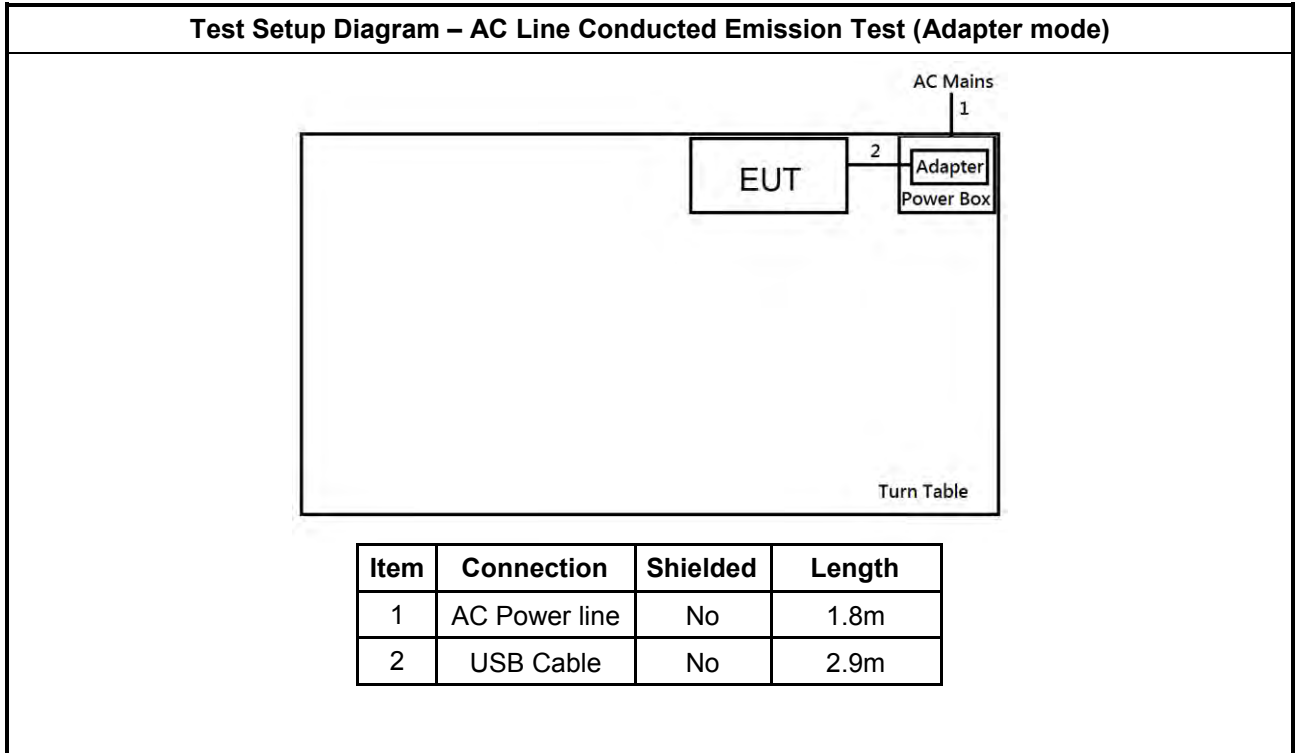

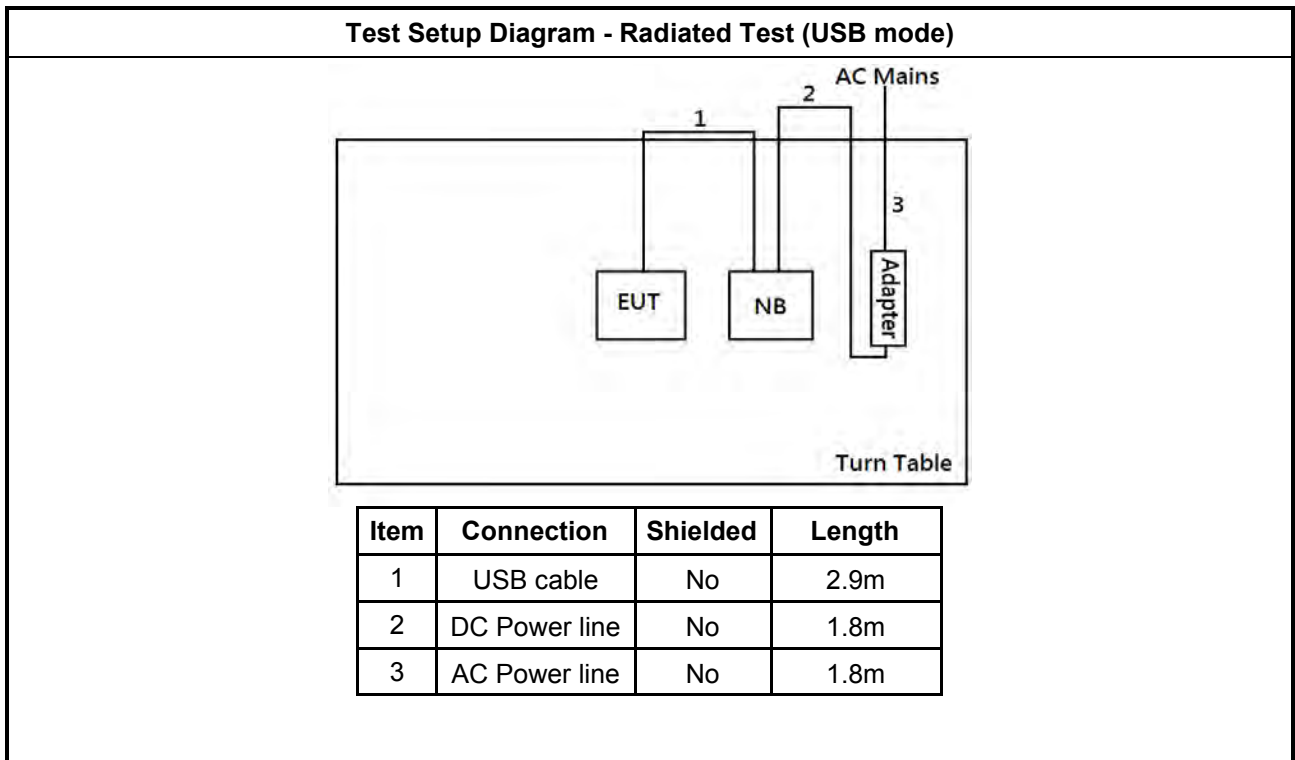
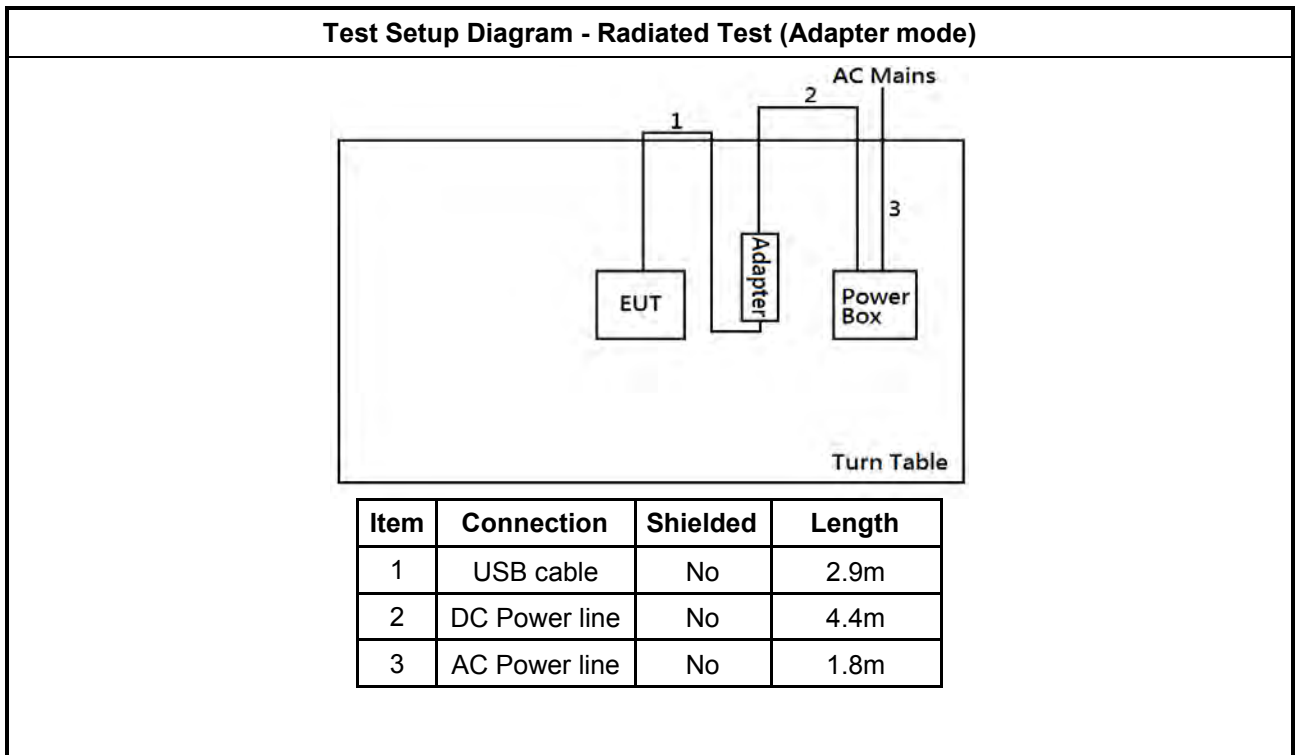

3 Transmitter Test Result

3.1 AC Power-line Conducted Emissions

3.1.1 AC Power-line Conducted Emissions Limit

AC Power-line Conducted Emissions Limit		
Frequency Emission (MHz)	Quasi-Peak	Average
0.15-0.5	66 - 56 *	56 - 46 *
0.5-5	56	46
5-30	60	50

Note 1: * Decreases with the logarithm of the frequency.

3.1.2 Measuring Instruments

Refer a test equipment and calibration data table in this test report.

3.1.3 Test Procedures

Test Method
<ul style="list-style-type: none"> Refer as ANSI C63.10-2013, clause 6.2 foray power-line conducted emissions.

3.1.4 Test Setup

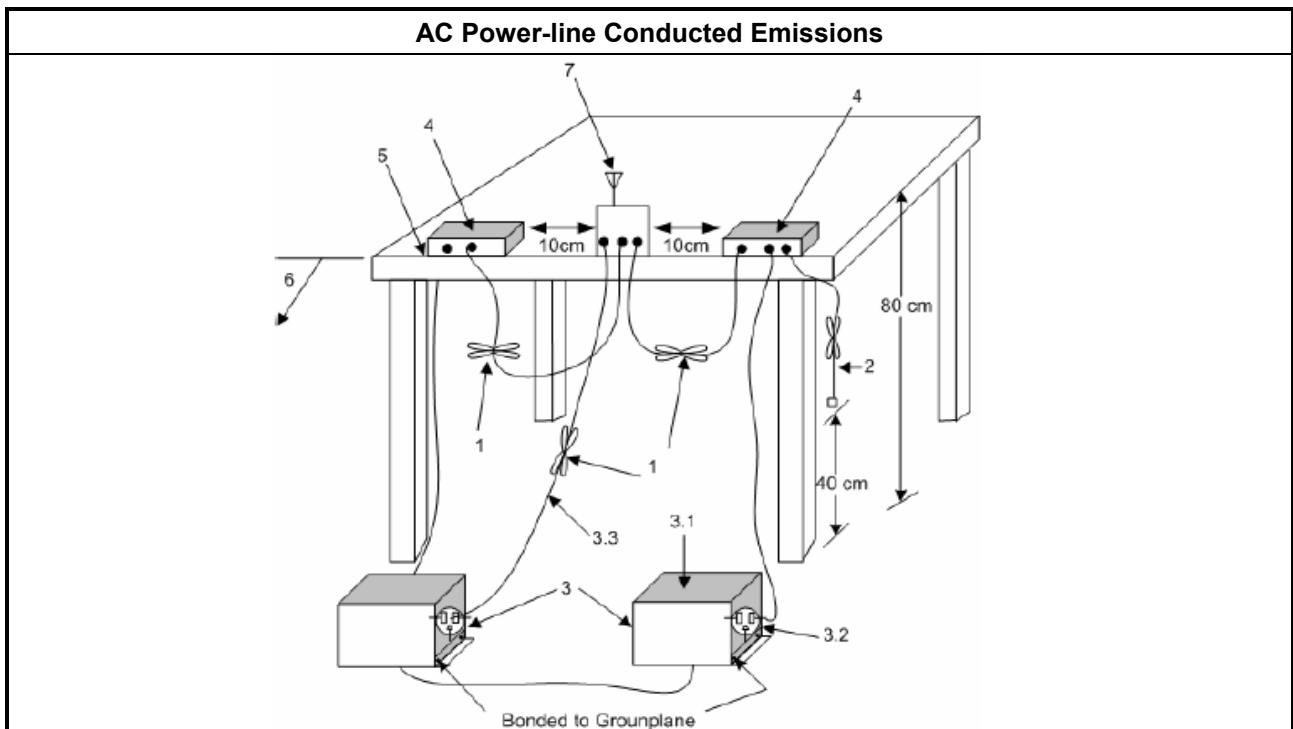

3.1.5 Test Result of AC Power-line Conducted Emissions

Refer as Appendix A

3.2 DTS Bandwidth

3.2.1 6dB Bandwidth Limit

6dB Bandwidth Limit
Systems using digital modulation techniques:
<ul style="list-style-type: none"> ▪ 6 dB bandwidth \geq 500 kHz.

3.2.2 Measuring Instruments

Refer a test equipment and calibration data table in this test report.

3.2.3 Test Procedures

Test Method
<ul style="list-style-type: none"> ▪ For the emission bandwidth shall be measured using one of the options below:
<input checked="" type="checkbox"/> Refer as KDB 558074, clause 8.2 (11.8 of ANSI C63.10) DTS bandwidth measurement.
<input type="checkbox"/> Refer as RSS-Gen, clause 6.7 for for occupied bandwidth testing.
<input type="checkbox"/> Refer as ANSI C63.10, clause 6.9.3 for occupied bandwidth testing.

3.2.4 Test Setup

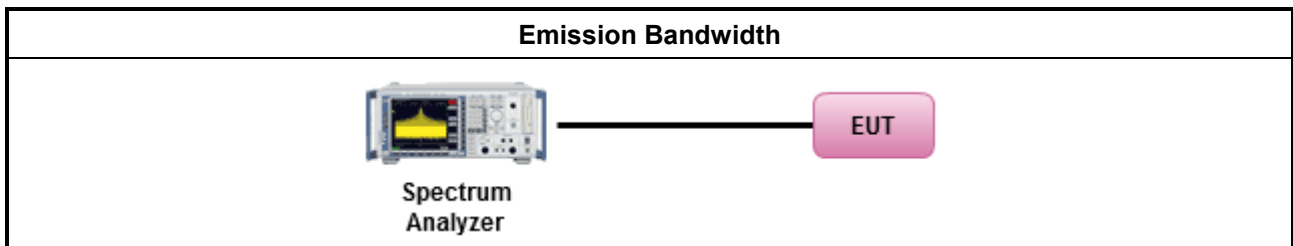

3.2.5 Test Result of Emission Bandwidth

Refer as Appendix B

3.3 Maximum Conducted Output Power

3.3.1 Maximum Conducted Output Power Limit

Maximum Conducted Output Power Limit	
	<ul style="list-style-type: none"> ▪ If $G_{TX} \leq 6$ dBi, then $P_{Out} \leq 30$ dBm (1 W)
	<ul style="list-style-type: none"> ▪ Point-to-multipoint systems (P2M): If $G_{TX} > 6$ dBi, then $P_{Out} = 30 - (G_{TX} - 6)$ dBm
	<ul style="list-style-type: none"> ▪ Point-to-point systems (P2P): If $G_{TX} > 6$ dBi, then $P_{Out} = 30 - (G_{TX} - 6)/3$ dBm
	<ul style="list-style-type: none"> ▪ Smart antenna system (SAS):
	<ul style="list-style-type: none"> - Single beam: If $G_{TX} > 6$ dBi, then $P_{Out} = 30 - (G_{TX} - 6)/3$ dBm
	<ul style="list-style-type: none"> - Overlap beam: If $G_{TX} > 6$ dBi, then $P_{Out} = 30 - (G_{TX} - 6)/3$ dBm
	<ul style="list-style-type: none"> - Aggregate power on all beams: If $G_{TX} > 6$ dBi, then $P_{Out} = 30 - (G_{TX} - 6)/3 + 8$ dBm
e.i.r.p. Power Limit:	
	<ul style="list-style-type: none"> ▪ 2400-2483.5 MHz Band
	<ul style="list-style-type: none"> ▪ Point-to-multipoint systems (P2M): $P_{eirp} \leq 36$ dBm (4 W)
	<ul style="list-style-type: none"> ▪ Point-to-point systems (P2P): $P_{eirp} \leq \text{MAX}(36, [P_{Out} + G_{TX}])$ dBm
	<ul style="list-style-type: none"> ▪ Smart antenna system (SAS)
	<ul style="list-style-type: none"> - Single beam: $P_{eirp} \leq \text{MAX}(36, P_{Out} + G_{TX})$ dBm
	<ul style="list-style-type: none"> - Overlap beam: $P_{eirp} \leq \text{MAX}(36, P_{Out} + G_{TX})$ dBm
	<ul style="list-style-type: none"> - Aggregate power on all beams: $P_{eirp} \leq \text{MAX}(36, [P_{Out} + G_{TX} + 8])$ dBm
<p>P_{Out} = maximum peak conducted output power or maximum conducted output power in dBm, G_{TX} = the maximum transmitting antenna directional gain in dBi.</p>	

3.3.2 Measuring Instruments

Refer a test equipment and calibration data table in this test report.

3.3.3 Test Procedures

Test Method	
<ul style="list-style-type: none"> ▪ Maximum Peak Conducted Output Power 	
<input type="checkbox"/>	Refer as KDB 558074, clause 8.3.1.1 (11.9.1.1 of ANSI C63.10) RBW ≥ EBW method.
<input type="checkbox"/>	Refer as KDB 558074, clause 8.3.1.2 (11.9.1.2 of ANSI C63.10) integrated band power method.
<input type="checkbox"/>	Refer as KDB 558074, clause 8.3.1.3 (11.9.1.3 of ANSI C63.10) peak power meter.
<ul style="list-style-type: none"> ▪ Maximum Average Conducted Output Power 	
<input type="checkbox"/>	Refer as KDB 558074, clause 8.3.2.2 (11.9.2.2 of ANSI C63.10) using a spectrum analyzer.
<input checked="" type="checkbox"/>	Refer as KDB 558074, clause 8.3.2.3 (11.9.2.3.1 of ANSI C63.10) using a power meter.
<ul style="list-style-type: none"> ▪ For conducted measurement. 	
<ul style="list-style-type: none"> ▪ If the EUT supports multiple transmit chains using options given below: Refer as KDB 662911, In-band power measurements. Using the measure-and-sum approach, measured all transmit ports individually. Sum the power (in linear power units e.g., mW) of all ports for each individual sample and save them. 	
<ul style="list-style-type: none"> ▪ If multiple transmit chains, EIRP calculation could be following as methods: $P_{total} = P_1 + P_2 + \dots + P_n$ (calculated in linear unit [mW] and transfer to log unit [dBm]) $EIRP_{total} = P_{total} + DG$ 	

3.3.4 Test Setup

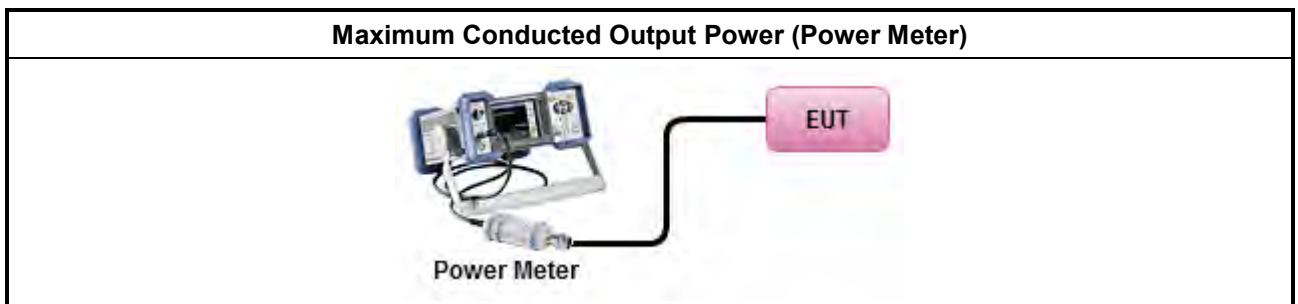

3.3.5 Test Result of Maximum Conducted Output Power

Refer as Appendix C

3.4 Power Spectral Density

3.4.1 Power Spectral Density Limit

Power Spectral Density Limit
<ul style="list-style-type: none"> ▪ Power Spectral Density (PSD) ≤ 8 dBm/3kHz

3.4.2 Measuring Instruments

Refer a test equipment and calibration data table in this test report.

3.4.3 Test Procedures

Test Method	
	<ul style="list-style-type: none"> ▪ Peak power spectral density procedures that the same method as used to determine the conducted output power. If maximum peak conducted output power was measured to demonstrate compliance to the output power limit, then the peak PSD procedure below (Method PKPSD) shall be used. If maximum conducted output power was measured to demonstrate compliance to the output power limit, then one of the average PSD procedures shall be used, as applicable based on the following criteria (the peak PSD procedure is also an acceptable option).
<input checked="" type="checkbox"/>	Refer as KDB 558074, clause 8.4 (11.10.2 of ANSI C63.10) Method PKPSD.
	<ul style="list-style-type: none"> ▪ For conducted measurement.
	<ul style="list-style-type: none"> ▪ If The EUT supports multiple transmit chains using options given below:
	<ul style="list-style-type: none"> ▪ Measure and sum the spectra across the outputs. Refer as KDB 662911, In-band power spectral density (PSD). Sample all transmit ports simultaneously using a spectrum analyzer for each transmit port. Where the trace bin-by-bin of each transmit port summing can be performed. (i.e., in the first spectral bin of output 1 is summed with that in the first spectral bin of output 2 and that from the first spectral bin of output 3, and so on up to the NTX output to obtain the value for the first frequency bin of the summed spectrum.). Add up the amplitude (power) values for the different transmit chains and use this as the new data trace.

3.4.4 Test Setup

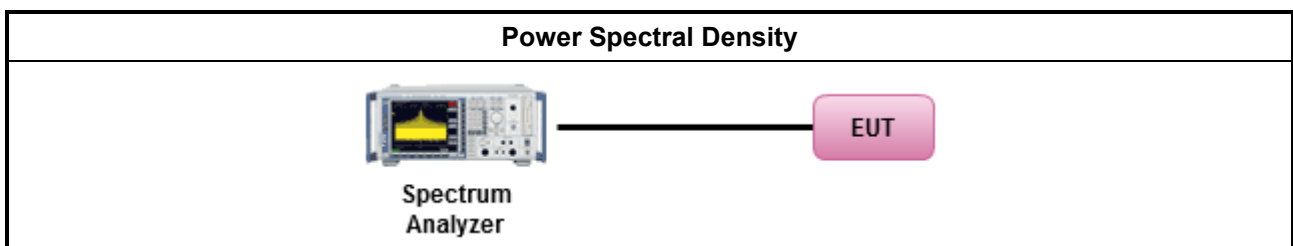

3.4.5 Test Result of Power Spectral Density

Refer as Appendix D

3.5 Emissions in Non-restricted Frequency Bands

3.5.1 Emissions in Non-restricted Frequency Bands Limit

Un-restricted Band Emissions Limit	
RF output power procedure	Limit (dB)
Peak output power procedure	20
Average output power procedure	30

Note 1: If the peak output power procedure is used to measure the fundamental emission power to demonstrate compliance to requirements, then the peak conducted output power measured within any 100 kHz outside the authorized frequency band shall be attenuated by at least 20 dB relative to the maximum measured in-band peak PSD level.

Note 2: If the average output power procedure is used to measure the fundamental emission power to demonstrate compliance to requirements, then the power in any 100 kHz outside of the authorized frequency band shall be attenuated by at least 30 dB relative to the maximum measured in-band average PSD level.

3.5.2 Measuring Instruments

Refer a test equipment and calibration data table in this test report.

3.5.3 Test Procedures

Test Method
<ul style="list-style-type: none"> Refer as KDB 558074, clause 8.5 (11.11 of ANSI C63.10) for non-restricted frequency bands.

3.5.4 Test Setup

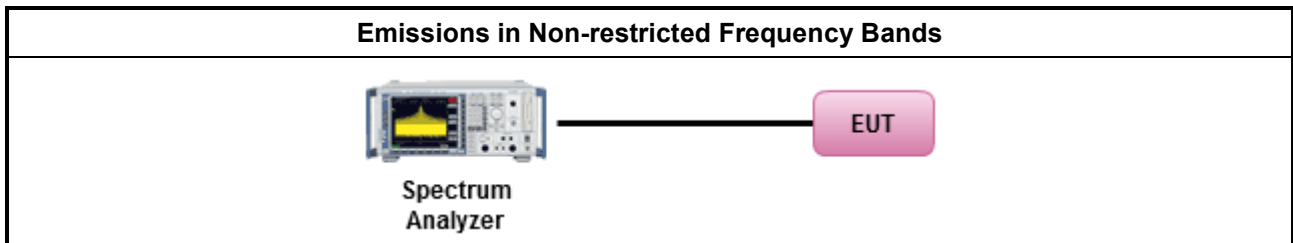

3.5.5 Test Result of Emissions in Non-restricted Frequency Bands

Refer as Appendix E

3.6 Emissions in Restricted Frequency Bands

3.6.1 Emissions in Restricted Frequency Bands Limit

Restricted Band Emissions Limit			
Frequency Range (MHz)	Field Strength (uV/m)	Field Strength (dBuV/m)	Measure Distance (m)
0.009~0.490	2400/F(kHz)	48.5 - 13.8	300
0.490~1.705	24000/F(kHz)	33.8 - 23	30
1.705~30.0	30	29	30
30~88	100	40	3
88~216	150	43.5	3
216~960	200	46	3
Above 960	500	54	3

Note 1: Test distance for frequencies at or above 30 MHz, measurements may be performed at a distance other than the limit distance provided they are not performed in the near field and the emissions to be measured can be detected by the measurement equipment. When performing measurements at a distance other than that specified, the results shall be extrapolated to the specified distance using an extrapolation factor of 20 dB/decade (inverse of linear distance for field-strength measurements, inverse of linear distance-squared for power-density measurements).

Note 2: Test distance for frequencies at below 30 MHz, measurements may be performed at a distance closer than the EUT limit distance; however, an attempt should be made to avoid making measurements in the near field. When performing measurements below 30 MHz at a closer distance than the limit distance, the results shall be extrapolated to the specified distance by either making measurements at a minimum of two or more distances on at least one radial to determine the proper extrapolation factor or by using the square of an inverse linear distance extrapolation factor (40 dB / decade). The test report shall specify the extrapolation method used to determine compliance of the EUT.

Note 3: Using the distance of 1m during the test for above 18 GHz, and the test value to correct for the distance factor at 3m.

3.6.2 Measuring Instruments

Refer a test equipment and calibration data table in this test report.

3.6.3 Test Procedures

Test Method	
<ul style="list-style-type: none"> The average emission levels shall be measured in [duty cycle \geq 98 or duty factor]. 	
<ul style="list-style-type: none"> Refer as ANSI C63.10, clause 6.10.3 band-edge testing shall be performed at the lowest frequency channel and highest frequency channel within the allowed operating band. 	
<ul style="list-style-type: none"> For the transmitter unwanted emissions shall be measured using following options below: <ul style="list-style-type: none"> Refer as KDB 558074, clause 8.6 (11.12 of ANSI C63.10) for restricted frequency bands. 	
<ul style="list-style-type: none"> For the transmitter band-edge emissions shall be measured using following options below: <ul style="list-style-type: none"> Refer as KDB 558074 clause 8.7.1, When the performing peak or average radiated measurements, emissions within 2 MHz of the authorized band edge may be measured using the marker-delta method described below. Refer as KDB 558074, clause 8.7.2 (6.10.6 of ANSI C63.10) for marker-delta method for band-edge measurements. Refer as KDB 558074, clause 8.7.3 for narrower resolution bandwidth (100kHz) using the band power and summing the spectral levels (i.e., 1 MHz). 	
<ul style="list-style-type: none"> Use the following spectrum analyzer settings: <ul style="list-style-type: none"> Set RBW=100 kHz for $f < 1$ GHz; VBW=3 * RBW; Sweep = auto; Detector function = peak; Trace = max hold. Set RBW = 1 MHz, VBW= 3MHz for $f \geq 1$ GHz for peak measurement. For average measurement, refer as 1.1.4. 	

3.6.4 Test Setup

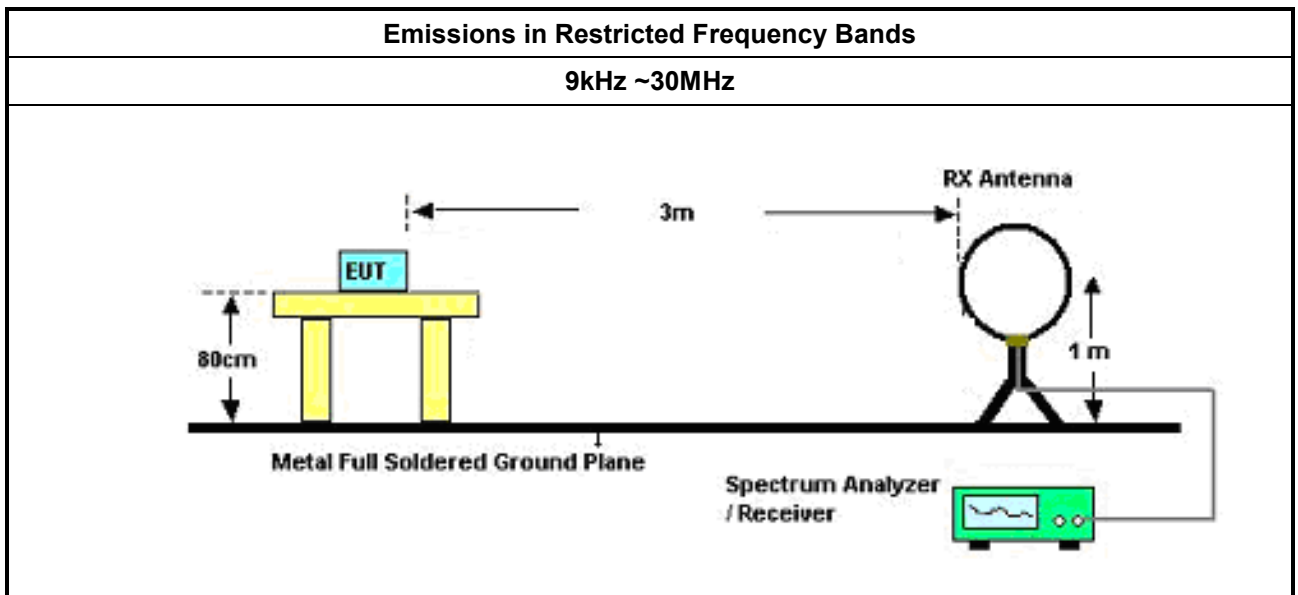

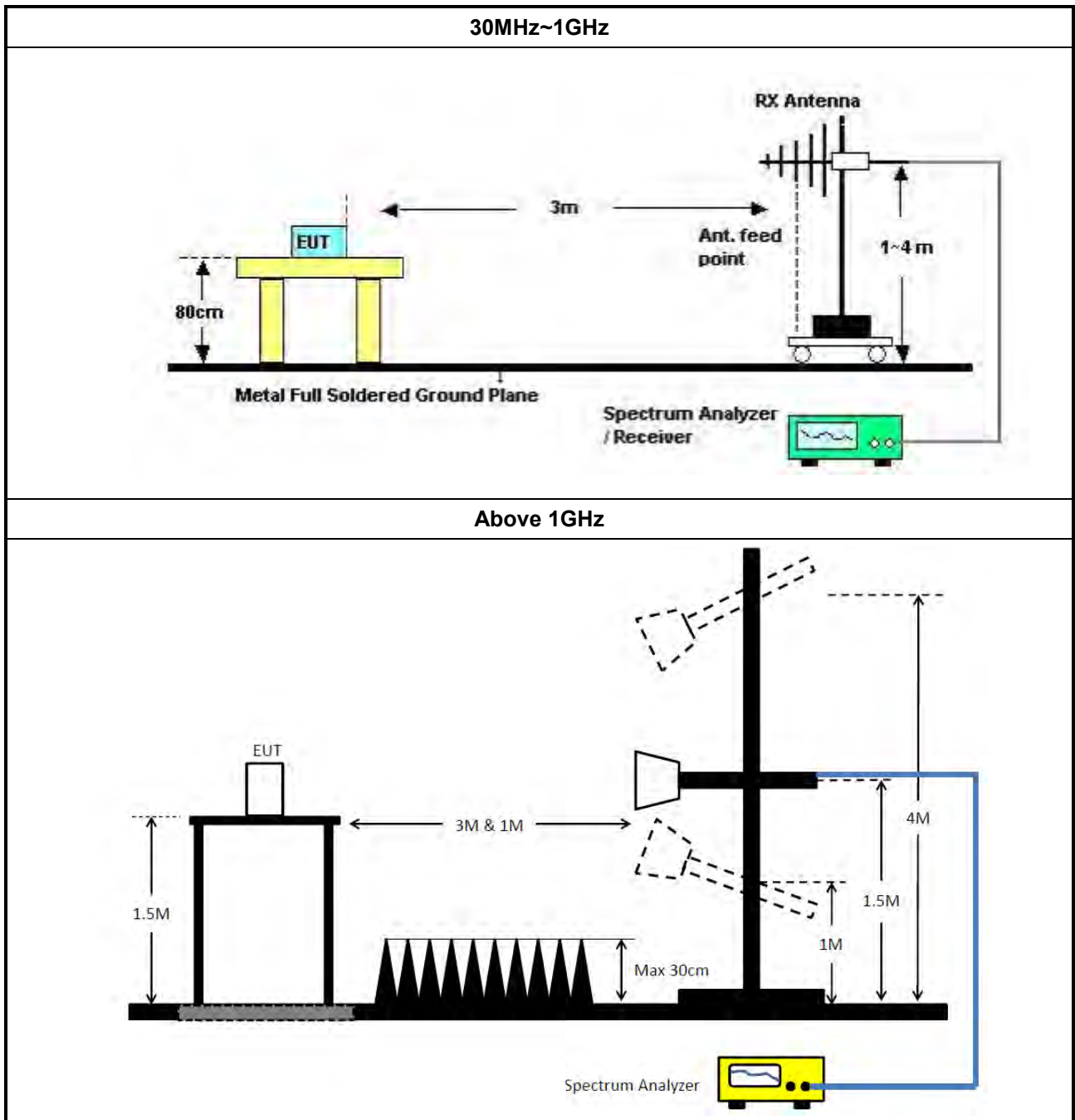

3.6.5 Test Result of Emissions in Restricted Frequency Bands (Below 30MHz)

The amplitude of spurious emissions which are attenuated by more than 20dB below the permissible value has no need to be reported.

3.6.6 Test Result of Emissions in Restricted Frequency Bands

Refer as Appendix F

4 Test Equipment and Calibration Data

Instrument for AC Conduction

Instrument	Manufacturer	Model No.	Serial No.	Spec.	Calibration Date	Calibration Due Date
EMC Receiver	R&S	ESR	102051	9KHz ~ 3.6GHz	03/May/2018	02/May/2019
LISN	R&S	ENV216	101295	9kHz ~ 30MHz	08/Nov/2018	07/Nov/2019
RF Cable-CON	MTJ	RG142	CB002-CO	9kHz ~ 200MHz	17/Sep/2018	16/Sep/2019
AC POWER	APC	AFC-11005G	F310050055	47Hz~63Hz 5~300V	NCR	NCR
Impuls Begrenzer Pulse Limiter	SCHWARZBECK	VTSD 9561-F	9561-F041	9 kHz ~ 30 MHz	12/Oct/2018	11/Oct/2019

NCR : Non-Calibration Require

Instrument for Radiated Test

Instrument	Manufacturer	Model No.	Serial No.	Spec.	Calibration Date	Calibration Due Date
3m Semi Anechoic Chamber	SIDT FRANKONIA	SAC-3M	03CH02-HY	30MHz ~ 1GHz 3m	25/Oct/2018	24/Oct/2019
3m Semi Anechoic Chamber	SIDT FRANKONIA	SAC-3M	03CH02-HY	1GHz ~ 18GHz 3m	25/Oct/2018	24/Oct/2019
Amplifier	Agilent	8447D	2944A11149	100kHz ~ 1.3GHz	27Jul/2018	02/Jul/2019
Microwave Preamplifier	Agilent	8449B	3008A02373	1GHz ~ 26.5GHz	23/Oct/2018	22/Oct/2019
Signal Analyzer	R&S	FSV40	101500	10Hz ~ 40GHz	18/Jul/2018	17/Jul/2019
EMI Test Receiver	R&S	ESR3	102052	9kHz ~ 3.6GHz	10/Apr/2018	09/Apr/2019
RF Cable-R03m	Jye Bao	RG142	CB017	9kHz ~ 1GHz	18/Jan/2019	17/Jan/2020
RF Cable-high	SUHNER	SUCOFLEX104	MY34918/4	1GHz ~ 40GHz	18/Jan/2019	17/Jan/2020
Bilog Antenna	SCHAFFNER	CBL 6112B	2723	30MHz ~ 1GHz	13/Oct/2018	12/Oct/2019
Loop Antenna	TESEQ	HLA 6120	31244	9k-30MHz	29/Mar/2018	28/Mar/2019
Broadband Horn Antenna	SCHWARZBECK	BBHA 9170	BBHA 9170221	15GHz ~ 40GHz	12/Mar/2018	11/Mar/2019
Double Ridged Guide Horn Antenna	SCHWARZBECK	BBHA 9120 D	BBHA 9120 D 01543	1GHz ~ 18GHz	11/May/2018	10/May/2019

Instrument for Conducted Test

Instrument	Manufacturer	Model No.	Serial No.	Spec.	Calibration Date	Calibration Due Date
Spectrum Analyzer	R&S	FSV 40	101013	10Hz~40GHz	05/Feb/2018	04/Feb/2019
Power Sensor	Anritsu	MA2411B	0917017	300MHz ~ 40GHz	05/Feb/2018	04/Feb/2019
Power Meter	Anritsu	ML2495A	0949003	300MHz ~ 40GHz	05/Feb/2018	04/Feb/2019
Cable 0.2m	HUBER	MY10710/4	RF Cable - 01	30MHz ~18G	10/Jan/2019	09/Jan/2020
Cable 0.2m	HUBER	MY10711/4	RF Cable - 02	30MHz ~18G	10/Jan/2019	09/Jan/2020
Cable 0.5m	HUBER	MY39470/4	RF Cable - 29	30MHz ~18G	10/Jan/2019	09/Jan/2020
SMB100A Signal Generator	R&S	SMB100A03	181147	100kHz~40GHz	12/Nov/2018	10/Nov/2020

AC Power-line Conducted Emissions Result

Operating Mode	1	Power Phase	Neutral
Operating Function	Adapter mode		

AC Conduction

23/01/2019

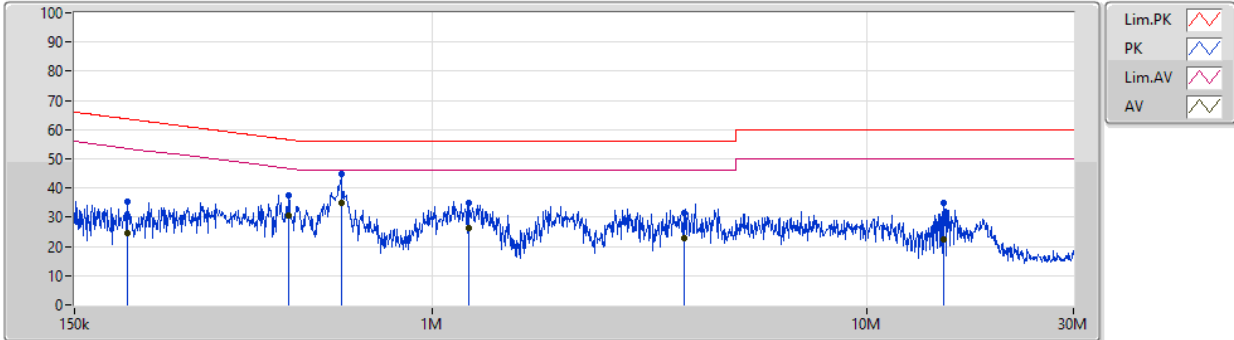

Type	Freq (Hz)	Level (dBuV)	Limit (dBuV)	Margin (dB)	Factor (dB)	Condition	Comment	Raw (dBuV)	LISN (dB)	CL (dB)	AT (dB)
QP	198.445k	35.23	63.67	-28.44	19.47	Neutral	-	15.76	9.59	0.01	9.87
AV	198.445k	24.39	53.67	-29.28	19.47	Neutral	-	4.92	9.59	0.01	9.87
QP	465.741k	37.55	56.59	-19.04	19.48	Neutral	-	18.07	9.59	0.01	9.88
AV	465.741k	30.46	46.59	-16.13	19.48	Neutral	-	10.98	9.59	0.01	9.88
QP	618.807k	44.81	56.00	-11.19	19.48	Neutral	-	25.33	9.59	0.01	9.88
AV	618.807k	34.89	46.00	-11.11	19.48	Neutral	"Worst"	15.41	9.59	0.01	9.88
QP	1.217M	35.02	56.00	-20.98	19.50	Neutral	-	15.52	9.60	0.02	9.88
AV	1.217M	26.32	46.00	-19.68	19.50	Neutral	-	6.82	9.60	0.02	9.88
QP	3.798M	31.66	56.00	-24.34	19.54	Neutral	-	12.12	9.61	0.04	9.89
AV	3.798M	22.87	46.00	-23.13	19.54	Neutral	-	3.33	9.61	0.04	9.89
QP	15.058M	35.07	60.00	-24.93	19.67	Neutral	-	15.40	9.68	0.09	9.90
AV	15.058M	22.47	50.00	-27.53	19.67	Neutral	-	2.80	9.68	0.09	9.90

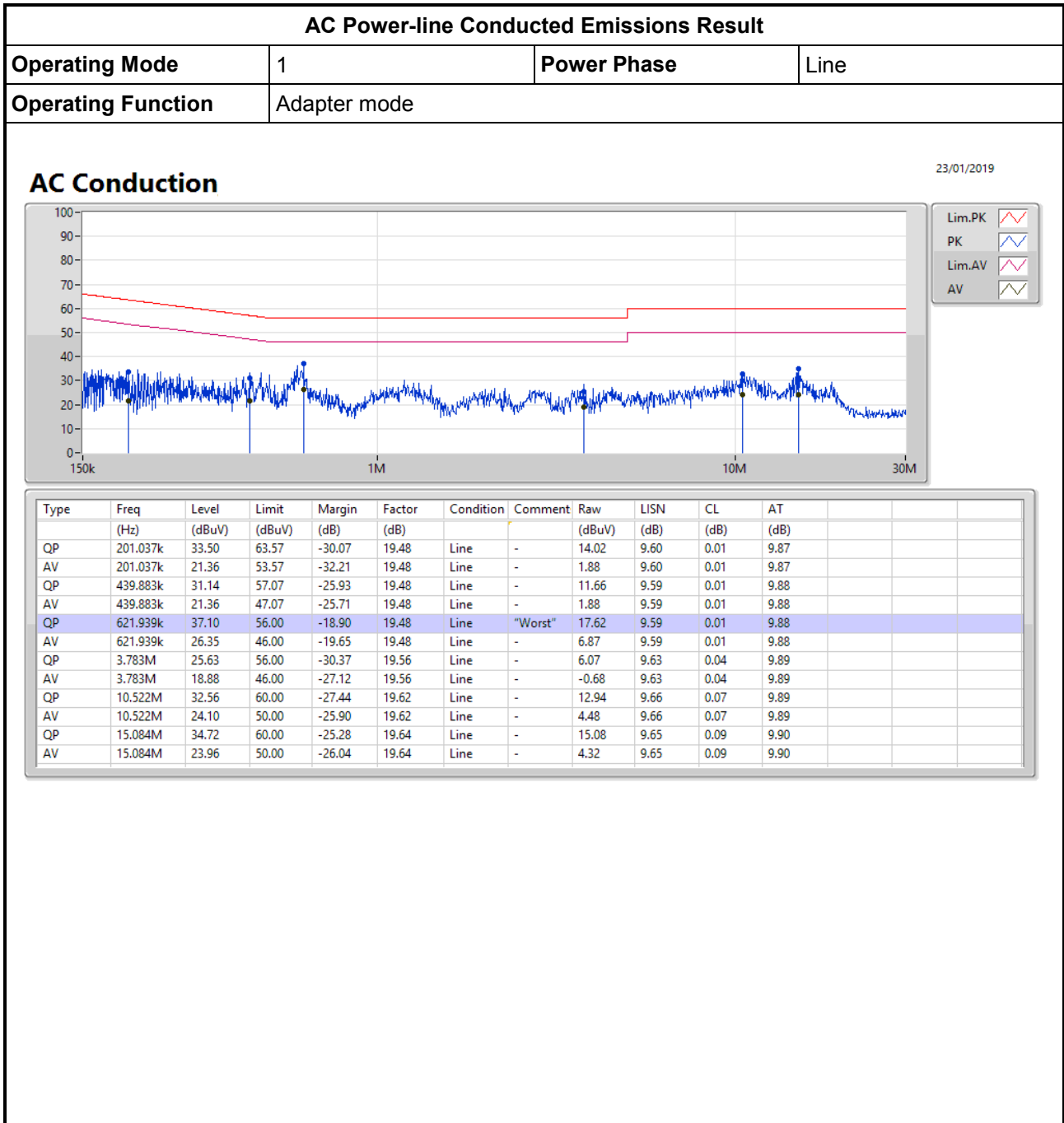

AC Power-line Conducted Emissions Result

Operating Mode	2	Power Phase	Neutral
Operating Function	USB mode		

AC Conduction

23/01/2019

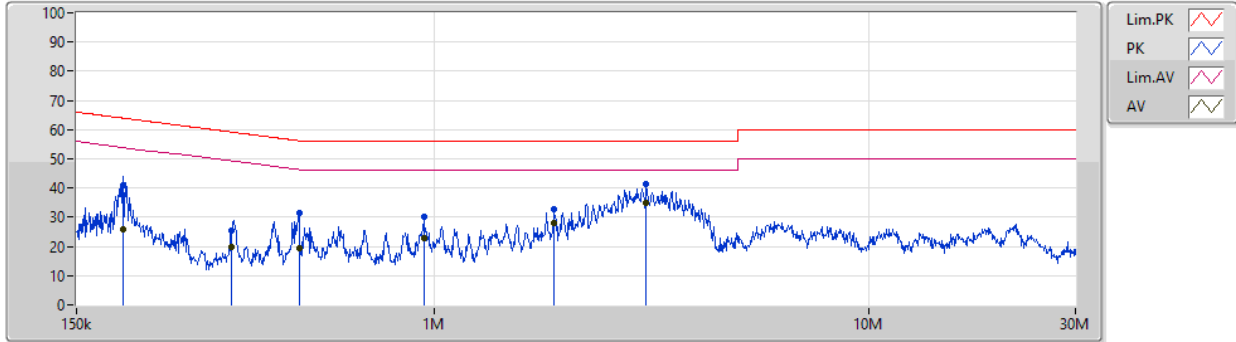

Type	Freq (Hz)	Level (dBuV)	Limit (dBuV)	Margin (dB)	Factor (dB)	Condition	Comment	Raw (dBuV)	LISN (dB)	CL (dB)	AT (dB)
QP	192.124k	41.01	63.93	-22.92	19.47	Neutral	-	21.54	9.59	0.01	9.87
AV	192.124k	25.66	53.93	-28.27	19.47	Neutral	-	6.19	9.59	0.01	9.87
QP	340.722k	25.50	59.19	-33.69	19.48	Neutral	-	6.02	9.59	0.01	9.88
AV	340.722k	19.82	49.19	-29.37	19.48	Neutral	-	0.34	9.59	0.01	9.88
QP	489.753k	31.35	56.17	-24.82	19.48	Neutral	-	11.87	9.59	0.01	9.88
AV	489.753k	19.57	46.17	-26.60	19.48	Neutral	-	0.09	9.59	0.01	9.88
QP	950.645k	30.32	56.00	-25.68	19.49	Neutral	-	10.83	9.59	0.02	9.88
AV	950.645k	22.71	46.00	-23.29	19.49	Neutral	-	3.22	9.59	0.02	9.88
QP	1.891M	32.89	56.00	-23.11	19.53	Neutral	-	13.36	9.61	0.03	9.89
AV	1.891M	27.93	46.00	-18.07	19.53	Neutral	-	8.40	9.61	0.03	9.89
QP	3.083M	41.33	56.00	-14.67	19.54	Neutral	-	21.79	9.61	0.04	9.89
AV	3.083M	34.73	46.00	-11.27	19.54	Neutral	"Worst"	15.19	9.61	0.04	9.89



AC Power-line Conducted Emissions Result

Operating Mode	2	Power Phase	Line
Operating Function	USB mode		

AC Conduction

23/01/2019

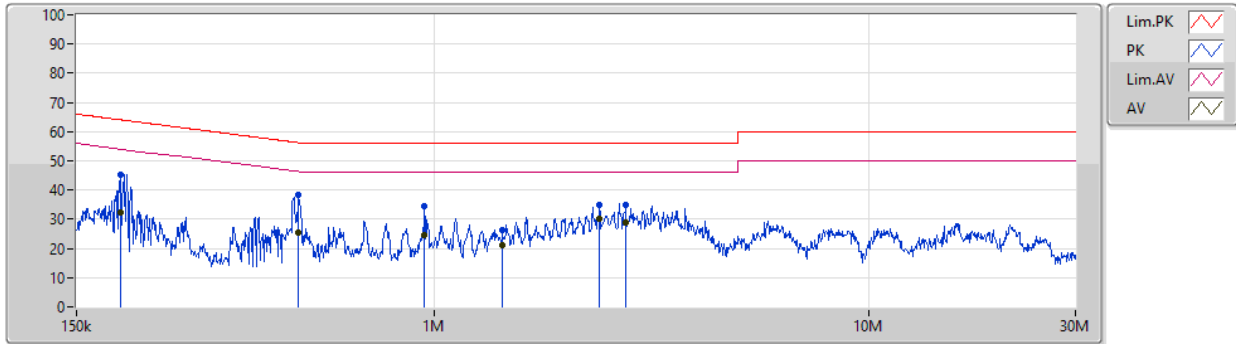

Type	Freq (Hz)	Level (dBuV)	Limit (dBuV)	Margin (dB)	Factor (dB)	Condition	Comment	Raw (dBuV)	LISN (dB)	CL (dB)	AT (dB)
QP	189.702k	45.40	64.05	-18.65	19.48	Line	-	25.92	9.60	0.01	9.87
AV	189.702k	32.16	54.05	-21.89	19.48	Line	-	12.68	9.60	0.01	9.87
QP	486.119k	38.44	56.23	-17.79	19.48	Line	-	18.96	9.59	0.01	9.88
AV	486.119k	25.55	46.23	-20.68	19.48	Line	-	6.07	9.59	0.01	9.88
QP	946.207k	34.57	56.00	-21.43	19.50	Line	-	15.07	9.60	0.02	9.88
AV	946.207k	24.53	46.00	-21.47	19.50	Line	-	5.03	9.60	0.02	9.88
QP	1.435M	26.19	56.00	-29.81	19.53	Line	-	6.66	9.61	0.03	9.89
AV	1.435M	21.22	46.00	-24.78	19.53	Line	-	1.69	9.61	0.03	9.89
QP	2.402M	35.00	56.00	-21.00	19.55	Line	-	15.45	9.62	0.04	9.89
AV	2.402M	30.36	46.00	-15.64	19.55	Line	"Worst"	10.81	9.62	0.04	9.89
QP	2.77M	34.71	56.00	-21.29	19.55	Line	-	15.16	9.62	0.04	9.89
AV	2.77M	28.76	46.00	-17.24	19.55	Line	-	9.21	9.62	0.04	9.89



Summary

Mode	Max-N dB (Hz)	Max-OBW (Hz)	ITU-Code	Min-N dB (Hz)	Min-OBW (Hz)
2.4-2.4835GHz	-	-	-	-	-
BT-LE(1Mbps)	668.75k	1.034M	1M03F1D	660k	1.032M

Max-N dB = Maximum 6dB down bandwidth; **Max-OBW** = Maximum 99% occupied bandwidth;
Min-N dB = Minimum 6dB down bandwidth; **Min-OBW** = Minimum 99% occupied bandwidth;

Result

Mode	Result	Limit (Hz)	Port 1-N dB (Hz)	Port 1-OBW (Hz)
BT-LE(1Mbps)	-	-	-	-
2402MHz	Pass	500k	660k	1.032M
2440MHz	Pass	500k	668.75k	1.032M
2480MHz	Pass	500k	661.25k	1.034M

Port X-N dB = Port X 6dB down bandwidth; **Port X-OBW** = Port X 99% occupied bandwidth;

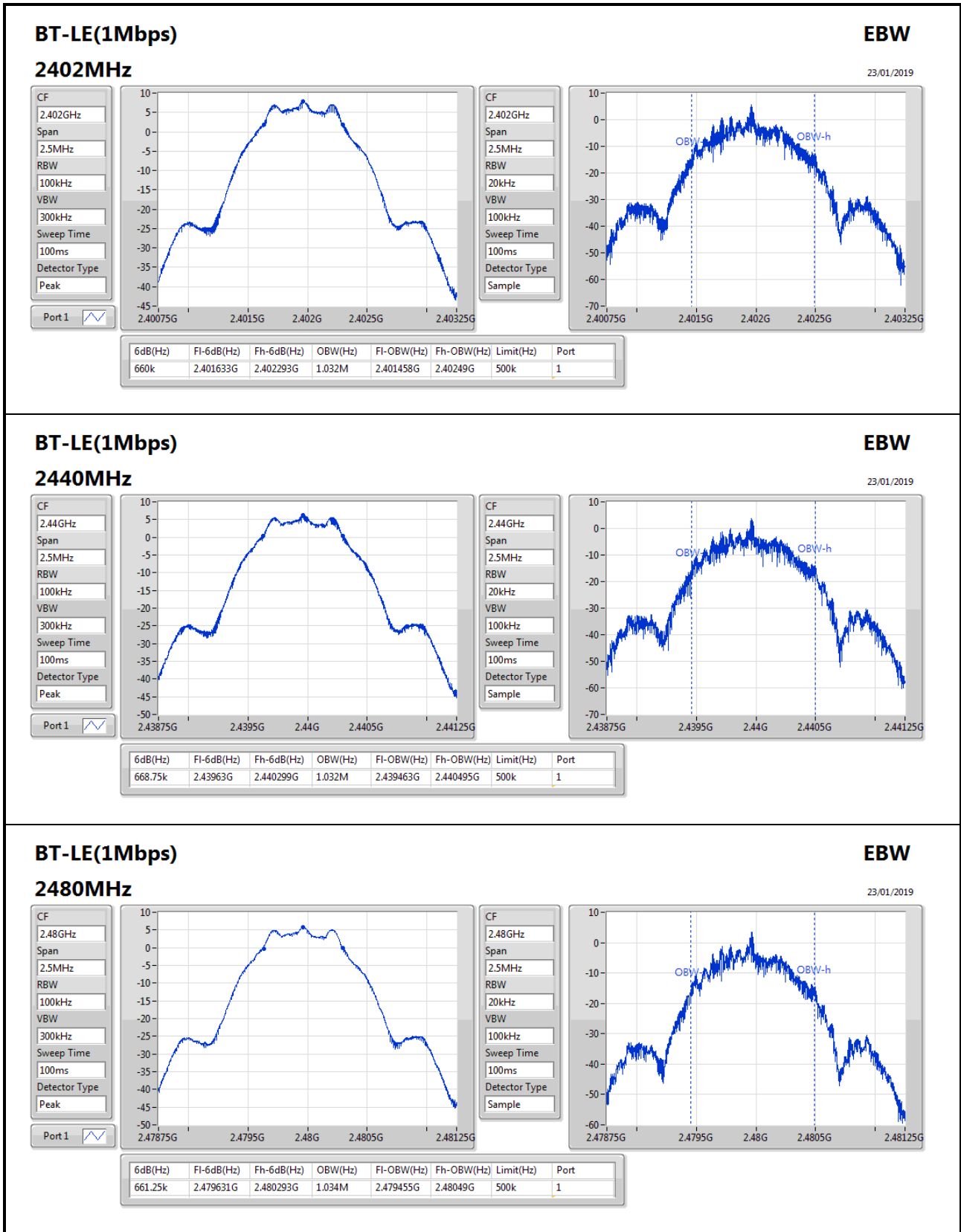



Summary

Mode	Power (dBm)	Power (W)
2.4-2.4835GHz	-	-
BT-LE(1Mbps)	7.42	0.00552

Result

Mode	Result	Gain (dBi)	Power (dBm)	Power Limit (dBm)
BT-LE(1Mbps)	-	-	-	-
2402MHz	Pass	0.84	7.42	30.00
2440MHz	Pass	0.84	5.82	30.00
2480MHz	Pass	0.84	5.35	30.00



Summary

Mode	PD (dBm/RBW)
2.4-2.4835GHz	-
BT-LE(1Mbps)	-7.38

RBW=3kHz.

Result

Mode	Result	Gain (dBi)	PD (dBm/RBW)	PD Limit (dBm/RBW)
BT-LE(1Mbps)	-	-	-	-
2402MHz	Pass	0.84	-7.38	8.00
2440MHz	Pass	0.84	-8.45	8.00
2480MHz	Pass	0.84	-10.38	8.00

RBW=3kHz.

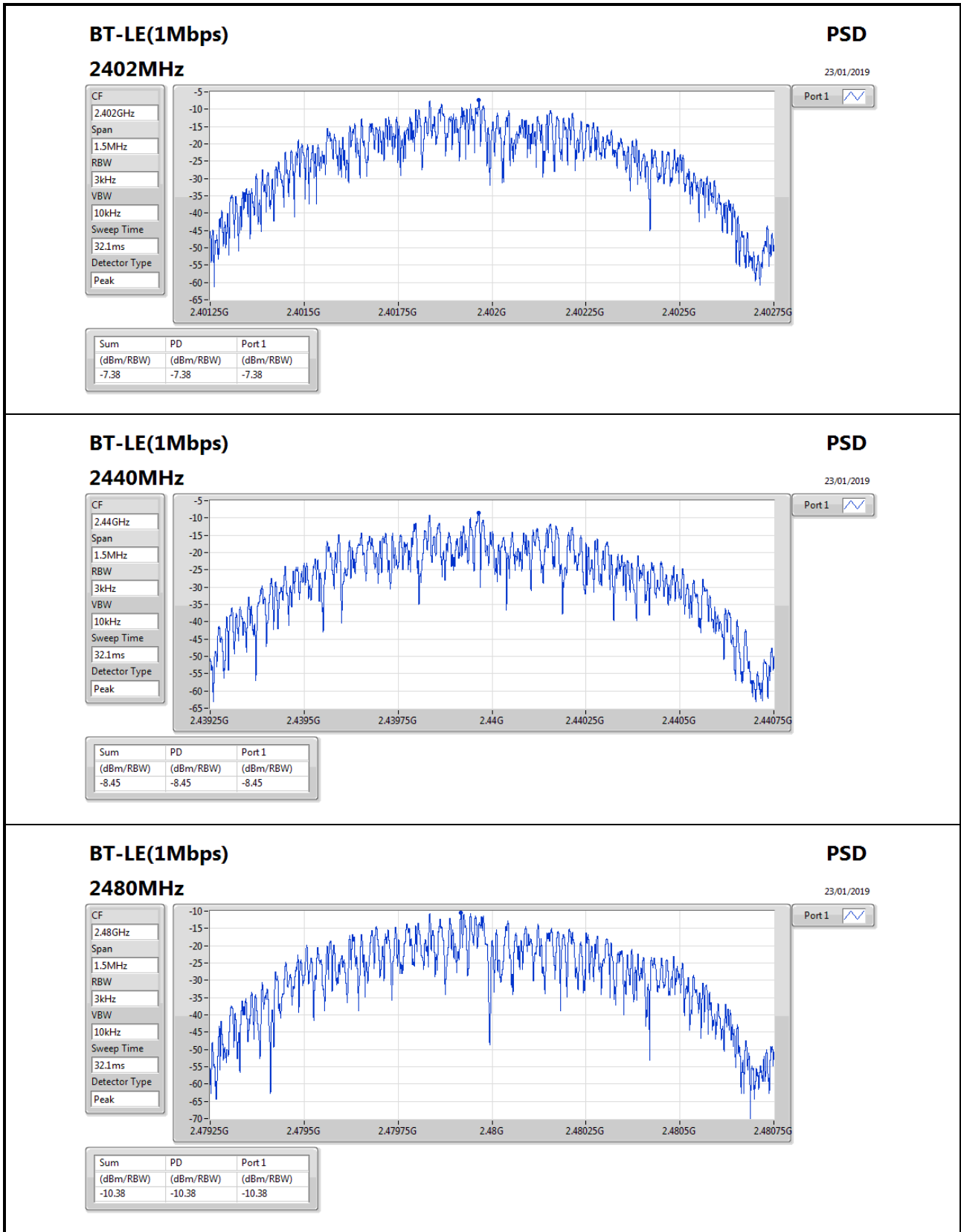



Summary

Mode	Result	Ref (Hz)	Ref (dBm)	Limit (dBm)	Freq (Hz)	Level (dBm)	Freq (Hz)	Level (dBm)	Freq (Hz)	Level (dBm)	Freq (Hz)	Level (dBm)	Port
2.4-2.4835GHz	-	-	-	-	-	-	-	-	-	-	-	-	-
BT-LE(1Mbps)	Pass	2.40171G	6.31	-23.69	2.39711G	-60.29	2.39995G	-50.36	2.48376G	-63.94	16.47263G	-52.61	1

Result

Mode	Result	Ref (Hz)	Ref (dBm)	Limit (dBm)	Freq (Hz)	Level (dBm)	Freq (Hz)	Level (dBm)	Freq (Hz)	Level (dBm)	Freq (Hz)	Level (dBm)	Port
BT-LE(1Mbps)	-	-	-	-	-	-	-	-	-	-	-	-	-
2402MHz	Pass	2.40171G	6.31	-23.69	2.39711G	-60.29	2.39995G	-50.36	2.48376G	-63.94	16.47263G	-52.61	1
2440MHz	Pass	2.40171G	6.31	-23.69	2.30417G	-64.20	2.39992G	-61.48	2.48422G	-62.74	15.32439G	-52.55	1
2480MHz	Pass	2.40171G	6.31	-23.69	2.11206G	-65.02	2.39996G	-61.61	2.48379G	-57.24	17.45201G	-51.89	1

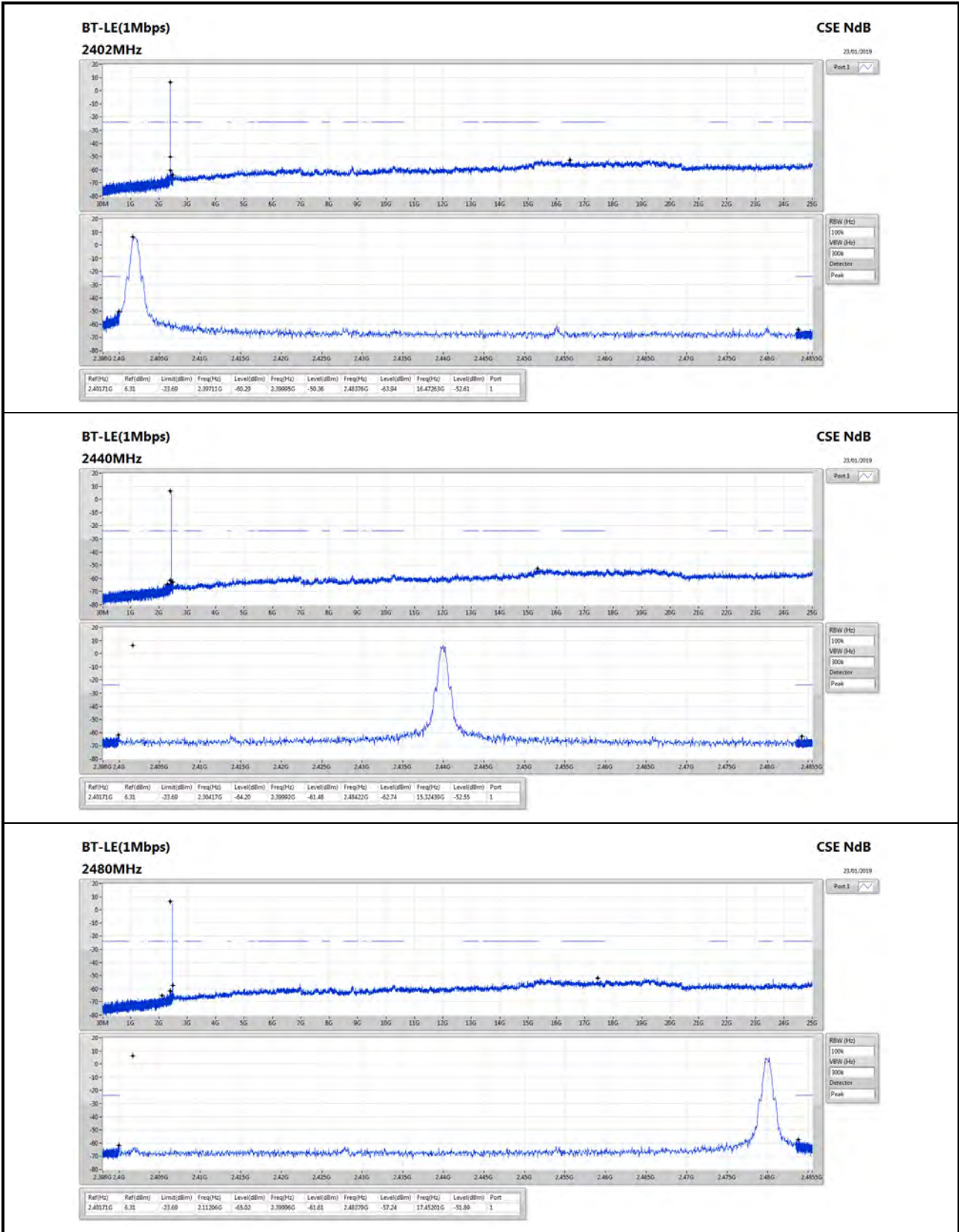



Summary

Mode	Result	Type	Freq (Hz)	Level (dBuV/m)	Limit (dBuV/m)	Margin (dB)	Factor (dB)	Dist (m)	Condition	Azimuth (°)	Height (m)	Comments
2.4-2.4835GHz	-	-	-	-	-	-	-	-	-	-	-	-
BT-LE(1Mbps)	Pass	PK	68.8M	36.87	40.00	-3.13	-15.37	3	Horizontal	360	1.00	-



Result

Mode	Result	Type	Freq (Hz)	Level (dBuV/m)	Limit (dBuV/m)	Margin (dB)	Factor (dB)	Dist (m)	Condition	Azimuth (°)	Height (m)	Comments
BT-LE(1Mbps)	-	-	-	-	-	-	-	-	-	-	-	-
2440MHz	Pass	PK	14.922k	-23.50	44.13	-67.60	21.92	300	Horizontal	360	1.00	-
2440MHz	Pass	PK	32.406k	-40.65	37.39	-78.02	21.95	300	Horizontal	360	1.00	-
2440MHz	Pass	PK	103.752k	-40.07	27.28	-67.34	20.78	300	Horizontal	360	1.00	-
2440MHz	Pass	PK	269.4k	-50.11	19.00	-69.11	20.66	300	Horizontal	0	1.00	-
2440MHz	Pass	PK	448.5k	-44.79	14.57	-59.35	20.44	300	Horizontal	0	1.00	-
2440MHz	Pass	PK	12.627M	-8.47	29.54	-37.97	22.40	30	Horizontal	0	1.00	-
2440MHz	Pass	PK	33.88M	31.22	40.00	-8.78	-6.69	3	Vertical	0	1.00	-
2440MHz	Pass	PK	113.42M	27.12	43.50	-16.38	-9.10	3	Vertical	0	1.00	-
2440MHz	Pass	PK	262.8M	22.38	46.00	-23.62	-5.85	3	Vertical	0	1.00	-
2440MHz	Pass	PK	672.14M	40.09	46.00	-5.91	-0.28	3	Vertical	0	1.00	-
2440MHz	Pass	PK	757.5M	37.09	46.00	-8.91	1.00	3	Vertical	0	1.00	-
2440MHz	Pass	PK	840.92M	36.29	46.00	-9.71	1.73	3	Vertical	0	1.00	-
2440MHz	Pass	PK	107.6M	26.55	43.50	-16.95	-9.47	3	Horizontal	360	1.00	-
2440MHz	Pass	PK	171.62M	27.49	43.50	-16.01	-10.80	3	Horizontal	360	1.00	-
2440MHz	Pass	PK	262.8M	29.16	46.00	-16.84	-5.85	3	Horizontal	360	1.00	-
2440MHz	Pass	PK	503.36M	31.61	46.00	-14.39	-2.37	3	Horizontal	360	1.00	-
2440MHz	Pass	PK	672.14M	39.27	46.00	-6.73	-0.28	3	Horizontal	360	1.00	-
2440MHz	Pass	PK	840.92M	42.31	46.00	-3.69	1.73	3	Horizontal	360	1.00	-
2440MHz	Pass	PK	11.82k	-19.22	46.15	-65.37	21.87	300	Horizontal	0	1.00	-
2440MHz	Pass	PK	29.868k	-40.52	38.10	-78.62	22.07	300	Horizontal	0	1.00	-
2440MHz	Pass	PK	91.626k	-44.14	28.36	-72.50	20.85	300	Horizontal	0	1.00	-
2440MHz	Pass	PK	209.7k	-39.40	21.17	-60.57	20.70	300	Horizontal	360	1.00	-
2440MHz	Pass	PK	687.3k	-7.23	30.86	-38.09	20.62	30	Horizontal	360	1.00	-
2440MHz	Pass	PK	1.762M	-5.11	29.54	-34.65	20.95	30	Horizontal	360	1.00	-
2440MHz	Pass	PK	41.64M	33.67	40.00	-6.33	-10.45	3	Vertical	0	1.00	-
2440MHz	Pass	PK	66.86M	32.97	40.00	-7.03	-15.49	3	Vertical	0	1.00	-
2440MHz	Pass	PK	237.58M	38.95	46.00	-7.05	-8.46	3	Vertical	0	1.00	-
2440MHz	Pass	PK	672.14M	38.28	46.00	-7.72	-0.28	3	Vertical	0	1.00	-
2440MHz	Pass	PK	757.5M	37.56	46.00	-8.44	1.00	3	Vertical	0	1.00	-
2440MHz	Pass	PK	840.92M	37.63	46.00	-8.37	1.73	3	Vertical	0	1.00	-
2440MHz	Pass	PK	41.64M	36.08	40.00	-3.92	-10.45	3	Horizontal	360	1.00	-
2440MHz	Pass	PK	68.8M	36.87	40.00	-3.13	-15.37	3	Horizontal	360	1.00	-
2440MHz	Pass	PK	672.14M	41.02	46.00	-4.98	-0.28	3	Horizontal	360	1.00	-
2440MHz	Pass	PK	757.5M	38.90	46.00	-7.10	1.00	3	Horizontal	360	1.00	-
2440MHz	Pass	PK	840.92M	40.77	46.00	-5.23	1.73	3	Horizontal	360	1.00	-
2440MHz	Pass	QP	239.52M	36.56	46.00	-9.44	-8.23	3	Horizontal	228	1.29	-



BT-LE(1Mbps)

2440MHz_Adapter

04/03/2019

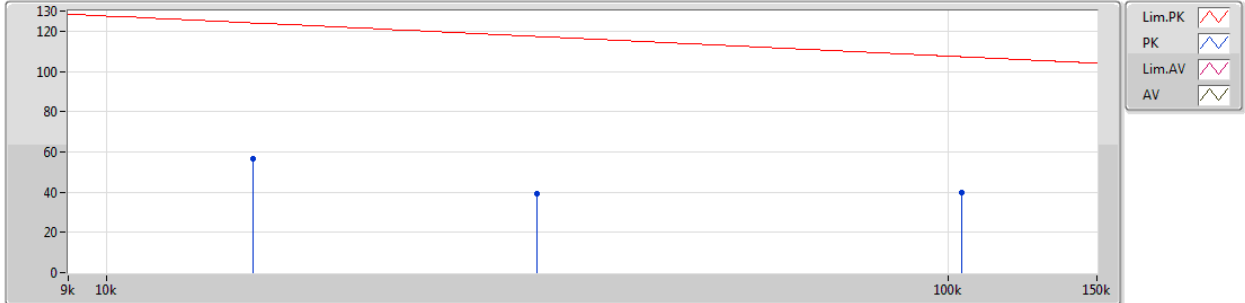

Type	Freq (Hz)	Level (dBuV/m)	Factor (dB)	Dist (m)	Condition	Azimuth (°)	Height (m)	Comments
PK	14.922k	56.50	21.92	3	Horizontal	360	1.00	-
PK	32.406k	39.35	21.95	3	Horizontal	360	1.00	-
PK	103.752k	39.93	20.78	3	Horizontal	360	1.00	-

Frequency (kHz)	Level (dBuV/m)	Level (dBuV/m)	limit (dBuV/m)	Margin
14.922	56.5 @ 3 m	-23.50 @ 300m	44.13	-67.63
32.406	39.35 @ 3 m	-40.65 @ 300m	37.39	-78.04
103.752	39.93 @ 3 m	-40.07 @ 300m	27.28	-67.35



BT-LE(1Mbps)

2440MHz_Adapter

04/03/2019

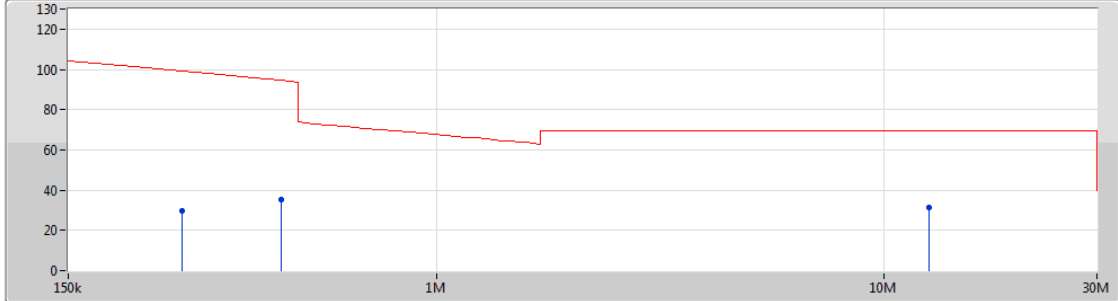

Lim.PK
 PK
 Lim.AV
 AV

Type	Freq (Hz)	Level (dBuV/m)	Factor (dB)	Dist (m)	Condition	Azimuth (°)	Height (m)	Comments
PK	269.4k	29.89	20.66	3	Horizontal	0	1.00	-
PK	448.5k	35.21	20.44	3	Horizontal	0	1.00	-
PK	12.627M	31.53	22.40	3	Horizontal	0	1.00	-

Frequency (kHz)	Level (dBuV/m)	Level (dBuV/m)	limit (dBuV/m)	Margin
269.4	29.89 @ 3 m	-50.11 @ 300m	19.00	-69.11
448.5	35.21 @ 3 m	-44.79 @ 300m	14.57	-59.36
12627	31.53 @ 3 m	-8.47 @ 30m	29.54	-38.01

BT-LE(1Mbps)

2440MHz_Adapter

22/01/2019



Legend for the plot:

- Lim.PK
- PK
- Lim.AV
- AV

Type	Freq [Hz]	Level [dBuV/m]	Limit [dBuV/m]	Margin [dB]	Factor [dB]	Dist [m]	Condition	Azimuth [°]	Height [m]	Comments
PK	33.88M	31.22	40.00	-8.78	-6.69	3	Vertical	0	1.00	-
PK	113.42M	27.12	43.50	-16.38	-9.10	3	Vertical	0	1.00	-
PK	262.8M	22.38	46.00	-23.62	-5.85	3	Vertical	0	1.00	-
PK	672.14M	40.09	46.00	-5.91	-0.28	3	Vertical	0	1.00	-
PK	757.5M	37.09	46.00	-8.91	1.00	3	Vertical	0	1.00	-
PK	840.92M	36.29	46.00	-9.71	1.73	3	Vertical	0	1.00	-

BT-LE(1Mbps)

2440MHz_Adapter

22/01/2019

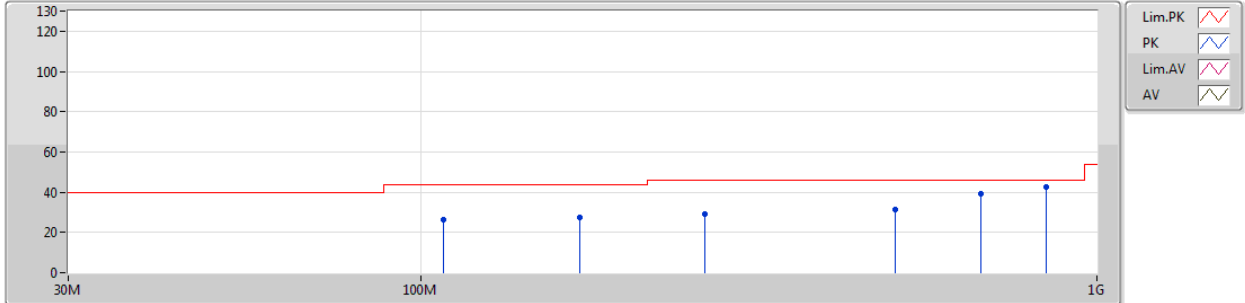

Type	Freq (Hz)	Level (dBuV/m)	Limit (dBuV/m)	Margin (dB)	Factor (dB)	Dist (m)	Condition	Azimuth (°)	Height (m)	Comments
PK	107.6M	26.55	43.50	-16.95	-9.47	3	Horizontal	360	1.00	-
PK	171.62M	27.49	43.50	-16.01	-10.80	3	Horizontal	360	1.00	-
PK	262.8M	29.16	46.00	-16.84	-5.85	3	Horizontal	360	1.00	-
PK	503.36M	31.61	46.00	-14.39	-2.37	3	Horizontal	360	1.00	-
PK	672.14M	39.27	46.00	-6.73	-0.28	3	Horizontal	360	1.00	-
PK	840.92M	42.31	46.00	-3.69	1.73	3	Horizontal	360	1.00	-



BT-LE(1Mbps)

2440MHz_USB

04/03/2019

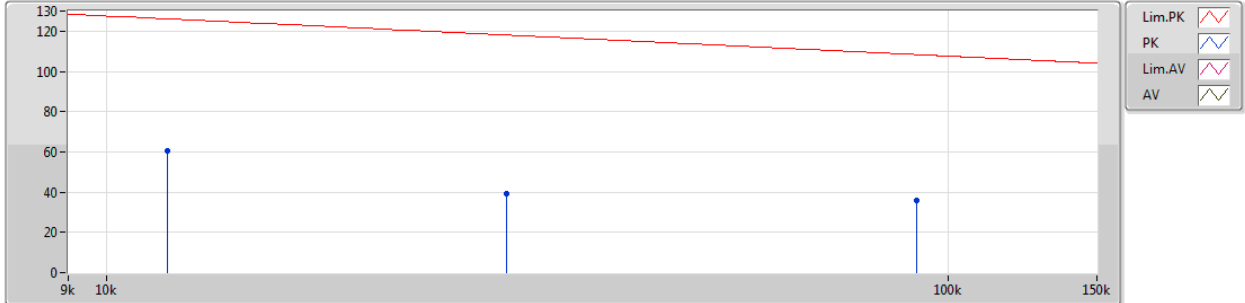

Type	Freq (Hz)	Level (dBuV/m)	Factor (dB)	Dist (m)	Condition	Azimuth (°)	Height (m)	Comments
PK	11.82k	60.78	21.87	3	Horizontal	0	1.00	-
PK	29.868k	39.48	22.07	3	Horizontal	0	1.00	-
PK	91.626k	35.86	20.85	3	Horizontal	0	1.00	-

Frequency (kHz)	Level (dBuV/m)	Level (dBuV/m)	limit (dBuV/m)	Margin
11.82	60.78 @ 3 m	-19.22 @ 300m	46.15	-65.37
29.868	39.48 @ 3 m	-40.52 @ 300m	38.10	-78.62
91.626	35.86 @ 3 m	-44.14 @ 300m	28.36	-72.50

BT-LE(1Mbps)

2440MHz_USB

04/03/2019

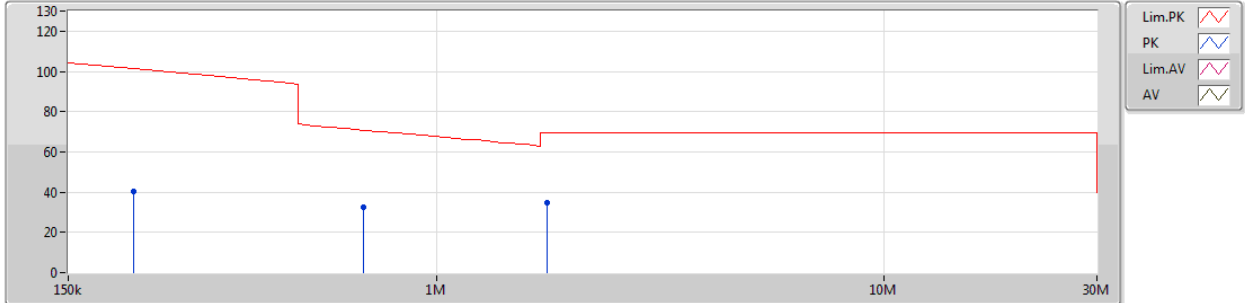

Type	Freq (Hz)	Level (dBuV/m)	Factor (dB)	Dist (m)	Condition	Azimuth (°)	Height (m)	Comments
PK	209.7k	40.60	20.70	3	Horizontal	360	1.00	-
PK	687.3k	32.77	20.62	3	Horizontal	360	1.00	-
PK	1.762M	34.89	20.95	3	Horizontal	360	1.00	-

Frequency (kHz)	Level (dBuV/m)	Level (dBuV/m)	limit (dBuV/m)	Margin
209.7	40.60 @ 3 m	-39.40 @ 300m	21.17	-60.57
687.3	32.77 @ 3 m	-7.23 @ 30m	30.86	-38.09
1762	34.89 @ 3 m	-5.11 @ 30m	29.54	-34.65



BT-LE(1Mbps)

2440MHz_USB

22/01/2019

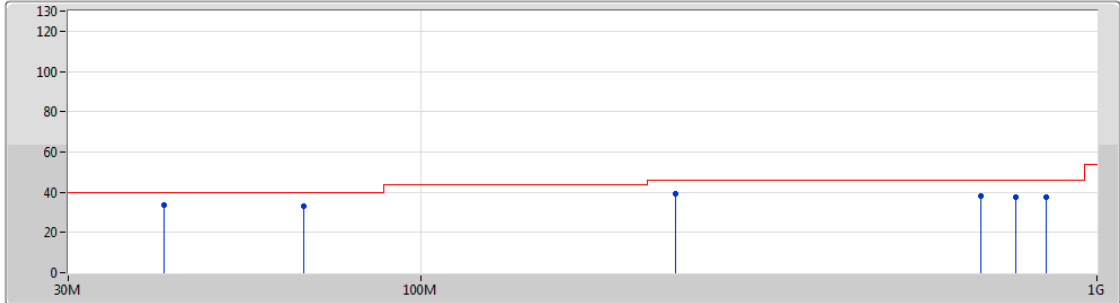

Type	Freq (Hz)	Level (dBuV/m)	Limit (dBuV/m)	Margin (dB)	Factor (dB)	Dist (m)	Condition	Azimuth (°)	Height (m)	Comments
PK	41.64M	33.67	40.00	-6.33	-10.45	3	Vertical	0	1.00	-
PK	66.86M	32.97	40.00	-7.03	-15.49	3	Vertical	0	1.00	-
PK	237.58M	38.95	46.00	-7.05	-8.46	3	Vertical	0	1.00	-
PK	672.14M	38.28	46.00	-7.72	-0.28	3	Vertical	0	1.00	-
PK	757.5M	37.56	46.00	-8.44	1.00	3	Vertical	0	1.00	-
PK	840.92M	37.63	46.00	-8.37	1.73	3	Vertical	0	1.00	-



BT-LE(1Mbps)

2440MHz_USB

22/01/2019

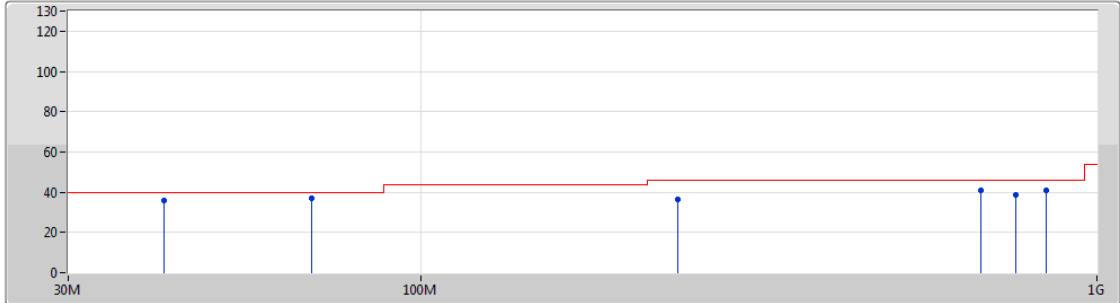

Type	Freq (Hz)	Level (dBuV/m)	Limit (dBuV/m)	Margin (dB)	Factor (dB)	Dist (m)	Condition	Azimuth (°)	Height (m)	Comments
PK	41.64M	36.08	40.00	-3.92	-10.45	3	Horizontal	360	1.00	-
PK	68.8M	36.87	40.00	-3.13	-15.37	3	Horizontal	360	1.00	-
PK	672.14M	41.02	46.00	-4.98	-0.28	3	Horizontal	360	1.00	-
PK	757.5M	38.90	46.00	-7.10	1.00	3	Horizontal	360	1.00	-
PK	840.92M	40.77	46.00	-5.23	1.73	3	Horizontal	360	1.00	-
QP	239.52M	36.56	46.00	-9.44	-8.23	3	Horizontal	228	1.29	-



Summary

Mode	Result	Type	Freq (Hz)	Level (dBuV/m)	Limit (dBuV/m)	Margin (dB)	Factor (dB)	Dist (m)	Condition	Azimuth (°)	Height (m)	Comments
2.4-2.4835GHz	-	-	-	-	-	-	-	-	-	-	-	-
BT-LE(1Mbps)	Pass	AV	2.4835G	49.46	54.00	-4.54	32.29	3	Horizontal	344	2.99	-



Result





Mode	Result	Type	Freq (Hz)	Level (dBuV/m)	Limit (dBuV/m)	Margin (dB)	Factor (dB)	Dist (m)	Condition	Azimuth (°)	Height (m)	Comments
BT-LE(1Mbps)	-	-	-	-	-	-	-	-	-	-	-	-
2402MHz	Pass	AV	2.365G	45.18	54.00	-8.82	31.92	3	Vertical	144	1.18	-
2402MHz	Pass	AV	2.402G	94.80	Inf	-Inf	32.04	3	Vertical	144	1.18	-
2402MHz	Pass	PK	2.3624G	56.71	74.00	-17.29	31.91	3	Vertical	144	1.18	-
2402MHz	Pass	PK	2.4022G	96.14	Inf	-Inf	32.05	3	Vertical	144	1.18	-
2402MHz	Pass	AV	2.3554G	45.14	54.00	-8.86	31.89	3	Horizontal	350	2.86	-
2402MHz	Pass	AV	2.402G	99.92	Inf	-Inf	32.04	3	Horizontal	350	2.86	-
2402MHz	Pass	PK	2.3596G	56.28	74.00	-17.72	31.90	3	Horizontal	350	2.86	-
2402MHz	Pass	PK	2.4018G	101.34	Inf	-Inf	32.04	3	Horizontal	350	2.86	-
2402MHz	Pass	AV	4.81108G	33.02	54.00	-20.98	3.45	3	Vertical	52	1.91	-
2402MHz	Pass	PK	4.80862G	45.43	74.00	-28.57	3.45	3	Vertical	52	1.91	-
2402MHz	Pass	AV	4.79182G	32.84	54.00	-21.16	3.41	3	Horizontal	107	1.33	-
2402MHz	Pass	PK	4.7923G	45.87	74.00	-28.13	3.41	3	Horizontal	107	1.33	-
2440MHz	Pass	AV	2.3544G	45.23	54.00	-8.77	31.88	3	Vertical	144	1.13	-
2440MHz	Pass	AV	2.44G	95.37	Inf	-Inf	32.16	3	Vertical	144	1.13	-
2440MHz	Pass	AV	2.4904G	45.23	54.00	-8.77	32.31	3	Vertical	144	1.13	-
2440MHz	Pass	PK	2.3556G	56.11	74.00	-17.89	31.89	3	Vertical	144	1.13	-
2440MHz	Pass	PK	2.4396G	96.77	Inf	-Inf	32.16	3	Vertical	144	1.13	-
2440MHz	Pass	PK	2.4864G	55.94	74.00	-18.06	32.30	3	Vertical	144	1.13	-
2440MHz	Pass	AV	2.3524G	45.12	54.00	-8.88	31.88	3	Horizontal	359	1.02	-
2440MHz	Pass	AV	2.44G	101.21	Inf	-Inf	32.16	3	Horizontal	359	1.02	-
2440MHz	Pass	AV	2.4948G	45.33	54.00	-8.67	32.33	3	Horizontal	359	1.02	-
2440MHz	Pass	PK	2.3724G	56.75	74.00	-17.25	31.94	3	Horizontal	359	1.02	-
2440MHz	Pass	PK	2.44G	102.66	Inf	-Inf	32.16	3	Horizontal	359	1.02	-
2440MHz	Pass	PK	2.4848G	56.63	74.00	-17.37	32.29	3	Horizontal	359	1.02	-
2440MHz	Pass	AV	4.88156G	33.13	54.00	-20.87	3.63	3	Vertical	156	1.02	-
2440MHz	Pass	PK	4.8875G	45.66	74.00	-28.34	3.66	3	Vertical	156	1.02	-
2440MHz	Pass	AV	4.87832G	33.41	54.00	-20.59	3.62	3	Horizontal	179	1.03	-
2440MHz	Pass	PK	4.88498G	45.38	74.00	-28.62	3.64	3	Horizontal	179	1.03	-
2480MHz	Pass	AV	2.48G	100.98	Inf	-Inf	32.28	3	Vertical	358	1.50	-
2480MHz	Pass	AV	2.4835G	49.00	54.00	-5.00	32.29	3	Vertical	358	1.50	-
2480MHz	Pass	PK	2.4802G	102.46	Inf	-Inf	32.28	3	Vertical	358	1.50	-
2480MHz	Pass	PK	2.4835G	57.34	74.00	-16.66	32.29	3	Vertical	358	1.50	-
2480MHz	Pass	AV	2.48G	101.49	Inf	-Inf	32.28	3	Horizontal	344	2.99	-
2480MHz	Pass	AV	2.4835G	49.46	54.00	-4.54	32.29	3	Horizontal	344	2.99	-
2480MHz	Pass	PK	2.4798G	102.89	Inf	-Inf	32.28	3	Horizontal	344	2.99	-
2480MHz	Pass	PK	2.4836G	57.70	74.00	-16.30	32.29	3	Horizontal	344	2.99	-
2480MHz	Pass	AV	4.96426G	34.14	54.00	-19.86	3.85	3	Vertical	324	1.50	-
2480MHz	Pass	PK	4.97014G	47.23	74.00	-26.77	3.86	3	Vertical	324	1.50	-
2480MHz	Pass	AV	4.95868G	33.68	54.00	-20.32	3.83	3	Horizontal	351	1.50	-
2480MHz	Pass	PK	4.9732G	46.30	74.00	-27.70	3.86	3	Horizontal	351	1.50	-

BT-LE(1Mbps)

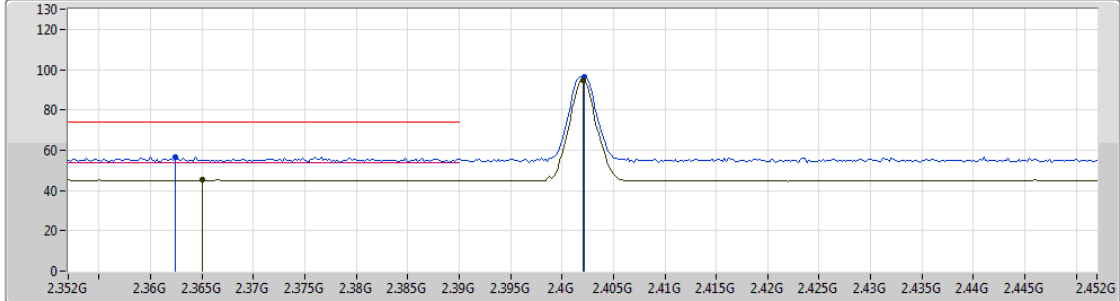
2402MHz_TX

22/01/2019



Lim.PK 
 PK 
 Lim.AV 
 AV 

Type	Freq (Hz)	Level (dBuV/m)	Limit (dBuV/m)	Margin (dB)	Factor (dB)	Dist (m)	Condition	Azimuth (°)	Height (m)	Comments
AV	2.365G	45.18	54.00	-8.82	31.92	3	Vertical	144	1.18	-
AV	2.402G	94.80	Inf	-Inf	32.04	3	Vertical	144	1.18	-
PK	2.3624G	56.71	74.00	-17.29	31.91	3	Vertical	144	1.18	-
PK	2.4022G	96.14	Inf	-Inf	32.05	3	Vertical	144	1.18	-

BT-LE(1Mbps)

2402MHz_TX

22/01/2019

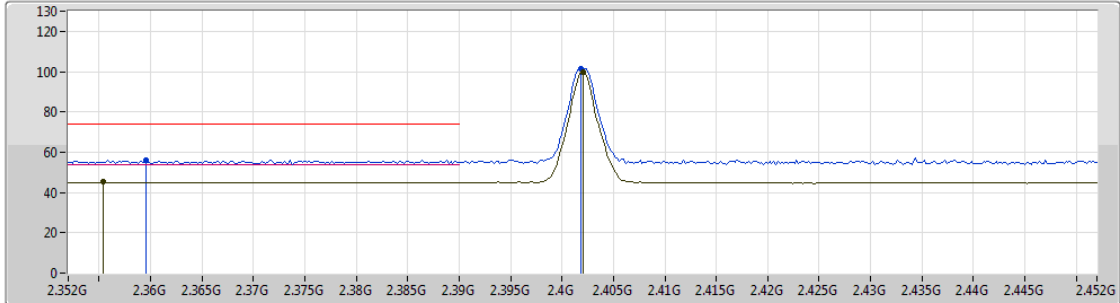





Type	Freq (Hz)	Level (dBuV/m)	Limit (dBuV/m)	Margin (dB)	Factor (dB)	Dist (m)	Condition	Azimuth (°)	Height (m)	Comments
AV	2.3554G	45.14	54.00	-8.86	31.89	3	Horizontal	350	2.86	-
AV	2.402G	99.92	Inf	-Inf	32.04	3	Horizontal	350	2.86	-
PK	2.3596G	56.28	74.00	-17.72	31.90	3	Horizontal	350	2.86	-
PK	2.4018G	101.34	Inf	-Inf	32.04	3	Horizontal	350	2.86	-

BT-LE(1Mbps)

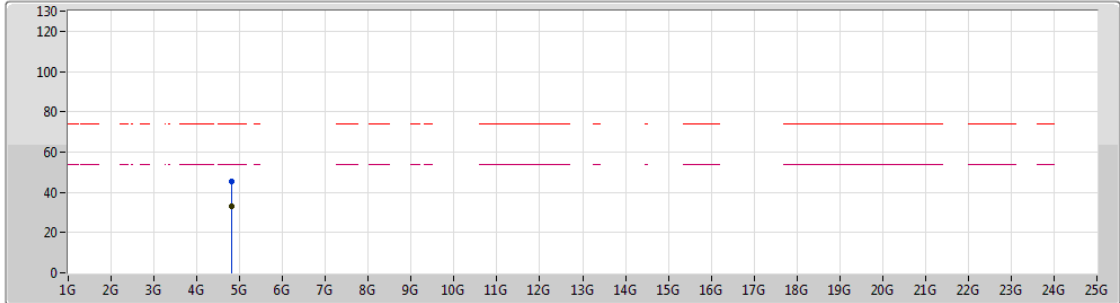
2402MHz_TX

22/01/2019



Lim.PK 
 PK 
 Lim.AV 
 AV 

Type	Freq (Hz)	Level (dBuV/m)	Limit (dBuV/m)	Margin (dB)	Factor (dB)	Dist (m)	Condition	Azimuth (°)	Height (m)	Comments
AV	4.81108G	33.02	54.00	-20.98	3.45	3	Vertical	52	1.91	-
PK	4.80862G	45.43	74.00	-28.57	3.45	3	Vertical	52	1.91	-



BT-LE(1Mbps)

22/01/2019

2402MHz_TX

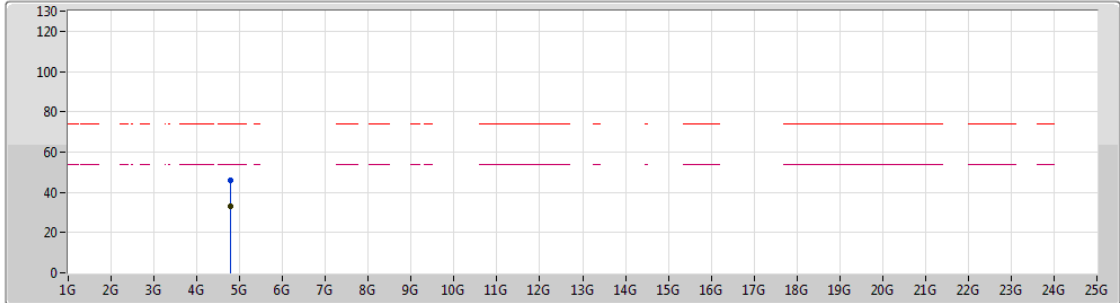

Legend for plot:

- Lim.PK
- PK
- Lim.AV
- AV





Type	Freq (Hz)	Level (dBuV/m)	Limit (dBuV/m)	Margin (dB)	Factor (dB)	Dist (m)	Condition	Azimuth (°)	Height (m)	Comments
AV	4.79182G	32.84	54.00	-21.16	3.41	3	Horizontal	107	1.33	-
PK	4.7923G	45.87	74.00	-28.13	3.41	3	Horizontal	107	1.33	-

BT-LE(1Mbps)

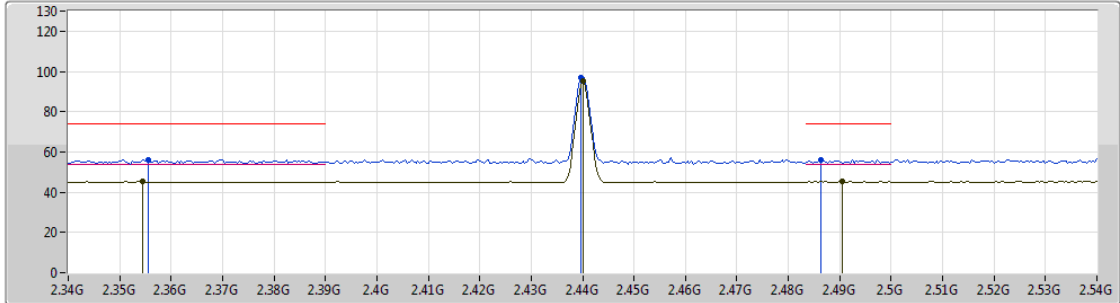
2440MHz_TX

22/01/2019



Lim.PK 
 PK 
 Lim.AV 
 AV 





Type	Freq (Hz)	Level (dBuV/m)	Limit (dBuV/m)	Margin (dB)	Factor (dB)	Dist (m)	Condition	Azimuth (°)	Height (m)	Comments
AV	2.3544G	45.23	54.00	-8.77	31.88	3	Vertical	144	1.13	-
AV	2.44G	95.37	Inf	-Inf	32.16	3	Vertical	144	1.13	-
AV	2.4904G	45.23	54.00	-8.77	32.31	3	Vertical	144	1.13	-
PK	2.3556G	56.11	74.00	-17.89	31.89	3	Vertical	144	1.13	-
PK	2.4396G	96.77	Inf	-Inf	32.16	3	Vertical	144	1.13	-
PK	2.4864G	55.94	74.00	-18.06	32.30	3	Vertical	144	1.13	-

BT-LE(1Mbps)

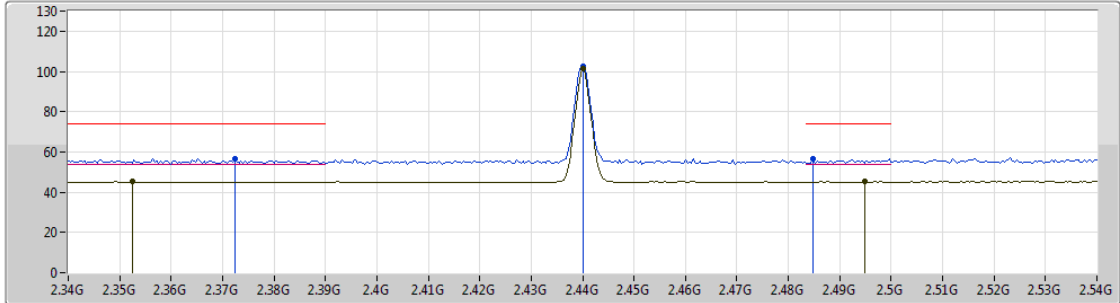
2440MHz_TX

22/01/2019



Lim.PK 
 PK 
 Lim.AV 
 AV 

Type	Freq (Hz)	Level (dBuV/m)	Limit (dBuV/m)	Margin (dB)	Factor (dB)	Dist (m)	Condition	Azimuth (°)	Height (m)	Comments
AV	2.3524G	45.12	54.00	-8.88	31.88	3	Horizontal	359	1.02	-
AV	2.44G	101.21	Inf	-Inf	32.16	3	Horizontal	359	1.02	-
AV	2.4948G	45.33	54.00	-8.67	32.33	3	Horizontal	359	1.02	-
PK	2.3724G	56.75	74.00	-17.25	31.94	3	Horizontal	359	1.02	-
PK	2.44G	102.66	Inf	-Inf	32.16	3	Horizontal	359	1.02	-
PK	2.4848G	56.63	74.00	-17.37	32.29	3	Horizontal	359	1.02	-

BT-LE(1Mbps)

22/01/2019

2440MHz_TX

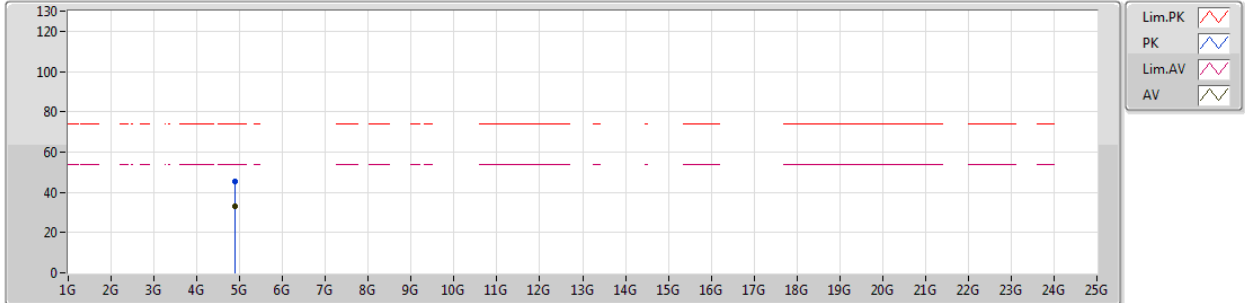

Type	Freq (Hz)	Level (dBuV/m)	Limit (dBuV/m)	Margin (dB)	Factor (dB)	Dist (m)	Condition	Azimuth (°)	Height (m)	Comments
AV	4.88156G	33.13	54.00	-20.87	3.63	3	Vertical	156	1.02	-
PK	4.8875G	45.66	74.00	-28.34	3.66	3	Vertical	156	1.02	-



BT-LE(1Mbps)

22/01/2019

2440MHz_TX

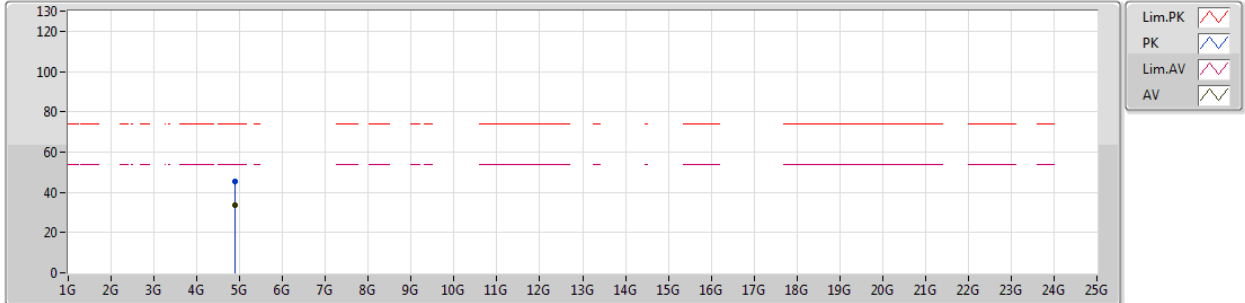





Type	Freq (Hz)	Level (dBuV/m)	Limit (dBuV/m)	Margin (dB)	Factor (dB)	Dist (m)	Condition	Azimuth (°)	Height (m)	Comments
AV	4.87832G	33.41	54.00	-20.59	3.62	3	Horizontal	179	1.03	-
PK	4.88498G	45.38	74.00	-28.62	3.64	3	Horizontal	179	1.03	-

BT-LE(1Mbps)

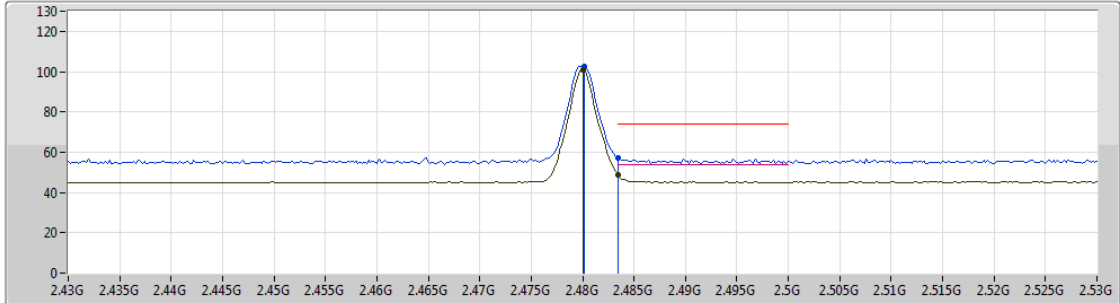
22/01/2019

2480MHz_TX



Lim.PK 
 PK 
 Lim.AV 
 AV 

Type	Freq (Hz)	Level (dBuV/m)	Limit (dBuV/m)	Margin (dB)	Factor (dB)	Dist (m)	Condition	Azimuth (°)	Height (m)	Comments
AV	2.48G	100.98	Inf	-Inf	32.28	3	Vertical	358	1.50	-
AV	2.4835G	49.00	54.00	-5.00	32.29	3	Vertical	358	1.50	-
PK	2.4802G	102.46	Inf	-Inf	32.28	3	Vertical	358	1.50	-
PK	2.4835G	57.34	74.00	-16.66	32.29	3	Vertical	358	1.50	-

BT-LE(1Mbps)

2480MHz_TX

22/01/2019

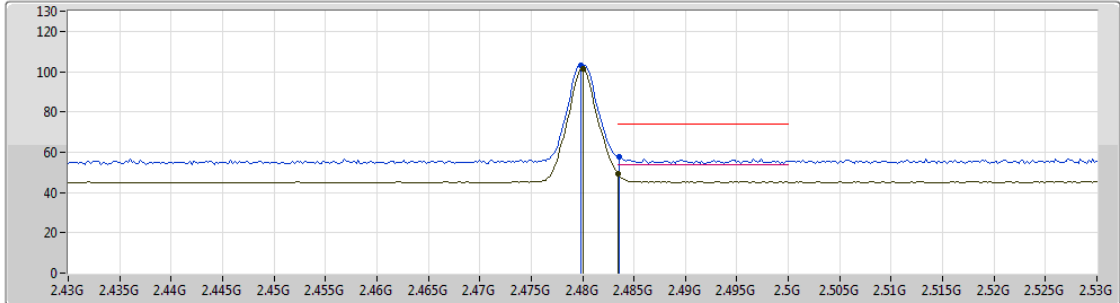

Type	Freq (Hz)	Level (dBuV/m)	Limit (dBuV/m)	Margin (dB)	Factor (dB)	Dist (m)	Condition	Azimuth (°)	Height (m)	Comments
AV	2.48G	101.49	Inf	-Inf	32.28	3	Horizontal	344	2.99	-
AV	2.4835G	49.46	54.00	-4.54	32.29	3	Horizontal	344	2.99	-
PK	2.4798G	102.89	Inf	-Inf	32.28	3	Horizontal	344	2.99	-
PK	2.4836G	57.70	74.00	-16.30	32.29	3	Horizontal	344	2.99	-



BT-LE(1Mbps)

22/01/2019

2480MHz_TX

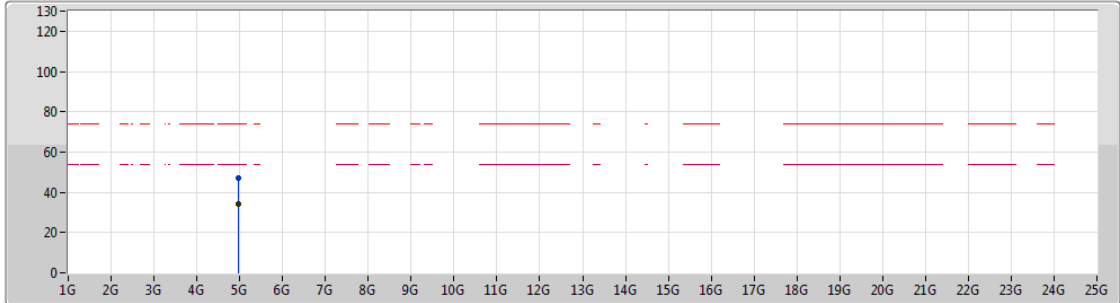

Lim.PK
 PK
 Lim.AV
 AV

Type	Freq (Hz)	Level (dBuV/m)	Limit (dBuV/m)	Margin (dB)	Factor (dB)	Dist (m)	Condition	Azimuth (°)	Height (m)	Comments
AV	4.96426G	34.14	54.00	-19.86	3.85	3	Vertical	324	1.50	-
PK	4.97014G	47.23	74.00	-26.77	3.86	3	Vertical	324	1.50	-



BT-LE(1Mbps)

2480MHz_TX

22/01/2019

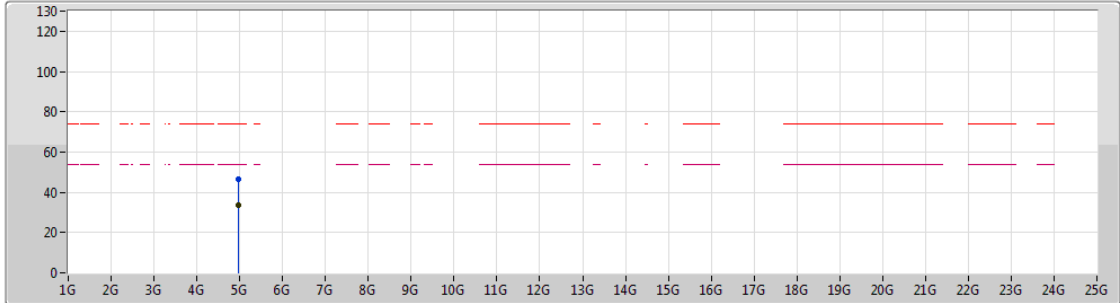

Legend for the plot:

- Lim.PK
- PK
- Lim.AV
- AV

Type	Freq (Hz)	Level (dBuV/m)	Limit (dBuV/m)	Margin (dB)	Factor (dB)	Dist (m)	Condition	Azimuth (°)	Height (m)	Comments
AV	4.95868G	33.68	54.00	-20.32	3.83	3	Horizontal	351	1.50	-
PK	4.9732G	46.30	74.00	-27.70	3.86	3	Horizontal	351	1.50	-