

FCC Test Report

Report No.: RF150127C26K-2

FCC ID: ZQANC111

Test Model: A00005

Series Model: A0005

Received Date: Sep. 27, 2018

Test Date: Jan. 25 ~ Feb. 15, 2019

Issued Date: Feb. 19, 2019

Applicant: Nest Labs Inc.

Address: 3400 Hillview Ave. Palo Alto California, United States 94304

Issued By: Bureau Veritas Consumer Products Services (H.K.) Ltd., Taoyuan Branch

Lab Address: No. 47-2, 14th Ling, Chia Pau Vil., Lin Kou Dist., New Taipei City, Taiwan (R.O.C.)

Test Location: No. 19, Hwa Ya 2nd Rd., Wen Hwa Vil., Kwei Shan Dist., Taoyuan City 33383, TAIWAN (R.O.C.)

**FCC Registration/
Designation Number:** 788550 / TW0003



This report is for your exclusive use. Any copying or replication of this report to or for any other person or entity, or use of our name or trademark, is permitted only with our prior written permission. This report sets forth our findings solely with respect to the test samples identified herein. The results set forth in this report are not indicative or representative of the quality or characteristics of the lot from which a test sample was taken or any similar or identical product specifically and expressly noted. Our report includes all of the tests requested by you and the results thereof based upon the information that you provided to us. You have 60 days from date of issuance of this report to notify us of any material error or omission caused by our negligence, provided, however, that such notice shall be in writing and shall specifically address the issue you wish to raise. A failure to raise such issue within the prescribed time shall constitute your unqualified acceptance of the completeness of this report, the tests conducted and the correctness of the report contents. Unless specific mention, the uncertainty of measurement has been explicitly taken into account to declare the compliance or non-compliance to the specification. The report must not be used by the client to claim product certification, approval, or endorsement by TAF or any government agencies.

Table of Contents

Release Control Record	4
1 Certificate of Conformity	5
2 Summary of Test Results	6
2.1 Measurement Uncertainty	6
2.2 Modification Record	6
3 General Information	7
3.1 General Description of EUT	7
3.2 Description of Test Modes	8
3.2.1 Test Mode Applicability and Tested Channel Detail	10
3.3 Duty Cycle of Test Signal	12
3.4 Description of Support Units	13
3.4.1 Configuration of System under Test	13
3.5 General Description of Applied Standards	13
4 Test Types and Results	14
4.1 Radiated Emission and Bandedge Measurement.....	14
4.1.1 Limits of Radiated Emission and Bandedge Measurement	14
4.1.2 Test Instruments	15
4.1.3 Test Procedures.....	16
4.1.4 Deviation from Test Standard	17
4.1.5 Test Set Up	17
4.1.6 EUT Operating Conditions.....	18
4.1.7 Test Results for Fundamental, Harmonic and Bandedge above 1GHz	19
4.1.8 Test Results for below 1GHz	151
4.2 Conducted Emission Measurement	155
4.2.1 Limits of Conducted Emission Measurement	155
4.2.2 Test Instruments	155
4.2.3 Test Procedures.....	156
4.2.4 Deviation from Test Standard	156
4.2.5 Test Setup.....	156
4.2.6 EUT Operating Conditions.....	156
4.2.7 Test Results	157
4.3 Transmit Power Measurement	161
4.3.1 Limits of Transmit Power Measurement	161
4.3.2 Test Setup.....	161
4.3.3 Test Instruments	161
4.3.4 Test Procedure	162
4.3.5 Deviation from Test Standard	162
4.3.6 EUT Operating Conditions.....	162
4.3.7 Test Result.....	163
4.4 Occupied Bandwidth Measurement	169
4.4.1 Test Setup.....	169
4.4.2 Test Instruments	169
4.4.3 Test Procedure	169
4.4.4 Test Result.....	170
4.5 Peak Power Spectral Density Measurement	172
4.5.1 Limits of Peak Power Spectral Density Measurement	172
4.5.2 Test Setup.....	172
4.5.3 Test Instruments	172
4.5.4 Test Procedures.....	173
4.5.5 Deviation from Test Standard	173
4.5.6 EUT Operating Conditions.....	173
4.5.7 Test Results	174
4.6 Frequency Stability.....	178

4.6.1	Limits of Frequency Stability Measurement	178
4.6.2	Test Setup.....	178
4.6.3	Test Instruments	178
4.6.4	Test Procedure	178
4.6.5	Deviation from Test Standard	179
4.6.6	EUT Operating Condition	179
4.6.7	Test Results	179
4.7	6dB Bandwidth Measurement.....	180
4.7.1	Limits of 6dB Bandwidth Measurement.....	180
4.7.2	Test Setup.....	180
4.7.3	Test Instruments	180
4.7.4	Test Procedure	180
4.7.5	Deviation from Test Standard	180
4.7.6	EUT Operating Condition	180
4.7.7	Test Results	181
5	Pictures of Test Arrangements.....	183
	Appendix – Information of the Testing Laboratories	184

Release Control Record

Issue No.	Description	Date Issued
RF150127C26K-2	Original release.	Feb. 19, 2019

1 Certificate of Conformity

Product: Wireless Camera
Test Model: A00005
Series Model: A0005
Sample Status: Identical Prototype
Applicant: Nest Labs Inc.
Test Date: Jan. 25 ~ Feb. 15, 2019
Standards: 47 CFR FCC Part 15, Subpart E (Section 15.407)
ANSI C63.10:2013

The above equipment has been tested by **Bureau Veritas Consumer Products Services (H.K.) Ltd., Taoyuan Branch**, and found compliance with the requirement of the above standards. The test record, data evaluation & Equipment Under Test (EUT) configurations represented herein are true and accurate accounts of the measurements of the sample's RF characteristics under the conditions specified in this report.

Prepared by : Pettie Chen , **Date:** Feb. 19, 2019
Pettie Chen / Senior Specialist

Approved by : Bruce Chen , **Date:** Feb. 19, 2019
Bruce Chen / Project Engineer

2 Summary of Test Results

47 CFR FCC Part 15, Subpart E (Section 15.407)			
FCC Clause	Test Item	Result	Remarks
15.407(b)(6)	AC Power Conducted Emissions	Pass	Meet the requirement of limit. Minimum passing margin is -7.12dB at 0.61875MHz.
15.407(b) (1/2/3/4(i/ii)/6)	Radiated Emissions & Band Edge Measurement	Pass	Meet the requirement of limit. Minimum passing margin is -3.0dB at 10600.00, 10440.00, 11650.00MHz.
15.407(a)(1/2/3)	Max Average Transmit Power	Pass	Meet the requirement of limit.
---	Occupied Bandwidth Measurement	Pass	Meet the requirement of limit.
15.407(a)(1/2/3)	Peak Power Spectral Density	Pass	Meet the requirement of limit. (U-NII-3 Band only)
15.407(e)	6dB bandwidth	Pass	Meet the requirement of limit.
15.407(g)	Frequency Stability	Pass	Meet the requirement of limit.
15.203	Antenna Requirement	Pass	No antenna connector is used.

*For U-NII-3 band compliance with rule part 15.407(b)(4)(i), the OOB test plots were recorded in Annex A.
 Note: Determining compliance based on the results of the compliance measurement, not taking into account measurement instrumentation uncertainty.

2.1 Measurement Uncertainty

Where relevant, the following measurement uncertainty levels have been estimated for tests performed on the EUT as specified in CISPR 16-4-2:

Measurement	Frequency	Expanded Uncertainty (k=2) (±)
Conducted Emissions at mains ports	150kHz ~ 30MHz	2.94 dB
Radiated Emissions up to 1 GHz	30MHz ~ 200MHz	3.86 dB
	200MHz ~ 1000MHz	3.87 dB
Radiated Emissions above 1 GHz	1GHz ~ 18GHz	2.29 dB
	18GHz ~ 40GHz	2.29 dB

2.2 Modification Record

There were no modifications required for compliance.

3 General Information

3.1 General Description of EUT

Product	Wireless Camera
Test Model	A00005
Series Model	A0005
Model Difference	Refer to Note
Sample Status	Identical Prototype
Power Supply Rating	4.75~5.25Vdc
Modulation Type	64QAM, 16QAM, QPSK, BPSK
Modulation Technology	OFDM
Transfer Rate	802.11a: 54/48/36/24/18/12/9/6Mbps 802.11n: up to MCS7
Operating Frequency	5180~5240MHz, 5260~5320MHz, 5500~5700MHz, 5745~5825MHz
Number of Channel	5180 ~ 5240MHz: 802.11a, 802.11n (HT20): 4 802.11n (HT40) 2 5260 ~ 5320MHz: 802.11a, 802.11n (HT20): 4 802.11n (HT40): 2 5500 ~ 5700MHz: 802.11a, 802.11n (HT20): 11 802.11n (HT40): 5 5745 ~ 5825MHz: 802.11a, 802.11n (HT20): 5 802.11n (HT40): 2
Output Power	5180~5240MHz: 20.606mW 5260~5320MHz: 25.763mW 5500~5700MHz: 56.624mW 5745~5825MHz: 32.285mW
Antenna Type	Integral antenna with -1.5dBi gain
Antenna Connector	NA
Accessory Device	NA
Data Cable Supplied	NA

Note:

1. All models are listed as below. Model: A00005 is the representative for final test.

Model	Difference
A00005	For marketing purposes only
A0005	

2. The EUT provides 1 completed transmitter and 1 receiver.

Modulation Mode	TX Function
802.11a	1TX
802.11n (HT20)	1TX
802.11n (HT40)	1TX

3.2 Description of Test Modes

For 5180~5240MHz:

4 channels are provided for 802.11a, 802.11n (HT20):

Channel	Frequency	Channel	Frequency
36	5180MHz	44	5220MHz
40	5200MHz	48	5240MHz

2 channels are provided for 802.11n (HT40):

Channel	Frequency	Channel	Frequency
38	5190MHz	46	5230MHz

For 5260~5320MHz:

4 channels are provided for 802.11a, 802.11n (HT20):

Channel	Frequency	Channel	Frequency
52	5260MHz	60	5300MHz
56	5280MHz	64	5320MHz

2 channels are provided for 802.11n (HT40):

Channel	Frequency	Channel	Frequency
54	5270MHz	62	5310MHz

For 5500~5700MHz:

11 channels are provided for 802.11a, 802.11n (HT20):

Channel	Frequency	Channel	Frequency
100	5500MHz	124	5620MHz
104	5520MHz	128	5640MHz
108	5540MHz	132	5660MHz
112	5560MHz	136	5680MHz
116	5580MHz	140	5700MHz
120	5600MHz		

5 channels are provided for 802.11n (HT40):

Channel	Frequency	Channel	Frequency
102	5510MHz	126	5630MHz
110	5550MHz	134	5670MHz
118	5590MHz		

For 5745~5825MHz:

5 channels are provided for 802.11a, 802.11n (HT20):

Channel	Frequency	Channel	Frequency
149	5745MHz	161	5805MHz
153	5765MHz	165	5825MHz
157	5785MHz		

2 channels are provided for 802.11n (HT40):

Channel	Frequency	Channel	Frequency
151	5755MHz	159	5795MHz

3.2.1 Test Mode Applicability and Tested Channel Detail

EUT Configure Mode	Applicable to				Description
	RE \geq 1G	RE<1G	PLC	APCM	
A	√	√	√	√	Power from host
B	-	√	√	-	Power from adapter

Where RE \geq 1G: Radiated Emission above 1GHz & Bandedge Measurement
 RE<1G: Radiated Emission below 1GHz
 PLC: Power Line Conducted Emission
 APCM: Antenna Port Conducted Measurement

Note:

1. The EUT had been pre-tested on the positioned of each 3 axis. The worst case was found when positioned on **Y-plane**.

Radiated Emission Test (Above 1GHz):

- Pre-Scan has been conducted to determine the worst-case mode from all possible combinations between available modulations, data rates and antenna ports (if EUT with antenna diversity architecture).
- Following channel(s) was (were) selected for the final test as listed below.

EUT Configure Mode	Mode	Frequency Band (MHz)	Available Channel	Tested Channel	Modulation Technology	Data Rate (Mbps)
A	802.11a	5180-5240	36 to 48	36, 44, 48	OFDM	6.0
	802.11n (HT20)		36 to 48	36, 44, 48	OFDM	MCS0
	802.11n (HT40)		38 to 46	38, 46	OFDM	MCS0
A	802.11a	5260-5320	52 to 64	52, 60, 64	OFDM	6.0
	802.11n (HT20)		52 to 64	52, 60, 64	OFDM	MCS0
	802.11n (HT40)		54 to 62	54, 62	OFDM	MCS0
A	802.11a	5500-5700	100 to 140	100, 116, 140	OFDM	6.0
	802.11n (HT20)		100 to 140	100, 116, 140	OFDM	MCS0
	802.11n (HT40)		102 to 134	102, 110, 134	OFDM	MCS0
A	802.11a	5745-5825	149 to 165	149, 157, 165	OFDM	6.0
	802.11n (HT20)		149 to 165	149, 157, 165	OFDM	MCS0
	802.11n (HT40)		151 to 159	151, 159	OFDM	MCS0

Radiated Emission Test (Below 1GHz):

- Pre-Scan has been conducted to determine the worst-case mode from all possible combinations between available modulations, data rates and antenna ports (if EUT with antenna diversity architecture).
- Following channel(s) was (were) selected for the final test as listed below.

EUT Configure Mode	Mode	Frequency Band (MHz)	Available Channel	Tested Channel	Modulation Technology	Data Rate (Mbps)
A, B	802.11a	5180-5240	36 to 48	116	OFDM	6.0
		5260-5320	52 to 64		OFDM	6.0
		5500-5700	100 to 140		OFDM	6.0
		5745-5825	149 to 165		OFDM	6.0

Power Line Conducted Emission Test:

- Pre-Scan has been conducted to determine the worst-case mode from all possible combinations between available modulations, data rates and antenna ports (if EUT with antenna diversity architecture).
- Following channel(s) was (were) selected for the final test as listed below.

EUT Configure Mode	Mode	Frequency Band (MHz)	Available Channel	Tested Channel	Modulation Technology	Data Rate (Mbps)
A, B	802.11a	5180-5240	36 to 48	116	OFDM	6.0
		5260-5320	52 to 64		OFDM	6.0
		5500-5700	100 to 140		OFDM	6.0
		5745-5825	149 to 165		OFDM	6.0

Antenna Port Conducted Measurement:

- This item includes all test value of each mode, but only includes spectrum plot of worst value of each mode.
- Pre-Scan has been conducted to determine the worst-case mode from all possible combinations between available modulations, data rates and antenna ports (if EUT with antenna diversity architecture).
- Following channel(s) was (were) selected for the final test as listed below.

EUT Configure Mode	Mode	Frequency Band (MHz)	Available Channel	Tested Channel	Modulation Technology	Data Rate (Mbps)
A	802.11a	5180-5240	36 to 48	36, 44, 48	OFDM	6.0
	802.11n (HT20)		36 to 48	36, 44, 48	OFDM	MCS0
	802.11n (HT40)		38 to 46	38, 46	OFDM	MCS0
A	802.11a	5260-5320	52 to 64	52, 60, 64	OFDM	6.0
	802.11n (HT20)		52 to 64	52, 60, 64	OFDM	MCS0
	802.11n (HT40)		54 to 62	54, 62	OFDM	MCS0
A	802.11a	5500-5700	100 to 140	100, 116, 140	OFDM	6.0
	802.11n (HT20)		100 to 140	100, 116, 140	OFDM	MCS0
	802.11n (HT40)		102 to 134	102, 110, 134	OFDM	MCS0
A	802.11a	5745-5825	149 to 165	149, 157, 165	OFDM	6.0
	802.11n (HT20)		149 to 165	149, 157, 165	OFDM	MCS0
	802.11n (HT40)		151 to 159	151, 159	OFDM	MCS0

Test Condition:

Applicable to	Environmental Conditions	Input Power	Tested by
RE \geq 1G	21 deg. C, 69% RH 22 deg. C, 66% RH	120Vac, 60Hz	Willy Cheng Adair Peng
RE<1G	24 deg. C, 65% RH	120Vac, 60Hz	Adair Peng
PLC	24 deg. C, 65% RH	120Vac, 60Hz	Willy Cheng
APCM	25 deg. C, 60% RH	120Vac, 60Hz	Alan Wu

3.3 Duty Cycle of Test Signal

Duty cycle of test signal is $\geq 98\%$, duty factor is not required.

Duty cycle of test signal is $< 98\%$, duty factor shall be considered.

802.11a: Duty cycle = $2.06/2.10 = 0.981$

802.11n (HT20): Duty cycle = $1.91/1.952 = 0.978$, Duty factor = $10 * \log(1/0.978) = 0.09$

802.11n (HT40): Duty cycle = $0.938/0.981 = 0.956$, Duty factor = $10 * \log(1/0.956) = 0.19$

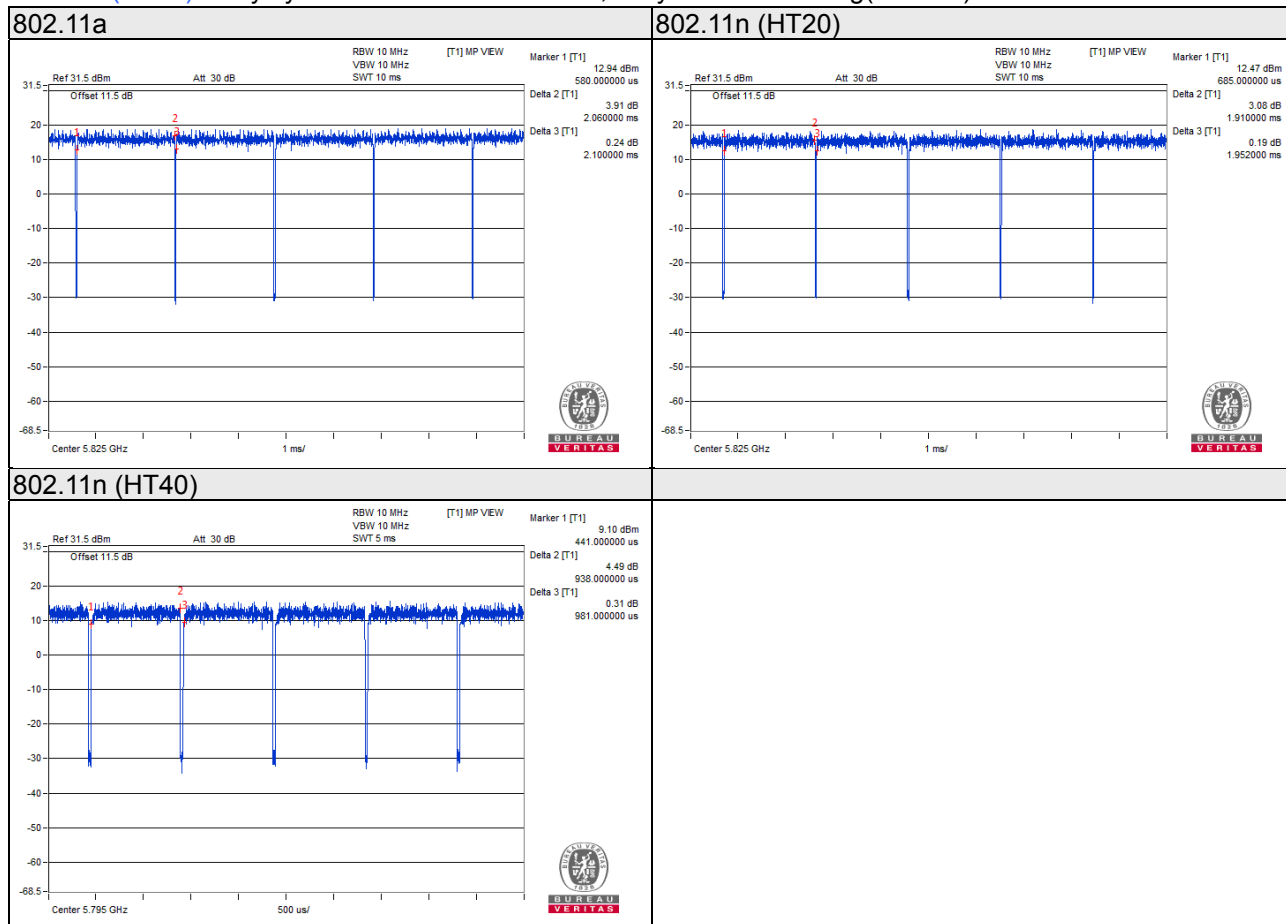

3.4 Description of Support Units

The EUT has been tested as an independent unit together with other necessary accessories or support units. The following support units or accessories were used to form a representative test configuration during the tests.

ID	Product	Brand	Model No.	Serial No.	FCC ID	Remarks
A.	Notebook	DELL	E5420	BPQ8MQ1	FCC DoC Approved	-
B.	AC Adapter	Nest	A0018	NA	NA	I/P: 100 - 240 Vac, 0.2 A, O/P: 5 Vdc, 1.4A Provided by client

Note:

1. All power cords of the above support units are non-shielded (1.8m).

ID	Descriptions	Qty.	Length (m)	Shielding (Yes/No)	Cores (Qty.)	Remarks
1.	USB cable	1	2	Y	0	-

3.4.1 Configuration of System under Test

Test Mode A



Test Mode B



3.5 General Description of Applied Standards

The EUT is a RF Product. According to the specifications of the manufacturer, it must comply with the requirements of the following standards:

FCC Part 15, Subpart E (15.407)

KDB 789033 D02 General UNII Test Procedure New Rules v02r01

ANSI C63.10:2013

All test items have been performed and recorded as per the above standards.

4 Test Types and Results

4.1 Radiated Emission and Bandedge Measurement

4.1.1 Limits of Radiated Emission and Bandedge Measurement

Radiated emissions which fall in the restricted bands must comply with the radiated emission limits specified as below table.

Frequencies (MHz)	Field Strength (microvolts/meter)	Measurement Distance (meters)
0.009 ~ 0.490	2400/F(kHz)	300
0.490 ~ 1.705	24000/F(kHz)	30
1.705 ~ 30.0	30	30
30 ~ 88	100	3
88 ~ 216	150	3
216 ~ 960	200	3
Above 960	500	3

NOTE:

1. The lower limit shall apply at the transition frequencies.
2. Emission level (dBuV/m) = 20 log Emission level (uV/m).
3. For frequencies above 1000MHz, the field strength limits are based on average detector, however, the peak field strength of any emission shall not exceed the maximum permitted average limits, specified above by more than 20dB under any condition of modulation.

Limits of unwanted emission out of the restricted bands

Applicable To		Limit	
789033 D02 General UNII Test Procedure New Rules v02r01		Field Strength at 3m	
		PK: 74 (dBµV/m)	AV: 54 (dBµV/m)
Frequency Band	Applicable To	EIRP Limit	Equivalent Field Strength at 3m
5150~5250 MHz	15.407(b)(1)	PK: -27 (dBm/MHz)	PK: 68.2(dBµV/m)
5250~5350 MHz	15.407(b)(2)		
5470~5725 MHz	15.407(b)(3)		
5725~5850 MHz	<input checked="" type="checkbox"/> 15.407(b)(4)(i)	PK: -27 (dBm/MHz) ^{*1} PK: 10 (dBm/MHz) ^{*2} PK: 15.6 (dBm/MHz) ^{*3} PK: 27 (dBm/MHz) ^{*4}	PK: 68.2(dBµV/m) ^{*1} PK: 105.2 (dBµV/m) ^{*2} PK: 110.8(dBµV/m) ^{*3} PK: 122.2 (dBµV/m) ^{*4}
	<input type="checkbox"/> 15.407(b)(4)(ii)	Emission limits in section 15.247(d)	
^{*1} beyond 75 MHz or more above of the band edge. ^{*3} below the band edge increasing linearly to a level of 15.6 dBm/MHz at 5 MHz above.		^{*2} below the band edge increasing linearly to 10 dBm/MHz at 25 MHz above. ^{*4} from 5 MHz above or below the band edge increasing linearly to a level of 27 dBm/MHz at the band edge.	

Note: The following formula is used to convert the equipment isotropic radiated power (eirp) to field strength:

$$E = \frac{1000000 \sqrt{30P}}{3} \mu\text{V/m, where P is the eirp (Watts).}$$

4.1.2 Test Instruments

Description & Manufacturer	Model No.	Serial No.	Cal. Date	Cal. Due
Test Receiver ROHDE & SCHWARZ	ESIB7	100187	May 29, 2018	May 28, 2019
Spectrum Analyzer ROHDE & SCHWARZ	FSP40	100040	Sep. 25, 2018	Sep. 24, 2019
BILOG Antenna SCHWARZBECK	VULB9168	9168-171	Nov. 22, 2018	Nov. 21, 2019
HORN Antenna SCHWARZBECK	9120D	209	Nov. 25, 2018	Nov. 24, 2019
HORN Antenna SCHWARZBECK	BBHA 9170	BBHA9170241	Nov. 25, 2018	Nov. 24, 2019
Preamplifier Agilent (Below 1GHz)	8447D	2944A10738	Aug. 21, 2018	Aug. 20, 2019
Preamplifier Agilent (Above 1GHz)	8449B	3008A02465	Apr. 03, 2018	Apr. 02, 2019
RF signal cable HUBER+SUHNER	SUCOFLEX 104	Cable-CH3-03 (223653/4)	Aug. 21, 2018	Aug. 20, 2019
RF signal cable HUBER+SUHNER& EMCI	SUCOFLEX 104&EMC104-SM-SM- 8000	Cable-CH3-03 (309224+170907)	Aug. 21, 2018	Aug. 20, 2019
Software BV ADT	ADT_Radiated_ V7.6.15.9.5	NA	NA	NA
Antenna Tower inn-co GmbH	MA 4000	013303	NA	NA
Antenna Tower Controller BV ADT	AT100	AT93021702	NA	NA
Turn Table BV ADT	TT100	TT93021702	NA	NA
Turn Table Controller BV ADT	SC100	SC93021702	NA	NA
Boresight Antenna Fixture	FBA-01	FBA-SIP01	NA	NA
USB Wideband Power Sensor KEYSIGHT	U2021XA	MY55050005/MY55190 004/MY55190007/MY55 210005	Jul. 17, 2018	Jul. 16, 2019
Pre-amplifier (18GHz-40GHz) EMC	EMC184045B	980175	Nov. 14, 2018	Nov. 13, 2019

- Note:
1. The calibration interval of the above test instruments is 12 months and the calibrations are traceable to NML/ROC and NIST/USA.
 2. The test was performed in HwaYa Chamber 3.
 3. The horn antenna and preamplifier (model: 8449B) are used only for the measurement of emission frequency above 1GHz if tested.
 4. The FCC Designation Number is TW0003. The number will be varied with the Lab location and scope as attached.
 5. The IC Site Registration No. is 7450F-3.

4.1.3 Test Procedures

For Radiated emission below 30MHz

- a. The EUT was placed on the top of a rotating table 0.8 meters above the ground at a 3 meter chamber room. The table was rotated 360 degrees to determine the position of the highest radiation.
- b. The EUT was set 3 meters away from the interference-receiving antenna, which was mounted on the top of a variable-height antenna tower.
- c. Parallel, perpendicular, and ground-parallel orientations of the antenna are set to make the measurement.
- d. For each suspected emission, the EUT was arranged to its worst case and the rotatable table was turned from 0 degrees to 360 degrees to find the maximum reading.
- e. The test-receiver system was set to Quasi-Peak Detect Function and Specified Bandwidth with Maximum Hold Mode.

Note:

1. The resolution bandwidth and video bandwidth of test receiver/spectrum analyzer is 9kHz at frequency below 30MHz.

For Radiated emission above 30MHz

- a. The EUT was placed on the top of a rotating table 0.8 meters (for 30MHz ~ 1GHz) / 1.5 meters (for above 1GHz) above the ground at 3 meter chamber room for test. The table was rotated 360 degrees to determine the position of the highest radiation.
- b. The EUT was set 3 meters away from the interference-receiving antenna, which was mounted on the top of a variable-height antenna tower.
- c. The height of antenna is varied from one meter to four meters above the ground to determine the maximum value of the field strength. Both horizontal and vertical polarizations of the antenna are set to make the measurement.
- d. For each suspected emission, the EUT was arranged to its worst case and then the antenna was tuned to heights from 1 meter to 4 meters and the rotatable table was turned from 0 degrees to 360 degrees to find the maximum reading.
- e. The test-receiver system was set to quasi-peak detect function and specified bandwidth with maximum hold mode when the test frequency is below 1 GHz.
- f. The test-receiver system was set to peak and average detect function and specified bandwidth with maximum hold mode when the test frequency is above 1 GHz. If the peak reading value also meets average limit, measurement with the average detector is unnecessary.

Note:

1. The resolution bandwidth and video bandwidth of test receiver/spectrum analyzer is 120kHz for Quasi-peak detection (QP) at frequency below 1GHz.
2. The resolution bandwidth of test receiver/spectrum analyzer is 1 MHz and the video bandwidth is 3 MHz for Peak detection (PK) at frequency above 1GHz.
3. The resolution bandwidth of test receiver/spectrum analyzer is 1MHz and the video bandwidth is $\geq 1/T$ (Duty cycle < 98%) or 10Hz (Duty cycle $\geq 98\%$) for Average detection (AV) at frequency above 1GHz.
4. All modes of operation were investigated and the worst-case emissions are reported.

4.1.4 Deviation from Test Standard

No deviation.

4.1.5 Test Set Up

For Radiated emission below 30MHz

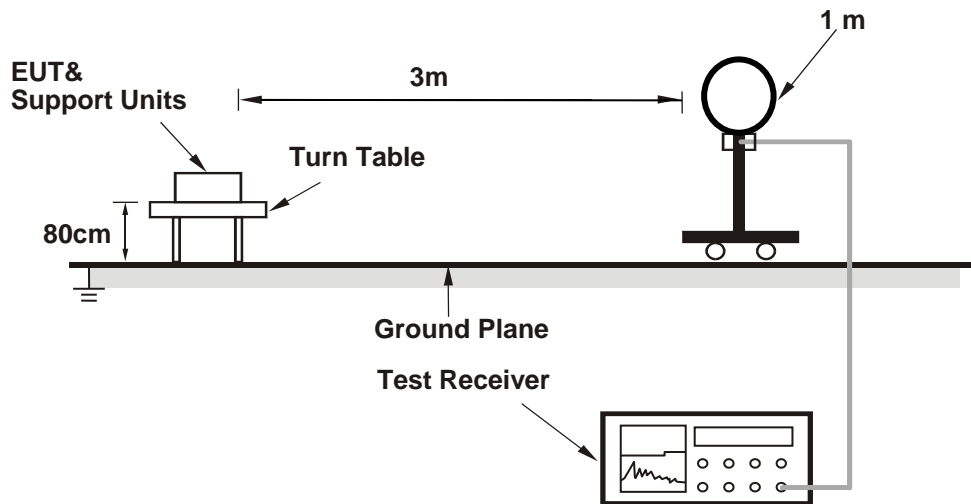

For Radiated emission 30MHz to 1GHz

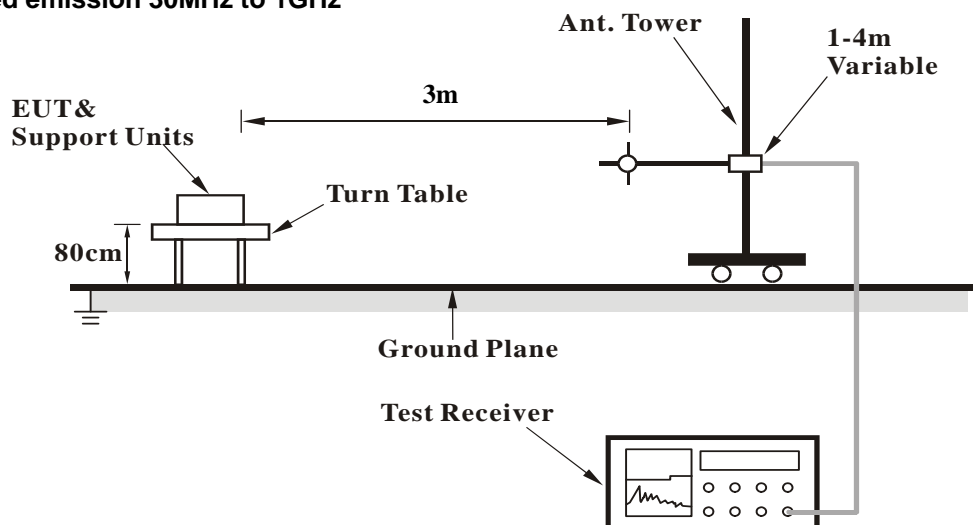

For Radiated emission above 1GHz

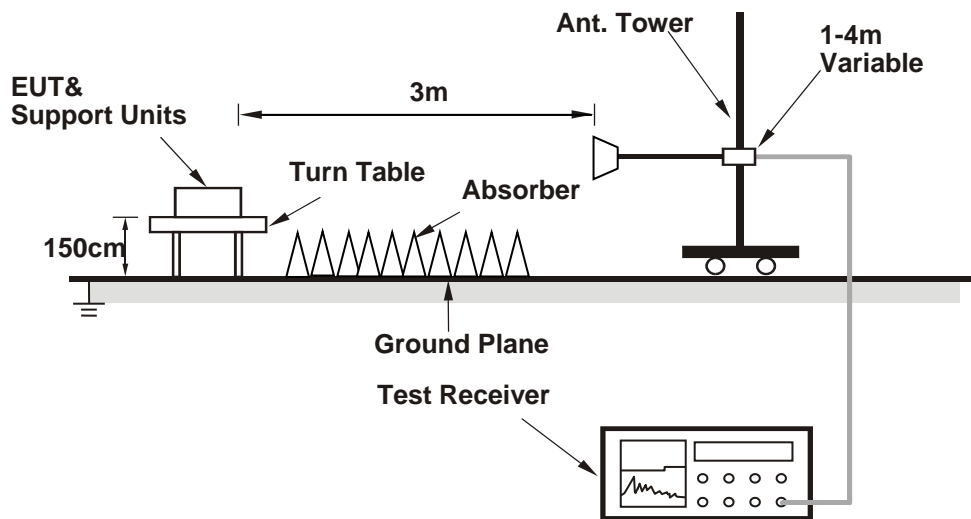

For the actual test configuration, please refer to the attached file (Test Setup Photo).

Test Mode	Duty Cycle (%)	RBW (PK)	VBW (PK)	RBW (Avg)	VBW (Avg)
802.11a	98.1	1MHz	3MHz	1MHz	10Hz
802.11n(HT20)	97.8	1MHz	3MHz	1MHz	1kHz
802.11n(HT40)	95.6	1MHz	3MHz	1MHz	3kHz

4.1.6 EUT Operating Conditions

- a. Set the EUT under transmission condition continuously at specific channel frequency.

4.1.7 Test Results for Fundamental, Harmonic and Bandedge above 1GHz

802.11a

CHANNEL	TX Channel 36	DETECTOR FUNCTION	Peak (PK)
FREQUENCY RANGE	1GHz ~ 40GHz		Average (AV)

ANTENNA POLARITY & TEST DISTANCE: HORIZONTAL AT 3 M								
NO.	FREQ. (MHz)	EMISSION LEVEL (dBuV/m)	LIMIT (dBuV/m)	MARGIN (dB)	ANTENNA HEIGHT (m)	TABLE ANGLE (Degree)	RAW VALUE (dBuV)	CORRECTION FACTOR (dB/m)
1	5150.00	54.9 PK	74.0	-19.1	1.17 H	293	51.0	3.9
2	5150.00	41.6 AV	54.0	-12.4	1.17 H	293	37.7	3.9
3	*5180.00	97.5 PK			1.07 H	279	58.0	39.5
4	*5180.00	87.2 AV			1.07 H	279	47.7	39.5
5	#10360.00	64.2 PK	68.2	-4.0	1.09 H	262	48.4	15.8

Remarks:

1. Emission Level(dBuV/m) = Raw Value(dBuV) + Correction Factor(dB/m)
2. Correction Factor(dB/m) = Antenna Factor(dB/m) + Cable Factor(dB) – Pre-Amplifier Factor(dB)
3. The other emission levels were very low against the limit
4. Margin value = Emission Level – Limit value
5. " * ": Fundamental frequency
6. " # ": The radiated frequency is out of the restricted band.

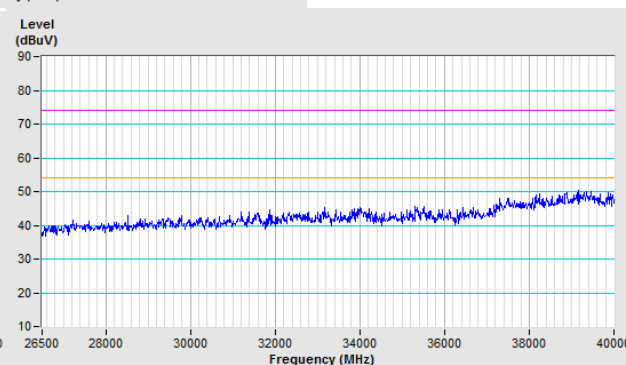
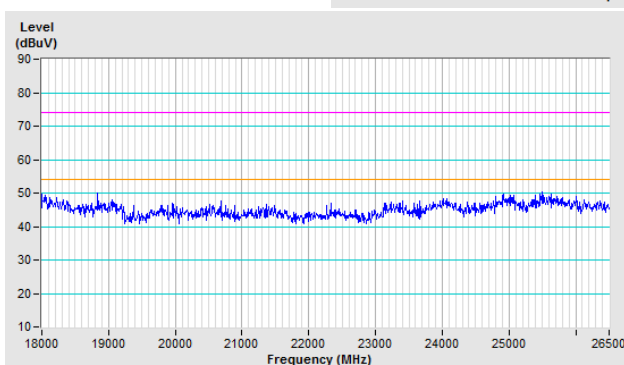
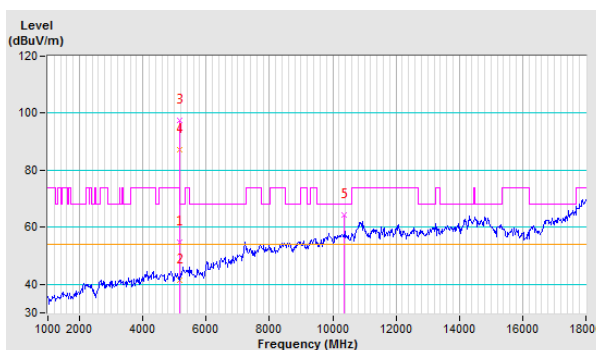

For Bandedge

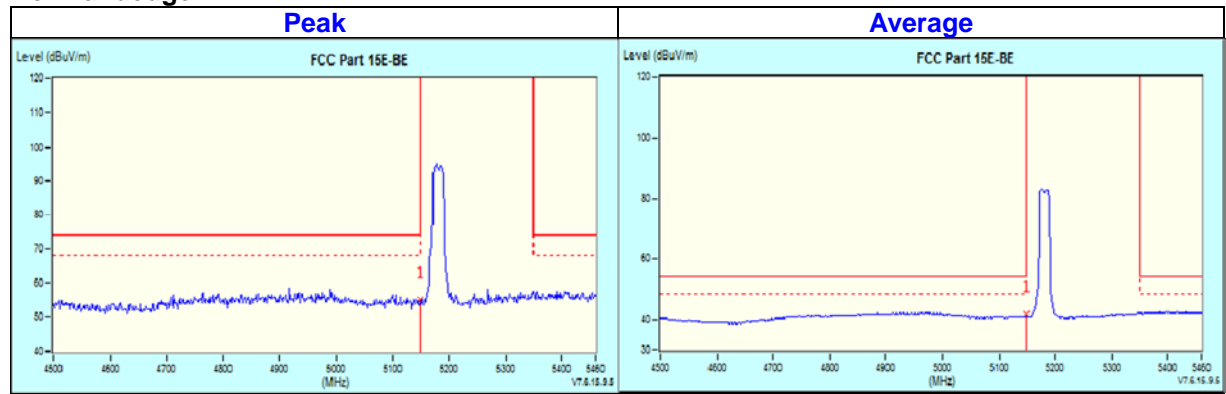

CHANNEL	TX Channel 36	DETECTOR FUNCTION	Peak (PK) Average (AV)
FREQUENCY RANGE	1GHz ~ 40GHz		

ANTENNA POLARITY & TEST DISTANCE: VERTICAL AT 3 M								
NO.	FREQ. (MHz)	EMISSION LEVEL (dBuV/m)	LIMIT (dBuV/m)	MARGIN (dB)	ANTENNA HEIGHT (m)	TABLE ANGLE (Degree)	RAW VALUE (dBuV)	CORRECTION FACTOR (dB/m)
1	5150.00	55.9 PK	74.0	-18.1	1.30 V	40	52.0	3.9
2	5150.00	42.5 AV	54.0	-11.5	1.30 V	40	38.6	3.9
3	*5180.00	102.4 PK			1.21 V	39	62.9	39.5
4	*5180.00	92.5 AV			1.21 V	39	53.0	39.5
5	#10360.00	65.0 PK	68.2	-3.2	1.70 V	12	49.2	15.8

Remarks:

1. Emission Level(dBuV/m) = Raw Value(dBuV) + Correction Factor(dB/m)
2. Correction Factor(dB/m) = Antenna Factor(dB/m) + Cable Factor(dB) – Pre-Amplifier Factor(dB)
3. The other emission levels were very low against the limit
4. Margin value = Emission Level – Limit value
5. " * ": Fundamental frequency
6. " # ": The radiated frequency is out of the restricted band.

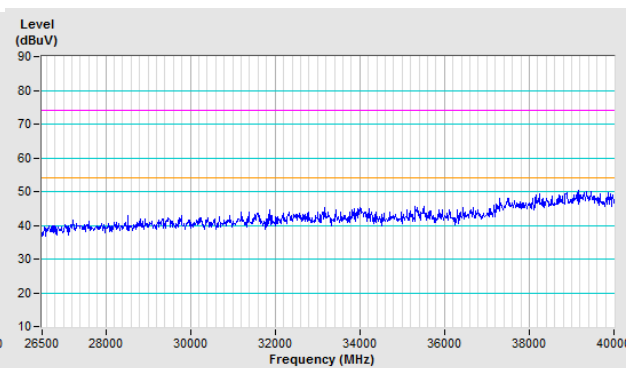
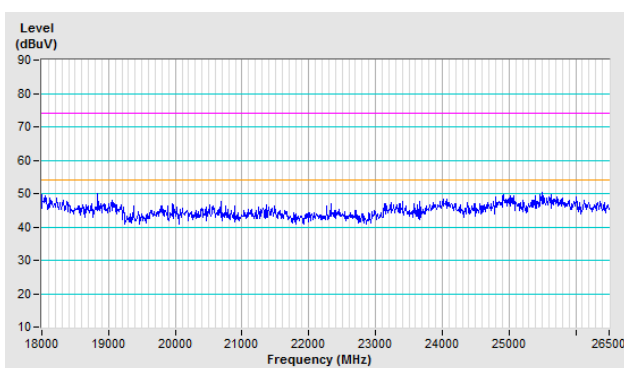
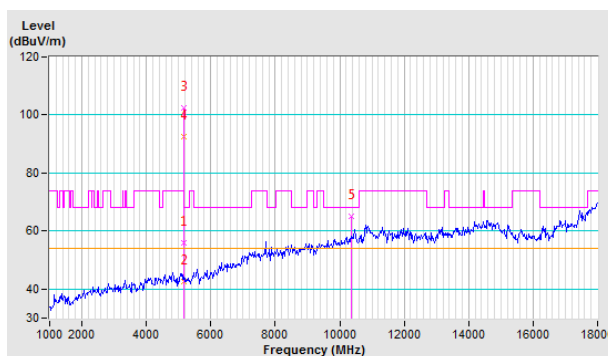

For Bandedge

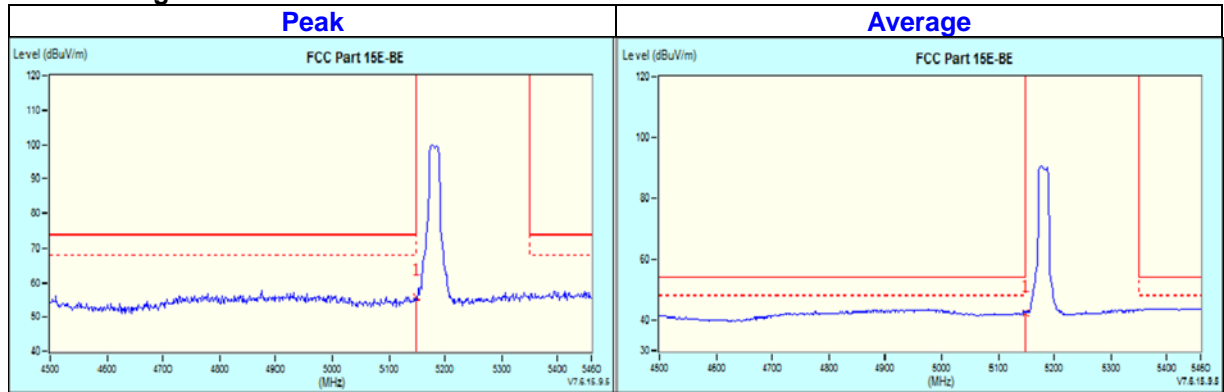

CHANNEL	TX Channel 44	DETECTOR FUNCTION	Peak (PK)
FREQUENCY RANGE	1GHz ~ 40GHz		Average (AV)

ANTENNA POLARITY & TEST DISTANCE: HORIZONTAL AT 3 M								
NO.	FREQ. (MHz)	EMISSION LEVEL (dBuV/m)	LIMIT (dBuV/m)	MARGIN (dB)	ANTENNA HEIGHT (m)	TABLE ANGLE (Degree)	RAW VALUE (dBuV)	CORRECTION FACTOR (dB/m)
1	5150.00	58.9 PK	74.0	-15.1	1.22 H	280	55.0	3.9
2	5150.00	43.6 AV	54.0	-10.4	1.22 H	280	39.7	3.9
3	*5220.00	97.5 PK			1.17 H	276	58.1	39.4
4	*5220.00	87.4 AV			1.17 H	276	48.0	39.4
5	#10440.00	64.5 PK	68.2	-3.7	1.11 H	263	48.0	16.5

Remarks:

1. Emission Level(dBuV/m) = Raw Value(dBuV) + Correction Factor(dB/m)
2. Correction Factor(dB/m) = Antenna Factor(dB/m) + Cable Factor(dB) – Pre-Amplifier Factor(dB)
3. The other emission levels were very low against the limit
4. Margin value = Emission Level – Limit value
5. " * ": Fundamental frequency
6. " # ": The radiated frequency is out of the restricted band.

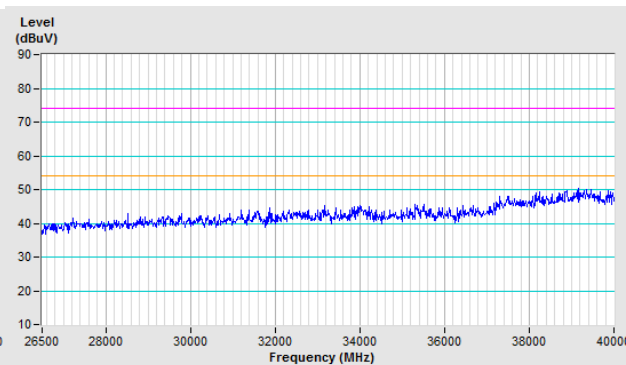
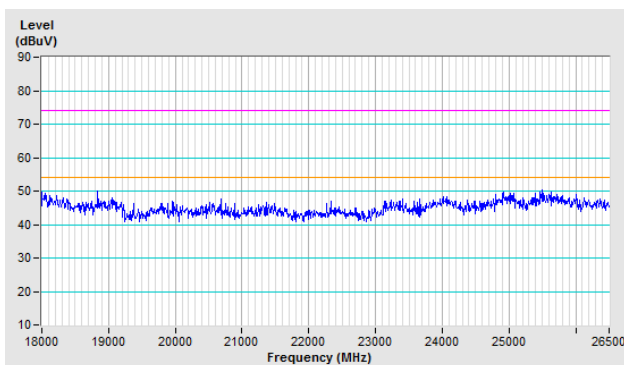
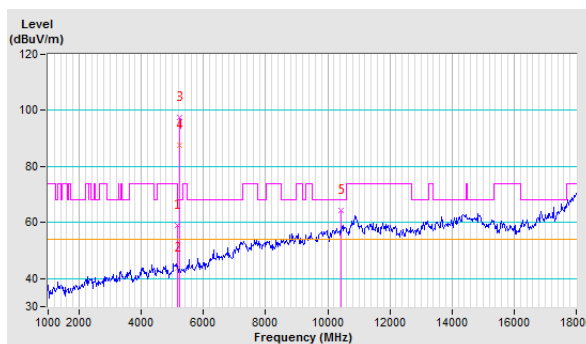

For Bandedge

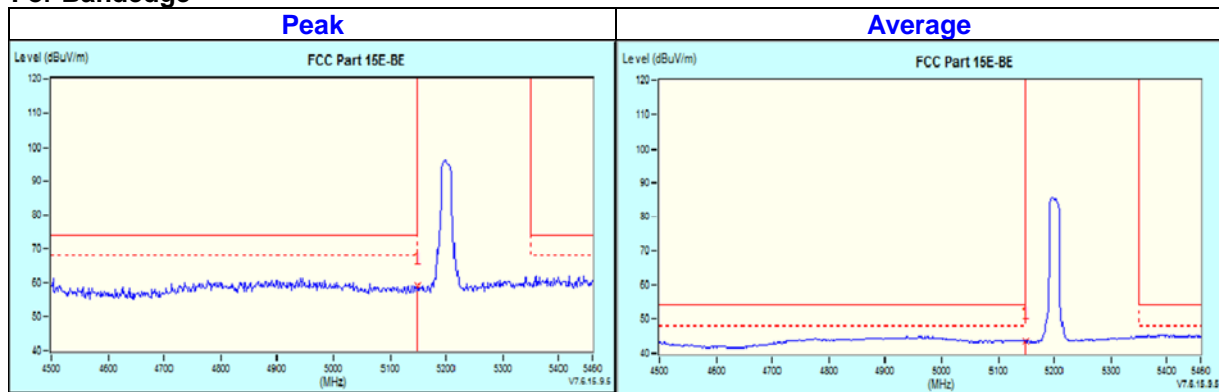

CHANNEL	TX Channel 44	DETECTOR FUNCTION	Peak (PK) Average (AV)
FREQUENCY RANGE	1GHz ~ 40GHz		

ANTENNA POLARITY & TEST DISTANCE: VERTICAL AT 3 M								
NO.	FREQ. (MHz)	EMISSION LEVEL (dBuV/m)	LIMIT (dBuV/m)	MARGIN (dB)	ANTENNA HEIGHT (m)	TABLE ANGLE (Degree)	RAW VALUE (dBuV)	CORRECTION FACTOR (dB/m)
1	5150.00	55.6 PK	74.0	-18.4	1.11 V	60	51.7	3.9
2	5150.00	43.6 AV	54.0	-10.4	1.11 V	60	39.7	3.9
3	*5220.00	102.5 PK			1.04 V	41	63.1	39.4
4	*5220.00	92.4 AV			1.04 V	41	53.0	39.4
5	#10440.00	65.2 PK	68.2	-3.0	2.10 V	13	48.7	16.5

Remarks:

1. Emission Level(dBuV/m) = Raw Value(dBuV) + Correction Factor(dB/m)
2. Correction Factor(dB/m) = Antenna Factor(dB/m) + Cable Factor(dB) – Pre-Amplifier Factor(dB)
3. The other emission levels were very low against the limit
4. Margin value = Emission Level – Limit value
5. " * ": Fundamental frequency
6. " # ": The radiated frequency is out of the restricted band.

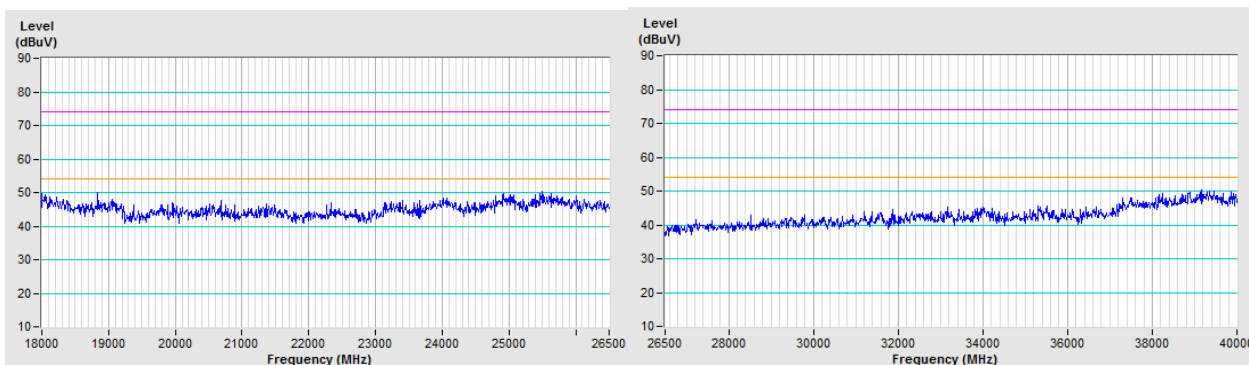
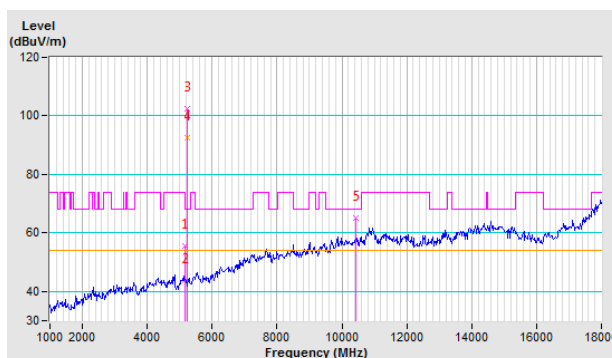

For Bandedge

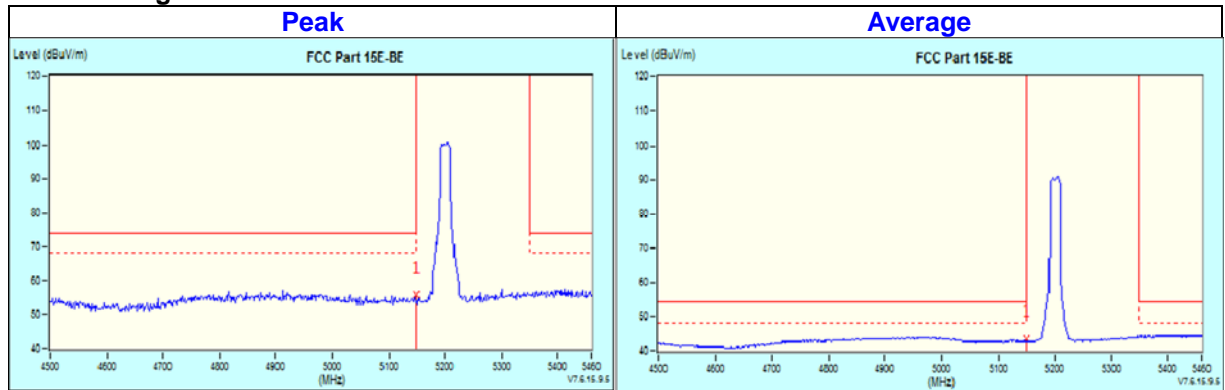

CHANNEL	TX Channel 48	DETECTOR FUNCTION	Peak (PK)
FREQUENCY RANGE	1GHz ~ 40GHz		Average (AV)

ANTENNA POLARITY & TEST DISTANCE: HORIZONTAL AT 3 M								
NO.	FREQ. (MHz)	EMISSION LEVEL (dBuV/m)	LIMIT (dBuV/m)	MARGIN (dB)	ANTENNA HEIGHT (m)	TABLE ANGLE (Degree)	RAW VALUE (dBuV)	CORRECTION FACTOR (dB/m)
1	*5240.00	94.0 PK			1.09 H	280	54.7	39.3
2	*5240.00	84.0 AV			1.09 H	280	44.7	39.3
3	5350.00	57.6 PK	74.0	-16.4	1.19 H	301	53.7	3.9
4	5350.00	42.9 AV	54.0	-11.1	1.19 H	301	39.0	3.9
5	#10480.00	63.5 PK	68.2	-4.7	1.38 H	350	46.7	16.8

Remarks:

1. Emission Level(dBuV/m) = Raw Value(dBuV) + Correction Factor(dB/m)
2. Correction Factor(dB/m) = Antenna Factor(dB/m) + Cable Factor(dB) – Pre-Amplifier Factor(dB)
3. The other emission levels were very low against the limit
4. Margin value = Emission Level – Limit value
5. " * ": Fundamental frequency
6. " # ": The radiated frequency is out of the restricted band.

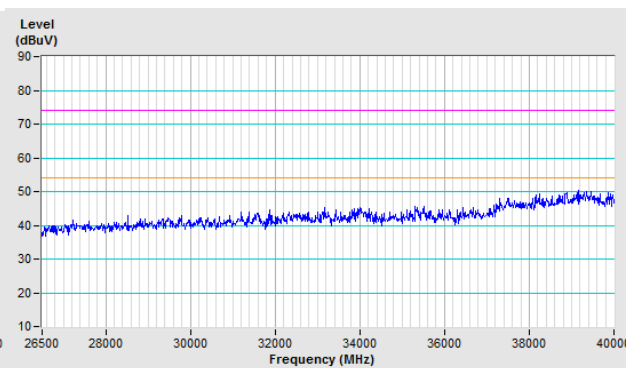
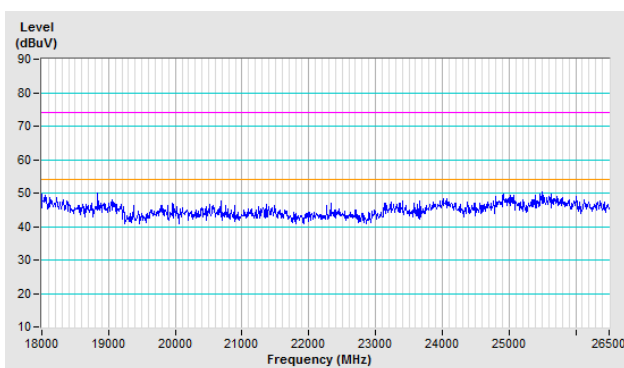
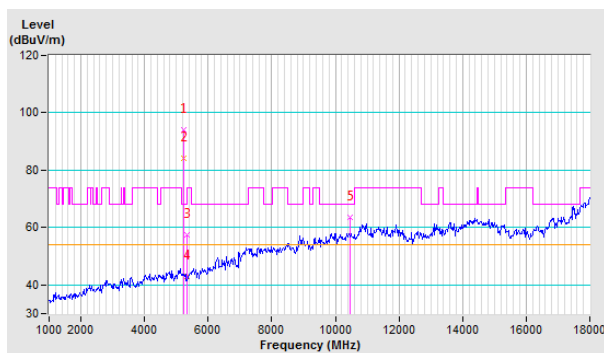

For Bandedge

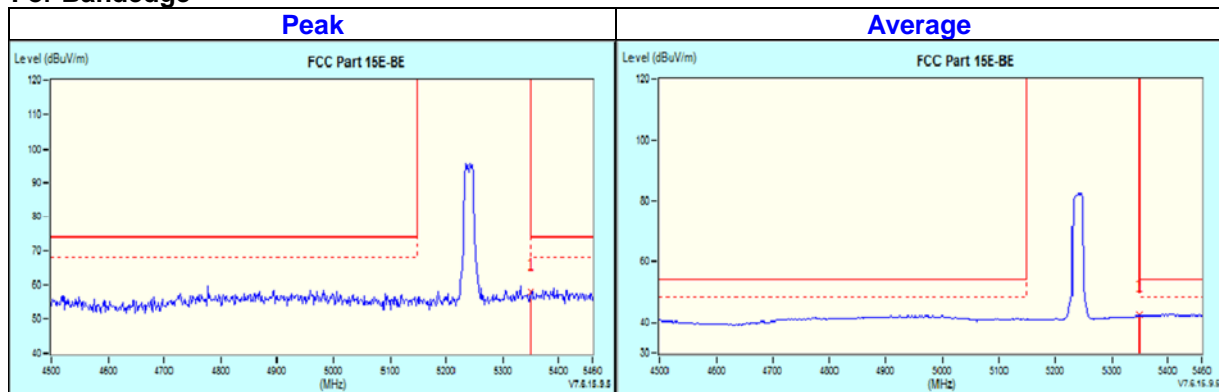

CHANNEL	TX Channel 48	DETECTOR FUNCTION	Peak (PK) Average (AV)
FREQUENCY RANGE	1GHz ~ 40GHz		

ANTENNA POLARITY & TEST DISTANCE: VERTICAL AT 3 M								
NO.	FREQ. (MHz)	EMISSION LEVEL (dBuV/m)	LIMIT (dBuV/m)	MARGIN (dB)	ANTENNA HEIGHT (m)	TABLE ANGLE (Degree)	RAW VALUE (dBuV)	CORRECTION FACTOR (dB/m)
1	*5240.00	101.3 PK			1.04 V	35	62.0	39.3
2	*5240.00	91.7 AV			1.04 V	35	52.4	39.3
3	5350.00	55.9 PK	74.0	-18.1	1.28 V	24	52.0	3.9
4	5350.00	43.1 AV	54.0	-10.9	1.28 V	24	39.2	3.9
5	#10480.00	64.8 PK	68.2	-3.4	2.30 V	9	48.0	16.8

Remarks:

1. Emission Level(dBuV/m) = Raw Value(dBuV) + Correction Factor(dB/m)
2. Correction Factor(dB/m) = Antenna Factor(dB/m) + Cable Factor(dB) – Pre-Amplifier Factor(dB)
3. The other emission levels were very low against the limit
4. Margin value = Emission Level – Limit value
5. " * ": Fundamental frequency
6. " # ": The radiated frequency is out of the restricted band.

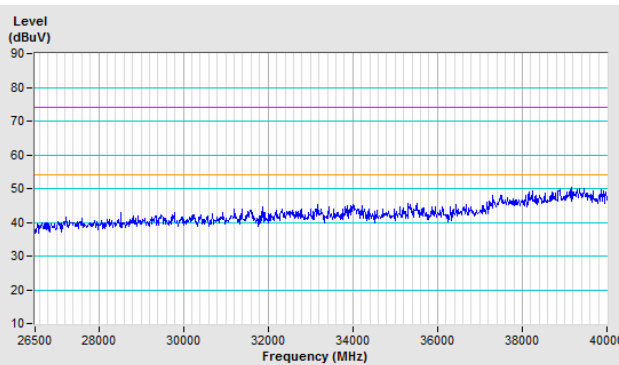
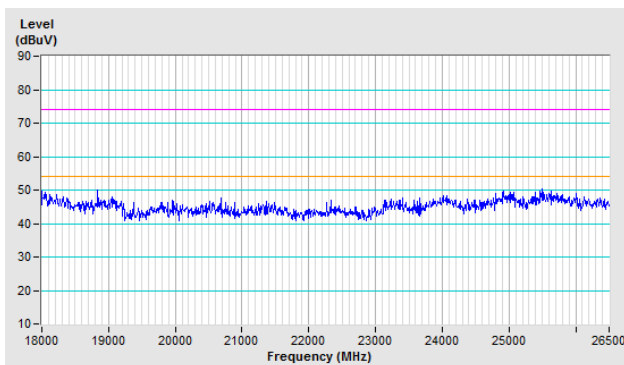
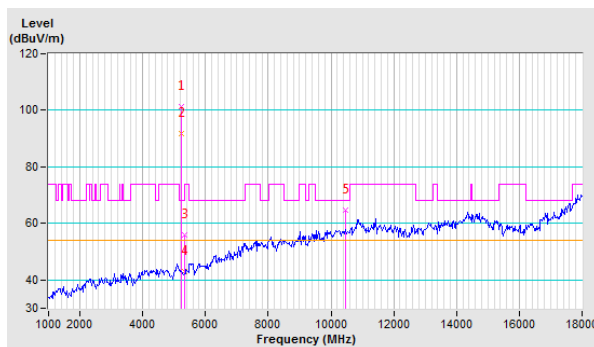

For Bandedge

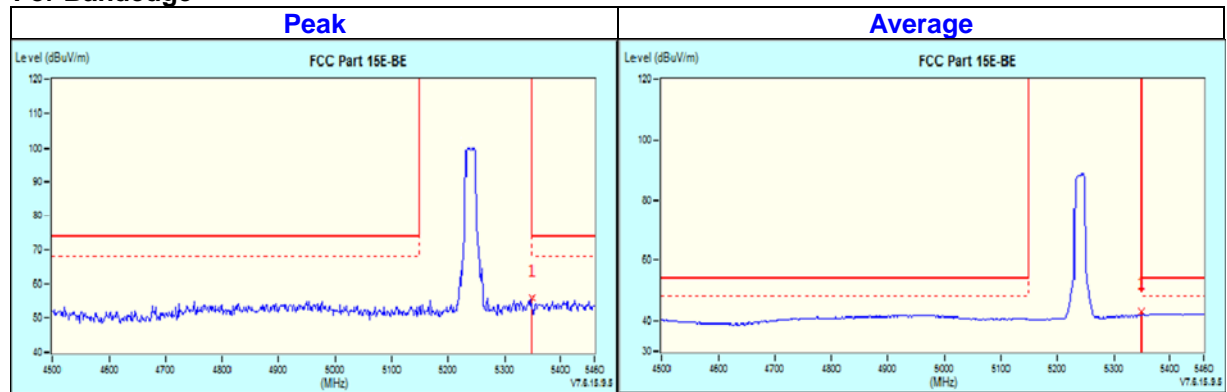

CHANNEL	TX Channel 52	DETECTOR FUNCTION	Peak (PK)
FREQUENCY RANGE	1GHz ~ 40GHz		Average (AV)

ANTENNA POLARITY & TEST DISTANCE: HORIZONTAL AT 3 M								
NO.	FREQ. (MHz)	EMISSION LEVEL (dBuV/m)	LIMIT (dBuV/m)	MARGIN (dB)	ANTENNA HEIGHT (m)	TABLE ANGLE (Degree)	RAW VALUE (dBuV)	CORRECTION FACTOR (dB/m)
1	5150.00	56.0 PK	74.0	-18.0	3.26 H	311	52.1	3.9
2	5150.00	43.2 AV	54.0	-10.8	3.26 H	311	39.3	3.9
3	*5260.00	98.2 PK			3.53 H	337	58.9	39.3
4	*5260.00	87.9 AV			3.53 H	337	48.6	39.3
5	#10520.00	63.6 PK	68.2	-4.6	1.06 H	54	46.7	16.9

Remarks:

1. Emission Level(dBuV/m) = Raw Value(dBuV) + Correction Factor(dB/m)
2. Correction Factor(dB/m) = Antenna Factor(dB/m) + Cable Factor(dB) – Pre-Amplifier Factor(dB)
3. The other emission levels were very low against the limit
4. Margin value = Emission Level – Limit value
5. " * ": Fundamental frequency
6. " # ": The radiated frequency is out of the restricted band.

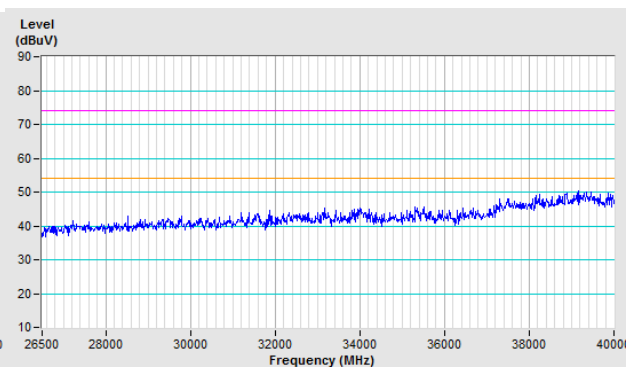
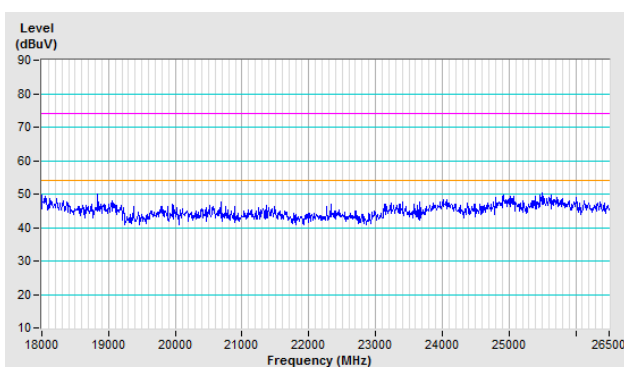
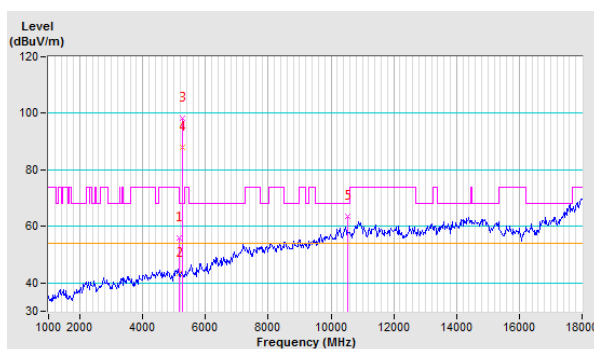

For Bandedge

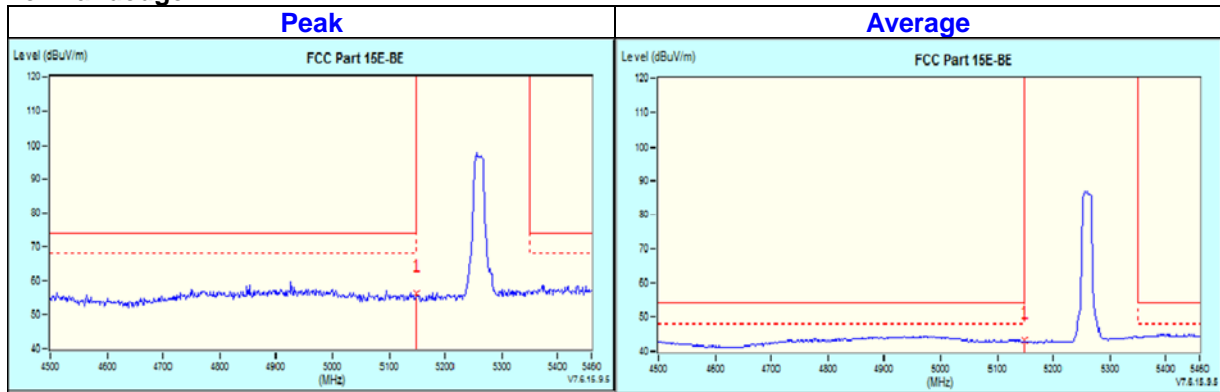

CHANNEL	TX Channel 52	DETECTOR FUNCTION	Peak (PK)
FREQUENCY RANGE	1GHz ~ 40GHz		Average (AV)

ANTENNA POLARITY & TEST DISTANCE: VERTICAL AT 3 M								
NO.	FREQ. (MHz)	EMISSION LEVEL (dBuV/m)	LIMIT (dBuV/m)	MARGIN (dB)	ANTENNA HEIGHT (m)	TABLE ANGLE (Degree)	RAW VALUE (dBuV)	CORRECTION FACTOR (dB/m)
1	5150.00	56.3 PK	74.0	-17.7	1.25 V	69	52.4	3.9
2	5150.00	43.1 AV	54.0	-10.9	1.25 V	69	39.2	3.9
3	*5260.00	103.2 PK			1.00 V	55	63.9	39.3
4	*5260.00	93.4 AV			1.00 V	55	54.1	39.3
5	#10520.00	65.0 PK	68.2	-3.2	1.50 V	330	48.1	16.9

Remarks:

1. Emission Level(dBuV/m) = Raw Value(dBuV) + Correction Factor(dB/m)
2. Correction Factor(dB/m) = Antenna Factor(dB/m) + Cable Factor(dB) – Pre-Amplifier Factor(dB)
3. The other emission levels were very low against the limit
4. Margin value = Emission Level – Limit value
5. " * ": Fundamental frequency
6. " # ": The radiated frequency is out of the restricted band.

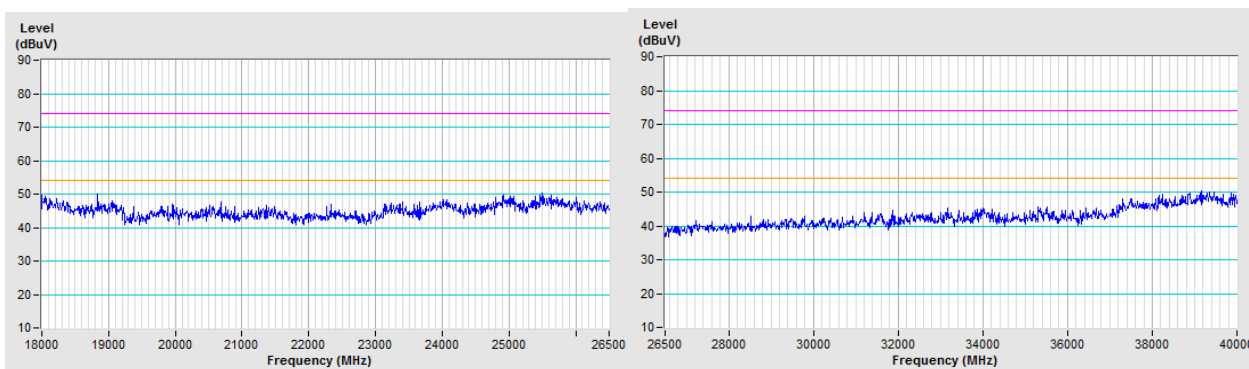
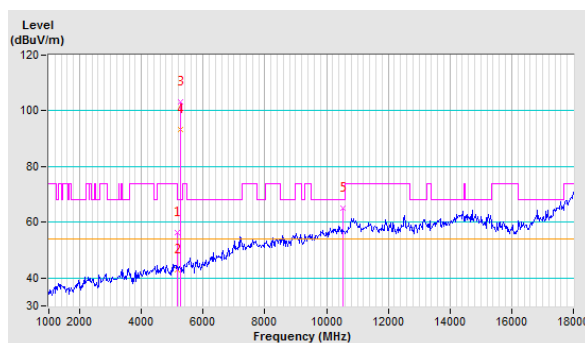

For Bandedge

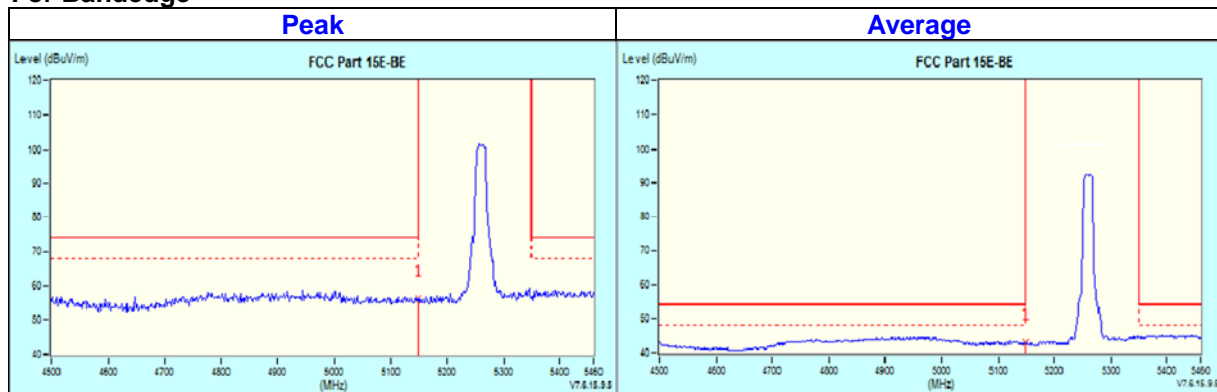

CHANNEL	TX Channel 60	DETECTOR FUNCTION	Peak (PK)
FREQUENCY RANGE	1GHz ~ 40GHz		Average (AV)

ANTENNA POLARITY & TEST DISTANCE: HORIZONTAL AT 3 M								
NO.	FREQ. (MHz)	EMISSION LEVEL (dBuV/m)	LIMIT (dBuV/m)	MARGIN (dB)	ANTENNA HEIGHT (m)	TABLE ANGLE (Degree)	RAW VALUE (dBuV)	CORRECTION FACTOR (dB/m)
1	*5300.00	97.7 PK			3.51 H	343	58.4	39.3
2	*5300.00	87.4 AV			3.51 H	343	48.1	39.3
3	5350.00	56.7 PK	74.0	-17.3	2.98 H	311	52.8	3.9
4	5350.00	43.5 AV	54.0	-10.5	2.98 H	311	39.6	3.9
5	10600.00	65.0 PK	74.0	-9.0	1.07 H	53	48.0	17.0
6	10600.00	49.3 AV	54.0	-4.7	1.07 H	53	32.3	17.0

Remarks:

1. Emission Level(dBuV/m) = Raw Value(dBuV) + Correction Factor(dB/m)
2. Correction Factor(dB/m) = Antenna Factor(dB/m) + Cable Factor(dB) – Pre-Amplifier Factor(dB)
3. The other emission levels were very low against the limit
4. Margin value = Emission Level – Limit value
5. " * ": Fundamental frequency

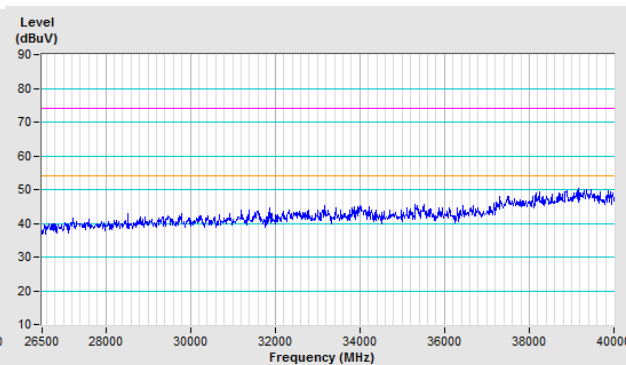
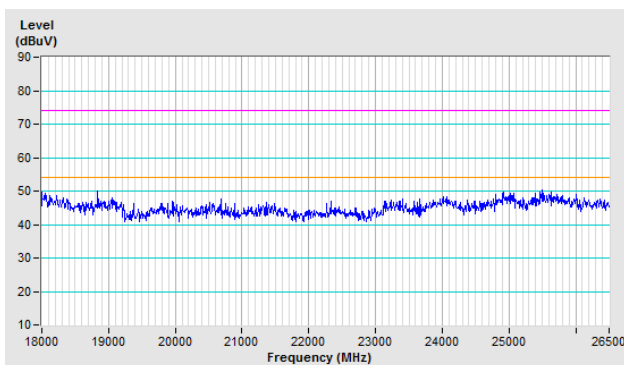
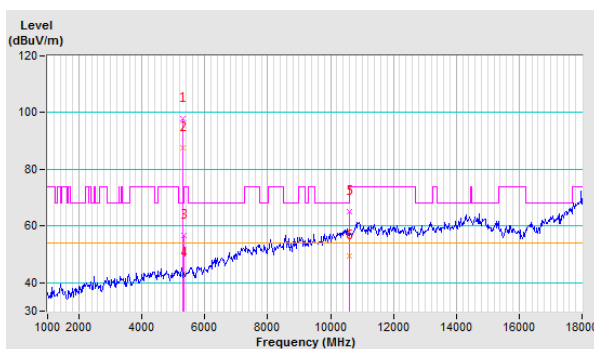

For Bandedge

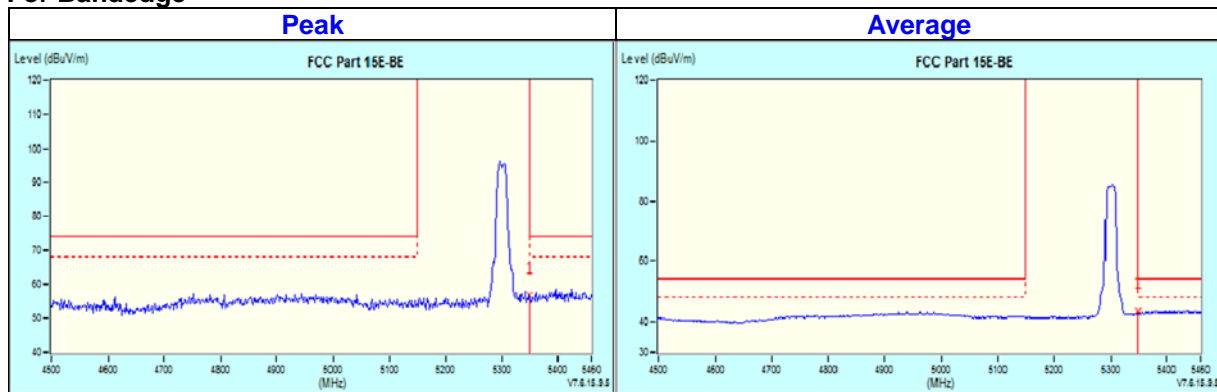

CHANNEL	TX Channel 60	DETECTOR FUNCTION	Peak (PK)
FREQUENCY RANGE	1GHz ~ 40GHz		Average (AV)

ANTENNA POLARITY & TEST DISTANCE: VERTICAL AT 3 M								
NO.	FREQ. (MHz)	EMISSION LEVEL (dBuV/m)	LIMIT (dBuV/m)	MARGIN (dB)	ANTENNA HEIGHT (m)	TABLE ANGLE (Degree)	RAW VALUE (dBuV)	CORRECTION FACTOR (dB/m)
1	*5300.00	102.2 PK			1.09 V	56	62.9	39.3
2	*5300.00	91.9 AV			1.09 V	56	52.6	39.3
3	5350.00	57.0 PK	74.0	-17.0	1.31 V	77	53.1	3.9
4	5350.00	43.6 AV	54.0	-10.4	1.31 V	77	39.7	3.9
5	10600.00	64.6 PK	74.0	-9.4	3.36 V	13	47.6	17.0
6	10600.00	50.7 AV	54.0	-3.3	3.36 V	13	33.7	17.0

Remarks:

1. Emission Level(dBuV/m) = Raw Value(dBuV) + Correction Factor(dB/m)
2. Correction Factor(dB/m) = Antenna Factor(dB/m) + Cable Factor(dB) – Pre-Amplifier Factor(dB)
3. The other emission levels were very low against the limit
4. Margin value = Emission Level – Limit value
5. " * ": Fundamental frequency

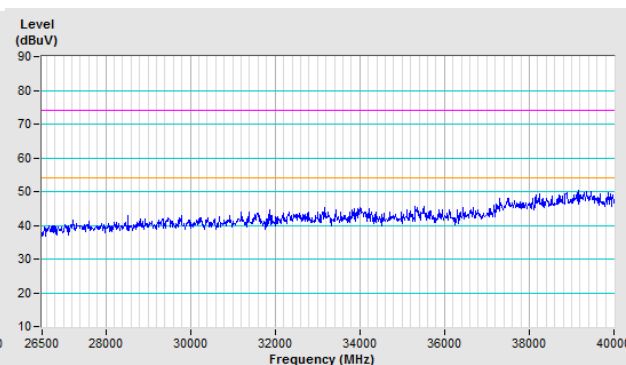
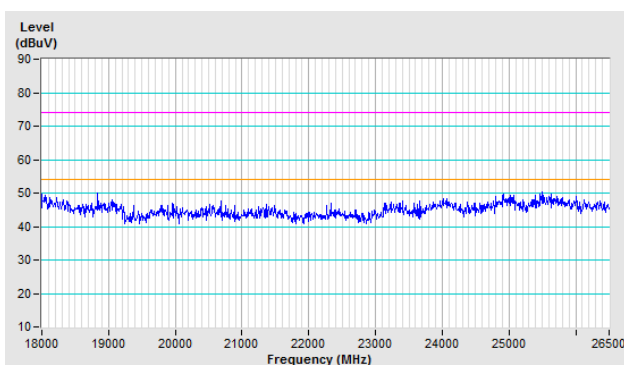
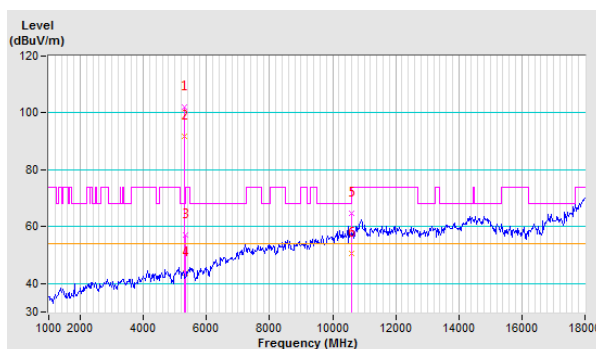

For Bandedge

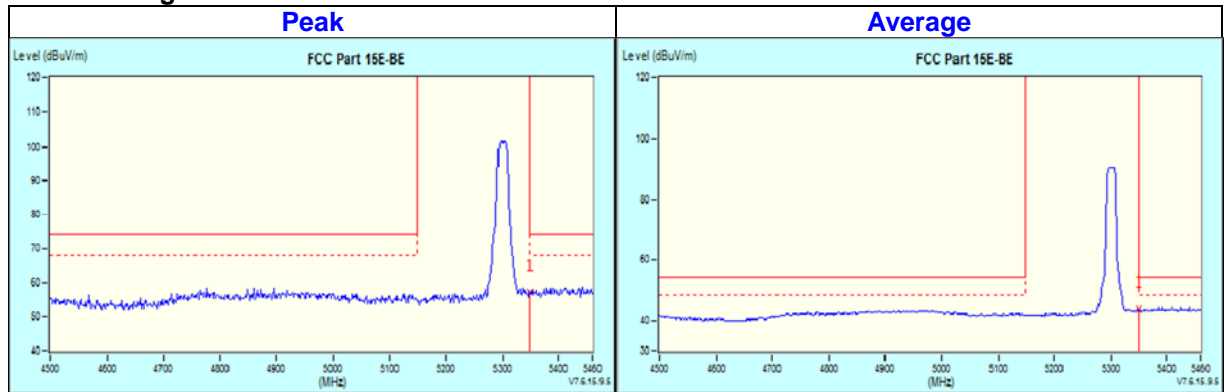

CHANNEL	TX Channel 64	DETECTOR FUNCTION	Peak (PK)
FREQUENCY RANGE	1GHz ~ 40GHz		Average (AV)

ANTENNA POLARITY & TEST DISTANCE: HORIZONTAL AT 3 M								
NO.	FREQ. (MHz)	EMISSION LEVEL (dBuV/m)	LIMIT (dBuV/m)	MARGIN (dB)	ANTENNA HEIGHT (m)	TABLE ANGLE (Degree)	RAW VALUE (dBuV)	CORRECTION FACTOR (dB/m)
1	*5320.00	95.9 PK			3.89 H	358	56.6	39.3
2	*5320.00	85.8 AV			3.89 H	358	46.5	39.3
3	5350.00	56.4 PK	74.0	-17.6	3.56 H	318	52.5	3.9
4	5350.00	43.1 AV	54.0	-10.9	3.56 H	318	39.2	3.9
5	10640.00	62.0 PK	74.0	-12.0	1.03 H	261	45.0	17.0
6	10640.00	48.6 AV	54.0	-5.4	1.03 H	261	31.6	17.0

Remarks:

1. Emission Level(dBuV/m) = Raw Value(dBuV) + Correction Factor(dB/m)
2. Correction Factor(dB/m) = Antenna Factor(dB/m) + Cable Factor(dB) – Pre-Amplifier Factor(dB)
3. The other emission levels were very low against the limit
4. Margin value = Emission Level – Limit value
5. " * ": Fundamental frequency

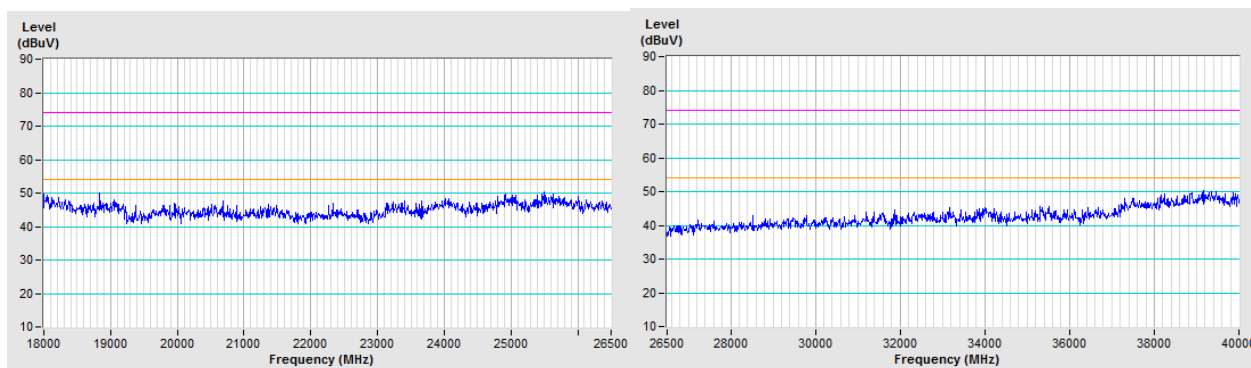
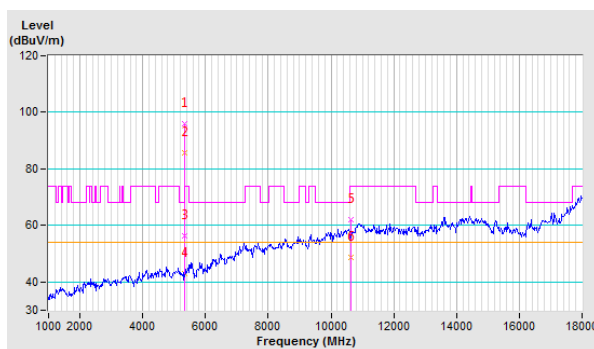

For Bandedge

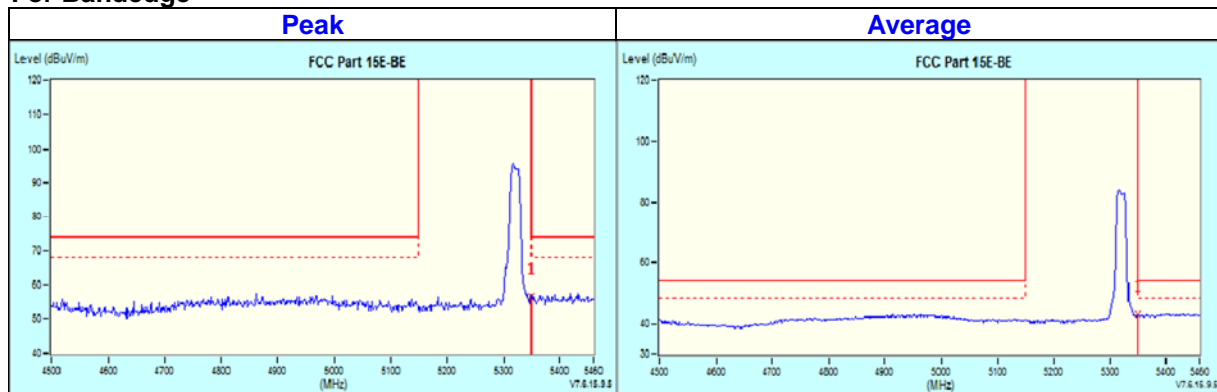

CHANNEL	TX Channel 64	DETECTOR FUNCTION	Peak (PK) Average (AV)
FREQUENCY RANGE	1GHz ~ 40GHz		

ANTENNA POLARITY & TEST DISTANCE: VERTICAL AT 3 M								
NO.	FREQ. (MHz)	EMISSION LEVEL (dBuV/m)	LIMIT (dBuV/m)	MARGIN (dB)	ANTENNA HEIGHT (m)	TABLE ANGLE (Degree)	RAW VALUE (dBuV)	CORRECTION FACTOR (dB/m)
1	*5320.00	99.0 PK			2.23 V	314	59.7	39.3
2	*5320.00	88.3 AV			2.23 V	314	49.0	39.3
3	5350.00	56.6 PK	74.0	-17.4	1.78 V	267	52.7	3.9
4	5350.00	43.3 AV	54.0	-10.7	1.78 V	267	39.4	3.9
5	10640.00	61.8 PK	74.0	-12.2	3.79 V	147	44.8	17.0
6	10640.00	50.9 AV	54.0	-3.1	3.79 V	147	33.9	17.0

Remarks:

1. Emission Level(dBuV/m) = Raw Value(dBuV) + Correction Factor(dB/m)
2. Correction Factor(dB/m) = Antenna Factor(dB/m) + Cable Factor(dB) – Pre-Amplifier Factor(dB)
3. The other emission levels were very low against the limit
4. Margin value = Emission Level – Limit value
5. " * ": Fundamental frequency

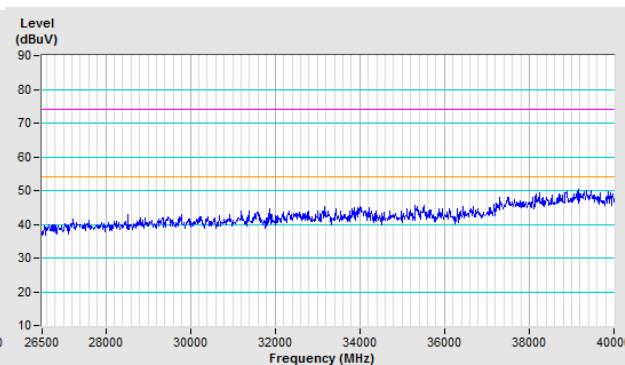
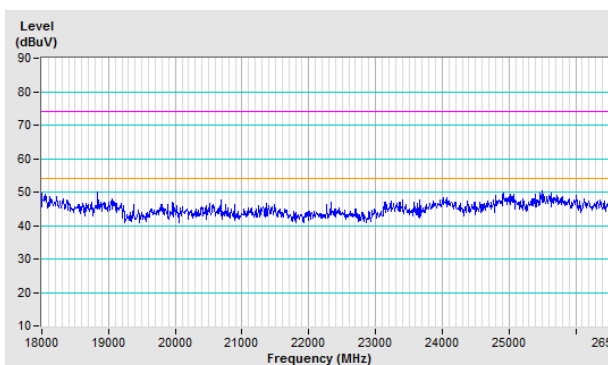
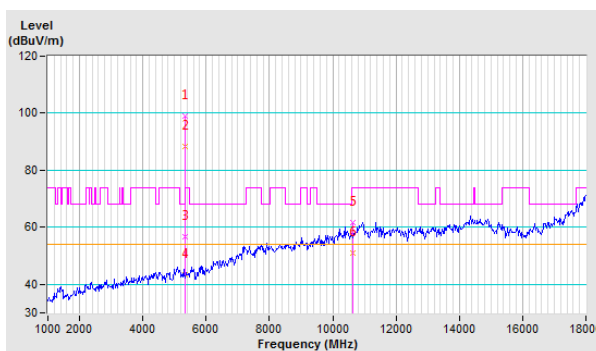

For Bandedge

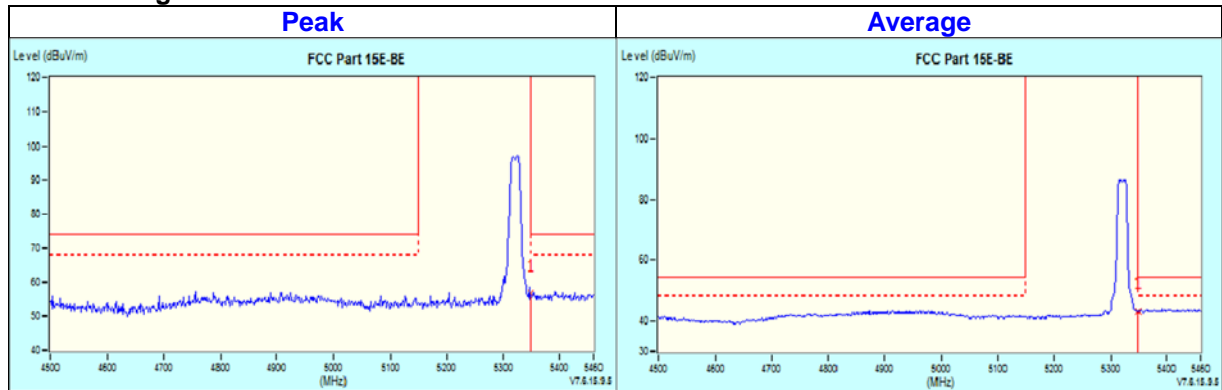

CHANNEL	TX Channel 100	DETECTOR FUNCTION	Peak (PK)
FREQUENCY RANGE	1GHz ~ 40GHz		Average (AV)

ANTENNA POLARITY & TEST DISTANCE: HORIZONTAL AT 3 M								
NO.	FREQ. (MHz)	EMISSION LEVEL (dBuV/m)	LIMIT (dBuV/m)	MARGIN (dB)	ANTENNA HEIGHT (m)	TABLE ANGLE (Degree)	RAW VALUE (dBuV)	CORRECTION FACTOR (dB/m)
1	5460.00	55.0 PK	74.0	-19.0	1.56 H	290	50.9	4.1
2	5460.00	42.7 AV	54.0	-11.3	1.56 H	290	38.6	4.1
3	#5470.00	57.0 PK	68.2	-11.2	1.22 H	269	52.9	4.1
4	*5500.00	97.2 PK			1.04 H	236	57.4	39.8
5	*5500.00	87.4 AV			1.04 H	236	47.6	39.8
6	11000.00	61.6 PK	74.0	-12.4	1.03 H	283	43.2	18.4
7	11000.00	47.4 AV	54.0	-6.6	1.03 H	283	29.0	18.4

Remarks:

1. Emission Level(dBuV/m) = Raw Value(dBuV) + Correction Factor(dB/m)
2. Correction Factor(dB/m) = Antenna Factor(dB/m) + Cable Factor(dB) – Pre-Amplifier Factor(dB)
3. The other emission levels were very low against the limit
4. Margin value = Emission Level – Limit value
5. " * ": Fundamental frequency

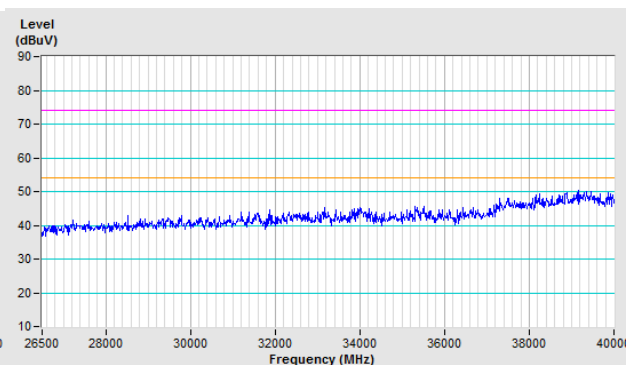
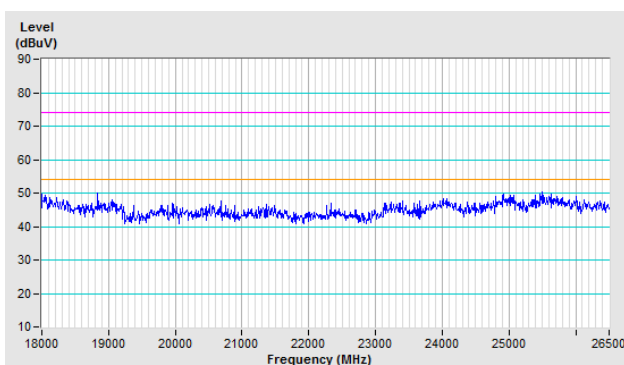
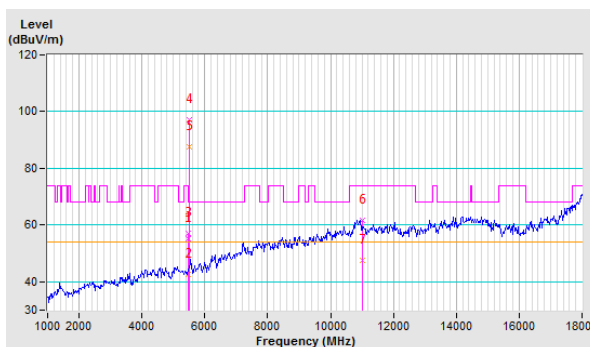

For Bandedge

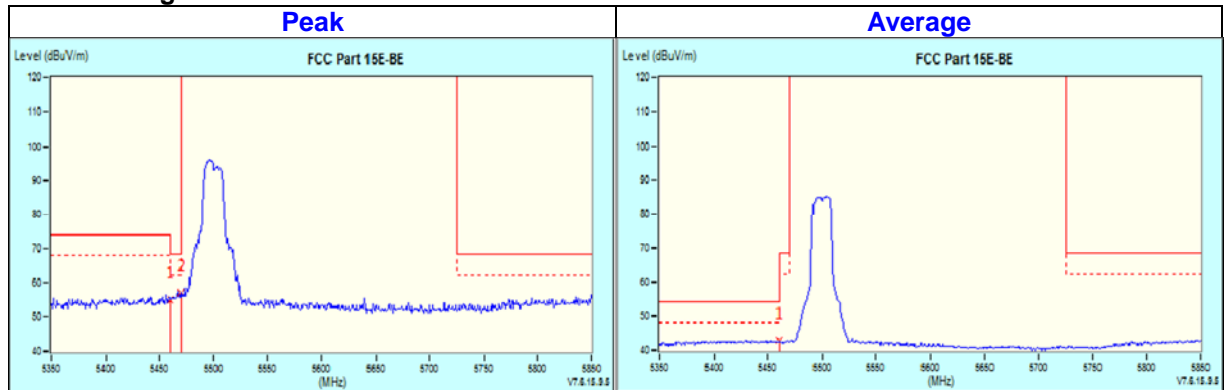

CHANNEL	TX Channel 100	DETECTOR FUNCTION	Peak (PK) Average (AV)
FREQUENCY RANGE	1GHz ~ 40GHz		

ANTENNA POLARITY & TEST DISTANCE: VERTICAL AT 3 M								
NO.	FREQ. (MHz)	EMISSION LEVEL (dBuV/m)	LIMIT (dBuV/m)	MARGIN (dB)	ANTENNA HEIGHT (m)	TABLE ANGLE (Degree)	RAW VALUE (dBuV)	CORRECTION FACTOR (dB/m)
1	5460.00	55.4 PK	74.0	-18.6	2.41 V	323	51.3	4.1
2	5460.00	43.1 AV	54.0	-10.9	2.41 V	323	39.0	4.1
3	#5470.00	58.3 PK	68.2	-9.9	2.23 V	316	54.2	4.1
4	*5500.00	101.9 PK			1.85 V	327	62.1	39.8
5	*5500.00	92.2 AV			1.85 V	327	52.4	39.8
6	11000.00	63.6 PK	74.0	-10.4	3.65 V	29	45.2	18.4
7	11000.00	47.6 AV	54.0	-6.4	3.65 V	29	29.2	18.4

Remarks:

1. Emission Level(dBuV/m) = Raw Value(dBuV) + Correction Factor(dB/m)
2. Correction Factor(dB/m) = Antenna Factor(dB/m) + Cable Factor(dB) – Pre-Amplifier Factor(dB)
3. The other emission levels were very low against the limit
4. Margin value = Emission Level – Limit value
5. " * ": Fundamental frequency

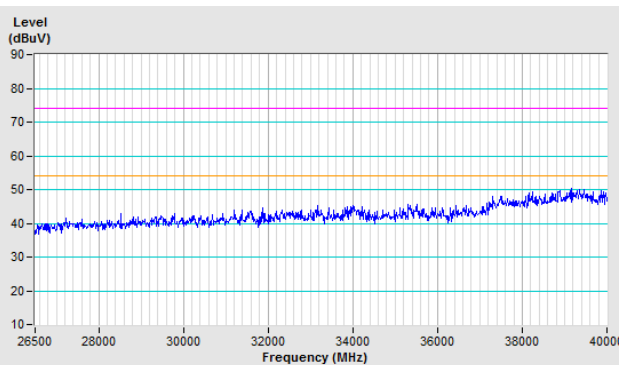
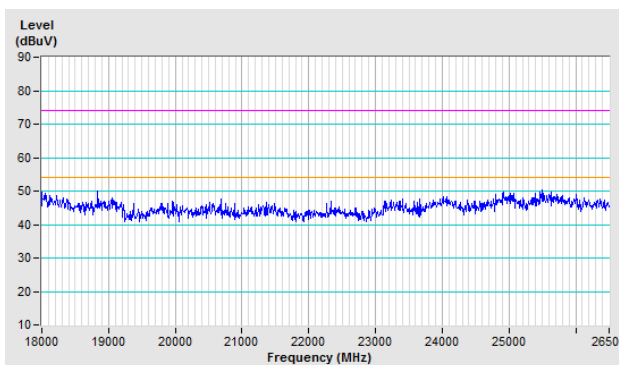
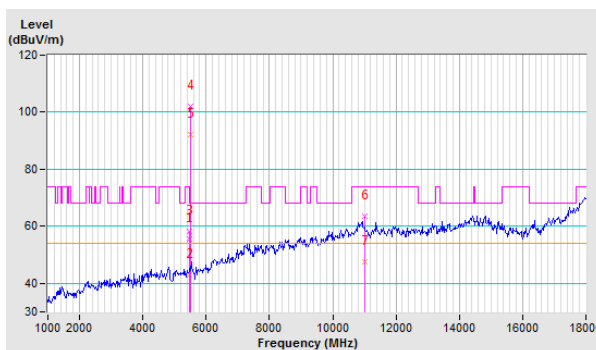

For Bandedge

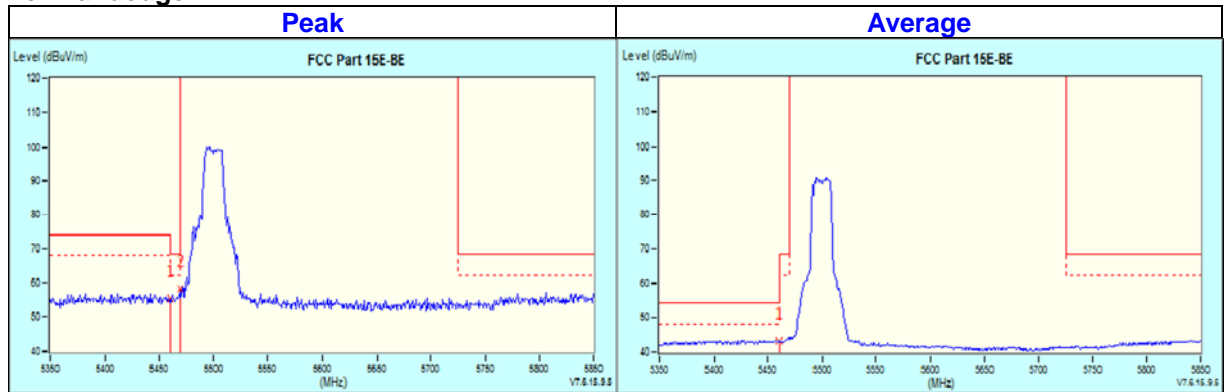

CHANNEL	TX Channel 116	DETECTOR FUNCTION	Peak (PK)
FREQUENCY RANGE	1GHz ~ 40GHz		Average (AV)

ANTENNA POLARITY & TEST DISTANCE: HORIZONTAL AT 3 M								
NO.	FREQ. (MHz)	EMISSION LEVEL (dBuV/m)	LIMIT (dBuV/m)	MARGIN (dB)	ANTENNA HEIGHT (m)	TABLE ANGLE (Degree)	RAW VALUE (dBuV)	CORRECTION FACTOR (dB/m)
1	*5580.00	103.1 PK			1.01 H	284	63.3	39.8
2	*5580.00	93.2 AV			1.01 H	284	53.4	39.8
3	#5725.00	55.0 PK	68.2	-13.2	1.32 H	296	50.6	4.4
4	11160.00	64.3 PK	74.0	-9.7	1.10 H	313	46.8	17.5
5	11160.00	49.9 AV	54.0	-4.1	1.10 H	313	32.4	17.5

Remarks:

1. Emission Level(dBuV/m) = Raw Value(dBuV) + Correction Factor(dB/m)
2. Correction Factor(dB/m) = Antenna Factor(dB/m) + Cable Factor(dB) – Pre-Amplifier Factor(dB)
3. The other emission levels were very low against the limit
4. Margin value = Emission Level – Limit value
5. " * ": Fundamental frequency

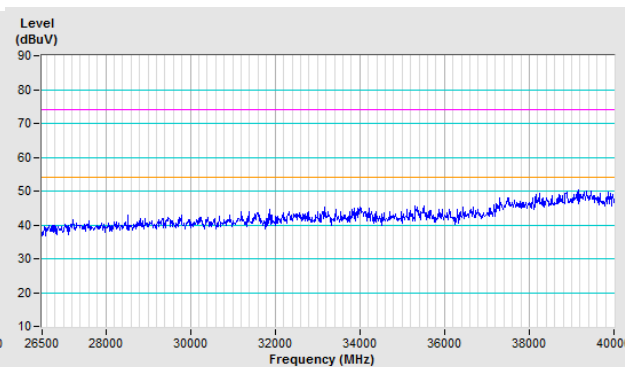
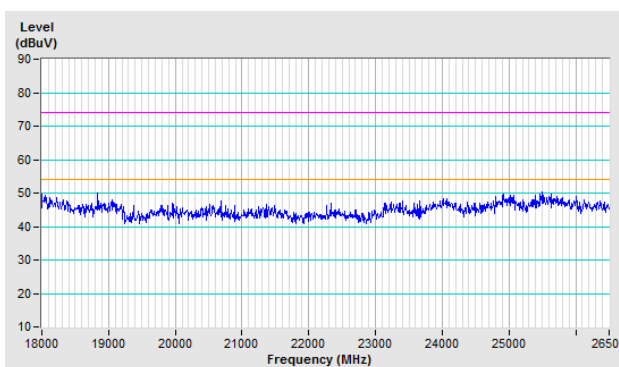
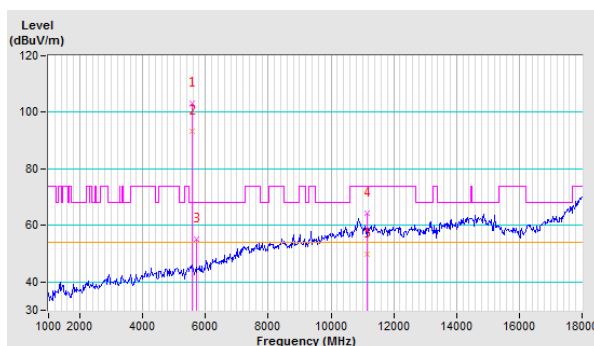

For Bandedge

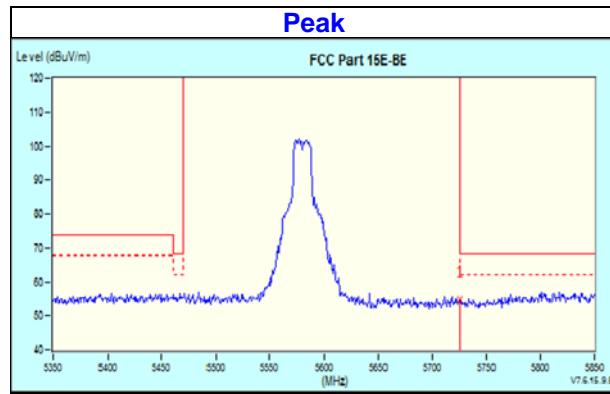

CHANNEL	TX Channel 116	DETECTOR FUNCTION	Peak (PK) Average (AV)
FREQUENCY RANGE	1GHz ~ 40GHz		

ANTENNA POLARITY & TEST DISTANCE: VERTICAL AT 3 M								
NO.	FREQ. (MHz)	EMISSION LEVEL (dBuV/m)	LIMIT (dBuV/m)	MARGIN (dB)	ANTENNA HEIGHT (m)	TABLE ANGLE (Degree)	RAW VALUE (dBuV)	CORRECTION FACTOR (dB/m)
1	*5580.00	105.7 PK			1.06 V	58	65.9	39.8
2	*5580.00	96.0 AV			1.06 V	58	56.2	39.8
3	#5725.00	55.7 PK	68.2	-12.5	1.19 V	93	51.3	4.4
4	11160.00	63.8 PK	74.0	-10.2	1.11 V	306	46.3	17.5
5	11160.00	50.5 AV	54.0	-3.5	1.11 V	306	33.0	17.5

Remarks:

1. Emission Level(dBuV/m) = Raw Value(dBuV) + Correction Factor(dB/m)
2. Correction Factor(dB/m) = Antenna Factor(dB/m) + Cable Factor(dB) – Pre-Amplifier Factor(dB)
3. The other emission levels were very low against the limit
4. Margin value = Emission Level – Limit value
5. " * ": Fundamental frequency

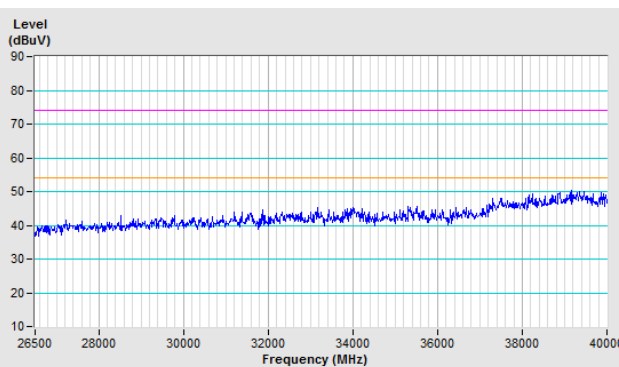
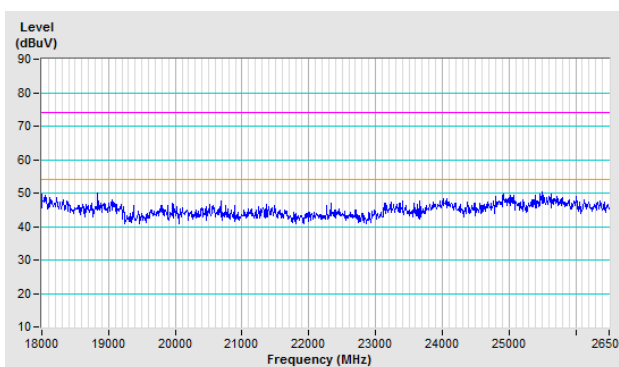
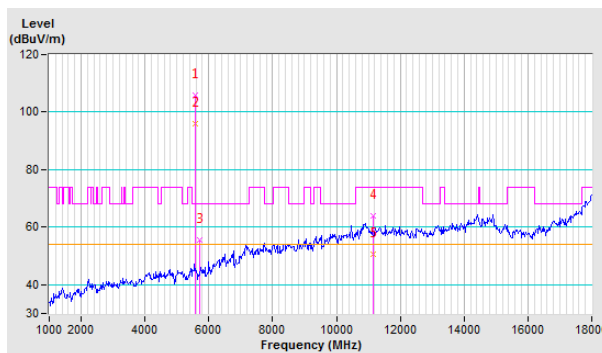

For Bandedge

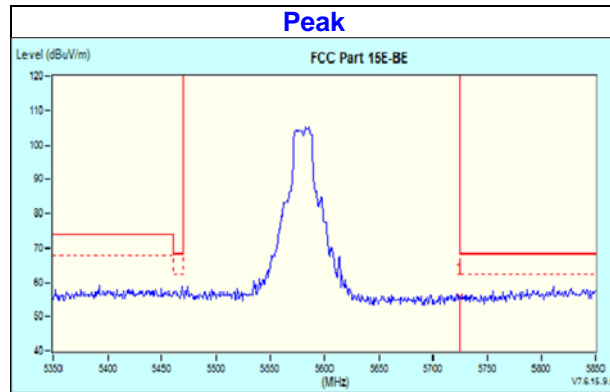

CHANNEL	TX Channel 140	DETECTOR FUNCTION	Peak (PK)
FREQUENCY RANGE	1GHz ~ 40GHz		Average (AV)

ANTENNA POLARITY & TEST DISTANCE: HORIZONTAL AT 3 M								
NO.	FREQ. (MHz)	EMISSION LEVEL (dBuV/m)	LIMIT (dBuV/m)	MARGIN (dB)	ANTENNA HEIGHT (m)	TABLE ANGLE (Degree)	RAW VALUE (dBuV)	CORRECTION FACTOR (dB/m)
1	*5700.00	103.1 PK			1.08 H	288	63.3	39.8
2	*5700.00	93.6 AV			1.08 H	288	53.8	39.8
3	#5725.00	63.8 PK	68.2	-4.4	1.36 H	287	59.4	4.4
4	11400.00	63.4 PK	74.0	-10.6	1.07 H	308	46.1	17.3
5	11400.00	49.5 AV	54.0	-4.5	1.07 H	308	32.2	17.3

Remarks:

1. Emission Level(dBuV/m) = Raw Value(dBuV) + Correction Factor(dB/m)
2. Correction Factor(dB/m) = Antenna Factor(dB/m) + Cable Factor(dB) – Pre-Amplifier Factor(dB)
3. The other emission levels were very low against the limit
4. Margin value = Emission Level – Limit value
5. " * ": Fundamental frequency

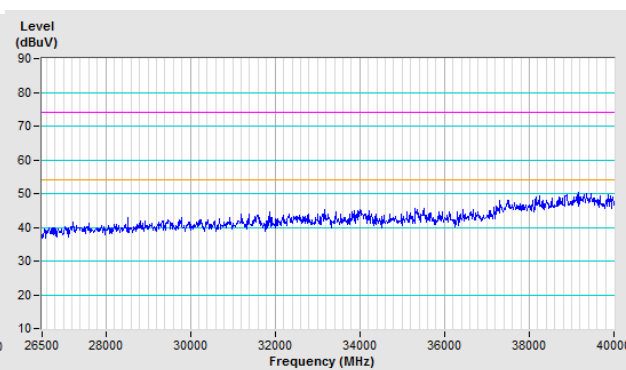
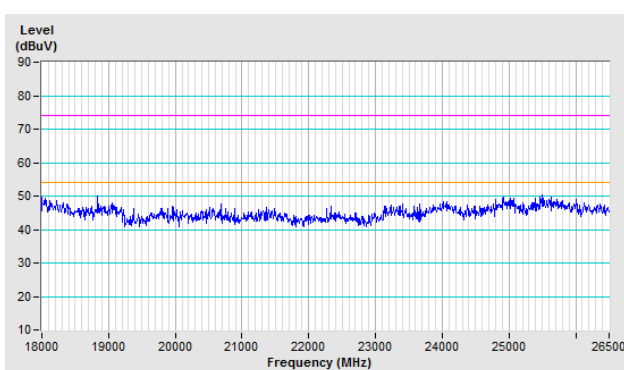
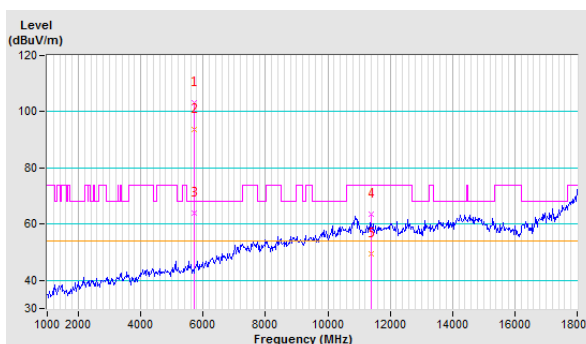

For Bandedge

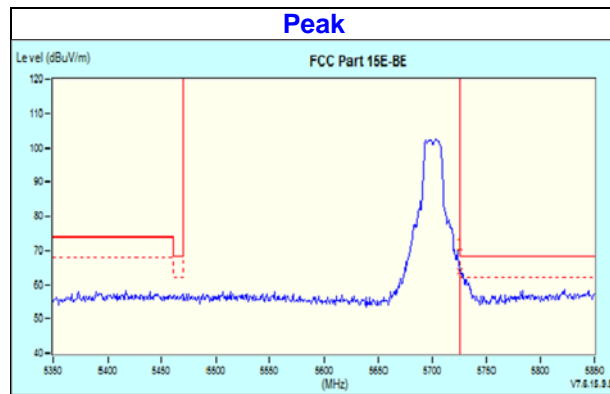

CHANNEL	TX Channel 140	DETECTOR FUNCTION	Peak (PK) Average (AV)
FREQUENCY RANGE	1GHz ~ 40GHz		

ANTENNA POLARITY & TEST DISTANCE: VERTICAL AT 3 M								
NO.	FREQ. (MHz)	EMISSION LEVEL (dBuV/m)	LIMIT (dBuV/m)	MARGIN (dB)	ANTENNA HEIGHT (m)	TABLE ANGLE (Degree)	RAW VALUE (dBuV)	CORRECTION FACTOR (dB/m)
1	*5700.00	102.9 PK			1.02 V	60	63.1	39.8
2	*5700.00	92.8 AV			1.02 V	60	53.0	39.8
3	#5725.00	62.8 PK	68.2	-5.4	1.03 V	63	58.4	4.4
4	11400.00	65.3 PK	74.0	-8.7	1.03 V	314	48.0	17.3
5	11400.00	50.6 AV	54.0	-3.4	1.03 V	314	33.3	17.3

Remarks:

1. Emission Level(dBuV/m) = Raw Value(dBuV) + Correction Factor(dB/m)
2. Correction Factor(dB/m) = Antenna Factor(dB/m) + Cable Factor(dB) – Pre-Amplifier Factor(dB)
3. The other emission levels were very low against the limit
4. Margin value = Emission Level – Limit value
5. " * ": Fundamental frequency

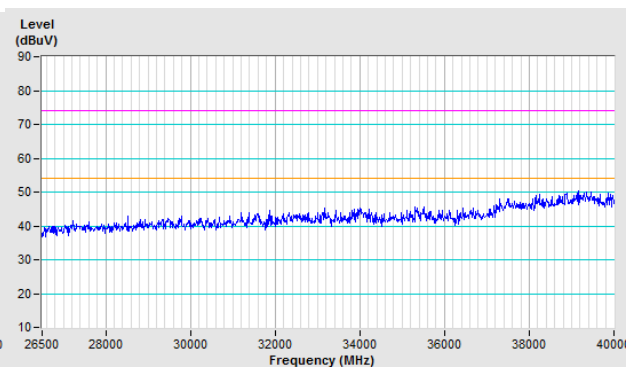
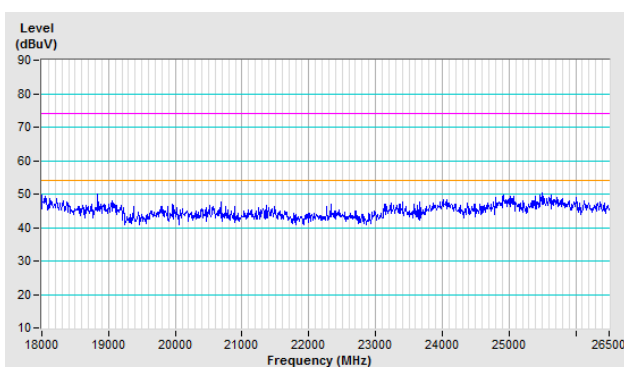
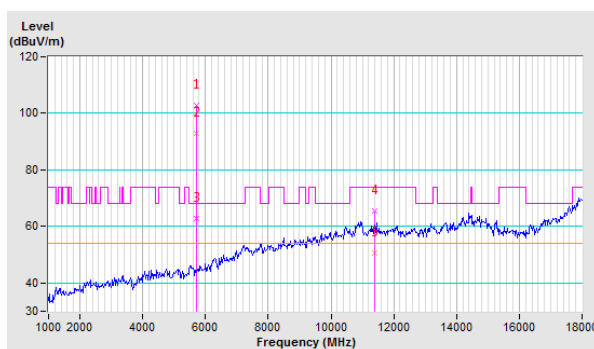

For Bandedge

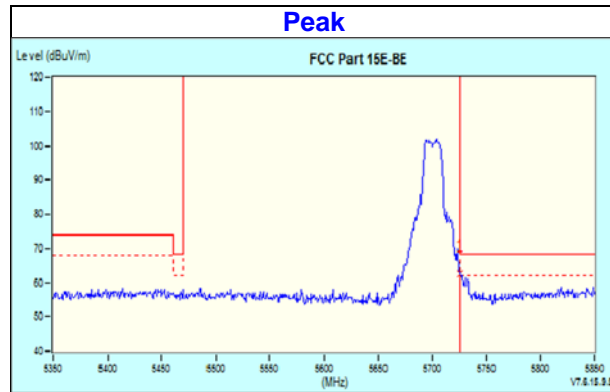

CHANNEL	TX Channel 149	DETECTOR FUNCTION	Peak (PK)
FREQUENCY RANGE	1GHz ~ 40GHz		Average (AV)

ANTENNA POLARITY & TEST DISTANCE: HORIZONTAL AT 3 M								
NO.	FREQ. (MHz)	EMISSION LEVEL (dBuV/m)	LIMIT (dBuV/m)	MARGIN (dB)	ANTENNA HEIGHT (m)	TABLE ANGLE (Degree)	RAW VALUE (dBuV)	CORRECTION FACTOR (dB/m)
1	#5626.92	54.1 PK	68.2	-14.1	1.24 H	288	49.9	4.2
2	*5745.00	103.2 PK			1.24 H	288	63.1	40.1
3	*5745.00	93.3 AV			1.24 H	288	53.2	40.1
4	#5983.97	57.3 PK	68.2	-10.9	1.24 H	288	52.2	5.1
5	11490.00	62.9 PK	74.0	-11.1	1.09 H	301	45.3	17.6
6	11490.00	49.4 AV	54.0	-4.6	1.09 H	301	31.8	17.6

Remarks:

1. Emission Level(dBuV/m) = Raw Value(dBuV) + Correction Factor(dB/m)
2. Correction Factor(dB/m) = Antenna Factor(dB/m) + Cable Factor(dB) – Pre-Amplifier Factor(dB)
3. The other emission levels were very low against the limit
4. Margin value = Emission Level – Limit value
5. " * ": Fundamental frequency

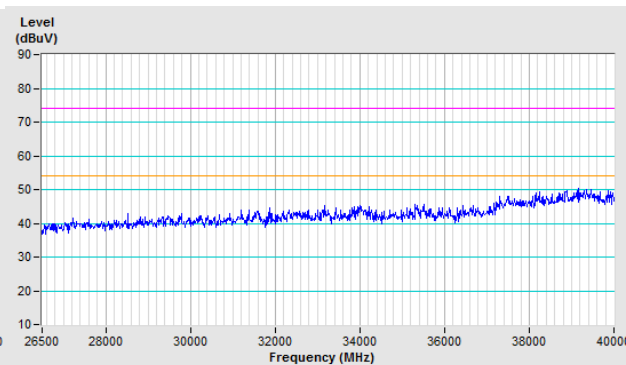
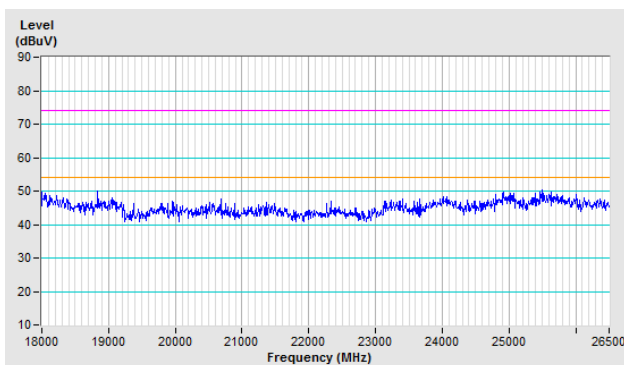
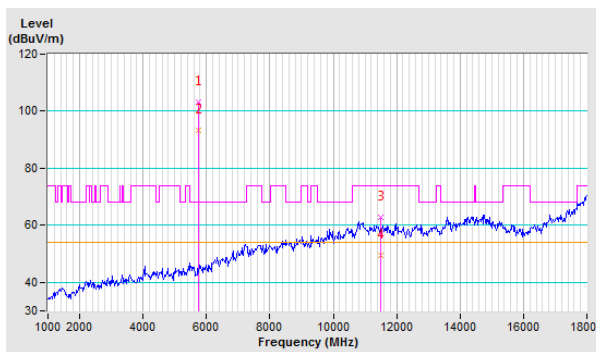

For Bandedge

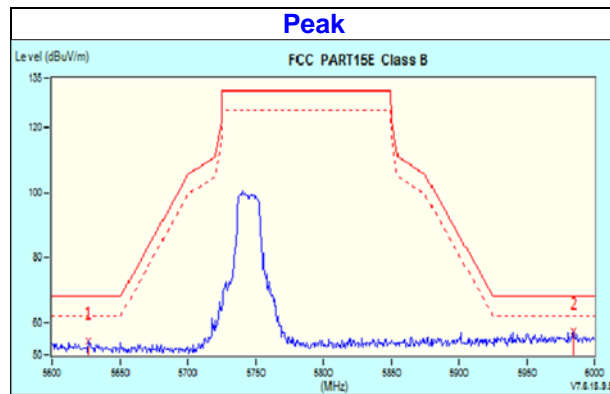

CHANNEL	TX Channel 149	DETECTOR FUNCTION	Peak (PK) Average (AV)
FREQUENCY RANGE	1GHz ~ 40GHz		

ANTENNA POLARITY & TEST DISTANCE: VERTICAL AT 3 M								
NO.	FREQ. (MHz)	EMISSION LEVEL (dBuV/m)	LIMIT (dBuV/m)	MARGIN (dB)	ANTENNA HEIGHT (m)	TABLE ANGLE (Degree)	RAW VALUE (dBuV)	CORRECTION FACTOR (dB/m)
1	#5604.49	54.6 PK	68.2	-13.6	1.06 V	59	50.3	4.3
2	*5745.00	102.1 PK			1.06 V	59	62.0	40.1
3	*5745.00	92.1 AV			1.06 V	59	52.0	40.1
4	#5950.00	56.8 PK	68.2	-11.4	1.06 V	59	51.9	4.9
5	11490.00	64.6 PK	74.0	-9.4	1.16 V	319	47.0	17.6
6	11490.00	50.8 AV	54.0	-3.2	1.16 V	319	33.2	17.6

Remarks:

1. Emission Level(dBuV/m) = Raw Value(dBuV) + Correction Factor(dB/m)
2. Correction Factor(dB/m) = Antenna Factor(dB/m) + Cable Factor(dB) – Pre-Amplifier Factor(dB)
3. The other emission levels were very low against the limit
4. Margin value = Emission Level – Limit value
5. " * ": Fundamental frequency

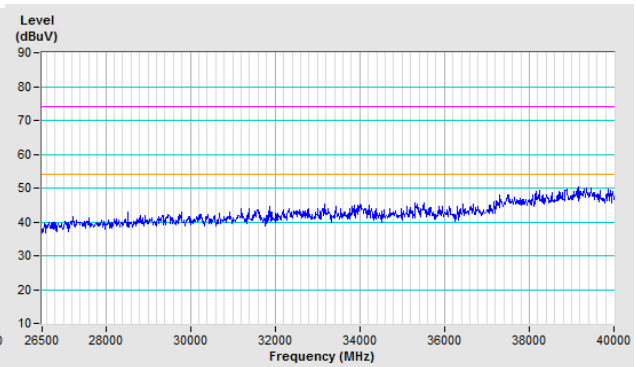
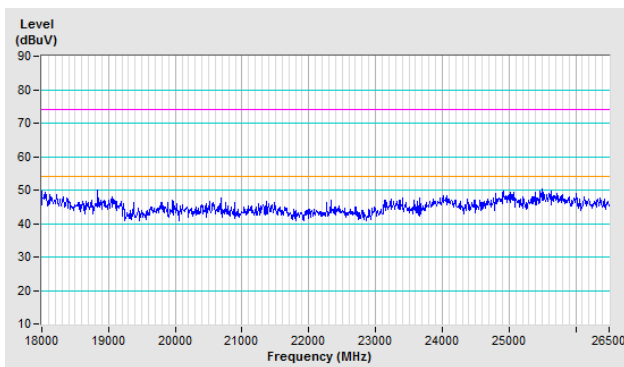
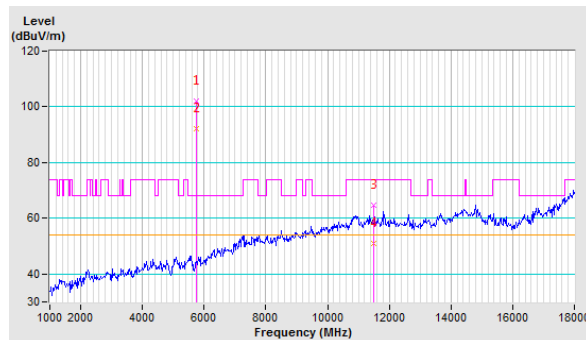

For Bandedge

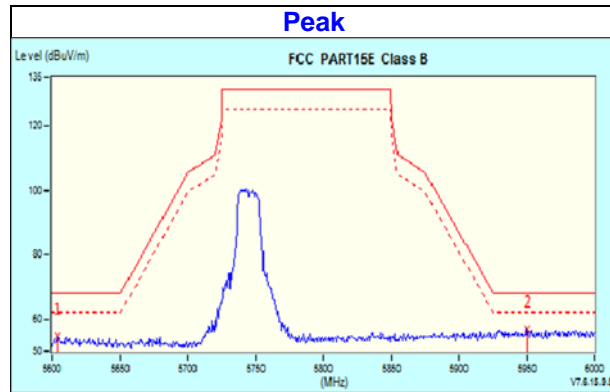

CHANNEL	TX Channel 157	DETECTOR FUNCTION	Peak (PK)
FREQUENCY RANGE	1GHz ~ 40GHz		Average (AV)

ANTENNA POLARITY & TEST DISTANCE: HORIZONTAL AT 3 M								
NO.	FREQ. (MHz)	EMISSION LEVEL (dBuV/m)	LIMIT (dBuV/m)	MARGIN (dB)	ANTENNA HEIGHT (m)	TABLE ANGLE (Degree)	RAW VALUE (dBuV)	CORRECTION FACTOR (dB/m)
1	#5605.13	54.2 PK	68.2	-14.0	1.26 H	292	49.9	4.3
2	*5785.00	103.6 PK			1.26 H	292	63.3	40.3
3	*5785.00	93.2 AV			1.26 H	292	52.9	40.3
4	#5930.13	56.9 PK	68.2	-11.3	1.62 H	292	52.0	4.9
5	11570.00	63.8 PK	74.0	-10.2	1.16 H	267	46.3	17.5
6	11570.00	49.4 AV	54.0	-4.6	1.16 H	267	31.9	17.5

Remarks:

1. Emission Level(dBuV/m) = Raw Value(dBuV) + Correction Factor(dB/m)
2. Correction Factor(dB/m) = Antenna Factor(dB/m) + Cable Factor(dB) – Pre-Amplifier Factor(dB)
3. The other emission levels were very low against the limit
4. Margin value = Emission Level – Limit value
5. " * ": Fundamental frequency

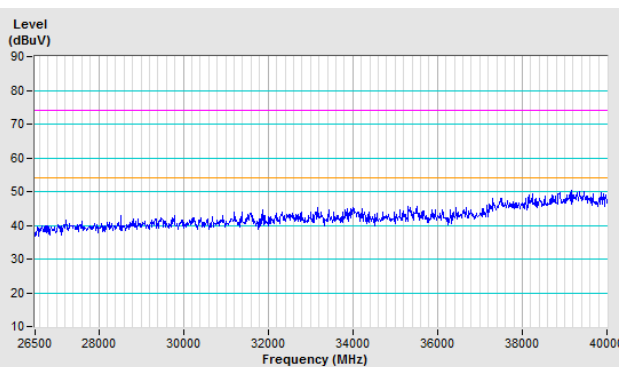
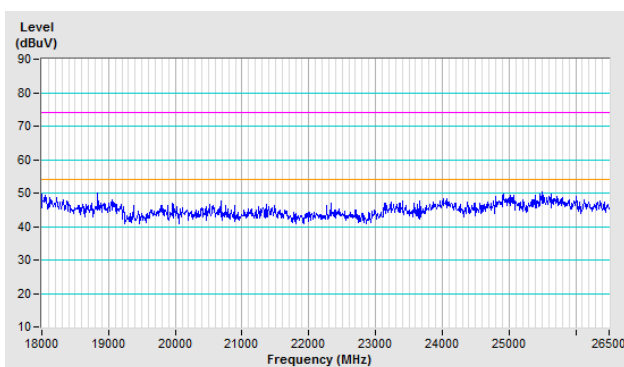
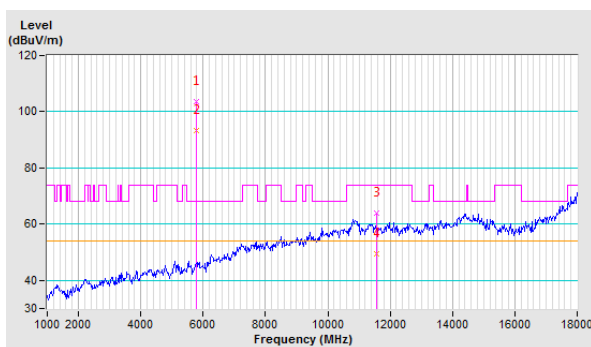

For Bandedge

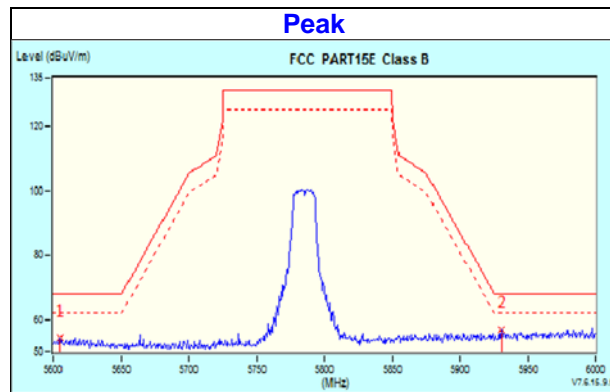

CHANNEL	TX Channel 157	DETECTOR FUNCTION	Peak (PK) Average (AV)
FREQUENCY RANGE	1GHz ~ 40GHz		

ANTENNA POLARITY & TEST DISTANCE: VERTICAL AT 3 M								
NO.	FREQ. (MHz)	EMISSION LEVEL (dBuV/m)	LIMIT (dBuV/m)	MARGIN (dB)	ANTENNA HEIGHT (m)	TABLE ANGLE (Degree)	RAW VALUE (dBuV)	CORRECTION FACTOR (dB/m)
1	#5609.62	54.2 PK	68.2	-14.0	1.19 V	61	49.9	4.3
2	*5785.00	102.1 PK			1.19 V	61	61.8	40.3
3	*5785.00	92.0 AV			1.19 V	61	51.7	40.3
4	#5928.21	57.0 PK	68.2	-11.2	1.19 V	61	52.1	4.9
5	11570.00	65.0 PK	74.0	-9.0	1.18 V	314	47.5	17.5
6	11570.00	50.7 AV	54.0	-3.3	1.18 V	314	33.2	17.5

Remarks:

1. Emission Level(dBuV/m) = Raw Value(dBuV) + Correction Factor(dB/m)
2. Correction Factor(dB/m) = Antenna Factor(dB/m) + Cable Factor(dB) – Pre-Amplifier Factor(dB)
3. The other emission levels were very low against the limit
4. Margin value = Emission Level – Limit value
5. " * ": Fundamental frequency

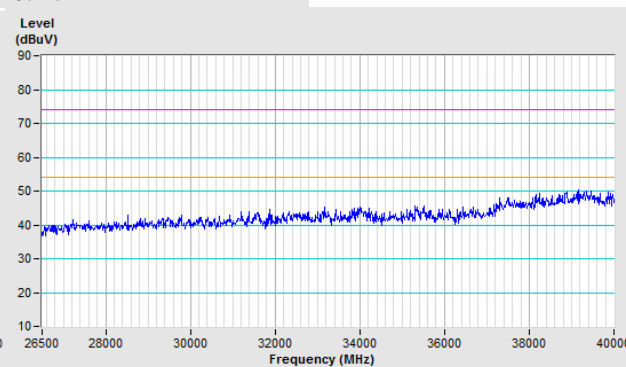
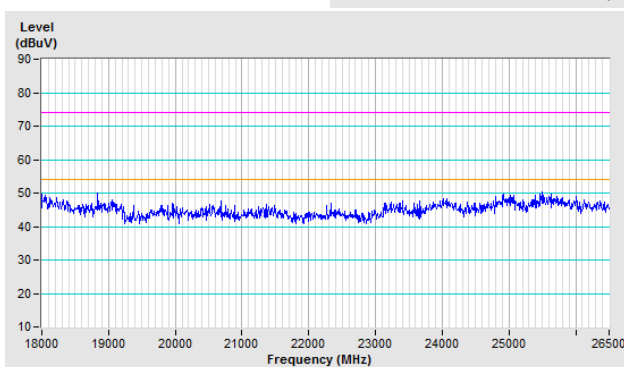
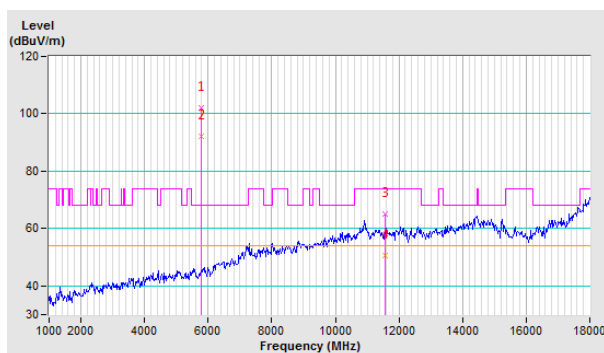

For Bandedge

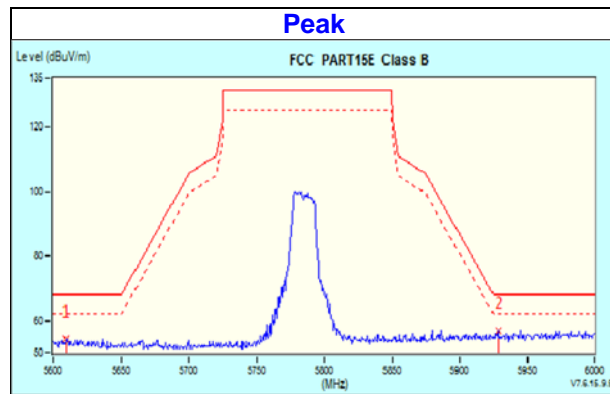

CHANNEL	TX Channel 165	DETECTOR FUNCTION	Peak (PK)
FREQUENCY RANGE	1GHz ~ 40GHz		Average (AV)

ANTENNA POLARITY & TEST DISTANCE: HORIZONTAL AT 3 M								
NO.	FREQ. (MHz)	EMISSION LEVEL (dBuV/m)	LIMIT (dBuV/m)	MARGIN (dB)	ANTENNA HEIGHT (m)	TABLE ANGLE (Degree)	RAW VALUE (dBuV)	CORRECTION FACTOR (dB/m)
1	#5621.15	54.2 PK	68.2	-14.0	1.11 H	286	49.9	4.3
2	*5825.00	104.1 PK			1.11 H	286	63.7	40.4
3	*5825.00	93.8 AV			1.11 H	286	53.4	40.4
4	#5974.36	56.8 PK	68.2	-11.4	1.11 H	286	51.7	5.1
5	11650.00	64.1 PK	74.0	-9.9	1.15 H	268	47.0	17.1
6	11650.00	49.9 AV	54.0	-4.1	1.15 H	268	32.8	17.1

Remarks:

1. Emission Level(dBuV/m) = Raw Value(dBuV) + Correction Factor(dB/m)
2. Correction Factor(dB/m) = Antenna Factor(dB/m) + Cable Factor(dB) – Pre-Amplifier Factor(dB)
3. The other emission levels were very low against the limit
4. Margin value = Emission Level – Limit value
5. " * ": Fundamental frequency

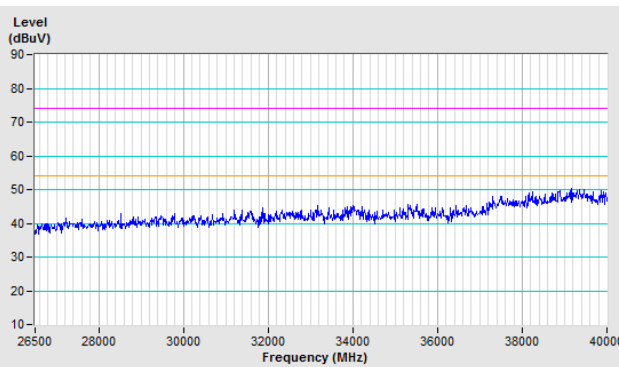
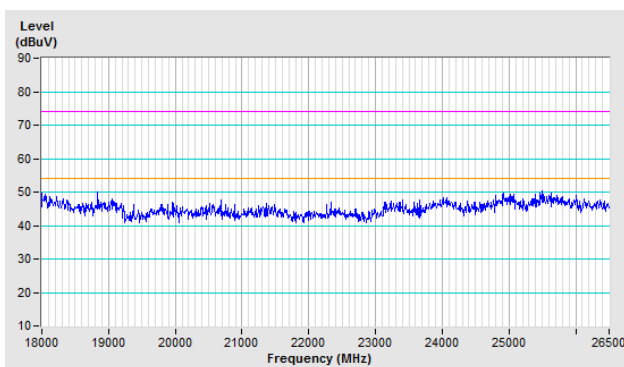
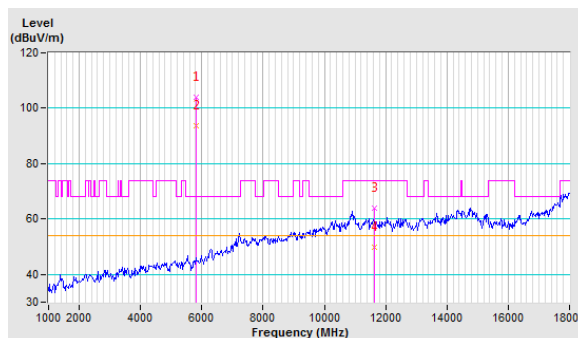

For Bandedge

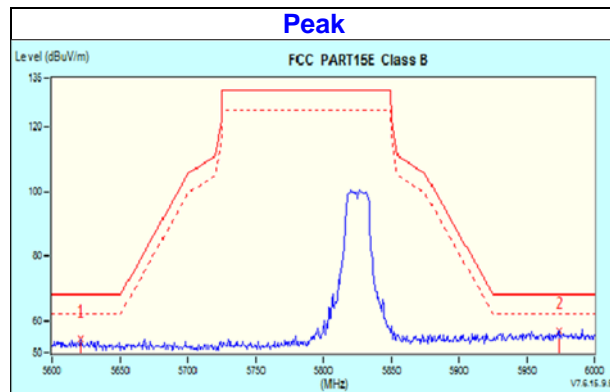

CHANNEL	TX Channel 165	DETECTOR FUNCTION	Peak (PK) Average (AV)
FREQUENCY RANGE	1GHz ~ 40GHz		

ANTENNA POLARITY & TEST DISTANCE: VERTICAL AT 3 M								
NO.	FREQ. (MHz)	EMISSION LEVEL (dBuV/m)	LIMIT (dBuV/m)	MARGIN (dB)	ANTENNA HEIGHT (m)	TABLE ANGLE (Degree)	RAW VALUE (dBuV)	CORRECTION FACTOR (dB/m)
1	#5603.85	54.2 PK	68.2	-14.0	1.03 V	57	49.9	4.3
2	*5825.00	102.5 PK			1.03 V	57	62.1	40.4
3	*5825.00	92.8 AV			1.03 V	57	52.4	40.4
4	#5990.38	57.0 PK	68.2	-11.2	1.03 V	57	51.9	5.1
5	11650.00	65.3 PK	74.0	-8.7	1.30 V	312	48.2	17.1
6	11650.00	51.0 AV	54.0	-3.0	1.30 V	312	33.9	17.1

Remarks:

1. Emission Level(dBuV/m) = Raw Value(dBuV) + Correction Factor(dB/m)
2. Correction Factor(dB/m) = Antenna Factor(dB/m) + Cable Factor(dB) – Pre-Amplifier Factor(dB)
3. The other emission levels were very low against the limit
4. Margin value = Emission Level – Limit value
5. " * ": Fundamental frequency

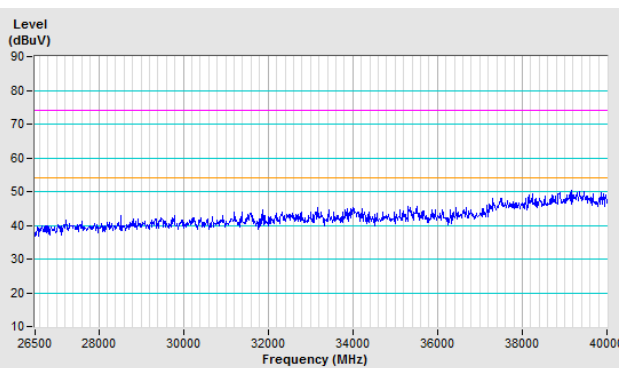
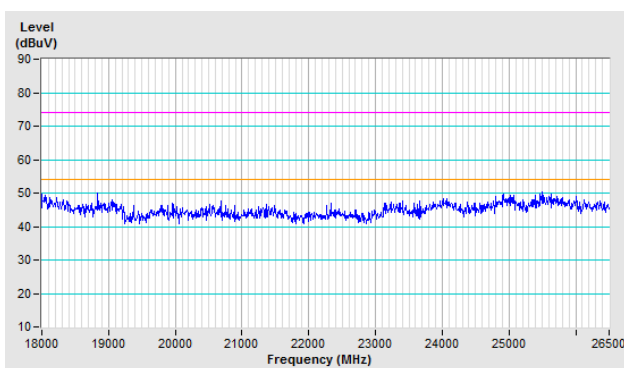
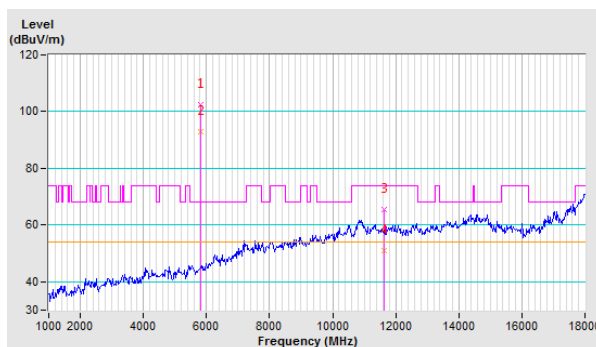

For Bandedge

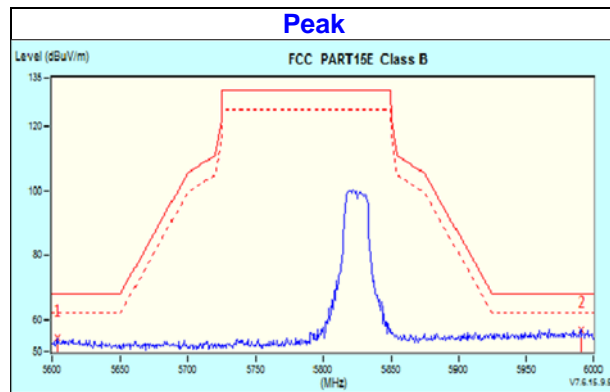

802.11n (HT20)

CHANNEL	TX Channel 36	DETECTOR FUNCTION	Peak (PK) Average (AV)
FREQUENCY RANGE	1GHz ~ 40GHz		

ANTENNA POLARITY & TEST DISTANCE: HORIZONTAL AT 3 M								
NO.	FREQ. (MHz)	EMISSION LEVEL (dBuV/m)	LIMIT (dBuV/m)	MARGIN (dB)	ANTENNA HEIGHT (m)	TABLE ANGLE (Degree)	RAW VALUE (dBuV)	CORRECTION FACTOR (dB/m)
1	5150.00	56.5 PK	74.0	-17.5	2.89 H	102	52.6	3.9
2	5150.00	43.1 AV	54.0	-10.9	2.89 H	102	39.2	3.9
3	*5180.00	95.8 PK			3.81 H	57	56.3	39.5
4	*5180.00	86.2 AV			3.81 H	57	46.7	39.5
5	#10360.00	58.8 PK	68.2	-9.4	1.24 H	58	43.0	15.8

Remarks:

1. Emission Level(dBuV/m) = Raw Value(dBuV) + Correction Factor(dB/m)
2. Correction Factor(dB/m) = Antenna Factor(dB/m) + Cable Factor(dB) – Pre-Amplifier Factor(dB)
3. The other emission levels were very low against the limit
4. Margin value = Emission Level – Limit value
5. " * ": Fundamental frequency
6. " # ": The radiated frequency is out of the restricted band.

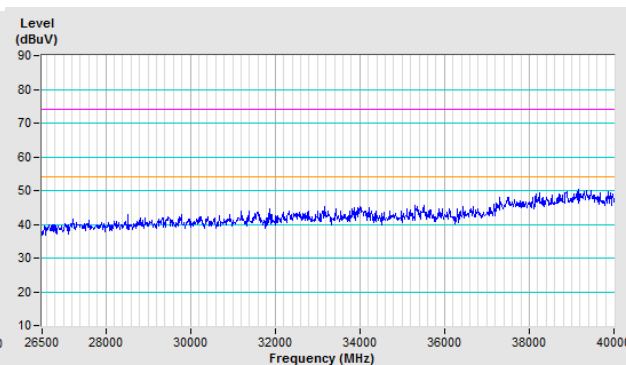
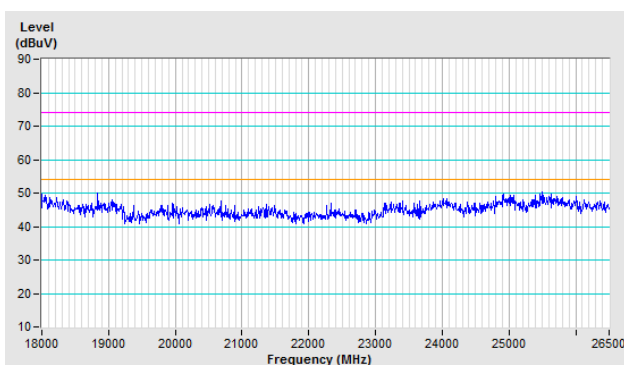
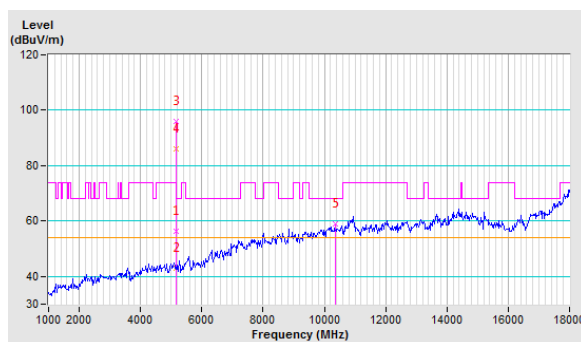

For Bandedge

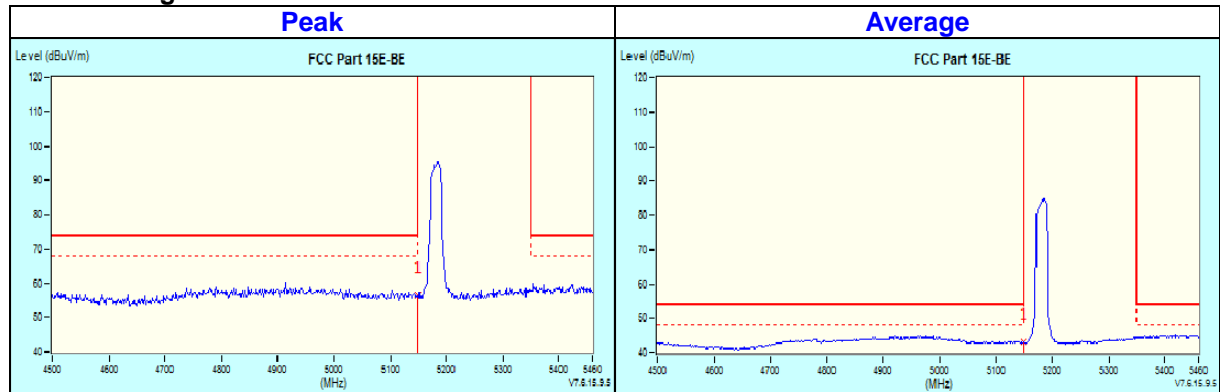

CHANNEL	TX Channel 36	DETECTOR FUNCTION	Peak (PK) Average (AV)
FREQUENCY RANGE	1GHz ~ 40GHz		

ANTENNA POLARITY & TEST DISTANCE: VERTICAL AT 3 M								
NO.	FREQ. (MHz)	EMISSION LEVEL (dBuV/m)	LIMIT (dBuV/m)	MARGIN (dB)	ANTENNA HEIGHT (m)	TABLE ANGLE (Degree)	RAW VALUE (dBuV)	CORRECTION FACTOR (dB/m)
1	5150.00	55.9 PK	74.0	-18.1	1.48 V	53	52.0	3.9
2	5150.00	43.4 AV	54.0	-10.6	1.48 V	53	39.5	3.9
3	*5180.00	103.0 PK			1.21 V	41	63.5	39.5
4	*5180.00	92.8 AV			1.21 V	41	53.3	39.5
5	#10360.00	64.0 PK	68.2	-4.2	1.68 V	325	48.2	15.8

Remarks:

1. Emission Level(dBuV/m) = Raw Value(dBuV) + Correction Factor(dB/m)
2. Correction Factor(dB/m) = Antenna Factor(dB/m) + Cable Factor(dB) – Pre-Amplifier Factor(dB)
3. The other emission levels were very low against the limit
4. Margin value = Emission Level – Limit value
5. " * ": Fundamental frequency
6. " # ": The radiated frequency is out of the restricted band.

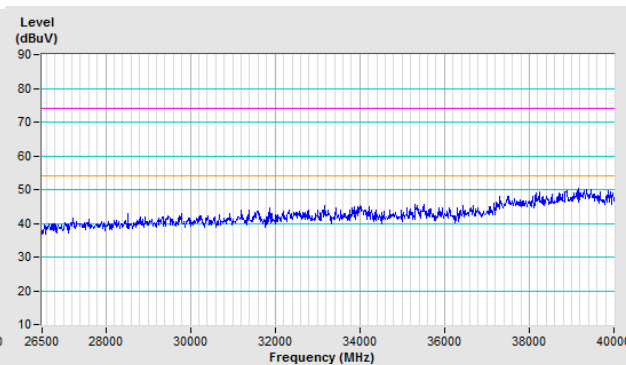
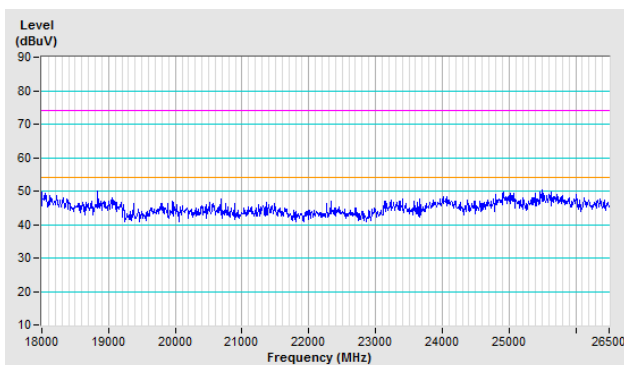
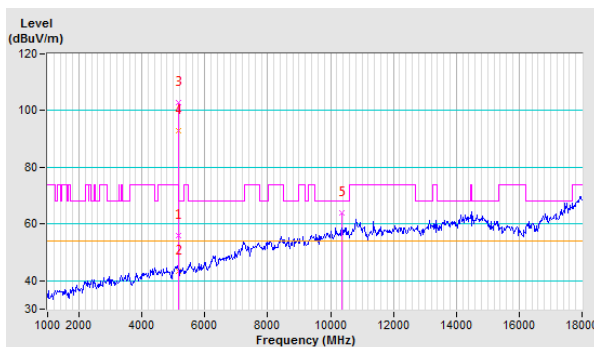

For Bandedge

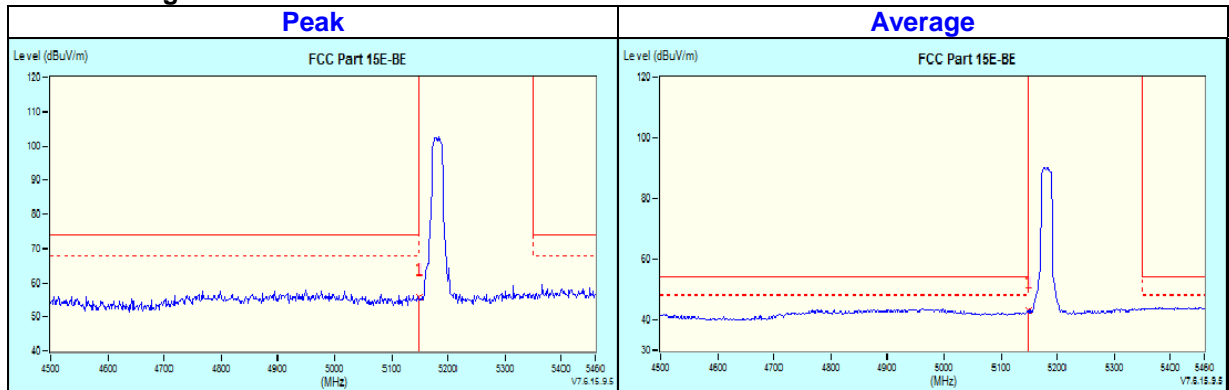

CHANNEL	TX Channel 44	DETECTOR FUNCTION	Peak (PK)
FREQUENCY RANGE	1GHz ~ 40GHz		Average (AV)

ANTENNA POLARITY & TEST DISTANCE: HORIZONTAL AT 3 M								
NO.	FREQ. (MHz)	EMISSION LEVEL (dBuV/m)	LIMIT (dBuV/m)	MARGIN (dB)	ANTENNA HEIGHT (m)	TABLE ANGLE (Degree)	RAW VALUE (dBuV)	CORRECTION FACTOR (dB/m)
1	5150.00	56.1 PK	74.0	-17.9	3.51 H	69	52.2	3.9
2	5150.00	42.7 AV	54.0	-11.3	3.51 H	69	38.8	3.9
3	*5220.00	96.4 PK			3.76 H	57	57.0	39.4
4	*5220.00	86.2 AV			3.76 H	57	46.8	39.4
5	#10440.00	62.1 PK	68.2	-6.1	1.11 H	56	45.6	16.5

Remarks:

1. Emission Level(dBuV/m) = Raw Value(dBuV) + Correction Factor(dB/m)
2. Correction Factor(dB/m) = Antenna Factor(dB/m) + Cable Factor(dB) – Pre-Amplifier Factor(dB)
3. The other emission levels were very low against the limit
4. Margin value = Emission Level – Limit value
5. " * ": Fundamental frequency
6. " # ": The radiated frequency is out of the restricted band.

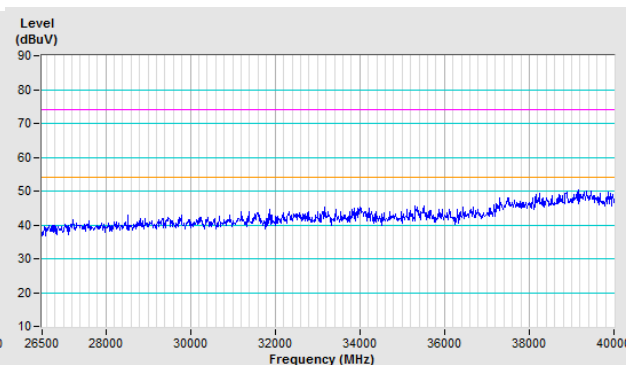
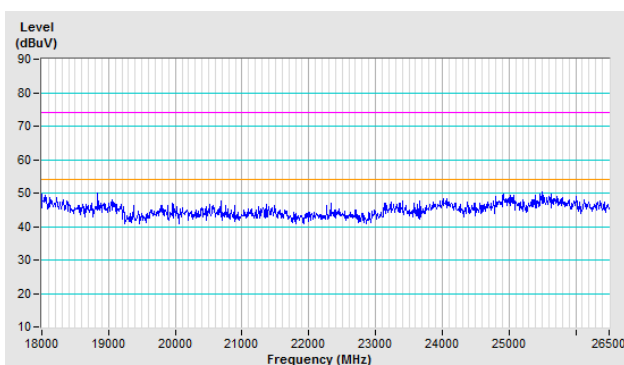
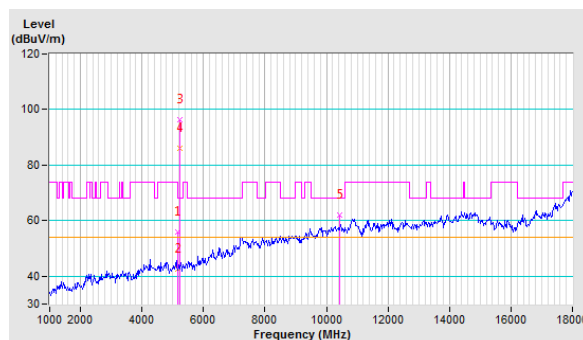

For Bandedge

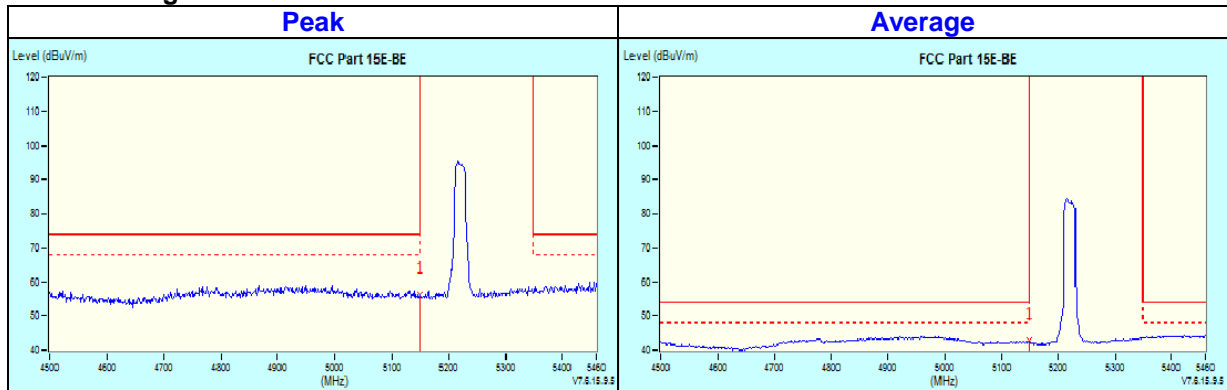

CHANNEL	TX Channel 44	DETECTOR FUNCTION	Peak (PK)
FREQUENCY RANGE	1GHz ~ 40GHz		Average (AV)

ANTENNA POLARITY & TEST DISTANCE: VERTICAL AT 3 M								
NO.	FREQ. (MHz)	EMISSION LEVEL (dBuV/m)	LIMIT (dBuV/m)	MARGIN (dB)	ANTENNA HEIGHT (m)	TABLE ANGLE (Degree)	RAW VALUE (dBuV)	CORRECTION FACTOR (dB/m)
1	5150.00	56.1 PK	74.0	-17.9	1.23 V	55	52.2	3.9
2	5150.00	43.0 AV	54.0	-11.0	1.23 V	55	39.1	3.9
3	*5220.00	103.4 PK			1.13 V	44	64.0	39.4
4	*5220.00	93.2 AV			1.13 V	44	53.8	39.4
5	#10440.00	64.9 PK	68.2	-3.3	1.79 V	14	48.4	16.5

Remarks:

1. Emission Level(dBuV/m) = Raw Value(dBuV) + Correction Factor(dB/m)
2. Correction Factor(dB/m) = Antenna Factor(dB/m) + Cable Factor(dB) – Pre-Amplifier Factor(dB)
3. The other emission levels were very low against the limit
4. Margin value = Emission Level – Limit value
5. " * ": Fundamental frequency
6. " # ": The radiated frequency is out of the restricted band.

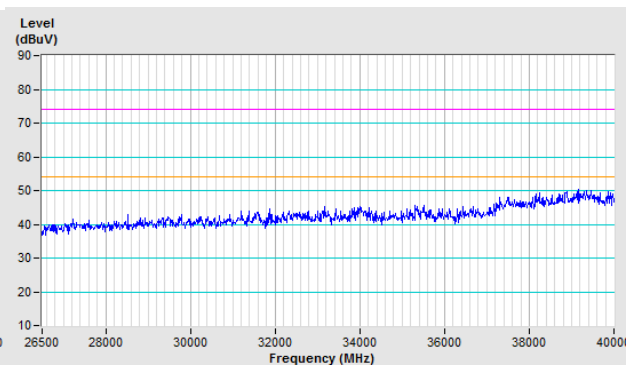
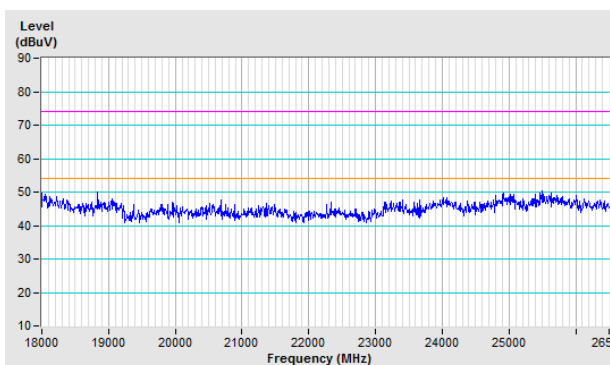
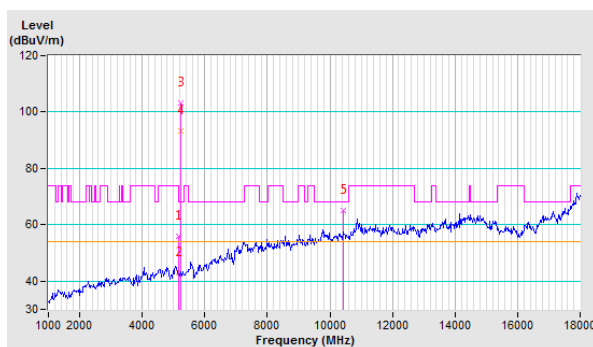

For Bandedge

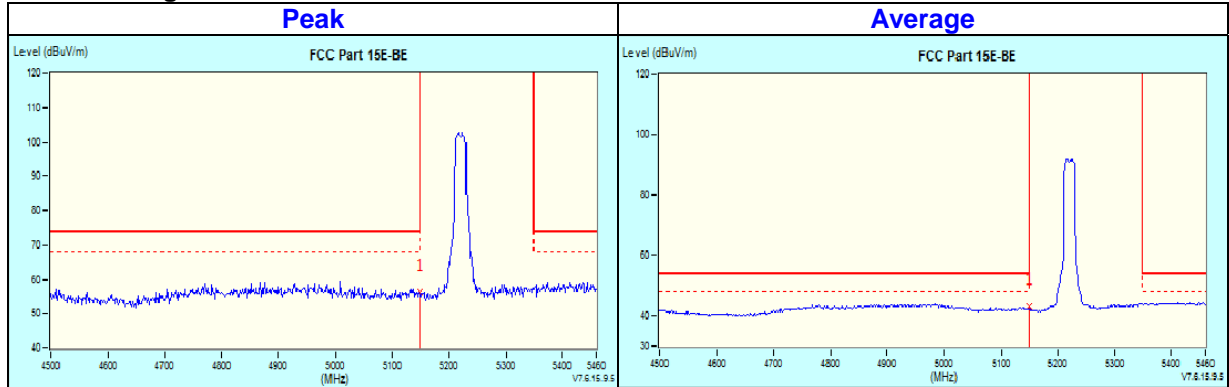

CHANNEL	TX Channel 48	DETECTOR FUNCTION	Peak (PK)
FREQUENCY RANGE	1GHz ~ 40GHz		Average (AV)

ANTENNA POLARITY & TEST DISTANCE: HORIZONTAL AT 3 M								
NO.	FREQ. (MHz)	EMISSION LEVEL (dBuV/m)	LIMIT (dBuV/m)	MARGIN (dB)	ANTENNA HEIGHT (m)	TABLE ANGLE (Degree)	RAW VALUE (dBuV)	CORRECTION FACTOR (dB/m)
1	*5240.00	95.8 PK			3.54 H	330	56.5	39.3
2	*5240.00	85.8 AV			3.54 H	330	46.5	39.3
3	5350.00	56.8 PK	74.0	-17.2	3.16 H	298	52.9	3.9
4	5350.00	42.9 AV	54.0	-11.1	3.16 H	298	39.0	3.9
5	#10480.00	64.8 PK	68.2	-3.4	3.27 H	62	48.0	16.8

Remarks:

1. Emission Level(dBuV/m) = Raw Value(dBuV) + Correction Factor(dB/m)
2. Correction Factor(dB/m) = Antenna Factor(dB/m) + Cable Factor(dB) – Pre-Amplifier Factor(dB)
3. The other emission levels were very low against the limit
4. Margin value = Emission Level – Limit value
5. " * ": Fundamental frequency
6. " # ": The radiated frequency is out of the restricted band.

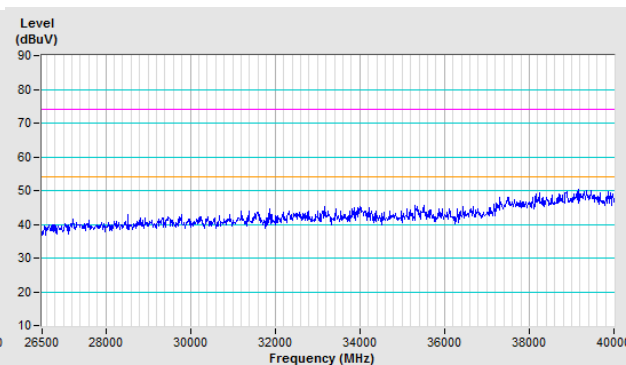
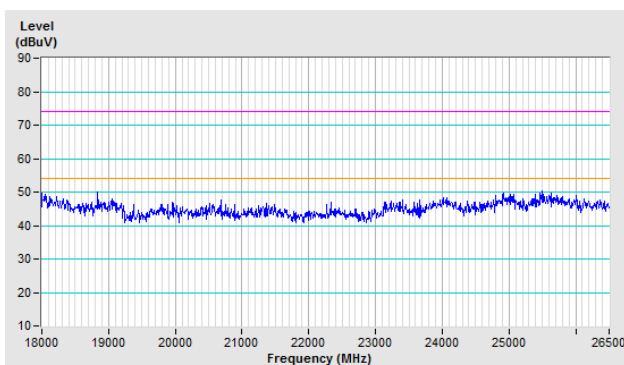
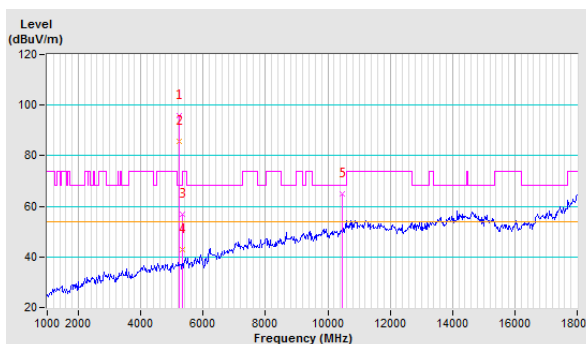

For Bandedge

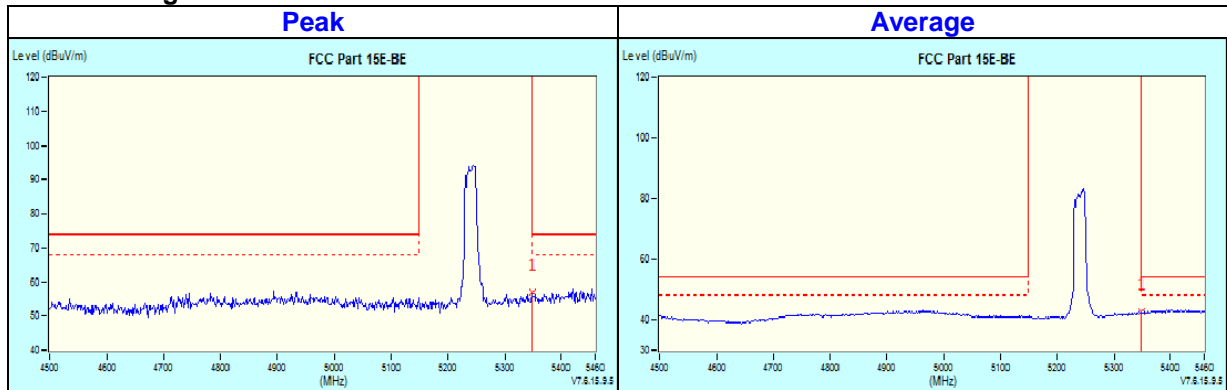

CHANNEL	TX Channel 48	DETECTOR FUNCTION	Peak (PK)
FREQUENCY RANGE	1GHz ~ 40GHz		Average (AV)

ANTENNA POLARITY & TEST DISTANCE: VERTICAL AT 3 M								
NO.	FREQ. (MHz)	EMISSION LEVEL (dBuV/m)	LIMIT (dBuV/m)	MARGIN (dB)	ANTENNA HEIGHT (m)	TABLE ANGLE (Degree)	RAW VALUE (dBuV)	CORRECTION FACTOR (dB/m)
1	*5240.00	102.8 PK			1.20 V	36	63.5	39.3
2	*5240.00	92.8 AV			1.20 V	36	53.5	39.3
3	5350.00	57.2 PK	74.0	-16.8	1.26 V	41	53.3	3.9
4	5350.00	43.5 AV	54.0	-10.5	1.26 V	41	39.6	3.9
5	#10480.00	65.0 PK	68.2	-3.2	1.61 V	331	48.2	16.8

Remarks:

1. Emission Level(dBuV/m) = Raw Value(dBuV) + Correction Factor(dB/m)
2. Correction Factor(dB/m) = Antenna Factor(dB/m) + Cable Factor(dB) – Pre-Amplifier Factor(dB)
3. The other emission levels were very low against the limit
4. Margin value = Emission Level – Limit value
5. " * ": Fundamental frequency
6. " # ": The radiated frequency is out of the restricted band.

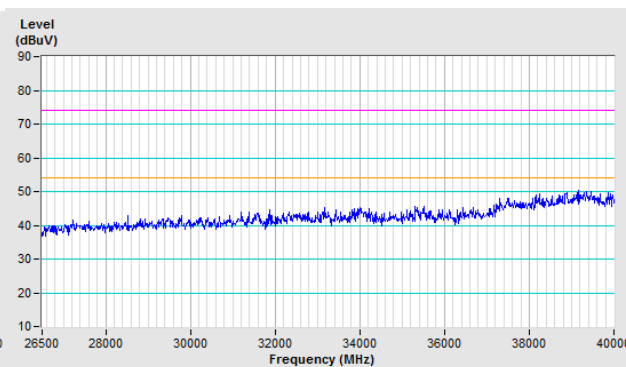
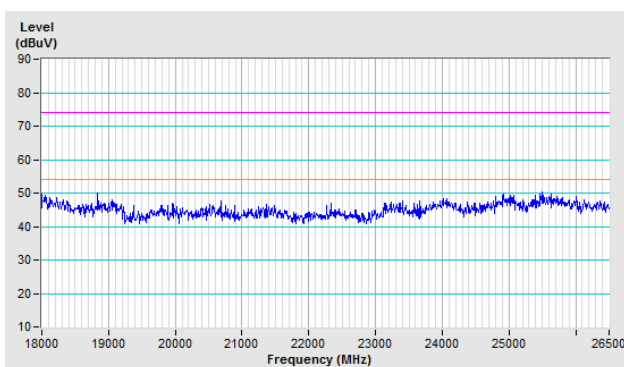
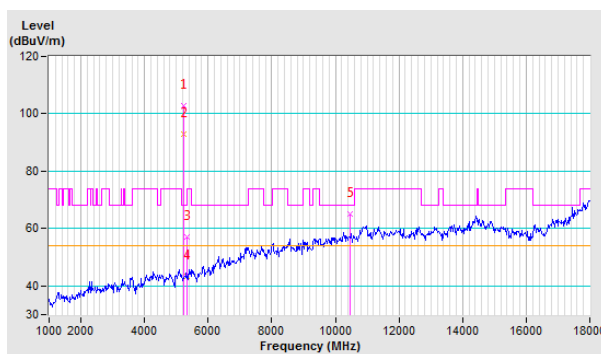

For Bandedge

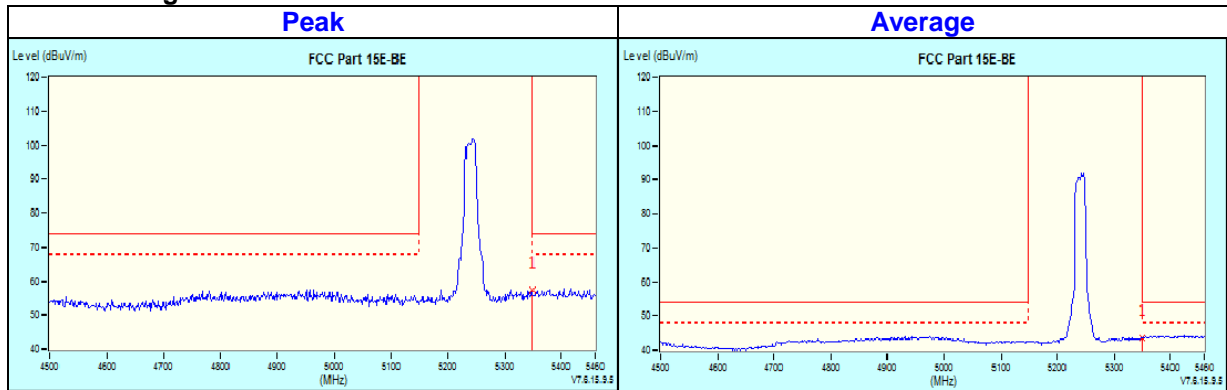

CHANNEL	TX Channel 52	DETECTOR FUNCTION	Peak (PK)
FREQUENCY RANGE	1GHz ~ 40GHz		Average (AV)

ANTENNA POLARITY & TEST DISTANCE: HORIZONTAL AT 3 M								
NO.	FREQ. (MHz)	EMISSION LEVEL (dBuV/m)	LIMIT (dBuV/m)	MARGIN (dB)	ANTENNA HEIGHT (m)	TABLE ANGLE (Degree)	RAW VALUE (dBuV)	CORRECTION FACTOR (dB/m)
1	5150.00	55.4 PK	74.0	-18.6	3.51 H	324	51.5	3.9
2	5150.00	43.2 AV	54.0	-10.8	3.51 H	324	39.3	3.9
3	*5260.00	94.5 PK			3.69 H	341	55.2	39.3
4	*5260.00	85.0 AV			3.69 H	341	45.7	39.3
5	#10520.00	61.5 PK	68.2	-6.7	2.31 H	303	44.6	16.9

Remarks:

1. Emission Level(dBuV/m) = Raw Value(dBuV) + Correction Factor(dB/m)
2. Correction Factor(dB/m) = Antenna Factor(dB/m) + Cable Factor(dB) – Pre-Amplifier Factor(dB)
3. The other emission levels were very low against the limit
4. Margin value = Emission Level – Limit value
5. " * ": Fundamental frequency
6. " # ": The radiated frequency is out of the restricted band.

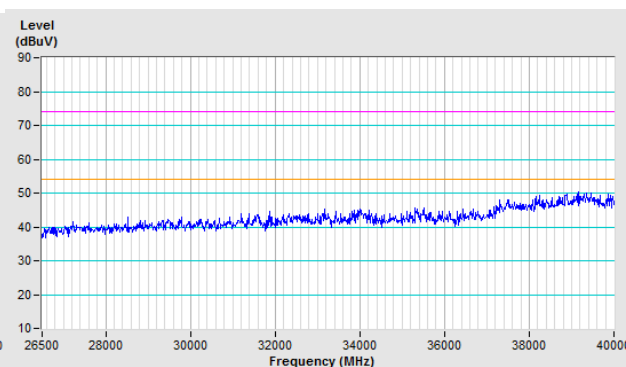
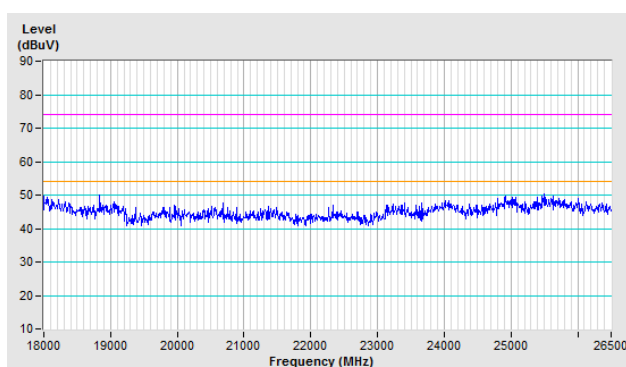
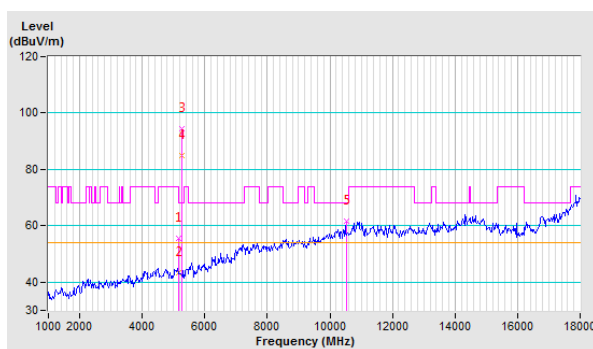

For Bandedge

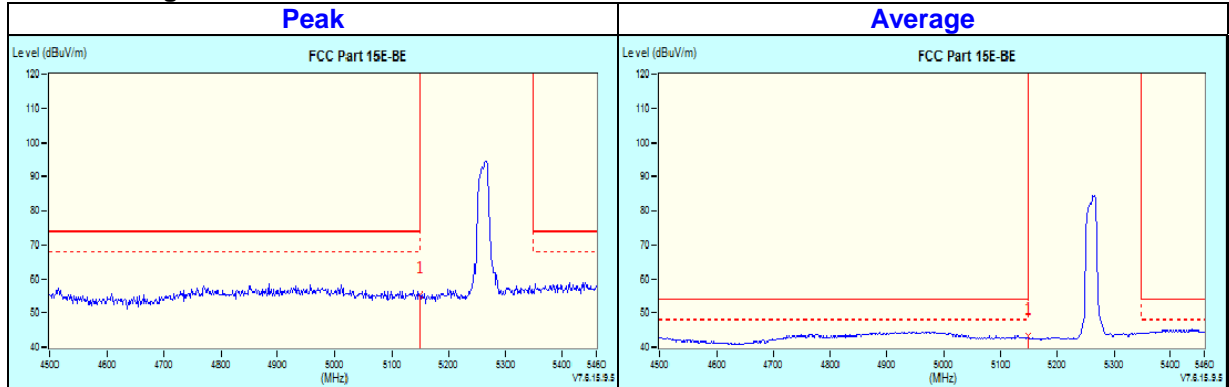

CHANNEL	TX Channel 52	DETECTOR FUNCTION	Peak (PK) Average (AV)
FREQUENCY RANGE	1GHz ~ 40GHz		

ANTENNA POLARITY & TEST DISTANCE: VERTICAL AT 3 M								
NO.	FREQ. (MHz)	EMISSION LEVEL (dBuV/m)	LIMIT (dBuV/m)	MARGIN (dB)	ANTENNA HEIGHT (m)	TABLE ANGLE (Degree)	RAW VALUE (dBuV)	CORRECTION FACTOR (dB/m)
1	5150.00	55.8 PK	74.0	-18.2	1.64 V	121	51.9	3.9
2	5150.00	42.9 AV	54.0	-11.1	1.64 V	121	39.0	3.9
3	*5260.00	103.6 PK			1.16 V	45	64.3	39.3
4	*5260.00	93.4 AV			1.16 V	45	54.1	39.3
5	#10520.00	65.1 PK	68.2	-3.1	3.51 V	4	48.2	16.9

Remarks:

1. Emission Level(dBuV/m) = Raw Value(dBuV) + Correction Factor(dB/m)
2. Correction Factor(dB/m) = Antenna Factor(dB/m) + Cable Factor(dB) – Pre-Amplifier Factor(dB)
3. The other emission levels were very low against the limit
4. Margin value = Emission Level – Limit value
5. " * ": Fundamental frequency
6. " # ": The radiated frequency is out of the restricted band.

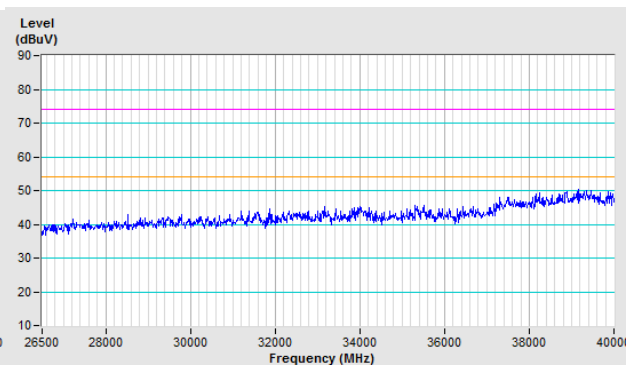
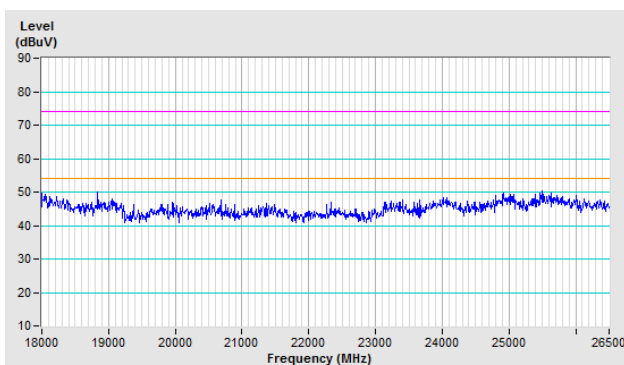
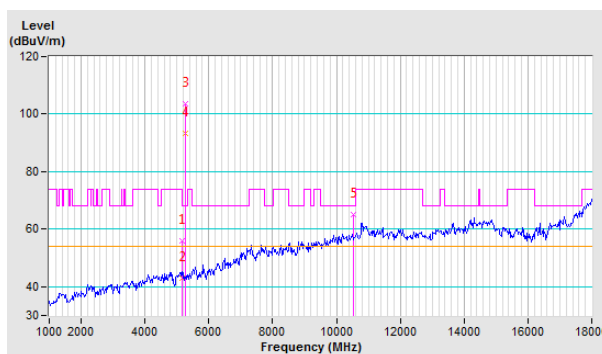

For Bandedge

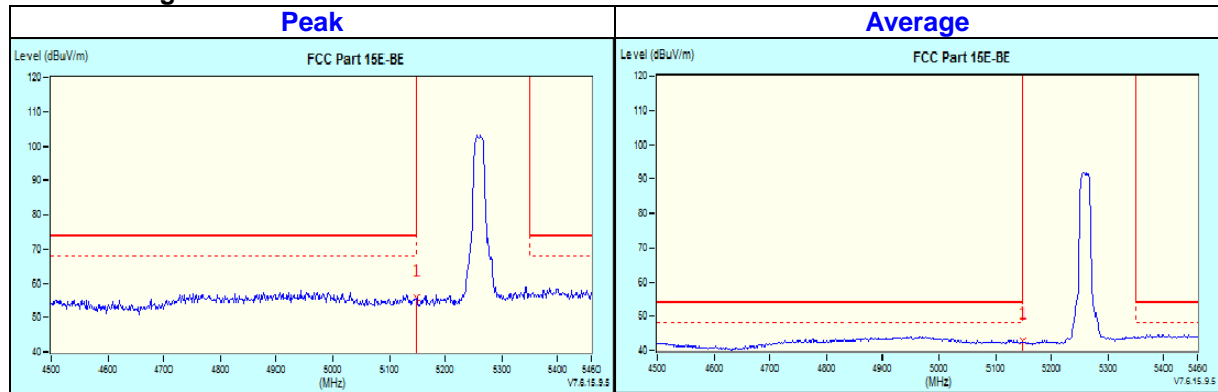

CHANNEL	TX Channel 60	DETECTOR FUNCTION	Peak (PK)
FREQUENCY RANGE	1GHz ~ 40GHz		Average (AV)

ANTENNA POLARITY & TEST DISTANCE: HORIZONTAL AT 3 M								
NO.	FREQ. (MHz)	EMISSION LEVEL (dBuV/m)	LIMIT (dBuV/m)	MARGIN (dB)	ANTENNA HEIGHT (m)	TABLE ANGLE (Degree)	RAW VALUE (dBuV)	CORRECTION FACTOR (dB/m)
1	*5300.00	97.4 PK			3.66 H	344	58.1	39.3
2	*5300.00	87.7 AV			3.66 H	344	48.4	39.3
3	5350.00	56.0 PK	74.0	-18.0	3.25 H	302	52.1	3.9
4	5350.00	42.9 AV	54.0	-11.1	3.25 H	302	39.0	3.9
5	10600.00	66.2 PK	74.0	-7.8	1.05 H	56	49.2	17.0
6	10600.00	51.0 AV	54.0	-3.0	1.05 H	56	34.0	17.0

Remarks:

1. Emission Level(dBuV/m) = Raw Value(dBuV) + Correction Factor(dB/m)
2. Correction Factor(dB/m) = Antenna Factor(dB/m) + Cable Factor(dB) – Pre-Amplifier Factor(dB)
3. The other emission levels were very low against the limit
4. Margin value = Emission Level – Limit value
5. " * ": Fundamental frequency

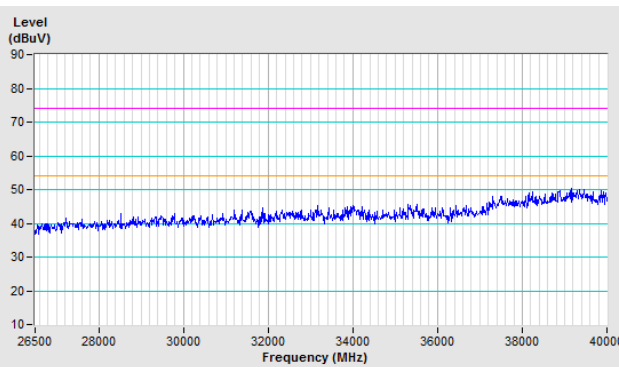
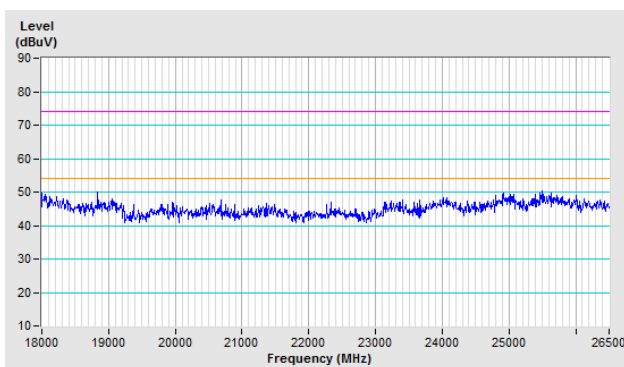
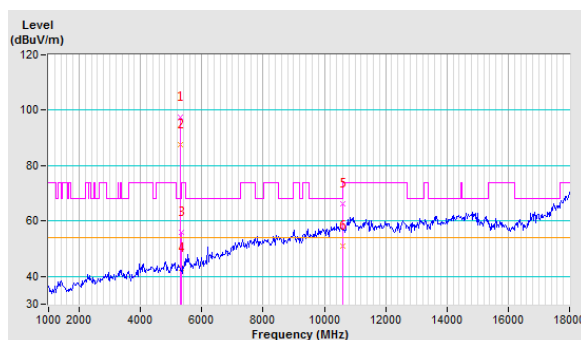

For Bandedge

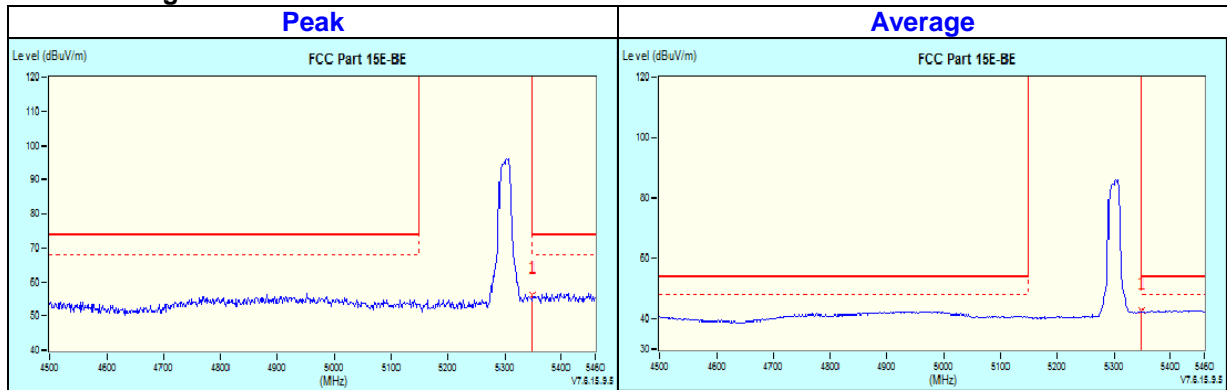

CHANNEL	TX Channel 60	DETECTOR FUNCTION	Peak (PK)
FREQUENCY RANGE	1GHz ~ 40GHz		Average (AV)

ANTENNA POLARITY & TEST DISTANCE: VERTICAL AT 3 M								
NO.	FREQ. (MHz)	EMISSION LEVEL (dBuV/m)	LIMIT (dBuV/m)	MARGIN (dB)	ANTENNA HEIGHT (m)	TABLE ANGLE (Degree)	RAW VALUE (dBuV)	CORRECTION FACTOR (dB/m)
1	*5300.00	102.6 PK			1.08 V	51	63.3	39.3
2	*5300.00	92.5 AV			1.08 V	51	53.2	39.3
3	5350.00	57.0 PK	74.0	-17.0	1.48 V	62	53.1	3.9
4	5350.00	43.5 AV	54.0	-10.5	1.48 V	62	39.6	3.9
5	10600.00	65.1 PK	74.0	-8.9	1.39 V	348	48.1	17.0
6	10600.00	49.8 AV	54.0	-4.2	1.39 V	348	32.8	17.0

Remarks:

1. Emission Level(dBuV/m) = Raw Value(dBuV) + Correction Factor(dB/m)
2. Correction Factor(dB/m) = Antenna Factor(dB/m) + Cable Factor(dB) – Pre-Amplifier Factor(dB)
3. The other emission levels were very low against the limit
4. Margin value = Emission Level – Limit value
5. " * ": Fundamental frequency

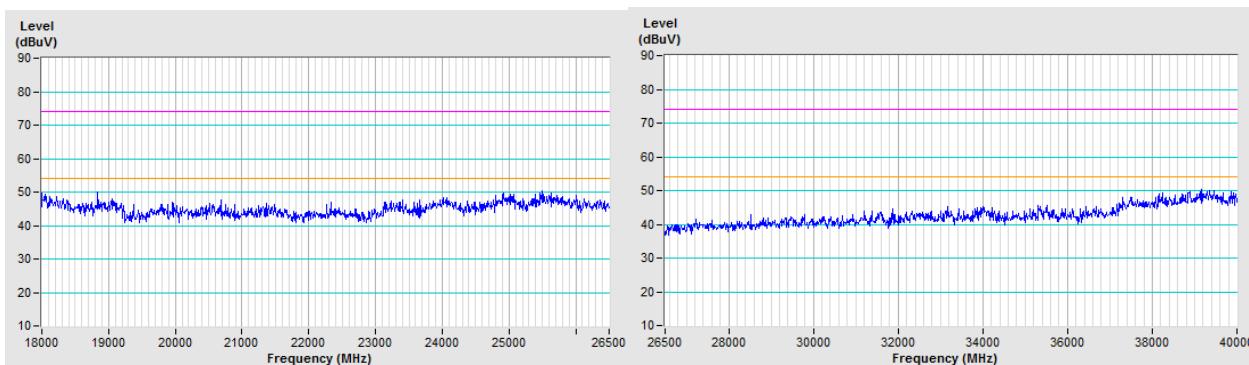
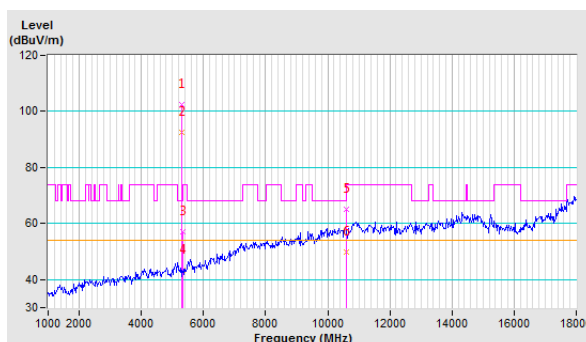

For Bandedge

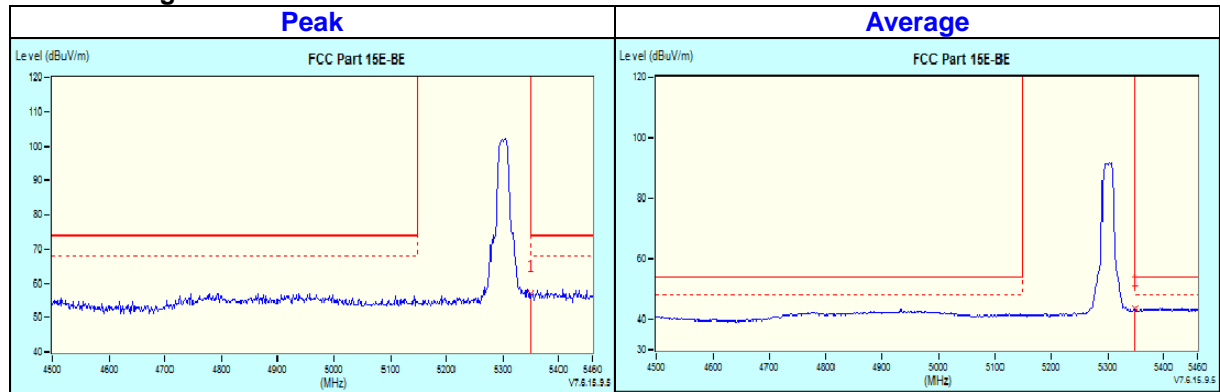

CHANNEL	TX Channel 64	DETECTOR FUNCTION	Peak (PK)
FREQUENCY RANGE	1GHz ~ 40GHz		Average (AV)

ANTENNA POLARITY & TEST DISTANCE: HORIZONTAL AT 3 M								
NO.	FREQ. (MHz)	EMISSION LEVEL (dBuV/m)	LIMIT (dBuV/m)	MARGIN (dB)	ANTENNA HEIGHT (m)	TABLE ANGLE (Degree)	RAW VALUE (dBuV)	CORRECTION FACTOR (dB/m)
1	*5320.00	97.7 PK			3.67 H	355	58.4	39.3
2	*5320.00	87.9 AV			3.67 H	355	48.6	39.3
3	5350.00	56.3 PK	74.0	-17.7	3.51 H	310	52.4	3.9
4	5350.00	43.1 AV	54.0	-10.9	3.51 H	310	39.2	3.9
5	10640.00	66.6 PK	74.0	-7.4	1.13 H	54	49.6	17.0
6	10640.00	50.9 AV	54.0	-3.1	1.13 H	54	33.9	17.0

Remarks:

1. Emission Level(dBuV/m) = Raw Value(dBuV) + Correction Factor(dB/m)
2. Correction Factor(dB/m) = Antenna Factor(dB/m) + Cable Factor(dB) – Pre-Amplifier Factor(dB)
3. The other emission levels were very low against the limit
4. Margin value = Emission Level – Limit value
5. " * ": Fundamental frequency

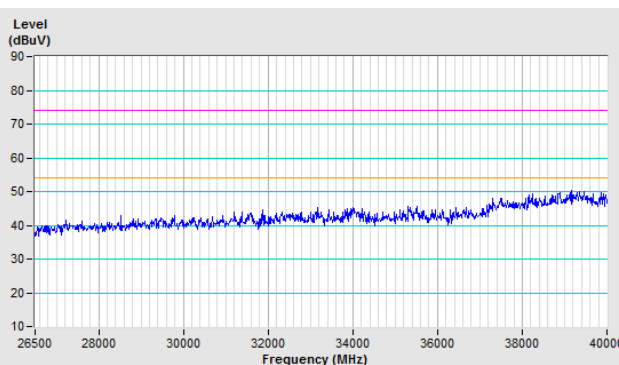
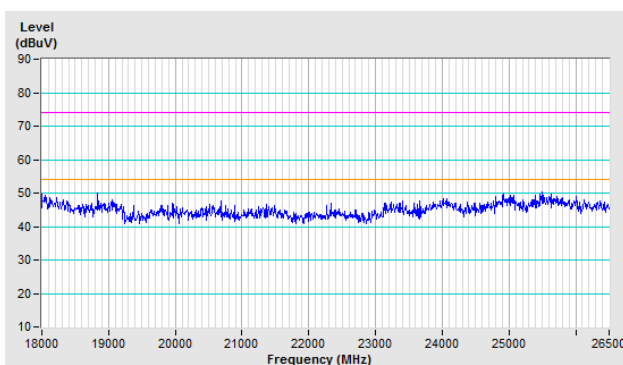
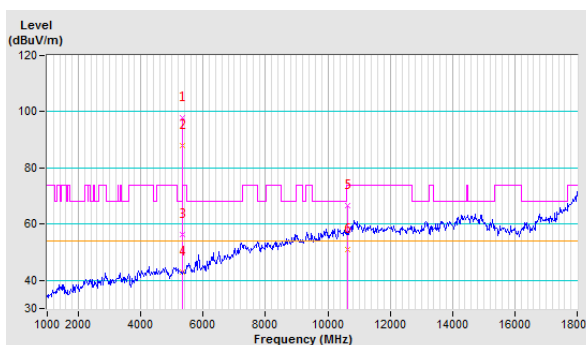

For Bandedge

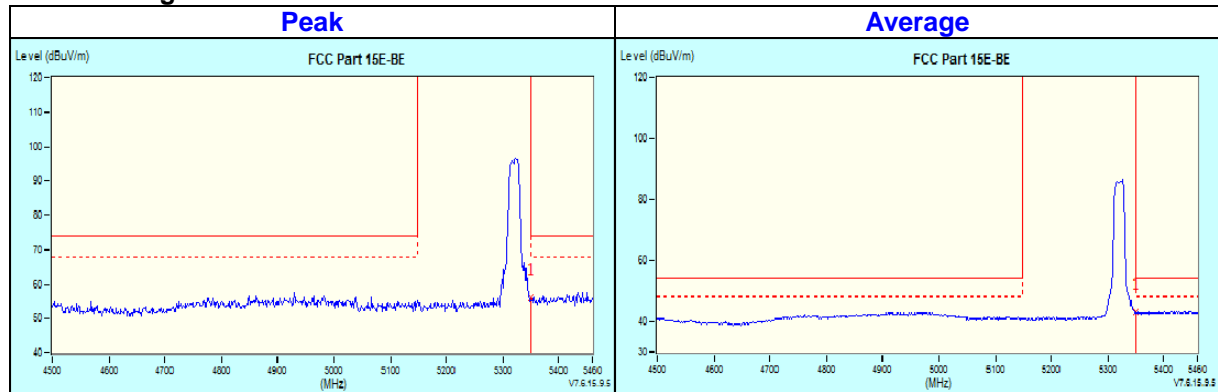

CHANNEL	TX Channel 64	DETECTOR FUNCTION	Peak (PK) Average (AV)
FREQUENCY RANGE	1GHz ~ 40GHz		

ANTENNA POLARITY & TEST DISTANCE: VERTICAL AT 3 M								
NO.	FREQ. (MHz)	EMISSION LEVEL (dBuV/m)	LIMIT (dBuV/m)	MARGIN (dB)	ANTENNA HEIGHT (m)	TABLE ANGLE (Degree)	RAW VALUE (dBuV)	CORRECTION FACTOR (dB/m)
1	*5320.00	102.3 PK			1.01 V	58	63.0	39.3
2	*5320.00	92.1 AV			1.01 V	58	52.8	39.3
3	5350.00	56.5 PK	74.0	-17.5	1.35 V	44	52.6	3.9
4	5350.00	43.7 AV	54.0	-10.3	1.35 V	44	39.8	3.9
5	10640.00	65.1 PK	74.0	-8.9	1.49 V	342	48.1	17.0
6	10640.00	49.9 AV	54.0	-4.1	1.49 V	342	32.9	17.0

Remarks:

1. Emission Level(dBuV/m) = Raw Value(dBuV) + Correction Factor(dB/m)
2. Correction Factor(dB/m) = Antenna Factor(dB/m) + Cable Factor(dB) – Pre-Amplifier Factor(dB)
3. The other emission levels were very low against the limit
4. Margin value = Emission Level – Limit value
5. " * ": Fundamental frequency

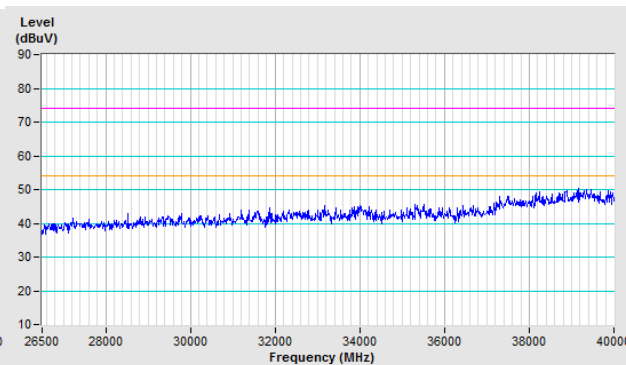
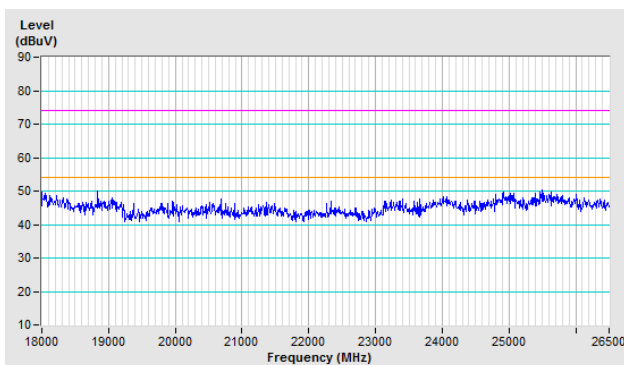
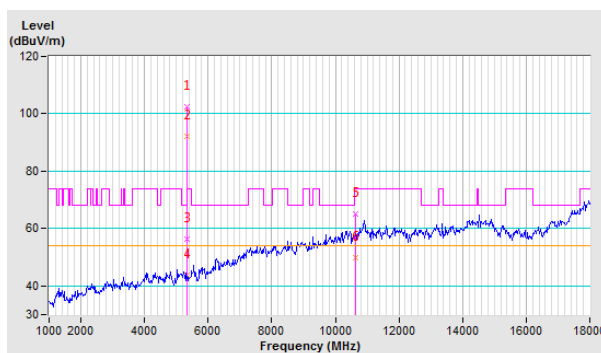

For Bandedge

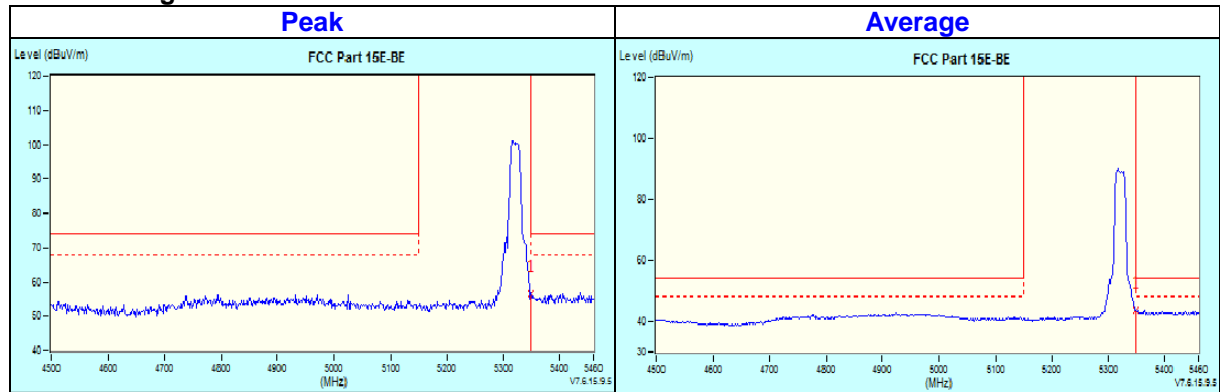

CHANNEL	TX Channel 100	DETECTOR FUNCTION	Peak (PK)
FREQUENCY RANGE	1GHz ~ 40GHz		Average (AV)

ANTENNA POLARITY & TEST DISTANCE: HORIZONTAL AT 3 M								
NO.	FREQ. (MHz)	EMISSION LEVEL (dBuV/m)	LIMIT (dBuV/m)	MARGIN (dB)	ANTENNA HEIGHT (m)	TABLE ANGLE (Degree)	RAW VALUE (dBuV)	CORRECTION FACTOR (dB/m)
1	5460.00	56.2 PK	74.0	-17.8	1.05 H	284	52.1	4.1
2	5460.00	42.7 AV	54.0	-11.3	1.05 H	284	38.6	4.1
3	#5470.00	57.3 PK	68.2	-10.9	1.26 H	313	53.2	4.1
4	*5500.00	96.0 PK			1.46 H	309	56.2	39.8
5	*5500.00	86.0 AV			1.46 H	309	46.2	39.8
6	11000.00	60.3 PK	74.0	-13.7	1.32 H	69	41.9	18.4
7	11000.00	47.8 AV	54.0	-6.2	1.32 H	69	29.4	18.4

Remarks:

1. Emission Level(dBuV/m) = Raw Value(dBuV) + Correction Factor(dB/m)
2. Correction Factor(dB/m) = Antenna Factor(dB/m) + Cable Factor(dB) – Pre-Amplifier Factor(dB)
3. The other emission levels were very low against the limit
4. Margin value = Emission Level – Limit value
5. " * ": Fundamental frequency

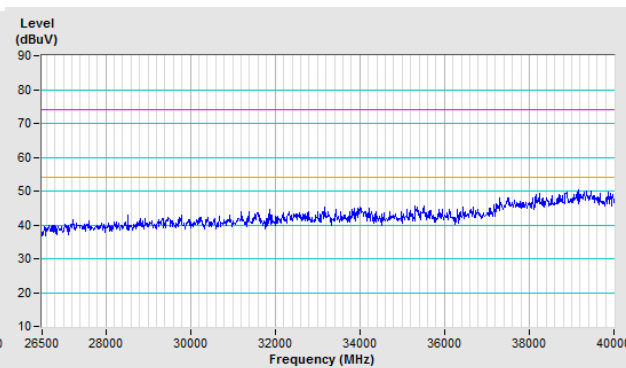
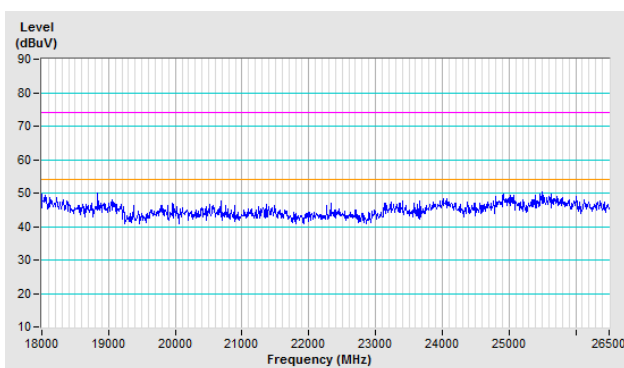
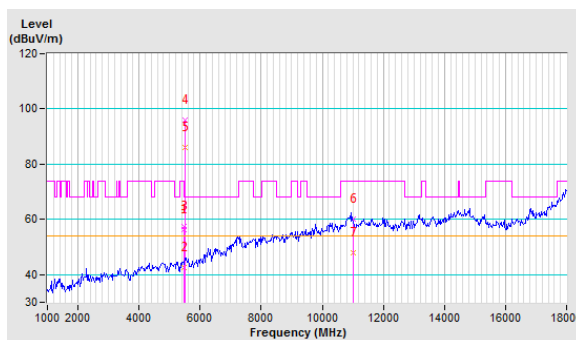

For Bandedge

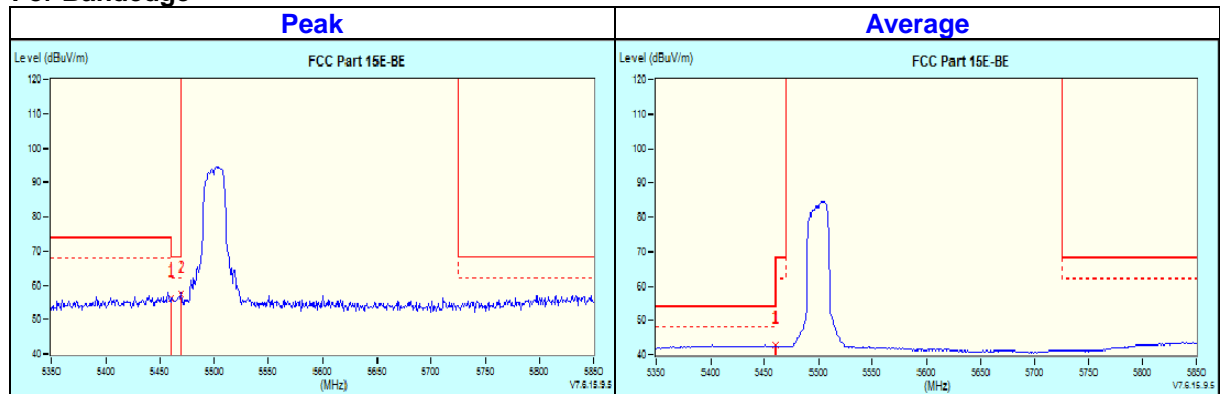

CHANNEL	TX Channel 100	DETECTOR FUNCTION	Peak (PK)
FREQUENCY RANGE	1GHz ~ 40GHz		Average (AV)

ANTENNA POLARITY & TEST DISTANCE: VERTICAL AT 3 M								
NO.	FREQ. (MHz)	EMISSION LEVEL (dBuV/m)	LIMIT (dBuV/m)	MARGIN (dB)	ANTENNA HEIGHT (m)	TABLE ANGLE (Degree)	RAW VALUE (dBuV)	CORRECTION FACTOR (dB/m)
1	5460.00	55.4 PK	74.0	-18.6	2.76 V	322	51.3	4.1
2	5460.00	42.7 AV	54.0	-11.3	2.76 V	322	38.6	4.1
3	#5470.00	57.2 PK	68.2	-11.0	2.15 V	264	53.1	4.1
4	*5500.00	100.6 PK			2.63 V	315	60.8	39.8
5	*5500.00	90.6 AV			2.63 V	315	50.8	39.8
6	11000.00	60.2 PK	74.0	-13.8	1.52 V	329	41.8	18.4
7	11000.00	47.0 AV	54.0	-7.0	1.52 V	329	28.6	18.4

Remarks:

1. Emission Level(dBuV/m) = Raw Value(dBuV) + Correction Factor(dB/m)
2. Correction Factor(dB/m) = Antenna Factor(dB/m) + Cable Factor(dB) – Pre-Amplifier Factor(dB)
3. The other emission levels were very low against the limit
4. Margin value = Emission Level – Limit value
5. " * ": Fundamental frequency

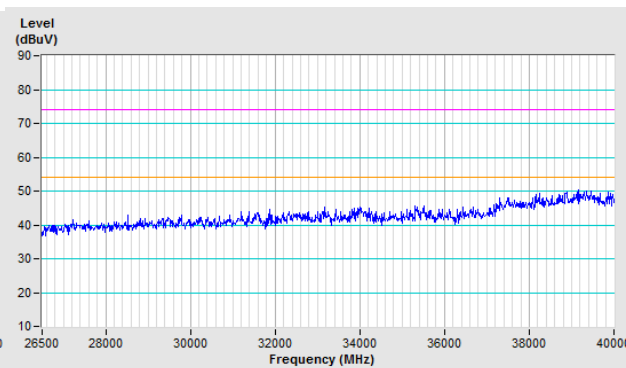
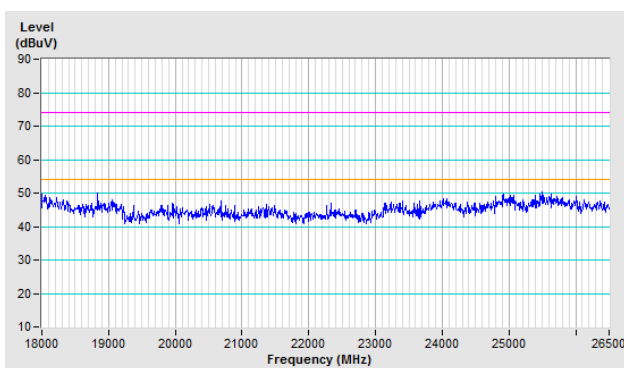
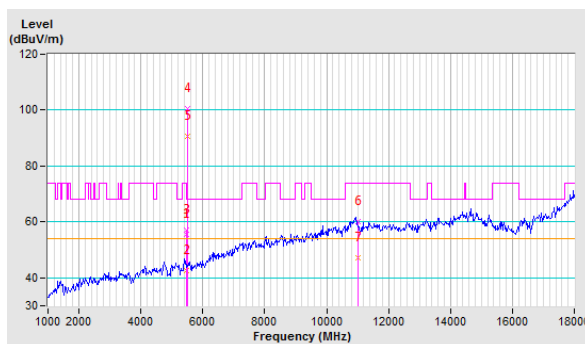

For Bandedge

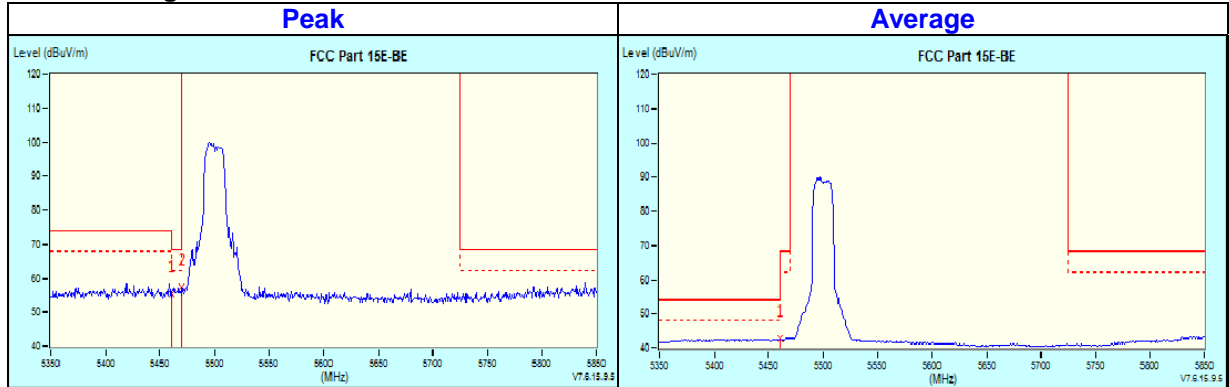

CHANNEL	TX Channel 116	DETECTOR FUNCTION	Peak (PK)
FREQUENCY RANGE	1GHz ~ 40GHz		Average (AV)

ANTENNA POLARITY & TEST DISTANCE: HORIZONTAL AT 3 M								
NO.	FREQ. (MHz)	EMISSION LEVEL (dBuV/m)	LIMIT (dBuV/m)	MARGIN (dB)	ANTENNA HEIGHT (m)	TABLE ANGLE (Degree)	RAW VALUE (dBuV)	CORRECTION FACTOR (dB/m)
1	*5580.00	99.4 PK			1.22 H	285	59.6	39.8
2	*5580.00	89.9 AV			1.22 H	285	50.1	39.8
3	#5725.00	56.1 PK	68.2	-12.1	1.83 H	316	51.7	4.4
4	11160.00	63.3 PK	74.0	-10.7	1.00 H	52	45.8	17.5
5	11160.00	49.8 AV	54.0	-4.2	1.00 H	52	32.3	17.5

Remarks:

1. Emission Level(dBuV/m) = Raw Value(dBuV) + Correction Factor(dB/m)
2. Correction Factor(dB/m) = Antenna Factor(dB/m) + Cable Factor(dB) – Pre-Amplifier Factor(dB)
3. The other emission levels were very low against the limit
4. Margin value = Emission Level – Limit value
5. " * ": Fundamental frequency

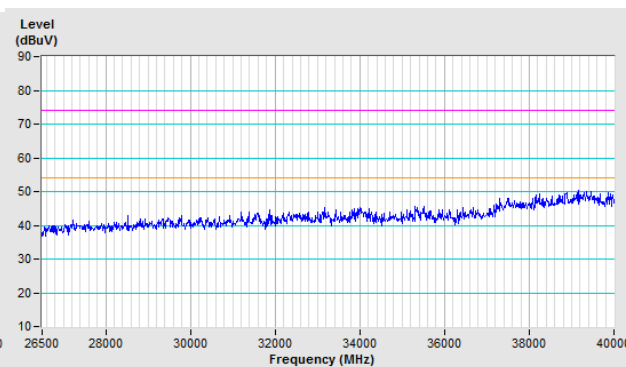
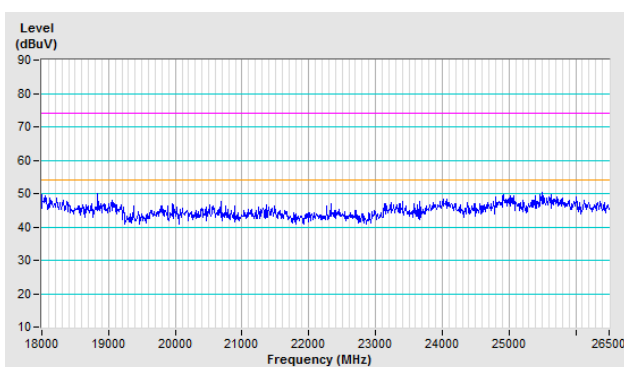
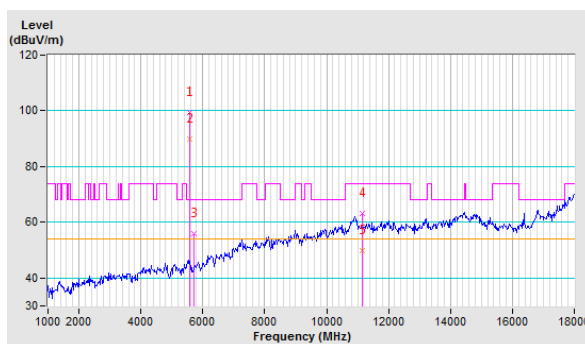

For Bandedge

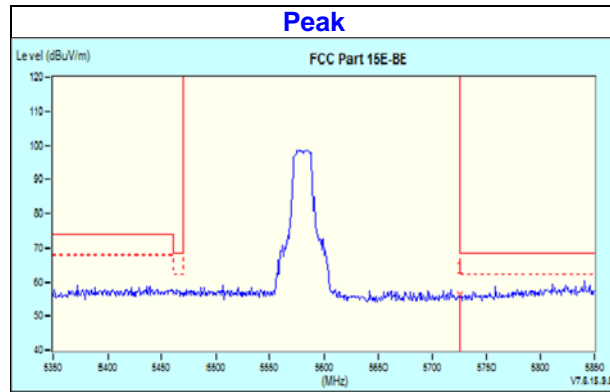

CHANNEL	TX Channel 116	DETECTOR FUNCTION	Peak (PK) Average (AV)
FREQUENCY RANGE	1GHz ~ 40GHz		

ANTENNA POLARITY & TEST DISTANCE: VERTICAL AT 3 M								
NO.	FREQ. (MHz)	EMISSION LEVEL (dBuV/m)	LIMIT (dBuV/m)	MARGIN (dB)	ANTENNA HEIGHT (m)	TABLE ANGLE (Degree)	RAW VALUE (dBuV)	CORRECTION FACTOR (dB/m)
1	*5580.00	102.5 PK			1.09 V	58	62.7	39.8
2	*5580.00	93.0 AV			1.09 V	58	53.2	39.8
3	#5725.00	56.2 PK	68.2	-12.0	1.38 V	92	51.8	4.4
4	11160.00	62.5 PK	74.0	-11.5	1.17 V	311	45.0	17.5
5	11160.00	48.9 AV	54.0	-5.1	1.17 V	311	31.4	17.5

Remarks:

1. Emission Level(dBuV/m) = Raw Value(dBuV) + Correction Factor(dB/m)
2. Correction Factor(dB/m) = Antenna Factor(dB/m) + Cable Factor(dB) – Pre-Amplifier Factor(dB)
3. The other emission levels were very low against the limit
4. Margin value = Emission Level – Limit value
5. " * ": Fundamental frequency

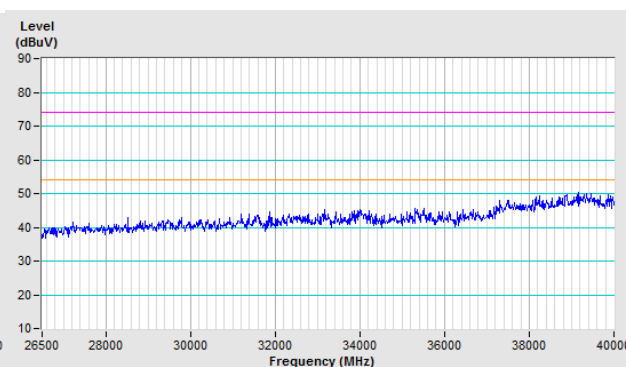
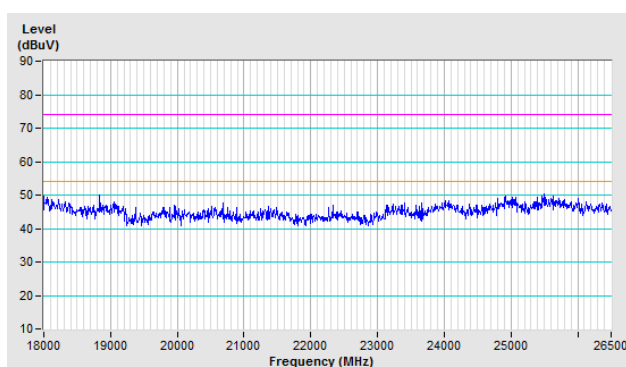
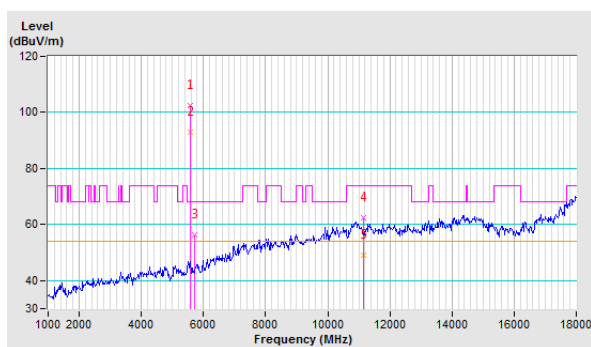

For Bandedge

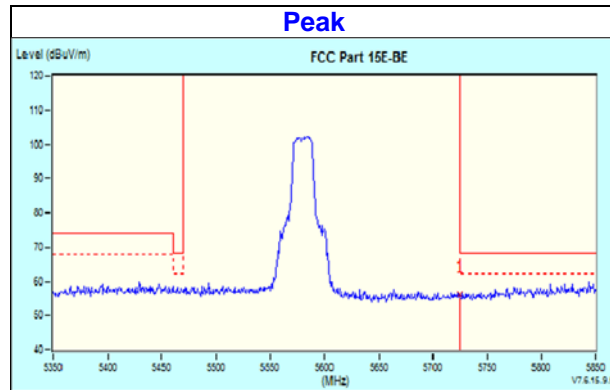

CHANNEL	TX Channel 140	DETECTOR FUNCTION	Peak (PK)
FREQUENCY RANGE	1GHz ~ 40GHz		Average (AV)

ANTENNA POLARITY & TEST DISTANCE: HORIZONTAL AT 3 M								
NO.	FREQ. (MHz)	EMISSION LEVEL (dBuV/m)	LIMIT (dBuV/m)	MARGIN (dB)	ANTENNA HEIGHT (m)	TABLE ANGLE (Degree)	RAW VALUE (dBuV)	CORRECTION FACTOR (dB/m)
1	*5700.00	102.3 PK			1.37 H	289	62.5	39.8
2	*5700.00	92.5 AV			1.37 H	289	52.7	39.8
3	#5725.00	62.9 PK	68.2	-5.3	1.42 H	313	58.5	4.4
4	11400.00	62.6 PK	74.0	-11.4	1.09 H	313	45.3	17.3
5	11400.00	48.4 AV	54.0	-5.6	1.09 H	313	31.1	17.3

Remarks:

1. Emission Level(dBuV/m) = Raw Value(dBuV) + Correction Factor(dB/m)
2. Correction Factor(dB/m) = Antenna Factor(dB/m) + Cable Factor(dB) – Pre-Amplifier Factor(dB)
3. The other emission levels were very low against the limit
4. Margin value = Emission Level – Limit value
5. " * ": Fundamental frequency

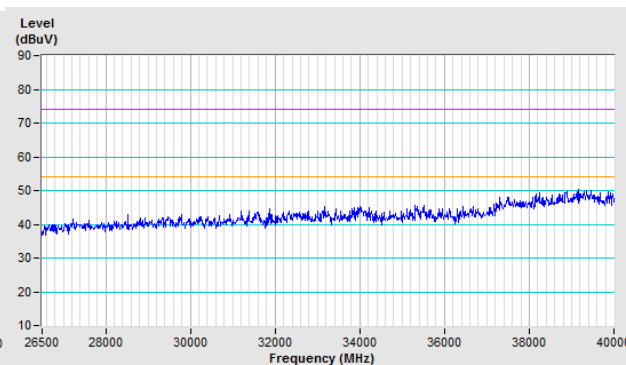
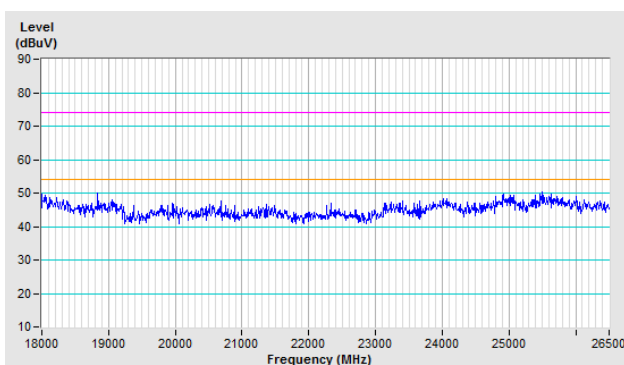
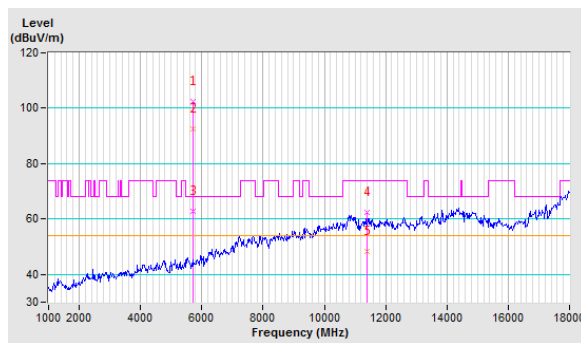

For Bandedge

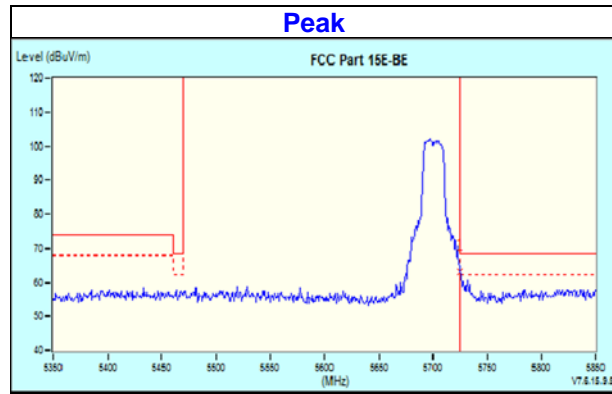

CHANNEL	TX Channel 140	DETECTOR FUNCTION	Peak (PK) Average (AV)
FREQUENCY RANGE	1GHz ~ 40GHz		

ANTENNA POLARITY & TEST DISTANCE: VERTICAL AT 3 M								
NO.	FREQ. (MHz)	EMISSION LEVEL (dBuV/m)	LIMIT (dBuV/m)	MARGIN (dB)	ANTENNA HEIGHT (m)	TABLE ANGLE (Degree)	RAW VALUE (dBuV)	CORRECTION FACTOR (dB/m)
1	*5700.00	101.9 PK			1.05 V	60	62.1	39.8
2	*5700.00	92.0 AV			1.05 V	60	52.2	39.8
3	#5725.00	60.9 PK	68.2	-7.3	1.13 V	82	56.5	4.4
4	11400.00	64.2 PK	74.0	-9.8	1.05 V	318	46.9	17.3
5	11400.00	49.6 AV	54.0	-4.4	1.05 V	318	32.3	17.3

Remarks:

1. Emission Level(dBuV/m) = Raw Value(dBuV) + Correction Factor(dB/m)
2. Correction Factor(dB/m) = Antenna Factor(dB/m) + Cable Factor(dB) – Pre-Amplifier Factor(dB)
3. The other emission levels were very low against the limit
4. Margin value = Emission Level – Limit value
5. " * ": Fundamental frequency

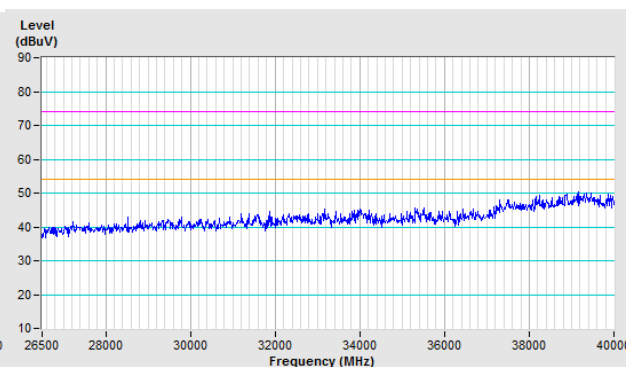
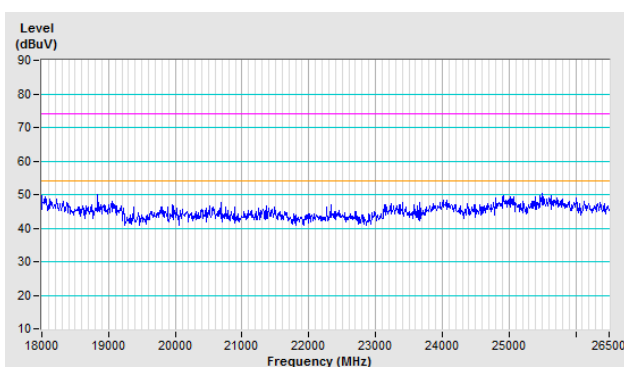
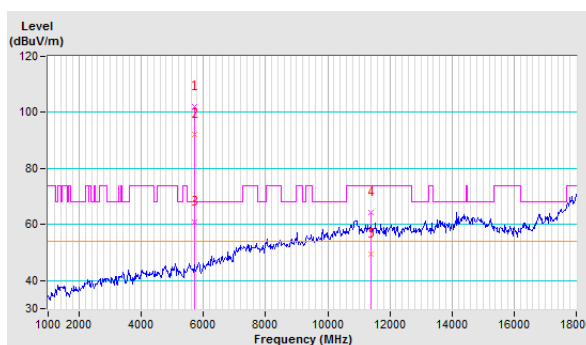

For Bandedge

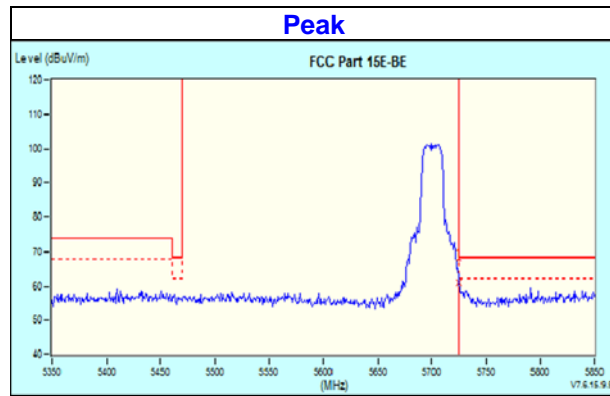

CHANNEL	TX Channel 149	DETECTOR FUNCTION	Peak (PK)
FREQUENCY RANGE	1GHz ~ 40GHz		Average (AV)

ANTENNA POLARITY & TEST DISTANCE: HORIZONTAL AT 3 M								
NO.	FREQ. (MHz)	EMISSION LEVEL (dBuV/m)	LIMIT (dBuV/m)	MARGIN (dB)	ANTENNA HEIGHT (m)	TABLE ANGLE (Degree)	RAW VALUE (dBuV)	CORRECTION FACTOR (dB/m)
1	#5606.41	54.4 PK	68.2	-13.8	1.23 H	287	50.1	4.3
2	*5745.00	103.5 PK			1.23 H	287	63.4	40.1
3	*5745.00	93.3 AV			1.23 H	287	53.2	40.1
4	#5973.72	57.4 PK	68.2	-10.8	1.23 H	287	52.3	5.1
5	11490.00	63.2 PK	74.0	-10.8	1.09 H	305	45.6	17.6
6	11490.00	48.8 AV	54.0	-5.2	1.09 H	305	31.2	17.6

Remarks:

1. Emission Level(dBuV/m) = Raw Value(dBuV) + Correction Factor(dB/m)
2. Correction Factor(dB/m) = Antenna Factor(dB/m) + Cable Factor(dB) – Pre-Amplifier Factor(dB)
3. The other emission levels were very low against the limit
4. Margin value = Emission Level – Limit value
5. " * ": Fundamental frequency

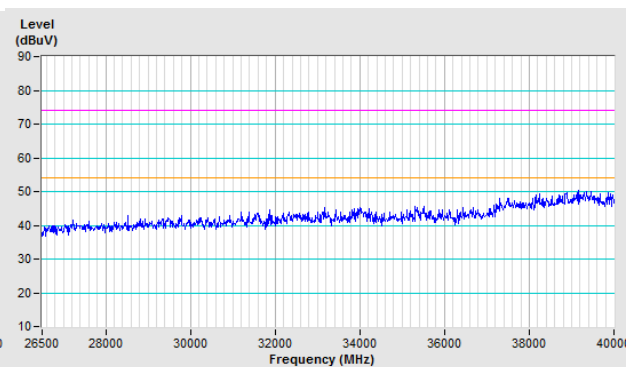
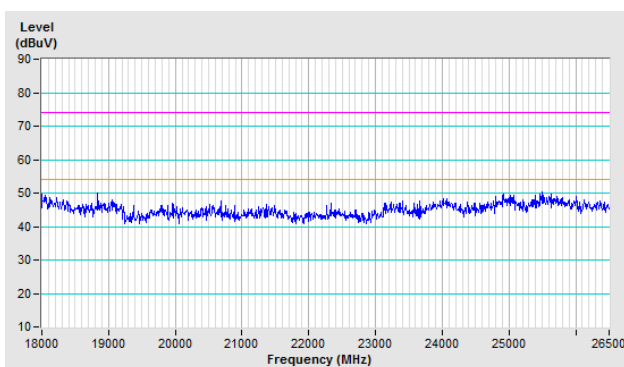
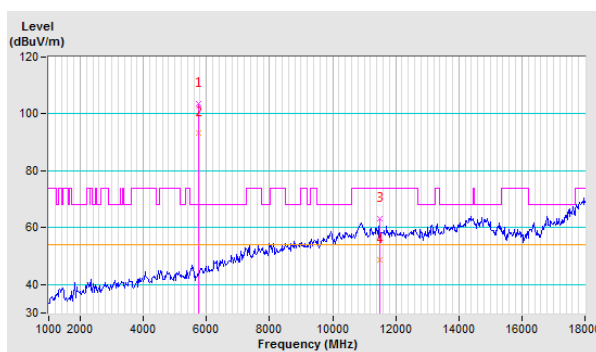

For Bandedge

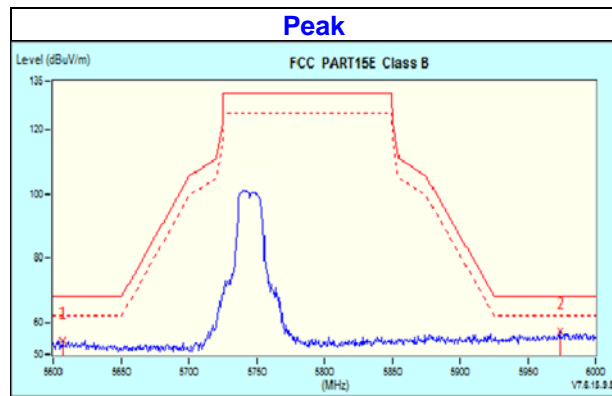

CHANNEL	TX Channel 149	DETECTOR FUNCTION	Peak (PK) Average (AV)
FREQUENCY RANGE	1GHz ~ 40GHz		

ANTENNA POLARITY & TEST DISTANCE: VERTICAL AT 3 M								
NO.	FREQ. (MHz)	EMISSION LEVEL (dBuV/m)	LIMIT (dBuV/m)	MARGIN (dB)	ANTENNA HEIGHT (m)	TABLE ANGLE (Degree)	RAW VALUE (dBuV)	CORRECTION FACTOR (dB/m)
1	#5601.28	55.1 PK	68.2	-13.1	2.60 V	322	50.8	4.3
2	*5745.00	103.8 PK			2.60 V	322	63.7	40.1
3	*5745.00	93.6 AV			2.60 V	322	53.5	40.1
4	#5976.28	57.4 PK	68.2	-10.8	2.60 V	322	52.3	5.1
5	11490.00	64.3 PK	74.0	-9.7	1.14 V	320	46.7	17.6
6	11490.00	50.5 AV	54.0	-3.5	1.14 V	320	32.9	17.6

Remarks:

1. Emission Level(dBuV/m) = Raw Value(dBuV) + Correction Factor(dB/m)
2. Correction Factor(dB/m) = Antenna Factor(dB/m) + Cable Factor(dB) – Pre-Amplifier Factor(dB)
3. The other emission levels were very low against the limit
4. Margin value = Emission Level – Limit value
5. " * ": Fundamental frequency

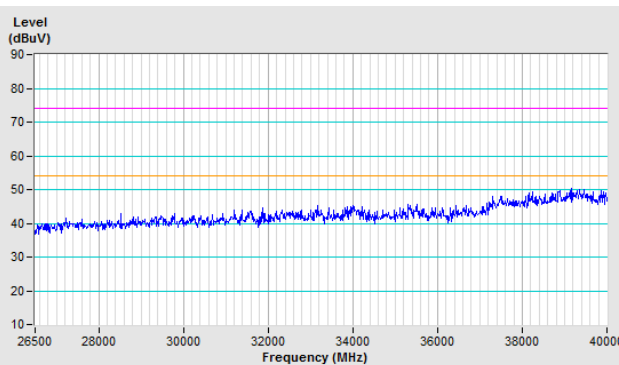
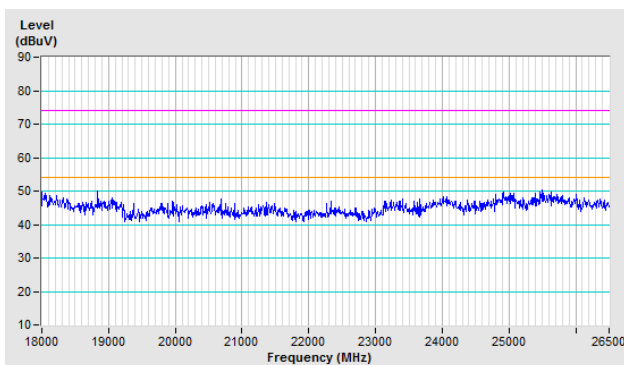
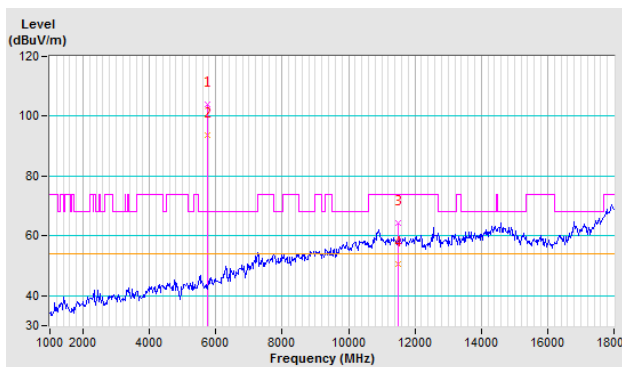

For Bandedge

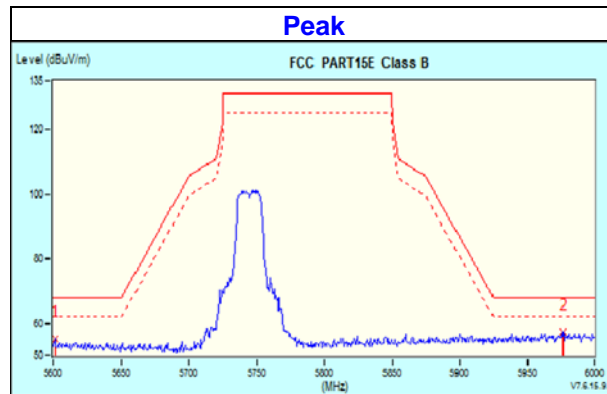

CHANNEL	TX Channel 157	DETECTOR FUNCTION	Peak (PK)
FREQUENCY RANGE	1GHz ~ 40GHz		Average (AV)

ANTENNA POLARITY & TEST DISTANCE: HORIZONTAL AT 3 M								
NO.	FREQ. (MHz)	EMISSION LEVEL (dBuV/m)	LIMIT (dBuV/m)	MARGIN (dB)	ANTENNA HEIGHT (m)	TABLE ANGLE (Degree)	RAW VALUE (dBuV)	CORRECTION FACTOR (dB/m)
1	#5633.33	53.8 PK	68.2	-14.4	1.10 H	287	49.6	4.2
2	*5785.00	103.1 PK			1.10 H	287	62.8	40.3
3	*5785.00	92.9 AV			1.10 H	287	52.6	40.3
4	#5984.62	56.8 PK	68.2	-11.4	1.10 H	287	51.7	5.1
5	11570.00	63.5 PK	74.0	-10.5	1.09 H	300	46.0	17.5
6	11570.00	49.1 AV	54.0	-4.9	1.09 H	300	31.6	17.5

Remarks:

1. Emission Level(dBuV/m) = Raw Value(dBuV) + Correction Factor(dB/m)
2. Correction Factor(dB/m) = Antenna Factor(dB/m) + Cable Factor(dB) – Pre-Amplifier Factor(dB)
3. The other emission levels were very low against the limit
4. Margin value = Emission Level – Limit value
5. " * ": Fundamental frequency

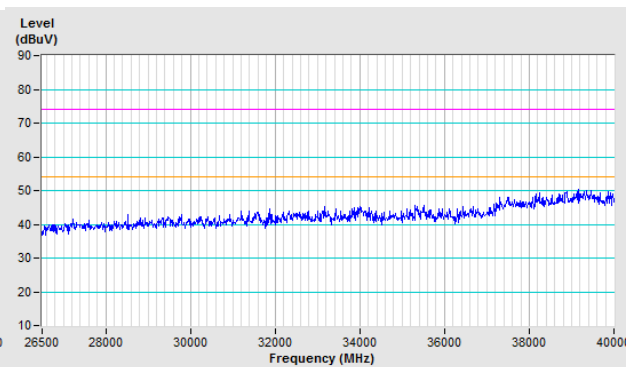
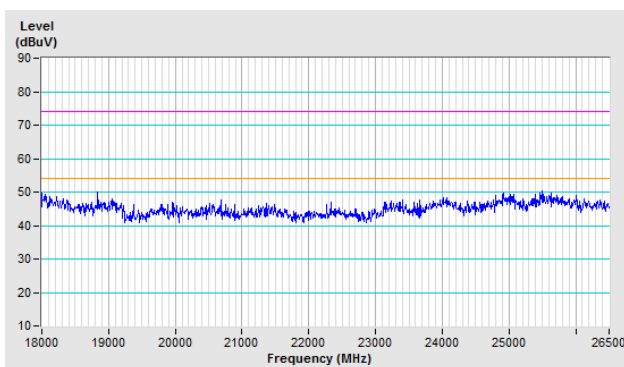
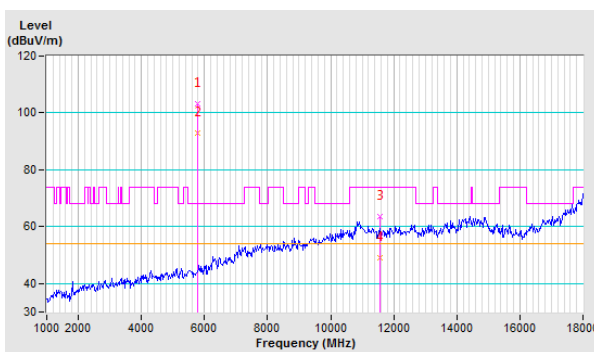

For Bandedge

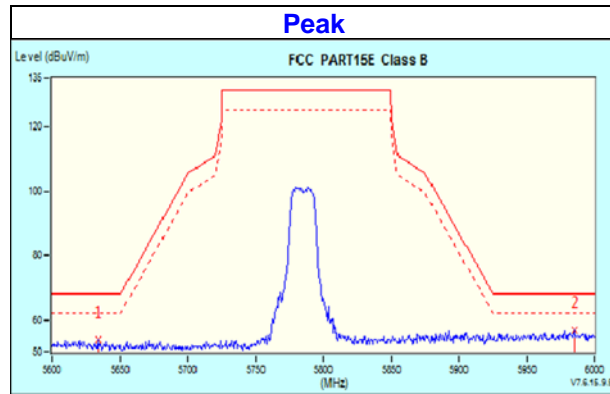

CHANNEL	TX Channel 157	DETECTOR FUNCTION	Peak (PK) Average (AV)
FREQUENCY RANGE	1GHz ~ 40GHz		

ANTENNA POLARITY & TEST DISTANCE: VERTICAL AT 3 M								
NO.	FREQ. (MHz)	EMISSION LEVEL (dBuV/m)	LIMIT (dBuV/m)	MARGIN (dB)	ANTENNA HEIGHT (m)	TABLE ANGLE (Degree)	RAW VALUE (dBuV)	CORRECTION FACTOR (dB/m)
1	#5620.51	54.6 PK	68.2	-13.6	2.77 V	320	50.3	4.3
2	*5785.00	103.7 PK			2.77 V	320	63.4	40.3
3	*5785.00	93.7 AV			2.77 V	320	53.4	40.3
4	#5965.38	56.8 PK	68.2	-11.4	2.77 V	320	51.9	4.9
5	11570.00	65.8 PK	74.0	-8.2	1.13 V	315	48.3	17.5
6	11570.00	50.2 AV	54.0	-3.8	1.13 V	315	32.7	17.5

Remarks:

1. Emission Level(dBuV/m) = Raw Value(dBuV) + Correction Factor(dB/m)
2. Correction Factor(dB/m) = Antenna Factor(dB/m) + Cable Factor(dB) – Pre-Amplifier Factor(dB)
3. The other emission levels were very low against the limit
4. Margin value = Emission Level – Limit value
5. " * ": Fundamental frequency

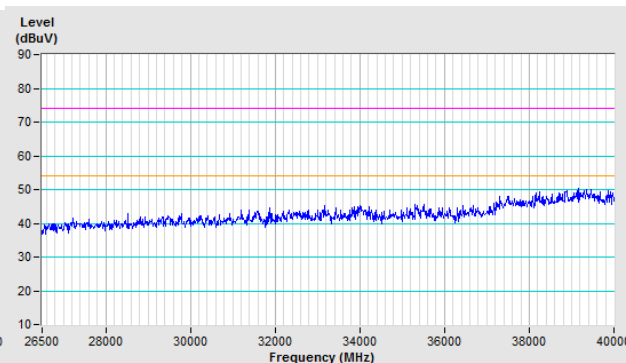
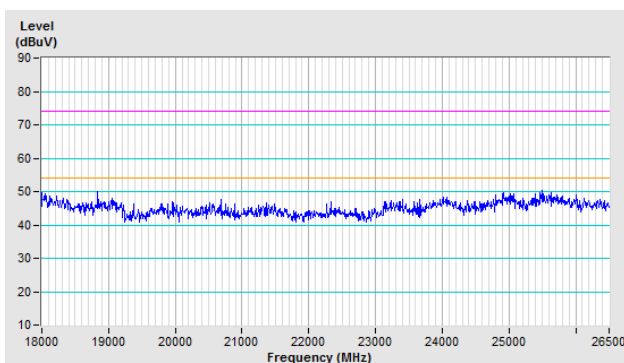
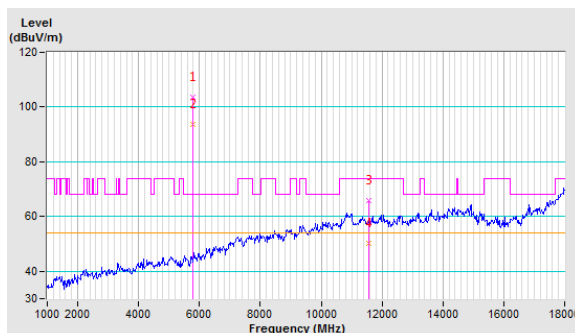

For Bandedge

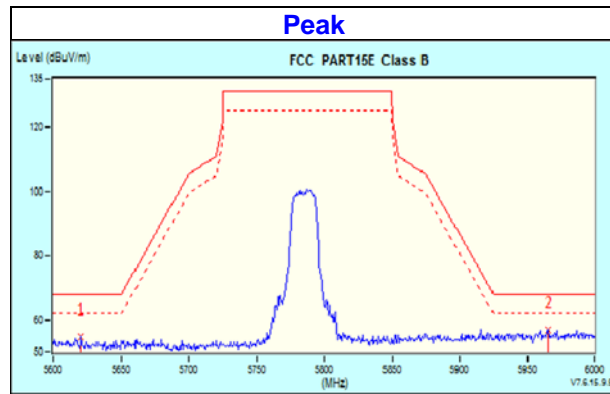

CHANNEL	TX Channel 165	DETECTOR FUNCTION	Peak (PK)
FREQUENCY RANGE	1GHz ~ 40GHz		Average (AV)

ANTENNA POLARITY & TEST DISTANCE: HORIZONTAL AT 3 M								
NO.	FREQ. (MHz)	EMISSION LEVEL (dBuV/m)	LIMIT (dBuV/m)	MARGIN (dB)	ANTENNA HEIGHT (m)	TABLE ANGLE (Degree)	RAW VALUE (dBuV)	CORRECTION FACTOR (dB/m)
1	#5608.97	54.3 PK	68.2	-13.9	1.10 H	286	50.0	4.3
2	*5825.00	102.8 PK			1.10 H	286	62.4	40.4
3	*5825.00	92.5 AV			1.10 H	286	52.1	40.4
4	#5959.62	56.3 PK	68.2	-11.9	1.10 H	286	51.4	4.9
5	11650.00	63.7 PK	74.0	-10.3	1.08 H	299	46.6	17.1
6	11650.00	49.3 AV	54.0	-4.7	1.08 H	299	32.2	17.1

Remarks:

1. Emission Level(dBuV/m) = Raw Value(dBuV) + Correction Factor(dB/m)
2. Correction Factor(dB/m) = Antenna Factor(dB/m) + Cable Factor(dB) – Pre-Amplifier Factor(dB)
3. The other emission levels were very low against the limit
4. Margin value = Emission Level – Limit value
5. " * ": Fundamental frequency

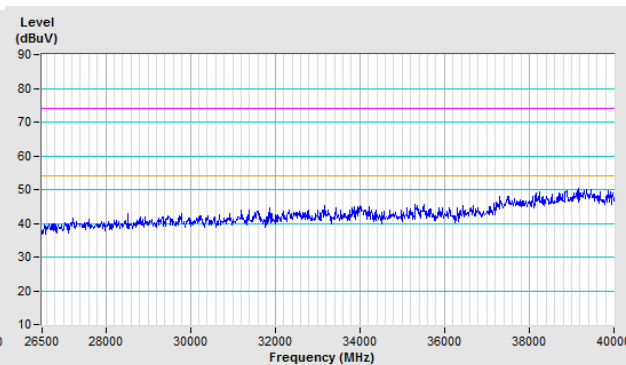
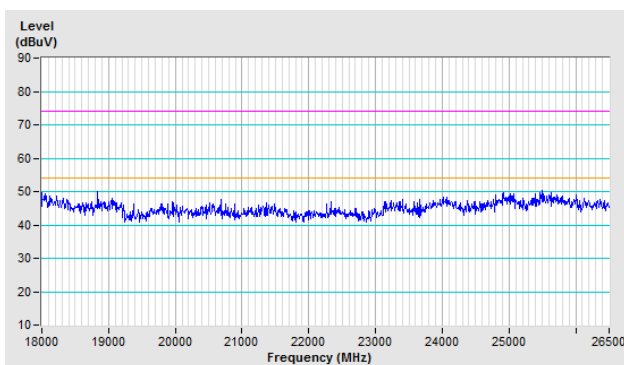
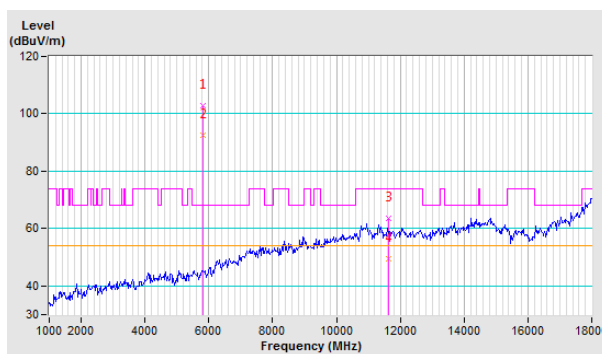

For Bandedge

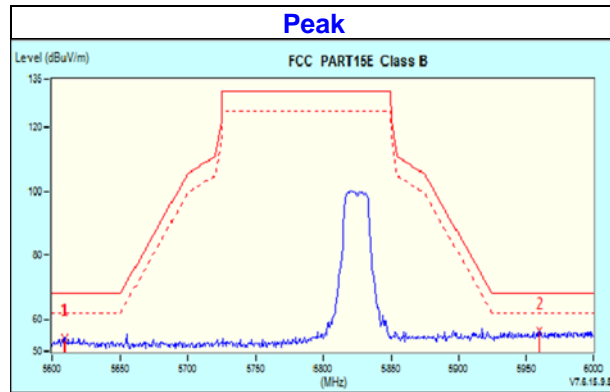

CHANNEL	TX Channel 165	DETECTOR FUNCTION	Peak (PK)
FREQUENCY RANGE	1GHz ~ 40GHz		Average (AV)

ANTENNA POLARITY & TEST DISTANCE: VERTICAL AT 3 M								
NO.	FREQ. (MHz)	EMISSION LEVEL (dBuV/m)	LIMIT (dBuV/m)	MARGIN (dB)	ANTENNA HEIGHT (m)	TABLE ANGLE (Degree)	RAW VALUE (dBuV)	CORRECTION FACTOR (dB/m)
1	#5605.13	54.4 PK	68.2	-13.8	1.98 V	348	50.1	4.3
2	*5825.00	100.6 PK			1.98 V	348	60.2	40.4
3	*5825.00	90.6 AV			1.98 V	348	50.2	40.4
4	#5965.38	56.4 PK	68.2	-11.8	1.98 V	348	51.5	4.9
5	11650.00	64.3 PK	74.0	-9.7	1.31 V	317	47.2	17.1
6	11650.00	49.7 AV	54.0	-4.3	1.31 V	317	32.6	17.1

Remarks:

1. Emission Level(dBuV/m) = Raw Value(dBuV) + Correction Factor(dB/m)
2. Correction Factor(dB/m) = Antenna Factor(dB/m) + Cable Factor(dB) – Pre-Amplifier Factor(dB)
3. The other emission levels were very low against the limit
4. Margin value = Emission Level – Limit value
5. " * ": Fundamental frequency

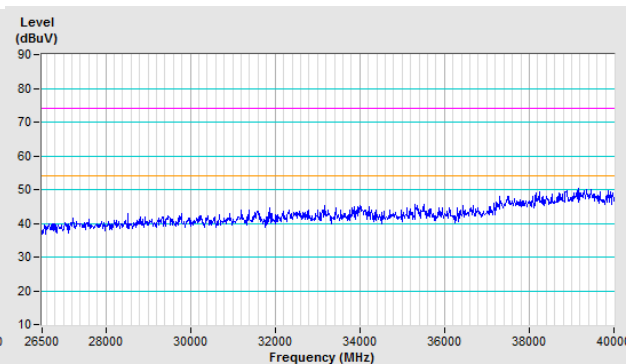
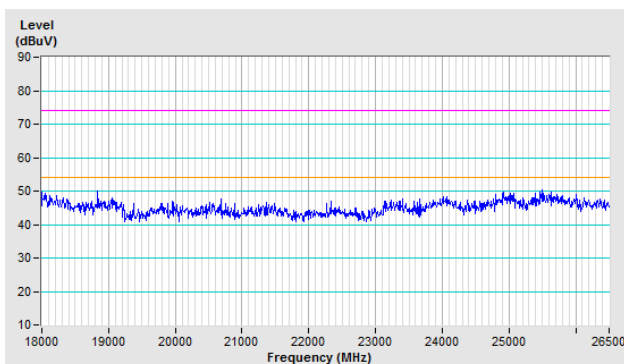
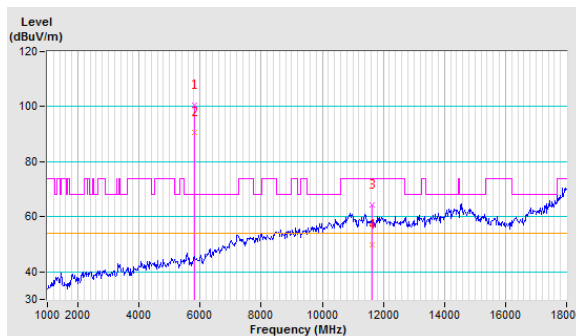

For Bandedge

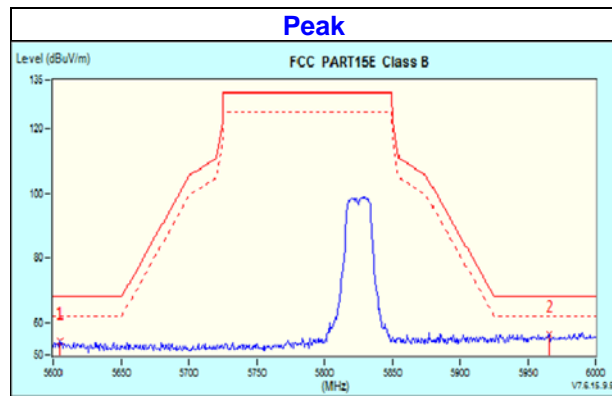

802.11n (HT40)

CHANNEL	TX Channel 38	DETECTOR FUNCTION	Peak (PK) Average (AV)
FREQUENCY RANGE	1GHz ~ 40GHz		

ANTENNA POLARITY & TEST DISTANCE: HORIZONTAL AT 3 M								
NO.	FREQ. (MHz)	EMISSION LEVEL (dBuV/m)	LIMIT (dBuV/m)	MARGIN (dB)	ANTENNA HEIGHT (m)	TABLE ANGLE (Degree)	RAW VALUE (dBuV)	CORRECTION FACTOR (dB/m)
1	5150.00	55.7 PK	74.0	-18.3	3.63 H	255	51.8	3.9
2	5150.00	41.5 AV	54.0	-12.5	3.63 H	255	37.6	3.9
3	*5190.00	92.2 PK			3.80 H	253	52.7	39.5
4	*5190.00	82.7 AV			3.80 H	253	43.2	39.5
5	#10380.00	59.2 PK	68.2	-9.0	1.15 H	33	43.3	15.9

Remarks:

1. Emission Level(dBuV/m) = Raw Value(dBuV) + Correction Factor(dB/m)
2. Correction Factor(dB/m) = Antenna Factor(dB/m) + Cable Factor(dB) – Pre-Amplifier Factor(dB)
3. The other emission levels were very low against the limit
4. Margin value = Emission Level – Limit value
5. " * ": Fundamental frequency
6. " # ": The radiated frequency is out of the restricted band.

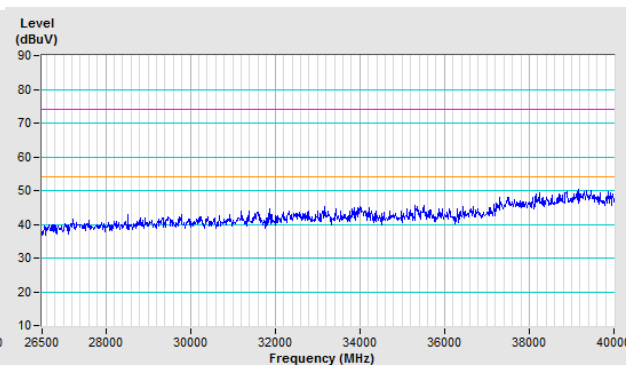
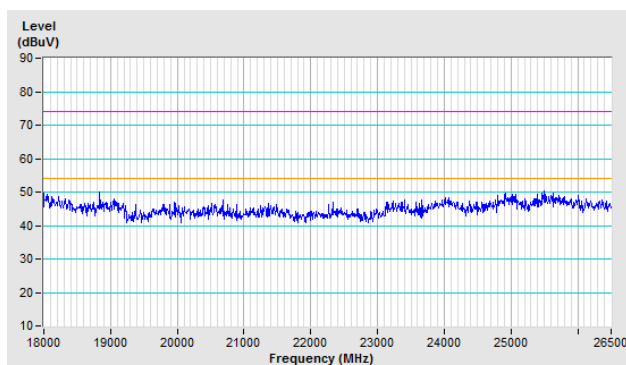
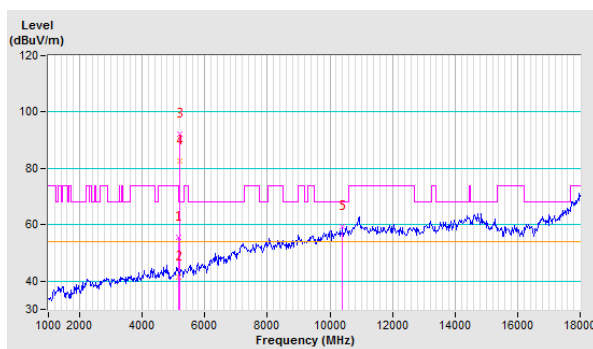

For Bandedge

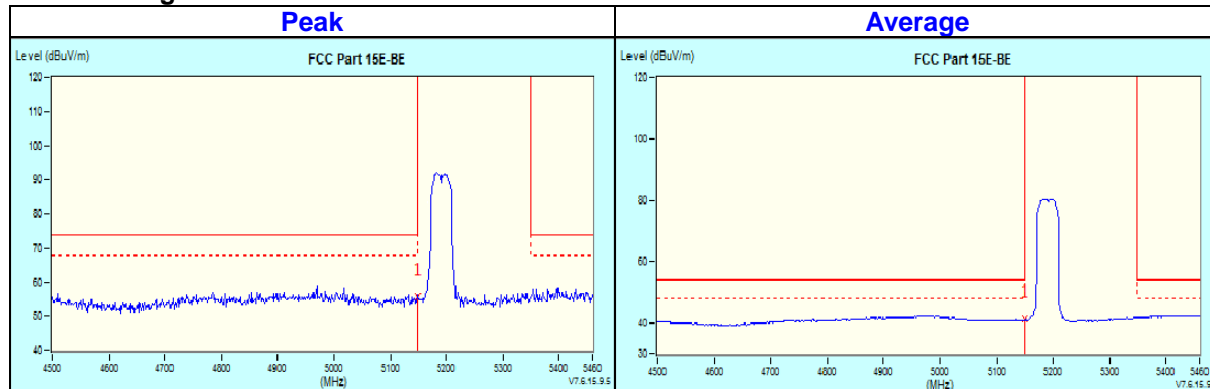

CHANNEL	TX Channel 38	DETECTOR FUNCTION	Peak (PK) Average (AV)
FREQUENCY RANGE	1GHz ~ 40GHz		

ANTENNA POLARITY & TEST DISTANCE: VERTICAL AT 3 M								
NO.	FREQ. (MHz)	EMISSION LEVEL (dBuV/m)	LIMIT (dBuV/m)	MARGIN (dB)	ANTENNA HEIGHT (m)	TABLE ANGLE (Degree)	RAW VALUE (dBuV)	CORRECTION FACTOR (dB/m)
1	5150.00	58.7 PK	74.0	-15.3	1.32 V	32	54.8	3.9
2	5150.00	44.2 AV	54.0	-9.8	1.32 V	32	40.3	3.9
3	*5190.00	99.4 PK			1.50 V	40	59.9	39.5
4	*5190.00	89.9 AV			1.50 V	40	50.4	39.5
5	#10380.00	61.9 PK	68.2	-6.3	1.41 V	318	46.0	15.9

Remarks:

1. Emission Level(dBuV/m) = Raw Value(dBuV) + Correction Factor(dB/m)
2. Correction Factor(dB/m) = Antenna Factor(dB/m) + Cable Factor(dB) – Pre-Amplifier Factor(dB)
3. The other emission levels were very low against the limit
4. Margin value = Emission Level – Limit value
5. " * ": Fundamental frequency
6. " # ": The radiated frequency is out of the restricted band.

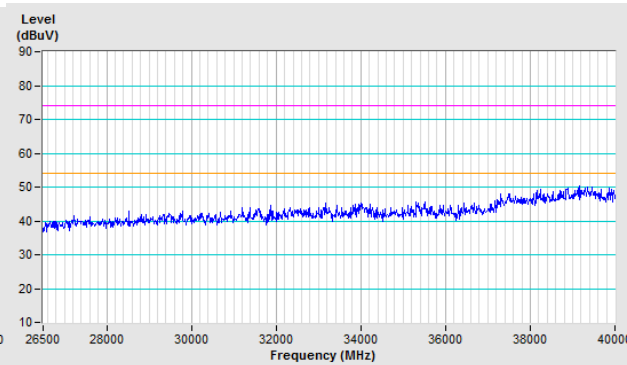
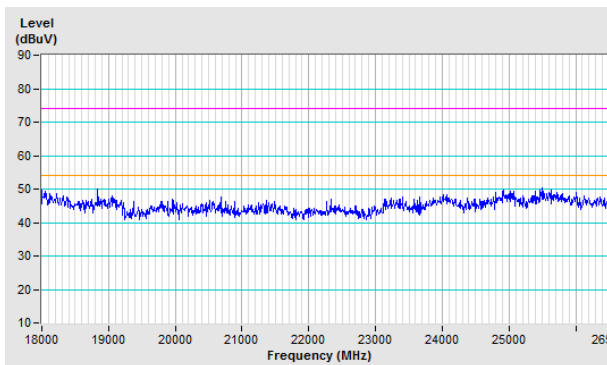
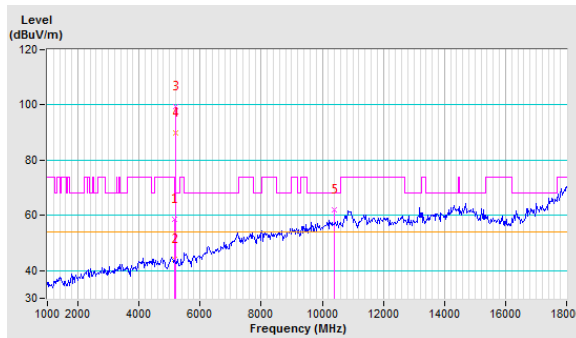

For Bandedge

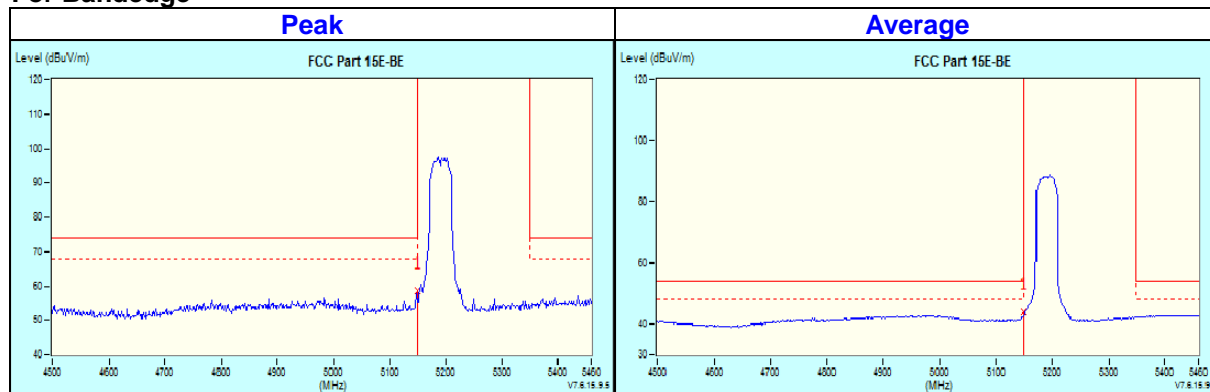

CHANNEL	TX Channel 46	DETECTOR FUNCTION	Peak (PK)
FREQUENCY RANGE	1GHz ~ 40GHz		Average (AV)

ANTENNA POLARITY & TEST DISTANCE: HORIZONTAL AT 3 M								
NO.	FREQ. (MHz)	EMISSION LEVEL (dBuV/m)	LIMIT (dBuV/m)	MARGIN (dB)	ANTENNA HEIGHT (m)	TABLE ANGLE (Degree)	RAW VALUE (dBuV)	CORRECTION FACTOR (dB/m)
1	5150.00	56.1 PK	74.0	-17.9	3.51 H	321	52.2	3.9
2	5150.00	42.8 AV	54.0	-11.2	3.51 H	321	38.9	3.9
3	*5230.00	92.3 PK			3.79 H	347	53.0	39.3
4	*5230.00	82.0 AV			3.79 H	347	42.7	39.3
5	#10460.00	59.3 PK	68.2	-8.9	1.23 H	40	42.7	16.6

Remarks:

1. Emission Level(dBuV/m) = Raw Value(dBuV) + Correction Factor(dB/m)
2. Correction Factor(dB/m) = Antenna Factor(dB/m) + Cable Factor(dB) – Pre-Amplifier Factor(dB)
3. The other emission levels were very low against the limit
4. Margin value = Emission Level – Limit value
5. " * ": Fundamental frequency
6. " # ": The radiated frequency is out of the restricted band.

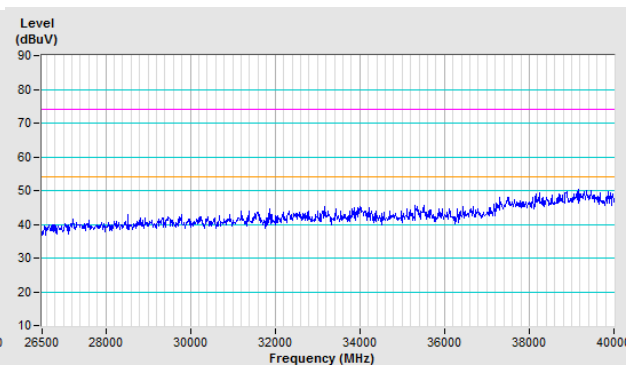
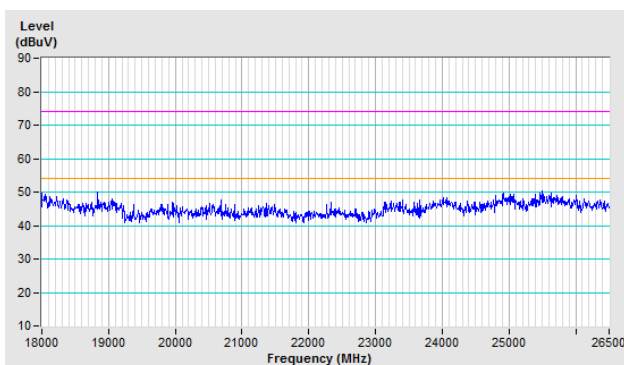
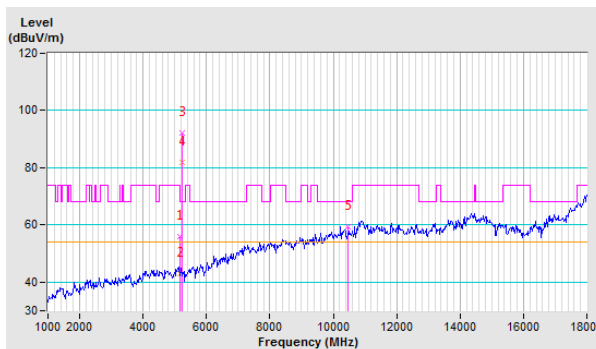

For Bandedge

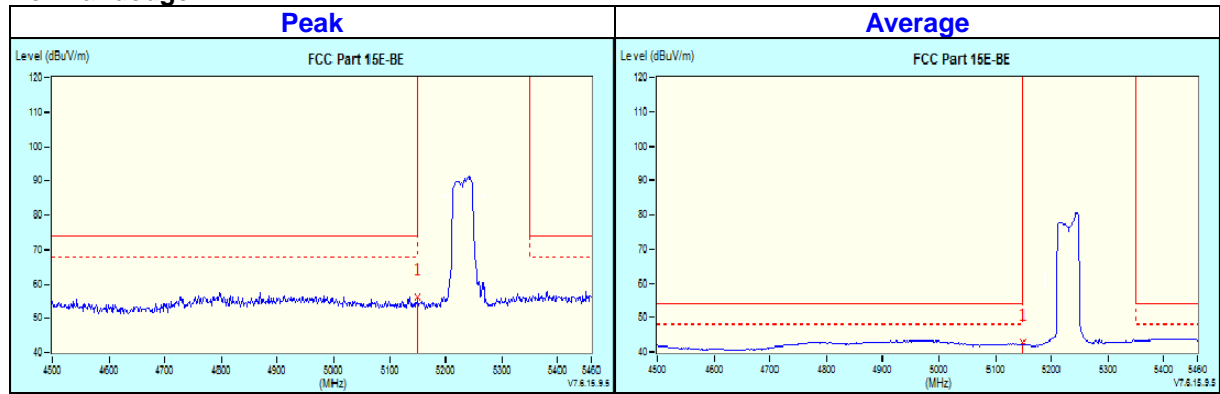

CHANNEL	TX Channel 46	DETECTOR FUNCTION	Peak (PK) Average (AV)
FREQUENCY RANGE	1GHz ~ 40GHz		

ANTENNA POLARITY & TEST DISTANCE: VERTICAL AT 3 M								
NO.	FREQ. (MHz)	EMISSION LEVEL (dBuV/m)	LIMIT (dBuV/m)	MARGIN (dB)	ANTENNA HEIGHT (m)	TABLE ANGLE (Degree)	RAW VALUE (dBuV)	CORRECTION FACTOR (dB/m)
1	5150.00	56.2 PK	74.0	-17.8	1.44 V	39	52.3	3.9
2	5150.00	41.7 AV	54.0	-12.3	1.44 V	39	37.8	3.9
3	*5230.00	99.0 PK			1.21 V	48	59.7	39.3
4	*5230.00	88.8 AV			1.21 V	48	49.5	39.3
5	#10460.00	60.9 PK	68.2	-7.3	1.57 V	316	44.3	16.6

Remarks:

1. Emission Level(dBuV/m) = Raw Value(dBuV) + Correction Factor(dB/m)
2. Correction Factor(dB/m) = Antenna Factor(dB/m) + Cable Factor(dB) – Pre-Amplifier Factor(dB)
3. The other emission levels were very low against the limit
4. Margin value = Emission Level – Limit value
5. " * ": Fundamental frequency
6. " # ": The radiated frequency is out of the restricted band.

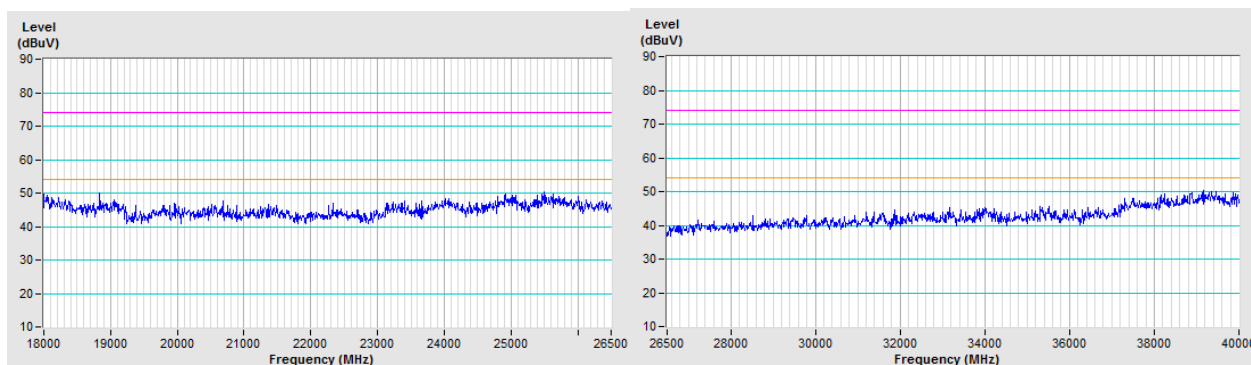
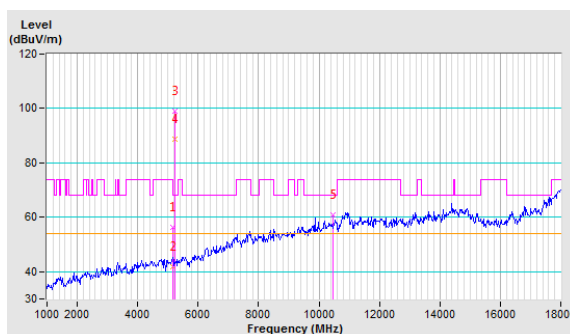

For Bandedge

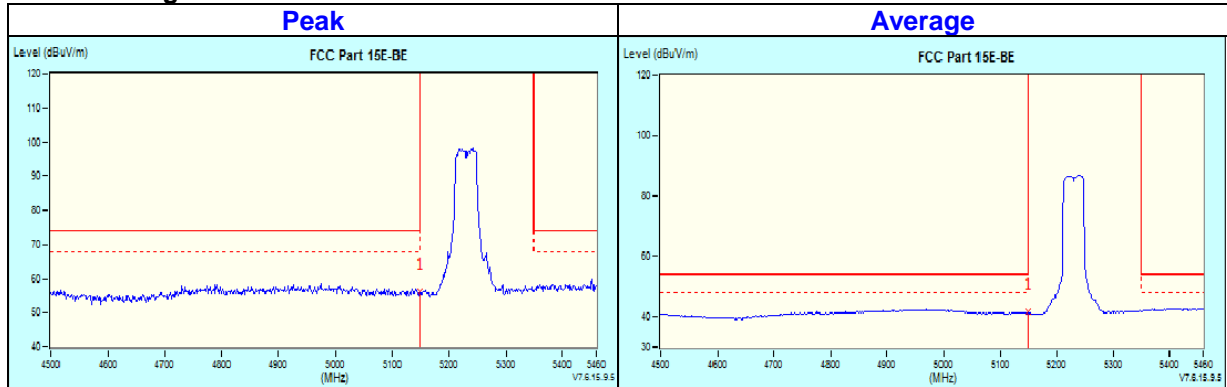

CHANNEL	TX Channel 54	DETECTOR FUNCTION	Peak (PK)
FREQUENCY RANGE	1GHz ~ 40GHz		Average (AV)

ANTENNA POLARITY & TEST DISTANCE: HORIZONTAL AT 3 M								
NO.	FREQ. (MHz)	EMISSION LEVEL (dBuV/m)	LIMIT (dBuV/m)	MARGIN (dB)	ANTENNA HEIGHT (m)	TABLE ANGLE (Degree)	RAW VALUE (dBuV)	CORRECTION FACTOR (dB/m)
1	5150.00	55.4 PK	74.0	-18.6	3.73 H	353	51.5	3.9
2	5150.00	41.8 AV	54.0	-12.2	3.73 H	353	37.9	3.9
3	*5270.00	92.4 PK			3.90 H	324	53.1	39.3
4	*5270.00	82.3 AV			3.90 H	324	43.0	39.3
5	#10540.00	63.0 PK	68.2	-5.2	1.13 H	66	46.0	17.0

Remarks:

1. Emission Level(dBuV/m) = Raw Value(dBuV) + Correction Factor(dB/m)
2. Correction Factor(dB/m) = Antenna Factor(dB/m) + Cable Factor(dB) – Pre-Amplifier Factor(dB)
3. The other emission levels were very low against the limit
4. Margin value = Emission Level – Limit value
5. " * ": Fundamental frequency
6. " # ": The radiated frequency is out of the restricted band.

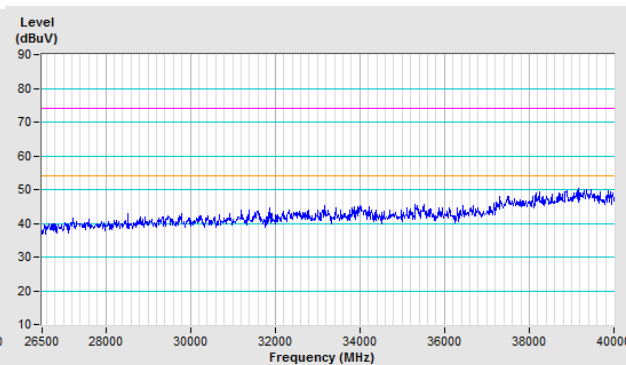
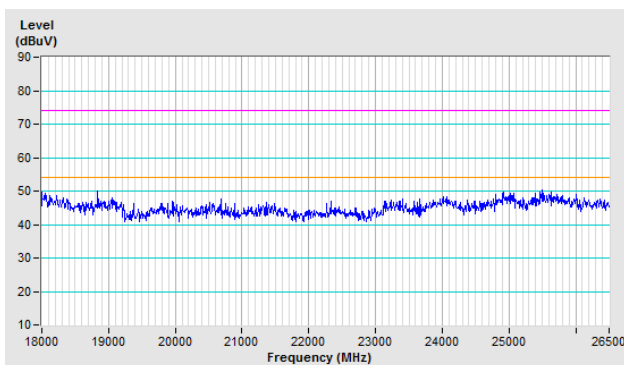
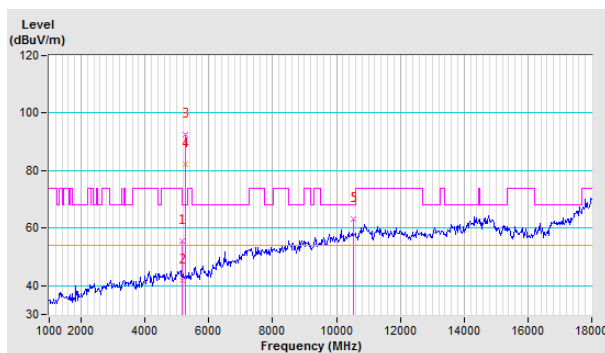

For Bandedge

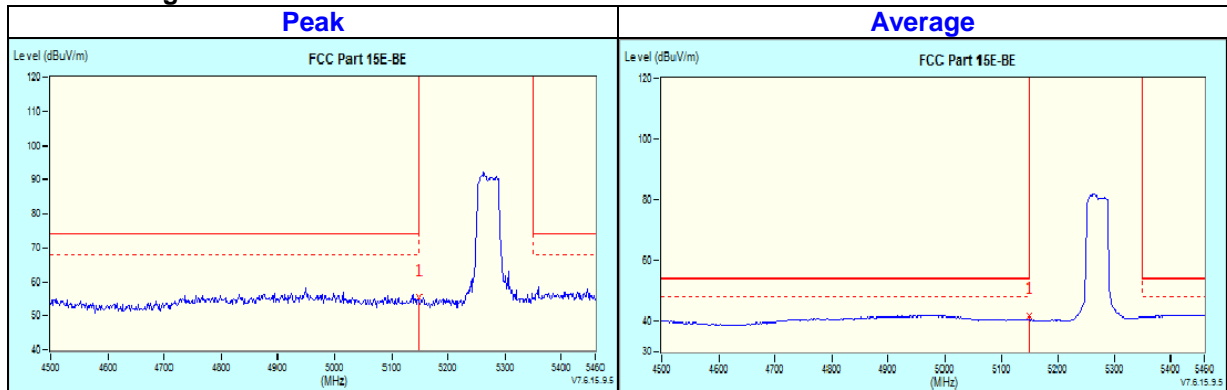

CHANNEL	TX Channel 54	DETECTOR FUNCTION	Peak (PK) Average (AV)
FREQUENCY RANGE	1GHz ~ 40GHz		

ANTENNA POLARITY & TEST DISTANCE: VERTICAL AT 3 M								
NO.	FREQ. (MHz)	EMISSION LEVEL (dBuV/m)	LIMIT (dBuV/m)	MARGIN (dB)	ANTENNA HEIGHT (m)	TABLE ANGLE (Degree)	RAW VALUE (dBuV)	CORRECTION FACTOR (dB/m)
1	5150.00	55.2 PK	74.0	-18.8	1.29 V	33	51.3	3.9
2	5150.00	41.9 AV	54.0	-12.1	1.29 V	33	38.0	3.9
3	*5270.00	99.6 PK			1.37 V	40	60.3	39.3
4	*5270.00	89.5 AV			1.37 V	40	50.2	39.3
5	#10540.00	62.5 PK	68.2	-5.7	1.65 V	318	45.5	17.0

Remarks:

1. Emission Level(dBuV/m) = Raw Value(dBuV) + Correction Factor(dB/m)
2. Correction Factor(dB/m) = Antenna Factor(dB/m) + Cable Factor(dB) – Pre-Amplifier Factor(dB)
3. The other emission levels were very low against the limit
4. Margin value = Emission Level – Limit value
5. " * ": Fundamental frequency
6. " # ": The radiated frequency is out of the restricted band.

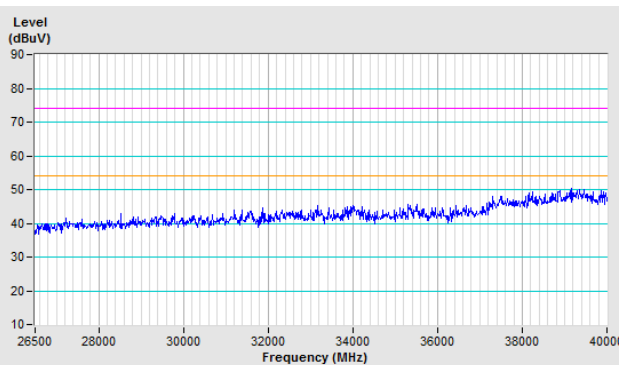
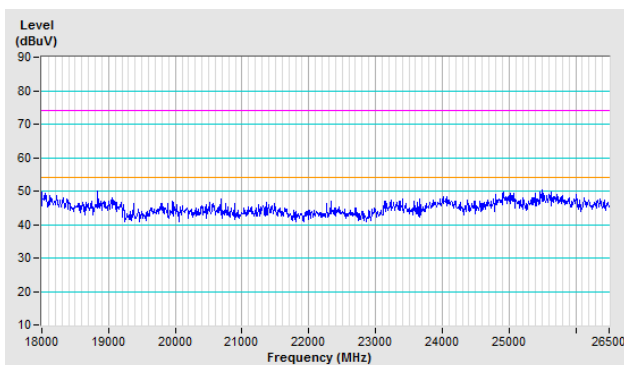
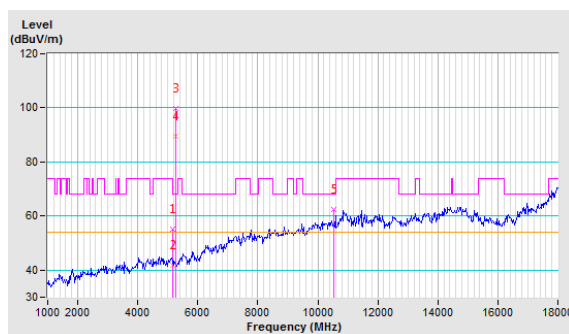

For Bandedge

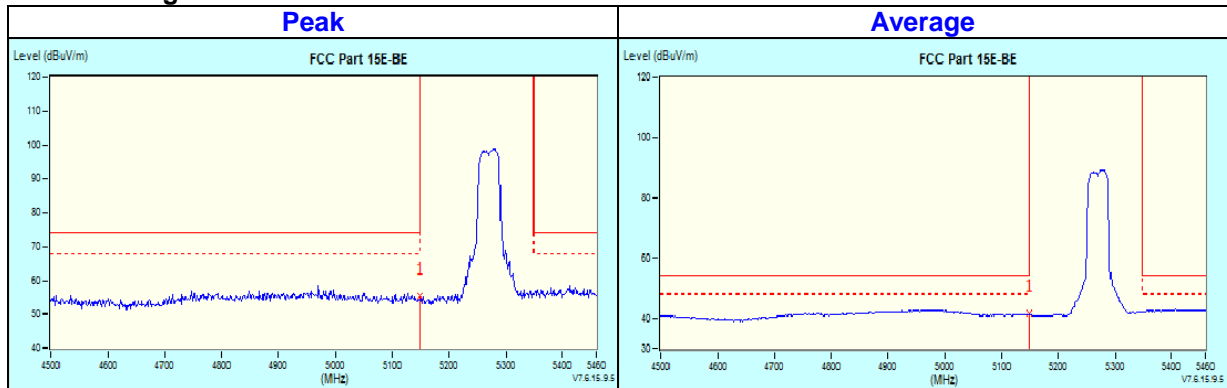

CHANNEL	TX Channel 62	DETECTOR FUNCTION	Peak (PK)
FREQUENCY RANGE	1GHz ~ 40GHz		Average (AV)

ANTENNA POLARITY & TEST DISTANCE: HORIZONTAL AT 3 M								
NO.	FREQ. (MHz)	EMISSION LEVEL (dBuV/m)	LIMIT (dBuV/m)	MARGIN (dB)	ANTENNA HEIGHT (m)	TABLE ANGLE (Degree)	RAW VALUE (dBuV)	CORRECTION FACTOR (dB/m)
1	*5310.00	94.4 PK			3.14 H	347	55.1	39.3
2	*5310.00	84.3 AV			3.14 H	347	45.0	39.3
3	5350.00	63.3 PK	74.0	-10.7	3.99 H	337	59.4	3.9
4	5350.00	45.8 AV	54.0	-8.2	3.99 H	337	41.9	3.9
5	10620.00	63.0 PK	74.0	-11.0	1.05 H	44	46.0	17.0
6	10620.00	50.8 AV	54.0	-3.2	1.05 H	44	33.8	17.0

Remarks:

1. Emission Level(dBuV/m) = Raw Value(dBuV) + Correction Factor(dB/m)
2. Correction Factor(dB/m) = Antenna Factor(dB/m) + Cable Factor(dB) – Pre-Amplifier Factor(dB)
3. The other emission levels were very low against the limit
4. Margin value = Emission Level – Limit value
5. " * ": Fundamental frequency

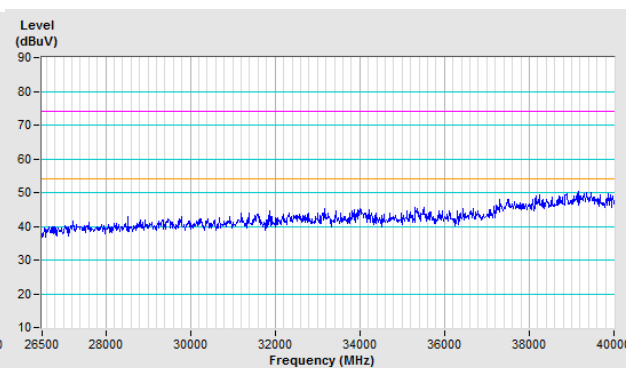
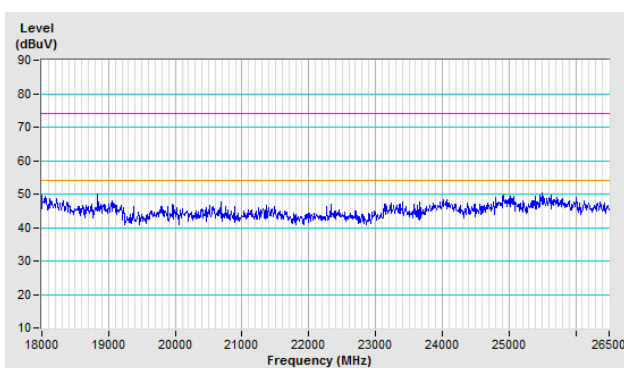
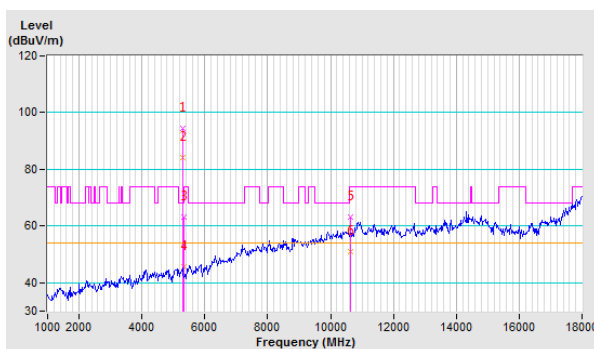

For Bandedge

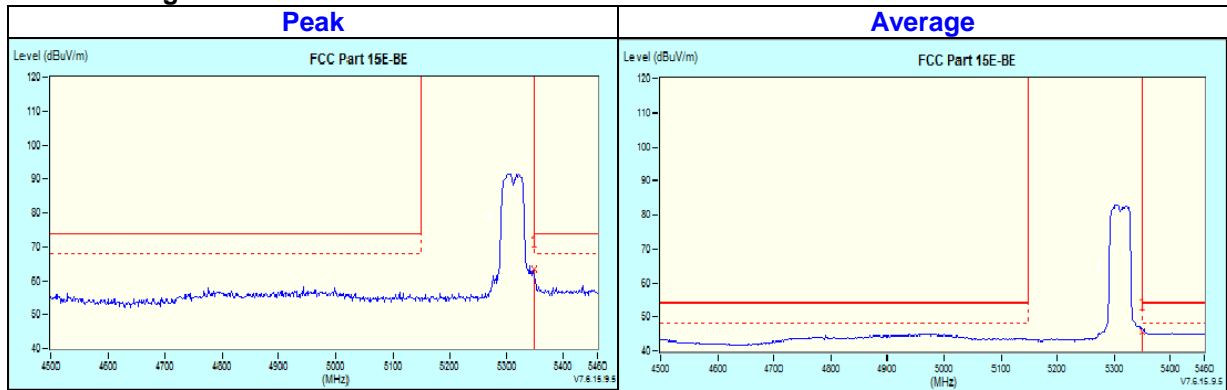

CHANNEL	TX Channel 62	DETECTOR FUNCTION	Peak (PK) Average (AV)
FREQUENCY RANGE	1GHz ~ 40GHz		

ANTENNA POLARITY & TEST DISTANCE: VERTICAL AT 3 M								
NO.	FREQ. (MHz)	EMISSION LEVEL (dBuV/m)	LIMIT (dBuV/m)	MARGIN (dB)	ANTENNA HEIGHT (m)	TABLE ANGLE (Degree)	RAW VALUE (dBuV)	CORRECTION FACTOR (dB/m)
1	*5310.00	99.4 PK			1.26 V	40	60.1	39.3
2	*5310.00	89.3 AV			1.26 V	40	50.0	39.3
3	5350.00	68.2 PK	74.0	-5.8	1.32 V	40	64.3	3.9
4	5350.00	48.9 AV	54.0	-5.1	1.32 V	40	45.0	3.9
5	10620.00	61.0 PK	74.0	-13.0	1.51 V	326	44.0	17.0
6	10620.00	48.5 AV	54.0	-5.5	1.51 V	326	31.5	17.0

Remarks:

1. Emission Level(dBuV/m) = Raw Value(dBuV) + Correction Factor(dB/m)
2. Correction Factor(dB/m) = Antenna Factor(dB/m) + Cable Factor(dB) – Pre-Amplifier Factor(dB)
3. The other emission levels were very low against the limit
4. Margin value = Emission Level – Limit value
5. " * ": Fundamental frequency

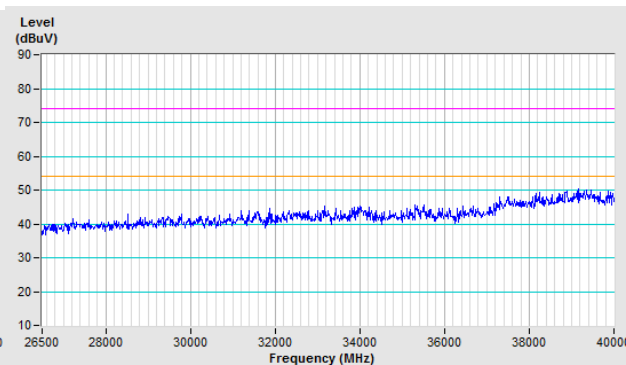
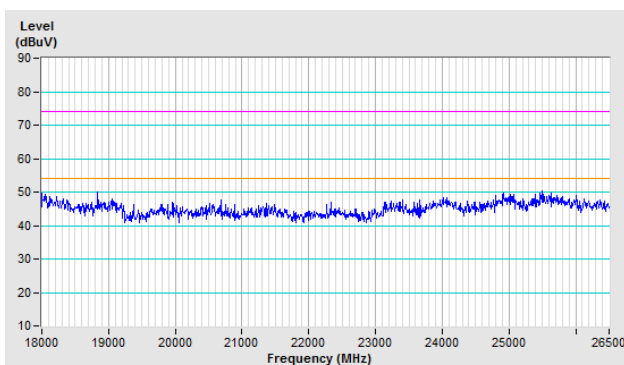
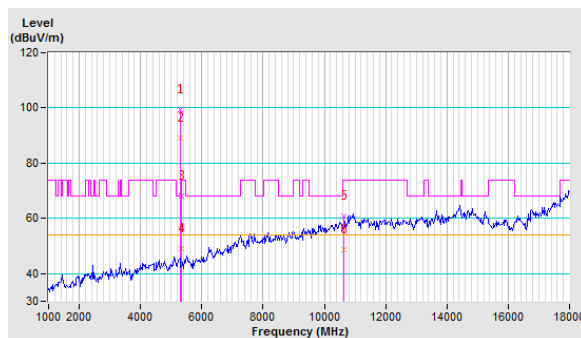

For Bandedge

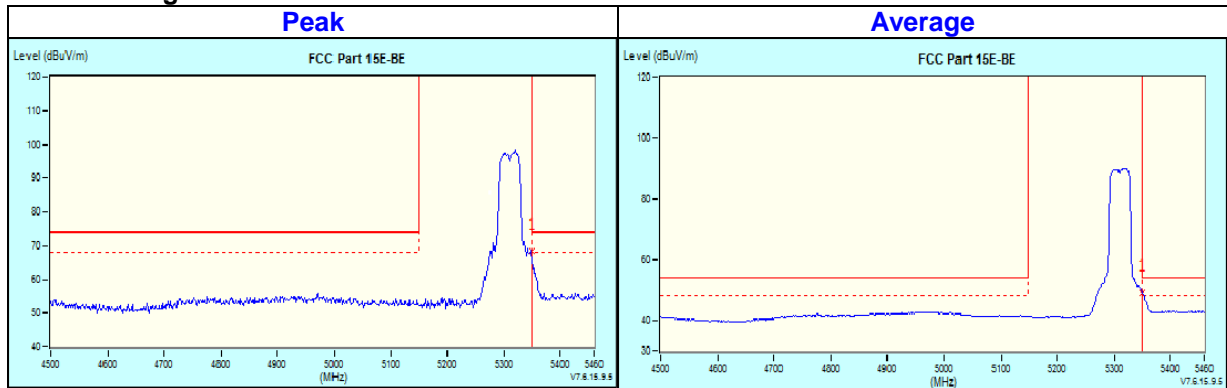

CHANNEL	TX Channel 102	DETECTOR FUNCTION	Peak (PK)
FREQUENCY RANGE	1GHz ~ 40GHz		Average (AV)

ANTENNA POLARITY & TEST DISTANCE: HORIZONTAL AT 3 M

NO.	FREQ. (MHz)	EMISSION LEVEL (dBuV/m)	LIMIT (dBuV/m)	MARGIN (dB)	ANTENNA HEIGHT (m)	TABLE ANGLE (Degree)	RAW VALUE (dBuV)	CORRECTION FACTOR (dB/m)
1	5460.00	57.3 PK	74.0	-16.7	3.57 H	310	53.2	4.1
2	5460.00	43.4 AV	54.0	-10.6	3.57 H	310	39.3	4.1
3	#5470.00	63.0 PK	68.2	-5.2	3.46 H	355	58.9	4.1
4	*5510.00	97.4 PK			3.64 H	266	57.5	39.9
5	*5510.00	87.3 AV			3.64 H	266	47.4	39.9
6	11020.00	60.4 PK	74.0	-13.6	1.29 H	49	42.3	18.1
7	11020.00	47.0 AV	54.0	-7.0	1.29 H	49	28.9	18.1

Remarks:

1. Emission Level(dBuV/m) = Raw Value(dBuV) + Correction Factor(dB/m)
2. Correction Factor(dB/m) = Antenna Factor(dB/m) + Cable Factor(dB) – Pre-Amplifier Factor(dB)
3. The other emission levels were very low against the limit
4. Margin value = Emission Level – Limit value
5. " * ": Fundamental frequency

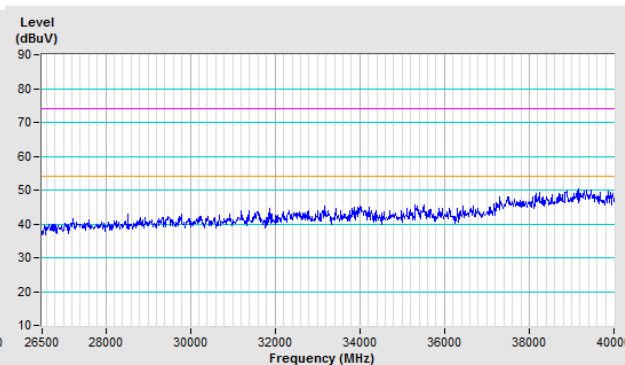
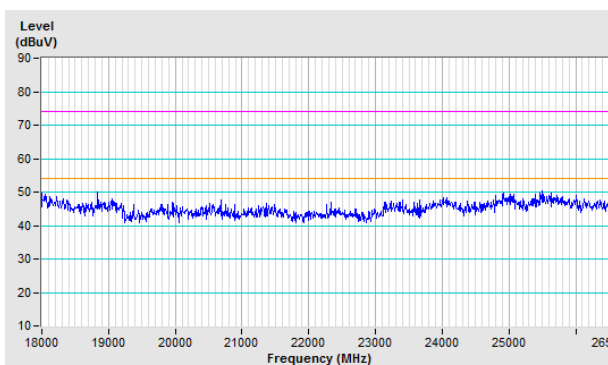
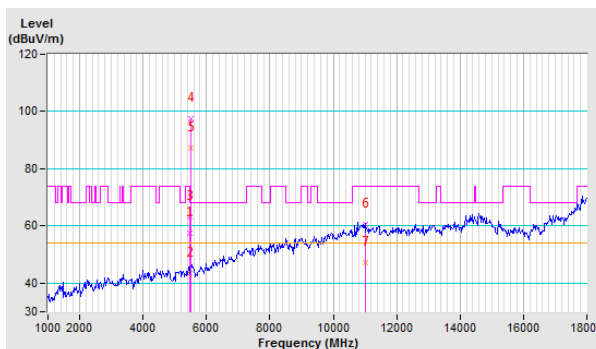

For Bandedge

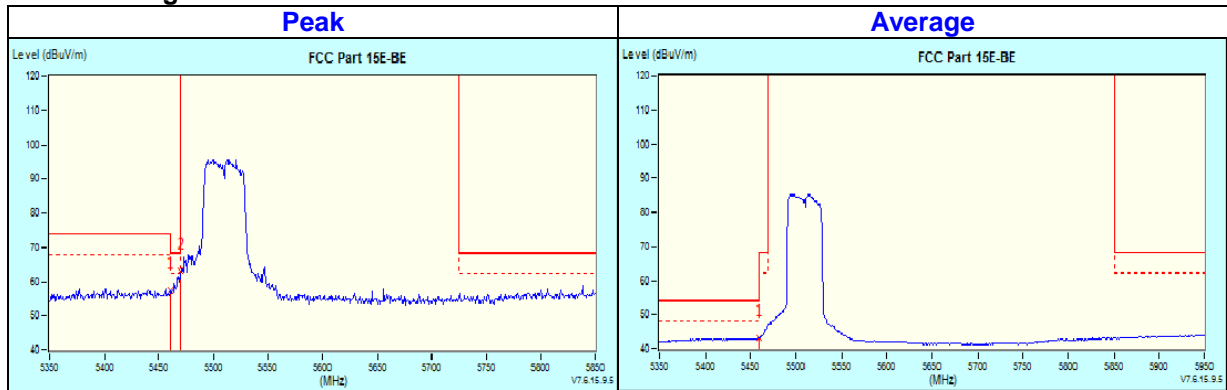

CHANNEL	TX Channel 102	DETECTOR FUNCTION	Peak (PK) Average (AV)
FREQUENCY RANGE	1GHz ~ 40GHz		

ANTENNA POLARITY & TEST DISTANCE: VERTICAL AT 3 M								
NO.	FREQ. (MHz)	EMISSION LEVEL (dBuV/m)	LIMIT (dBuV/m)	MARGIN (dB)	ANTENNA HEIGHT (m)	TABLE ANGLE (Degree)	RAW VALUE (dBuV)	CORRECTION FACTOR (dB/m)
1	5460.00	56.9 PK	74.0	-17.1	1.09 V	60	52.8	4.1
2	5460.00	43.4 AV	54.0	-10.6	1.09 V	60	39.3	4.1
3	#5470.00	64.5 PK	68.2	-3.7	1.03 V	58	60.4	4.1
4	*5510.00	99.8 PK			1.11 V	47	59.9	39.9
5	*5510.00	89.9 AV			1.11 V	47	50.0	39.9
6	11020.00	60.2 PK	74.0	-13.8	1.56 V	322	42.1	18.1
7	11020.00	47.1 AV	54.0	-6.9	1.56 V	322	29.0	18.1

Remarks:

1. Emission Level(dBuV/m) = Raw Value(dBuV) + Correction Factor(dB/m)
2. Correction Factor(dB/m) = Antenna Factor(dB/m) + Cable Factor(dB) – Pre-Amplifier Factor(dB)
3. The other emission levels were very low against the limit
4. Margin value = Emission Level – Limit value
5. " * ": Fundamental frequency

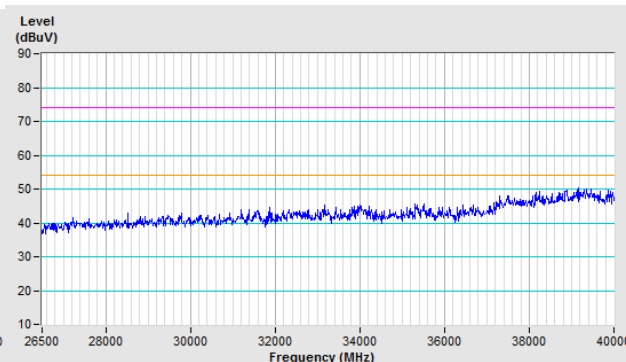
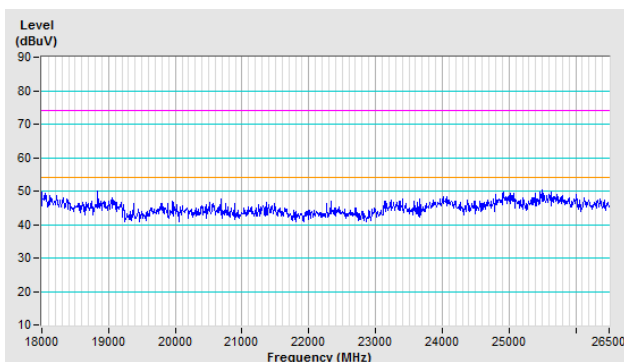
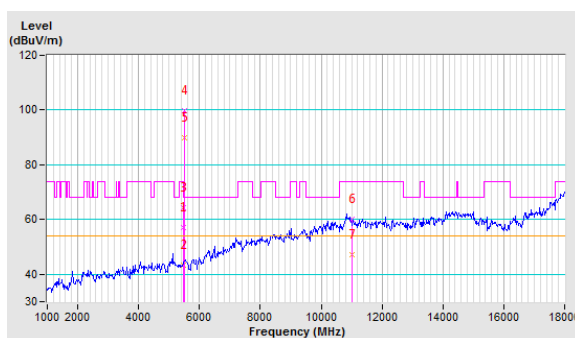

For Bandedge

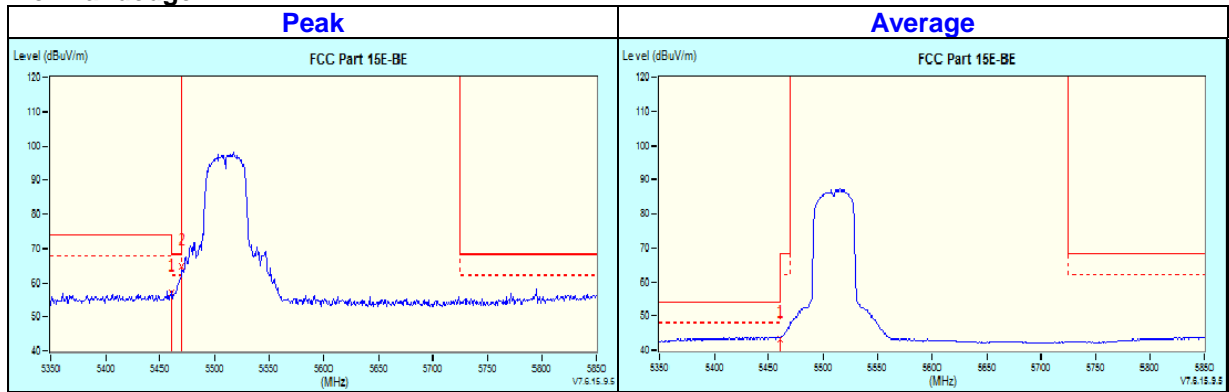

CHANNEL	TX Channel 110	DETECTOR FUNCTION	Peak (PK)
FREQUENCY RANGE	1GHz ~ 40GHz		Average (AV)

ANTENNA POLARITY & TEST DISTANCE: HORIZONTAL AT 3 M

NO.	FREQ. (MHz)	EMISSION LEVEL (dBuV/m)	LIMIT (dBuV/m)	MARGIN (dB)	ANTENNA HEIGHT (m)	TABLE ANGLE (Degree)	RAW VALUE (dBuV)	CORRECTION FACTOR (dB/m)
1	5460.00	57.1 PK	74.0	-16.9	3.54 H	59	53.0	4.1
2	5460.00	43.2 AV	54.0	-10.8	3.54 H	59	39.1	4.1
3	#5470.00	56.5 PK	68.2	-11.7	3.39 H	60	52.4	4.1
4	*5550.00	97.5 PK			3.61 H	53	57.7	39.8
5	*5550.00	87.5 AV			3.61 H	53	47.7	39.8
6	11100.00	58.7 PK	74.0	-15.3	1.35 H	45	41.1	17.6
7	11100.00	45.5 AV	54.0	-8.5	1.35 H	45	27.9	17.6

Remarks:

1. Emission Level(dBuV/m) = Raw Value(dBuV) + Correction Factor(dB/m)
2. Correction Factor(dB/m) = Antenna Factor(dB/m) + Cable Factor(dB) – Pre-Amplifier Factor(dB)
3. The other emission levels were very low against the limit
4. Margin value = Emission Level – Limit value
5. " * ": Fundamental frequency

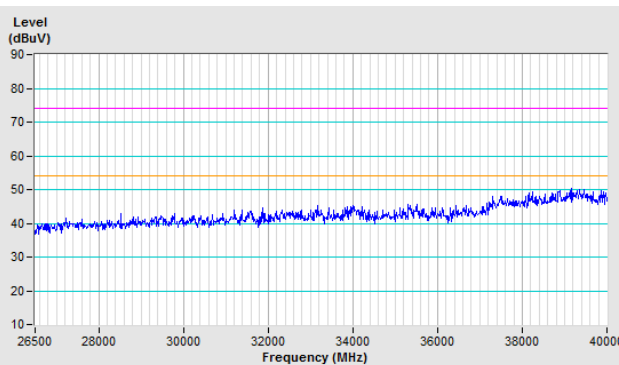
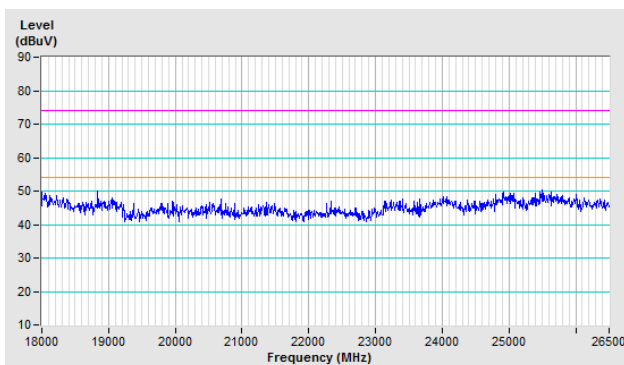
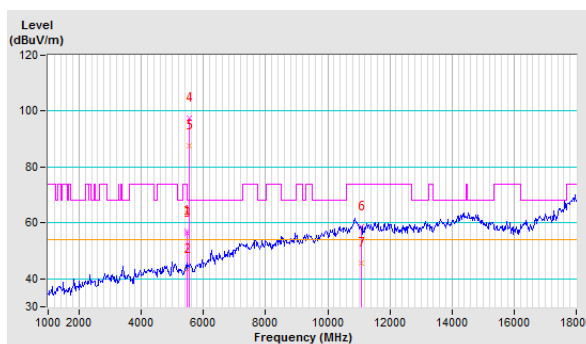

For Bandedge

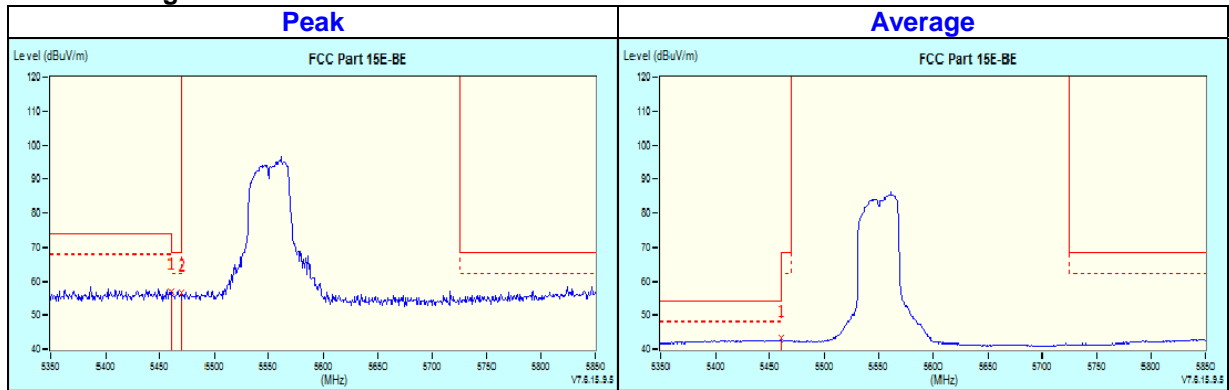

CHANNEL	TX Channel 110	DETECTOR FUNCTION	Peak (PK)
FREQUENCY RANGE	1GHz ~ 40GHz		Average (AV)

ANTENNA POLARITY & TEST DISTANCE: VERTICAL AT 3 M								
NO.	FREQ. (MHz)	EMISSION LEVEL (dBuV/m)	LIMIT (dBuV/m)	MARGIN (dB)	ANTENNA HEIGHT (m)	TABLE ANGLE (Degree)	RAW VALUE (dBuV)	CORRECTION FACTOR (dB/m)
1	5460.00	56.1 PK	74.0	-17.9	1.19 V	49	52.0	4.1
2	5460.00	43.1 AV	54.0	-10.9	1.19 V	49	39.0	4.1
3	#5470.00	56.2 PK	68.2	-12.0	1.21 V	44	52.1	4.1
4	*5550.00	100.6 PK			1.16 V	52	60.8	39.8
5	*5550.00	90.6 AV			1.16 V	52	50.8	39.8
6	11100.00	59.7 PK	74.0	-14.3	1.44 V	317	42.1	17.6
7	11100.00	46.1 AV	54.0	-7.9	1.44 V	317	28.5	17.6

Remarks:

1. Emission Level(dBuV/m) = Raw Value(dBuV) + Correction Factor(dB/m)
2. Correction Factor(dB/m) = Antenna Factor(dB/m) + Cable Factor(dB) – Pre-Amplifier Factor(dB)
3. The other emission levels were very low against the limit
4. Margin value = Emission Level – Limit value
5. " * ": Fundamental frequency

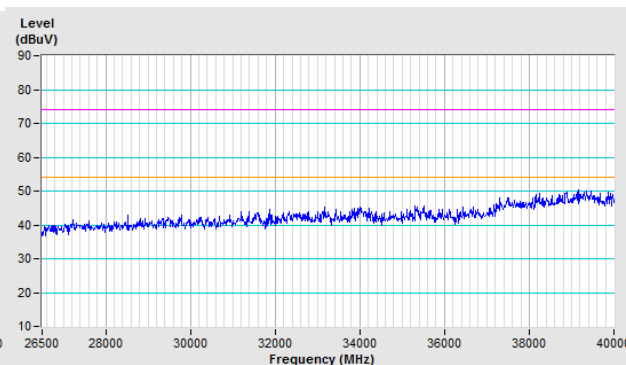
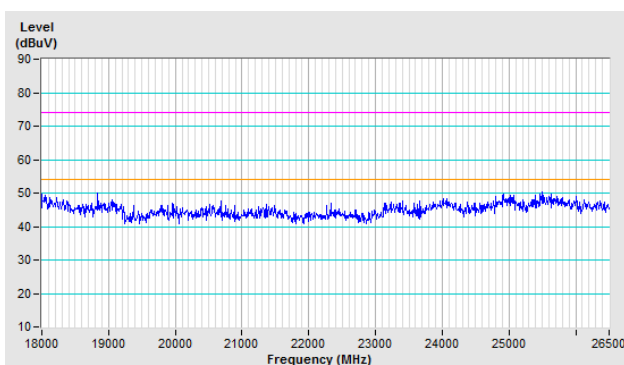
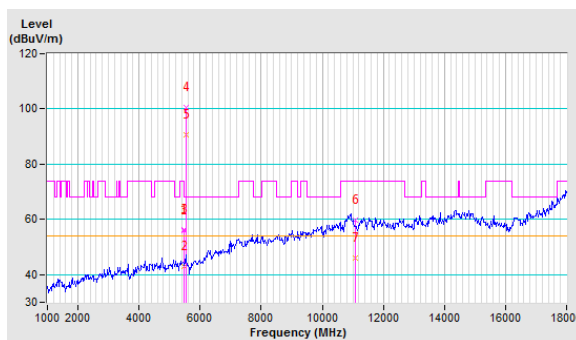

For Bandedge

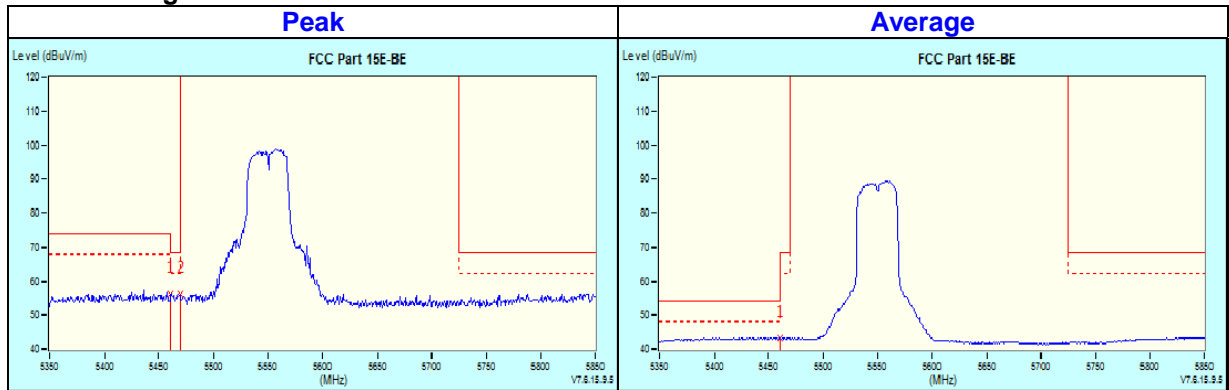

CHANNEL	TX Channel 134	DETECTOR FUNCTION	Peak (PK)
FREQUENCY RANGE	1GHz ~ 40GHz		Average (AV)

ANTENNA POLARITY & TEST DISTANCE: HORIZONTAL AT 3 M								
NO.	FREQ. (MHz)	EMISSION LEVEL (dBuV/m)	LIMIT (dBuV/m)	MARGIN (dB)	ANTENNA HEIGHT (m)	TABLE ANGLE (Degree)	RAW VALUE (dBuV)	CORRECTION FACTOR (dB/m)
1	*5670.00	96.7 PK			3.62 H	252	56.9	39.8
2	*5670.00	86.9 AV			3.62 H	252	47.1	39.8
3	#5725.00	56.1 PK	68.2	-12.1	3.71 H	269	51.7	4.4
4	11340.00	61.3 PK	74.0	-12.7	1.19 H	51	43.9	17.4
5	11340.00	48.4 AV	54.0	-5.6	1.19 H	51	31.0	17.4

Remarks:

1. Emission Level(dBuV/m) = Raw Value(dBuV) + Correction Factor(dB/m)
2. Correction Factor(dB/m) = Antenna Factor(dB/m) + Cable Factor(dB) – Pre-Amplifier Factor(dB)
3. The other emission levels were very low against the limit
4. Margin value = Emission Level – Limit value
5. " * ": Fundamental frequency

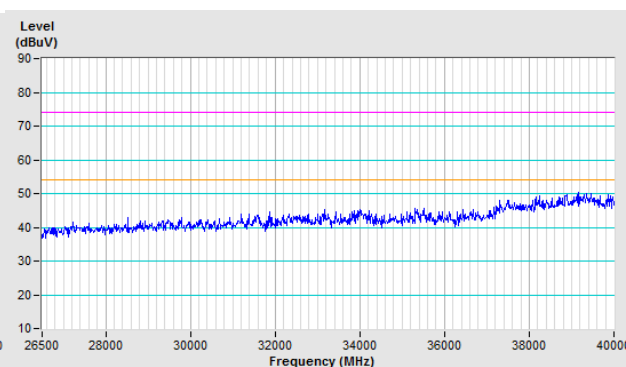
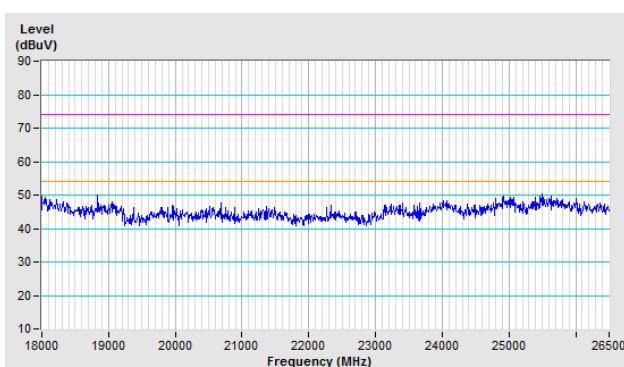
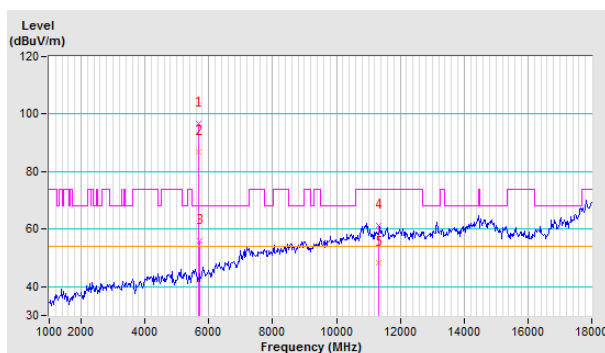

For Bandedge

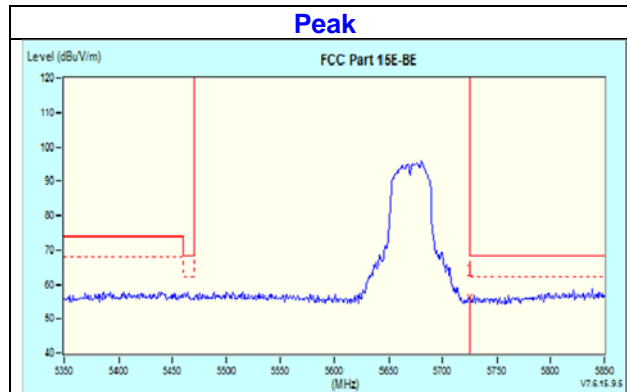

CHANNEL	TX Channel 134	DETECTOR FUNCTION	Peak (PK) Average (AV)
FREQUENCY RANGE	1GHz ~ 40GHz		

ANTENNA POLARITY & TEST DISTANCE: VERTICAL AT 3 M								
NO.	FREQ. (MHz)	EMISSION LEVEL (dBuV/m)	LIMIT (dBuV/m)	MARGIN (dB)	ANTENNA HEIGHT (m)	TABLE ANGLE (Degree)	RAW VALUE (dBuV)	CORRECTION FACTOR (dB/m)
1	*5670.00	100.3 PK			1.13 V	52	60.5	39.8
2	*5670.00	91.0 AV			1.13 V	52	51.2	39.8
3	#5725.00	57.9 PK	68.2	-10.3	1.24 V	55	53.5	4.4
4	11340.00	62.9 PK	74.0	-11.1	1.11 V	314	45.5	17.4
5	11340.00	50.2 AV	54.0	-3.8	1.11 V	314	32.8	17.4

Remarks:

1. Emission Level(dBuV/m) = Raw Value(dBuV) + Correction Factor(dB/m)
2. Correction Factor(dB/m) = Antenna Factor(dB/m) + Cable Factor(dB) – Pre-Amplifier Factor(dB)
3. The other emission levels were very low against the limit
4. Margin value = Emission Level – Limit value
5. " * ": Fundamental frequency

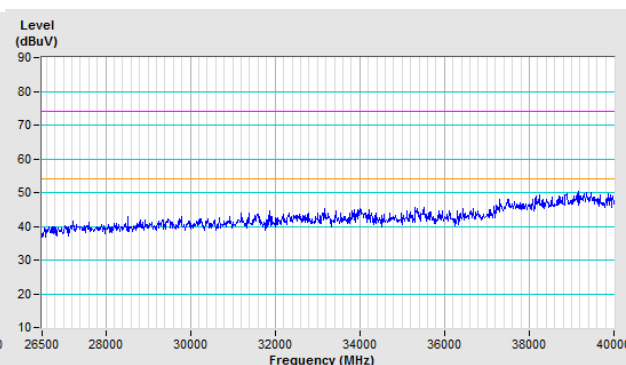
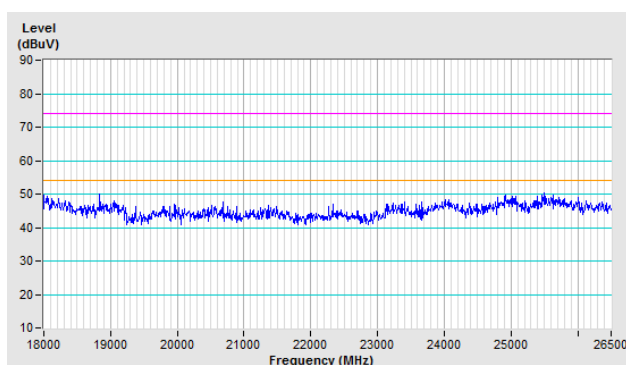
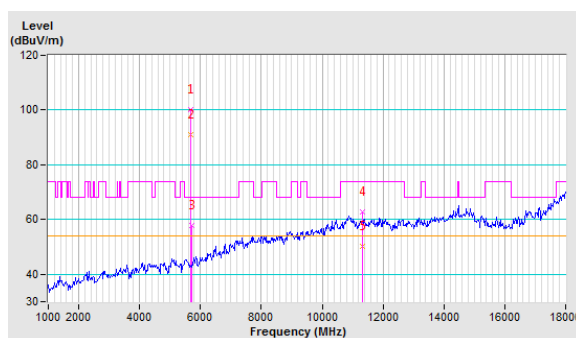

For Bandedge

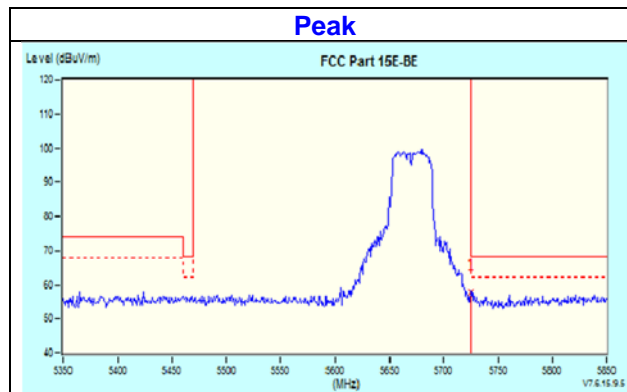

CHANNEL	TX Channel 151	DETECTOR FUNCTION	Peak (PK)
FREQUENCY RANGE	1GHz ~ 40GHz		Average (AV)

ANTENNA POLARITY & TEST DISTANCE: HORIZONTAL AT 3 M								
NO.	FREQ. (MHz)	EMISSION LEVEL (dBuV/m)	LIMIT (dBuV/m)	MARGIN (dB)	ANTENNA HEIGHT (m)	TABLE ANGLE (Degree)	RAW VALUE (dBuV)	CORRECTION FACTOR (dB/m)
1	#5626.28	55.6 PK	68.2	-12.6	3.63 H	62	51.4	4.2
2	*5755.00	98.3 PK			3.63 H	62	58.2	40.1
3	*5755.00	89.0 AV			3.63 H	62	48.9	40.1
4	#5943.59	58.0 PK	68.2	-10.2	3.63 H	62	53.1	4.9
5	11510.00	61.1 PK	74.0	-12.9	1.31 H	49	43.4	17.7
6	11510.00	48.2 AV	54.0	-5.8	1.31 H	49	30.5	17.7

Remarks:

1. Emission Level(dBuV/m) = Raw Value(dBuV) + Correction Factor(dB/m)
2. Correction Factor(dB/m) = Antenna Factor(dB/m) + Cable Factor(dB) – Pre-Amplifier Factor(dB)
3. The other emission levels were very low against the limit
4. Margin value = Emission Level – Limit value
5. " * ": Fundamental frequency

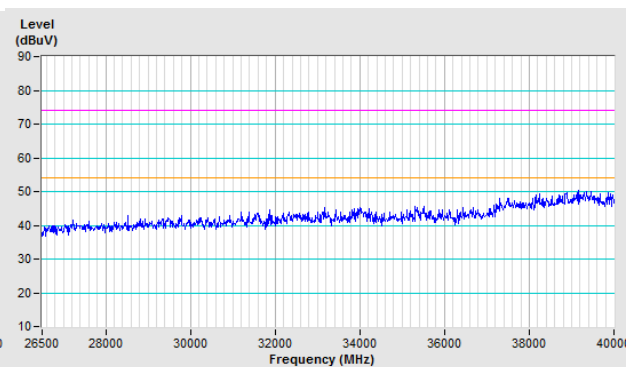
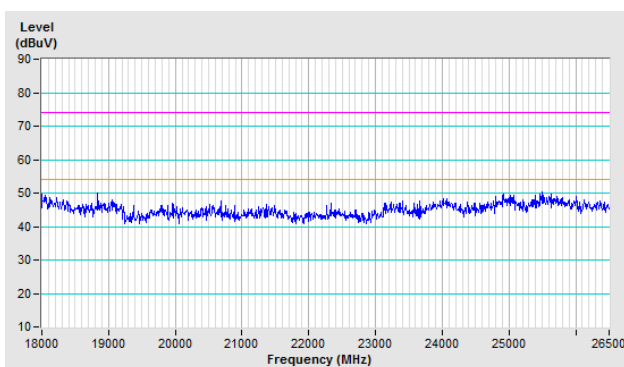
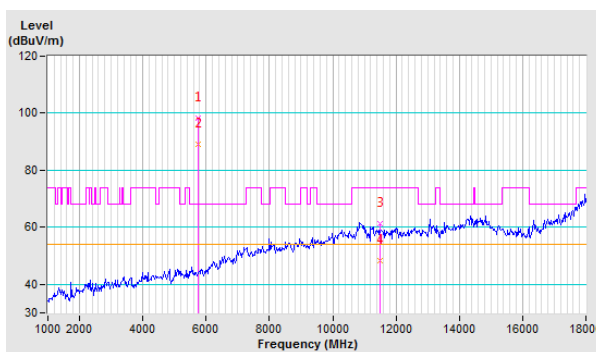

For Bandedge

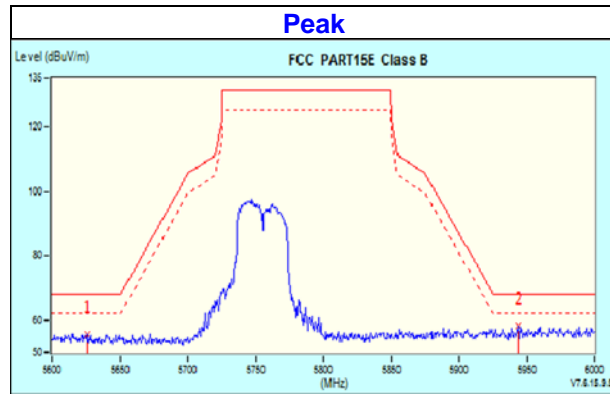

CHANNEL	TX Channel 151	DETECTOR FUNCTION	Peak (PK) Average (AV)
FREQUENCY RANGE	1GHz ~ 40GHz		

ANTENNA POLARITY & TEST DISTANCE: VERTICAL AT 3 M								
NO.	FREQ. (MHz)	EMISSION LEVEL (dBuV/m)	LIMIT (dBuV/m)	MARGIN (dB)	ANTENNA HEIGHT (m)	TABLE ANGLE (Degree)	RAW VALUE (dBuV)	CORRECTION FACTOR (dB/m)
1	#5646.79	57.2 PK	68.2	-11.0	1.43 V	55	53.0	4.2
2	*5755.00	100.1 PK			1.43 V	55	60.0	40.1
3	*5755.00	90.2 AV			1.43 V	55	50.1	40.1
4	#5939.10	59.1 PK	68.2	-9.1	1.43 V	55	54.2	4.9
5	11510.00	62.6 PK	74.0	-11.4	1.23 V	349	44.9	17.7
6	11510.00	49.3 AV	54.0	-4.7	1.23 V	349	31.6	17.7

Remarks:

1. Emission Level(dBuV/m) = Raw Value(dBuV) + Correction Factor(dB/m)
2. Correction Factor(dB/m) = Antenna Factor(dB/m) + Cable Factor(dB) – Pre-Amplifier Factor(dB)
3. The other emission levels were very low against the limit
4. Margin value = Emission Level – Limit value
5. " * ": Fundamental frequency

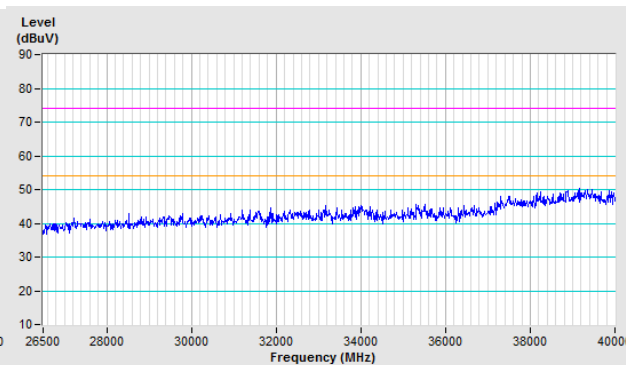
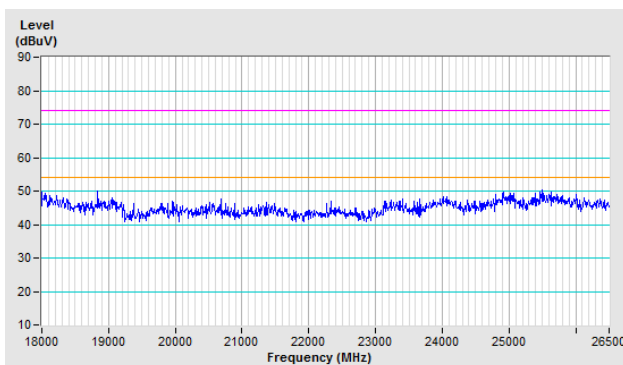
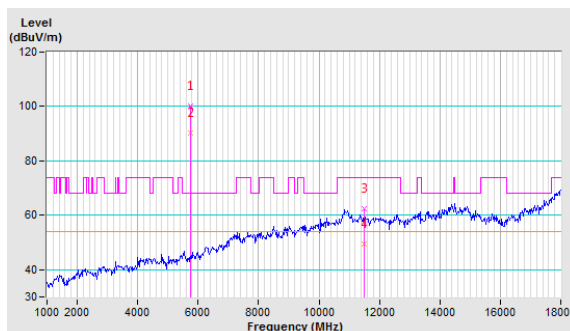

For Bandedge

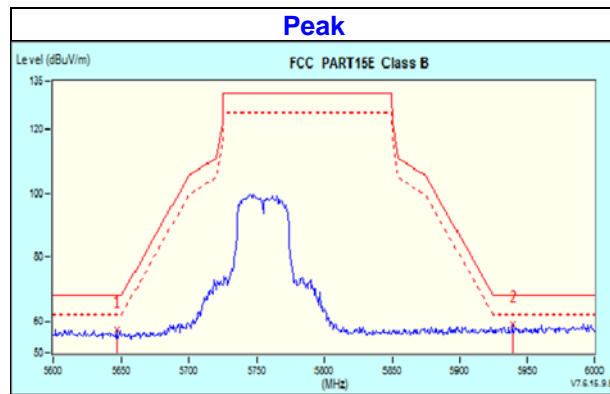

CHANNEL	TX Channel 159	DETECTOR FUNCTION	Peak (PK)
FREQUENCY RANGE	1GHz ~ 40GHz		Average (AV)

ANTENNA POLARITY & TEST DISTANCE: HORIZONTAL AT 3 M								
NO.	FREQ. (MHz)	EMISSION LEVEL (dBuV/m)	LIMIT (dBuV/m)	MARGIN (dB)	ANTENNA HEIGHT (m)	TABLE ANGLE (Degree)	RAW VALUE (dBuV)	CORRECTION FACTOR (dB/m)
1	#5638.46	56.2 PK	68.2	-12.0	3.62 H	259	52.0	4.2
2	*5795.00	96.8 PK			3.62 H	259	56.4	40.4
3	*5795.00	86.2 AV			3.62 H	259	45.8	40.4
4	#5967.95	58.4 PK	68.2	-9.8	3.62 H	259	53.4	5.0
5	11590.00	60.7 PK	74.0	-13.3	1.21 H	39	43.2	17.5
6	11590.00	47.6 AV	54.0	-6.4	1.21 H	39	30.1	17.5

Remarks:

1. Emission Level(dBuV/m) = Raw Value(dBuV) + Correction Factor(dB/m)
2. Correction Factor(dB/m) = Antenna Factor(dB/m) + Cable Factor(dB) – Pre-Amplifier Factor(dB)
3. The other emission levels were very low against the limit
4. Margin value = Emission Level – Limit value
5. " * ": Fundamental frequency

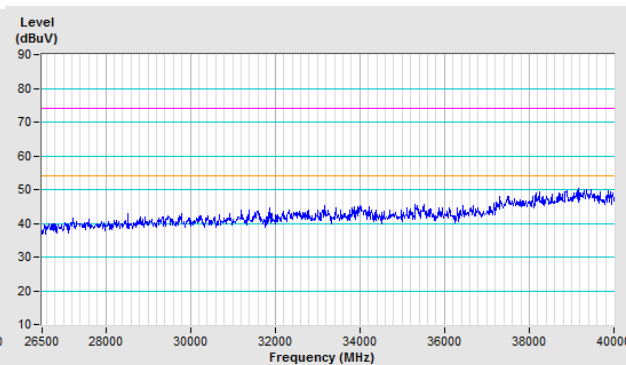
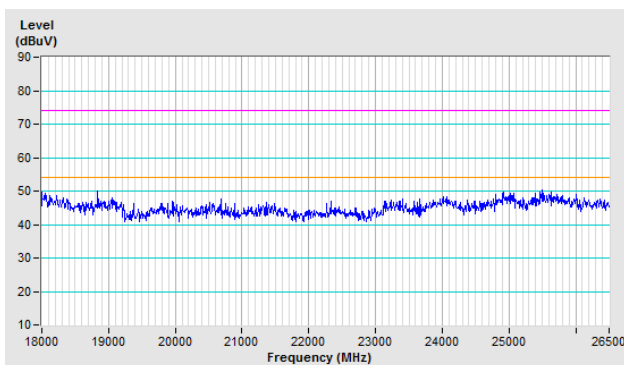
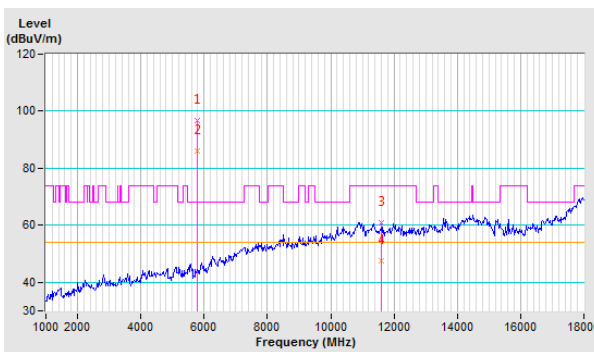

For Bandedge

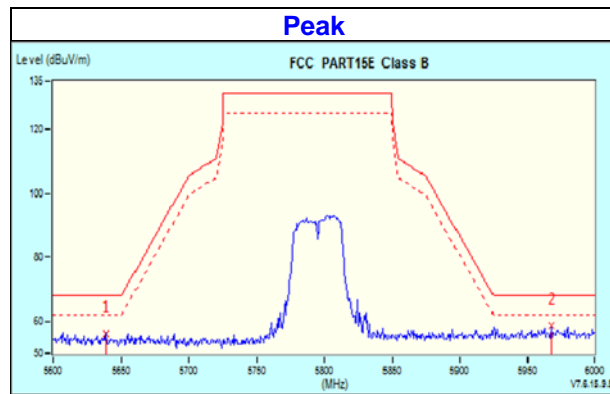

CHANNEL	TX Channel 159	DETECTOR FUNCTION	Peak (PK)
FREQUENCY RANGE	1GHz ~ 40GHz		Average (AV)

ANTENNA POLARITY & TEST DISTANCE: VERTICAL AT 3 M								
NO.	FREQ. (MHz)	EMISSION LEVEL (dBuV/m)	LIMIT (dBuV/m)	MARGIN (dB)	ANTENNA HEIGHT (m)	TABLE ANGLE (Degree)	RAW VALUE (dBuV)	CORRECTION FACTOR (dB/m)
1	#5648.72	55.5 PK	68.2	-12.7	1.19 V	57	51.3	4.2
2	*5795.00	100.4 PK			1.19 V	57	60.0	40.4
3	*5795.00	90.2 AV			1.19 V	57	49.8	40.4
4	#5948.08	57.9 PK	68.2	-10.3	1.19 V	57	53.0	4.9
5	11590.00	62.0 PK	74.0	-12.0	1.31 V	351	44.5	17.5
6	11590.00	48.8 AV	54.0	-5.2	1.31 V	351	31.3	17.5

Remarks:

1. Emission Level(dBuV/m) = Raw Value(dBuV) + Correction Factor(dB/m)
2. Correction Factor(dB/m) = Antenna Factor(dB/m) + Cable Factor(dB) – Pre-Amplifier Factor(dB)
3. The other emission levels were very low against the limit
4. Margin value = Emission Level – Limit value
5. " * ": Fundamental frequency

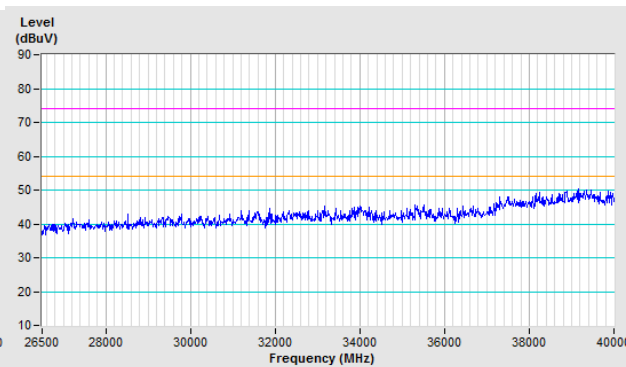
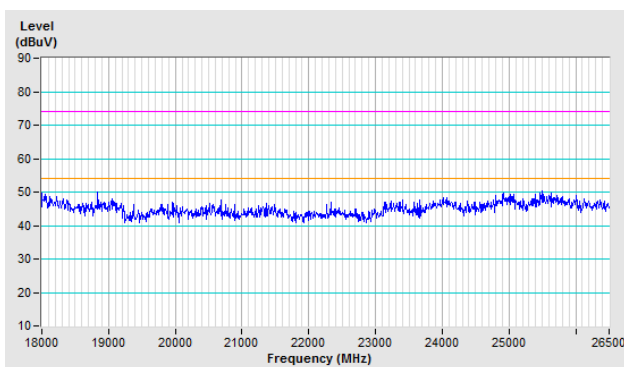
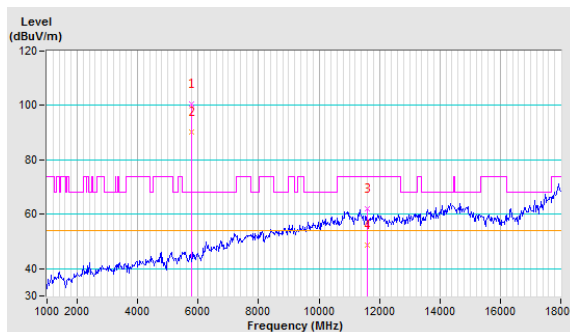

For Bandedge

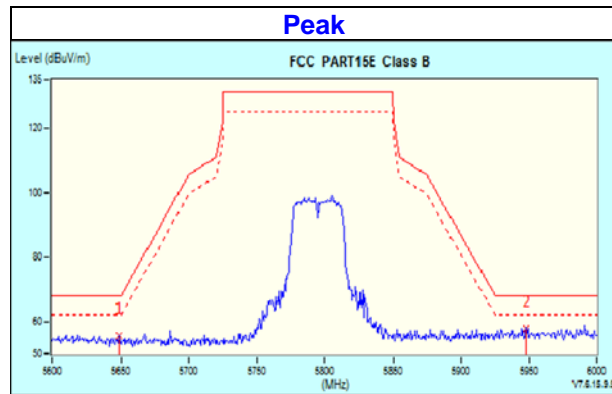

4.1.8 Test Results for below 1GHz

802.11a

CHANNEL	TX Channel 116	DETECTOR FUNCTION	Peak (PK)
FREQUENCY RANGE	30MHz ~ 1GHz	TEST MODE	A

ANTENNA POLARITY & TEST DISTANCE: HORIZONTAL AT 3 M								
NO.	FREQ. (MHz)	EMISSION LEVEL (dBuV/m)	LIMIT (dBuV/m)	MARGIN (dB)	ANTENNA HEIGHT (m)	TABLE ANGLE (Degree)	RAW VALUE (dBuV)	CORRECTION FACTOR (dB/m)
1	117.39	39.3 PK	43.5	-4.2	1.01 H	15	51.1	-11.8
2	166.00	35.8 PK	43.5	-7.7	1.51 H	108	44.9	-9.1
3	245.72	39.4 PK	46.0	-6.6	1.01 H	63	48.7	-9.3
4	335.15	29.8 PK	46.0	-16.2	1.01 H	30	36.5	-6.7
5	432.37	30.9 PK	46.0	-15.1	1.01 H	340	35.4	-4.5
6	537.36	33.9 PK	46.0	-12.1	1.51 H	162	37.0	-3.1

Remarks:

1. Emission Level(dBuV/m) = Raw Value(dBuV) + Correction Factor(dB/m)
2. Correction Factor(dB/m) = Antenna Factor(dB/m) + Cable Factor(dB) – Pre-Amplifier Factor(dB)
3. The other emission levels were very low against the limit of frequency range 30MHz ~ 1000MHz
4. Margin value = Emission Level – Limit value
5. The emission levels were very low against the limit of frequency range 9kHz ~ 30MHz: the amplitude of spurious emissions attenuated more than 20 dB below the permissible value to be report
6. The PK detector measurement value is much smaller than the limit QP value, so the pass is determined

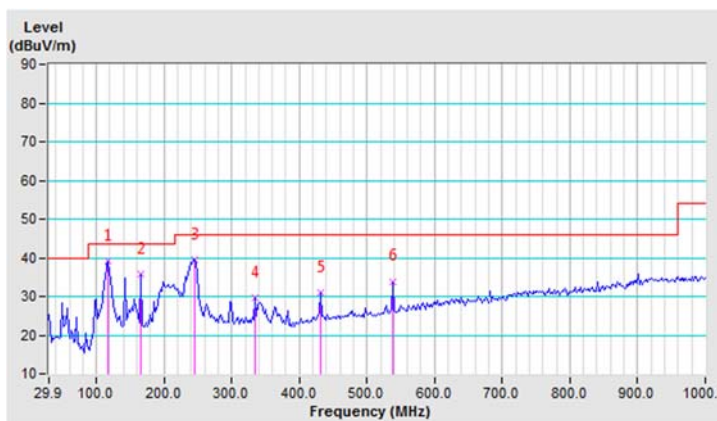

CHANNEL	TX Channel 116	DETECTOR FUNCTION	Peak (PK)
FREQUENCY RANGE	30MHz ~ 1GHz	TEST MODE	A

ANTENNA POLARITY & TEST DISTANCE: VERTICAL AT 3 M								
NO.	FREQ. (MHz)	EMISSION LEVEL (dBuV/m)	LIMIT (dBuV/m)	MARGIN (dB)	ANTENNA HEIGHT (m)	TABLE ANGLE (Degree)	RAW VALUE (dBuV)	CORRECTION FACTOR (dB/m)
1	59.06	34.1 PK	40.0	-5.9	1.49 V	330	44.2	-10.1
2	99.89	34.2 PK	43.5	-9.3	1.00 V	63	47.8	-13.6
3	117.39	34.7 PK	43.5	-8.8	1.00 V	219	46.5	-11.8
4	239.88	37.0 PK	46.0	-9.0	2.00 V	110	46.6	-9.6
5	335.15	31.5 PK	46.0	-14.5	1.49 V	85	38.2	-6.7
6	486.81	30.7 PK	46.0	-15.3	1.00 V	200	34.6	-3.9

Remarks:

1. Emission Level(dBuV/m) = Raw Value(dBuV) + Correction Factor(dB/m)
2. Correction Factor(dB/m) = Antenna Factor(dB/m) + Cable Factor(dB) – Pre-Amplifier Factor(dB)
3. The other emission levels were very low against the limit of frequency range 30MHz ~ 1000MHz
4. Margin value = Emission Level – Limit value
5. The emission levels were very low against the limit of frequency range 9kHz ~ 30MHz: the amplitude of spurious emissions attenuated more than 20 dB below the permissible value to be report
6. The PK detector measurement value is much smaller than the limit QP value, so the pass is determined

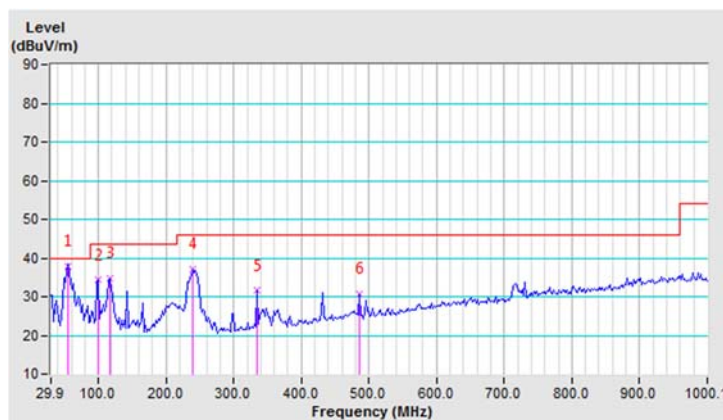

CHANNEL	TX Channel 116	DETECTOR FUNCTION	Peak (PK)
FREQUENCY RANGE	30MHz ~ 1GHz	TEST MODE	B

ANTENNA POLARITY & TEST DISTANCE: HORIZONTAL AT 3 M								
NO.	FREQ. (MHz)	EMISSION LEVEL (dBuV/m)	LIMIT (dBuV/m)	MARGIN (dB)	ANTENNA HEIGHT (m)	TABLE ANGLE (Degree)	RAW VALUE (dBuV)	CORRECTION FACTOR (dB/m)
1	56.33	27.7 PK	40.0	-12.3	1.99 H	358	37.7	-10.0
2	93.65	22.9 PK	43.5	-20.6	1.49 H	228	37.3	-14.4
3	155.84	23.6 PK	43.5	-19.9	1.99 H	195	32.7	-9.1
4	199.37	30.6 PK	43.5	-12.9	1.49 H	243	41.8	-11.2
5	323.76	23.9 PK	46.0	-22.1	1.00 H	92	30.7	-6.8
6	580.30	28.9 PK	46.0	-17.1	1.49 H	123	30.7	-1.8

Remarks:

1. Emission Level(dBuV/m) = Raw Value(dBuV) + Correction Factor(dB/m)
2. Correction Factor(dB/m) = Antenna Factor(dB/m) + Cable Factor(dB) – Pre-Amplifier Factor(dB)
3. The other emission levels were very low against the limit of frequency range 30MHz ~ 1000MHz
4. Margin value = Emission Level – Limit value
5. The emission levels were very low against the limit of frequency range 9kHz ~ 30MHz: the amplitude of spurious emissions attenuated more than 20 dB below the permissible value to be report
6. The PK detector measurement value is much smaller than the limit QP value, so the pass is determined

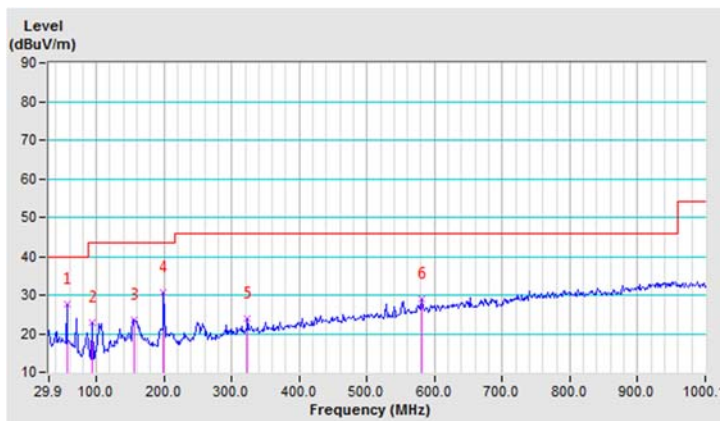

CHANNEL	TX Channel 116	DETECTOR FUNCTION	Peak (PK)
FREQUENCY RANGE	30MHz ~ 1GHz	TEST MODE	B

ANTENNA POLARITY & TEST DISTANCE: VERTICAL AT 3 M								
NO.	FREQ. (MHz)	EMISSION LEVEL (dBuV/m)	LIMIT (dBuV/m)	MARGIN (dB)	ANTENNA HEIGHT (m)	TABLE ANGLE (Degree)	RAW VALUE (dBuV)	CORRECTION FACTOR (dB/m)
1	29.90	29.4 PK	40.0	-10.6	1.01 V	310	40.9	-11.5
2	40.78	26.2 PK	40.0	-13.8	1.01 V	2	36.4	-10.2
3	90.54	23.0 PK	43.5	-20.5	1.51 V	144	37.6	-14.6
4	102.98	23.7 PK	43.5	-19.8	1.51 V	100	36.9	-13.2
5	404.61	24.6 PK	46.0	-21.4	1.01 V	280	30.1	-5.5
6	528.99	28.3 PK	46.0	-17.7	1.01 V	255	31.5	-3.2

Remarks:

1. Emission Level(dBuV/m) = Raw Value(dBuV) + Correction Factor(dB/m)
2. Correction Factor(dB/m) = Antenna Factor(dB/m) + Cable Factor(dB) – Pre-Amplifier Factor(dB)
3. The other emission levels were very low against the limit of frequency range 30MHz ~ 1000MHz
4. Margin value = Emission Level – Limit value
5. The emission levels were very low against the limit of frequency range 9kHz ~ 30MHz: the amplitude of spurious emissions attenuated more than 20 dB below the permissible value to be report
6. The PK detector measurement value is much smaller than the limit QP value, so the pass is determined

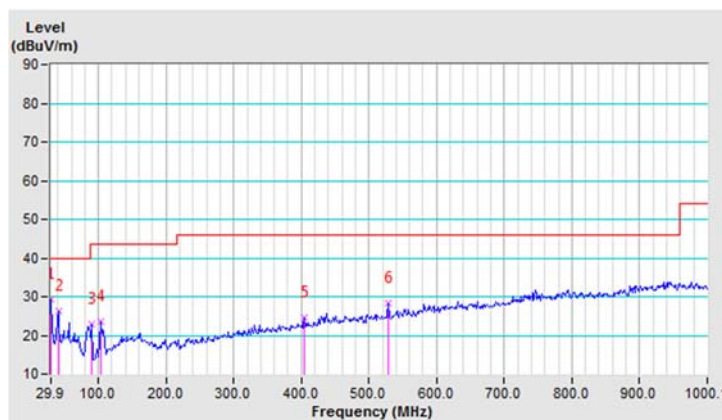

4.2 Conducted Emission Measurement

4.2.1 Limits of Conducted Emission Measurement

Frequency (MHz)	Conducted Limit (dBuV)	
	Quasi-peak	Average
0.15 - 0.5	66 - 56	56 - 46
0.50 - 5.0	56	46
5.0 - 30.0	60	50

Note: 1. The lower limit shall apply at the transition frequencies.

2. The limit decreases in line with the logarithm of the frequency in the range of 0.15 to 0.50MHz.

4.2.2 Test Instruments

Description & Manufacturer	Model No.	Serial No.	Cal. Date	Cal. Due
Test Receiver ROHDE & SCHWARZ	ESCS30	100291	Sep. 03, 2018	Sep. 02, 2019
RF signal cable Woken	5D-FB	Cable-cond1-01	Sep. 05, 2018	Sep. 04, 2019
LISN ROHDE & SCHWARZ (EUT)	ENV216	101826	Feb. 26, 2018	Feb. 25, 2019
LISN ROHDE & SCHWARZ (Peripheral)	ESH3-Z5	100311	Aug. 19, 2018	Aug. 18, 2019
Software ADT	BV ADT_Cond_ V7.3.7.4	NA	NA	NA

Note: 1. The calibration interval of the above test instruments is 12 months and the calibrations are traceable to NML/ROC and NIST/USA.

2. The test was performed in HwaYa Shielded Room 1.

3. The VCCI Site Registration No. is C-2040.

4.2.3 Test Procedures

- The EUT was placed 0.4 meters from the conducting wall of the shielded room with EUT being connected to the power mains through a line impedance stabilization network (LISN). Other support units were connected to the power mains through another LISN. The two LISNs provide 50 ohm/ 50uH of coupling impedance for the measuring instrument.
- Both lines of the power mains connected to the EUT were checked for maximum conducted interference.
- The frequency range from 150kHz to 30MHz was searched. Emission levels under (Limit - 20dB) was not recorded.

NOTE: The resolution bandwidth and video bandwidth of test receiver is 9kHz for quasi-peak detection (QP) and average detection (AV) at frequency 0.15MHz-30MHz.

4.2.4 Deviation from Test Standard

No deviation.

4.2.5 Test Setup

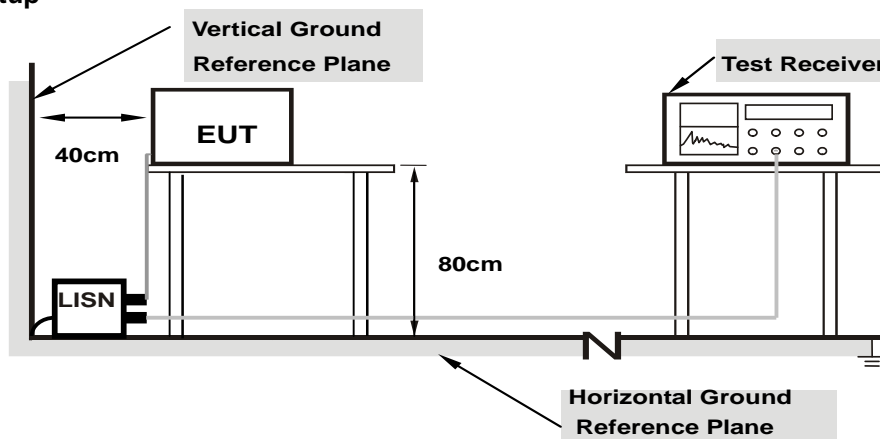

Note: 1.Support units were connected to second LISN.

For the actual test configuration, please refer to the attached file (Test Setup Photo).

4.2.6 EUT Operating Conditions

Same as 4.1.6.

4.2.7 Test Results

Phase	Line (L)	Detector Function	Quasi-Peak (QP) / Average (AV)
Test Mode	A		

No	Freq. [MHz]	Corr. Factor (dB)	Reading Value		Emission Level		Limit		Margin	
			[dB (uV)]		[dB (uV)]		[dB (uV)]		(dB)	
			Q.P.	AV.	Q.P.	AV.	Q.P.	AV.	Q.P.	AV.
1	0.15391	9.67	43.64	27.79	53.31	37.46	65.79	55.79	-12.48	-18.33
2	0.24375	9.67	31.40	18.04	41.07	27.71	61.97	51.97	-20.90	-24.26
3	0.95469	9.65	11.32	3.75	20.97	13.40	56.00	46.00	-35.03	-32.60
4	1.87500	9.68	17.04	11.26	26.72	20.94	56.00	46.00	-29.28	-25.06
5	3.83984	9.73	20.55	9.14	30.28	18.87	56.00	46.00	-25.72	-27.13
6	26.48828	9.92	13.99	8.86	23.91	18.78	60.00	50.00	-36.09	-31.22

REMARKS:

1. Q.P. and AV. are abbreviations of quasi-peak and average individually.
2. The emission levels of other frequencies were very low against the limit.
3. Margin value = Emission level - Limit value
4. Correction factor = Insertion loss + Cable loss
5. Emission Level = Correction Factor + Reading Value.

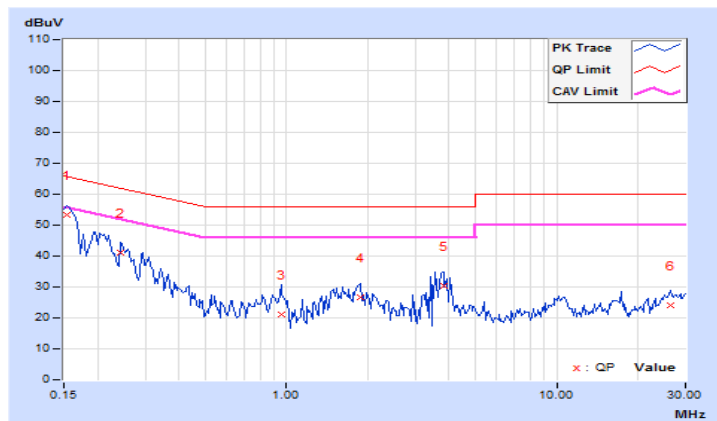

Phase	Neutral (N)	Detector Function	Quasi-Peak (QP) / Average (AV)
Test Mode	A		

No	Freq. [MHz]	Corr. Factor (dB)	Reading Value [dB (uV)]		Emission Level [dB (uV)]		Limit [dB (uV)]		Margin (dB)	
			Q.P.	AV.	Q.P.	AV.	Q.P.	AV.	Q.P.	AV.
			1	0.15391	9.68	44.17	28.54	53.85	38.22	65.79
2	0.17344	9.68	35.89	11.50	45.57	21.18	64.79	54.79	-19.22	-33.61
3	0.31016	9.67	28.54	15.51	38.21	25.18	59.97	49.97	-21.76	-24.79
4	1.94141	9.68	12.38	4.33	22.06	14.01	56.00	46.00	-33.94	-31.99
5	3.47266	9.72	20.07	9.50	29.79	19.22	56.00	46.00	-26.21	-26.78
6	3.71875	9.72	22.08	11.21	31.80	20.93	56.00	46.00	-24.20	-25.07

REMARKS:

1. Q.P. and AV. are abbreviations of quasi-peak and average individually.
2. The emission levels of other frequencies were very low against the limit.
3. Margin value = Emission level - Limit value
4. Correction factor = Insertion loss + Cable loss
5. Emission Level = Correction Factor + Reading Value.

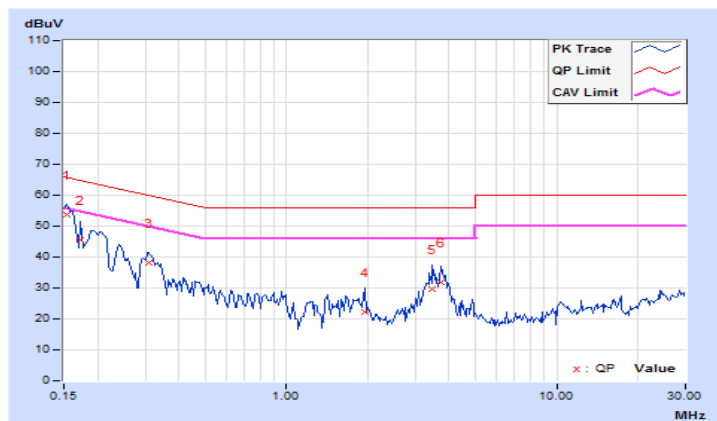

Phase	Line (L)	Detector Function	Quasi-Peak (QP) / Average (AV)
Test Mode	B		

No	Freq. [MHz]	Corr. Factor (dB)	Reading Value [dB (uV)]		Emission Level [dB (uV)]		Limit [dB (uV)]		Margin (dB)	
			Q.P.	AV.	Q.P.	AV.	Q.P.	AV.	Q.P.	AV.
			1	0.15781	9.73	35.78	21.51	45.51	31.24	65.58
2	0.18906	9.72	30.94	15.47	40.66	25.19	64.08	54.08	-23.42	-28.89
3	0.61875	9.72	34.49	25.50	44.21	35.22	56.00	46.00	-11.79	-10.78
4	1.03125	9.68	22.19	10.90	31.87	20.58	56.00	46.00	-24.13	-25.42
5	1.19922	9.69	20.59	10.08	30.28	19.77	56.00	46.00	-25.72	-26.23
6	11.25781	9.89	17.25	12.14	27.14	22.03	60.00	50.00	-32.86	-27.97

REMARKS:

1. Q.P. and AV. are abbreviations of quasi-peak and average individually.
2. The emission levels of other frequencies were very low against the limit.
3. Margin value = Emission level - Limit value
4. Correction factor = Insertion loss + Cable loss
5. Emission Level = Correction Factor + Reading Value.

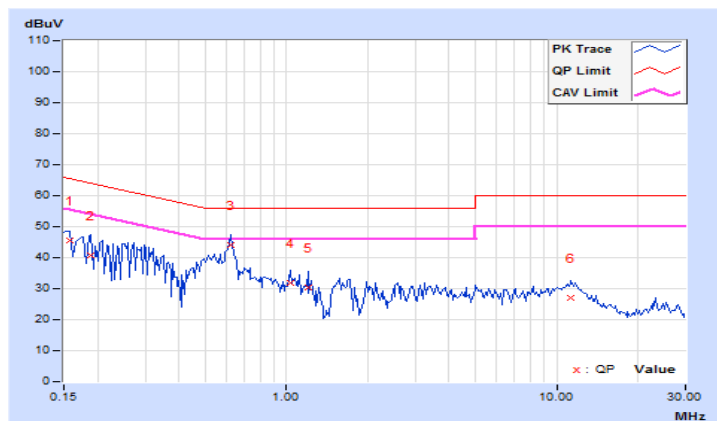

Phase	Neutral (N)	Detector Function	Quasi-Peak (QP) / Average (AV)
Test Mode	B		

No	Freq. [MHz]	Corr. Factor (dB)	Reading Value [dB (uV)]		Emission Level [dB (uV)]		Limit [dB (uV)]		Margin (dB)	
			Q.P.	AV.	Q.P.	AV.	Q.P.	AV.	Q.P.	AV.
			1	0.15391	9.72	33.72	19.11	43.44	28.83	65.79
2	0.61875	9.74	34.41	29.14	44.15	38.88	56.00	46.00	-11.85	-7.12
3	1.08594	9.72	22.20	14.57	31.92	24.29	56.00	46.00	-24.08	-21.71
4	1.68359	9.73	21.37	11.74	31.10	21.47	56.00	46.00	-24.90	-24.53
5	11.03906	9.93	15.11	2.51	25.04	12.44	60.00	50.00	-34.96	-37.56
6	25.00781	10.10	13.82	0.26	23.92	10.36	60.00	50.00	-36.08	-39.64

REMARKS:

1. Q.P. and AV. are abbreviations of quasi-peak and average individually.
2. The emission levels of other frequencies were very low against the limit.
3. Margin value = Emission level - Limit value
4. Correction factor = Insertion loss + Cable loss
5. Emission Level = Correction Factor + Reading Value.

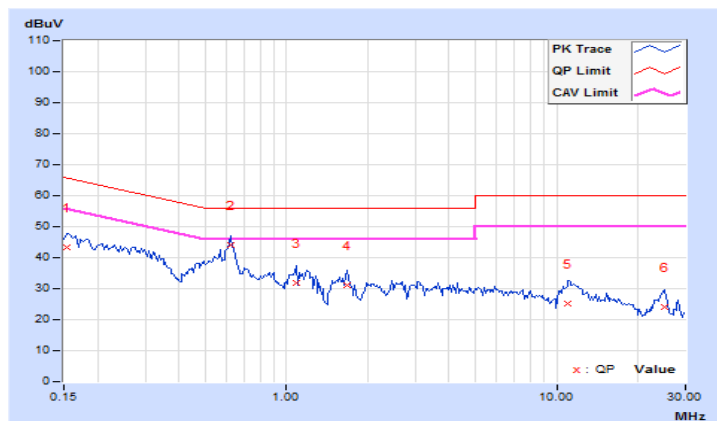

4.3 Transmit Power Measurement

4.3.1 Limits of Transmit Power Measurement

Operation Band	EUT Category		LIMIT
U-NII-1		Outdoor Access Point	1 Watt (30 dBm) (Max. e.i.r.p \leq 125mW(21 dBm) at any elevation angle above 30 degrees as measured from the horizon)
		Fixed point-to-point Access Point	1 Watt (30 dBm)
		Indoor Access Point	1 Watt (30 dBm)
	√	Mobile and Portable client device	250mW (24 dBm)
U-NII-2A		√	250mW (24 dBm) or 11 dBm+10 log B*
U-NII-2C		√	250mW (24 dBm) or 11 dBm+10 log B*
U-NII-3		√	1 Watt (30 dBm)

*B is the 26 dB emission bandwidth in megahertz

4.3.2 Test Setup

For Power Output
 802.11a, 802.11n (HT20), 802.11n (HT40)

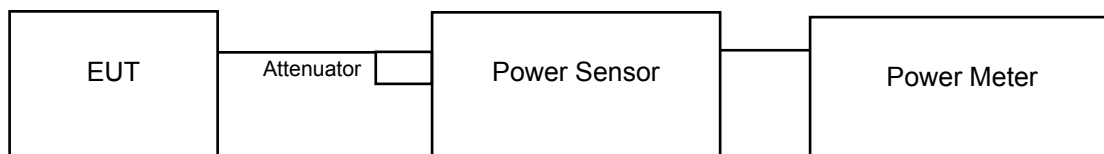

For 26dB and Occupied Bandwidth

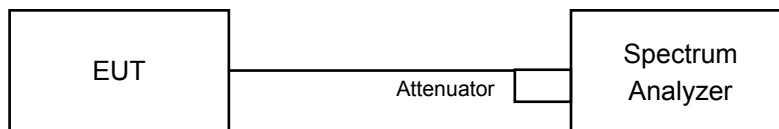

4.3.3 Test Instruments

Description & Manufacturer	Model No.	Serial No.	Cal. Date	Cal. Due
USB Wideband Power Meter (Including Power Sensor) KEYSIGHT	U2021XA	MY55050005/MY55190004/ MY55190007/MY55210005	Jul. 17, 2018	Jul. 16, 2019
SPECTRUM ANALYZER R&S	FSP40	100040	Sep. 25, 2018	Sep. 24, 2019

Note: 1. The calibration interval of the above test instruments is 12 months and the calibrations are traceable to NML/ROC and NIST/USA.

4.3.4 Test Procedure

For Average Power Measurement

For 802.11a, 802.11n (HT20), 802.11n (HT40)

Method PM is used to perform output power measurement, trigger and gating function of wide band power meter is enabled to measure max output power of TX on burst. Duty factor is not added to measured value.

For 26dB Bandwidth

- a. Set RBW = approximately 1% of the emission bandwidth.
- b. Set the VBW > RBW.
- c. Detector = Peak.
- d. Trace mode = max hold.
- e. Measure the maximum width of the emission that is 26 dB down from the peak of the emission. Compare this with the RBW setting of the analyzer. Readjust RBW and repeat measurement as needed until the RBW/EBW ratio is approximately 1%.

4.3.5 Deviation from Test Standard

No deviation.

4.3.6 EUT Operating Conditions

The software provided by client to enable the EUT under transmission condition continuously at lowest, middle and highest channel frequencies individually.

4.3.7 Test Result

Power Output:

802.11a

Chan.	Freq. (MHz)	Maximum Conducted Power (mW)	Maximum Conducted Power (dBm)	Power Limit (dBm)	Pass / Fail
36	5180	18.750	12.73	24	Pass
44	5220	19.634	12.93	24	Pass
48	5240	18.664	12.71	24	Pass
52	5260	19.724	12.95	24	Pass
60	5300	18.072	12.57	24	Pass
64	5320	17.219	12.36	24	Pass
100	5500	35.400	15.49	24	Pass
116	5580	56.624	17.53	24	Pass
140	5700	25.763	14.11	24	Pass
149	5745	23.768	13.76	30	Pass
157	5785	20.941	13.21	30	Pass
165	5825	25.763	14.11	30	Pass

Note:

For U-NII-2A, U-NII-2C Band:

1. $11\text{dBm} + 10\log(22.02) = 24.42 > 24\text{dBm}$
2. $11\text{dBm} + 10\log(22.18) = 24.45 > 24\text{dBm}$
3. $11\text{dBm} + 10\log(22.28) = 24.47 > 24\text{dBm}$
4. $11\text{dBm} + 10\log(28.07) = 25.48 > 24\text{dBm}$
5. $11\text{dBm} + 10\log(36.61) = 26.63 > 24\text{dBm}$
6. $11\text{dBm} + 10\log(23.82) = 24.76 > 24\text{dBm}$

802.11n (HT20)

Chan.	Freq. (MHz)	Maximum Conducted Power (mW)	Maximum Conducted Power (dBm)	Power Limit (dBm)	Pass / Fail
36	5180	18.281	12.62	24	Pass
44	5220	20.184	13.05	24	Pass
48	5240	20.606	13.14	24	Pass
52	5260	18.239	12.61	24	Pass
60	5300	20.749	13.17	24	Pass
64	5320	16.672	12.22	24	Pass
100	5500	22.856	13.59	24	Pass
116	5580	28.774	14.59	24	Pass
140	5700	28.249	14.51	24	Pass
149	5745	29.174	14.65	30	Pass
157	5785	26.002	14.15	30	Pass
165	5825	21.577	13.34	30	Pass

Note:

For U-NII-2A, U-NII-2C Band:

1. $11\text{dBm} + 10\log(23.16) = 24.64 > 24\text{dBm}$
2. $11\text{dBm} + 10\log(23.81) = 24.76 > 24\text{dBm}$
3. $11\text{dBm} + 10\log(22.86) = 24.59 > 24\text{dBm}$
4. $11\text{dBm} + 10\log(24.85) = 24.95 > 24\text{dBm}$
5. $11\text{dBm} + 10\log(26.67) = 25.26 > 24\text{dBm}$
6. $11\text{dBm} + 10\log(23.19) = 24.65 > 24\text{dBm}$

802.11n (HT40)

Chan.	Freq. (MHz)	Maximum Conducted Power (mW)	Maximum Conducted Power (dBm)	Power Limit (dBm)	Pass / Fail
38	5190	19.953	13.00	24	Pass
46	5230	19.999	13.01	24	Pass
54	5270	25.763	14.11	24	Pass
62	5310	19.770	12.96	24	Pass
102	5510	25.882	14.13	24	Pass
110	5550	31.405	14.97	24	Pass
134	5670	32.211	15.08	24	Pass
151	5755	32.285	15.09	30	Pass
159	5795	25.003	13.98	30	Pass

Note:

For U-NII-2A, U-NII-2C Band:

1. $11\text{dBm} + 10\log(50.31) = 28.01 > 24\text{dBm}$
2. $11\text{dBm} + 10\log(50.36) = 28.02 > 24\text{dBm}$
3. $11\text{dBm} + 10\log(56.27) = 28.50 > 24\text{dBm}$
4. $11\text{dBm} + 10\log(63.15) = 29.00 > 24\text{dBm}$
5. $11\text{dBm} + 10\log(58.34) = 28.65 > 24\text{dBm}$

26dB Bandwidth:

802.11a

Chan.	Freq. (MHz)	26dBc Bandwidth (MHz)
36	5180	21.44
44	5220	22.26
48	5240	21.75
52	5260	22.02
60	5300	22.18
64	5320	22.28
100	5500	28.07
116	5580	36.61
140	5700	23.82

802.11n (HT20)

Chan.	Freq. (MHz)	26dBc Bandwidth (MHz)
36	5180	22.71
44	5220	22.86
48	5240	23.17
52	5260	23.16
60	5300	23.81
64	5320	22.86
100	5500	24.85
116	5580	26.67
140	5700	23.19

802.11n (HT40)

Chan.	Freq. (MHz)	26dBc Bandwidth (MHz)
38	5190	45.72
46	5230	49.44
54	5270	50.31
62	5310	50.36
102	5510	56.27
110	5550	63.15
134	5670	58.34

Spectrum Plot of Worst Value

802.11a

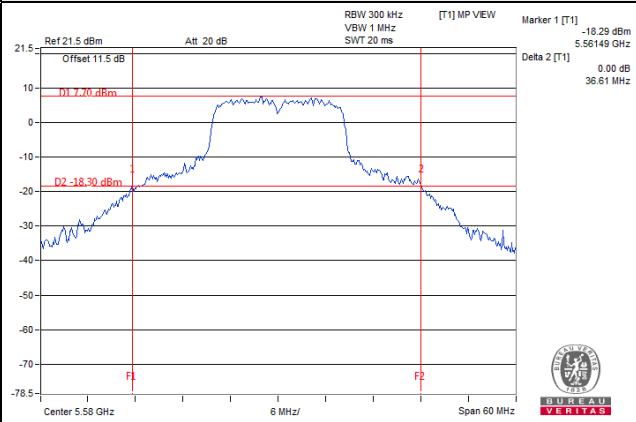

802.11n (HT20)

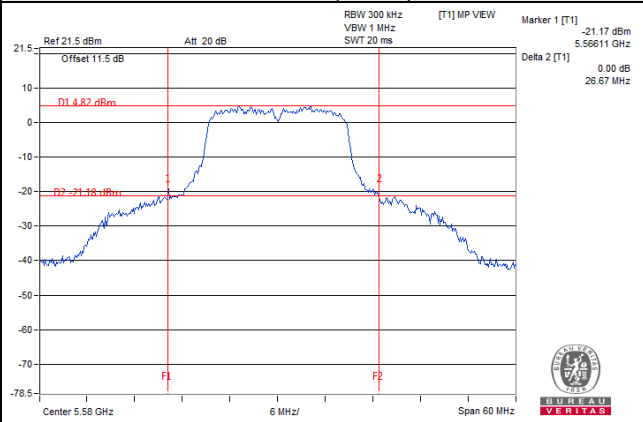

802.11n (HT40)

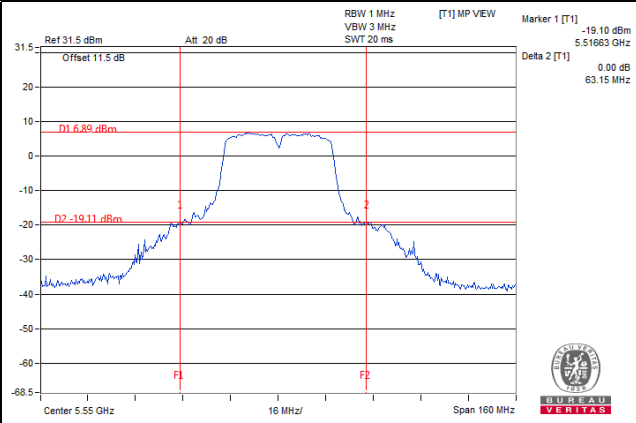

EUT Maximum Conducted Power

802.11a

Frequency Band (MHz)	Max. Power	
	Output Power (mW)	Output Power (dBm)
5250~5350	19.724	12.95
5470~5725	56.624	17.53

802.11n (HT20)

Frequency Band (MHz)	Max. Power	
	Output Power (mW)	Output Power (dBm)
5250~5350	20.749	13.17
5470~5725	28.774	14.59

802.11n (HT40)

Frequency Band (MHz)	Max. Power	
	Output Power (mW)	Output Power (dBm)
5250~5350	25.763	14.11
5470~5725	32.211	15.08

4.4 Occupied Bandwidth Measurement

4.4.1 Test Setup

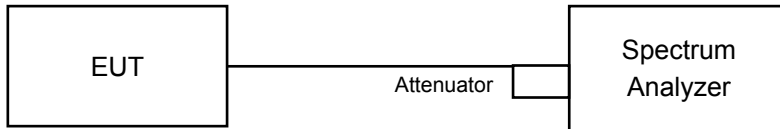

4.4.2 Test Instruments

Description & Manufacturer	Model No.	Serial No.	Cal. Date	Cal. Due
SPECTRUM ANALYZER R&S	FSP40	100040	Sep. 25, 2018	Sep. 24, 2019

Note: 1. The calibration interval of the above test instruments is 12 months and the calibrations are traceable to NML/ROC and NIST/USA.

4.4.3 Test Procedure

The transmitter output was connected to the spectrum analyzer through an attenuator. The bandwidth of the fundamental frequency was measured by spectrum analyzer with resolution bandwidth in the range of 1% to 5% of the anticipated emission bandwidth, and a video bandwidth at least 3x the resolution bandwidth and set the detector to sampling. The width of a frequency band such that, below the lower and above the upper frequency limits, the mean powers emitted are each equal to a specified percentage 0.5 %of the total mean power of a given emission.

4.4.4 Test Result

802.11a

Channel	Frequency (MHz)	Occupied Bandwidth (MHz)
36	5180	16.68
44	5220	16.68
48	5240	16.68
52	5260	16.68
60	5300	16.68
64	5320	16.80
100	5500	17.04
116	5580	18.84
140	5700	16.80
149	5745	16.80
157	5785	16.68
165	5825	16.68

802.11n (HT20)

Channel	Frequency (MHz)	Occupied Bandwidth (MHz)
36	5180	17.76
44	5220	17.76
48	5240	17.76
52	5260	17.76
60	5300	17.88
64	5320	17.88
100	5500	17.88
116	5580	18.00
140	5700	17.88
149	5745	17.88
157	5785	17.76
165	5825	17.76

802.11n (HT40)

Channel	Frequency (MHz)	Occupied Bandwidth (MHz)
38	5190	36.24
46	5230	37.20
54	5270	37.08
62	5310	37.20
102	5510	37.32
110	5550	37.20
134	5670	37.32
151	5755	37.32
159	5795	37.32

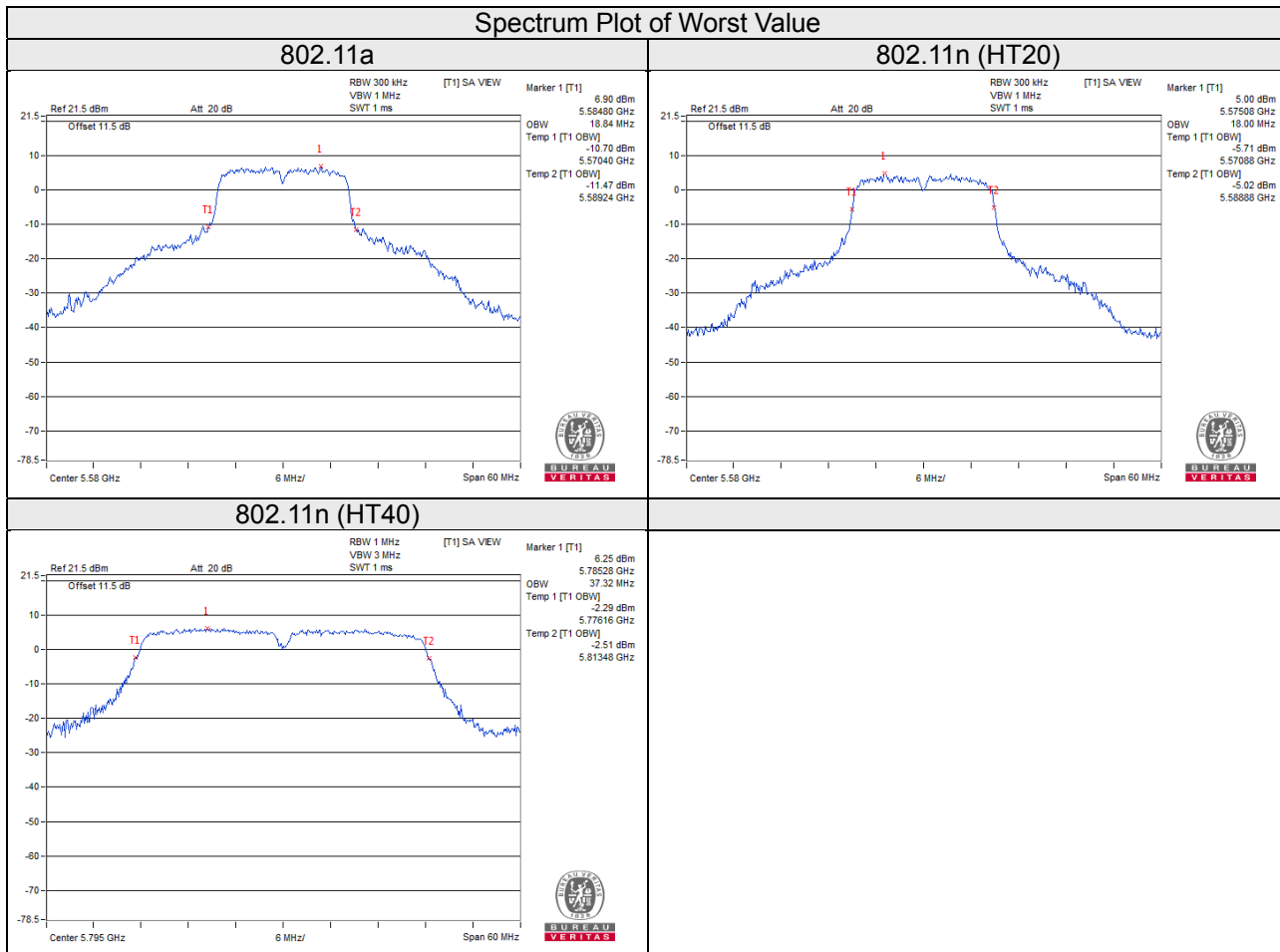

4.5 Peak Power Spectral Density Measurement

4.5.1 Limits of Peak Power Spectral Density Measurement

Operation Band	EUT Category		LIMIT
U-NII-1		Outdoor Access Point	17dBm/ MHz
		Fixed point-to-point Access Point	
		Indoor Access Point	
	√	Mobile and Portable client device	11dBm/ MHz
U-NII-2A		√	11dBm/ MHz
U-NII-2C		√	11dBm/ MHz
U-NII-3		√	30dBm/ 500kHz

4.5.2 Test Setup

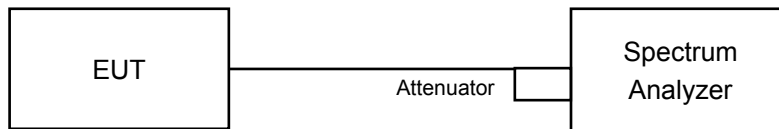

4.5.3 Test Instruments

Description & Manufacturer	Model No.	Serial No.	Cal. Date	Cal. Due
SPECTRUM ANALYZER R&S	FSP40	100040	Sep. 25, 2018	Sep. 24, 2019

Note: 1. The calibration interval of the above test instruments is 12 months and the calibrations are traceable to NML/ROC and NIST/USA.

4.5.4 Test Procedures

For U-NII-1, U-NII-2A, U-NII-2C band:

Duty cycle of test signal is $\geq 98\%$

Using method SA-1

- 1) Set span to encompass the entire emission bandwidth (EBW) of the signal.
- 2) Set RBW = 1MHz, Set VBW ≥ 3 MHz, Detector = RMS
- 3) Set Channel power measure = 1MHz
- 4) Sweep time = auto, trigger set to "free run".
- 5) Trace average at least 100 traces in power averaging mode.
- 6) Record the max value

Duty cycle of test signal is $< 98\%$

Using method SA-2

- 1) Set span to encompass the entire emission bandwidth (EBW) of the signal.
- 2) Set RBW = 1MHz, Set VBW ≥ 3 MHz, Detector = RMS
- 3) Set Channel power measure = 1MHz
- 4) Sweep time = auto, trigger set to "free run".
- 5) Trace average at least 100 traces in power averaging mode.
- 6) Record the max value and add $10 \log (1/\text{duty cycle})$

For U-NII-3 band:

Duty cycle of test signal is $\geq 98\%$

Using method SA-1

- 1) Set span to encompass the entire emission bandwidth (EBW) of the signal.
- 2) Set RBW = 300 kHz, Set VBW ≥ 1 MHz, Detector = RMS.
- 3) Use the peak marker function to determine the maximum power level in any 300 kHz band segment within the fundamental EBW.
- 4) Scale the observed power level to an equivalent value in 500 kHz by adjusting (reducing) the measured power by a bandwidth correction factor (BWCF) where $BWCF = 10\log(500 \text{ kHz} / 300 \text{ kHz})$.
- 5) Sweep time = auto, trigger set to "free run".
- 6) Trace average at least 100 traces in power averaging mode.
- 7) Record the max value.

Duty cycle of test signal is $< 98\%$

- 1) Set span to encompass the entire emission bandwidth (EBW) of the signal.
- 2) Set RBW = 300 kHz, Set VBW ≥ 1 MHz, Detector = RMS
- 3) Use the peak marker function to determine the maximum power level in any 300 kHz band segment within the fundamental EBW.
- 4) Scale the observed power level to an equivalent value in 500 kHz by adjusting (reducing) the measured power by a bandwidth correction factor (BWCF) where $BWCF = 10\log(500 \text{ kHz} / 300 \text{ kHz})$
- 5) Sweep time = auto, trigger set to "free run".
- 6) Trace average at least 100 traces in power averaging mode.
- 7) Record the max value and add $10 \log (1/\text{duty cycle})$

4.5.5 Deviation from Test Standard

No deviation.

4.5.6 EUT Operating Conditions

Same as 4.3.6.

4.5.7 Test Results

For U-NII-1, U-NII-2A, U-NII-2C band

802.11a

Chan.	Freq. (MHz)	PSD (dBm/MHz)	MAX. Limit (dBm/MHz)	Pass / Fail
36	5180	-1.31	11	Pass
44	5220	-1.09	11	Pass
48	5240	-1.45	11	Pass
52	5260	-1.10	11	Pass
60	5300	-1.44	11	Pass
64	5320	-1.57	11	Pass
100	5500	0.87	11	Pass
116	5580	2.78	11	Pass
140	5700	0.63	11	Pass

802.11n (HT20)

Chan.	Freq. (MHz)	PSD w/o Duty Factor (dBm/MHz)	Duty Factor (dB)	PSD With Duty Factor (dBm/MHz)	MAX. Limit (dBm/MHz)	Pass / Fail
36	5180	-2.19	0.09	-2.10	11	Pass
44	5220	-1.96	0.09	-1.87	11	Pass
48	5240	-1.50	0.09	-1.41	11	Pass
52	5260	-1.33	0.09	-1.24	11	Pass
60	5300	-1.68	0.09	-1.59	11	Pass
64	5320	-1.79	0.09	-1.70	11	Pass
100	5500	-0.54	0.09	-0.45	11	Pass
116	5580	0.23	0.09	0.32	11	Pass
140	5700	-0.13	0.09	-0.04	11	Pass

Note: Refer to section 3.3 for duty cycle spectrum plot.

802.11n (HT40)

Chan.	Freq. (MHz)	PSD w/o Duty Factor (dBm/MHz)	Duty Factor (dB)	PSD With Duty Factor (dBm/MHz)	MAX. Limit (dBm/MHz)	Pass / Fail
38	5190	-5.17	0.19	-4.98	11	Pass
46	5230	-4.62	0.19	-4.43	11	Pass
54	5270	-4.03	0.19	-3.84	11	Pass
62	5310	-4.05	0.19	-3.86	11	Pass
102	5510	-3.63	0.19	-3.44	11	Pass
110	5550	-3.00	0.19	-2.81	11	Pass
134	5670	-2.66	0.19	-2.47	11	Pass

Note: Refer to section 3.3 for duty cycle spectrum plot.

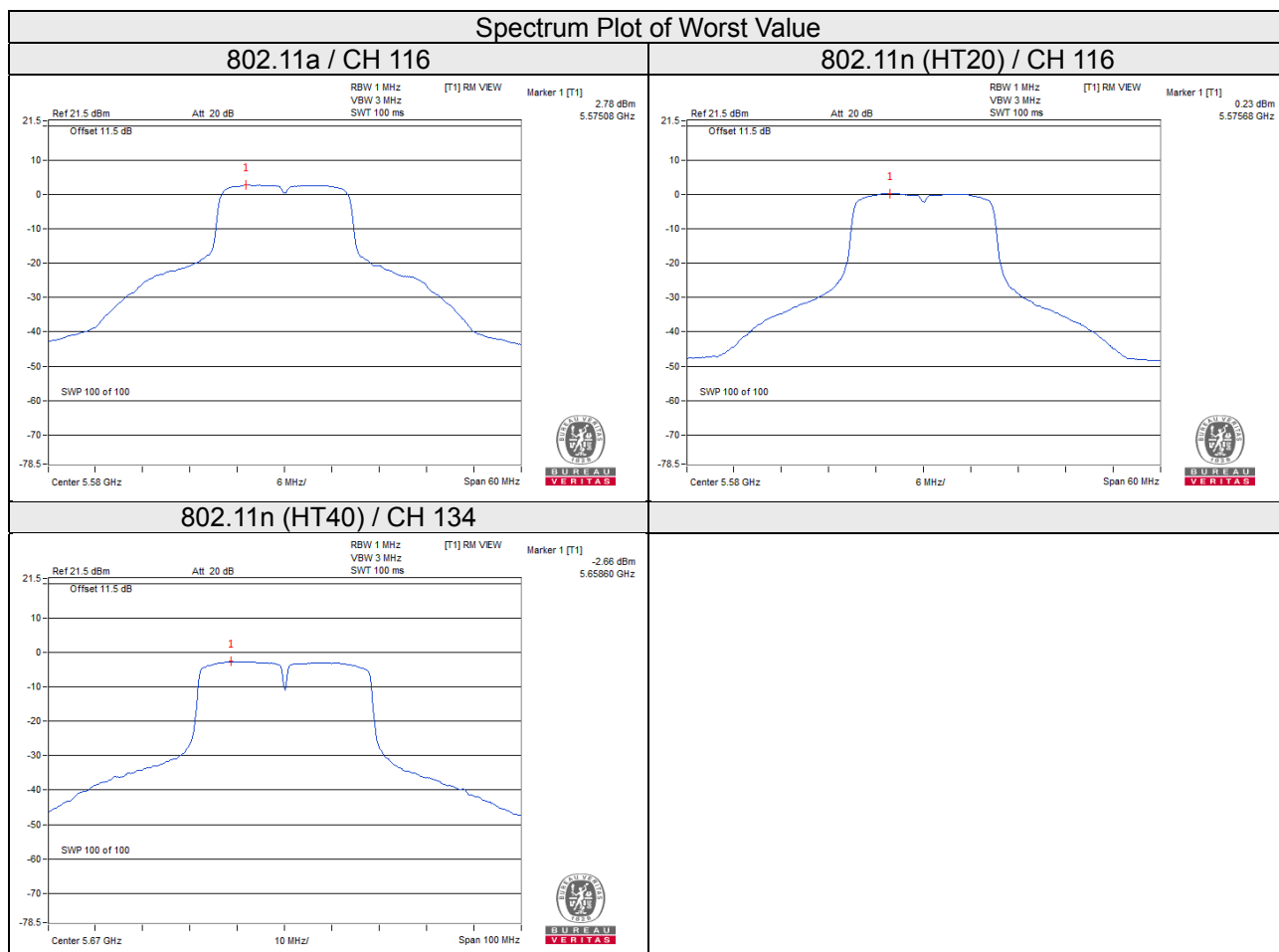

For U-NII-3 band:

802.11a

Chan.	Freq. (MHz)	PSD		Limit (dBm/500kHz)	Pass / Fail
		(dBm/300kHz)	(dBm/500kHz)		
149	5745	-8.19	-5.97	30	Pass
157	5785	-8.69	-6.47	30	Pass
165	5825	-8.76	-6.54	30	Pass

802.11n (HT20)

Chan.	Freq. (MHz)	PSD w/o Duty Factor		Duty Factor (dB)	PSD with Duty Factor (dBm/500kHz)	Limit (dBm/500kHz)	Pass / Fail
		(dBm/300kHz)	(dBm/500kHz)				
149	5745	-7.93	-5.71	0.09	-5.62	30	Pass
157	5785	-8.84	-6.62	0.09	-6.53	30	Pass
165	5825	-9.18	-6.96	0.09	-6.87	30	Pass

Note: Refer to section 3.1 for duty cycle spectrum plot.

802.11n (HT40)

Chan.	Freq. (MHz)	PSD w/o Duty Factor		Duty Factor (dB)	PSD with Duty Factor (dBm/500kHz)	Limit (dBm/500kHz)	Pass / Fail
		(dBm/300kHz)	(dBm/500kHz)				
151	5755	-11.34	-9.12	0.19	-8.93	30	Pass
159	5795	-12.24	-10.02	0.19	-9.83	30	Pass

Note: Refer to section 3.1 for duty cycle spectrum plot.

Spectrum Plot of Worst Value

802.11a

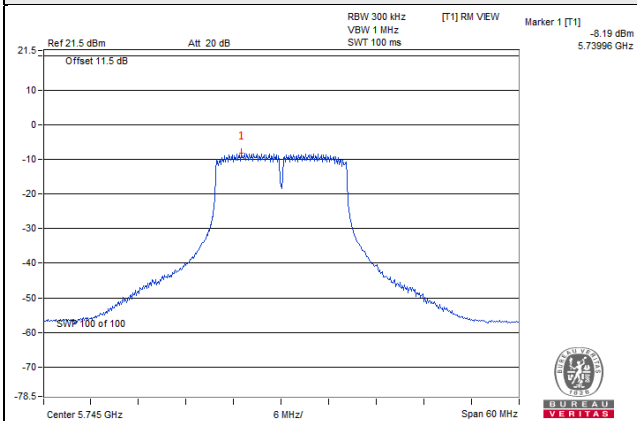

802.11n (HT20)

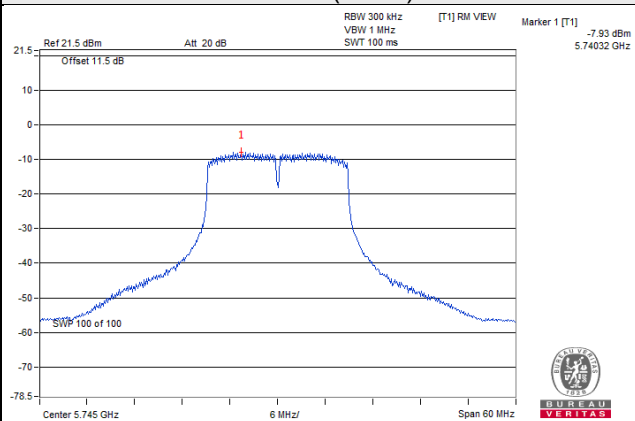

802.11n (HT40)

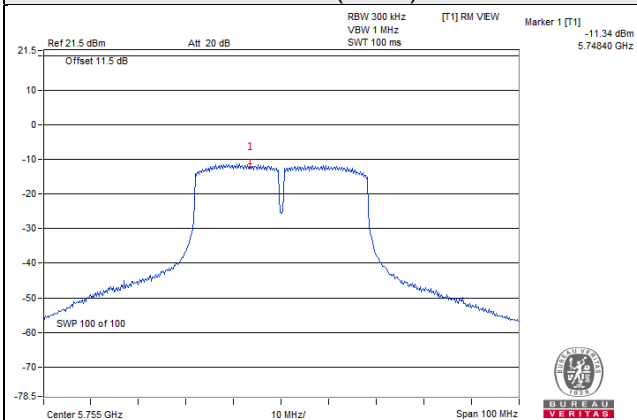

4.6 Frequency Stability

4.6.1 Limits of Frequency Stability Measurement

The frequency of the carrier signal shall be maintained within band of operation

4.6.2 Test Setup

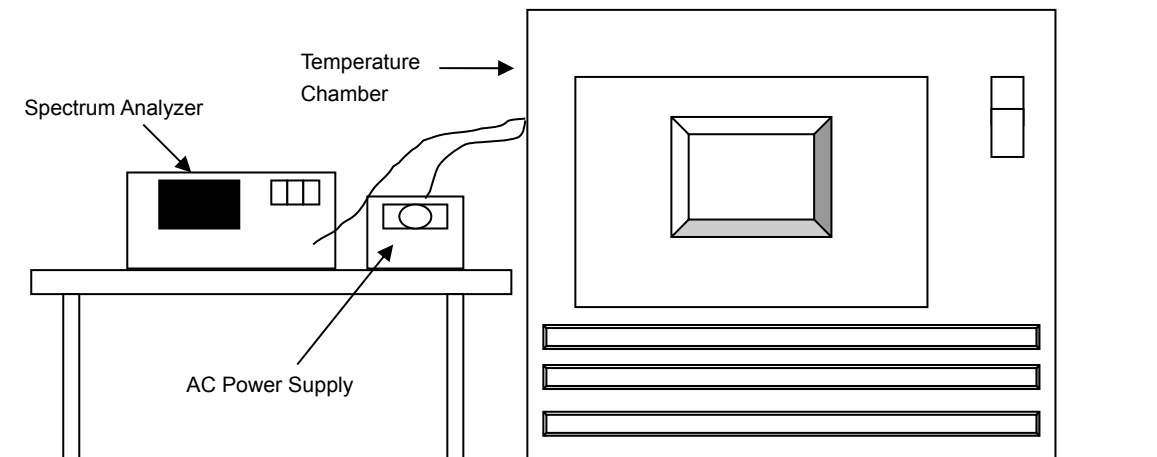

4.6.3 Test Instruments

Description & Manufacturer	Model No.	Serial No.	Cal. Date	Cal. Due
Spectrum Analyzer ROHDE & SCHWARZ	FSP40	100040	Sep. 25, 2018	Sep. 24, 2019
WIT Standard Temperature And Humidity Chamber	TH-4S-C	W981030	Jun. 04, 2018	Jun. 03, 2019
Digital Multimeter Fluke	87-III	70360742	Jun. 29, 2018	Jun. 28, 2019
AC Power Supply Exttech	CFW-105	E000603	NA	NA

Note: 1. The calibration interval of the above test instruments is 12 months and the calibrations are traceable to NML/ROC and NIST/USA.

4.6.4 Test Procedure

- The EUT was placed inside the environmental test chamber and powered by nominal AC voltage.
- Turn the EUT on and couple its output to a spectrum analyzer.
- Turn the EUT off and set the chamber to the highest temperature specified.
- Allow sufficient time (approximately 30 min) for the temperature of the chamber to stabilize, turn the EUT on and measure the operating frequency after 2, 5, and 10 minutes.
- Repeat step 2 and 3 with the temperature chamber set to the lowest temperature.
- The test chamber was allowed to stabilize at +20 degree C for a minimum of 30 minutes. The supply voltage was then adjusted on the EUT from 85% to 115% and the frequency record.

4.6.5 Deviation from Test Standard

No deviation.

4.6.6 EUT Operating Condition

Set the EUT transmit at un-modulation mode to test frequency stability.

4.6.7 Test Results

Frequency Stability Versus Temp.									
Operating Frequency: 5180MHz									
Temp. (°C)	Power Supply (Vac)	0 Minute		2 Minute		5 Minute		10 Minute	
		Measured Frequency (MHz)	Result	Measured Frequency (MHz)	Result	Measured Frequency (MHz)	Result	Measured Frequency (MHz)	Result
50	120	5179.9864	PASS	5179.9860	PASS	5179.9876	PASS	5179.9858	PASS
40	120	5180.0020	PASS	5180.0025	PASS	5180.0047	PASS	5180.0019	PASS
30	120	5180.0268	PASS	5180.0261	PASS	5180.0280	PASS	5180.0239	PASS
20	120	5179.9762	PASS	5179.9781	PASS	5179.9744	PASS	5179.9766	PASS
10	120	5179.9802	PASS	5179.9782	PASS	5179.9769	PASS	5179.9804	PASS
0	120	5180.0254	PASS	5180.0236	PASS	5180.0244	PASS	5180.0249	PASS
-10	120	5180.0097	PASS	5180.0100	PASS	5180.0108	PASS	5180.0087	PASS
-20	120	5179.9748	PASS	5179.9766	PASS	5179.9769	PASS	5179.9774	PASS
-30	120	5179.9942	PASS	5179.9968	PASS	5179.9969	PASS	5179.9967	PASS

Frequency Stability Versus Voltage									
Operating Frequency: 5180MHz									
Temp. (°C)	Power Supply (Vac)	0 Minute		2 Minute		5 Minute		10 Minute	
		Measured Frequency (MHz)	Result	Measured Frequency (MHz)	Result	Measured Frequency (MHz)	Result	Measured Frequency (MHz)	Result
20	138	5179.9762	PASS	5179.9777	PASS	5179.9744	PASS	5179.9768	PASS
	120	5179.9762	PASS	5179.9781	PASS	5179.9744	PASS	5179.9766	PASS
	102	5179.9753	PASS	5179.9784	PASS	5179.9743	PASS	5179.9769	PASS

4.7 6dB Bandwidth Measurement

4.7.1 Limits of 6dB Bandwidth Measurement

The minimum of 6dB Bandwidth Measurement is 0.5MHz.

4.7.2 Test Setup

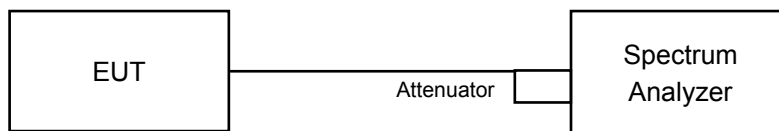

4.7.3 Test Instruments

Description & Manufacturer	Model No.	Serial No.	Cal. Date	Cal. Due
SPECTRUM ANALYZER R&S	FSP40	100040	Sep. 25, 2018	Sep. 24, 2019

Note: 1. The calibration interval of the above test instruments is 12 months and the calibrations are traceable to NML/ROC and NIST/USA.

4.7.4 Test Procedure

Measurement Procedure REF

- Set resolution bandwidth (RBW) = 100kHz
- Set the video bandwidth (VBW) $\geq 3 \times$ RBW, Detector = Peak.
- Trace mode = max hold.
- Sweep = auto couple.
- Measure the maximum width of the emission that is constrained by the frequencies associated with the two amplitude points (upper and lower) that are attenuated by 6 dB relative to the maximum level measured in the fundamental emission

4.7.5 Deviation from Test Standard

No deviation.

4.7.6 EUT Operating Condition

The software provided by client to enable the EUT under transmission condition continuously at lowest, middle and highest channel frequencies individually.

4.7.7 Test Results

802.11a

Channel	Frequency (MHz)	6dB Bandwidth (MHz)	Minimum Limit (MHz)	Pass / Fail
149	5745	16.09	0.5	Pass
157	5785	16.32	0.5	Pass
165	5825	16.08	0.5	Pass

802.11n (HT20)

Channel	Frequency (MHz)	6dB Bandwidth (MHz)	Minimum Limit (MHz)	Pass / Fail
149	5745	16.88	0.5	Pass
157	5785	16.87	0.5	Pass
165	5825	16.87	0.5	Pass

802.11n (HT40)

Channel	Frequency (MHz)	6dB Bandwidth (MHz)	Minimum Limit (MHz)	Pass / Fail
151	5755	35.51	0.5	Pass
159	5795	35.54	0.5	Pass

Spectrum Plot of Worst Value

802.11a

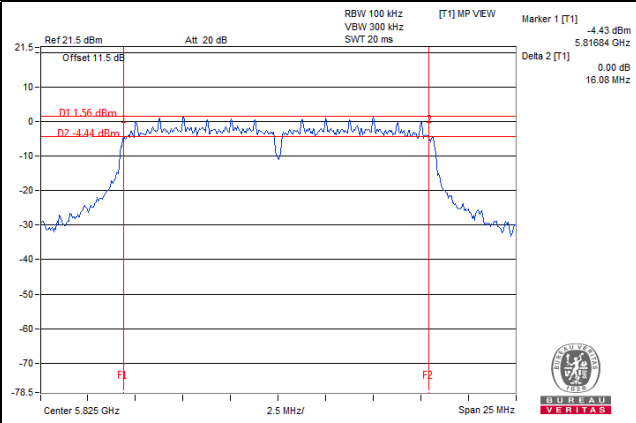

802.11n (HT20)

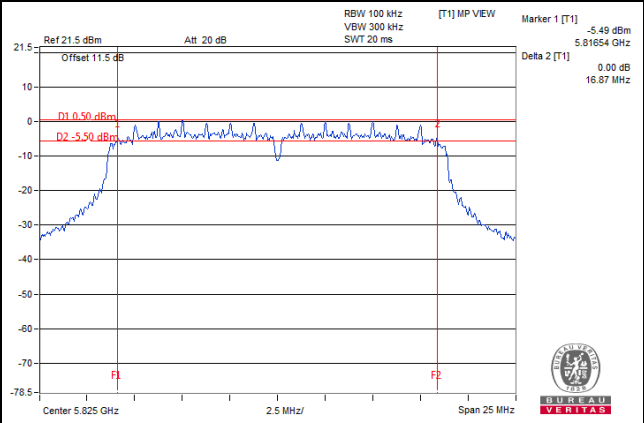

802.11n (HT40)

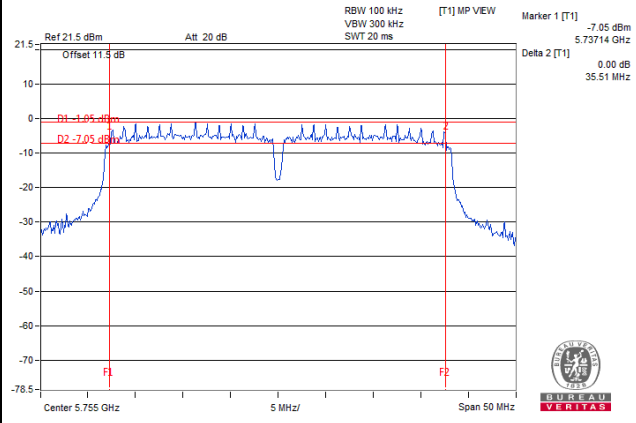

5 Pictures of Test Arrangements

Please refer to the attached file (Test Setup Photo).

Appendix – Information of the Testing Laboratories

We, Bureau Veritas Consumer Products Services (H.K.) Ltd., Taoyuan Branch, were founded in 1988 to provide our best service in EMC, Radio, Telecom and Safety consultation. Our laboratories are accredited and approved according to ISO/IEC 17025.

If you have any comments, please feel free to contact us at the following:

Lin Kou EMC/RF Lab

Tel: 886-2-26052180

Fax: 886-2-26051924

Hsin Chu EMC/RF/Telecom Lab

Tel: 886-3-6668565

Fax: 886-3-6668323

Hwa Ya EMC/RF/Safety

Tel: 886-3-3183232

Fax: 886-3-3270892

Email: service.adt@tw.bureauveritas.com

Web Site: www.bureauveritas-adt.com

The address and road map of all our labs can be found in our web site also.

--- END ---