

FCC Test Report

(Co-Located)

Report No.: RF170103C26-9

FCC ID: ZQAH10

Test Model: A0024

Received Date: Jan. 03, 2017

Test Date: Jul. 20, 2017

Issued Date: Jul. 24, 2017

Applicant: Nest Labs Inc.

Address: 3400 Hillview Ave. Palo Alto California, United States 94304

Issued By: Bureau Veritas Consumer Products Services (H.K.) Ltd., Taoyuan Branch

Lab Address: No. 47-2, 14th Ling, Chia Pau Vil., Lin Kou Dist., New Taipei City, Taiwan
(R.O.C)

Test Location: No.19, Hwa Ya 2nd Rd., Wen Hwa Vil., Kwei Shan Dist., Taoyuan City
33383, Taiwan, R.O.C.



This report is for your exclusive use. Any copying or replication of this report to or for any other person or entity, or use of our name or trademark, is permitted only with our prior written permission. This report sets forth our findings solely with respect to the test samples identified herein. The results set forth in this report are not indicative or representative of the quality or characteristics of the lot from which a test sample was taken or any similar or identical product unless specifically and expressly noted. Our report includes all of the tests requested by you and the results thereof based upon the information that you provided to us. You have 60 days from date of issuance of this report to notify us of any material error or omission caused by our negligence, provided, however, that such notice shall be in writing and shall specifically address the issue you wish to raise. A failure to raise such issue within the prescribed time shall constitute your unqualified acceptance of the completeness of this report, the tests conducted and the correctness of the report contents. Unless specific mention, the uncertainty of measurement has been explicitly taken into account to declare the compliance or non-compliance to the specification.

Table of Contents

Release Control Record	3
1 Certificate of Conformity	4
2 Summary of Test Results.....	5
2.1 Measurement Uncertainty.....	5
2.2 Modification Record	5
3 General Information	6
3.1 General Description of EUT	6
3.2 Description of Test Modes.....	8
3.2.1 Test Mode Applicability and Tested Channel Detail.....	10
3.3 Description of Support Units	11
3.3.1 Configuration of System under Test	11
3.4 General Description of Applied Standards.....	11
4 Test Types and Results	12
4.1 Radiated Emission and Bandedge Measurement	12
4.1.1 Limits of Radiated Emission and Bandedge Measurement	12
4.1.2 Test Instruments	14
4.1.3 Test Procedures.....	15
4.1.4 Deviation from Test Standard	15
4.1.5 Test Set Up	16
4.1.6 EUT Operating Conditions.....	16
4.1.7 Test Results	17
5 Pictures of Test Arrangements.....	31
Appendix – Information on the Testing Laboratories	32

Release Control Record

Issue No.	Description	Date Issued
RF170103C26-9	Original Release	Jul. 24, 2017

1 Certificate of Conformity

Product: Home security device

Brand: Nest Guard

Test Model: A0024

Sample Status: Identical Prototype

Applicant: Nest Labs Inc.

Test Date: Jul. 20, 2017

Standards: 47 CFR FCC Part 15, Subpart C (Section 15.247)
47 CFR FCC Part 15, Subpart E (Section 15.407)
47 CFR FCC Part 15, Subpart C (Section 15.225)
47 CFR FCC Part 15, Subpart C (Section 15.215)
FCC Part 22, Subpart H
FCC Part 24, Subpart E
FCC Part 27, Subpart C, L
ANSI C63.10:2013

The above equipment has been tested by **Bureau Veritas Consumer Products Services (H.K.) Ltd., Taoyuan Branch**, and found compliance with the requirement of the above standards. The test record, data evaluation & Equipment Under Test (EUT) configurations represented herein are true and accurate accounts of the measurements of the sample's EMC characteristics under the conditions specified in this report.

Prepared by :

Rona Chen

Date:

Jul. 24, 2017

Rona Chen / Specialist

Approved by :

David Huang

Date:

Jul. 24, 2017

David Huang / Project Engineer

2 Summary of Test Results

Applied Standard	47 CFR FCC Part 15, Subpart C (Section 15.247) 47 CFR FCC Part 15, Subpart E (Section 15.407) 47 CFR FCC Part 15, Subpart C (Section 15.225, 15.215) FCC Part 22 & Part 2 FCC Part 24 & Part 2 FCC Part 27 & Part 2 (LTE 4 / LTE 12)		
FCC Clause	Test Item	Result	Remarks
15.205 / 15.209 / 15.247(d)	Radiated Emissions	Pass	Meet the requirement of limit. Minimum passing margin is -6.04 dB at 40.68 MHz.
15.407(b) (1/2/3/4(i/ii)/6)			
15.225 (a)			
2.1053 / 22.917			
2.1053 / 24.238			
2.1053 / 27.53(h)			
2.1053 / 27.53(g)			

2.1 Measurement Uncertainty

Where relevant, the following measurement uncertainty levels have been estimated for tests performed on the EUT:

The listed uncertainties are the worst case uncertainty for the entire range of measurement. Please note that the uncertainty values are provided for informational purposes only and are not used in determining the PASS/FAIL results.

Measurement	Frequency	Expanded Uncertainty (k=2) (±)
Radiated Emissions up to 1 GHz	30 MHz ~ 200 MHz	2.93 dB
	200 MHz ~1000 MHz	2.95 dB
Radiated Emissions above 1 GHz	1 GHz ~ 18 GHz	2.26 dB
	18 GHz ~ 40 GHz	1.94 dB

2.2 Modification Record

There were no modifications required for compliance.

3 General Information

3.1 General Description of EUT

Product	Home security device
Brand	Nest Guard
Test Model	A0024
Status of EUT	Identical Prototype
Power Supply Rating	5.0 Vdc (adapter or host equipment) 3.7 Vdc (Li-ion battery)
Antenna Connector	N/A
Accessory Device	Refer to Note as below
Data Cable Supplied	Refer to Note as below

Note:

1. The EUT provides 1 completed transmitter and 1 receiver.

WLAN / Bluetooth LE / 802.15.4 Specification		
Modulation Type	WLAN	CCK, DQPSK, DBPSK for DSSS 64QAM, 16QAM, QPSK, BPSK for OFDM
	Bluetooth LE	GFSK
	802.15.4	O-QPSK
Modulation Technology	WLAN	DSSS, OFDM
	802.15.4	DSSS
Transfer Rate	WLAN	802.11b: 11.0 / 5.5 / 2.0 / 1.0 Mbps 802.11g: 54.0 / 48.0 / 36.0 / 24.0 / 18.0 / 12.0 / 9.0 / 6.0 Mbps 802.11a: 54.0 / 48.0 / 36.0 / 24.0 / 18.0 / 12.0 / 9.0 / 6.0 Mbps 802.11n: up to MCS7
	Bluetooth LE	1 Mbps
	802.15.4	250 kbps
Operating Frequency	WLAN	2.4GHz: 2412 ~ 2462 MHz 5GHz: 5180 ~ 5240 MHz, 5260 ~ 5320 MHz, 5500 ~ 5700 MHz, 5745 ~ 5825 MHz
	Bluetooth LE	2402 ~ 2480 MHz
	802.15.4	2405 ~ 2475 MHz
Number of Channel	WLAN	2.4GHz: 11 for 802.11b, 802.11g, 802.11n (HT20) 5GHz: 5180 ~ 5240 MHz: 4 for 802.11a, 802.11n (HT20) 5260 ~ 5320 MHz: 4 for 802.11a, 802.11n (HT20) 5500 ~ 5700 MHz: 11 for 802.11a, 802.11n (HT20) 5745 ~ 5825 MHz: 5 for 802.11a, 802.11n (HT20)
	Bluetooth LE	40
	802.15.4	15
Antenna Type	WLAN	2.4GHz: Monopole Type antenna with 2.95 dBi gain 5GHz: Monopole Type antenna with 3.06 dBi gain (5180 ~ 5240 MHz) Monopole Type antenna with 3.21 dBi gain (5260 ~ 5320 MHz) Monopole Type antenna with 1.90 dBi gain (5500 ~ 5700 MHz) Monopole Type antenna with 2.56 dBi gain (5745 ~ 5825 MHz)
	Bluetooth LE	Monopole Type antenna with 0.73 dBi gain
	802.15.4	Monopole Type antenna with 1.54 dBi gain

WWAN Specification		
Modulation Type	WCDMA	BPSK
	LTE	QPSK, 16QAM
Frequency Range	WCDMA II	1852.4 ~ 1907.6 MHz
	WCDMA V	826.4 ~ 846.6 MHz
	LTE Band 2 (Channel Bandwidth: 1.4 MHz)	1850.7 ~ 1909.3 MHz
	LTE Band 2 (Channel Bandwidth: 3 MHz)	1851.5 ~ 1908.5 MHz
	LTE Band 2 (Channel Bandwidth: 5 MHz)	1852.5 ~ 1907.5 MHz
	LTE Band 2 (Channel Bandwidth: 10 MHz)	1855.0 ~ 1905.0 MHz
	LTE Band 2 (Channel Bandwidth: 15 MHz)	1857.5 ~ 1902.5 MHz
	LTE Band 2 (Channel Bandwidth: 20 MHz)	1860.0 ~ 1900.0 MHz
	LTE Band 4 (Channel Bandwidth: 1.4 MHz)	1710.7 ~ 1754.3 MHz
	LTE Band 4 (Channel Bandwidth: 3 MHz)	1711.5 ~ 1753.5 MHz
	LTE Band 4 (Channel Bandwidth: 5 MHz)	1712.5 ~ 1752.5 MHz
	LTE Band 4 (Channel Bandwidth: 10 MHz)	1715.0 ~ 1750.0 MHz
	LTE Band 4 (Channel Bandwidth: 15 MHz)	1717.5 ~ 1747.5 MHz
	LTE Band 4 (Channel Bandwidth: 20 MHz)	1720.0 ~ 1745.0 MHz
	LTE Band 12 (Channel Bandwidth: 1.4 MHz)	699.7 ~ 715.3 MHz
	LTE Band 12 (Channel Bandwidth: 3 MHz)	700.5 ~ 714.5 MHz
	LTE Band 12 (Channel Bandwidth: 5 MHz)	701.5 ~ 713.5 MHz
	LTE Band 12 (Channel Bandwidth: 10 MHz)	704.0 ~ 711.0 MHz
	LTE Band 13 (Channel Bandwidth: 5 MHz)	779.5 ~ 784.5 MHz
	LTE Band 13 (Channel Bandwidth: 10 MHz)	782.0 MHz
LTE 5 (Channel Bandwidth: 1.4 MHz)	824.7 ~ 848.3 MHz	
LTE 5 (Channel Bandwidth: 3 MHz)	825.5 ~ 847.5 MHz	
LTE 5 (Channel Bandwidth: 5 MHz)	826.5 ~ 846.5 MHz	
LTE 5 (Channel Bandwidth: 10 MHz)	829 ~ 844 MHz	

2. The EUT provides 1 completed transmitter and 1 receiver.

Modulation Mode	TX Function
802.11a	1TX
802.11b	1TX
802.11g	1TX
802.11n (HT20)	1TX

3. The EUT contains following accessory devices.

Product	Brand	Model	Description
Adapter	Nest	A0017	I/P: 100-240 Vac, 50/60 Hz, 0.35 A O/P: 5 Vdc, 2.5 A
Battery	Nest	N/A	3.7 Vdc, 2850 mAh
USB Cable	Nest	N/A	1.9 meter shielded cable without core

4. The above EUT information is declared by manufacturer and for more detailed features description, please refer to the manufacturer's specifications or user's manual.

3.2 Description of Test Modes

For WLAN 2.4GHz

11 channels are provided for 802.11b, 802.11g and 802.11n (HT20):

Channel	Frequency (MHz)	Channel	Frequency (MHz)
1	2412	7	2442
2	2417	8	2447
3	2422	9	2452
4	2427	10	2457
5	2432	11	2462
6	2437		

For WLAN 5GHz

5180 ~ 5240 MHz

4 channels are provided for 802.11a, 802.11n (HT20):

Channel	Frequency (MHz)	Channel	Frequency (MHz)
36	5180	44	5220
40	5200	48	5240

5260 ~ 5320 MHz

4 channels are provided for 802.11a, 802.11n (HT20):

Channel	Frequency (MHz)	Channel	Frequency (MHz)
52	5260	60	5300
56	5280	64	5320

5500 ~ 5700 MHz

11 channels are provided for 802.11a, 802.11n (HT20):

Channel	Frequency (MHz)	Channel	Frequency (MHz)
100	5500	124	5620
104	5520	128	5640
108	5540	132	5660
112	5560	136	5680
116	5580	140	5700
120	5600		

5745 ~ 5825 MHz:

5 channels are provided for 802.11a, 802.11n (HT20):

Channel	Frequency (MHz)	Channel	Frequency (MHz)
149	5745	161	5805
153	5765	165	5825
157	5785		

For Bluetooth LE

40 channels are provided to this EUT:

Channel	Freq. (MHz)	Channel	Freq. (MHz)	Channel	Freq. (MHz)	Channel	Freq. (MHz)
0	2402	10	2422	20	2442	30	2462
1	2404	11	2424	21	2444	31	2464
2	2406	12	2426	22	2446	32	2466
3	2408	13	2428	23	2448	33	2468
4	2410	14	2430	24	2450	34	2470
5	2412	15	2432	25	2452	35	2472
6	2414	16	2434	26	2454	36	2474
7	2416	17	2436	27	2456	37	2476
8	2418	18	2438	28	2458	38	2478
9	2420	19	2440	29	2460	39	2480

For 802.15.4

15 channels are provided to this EUT:

Channel	Frequency (MHz)	Channel	Frequency (MHz)
11	2405	19	2445
12	2410	20	2450
13	2415	21	2455
14	2420	22	2460
15	2425	23	2465
16	2430	24	2470
17	2435	25	2475
18	2440		

3.2.1 Test Mode Applicability and Tested Channel Detail

EUT Configure Mode	Applicable To		Description
	RE \geq 1G	RE<1G	
-	√	√	-

Where **RE \geq 1G**: Radiated Emission above 1 GHz **RE<1G**: Radiated Emission below 1 GHz

NOTE: The EUT had been pre-tested on the positioned of each 3 axis. The worst case was found when positioned on **X-plane**.

Radiated Emission Test:

- Pre-Scan has been conducted to determine the worst-case mode from all possible combinations between available modulations, data rates and antenna ports (if EUT with antenna diversity architecture).
- Following channel(s) was (were) selected for the final test as listed below.

Tested Channel of Co-location					
		Tx 2 Mode			
		WLAN 2.4GHz	WLAN 5GHz	802.15.4	WCDMA V
		802.11n (HT20)	802.11n (HT20)	--	--
Tx 1 Mode	Tested Channel	6	44	11	4233
13.56 MHz	1	V	V	V	V
802.15.4	11	V	V	--	V

Test Condition:

Applicable To	Environmental Conditions	Input Power	Tested by
RE \geq 1G	25 deg. C, 65 % RH	120 Vac, 60 Hz	Gavin Wu
RE<1G	25 deg. C, 65 % RH	120 Vac, 60 Hz	Gavin Wu

3.3 Description of Support Units

The EUT has been tested as an independent unit together with other necessary accessories or support units.

3.3.1 Configuration of System under Test

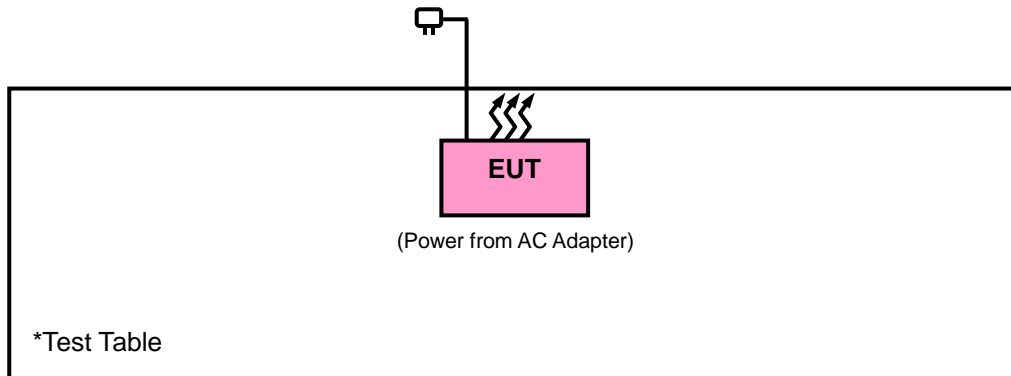

3.4 General Description of Applied Standards

The EUT is a RF Product. According to the specifications of the manufacturer, it must comply with the requirements of the following standards:

FCC Part 15, Subpart C (15.247)

558074 D01 DTS Meas Guidance v04

FCC Part 15, Subpart E (15.407)

789033 D02 General UNII Test Procedures New Rules v01r04

FCC Part 15, Subpart C (15.225)

FCC Part 15, Subpart C (15.215)

FCC 47 CFR Part 2

FCC 47 CFR Part 22

FCC 47 CFR Part 24

FCC 47 CFR Part 27

KDB 971168 D01 Power Meas License Digital Systems v02r02

ANSI/TIA/EIA-603-D 2010

ANSI C63.10-2013

All test items have been performed and recorded as per the above standards.

4 Test Types and Results

4.1 Radiated Emission and Bandedge Measurement

4.1.1 Limits of Radiated Emission and Bandedge Measurement

Radiated emissions which fall in the restricted bands must comply with the radiated emission limits specified as below table. Other emissions shall be at least 20 dB below the highest level of the desired power:

Frequencies (MHz)	Field Strength (microvolts/meter)	Measurement Distance (meters)
0.009 ~ 0.490	2400/F (kHz)	300
0.490 ~ 1.705	24000/F (kHz)	30
1.705 ~ 30.0	30	30
30 ~ 88	100	3
88 ~ 216	150	3
216 ~ 960	200	3
Above 960	500	3

NOTE:

1. The lower limit shall apply at the transition frequencies.
2. Emission level (dBuV/m) = 20 log Emission level (uV/m).
3. For frequencies above 1000 MHz, the field strength limits are based on average detector, however, the peak field strength of any emission shall not exceed the maximum permitted average limits, specified above by more than 20 dB under any condition of modulation.

Limits of Unwanted Emission Out of the Restricted Bands

Applicable To		Limit	
789033 D02 General UNII Test Procedures New Rules v01r04		Field Strength at 3 m	
		PK: 74 (dBµV/m)	AV: 54 (dBµV/m)
Frequency Band	Applicable To	EIRP Limit	Equivalent Field Strength at 3 m
5150~5250 MHz	15.407(b)(1)	PK: -27 (dBm/MHz)	PK: 68.2 (dBµV/m)
5250~5350 MHz	15.407(b)(2)		
5470~5725 MHz	15.407(b)(3)		
5725~5850 MHz	15.407(b)(4)(i)	PK:-27 (dBm/MHz) ^{*1} PK:10 (dBm/MHz) ^{*2} PK:15.6 (dBm/MHz) ^{*3} PK:27 (dBm/MHz) ^{*4}	PK: 68.2 (dBµV/m) ^{*1} PK:105.2 (dBµV/m) ^{*2} PK: 110.8 (dBµV/m) ^{*3} PK:122.2 (dBµV/m) ^{*4}
	15.407(b)(4)(ii)	Emission limits in section 15.247(d)	
^{*1} beyond 75 MHz or more above of the band edge. ^{*2} below the band edge increasing linearly to 10 dBm/MHz at 25 MHz above. ^{*3} below the band edge increasing linearly to a level of 15.6 dBm/MHz at 5 MHz above. ^{*4} from 5 MHz above or below the band edge increasing linearly to a level of 27 dBm/MHz at the band edge.			

Note:

The following formula is used to convert the equipment isotropic radiated power (eirp) to field strength:

$$E = \frac{1000000\sqrt{30P}}{3} \mu\text{V/m, where } P \text{ is the eirp (Watts).}$$

4.1.2 Test Instruments

Description & Manufacturer	Model No.	Serial No.	Date of Calibration	Due Date of Calibration
Test Receiver Agilent	N9038A	MY51210203	Feb. 17, 2017	Feb. 16, 2018
Spectrum Analyzer Agilent	N9010A	MY52220314	Dec. 16, 2016	Dec. 15, 2017
Spectrum Analyzer ROHDE & SCHWARZ	FSU43	101261	Dec. 13, 2016	Dec. 12, 2017
BILOG Antenna SCHWARZBECK	VULB9168	9168-472	Dec. 26, 2016	Dec. 27, 2017
HORN Antenna SCHWARZBECK	BBHA 9120 D	9120D-969	Dec. 12, 2016	Dec. 13, 2017
HORN Antenna SCHWARZBECK	BBHA 9170	9170-480	Dec. 14, 2016	Dec. 13, 2017
Double Ridge Guide Horn Antenna EMCO	3115	5619	Dec. 26, 2016	Dec. 27, 2017
BILOG Antenna SCHWARZBECK	VULB 9168	9168-153	Dec. 12, 2016	Dec. 13, 2017
Agilent Communications Tester-Wireless	8960 Series 10	MY53201073	Jun. 28, 2017	Jun. 27, 2018
Loop Antenna	EM-6879	269	Aug. 11, 2016	Aug. 10, 2017
Preamplifier EMCI	EMC 012645	980115	Oct. 21, 2016	Oct. 20, 2017
Preamplifier EMCI	EMC 184045	980116	Oct. 21, 2016	Oct. 20, 2017
Preamplifier EMCI	EMC 330H	980112	Oct. 21, 2016	Oct. 20, 2017
Power Meter Anritsu	ML2495A	1232002	Sep. 08, 2016	Sep. 07, 2017
Power Sensor Anritsu	MA2411B	1207325	Sep. 08, 2016	Sep. 07, 2017
RF signal cable HUBER+SUHNNER	SUCOFLEX 104	309219/4 2950114	Oct. 21, 2016	Oct. 20, 2017
RF signal cable HUBER+SUHNNER	SUCOFLEX 104	250130/4	Oct. 21, 2016	Oct. 20, 2017
RF Coaxial Cable Worken	8D-FB	Cable-Ch10-01	Oct. 21, 2016	Oct. 20, 2017
Software BV ADT	E3 6.120103	NA	NA	NA
Antenna Tower MF	MFA-440H	NA	NA	NA
Turn Table MF	MFT-201SS	NA	NA	NA
Antenna Tower & Turn Table Controller MF	MF-7802	NA	NA	NA

- Note:
- The calibration interval of the above test instruments is 12 months and the calibrations are traceable to NML/ROC and NIST/USA.
 - The test was performed in HwaYa Chamber 10.
 - The horn antenna and preamplifier (model: EMC 184045) are used only for the measurement of emission frequency above 1 GHz if tested.
 - The FCC Designation Number is TW0003. The number will be varied with the Lab location and scope as attached.
 - The IC Site Registration No. is IC7450F-10.

4.1.3 Test Procedures

- a. The EUT was placed on the top of a rotating table 0.8 meters (for below 1 GHz) / 1.5 meters (for above 1 GHz) above the ground at 3 meter chamber room for test. The table was rotated 360 degrees to determine the position of the highest radiation.
- b. The EUT was set 3 meters away from the interference-receiving antenna, which was mounted on the top of a variable-height antenna tower.
- c. The height of antenna is varied from one meter to four meters above the ground to determine the maximum value of the field strength. Both horizontal and vertical polarizations of the antenna are set to make the measurement.
- d. For each suspected emission, the EUT was arranged to its worst case and then the antenna was tuned to heights from 1 meter to 4 meters and the rotatable table was turned from 0 degrees to 360 degrees to find the maximum reading.
- e. The test-receiver system was set to quasi-peak detect function and specified bandwidth with maximum hold mode when the test frequency is below 1 GHz.
- f. The test-receiver system was set to peak and average detected function and specified bandwidth with maximum hold mode when the test frequency is above 1 GHz. If the peak reading value also meets average limit, measurement with the average detector is unnecessary.

Note:

1. The resolution bandwidth and video bandwidth of test receiver/spectrum analyzer is 120 kHz for Quasi-peak detection (QP) at frequency below 1 GHz.
2. The resolution bandwidth of test receiver/spectrum analyzer is 1 MHz and the video bandwidth is 3 MHz for Peak detection (PK) at frequency above 1 GHz.
3. The resolution bandwidth of test receiver/spectrum analyzer is 1 MHz and the video bandwidth is 1/T for Average (Duty cycle < 98 %) or 10 Hz (Duty cycle \geq 98 %) for Average detection at frequency above 1 GHz.
4. All modes of operation were investigated and the worst-case emissions are reported.

4.1.4 Deviation from Test Standard

No deviation.

4.1.5 Test Set Up

<Frequency Range below 1 GHz>

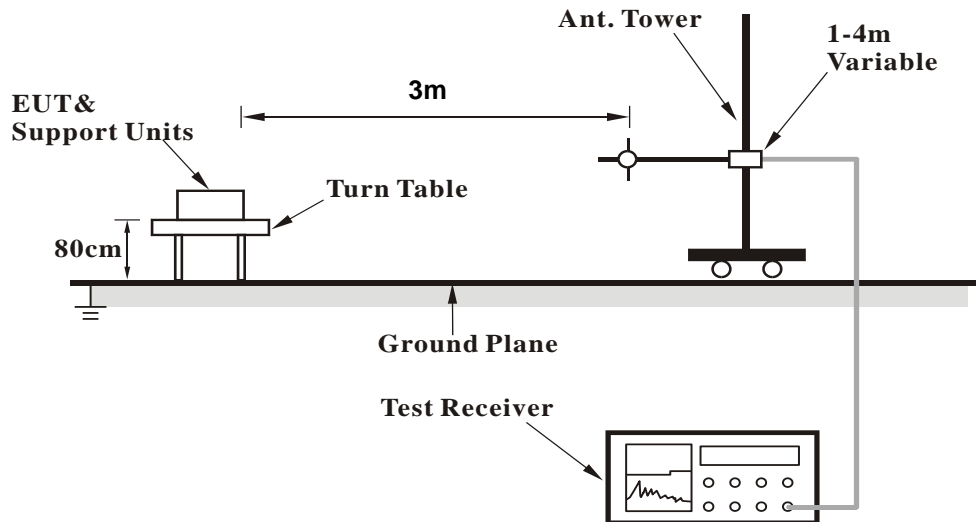

<Frequency Range above 1 GHz>

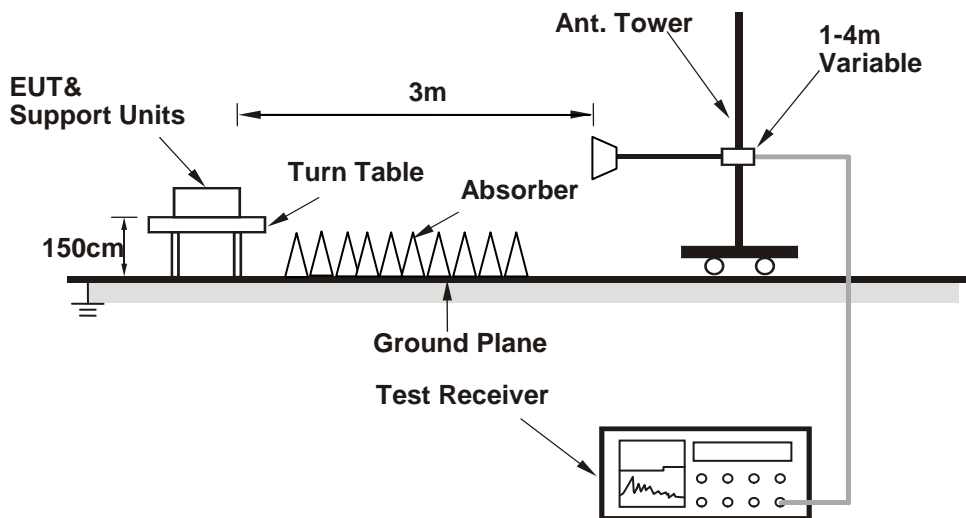

For the actual test configuration, please refer to the attached file (Test Setup Photo).

4.1.6 EUT Operating Conditions

- Placed the EUT on a testing table.
- Use the software to control the EUT under transmission condition continuously at specific channel frequency.

4.1.7 Test Results

NFC Tx + WLAN 2.4GHz_802.11n (HT20)_Ch 6 Tx

EUT Test Condition		Measurement Detail	
Input Power	120 Vac, 60 Hz	Frequency Range	30 MHz ~ 25 GHz
Environmental Conditions	25 deg. C, 65 % RH	Detector Function	Peak (PK) Average (AV)
Tested By	Gavin Wu		

Horizontal

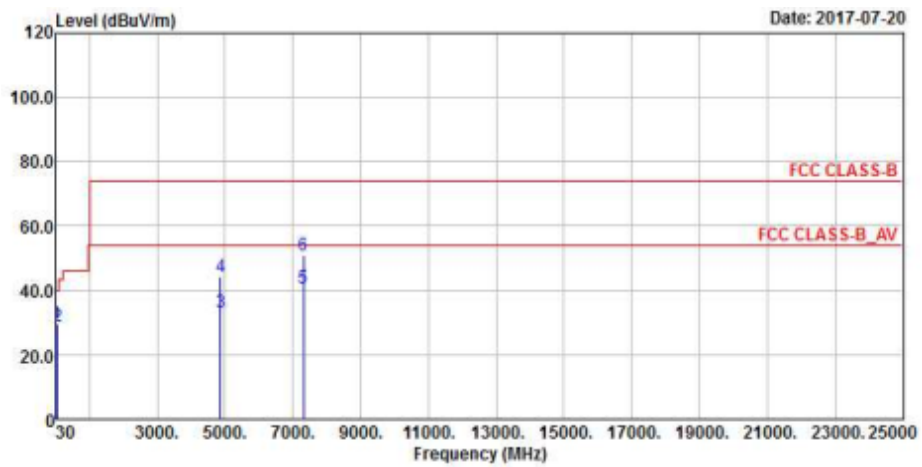

Vertical

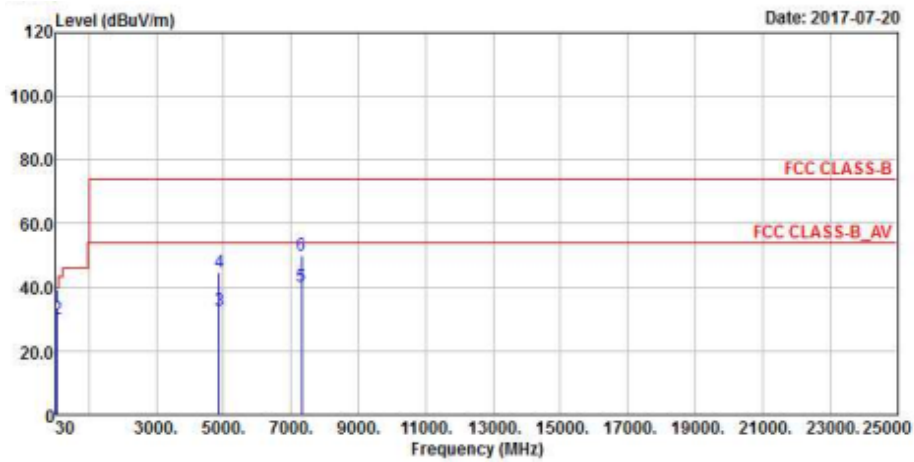

Antennal Polarity & Test Distance: Horizontal at 3 m

Frequency (MHz)	Emission Level (dBuV/m)	Read Level (dBuV)	Limit (dBuV/m)	Margin (dB)	Antenna Factor (dB/m)	Cable Loss (dB)	Preamp Factor (dB)	Antenna Height (cm)	Table Angle (Degree)	Remark
40.68	29.84	46.66	40	-10.16	13.55	0.65	31.02	133	337	Peak
54.24	28.7	46.73	40	-11.3	12.56	0.74	31.33	117	125	Peak
4874	33.39	48.53	54	-20.61	31.06	6.85	53.05	102	154	Average
4874	44.34	59.48	74	-29.66	31.06	6.85	53.05	102	154	Peak
7311	40.55	48.32	54	-13.45	35.84	8.24	51.85	105	88	Average
7311	50.89	58.66	74	-23.11	35.84	8.24	51.85	105	88	Peak

Antennal Polarity & Test Distance: Vertical at 3 m

Frequency (MHz)	Emission Level (dBuV/m)	Read Level (dBuV)	Limit (dBuV/m)	Margin (dB)	Antenna Factor (dB/m)	Cable Loss (dB)	Preamp Factor (dB)	Antenna Height (cm)	Table Angle (Degree)	Remark
40.68	33.84	50.66	40	-6.16	13.55	0.65	31.02	136	334	Peak
54.24	30.12	48.15	40	-9.88	12.56	0.74	31.33	134	329	Peak
4874	32.88	48.02	54	-21.12	31.06	6.85	53.05	103	166	Average
4874	44.63	59.77	74	-29.37	31.06	6.85	53.05	103	166	Peak
7311	40.25	48.02	54	-13.75	35.84	8.24	51.85	107	44	Average
7311	50.25	58.02	74	-23.75	35.84	8.24	51.85	107	44	Peak

Remarks:

Emission Level = Read Level + Antenna Factor + Cable Loss - Preamp Factor

Margin value = Emission level – Limit value

NFC Tx + WLAN 5GHz_802.11n (HT20)_Ch 44 Tx

EUT Test Condition		Measurement Detail	
Input Power	120 Vac, 60 Hz	Frequency Range	30 MHz ~ 25 GHz
Environmental Conditions	25 deg. C, 65 % RH	Detector Function	Peak (PK) Average (AV)
Tested By	Gavin Wu		

Horizontal

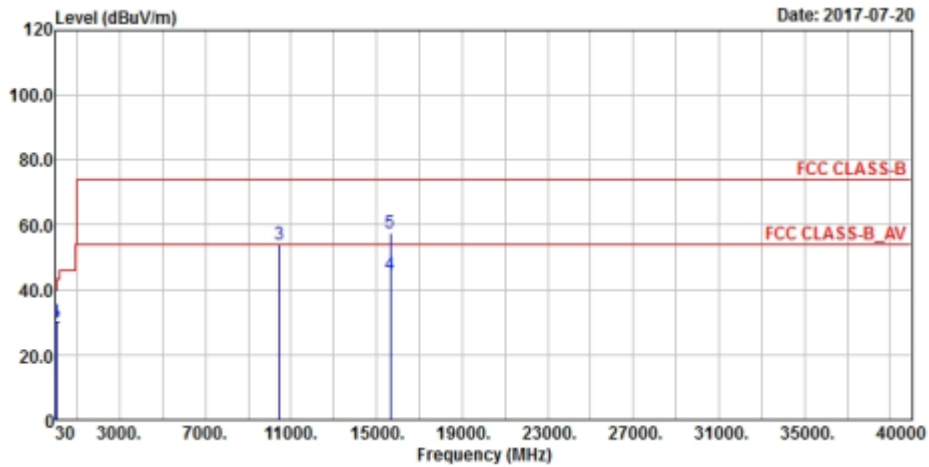

Vertical

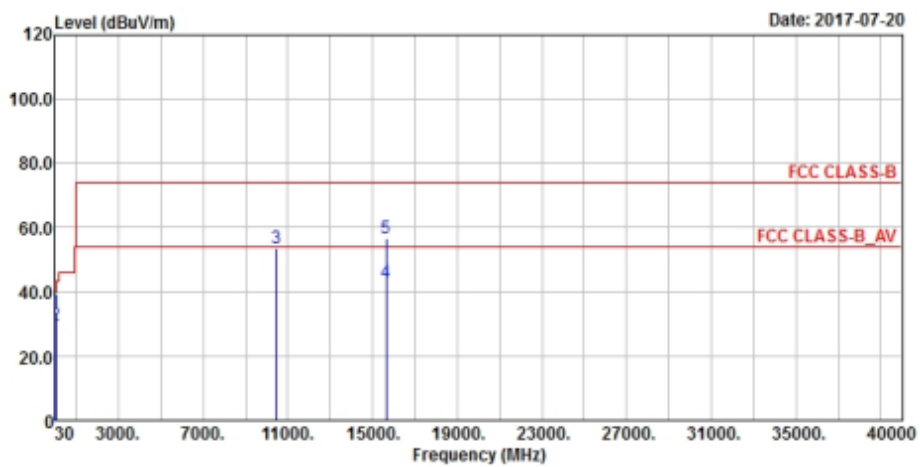

Antennal Polarity & Test Distance: Horizontal at 3 m

Frequency (MHz)	Emission Level (dBuV/m)	Read Level (dBuV)	Limit (dBuV/m)	Margin (dB)	Antenna Factor (dB/m)	Cable Loss (dB)	Preamp Factor (dB)	Antenna Height (cm)	Table Angle (Degree)	Remark
40.68	30.27	47.09	40	-9.73	13.55	0.65	31.02	112	261	Peak
54.24	28.46	46.49	40	-11.54	12.56	0.74	31.33	136	356	Peak
*10440	54.19	58.29	68.2	-14.01	39.29	9.09	52.48	109	99	Peak
15660	44.79	47.65	54	-9.21	37.77	12.52	53.15	151	223	Average
15660	57.52	60.38	74	-16.48	37.77	12.52	53.15	151	223	Peak

Antennal Polarity & Test Distance: Vertical at 3 m

Frequency (MHz)	Emission Level (dBuV/m)	Read Level (dBuV)	Limit (dBuV/m)	Margin (dB)	Antenna Factor (dB/m)	Cable Loss (dB)	Preamp Factor (dB)	Antenna Height (cm)	Table Angle (Degree)	Remark
40.68	33.86	50.68	40	-6.14	13.55	0.65	31.02	114	126	Peak
54.24	29.76	47.79	40	-10.24	12.56	0.74	31.33	117	4	Peak
*10440	53.45	57.55	68.2	-14.75	39.29	9.09	52.48	105	22	Peak
15660	42.95	45.81	54	-11.05	37.77	12.52	53.15	106	199	Average
15660	56.78	59.64	74	-17.22	37.77	12.52	53.15	106	199	Peak

Remarks:

- Emission Level = Read Level + Antenna Factor + Cable Loss - Preamp Factor
Margin value = Emission level – Limit value
- *: Out of Restricted Band

NFC Tx + 802.15.4_Ch 11 Tx

EUT Test Condition		Measurement Detail	
Input Power	120 Vac, 60 Hz	Frequency Range	30 MHz ~ 25 GHz
Environmental Conditions	25 deg. C, 65 % RH	Detector Function	Peak (PK) Average (AV)
Tested By	Gavin Wu		

Horizontal

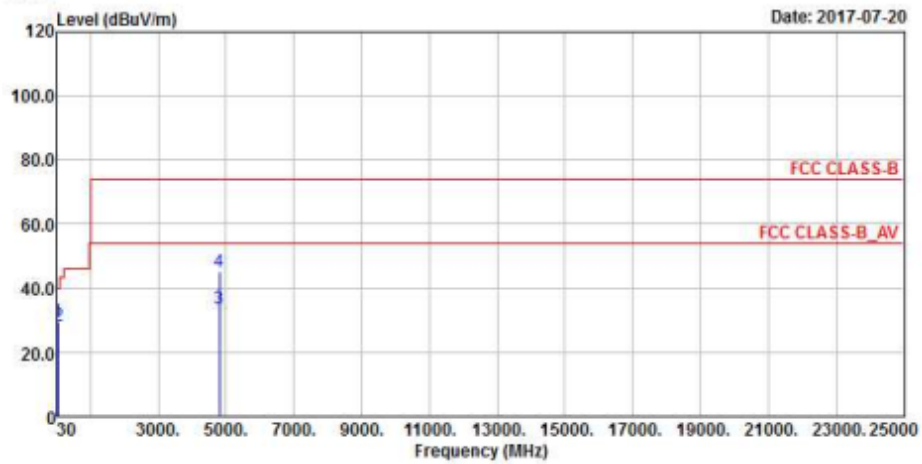

Vertical

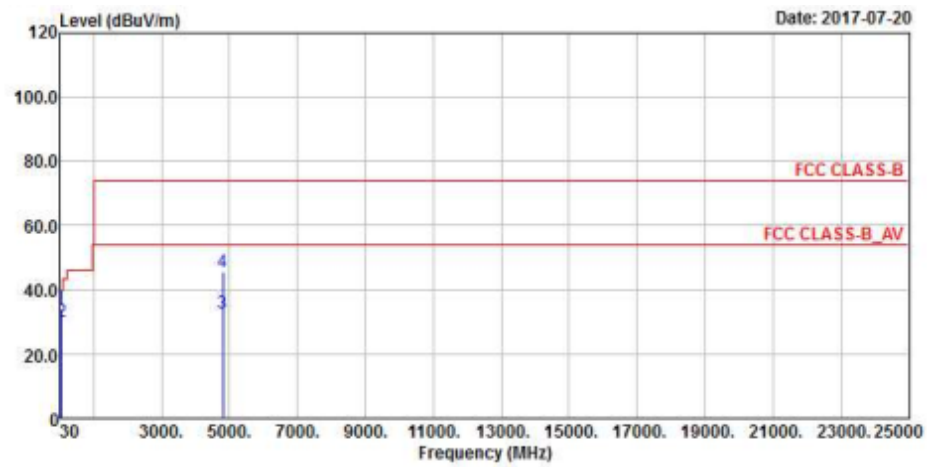

Antennal Polarity & Test Distance: Horizontal at 3 m

Frequency (MHz)	Emission Level (dBuV/m)	Read Level (dBuV)	Limit (dBuV/m)	Margin (dB)	Antenna Factor (dB/m)	Cable Loss (dB)	Preamp Factor (dB)	Antenna Height (cm)	Table Angle (Degree)	Remark
40.68	29.46	46.28	40	-10.54	13.55	0.65	31.02	127	356	Peak
54.24	28.32	46.35	40	-11.68	12.56	0.74	31.33	117	181	Peak
4810	33.5	48.84	54	-20.5	30.97	6.79	53.1	110	120	Average
4810	45.32	60.66	74	-28.68	30.97	6.79	53.1	110	120	Peak

Antennal Polarity & Test Distance: Vertical at 3 m

Frequency (MHz)	Emission Level (dBuV/m)	Read Level (dBuV)	Limit (dBuV/m)	Margin (dB)	Antenna Factor (dB/m)	Cable Loss (dB)	Preamp Factor (dB)	Antenna Height (cm)	Table Angle (Degree)	Remark
40.68	33.96	50.78	40	-6.04	13.55	0.65	31.02	122	195	Peak
54.24	30	48.03	40	-10	12.56	0.74	31.33	101	159	Peak
4810	32.92	48.26	54	-21.08	30.97	6.79	53.1	108	145	Average
4810	45.44	60.78	74	-28.56	30.97	6.79	53.1	108	145	Peak

Remarks:

Emission Level = Read Level + Antenna Factor + Cable Loss - Preamp Factor

Margin value = Emission level – Limit value

NFC Tx + WCDMA V_Ch 4233 Tx

EUT Test Condition		Measurement Detail	
Input Power	120 Vac, 60 Hz	Frequency Range	30 MHz ~ 25 GHz
Environmental Conditions	25 deg. C, 65 % RH	Detector Function	Peak (PK) Average (AV)
Tested By	Gavin Wu		

Horizontal

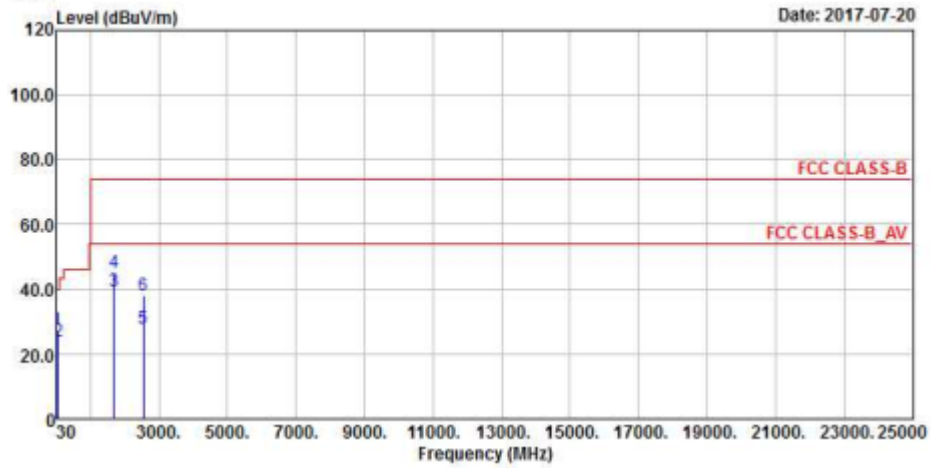

Vertical

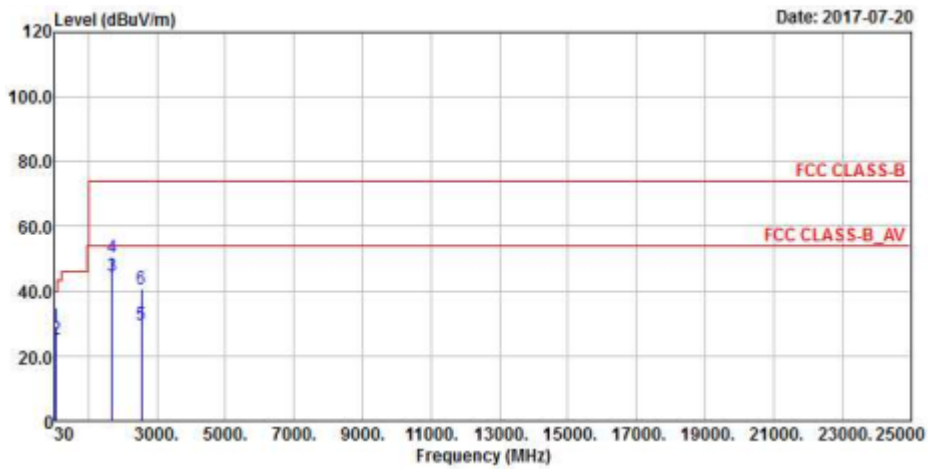

Antennal Polarity & Test Distance: Horizontal at 3 m

Frequency (MHz)	Emission Level (dBuV/m)	Read Level (dBuV)	Limit (dBuV/m)	Margin (dB)	Antenna Factor (dB/m)	Cable Loss (dB)	Preamp Factor (dB)	Antenna Height (cm)	Table Angle (Degree)	Remark
40.68	27.5	44.32	40	-12.5	13.55	0.65	31.02	119	160	Peak
54.24	23.95	41.98	40	-16.05	12.56	0.74	31.33	106	111	Peak
1693.2	39.59	63.66	54	-14.41	25.68	3.82	53.57	105	117	Average
1693.2	45.15	69.22	74	-28.85	25.68	3.82	53.57	105	117	Peak
2539.8	27.97	49.56	54	-26.03	27.33	4.68	53.6	107	109	Average
2539.8	37.88	59.47	74	-36.12	27.33	4.68	53.6	107	109	Peak

Antennal Polarity & Test Distance: Vertical at 3 m

Frequency (MHz)	Emission Level (dBuV/m)	Read Level (dBuV)	Limit (dBuV/m)	Margin (dB)	Antenna Factor (dB/m)	Cable Loss (dB)	Preamp Factor (dB)	Antenna Height (cm)	Table Angle (Degree)	Remark
40.68	29.31	46.13	40	-10.69	13.55	0.65	31.02	102	343	Peak
54.24	25.08	43.11	40	-14.92	12.56	0.74	31.33	102	343	Peak
1693.2	44.52	68.59	54	-9.48	25.68	3.82	53.57	100	235	Average
1693.2	50.37	74.44	74	-23.63	25.68	3.82	53.57	100	235	Peak
2539.8	29.61	51.2	54	-24.39	27.33	4.68	53.6	100	355	Average
2539.8	40.53	62.12	74	-33.47	27.33	4.68	53.6	100	355	Peak

Remarks:

Emission Level = Read Level + Antenna Factor + Cable Loss - Preamp Factor

Margin value = Emission level – Limit value

802.15.4_Ch 11 Tx + WCDMA V_Ch 4233 Tx

EUT Test Condition		Measurement Detail	
Input Power	120 Vac, 60 Hz	Frequency Range	30 MHz ~ 25 GHz
Environmental Conditions	25 deg. C, 65 % RH	Detector Function	Peak (PK) Average (AV)
Tested By	Gavin Wu		

Horizontal

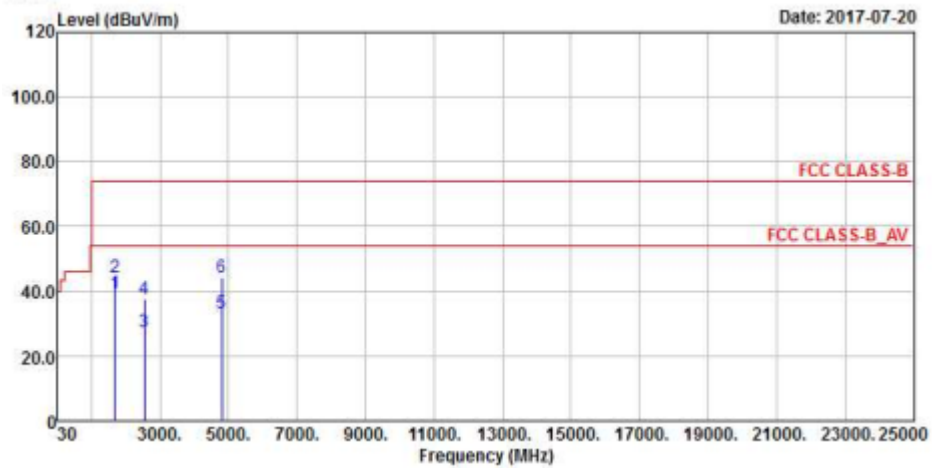

Vertical

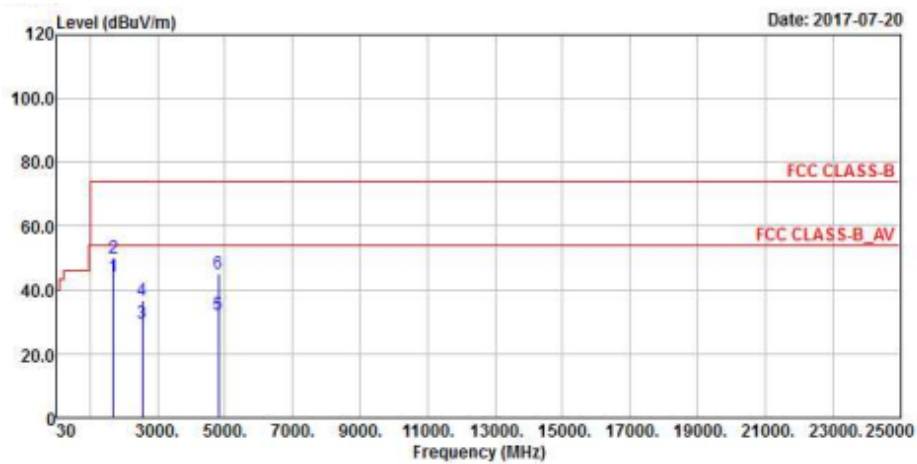

Antennal Polarity & Test Distance: Horizontal at 3 m

Frequency (MHz)	Emission Level (dBuV/m)	Read Level (dBuV)	Limit (dBuV/m)	Margin (dB)	Antenna Factor (dB/m)	Cable Loss (dB)	Preamp Factor (dB)	Antenna Height (cm)	Table Angle (Degree)	Remark
1693.2	39.44	63.51	54	-14.56	25.68	3.82	53.57	130	225	Average
1693.2	44.26	68.33	74	-29.74	25.68	3.82	53.57	130	225	Peak
2539.8	27.44	49.03	54	-26.56	27.33	4.68	53.6	103	310	Average
2539.8	37.65	59.24	74	-36.35	27.33	4.68	53.6	103	310	Peak
4810	33.22	48.56	54	-20.78	30.97	6.79	53.1	120	184	Average
4810	44.3	59.64	74	-29.7	30.97	6.79	53.1	120	184	Peak

Antennal Polarity & Test Distance: Vertical at 3 m

Frequency (MHz)	Emission Level (dBuV/m)	Read Level (dBuV)	Limit (dBuV/m)	Margin (dB)	Antenna Factor (dB/m)	Cable Loss (dB)	Preamp Factor (dB)	Antenna Height (cm)	Table Angle (Degree)	Remark
1693.2	44.38	68.45	54	-9.62	25.68	3.82	53.57	151	189	Average
1693.2	50.22	74.29	74	-23.78	25.68	3.82	53.57	151	189	Peak
2539.8	29.48	51.07	54	-24.52	27.33	4.68	53.6	100	184	Average
2539.8	36.77	58.36	74	-37.23	27.33	4.68	53.6	100	184	Peak
4810	32.15	47.49	54	-21.85	30.97	6.79	53.1	103	129	Average
4810	45.37	60.71	74	-28.63	30.97	6.79	53.1	103	129	Peak

Remarks:

Emission Level = Read Level + Antenna Factor + Cable Loss - Preamp Factor

Margin value = Emission level – Limit value

802.15.4_Ch 11 Tx + WLAN 2.4GHz_802.11n (HT20)_Ch 6 Tx

EUT Test Condition		Measurement Detail	
Input Power	120 Vac, 60 Hz	Frequency Range	30 MHz ~ 25 GHz
Environmental Conditions	25 deg. C, 65 % RH	Detector Function	Peak (PK) Average (AV)
Tested By	Gavin Wu		

Horizontal

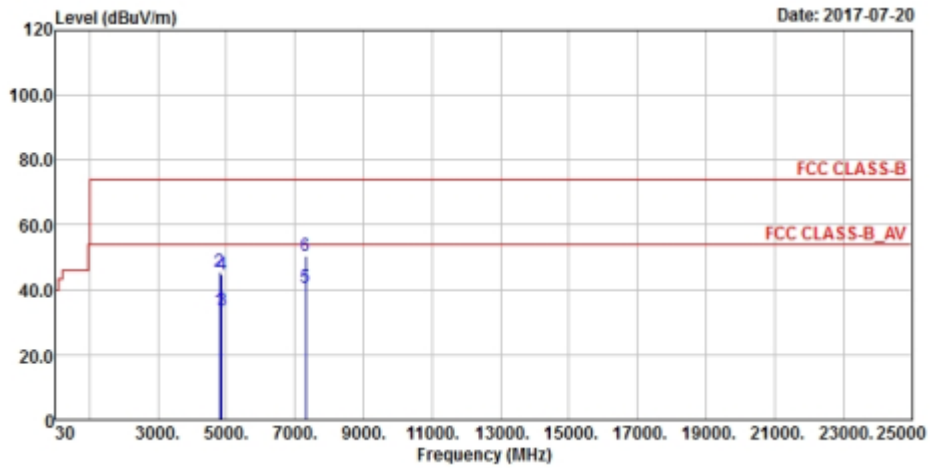

Vertical

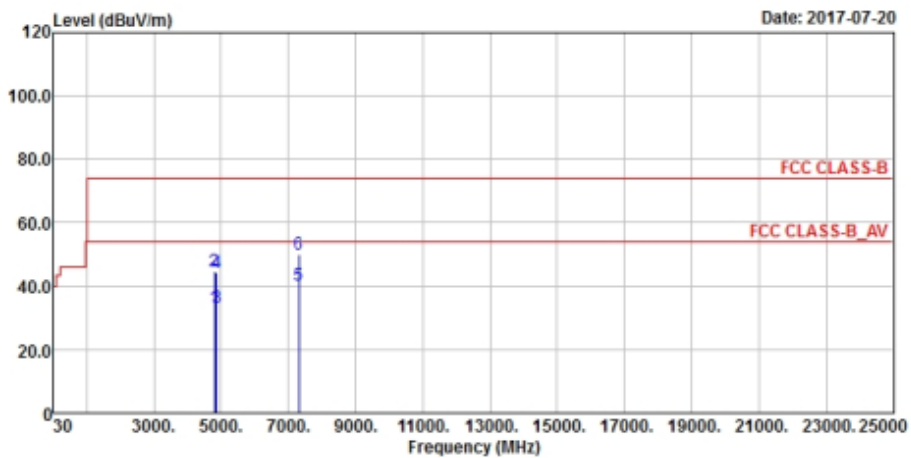

Antennal Polarity & Test Distance: Horizontal at 3 m

Frequency (MHz)	Emission Level (dBuV/m)	Read Level (dBuV)	Limit (dBuV/m)	Margin (dB)	Antenna Factor (dB/m)	Cable Loss (dB)	Preamp Factor (dB)	Antenna Height (cm)	Table Angle (Degree)	Remark
4810	33.65	48.99	54	-20.35	30.97	6.79	53.1	102	188	Average
4810	45.47	60.81	74	-28.53	30.97	6.79	53.1	102	188	Peak
4874	33.48	48.62	54	-20.52	31.06	6.85	53.05	100	312	Average
4874	44.81	59.95	74	-29.19	31.06	6.85	53.05	100	312	Peak
7311	40.89	48.66	54	-13.11	35.84	8.24	51.85	112	326	Average
7311	50.34	58.11	74	-23.66	35.84	8.24	51.85	112	326	Peak

Antennal Polarity & Test Distance: Vertical at 3 m

Frequency (MHz)	Emission Level (dBuV/m)	Read Level (dBuV)	Limit (dBuV/m)	Margin (dB)	Antenna Factor (dB/m)	Cable Loss (dB)	Preamp Factor (dB)	Antenna Height (cm)	Table Angle (Degree)	Remark
4810	33.35	48.69	54	-20.65	30.97	6.79	53.1	102	333	Average
4810	44.85	60.19	74	-29.15	30.97	6.79	53.1	102	333	Peak
4874	33.26	48.4	54	-20.74	31.06	6.85	53.05	106	194	Average
4874	44.29	59.43	74	-29.71	31.06	6.85	53.05	106	194	Peak
7311	40.39	48.16	54	-13.61	35.84	8.24	51.85	109	187	Average
7311	50.25	58.02	74	-23.75	35.84	8.24	51.85	109	187	Peak

Remarks:

Emission Level = Read Level + Antenna Factor + Cable Loss - Preamp Factor

Margin value = Emission level – Limit value

802.15.4_Ch 11 Tx + WLAN 5GHz_802.11n (HT20)_Ch 44 Tx

EUT Test Condition		Measurement Detail	
Input Power	120 Vac, 60 Hz	Frequency Range	30 MHz ~ 25 GHz
Environmental Conditions	25 deg. C, 65 % RH	Detector Function	Peak (PK) Average (AV)
Tested By	Gavin Wu		

Horizontal

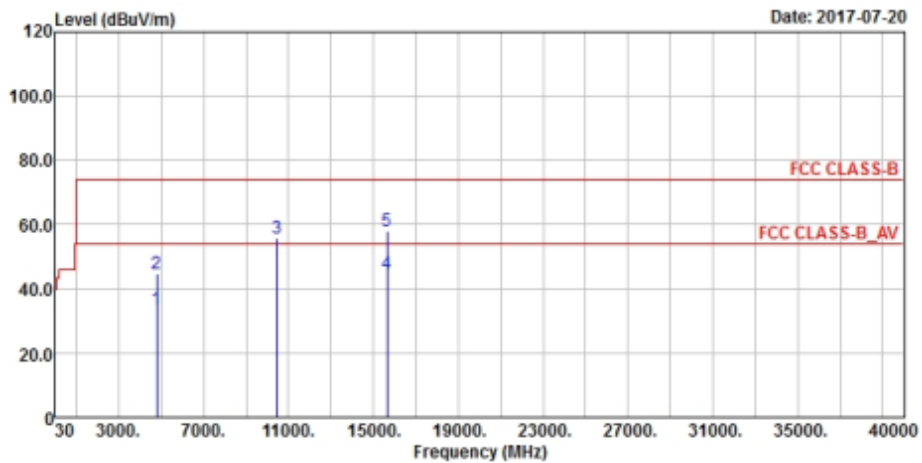

Vertical

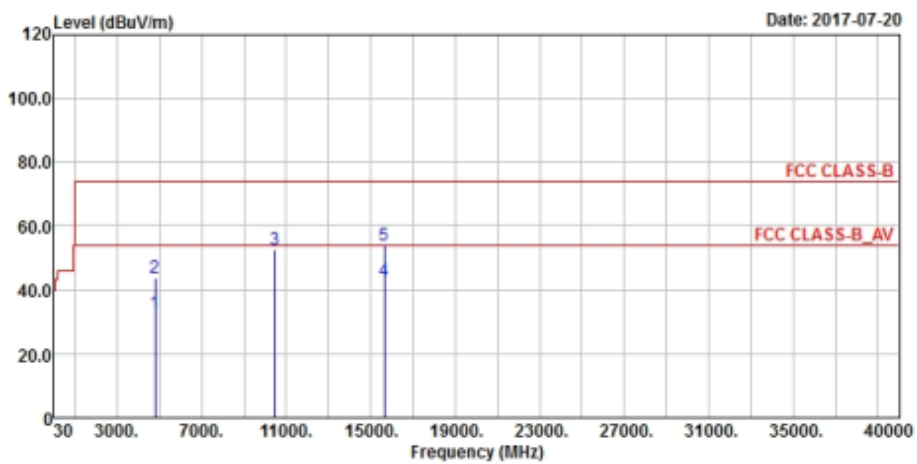

Antennal Polarity & Test Distance: Horizontal at 3 m

Frequency (MHz)	Emission Level (dBuV/m)	Read Level (dBuV)	Limit (dBuV/m)	Margin (dB)	Antenna Factor (dB/m)	Cable Loss (dB)	Preamp Factor (dB)	Antenna Height (cm)	Table Angle (Degree)	Remark
4810	33.54	48.88	54	-20.46	30.97	6.79	53.1	112	244	Average
4810	44.51	59.85	74	-29.49	30.97	6.79	53.1	112	244	Peak
*10440	55.6	59.7	68.2	-12.6	39.29	9.09	52.48	100	121	Peak
15660	44.92	47.78	54	-9.08	37.77	12.52	53.15	149	213	Average
15660	57.92	60.78	74	-16.08	37.77	12.52	53.15	149	213	Peak

Antennal Polarity & Test Distance: Vertical at 3 m

Frequency (MHz)	Emission Level (dBuV/m)	Read Level (dBuV)	Limit (dBuV/m)	Margin (dB)	Antenna Factor (dB/m)	Cable Loss (dB)	Preamp Factor (dB)	Antenna Height (cm)	Table Angle (Degree)	Remark
4810	32.78	48.12	54	-21.22	30.97	6.79	53.1	110	128	Average
4810	43.76	59.1	74	-30.24	30.97	6.79	53.1	110	128	Peak
*10440	52.68	56.78	68.2	-15.52	39.29	9.09	52.48	100	174	Peak
15660	43.11	45.97	54	-10.89	37.77	12.52	53.15	116	221	Average
15660	53.84	56.7	74	-20.16	37.77	12.52	53.15	116	221	Peak

Remarks:

- Emission Level = Read Level + Antenna Factor + Cable Loss - Preamp Factor
Margin value = Emission level – Limit value
- *: Out of Restricted Band

5 Pictures of Test Arrangements

Please refer to the attached file (Test Setup Photo).

Appendix – Information on the Testing Laboratories

We, Bureau Veritas Consumer Products Services (H.K.) Ltd., Taoyuan Branch, were founded in 1988 to provide our best service in EMC, Radio, Telecom and Safety consultation. Our laboratories are accredited and approved according to ISO/IEC 17025.

If you have any comments, please feel free to contact us at the following:

Linko EMC/RF Lab

Tel: 886-2-26052180

Fax: 886-2-26051924

Hsin Chu EMC/RF/Telecom Lab

Tel: 886-3-6668565

Fax: 886-3-6668323

Hwa Ya EMC/RF/Safety Lab

Tel: 886-3-3183232

Fax: 886-3-3270892

Email: service.adt@tw.bureauveritas.com

Web Site: www.bureauveritas-adt.com

The address and road map of all our labs can be found in our web site also.

--- END ---