

FCC Test Report

Report No.: RF150626C12

FCC ID: ZQ6-AP6212SD

Test Model: AP6212SD

Received Date: June 26, 2015

Test Date: Aug. 27 to Sep. 02, 2015

Issued Date: July 29, 2016

Applicant: Ampak Technology Inc.

Address: No1. Jen Ai Road. Hokou, Hsinchu, Taiwan,30352

Issued By: Bureau Veritas Consumer Products Services (H.K.) Ltd., Taoyuan Branch
Hsin Chu Laboratory

Lab Address: No. 81-1, Lu Liao Keng, 9th Ling, Wu Lung Tsuen, Chiung Lin Hsiang, Hsin
Chu Hsien 307, Taiwan R.O.C.

Test Location (1): No. 81-1, Lu Liao Keng, 9th Ling, Wu Lung Tsuen, Chiung Lin Hsiang, Hsin
Chu Hsien 307, Taiwan R.O.C.

Test Location (2): No. 49, Ln. 206, Wende Rd., Shangshan Tsuen, Chiung Lin Hsiang, Hsin
Chu Hsien 307, Taiwan R.O.C.

Test Location (3): E-2, No.1, Li Hsin 1st Road, Hsinchu Science Park, Hsinchu City 300,
Taiwan R.O.C.



This report is for your exclusive use. Any copying or replication of this report to or for any other person or entity, or use of our name or trademark, is permitted only with our prior written permission. This report sets forth our findings solely with respect to the test samples identified herein. The results set forth in this report are not indicative or representative of the quality or characteristics of the lot from which a test sample was taken or any similar or identical product unless specifically and expressly noted. Our report includes all of the tests requested by you and the results thereof based upon the information that you provided to us. You have 60 days from date of issuance of this report to notify us of any material error or omission caused by our negligence, provided, however, that such notice shall be in writing and shall specifically address the issue you wish to raise. A failure to raise such issue within the prescribed time shall constitute your unqualified acceptance of the completeness of this report, the tests conducted and the correctness of the report contents. Unless specific mention, the uncertainty of measurement has been explicitly taken into account to declare the compliance or non-compliance to the specification. The report must not be used by the client to claim product certification, approval, or endorsement by TAF or any government agencies.

Table of Contents

Release Control Record	4
1 Certificate of Conformity	5
2 Summary of Test Results	6
2.1 Measurement Uncertainty.....	6
2.2 Modification Record.....	6
3 General Information	7
3.1 General Description of EUT.....	7
3.2 Description of Test Modes.....	8
3.2.1 Test Mode Applicability and Tested Channel Detail.....	9
3.3 Duty Cycle of Test Signal.....	11
3.4 Description of Support Units.....	12
3.4.1 Configuration of System under Test.....	12
3.5 General Description of Applied Standards.....	13
4 Test Types and Results	14
4.1 Radiated Emission and Bandedge Measurement.....	14
4.1.1 Limits of Radiated Emission and Bandedge Measurement.....	14
4.1.2 Test Instruments.....	15
4.1.3 Test Procedures.....	16
4.1.4 Deviation from Test Standard.....	16
4.1.5 Test Setup.....	17
4.1.6 EUT Operating Conditions.....	17
4.1.7 Test Results.....	18
4.2 Conducted Emission Measurement.....	28
4.2.1 Limits of Conducted Emission Measurement.....	28
4.2.2 Test Instruments.....	28
4.2.3 Test Procedures.....	29
4.2.4 Deviation from Test Standard.....	29
4.2.5 Test Setup.....	29
4.2.6 EUT Operating Conditions.....	29
4.2.7 Test Results.....	30
4.3 6dB Bandwidth Measurement.....	32
4.3.1 Limits of 6dB Bandwidth Measurement.....	32
4.3.2 Test Setup.....	32
4.3.3 Test Instruments.....	32
4.3.4 Test Procedure.....	32
4.3.5 Deviation from Test Standard.....	32
4.3.6 EUT Operating Conditions.....	32
4.3.7 Test Result.....	33
4.4 Conducted Output Power Measurement.....	35
4.4.1 Limits of Conducted Output Power Measurement.....	35
4.4.2 Test Setup.....	35
4.4.3 Test Instruments.....	35
4.4.4 Test Procedures.....	35
4.4.5 Deviation from Test Standard.....	35
4.4.6 EUT Operating Conditions.....	35
4.4.7 Test Results.....	36
4.5 Power Spectral Density Measurement.....	38
4.5.1 Limits of Power Spectral Density Measurement.....	38
4.5.2 Test Setup.....	38
4.5.3 Test Instruments.....	38
4.5.4 Test Procedure.....	38
4.5.5 Deviation from Test Standard.....	38
4.5.6 EUT Operating Condition.....	38



4.5.7 Test Results	39
4.6 Conducted Out of Band Emission Measurement	41
4.6.1 Limits of Conducted Out of Band Emission Measurement	41
4.6.2 Test Setup	41
4.6.3 Test Instruments	41
4.6.4 Test Procedure	41
4.6.5 Deviation from Test Standard	41
4.6.6 EUT Operating Condition	41
4.6.7 Test Results	41
5 Pictures of Test Arrangements	45
Appendix – Information on the Testing Laboratories	46



Release Control Record

Issue No.	Description	Date Issued
RF150626C12	Original release.	July 29, 2016

1 Certificate of Conformity

Product: WLAN module

Brand: Ampak

Test Model: AP6212SD

Sample Status: ENGINEERING SAMPLE

Applicant: Ampak Technology Inc.

Test Date: Aug. 27 to Sep. 02, 2015

Standards: 47 CFR FCC Part 15, Subpart C (Section 15.247)
ANSI C63.10: 2013

The above equipment has been tested by **Bureau Veritas Consumer Products Services (H.K.) Ltd., Taoyuan Branch**, and found compliance with the requirement of the above standards. The test record, data evaluation & Equipment Under Test (EUT) configurations represented herein are true and accurate accounts of the measurements of the sample's EMC characteristics under the conditions specified in this report.

Prepared by :  , **Date:** July 29, 2016
Claire Kuan / Specialist

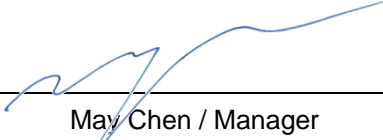
Approved by :  , **Date:** July 29, 2016
May Chen / Manager

2 Summary of Test Results

47 CFR FCC Part 15, Subpart C (SECTION 15.247)			
FCC Clause	Test Item	Result	Remarks
15.207	AC Power Conducted Emission	PASS	Meet the requirement of limit. Minimum passing margin is -7.24dB at 0.18125MHz.
15.205 / 15.209 / 15.247(d)	Radiated Emissions and Band Edge Measurement	PASS	Meet the requirement of limit. Minimum passing margin is -0.2dB at 2390.00MHz, 2483.50MHz.
15.247(d)	Antenna Port Emission	PASS	Meet the requirement of limit.
15.247(a)(2)	6dB bandwidth	PASS	Meet the requirement of limit.
15.247(b)	Conducted power	PASS	Meet the requirement of limit.
15.247(e)	Power Spectral Density	PASS	Meet the requirement of limit.
15.203	Antenna Requirement	PASS	Antenna connector is I-PEX MHF4 not a standard connector.

2.1 Measurement Uncertainty

Where relevant, the following measurement uncertainty levels have been estimated for tests performed on the EUT as specified in CISPR 16-4-2:

Measurement	Frequency	Expanded Uncertainty (k=2) (\pm)
Conducted Emissions at mains ports	150kHz ~ 30MHz	2.86 dB
Radiated Emissions up to 1 GHz	30MHz ~ 1GHz	5.37 dB
Radiated Emissions above 1 GHz	1GHz ~6GHz	3.65 dB
	6GHz ~ 18GHz	3.88 dB
	18GHz ~ 40GHz	4.11 dB

2.2 Modification Record

There were no modifications required for compliance.

3 General Information

3.1 General Description of EUT

Product	WLAN module
Brand	Ampak
Test Model	AP6212SD
Status of EUT	ENGINEERING SAMPLE
Test Software Version	command.txt
Power Supply Rating	3.3Vdc from host equipment
Modulation Type	CCK, DQPSK, DBPSK for DSSS 64QAM, 16QAM, QPSK, BPSK for OFDM
Modulation Technology	DSSS, OFDM
Transfer Rate	802.11b: up to 11Mbps 802.11a: up to 54Mbps 802.11n: up to 150Mbps
Operating Frequency	2412 ~ 2462MHz
Number of Channel	11
Output Power	802.11b: 158.489mW 802.11g: 224.388mW 802.11n (HT20): 217.27mW
Antenna Type	Refer to Note
Antenna Connector	Refer to Note
Accessory Device	NA
Data Cable Supplied	NA

Note:

1. There are Bluetooth technology and WLAN technology used for the EUT.
2. WLAN and BT technology can't transmit at same time.
3. The antenna provided to the EUT, please refer to the following table:

Brand	Model	Gain (dBi) Excluding cable loss	Cable Loss (dB)	Frequency range (MHz to MHz)	Antenna Type	Connector Type
INPAQ	NA	3.53	2.4G: 0.5 5G: 1	2400~2500	PIFA	I-PEX MHF4

4. The EUT incorporates a SISO function.

MODULATION MODE	DATA RATE (MCS)	TX & RX CONFIGURATION	
802.11b	1 ~ 11Mbps	1TX	1RX
802.11g	6 ~ 54Mbps	1TX	1RX
802.11n (HT20)	MCS 0~7	1TX	1RX

5. The above EUT information is declared by manufacturer and for more detailed features description, please refer to the manufacturer's specifications or user's manual.

3.2 Description of Test Modes

11 channels are provided for 802.11b, 802.11g and 802.11n (HT20):

Channel	Frequency	Channel	Frequency
1	2412MHz	7	2442MHz
2	2417MHz	8	2447MHz
3	2422MHz	9	2452MHz
4	2427MHz	10	2457MHz
5	2432MHz	11	2462MHz
6	2437MHz		

3.2.1 Test Mode Applicability and Tested Channel Detail

EUT CONFIGURE MODE	APPLICABLE TO				DESCRIPTION
	RE \geq 1G	RE<1G	PLC	APCM	
-	√	√	√	√	-

Where RE \geq 1G: Radiated Emission above 1GHz & Bandedge Measurement
 RE<1G: Radiated Emission below 1GHz
 PLC: Power Line Conducted Emission
 APCM: Antenna Port Conducted Measurement

NOTE: The EUT had been pre-tested on the positioned of each 3 axis. The worst case was found when positioned on X-plane.

Radiated Emission Test (Above 1GHz):

- Pre-Scan has been conducted to determine the worst-case mode from all possible combinations between available modulations, data rates and antenna ports (if EUT with antenna diversity architecture).
- Following channel(s) was (were) selected for the final test as listed below.

MODE	AVAILABLE CHANNEL	TESTED CHANNEL	MODULATION TECHNOLOGY	MODULATION TYPE	DATA RATE (Mbps)
802.11b	1 to 11	1, 6, 11	DSSS	DBPSK	1
802.11g	1 to 11	1, 6, 11	OFDM	BPSK	6
802.11n (HT20)	1 to 11	1, 6, 11	OFDM	BPSK	6.5

Radiated Emission Test (Below 1GHz):

- Pre-Scan has been conducted to determine the worst-case mode from all possible combinations between available modulations, data rates and antenna ports (if EUT with antenna diversity architecture).
- Following channel(s) was (were) selected for the final test as listed below.

MODE	AVAILABLE CHANNEL	TESTED CHANNEL	MODULATION TECHNOLOGY	MODULATION TYPE	DATA RATE (Mbps)
802.11g	1 to 11	6	OFDM	BPSK	6

Power Line Conducted Emission Test:

- Pre-Scan has been conducted to determine the worst-case mode from all possible combinations between available modulations, data rates and antenna ports (if EUT with antenna diversity architecture).
- Following channel(s) was (were) selected for the final test as listed below.

MODE	AVAILABLE CHANNEL	TESTED CHANNEL	MODULATION TECHNOLOGY	MODULATION TYPE	DATA RATE (Mbps)
802.11g	1 to 11	6	OFDM	BPSK	6

Antenna Port Conducted Measurement:

- This item includes all test value of each mode, but only includes spectrum plot of worst value of each mode.
- Pre-Scan has been conducted to determine the worst-case mode from all possible combinations between available modulations, data rates and antenna ports (if EUT with antenna diversity architecture).
- Following channel(s) was (were) selected for the final test as listed below.

MODE	AVAILABLE CHANNEL	TESTED CHANNEL	MODULATION TECHNOLOGY	MODULATION TYPE	DATA RATE (Mbps)
802.11b	1 to 11	1, 6, 11	DSSS	DBPSK	1
802.11g	1 to 11	1, 6, 11	OFDM	BPSK	6
802.11n (HT20)	1 to 11	1, 6, 11	OFDM	BPSK	6.5

Test Condition:

APPLICABLE TO	ENVIRONMENTAL CONDITIONS	INPUT POWER (SYSTEM)	TESTED BY
RE \geq 1G	24deg. C, 67%RH	120Vac, 60Hz	Weiwei Lo
RE $<$ 1G	24deg. C, 68%RH	120Vac, 60Hz	Weiwei Lo
PLC	26deg. C, 65%RH	120Vac, 60Hz	JyunChun.Lin
APCM	25deg. C, 60%RH	120Vac, 60Hz	Anderson Chen

3.3 Duty Cycle of Test Signal

Duty cycle of test signal is $\geq 98\%$, duty factor is not required.

802.11b: Duty cycle = $0.846/0.861 = 0.983$

802.11g: Duty cycle = $1.395/1.418 = 0.984$

802.11n (HT20): Duty cycle = $1.427/1.448 = 0.985$



3.4 Description of Support Units

The EUT has been tested as an independent unit together with other necessary accessories or support units. The following support units or accessories were used to form a representative test configuration during the tests.

ID	Product	Brand	Model No.	Serial No.	FCC ID	Remarks
A.	Personal Computer	ASUS	P5KPL	NA	NA	Provided by Lab
B.	Test tool	AMPAK Technology	NA	NA	NA	Supplied by Client
C.	Test tool	AMPAK Technology	NA	NA	NA	Supplied by Client
D.	Connector	AMPAK Technology	NA	NA	NA	Supplied by Client
E.	Notebook Computer	DELL	E5430	4YV4VY1	NA	Provided by Lab

Note:

1. All power cords of the above support units are non-shielded (1.8m).

ID	Descriptions	Qty.	Length (m)	Shielding (Yes/No)	Cores (Qty.)	Remarks
1.	mini USB	1	1.8	Yes	0	Provided by Lab
2.	RJ45	1	10	No	0	Provided by Lab
3.	Data	1	1	No	0	Supplied by Client
4.	mini USB	1	1.2	Yes	0	Provided by Lab

Note: The core(s) is(are) originally attached to the cable(s).

3.4.1 Configuration of System under Test

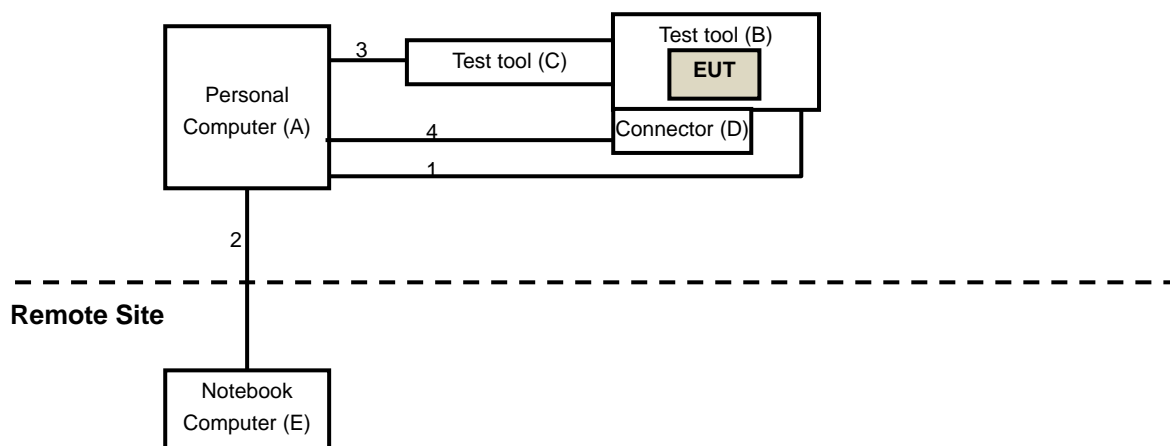

3.5 General Description of Applied Standards

The EUT is a RF Product. According to the specifications of the manufacturer, it must comply with the requirements of the following standards:

FCC Part 15, Subpart C (15.247)

558074 D01 DTS Meas Guidance v03r05

ANSI C63.10-2013

All test items have been performed and recorded as per the above standards.

4 Test Types and Results

4.1 Radiated Emission and Bandedge Measurement

4.1.1 Limits of Radiated Emission and Bandedge Measurement

Radiated emissions which fall in the restricted bands must comply with the radiated emission limits specified as below table. Other emissions shall be at least 20dB below the highest level of the desired power:

Frequencies (MHz)	Field Strength (microvolts/meter)	Measurement Distance (meters)
0.009 ~ 0.490	2400/F(kHz)	300
0.490 ~ 1.705	24000/F(kHz)	30
1.705 ~ 30.0	30	30
30 ~ 88	100	3
88 ~ 216	150	3
216 ~ 960	200	3
Above 960	500	3

NOTE:

1. The lower limit shall apply at the transition frequencies.
2. Emission level (dBuV/m) = 20 log Emission level (uV/m).
3. For frequencies above 1000MHz, the field strength limits are based on average detector, however, the peak field strength of any emission shall not exceed the maximum permitted average limits, specified above by more than 20dB under any condition of modulation.



4.1.2 Test Instruments

DESCRIPTION & MANUFACTURER	MODEL NO.	SERIAL NO.	CALIBRATED DATE	CALIBRATED UNTIL
Test Receiver Agilent	N9038A	MY51210105	July 24, 2015	July 23, 2016
Pre-Amplifier Mini-Circuits	ZFL-1000VH2 B	AMP-ZFL-03	Nov. 12, 2014	Nov. 11, 2015
Trilog Broadband Antenna SCHWARZBECK	VULB 9168	9168-360	Feb. 06, 2015	Feb. 05, 2016
RF Cable	8D-FB	CHGCAB-001 -1 CHGCAB-001 -2	Oct. 04, 2014	Oct. 03, 2015
	RF-141	CHGCAB-004	Oct. 04, 2014	Oct. 03, 2015
Horn_Antenna AISI	AIH.8018	000032009111 0	Feb. 09, 2015	Feb. 08, 2016
Pre-Amplifier Agilent	8449B	3008A02578	June 23, 2015	June 22, 2016
RF Cable	NA	131205 131216 131217 SNMY23684/ 4	Jan. 16, 2015	Jan. 15, 2016
Spectrum Analyzer R&S	FSV40	100964	June 26, 2015	June 25, 2016
Pre-Amplifier SPACEK LABS	SLKKa-48-6	9K16	Dec. 12, 2014	Dec. 11, 2015
Horn_Antenna SCHWARZBECK	BBHA 9170	9170-424	Feb. 05, 2015	Feb. 04, 2016
RF Cable	NA	329751/4 RF104-204	Dec. 11, 2014	Dec. 10, 2015
Software	ADT_Radiated _V8.7.07	NA	NA	NA
Antenna Tower & Turn Table Ct	NA	NA	NA	NA
Spectrum Analyzer R&S	FSP40	100060	May 08, 2015	May 07, 2016
Power Meter Anritsu	ML2495A	1014008	Apr. 28, 2015	Apr. 27, 2016
Power Sensor Anritsu	MA2411B	0917122	Apr. 28, 2015	Apr. 27, 2016

Note:

1. The calibration interval of the above test instruments is 12 months and the calibrations are traceable to NML/ROC and NIST/USA.
2. The test was performed in 966 Chamber No. G.
3. The FCC Site Registration No. is 966073.
4. The VCCI Site Registration No. is G-137.
5. The CANADA Site Registration No. is IC 7450H-2.
6. Tested Date: Aug. 27, 2015 to Sep. 02, 2015

4.1.3 Test Procedures

- a. The EUT was placed on the top of a rotating table 0.8 meters (for below 1GHz) / 1.5 meters (for above 1GHz) above the ground at 3 meter chamber room for test. The table was rotated 360 degrees to determine the position of the highest radiation.
- b. The EUT was set 3 meters away from the interference-receiving antenna, which was mounted on the top of a variable-height antenna tower.
- c. The height of antenna is varied from one meter to four meters above the ground to determine the maximum value of the field strength. Both horizontal and vertical polarizations of the antenna are set to make the measurement.
- d. For each suspected emission, the EUT was arranged to its worst case and then the antenna was tuned to heights from 1 meter to 4 meters and the rotatable table was turned from 0 degrees to 360 degrees to find the maximum reading.
- e. The test-receiver system was set to quasi-peak detect function and specified bandwidth with maximum hold mode when the test frequency is below 1 GHz.
- f. The test-receiver system was set to peak and average detect function and specified bandwidth with maximum hold mode when the test frequency is above 1 GHz. If the peak reading value also meets average limit, measurement with the average detector is unnecessary.

Note:

1. The resolution bandwidth and video bandwidth of test receiver/spectrum analyzer is 120kHz for Quasi-peak detection (QP) at frequency below 1GHz.
2. The resolution bandwidth of test receiver/spectrum analyzer is 1 MHz and the video bandwidth is 3 MHz for Peak detection (PK) at frequency above 1GHz.
3. The resolution bandwidth of test receiver/spectrum analyzer is 1MHz and the video bandwidth is 3MHz for RMS Average (Duty cycle < 98%) for Average detection (AV) at frequency above 1GHz, then the measurement results was added to a correction factor ($10 \log(1/\text{duty cycle})$).
4. The resolution bandwidth of test receiver/spectrum analyzer is 1MHz and the video bandwidth is 10Hz (Duty cycle $\geq 98\%$) for Average detection (AV) at frequency above 1GHz.
5. All modes of operation were investigated and the worst-case emissions are reported.

4.1.4 Deviation from Test Standard

No deviation.

4.1.5 Test Setup

<Frequency Range below 1GHz>

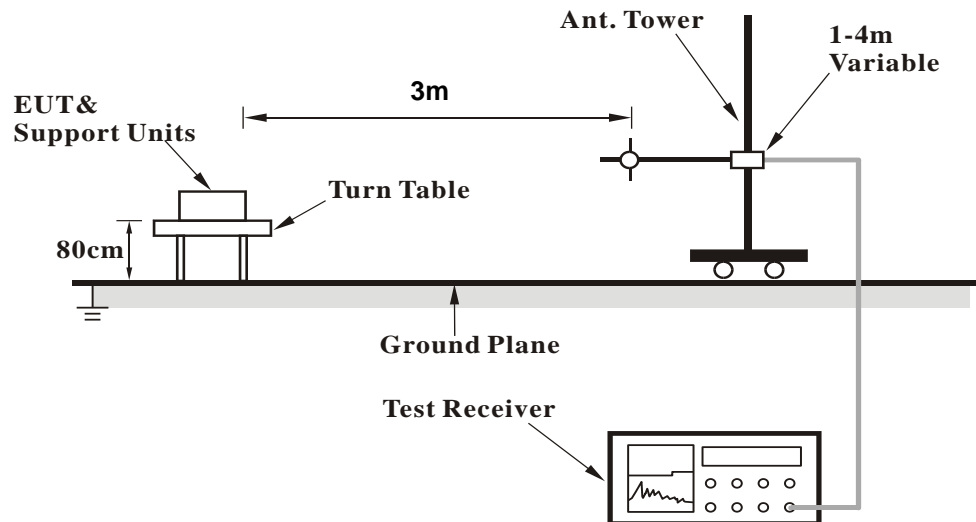

<Frequency Range above 1GHz>

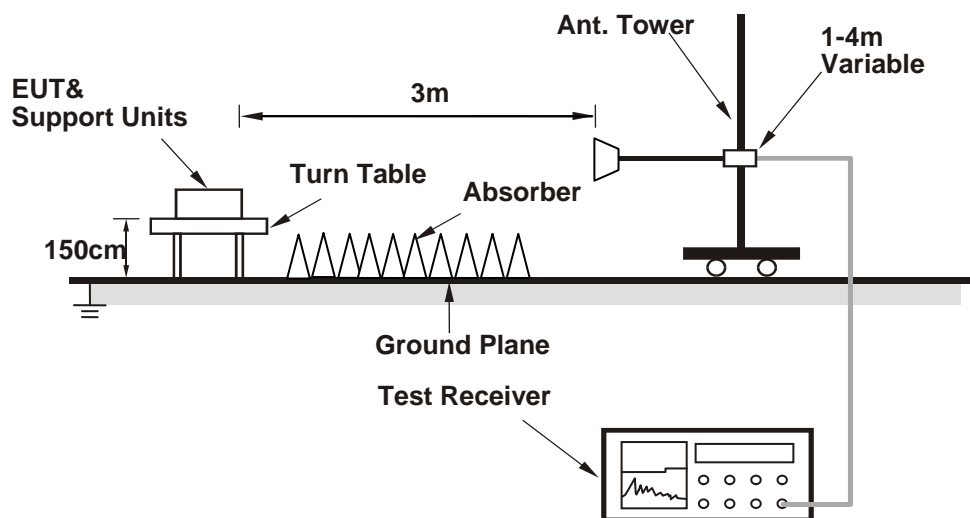

For the actual test configuration, please refer to the attached file (Test Setup Photo).

4.1.6 EUT Operating Conditions

1. Connect the EUT with the support unit E (Notebook Computer) which is placed on remote site.
2. Controlling software (command.txt) has been activated to set the EUT on specific status.

4.1.7 Test Results

Above 1GHz Data

802.11b

CHANNEL	TX Channel 1	DETECTOR FUNCTION	Peak (PK)
FREQUENCY RANGE	1GHz ~ 25GHz		Average (AV)

ANTENNA POLARITY & TEST DISTANCE: HORIZONTAL AT 3 M

NO.	FREQ. (MHz)	EMISSION LEVEL (dBuV/m)	LIMIT (dBuV/m)	MARGIN (dB)	ANTENNA HEIGHT (m)	TABLE ANGLE (Degree)	RAW VALUE (dBuV)	CORRECTION FACTOR (dB/m)
1	2390.00	59.6 PK	74.0	-14.4	1.51 H	192	25.20	34.40
2	2390.00	53.8 AV	54.0	-0.2	1.51 H	192	19.40	34.40
3	*2412.00	110.3 PK			1.52 H	182	75.82	34.48
4	*2412.00	108.3 AV			1.52 H	182	73.82	34.48
5	4824.00	46.9 PK	74.0	-27.1	1.31 H	205	4.18	42.72
6	4824.00	36.1 AV	54.0	-17.9	1.31 H	205	-6.62	42.72

ANTENNA POLARITY & TEST DISTANCE: VERTICAL AT 3 M

NO.	FREQ. (MHz)	EMISSION LEVEL (dBuV/m)	LIMIT (dBuV/m)	MARGIN (dB)	ANTENNA HEIGHT (m)	TABLE ANGLE (Degree)	RAW VALUE (dBuV)	CORRECTION FACTOR (dB/m)
1	2390.00	52.0 PK	74.0	-22.0	1.62 V	235	17.60	34.40
2	2390.00	44.7 AV	54.0	-9.3	1.62 V	235	10.30	34.40
3	*2412.00	102.2 PK			1.60 V	234	67.72	34.48
4	*2412.00	99.4 AV			1.60 V	234	64.92	34.48
5	4824.00	48.7 PK	74.0	-25.3	1.29 V	203	5.98	42.72
6	4824.00	37.2 AV	54.0	-16.8	1.29 V	203	-5.52	42.72

REMARKS:

1. Emission Level(dBuV/m) = Raw Value(dBuV) + Correction Factor(dB/m)
2. Correction Factor(dB/m) = Antenna Factor(dB/m) + Cable Factor(dB) – Pre-Amplifier Factor(dB)
3. The other emission levels were very low against the limit.
4. Margin value = Emission Level – Limit value
5. " * ": Fundamental frequency.

CHANNEL	TX Channel 6	DETECTOR FUNCTION	Peak (PK)
FREQUENCY RANGE	1GHz ~ 25GHz		Average (AV)

ANTENNA POLARITY & TEST DISTANCE: HORIZONTAL AT 3 M

NO.	FREQ. (MHz)	EMISSION LEVEL (dBuV/m)	LIMIT (dBuV/m)	MARGIN (dB)	ANTENNA HEIGHT (m)	TABLE ANGLE (Degree)	RAW VALUE (dBuV)	CORRECTION FACTOR (dB/m)
1	2390.00	58.2 PK	74.0	-15.8	1.28 H	185	23.80	34.40
2	2390.00	53.7 AV	54.0	-0.3	1.28 H	185	19.30	34.40
3	*2437.00	112.9 PK			1.29 H	196	78.32	34.58
4	*2437.00	111.0 AV			1.29 H	196	76.42	34.58
5	2483.50	54.6 PK	74.0	-19.4	1.28 H	196	19.81	34.79
6	2483.50	47.0 AV	54.0	-7.0	1.28 H	196	12.21	34.79
7	4874.00	47.6 PK	74.0	-26.4	1.32 H	211	4.76	42.84
8	4874.00	36.8 AV	54.0	-17.2	1.32 H	211	-6.04	42.84
9	7311.00	58.1 PK	74.0	-15.9	1.34 H	197	7.69	50.41
10	7311.00	45.0 AV	54.0	-9.0	1.34 H	197	-5.41	50.41

ANTENNA POLARITY & TEST DISTANCE: VERTICAL AT 3 M

NO.	FREQ. (MHz)	EMISSION LEVEL (dBuV/m)	LIMIT (dBuV/m)	MARGIN (dB)	ANTENNA HEIGHT (m)	TABLE ANGLE (Degree)	RAW VALUE (dBuV)	CORRECTION FACTOR (dB/m)
1	2390.00	45.6 PK	74.0	-28.4	1.49 V	219	11.20	34.40
2	2390.00	44.8 AV	54.0	-9.2	1.49 V	219	10.40	34.40
3	*2437.00	105.8 PK			1.43 V	204	71.22	34.58
4	*2437.00	102.4 AV			1.43 V	204	67.82	34.58
5	2483.50	51.6 PK	74.0	-22.4	1.45 V	216	16.81	34.79
6	2483.50	42.3 AV	54.0	-11.7	1.45 V	216	7.51	34.79
7	4874.00	48.9 PK	74.0	-25.1	1.32 V	166	6.06	42.84
8	4874.00	37.6 AV	54.0	-16.4	1.32 V	166	-5.24	42.84
9	7311.00	52.4 PK	74.0	-21.6	1.33 V	178	1.99	50.41
10	7311.00	43.8 AV	54.0	-10.2	1.33 V	178	-6.61	50.41

REMARKS:

1. Emission Level(dBuV/m) = Raw Value(dBuV) + Correction Factor(dB/m)
2. Correction Factor(dB/m) = Antenna Factor(dB/m) + Cable Factor(dB) – Pre-Amplifier Factor(dB)
3. The other emission levels were very low against the limit.
4. Margin value = Emission Level – Limit value
5. " * ": Fundamental frequency.

CHANNEL	TX Channel 11	DETECTOR FUNCTION	Peak (PK)
FREQUENCY RANGE	1GHz ~ 25GHz		Average (AV)

ANTENNA POLARITY & TEST DISTANCE: HORIZONTAL AT 3 M

NO.	FREQ. (MHz)	EMISSION LEVEL (dBuV/m)	LIMIT (dBuV/m)	MARGIN (dB)	ANTENNA HEIGHT (m)	TABLE ANGLE (Degree)	RAW VALUE (dBuV)	CORRECTION FACTOR (dB/m)
1	*2462.00	111.0 PK			1.49 H	186	76.30	34.70
2	*2462.00	108.8 AV			1.49 H	186	74.10	34.70
3	2483.50	58.0 PK	74.0	-16.0	1.51 H	200	23.21	34.79
4	2483.50	53.5 AV	54.0	-0.5	1.51 H	200	18.71	34.79
5	4924.00	47.3 PK	74.0	-26.7	1.37 H	229	4.33	42.97
6	4924.00	36.8 AV	54.0	-17.2	1.37 H	229	-6.17	42.97
7	7386.00	59.0 PK	74.0	-15.0	1.24 H	193	8.41	50.59
8	7386.00	46.0 AV	54.0	-8.0	1.24 H	193	-4.59	50.59

ANTENNA POLARITY & TEST DISTANCE: VERTICAL AT 3 M

NO.	FREQ. (MHz)	EMISSION LEVEL (dBuV/m)	LIMIT (dBuV/m)	MARGIN (dB)	ANTENNA HEIGHT (m)	TABLE ANGLE (Degree)	RAW VALUE (dBuV)	CORRECTION FACTOR (dB/m)
1	*2462.00	103.3 PK			1.54 V	207	68.60	34.70
2	*2462.00	100.6 AV			1.54 V	207	65.90	34.70
3	2483.50	51.0 PK	74.0	-23.0	1.45 V	203	16.21	34.79
4	2483.50	44.8 AV	54.0	-9.2	1.45 V	203	10.01	34.79
5	4924.00	47.4 PK	74.0	-26.6	1.25 V	201	4.43	42.97
6	4924.00	36.1 AV	54.0	-17.9	1.25 V	201	-6.87	42.97
7	7386.00	51.2 PK	74.0	-22.8	1.23 V	201	0.61	50.59
8	7386.00	42.7 AV	54.0	-11.3	1.23 V	201	-7.89	50.59

REMARKS:

1. Emission Level(dBuV/m) = Raw Value(dBuV) + Correction Factor(dB/m)
2. Correction Factor(dB/m) = Antenna Factor(dB/m) + Cable Factor(dB) – Pre-Amplifier Factor(dB)
3. The other emission levels were very low against the limit.
4. Margin value = Emission Level – Limit value
5. " * ": Fundamental frequency.



802.11g

CHANNEL	TX Channel 1	DETECTOR FUNCTION	Peak (PK)
FREQUENCY RANGE	1GHz ~ 25GHz		Average (AV)

ANTENNA POLARITY & TEST DISTANCE: HORIZONTAL AT 3 M

NO.	FREQ. (MHz)	EMISSION LEVEL (dBuV/m)	LIMIT (dBuV/m)	MARGIN (dB)	ANTENNA HEIGHT (m)	TABLE ANGLE (Degree)	RAW VALUE (dBuV)	CORRECTION FACTOR (dB/m)
1	2390.00	72.5 PK	74.0	-1.5	1.52 H	192	38.10	34.40
2	2390.00	53.8 AV	54.0	-0.2	1.52 H	192	19.40	34.40
3	*2412.00	110.9 PK			1.52 H	192	76.42	34.48
4	*2412.00	101.7 AV			1.52 H	192	67.22	34.48
5	4824.00	47.0 PK	74.0	-27.0	1.33 H	194	4.28	42.72
6	4824.00	36.1 AV	54.0	-17.9	1.33 H	194	-6.62	42.72

ANTENNA POLARITY & TEST DISTANCE: VERTICAL AT 3 M

NO.	FREQ. (MHz)	EMISSION LEVEL (dBuV/m)	LIMIT (dBuV/m)	MARGIN (dB)	ANTENNA HEIGHT (m)	TABLE ANGLE (Degree)	RAW VALUE (dBuV)	CORRECTION FACTOR (dB/m)
1	2390.00	59.8 PK	74.0	-14.2	1.36 V	247	25.40	34.40
2	2390.00	44.5 AV	54.0	-9.5	1.36 V	247	10.10	34.40
3	*2412.00	101.8 PK			1.36 V	247	67.32	34.48
4	*2412.00	92.1 AV			1.36 V	247	57.62	34.48
5	4824.00	47.7 PK	74.0	-26.3	1.26 V	205	4.98	42.72
6	4824.00	36.5 AV	54.0	-17.5	1.26 V	205	-6.22	42.72

REMARKS:

1. Emission Level(dBuV/m) = Raw Value(dBuV) + Correction Factor(dB/m)
2. Correction Factor(dB/m) = Antenna Factor(dB/m) + Cable Factor(dB) – Pre-Amplifier Factor(dB)
3. The other emission levels were very low against the limit.
4. Margin value = Emission Level – Limit value
5. " * ": Fundamental frequency.



CHANNEL	TX Channel 6	DETECTOR FUNCTION	Peak (PK)
FREQUENCY RANGE	1GHz ~ 25GHz		Average (AV)

ANTENNA POLARITY & TEST DISTANCE: HORIZONTAL AT 3 M

NO.	FREQ. (MHz)	EMISSION LEVEL (dBuV/m)	LIMIT (dBuV/m)	MARGIN (dB)	ANTENNA HEIGHT (m)	TABLE ANGLE (Degree)	RAW VALUE (dBuV)	CORRECTION FACTOR (dB/m)
1	2390.00	65.6 PK	74.0	-8.4	1.46 H	188	31.20	34.40
2	2390.00	47.3 AV	54.0	-6.7	1.46 H	188	12.90	34.40
3	*2437.00	115.7 PK			1.46 H	188	81.12	34.58
4	*2437.00	106.5 AV			1.46 H	188	71.92	34.58
5	2483.50	64.1 PK	74.0	-9.9	1.46 H	188	29.31	34.79
6	2483.50	46.4 AV	54.0	-7.6	1.46 H	188	11.61	34.79
7	4874.00	47.4 PK	74.0	-26.6	1.30 H	211	4.56	42.84
8	4874.00	36.8 AV	54.0	-17.2	1.30 H	211	-6.04	42.84
9	7311.00	58.2 PK	74.0	-15.8	1.27 H	202	7.79	50.41
10	7311.00	45.0 AV	54.0	-9.0	1.27 H	202	-5.41	50.41

ANTENNA POLARITY & TEST DISTANCE: VERTICAL AT 3 M

NO.	FREQ. (MHz)	EMISSION LEVEL (dBuV/m)	LIMIT (dBuV/m)	MARGIN (dB)	ANTENNA HEIGHT (m)	TABLE ANGLE (Degree)	RAW VALUE (dBuV)	CORRECTION FACTOR (dB/m)
1	2390.00	44.3 PK	74.0	-29.7	1.50 V	207	9.90	34.40
2	2390.00	43.8 AV	54.0	-10.2	1.50 V	207	9.40	34.40
3	*2437.00	106.4 PK			1.50 V	207	71.82	34.58
4	*2437.00	96.7 AV			1.50 V	207	62.12	34.58
5	2483.50	51.5 PK	74.0	-22.5	1.50 V	207	16.71	34.79
6	2483.50	42.3 AV	54.0	-11.7	1.50 V	207	7.51	34.79
7	4874.00	48.8 PK	74.0	-25.2	1.30 V	181	5.96	42.84
8	4874.00	37.1 AV	54.0	-16.9	1.30 V	181	-5.74	42.84
9	7311.00	52.2 PK	74.0	-21.8	1.34 V	193	1.79	50.41
10	7311.00	43.5 AV	54.0	-10.5	1.34 V	193	-6.91	50.41

REMARKS:

1. Emission Level(dBuV/m) = Raw Value(dBuV) + Correction Factor(dB/m)
2. Correction Factor(dB/m) = Antenna Factor(dB/m) + Cable Factor(dB) – Pre-Amplifier Factor(dB)
3. The other emission levels were very low against the limit.
4. Margin value = Emission Level – Limit value
5. " * ": Fundamental frequency.



CHANNEL	TX Channel 11	DETECTOR FUNCTION	Peak (PK)
FREQUENCY RANGE	1GHz ~ 25GHz		Average (AV)

ANTENNA POLARITY & TEST DISTANCE: HORIZONTAL AT 3 M

NO.	FREQ. (MHz)	EMISSION LEVEL (dBuV/m)	LIMIT (dBuV/m)	MARGIN (dB)	ANTENNA HEIGHT (m)	TABLE ANGLE (Degree)	RAW VALUE (dBuV)	CORRECTION FACTOR (dB/m)
1	*2462.00	109.1 PK			1.52 H	194	74.40	34.70
2	*2462.00	100.4 AV			1.52 H	194	65.70	34.70
3	2483.50	73.8 PK	74.0	-0.2	1.52 H	194	39.01	34.79
4	2483.50	53.2 AV	54.0	-0.8	1.52 H	194	18.41	34.79
5	4924.00	47.2 PK	74.0	-26.8	1.27 H	229	4.23	42.97
6	4924.00	36.7 AV	54.0	-17.3	1.27 H	229	-6.27	42.97
7	7386.00	58.7 PK	74.0	-15.3	1.23 H	215	8.11	50.59
8	7386.00	45.7 AV	54.0	-8.3	1.23 H	215	-4.89	50.59

ANTENNA POLARITY & TEST DISTANCE: VERTICAL AT 3 M

NO.	FREQ. (MHz)	EMISSION LEVEL (dBuV/m)	LIMIT (dBuV/m)	MARGIN (dB)	ANTENNA HEIGHT (m)	TABLE ANGLE (Degree)	RAW VALUE (dBuV)	CORRECTION FACTOR (dB/m)
1	*2462.00	100.1 PK			1.36 V	222	65.40	34.70
2	*2462.00	90.9 AV			1.36 V	222	56.20	34.70
3	2483.50	60.9 PK	74.0	-13.1	1.36 V	222	26.11	34.79
4	2483.50	43.9 AV	54.0	-10.1	1.36 V	222	9.11	34.79
5	4924.00	47.9 PK	74.0	-26.1	1.27 V	201	4.93	42.97
6	4924.00	36.4 AV	54.0	-17.6	1.27 V	201	-6.57	42.97
7	7386.00	51.9 PK	74.0	-22.1	1.26 V	179	1.31	50.59
8	7386.00	43.5 AV	54.0	-10.5	1.26 V	179	-7.09	50.59

REMARKS:

1. Emission Level(dBuV/m) = Raw Value(dBuV) + Correction Factor(dB/m)
2. Correction Factor(dB/m) = Antenna Factor(dB/m) + Cable Factor(dB) – Pre-Amplifier Factor(dB)
3. The other emission levels were very low against the limit.
4. Margin value = Emission Level – Limit value
5. " * ": Fundamental frequency.



802.11n (HT20)

CHANNEL	TX Channel 1	DETECTOR FUNCTION	Peak (PK)
FREQUENCY RANGE	1GHz ~ 25GHz		Average (AV)

ANTENNA POLARITY & TEST DISTANCE: HORIZONTAL AT 3 M

NO.	FREQ. (MHz)	EMISSION LEVEL (dBuV/m)	LIMIT (dBuV/m)	MARGIN (dB)	ANTENNA HEIGHT (m)	TABLE ANGLE (Degree)	RAW VALUE (dBuV)	CORRECTION FACTOR (dB/m)
1	2390.00	71.3 PK	74.0	-2.7	1.77 H	139	36.90	34.40
2	2390.00	53.7 AV	54.0	-0.3	1.77 H	139	19.30	34.40
3	*2412.00	109.5 PK			1.77 H	139	75.02	34.48
4	*2412.00	100.5 AV			1.77 H	139	66.02	34.48
5	4824.00	47.3 PK	74.0	-26.7	1.30 H	221	4.58	42.72
6	4824.00	36.8 AV	54.0	-17.2	1.30 H	221	-5.92	42.72

ANTENNA POLARITY & TEST DISTANCE: VERTICAL AT 3 M

NO.	FREQ. (MHz)	EMISSION LEVEL (dBuV/m)	LIMIT (dBuV/m)	MARGIN (dB)	ANTENNA HEIGHT (m)	TABLE ANGLE (Degree)	RAW VALUE (dBuV)	CORRECTION FACTOR (dB/m)
1	2390.00	65.8 PK	74.0	-8.2	1.33 V	128	31.40	34.40
2	2390.00	45.4 AV	54.0	-8.6	1.33 V	128	11.00	34.40
3	*2412.00	102.0 PK			1.33 V	128	67.52	34.48
4	*2412.00	92.0 AV			1.33 V	128	57.52	34.48
5	4824.00	47.7 PK	74.0	-26.3	1.22 V	201	4.98	42.72
6	4824.00	36.7 AV	54.0	-17.3	1.22 V	201	-6.02	42.72

REMARKS:

1. Emission Level(dBuV/m) = Raw Value(dBuV) + Correction Factor(dB/m)
2. Correction Factor(dB/m) = Antenna Factor(dB/m) + Cable Factor(dB) – Pre-Amplifier Factor(dB)
3. The other emission levels were very low against the limit.
4. Margin value = Emission Level – Limit value
5. " * ": Fundamental frequency.

CHANNEL	TX Channel 6	DETECTOR FUNCTION	Peak (PK)
FREQUENCY RANGE	1GHz ~ 25GHz		Average (AV)

ANTENNA POLARITY & TEST DISTANCE: HORIZONTAL AT 3 M

NO.	FREQ. (MHz)	EMISSION LEVEL (dBuV/m)	LIMIT (dBuV/m)	MARGIN (dB)	ANTENNA HEIGHT (m)	TABLE ANGLE (Degree)	RAW VALUE (dBuV)	CORRECTION FACTOR (dB/m)
1	2390.00	73.6 PK	74.0	-0.4	1.43 H	203	39.20	34.40
2	2390.00	52.2 AV	54.0	-1.8	1.43 H	203	17.80	34.40
3	*2437.00	112.5 PK			1.33 H	128	77.92	34.58
4	*2437.00	104.0 AV			1.33 H	128	69.42	34.58
5	2483.50	70.9 PK	74.0	-3.1	1.45 H	185	36.11	34.79
6	2483.50	47.6 AV	54.0	-6.4	1.45 H	185	12.81	34.79
7	4874.00	47.1 PK	74.0	-26.9	1.27 H	197	4.26	42.84
8	4874.00	36.6 AV	54.0	-17.4	1.27 H	197	-6.24	42.84
9	7311.00	58.3 PK	74.0	-15.7	1.26 H	197	7.89	50.41
10	7311.00	45.3 AV	54.0	-8.7	1.26 H	197	-5.11	50.41

ANTENNA POLARITY & TEST DISTANCE: VERTICAL AT 3 M

NO.	FREQ. (MHz)	EMISSION LEVEL (dBuV/m)	LIMIT (dBuV/m)	MARGIN (dB)	ANTENNA HEIGHT (m)	TABLE ANGLE (Degree)	RAW VALUE (dBuV)	CORRECTION FACTOR (dB/m)
1	2390.00	44.3 PK	74.0	-29.7	1.49 V	218	9.90	34.40
2	2390.00	43.7 AV	54.0	-10.3	1.49 V	218	9.30	34.40
3	*2437.00	105.3 PK			1.49 V	218	70.72	34.58
4	*2437.00	96.0 AV			1.49 V	218	61.42	34.58
5	2483.50	51.5 PK	74.0	-22.5	1.49 V	218	16.71	34.79
6	2483.50	42.6 AV	54.0	-11.4	1.49 V	218	7.81	34.79
7	4874.00	48.6 PK	74.0	-25.4	1.34 V	188	5.76	42.84
8	4874.00	36.7 AV	54.0	-17.3	1.34 V	188	-6.14	42.84
9	7311.00	52.2 PK	74.0	-21.8	1.34 V	188	1.79	50.41
10	7311.00	43.5 AV	54.0	-10.5	1.34 V	188	-6.91	50.41

REMARKS:

1. Emission Level(dBuV/m) = Raw Value(dBuV) + Correction Factor(dB/m)
2. Correction Factor(dB/m) = Antenna Factor(dB/m) + Cable Factor(dB) – Pre-Amplifier Factor(dB)
3. The other emission levels were very low against the limit.
4. Margin value = Emission Level – Limit value
5. " * ": Fundamental frequency.



CHANNEL	TX Channel 11	DETECTOR FUNCTION	Peak (PK)
FREQUENCY RANGE	1GHz ~ 25GHz		Average (AV)

ANTENNA POLARITY & TEST DISTANCE: HORIZONTAL AT 3 M

NO.	FREQ. (MHz)	EMISSION LEVEL (dBuV/m)	LIMIT (dBuV/m)	MARGIN (dB)	ANTENNA HEIGHT (m)	TABLE ANGLE (Degree)	RAW VALUE (dBuV)	CORRECTION FACTOR (dB/m)
1	*2462.00	108.4 PK			1.54 H	152	73.70	34.70
2	*2462.00	99.8 AV			1.54 H	152	65.10	34.70
3	2483.50	70.3 PK	74.0	-3.7	1.54 H	152	35.51	34.79
4	2483.50	53.8 AV	54.0	-0.2	1.54 H	152	19.01	34.79
5	4924.00	47.1 PK	74.0	-26.9	1.24 H	207	4.13	42.97
6	4924.00	36.6 AV	54.0	-17.4	1.24 H	207	-6.37	42.97
7	7386.00	59.0 PK	74.0	-15.0	1.22 H	204	8.41	50.59
8	7386.00	45.8 AV	54.0	-8.2	1.22 H	204	-4.79	50.59

ANTENNA POLARITY & TEST DISTANCE: VERTICAL AT 3 M

NO.	FREQ. (MHz)	EMISSION LEVEL (dBuV/m)	LIMIT (dBuV/m)	MARGIN (dB)	ANTENNA HEIGHT (m)	TABLE ANGLE (Degree)	RAW VALUE (dBuV)	CORRECTION FACTOR (dB/m)
1	*2462.00	101.4 PK			1.35 V	222	66.70	34.70
2	*2462.00	91.5 AV			1.35 V	222	56.80	34.70
3	2483.50	60.2 PK	74.0	-13.8	1.35 V	222	25.41	34.79
4	2483.50	43.7 AV	54.0	-10.3	1.35 V	222	8.91	34.79
5	4924.00	48.1 PK	74.0	-25.9	1.21 V	170	5.13	42.97
6	4924.00	36.7 AV	54.0	-17.3	1.21 V	170	-6.27	42.97
7	7386.00	51.6 PK	74.0	-22.4	1.21 V	170	1.01	50.59
8	7386.00	43.0 AV	54.0	-11.0	1.21 V	170	-7.59	50.59

REMARKS:

1. Emission Level(dBuV/m) = Raw Value(dBuV) + Correction Factor(dB/m)
2. Correction Factor(dB/m) = Antenna Factor(dB/m) + Cable Factor(dB) – Pre-Amplifier Factor(dB)
3. The other emission levels were very low against the limit.
4. Margin value = Emission Level – Limit value
5. " * ": Fundamental frequency.

Below 1GHz Data:

802.11g

CHANNEL	TX Channel 6	DETECTOR FUNCTION	Quasi-Peak (QP)
FREQUENCY RANGE	30MHz ~ 1GHz		

ANTENNA POLARITY & TEST DISTANCE: HORIZONTAL AT 3 M

NO.	FREQ. (MHz)	EMISSION LEVEL (dBuV/m)	LIMIT (dBuV/m)	MARGIN (dB)	ANTENNA HEIGHT (m)	TABLE ANGLE (Degree)	RAW VALUE (dBuV)	CORRECTION FACTOR (dB/m)
1	232.83	34.3 QP	46.0	-11.7	1.00 H	275	49.45	-15.17
2	367.51	38.1 QP	46.0	-7.9	1.00 H	360	48.27	-10.21
3	434.34	39.9 QP	46.0	-6.2	1.50 H	310	47.95	-8.10
4	501.18	42.1 QP	46.0	-4.0	1.50 H	333	48.85	-6.80
5	700.42	34.7 QP	46.0	-11.3	1.00 H	285	37.49	-2.77
6	959.99	41.0 QP	46.0	-5.0	1.00 H	282	39.33	1.69

ANTENNA POLARITY & TEST DISTANCE: VERTICAL AT 3 M

NO.	FREQ. (MHz)	EMISSION LEVEL (dBuV/m)	LIMIT (dBuV/m)	MARGIN (dB)	ANTENNA HEIGHT (m)	TABLE ANGLE (Degree)	RAW VALUE (dBuV)	CORRECTION FACTOR (dB/m)
1	40.04	34.2 QP	40.0	-5.8	1.00 V	308	47.72	-13.50
2	191.99	32.7 QP	43.5	-10.8	2.00 V	257	48.51	-15.79
3	432.31	36.7 QP	46.0	-9.3	1.00 V	291	44.89	-8.19
4	498.80	42.5 QP	46.0	-3.5	1.00 V	269	49.38	-6.86
5	700.46	33.4 QP	46.0	-12.6	1.00 V	267	36.18	-2.77
6	897.81	35.7 QP	46.0	-10.4	1.00 V	291	34.98	0.67

REMARKS:

1. Emission Level(dBuV/m) = Raw Value(dBuV) + Correction Factor(dB/m)
2. Correction Factor(dB/m) = Antenna Factor(dB/m) + Cable Factor(dB) – Pre-Amplifier Factor(dB)
3. The other emission levels were very low against the limit.
4. Margin value = Emission Level – Limit value

4.2 Conducted Emission Measurement

4.2.1 Limits of Conducted Emission Measurement

Frequency (MHz)	Conducted Limit (dBuV)	
	Quasi-peak	Average
0.15 - 0.5	66 - 56	56 - 46
0.50 - 5.0	56	46
5.0 - 30.0	60	50

Note: 1. The lower limit shall apply at the transition frequencies.

2. The limit decreases in line with the logarithm of the frequency in the range of 0.15 to 0.50MHz.

4.2.2 Test Instruments

DESCRIPTION & MANUFACTURER	MODEL NO.	SERIAL NO.	CALIBRATED DATE	CALIBRATED UNTIL
Test Receiver R&S	ESCS 30	100375	May 06, 2015	May 05, 2016
Line-Impedance Stabilization Network (for EUT) SCHWARZBECK	NSLK-8127	8127-522	Sep. 15, 2014	Sep. 14, 2015
Line-Impedance Stabilization Network (for Peripheral) R&S	ENV216	100072	June 11, 2015	June 10, 2016
RF Cable	5D-FB	COCCAB-001	Mar. 09, 2015	Mar. 08, 2016
50 ohms Terminator	E1-011311	09	Nov. 27, 2014	Nov. 26, 2015
50 ohms Terminator	N/A	EMC-02	Sep. 30, 2014	Sep. 29, 2015
Software BVADT	BVADT_Cond_ V7.3.7.3	NA	NA	NA

Note:

1. The calibration interval of the above test instruments are 12 months and the calibrations are traceable to NML/ROC and NIST/USA.
2. The test was performed in Shielded Room No. C.
- 3 The VCCI Con C Registration No. is C-3611.
- 4 Tested Date: Aug. 27, 2015

4.2.3 Test Procedures

- The EUT was placed 0.4 meters from the conducting wall of the shielded room with EUT being connected to the power mains through a line impedance stabilization network (LISN). Other support units were connected to the power mains through another LISN. The two LISNs provide 50 ohm/ 50uH of coupling impedance for the measuring instrument.
- Both lines of the power mains connected to the EUT were checked for maximum conducted interference.
- The frequency range from 150kHz to 30MHz was searched. Emission levels under (Limit - 20dB) was not recorded.

NOTE: The resolution bandwidth and video bandwidth of test receiver is 9kHz for quasi-peak detection (QP) and average detection (AV) at frequency 0.15MHz-30MHz.

4.2.4 Deviation from Test Standard

No deviation.

4.2.5 Test Setup

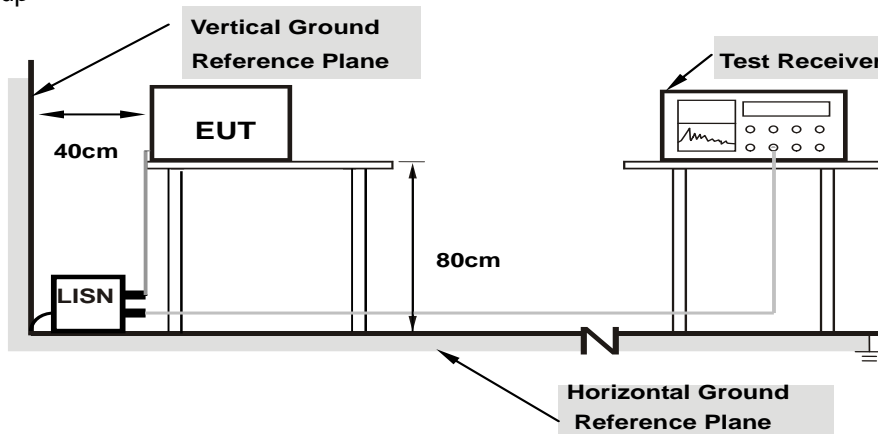

Note: 1.Support units were connected to second LISN.

For the actual test configuration, please refer to the attached file (Test Setup Photo).

4.2.6 EUT Operating Conditions

Same as 4.1.6.

4.2.7 Test Results

Phase	Line (L)	Detector Function	Quasi-Peak (QP) / Average (AV)
-------	----------	-------------------	--------------------------------

No	Frequency (MHz)	Correction Factor (dB)	Reading Value (dBuV)		Emission Level (dBuV)		Limit (dBuV)		Margin (dB)	
			Q.P.	AV.	Q.P.	AV.	Q.P.	AV.	Q.P.	AV.
1	0.18097	0.09	45.50	45.48	45.59	45.57	64.44	54.44	-18.85	-8.87
2	0.27109	0.09	34.45	28.99	34.54	29.08	61.08	51.08	-26.54	-22.00
3	1.39063	0.15	23.09	16.70	23.24	16.85	56.00	46.00	-32.76	-29.15
4	2.82262	0.19	23.15	12.74	23.34	12.93	56.00	46.00	-32.66	-33.07
5	14.56641	0.56	26.73	25.22	27.29	25.78	60.00	50.00	-32.71	-24.22
6	19.70703	0.69	29.98	25.71	30.67	26.40	60.00	50.00	-29.33	-23.60

Remarks:

1. Q.P. and AV. are abbreviations of quasi-peak and average individually.
2. The emission levels of other frequencies were very low against the limit.
3. Margin value = Emission level – Limit value
4. Correction factor = Insertion loss + Cable loss
5. Emission Level = Correction Factor + Reading Value

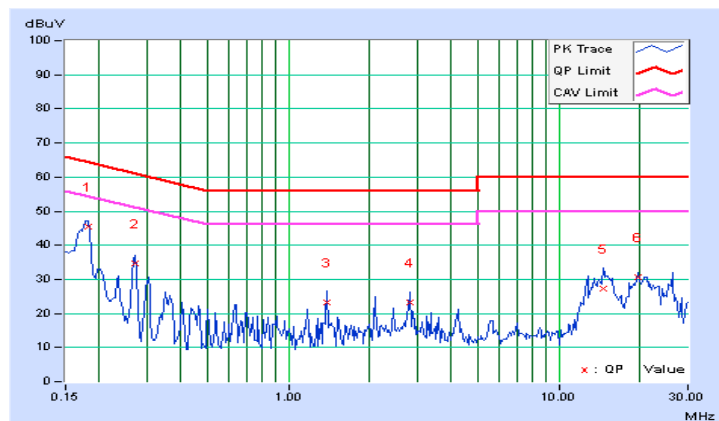

Phase	Neutral (N)	Detector Function	Quasi-Peak (QP) / Average (AV)
-------	-------------	-------------------	--------------------------------

No	Frequency (MHz)	Correction Factor (dB)	Reading Value (dBuV)		Emission Level (dBuV)		Limit (dBuV)		Margin (dB)	
			Q.P.	AV.	Q.P.	AV.	Q.P.	AV.	Q.P.	AV.
1	0.18125	0.08	47.96	47.11	48.04	47.19	64.43	54.43	-16.39	-7.24
2	0.26919	0.09	35.06	30.28	35.15	30.37	61.14	51.14	-26.00	-20.78
3	0.63828	0.11	20.98	19.21	21.09	19.32	56.00	46.00	-34.91	-26.68
4	2.08906	0.17	24.56	23.74	24.73	23.91	56.00	46.00	-31.27	-22.09
5	14.69922	0.59	27.57	22.48	28.16	23.07	60.00	50.00	-31.84	-26.93
6	21.66406	0.78	27.25	22.55	28.03	23.33	60.00	50.00	-31.97	-26.67

Remarks:

1. Q.P. and AV. are abbreviations of quasi-peak and average individually.
2. The emission levels of other frequencies were very low against the limit.
3. Margin value = Emission level – Limit value
4. Correction factor = Insertion loss + Cable loss
5. Emission Level = Correction Factor + Reading Value

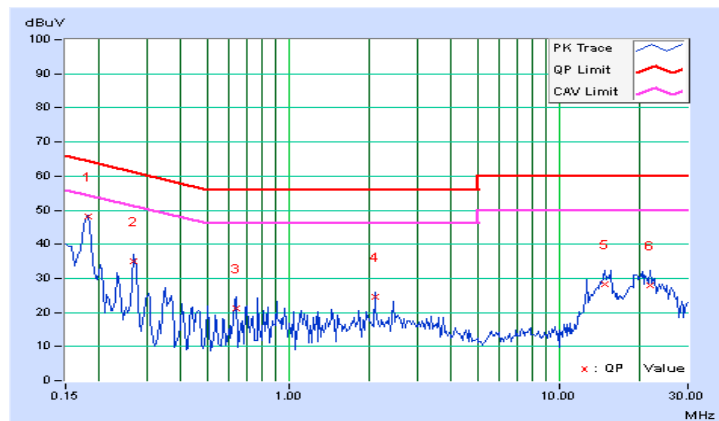

4.3 6dB Bandwidth Measurement

4.3.1 Limits of 6dB Bandwidth Measurement

The minimum of 6dB Bandwidth Measurement is 0.5 MHz.

4.3.2 Test Setup

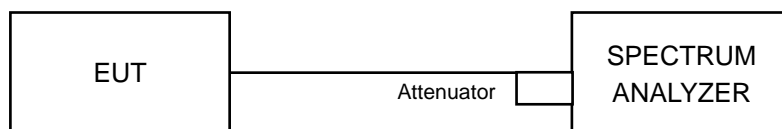

4.3.3 Test Instruments

Refer to section 4.1.2 to get information of above instrument.

4.3.4 Test Procedure

- a. Set resolution bandwidth (RBW) = 100kHz
- b. Set the video bandwidth (VBW) $\geq 3 \times$ RBW, Detector = Peak.
- c. Trace mode = max hold.
- d. Sweep = auto couple.
- e. Measure the maximum width of the emission that is constrained by the frequencies associated with the two amplitude points (upper and lower) that are attenuated by 6 dB relative to the maximum level measured in the fundamental emission

4.3.5 Deviation from Test Standard

No deviation.

4.3.6 EUT Operating Conditions

The software provided by client to enable the EUT under transmission condition continuously at lowest, middle and highest channel frequencies individually.

4.3.7 Test Result

802.11b

Channel	Frequency (MHz)	6dB Bandwidth (MHz)	Minimum Limit (MHz)	Pass / Fail
1	2412	9.74	0.5	PASS
6	2437	9.19	0.5	PASS
11	2462	8.59	0.5	PASS

802.11g

Channel	Frequency (MHz)	6dB Bandwidth (MHz)	Minimum Limit (MHz)	Pass / Fail
1	2412	15.17	0.5	PASS
6	2437	15.17	0.5	PASS
11	2462	15.19	0.5	PASS

802.11n (HT20)

Channel	Frequency (MHz)	6dB Bandwidth (MHz)	Minimum Limit (MHz)	Pass / Fail
1	2412	15.15	0.5	Pass
6	2437	15.19	0.5	Pass
11	2462	15.10	0.5	Pass



Spectrum Plot of Worst Value

802.11b – Ch11

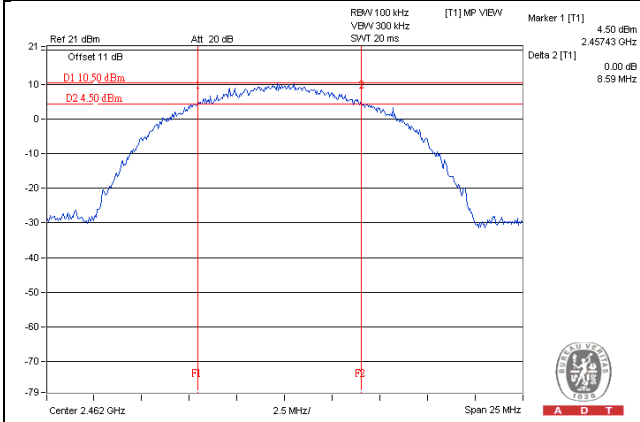

802.11g – Ch1

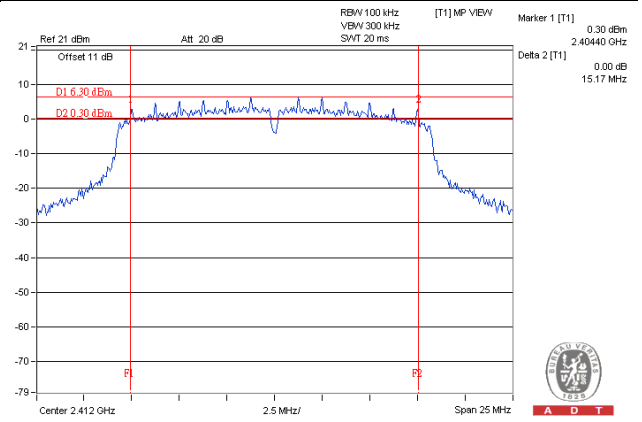

802.11n (HT20) – Ch11

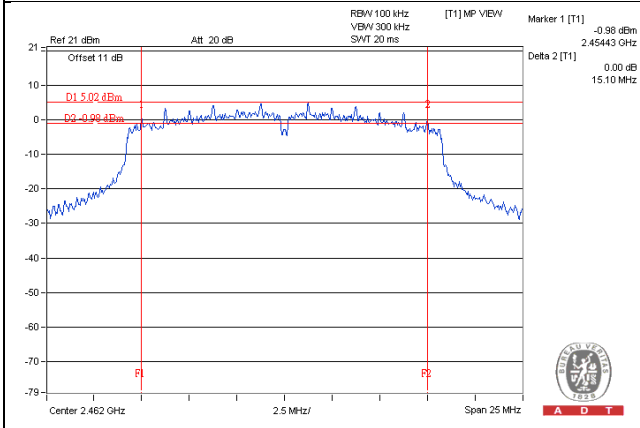

4.4 Conducted Output Power Measurement

4.4.1 Limits of Conducted Output Power Measurement

For systems using digital modulation in the 2400–2483.5 MHz bands: 1 Watt (30dBm)

4.4.2 Test Setup

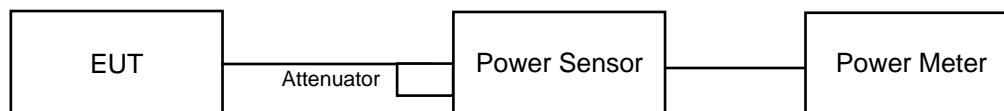

4.4.3 Test Instruments

Refer to section 4.1.2 to get information of above instrument.

4.4.4 Test Procedures

A peak / average power sensor was used on the output port of the EUT. A power meter was used to read the response of the peak / average power sensor. Record the power level.

4.4.5 Deviation from Test Standard

No deviation.

4.4.6 EUT Operating Conditions

Same as Item 4.3.6.

4.4.7 Test Results

FOR PEAK POWER

802.11b

Channel	Frequency (MHz)	Peak Power (mW)	Peak Power (dBm)	Limit (dBm)	Pass/Fail
1	2412	122.744	20.89	30	Pass
6	2437	158.489	22.00	30	Pass
11	2462	132.434	21.22	30	Pass

802.11g

Channel	Frequency (MHz)	Peak Power (mW)	Peak Power (dBm)	Limit (dBm)	Pass/Fail
1	2412	224.388	23.51	30	Pass
6	2437	210.378	23.23	30	Pass
11	2462	172.982	22.38	30	Pass

802.11n (HT20)

Channel	Frequency (MHz)	Peak Power (mW)	Peak Power (dBm)	Limit (dBm)	Pass/Fail
1	2412	151.008	21.79	30	Pass
6	2437	217.27	23.37	30	Pass
11	2462	145.211	21.62	30	Pass

FOR AVERAGE POWER

802.11b

Channel	Frequency (MHz)	Average Power (mW)	Average Power (dBm)
1	2412	82.224	19.15
6	2437	106.170	20.26
11	2462	99.541	19.98

802.11g

Channel	Frequency (MHz)	Average Power (mW)	Average Power (dBm)
1	2412	50.119	17.00
6	2437	96.383	19.84
11	2462	39.264	15.94

802.11n (HT20)

Channel	Frequency (MHz)	Average Power (mW)	Average Power (dBm)
1	2412	38.548	15.86
6	2437	77.983	18.92
11	2462	26.730	14.27

4.5 Power Spectral Density Measurement

4.5.1 Limits of Power Spectral Density Measurement

The Maximum of Power Spectral Density Measurement is 8dBm.

4.5.2 Test Setup

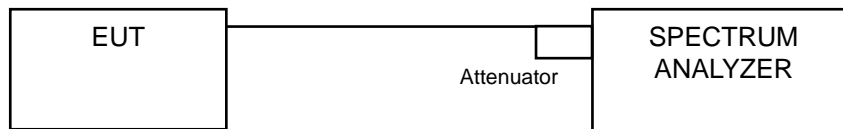

4.5.3 Test Instruments

Refer to section 4.1.2 to get information of above instrument.

4.5.4 Test Procedure

- Set analyzer center frequency to DTS channel center frequency.
- Set the span to 1.5 times the DTS bandwidth.
- Set the RBW to: $3 \text{ kHz} \leq \text{RBW} \leq 100 \text{ kHz}$.
- Set the VBW $\geq 3 \times \text{RBW}$.
- Detector = peak.
- Sweep time = auto couple.
- Trace mode = max hold.
- Allow trace to fully stabilize.
- Use the peak marker function to determine the maximum amplitude level within the RBW.

4.5.5 Deviation from Test Standard

No deviation.

4.5.6 EUT Operating Condition

Same as Item 4.3.6

4.5.7 Test Results

802.11b

Channel	Freq. (MHz)	PSD (dBm)	Limit (dBm)	Pass /Fail
1	2412	-4.16	8	Pass
6	2437	-3.03	8	Pass
11	2462	-4.46	8	Pass

802.11g

Channel	Freq. (MHz)	PSD (dBm)	Limit (dBm)	Pass /Fail
1	2412	-8.16	8	Pass
6	2437	-5.49	8	Pass
11	2462	-8.44	8	Pass

802.11n (HT20)

Channel	Freq. (MHz)	PSD (dBm)	Limit (dBm)	Pass /Fail
1	2412	-7.27	8	Pass
6	2437	-4.48	8	Pass
11	2462	-9.19	8	Pass



Spectrum Plot of Worst Value

802.11b – Ch6

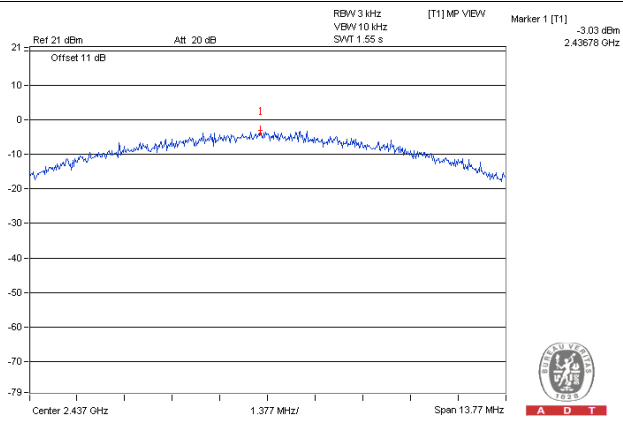

802.11g – Ch6

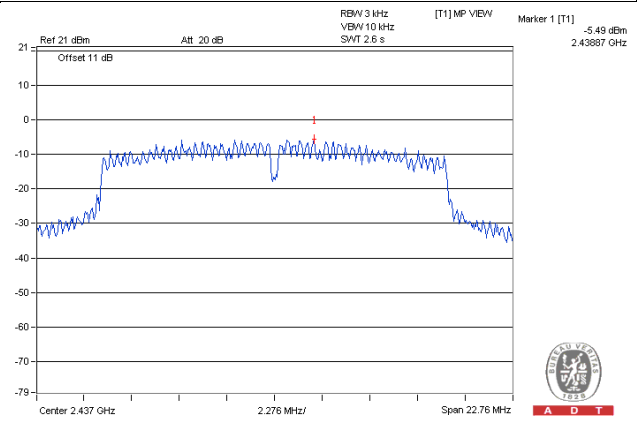

802.11n (HT20) – Ch6

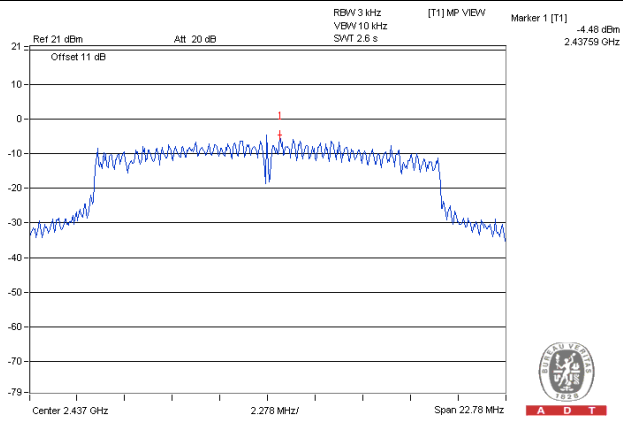

4.6 Conducted Out of Band Emission Measurement

4.6.1 Limits of Conducted Out of Band Emission Measurement

Below 20dBc of the highest emission level of operating band (in 100kHz Resolution Bandwidth).

4.6.2 Test Setup

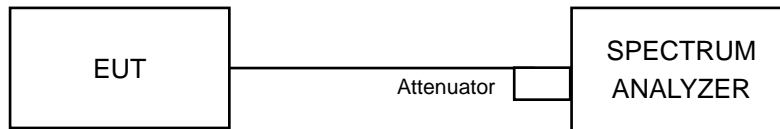

4.6.3 Test Instruments

Refer to section 4.1.2 to get information of above instrument.

4.6.4 Test Procedure

MEASUREMENT PROCEDURE REF

1. Set the RBW = 100 kHz.
2. Set the VBW \geq 300 kHz.
3. Detector = peak.
4. Sweep time = auto couple.
5. Trace mode = max hold.
6. Allow trace to fully stabilize.
7. Use the peak marker function to determine the maximum power level in any 100 kHz band segment within the fundamental EBW.

MEASUREMENT PROCEDURE OOBE

1. Set RBW = 100 kHz.
2. Set VBW \geq 300 kHz.
3. Detector = peak.
4. Sweep = auto couple.
5. Trace Mode = max hold.
6. Allow trace to fully stabilize.
7. Use the peak marker function to determine the maximum amplitude level.

4.6.5 Deviation from Test Standard

No deviation.

4.6.6 EUT Operating Condition

Same as Item 4.3.6

4.6.7 Test Results

The spectrum plots are attached on the following pages. D1 line indicates the highest level, and D2 line indicates the 20dB offset below D1. It shows compliance with the requirement.

802.11b

CH 1

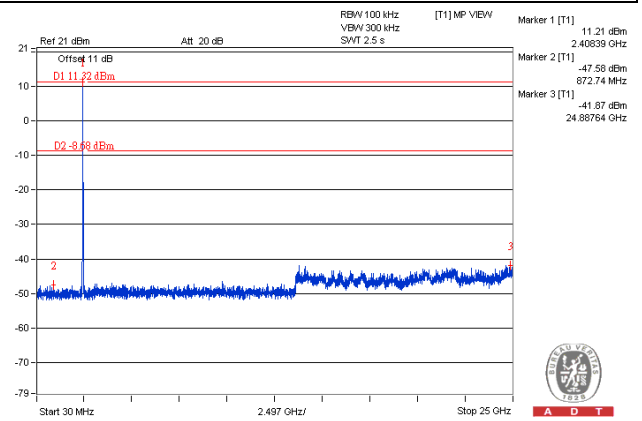
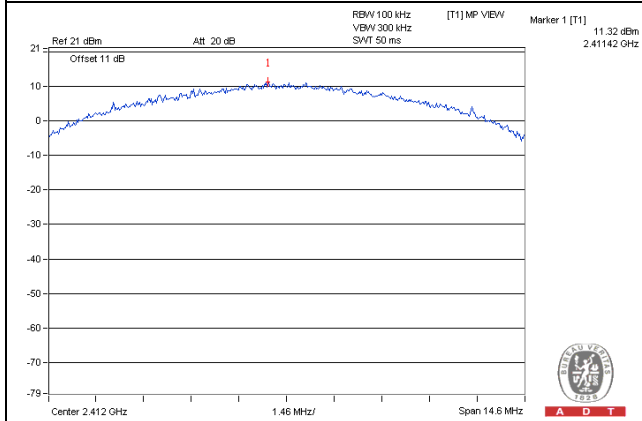

CH 6

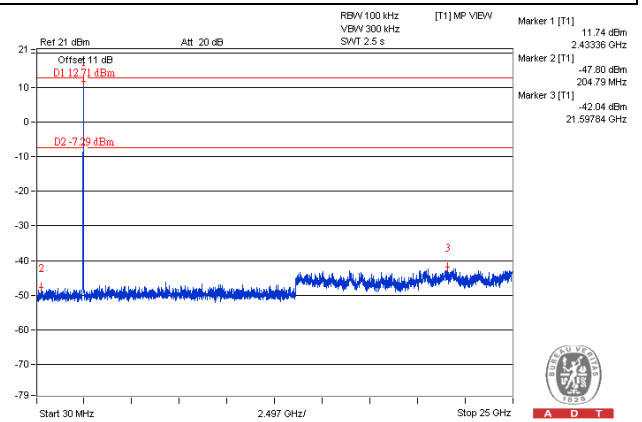
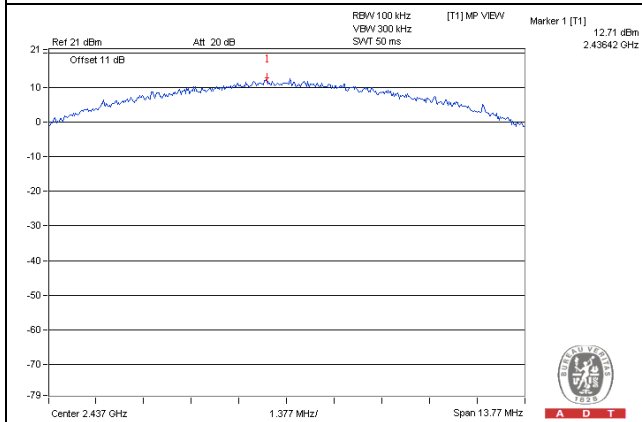

CH 11

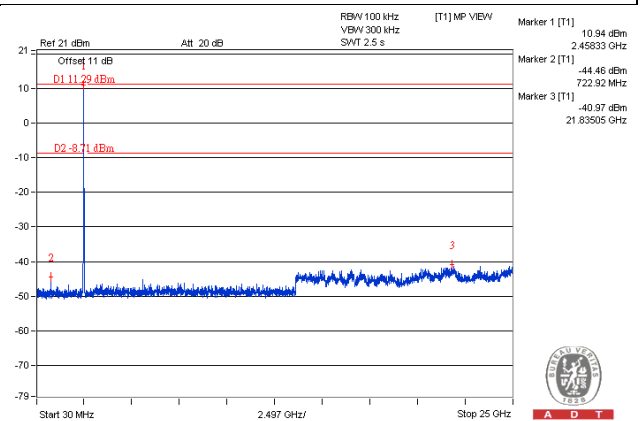
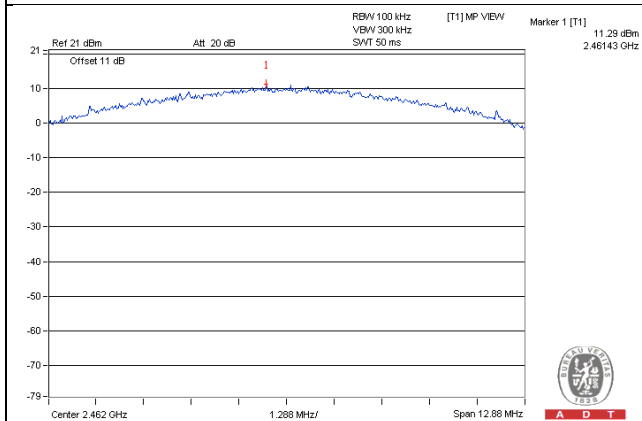

CH 1 Band edge

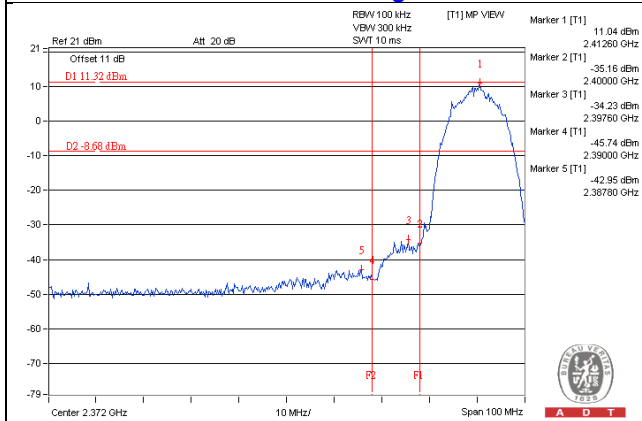

CH 11 Band edge

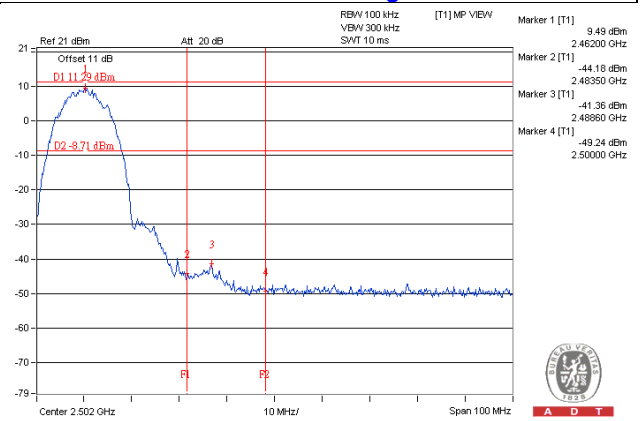

802.11g

CH 1

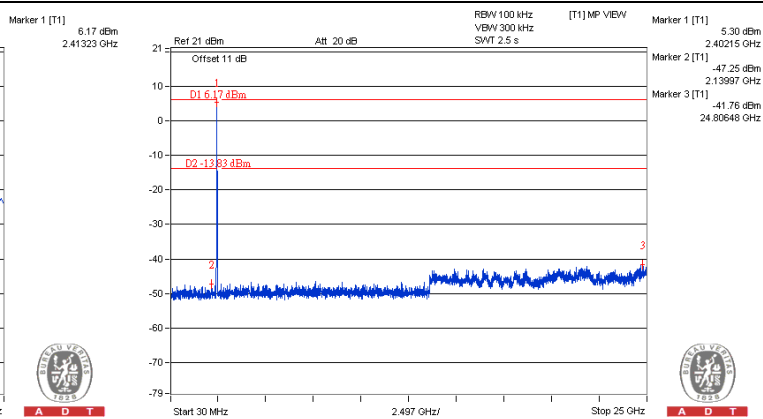
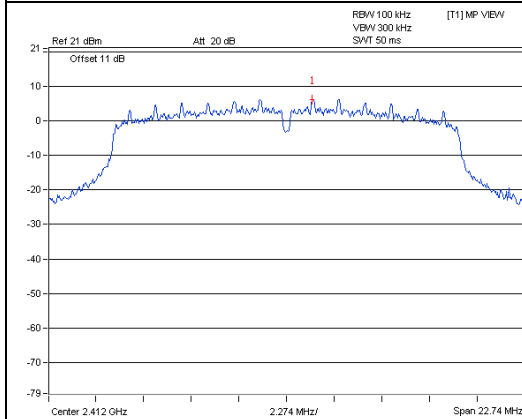

CH 6

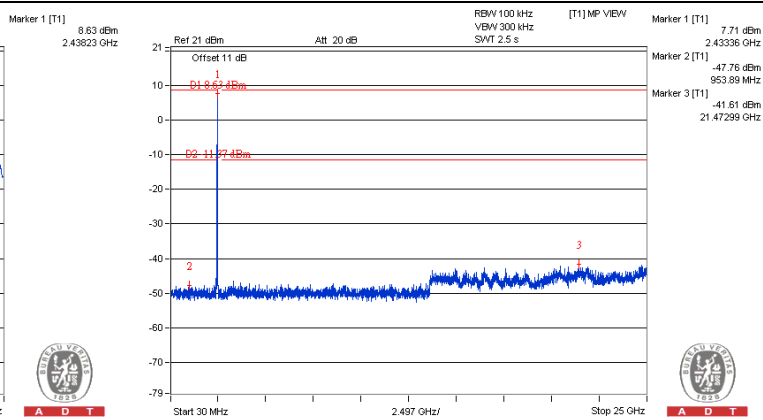
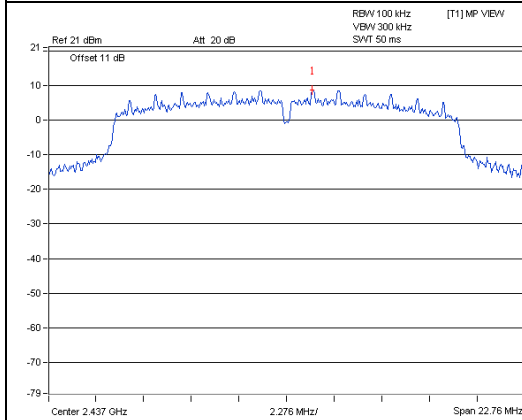

CH 11

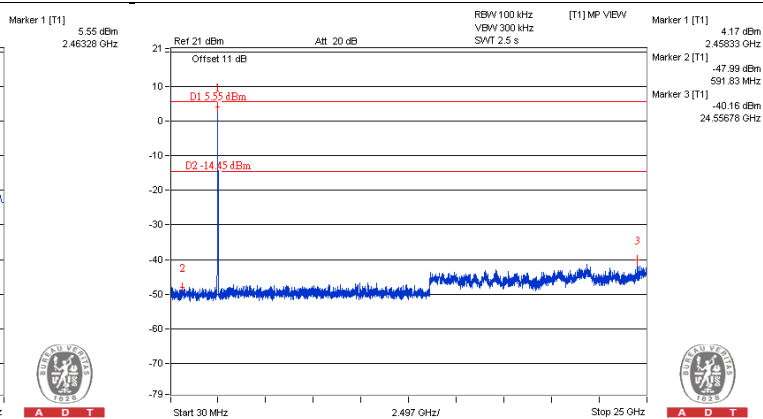
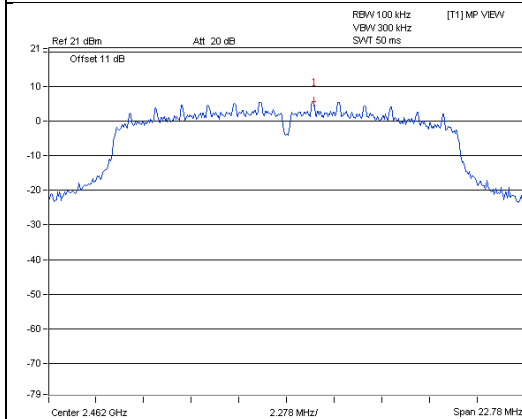

CH 1 Band edge

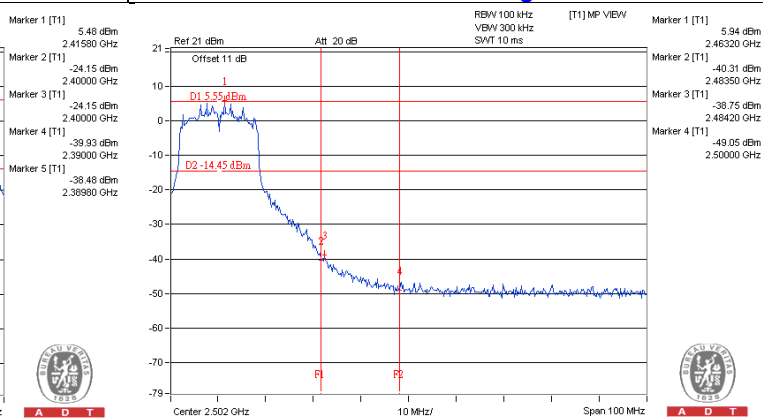
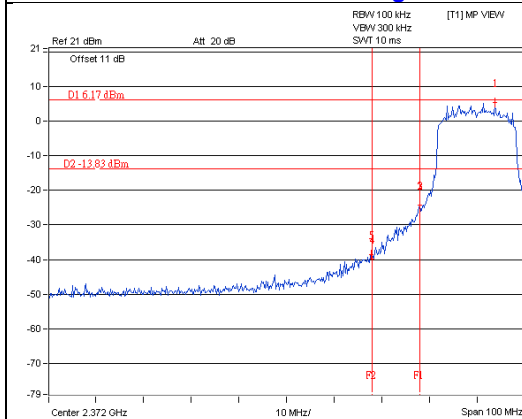

802.11n (HT20)

CH 1

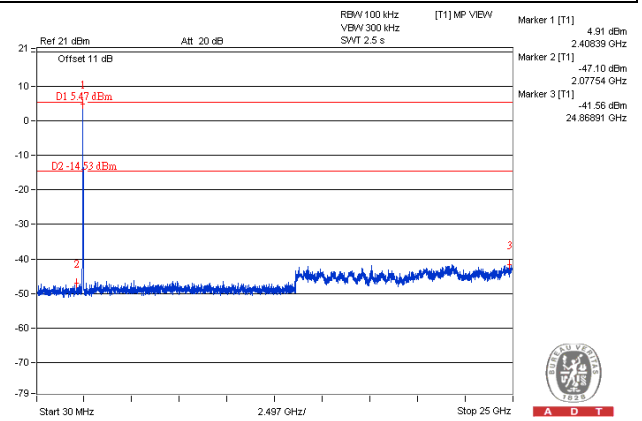
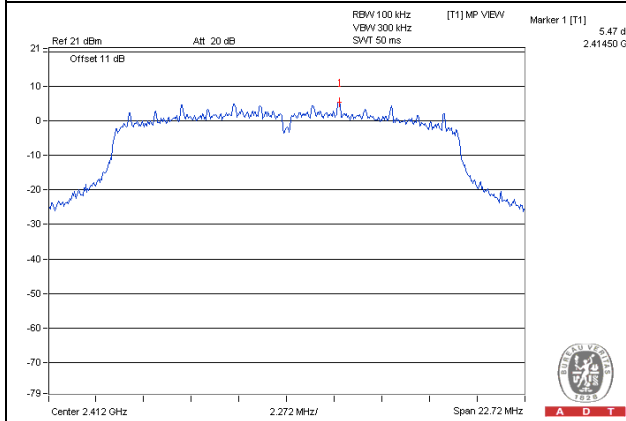

CH 6

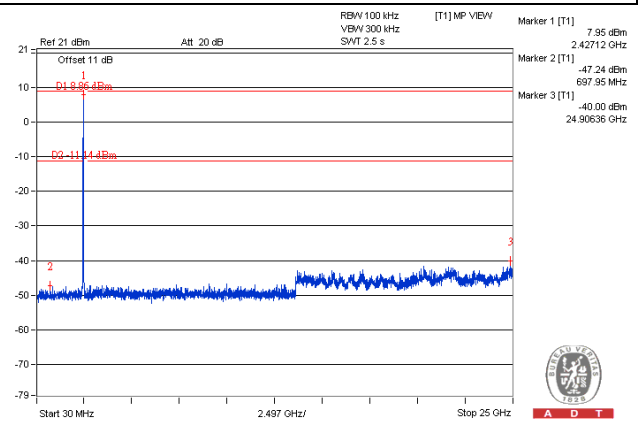
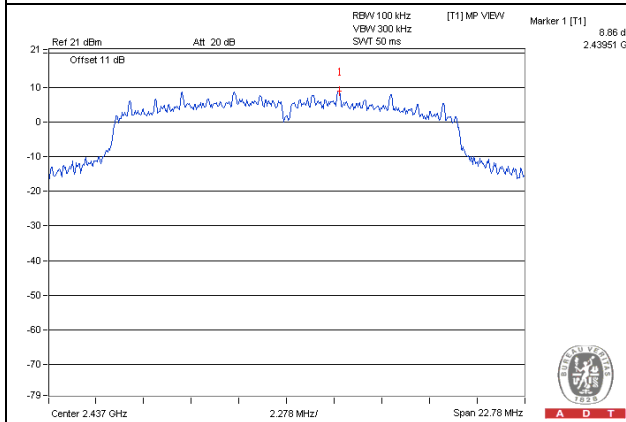

CH 11

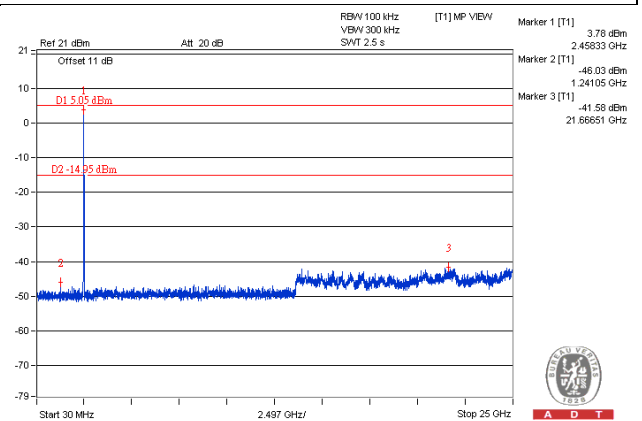
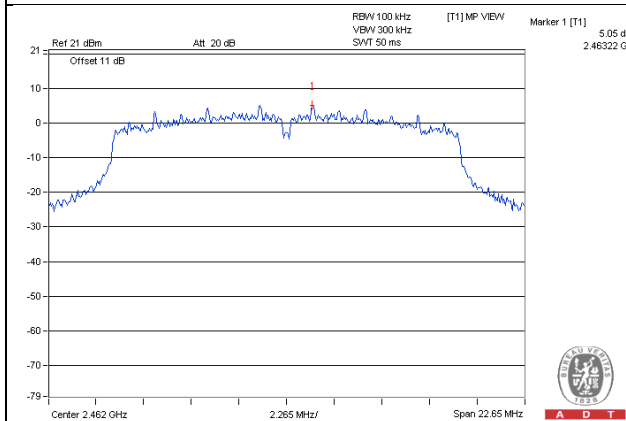

CH 1 Band edge

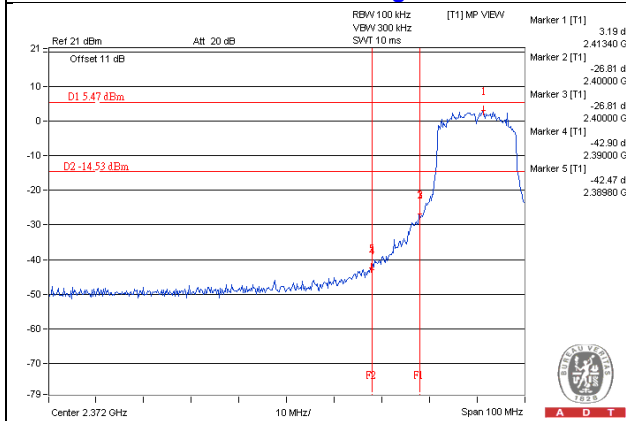

CH 11 Band edge

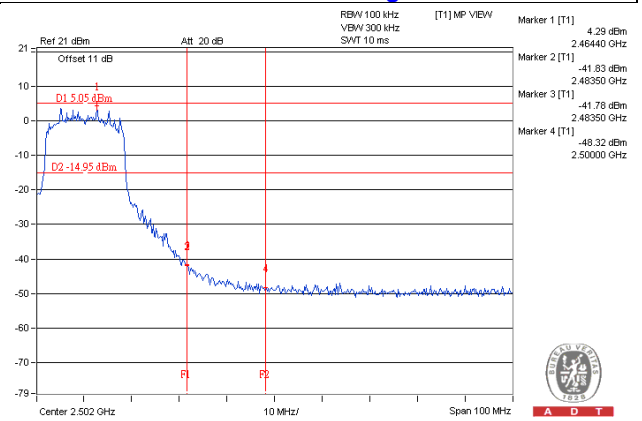

5 Pictures of Test Arrangements

Please refer to the attached file (Test Setup Photo).



Appendix – Information on the Testing Laboratories

We, Bureau Veritas Consumer Products Services (H.K.) Ltd., Taoyuan Branch, were founded in 1988 to provide our best service in EMC, Radio, Telecom and Safety consultation. Our laboratories are accredited and approved according to ISO/IEC 17025.

If you have any comments, please feel free to contact us at the following:

Linko EMC/RF Lab

Tel: 886-2-26052180

Fax: 886-2-26051924

Hsin Chu EMC/RF/Telecom Lab

Tel: 886-3-5935343

Fax: 886-3-5935342

Hwa Ya EMC/RF/Safety Lab

Tel: 886-3-3183232

Fax: 886-3-3270892

Email: service.adt@tw.bureauveritas.com

Web Site: www.bureauveritas-adt.com

The address and road map of all our labs can be found in our web site also.

--- END ---