

FCC RADIO TEST REPORT

according to

47 CFR FCC Part 15 Subpart E § 15.407

Equipment : Digital video recorder, computer for law enforcement
Model No. : M700 series-VMDC,MDC
Brand Name : COBAN
Filing Type : New Application
Applicant : Coban Technologies, Inc.
COBAN Technologies, 12503 Exchange Drive, Suite
536, Stafford, Texas 77477
Manufacturer : PEGATRON CORPORATION Taoyuan Mfg.
No.5, Shing Yeh St, Kwei Shan Hsiang, Taoyuan Hsien 333
TAIWAN
FCC ID : ZPJM700SERIESVMDC
Received Date : May 13, 2011
Final Test Date : May 23, 2011

Statement

Test result included is only for the 802.11a/n (5150~5350MHz; 5470~5725MHz) of the product.

The test result in this report refers exclusively to the presented test model / sample.

Without written approval of SPORTON International Inc., the test report shall not be reproduced except in full.

The measurements and test results shown in this test report were made in accordance with the procedures and found in compliance with the limit given in **ANSI C63.4-2003** and **47 CFR FCC Part 15 Subpart E**.

The test equipment used to perform the test is calibrated and traceable to NML/ROC.



SPORTON International Inc.

No. 52 Hwa Ya 1st Rd., Hwa Ya Technology Park, Kwei-Shan Hsiang, Tao Yuan Hsien, Taiwan, R.O.C.

Table of Contents

1 SUMMARY OF THE TEST RESULT	2
2 GENERAL INFORMATION.....	3
2.1 Product Details.....	3
2.2 Accessories.....	3
2.3 Table for Filed Antenna.....	3
2.4 Table for Carrier Frequencies	5
2.5 Table for Test Modes	6
2.6 Table for Testing Locations.....	7
2.7 Table for Supporting Units	7
2.8 Table for Parameters of Test Software Setting.....	7
2.9 EUT Operation during Test	8
2.10 Test Configuration.....	9
3 TEST RESULT	10
3.1 AC Power Line Conducted Emissions Measurement	10
3.2 99% Occupied Bandwidth Measurement.....	12
3.3 Maximum Conducted Output Power Measurement	48
3.4 Power Spectral Density Measurement.....	52
3.5 Peak Excursion Measurement	88
3.6 Radiated Emissions Measurement	123
3.7 Band Edge and Fundamental Emissions Measurement.....	219
3.8 Frequency Stability Measurement	235
3.9 Antenna Requirements	237
4 LIST OF MEASURING EQUIPMENTS.....	238
5 TEST LOCATION.....	239
6 TAF CERTIFICATE OF ACCREDITATION.....	240
APPENDIX A. MAXIMUM PERMISSIBLE EXPOSURE	A1 ~ A3
APPENDIX B. TEST PHOTOS	B1 ~ B6
APPENDIX C. PHOTOGRAPHS OF EUT	C1 ~ C41

CERTIFICATE OF COMPLIANCE

according to

47 CFR FCC Part 15 Subpart E § 15.407

Equipment : Digital video recorder, computer for law enforcement
Model No. : M700 series-VMDC,MDC
Brand Name : COBAN
Applicant : Coban Technologies, Inc.
COBAN Technologies,12503 Exchange Drive, Suite
536,Stafford, Texas 77477

Sporton International as requested by the applicant to evaluate the EMC performance of the product sample received on May 13, 2011 would like to declare that the tested sample has been evaluated and found to be in compliance with the tested rule parts. The data recorded as well as the test configuration specified is true and accurate for showing the sample's EMC nature.

Wayne Hsu / Assistant Manager

SPORTON International Inc.

No. 52 Hwa Ya 1st Rd., Hwa Ya Technology Park, Kwei-Shan Hsiang, Tao Yuan Hsien, Taiwan, R.O.C.

1 SUMMARY OF THE TEST RESULT

Applied Standard: 47 CFR FCC Part 15 Subpart E				
Part	Rule Section	Description of Test	Result	Under Limit
3.1	15.207	AC Power Line Conducted Emissions	Complies	-
3.2	15.407(a)	26dB Spectrum Bandwidth	Complies	-
3.3	15.407(a)	Maximum Conducted Output Power	Complies	0.49 dB
3.4	15.407(a)	Power Spectral Density	Complies	0.03 dB
3.5	15.407(a)	Peak Excursion	Complies	4.69 dB
3.6	15.407(b)	Radiated Emissions	Complies	3.01 dB
3.7	15.407(b)	Band Edge Emissions	Complies	1.04 dB
3.8	15.407(g)	Frequency Stability	Complies	-
3.9	15.203	Antenna Requirements	Complies	-

Test Items	Uncertainty	Remark
AC Power Line Conducted Emissions	±2.3dB	Confidence levels of 95%
Maximum Conducted Output Power	±0.5dB	Confidence levels of 95%
Power Spectral Density	±0.5dB	Confidence levels of 95%
Peak Excursion	±0.5dB	Confidence levels of 95%
26dB Spectrum Bandwidth / Frequency Stability	±8.5×10 ⁻⁸	Confidence levels of 95%
Radiated Emissions (9kHz~30MHz)	±0.8dB	Confidence levels of 95%
Radiated Emissions (30MHz~1000MHz)	±1.9dB	Confidence levels of 95%
Radiated / Band Edge Emissions (1GHz~18GHz)	±1.9dB	Confidence levels of 95%
Radiated Emissions (18GHz~40GHz)	±1.9dB	Confidence levels of 95%
Temperature	±0.7°C	Confidence levels of 95%
Humidity	±3.2%	Confidence levels of 95%
DC / AC Power Source	±1.4%	Confidence levels of 95%

2 GENERAL INFORMATION

2.1 Product Details

Only the radio detail of IEEE 802.11a/n is shown in this report. For more detailed features description, please refer to the manufacturer's specifications or user's manual.

Items	Description
Power Type	12V DC source
Modulation	OFDM for IEEE 802.11a/n
Data Modulation	OFDM (BPSK / QPSK / 16QAM / 64QAM) for IEEE 802.11a
Data Rate (Mbps)	See the item 2.3 table for IEEE 802.11n
Frequency Range	5150~5350MHz; 5470~5725MHz
Channel Band Width (99%)	802.11a: Band 1: 17.50 MHz ; Band 2: 19.50 MHz ; Band 3: 18.70 MHz 802.11n: MCS 0 (20MHz) : Band 1: 18.60 MHz ; Band 2: 20.60 MHz ; Band 3: 19.30 MHz MCS 0 (40MHz) : Band 1: 38.00 MHz ; Band 2: 36.80 MHz ; Band 3: 37.00 MHz MCS 8 (20MHz) : Band 1: 18.00 MHz ; Band 2: 19.30 MHz ; Band 3: 28.60 MHz MCS 8 (40MHz) : Band 1: 35.40 MHz ; Band 2: 42.00 MHz ; Band 3: 45.60 MHz
Conducted Output Power	802.11a: Band 1: 14.43 dBm ; Band 2: 16.18 dBm ; Band 3: 16.08 dBm 802.11n: MCS 0 (20MHz) : Band 1: 14.23 dBm ; Band 2: 16.12 dBm ; Band 3: 16.16 dBm MCS 0 (40MHz) : Band 1: 16.51 dBm ; Band 2: 16.12 dBm ; Band 3: 16.31 dBm MCS 8 (20MHz) : Band 1: 14.20 dBm ; Band 2: 19.25 dBm ; Band 3: 19.28 dBm MCS 8 (40MHz) : Band 1: 14.71 dBm ; Band 2: 19.27 dBm ; Band 3: 19.25 dBm

2.2 Accessories

Please refer to the specifications or user's manual.

2.3 Table for Filed Antenna

Antenna & Bandwidth

Antenna Mode	Single Chain		Two Chain	
	20 MHz	40 MHz	20 MHz	40 MHz
Bandwidth Mode				
802.11a (5150~5250MHz)	V	X	X	X
802.11a (5250~5350MHz)	V	X	X	X
802.11a (5470~5725MHz)	V	X	X	X
5G 802.11n (5150~5250MHz)	V	V	V	V
5G 802.11n (5250~5350MHz)	V	V	V	V
5G 802.11n (5470~5725MHz)	V	V	V	V

Ant.	Antenna Type	Connector	Gain (dBi)	Remark
A	Monopole Antenna	Reversed-SMA	0	TX / RX
B	Monopole Antenna	Reversed-SMA	0	TX / RX

Note:

1. IEEE 802.11a used one antenna is for signal transmitting and receiving.
2. IEEE 802.11n used two antennas are for signal transmitting and receiving.
(2T2R Spatial Multiplexing MIMO configuration)
Directional gain = GANT + 10 log(N) dBi = 0 + 10 log(2) = 3 dBi

IEEE 802.11n Modulation Scheme

MCS Index	Nss	Modulation	R	NBPS	NCBPS		NDBPS		Data rate(Mbps)			
					800nsGI		20MHz	40MHz	20MHz	40MHz	20MHz	40MHz
					20MHz	40MHz						
0	1	BPSK	1/2	1	52	108	26	54	6.5	13.5		
1	1	QPSK	1/2	2	104	216	52	108	13.0	27.0		
2	1	QPSK	3/4	2	104	216	78	162	19.5	40.5		
3	1	16-QAM	1/2	4	208	432	104	216	26.0	54.0		
4	1	16-QAM	3/4	4	208	432	156	324	39.0	81.0		
5	1	64-QAM	2/3	6	312	648	208	432	52.0	108.0		
6	1	64-QAM	3/4	6	312	648	234	486	58.5	121.5		
7	1	64-QAM	5/6	6	312	648	260	540	65.0	135.0		
8	2	BPSK	1/2	1	104	216	52	108	13.0	27.0		
9	2	QPSK	1/2	2	208	432	104	216	26.0	54.0		
10	2	QPSK	3/4	2	208	432	156	324	39.0	81.0		
11	2	16-QAM	1/2	4	416	864	208	432	52.0	108.0		
12	2	16-QAM	3/4	4	416	864	312	648	78.0	162.0		
13	2	64-QAM	2/3	6	624	1296	416	864	104.0	216.0		
14	2	64-QAM	3/4	6	624	1296	468	972	117.0	243.0		
15	2	64-QAM	5/6	6	624	1296	520	1080	130.0	270.0		

Symbol	Explanation
NSS	Number of spatial streams
R	Code rate
NBPS	Number of coded bits per single carrier
NCBPS	Number of coded bits per symbol
NDBPS	Number of data bits per symbol
GI	guard interval

2.4 Table for Carrier Frequencies

Frequency Band	Channel No.	Frequency (20MHz)	Channel No.	Frequency (40MHz)
5150~5250 MHz Band 1	36	5180 MHz	38	5190 MHz
	40	5200 MHz	46	5230 MHz
	44	5220 MHz	-	-
	48	5240 MHz	-	-

Frequency Band	Channel No.	Frequency (20MHz)	Channel No.	Frequency (40MHz)
5250~5350 MHz Band 2	52	5260 MHz	54	5270 MHz
	56	5280 MHz	62	5310 MHz
	60	5300 MHz	-	-
	64	5320 MHz	-	-

Frequency Band	Channel No.	Frequency (20MHz)
5470~5725 MHz Band 3	100	5500 MHz
	104	5520 MHz
	108	5540 MHz
	112	5560 MHz
	116	5580 MHz
	132	5660 MHz
	136	5680 MHz
	140	5700 MHz
	Channel No.	Frequency (40MHz)
	102	5510 MHz
	110	5550 MHz
	134	5670 MHz

2.5 Table for Test Modes

Preliminary tests were performed in different data rate to find the worst radiated emission. The data rate shown in the table below is the worst-case rate with respect to the specific test item. Investigation has been done on the entire possible Configuration for searching the worst cases. The following table is a list of the test modes shown in this test report.

Test Items	Mode	Data Rate	Channel	Antenna
AC Power Conducted Emission	-	-	-	-
Max. Conducted Output Power Power Spectral Density	11a Band 1~3/BPSK	6Mbps	36/40/48/52/56 /64/100/116/140	A
	11n Band 1~3/BPSK MCS 0 (20MHz)	6.5Mbps		
	11n Band 1~3/BPSK MCS 0 (40MHz)	13.5Mbps	38/46/54/62/102/110/134	A/B; A+B
	11n Band 1~3/BPSK MCS 8 (20MHz)	13 Mbps	36/40/48/52/56 /64/100/116/140	
	11n Band 1~3/BPSK MCS 8 (40MHz)	27 Mbps	38/46/54/62/102/110/134	
26dB Spectrum Bandwidth 99% Occupied Bandwidth Measurement Peak Excursion	11a Band 1~3/BPSK	6Mbps	36/40/48/52/56 /64/100/116/140	A
	11n Band 1~3/BPSK MCS 0 (20MHz)	6.5Mbps		
	11n Band 1~3/BPSK MCS 0 (40MHz)	13.5Mbps	38/46/54/62/102/110/134	A/B
	11n Band 1~3/BPSK MCS 8 (20MHz)	13 Mbps	36/40/48/52/56 /64/100/116/140	
	11n Band 1~3/BPSK MCS 8 (40MHz)	27 Mbps	38/46/54/62/102/110/134	
Radiated Emission Below 1GHz	11a Band 1~3/BPSK	6Mbps	116	A
	11n Band 1~3/BPSK MCS 0 (20MHz)	6.5Mbps		
	11n Band 1~3/BPSK MCS 0 (40MHz)	13.5Mbps	110	A+B
	11n Band 1~3/BPSK MCS 8 (20MHz)	13 Mbps	116	
	11n Band 1~3/BPSK MCS 8 (40MHz)	27 Mbps	110	
Radiated Emission Above 1GHz Fundamental Emissions	11a Band 1~3/BPSK	6Mbps	36/40/48/52/56 /64/100/116/140	A
	11n Band 1~3/BPSK MCS 0 (20MHz)	6.5Mbps		
	11n Band 1~3/BPSK MCS 0 (40MHz)	13.5Mbps	38/46/54/62/102/110/134	A+B
	11n Band 1~3/BPSK MCS 8 (20MHz)	13 Mbps	36/40/48/52/56 /64/100/116/140	
	11n Band 1~3/BPSK MCS 8 (40MHz)	27 Mbps	38/46/54/62/102/110/134	

2.6 Table for Testing Locations

Test Site No.	Site Category	Location
TH01-HY	OVEN Room	Hwa Ya
03CH03-HY	SAC	Hwa Ya

Semi Anechoic Chamber (SAC).

2.7 Table for Supporting Units

Support Unit	Brand	Model	FCC ID	Remark
LCD Monitor	DELL	1703FPt	DoC	Radiated
Mouse	Logitech	M-BE58	DoC	

2.8 Table for Parameters of Test Software Setting

During testing, Channel & Power Controlling Software provided by the customer was used to control the operating channel as well as the output power level. The RF output power selection is for the setting of RF output power expected by the customer and is going to be fixed on the firmware of the final end product.

For Single Chain:

Power Parameters of IEEE 802.11a

Test Software Version	CRTU		
Frequency	5180 MHz	5200 MHz	5240 MHz
IEEE 802.11a (Ant. A)	16	17	16
Frequency	5260 MHz	5280 MHz	5320 MHz
IEEE 802.11a (Ant. A)	27	28	27
Frequency	5500 MHz	5580 MHz	5700 MHz
IEEE 802.11a (Ant. A)	26	17.5	26

Power Parameters of IEEE 802.11n (20MHz)

Test Software Version	CRTU		
Frequency	5180 MHz	5200 MHz	5240 MHz
IEEE 802.11n (Ant. A)	16	17	16
Frequency	5260 MHz	5280 MHz	5320 MHz
IEEE 802.11n (Ant. A)	27	27.5	28
Frequency	5500 MHz	5580 MHz	5700 MHz
IEEE 802.11n (Ant. A)	25.5	18	26

Power Parameters of IEEE 802.11n (40MHz)

Test Software Version	CRTU		
Frequency	5190 MHz	5230 MHz	5270 MHz
IEEE 802.11n (Ant. A)	11.5	19	19
Frequency	5310 MHz	5510 MHz	5550 MHz
IEEE 802.11n (Ant. A)	22.5	27	18
Frequency	5670 MHz		
IEEE 802.11n (Ant. A)	18.5		

For Two Chain:

Power Parameters of IEEE 802.11n Ant. A+Ant. B

Test Software Version	CRTU		
Frequency	5180 MHz	5200 MHz	5240 MHz
IEEE 802.11n(20MHz)	13	13	12
Frequency	5260 MHz	5280 MHz	5320 MHz
IEEE 802.11n(20MHz)	30.5/30	31.5/30.5	30/28
Frequency	5500 MHz	5580 MHz	5700 MHz
IEEE 802.11n(20MHz)	30.5/32	30/31	31/37

Power Parameters of IEEE 802.11n Ant. A+Ant. B

Test Software Version	CRTU		
Frequency	5190 MHz	5230 MHz	5270 MHz
IEEE 802.11n(40MHz)	10	13.5	33.5/32.5
Frequency	5310 MHz	5510 MHz	5550 MHz
IEEE 802.11n(40MHz)	26/22.5	14	18
Frequency	5670 MHz		
IEEE 802.11n(40MHz)	32.5/36.5		

2.9 EUT Operation during Test

Only Radiated used:

- Executed "CRTU" to keep transmitting signals at fixed frequency.

2.10 Test Configuration

**Radiation Emissions Test Configuration
For radiated emissions 9kHz~1GHz**

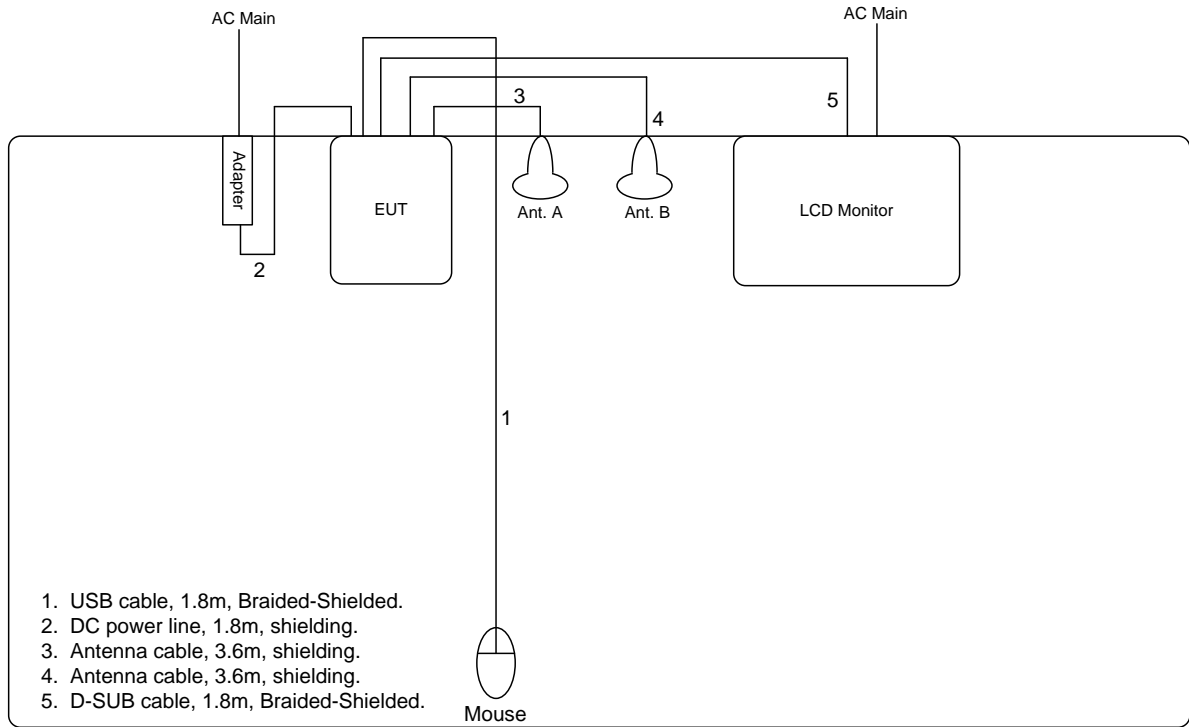

For radiated emissions above 1GHz

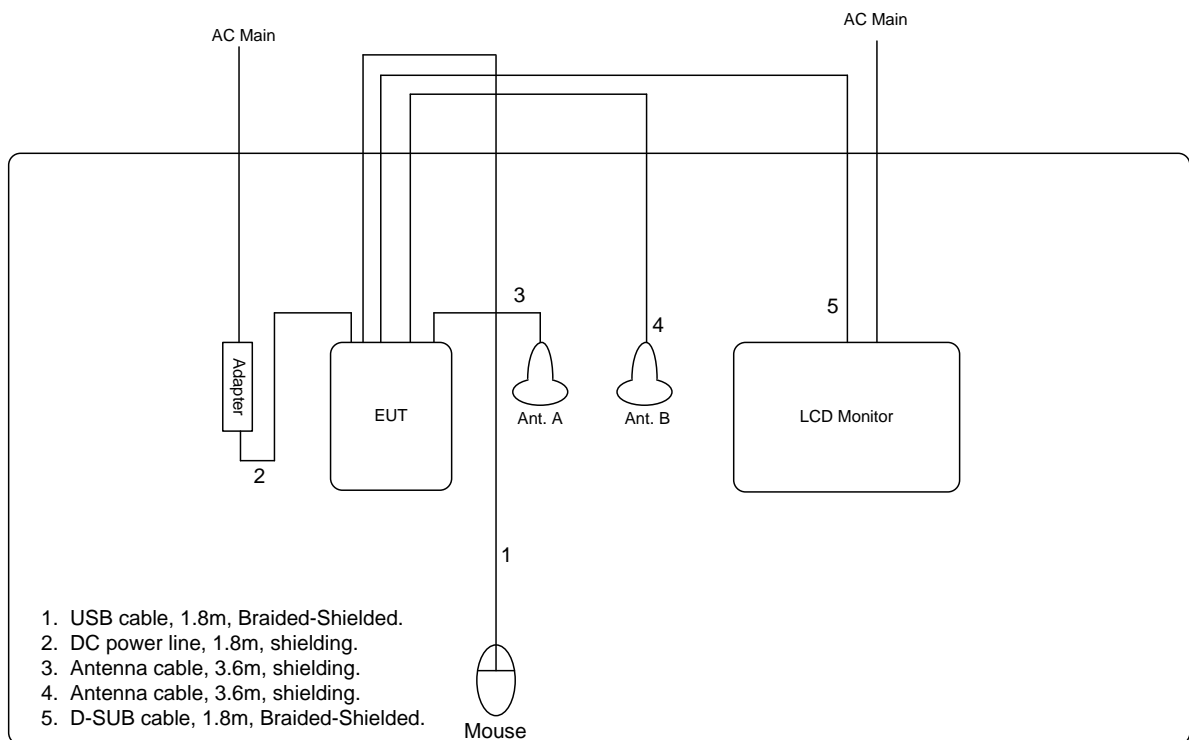

3 TEST RESULT

3.1 AC Power Line Conducted Emissions Measurement

3.1.1 Limit

For this product which is designed to be connected to the AC power line, the radio frequency voltage that is conducted back onto the AC power line on any frequency or frequencies within the band 150 kHz to 30 MHz shall not exceed below limits table.

Class B

Frequency (MHz)	QP Limit (dBuV)	AV Limit (dBuV)
0.15~0.5	66~56	56~46
0.5~5	56	46
5~30	60	50

3.1.2 Measuring Instruments and Setting

Please refer to section 4 of equipments list in this report. The following table is the setting of the receiver.

Receiver Parameters	Setting
Attenuation	10 dB
Start Frequency	0.15 MHz
Stop Frequency	30 MHz
IF Bandwidth	9 KHz

3.1.3 Test Procedures

1. The EUT warm up about 15 minutes then start test.
2. Configure the EUT according to ANSI C63.4. The EUT or host of EUT has to be placed 0.4 meter far from the conducting wall of the shielding room and at least 80 centimeters from any other grounded conducting surface.
3. Connect EUT or host of EUT to the power mains through a line impedance stabilization network (LISN).
4. All the support units are connected to the other LISNs. The LISN should provide 50uH/50ohms coupling impedance.
5. The frequency range from 150 KHz to 30 MHz was searched.
6. Set the test-receiver system to Peak Detect Function and Specified Bandwidth with Maximum Hold Mode.
7. The measurement has to be done between each power line and ground at the power terminal.

3.1.4 Test Setup Layout

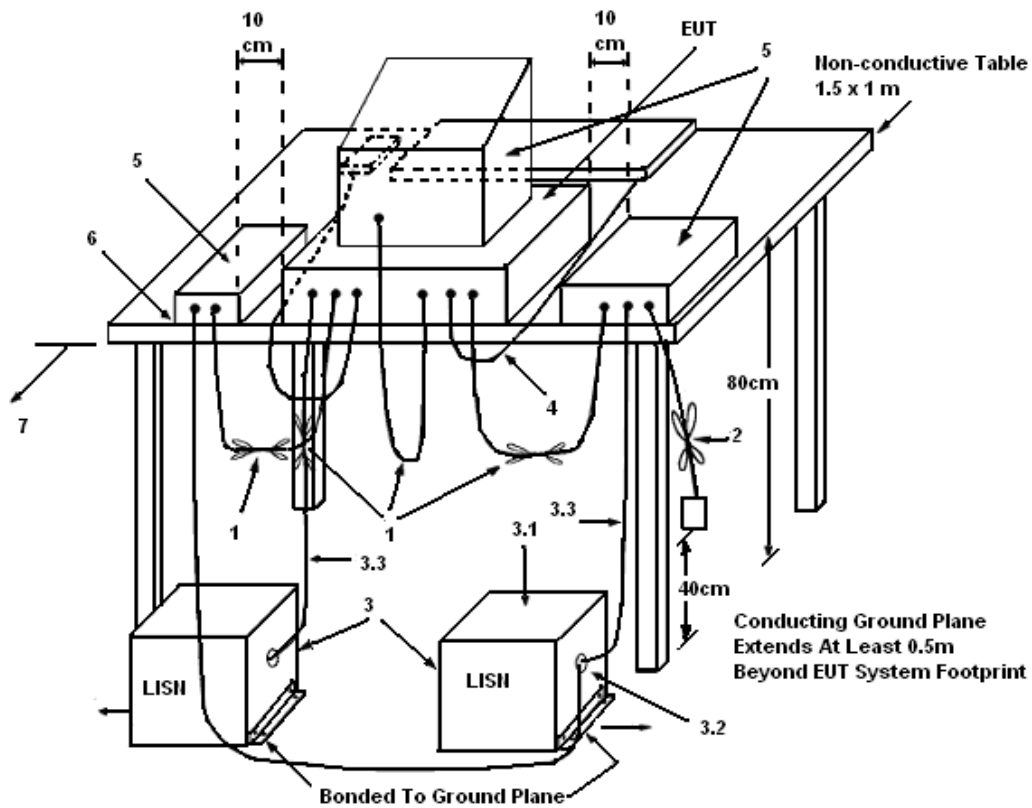

LEGEND:

- (1) Interconnecting cables that hang closer than 40 cm to the ground plane shall be folded back and forth in the center forming a bundle 30 to 40 cm long.
- (2) I/O cables that are not connected to a peripheral shall be bundled in the center. The end of the cable may be terminated, if required, using the correct terminating impedance. The overall length shall not exceed 1 m.
- (3) EUT connected to one LISN. Unused LISN measuring port connectors shall be terminated in 50 Ω. LISN can be placed on top of, or immediately beneath, reference ground plane.
- (3.1) All other equipment powered from additional LISN(s).
- (3.2) Multiple outlet strip can be used for multiple power cords of non-EUT equipment.
- (3.3) LISN at least 80 cm from nearest part of EUT chassis.
- (4) Cables of hand-operated devices, such as keyboards, mice, etc., shall be placed as for normal use.
- (5) Non-EUT components of EUT system being tested.
- (6) Rear of EUT, including peripherals, shall all be aligned and flush with rear of tabletop.
- (7) Rear of tabletop shall be 40 cm removed from a vertical conducting plane that is bonded to the ground plane.

3.1.5 Test Deviation

There is no deviation with the original standard.

3.1.6 EUT Operation during Test

The EUT was placed on the test table and programmed in normal function.

3.1.7 Results of AC Power Line Conducted Emissions Measurement

The EUT is power by DC source so there is no need to do this test.

3.2 99% Occupied Bandwidth Measurement

3.2.1 Limit

No restriction limits. But resolution bandwidth within band edge measurement is 1% of the 99% occupied bandwidth.

3.2.2 Measuring Instruments and Setting

Please refer to section 4 of equipments list in this report. The following table is the setting of the spectrum analyzer.

Spectrum Parameters	Setting
Attenuation	Auto
Span Frequency	> 26dB Bandwidth
RB	300 kHz
VB	1000 kHz
Detector	Peak
Trace	Max Hold
Sweep Time	Auto

3.2.3 Test Procedures

1. The transmitter output (antenna port) was connected to the spectrum analyzer in peak hold mode.
2. The resolution bandwidth of 300 kHz and the video bandwidth of 1000 kHz were used.
3. Measured the spectrum width with power higher than 26dB below carrier.

3.2.4 Test Setup Layout

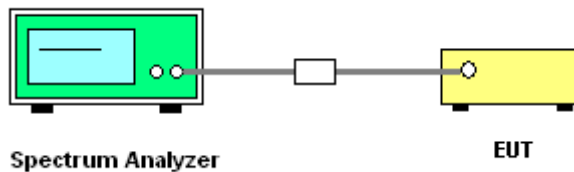

3.2.5 Test Deviation

There is no deviation with the original standard.

3.2.6 EUT Operation during Test

The EUT was programmed to be in continuously transmitting mode.

3.2.7 Test Result of 99% Occupied Bandwidth

Final Test Date	May 23, 2011	Test Site No.	TH01-HY
Temperature	27°C	Humidity	62%
Test Engineer	Ian	Configurations	802.11a/n

**For Single Chain:
Configuration of IEEE 802.11a Ant. A**

Channel	Frequency	26dB Bandwidth (MHz)	99% Occupied Bandwidth (MHz)
36	5180 MHz	29.20	17.10
40	5200 MHz	34.30	17.50
48	5240 MHz	29.10	17.20
52	5260 MHz	34.70	18.40
56	5280 MHz	36.80	19.50
64	5320 MHz	35.30	17.60
100	5500 MHz	36.00	18.70
116	5580 MHz	33.50	17.50
140	5700 MHz	35.20	18.40

Configuration IEEE 802.11n (20MHz) Ant. A

Channel	Frequency	26dB Bandwidth (MHz)	99% Occupied Bandwidth (MHz)
36	5180 MHz	34.60	18.20
40	5200 MHz	35.70	18.60
48	5240 MHz	32.70	18.30
52	5260 MHz	40.60	19.70
56	5280 MHz	40.70	20.00
64	5320 MHz	40.80	20.60
100	5500 MHz	40.70	19.20
116	5580 MHz	40.70	19.00
140	5700 MHz	40.50	19.30

Configuration IEEE 802.11n (40MHz) Ant. A

Channel	Frequency	26dB Bandwidth (MHz)	99% Occupied Bandwidth (MHz)
38	5190 MHz	39.00	35.20
46	5230 MHz	73.40	38.00
54	5270 MHz	72.80	36.80
62	5310 MHz	39.20	35.60
102	5510 MHz	66.20	36.20
110	5550 MHz	65.80	36.00
134	5670 MHz	69.00	37.00

**For Two Chain:
Configuration IEEE 802.11n (20MHz) Ant. A**

Channel	Frequency	26dB Bandwidth (MHz)	99% Occupied Bandwidth (MHz)
36	5180 MHz	21.60	17.90
40	5200 MHz	21.40	17.90
48	5240 MHz	21.60	17.90
52	5260 MHz	32.20	18.40
56	5280 MHz	35.10	18.80
64	5320 MHz	32.50	18.30
100	5500 MHz	31.70	18.30
116	5580 MHz	30.00	18.20
140	5700 MHz	33.40	18.50

Configuration IEEE 802.11n (20MHz) Ant. B

Channel	Frequency	26dB Bandwidth (MHz)	99% Occupied Bandwidth (MHz)
36	5180 MHz	21.50	18.00
40	5200 MHz	21.10	18.00
48	5240 MHz	21.00	18.00
52	5260 MHz	33.60	18.60
56	5280 MHz	35.30	19.30
64	5320 MHz	30.20	18.20
100	5500 MHz	37.10	19.20
116	5580 MHz	33.50	18.50
140	5700 MHz	45.10	28.60

Configuration IEEE 802.11n (40MHz) Ant. A

Channel	Frequency	26dB Bandwidth (MHz)	99% Occupied Bandwidth (MHz)
38	5190 MHz	38.60	35.40
46	5230 MHz	41.20	35.40
54	5270 MHz	69.60	41.20
62	5310 MHz	38.60	35.60
102	5510 MHz	56.80	35.60
110	5550 MHz	65.60	36.40
134	5670 MHz	67.60	39.60

Configuration IEEE 802.11n (40MHz) Ant. B

Channel	Frequency	26dB Bandwidth (MHz)	99% Occupied Bandwidth (MHz)
38	5190 MHz	38.40	35.40
46	5230 MHz	38.40	35.40
54	5270 MHz	72.40	42.00
62	5310 MHz	38.40	35.40
102	5510 MHz	38.40	35.40
110	5550 MHz	65.20	36.00
134	5670 MHz	66.80	36.40

For Single Chain:
26 dB Bandwidth Plot on Configuration IEEE 802.11a Ant. A / 5180 MHz

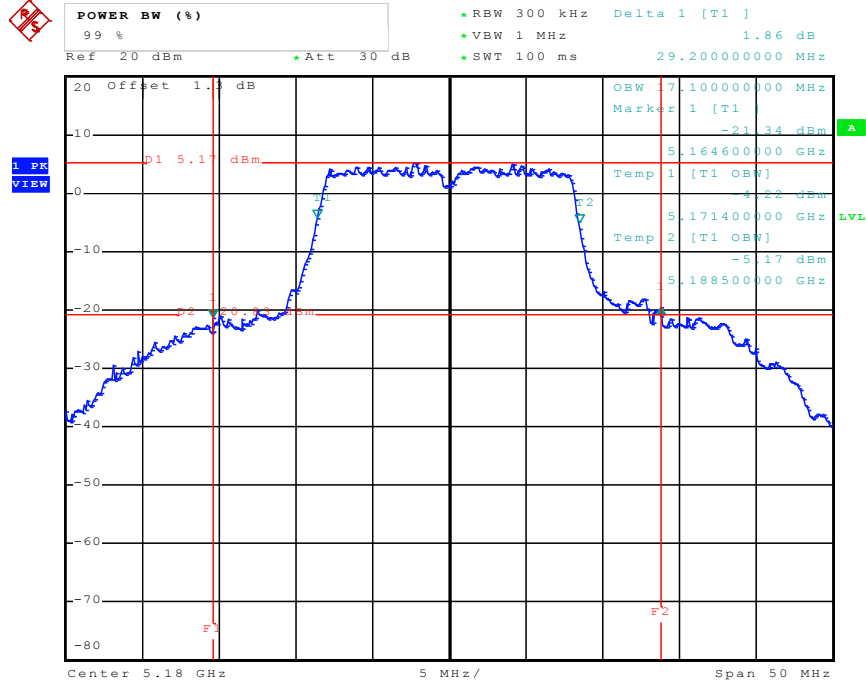

Date: 23.MAY.2011 11:23:02

26 dB Bandwidth Plot on Configuration IEEE 802.11a Ant. A / 5200 MHz

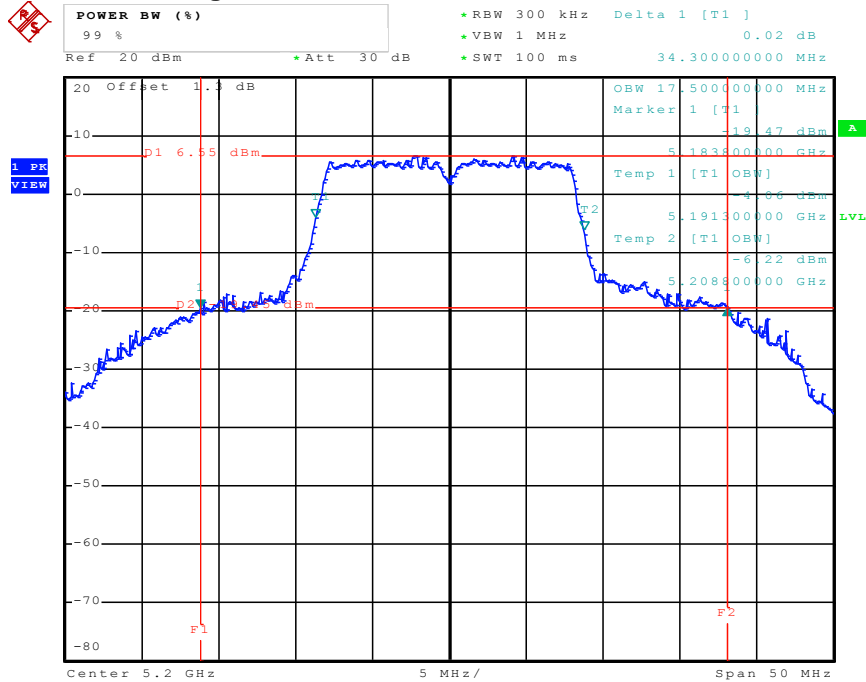

Date: 3.MAY.2011 11:55:31

26 dB Bandwidth Plot on Configuration IEEE 802.11a Ant. A / 5240 MHz

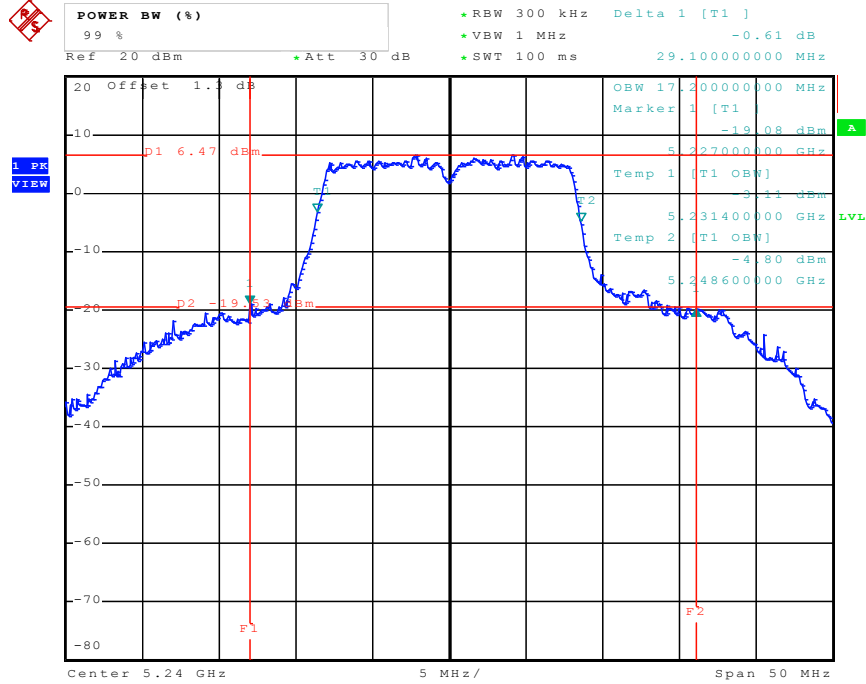

Date: 3.MAY.2011 11:59:57

26 dB Bandwidth Plot on Configuration IEEE 802.11a Ant. A / 5260 MHz

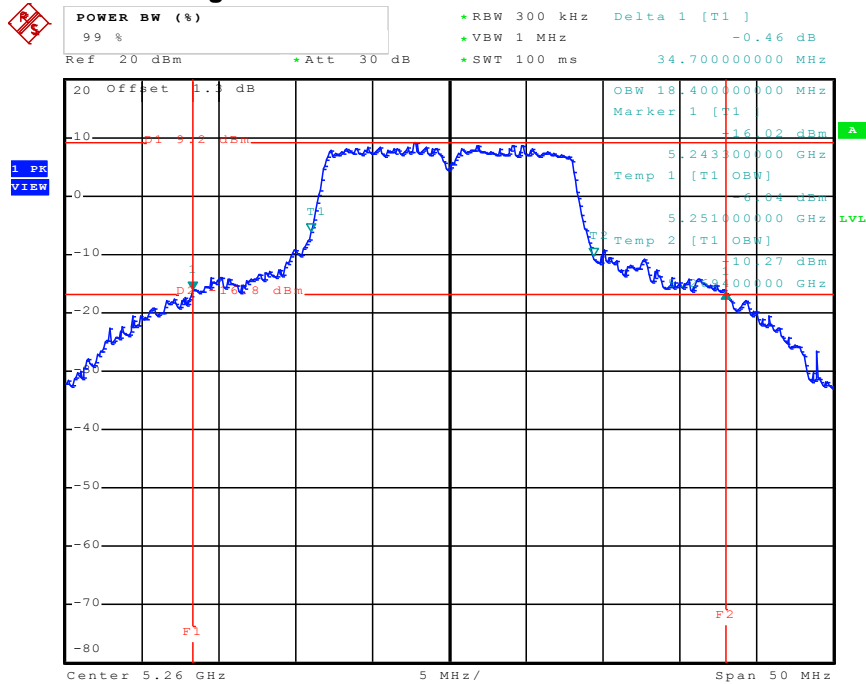

Date: 3.MAY.2011 12:02:44

26 dB Bandwidth Plot on Configuration IEEE 802.11a Ant. A / 5280 MHz

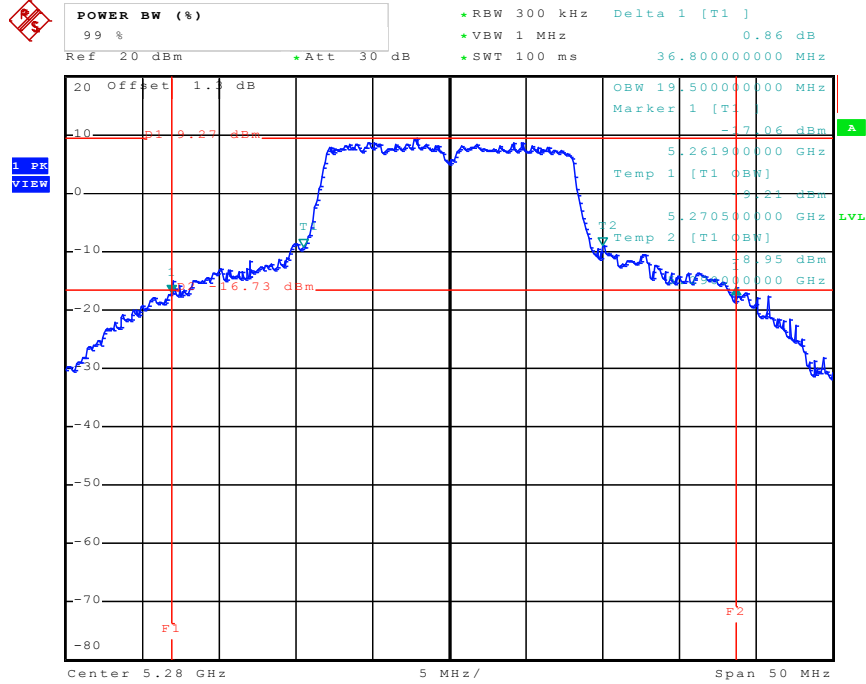

Date: 3.MAY.2011 12:08:26

26 dB Bandwidth Plot on Configuration IEEE 802.11a Ant. A / 5320 MHz

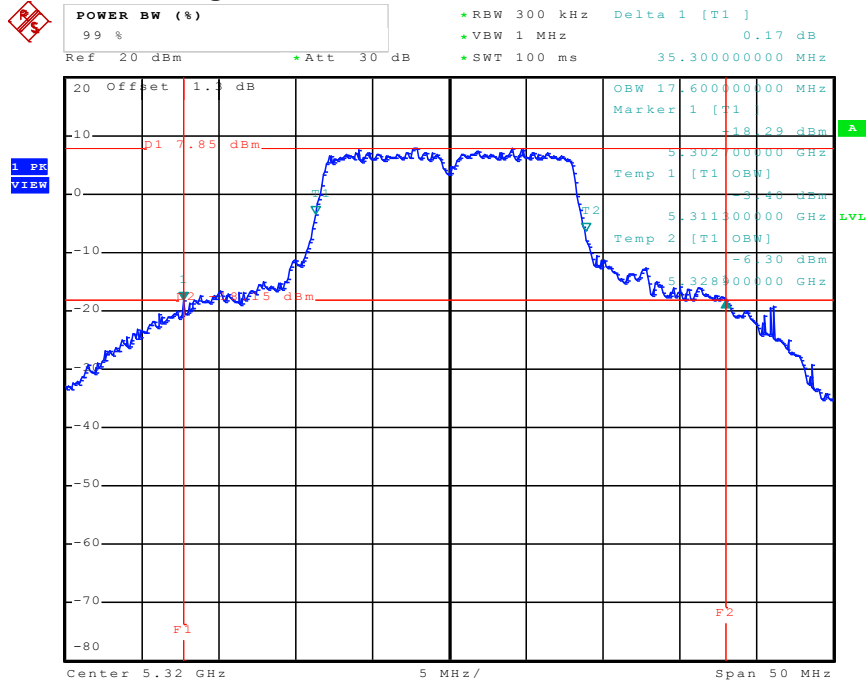

Date: 23.MAY.2011 11:37:02

26 dB Bandwidth Plot on Configuration IEEE 802.11a Ant. A / 5500 MHz

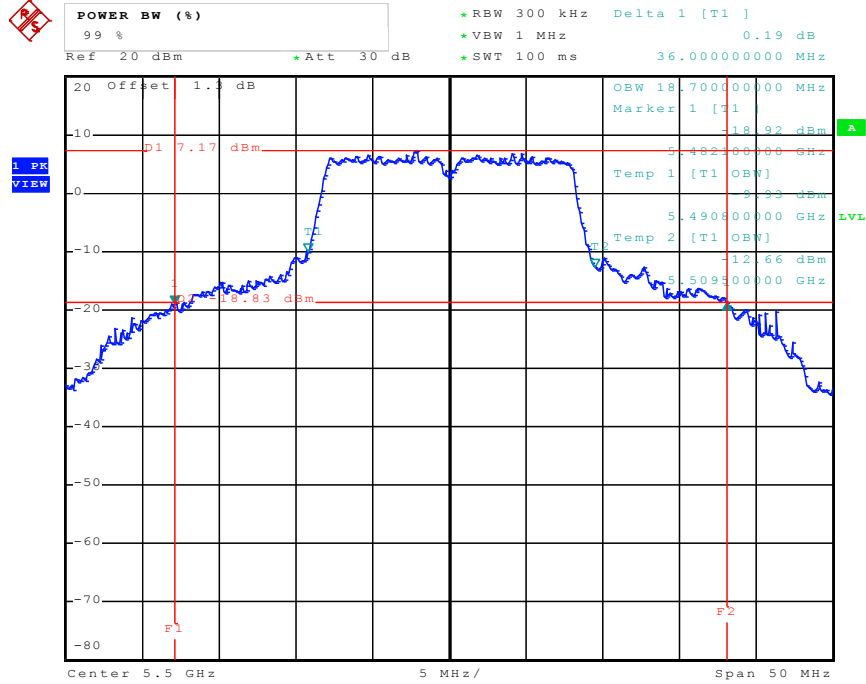

Date: 3.MAY.2011 12:14:04

26 dB Bandwidth Plot on Configuration IEEE 802.11a Ant. A / 5580 MHz

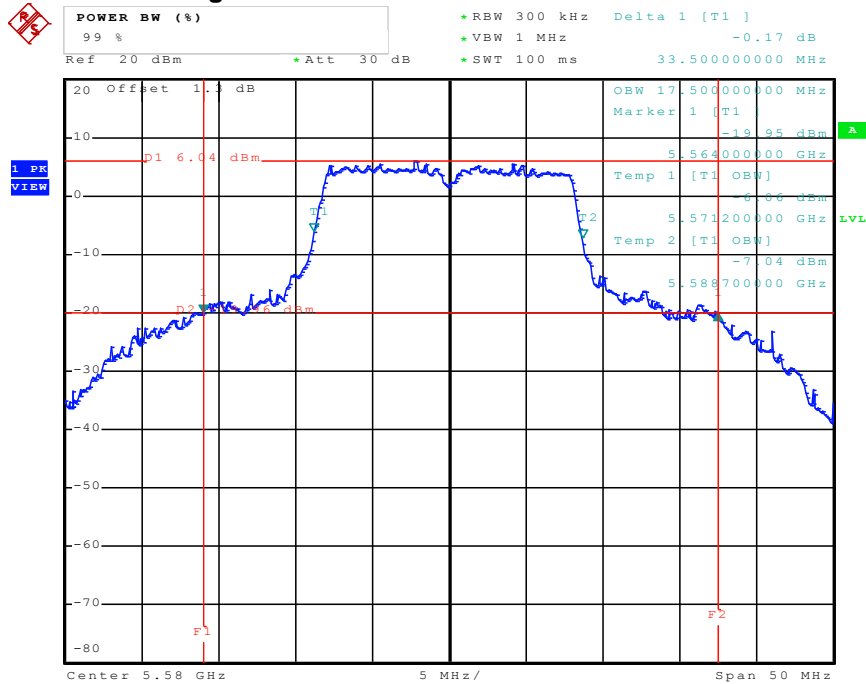

Date: 3.MAY.2011 12:17:16

26 dB Bandwidth Plot on Configuration IEEE 802.11a Ant. A / 5700 MHz

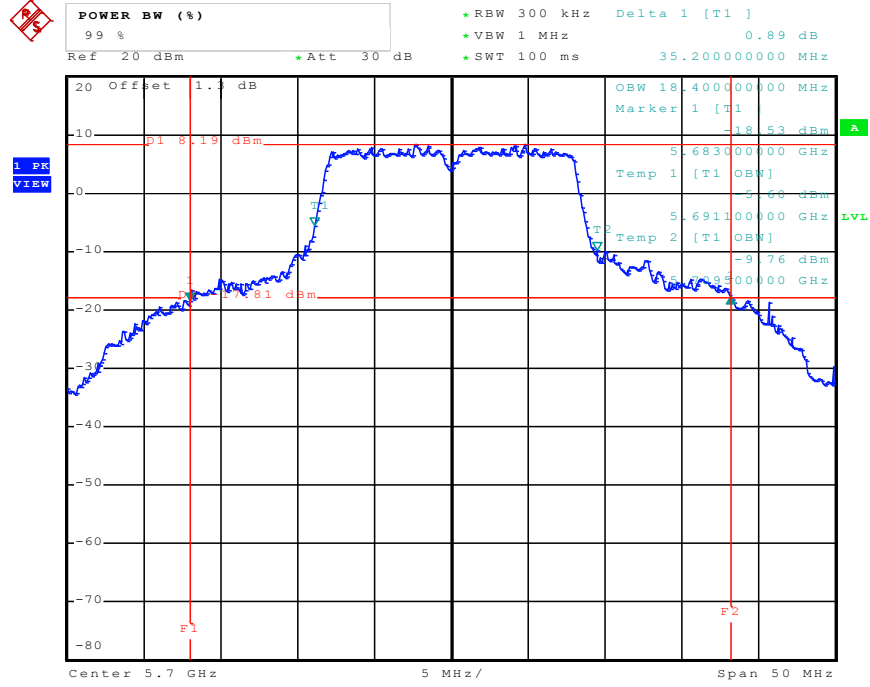

Date: 3.MAY.2011 12:19:33

26 dB Bandwidth Plot on Configuration IEEE 802.11n Ant. A (20MHz) / 5180 MHz

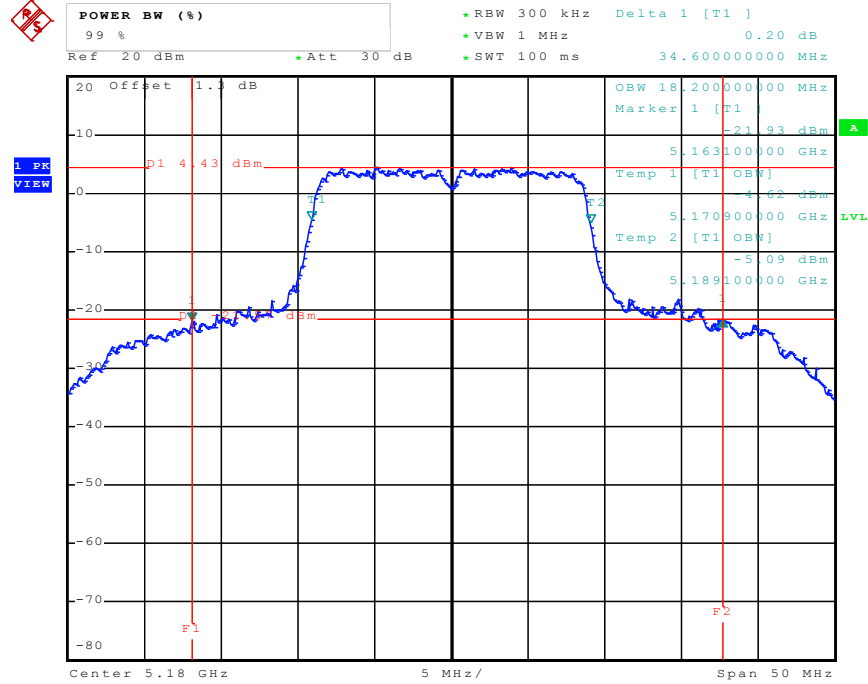

Date: 23.MAY.2011 11:51:32

26 dB Bandwidth Plot on Configuration IEEE 802.11n Ant. A (20MHz) / 5200 MHz

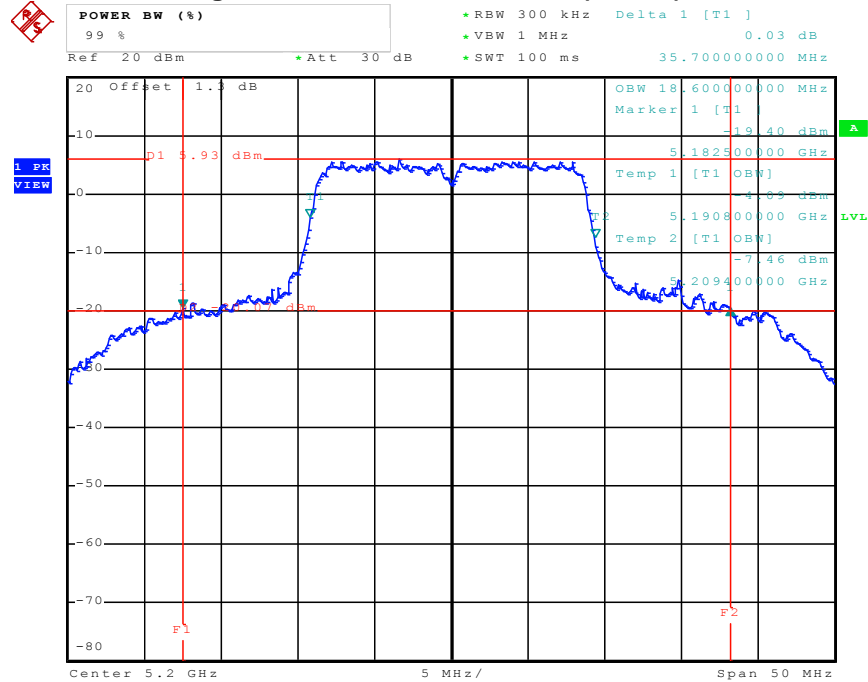

Date: 3.MAY.2011 14:32:45

26 dB Bandwidth Plot on Configuration IEEE 802.11n Ant. A (20MHz) / 5240 MHz

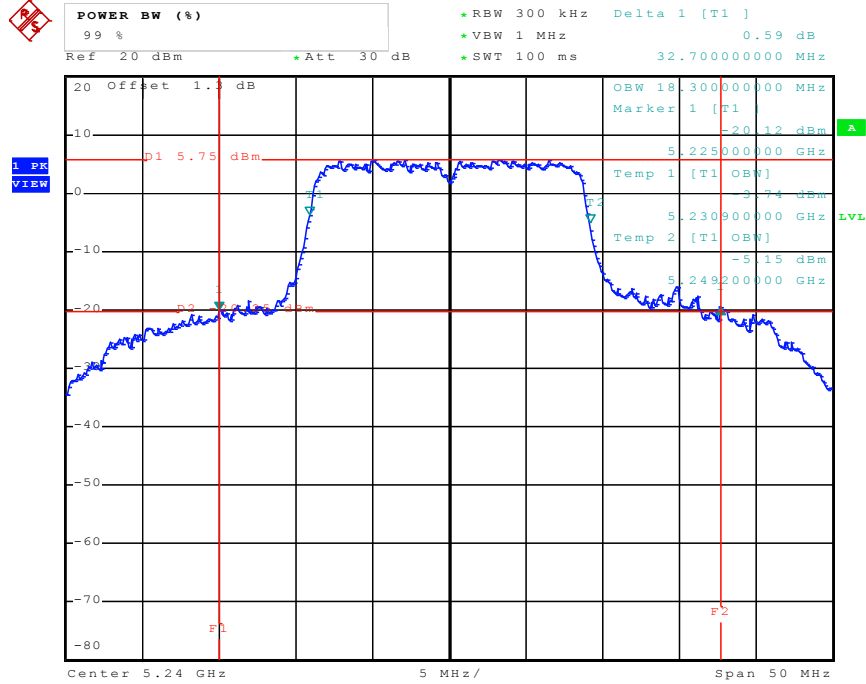

Date: 3.MAY.2011 14:35:40

26 dB Bandwidth Plot on Configuration IEEE 802.11n Ant. A (20MHz) / 5260 MHz

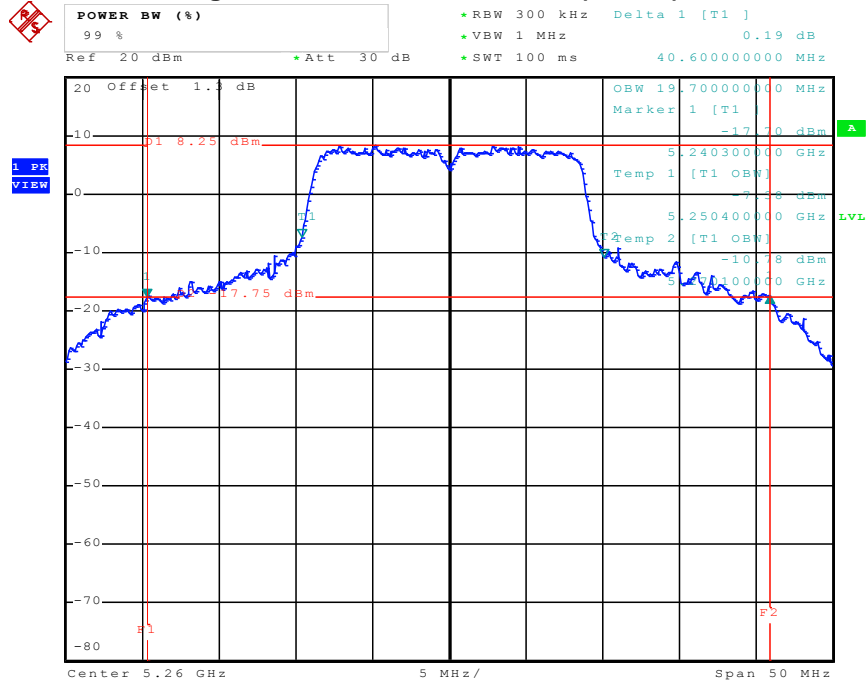

Date: 3.MAY.2011 14:49:27

26 dB Bandwidth Plot on Configuration IEEE 802.11n Ant. A (20MHz) / 5280 MHz

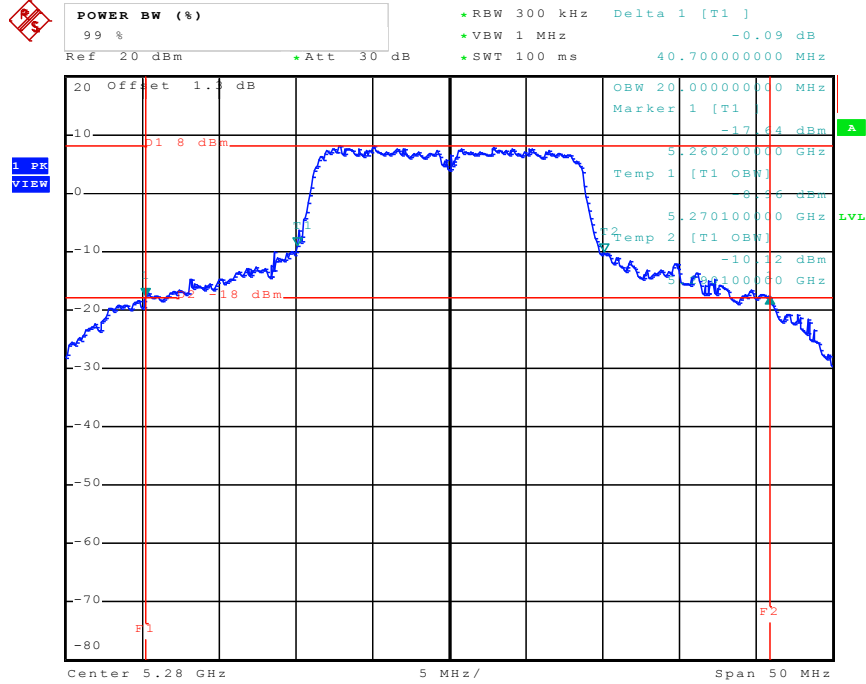

Date: 3.MAY.2011 14:52:09

26 dB Bandwidth Plot on Configuration IEEE 802.11n Ant. A (20MHz) / 5320 MHz

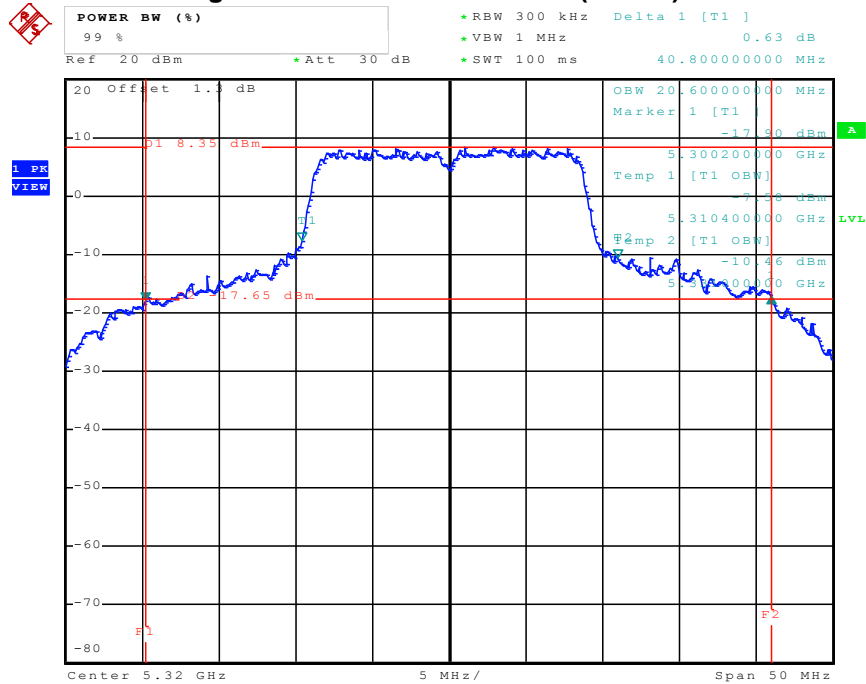

Date: 23.MAY.2011 12:05:48

26 dB Bandwidth Plot on Configuration IEEE 802.11n Ant. A (20MHz) / 5500 MHz

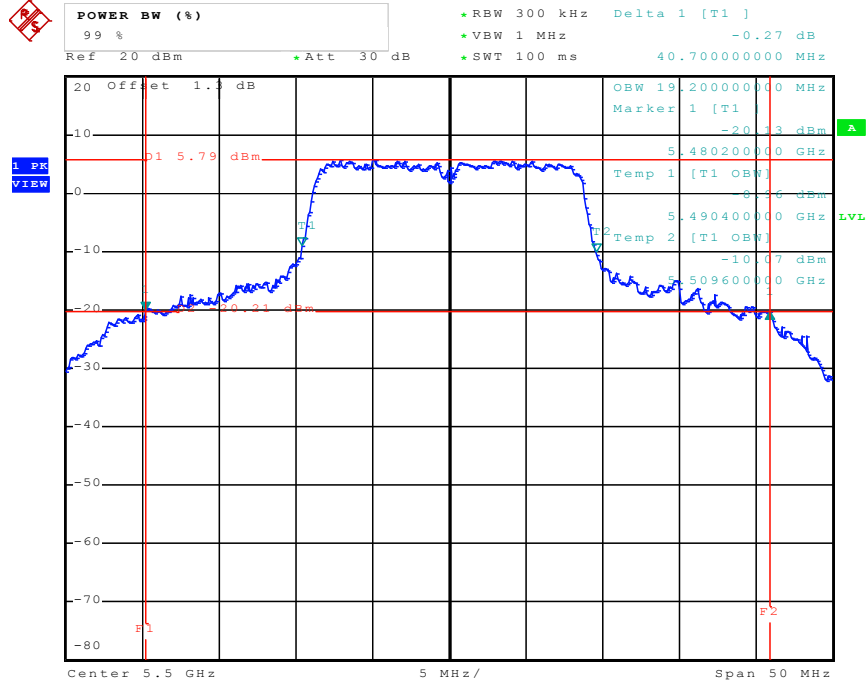

Date: 3.MAY.2011 14:59:40

26 dB Bandwidth Plot on Configuration IEEE 802.11n Ant. A (20MHz) / 5580 MHz

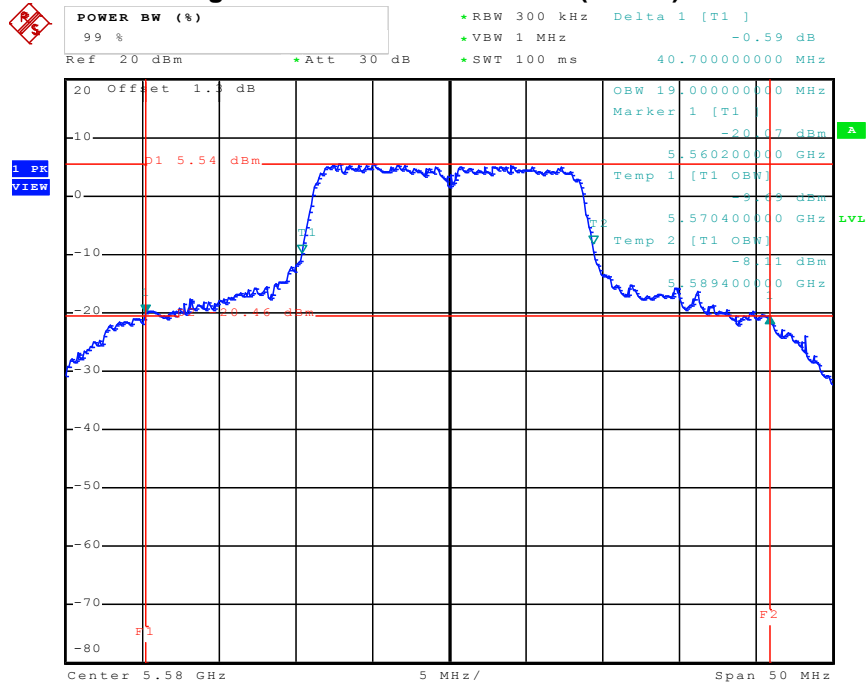

Date: 3.MAY.2011 15:03:27

26 dB Bandwidth Plot on Configuration IEEE 802.11n Ant. A (20MHz) / 5700 MHz

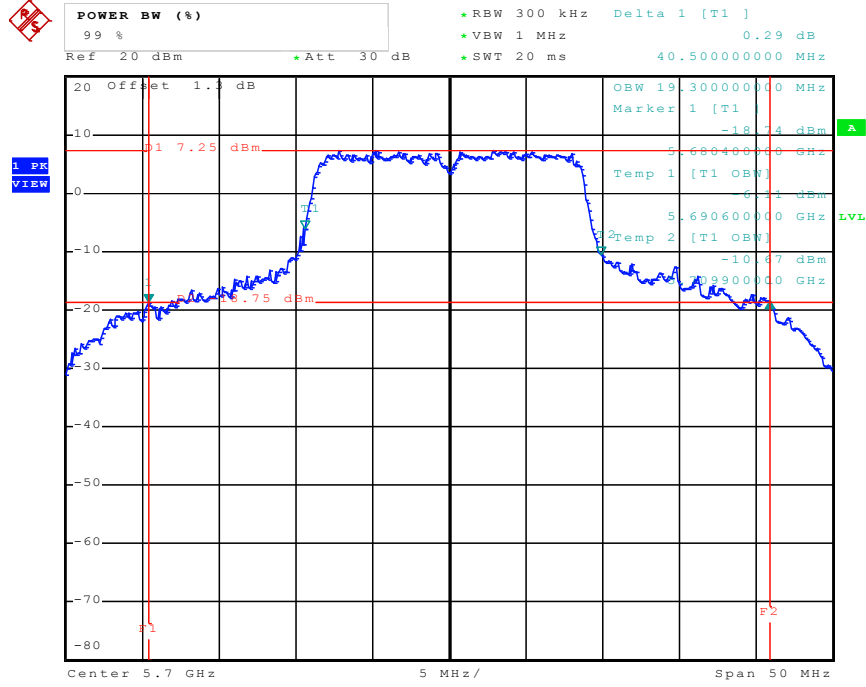

Date: 3.MAY.2011 15:07:14

26 dB Bandwidth Plot on Configuration IEEE 802.11n Ant. A (40MHz) / 5190 MHz

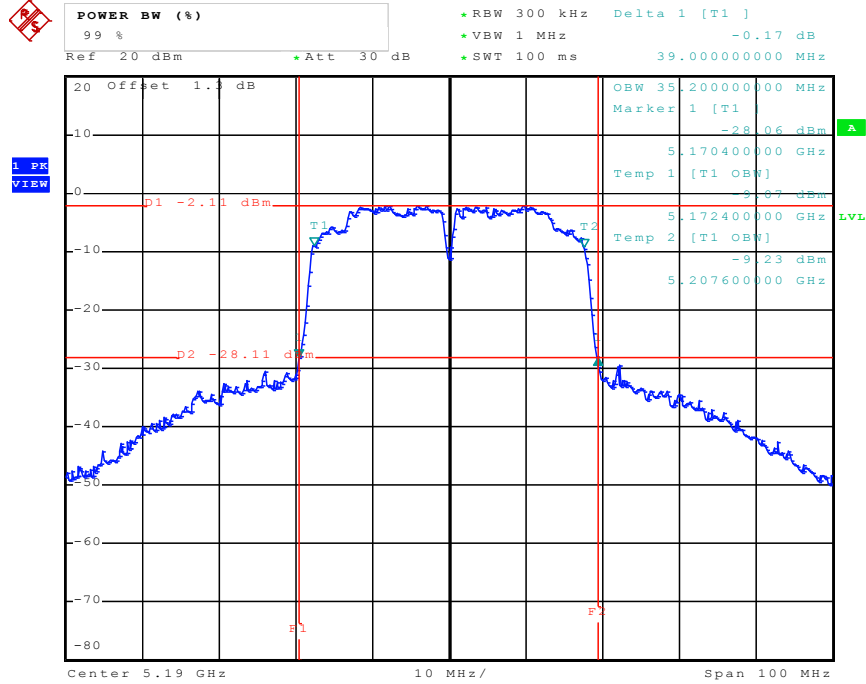

Date: 23.MAY.2011 12:10:48

26 dB Bandwidth Plot on Configuration IEEE 802.11n Ant. A (40MHz) / 5230 MHz

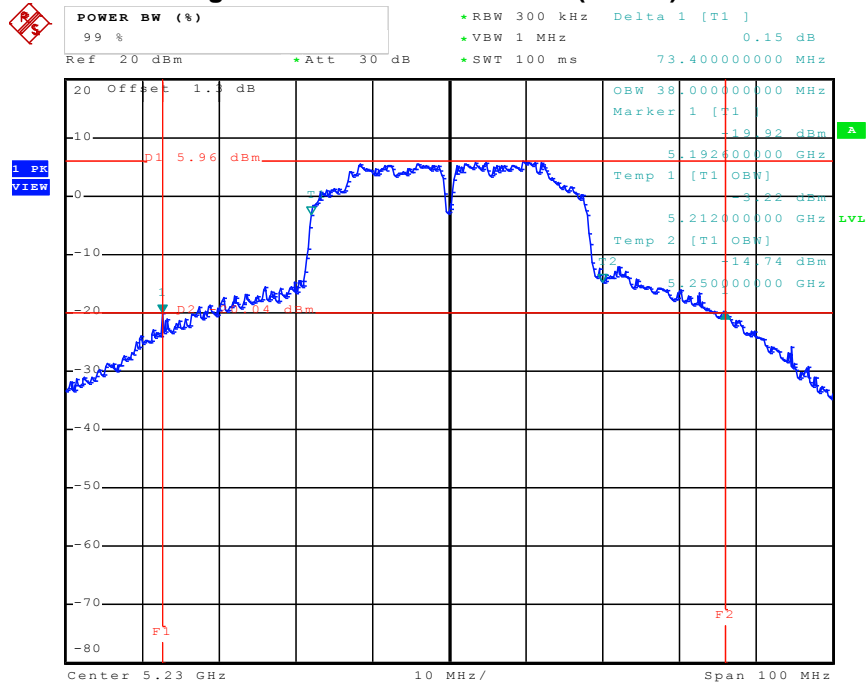

Date: 3.MAY.2011 16:11:24

26 dB Bandwidth Plot on Configuration IEEE 802.11n Ant. A (40MHz) / 5270 MHz

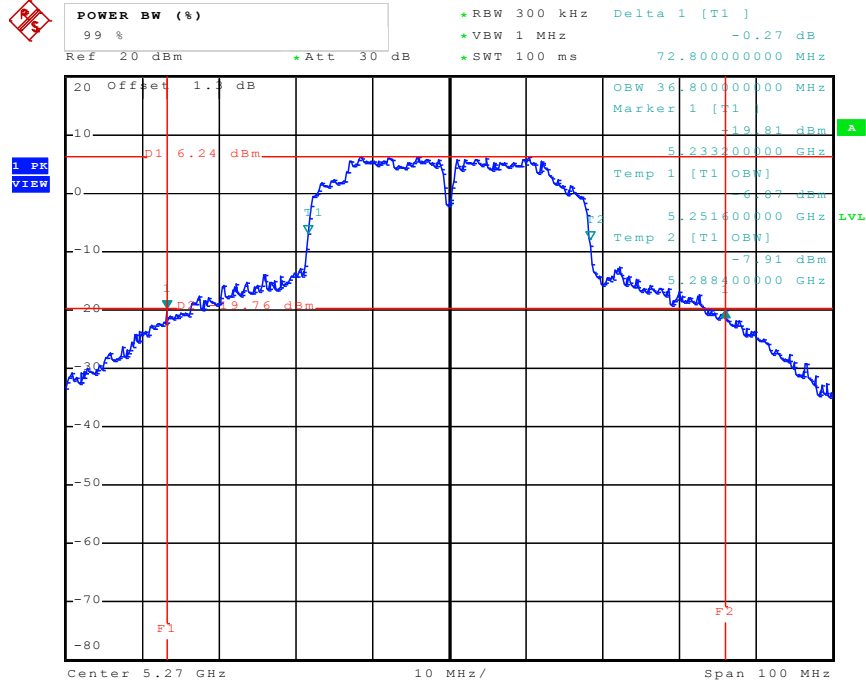

Date: 3.MAY.2011 16:13:57

26 dB Bandwidth Plot on Configuration IEEE 802.11n Ant. A (40MHz) / 5310 MHz

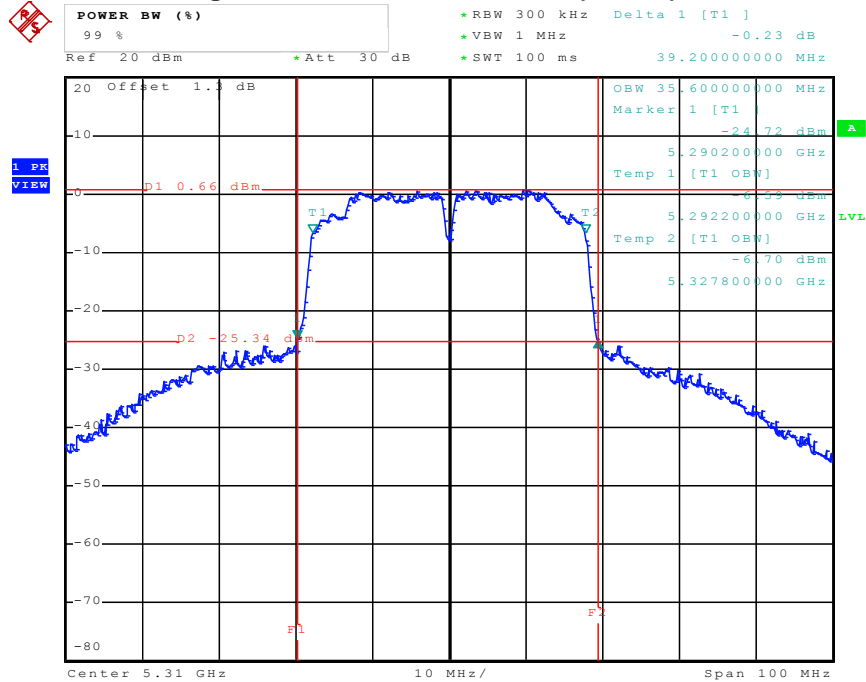

Date: 23.MAY.2011 12:15:05

26 dB Bandwidth Plot on Configuration IEEE 802.11n Ant. A (40MHz) / 5670 MHz

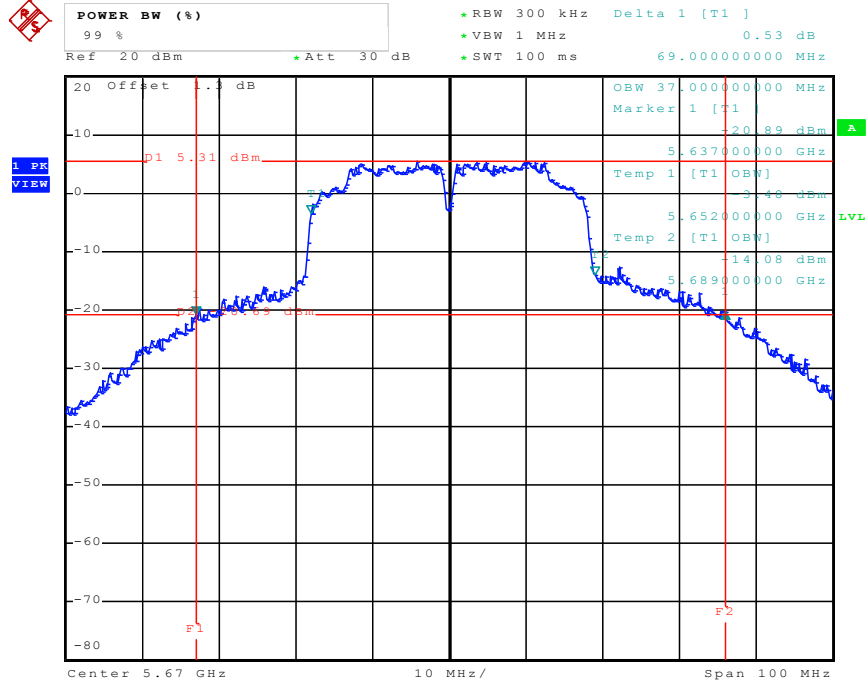

Date: 3.MAY.2011 16:25:19

**For Two Chain:
26 dB Bandwidth Plot on Configuration IEEE 802.11n Ant. A (20MHz) / 5180 MHz**

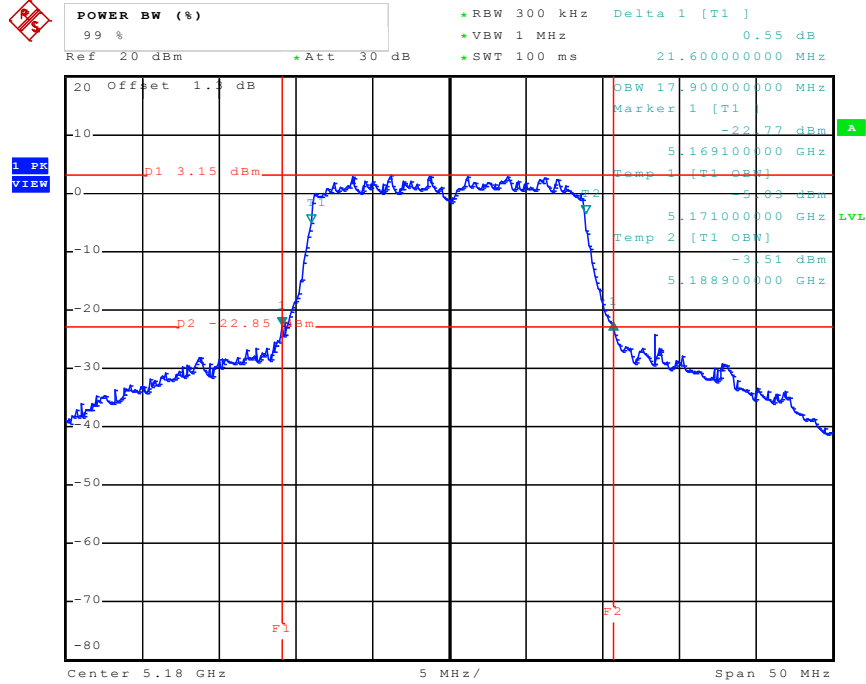

Date: 3.MAY.2011 20:30:28

26 dB Bandwidth Plot on Configuration IEEE 802.11n Ant. A (20MHz) / 5200 MHz

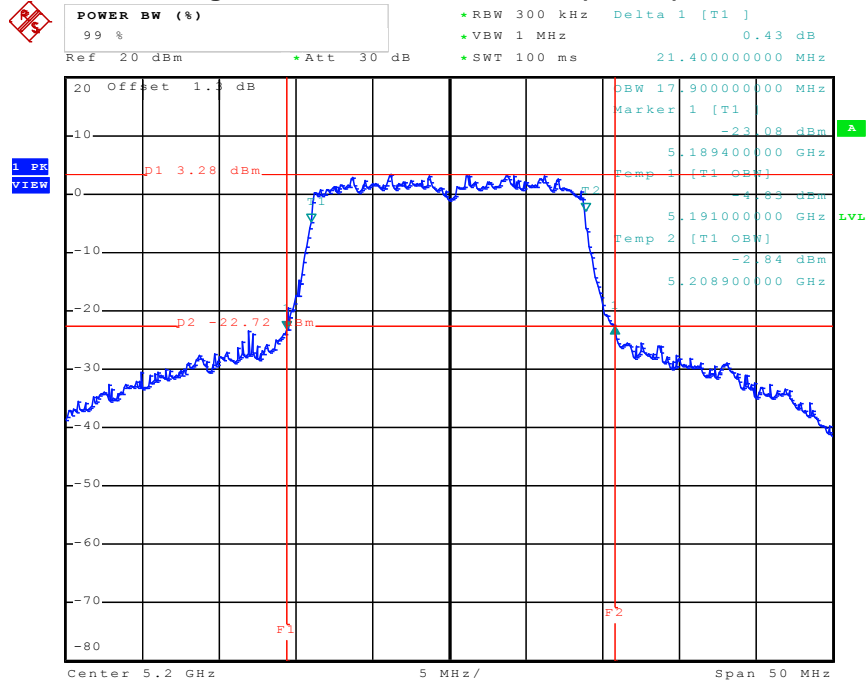

Date: 3.MAY.2011 20:32:47

26 dB Bandwidth Plot on Configuration IEEE 802.11n Ant. A (20MHz) / 5240 MHz

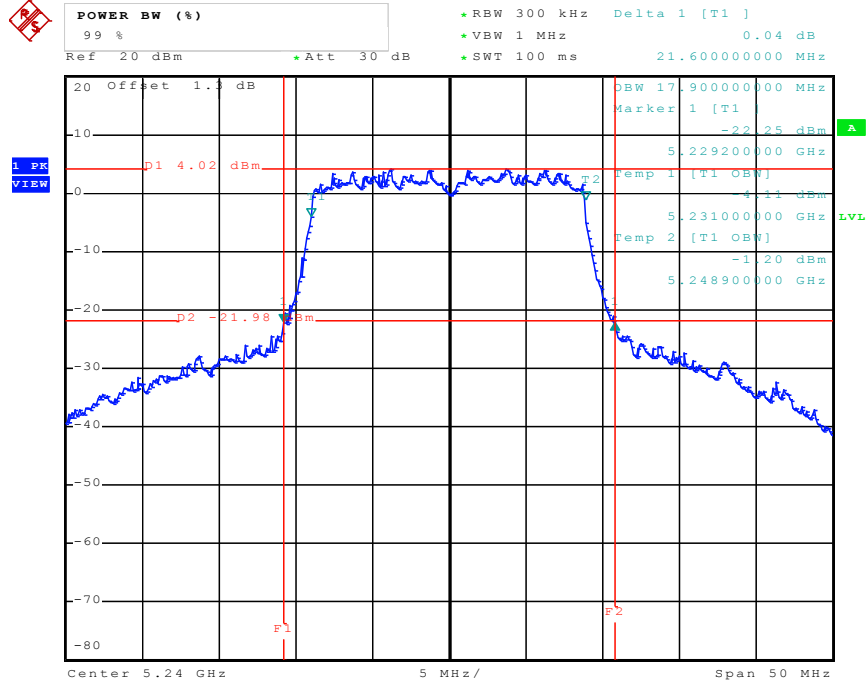

Date: 3.MAY.2011 20:35:04

26 dB Bandwidth Plot on Configuration IEEE 802.11n Ant. A (20MHz) / 5260 MHz

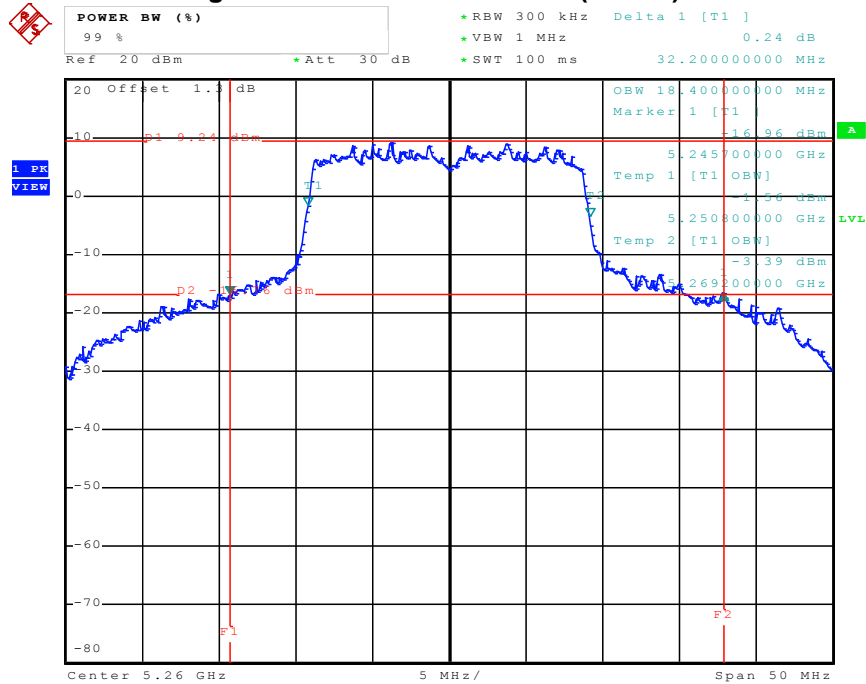

Date: 3.MAY.2011 20:39:23

26 dB Bandwidth Plot on Configuration IEEE 802.11n Ant. A (20MHz) / 5280 MHz

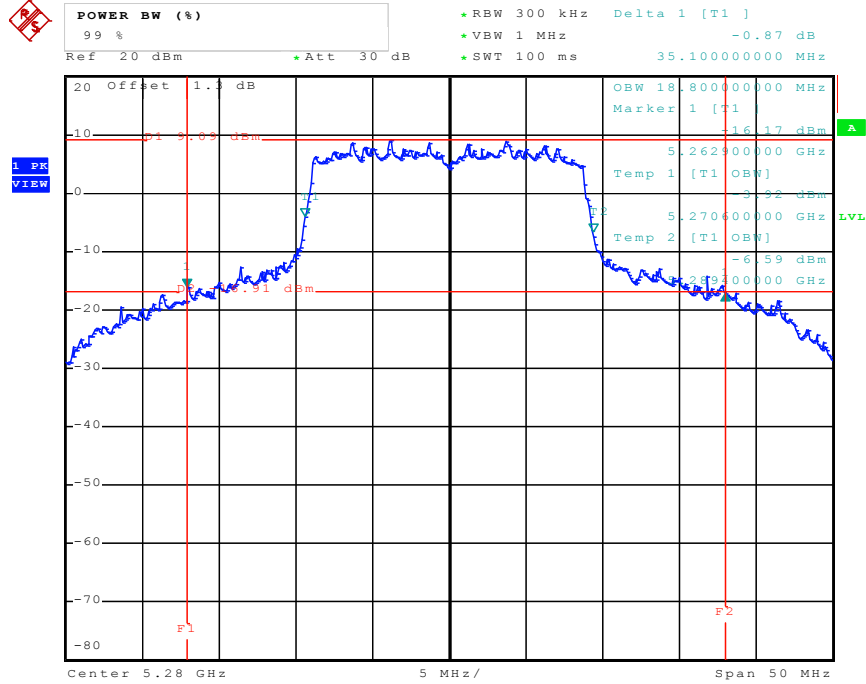

Date: 3.MAY.2011 20:41:51

26 dB Bandwidth Plot on Configuration IEEE 802.11n Ant. A (20MHz) / 5320 MHz

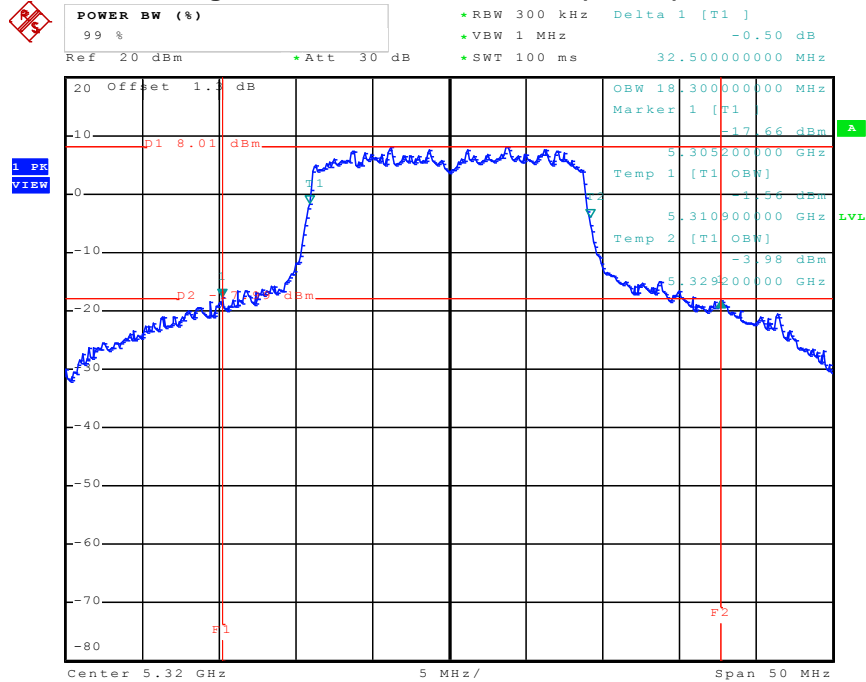

Date: 23.MAY.2011 14:38:30

26 dB Bandwidth Plot on Configuration IEEE 802.11n Ant. A (20MHz) / 5500 MHz

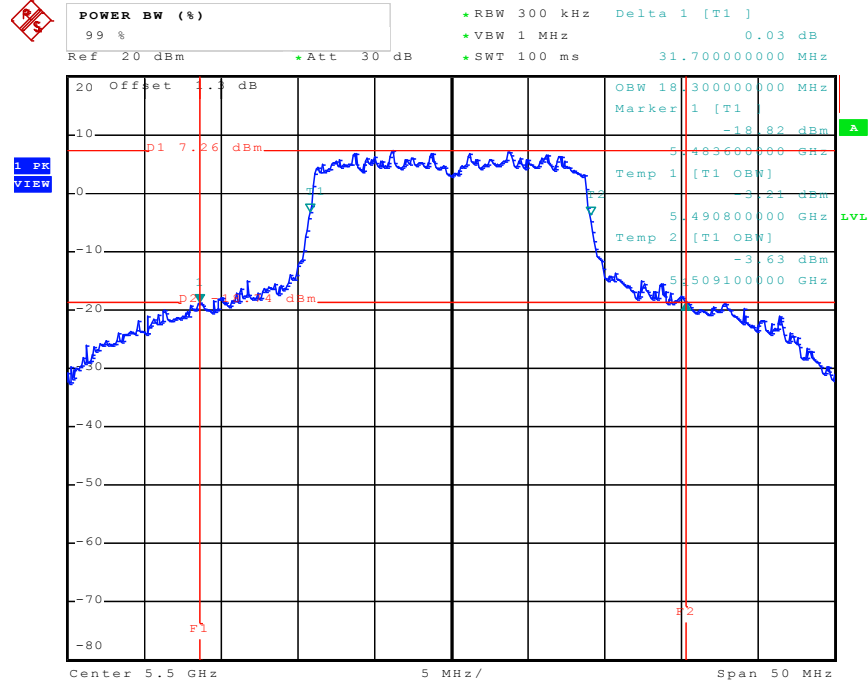

Date: 3.MAY.2011 20:47:40

26 dB Bandwidth Plot on Configuration IEEE 802.11n Ant. A (20MHz) / 5580 MHz

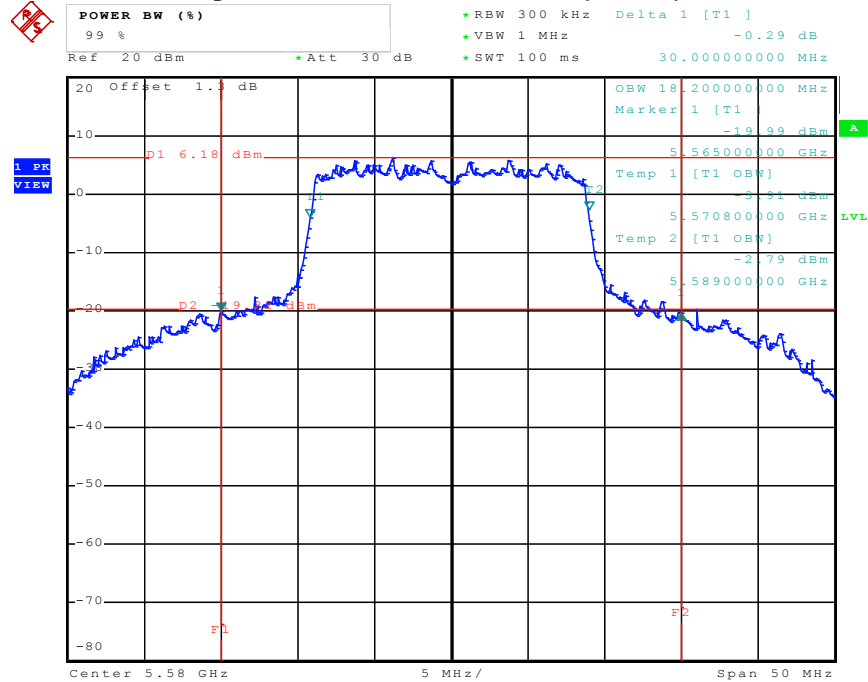

Date: 3.MAY.2011 20:50:32

26 dB Bandwidth Plot on Configuration IEEE 802.11n Ant. A (20MHz) / 5700 MHz

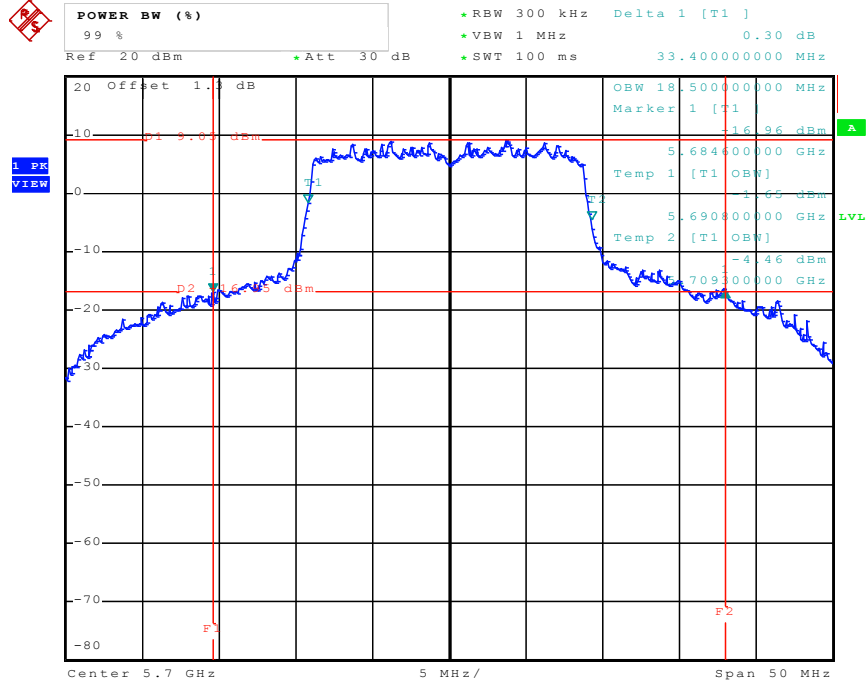

Date: 3.MAY.2011 20:53:09

26 dB Bandwidth Plot on Configuration IEEE 802.11n Ant. B (20MHz) / 5180 MHz

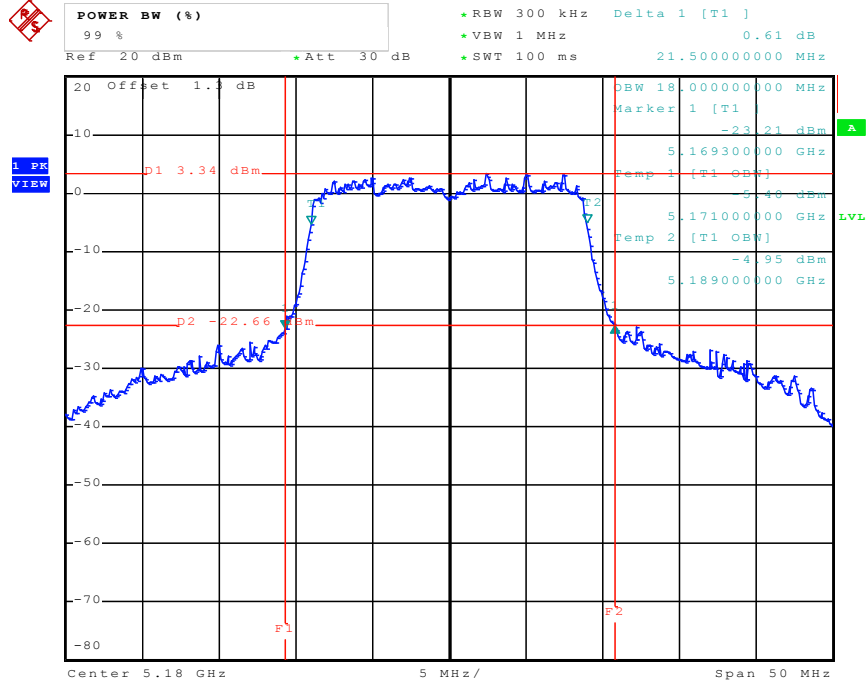

Date: 3.MAY.2011 21:27:01

26 dB Bandwidth Plot on Configuration IEEE 802.11n Ant. B (20MHz) / 5200 MHz

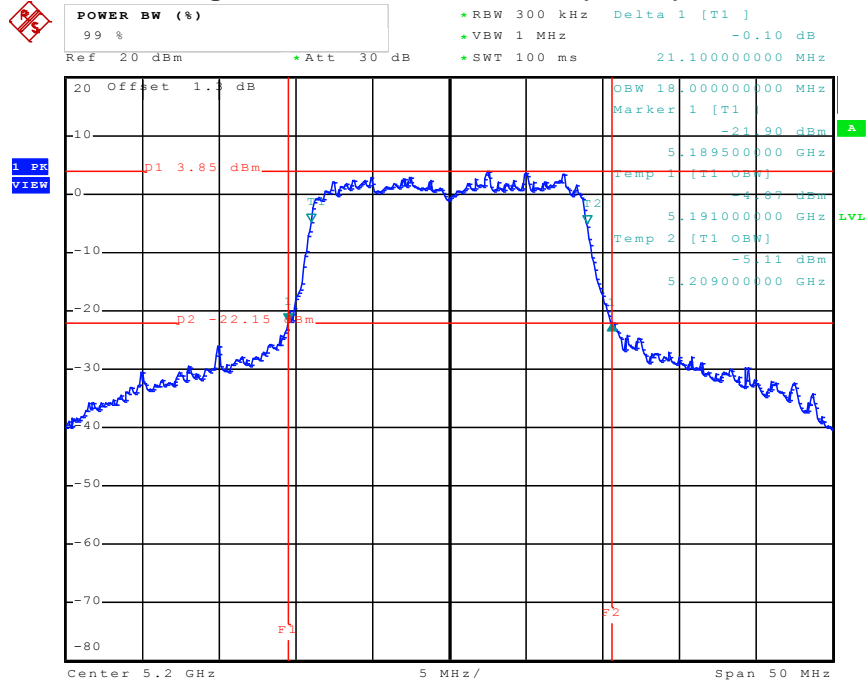

Date: 3.MAY.2011 21:28:59

26 dB Bandwidth Plot on Configuration IEEE 802.11n Ant. B (20MHz) / 5240 MHz

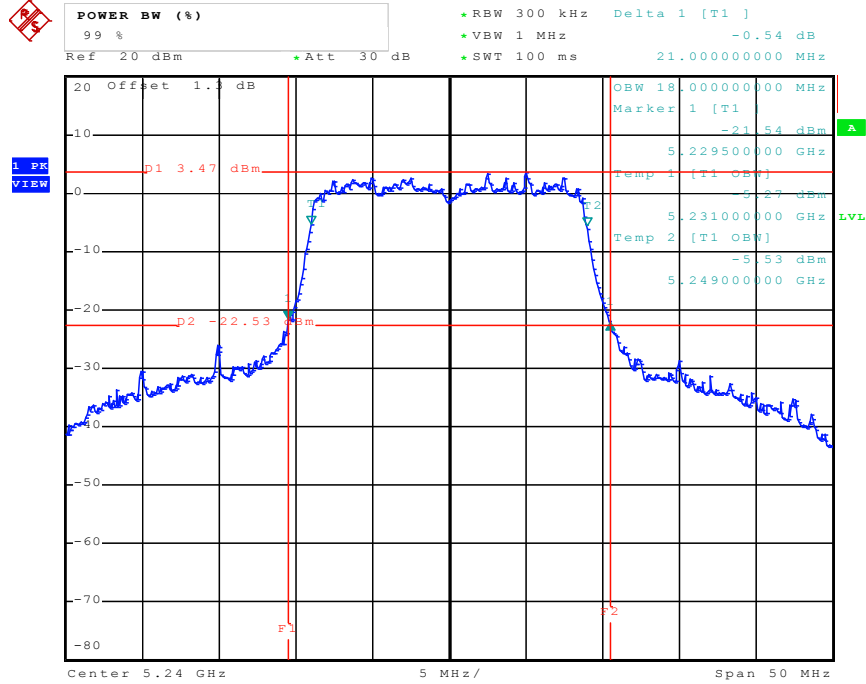

Date: 3.MAY.2011 21:31:18

26 dB Bandwidth Plot on Configuration IEEE 802.11n Ant. B (20MHz) / 5260 MHz

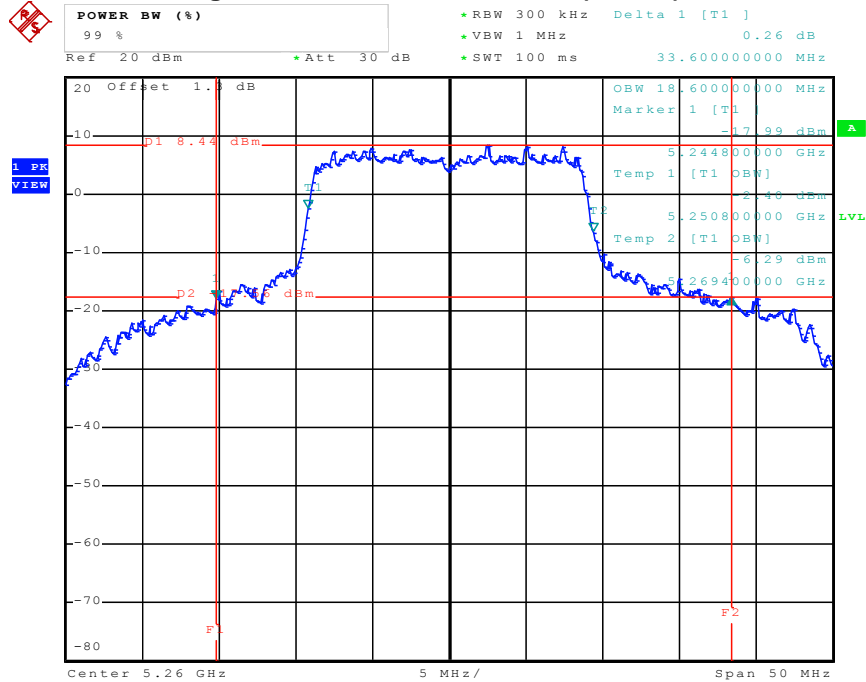

Date: 3.MAY.2011 22:23:23

26 dB Bandwidth Plot on Configuration IEEE 802.11n Ant. B (20MHz) / 5280 MHz

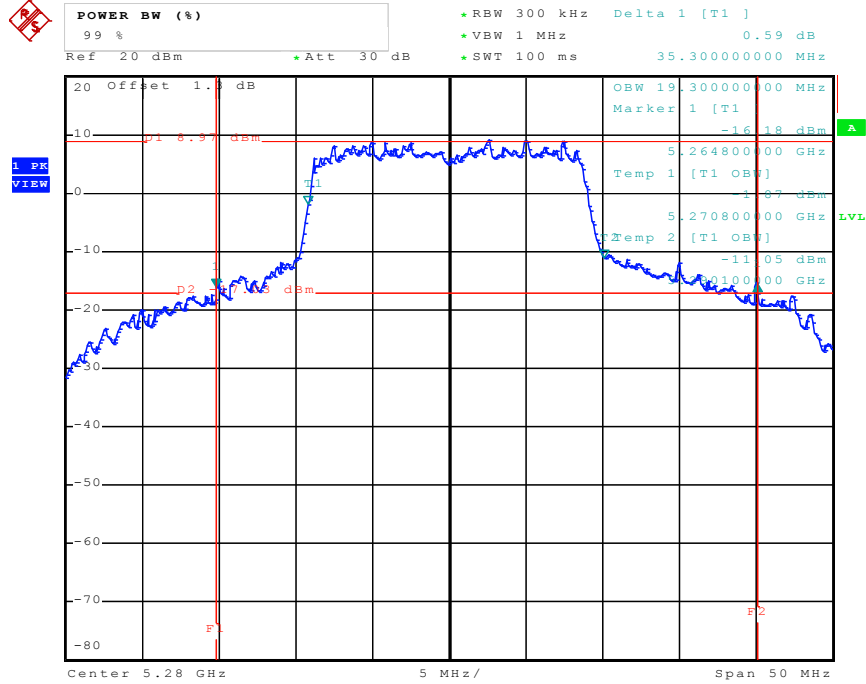

Date: 3.MAY.2011 22:27:34

26 dB Bandwidth Plot on Configuration IEEE 802.11n Ant. B (20MHz) / 5320 MHz

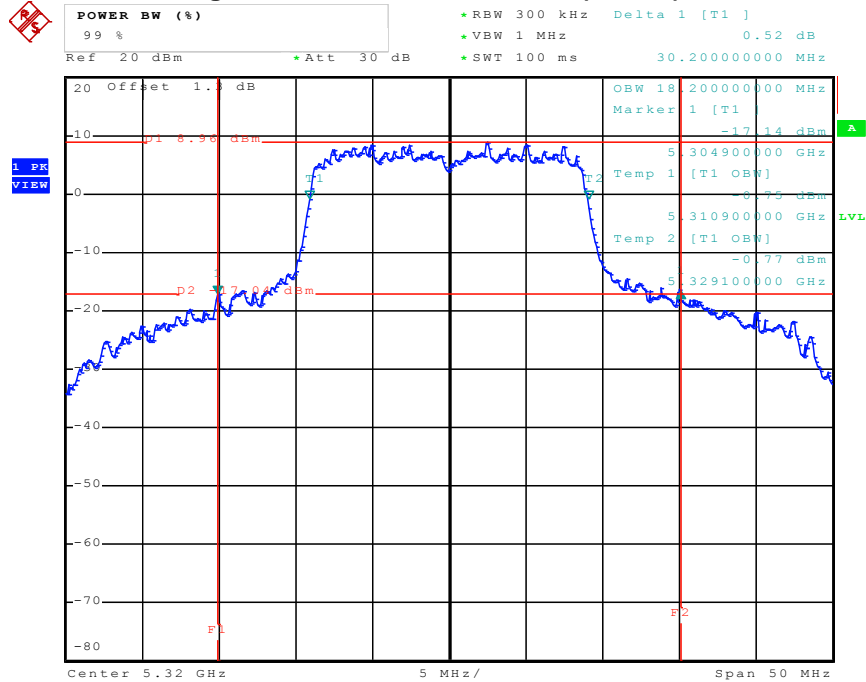

Date: 23.MAY.2011 14:48:03

26 dB Bandwidth Plot on Configuration IEEE 802.11n Ant. B (20MHz) / 5500 MHz

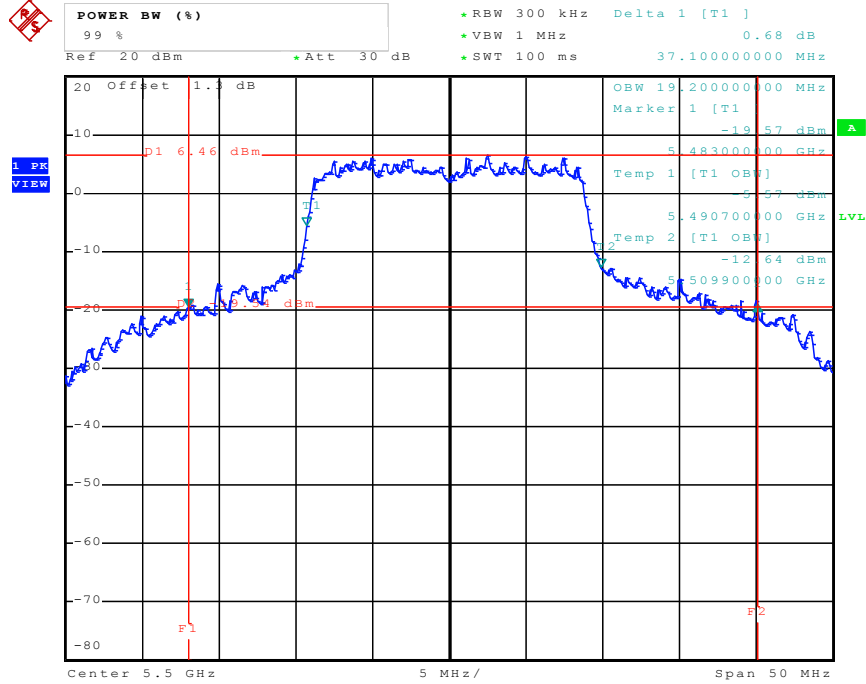

Date: 3.MAY.2011 21:46:22

26 dB Bandwidth Plot on Configuration IEEE 802.11n Ant. B (20MHz) / 5580 MHz

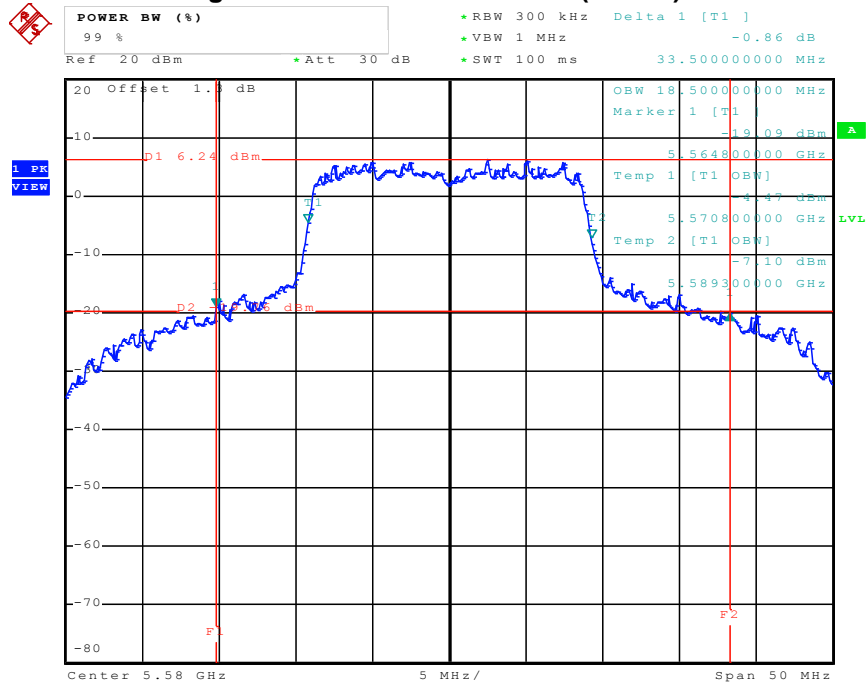

Date: 3.MAY.2011 21:49:16

26 dB Bandwidth Plot on Configuration IEEE 802.11n Ant. B (20MHz) / 5700 MHz

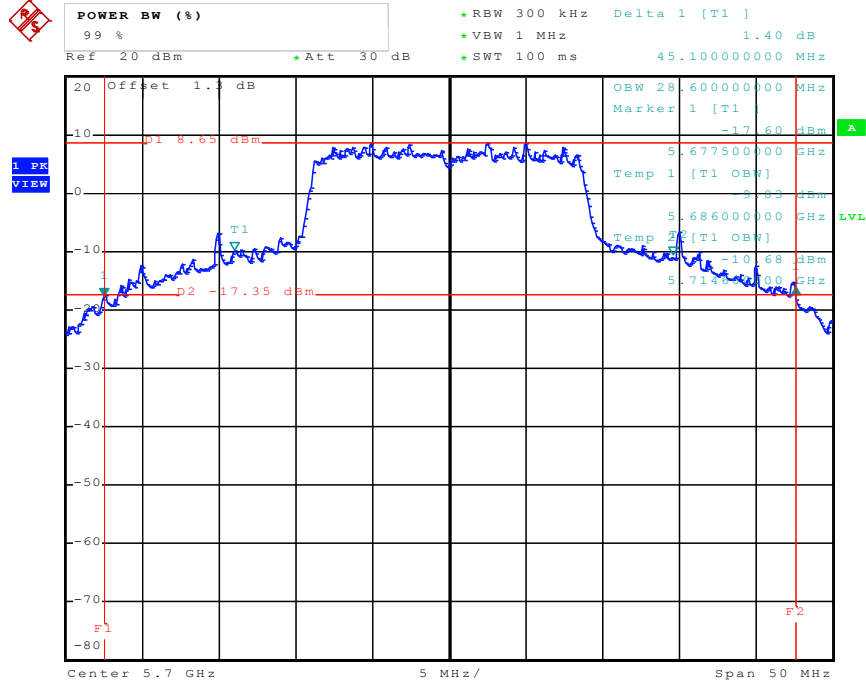

Date: 3.MAY.2011 21:51:36

26 dB Bandwidth Plot on Configuration IEEE 802.11n Ant. A (40MHz) / 5190 MHz

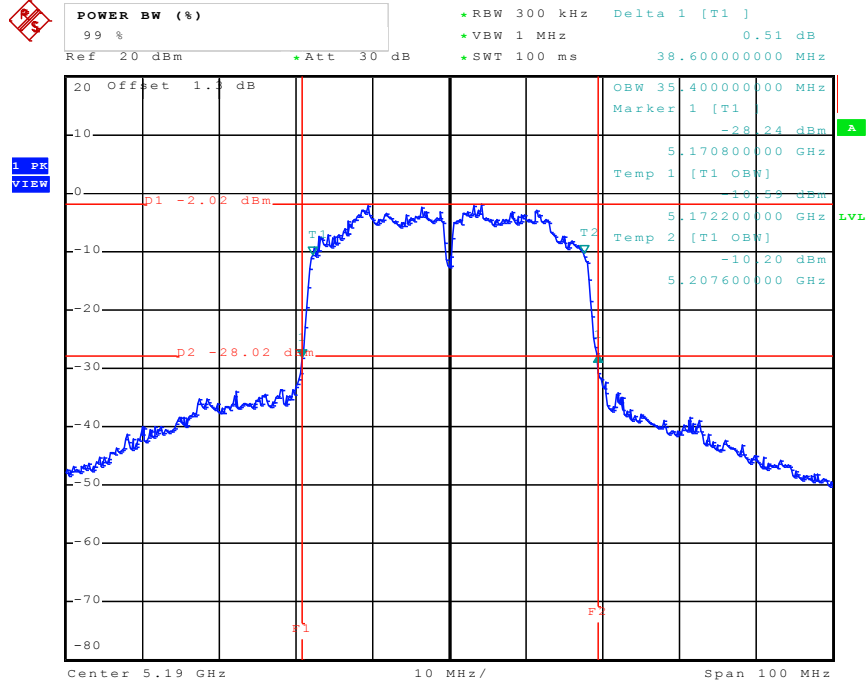

Date: 23.MAY.2011 14:52:43

26 dB Bandwidth Plot on Configuration IEEE 802.11n Ant. A (40MHz) / 5230 MHz

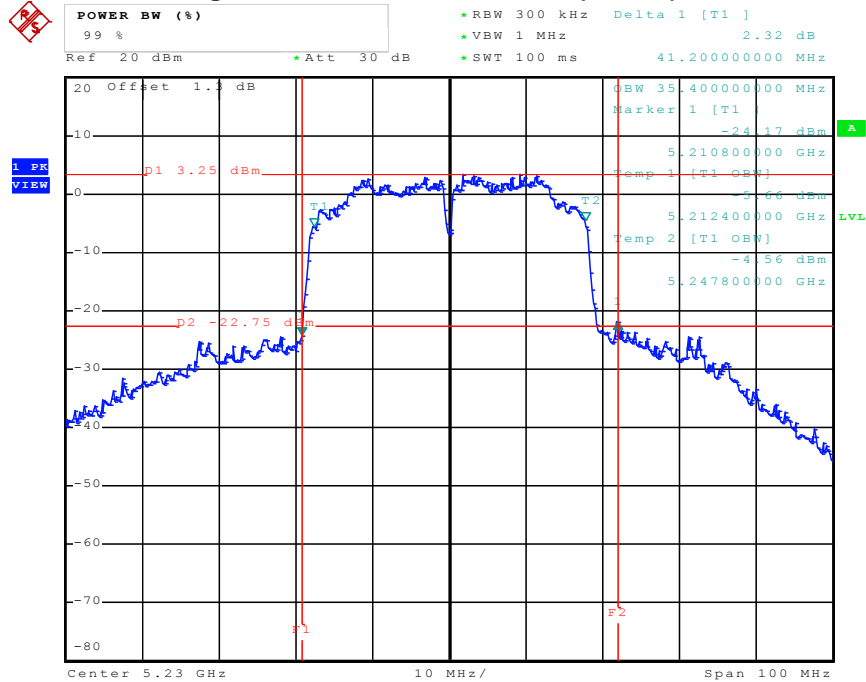

Date: 4.MAY.2011 09:02:56

26 dB Bandwidth Plot on Configuration IEEE 802.11n Ant. A (40MHz) / 5270 MHz

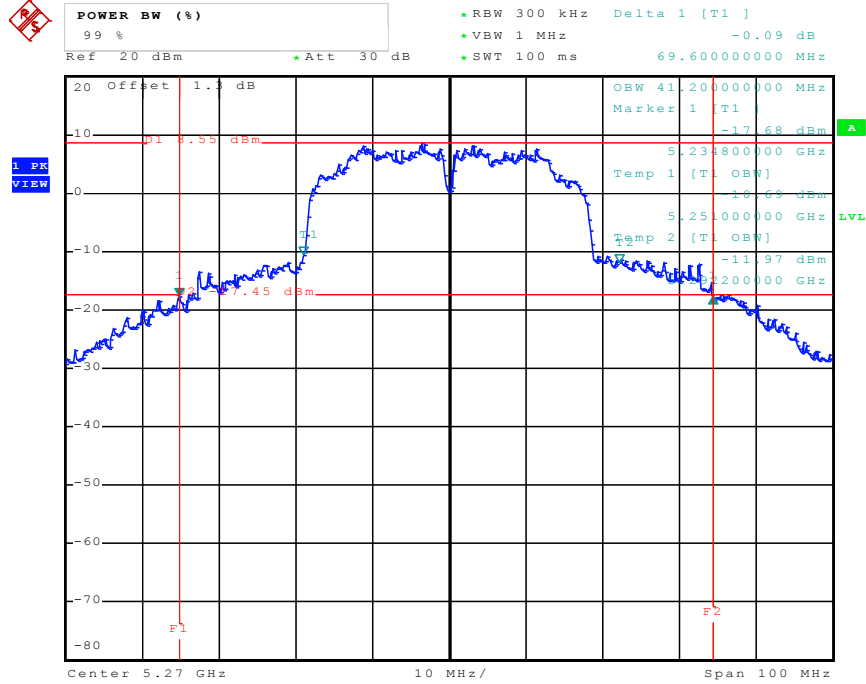

Date: 4.MAY.2011 09:05:57

26 dB Bandwidth Plot on Configuration IEEE 802.11n Ant. A (40MHz) / 5310 MHz

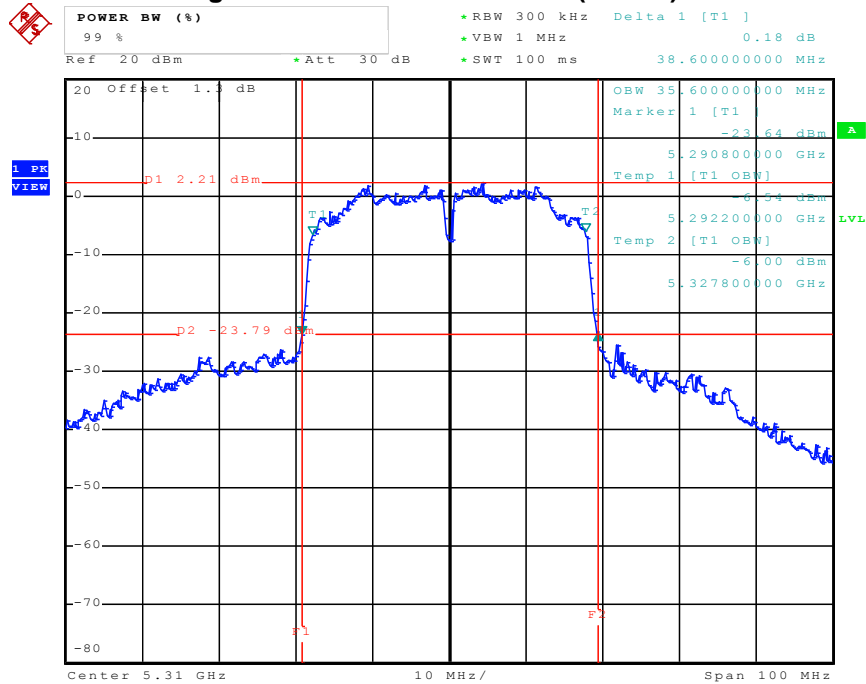

Date: 23.MAY.2011 15:19:36

26 dB Bandwidth Plot on Configuration IEEE 802.11n Ant. A (40MHz) / 5510 MHz

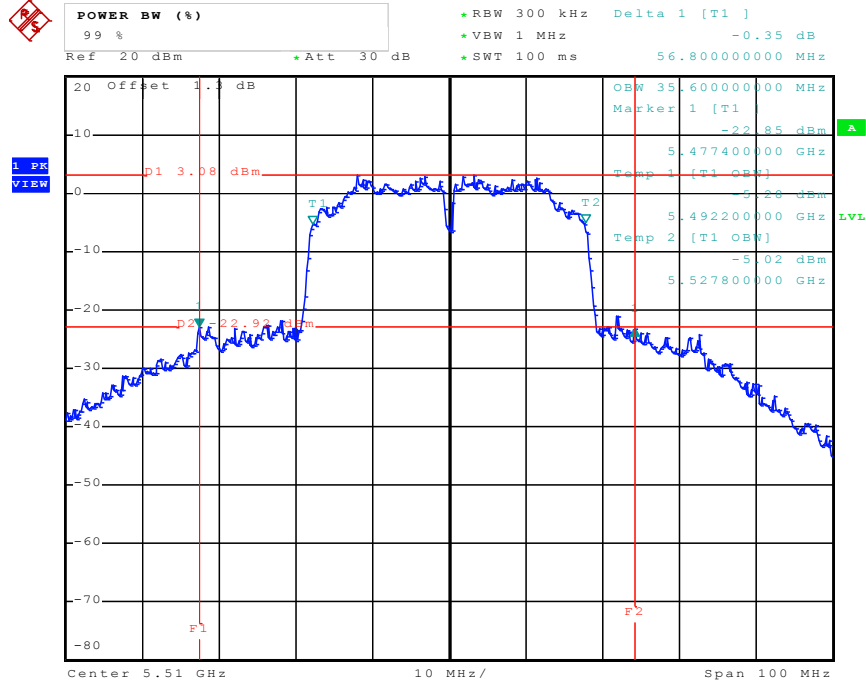

Date: 23.MAY.2011 15:25:34

26 dB Bandwidth Plot on Configuration IEEE 802.11n Ant. A (40MHz) / 5550 MHz

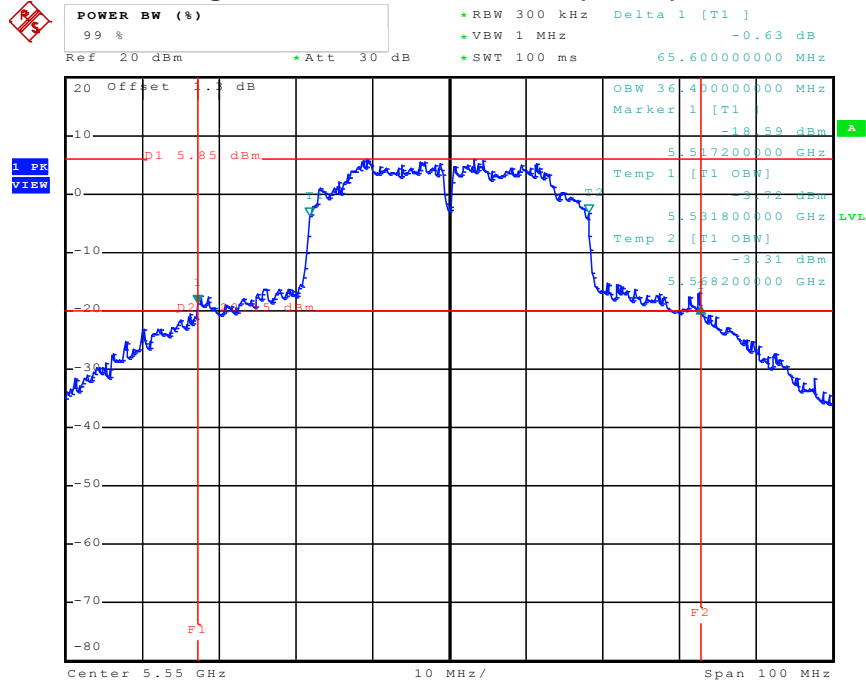

Date: 4.MAY.2011 09:13:47

26 dB Bandwidth Plot on Configuration IEEE 802.11n Ant. A (40MHz) / 5670 MHz

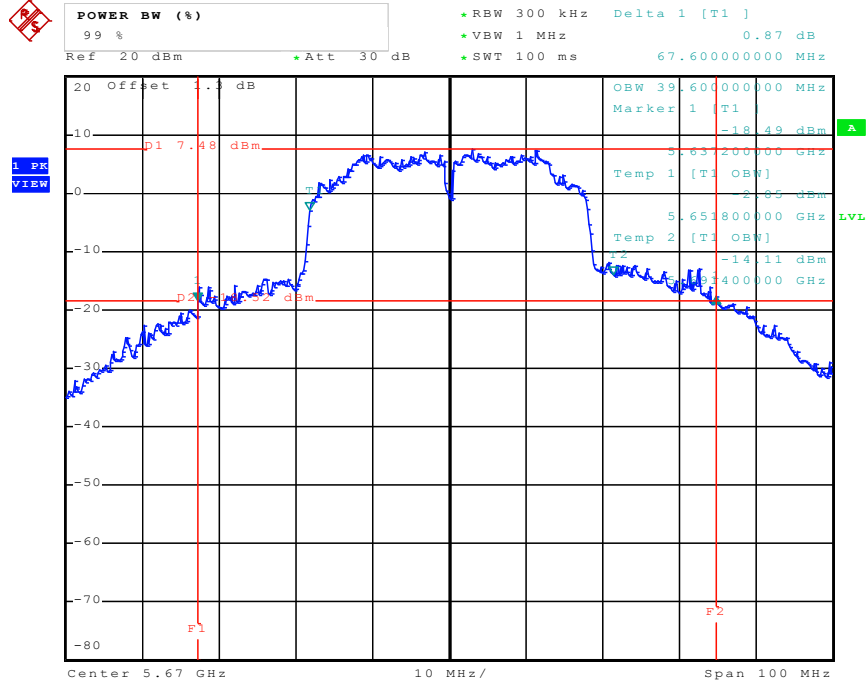

Date: 4.MAY.2011 09:16:31

26 dB Bandwidth Plot on Configuration IEEE 802.11n Ant. B (40MHz) / 5190 MHz

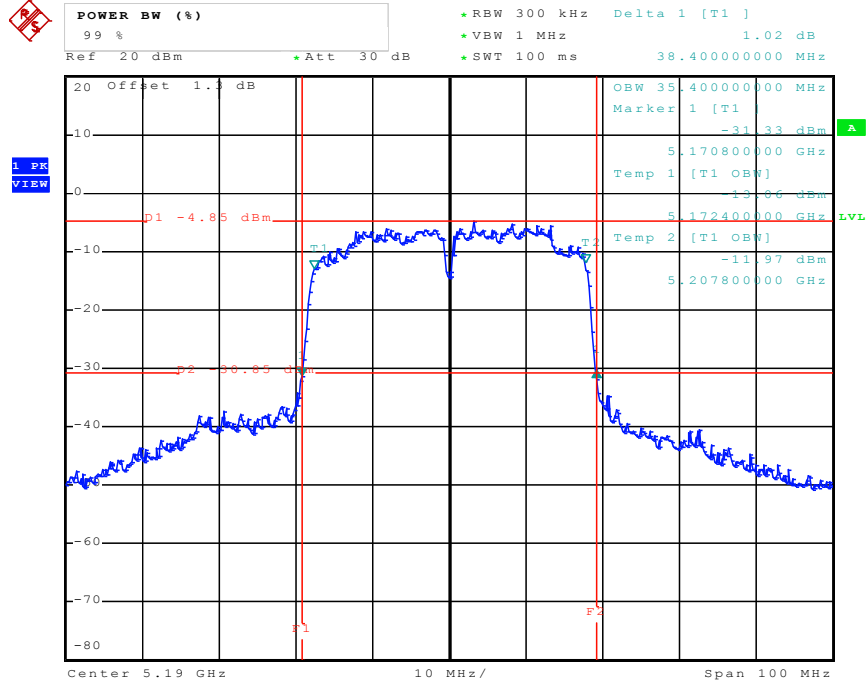

Date: 23.MAY.2011 14:55:08

26 dB Bandwidth Plot on Configuration IEEE 802.11n Ant. B (40MHz) / 5230 MHz

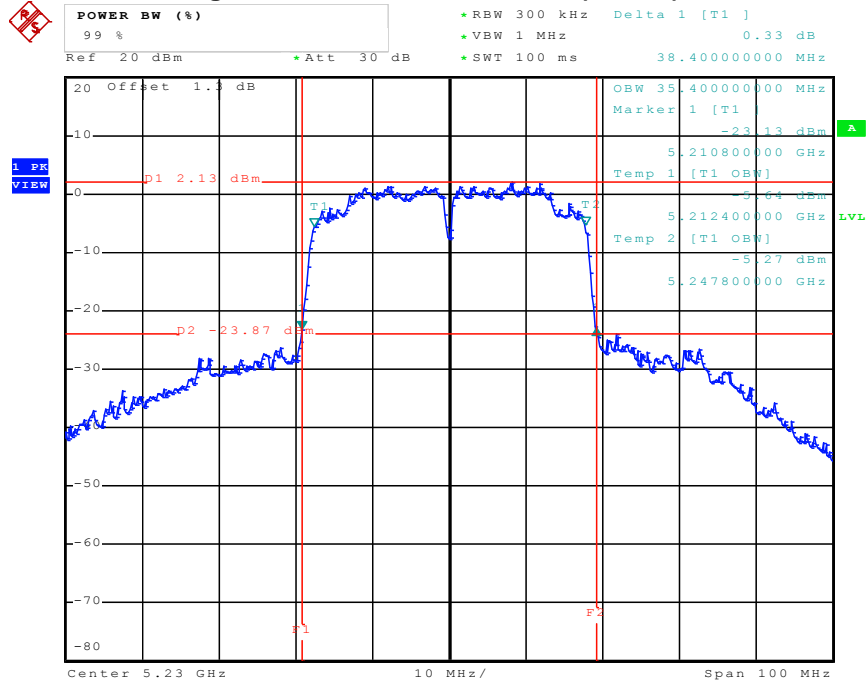

Date: 4.MAY.2011 09:32:43

26 dB Bandwidth Plot on Configuration IEEE 802.11n Ant. B (40MHz) / 5270 MHz

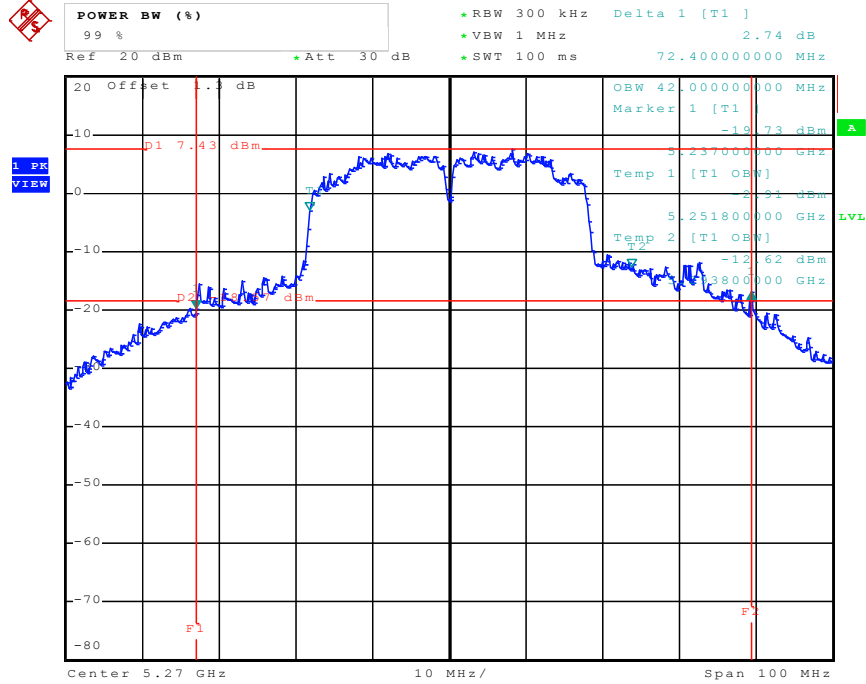

Date: 4.MAY.2011 09:35:22

26 dB Bandwidth Plot on Configuration IEEE 802.11n Ant. B (40MHz) / 5310 MHz

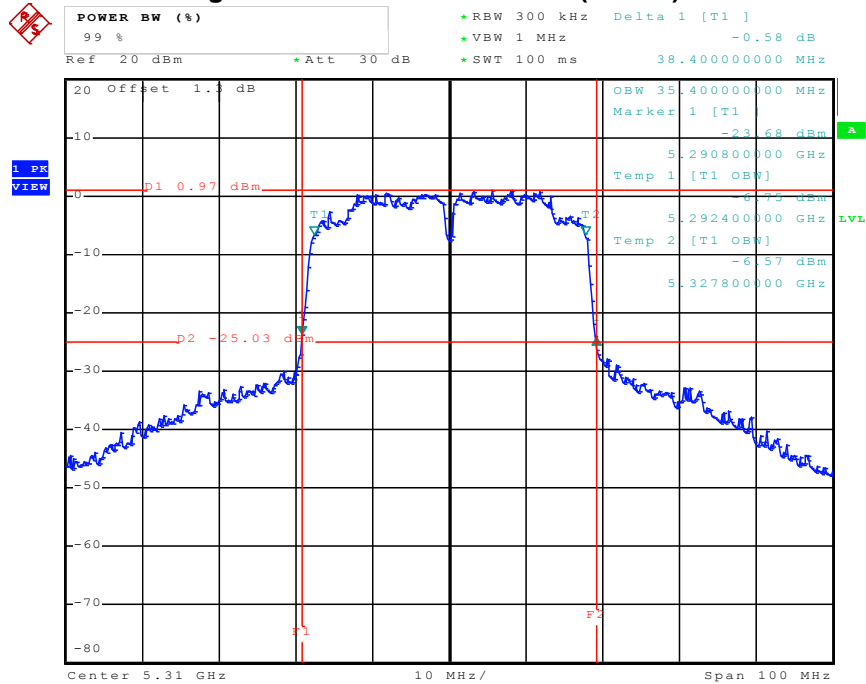

Date: 23.MAY.2011 15:22:22

26 dB Bandwidth Plot on Configuration IEEE 802.11n Ant. B (40MHz) / 5510 MHz

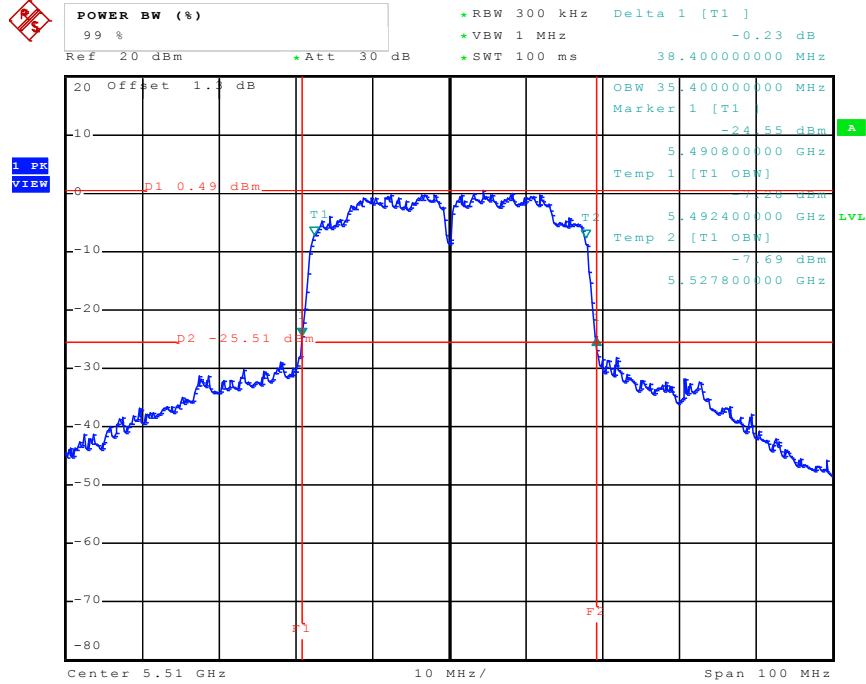

Date: 23.MAY.2011 15:28:44

26 dB Bandwidth Plot on Configuration IEEE 802.11n Ant. B (40MHz) / 5550 MHz

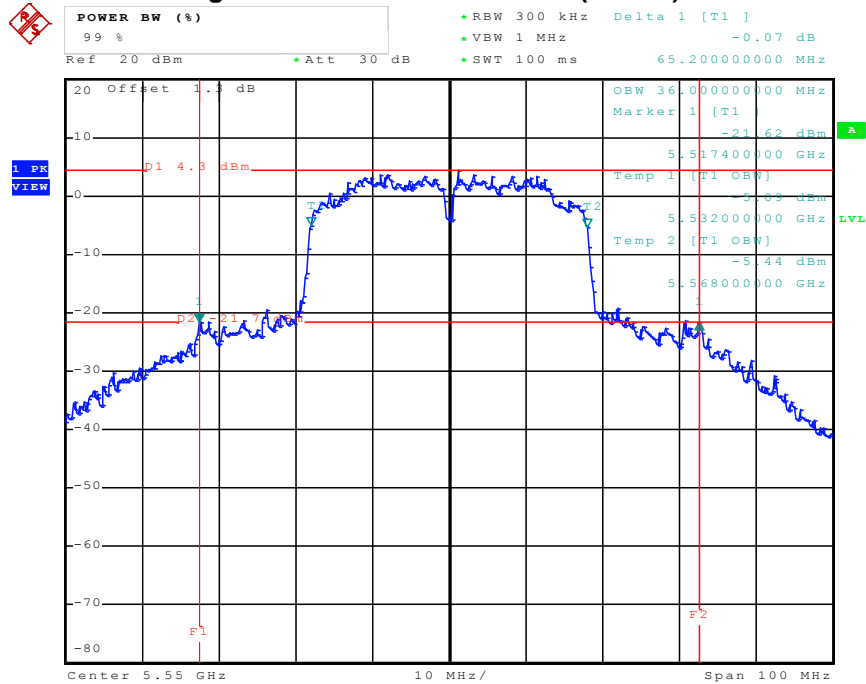

Date: 4.MAY.2011 09:43:41

26 dB Bandwidth Plot on Configuration IEEE 802.11n Ant. B (40MHz) / 5670 MHz

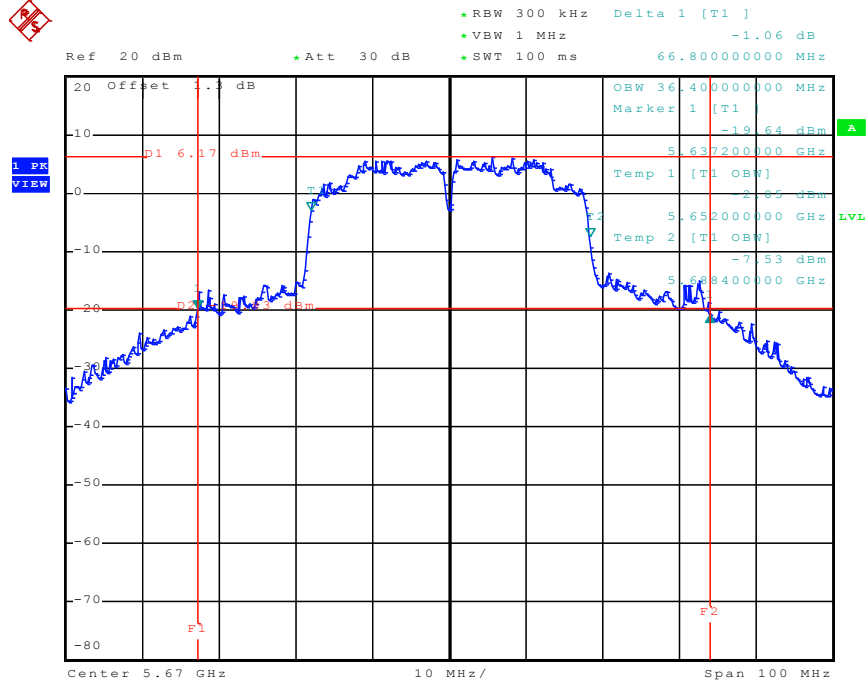

Date: 4.MAY.2011 09:46:35

3.3 Maximum Conducted Output Power Measurement

3.3.1 Limit

For the band 5.15~5.25 GHz, the maximum conducted output power over the frequency band of operation shall not exceed the lesser of 50 mW (17dBm) or 4 dBm + 10log B, where B is the 26 dB emissions bandwidth in MHz. If transmitting antennas of directional gain greater than 6 dBi are used, the peak output power and power density from the intentional radiator shall be reduced by the amount in dB that the directional gain of the antenna exceeds 6 dBi.

For the 5.25-5.35 GHz and 5.47-5.725 GHz bands, the maximum conducted output power over the frequency bands of operation shall not exceed the lesser of 250 mW (24dBm) or 11 dBm + 10log B. If transmitting antennas of directional gain greater than 6 dBi are used, the peak output power and power density from the intentional radiator shall be reduced by the amount in dB that the directional gain of the antenna exceeds 6 dBi.

Maximum Conducted Output Power mean that the total transmit power delivered to all antennas and antenna elements averaged across all symbols in the signaling alphabet when the transmitter is operating at its maximum power control level. Power must be summed across all antennas and antenna elements. The average must not include any time intervals during which the transmitter is off or is transmitting at a reduced power level.

3.3.2 Measuring Instruments and Setting

Please refer to section 4 of equipments list in this report. The following table is the setting of the Power meter.

Power Meter Parameter	Setting
Filter No.	Auto
Measurement time	0.135 s ~ 26 s
Used Sensor	MA2411B

3.3.3 Test Procedures

1. The transmitter output (antenna port) was connected to the wideband power meter.
2. Turn on the EUT and power meter and then record the power value.
3. Repeat above procedures on all channels needed to be tested.

3.3.4 Test Setup Layout

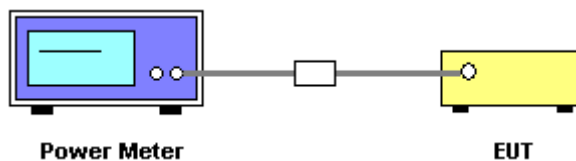

3.3.5 Test Deviation

There is no deviation with the original standard.

3.3.6 EUT Operation during Test

The EUT was programmed to be in continuously transmitting mode.

3.3.7 Test Result of Maximum Conducted Output Power

Final Test Date	May 23, 2011	Test Site No.	TH01-HY
Temperature	27°C	Humidity	62%
Test Engineer	Ian	Configurations	802.11a/n

**For Single Chain:
Configuration of IEEE 802.11a Ant. A**

Channel	Frequency	Conducted Power (dBm)	Max. Limit (dBm)	Result
36	5180 MHz	14.43	17.00	Complies
40	5200 MHz	14.32	17.00	Complies
48	5240 MHz	13.19	17.00	Complies
52	5260 MHz	16.03	24.00	Complies
56	5280 MHz	16.18	24.00	Complies
64	5320 MHz	15.32	24.00	Complies
100	5500 MHz	15.17	24.00	Complies
116	5580 MHz	16.08	24.00	Complies
140	5700 MHz	16.03	24.00	Complies

Configuration IEEE 802.11n (20MHz) Ant. A

Channel	Frequency	Conducted Power (dBm)	Max. Limit (dBm)	Result
36	5180 MHz	14.23	17.00	Complies
40	5200 MHz	14.15	17.00	Complies
48	5240 MHz	14.23	17.00	Complies
52	5260 MHz	16.12	24.00	Complies
56	5280 MHz	15.99	24.00	Complies
64	5320 MHz	15.65	24.00	Complies
100	5500 MHz	16.11	24.00	Complies
116	5580 MHz	16.16	24.00	Complies
140	5700 MHz	16.05	24.00	Complies

Configuration IEEE 802.11n (40MHz) Ant. A

Channel	Frequency	Conducted Power (dBm)	Max. Limit (dBm)	Result
38	5190 MHz	9.99	17.00	Complies
46	5230 MHz	16.51	17.00	Complies
54	5270 MHz	16.12	24.00	Complies
62	5310 MHz	10.77	24.00	Complies
102	5510 MHz	16.09	24.00	Complies
110	5550 MHz	16.31	24.00	Complies
134	5670 MHz	16.14	24.00	Complies

**For Two Chain:
Configuration IEEE 802.11n (20MHz) Ant. A**

Channel	Frequency	Conducted Power (dBm)	Max. Limit (dBm)	Result
36	5180 MHz	14.23	17.00	Complies
40	5200 MHz	14.15	17.00	Complies
48	5240 MHz	14.23	17.00	Complies
52	5260 MHz	16.12	24.00	Complies
56	5280 MHz	15.99	24.00	Complies
64	5320 MHz	15.65	24.00	Complies
100	5500 MHz	16.11	24.00	Complies
116	5580 MHz	16.16	24.00	Complies
140	5700 MHz	16.05	24.00	Complies

Configuration IEEE 802.11n (20MHz) Ant. B

Channel	Frequency	Conducted Power (dBm)	Max. Limit (dBm)	Result
36	5180 MHz	11.26	17.00	Complies
40	5200 MHz	10.87	17.00	Complies
48	5240 MHz	9.58	17.00	Complies
52	5260 MHz	14.65	24.00	Complies
56	5280 MHz	16.32	24.00	Complies
64	5320 MHz	15.15	24.00	Complies
100	5500 MHz	16.24	24.00	Complies
116	5580 MHz	16.29	24.00	Complies
140	5700 MHz	16.13	24.00	Complies

Configuration IEEE 802.11n (20MHz) Ant. A+Ant. B

Channel	Frequency	Conducted Power (dBm)	Max. Limit (dBm)	Result
36	5180 MHz	14.20	17.00	Complies
40	5200 MHz	13.98	17.00	Complies
48	5240 MHz	13.05	17.00	Complies
52	5260 MHz	18.49	24.00	Complies
56	5280 MHz	19.25	24.00	Complies
64	5320 MHz	17.91	24.00	Complies
100	5500 MHz	19.28	24.00	Complies
116	5580 MHz	19.20	24.00	Complies
140	5700 MHz	19.19	24.00	Complies

Configuration IEEE 802.11n (40MHz) Ant. A

Channel	Frequency	Conducted Power (dBm)	Max. Limit (dBm)	Result
38	5190 MHz	7.31	17.00	Complies
46	5230 MHz	11.53	17.00	Complies
54	5270 MHz	16.23	24.00	Complies
62	5310 MHz	10.31	24.00	Complies
102	5510 MHz	12.45	24.00	Complies
110	5550 MHz	16.47	24.00	Complies
134	5670 MHz	16.32	24.00	Complies

Configuration IEEE 802.11n (40MHz) Ant. B

Channel	Frequency	Conducted Power (dBm)	Max. Limit (dBm)	Result
38	5190 MHz	5.64	17.00	Complies
46	5230 MHz	11.87	17.00	Complies
54	5270 MHz	16.28	24.00	Complies
62	5310 MHz	9.61	24.00	Complies
102	5510 MHz	10.98	24.00	Complies
110	5550 MHz	14.86	24.00	Complies
134	5670 MHz	16.15	24.00	Complies

Configuration IEEE 802.11n (40MHz) Ant. A+Ant. B

Channel	Frequency	Conducted Power (dBm)	Max. Limit (dBm)	Result
38	5190 MHz	9.57	17.00	Complies
46	5230 MHz	14.71	17.00	Complies
54	5270 MHz	19.27	24.00	Complies
62	5310 MHz	12.98	24.00	Complies
102	5510 MHz	14.79	24.00	Complies
110	5550 MHz	18.75	24.00	Complies
134	5670 MHz	19.25	24.00	Complies

3.4 Power Spectral Density Measurement

3.4.1 Limit

The power spectral density is defined as the highest level of power in dBm per MHz generated by the transmitter within the power envelope. The following table is power spectral density limits and decrease power density limit rule refer to section 3.3.1.

Frequency Range	Power Spectral Density limit (dBm/MHz)
5.15~5.25 GHz	4
5.25-5.35 GHz	11
5.725-5.825	17

3.4.2 Measuring Instruments and Setting

Please refer to section 4 of equipments list in this report. The following table is the setting of the spectrum analyzer.

Spectrum Parameter	Setting
Attenuation	Auto
Span Frequency	Encompass the entire emissions bandwidth (EBW) of the signal
RB	1000 kHz
VB	3000 kHz
Detector	Peak
Trace	Max Hold
Sweep Time	Auto

3.4.3 Test Procedures

1. The transmitter output (antenna port) was connected to the spectrum analyzer.
2. Set RBW of spectrum analyzer to 1000kHz and VBW to 3000kHz. Set Detector to Peak, Trace to Max Hold. Mark the frequency with maximum peak power as the center of the display of the spectrum.

3.4.4 Test Setup Layout

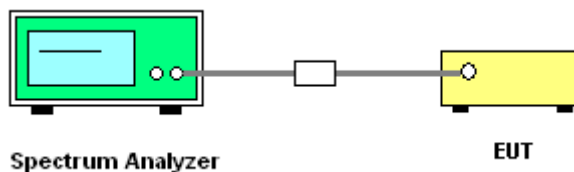

3.4.5 Test Deviation

There is no deviation with the original standard.

3.4.6 EUT Operation during Test

The EUT was programmed to be in continuously transmitting mode.

3.4.7 Test Result of Power Spectral Density

Final Test Date	May 23, 2011	Test Site No.	TH01-HY
Temperature	27°C	Humidity	62%
Test Engineer	Ian	Configurations	802.11a/n

**For Single Chain:
Configuration of IEEE 802.11a Ant. A**

Frequency	Power Density (dBm)	Max. Limit (dBm)	Result
5180 MHz	2.29	4.00	Complies
5200 MHz	3.51	4.00	Complies
5240 MHz	3.42	4.00	Complies
5260 MHz	6.77	11.00	Complies
5280 MHz	6.71	11.00	Complies
5320 MHz	5.24	11.00	Complies
5500 MHz	4.37	11.00	Complies
5580 MHz	3.27	11.00	Complies
5700 MHz	5.68	11.00	Complies

Configuration IEEE 802.11n (20MHz) Ant. A

Frequency	Power Density (dBm)	Max. Limit (dBm)	Result
5180 MHz	2.35	4.00	Complies
5200 MHz	3.87	4.00	Complies
5240 MHz	3.76	4.00	Complies
5260 MHz	7.00	11.00	Complies
5280 MHz	6.29	11.00	Complies
5320 MHz	5.91	11.00	Complies
5500 MHz	3.95	11.00	Complies
5580 MHz	3.46	11.00	Complies
5700 MHz	5.61	11.00	Complies

Configuration IEEE 802.11n (40MHz) Ant. A

Frequency	Power Density (dBm)	Max. Limit (dBm)	Result
5190 MHz	-4.13	4.00	Complies
5230 MHz	3.97	4.00	Complies
5270 MHz	3.90	11.00	Complies
5310 MHz	-1.67	11.00	Complies
5510 MHz	1.62	11.00	Complies
5550 MHz	1.58	11.00	Complies
5670 MHz	2.83	11.00	Complies

**For Two Chain:
Configuration IEEE 802.11n (20MHz) Ant. A**

Frequency	Power Density (dBm)	Max. Limit (dBm)	Result
5180 MHz	0.45	4.00	Complies
5200 MHz	0.87	4.00	Complies
5240 MHz	0.92	4.00	Complies
5260 MHz	7.37	11.00	Complies
5280 MHz	6.55	11.00	Complies
5320 MHz	6.27	11.00	Complies
5500 MHz	4.48	11.00	Complies
5580 MHz	3.40	11.00	Complies
5700 MHz	6.28	11.00	Complies

Configuration IEEE 802.11n (20MHz) Ant. B

Frequency	Power Density (dBm)	Max. Limit (dBm)	Result
5180 MHz	-0.15	4.00	Complies
5200 MHz	0.73	4.00	Complies
5240 MHz	-0.14	4.00	Complies
5260 MHz	6.00	11.00	Complies
5280 MHz	6.97	11.00	Complies
5320 MHz	6.63	11.00	Complies
5500 MHz	3.27	11.00	Complies
5580 MHz	3.43	11.00	Complies
5700 MHz	5.98	11.00	Complies

Configuration IEEE 802.11n (20MHz) Ant. A+Ant. B

Frequency	Power Density (dBm)	Max. Limit (dBm)	Result
5180 MHz	3.17	4.00	Complies
5200 MHz	3.81	4.00	Complies
5240 MHz	3.43	4.00	Complies
5260 MHz	9.75	11.00	Complies
5280 MHz	9.78	11.00	Complies
5320 MHz	9.46	11.00	Complies
5500 MHz	6.93	11.00	Complies
5580 MHz	6.43	11.00	Complies
5700 MHz	9.14	11.00	Complies

Configuration IEEE 802.11n (40MHz) Ant. A

Frequency	Power Density (dBm)	Max. Limit (dBm)	Result
5190 MHz	-4.90	4.00	Complies
5230 MHz	0.75	4.00	Complies
5270 MHz	5.81	11.00	Complies
5310 MHz	-0.22	11.00	Complies
5510 MHz	-0.16	11.00	Complies
5550 MHz	3.30	11.00	Complies
5670 MHz	4.59	11.00	Complies

Configuration IEEE 802.11n (40MHz) Ant. B

Frequency	Power Density (dBm)	Max. Limit (dBm)	Result
5190 MHz	-7.13	4.00	Complies
5230 MHz	-0.01	4.00	Complies
5270 MHz	5.20	11.00	Complies
5310 MHz	-0.87	11.00	Complies
5510 MHz	-2.76	11.00	Complies
5550 MHz	1.46	11.00	Complies
5670 MHz	3.51	11.00	Complies

Configuration IEEE 802.11n (40MHz) Ant. A+Ant. B

Frequency	Power Density (dBm)	Max. Limit (dBm)	Result
5190 MHz	-2.86	4.00	Complies
5230 MHz	3.40	4.00	Complies
5270 MHz	8.53	11.00	Complies
5310 MHz	2.48	11.00	Complies
5510 MHz	1.74	11.00	Complies
5550 MHz	5.49	11.00	Complies
5670 MHz	7.09	11.00	Complies

For Single Chain:
Power Density Plot on Configuration IEEE 802.11a Ant. A / 5180 MHz

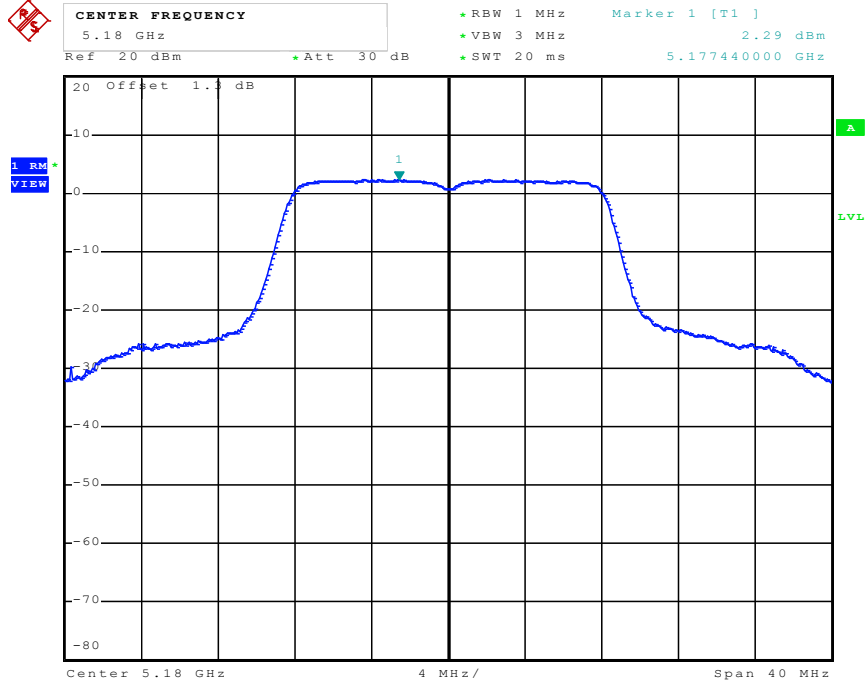

Date: 23.MAY.2011 11:19:02

Power Density Plot on Configuration IEEE 802.11a Ant. A / 5200 MHz

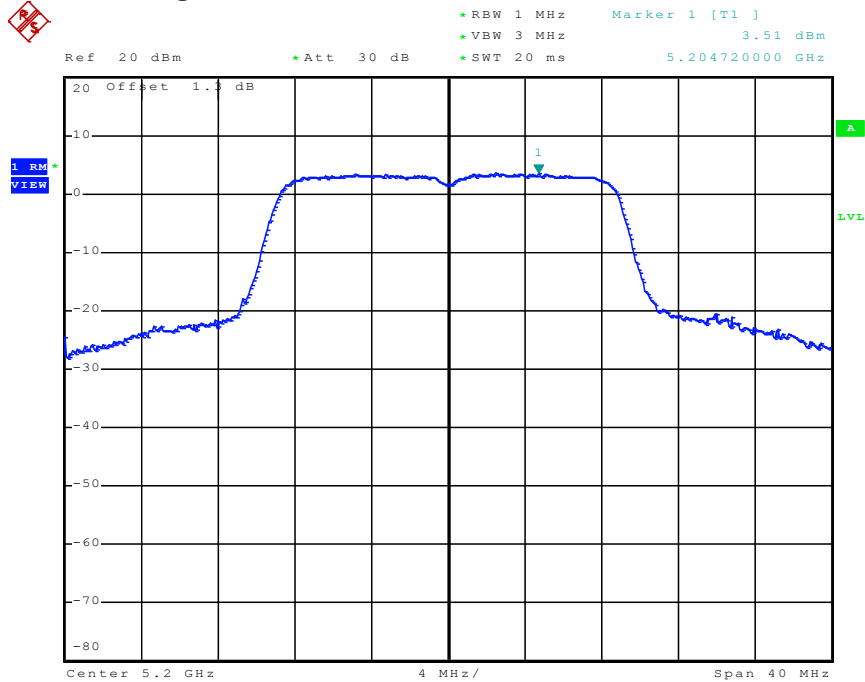

Date: 3.MAY.2011 10:29:56

Power Density Plot on Configuration IEEE 802.11a Ant. A / 5240 MHz

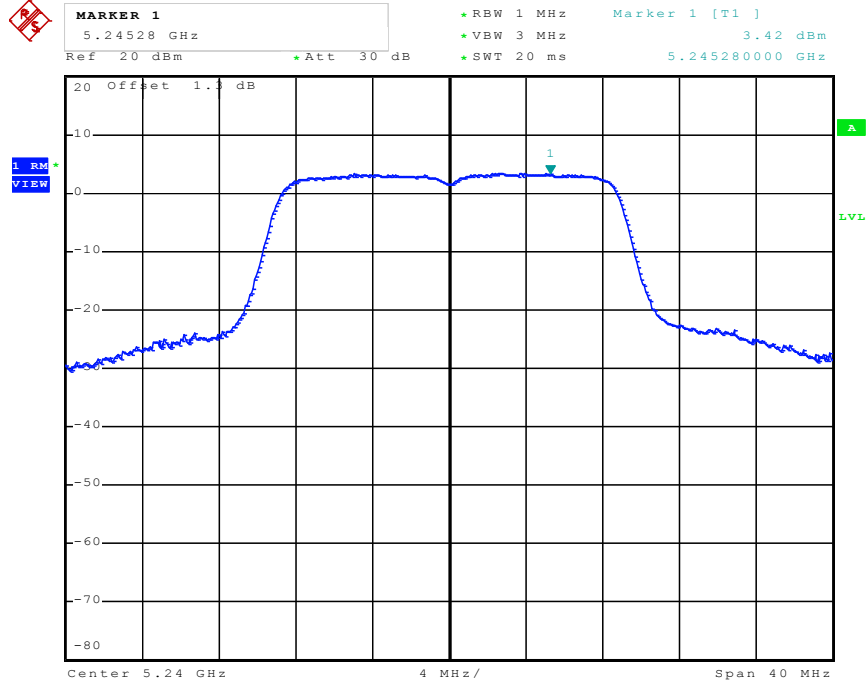

Date: 3.MAY.2011 10:32:55

Power Density Plot on Configuration IEEE 802.11a Ant. A / 5260 MHz

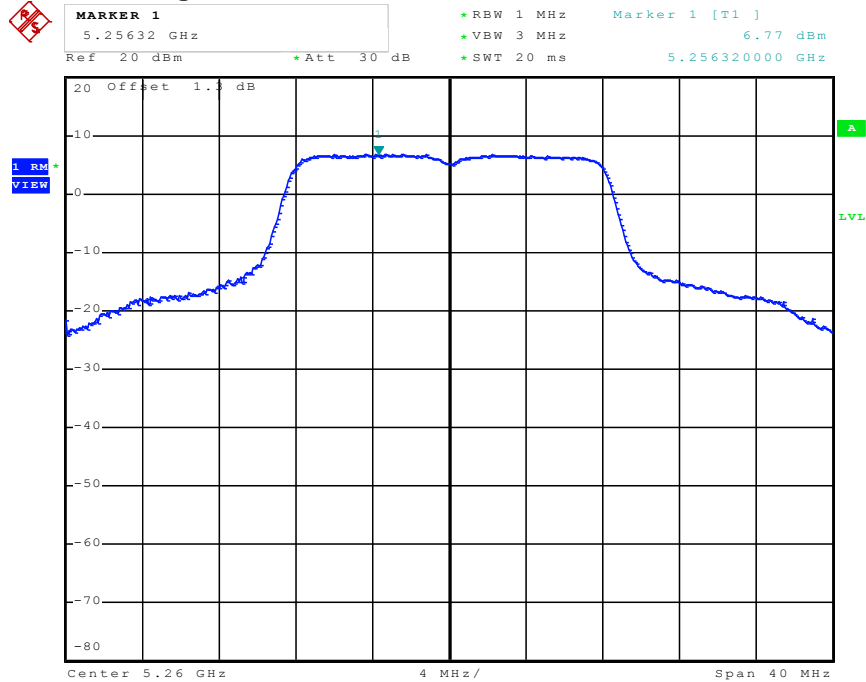

Date: 3.MAY.2011 12:00:50

Power Density Plot on Configuration IEEE 802.11a Ant. A / 5280 MHz

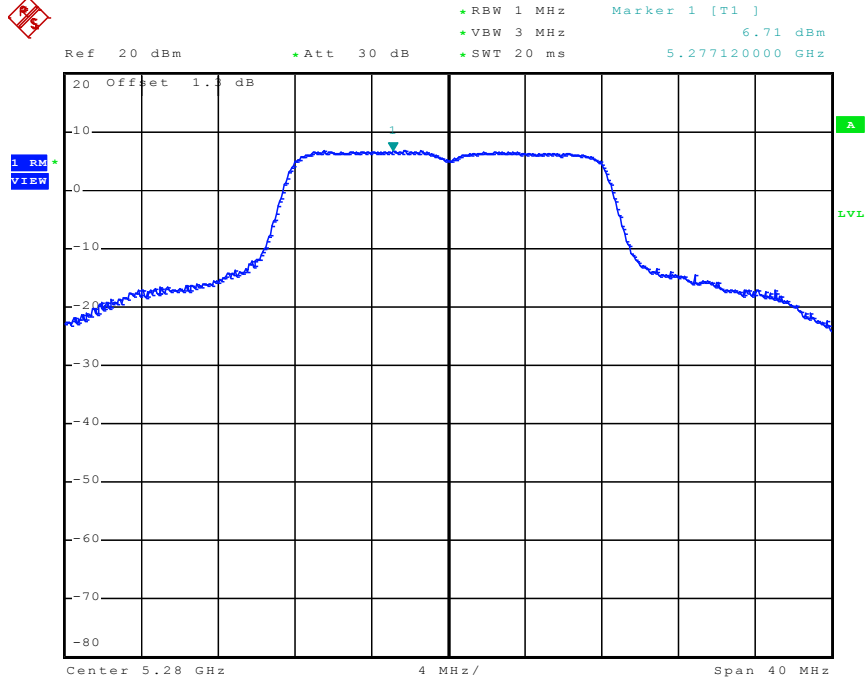

Date: 3.MAY.2011 12:06:22

Power Density Plot on Configuration IEEE 802.11a Ant. A / 5320 MHz

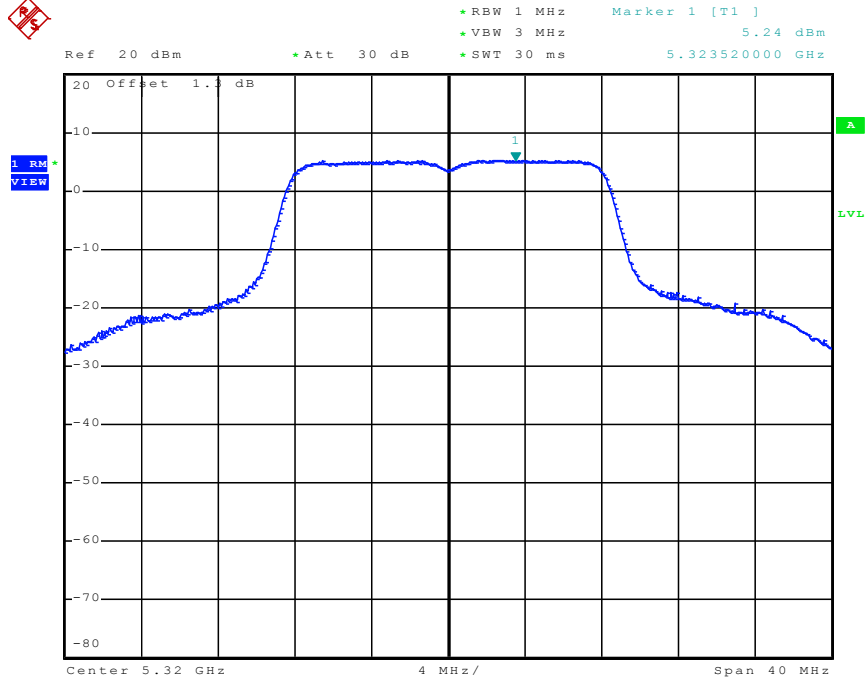

Date: 23.MAY.2011 11:34:54

Power Density Plot on Configuration IEEE 802.11a Ant. A / 5500 MHz

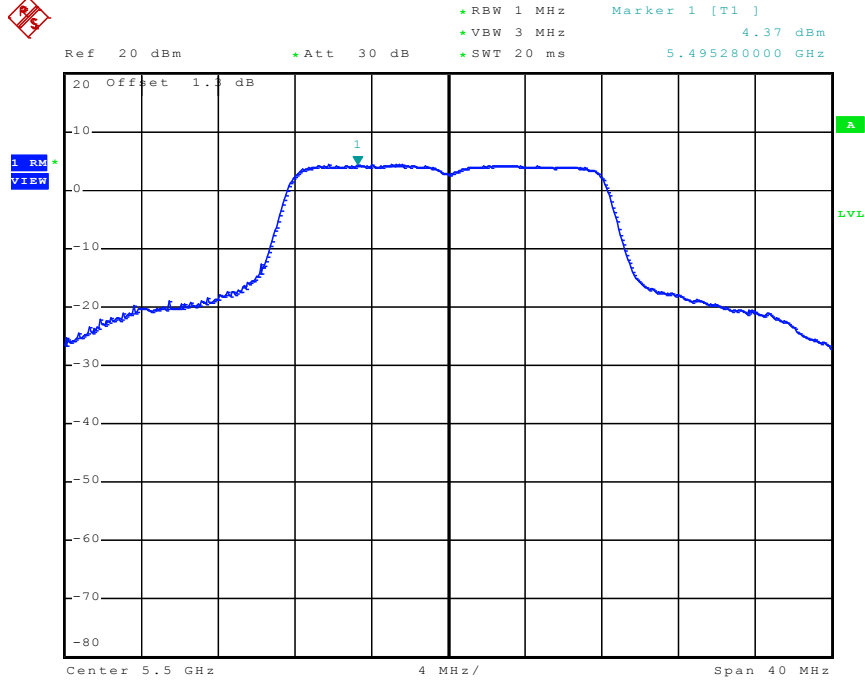

Date: 3.MAY.2011 12:11:58

Power Density Plot on Configuration IEEE 802.11a Ant. A / 5580 MHz

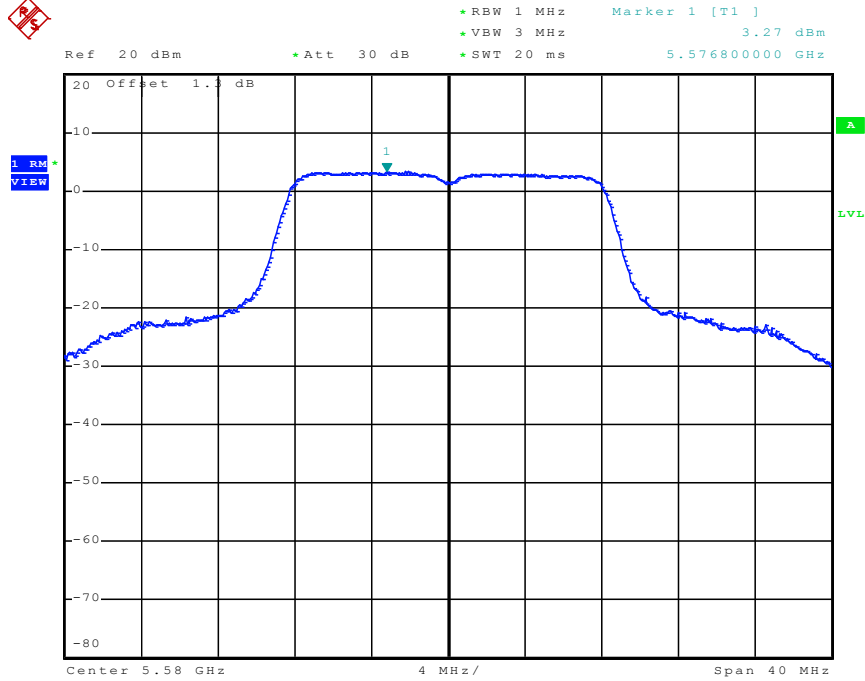

Date: 3.MAY.2011 12:14:52

Power Density Plot on Configuration IEEE 802.11a Ant. A / 5700 MHz

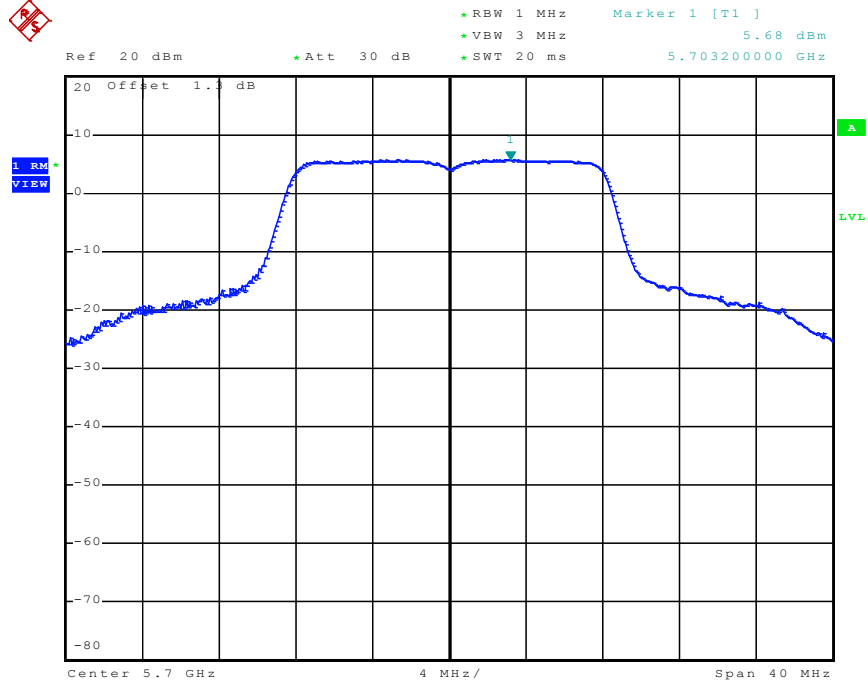

Date: 3.MAY.2011 12:17:57

Power Density Plot on Configuration IEEE 802.11n Ant. A (20MHz) / 5180 MHz

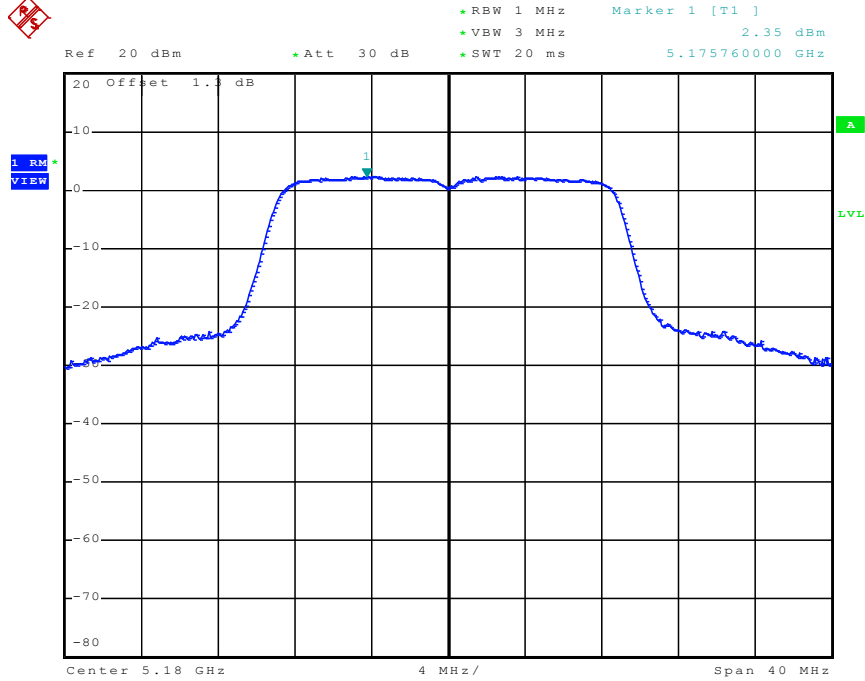

Date: 23.MAY.2011 11:48:43

Power Density Plot on Configuration IEEE 802.11n Ant. A (20MHz) / 5200 MHz

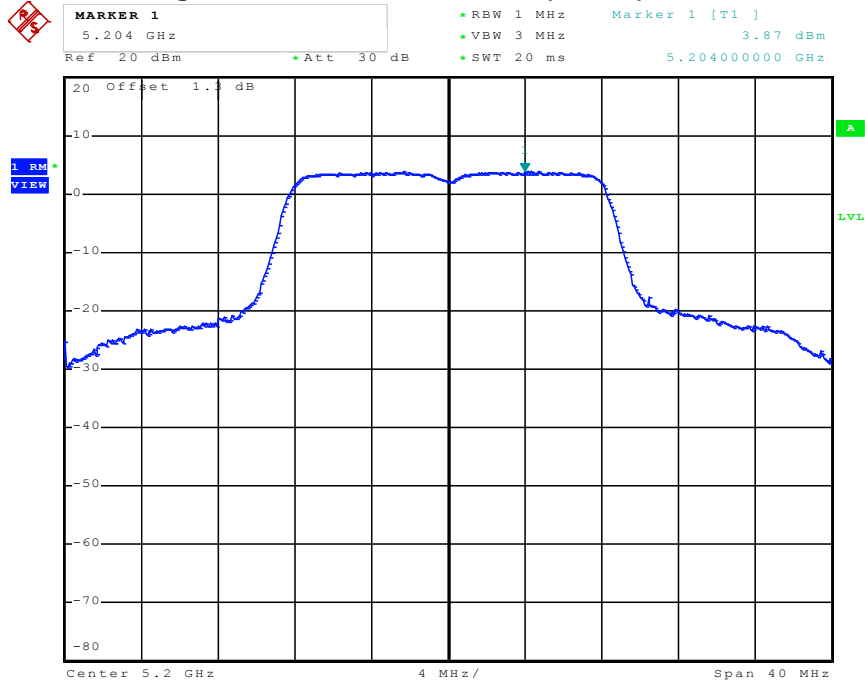

Date: 3.MAY.2011 11:10:15

Power Density Plot on Configuration IEEE 802.11n Ant. A (20MHz) / 5240 MHz

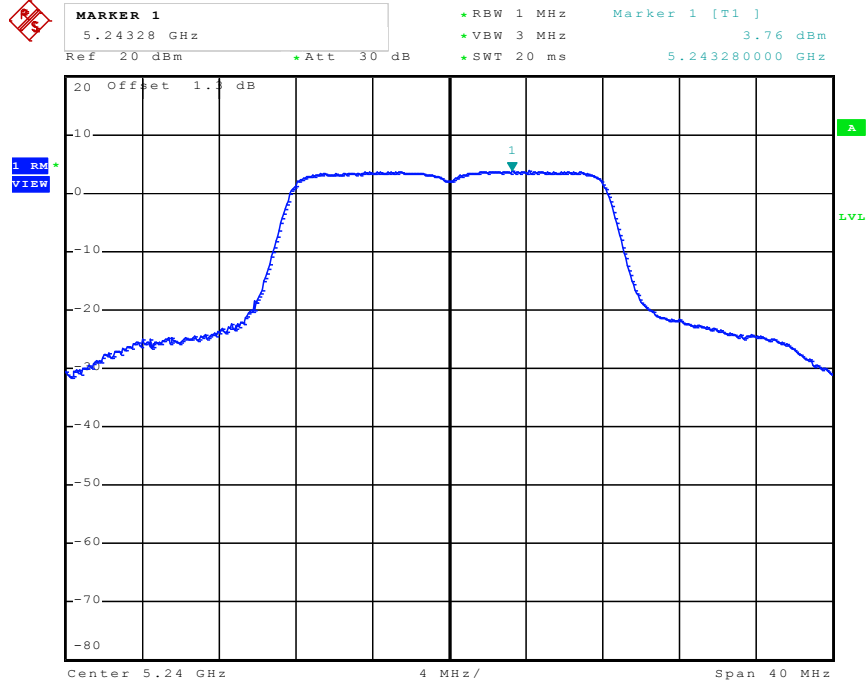

Date: 3.MAY.2011 11:11:53

Power Density Plot on Configuration IEEE 802.11n Ant. A (20MHz) / 5260 MHz

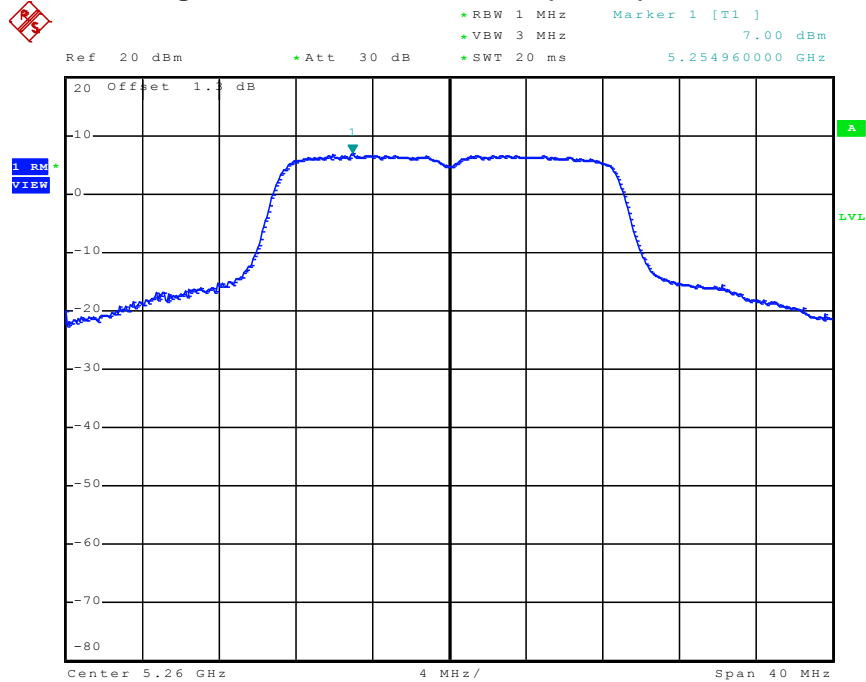

Date: 3.MAY.2011 14:47:12

Power Density Plot on Configuration IEEE 802.11n Ant. A (20MHz) / 5280 MHz

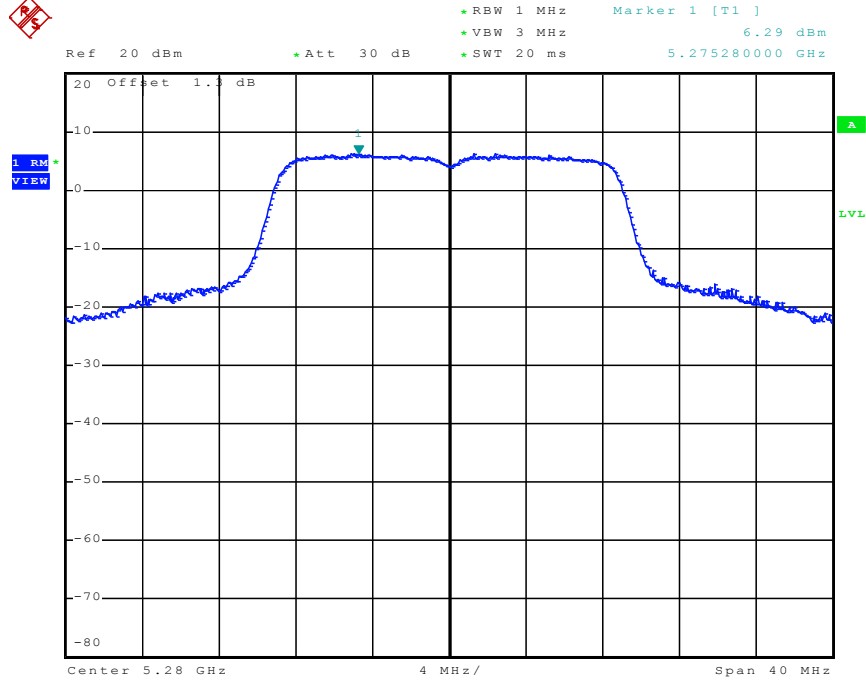

Date: 3.MAY.2011 14:50:12

Power Density Plot on Configuration IEEE 802.11n Ant. A (20MHz) / 5320 MHz

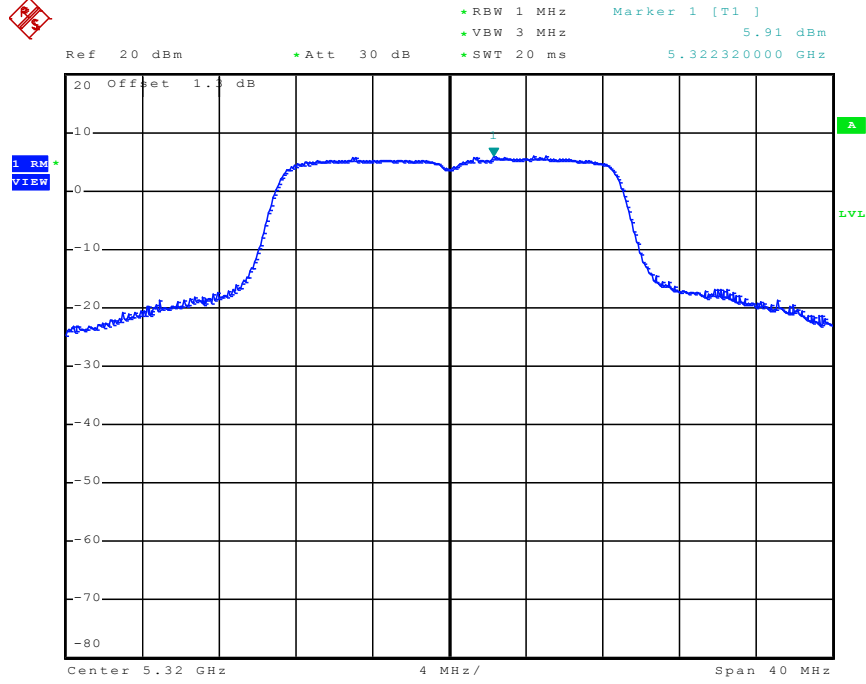

Date: 23.MAY.2011 11:54:35

Power Density Plot on Configuration IEEE 802.11n Ant. A (20MHz) / 5500 MHz

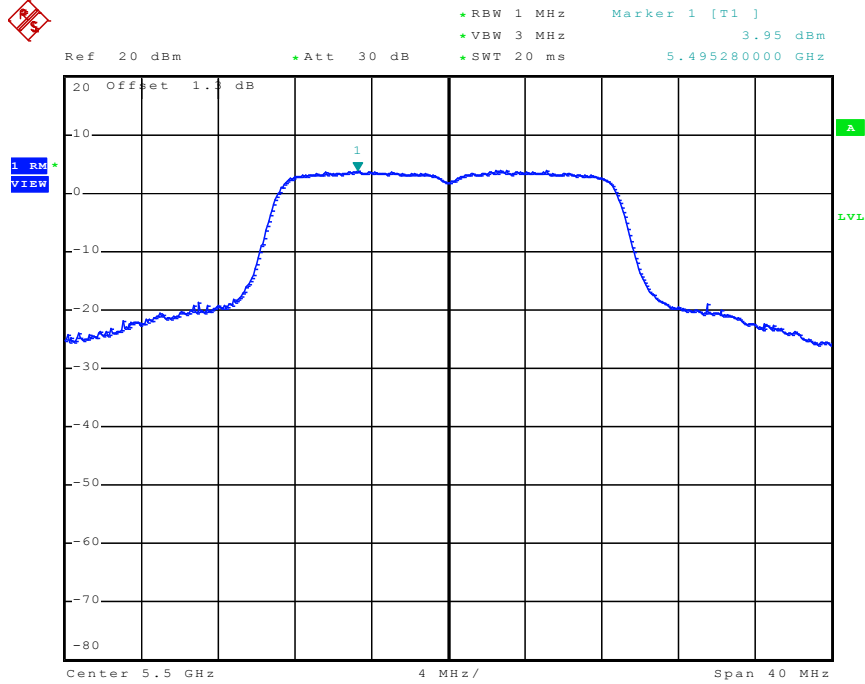

Date: 3.MAY.2011 14:56:25

Power Density Plot on Configuration IEEE 802.11n Ant. A (20MHz) / 5580 MHz

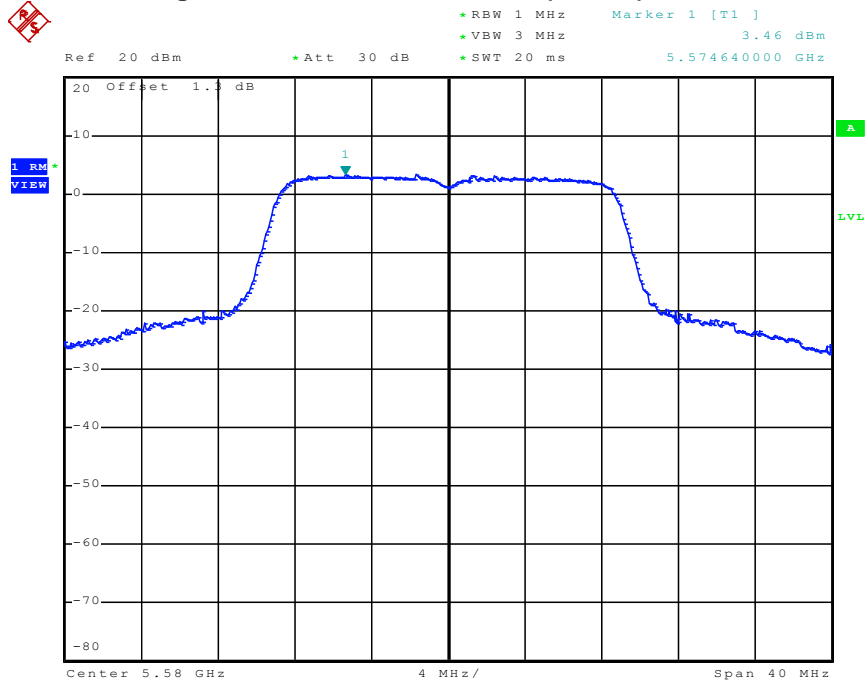

Date: 3.MAY.2011 15:00:33

Power Density Plot on Configuration IEEE 802.11n Ant. A (20MHz) / 5700 MHz

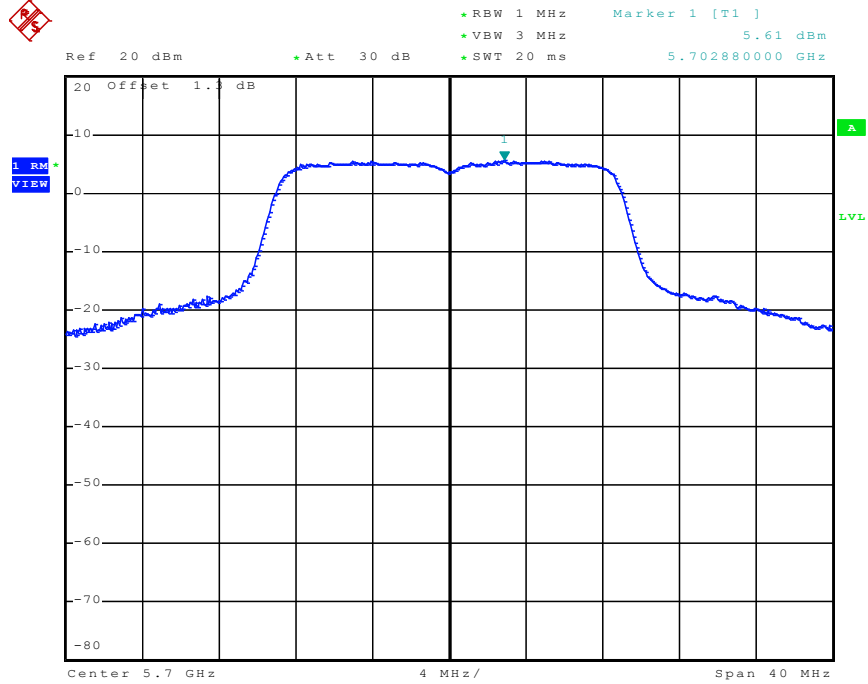

Date: 3.MAY.2011 15:04:29

Power Density Plot on Configuration IEEE 802.11n Ant. A (40MHz) / 5190 MHz

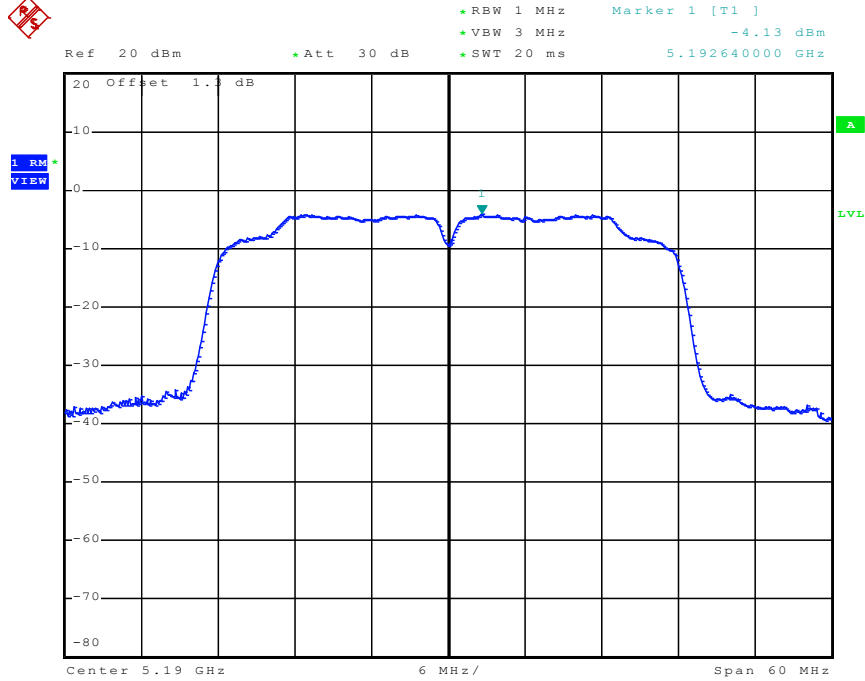

Date: 23.MAY.2011 12:08:31

Power Density Plot on Configuration IEEE 802.11n Ant. A (40MHz) / 5230 MHz

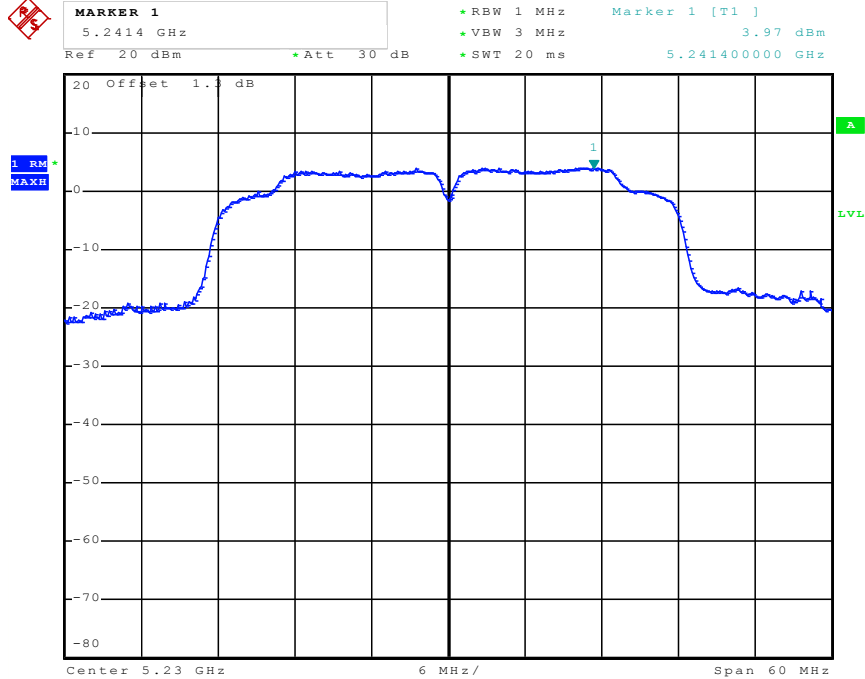

Date: 3.MAY.2011 11:37:43

Power Density Plot on Configuration IEEE 802.11n Ant. A (40MHz) / 5270 MHz

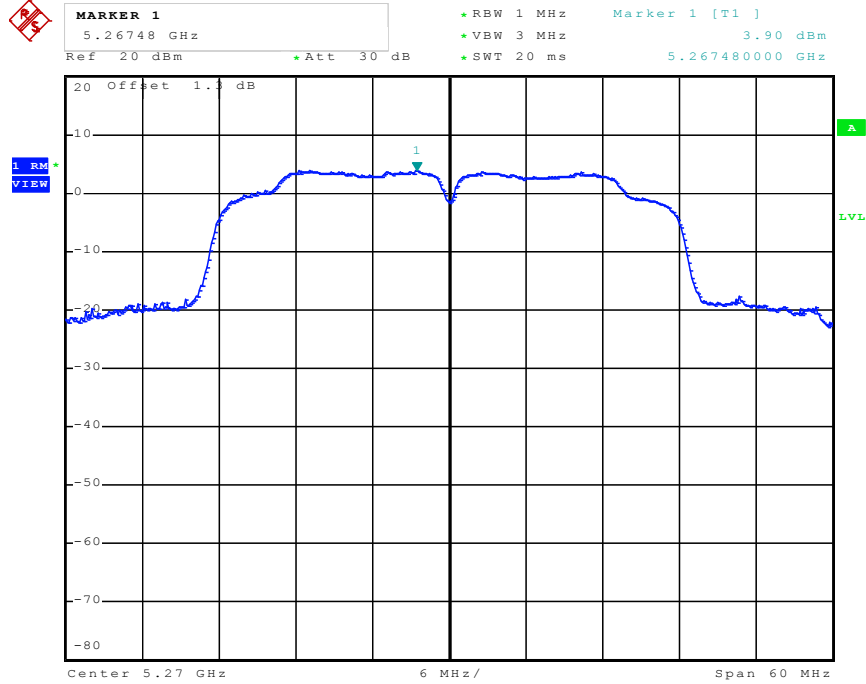

Date: 3.MAY.2011 16:12:11

Power Density Plot on Configuration IEEE 802.11n Ant. A (40MHz) / 5310 MHz

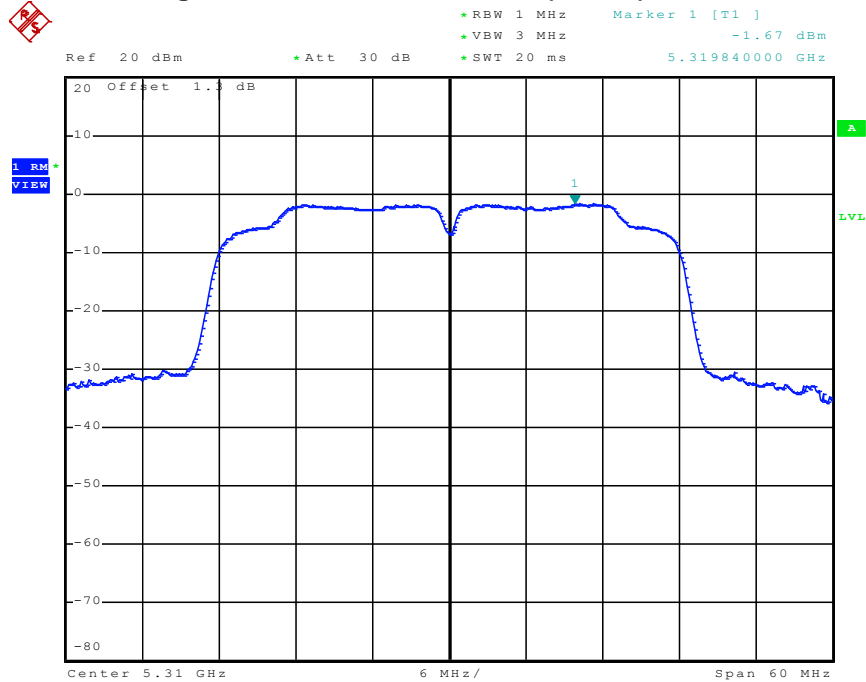

Date: 23.MAY.2011 12:12:24

Power Density Plot on Configuration IEEE 802.11n Ant. A (40MHz) / 5510 MHz

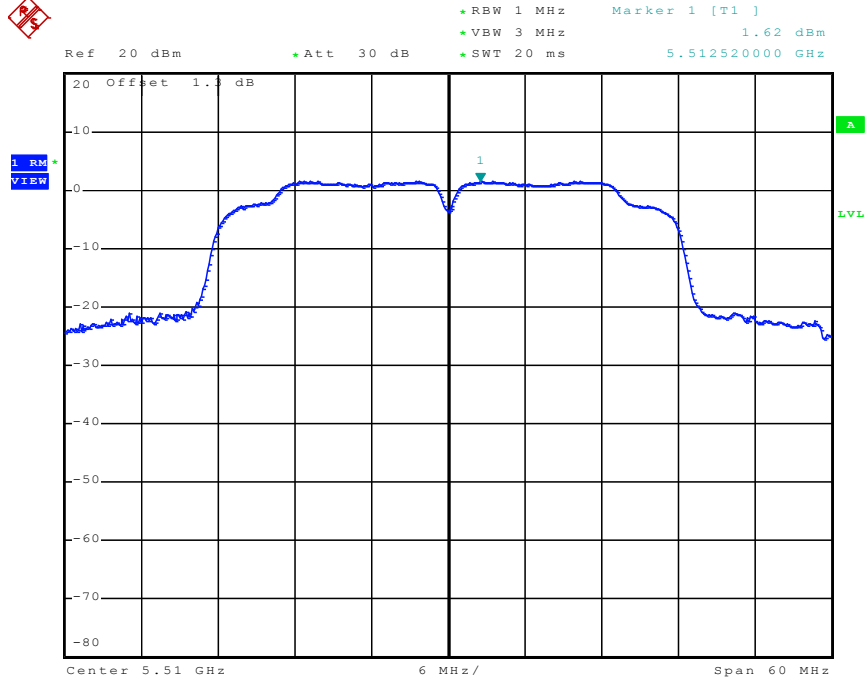

Date: 3.MAY.2011 16:17:35

Power Density Plot on Configuration IEEE 802.11n Ant. A (40MHz) / 5550 MHz

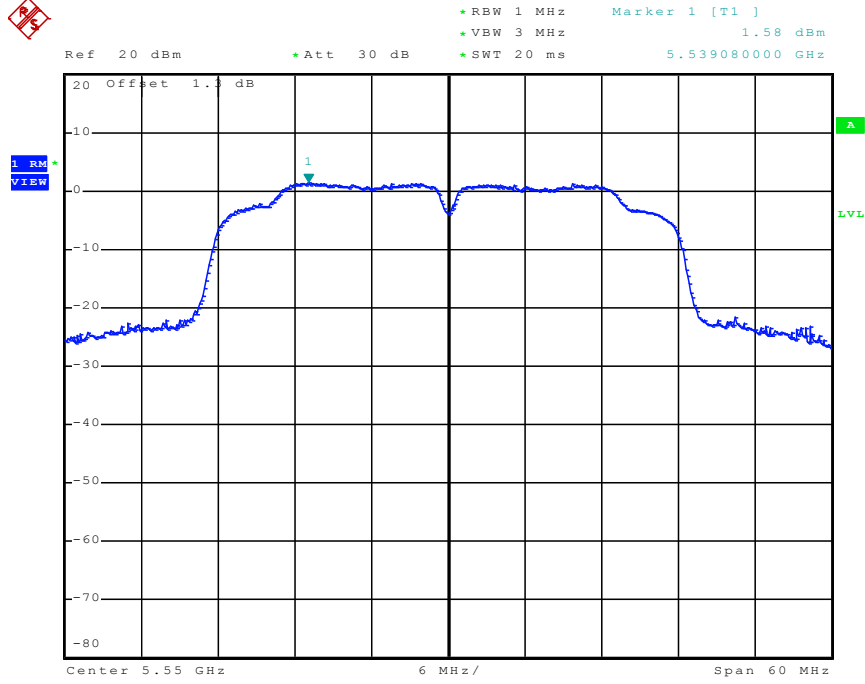

Date: 3.MAY.2011 16:20:30

Power Density Plot on Configuration IEEE 802.11n Ant. A (40MHz) / 5670 MHz

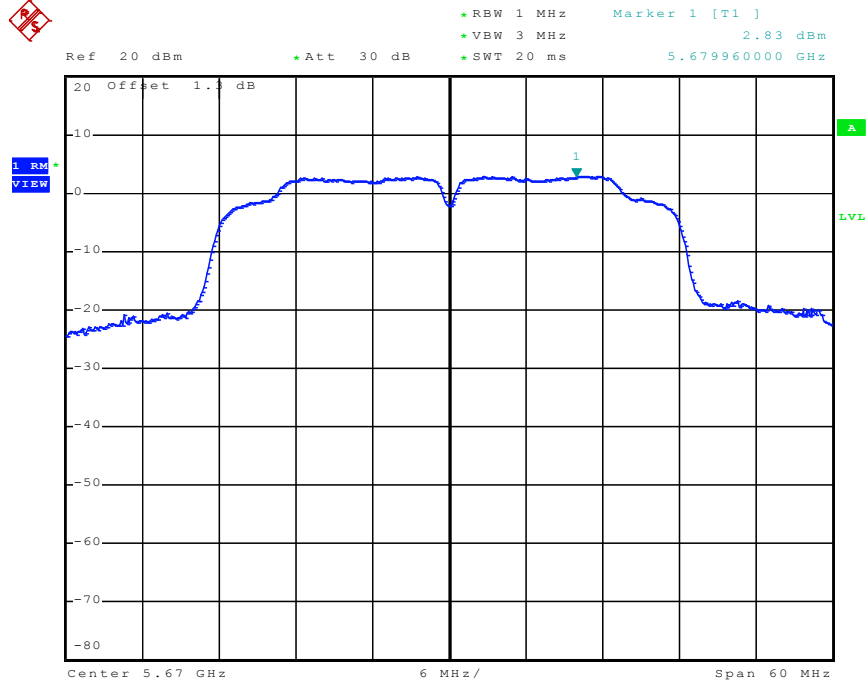

Date: 3.MAY.2011 16:23:20

For Two Chain:
Power Density Plot on Configuration IEEE 802.11n Ant. A (20MHz) / 5180 MHz

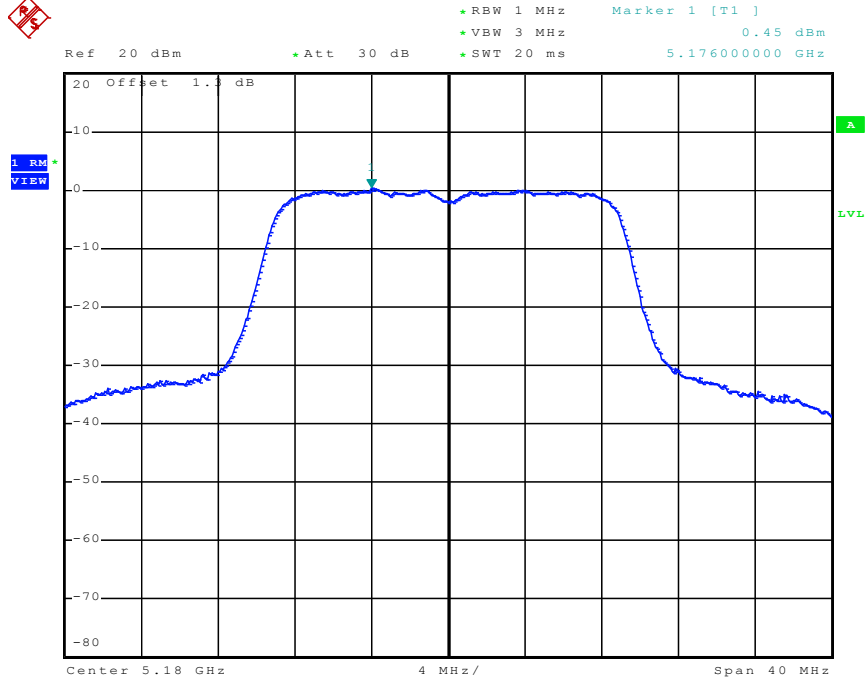

Date: 3.MAY.2011 17:04:52

Power Density Plot on Configuration IEEE 802.11n Ant. A (20MHz) / 5200 MHz

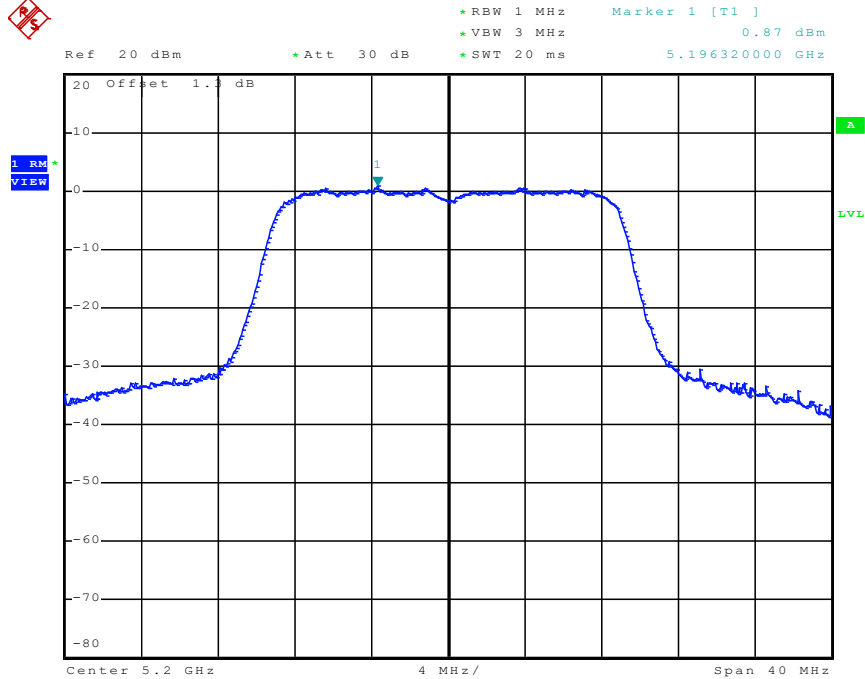

Date: 3.MAY.2011 17:08:23

Power Density Plot on Configuration IEEE 802.11n Ant. A (20MHz) / 5240 MHz

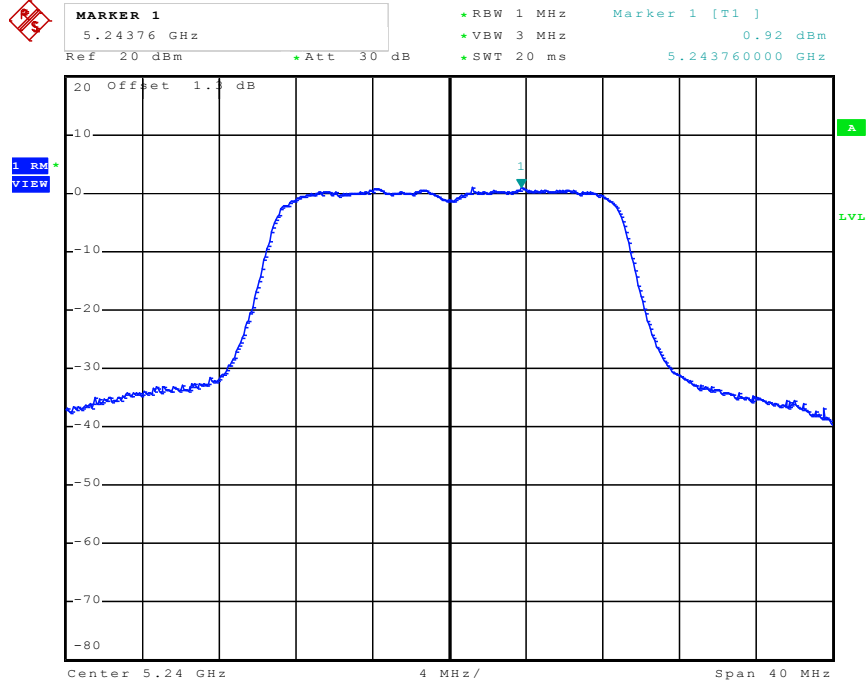

Date: 3.MAY.2011 17:11:42

Power Density Plot on Configuration IEEE 802.11n Ant. A (20MHz) / 5260 MHz

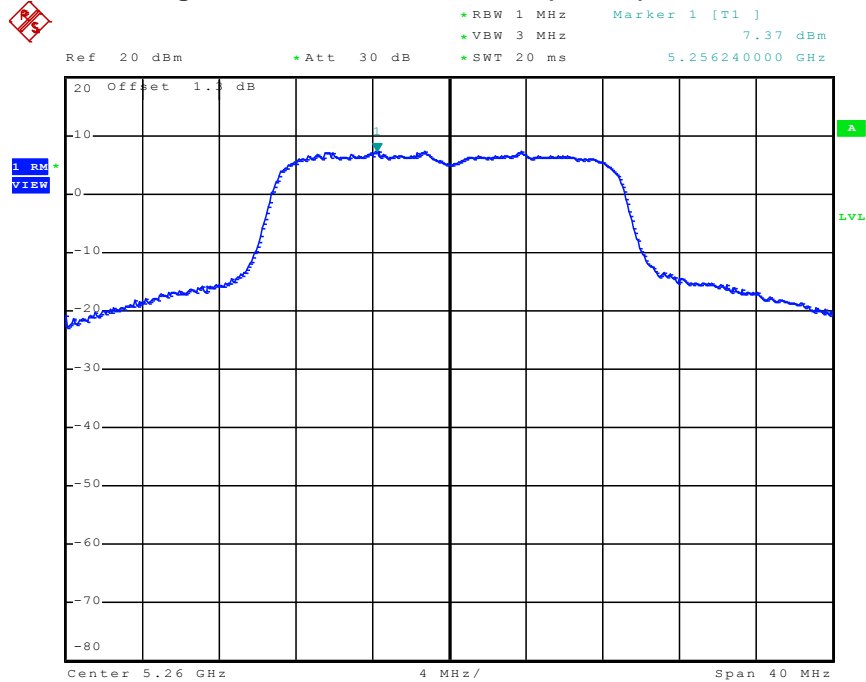

Date: 3.MAY.2011 20:37:29

Power Density Plot on Configuration IEEE 802.11n Ant. A (20MHz) / 5280 MHz

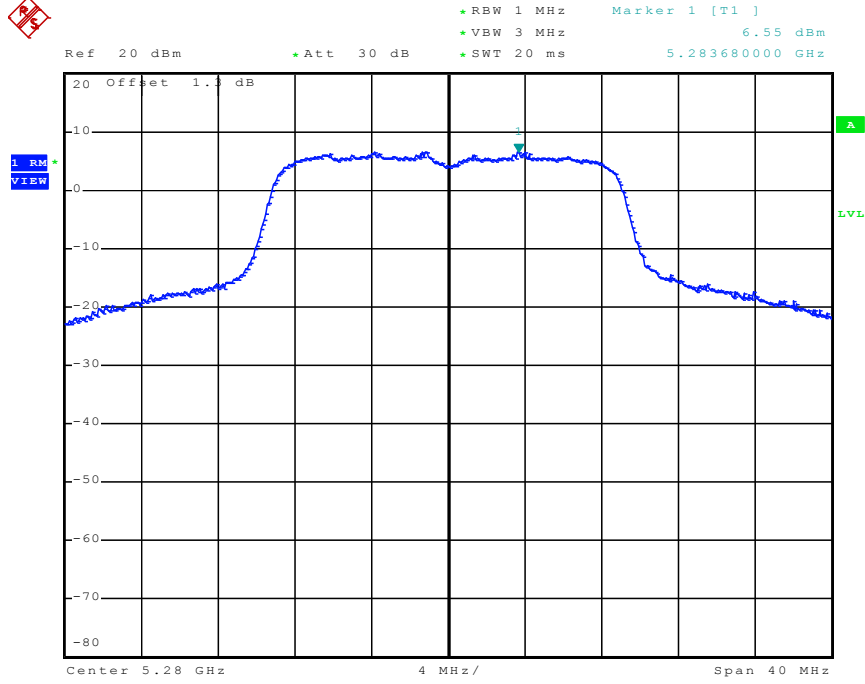

Date: 3.MAY.2011 20:40:09

Power Density Plot on Configuration IEEE 802.11n Ant. A (20MHz) / 5320 MHz

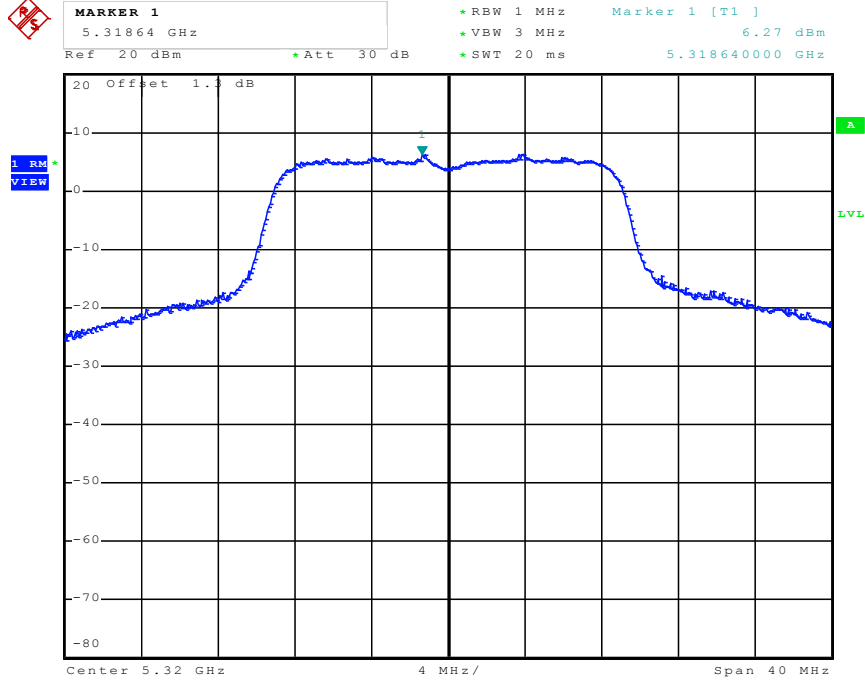

Date: 23.MAY.2011 14:35:21

Power Density Plot on Configuration IEEE 802.11n Ant. A (20MHz) / 5500 MHz

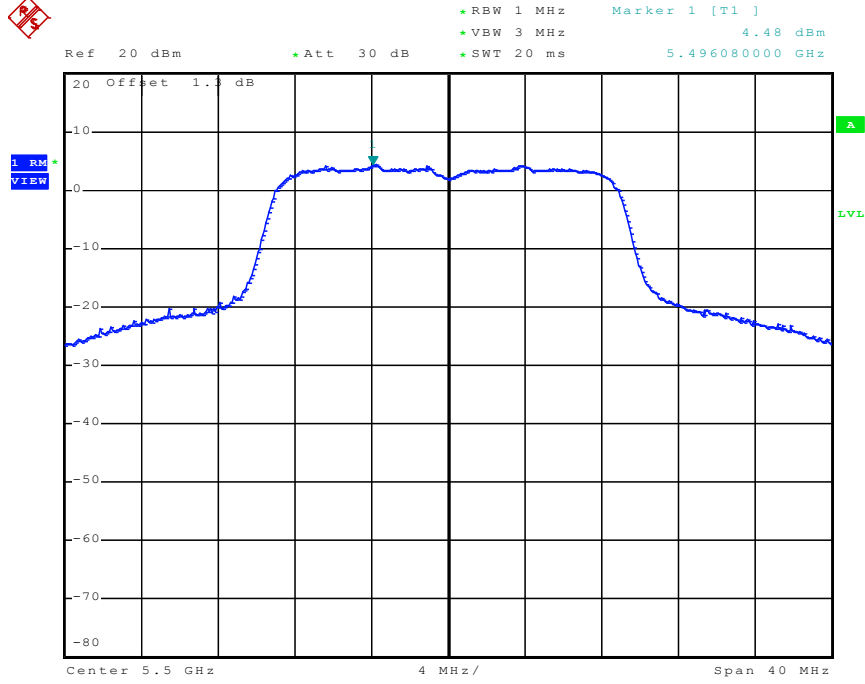

Date: 3.MAY.2011 20:45:23

Power Density Plot on Configuration IEEE 802.11n Ant. A (20MHz) / 5580 MHz

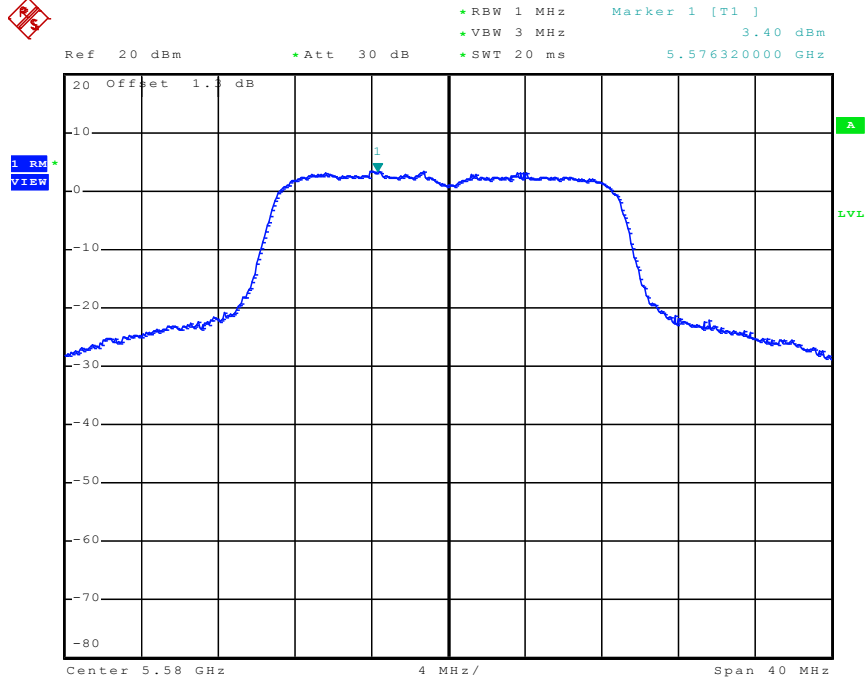

Date: 3.MAY.2011 20:48:20

Power Density Plot on Configuration IEEE 802.11n Ant. A (20MHz) / 5700 MHz

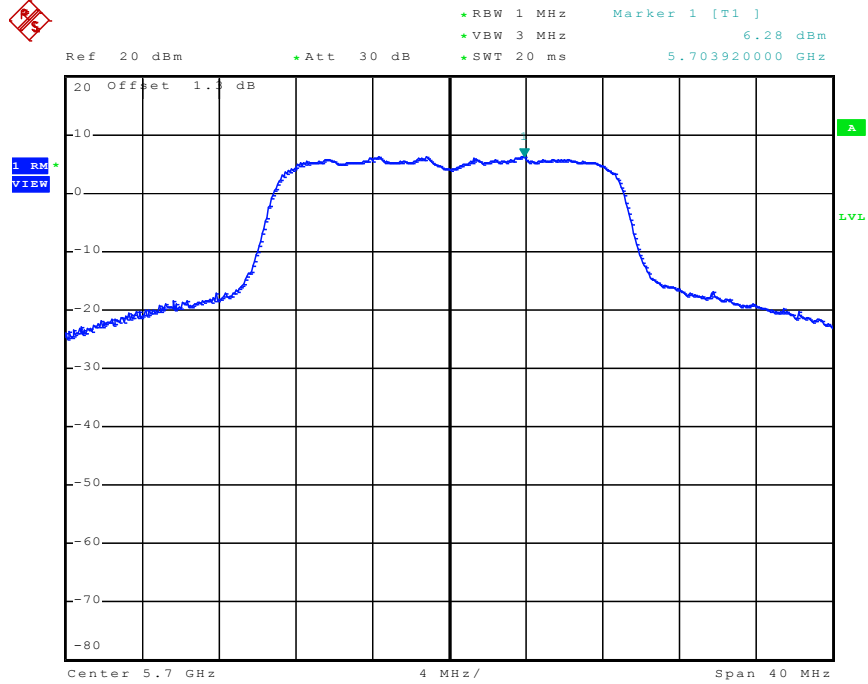

Date: 3.MAY.2011 20:51:18

Power Density Plot on Configuration IEEE 802.11n Ant. B (20MHz) / 5180 MHz

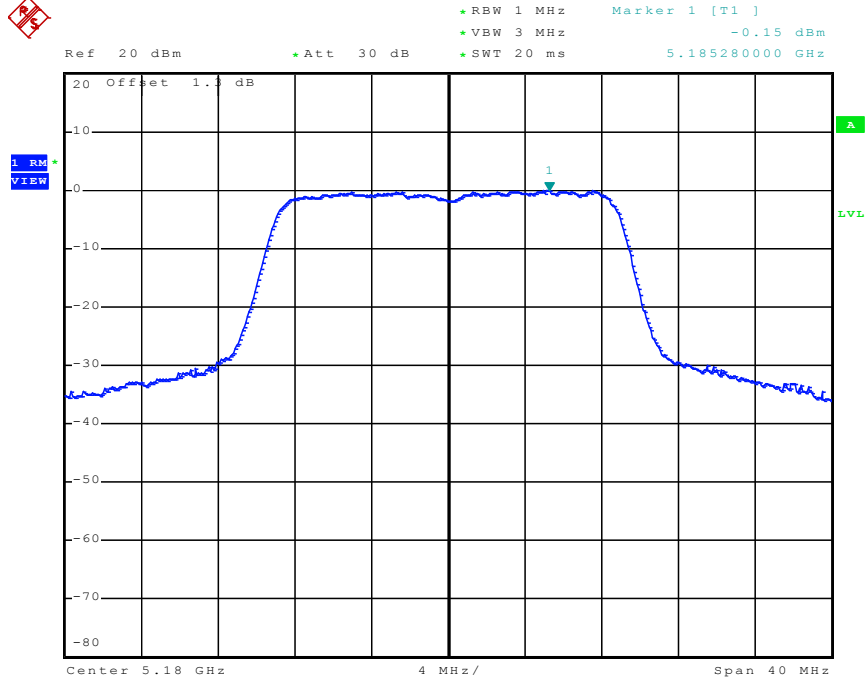

Date: 3.MAY.2011 17:05:47

Power Density Plot on Configuration IEEE 802.11n Ant. B (20MHz) / 5200 MHz

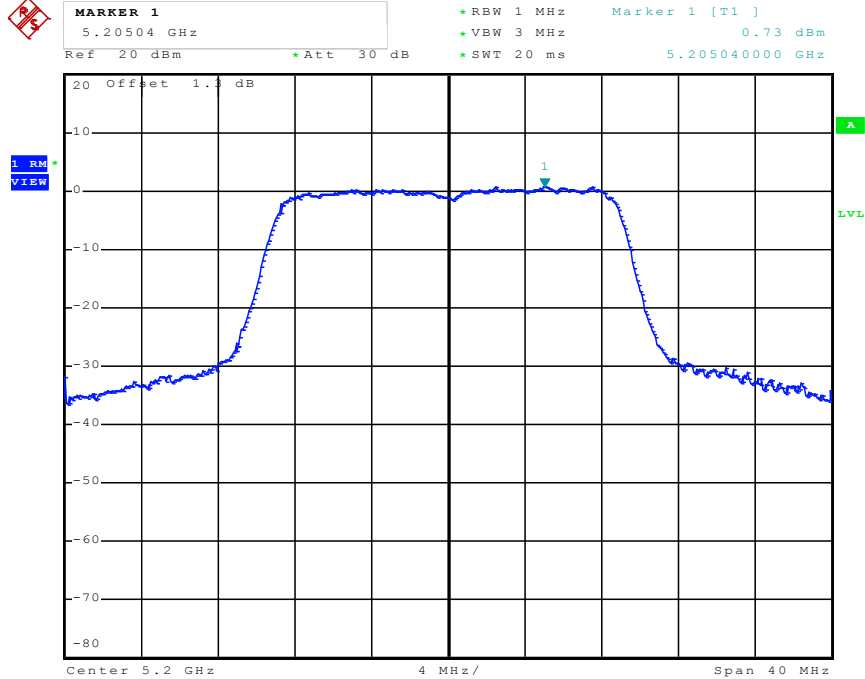

Date: 3.MAY.2011 17:10:13

Power Density Plot on Configuration IEEE 802.11n Ant. B (20MHz) / 5240 MHz

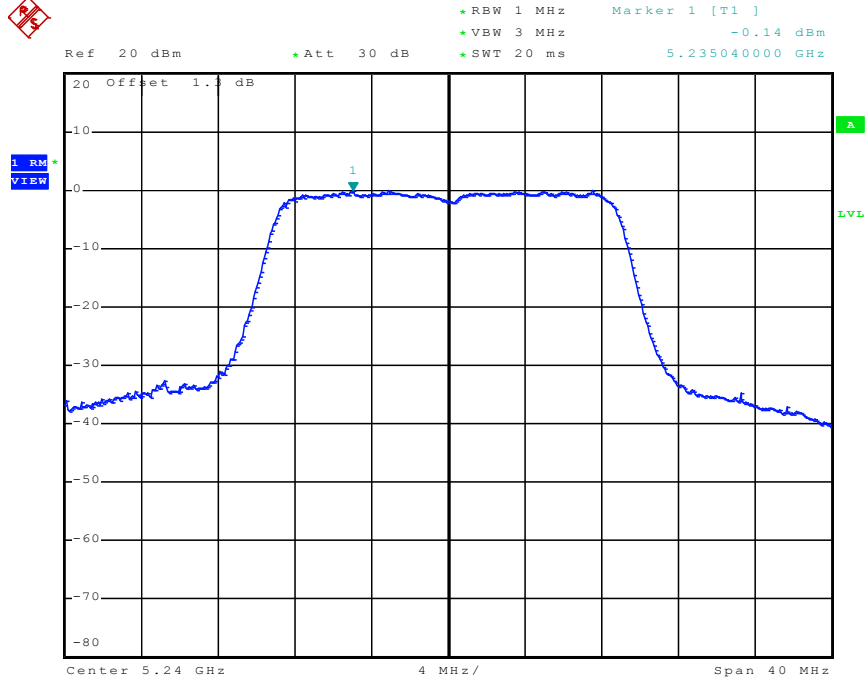

Date: 3.MAY.2011 17:21:13

Power Density Plot on Configuration IEEE 802.11n Ant. B (20MHz) / 5260 MHz

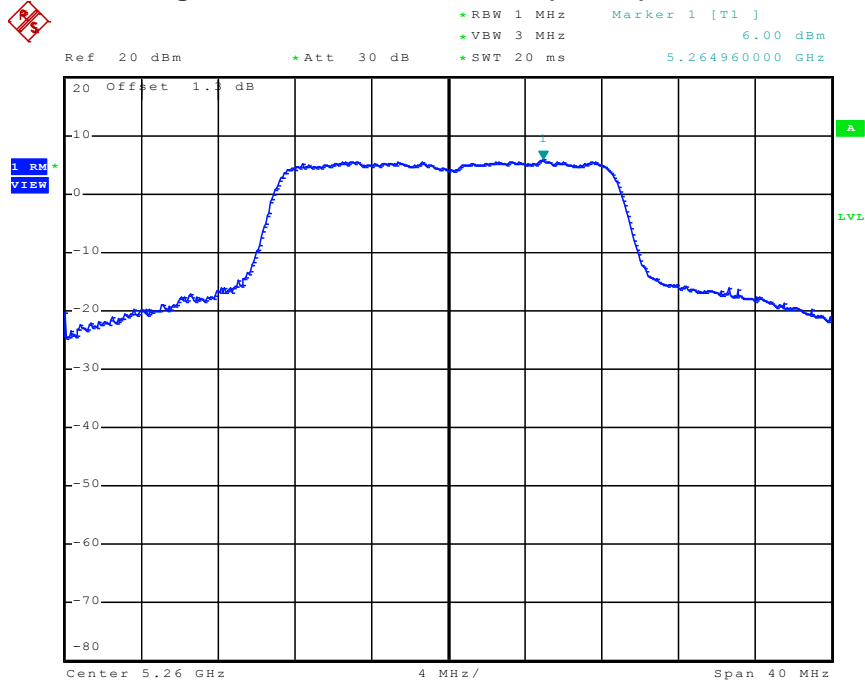

Date: 3.MAY.2011 22:20:29

Power Density Plot on Configuration IEEE 802.11n Ant. B (20MHz) / 5280 MHz

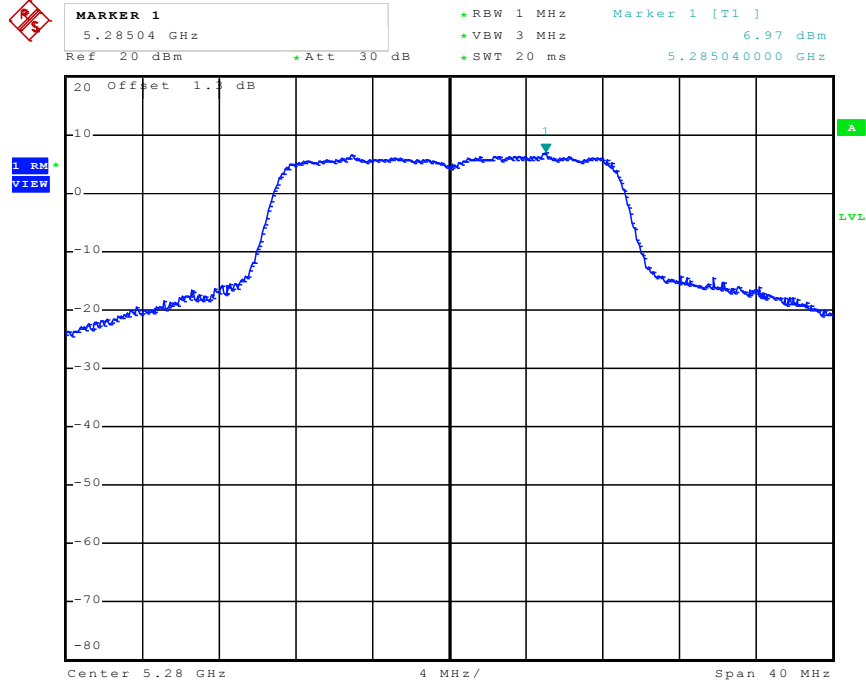

Date: 3.MAY.2011 22:25:10

Power Density Plot on Configuration IEEE 802.11n Ant. B (20MHz) / 5320 MHz

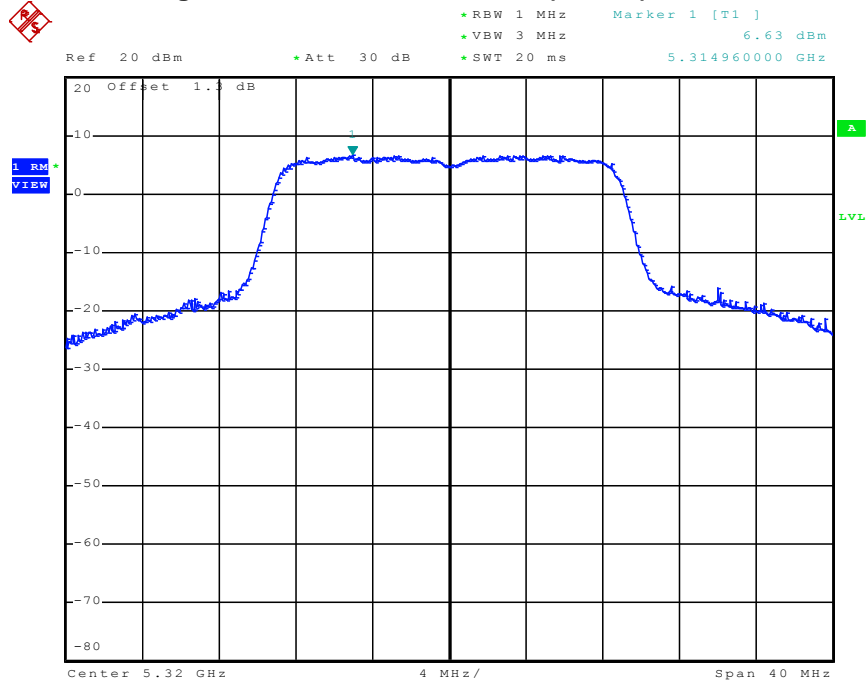

Date: 23.MAY.2011 14:44:59

Power Density Plot on Configuration IEEE 802.11n Ant. B (20MHz) / 5500 MHz

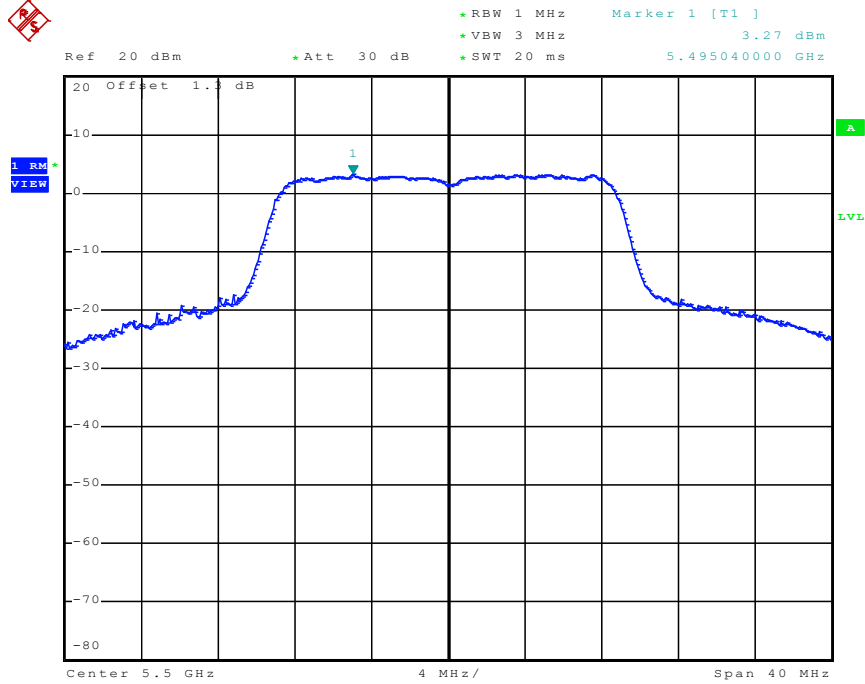

Date: 3.MAY.2011 21:44:45

Power Density Plot on Configuration IEEE 802.11n Ant. B (20MHz) / 5580 MHz

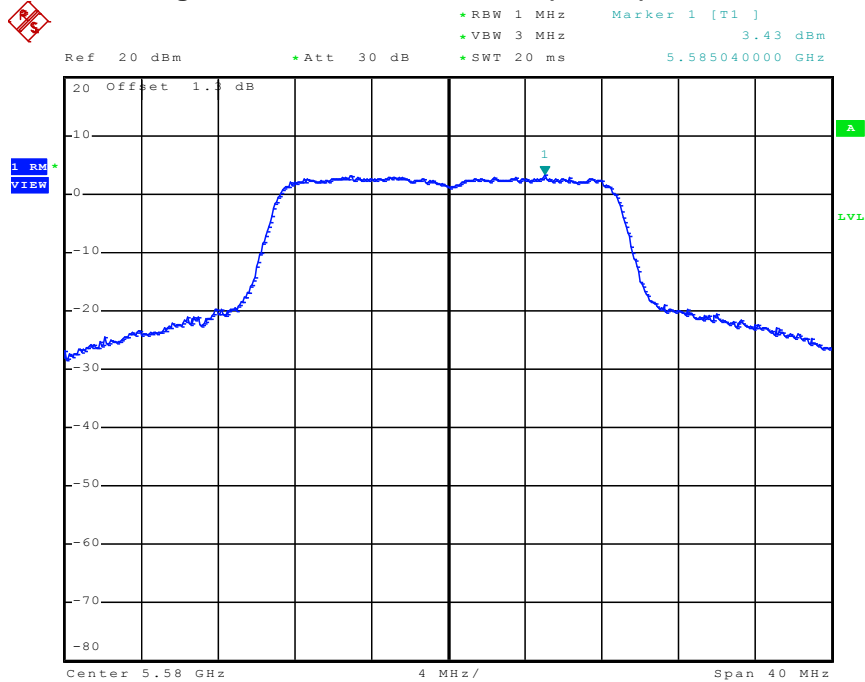

Date: 3.MAY.2011 21:47:03

Power Density Plot on Configuration IEEE 802.11n Ant. B (20MHz) / 5700 MHz

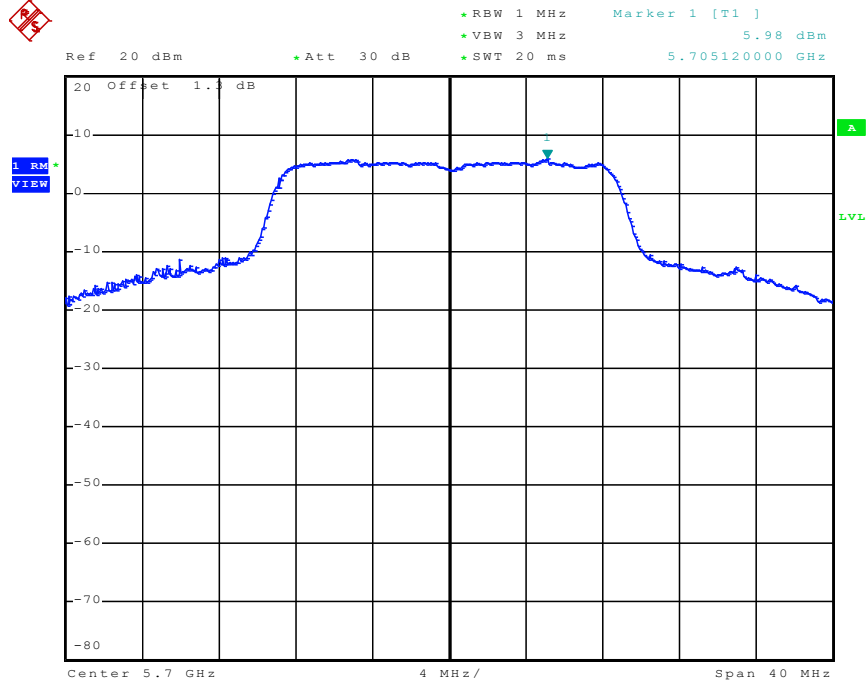

Date: 3.MAY.2011 21:49:58

Power Density Plot on Configuration IEEE 802.11n Ant. A (40MHz) / 5190 MHz

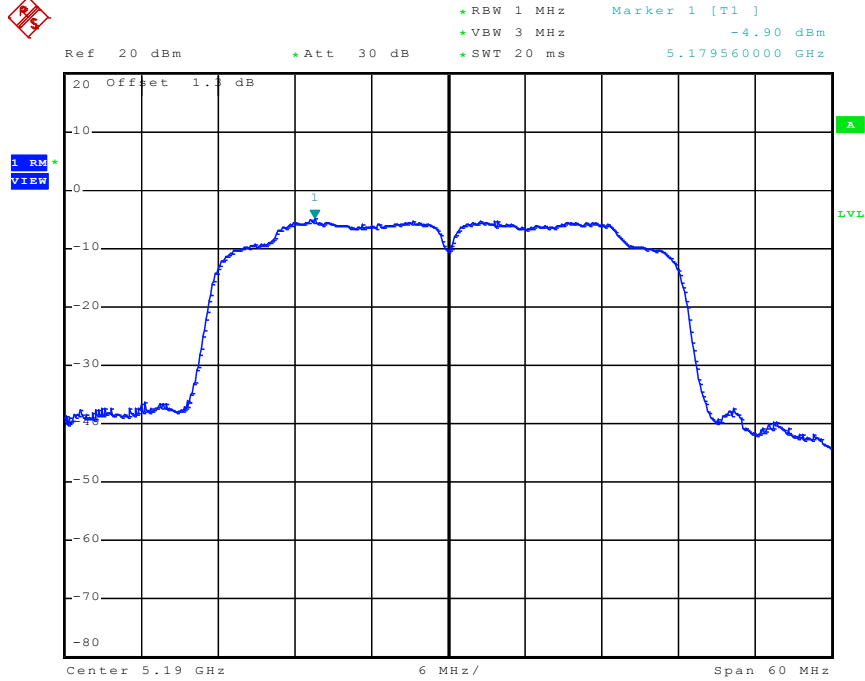

Date: 23.MAY.2011 14:50:48

Power Density Plot on Configuration IEEE 802.11n Ant. A (40MHz) / 5230 MHz

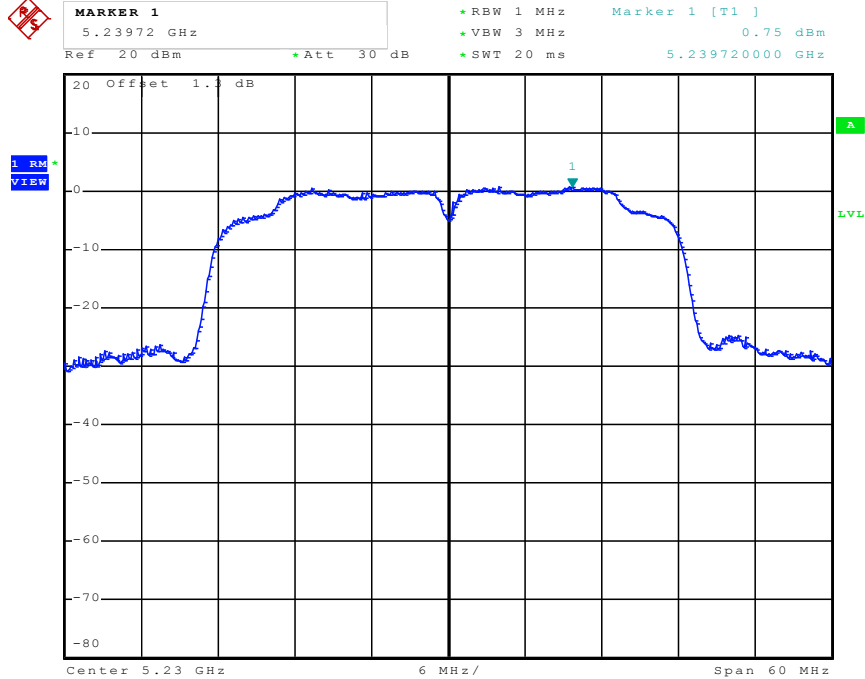

Date: 3.MAY.2011 20:10:43

Power Density Plot on Configuration IEEE 802.11n Ant. A (40MHz) / 5270 MHz

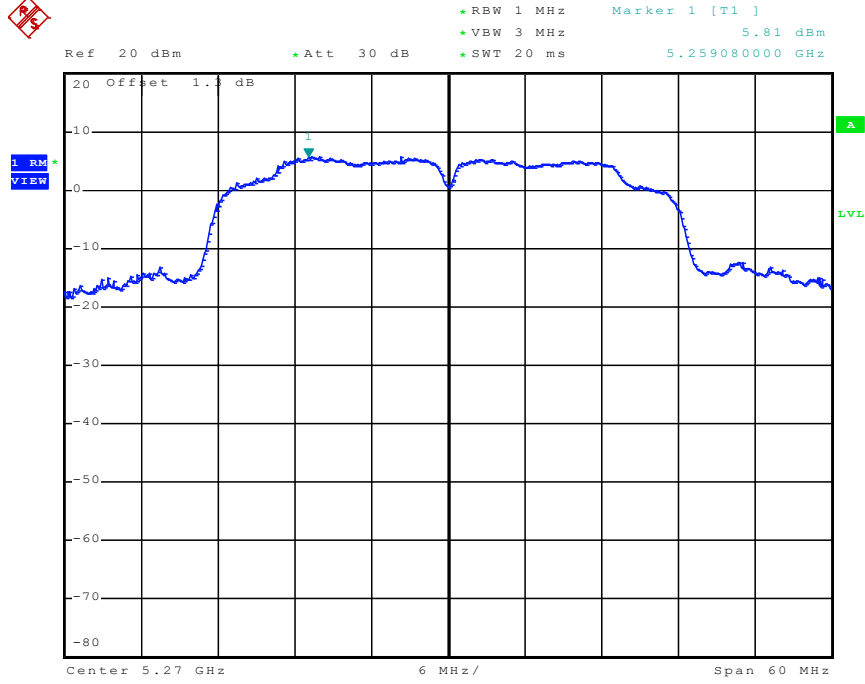

Date: 4.MAY.2011 09:03:51

Power Density Plot on Configuration IEEE 802.11n Ant. A (40MHz) / 5310 MHz

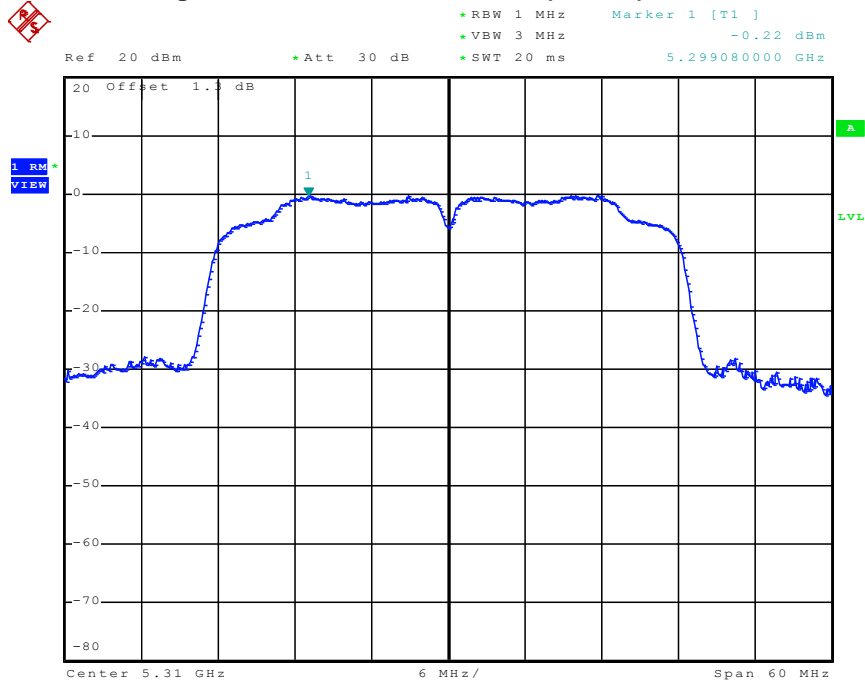

Date: 23.MAY.2011 15:17:37

Power Density Plot on Configuration IEEE 802.11n Ant. A (40MHz) / 5510 MHz

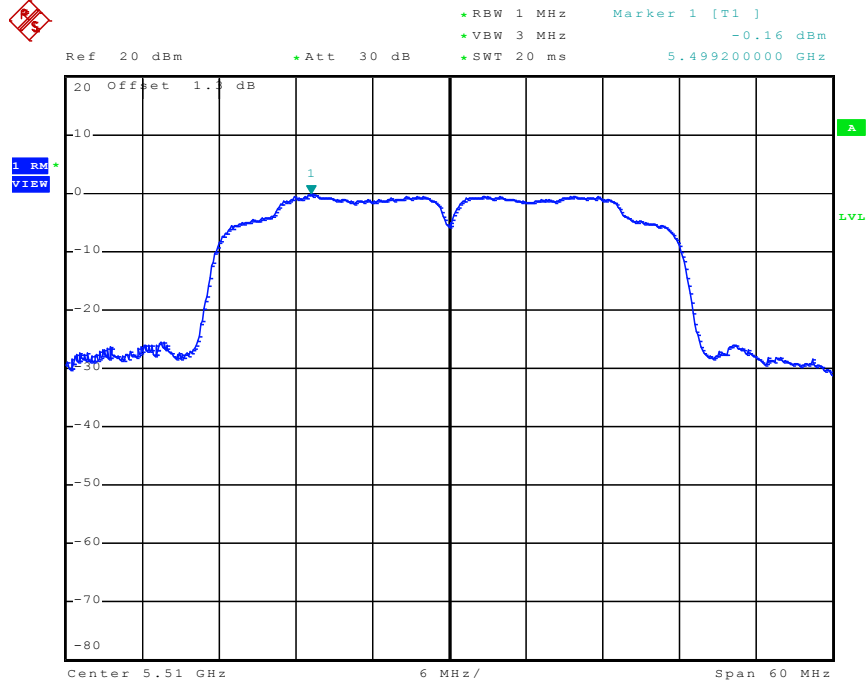

Date: 23.MAY.2011 15:23:45

Power Density Plot on Configuration IEEE 802.11n Ant. A (40MHz) / 5550 MHz

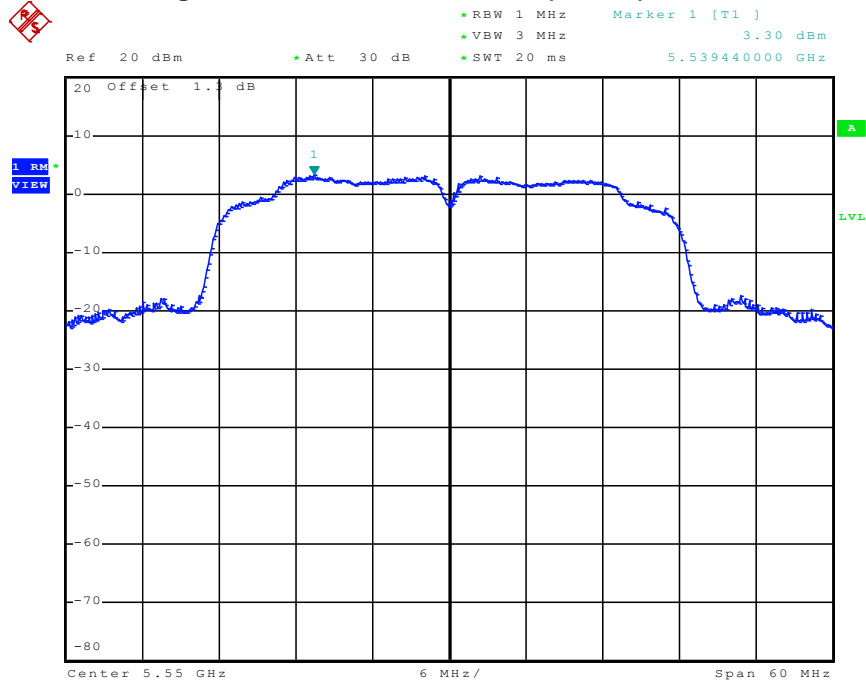

Date: 4.MAY.2011 09:11:52

Power Density Plot on Configuration IEEE 802.11n Ant. A (40MHz) / 5670 MHz

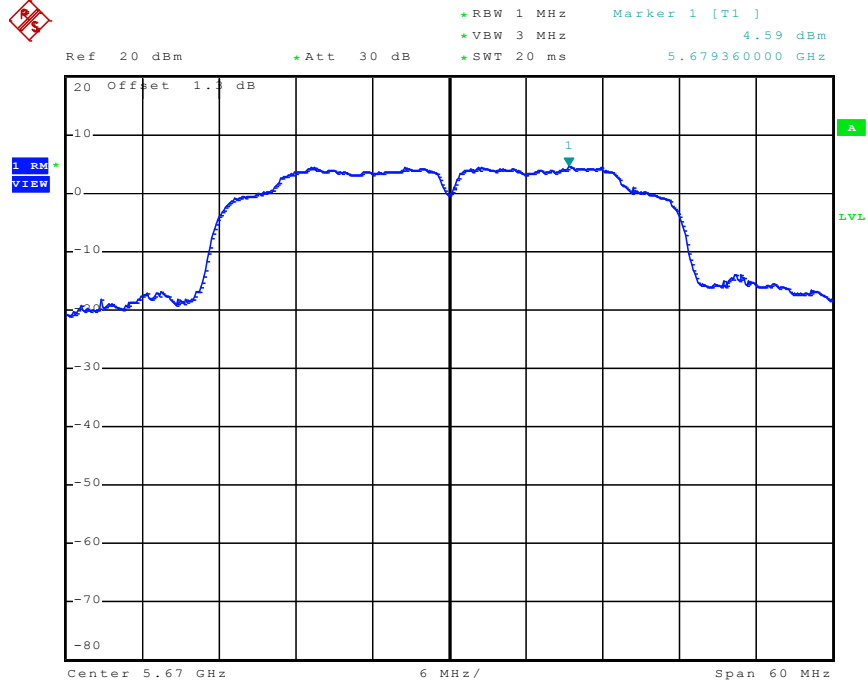

Date: 4.MAY.2011 09:14:34

Power Density Plot on Configuration IEEE 802.11n Ant. B (40MHz) / 5190 MHz

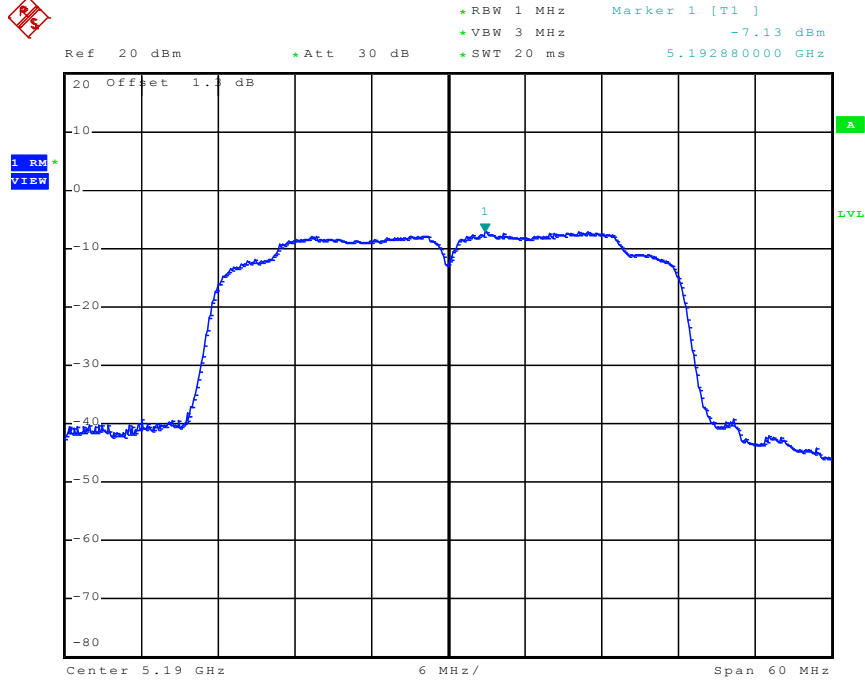

Date: 23.MAY.2011 14:53:36

Power Density Plot on Configuration IEEE 802.11n Ant. B (40MHz) / 5230 MHz

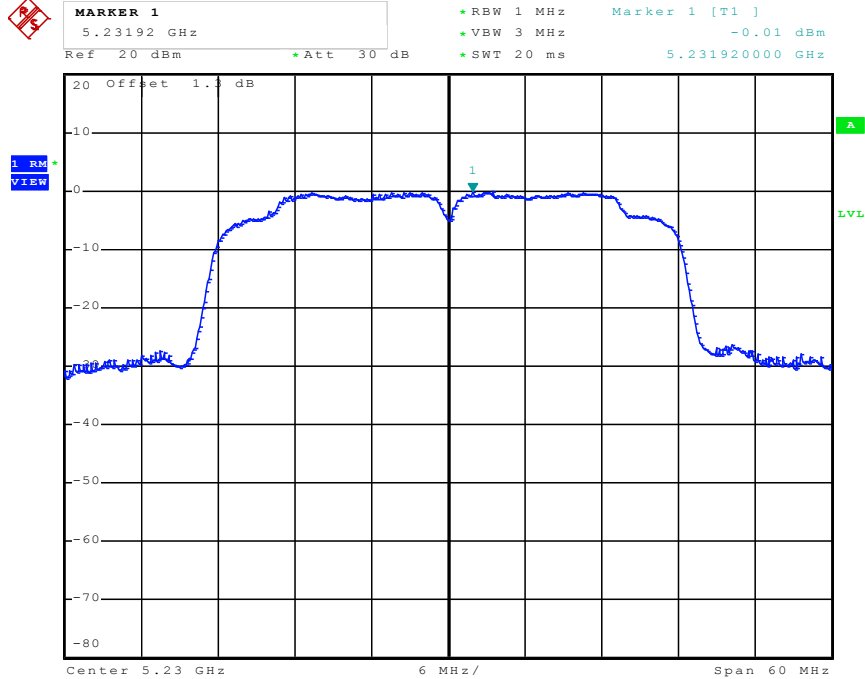

Date: 3.MAY.2011 20:11:35

Power Density Plot on Configuration IEEE 802.11n Ant. B (40MHz) / 5270 MHz

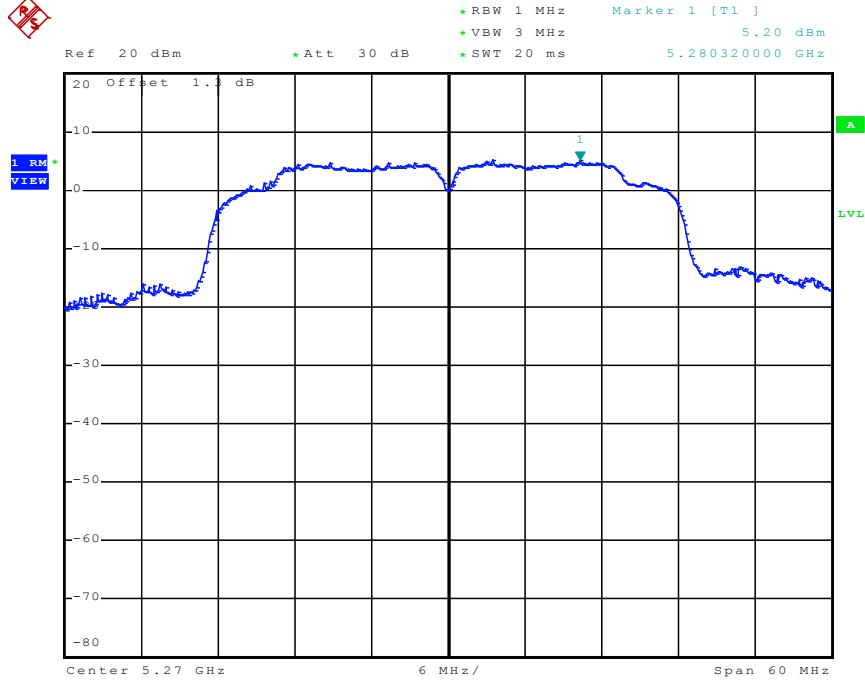

Date: 4.MAY.2011 09:33:40

Power Density Plot on Configuration IEEE 802.11n Ant. B (40MHz) / 5310 MHz

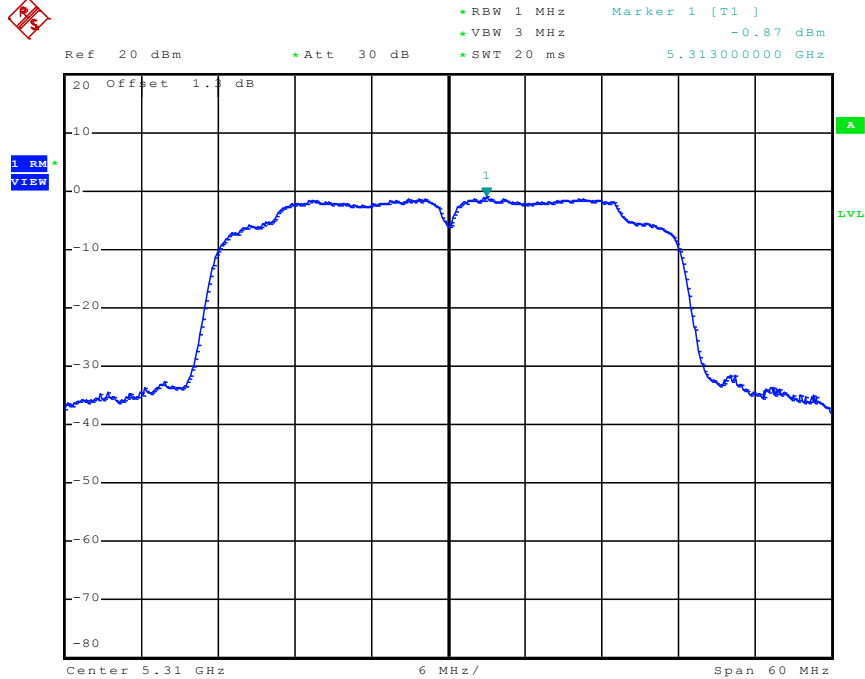

Date: 23.MAY.2011 15:20:31

Power Density Plot on Configuration IEEE 802.11n Ant. B (40MHz) / 5510 MHz

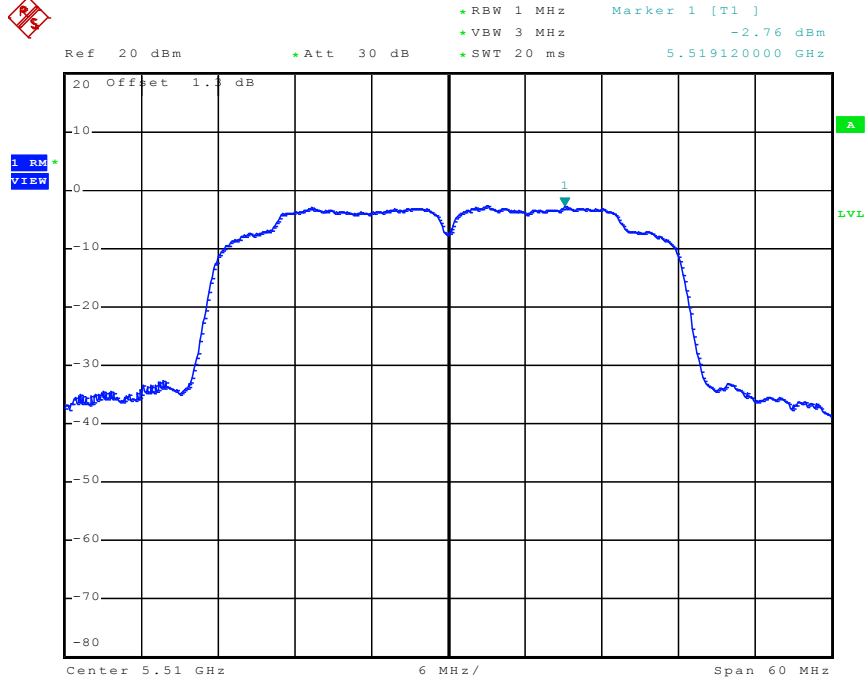

Date: 23.MAY.2011 15:26:33

Power Density Plot on Configuration IEEE 802.11n Ant. B (40MHz) / 5550 MHz

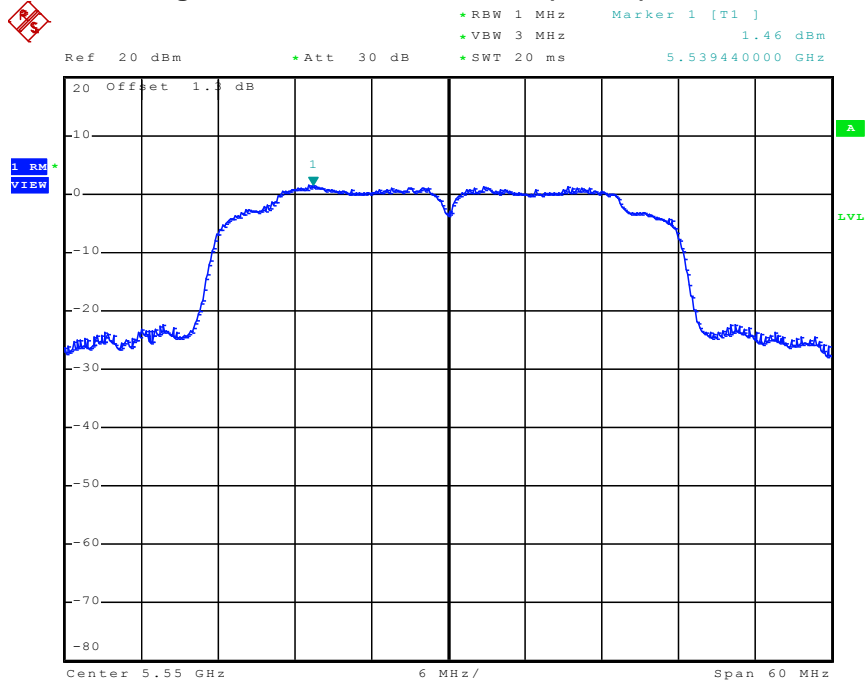

Date: 4.MAY.2011 09:41:55

Power Density Plot on Configuration IEEE 802.11n Ant. B (40MHz) / 5670 MHz

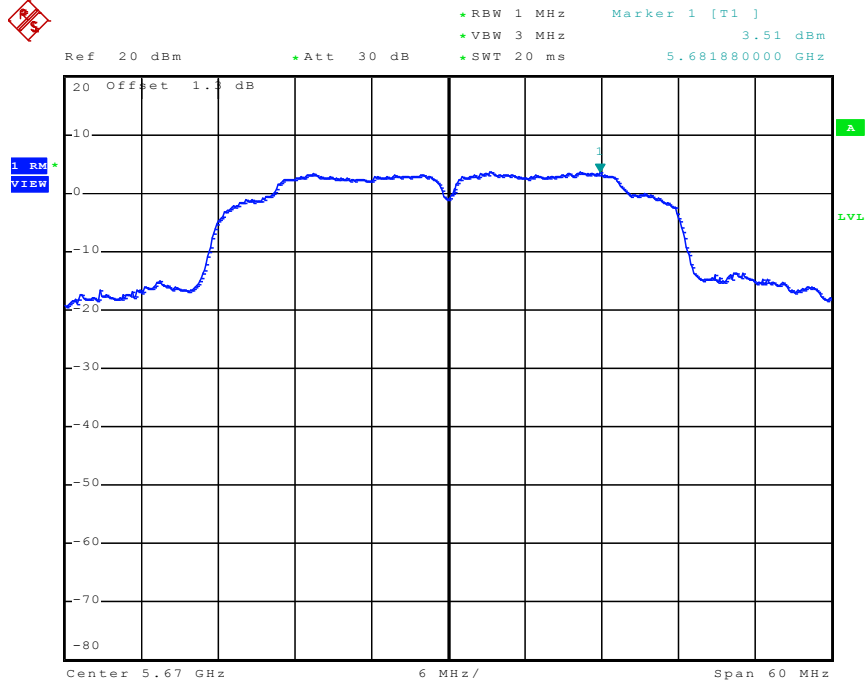

Date: 4.MAY.2011 09:44:24

3.5 Peak Excursion Measurement

3.5.1 Limit

The ratio of the peak excursion of the modulation envelope (measured using a peak hold function) to the maximum conducted output power (measured as specified above) shall not exceed 13 dB across any 1 MHz bandwidth or the emissions bandwidth whichever is less.

3.5.2 Measuring Instruments and Setting

Please refer to section 4 of equipments list in this report. The following table is the setting of the spectrum analyzer.

Spectrum Parameter	Setting
Attenuation	Auto
Span Frequency	Encompass the entire emissions bandwidth (EBW) of the signal
RB	1000 kHz (Peak Trace) / 1000 kHz (Average Trace)
VB	3000 kHz (Peak Trace) / 300 kHz (Average Trace)
Detector	Peak (Peak Trace) / Sample (Average Trace)
Trace	Max Hold
Sweep Time	60s

3.5.3 Test Procedures

1. The transmitter output (antenna port) was connected to the spectrum analyzer.
2. Set the spectrum analyzer span to view the entire emissions bandwidth. The largest difference between the following two traces (Peak Trace and Average Trace) must be ≤ 13 dB for all frequencies across the emissions bandwidth. Submit a plot.
3. Peak Trace: Set RBW = 1 MHz, VBW ≥ 3 MHz with peak detector and max-hold settings.
4. Average Trace: Method #3—video averaging with max hold--and sum power across the band. Set span to encompass the entire emissions bandwidth (EBW) of the signal. Set sweep trigger to "free run". Set RBW = 1 MHz. Set VBW $\geq 1/T$ (IEEE 802.11a VBW = 300kHz $\geq 1/4\mu$ s). Use sample detector mode if bin width (i.e., span/number of points in spectrum) < 0.5 RBW. Otherwise use peak detector mode. Set max hold. Allow max hold to run for 60 seconds.

3.5.4 Test Setup Layout

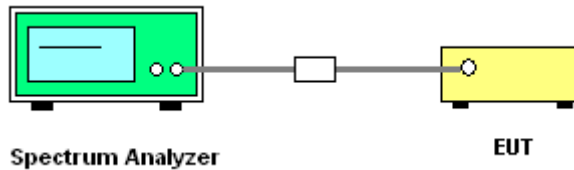

3.5.5 Test Deviation

There is no deviation with the original standard.

3.5.6 EUT Operation during Test

The EUT was programmed to be in continuously transmitting mode.

3.5.7 Test Result of Peak Excursion

Final Test Date	May 23, 2011	Test Site No.	TH01-HY
Temperature	27°C	Humidity	62%
Test Engineer	Ian	Configurations	802.11a/n

**For Single Chain:
Configuration of IEEE 802.11a Ant. A**

Frequency	Peak Excursion (dB)	Max. Limit (dB)	Result
5180 MHz	5.07	13	Complies
5200 MHz	5.29	13	Complies
5240 MHz	4.96	13	Complies
5260 MHz	5.26	13	Complies
5280 MHz	5.24	13	Complies
5320 MHz	5.18	13	Complies
5500 MHz	5.26	13	Complies
5580 MHz	4.83	13	Complies
5700 MHz	5.12	13	Complies

Configuration IEEE 802.11n Ant. A (20MHz)

Frequency	Peak Excursion (dB)	Max. Limit (dB)	Result
5180 MHz	5.06	13	Complies
5200 MHz	5.23	13	Complies
5240 MHz	4.88	13	Complies
5260 MHz	5.29	13	Complies
5280 MHz	5.02	13	Complies
5320 MHz	5.09	13	Complies
5500 MHz	5.27	13	Complies
5580 MHz	5.12	13	Complies
5700 MHz	4.42	13	Complies

Configuration IEEE 802.11n Ant. A (40MHz)

Frequency	Peak Excursion (dB)	Max. Limit (dB)	Result
5190 MHz	5.45	13	Complies
5230 MHz	5.16	13	Complies
5270 MHz	5.14	13	Complies
5310 MHz	5.26	13	Complies
5510 MHz	5.34	13	Complies
5550 MHz	4.41	13	Complies
5670 MHz	5.23	13	Complies

**For Two Chain:
Configuration IEEE 802.11n (20MHz) Ant. A**

Frequency	Peak Excursion (dB)	Max. Limit (dB)	Result
5180 MHz	8.31	13	Complies
5200 MHz	6.26	13	Complies
5240 MHz	5.72	13	Complies
5260 MHz	7.46	13	Complies
5280 MHz	6.62	13	Complies
5320 MHz	6.35	13	Complies
5500 MHz	6.58	13	Complies
5580 MHz	6.65	13	Complies
5700 MHz	6.40	13	Complies

Configuration IEEE 802.11n (20MHz) Ant. B

Frequency	Peak Excursion (dB)	Max. Limit (dB)	Result
5180 MHz	7.24	13	Complies
5200 MHz	6.86	13	Complies
5240 MHz	6.58	13	Complies
5260 MHz	6.80	13	Complies
5280 MHz	6.76	13	Complies
5320 MHz	6.45	13	Complies
5500 MHz	6.77	13	Complies
5580 MHz	6.84	13	Complies
5700 MHz	6.65	13	Complies

Configuration IEEE 802.11n (40MHz) Ant. A

Frequency	Peak Excursion (dB)	Max. Limit (dB)	Result
5190 MHz	6.44	13	Complies
5230 MHz	6.56	13	Complies
5270 MHz	6.58	13	Complies
5310 MHz	7.18	13	Complies
5510 MHz	6.49	13	Complies
5550 MHz	6.51	13	Complies
5670 MHz	6.58	13	Complies

Configuration IEEE 802.11n (40MHz) Ant. B

Frequency	Peak Excursion (dB)	Max. Limit (dB)	Result
5190 MHz	6.58	13	Complies
5230 MHz	7.12	13	Complies
5270 MHz	6.18	13	Complies
5310 MHz	6.69	13	Complies
5510 MHz	6.79	13	Complies
5550 MHz	6.53	13	Complies
5670 MHz	6.48	13	Complies

For Single Chain:
Peak Excursion Plot on Configuration IEEE 802.11a Ant. A / 5180 MHz

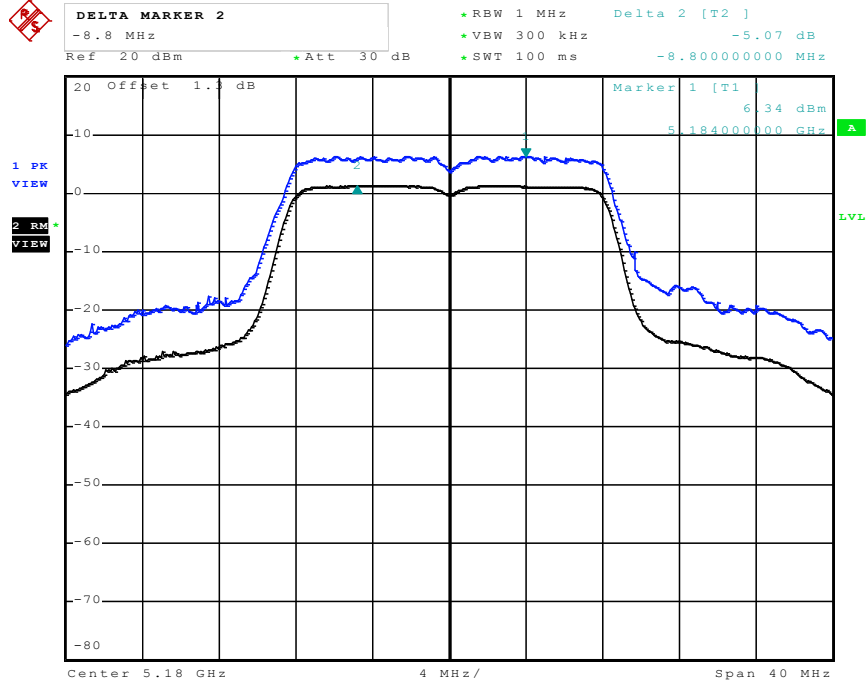

Date: 23.MAY.2011 11:20:30

Peak Excursion Plot on Configuration IEEE 802.11a Ant. A / 5200 MHz

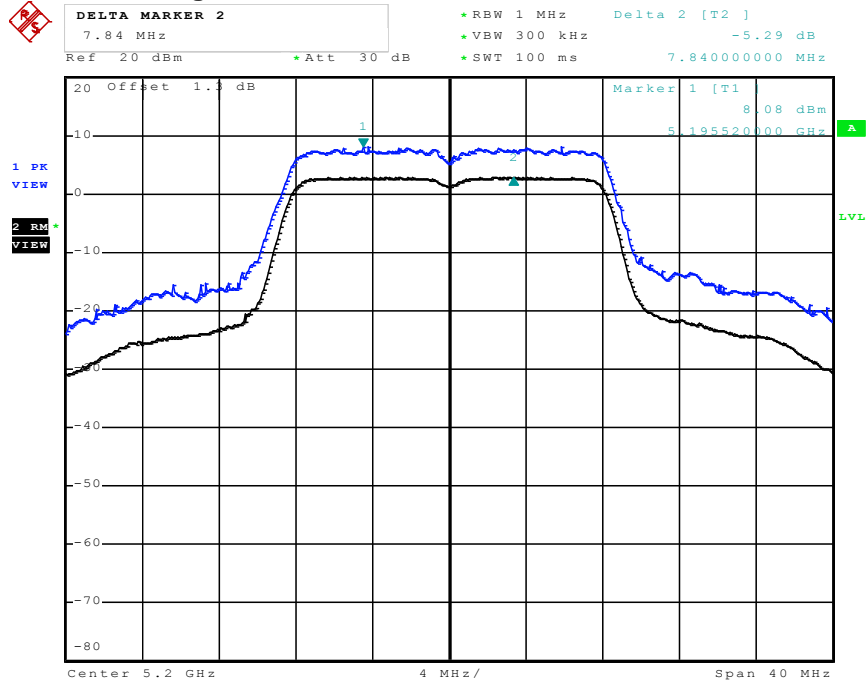

Date: 3.MAY.2011 11:53:43

Peak Excursion Plot on Configuration IEEE 802.11a Ant. A / 5240 MHz

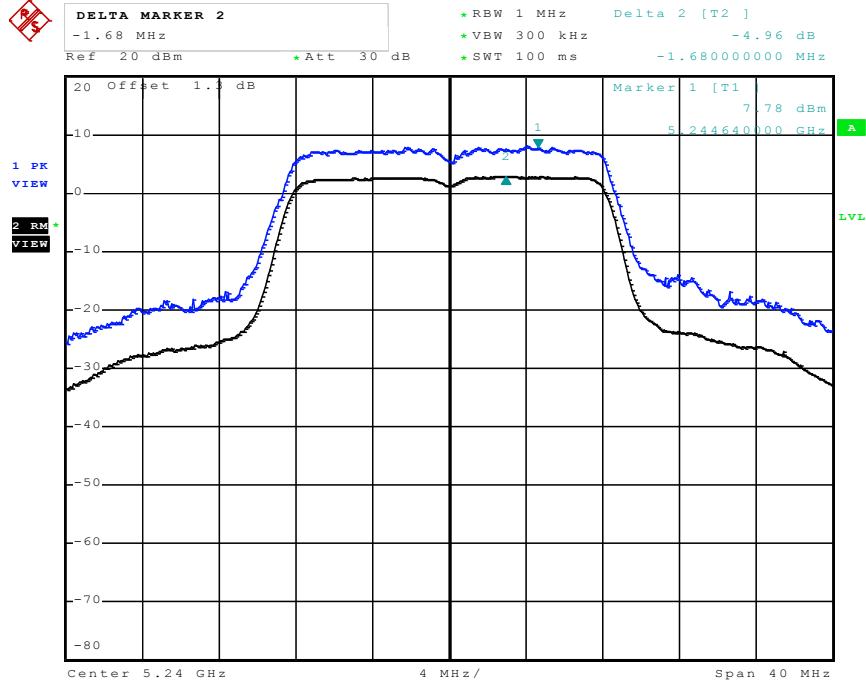

Date: 3.MAY.2011 11:57:26

Peak Excursion Plot on Configuration IEEE 802.11a Ant. A / 5260 MHz

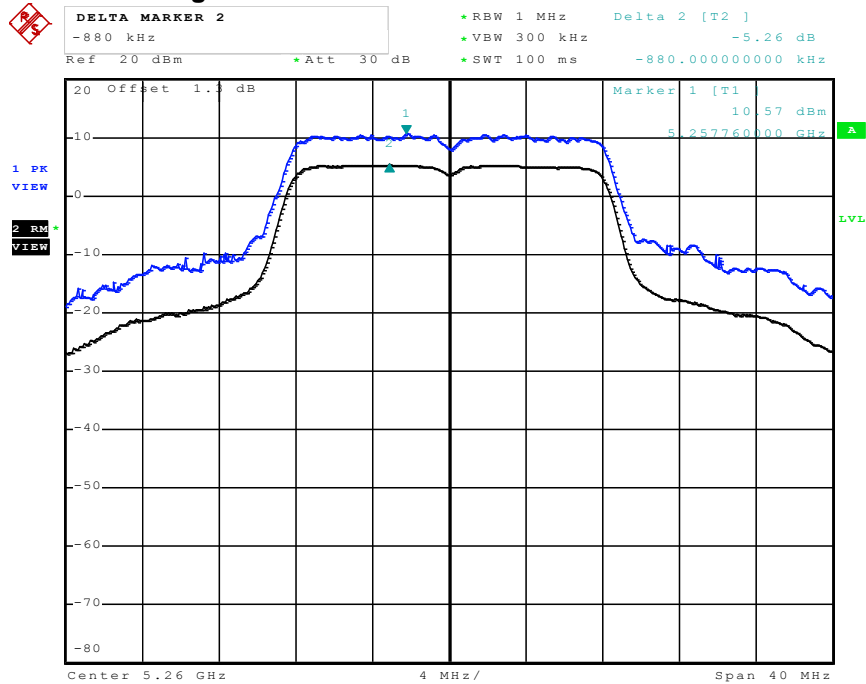

Date: 3.MAY.2011 12:01:30

Peak Excursion Plot on Configuration IEEE 802.11a Ant. A / 5280 MHz

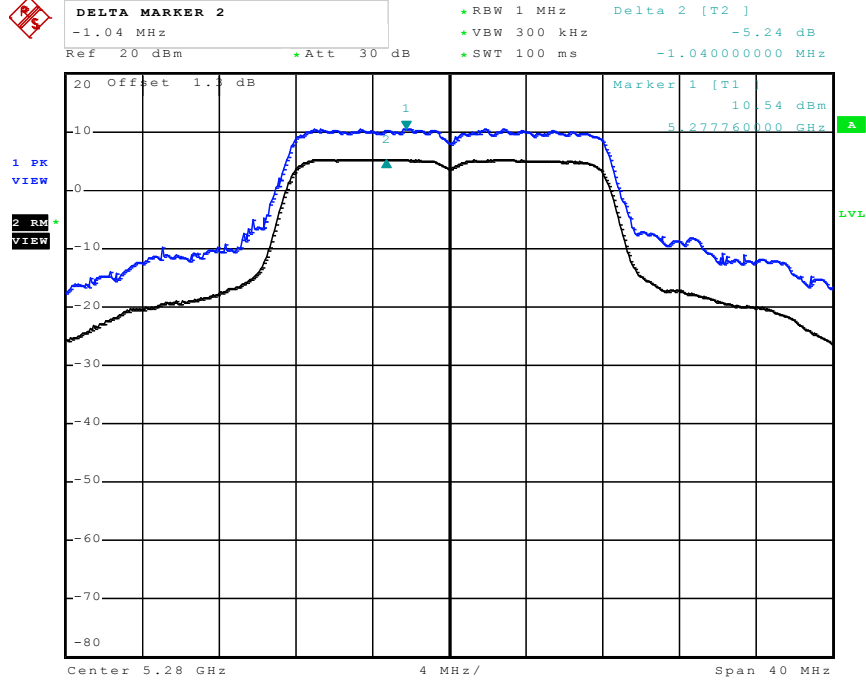

Date: 3.MAY.2011 12:07:04

Peak Excursion Plot on Configuration IEEE 802.11a Ant. A / 5320 MHz

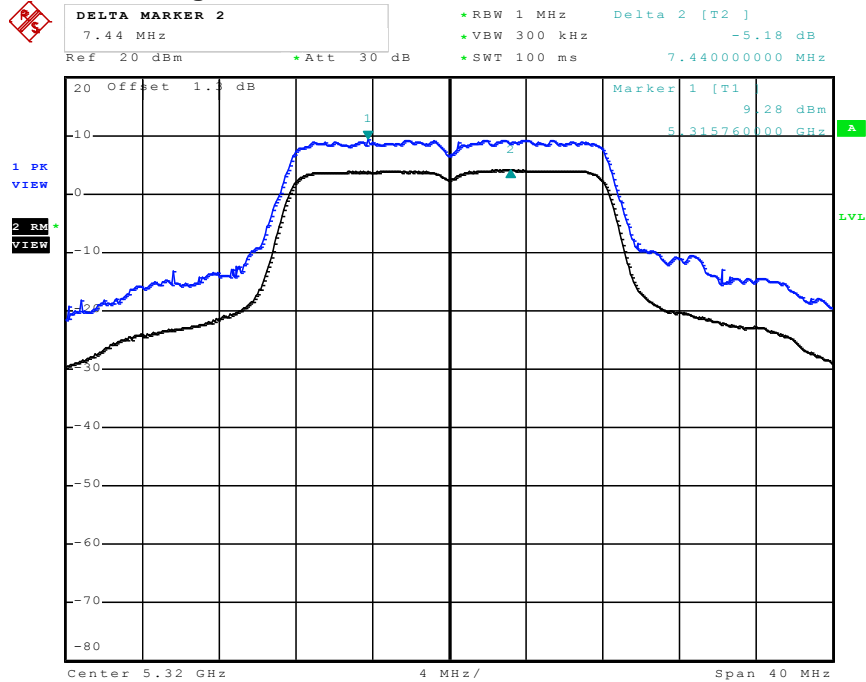

Date: 23.MAY.2011 11:35:30

Peak Excursion Plot on Configuration IEEE 802.11a Ant. A / 5500 MHz

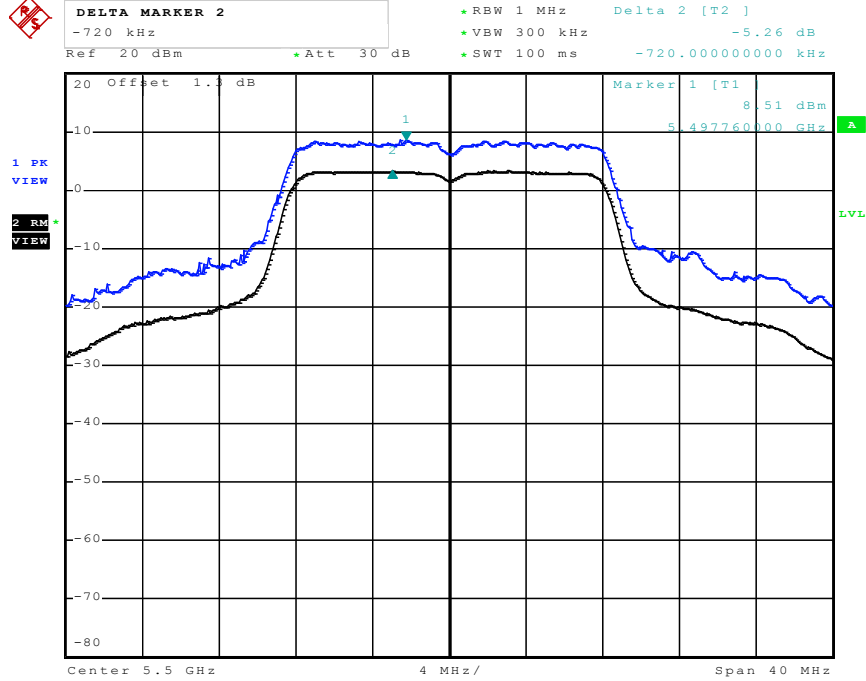

Date: 3.MAY.2011 12:12:38

Peak Excursion Plot on Configuration IEEE 802.11a Ant. A / 5580 MHz

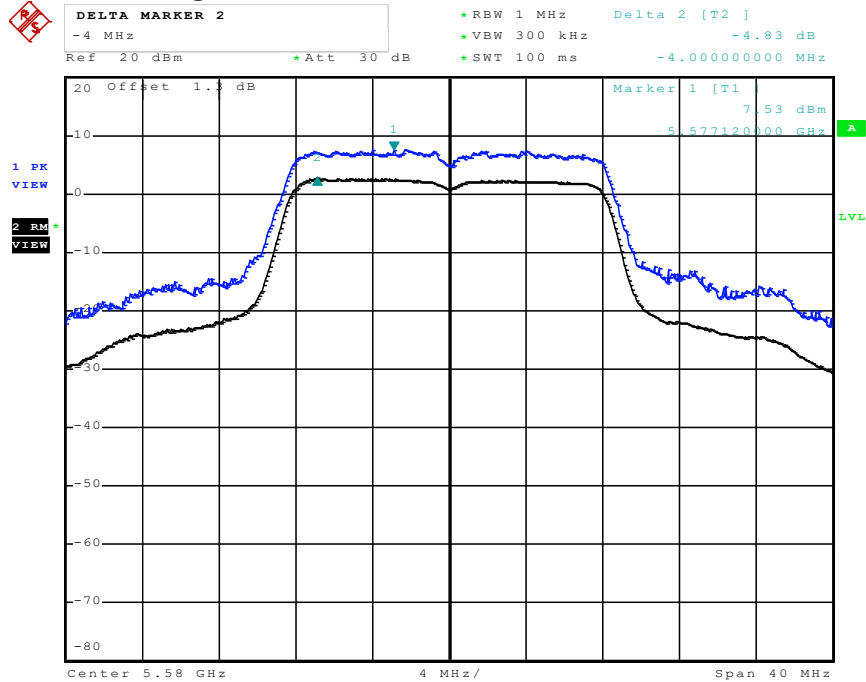

Date: 3.MAY.2011 12:15:46

Peak Excursion Plot on Configuration IEEE 802.11a Ant. A / 5700 MHz

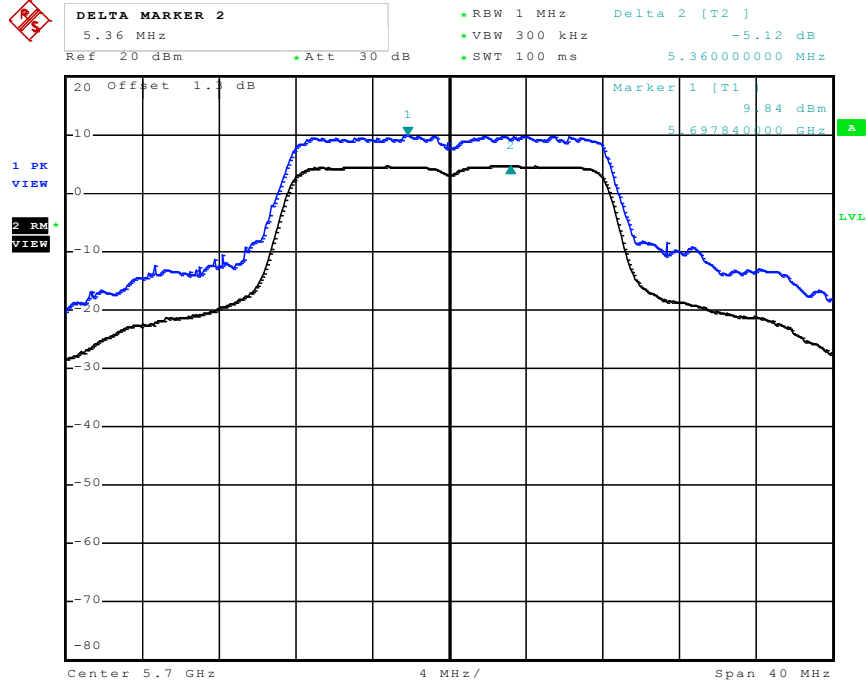

Date: 3.MAY.2011 12:18:30

Peak Excursion Plot on Configuration IEEE 802.11n Ant. A (20MHz) / 5180 MHz

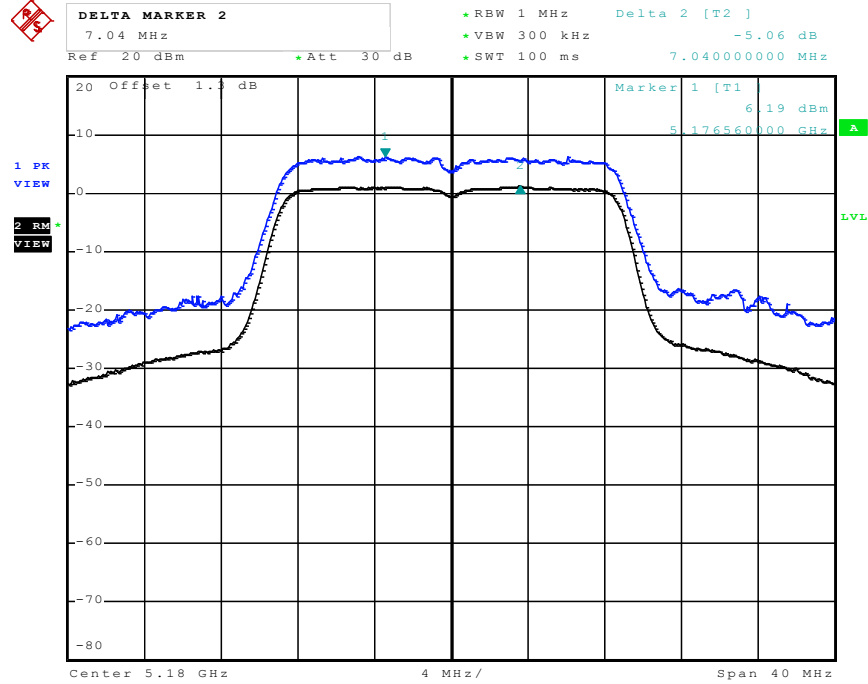

Date: 23.MAY.2011 11:49:32

Peak Excursion Plot on Configuration IEEE 802.11n Ant. A (20MHz) / 5200 MHz

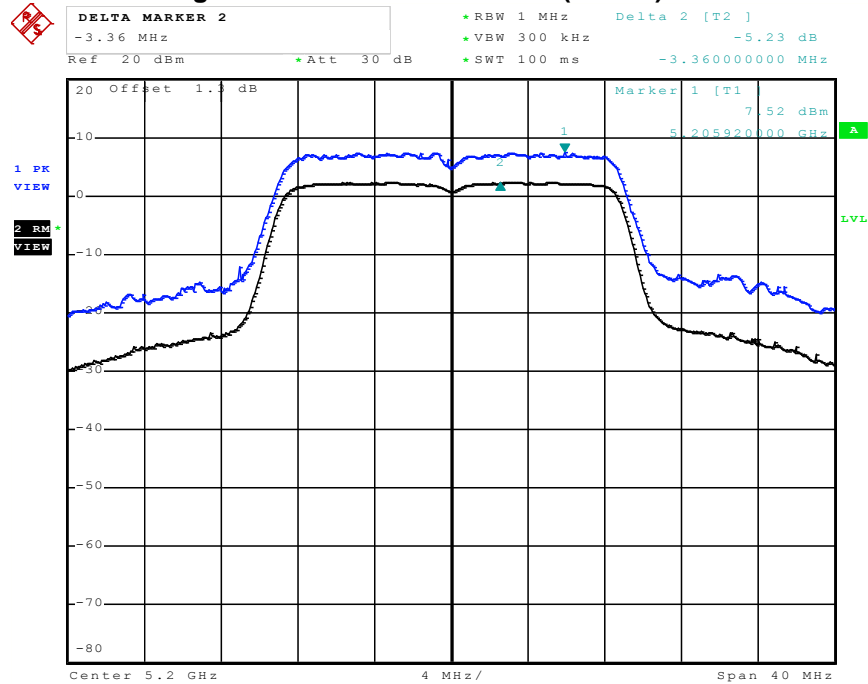

Date: 3.MAY.2011 14:31:02

Peak Excursion Plot on Configuration IEEE 802.11n Ant. A (20MHz) / 5240 MHz

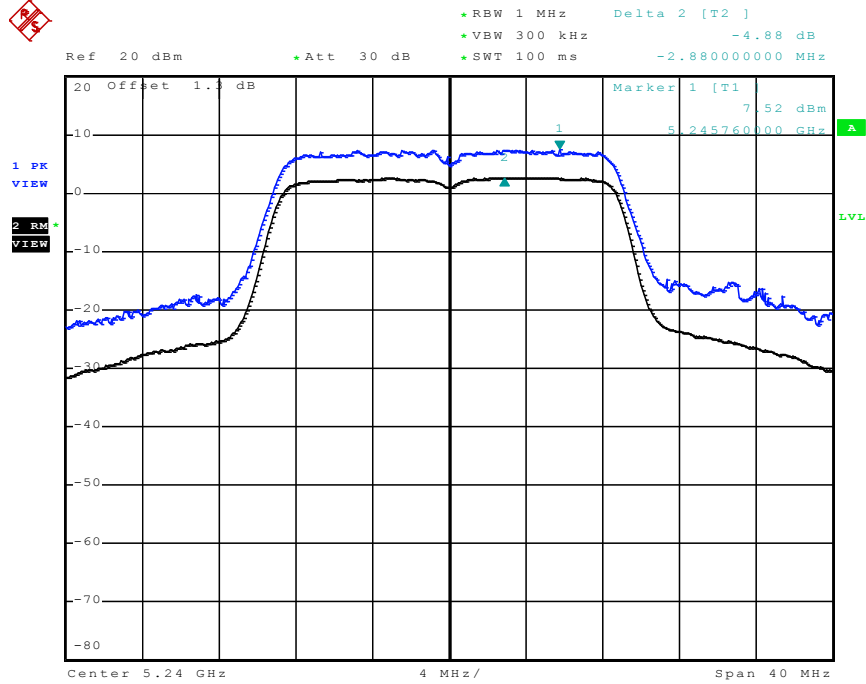

Date: 3.MAY.2011 14:34:02

Peak Excursion Plot on Configuration IEEE 802.11n Ant. A (20MHz) / 5260 MHz

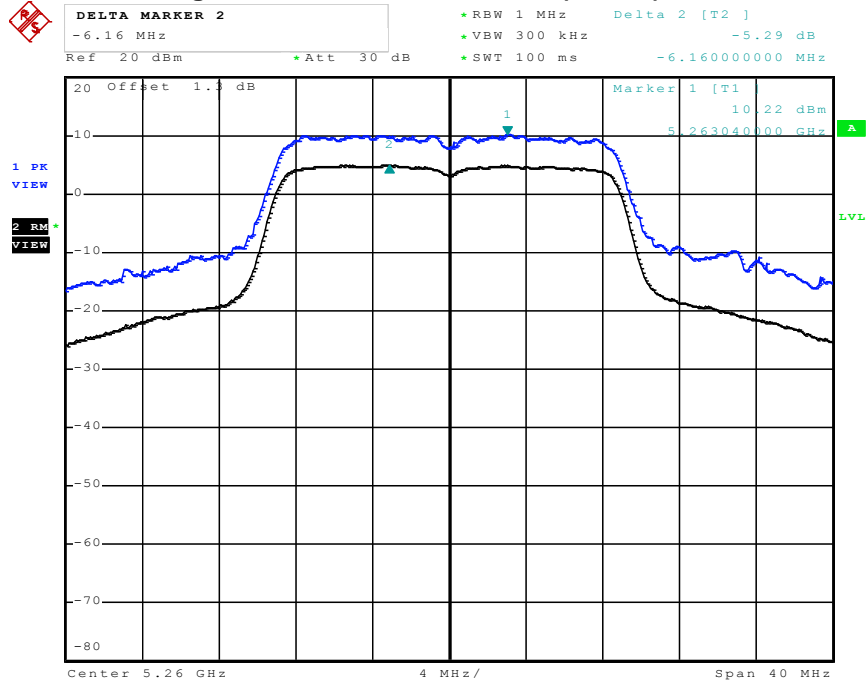

Date: 3.MAY.2011 14:47:59

Peak Excursion Plot on Configuration IEEE 802.11n Ant. A (20MHz) / 5280 MHz

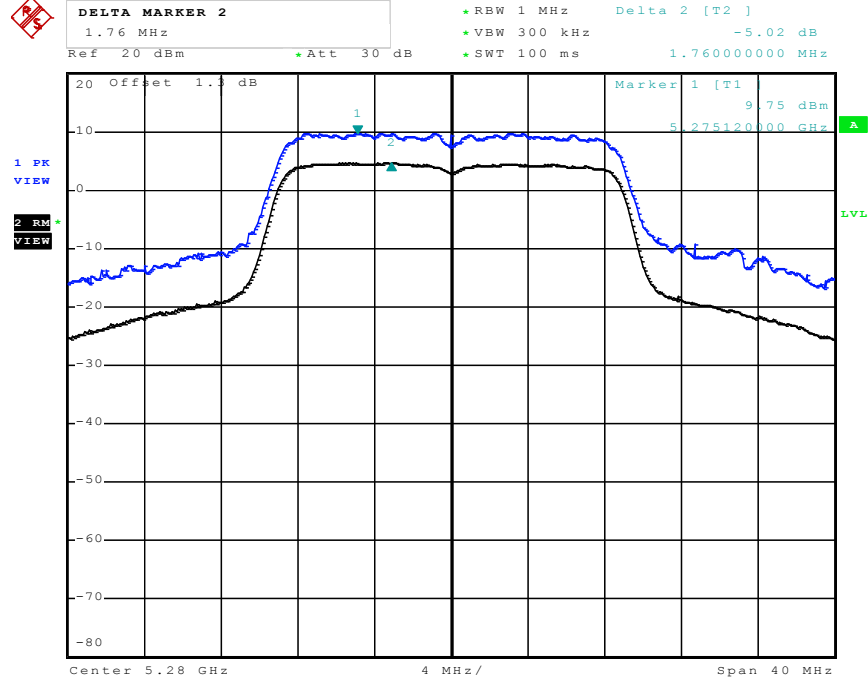

Date: 3.MAY.2011 14:50:52

Peak Excursion Plot on Configuration IEEE 802.11n Ant. A (20MHz) / 5320 MHz

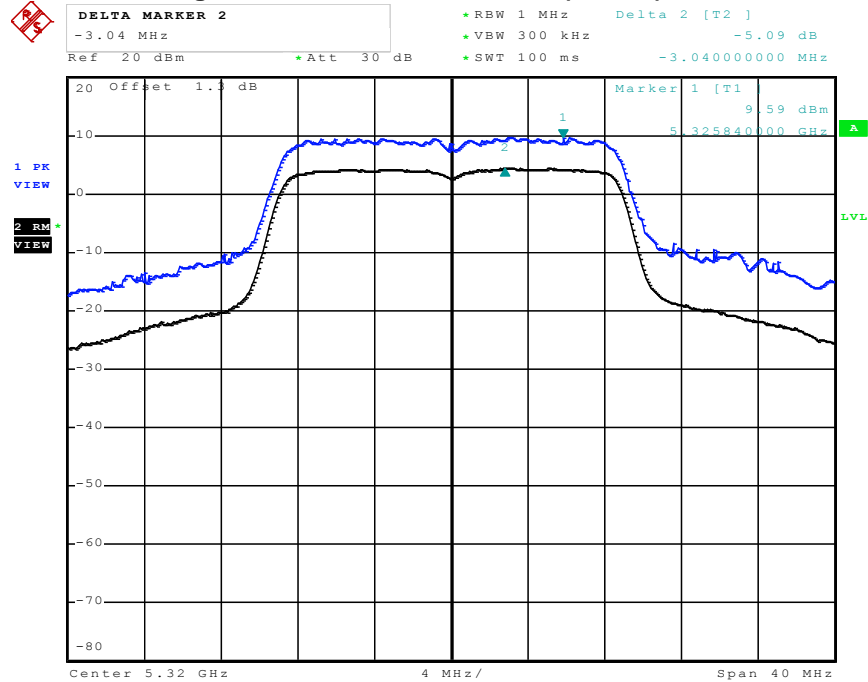

Date: 23.MAY.2011 12:03:22

Peak Excursion Plot on Configuration IEEE 802.11n Ant. A (20MHz) / 5500 MHz

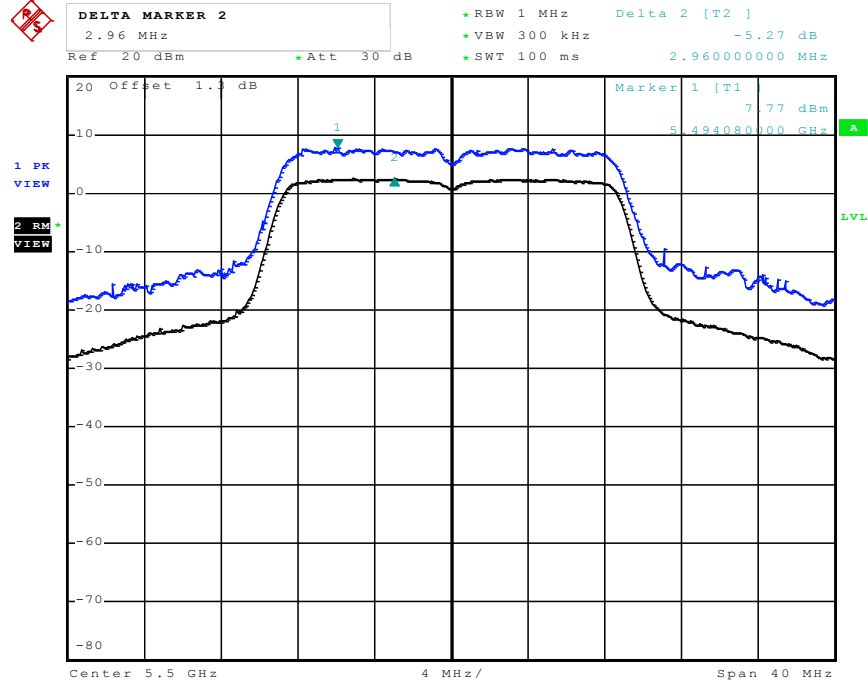

Date: 3.MAY.2011 14:57:12

Peak Excursion Plot on Configuration IEEE 802.11n Ant. A (20MHz) / 5580 MHz

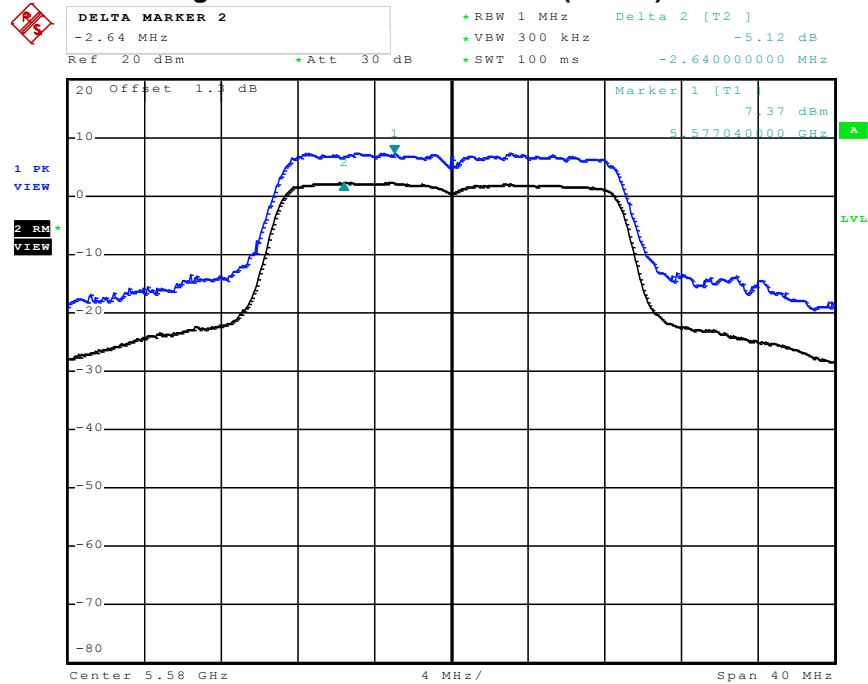

Date: 3.MAY.2011 15:01:37

Peak Excursion Plot on Configuration IEEE 802.11n Ant. A (20MHz) / 5700 MHz

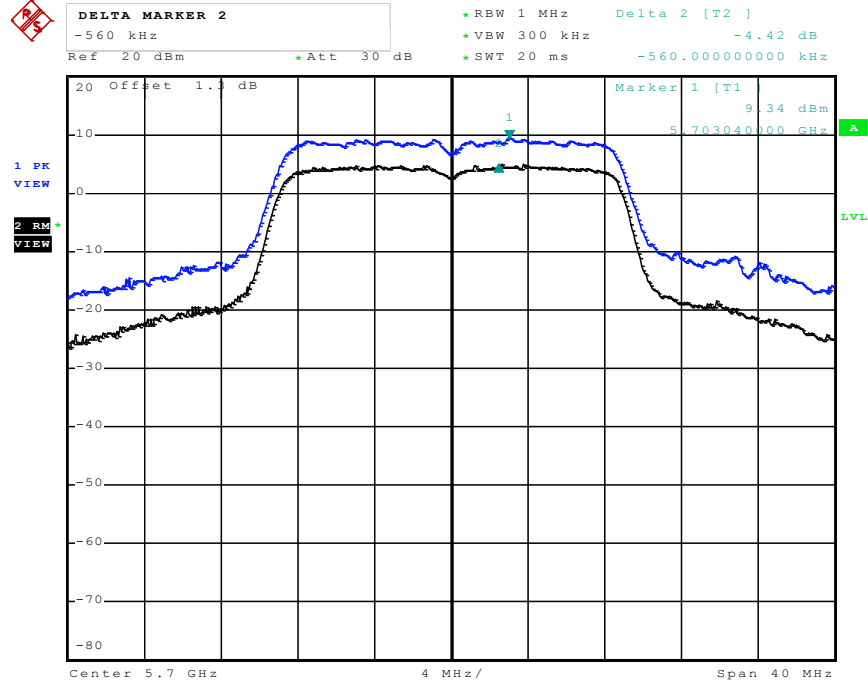

Date: 3.MAY.2011 15:05:20

Peak Excursion Plot on Configuration IEEE 802.11n Ant. A (40MHz) / 5190 MHz

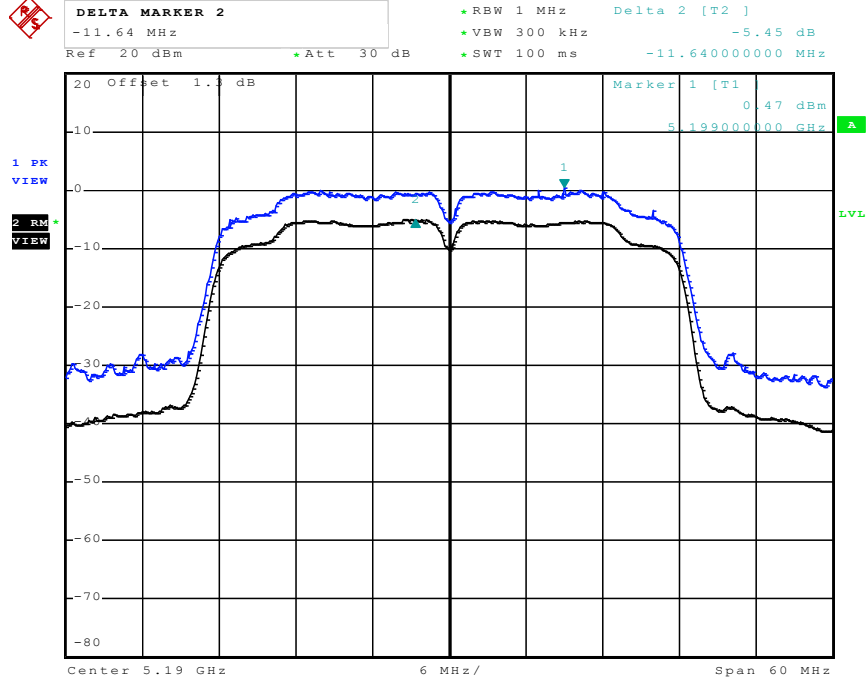

Date: 23.MAY.2011 12:09:29

Peak Excursion Plot on Configuration IEEE 802.11n Ant. A (40MHz) / 5230 MHz

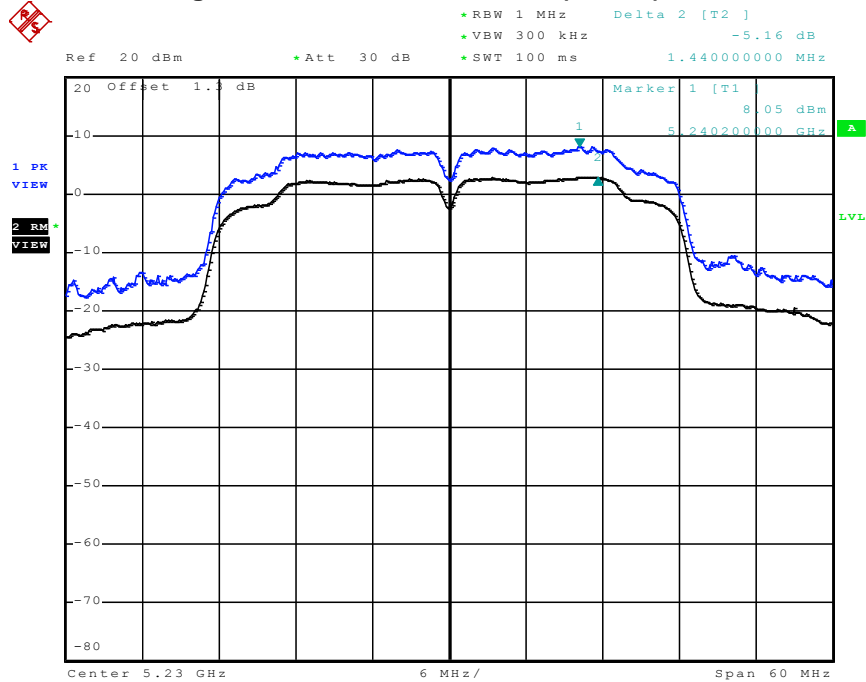

Date: 3.MAY.2011 16:10:00

Peak Excursion Plot on Configuration IEEE 802.11n Ant. A (40MHz) / 5270 MHz

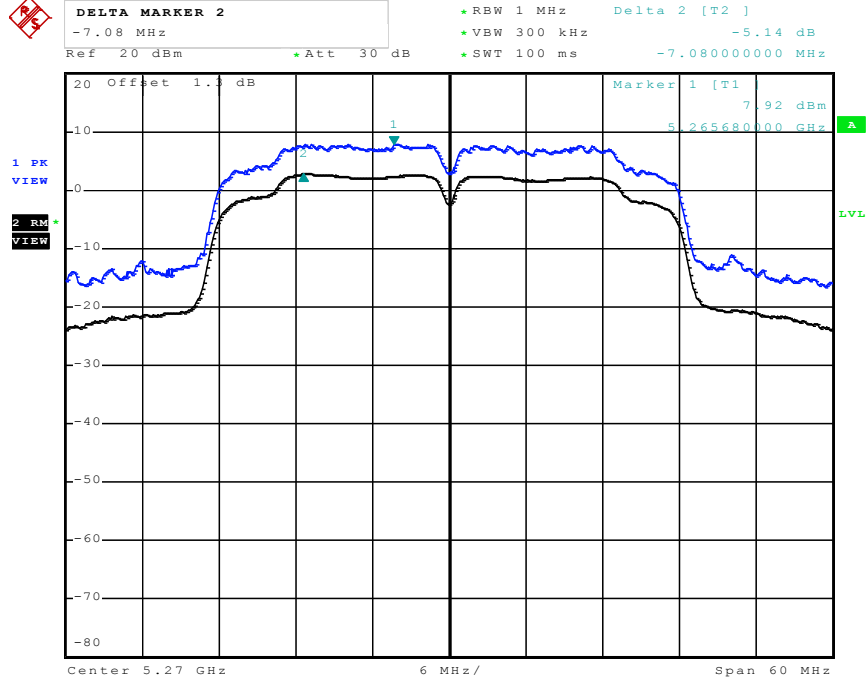

Date: 3.MAY.2011 16:12:48

Peak Excursion Plot on Configuration IEEE 802.11n Ant. A (40MHz) / 5310 MHz

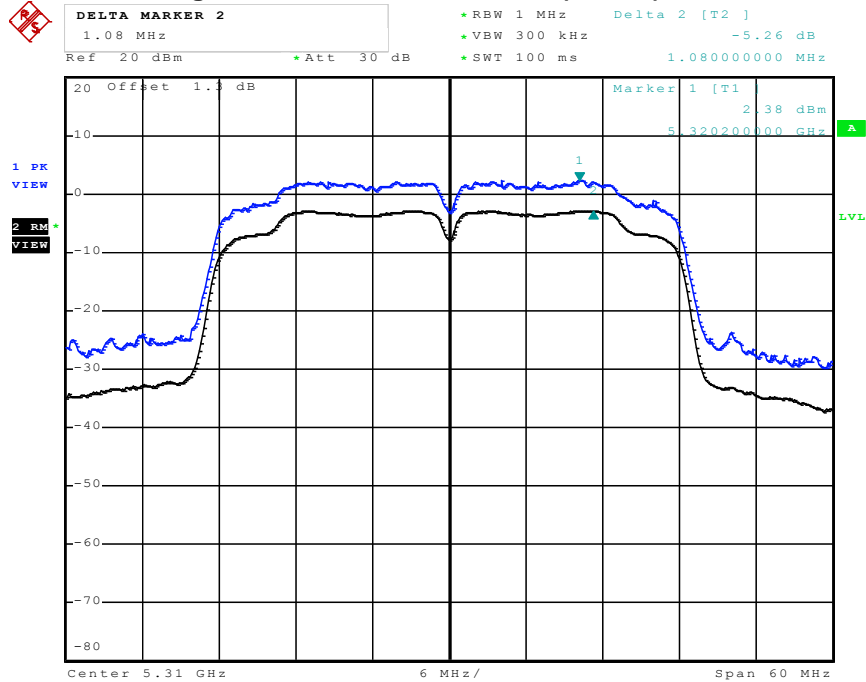

Date: 23.MAY.2011 12:13:29

Peak Excursion Plot on Configuration IEEE 802.11n Ant. A (40MHz) / 5510 MHz

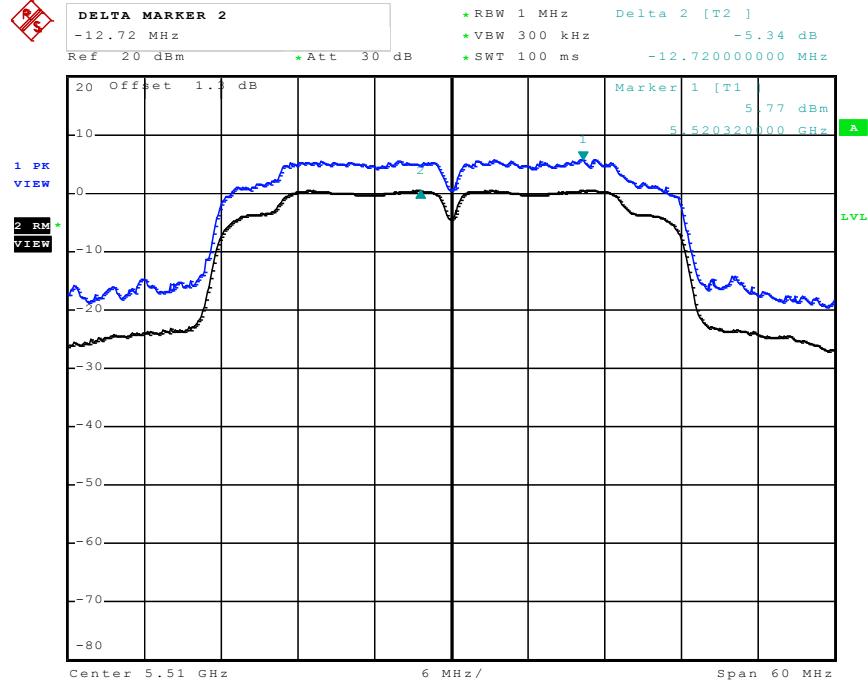

Date: 3.MAY.2011 16:18:19

Peak Excursion Plot on Configuration IEEE 802.11n Ant. A (40MHz) / 5550 MHz

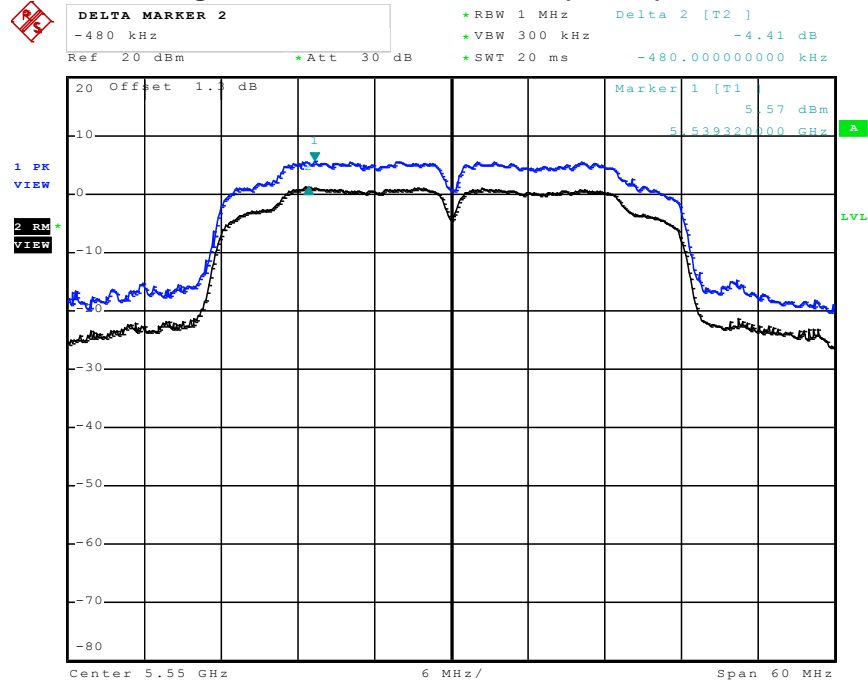

Date: 3.MAY.2011 16:21:11

Peak Excursion Plot on Configuration IEEE 802.11n Ant. A (40MHz) / 5670 MHz

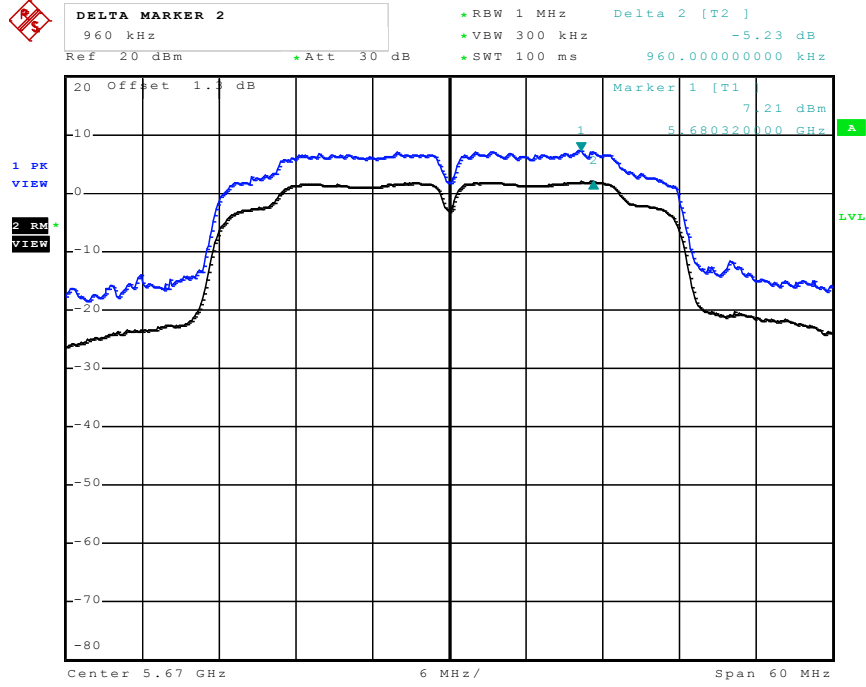

Date: 3.MAY.2011 16:23:58

For Two Chain:
Peak Excursion Plot on Configuration IEEE 802.11n Ant. A (20MHz) / 5180 MHz

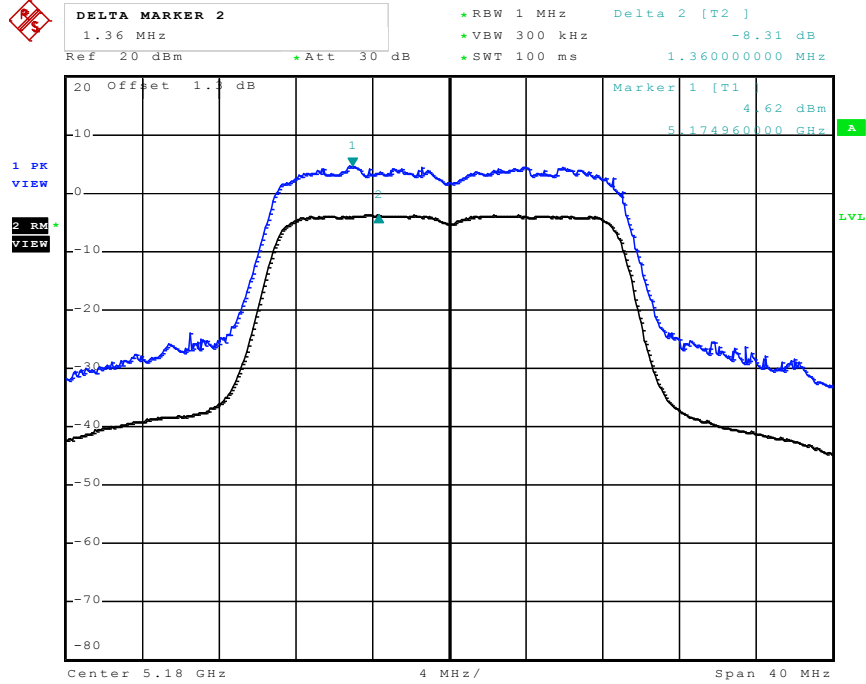

Date: 3.MAY.2011 20:29:15

Peak Excursion Plot on Configuration IEEE 802.11n Ant. A (20MHz) / 5200 MHz

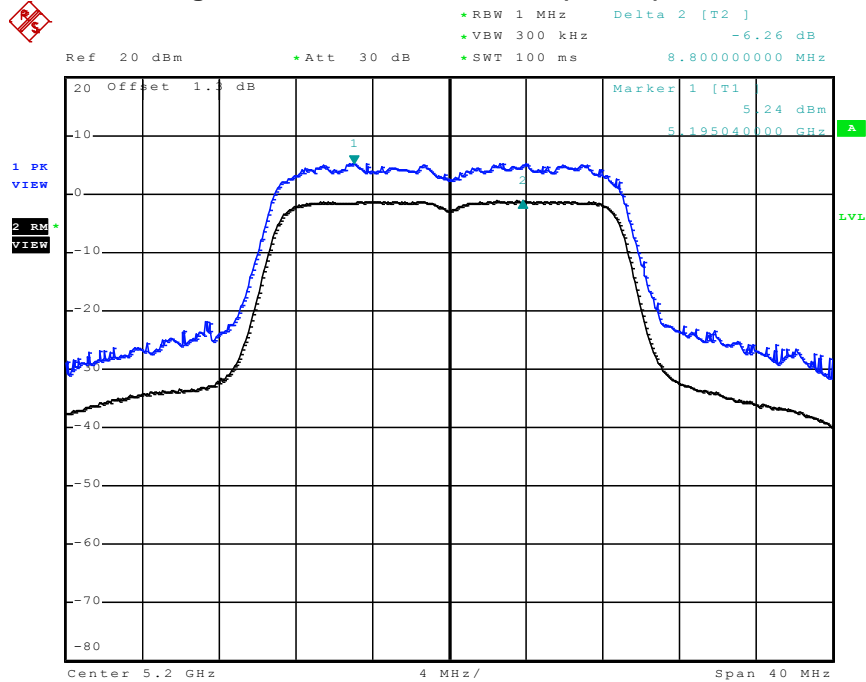

Date: 3.MAY.2011 20:31:24

Peak Excursion Plot on Configuration IEEE 802.11n Ant. A (20MHz) / 5240 MHz

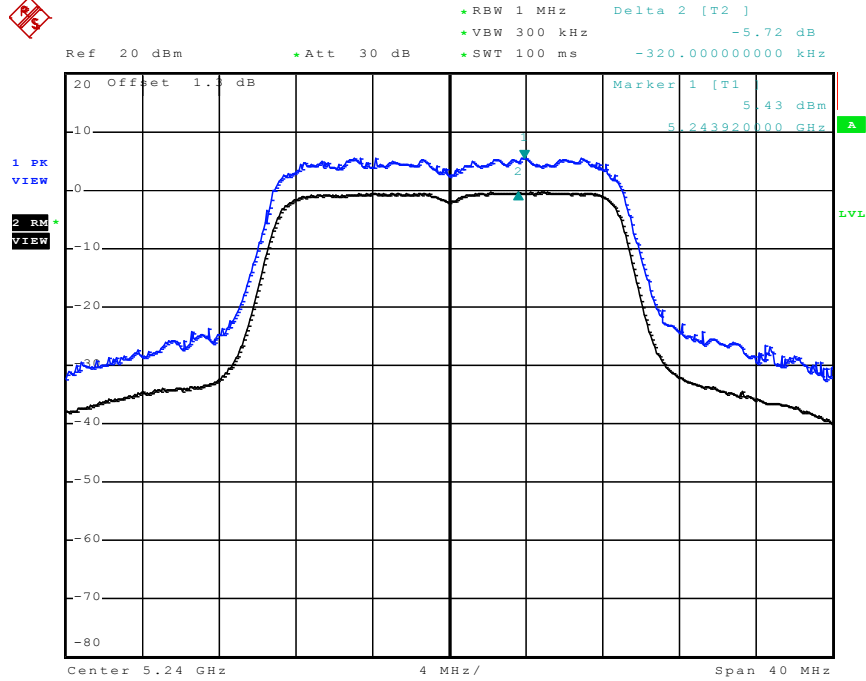

Date: 3.MAY.2011 20:33:55

Peak Excursion Plot on Configuration IEEE 802.11n Ant. A (20MHz) / 5260 MHz

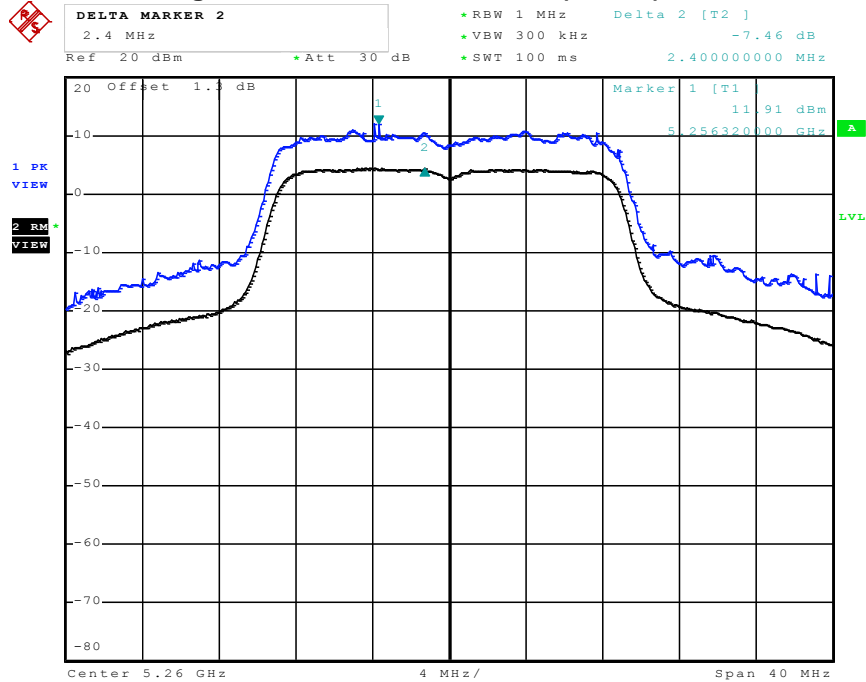

Date: 3.MAY.2011 20:38:09

Peak Excursion Plot on Configuration IEEE 802.11n Ant. A (20MHz) / 5280 MHz

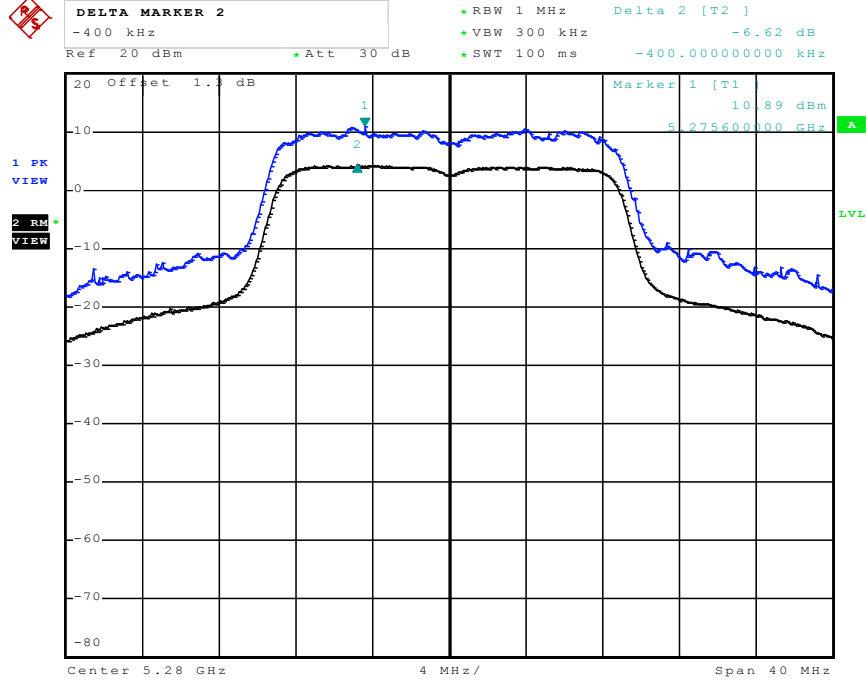

Date: 3.MAY.2011 20:40:45

Peak Excursion Plot on Configuration IEEE 802.11n Ant. A (20MHz) / 5320 MHz

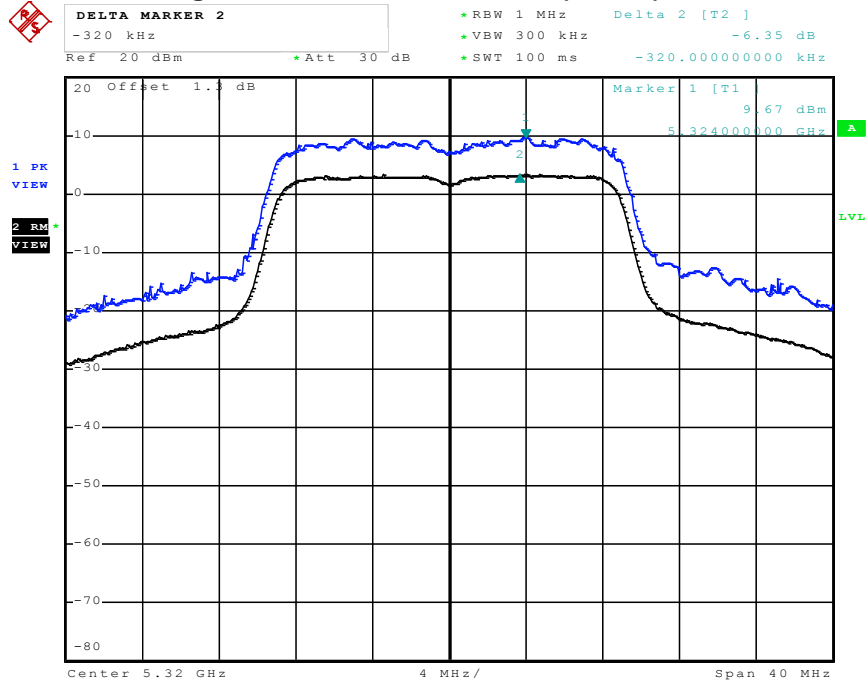

Date: 23.MAY.2011 14:36:03

Peak Excursion Plot on Configuration IEEE 802.11n Ant. A (20MHz) / 5500 MHz

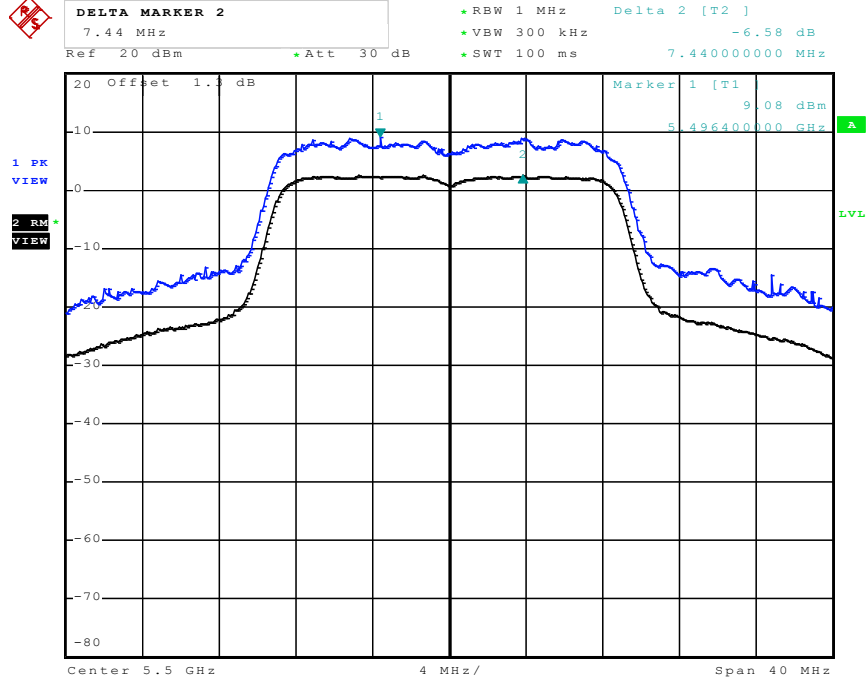

Date: 3.MAY.2011 20:46:00

Peak Excursion Plot on Configuration IEEE 802.11n Ant. A (20MHz) / 5580 MHz

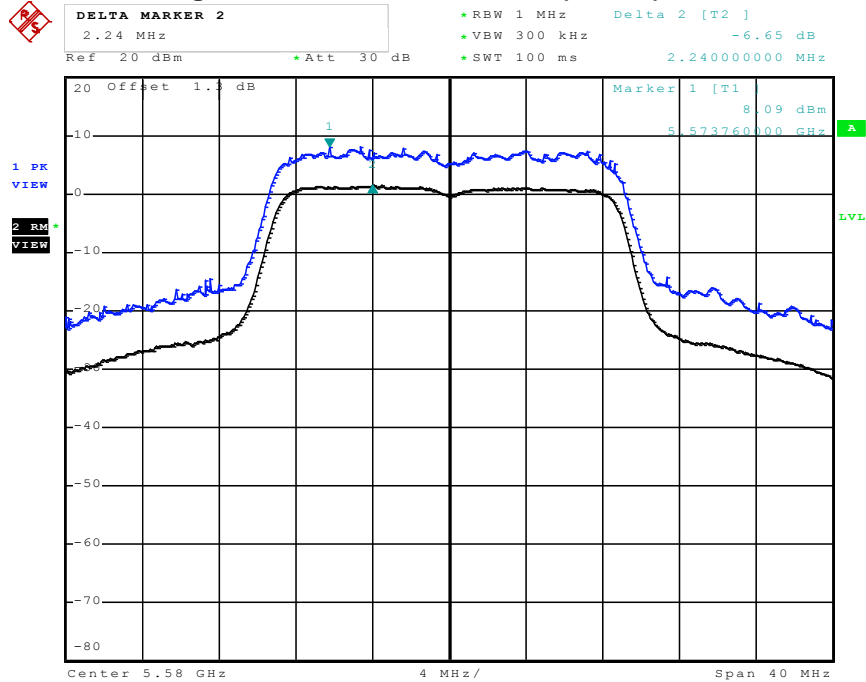

Date: 3.MAY.2011 20:49:00

Peak Excursion Plot on Configuration IEEE 802.11n Ant. A (20MHz) / 5700 MHz

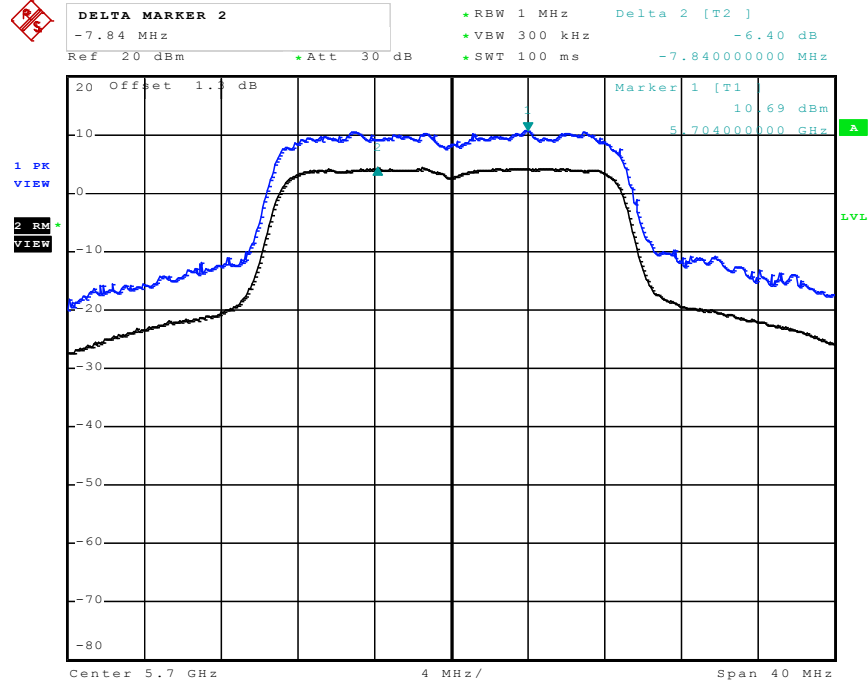

Peak Excursion Plot on Configuration IEEE 802.11n Ant. B (20MHz) / 5180 MHz

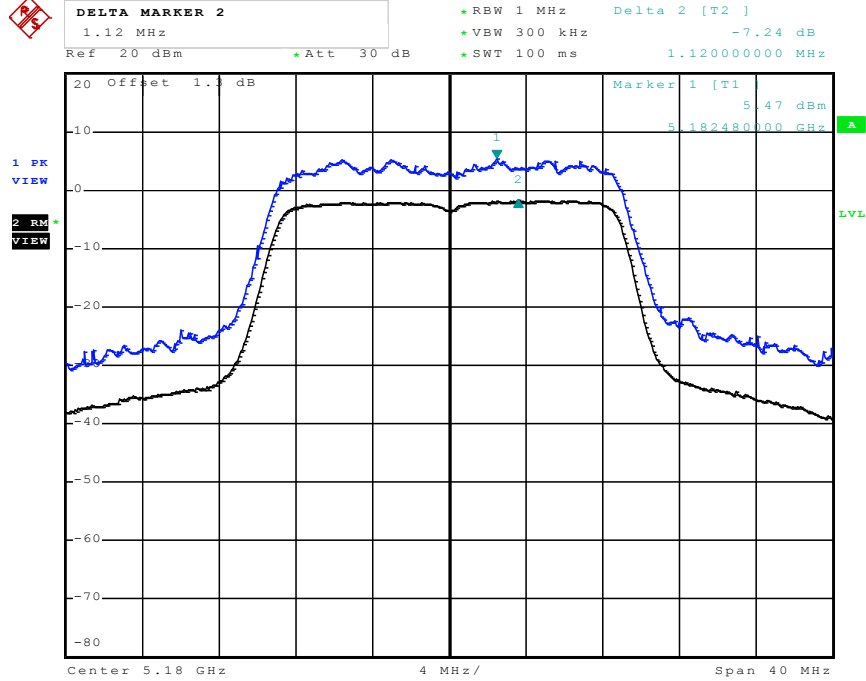

Date: 3.MAY.2011 21:25:42

Peak Excursion Plot on Configuration IEEE 802.11n Ant. B (20MHz) / 5200 MHz

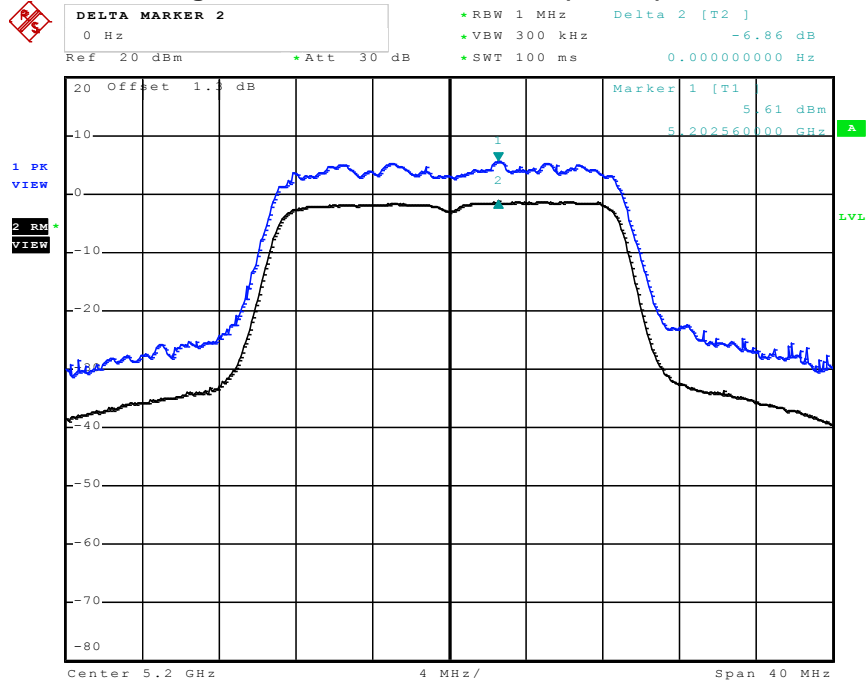

Date: 3.MAY.2011 21:27:57

Peak Excursion Plot on Configuration IEEE 802.11n Ant. B (20MHz) / 5240 MHz

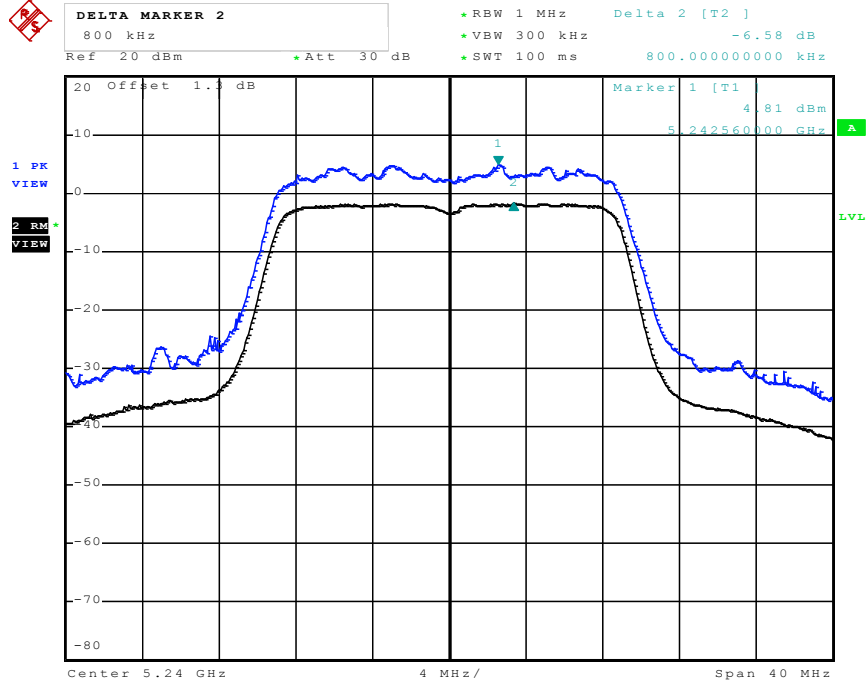

Date: 3.MAY.2011 21:30:06

Peak Excursion Plot on Configuration IEEE 802.11n Ant. B (20MHz) / 5260 MHz

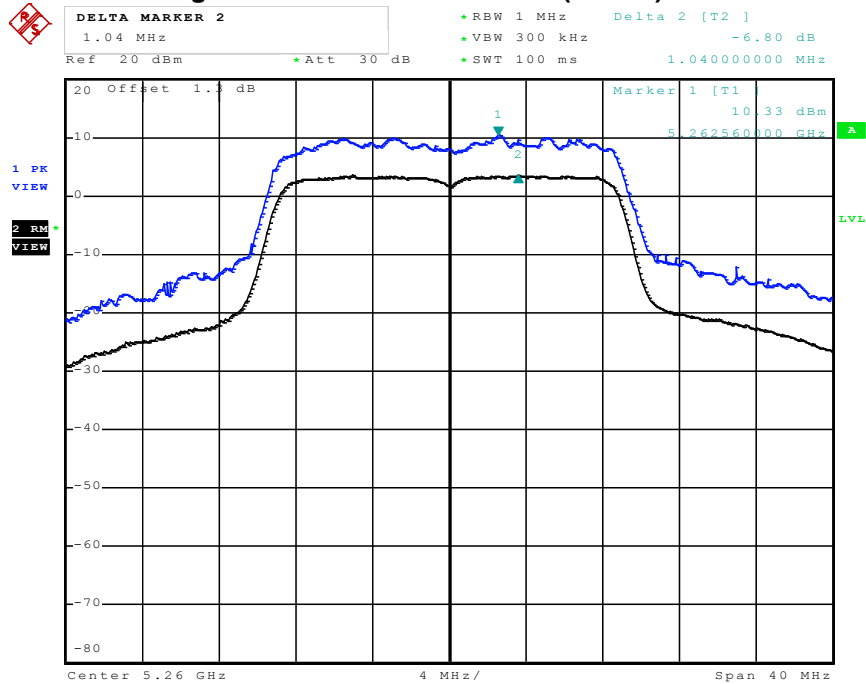

Date: 3.MAY.2011 22:21:52

Peak Excursion Plot on Configuration IEEE 802.11n Ant. B (20MHz) / 5280 MHz

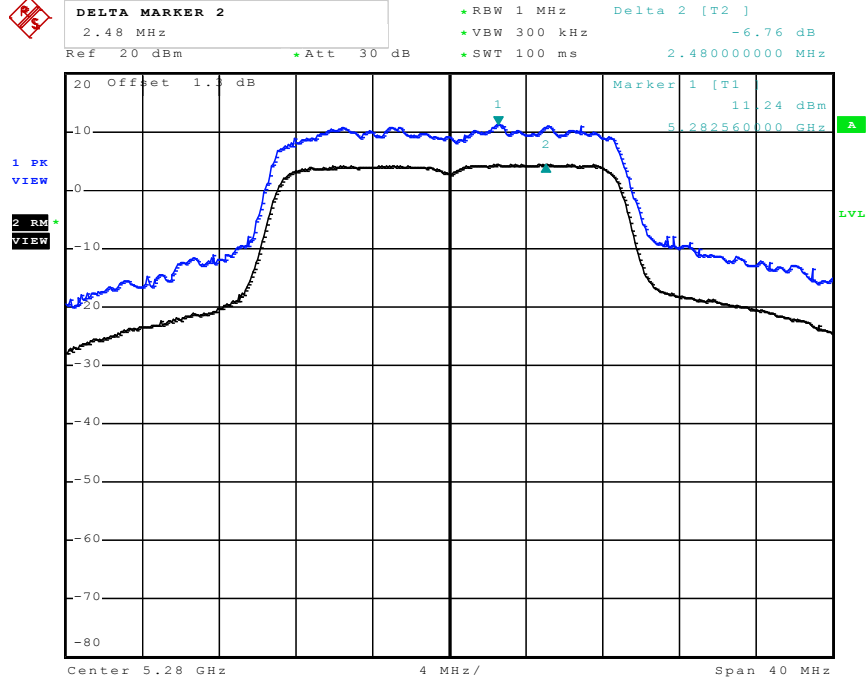

Date: 3.MAY.2011 22:26:08

Peak Excursion Plot on Configuration IEEE 802.11n Ant. B (20MHz) / 5320 MHz

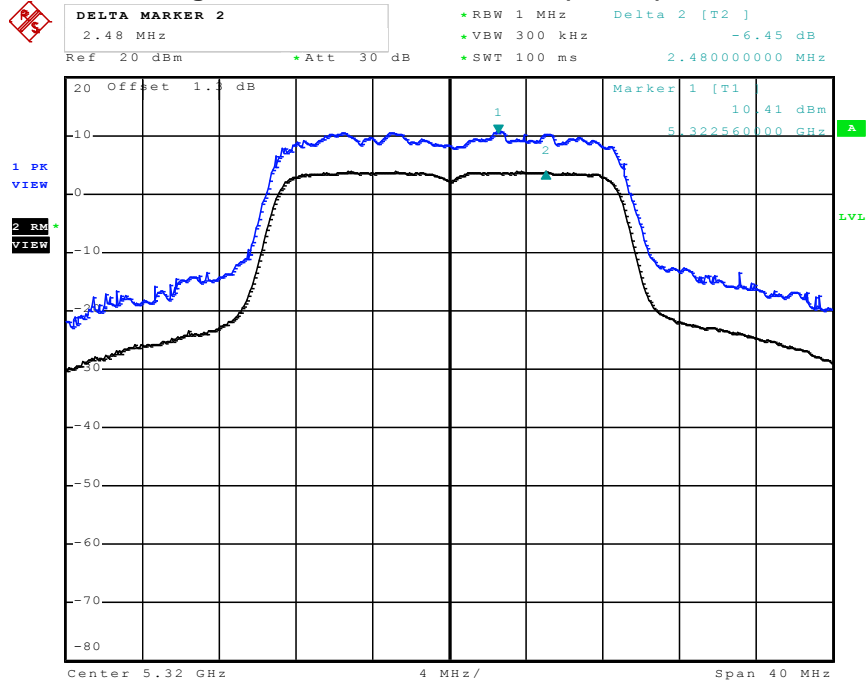

Date: 23.MAY.2011 14:46:33

Peak Excursion Plot on Configuration IEEE 802.11n Ant. B (20MHz) / 5500 MHz

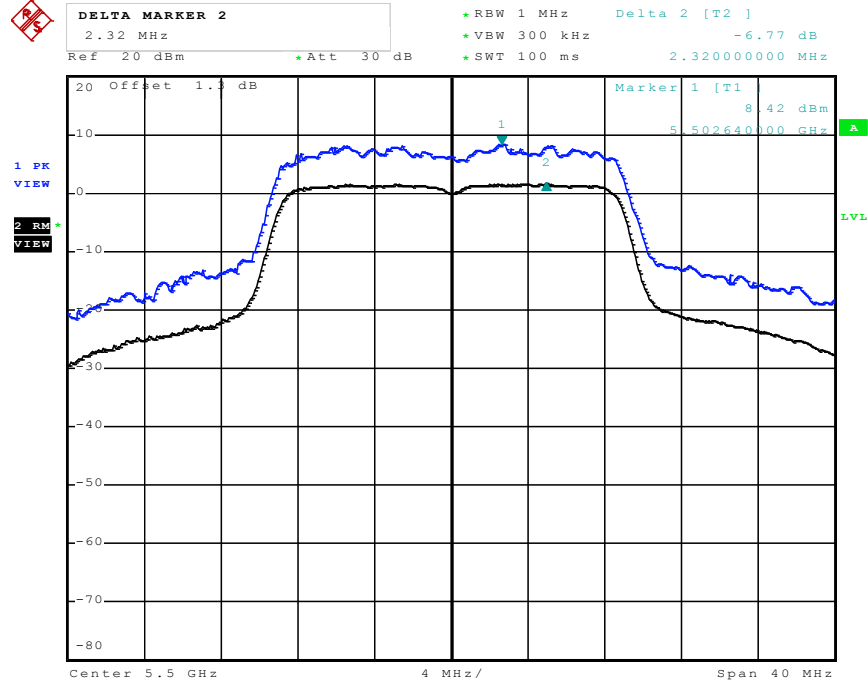

Date: 3.MAY.2011 21:45:15

Peak Excursion Plot on Configuration IEEE 802.11n Ant. B (20MHz) / 5580 MHz

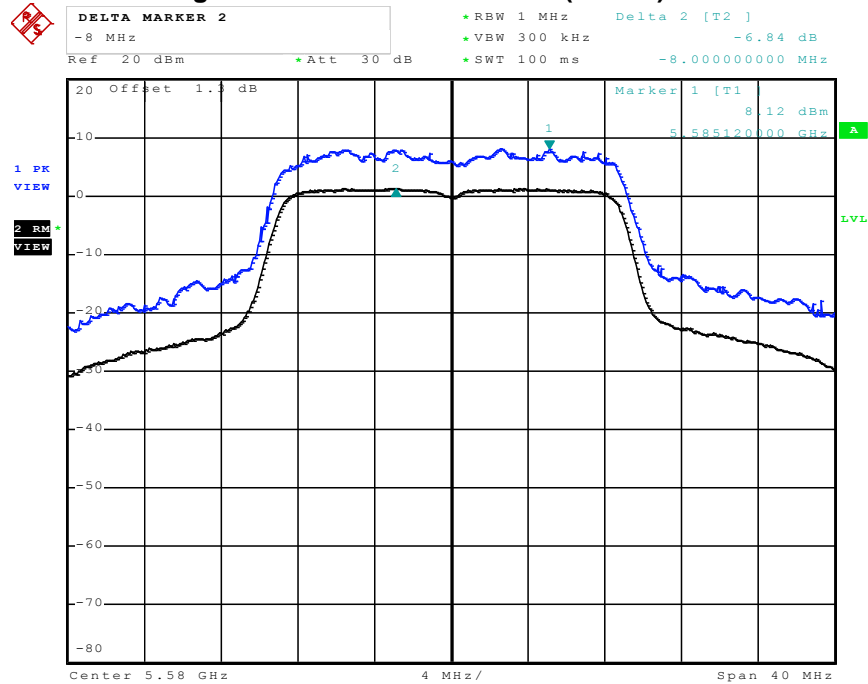

Date: 3.MAY.2011 21:47:36

Peak Excursion Plot on Configuration IEEE 802.11n Ant. B (20MHz) / 5700 MHz

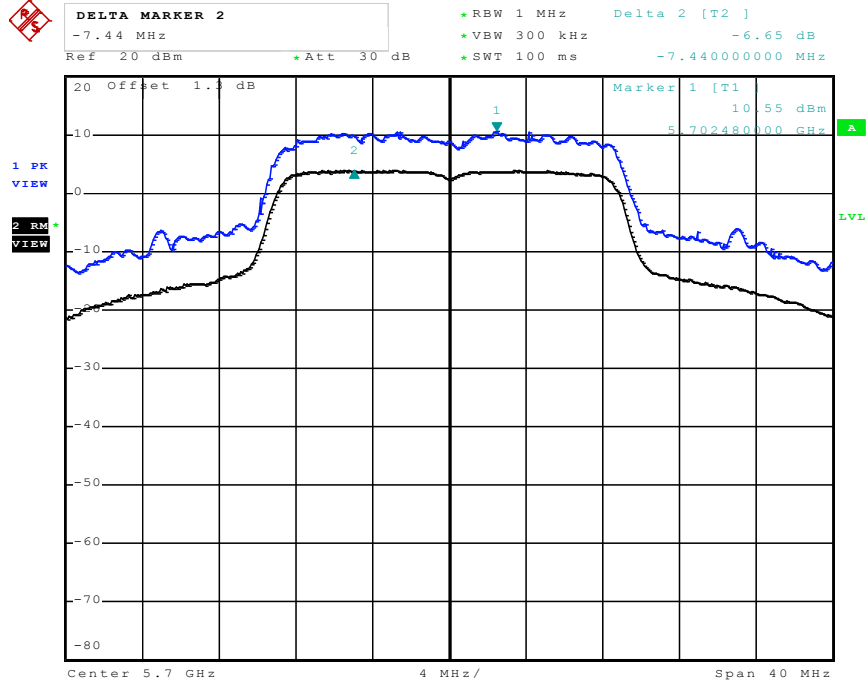

Date: 3.MAY.2011 21:50:29

Peak Excursion Plot on Configuration IEEE 802.11n Ant. A (40MHz) / 5190 MHz

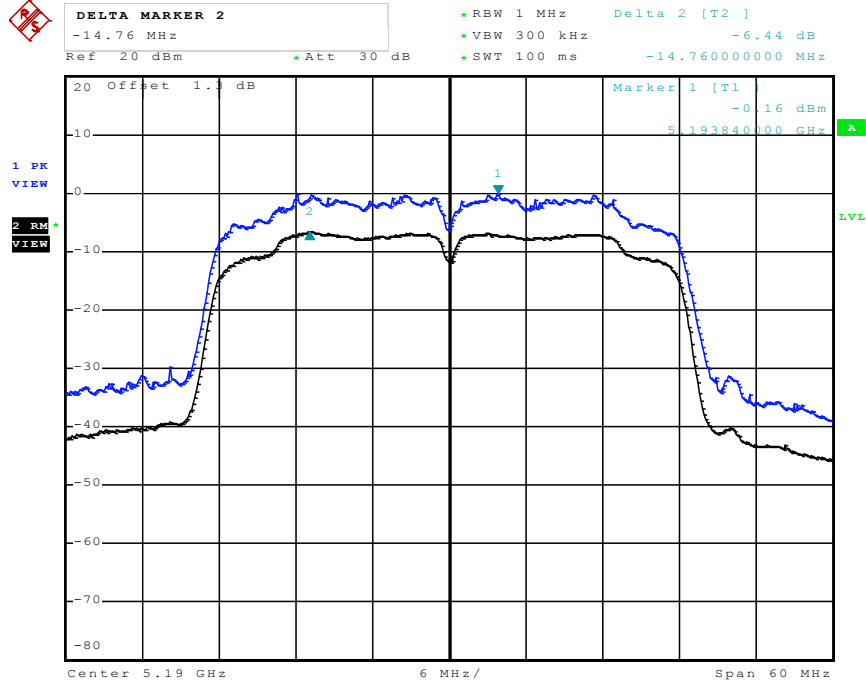

Date: 23.MAY.2011 14:51:28

Peak Excursion Plot on Configuration IEEE 802.11n Ant. A (40MHz) / 5230 MHz

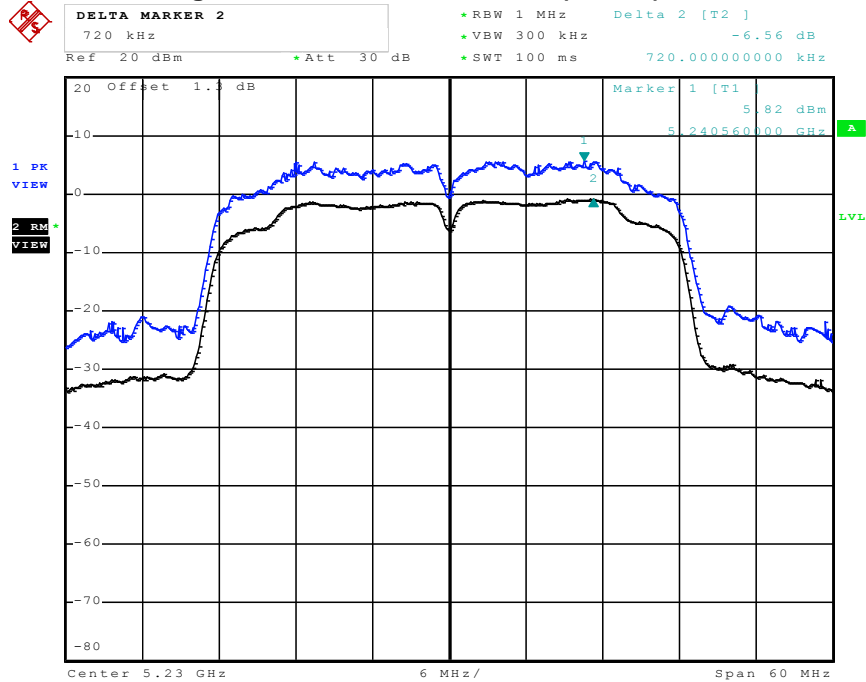

Date: 4.MAY.2011 09:01:13

Peak Excursion Plot on Configuration IEEE 802.11n Ant. A (40MHz) / 5270 MHz

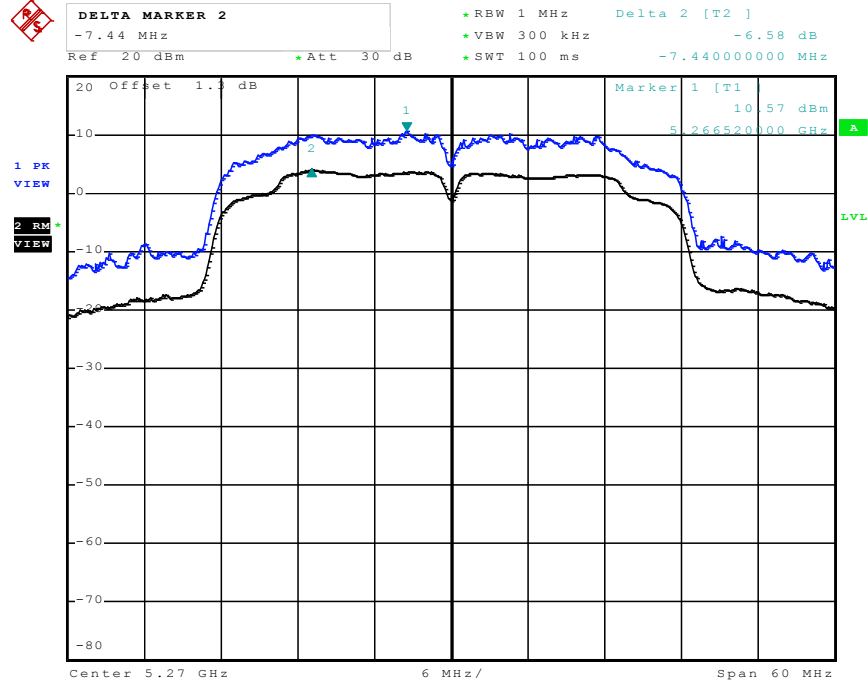

Date: 4.MAY.2011 09:04:33

Peak Excursion Plot on Configuration IEEE 802.11n Ant. A (40MHz) / 5310 MHz

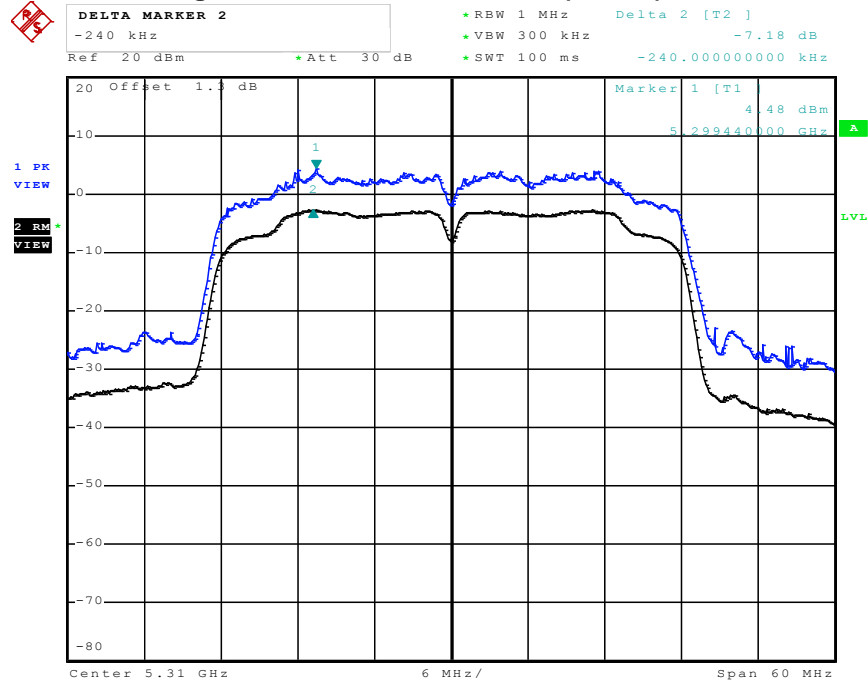

Date: 23.MAY.2011 15:18:23

Peak Excursion Plot on Configuration IEEE 802.11n Ant. A (40MHz) / 5510 MHz

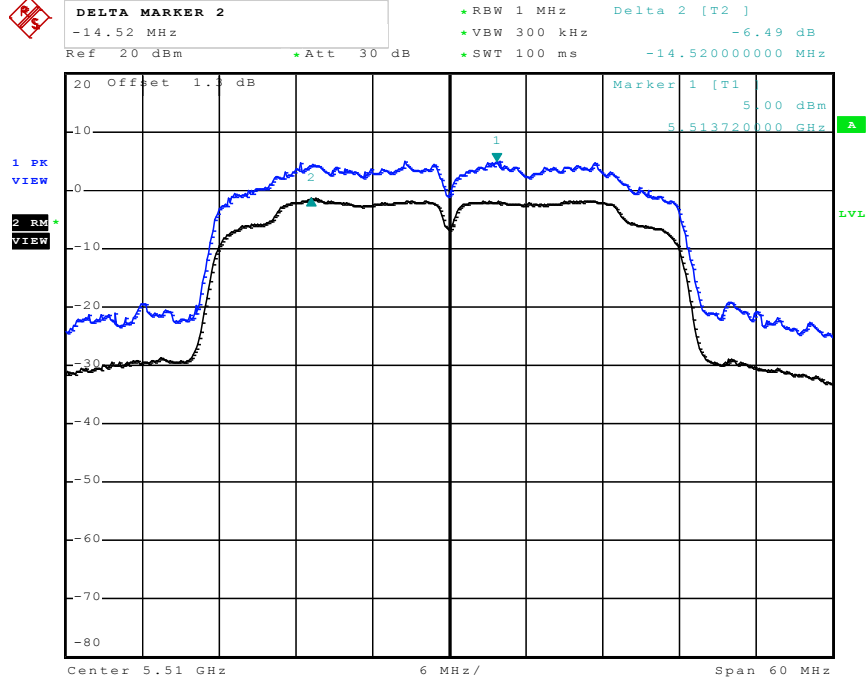

Date: 23.MAY.2011 15:24:18

Peak Excursion Plot on Configuration IEEE 802.11n Ant. A (40MHz) / 5550 MHz

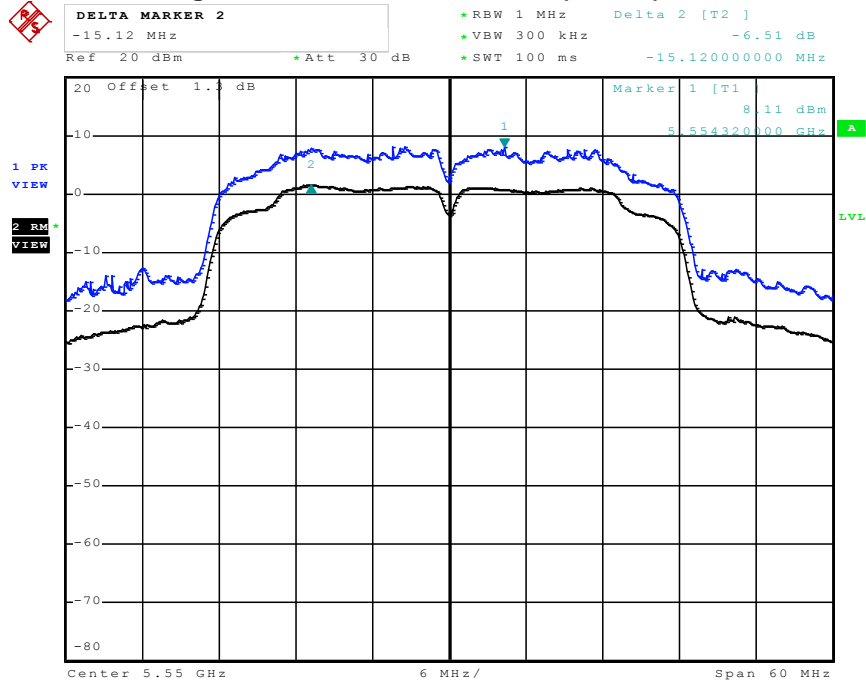

Date: 4.MAY.2011 09:12:36