



COBAN DSSS 900MHz Wireless Microphone System for Law Enforcement

Owner's Manual

COBAN Technologies, Inc.
11375 West Sam Houston Parkway South
Suite # 800
Houston, TX 77031
WWW.CobanTech.COM

COBAN Wireless Microphone System Features

Frequency: 902 to 925 MHz ; DSSS; Frequency Hopping

Range: 1000 ft (Line-of-Sight)

Receiver Module:

Dual Receivers with Dual Separated Independent Antennas

RS-485 communicating to the Host

12 VDC/500mA

Transmitter:

1650 mAh/3.7V Rechargeable Li-Ion Battery (Transmitter)

10 Hours Talk Time

Built-in microphone with optional Lavalier external
Microphone

Optional External Antenna for Extended Distance

One On-Air Button with Two Programmable Buttons

Weatherproof

***THIS DEVICE COMPLIES WITH PART 15 OF THE FCC RULES.
OPERATION IS SUBJECT TO THE CONDITION THAT THIS DEVICE
DOES NOT CAUSE HARMFUL INTERFERENCE.***

COBAN Wireless Microphone System Overview

Wireless Microphone Transmitter



Transmitter Side View

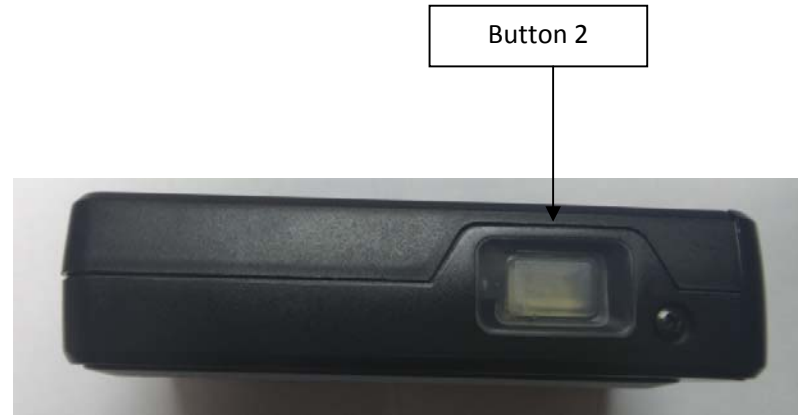

Transmitter Top View

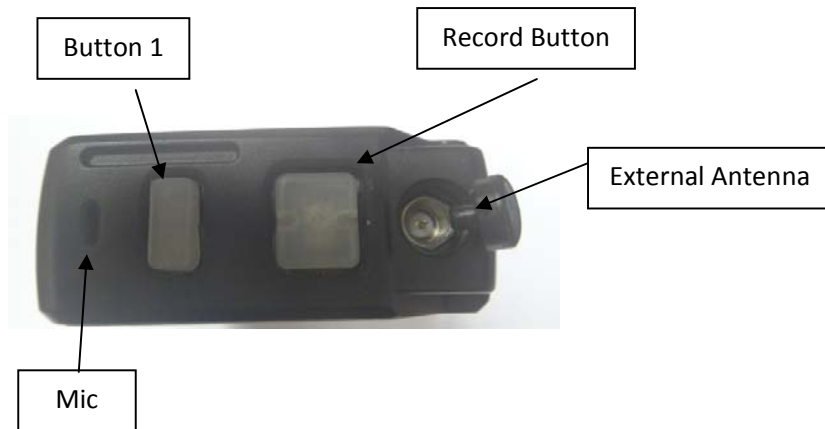

Trasmitter Bottom View



Wireless Microphone Receiver



Sync Contact 2



Sync Contact 1

COBAN Wireless Microphone System Operations



1. Locate the contacts at the bottom of the wireless mic.
2. Press the wireless microphone contacts directly on top of the receiver's register contacts.

NOTE: The receiver is located behind each of the front seats near nearest the door pillar.

3. A confirmation tone will sound to indicate the receiver and the microphone have synchronized their frequencies.
4. The wireless microphone is now on standby mode and ready for use.

NOTE: Syncing a second microphone to the same receiver will replace and nullify the first microphone.

Patrol Car Installation Diagram

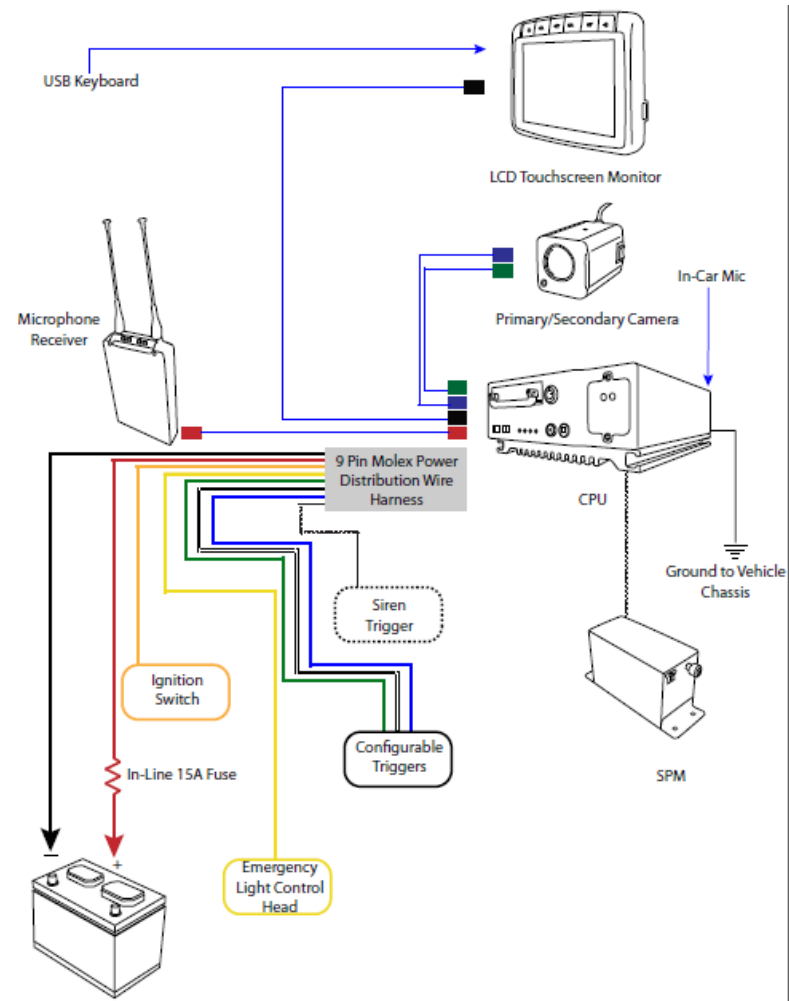

Record button

COBAN Technologies

The large button on the Microphone will always be used to initiate Recording (Default: Front only)

Status Indicators

Programmable Button Functions

1. Mute – Toggle Audio Mute (does not affect Video)
2. Stop – Stop Video (Not Recommended)
3. Marker – Adds a bookmark to the video
4. AutoZoom – Performs AutoZoom on front camera
5. Partner Alert – Notifies other Microphone of emergency (double microphone units only)
6. Covert interview – Starts Rear Seat recording and black-out monitor

Toggle Covert Mode (Vibrate only)

1. Press the Record Button and center Program Button simultaneously for 2 seconds.

Repeat action to enable LED and buzzer (normal) mode.

Toggle between Regular and Covert modes - hold down REC and Button 1 for two seconds	Vibrates and beeps once when active	Vibrates twice when active
Record	Beeps and vibrates Twice GREEN LED (w/o lapel mic) BLUE LED (w/ lapel mic)	Vibrates twice
Low Signal / Out of Range	YELLOW LED Beeps intermittently	Vibrates intermittently
Stop recording – press Button 1 or Button 2	Long beep and vibrate once	Long vibrate once
Mute - press Button 1 or Button 2	GREEN LED BLINKS Beeps and vibrates in interval	Button 2 – vibrate once Button 3 – vibrate twice Continues to vibrate once in interval time frames
Other Programmable functions- press Button 1 or Button 2	Button 2 – beep once Button 3 – beep twice	Button 2 – vibrate once Button 3 – vibrate twice
Panic - hold down REC Button for 3 seconds.	RED LED On - beeps and vibrates 3 times Off - beeps and vibrates once	On - vibrates 3 times Off - vibrates once

Action/Alert	Regular mode (Audio, LED & Vibrate)	Covert mode (Vibrate Only)
--------------	--	-------------------------------

Federal Communication Commission Interference Statement

This equipment has been tested and found to comply with the limits for a Class B digital device, pursuant to Part 15 of the FCC Rules. These limits are designed to provide reasonable protection against harmful interference in a residential installation.

This equipment generates, uses and can radiate radio frequency energy and, if not installed and used in accordance with the instructions, may cause harmful interference to radio communications. However, there is no guarantee that interference will not occur in a particular installation. If this equipment does cause harmful interference to radio or television reception, which can be determined by turning the equipment off and on, the user is encouraged to try to correct the interference by one of the following measures:

- . Reorient or relocate the receiving antenna.
- . Increase the separation between the equipment and receiver.
- . Connect the equipment into an outlet on a circuit different from that to which the receiver is connected.
- . Consult the dealer or an experienced radio/TV technician for help.

FCC Caution: To assure continued compliance, any changes or modifications not expressly approved by the party responsible for compliance could void the user's authority to operate this equipment. (Example - use only shielded interface cables when connecting to computer or peripheral devices).

FCC Radiation Exposure Statement

This equipment complies with FCC RF radiation exposure limits set forth for an uncontrolled environment.

This equipment should be installed and operated with a minimum distance of 20 centimeters between the radiator and your body.

This transmitter must not be co-located or operating in conjunction with any other antenna or transmitter.

The antennas used for this transmitter must be installed to provide a separation distance of at least 20 cm from all persons and must not be co-located or operating in conjunction with any other antenna or transmitter.

This device complies with Part 15 of the FCC Rules. Operation is subject to the following two conditions:

(1) This device may not cause harmful interference, and (2) This device must accept any interference received, including interference that may cause undesired operation.