

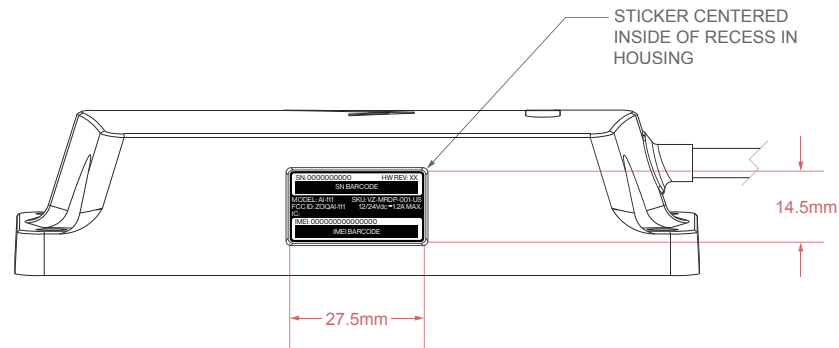

FINISH: MATTE
COLOR: PANTONE BLACK 3C; WHITE
BARCODE FONT: BARCODE 128

NOTE:
PRODUCT INFORMATION STICKER TO BE PERMANENTLY BONDED TO HOUSING. MUST BE ABLE TO WITHSTAND ALL REQUIRED ENVIRONMENTAL FACTORS AND MAINTAIN LEGIBILITY THROUGHOUT LIFESPAN OF PRODUCT.



PRIME
ARTWORK PLACEMENT
SCALE 1:1

| |
|------------------------------------------------|
| PROJECT: VERIZON MERIDIAN ASSET TRACKER |
| DOCUMENT: ARTWORK PACKAGE |
| PART #: 325-500089-001 |
| PAGE: PRIME DEVICE LABEL |
| DATE: DECEMBER 7, 2020 |

Confidential and proprietary materials for authorized Verizon personnel and outside agencies only. Use, disclosure or distribution of this material is not permitted to any unauthorized persons or third parties except by written agreement.

NOTE:
PRODUCT INFORMATION TO BE LASER ETCHED
INTO OUTSIDE SURFACE OF BOTTOM PANEL.

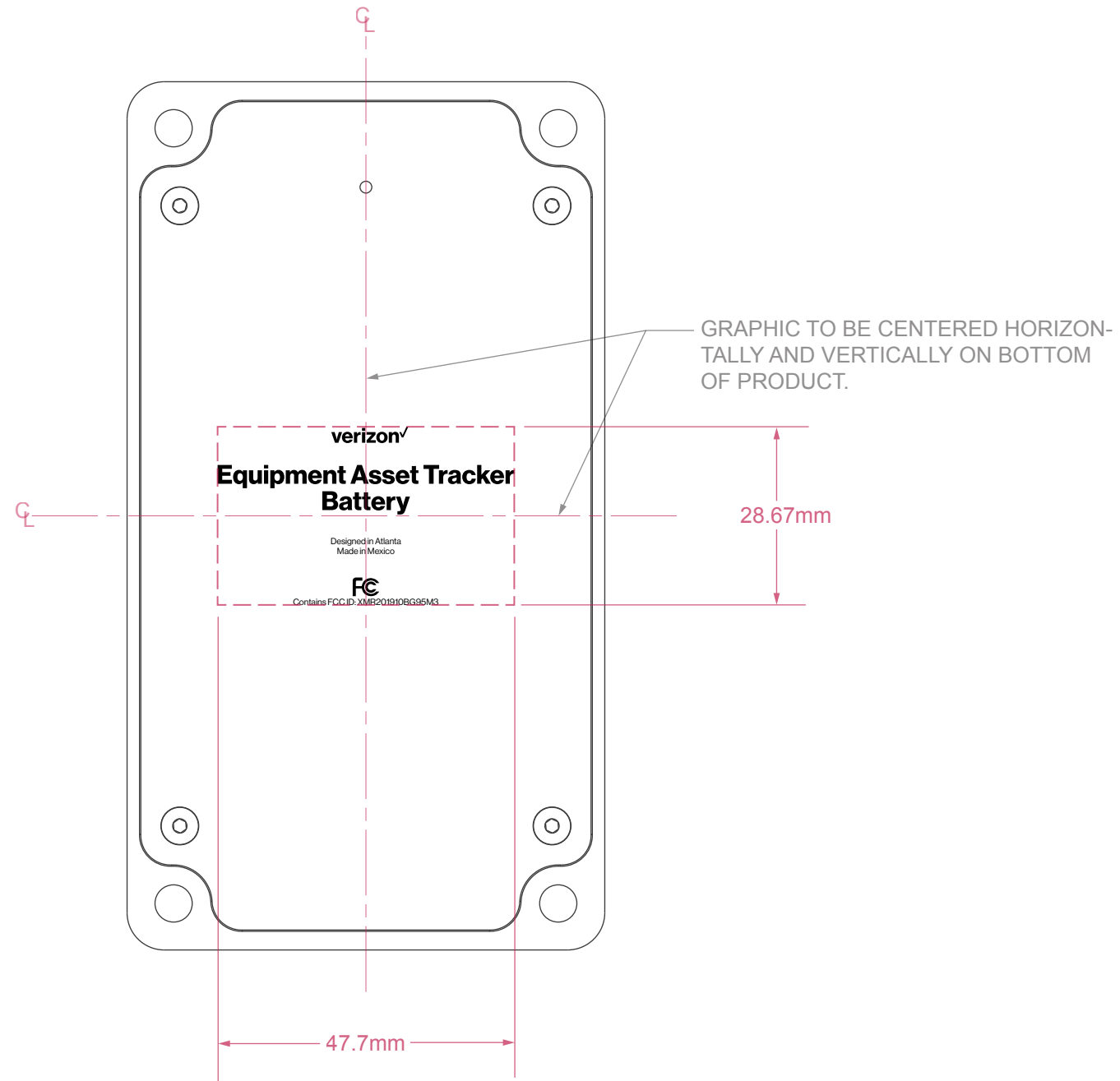

ZENITH
ARTWORK PLACEMENT
SCALE 1:1

| |
|---------------------------------------------------------------------------------------------------------------------------------------------------------------------------------------------------------------------------------------------------------------|
| PROJECT: VERIZON MERIDIAN ASSET TRACKER |
| DOCUMENT: ARTWORK PACKAGE |
| PART #: 920-500162-001 |
| PAGE: ZENITH DEVICE INFORMATION |
| DATE: FEBRUARY 9, 2021 |
| <small>Confidential and proprietary materials for authorized Verizon personnel and outside agencies only. Use, disclosure or distribution of this material is not permitted to any unauthorized persons or third parties except by written agreement.</small> |