

# EMI TEST REPORT

## FCC CERTIFICATION

**Applicant:**

**LG Electronics USA, Inc.**  
**1000 Sylvan Avenue, Englewood Cliffs NJ 07632**  
**United States**

**Date of Issue: April 19, 2019**

**Test Report No. HCT-EM-1904-FC018**

**Test Site: HCT CO., LTD.**

**FCC ID :**

**ZNFX420MM**

Rule Part(s) / Standard(s) : 47 CFR PART 15 Subpart B Class B  
ANSI C63.4-2014

EUT Type : Portable Handset

Model Name : LM-X420MM

Additional Model Name : LMX420MM, X420MM

Date of Test : April 12, 2019 to April 18, 2019

The device bearing the trade name and model specified above, has been shown to comply with the applicable technical standards as indicated in the measurement report and was tested in accordance with the measurement procedures specified in ANSI C63.4-2014. (See Test Report if any modifications were made for compliance)

I attest to the accuracy of data. All measurements reported herein were performed by me or were made under my supervision and are correct to the best of my knowledge and belief. I assume full responsibility for the completeness of these measurements and vouch for the qualifications of all persons taking them.

HCT certifies that no party to application has been denied the FCC benefits pursuant to Section 5301 of the Anti-Drug Abuse Act of 1988, 21 U.S.C 862

***Tested By***



**Na-Eun Song**  
**Test Engineer**  
**EMC Team**  
**Certification Division**

***Reviewed***



**Gu-Cheol Yoon**  
**Technical Manager**  
**EMC Team**  
**Certification Division**

This report only responds to the tested sample and may not be reproduced, except in full, without written approval of the HCT Co., Ltd.



## REVISION HISTORY

*The revision history for this document is shown in table.*

Report No.	Issue Date	Information About Changes
HCT-EM-1904-FC018	April 19, 2019	Initial Release



## TABLE OF CONTENTS

	<b>PAGE</b>
1. GENERAL INFORMATION .....	4
1.1 Description of EUT .....	4
1.2 Tested System Details .....	5
1.3 Cable Description .....	6
1.4 Noise Suppression Parts on Cable. (I/O Cable) .....	6
1.5 Test Facility .....	7
1.6 Calibration of Measuring Instrument .....	7
1.7 Measurement Uncertainty .....	7
2. LIST OF TEST EQUIPMENT .....	8
3. DESCRIPTION OF TEST .....	9
3.1 Measurement of Conducted Emission .....	9
3.2 Measurement of Radiated Emission .....	10
4. OPERATING MODES .....	12
4.1 Conducted Emission .....	12
4.2 Radiated Emission .....	12
5. CONDUCTED AND RADIATED EMISSION TEST SUMMARY .....	13
5.1 Conducted Emission .....	13
5.2 Radiated Emission .....	20
6. CONCLUSION .....	22
7. APPENDIX A. TEST SETUP PHOTOGRAPHS .....	23



## 1. GENERAL INFORMATION

### 1.1 Description of EUT

Its basic purpose is used for communications.

FCC ID	ZNFX420MM
Model	LM-X420MM
Additional Model	LMX420MM, X420MM
EUT Type	Portable Handset
TX Frequency	824.2 MHz to 848.8 MHz (GSM 850) 1 850.2 MHz to 1 909.8 MHz (GSM 1 900) 1 852.4 MHz to 1 907.6 MHz (WCDMA B2) 1712.4 MHz to 1752.6 MHz (WCDMA B4) 826.4 MHz to 846.6 MHz (WCDMA B5) 1 850 MHz to 1 910 MHz (LTE B2) 1 710 MHz to 1 755 MHz (LTE B4) 824 MHz to 849 MHz (LTE B5) 2 496 MHz to 2 570 MHz (LTE B7) 699 MHz to 716 MHz (LTE B12) 1 850 MHz to 1 915 MHz (LTE B25) 814 MHz to 849 MHz (LTE B26) 2 496 MHz to 2 690 MHz (LTE B41) 1 710 MHz to 1 780 MHz (LTE B66) 663 MHz to 698 MHz (LTE B71) 2 402 MHz to 2 480 MHz (Bluetooth) 2 412 MHz to 2 462 MHz (WiFi 2.4 GHz) 5 180 MHz to 5 240 MHz (WiFi 5 GHz_UNII 1) 5 260 MHz to 5 320 MHz (WiFi 5 GHz_UNII 2A) 5 500 MHz to 5 720 MHz (WiFi 5 GHz_UNII 2C) 5 745 MHz to 5 825 MHz (WiFi 5 GHz_UNII 3)
RX Frequency	869.2 MHz to 893.8 MHz (GSM 850) 1 930.2 MHz to 1 989.8 MHz (GSM 1 900) 1 932.4 MHz to 1 987.6 MHz (WCDMA B2) 2 112.4 MHz to 2 152.6 MHz (WCDMA B4) 871.4 MHz to 891.6 MHz (WCDMA B5) 1 930 MHz to 1 990 MHz (LTE B2) 2 110 MHz to 2 155 MHz (LTE B4) 869 MHz to 894 MHz (LTE B5) 2 516 MHz to 2 690 MHz (LTE B7) 729 MHz to 746 MHz (LTE B12) 1 925 MHz to 1 990 MHz (LTE B25) 859 MHz to 894 MHz (LTE B26) 2 496 MHz to 2 690 MHz (LTE B41) 2 110 MHz to 2 200 MHz (LTE B66) 617 MHz to 652 MHz (LTE B71) 2 402 MHz to 2 480 MHz (Bluetooth) 2 412 MHz to 2 462 MHz (WiFi 2.4 GHz) 5 180 MHz to 5 240 MHz (WiFi 5 GHz_UNII 1) 5 260 MHz to 5 320 MHz (WiFi 5 GHz_UNII 2A) 5 500 MHz to 5 720 MHz (WiFi 5 GHz_UNII 2C) 5 745 MHz to 5 825 MHz (WiFi 5 GHz_UNII 3)



## 1.2 Tested System Details

All equipment descriptions used in the tested system (including inserted cards) are:

Device Type	Model Name	Serial Number	Manufacturer
EUT	LM-X420MM	-	LG
Notebook PC	ProBook6560b	5CB2053MXF	HP
Notebook PC Adaptor	Series PPP009L-E	-	LITE-ON TECHNOLOGY
Gateway	TL-WR747N	-	TP Link
Gateway Adaptor	T090060-2H1	-	TP Link
Serial Mouse	Serial 2 Button mouse	02031069	Radio Shack
RJ45 cable	-	-	-
Data Cable *	EAD63769721	-	Ningbo Broad
Data Cable *	EAD63769722	-	CRESYN
Data Cable *	EAD63769723	-	KSD
Earphone *	EAB64468444	-	CRESYN
Micro SD Card	SAMSUNG EVO+ microSDXC CLASS10 UHS-I (256 GB)	-	SAMSUNG

\*NOTE. The worst-case emissions are reported.



### 1.3 Cable Description

Product Name	Port	Power Cord Shielded (Y/N)	I/O Cable Shielded (Y/N)	Length (m)
EUT	Micro USB	Y	Y	(P,D)1.0
	Earphone	N/A	N	(D)1.2
Notebook PC	RJ 45	N/A	N	(D)1.6
	Serial (Mouse)	N/A	Y	(D)1.8
	DC in	N	N/A	(P)1.8
Gateway	DC in	N	N/A	(P)1.8

\* The marked “(D)” means the data cable and “(P)” means the power cable.

### 1.4 Noise Suppression Parts on Cable. (I/O Cable)

Product Name	Port	Ferrite Bead (Y/N)	Location	Metal Hood (Y/N)	Location
EUT	Micro USB	N	N/A	Y	Both End
	Earphone	N	N/A	Y	EUT End
Notebook PC	RJ 45	N	N/A	N	N/A
	Serial (Mouse)	N	N/A	Y	Notebook PC End



## 1.5 Test Facility

Test site is located at 74, SEOICHEON-RO, 578BEON-GIL, MAJANG-MYEON, ICHEON-SI, GYEONGGI-DO, SOUTH KOREA. Those measurement facilities are constructed in conformance with the requirements of ANSI C63.4-2014. The Normalized site attenuations (30 MHz to 1 GHz) and Site validation (1 GHz to 18 GHz) were performed in accordance with the standard in ANSI C63.4-2014

Measurement Facilities	Registration Number
Radiated Field strength measurement facility 3 m Semi Anechoic chamber	90661
Radiated Field strength measurement facility 10 m Semi Anechoic chamber	

## 1.6 Calibration of Measuring Instrument

The measuring equipment, which was utilized in performing the tests documented herein, has been calibrated in accordance with the manufacturers recommendations for utilizing calibration equipments, which is traceable to recognized national standards.

Especially, all antenna for measurement is calibrated in accordance with the requirements of C63.5 (Version : 2006).

## 1.7 Measurement Uncertainty

The measurement uncertainties shown below were calculated in accordance with the requirements of ANSI C63.4-2014.

All measurement uncertainty values are shown with a coverage factor of  $k = 2$  to indicate a 95 % level of confidence. The measurement data shown herein meets or exceeds the  $U_{\text{CISPR}}$  measurement uncertainty values specified in CISPR 16-4-2 and, thus, can be compared directly to specified limits to determine compliance.

Parameter	Expanded Uncertainty (dB)
Conducted Emission (0.15 MHz to 30 MHz)	1.82 dB
Radiated Emissions (30 MHz to 1 GHz)	5.20 dB
Radiated Emissions (1 GHz to 18 GHz)	5.24 dB
Radiated Emissions (18 GHz to 40 GHz)	5.40 dB



## 2. LIST OF TEST EQUIPMENT

<u>Type</u>	<u>Manufacturer</u>	<u>Model Name</u>	<u>Serial Number</u>	<u>Calibration Cycle</u>	<u>CAL Date</u>
<u>Conducted Emission</u>					
<input checked="" type="checkbox"/> EMI Test Receiver	Rohde & Schwarz	ESCI	100584	1 year	06.25.2018
<input type="checkbox"/> EMI Test Receiver	Rohde & Schwarz	ESCI	100033	1 year	06.27.2018
<input checked="" type="checkbox"/> LISN	Rohde & Schwarz	ENV216	102245	1 year	12.12.2018
<input checked="" type="checkbox"/> LISN	Rohde & Schwarz	ENV216	100073	1 year	05.03.2018
<input checked="" type="checkbox"/> Software	Rohde & Schwarz	EMC32 VER8.54.0	-	-	-
<u>Radiated Emission</u>					
-For measurement below 1 GHz					
<input checked="" type="checkbox"/> EMI Test Receiver	Rohde & Schwarz	ESU40	100524	1 year	07.27.2018
<input checked="" type="checkbox"/> Trilog Antenna	Schwarzbeck	VULB 9168	760	2 year	03.22.2019
<input checked="" type="checkbox"/> Antenna master	INNCO Systems	MA4640-XP-ET	-	N/A	-
<input checked="" type="checkbox"/> Antenna master controller	INNCO Systems	CO 3000	CO3000/870/ 35990515/L	N/A	-
<input checked="" type="checkbox"/> Turn Table	INNCO Systems	1060	-	N/A	-
<input checked="" type="checkbox"/> Turn Table controller	INNCO Systems	CO2000	CO2000/095/ 7590304/L	N/A	-
<input type="checkbox"/> EMI Test Receiver	Rohde & Schwarz	ESU26	100241	1 year	08.14.2018
<input type="checkbox"/> Antenna master	INNCO Systems	MA4000-EP	MA4000/283	N/A	-
<input type="checkbox"/> Turn Table	INNCO Systems	DT3000-3T	DT3000/69	N/A	-
<input checked="" type="checkbox"/> Software	Rohde & Schwarz	EMC32 VER8.40.0	-	-	-
-For measurement above 1 GHz					
<input checked="" type="checkbox"/> EMI Test Receiver	Rohde & Schwarz	ESU40	100524	1 year	07.27.2018
<input checked="" type="checkbox"/> Antenna master	INNCO Systems	MA4640-XP-ET	-	N/A	-
<input checked="" type="checkbox"/> Antenna master controller	INNCO Systems	CO3000	CO3000/870/ 35990515/L	N/A	-
<input checked="" type="checkbox"/> Turn Table	INNCO Systems	1060	-	N/A	-
<input checked="" type="checkbox"/> Turn Table controller	INNCO Systems	CO2000	CO2000/095/ 7590304/L	N/A	-
<input checked="" type="checkbox"/> Low Noise Amplifier	TESTEK	TK-PA18H	170034-L	1 year	03.04.2019
<input checked="" type="checkbox"/> Power Amplifier	TESTEK	TK-PA1840H	170030-L	1 year	12.17.2018
<input checked="" type="checkbox"/> Horn Antenna	Schwarzbeck	BBHA 9120D	01836	2 year	07.20.2018
<input checked="" type="checkbox"/> Horn Antenna	Schwarzbeck	BBHA 9170	BBHA9170#786	2 year	12.05.2017
<input type="checkbox"/> Antenna master controller	HD GmbH	HD 100	100/637	N/A	-
<input type="checkbox"/> Power Amplifier	CERNEX	CBLU1183540	21691	1 year	06.25.2018
<input type="checkbox"/> Antenna master	HD GmbH	MA240	240/520	N/A	-
<input type="checkbox"/> EMI Test Receiver	Rohde & Schwarz	ESU26	100241	1 year	08.14.2018
<input type="checkbox"/> Turn Table	INNCO Systems	DT3000-3T	DT3000/69	N/A	-
<input checked="" type="checkbox"/> Software	Rohde & Schwarz	EMC32 VER8.40.0	-	-	-





### 3. DESCRIPTION OF TEST

#### 3.1 Measurement of Conducted Emission

The test procedure was in accordance with ANSI C63.4-2014, Clause 7.3

- a. The EUT was placed 0.4 meters from the conducting wall of the shielded room with EUT being connected to the power mains through a line impedance stabilization network (LISN).  
If the EUT is connected to the PC through USB, the AC power-line adapter of the PC is directly connected to a line impedance stabilization network (LISN).  
Other support units were connected to the power mains through another LISN. The two LISNs provide 50 Ohm/ 50uH of coupling impedance for the measuring instrument.
- b. Both conducted lines are measured in Quasi-Peak and Average mode, including the worst-case data points for each tested configuration.
- c. The frequency range from 150 kHz to 30 MHz was searched.

#### [ Conducted Emission Limits ]

Frequency (MHz)	Resolution Bandwidth (kHz)	Quasi-Peak (dB(μV))	Average (dB(μV))
0.15 to 0.5	9	66 to 56*	56 to 46*
0.5 to 5	9	56	46
5 to 30	9	60	50

*\*Decreases with the logarithm of the frequency.*



### 3.2 Measurement of Radiated Emission

The test procedure was in accordance with ANSI C63.4-2014, Clause 8.3

- a. The EUT was placed on the top of a turn table 0.8 meters above the ground at a semi-anechoic chamber. The table was rotated 360 degrees to determine the position of the highest radiation.
- b. The EUT was set 3 m away from the interference-receiving antenna, which was mounted on the top of a variable-height antenna tower.
- c. The antenna height is varied from 1 m to 4 m above the ground to determine the maximum value of the field strength. Both horizontal and vertical polarizations of the antenna are set to make the measurement.
- d. For each suspected emission, the EUT was arranged to its worst case and then the antenna was tuned to heights from 1 m to 4 m and the turn table was turned from 0 degrees to 360 degrees to find the maximum reading.
- e. The test-receiver system was set to Quasi-Peak detect function and specified bandwidth with maximum hold mode when the test frequency is below 1 GHz.
- f. The test-receiver system was set to Peak and Average detect function and specified bandwidth with maximum hold mode when the test frequency is above 1 GHz.
- g. Place the measurement antenna away from each area of the EUT determined to be a source of emissions at the specified measurement distance, while keeping the measurement antenna aimed at the source of emissions at each frequency of significant emissions, with polarization oriented for maximum response.(1 GHz to 40 GHz)

#### [ Radiated Emission Limits ]

Frequency (MHz)	Antenna Distance (m)	Field Strength ( $\mu\text{V}/\text{m}$ )	Quasi-Peak ( $\text{dB}(\mu\text{V}/\text{m})$ )
30 to 88	3	100	40.0
88 to 216	3	150	43.5
216 to 960	3	200	46.0
Above 960	3	500	54.0
Frequency (MHz)	Antenna Distance (m)	Peak ( $\text{dB}(\mu\text{V}/\text{m})$ )	Average ( $\text{dB}(\mu\text{V}/\text{m})$ )
Above 1 000	3	74	54



### 3.2.1 Frequency Range of Radiated Measurements

An unintentional radiator, including a digital device, the spectrum shall be investigated from the lowest radio frequency signal generated or used in the device, without going below the lowest frequency for which a Radiated Emission limit is specified, up to the frequency shown in the following table

Highest frequency generated or used in the device or on which the device operates or tunes (MHz)	Upper frequency of measurement range (MHz)
Below 1.705	30
1.705 to 108	1 000
108 to 500	2 000
500 to 1 000	5 000
Above 1 000	5 <sup>th</sup> harmonic of the highest frequency or 40 GHz, whichever is lower

### 3.3 Configuration of Tested System

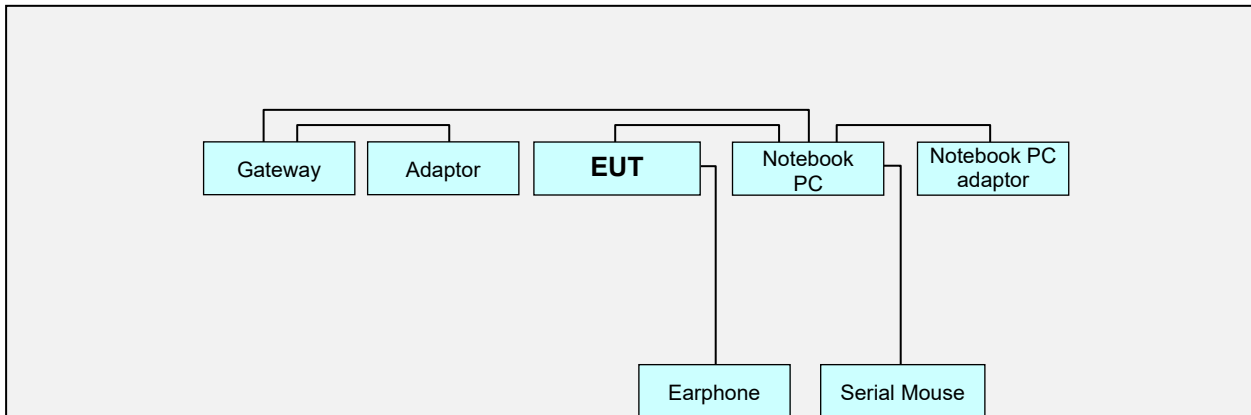

Non-Conductive Table  
 Power Line: 120 VAC, 60 Hz



## 4. PRELIMINARY TEST

### 4.1 Conducted Emission

It was tested the following operating mode, after connecting all peripheral devices.

**Operating Modes:**

Data Communication mode

### 4.2 Radiated Emission

It was tested the following operating mode, after connecting all peripheral devices.

**Operating Modes:**

Data Communication mode



## 5. CONDUCTED AND RADIATED EMISSION TEST SUMMARY

### 5.1 Conducted Emission

The test results of conducted emission at mains ports provide the following information:

Rule Part / Standard	FCC PART 15 Subpart B Class B
Detector	Quasi-Peak, CISPR-Average
Bandwidth	9 kHz (6 dB)
Operating Mode	Data Communication mode
Worst Case of Data Cable	EAD63769722 (CRESYN)
Kind of Test Site	Shielded Room
Temperature	21.5 °C
Relative Humidity	42.6 %
Test Date	April 15, 2019

#### ***- Calculation Formula:***

1. Conductor L1 = Hot, Conductor N = Neutral
2. Corr. = LISN Factor + Cable Loss
3. QuasiPeak or CAverage= Receiver Reading + Corr.
4. Margin = Limit – QuasiPeak or CAverage



Figure 1: Conducted Emission, AC Main Port, Line (L1)

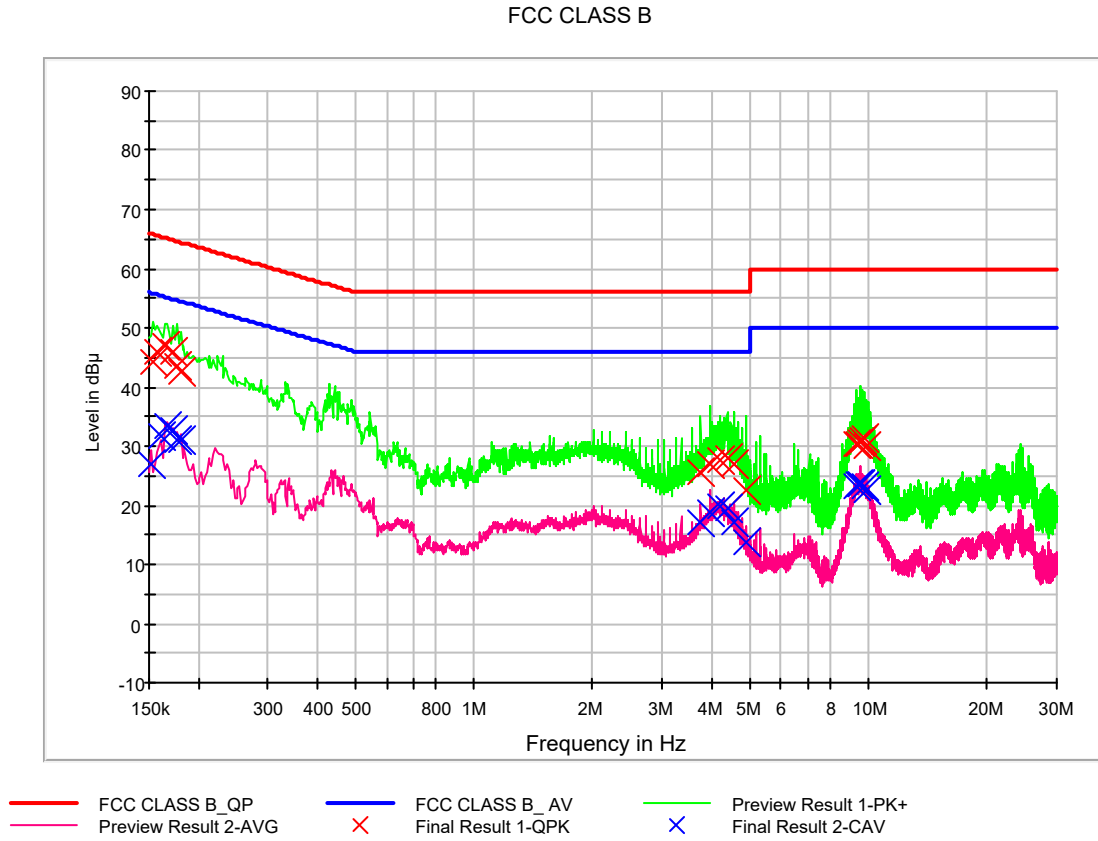



### QuasiPeak Final Result, Line (L1)

Frequency (MHz)	QuasiPeak (dBuV)	Bandwidth (kHz)	Line	Corr. (dB)	Margin (dB)	Limit (dBuV)
0.154000	44.1	9.000	L1	9.6	21.7	65.8
0.158000	45.9	9.000	L1	9.6	19.6	65.6
0.164000	47.0	9.000	L1	9.6	18.3	65.3
0.172000	46.0	9.000	L1	9.6	18.8	64.9
0.176000	43.7	9.000	L1	9.6	21.0	64.7
0.180000	42.4	9.000	L1	9.6	22.1	64.5
3.762000	25.5	9.000	L1	9.8	30.5	56.0
3.968000	26.9	9.000	L1	9.8	29.1	56.0
4.226000	27.6	9.000	L1	9.8	28.4	56.0
4.382000	27.8	9.000	L1	9.8	28.2	56.0
4.588000	27.1	9.000	L1	9.8	28.9	56.0
4.900000	22.7	9.000	L1	9.8	33.3	56.0
9.358000	30.4	9.000	L1	10.0	29.6	60.0
9.462000	30.4	9.000	L1	10.0	29.6	60.0
9.568000	30.8	9.000	L1	10.0	29.2	60.0
9.668000	30.8	9.000	L1	10.0	29.2	60.0
9.774000	31.2	9.000	L1	10.0	28.8	60.0
9.882000	30.1	9.000	L1	10.0	29.9	60.0



## CAverage Final Result, Line (L1)

Frequency (MHz)	CAverage (dBuV)	Bandwidth (kHz)	Line	Corr. (dB)	Margin (dB)	Limit (dBuV)
0.152000	26.8	9.000	L1	9.6	29.1	55.9
0.160000	31.6	9.000	L1	9.6	23.9	55.5
0.166000	33.2	9.000	L1	9.6	21.9	55.2
0.172000	32.7	9.000	L1	9.6	22.1	54.9
0.176000	31.0	9.000	L1	9.6	23.7	54.7
0.180000	30.9	9.000	L1	9.6	23.6	54.5
3.762000	17.3	9.000	L1	9.8	28.7	46.0
3.968000	18.9	9.000	L1	9.8	27.1	46.0
4.226000	19.8	9.000	L1	9.8	26.2	46.0
4.382000	19.5	9.000	L1	9.8	26.5	46.0
4.588000	17.2	9.000	L1	9.8	28.8	46.0
4.900000	13.8	9.000	L1	9.8	32.2	46.0
9.358000	23.3	9.000	L1	10.0	26.7	50.0
9.462000	23.7	9.000	L1	10.0	26.3	50.0
9.566000	23.7	9.000	L1	10.0	26.3	50.0
9.590000	23.7	9.000	L1	10.0	26.3	50.0
9.774000	23.4	9.000	L1	10.0	26.6	50.0
9.882000	22.7	9.000	L1	10.0	27.3	50.0





Figure 2: Conducted Emission, AC Main Port, Line (N)

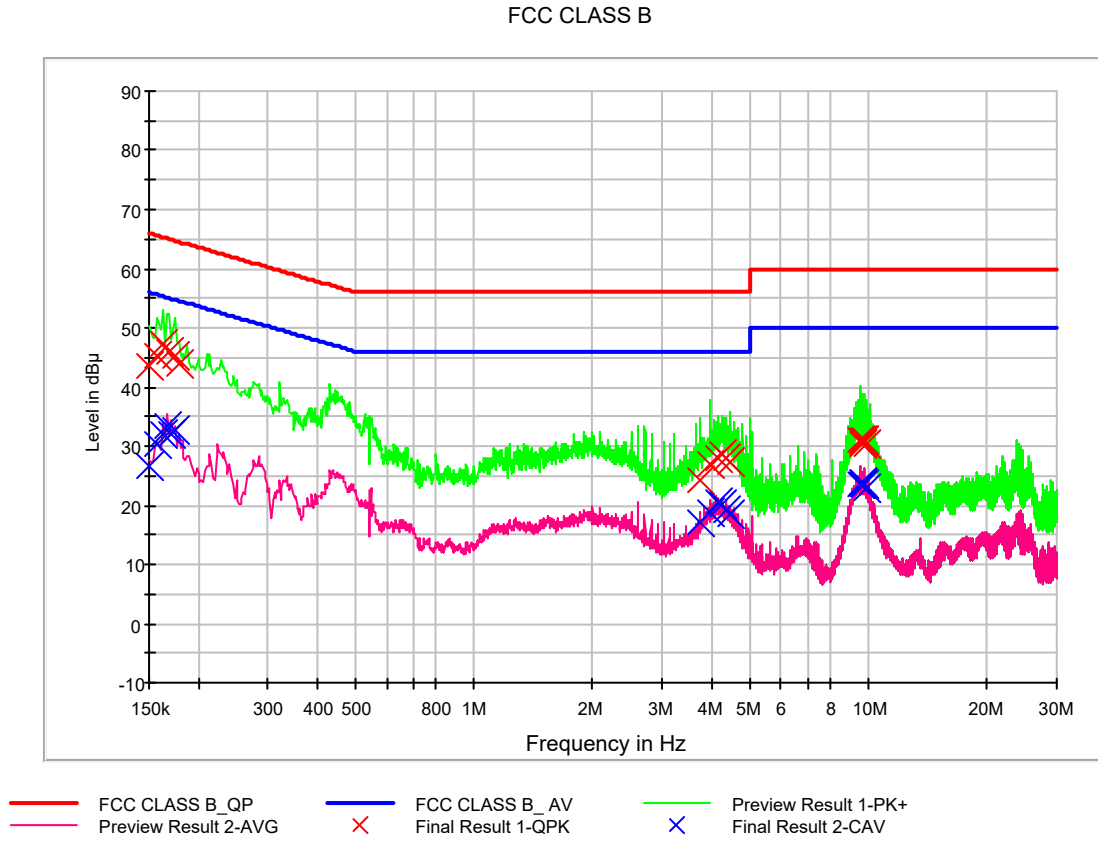



### QuasiPeak Final Result, Line (N)

Frequency (MHz)	QuasiPeak (dBuV)	Bandwidth (kHz)	Line	Corr. (dB)	Margin (dB)	Limit (dBuV)
0.150000	43.5	9.000	N	9.6	22.5	66.0
0.158000	45.4	9.000	N	9.6	20.2	65.6
0.162000	47.1	9.000	N	9.6	18.2	65.4
0.168000	46.1	9.000	N	9.6	19.0	65.1
0.174000	45.3	9.000	N	9.6	19.5	64.8
0.178000	43.9	9.000	N	9.6	20.7	64.6
3.744000	24.1	9.000	N	9.8	31.9	56.0
3.950000	26.9	9.000	N	9.8	29.1	56.0
4.156000	28.1	9.000	N	9.8	27.9	56.0
4.258000	28.6	9.000	N	9.8	27.4	56.0
4.362000	28.0	9.000	N	9.8	28.0	56.0
4.464000	27.2	9.000	N	9.8	28.8	56.0
9.536000	30.9	9.000	N	9.9	29.1	60.0
9.634000	30.4	9.000	N	9.9	29.6	60.0
9.638000	30.8	9.000	N	9.9	29.2	60.0
9.680000	31.2	9.000	N	9.9	28.8	60.0
9.744000	31.1	9.000	N	9.9	28.9	60.0
9.846000	30.3	9.000	N	9.9	29.7	60.0



## CAverage Final Result, Line (N)

Frequency (MHz)	CAverage (dBuV)	Bandwidth (kHz)	Line	Corr. (dB)	Margin (dB)	Limit (dBuV)
0.150000	26.6	9.000	N	9.6	29.4	56.0
0.158000	30.4	9.000	N	9.6	25.1	55.6
0.162000	31.9	9.000	N	9.6	23.5	55.4
0.166000	33.3	9.000	N	9.6	21.9	55.2
0.170000	32.0	9.000	N	9.6	22.9	55.0
0.174000	32.6	9.000	N	9.6	22.2	54.8
3.744000	17.1	9.000	N	9.8	28.9	46.0
3.950000	18.9	9.000	N	9.8	27.1	46.0
4.156000	20.4	9.000	N	9.8	25.6	46.0
4.258000	20.2	9.000	N	9.8	25.8	46.0
4.362000	19.2	9.000	N	9.8	26.8	46.0
4.464000	18.3	9.000	N	9.8	27.7	46.0
9.536000	23.7	9.000	N	9.9	26.3	50.0
9.634000	23.8	9.000	N	9.9	26.2	50.0
9.638000	23.8	9.000	N	9.9	26.2	50.0
9.680000	23.6	9.000	N	9.9	26.4	50.0
9.740000	23.7	9.000	N	9.9	26.3	50.0
9.846000	22.9	9.000	N	9.9	27.1	50.0



## 5.2 Radiated Emission

The test results of radiated emission provide the following information:

### For Measurement Below 1 GHz

Rule Part / Standard	FCC PART 15 Subpart B Class B
Detector	Quasi-Peak
Bandwidth	120 kHz (6 dB)
Operating Mode	Data Communication mode
Worst Case of Data Cable	EAD63769722 (CRESYN)
Kind of Test Site	3 m semi anechoic chamber
Temperature	23.5 °C
Relative Humidity	43.6 %
Test Date	April 16, 2019

Frequency (MHz)	Quasi Peak (dB $\mu$ V/m)	Antenna Height (cm)	POL. (H/V)	Azimuth (deg)	Corr. (dB)	Margin (dB)	Limit (dB $\mu$ V/m)
85.508000	25.3	225.1	H	304.0	14.7	14.7	40.0
133.275200	26.9	100.0	V	296.0	18.8	16.6	43.5
266.524800	34.0	100.0	H	148.0	19.5	12.0	46.0
275.960800	33.4	125.3	H	128.0	19.8	12.6	46.0
600.035200	38.3	100.0	H	0.0	27.6	7.7	46.0
799.984000	38.0	100.0	H	54.0	30.4	8.0	46.0

### - Calculation Formula:

1. POL. H = Horizontal, POL. V = Vertical
2. QuasiPeak = Reading (Receiver Reading) + Corr.
3. Corr. (Correction Factor) = Antenna Factor + Cable Loss
4. Margin = Limit - QuasiPeak



### For Measurement Above 1 GHz

Rule Part / Standard	FCC PART 15 Subpart B Class B
Detector	Peak mode: Peak (RBW: 1 MHz, VBW: 3 MHz) CISPR-Average mode: Peak (RBW: 1 MHz, VBW: 10 Hz)
Highest Frequency	5 825 MHz
Tested Frequency Range	1 GHz to 30 GHz
Operation Mode	Data Communication mode
Worst Case of Data Cable	EAD63769722 (CRESYN)
Kind of Test Site	3 m semi anechoic chamber
Temperature	24.3 °C
Relative Humidity	43.4 %
Test Date	April 18, 2019

Frequency (MHz)	Peak (dB $\mu$ V/m)	Antenna Height (cm)	POL. (H/V)	Azimuth (deg)	Corr. (dB)	Margin (dB)	Limit (dB $\mu$ V/m)
1400.140000	50.6	219.4	V	250.0	-26.1	23.4	74.0
1995.565000	51.5	100.0	V	49.0	-25.3	22.5	74.0
2663.965000	48.5	150.0	V	13.0	-22.7	25.5	74.0
4497.710000	44.5	100.0	V	0.0	-17.6	29.5	74.0
9911.985000	47.9	249.9	H	46.0	-5.4	26.1	74.0
11160.995000	47.5	124.7	H	99.0	-2.6	26.5	74.0

Frequency (MHz)	CAverage (dB $\mu$ V/m)	Antenna Height (cm)	POL. (H/V)	Azimuth (deg)	Corr. (dB)	Margin (dB)	Limit (dB $\mu$ V/m)
1400.140000	40.6	219.4	V	250.0	-26.1	13.4	54.0
1995.565000	27.2	100.0	V	49.0	-25.3	26.8	54.0
2663.965000	23.2	150.0	V	13.0	-22.7	30.8	54.0
4497.710000	27.5	100.0	V	0.0	-17.6	26.5	54.0
9911.985000	35.0	249.9	H	46.0	-5.4	19.0	54.0
11160.995000	35.1	124.7	H	99.0	-2.6	18.9	54.0

#### - Calculation Formula:

1. POL. H = Horizontal, POL. V = Vertical
2. Peak or CAverage = Reading (Receiver Reading) + Corr.
3. Corr. (Correction Factor) = Antenna Factor+ Cable Loss –Amplifier Gain
4. Margin = Limit - Peak or CAverage



## 6. CONCLUSION

The data collected shows that the **EUT Type: Portable Handset, FCC ID: ZNFX420MM, Model: LM-X420MM** complies with §15.107 and §15.109 of the FCC rules.



## 7. APPENDIX A. TEST SETUP PHOTOGRAPHS

Please refer to Annex A.