

# EMI TEST REPORT

## FCC CERTIFICATION

**Applicant:**

LG Electronics MobileComm U.S.A., Inc.  
1000 Sylvan Avenue, Englewood Cliffs NJ 07632  
United States

**Date of Receipt: January 22, 2018****Date of Issue: January 29, 2018****Test Report No. HCT-EM-1801-FC039****FCC ID :****ZNFX410UM****Rule Part(s) / Standard(s):** FCC CFR 47 PART 15 Subpart B Class B**FCC Classification:** JBP (Part 15 B – Class B Computing Device Peripheral)**EUT Type:** Multi-band CDMA/GSM/WCMDA/LTE Phone with BT and WLAN**Model Name:** LM-X410UM**Additional Model Name:** LMX410UM, X410UM, LM-X410ULML, LMX410ULML,  
X410ULML**Date of Test:** January 19, 2018 – January 24, 2018

The device bearing the trade name and model specified above, has been shown to comply with the applicable technical standards as indicated in the measurement report and was tested in accordance with the measurement procedures specified in ANSI C63.4-2014. (See Test Report if any modifications were made for compliance)

I attest to the accuracy of data. All measurements reported herein were performed by me or were made under my supervision and are correct to the best of my knowledge and belief. I assume full responsibility for the completeness of these measurements and vouch for the qualifications of all persons taking them.

HCT certifies that no party to application has been denied the FCC benefits pursuant to Section 5301 of the Anti-Drug Abuse Act of 1988, 21 U.S.C 862

**Tested By**

**Dong-Hwan Seo**  
Test Engineer  
EMC Team  
Certification Division

**Reviewed By**

**Jin-Pyo Hong**  
Technical Manager  
EMC Team  
Certification Division

This report only responds to the tested sample and may not be reproduced, except in full, without written approval of the HCT Co., Ltd.



## REVISION HISTORY

*The revision history for this document is shown in table.*

Report No.	Issue Date	Information About Changes
HCT-EM-1801-FC039	January 29, 2018	Initial Release



## TABLE OF CONTENTS

	<b>PAGE</b>
1. GENERAL INFORMATION .....	4
1.1 Description of EUT .....	4
1.2 Related Submittal(s) / Grant(s) .....	5
1.3 Test Facility .....	5
1.4 Calibration of Measuring Instrument .....	5
1.5 Tested System Details .....	6
1.6 Cable Description .....	7
1.7 Noise Suppression Parts on Cable. (I/O Cable) .....	7
2. MEASUREMENT UNCERTAINTY .....	8
3. DESCRIPTION OF TEST .....	9
3.1 Measurement of Conducted Emission.....	9
3.2 Measurement of Radiated Measurements .....	10
4. PRELIMINARY TEST .....	12
4.1 Conducted Emission Test .....	12
4.2 Radiated Emission Test .....	12
5. CONDUCTED AND RADIATED EMISSION TEST SUMMARY .....	13
5.1 Conducted Emission Test .....	13
5.2 Radiated Emission Test .....	20
6. LIST OF TEST EQUIPMENT.....	22
7. CONCLUSION.....	23
8. APPENDIX A_ TEST SETUP PHOTOGRAPHS .....	24



## 1. GENERAL INFORMATION

### 1.1 Description of EUT

Its basic purpose is used for communications.

FCC ID	ZNFX410UM
Model	LM-X410UM
Additional Model	LMX410UM, X410UM, LM-X410ULML, LMX410ULML, X410ULML
EUT Type	Multi-band CDMA/GSM/WCDMA/LTE Phone with BT and WLAN
TX Frequency	824 MHz to 849 MHz (CDMA BC0) 1 850 MHz to 1 910 MHz (CDMA BC1) 824.20 MHz to 848.80 MHz (GSM 850) 1 850.20 MHz to 1 909.80 MHz (GSM 1 900) 826.40 MHz to 846.60 MHz (WCDMA 850) 1 852.4 MHz to 1 907.6 MHz (WCDMA 1 900) 1 850.7 MHz to 1 909.3 MHz (LTE B2) 1 710 MHz to 1 755 MHz (LTE B4) 824 MHz to 849 MHz (LTE B5) 777 MHz to 787 MHz (LTE B13) 2 402 MHz to 2 480 MHz (Bluetooth) 2 412 MHz to 2 462 MHz (WiFi 2.4 GHz) 5 180 MHz to 5 240 MHz (WiFi 5 GHz_UNII 1) 5 260 MHz to 5 320 MHz (WiFi 5 GHz_UNII 2A) 5 500 MHz to 5 720 MHz (WiFi 5 GHz_UNII 2C) 5 745 MHz to 5 825 MHz (WiFi 5 GHz_UNII 3)
RX Frequency	869 MHz to 894 MHz (CDMA BC0) 1 930 MHz to 1 990 MHz (CDMA BC1) 869.20 MHz to 893.80 MHz (GSM 850) 1 930.20 MHz to 1 989.80 MHz (GSM 1 900) 871.40 MHz to 891.60 MHz (WCDMA 850) 1 932.4 MHz to 1 987.6 MHz (WCDMA 1 900) 1 930 MHz to 1 990 MHz (LTE B2) 2 110 MHz to 2 155 MHz (LTE B4) 869 MHz to 894 MHz (LTE B5) 746 MHz to 756 MHz (LTE B13) 2 402 MHz to 2 480 MHz (Bluetooth) 2 412 MHz to 2 462 MHz (WiFi 2.4 GHz) 5 180 MHz to 5 240 MHz (WiFi 5 GHz_UNII 1) 5 260 MHz to 5 320 MHz (WiFi 5 GHz_UNII 2A) 5 500 MHz to 5 720 MHz (WiFi 5 GHz_UNII 2C) 5 745 MHz to 5 825 MHz (WiFi 5 GHz_UNII 3)



## 1.2 Related Submittal(s) / Grant(s)

Original submittal only.

## 1.3 Test Facility

Test site is located at 74, SEOICHEON-RO, 578BEON-GIL, MAJANG-MYEON, ICHEON-SI, GYEONGGI-DO, SOUTH KOREA. Those measurement facilities are constructed in conformance with the requirements of ANSI C63.4-2014.

Measurement Facilities	Registration Number
Radiated Field strength measurement facility 3 m Semi Anechoic chamber	90661
Radiated Field strength measurement facility 10 m Semi Anechoic chamber	

## 1.4 Calibration of Measuring Instrument

The measuring equipment, which was utilized in performing the tests documented herein, has been calibrated in accordance with the manufacturers recommendations for utilizing calibration equipments, which is traceable to recognized national standards.

Especially, all antenna for measurement is calibrated in accordance with the requirements of C63.5 (Version : 2006).



## 1.5 Tested System Details

All equipment descriptions used in the tested system (including inserted cards) are:

Device Type	Model Name	Serial Number	Manufacturer	FCC ID / DoC
EUT	LM-X410UM	-	LG	ZNFX410UM
Data cable	EAD62377927	-	Ningbo	-
Data cable	EAD62377922	-	KSD	-
Earphone	EAB64168741	-	CRESYN	-
Notebook PC	ProBook6560b	5CB2053MXF	HP	DoC
Notebook PC adaptor	Series PPP009L-E	-	LITE-On Technology	-
RJ45 cable	-	-	-	-
Gateway	TL-WR747N	-	TP-LINK	-
Gateway adaptor	T120150-2H1	-	TP-LINK	-
Serial mouse	Serial 2 button mouse	02031069	Radio shack	FSUGMZE3
Micro SD card	256GB EVO+UHS-I microSDXC U1	-	SAMSUNG	-



## 1.6 Cable Description

Product Name	Port	Power Cord Shielded (Y/N)	I/O Cable Shielded (Y/N)	Length (m)
EUT	Micro USB	Y	Y	(P,D)1.0
	Earphone	N/A	Y	(D)1.2
Notebook PC	RJ 45	N/A	N	(D)1.6
	Serial (Mouse)	N/A	Y	(D)1.8
	DC in	N	N/A	(P)1.8
Gateway	DC in	N	N/A	(P)1.8

\* The marked “(D)” means the data cable and “(P)” means the power cable.

## 1.7 Noise Suppression Parts on Cable. (I/O Cable)

Product Name	Port	Ferrite Bead (Y/N)	Location	Metal Hood (Y/N)	Location
EUT	Micro USB	N	N/A	Y	Both End
	Earphone	N	N/A	Y	EUT End
Notebook PC	RJ 45	N	N/A	N	N/A
	Serial (Mouse)	N	N/A	Y	Notebook PC End



## 2. MEASUREMENT UNCERTAINTY

The measurement uncertainties shown below were calculated in accordance with the requirements of ANSI C63.4-2014.

All measurement uncertainty values are shown with a coverage factor of  $k = 2$  to indicate a 95 % level of confidence. The measurement data shown herein meets or exceeds the  $U_{\text{CISPR}}$  measurement uncertainty values specified in CISPR 16-4-2 and, thus, can be compared directly to specified limits to determine compliance.

Parameter	Expanded Uncertainty (dB)
Conducted Emission (0.15 MHz to 30 MHz)	1.82 dB ( $k = 2$ )
Radiated Emissions (30 MHz to 1 GHz)	5.20 dB ( $k = 2$ )
Radiated Emissions (1 GHz to 18 GHz)	5.24 dB ( $k = 2$ )
Radiated Emissions (18 GHz to 40 GHz)	5.40 dB ( $k = 2$ )





### 3. DESCRIPTION OF TEST

#### 3.1 Measurement of Conducted Emission

The test procedure was in accordance with ANSI C63.4-2014, Clause 7.3

- a. The EUT was placed 0.4 meters from the conducting wall of the shielded room with EUT being connected to the power mains through a line impedance stabilization network (LISN).  
If the EUT is connected to the PC through USB, the AC power-line adapter of the PC is directly connected to a line impedance stabilization network (LISN).  
Other support units were connected to the power mains through another LISN. The two LISNs provide 50 Ohm/ 50uH of coupling impedance for the measuring instrument.
- b. Both conducted lines are measured in Quasi-Peak and Average mode, including the worst-case data points for each tested configuration.
- c. The frequency range from 150 kHz to 30 MHz was searched.

#### [ Conducted Emission Limits ]

Frequency (MHz)	Resolution Bandwidth (kHz)	Quasi-Peak (dB(μV))	Average (dB(μV))
0.15 to 0.5	9	66 to 56*	56 to 46*
0.5 to 5	9	56	46
5 to 30	9	60	50

*\*Decreases with the logarithm of the frequency.*



## 3.2 Measurement of Radiated Emission

The test procedure was in accordance with ANSI C63.4-2014, Clause 8.3

- a. The EUT was placed on the top of a turn table 0.8 meters above the ground at a semi-anechoic chamber. The table was rotated 360 degrees to determine the position of the highest radiation.
- b. The EUT was set 3 m away from the interference-receiving antenna, which was mounted on the top of a variable-height antenna tower.
- c. The antenna height is varied from 1 m to 4 m above the ground to determine the maximum value of the field strength. Both horizontal and vertical polarizations of the antenna are set to make the measurement.
- d. For each suspected emission, the EUT was arranged to its worst case and then the antenna was tuned to heights from 1 m to 4 m and the turn table was turned from 0 degrees to 360 degrees to find the maximum reading.
- e. The test-receiver system was set to Quasi-Peak detect function and specified bandwidth with maximum hold mode when the test frequency is below 1 GHz.
- f. The test-receiver system was set to Peak and Average detect function and specified bandwidth with maximum hold mode when the test frequency is above 1 GHz.
- g. Place the measurement antenna away from each area of the EUT determined to be a source of emissions at the specified measurement distance, while keeping the measurement antenna aimed at the source of emissions at each frequency of significant emissions, with polarization oriented for maximum response.(1 GHz to 40 GHz)

### [ Radiated Emission Limits ]

Frequency (MHz)	Antenna Distance (m)	Field Strength ( $\mu\text{V}/\text{m}$ )	Quasi-Peak ( $\text{dB}(\mu\text{V})/\text{m}$ )
30 to 88	3	100	40.0
88 to 216	3	150	43.5
216 to 960	3	200	46.0
Above 960	3	500	54.0
Frequency (MHz)	Antenna Distance (m)	Peak ( $\text{dB}(\mu\text{V})/\text{m}$ )	Average ( $\text{dB}(\mu\text{V})/\text{m}$ )
Above 1 000	3	74	54



### 3.2.1 Frequency Range of Radiated Measurements

An unintentional radiator, including a digital device, the spectrum shall be investigated from the lowest radio frequency signal generated or used in the device, without going below the lowest frequency for which a Radiated Emission limit is specified, up to the frequency shown in the following table

Highest frequency generated or used in the device or on which the device operates or tunes (MHz)	Upper frequency of measurement range (MHz)
Below 1.705	30
1.705 to 108	1 000
108 to 500	2 000
500 to 1 000	5 000
Above 1 000	5 <sup>th</sup> harmonic of the highest frequency or 40 GHz, whichever is lower

### 3.3 Configuration of Tested System

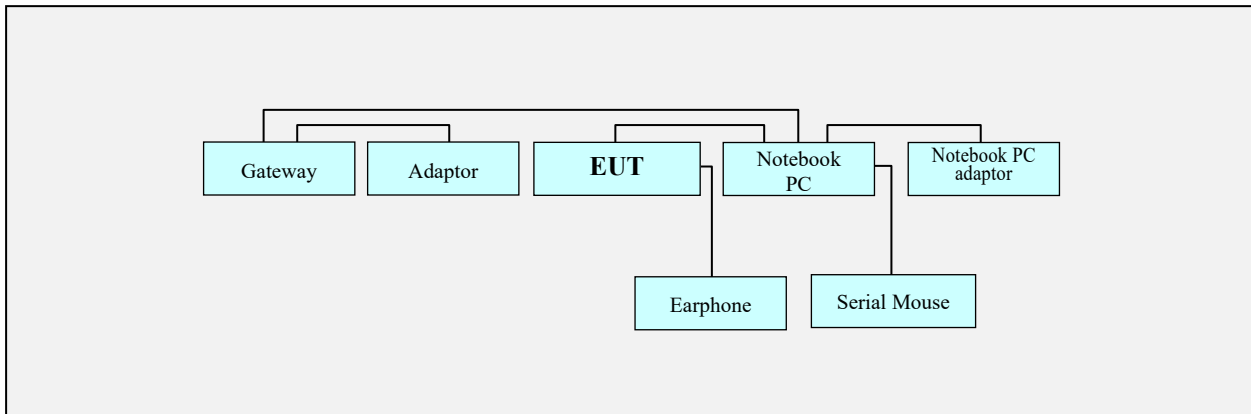

**Non-Conductive Table**  
 Power Line: 120 VAC, 60 Hz



## 4. PRELIMINARY TEST

### 4.1 Conducted Emission Test

It was tested Data Communication mode, after connecting all peripheral devices.

**Operation Mode:**       Data Communication mode

### 4.2 Radiated Emission Test

It was tested Data Communication mode, after connecting all peripheral devices.

**Operation Mode:**       Data Communication mode



## 5. CONDUCTED AND RADIATED EMISSION TEST SUMMARY

### 5.1 Conducted Emission Test

The test results of conducted emission at mains ports provide the following information:

Rule Part / Standard	FCC PART 15 Subpart B Class B
Detector	Quasi-Peak, CISPR-Average
Bandwidth	9 kHz (6 dB)
Operation Mode	Data Communication mode
Worst Data Cable	KSD (EAD62377922)
Kind of Test Site	Shielded Room
Temperature	21.4 °C
Relative Humidity	36.3 %
Test Date	January 24, 2018

#### - Calculation Formula:

1. Conductor L1 = Hot, Conductor N = Neutral
2. Corr. = LISN Factor + Cable Loss
3. QuasiPeak or CAverage= Receiver Reading + Corr.
4. Margin = Limit – QuasiPeak or CAverage



Figure 1: Conducted Emission, AC Main Port, Data Communication Mode, Line (L1)

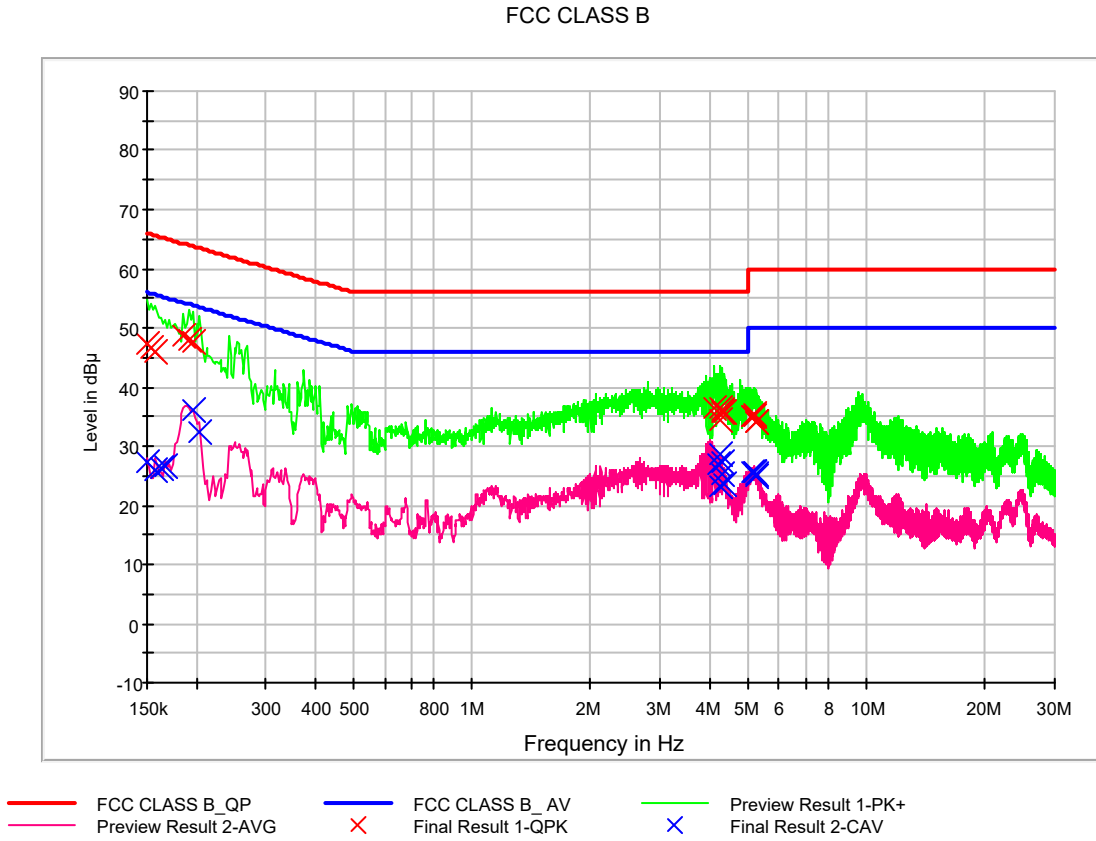



### QuasiPeak Final Result, Line (L1)

Frequency (MHz)	QuasiPeak (dBuV)	Bandwidth (kHz)	Line	Corr. (dB)	Margin (dB)	Limit (dBuV)
0.150000	47.2	9.000	L1	9.6	18.8	66.0
0.154000	46.5	9.000	L1	9.6	19.3	65.8
0.158000	46.0	9.000	L1	9.6	19.6	65.6
0.186000	48.7	9.000	L1	9.6	15.5	64.2
0.192000	48.0	9.000	L1	9.6	15.9	63.9
0.196000	47.7	9.000	L1	9.6	16.1	63.8
4.106000	36.6	9.000	L1	9.8	19.4	56.0
4.236000	36.5	9.000	L1	9.8	19.5	56.0
4.262000	34.5	9.000	L1	9.8	21.5	56.0
4.292000	35.8	9.000	L1	9.8	20.2	56.0
4.310000	36.2	9.000	L1	9.8	19.8	56.0
4.378000	35.8	9.000	L1	9.8	20.2	56.0
5.130000	35.2	9.000	L1	9.8	24.8	60.0
5.136000	35.0	9.000	L1	9.8	25.0	60.0
5.198000	35.5	9.000	L1	9.8	24.5	60.0
5.202000	35.3	9.000	L1	9.8	24.7	60.0
5.244000	34.2	9.000	L1	9.8	25.8	60.0
5.254000	34.1	9.000	L1	9.8	25.9	60.0



### CAverage Final Result, Line (L1)

Frequency (MHz)	CAverage (dBuV)	Bandwidth (kHz)	Line	Corr. (dB)	Margin (dB)	Limit (dBuV)
0.150000	27.3	9.000	L1	9.6	28.7	56.0
0.158000	25.9	9.000	L1	9.6	29.6	55.6
0.162000	26.3	9.000	L1	9.6	29.1	55.4
0.166000	26.8	9.000	L1	9.6	28.4	55.2
0.196000	36.0	9.000	L1	9.6	17.8	53.8
0.204000	32.4	9.000	L1	9.6	21.1	53.4
4.218000	27.0	9.000	L1	9.8	19.0	46.0
4.236000	28.6	9.000	L1	9.8	17.4	46.0
4.262000	23.3	9.000	L1	9.8	22.7	46.0
4.292000	27.2	9.000	L1	9.8	18.8	46.0
4.310000	25.4	9.000	L1	9.8	20.6	46.0
4.378000	23.6	9.000	L1	9.8	22.4	46.0
5.136000	25.5	9.000	L1	9.8	24.5	50.0
5.184000	25.7	9.000	L1	9.8	24.3	50.0
5.198000	25.6	9.000	L1	9.8	24.4	50.0
5.202000	25.5	9.000	L1	9.8	24.5	50.0
5.244000	25.2	9.000	L1	9.8	24.8	50.0
5.254000	24.9	9.000	L1	9.8	25.1	50.0





Figure 2: Conducted Emission, AC Main Port, Data Communication Mode, Line (N)

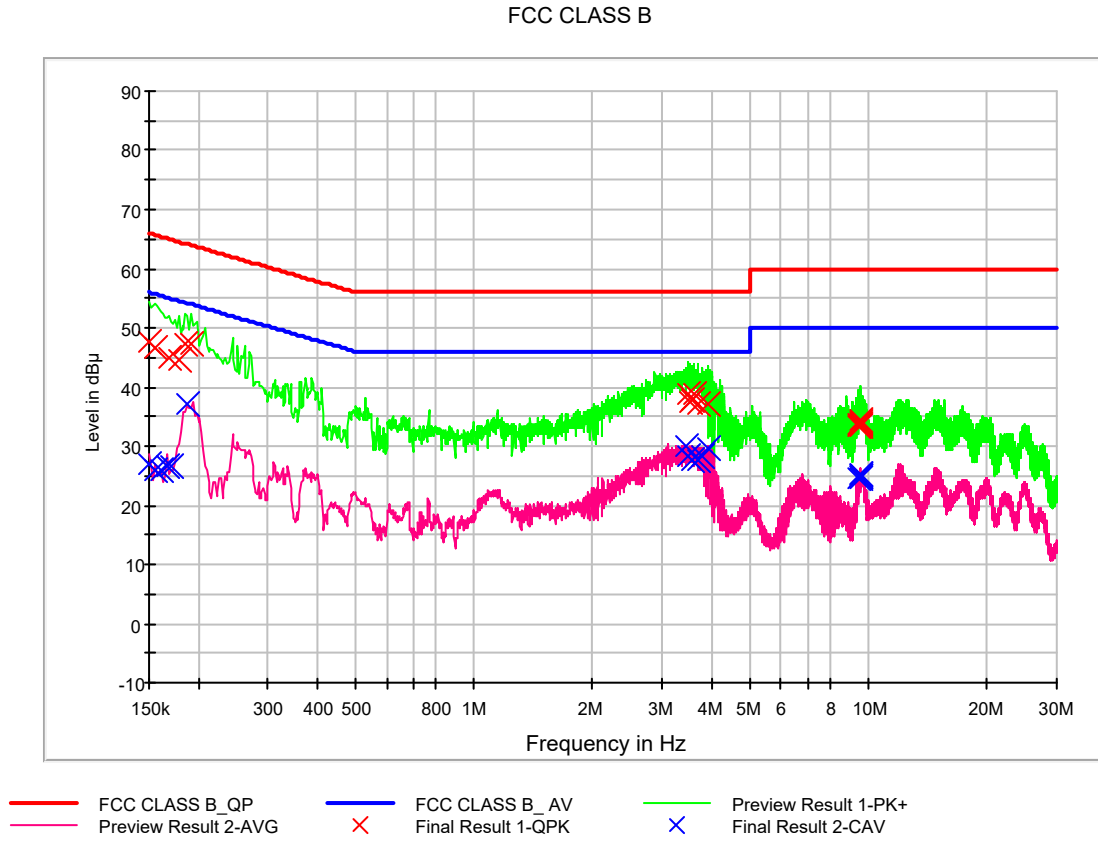



### QuasiPeak Final Result, Line (N)

Frequency (MHz)	QuasiPeak (dBuV)	Bandwidth (kHz)	Line	Corr. (dB)	Margin (dB)	Limit (dBuV)
0.150000	47.6	9.000	N	9.6	18.4	66.0
0.156000	46.7	9.000	N	9.6	19.0	65.7
0.168000	45.0	9.000	N	9.6	20.1	65.1
0.178000	44.6	9.000	N	9.6	20.0	64.6
0.186000	47.4	9.000	N	9.6	16.8	64.2
0.192000	47.2	9.000	N	9.6	16.8	63.9
3.490000	38.7	9.000	N	9.8	17.3	56.0
3.542000	37.5	9.000	N	9.8	18.5	56.0
3.556000	37.6	9.000	N	9.8	18.4	56.0
3.630000	38.8	9.000	N	9.8	17.2	56.0
3.698000	37.2	9.000	N	9.8	18.8	56.0
3.904000	37.2	9.000	N	9.8	18.8	56.0
9.440000	33.8	9.000	N	10.0	26.2	60.0
9.464000	33.5	9.000	N	10.0	26.5	60.0
9.496000	34.3	9.000	N	10.0	25.7	60.0
9.504000	33.8	9.000	N	10.0	26.2	60.0
9.548000	33.5	9.000	N	10.0	26.5	60.0
9.552000	33.9	9.000	N	10.0	26.1	60.0



## CAverage Final Result, Line (N)

Frequency (MHz)	CAverage (dBuV)	Bandwidth (kHz)	Line	Corr. (dB)	Margin (dB)	Limit (dBuV)
0.150000	26.9	9.000	N	9.6	29.1	56.0
0.156000	25.9	9.000	N	9.6	29.8	55.7
0.160000	25.9	9.000	N	9.6	29.6	55.5
0.166000	26.5	9.000	N	9.6	28.7	55.2
0.170000	26.8	9.000	N	9.6	28.2	55.0
0.188000	37.0	9.000	N	9.6	17.2	54.1
3.446000	30.0	9.000	N	9.8	16.0	46.0
3.490000	28.4	9.000	N	9.8	17.6	46.0
3.556000	27.8	9.000	N	9.8	18.2	46.0
3.698000	27.5	9.000	N	9.8	18.5	46.0
3.794000	28.2	9.000	N	9.8	17.8	46.0
3.904000	29.7	9.000	N	9.8	16.3	46.0
9.464000	24.7	9.000	N	10.0	25.3	50.0
9.488000	24.6	9.000	N	10.0	25.4	50.0
9.496000	25.2	9.000	N	10.0	24.8	50.0
9.530000	25.2	9.000	N	10.0	24.8	50.0
9.552000	25.1	9.000	N	10.0	24.9	50.0
9.568000	25.0	9.000	N	10.0	25.0	50.0



## 5.2 Radiated Emission Test

The test results of radiated emission provide the following information:

### -For Measurement Below 1 GHz

Rule Part / Standard	FCC PART 15 Subpart B Class B
Detector	Quasi-Peak
Bandwidth	120 kHz (6 dB)
Operation Mode	Data Communication mode
Worst Data Cable	KSD (EAD62377922)
Kind of Test Site	3 m semi anechoic chamber
Temperature	21.1 °C
Relative Humidity	37.0 %
Test Date	January 19, 2018

Frequency (MHz)	Quasi Peak (dB $\mu$ V/m)	Antenna Height (cm)	POL. (H/V)	Azimuth (deg)	Corr. (dB)	Margin (dB)	Limit (dB $\mu$ V/m)
30.239846	27.0	100.0	V	293.0	21.7	13.0	40.0
87.164800	32.6	265.0	H	294.0	17.9	7.4	40.0
133.256000	27.5	174.0	H	312.0	22.3	16.0	43.5
265.620000	33.0	133.0	H	339.0	22.8	13.0	46.0
600.034400	37.8	350.0	H	47.0	31.3	8.2	46.0
914.696800	35.2	350.0	V	72.0	35.3	10.8	46.0

### - Calculation Formula:

1. POL. H = Horizontal, POL. V = Vertical
2. QuasiPeak = Reading (Receiver Reading) + Corr.
3. Corr. (Correction Factor) = Antenna Factor + Cable Loss
4. Margin = Limit - QuasiPeak



## -For Measurement Above 1 GHz

Rule Part / Standard	FCC PART 15 Subpart B Class B
Detector	Peak mode: Peak (RBW: 1 MHz, VBW: 3 MHz) CISPR-Average mode: Peak (RBW: 1 MHz, VBW: 10 Hz)
Highest Operating Frequency	5 825 MHz
Upper Frequency	1 GHz to 29.125 GHz
Operation Mode	Data Communication mode
Worst Data Cable	KSD (EAD62377922)
Kind of Test Site	3 m semi anechoic chamber
Temperature	21.1 / 20.5 °C
Relative Humidity	37.0 / 36.2 %
Test Date	January 19 / January 22, 2018

Frequency (MHz)	Peak (dB $\mu$ V/m)	Antenna Height (cm)	POL. (H/V)	Azimuth (deg)	Corr. (dB)	Margin (dB)	Limit (dB $\mu$ V/m)
1400.145000	49.8	305.3	V	228.0	-12.9	24.2	74.0
1499.280000	44.7	320.3	V	0.0	-12.6	29.3	74.0
1999.365000	51.1	99.8	V	48.0	-11.8	22.9	74.0
2665.885000	45.6	250.2	V	53.0	-9.4	28.4	74.0
4492.920000	42.2	217.7	V	6.0	-5.4	31.8	74.0
5999.385000	46.1	277.6	V	103.0	-2.2	27.9	74.0

Frequency (MHz)	CAverage (dB $\mu$ V/m)	Antenna Height (cm)	POL. (H/V)	Azimuth (deg)	Corr. (dB)	Margin (dB)	Limit (dB $\mu$ V/m)
1400.145000	38.2	305.3	V	228.0	-12.9	15.8	54.0
1499.280000	37.4	320.3	V	0.0	-12.6	16.6	54.0
1999.365000	27.2	99.8	V	48.0	-11.8	26.8	54.0
2665.885000	23.1	250.2	V	53.0	-9.4	30.9	54.0
4492.920000	27.2	217.7	V	6.0	-5.4	26.8	54.0
5999.385000	28.8	277.6	V	103.0	-2.2	25.2	54.0

### - Calculation Formula:

1. POL. H = Horizontal, POL. V = Vertical
2. Peak or CAverage = Reading (Receiver Reading) + Corr.
3. Corr. (Correction Factor) = Antenna Factor+ Cable Loss –Amplifier Gain
4. Margin = Limit - Peak or CAverage



## 6. LIST OF TEST EQUIPMENT

<u>Type</u>	<u>Manufacturer</u>	<u>Model Name</u>	<u>Serial Number</u>	<u>Calibration Cycle</u>	<u>CAL Date</u>
<u>Conducted Emission</u>					
<input type="checkbox"/> EMI Test Receiver	Rohde & Schwarz	ESCI	100584	1 year	06.20.2017
<input checked="" type="checkbox"/> EMI Test Receiver	Rohde & Schwarz	ESCI	100033	1 year	06.27.2017
<input checked="" type="checkbox"/> LISN	Rohde & Schwarz	ENV216	102245	1 year	12.20.2017
<input checked="" type="checkbox"/> LISN	Rohde & Schwarz	ESH3-Z5	100282	1 year	05.22.2017
<input type="checkbox"/> LISN	Rohde & Schwarz	ENV216	100073	1 year	07.18.2017
<input checked="" type="checkbox"/> Software	Rohde & Schwarz	EMC32 VER8.54.0	-	-	-
<u>Radiated Emission</u>					
-For measurement below 1 GHz					
<input checked="" type="checkbox"/> EMI Test Receiver	Rohde & Schwarz	ESU40	100524	1 year	08.16.2017
<input checked="" type="checkbox"/> Trilog Antenna	Schwarzbeck	VULB 9168	760	2 year	04.06.2017
<input checked="" type="checkbox"/> Antenna master	HD GmbH	MA240	240/520	N/A	-
<input checked="" type="checkbox"/> Antenna master controller	HD GmbH	HD 100	100/637	N/A	-
<input checked="" type="checkbox"/> Turn Table	INNCO Systems	-	-	N/A	-
<input checked="" type="checkbox"/> Turn Table controller	INNCO Systems	CO2000	-	N/A	-
<input type="checkbox"/> EMI Test Receiver	Rohde & Schwarz	ESU26	100241	1 year	08.16.2017
<input type="checkbox"/> Antenna master	INNCO Systems	MA4000-EP	MA4000/283	N/A	-
<input type="checkbox"/> Turn Table	INNCO Systems	DT3000-3T	DT3000/69	N/A	-
<input checked="" type="checkbox"/> Software	Rohde & Schwarz	EMC32 VER8.40.0	-	-	-
-For measurement above 1 GHz					
<input checked="" type="checkbox"/> EMI Test Receiver	Rohde & Schwarz	ESU40	100524	1 year	08.16.2017
<input checked="" type="checkbox"/> Antenna master	INNCO Systems	MA4000-XP-ET	-	N/A	-
<input checked="" type="checkbox"/> Antenna master controller	INNCO Systems	CO 3000	CO 3000/870/ 35990515/L	N/A	-
<input checked="" type="checkbox"/> Turn Table	INNCO Systems	-	-	N/A	-
<input checked="" type="checkbox"/> Turn Table controller	INNCO Systems	CO2000	-	N/A	-
<input checked="" type="checkbox"/> Power Amplifier	CERNEX	CBLU5183530	24348	1 year	06.01.2017
<input checked="" type="checkbox"/> Power Amplifier	CERNEX	CBL18265035	21873	1 year	01.10.2018
<input checked="" type="checkbox"/> Power Amplifier	CERNEX	CBL26405040	19660	1 year	07.11.2017
<input checked="" type="checkbox"/> Horn Antenna	Schwarzbeck	BBHA 9120D	296	2 year	10.12.2016
<input checked="" type="checkbox"/> Horn Antenna	Schwarzbeck	BBHA 9170	BBHA9170124	2 year	04.25.2017
<input type="checkbox"/> Antenna master controller	HD GmbH	HD 100	100/637	N/A	-
<input type="checkbox"/> Power Amplifier	CERNEX	CBLU1183540	21691	1 year	06.28.2017
<input type="checkbox"/> Antenna master	HD GmbH	MA240	240/520	N/A	-
<input type="checkbox"/> Horn Antenna	Schwarzbeck	BBHA 9120D	1300	2 year	06.30.2017
<input type="checkbox"/> EMI Test Receiver	Rohde & Schwarz	ESU26	100241	1 year	08.16.2017
<input type="checkbox"/> Turn Table	INNCO Systems	DT3000-3T	DT3000/69	N/A	-
<input checked="" type="checkbox"/> Software	Rohde & Schwarz	EMC32 VER8.40.0	-	-	-



## 7. CONCLUSION

The data collected shows that the **EUT Type: Multi-band CDMA/GSM/WCMDA/LTE Phone with BT and WLAN, Model: LM-X410UM, FCC ID: ZNFX410UM** complies with §15.107 and §15.109 of the FCC rules.



## 8. APPENDIX A. TEST SETUP PHOTOGRAPHS

Please refer to Appendix A