

10460-AAA	UMTS-FDD (WCDMA, AMR)	X	3.37	95.81	29.07	0.00	150.0	± 9.6 %
		Y	1.74	81.67	23.23		150.0	
		Z	1.21	74.42	19.58		150.0	
10461-AAA	LTE-TDD (SC-FDMA, 1 RB, 1.4 MHz, QPSK, UL Subframe=2,3,4,7,8,9)	X	100.00	143.01	40.15	3.29	80.0	± 9.6 %
		Y	100.00	134.90	36.63		80.0	
		Z	100.00	132.97	35.44		80.0	
10462-AAA	LTE-TDD (SC-FDMA, 1 RB, 1.4 MHz, 16-QAM, UL Subframe=2,3,4,7,8,9)	X	100.00	119.25	28.85	3.23	80.0	± 9.6 %
		Y	100.00	113.20	26.37		80.0	
		Z	100.00	110.00	24.63		80.0	
10463-AAA	LTE-TDD (SC-FDMA, 1 RB, 1.4 MHz, 64-QAM, UL Subframe=2,3,4,7,8,9)	X	100.00	113.75	26.28	3.23	80.0	± 9.6 %
		Y	100.00	108.57	24.18		80.0	
		Z	100.00	105.07	22.33		80.0	
10464-AAA	LTE-TDD (SC-FDMA, 1 RB, 3 MHz, QPSK, UL Subframe=2,3,4,7,8,9)	X	100.00	141.23	39.11	3.23	80.0	± 9.6 %
		Y	100.00	132.81	35.48		80.0	
		Z	100.00	130.60	34.16		80.0	
10465-AAA	LTE-TDD (SC-FDMA, 1 RB, 3 MHz, 16-QAM, UL Subframe=2,3,4,7,8,9)	X	100.00	118.41	28.46	3.23	80.0	± 9.6 %
		Y	100.00	112.48	26.02		80.0	
		Z	100.00	109.28	24.29		80.0	
10466-AAA	LTE-TDD (SC-FDMA, 1 RB, 3 MHz, 64-QAM, UL Subframe=2,3,4,7,8,9)	X	100.00	112.90	25.90	3.23	80.0	± 9.6 %
		Y	100.00	107.89	23.87		80.0	
		Z	100.00	104.43	22.04		80.0	
10467-AAC	LTE-TDD (SC-FDMA, 1 RB, 5 MHz, QPSK, UL Subframe=2,3,4,7,8,9)	X	100.00	141.61	39.28	3.23	80.0	± 9.6 %
		Y	100.00	133.15	35.63		80.0	
		Z	100.00	130.94	34.31		80.0	
10468-AAC	LTE-TDD (SC-FDMA, 1 RB, 5 MHz, 16-QAM, UL Subframe=2,3,4,7,8,9)	X	100.00	118.75	28.61	3.23	80.0	± 9.6 %
		Y	100.00	112.75	26.15		80.0	
		Z	100.00	109.56	24.42		80.0	
10469-AAC	LTE-TDD (SC-FDMA, 1 RB, 5 MHz, 64-QAM, UL Subframe=2,3,4,7,8,9)	X	100.00	112.98	25.93	3.23	80.0	± 9.6 %
		Y	100.00	107.94	23.89		80.0	
		Z	100.00	104.47	22.05		80.0	
10470-AAC	LTE-TDD (SC-FDMA, 1 RB, 10 MHz, QPSK, UL Subframe=2,3,4,7,8,9)	X	100.00	141.70	39.31	3.23	80.0	± 9.6 %
		Y	100.00	133.21	35.65		80.0	
		Z	100.00	130.98	34.32		80.0	
10471-AAC	LTE-TDD (SC-FDMA, 1 RB, 10 MHz, 16-QAM, UL Subframe=2,3,4,7,8,9)	X	100.00	118.69	28.58	3.23	80.0	± 9.6 %
		Y	100.00	112.69	26.12		80.0	
		Z	100.00	109.48	24.38		80.0	
10472-AAC	LTE-TDD (SC-FDMA, 1 RB, 10 MHz, 64-QAM, UL Subframe=2,3,4,7,8,9)	X	100.00	112.90	25.89	3.23	80.0	± 9.6 %
		Y	100.00	107.86	23.85		80.0	
		Z	100.00	104.38	22.01		80.0	
10473-AAC	LTE-TDD (SC-FDMA, 1 RB, 15 MHz, QPSK, UL Subframe=2,3,4,7,8,9)	X	100.00	141.67	39.29	3.23	80.0	± 9.6 %
		Y	100.00	133.18	35.63		80.0	
		Z	100.00	130.96	34.31		80.0	
10474-AAC	LTE-TDD (SC-FDMA, 1 RB, 15 MHz, 16-QAM, UL Subframe=2,3,4,7,8,9)	X	100.00	118.71	28.58	3.23	80.0	± 9.6 %
		Y	100.00	112.70	26.12		80.0	
		Z	100.00	109.49	24.38		80.0	
10475-AAC	LTE-TDD (SC-FDMA, 1 RB, 15 MHz, 64-QAM, UL Subframe=2,3,4,7,8,9)	X	100.00	112.93	25.90	3.23	80.0	± 9.6 %
		Y	100.00	107.88	23.85		80.0	
		Z	100.00	104.40	22.02		80.0	

10477-AAC	LTE-TDD (SC-FDMA, 1 RB, 20 MHz, 16-QAM, UL Subframe=2,3,4,7,8,9)	X	100.00	118.43	28.45	3.23	80.0	± 9.6 %
		Y	100.00	112.46	26.00		80.0	
		Z	100.00	109.24	24.26		80.0	
10478-AAC	LTE-TDD (SC-FDMA, 1 RB, 20 MHz, 64-QAM, UL Subframe=2,3,4,7,8,9)	X	100.00	112.82	25.85	3.23	80.0	± 9.6 %
		Y	100.00	107.79	23.82		80.0	
		Z	100.00	104.31	21.98		80.0	
10479-AAA	LTE-TDD (SC-FDMA, 50% RB, 1.4 MHz, QPSK, UL Subframe=2,3,4,7,8,9)	X	100.00	132.85	37.00	3.23	80.0	± 9.6 %
		Y	100.00	128.47	35.00		80.0	
		Z	100.00	127.00	34.04		80.0	
10480-AAA	LTE-TDD (SC-FDMA, 50% RB, 1.4 MHz, 16-QAM, UL Subframe=2,3,4,7,8,9)	X	100.00	120.16	30.90	3.23	80.0	± 9.6 %
		Y	100.00	116.69	29.36		80.0	
		Z	100.00	114.91	28.26		80.0	
10481-AAA	LTE-TDD (SC-FDMA, 50% RB, 1.4 MHz, 64-QAM, UL Subframe=2,3,4,7,8,9)	X	100.00	117.70	29.67	3.23	80.0	± 9.6 %
		Y	100.00	114.39	28.21		80.0	
		Z	100.00	112.46	27.04		80.0	
10482-AAA	LTE-TDD (SC-FDMA, 50% RB, 3 MHz, QPSK, UL Subframe=2,3,4,7,8,9)	X	100.00	122.13	31.51	2.23	80.0	± 9.6 %
		Y	54.92	111.25	28.42		80.0	
		Z	13.32	91.56	22.86		80.0	
10483-AAA	LTE-TDD (SC-FDMA, 50% RB, 3 MHz, 16-QAM, UL Subframe=2,3,4,7,8,9)	X	100.00	116.38	29.36	2.23	80.0	± 9.6 %
		Y	100.00	113.46	28.01		80.0	
		Z	11.26	84.75	19.89		80.0	
10484-AAA	LTE-TDD (SC-FDMA, 50% RB, 3 MHz, 64-QAM, UL Subframe=2,3,4,7,8,9)	X	100.00	115.90	29.19	2.23	80.0	± 9.6 %
		Y	50.77	104.49	25.86		80.0	
		Z	8.43	80.95	18.67		80.0	
10485-AAC	LTE-TDD (SC-FDMA, 50% RB, 5 MHz, QPSK, UL Subframe=2,3,4,7,8,9)	X	65.25	120.82	33.02	2.23	80.0	± 9.6 %
		Y	24.29	103.39	28.10		80.0	
		Z	11.52	91.94	24.54		80.0	
10486-AAC	LTE-TDD (SC-FDMA, 50% RB, 5 MHz, 16-QAM, UL Subframe=2,3,4,7,8,9)	X	10.69	87.70	22.97	2.23	80.0	± 9.6 %
		Y	8.09	82.63	21.00		80.0	
		Z	5.71	77.63	18.94		80.0	
10487-AAC	LTE-TDD (SC-FDMA, 50% RB, 5 MHz, 64-QAM, UL Subframe=2,3,4,7,8,9)	X	9.28	85.21	22.13	2.23	80.0	± 9.6 %
		Y	7.33	80.85	20.36		80.0	
		Z	5.35	76.37	18.44		80.0	
10488-AAC	LTE-TDD (SC-FDMA, 50% RB, 10 MHz, QPSK, UL Subframe=2,3,4,7,8,9)	X	11.48	93.02	26.74	2.23	80.0	± 9.6 %
		Y	9.12	87.88	24.67		80.0	
		Z	6.88	83.40	22.96		80.0	
10489-AAC	LTE-TDD (SC-FDMA, 50% RB, 10 MHz, 16-QAM, UL Subframe=2,3,4,7,8,9)	X	6.05	78.94	21.72	2.23	80.0	± 9.6 %
		Y	5.74	77.30	20.79		80.0	
		Z	4.98	75.13	19.74		80.0	
10490-AAC	LTE-TDD (SC-FDMA, 50% RB, 10 MHz, 64-QAM, UL Subframe=2,3,4,7,8,9)	X	5.92	78.02	21.35	2.23	80.0	± 9.6 %
		Y	5.66	76.55	20.49		80.0	
		Z	4.96	74.57	19.51		80.0	
10491-AAC	LTE-TDD (SC-FDMA, 50% RB, 15 MHz, QPSK, UL Subframe=2,3,4,7,8,9)	X	7.36	83.03	23.55	2.23	80.0	± 9.6 %
		Y	6.73	80.60	22.34		80.0	
		Z	5.73	78.11	21.25		80.0	
10492-AAC	LTE-TDD (SC-FDMA, 50% RB, 15 MHz, 16-QAM, UL Subframe=2,3,4,7,8,9)	X	5.42	74.92	20.52	2.23	80.0	± 9.6 %
		Y	5.33	74.03	19.90		80.0	
		Z	4.87	72.71	19.18		80.0	

10493-AAC	LTE-TDD (SC-FDMA, 50% RB, 15 MHz, 64-QAM, UL Subframe=2,3,4,7,8,9)	X	5.40	74.45	20.32	2.23	80.0	± 9.6 %
		Y	5.32	73.63	19.73		80.0	
		Z	4.88	72.39	19.05		80.0	
10494-AAC	LTE-TDD (SC-FDMA, 50% RB, 20 MHz, QPSK, UL Subframe=2,3,4,7,8,9)	X	9.17	86.80	24.72	2.23	80.0	± 9.6 %
		Y	8.03	83.58	23.27		80.0	
		Z	6.60	80.52	22.02		80.0	
10495-AAC	LTE-TDD (SC-FDMA, 50% RB, 20 MHz, 16-QAM, UL Subframe=2,3,4,7,8,9)	X	5.52	75.46	20.81	2.23	80.0	± 9.6 %
		Y	5.42	74.52	20.17		80.0	
		Z	4.93	73.12	19.44		80.0	
10496-AAC	LTE-TDD (SC-FDMA, 50% RB, 20 MHz, 64-QAM, UL Subframe=2,3,4,7,8,9)	X	5.45	74.64	20.50	2.23	80.0	± 9.6 %
		Y	5.38	73.84	19.92		80.0	
		Z	4.93	72.57	19.24		80.0	
10497-AAA	LTE-TDD (SC-FDMA, 100% RB, 1.4 MHz, QPSK, UL Subframe=2,3,4,7,8,9)	X	100.00	115.27	27.88	2.23	80.0	± 9.6 %
		Y	25.28	96.48	22.93		80.0	
		Z	5.87	78.71	17.31		80.0	
10498-AAA	LTE-TDD (SC-FDMA, 100% RB, 1.4 MHz, 16-QAM, UL Subframe=2,3,4,7,8,9)	X	2.96	68.45	12.76	2.23	80.0	± 9.6 %
		Y	2.21	64.78	11.01		80.0	
		Z	1.67	62.18	9.40		80.0	
10499-AAA	LTE-TDD (SC-FDMA, 100% RB, 1.4 MHz, 64-QAM, UL Subframe=2,3,4,7,8,9)	X	2.39	65.91	11.50	2.23	80.0	± 9.6 %
		Y	1.96	63.35	10.16		80.0	
		Z	1.55	61.26	8.77		80.0	
10500-AAA	LTE-TDD (SC-FDMA, 100% RB, 3 MHz, QPSK, UL Subframe=2,3,4,7,8,9)	X	21.96	103.85	29.24	2.23	80.0	± 9.6 %
		Y	13.48	94.40	26.05		80.0	
		Z	8.53	87.25	23.57		80.0	
10501-AAA	LTE-TDD (SC-FDMA, 100% RB, 3 MHz, 16-QAM, UL Subframe=2,3,4,7,8,9)	X	8.02	83.54	22.29	2.23	80.0	± 9.6 %
		Y	6.90	80.32	20.86		80.0	
		Z	5.43	76.80	19.30		80.0	
10502-AAA	LTE-TDD (SC-FDMA, 100% RB, 3 MHz, 64-QAM, UL Subframe=2,3,4,7,8,9)	X	7.77	82.58	21.87	2.23	80.0	± 9.6 %
		Y	6.74	79.56	20.50		80.0	
		Z	5.37	76.23	19.00		80.0	
10503-AAC	LTE-TDD (SC-FDMA, 100% RB, 5 MHz, QPSK, UL Subframe=2,3,4,7,8,9)	X	11.17	92.54	26.57	2.23	80.0	± 9.6 %
		Y	8.90	87.45	24.51		80.0	
		Z	6.74	83.07	22.83		80.0	
10504-AAC	LTE-TDD (SC-FDMA, 100% RB, 5 MHz, 16-QAM, UL Subframe=2,3,4,7,8,9)	X	6.00	78.78	21.64	2.23	80.0	± 9.6 %
		Y	5.69	77.13	20.71		80.0	
		Z	4.94	74.99	19.66		80.0	
10505-AAC	LTE-TDD (SC-FDMA, 100% RB, 5 MHz, 64-QAM, UL Subframe=2,3,4,7,8,9)	X	5.88	77.87	21.28	2.23	80.0	± 9.6 %
		Y	5.62	76.40	20.42		80.0	
		Z	4.93	74.45	19.44		80.0	
10506-AAC	LTE-TDD (SC-FDMA, 100% RB, 10 MHz, QPSK, UL Subframe=2,3,4,7,8,9)	X	9.03	86.51	24.60	2.23	80.0	± 9.6 %
		Y	7.91	83.32	23.16		80.0	
		Z	6.52	80.31	21.93		80.0	
10507-AAC	LTE-TDD (SC-FDMA, 100% RB, 10 MHz, 16-QAM, UL Subframe=2,3,4,7,8,9)	X	5.50	75.38	20.77	2.23	80.0	± 9.6 %
		Y	5.39	74.44	20.13		80.0	
		Z	4.91	73.05	19.40		80.0	

10508-AAC	LTE-TDD (SC-FDMA, 100% RB, 10 MHz, 64-QAM, UL Subframe=2,3,4,7,8,9)	X	5.43	74.55	20.45	2.23	80.0	± 9.6 %
		Y	5.35	73.74	19.86		80.0	
		Z	4.91	72.49	19.19		80.0	
10509-AAC	LTE-TDD (SC-FDMA, 100% RB, 15 MHz, QPSK, UL Subframe=2,3,4,7,8,9)	X	7.27	80.16	22.31	2.23	80.0	± 9.6 %
		Y	6.86	78.46	21.40		80.0	
		Z	6.07	76.60	20.55		80.0	
10510-AAC	LTE-TDD (SC-FDMA, 100% RB, 15 MHz, 16-QAM, UL Subframe=2,3,4,7,8,9)	X	5.60	73.37	20.04	2.23	80.0	± 9.6 %
		Y	5.56	72.76	19.56		80.0	
		Z	5.19	71.77	19.01		80.0	
10511-AAC	LTE-TDD (SC-FDMA, 100% RB, 15 MHz, 64-QAM, UL Subframe=2,3,4,7,8,9)	X	5.57	72.82	19.83	2.23	80.0	± 9.6 %
		Y	5.55	72.29	19.39		80.0	
		Z	5.21	71.39	18.87		80.0	
10512-AAC	LTE-TDD (SC-FDMA, 100% RB, 20 MHz, QPSK, UL Subframe=2,3,4,7,8,9)	X	8.90	84.26	23.64	2.23	80.0	± 9.6 %
		Y	8.02	81.72	22.45		80.0	
		Z	6.83	79.22	21.40		80.0	
10513-AAC	LTE-TDD (SC-FDMA, 100% RB, 20 MHz, 16-QAM, UL Subframe=2,3,4,7,8,9)	X	5.59	74.00	20.32	2.23	80.0	± 9.6 %
		Y	5.54	73.30	19.79		80.0	
		Z	5.13	72.20	19.19		80.0	
10514-AAC	LTE-TDD (SC-FDMA, 100% RB, 20 MHz, 64-QAM, UL Subframe=2,3,4,7,8,9)	X	5.48	73.14	20.00	2.23	80.0	± 9.6 %
		Y	5.45	72.55	19.53		80.0	
		Z	5.09	71.56	18.98		80.0	
10515-AAA	IEEE 802.11b WiFi 2.4 GHz (DSSS, 2 Mbps, 99pc duty cycle)	X	1.15	67.44	18.30	0.00	150.0	± 9.6 %
		Y	1.10	66.10	17.12		150.0	
		Z	1.04	64.87	15.98		150.0	
10516-AAA	IEEE 802.11b WiFi 2.4 GHz (DSSS, 5.5 Mbps, 99pc duty cycle)	X	100.00	185.02	53.92	0.00	150.0	± 9.6 %
		Y	4.08	110.19	34.01		150.0	
		Z	1.21	84.34	24.35		150.0	
10517-AAA	IEEE 802.11b WiFi 2.4 GHz (DSSS, 11 Mbps, 99pc duty cycle)	X	1.23	74.63	21.82	0.00	150.0	± 9.6 %
		Y	1.06	70.88	19.41		150.0	
		Z	0.94	68.06	17.43		150.0	
10518-AAA	IEEE 802.11a/h WiFi 5 GHz (OFDM, 9 Mbps, 99pc duty cycle)	X	4.59	67.92	17.08	0.00	150.0	± 9.6 %
		Y	4.55	67.66	16.83		150.0	
		Z	4.47	67.43	16.55		150.0	
10519-AAA	IEEE 802.11a/h WiFi 5 GHz (OFDM, 12 Mbps, 99pc duty cycle)	X	4.75	68.08	17.16	0.00	150.0	± 9.6 %
		Y	4.71	67.83	16.91		150.0	
		Z	4.62	67.60	16.63		150.0	
10520-AAA	IEEE 802.11a/h WiFi 5 GHz (OFDM, 18 Mbps, 99pc duty cycle)	X	4.61	68.08	17.11	0.00	150.0	± 9.6 %
		Y	4.57	67.81	16.85		150.0	
		Z	4.48	67.55	16.56		150.0	
10521-AAA	IEEE 802.11a/h WiFi 5 GHz (OFDM, 24 Mbps, 99pc duty cycle)	X	4.55	68.08	17.11	0.00	150.0	± 9.6 %
		Y	4.50	67.80	16.85		150.0	
		Z	4.42	67.54	16.55		150.0	
10522-AAA	IEEE 802.11a/h WiFi 5 GHz (OFDM, 36 Mbps, 99pc duty cycle)	X	4.61	68.22	17.21	0.00	150.0	± 9.6 %
		Y	4.56	67.94	16.95		150.0	
		Z	4.47	67.67	16.65		150.0	

10523-AAA	IEEE 802.11a/h WiFi 5 GHz (OFDM, 48 Mbps, 99pc duty cycle)	X	4.52	68.18	17.12	0.00	150.0	± 9.6 %
		Y	4.48	67.89	16.85		150.0	
		Z	4.39	67.64	16.56		150.0	
10524-AAA	IEEE 802.11a/h WiFi 5 GHz (OFDM, 54 Mbps, 99pc duty cycle)	X	4.56	68.16	17.20	0.00	150.0	± 9.6 %
		Y	4.51	67.87	16.93		150.0	
		Z	4.42	67.62	16.64		150.0	
10525-AAA	IEEE 802.11ac WiFi (20MHz, MCS0, 99pc duty cycle)	X	4.58	67.22	16.79	0.00	150.0	± 9.6 %
		Y	4.53	66.96	16.53		150.0	
		Z	4.45	66.71	16.25		150.0	
10526-AAA	IEEE 802.11ac WiFi (20MHz, MCS1, 99pc duty cycle)	X	4.73	67.55	16.92	0.00	150.0	± 9.6 %
		Y	4.68	67.28	16.66		150.0	
		Z	4.58	67.01	16.37		150.0	
10527-AAA	IEEE 802.11ac WiFi (20MHz, MCS2, 99pc duty cycle)	X	4.66	67.55	16.87	0.00	150.0	± 9.6 %
		Y	4.61	67.26	16.61		150.0	
		Z	4.51	66.98	16.31		150.0	
10528-AAA	IEEE 802.11ac WiFi (20MHz, MCS3, 99pc duty cycle)	X	4.67	67.56	16.90	0.00	150.0	± 9.6 %
		Y	4.62	67.27	16.64		150.0	
		Z	4.53	67.00	16.34		150.0	
10529-AAA	IEEE 802.11ac WiFi (20MHz, MCS4, 99pc duty cycle)	X	4.67	67.56	16.90	0.00	150.0	± 9.6 %
		Y	4.62	67.27	16.64		150.0	
		Z	4.53	67.00	16.34		150.0	
10531-AAA	IEEE 802.11ac WiFi (20MHz, MCS6, 99pc duty cycle)	X	4.65	67.64	16.91	0.00	150.0	± 9.6 %
		Y	4.60	67.34	16.64		150.0	
		Z	4.50	67.04	16.33		150.0	
10532-AAA	IEEE 802.11ac WiFi (20MHz, MCS7, 99pc duty cycle)	X	4.52	67.51	16.86	0.00	150.0	± 9.6 %
		Y	4.47	67.22	16.59		150.0	
		Z	4.37	66.91	16.27		150.0	
10533-AAA	IEEE 802.11ac WiFi (20MHz, MCS8, 99pc duty cycle)	X	4.68	67.65	16.91	0.00	150.0	± 9.6 %
		Y	4.63	67.36	16.65		150.0	
		Z	4.53	67.08	16.35		150.0	
10534-AAA	IEEE 802.11ac WiFi (40MHz, MCS0, 99pc duty cycle)	X	5.20	67.39	16.83	0.00	150.0	± 9.6 %
		Y	5.16	67.18	16.61		150.0	
		Z	5.07	66.93	16.35		150.0	
10535-AAA	IEEE 802.11ac WiFi (40MHz, MCS1, 99pc duty cycle)	X	5.27	67.58	16.92	0.00	150.0	± 9.6 %
		Y	5.22	67.35	16.70		150.0	
		Z	5.12	67.09	16.43		150.0	
10536-AAA	IEEE 802.11ac WiFi (40MHz, MCS2, 99pc duty cycle)	X	5.15	67.59	16.91	0.00	150.0	± 9.6 %
		Y	5.11	67.36	16.68		150.0	
		Z	5.02	67.10	16.41		150.0	
10537-AAA	IEEE 802.11ac WiFi (40MHz, MCS3, 99pc duty cycle)	X	5.20	67.53	16.88	0.00	150.0	± 9.6 %
		Y	5.16	67.30	16.66		150.0	
		Z	5.07	67.07	16.40		150.0	
10538-AAA	IEEE 802.11ac WiFi (40MHz, MCS4, 99pc duty cycle)	X	5.27	67.48	16.89	0.00	150.0	± 9.6 %
		Y	5.23	67.27	16.67		150.0	
		Z	5.14	67.03	16.42		150.0	
10540-AAA	IEEE 802.11ac WiFi (40MHz, MCS6, 99pc duty cycle)	X	5.20	67.48	16.91	0.00	150.0	± 9.6 %
		Y	5.16	67.26	16.69		150.0	
		Z	5.07	67.00	16.42		150.0	

10541-AAA	IEEE 802.11ac WiFi (40MHz, MCS7, 99pc duty cycle)	X	5.18	67.34	16.82	0.00	150.0	± 9.6 %
		Y	5.14	67.12	16.61		150.0	
		Z	5.05	66.89	16.35		150.0	
10542-AAA	IEEE 802.11ac WiFi (40MHz, MCS8, 99pc duty cycle)	X	5.33	67.42	16.87	0.00	150.0	± 9.6 %
		Y	5.29	67.21	16.66		150.0	
		Z	5.20	66.99	16.41		150.0	
10543-AAA	IEEE 802.11ac WiFi (40MHz, MCS9, 99pc duty cycle)	X	5.40	67.44	16.90	0.00	150.0	± 9.6 %
		Y	5.36	67.24	16.70		150.0	
		Z	5.27	67.04	16.47		150.0	
10544-AAA	IEEE 802.11ac WiFi (80MHz, MCS0, 99pc duty cycle)	X	5.53	67.39	16.75	0.00	150.0	± 9.6 %
		Y	5.49	67.20	16.56		150.0	
		Z	5.41	66.99	16.32		150.0	
10545-AAA	IEEE 802.11ac WiFi (80MHz, MCS1, 99pc duty cycle)	X	5.74	67.91	16.97	0.00	150.0	± 9.6 %
		Y	5.70	67.70	16.77		150.0	
		Z	5.60	67.47	16.52		150.0	
10546-AAA	IEEE 802.11ac WiFi (80MHz, MCS2, 99pc duty cycle)	X	5.57	67.55	16.80	0.00	150.0	± 9.6 %
		Y	5.53	67.35	16.60		150.0	
		Z	5.45	67.13	16.36		150.0	
10547-AAA	IEEE 802.11ac WiFi (80MHz, MCS3, 99pc duty cycle)	X	5.66	67.65	16.84	0.00	150.0	± 9.6 %
		Y	5.62	67.45	16.64		150.0	
		Z	5.53	67.23	16.41		150.0	
10548-AAA	IEEE 802.11ac WiFi (80MHz, MCS4, 99pc duty cycle)	X	5.90	68.59	17.29	0.00	150.0	± 9.6 %
		Y	5.84	68.33	17.06		150.0	
		Z	5.71	67.98	16.76		150.0	
10550-AAA	IEEE 802.11ac WiFi (80MHz, MCS6, 99pc duty cycle)	X	5.64	67.75	16.92	0.00	150.0	± 9.6 %
		Y	5.60	67.54	16.71		150.0	
		Z	5.51	67.32	16.47		150.0	
10551-AAA	IEEE 802.11ac WiFi (80MHz, MCS7, 99pc duty cycle)	X	5.59	67.58	16.79	0.00	150.0	± 9.6 %
		Y	5.55	67.38	16.59		150.0	
		Z	5.45	67.11	16.33		150.0	
10552-AAA	IEEE 802.11ac WiFi (80MHz, MCS8, 99pc duty cycle)	X	5.54	67.49	16.75	0.00	150.0	± 9.6 %
		Y	5.50	67.29	16.55		150.0	
		Z	5.42	67.10	16.32		150.0	
10553-AAA	IEEE 802.11ac WiFi (80MHz, MCS9, 99pc duty cycle)	X	5.60	67.45	16.75	0.00	150.0	± 9.6 %
		Y	5.56	67.25	16.56		150.0	
		Z	5.48	67.05	16.33		150.0	
10554-AAB	IEEE 802.11ac WiFi (160MHz, MCS0, 99pc duty cycle)	X	5.95	67.70	16.80	0.00	150.0	± 9.6 %
		Y	5.91	67.51	16.61		150.0	
		Z	5.83	67.32	16.39		150.0	
10555-AAB	IEEE 802.11ac WiFi (160MHz, MCS1, 99pc duty cycle)	X	6.07	68.00	16.93	0.00	150.0	± 9.6 %
		Y	6.03	67.81	16.74		150.0	
		Z	5.94	67.58	16.50		150.0	
10556-AAB	IEEE 802.11ac WiFi (160MHz, MCS2, 99pc duty cycle)	X	6.11	68.10	16.97	0.00	150.0	± 9.6 %
		Y	6.07	67.90	16.78		150.0	
		Z	5.98	67.68	16.55		150.0	
10557-AAB	IEEE 802.11ac WiFi (160MHz, MCS3, 99pc duty cycle)	X	6.05	67.93	16.91	0.00	150.0	± 9.6 %
		Y	6.01	67.74	16.72		150.0	
		Z	5.92	67.53	16.49		150.0	

10558-AAB	IEEE 802.11ac WiFi (160MHz, MCS4, 99pc duty cycle)	X	6.09	68.07	16.99	0.00	150.0	± 9.6 %
		Y	6.04	67.87	16.80		150.0	
		Z	5.95	67.63	16.56		150.0	
10560-AAB	IEEE 802.11ac WiFi (160MHz, MCS6, 99pc duty cycle)	X	6.08	67.92	16.95	0.00	150.0	± 9.6 %
		Y	6.04	67.73	16.77		150.0	
		Z	5.95	67.52	16.54		150.0	
10561-AAB	IEEE 802.11ac WiFi (160MHz, MCS7, 99pc duty cycle)	X	6.02	67.94	17.00	0.00	150.0	± 9.6 %
		Y	5.98	67.74	16.81		150.0	
		Z	5.89	67.52	16.58		150.0	
10562-AAB	IEEE 802.11ac WiFi (160MHz, MCS8, 99pc duty cycle)	X	6.09	68.17	17.12	0.00	150.0	± 9.6 %
		Y	6.05	67.96	16.92		150.0	
		Z	5.95	67.72	16.67		150.0	
10563-AAB	IEEE 802.11ac WiFi (160MHz, MCS9, 99pc duty cycle)	X	6.19	68.10	17.04	0.00	150.0	± 9.6 %
		Y	6.15	67.90	16.85		150.0	
		Z	6.04	67.65	16.60		150.0	
10564-AAA	IEEE 802.11g WiFi 2.4 GHz (DSSS-OFDM, 9 Mbps, 99pc duty cycle)	X	4.91	67.89	17.17	0.46	150.0	± 9.6 %
		Y	4.87	67.64	16.93		150.0	
		Z	4.80	67.46	16.69		150.0	
10565-AAA	IEEE 802.11g WiFi 2.4 GHz (DSSS-OFDM, 12 Mbps, 99pc duty cycle)	X	5.11	68.27	17.46	0.46	150.0	± 9.6 %
		Y	5.08	68.05	17.23		150.0	
		Z	4.99	67.85	16.98		150.0	
10566-AAA	IEEE 802.11g WiFi 2.4 GHz (DSSS-OFDM, 18 Mbps, 99pc duty cycle)	X	4.96	68.15	17.30	0.46	150.0	± 9.6 %
		Y	4.92	67.91	17.06		150.0	
		Z	4.83	67.70	16.81		150.0	
10567-AAA	IEEE 802.11g WiFi 2.4 GHz (DSSS-OFDM, 24 Mbps, 99pc duty cycle)	X	4.99	68.55	17.66	0.46	150.0	± 9.6 %
		Y	4.96	68.34	17.45		150.0	
		Z	4.87	68.08	17.17		150.0	
10568-AAA	IEEE 802.11g WiFi 2.4 GHz (DSSS-OFDM, 36 Mbps, 99pc duty cycle)	X	4.88	67.99	17.11	0.46	150.0	± 9.6 %
		Y	4.83	67.70	16.84		150.0	
		Z	4.75	67.51	16.61		150.0	
10569-AAA	IEEE 802.11g WiFi 2.4 GHz (DSSS-OFDM, 48 Mbps, 99pc duty cycle)	X	4.98	68.78	17.81	0.46	150.0	± 9.6 %
		Y	4.95	68.58	17.60		150.0	
		Z	4.86	68.32	17.31		150.0	
10570-AAA	IEEE 802.11g WiFi 2.4 GHz (DSSS-OFDM, 54 Mbps, 99pc duty cycle)	X	4.98	68.56	17.69	0.46	150.0	± 9.6 %
		Y	4.95	68.33	17.47		150.0	
		Z	4.86	68.09	17.20		150.0	
10571-AAA	IEEE 802.11b WiFi 2.4 GHz (DSSS, 1 Mbps, 90pc duty cycle)	X	1.53	70.26	19.68	0.46	130.0	± 9.6 %
		Y	1.48	68.95	18.55		130.0	
		Z	1.37	67.40	17.39		130.0	
10572-AAA	IEEE 802.11b WiFi 2.4 GHz (DSSS, 2 Mbps, 90pc duty cycle)	X	1.59	71.46	20.33	0.46	130.0	± 9.6 %
		Y	1.53	70.00	19.13		130.0	
		Z	1.41	68.22	17.86		130.0	
10573-AAA	IEEE 802.11b WiFi 2.4 GHz (DSSS, 5.5 Mbps, 90pc duty cycle)	X	100.00	167.17	47.85	0.46	130.0	± 9.6 %
		Y	100.00	157.87	43.89		130.0	
		Z	100.00	153.13	41.71		130.0	
10574-AAA	IEEE 802.11b WiFi 2.4 GHz (DSSS, 11 Mbps, 90pc duty cycle)	X	3.10	89.83	28.24	0.46	130.0	± 9.6 %
		Y	2.51	83.93	25.32		130.0	
		Z	1.87	77.75	22.34		130.0	

10575-AAA	IEEE 802.11g WiFi 2.4 GHz (DSSS-OFDM, 6 Mbps, 90pc duty cycle)	X	4.72	67.77	17.29	0.46	130.0	± 9.6 %
		Y	4.68	67.55	17.05		130.0	
		Z	4.61	67.35	16.79		130.0	
10576-AAA	IEEE 802.11g WiFi 2.4 GHz (DSSS-OFDM, 9 Mbps, 90pc duty cycle)	X	4.75	67.98	17.37	0.46	130.0	± 9.6 %
		Y	4.72	67.76	17.14		130.0	
		Z	4.64	67.55	16.88		130.0	
10577-AAA	IEEE 802.11g WiFi 2.4 GHz (DSSS-OFDM, 12 Mbps, 90pc duty cycle)	X	4.92	68.19	17.49	0.46	130.0	± 9.6 %
		Y	4.89	67.98	17.27		130.0	
		Z	4.80	67.76	17.01		130.0	
10578-AAA	IEEE 802.11g WiFi 2.4 GHz (DSSS-OFDM, 18 Mbps, 90pc duty cycle)	X	4.83	68.39	17.63	0.46	130.0	± 9.6 %
		Y	4.80	68.19	17.41		130.0	
		Z	4.71	67.93	17.12		130.0	
10579-AAA	IEEE 802.11g WiFi 2.4 GHz (DSSS-OFDM, 24 Mbps, 90pc duty cycle)	X	4.60	67.68	16.96	0.46	130.0	± 9.6 %
		Y	4.56	67.40	16.68		130.0	
		Z	4.48	67.20	16.44		130.0	
10580-AAA	IEEE 802.11g WiFi 2.4 GHz (DSSS-OFDM, 36 Mbps, 90pc duty cycle)	X	4.64	67.76	17.00	0.46	130.0	± 9.6 %
		Y	4.60	67.47	16.71		130.0	
		Z	4.52	67.27	16.47		130.0	
10581-AAA	IEEE 802.11g WiFi 2.4 GHz (DSSS-OFDM, 48 Mbps, 90pc duty cycle)	X	4.75	68.54	17.65	0.46	130.0	± 9.6 %
		Y	4.72	68.32	17.42		130.0	
		Z	4.63	68.05	17.12		130.0	
10582-AAA	IEEE 802.11g WiFi 2.4 GHz (DSSS-OFDM, 54 Mbps, 90pc duty cycle)	X	4.53	67.47	16.77	0.46	130.0	± 9.6 %
		Y	4.49	67.15	16.46		130.0	
		Z	4.41	66.99	16.24		130.0	
10583-AAA	IEEE 802.11a/h WiFi 5 GHz (OFDM, 6 Mbps, 90pc duty cycle)	X	4.72	67.77	17.29	0.46	130.0	± 9.6 %
		Y	4.68	67.55	17.05		130.0	
		Z	4.61	67.35	16.79		130.0	
10584-AAA	IEEE 802.11a/h WiFi 5 GHz (OFDM, 9 Mbps, 90pc duty cycle)	X	4.75	67.98	17.37	0.46	130.0	± 9.6 %
		Y	4.72	67.76	17.14		130.0	
		Z	4.64	67.55	16.88		130.0	
10585-AAA	IEEE 802.11a/h WiFi 5 GHz (OFDM, 12 Mbps, 90pc duty cycle)	X	4.92	68.19	17.49	0.46	130.0	± 9.6 %
		Y	4.89	67.98	17.27		130.0	
		Z	4.80	67.76	17.01		130.0	
10586-AAA	IEEE 802.11a/h WiFi 5 GHz (OFDM, 18 Mbps, 90pc duty cycle)	X	4.83	68.39	17.63	0.46	130.0	± 9.6 %
		Y	4.80	68.19	17.41		130.0	
		Z	4.71	67.93	17.12		130.0	
10587-AAA	IEEE 802.11a/h WiFi 5 GHz (OFDM, 24 Mbps, 90pc duty cycle)	X	4.60	67.68	16.96	0.46	130.0	± 9.6 %
		Y	4.56	67.40	16.68		130.0	
		Z	4.48	67.20	16.44		130.0	
10588-AAA	IEEE 802.11a/h WiFi 5 GHz (OFDM, 36 Mbps, 90pc duty cycle)	X	4.64	67.76	17.00	0.46	130.0	± 9.6 %
		Y	4.60	67.47	16.71		130.0	
		Z	4.52	67.27	16.47		130.0	
10589-AAA	IEEE 802.11a/h WiFi 5 GHz (OFDM, 48 Mbps, 90pc duty cycle)	X	4.75	68.54	17.65	0.46	130.0	± 9.6 %
		Y	4.72	68.32	17.42		130.0	
		Z	4.63	68.05	17.12		130.0	
10590-AAA	IEEE 802.11a/h WiFi 5 GHz (OFDM, 54 Mbps, 90pc duty cycle)	X	4.53	67.47	16.77	0.46	130.0	± 9.6 %
		Y	4.49	67.15	16.46		130.0	
		Z	4.41	66.99	16.24		130.0	

10591-AAA	IEEE 802.11n (HT Mixed, 20MHz, MCS0, 90pc duty cycle)	X	4.86	67.77	17.35	0.46	130.0	± 9.6 %
		Y	4.83	67.57	17.13		130.0	
		Z	4.76	67.39	16.89		130.0	
10592-AAA	IEEE 802.11n (HT Mixed, 20MHz, MCS1, 90pc duty cycle)	X	5.00	68.10	17.48	0.46	130.0	± 9.6 %
		Y	4.97	67.89	17.26		130.0	
		Z	4.88	67.69	17.01		130.0	
10593-AAA	IEEE 802.11n (HT Mixed, 20MHz, MCS2, 90pc duty cycle)	X	4.92	68.01	17.36	0.46	130.0	± 9.6 %
		Y	4.89	67.79	17.13		130.0	
		Z	4.80	67.59	16.88		130.0	
10594-AAA	IEEE 802.11n (HT Mixed, 20MHz, MCS3, 90pc duty cycle)	X	4.97	68.18	17.52	0.46	130.0	± 9.6 %
		Y	4.94	67.97	17.30		130.0	
		Z	4.86	67.76	17.04		130.0	
10595-AAA	IEEE 802.11n (HT Mixed, 20MHz, MCS4, 90pc duty cycle)	X	4.95	68.18	17.45	0.46	130.0	± 9.6 %
		Y	4.91	67.96	17.21		130.0	
		Z	4.83	67.75	16.96		130.0	
10596-AAA	IEEE 802.11n (HT Mixed, 20MHz, MCS5, 90pc duty cycle)	X	4.88	68.19	17.46	0.46	130.0	± 9.6 %
		Y	4.85	67.95	17.22		130.0	
		Z	4.76	67.74	16.97		130.0	
10597-AAA	IEEE 802.11n (HT Mixed, 20MHz, MCS6, 90pc duty cycle)	X	4.83	68.07	17.33	0.46	130.0	± 9.6 %
		Y	4.80	67.83	17.08		130.0	
		Z	4.71	67.61	16.83		130.0	
10598-AAA	IEEE 802.11n (HT Mixed, 20MHz, MCS7, 90pc duty cycle)	X	4.82	68.29	17.59	0.46	130.0	± 9.6 %
		Y	4.79	68.08	17.36		130.0	
		Z	4.70	67.83	17.08		130.0	
10599-AAA	IEEE 802.11n (HT Mixed, 40MHz, MCS0, 90pc duty cycle)	X	5.54	68.17	17.50	0.46	130.0	± 9.6 %
		Y	5.51	67.99	17.30		130.0	
		Z	5.43	67.80	17.08		130.0	
10600-AAA	IEEE 802.11n (HT Mixed, 40MHz, MCS1, 90pc duty cycle)	X	5.69	68.70	17.74	0.46	130.0	± 9.6 %
		Y	5.65	68.47	17.52		130.0	
		Z	5.55	68.23	17.28		130.0	
10601-AAA	IEEE 802.11n (HT Mixed, 40MHz, MCS2, 90pc duty cycle)	X	5.56	68.37	17.60	0.46	130.0	± 9.6 %
		Y	5.53	68.17	17.39		130.0	
		Z	5.44	67.97	17.16		130.0	
10602-AAA	IEEE 802.11n (HT Mixed, 40MHz, MCS3, 90pc duty cycle)	X	5.70	68.54	17.60	0.46	130.0	± 9.6 %
		Y	5.66	68.33	17.38		130.0	
		Z	5.58	68.16	17.17		130.0	
10603-AAA	IEEE 802.11n (HT Mixed, 40MHz, MCS4, 90pc duty cycle)	X	5.78	68.87	17.89	0.46	130.0	± 9.6 %
		Y	5.75	68.67	17.69		130.0	
		Z	5.64	68.42	17.44		130.0	
10604-AAA	IEEE 802.11n (HT Mixed, 40MHz, MCS5, 90pc duty cycle)	X	5.65	68.51	17.70	0.46	130.0	± 9.6 %
		Y	5.62	68.31	17.49		130.0	
		Z	5.52	68.06	17.24		130.0	
10605-AAA	IEEE 802.11n (HT Mixed, 40MHz, MCS6, 90pc duty cycle)	X	5.67	68.56	17.73	0.46	130.0	± 9.6 %
		Y	5.64	68.34	17.50		130.0	
		Z	5.54	68.11	17.26		130.0	
10606-AAA	IEEE 802.11n (HT Mixed, 40MHz, MCS7, 90pc duty cycle)	X	5.41	67.85	17.23	0.46	130.0	± 9.6 %
		Y	5.38	67.63	17.01		130.0	
		Z	5.31	67.50	16.82		130.0	

10607-AAA	IEEE 802.11ac WiFi (20MHz, MCS0, 90pc duty cycle)	X	4.73	67.22	17.05	0.46	130.0	± 9.6 %
		Y	4.69	66.99	16.81		130.0	
		Z	4.61	66.77	16.55		130.0	
10608-AAA	IEEE 802.11ac WiFi (20MHz, MCS1, 90pc duty cycle)	X	4.89	67.59	17.21	0.46	130.0	± 9.6 %
		Y	4.85	67.36	16.97		130.0	
		Z	4.76	67.12	16.70		130.0	
10609-AAA	IEEE 802.11ac WiFi (20MHz, MCS2, 90pc duty cycle)	X	4.79	67.47	17.06	0.46	130.0	± 9.6 %
		Y	4.75	67.21	16.81		130.0	
		Z	4.66	66.98	16.54		130.0	
10610-AAA	IEEE 802.11ac WiFi (20MHz, MCS3, 90pc duty cycle)	X	4.84	67.62	17.21	0.46	130.0	± 9.6 %
		Y	4.80	67.38	16.98		130.0	
		Z	4.71	67.13	16.70		130.0	
10611-AAA	IEEE 802.11ac WiFi (20MHz, MCS4, 90pc duty cycle)	X	4.75	67.43	17.07	0.46	130.0	± 9.6 %
		Y	4.71	67.19	16.83		130.0	
		Z	4.62	66.94	16.55		130.0	
10612-AAA	IEEE 802.11ac WiFi (20MHz, MCS5, 90pc duty cycle)	X	4.76	67.63	17.15	0.46	130.0	± 9.6 %
		Y	4.72	67.36	16.89		130.0	
		Z	4.62	67.11	16.61		130.0	
10613-AAA	IEEE 802.11ac WiFi (20MHz, MCS6, 90pc duty cycle)	X	4.76	67.45	16.99	0.46	130.0	± 9.6 %
		Y	4.71	67.17	16.73		130.0	
		Z	4.62	66.92	16.46		130.0	
10614-AAA	IEEE 802.11ac WiFi (20MHz, MCS7, 90pc duty cycle)	X	4.71	67.65	17.23	0.46	130.0	± 9.6 %
		Y	4.68	67.41	16.99		130.0	
		Z	4.58	67.13	16.69		130.0	
10615-AAA	IEEE 802.11ac WiFi (20MHz, MCS8, 90pc duty cycle)	X	4.75	67.29	16.86	0.46	130.0	± 9.6 %
		Y	4.71	67.01	16.59		130.0	
		Z	4.62	66.80	16.34		130.0	
10616-AAA	IEEE 802.11ac WiFi (40MHz, MCS0, 90pc duty cycle)	X	5.36	67.41	17.11	0.46	130.0	± 9.6 %
		Y	5.32	67.22	16.91		130.0	
		Z	5.24	67.01	16.67		130.0	
10617-AAA	IEEE 802.11ac WiFi (40MHz, MCS1, 90pc duty cycle)	X	5.44	67.66	17.21	0.46	130.0	± 9.6 %
		Y	5.40	67.45	17.00		130.0	
		Z	5.30	67.20	16.74		130.0	
10618-AAA	IEEE 802.11ac WiFi (40MHz, MCS2, 90pc duty cycle)	X	5.34	67.71	17.26	0.46	130.0	± 9.6 %
		Y	5.30	67.51	17.04		130.0	
		Z	5.21	67.26	16.79		130.0	
10619-AAA	IEEE 802.11ac WiFi (40MHz, MCS3, 90pc duty cycle)	X	5.34	67.48	17.07	0.46	130.0	± 9.6 %
		Y	5.30	67.27	16.86		130.0	
		Z	5.22	67.06	16.62		130.0	
10620-AAA	IEEE 802.11ac WiFi (40MHz, MCS4, 90pc duty cycle)	X	5.41	67.47	17.11	0.46	130.0	± 9.6 %
		Y	5.38	67.26	16.90		130.0	
		Z	5.29	67.06	16.67		130.0	
10621-AAA	IEEE 802.11ac WiFi (40MHz, MCS5, 90pc duty cycle)	X	5.41	67.55	17.27	0.46	130.0	± 9.6 %
		Y	5.38	67.38	17.08		130.0	
		Z	5.29	67.14	16.82		130.0	
10622-AAA	IEEE 802.11ac WiFi (40MHz, MCS6, 90pc duty cycle)	X	5.42	67.70	17.34	0.46	130.0	± 9.6 %
		Y	5.38	67.50	17.14		130.0	
		Z	5.29	67.26	16.88		130.0	

10623-AAA	IEEE 802.11ac WiFi (40MHz, MCS7, 90pc duty cycle)	X	5.29	67.21	16.97	0.46	130.0	± 9.6 %
		Y	5.26	67.01	16.75		130.0	
		Z	5.17	66.80	16.52		130.0	
10624-AAA	IEEE 802.11ac WiFi (40MHz, MCS8, 90pc duty cycle)	X	5.49	67.44	17.13	0.46	130.0	± 9.6 %
		Y	5.46	67.25	16.93		130.0	
		Z	5.37	67.04	16.70		130.0	
10625-AAA	IEEE 802.11ac WiFi (40MHz, MCS9, 90pc duty cycle)	X	5.67	67.85	17.40	0.46	130.0	± 9.6 %
		Y	5.63	67.64	17.18		130.0	
		Z	5.49	67.29	16.88		130.0	
10626-AAA	IEEE 802.11ac WiFi (80MHz, MCS0, 90pc duty cycle)	X	5.67	67.37	17.01	0.46	130.0	± 9.6 %
		Y	5.64	67.20	16.82		130.0	
		Z	5.56	67.01	16.60		130.0	
10627-AAA	IEEE 802.11ac WiFi (80MHz, MCS1, 90pc duty cycle)	X	5.95	68.11	17.34	0.46	130.0	± 9.6 %
		Y	5.91	67.91	17.14		130.0	
		Z	5.81	67.67	16.90		130.0	
10628-AAA	IEEE 802.11ac WiFi (80MHz, MCS2, 90pc duty cycle)	X	5.68	67.42	16.93	0.46	130.0	± 9.6 %
		Y	5.65	67.22	16.73		130.0	
		Z	5.56	67.03	16.51		130.0	
10629-AAA	IEEE 802.11ac WiFi (80MHz, MCS3, 90pc duty cycle)	X	5.78	67.58	17.01	0.46	130.0	± 9.6 %
		Y	5.75	67.38	16.80		130.0	
		Z	5.66	67.19	16.59		130.0	
10630-AAA	IEEE 802.11ac WiFi (80MHz, MCS4, 90pc duty cycle)	X	6.18	69.00	17.72	0.46	130.0	± 9.6 %
		Y	6.12	68.72	17.47		130.0	
		Z	5.97	68.32	17.16		130.0	
10631-AAA	IEEE 802.11ac WiFi (80MHz, MCS5, 90pc duty cycle)	X	6.05	68.69	17.74	0.46	130.0	± 9.6 %
		Y	6.02	68.51	17.56		130.0	
		Z	5.90	68.19	17.27		130.0	
10632-AAA	IEEE 802.11ac WiFi (80MHz, MCS6, 90pc duty cycle)	X	5.92	68.20	17.52	0.46	130.0	± 9.6 %
		Y	5.89	68.03	17.34		130.0	
		Z	5.79	67.79	17.09		130.0	
10633-AAA	IEEE 802.11ac WiFi (80MHz, MCS7, 90pc duty cycle)	X	5.75	67.61	17.06	0.46	130.0	± 9.6 %
		Y	5.71	67.43	16.87		130.0	
		Z	5.61	67.18	16.62		130.0	
10634-AAA	IEEE 802.11ac WiFi (80MHz, MCS8, 90pc duty cycle)	X	5.73	67.62	17.12	0.46	130.0	± 9.6 %
		Y	5.70	67.45	16.93		130.0	
		Z	5.61	67.26	16.71		130.0	
10635-AAA	IEEE 802.11ac WiFi (80MHz, MCS9, 90pc duty cycle)	X	5.59	66.93	16.52	0.46	130.0	± 9.6 %
		Y	5.55	66.70	16.29		130.0	
		Z	5.48	66.56	16.11		130.0	
10636-AAB	IEEE 802.11ac WiFi (160MHz, MCS0, 90pc duty cycle)	X	6.10	67.70	17.06	0.46	130.0	± 9.6 %
		Y	6.07	67.53	16.88		130.0	
		Z	5.99	67.35	16.67		130.0	
10637-AAB	IEEE 802.11ac WiFi (160MHz, MCS1, 90pc duty cycle)	X	6.26	68.11	17.25	0.46	130.0	± 9.6 %
		Y	6.22	67.93	17.06		130.0	
		Z	6.13	67.70	16.83		130.0	
10638-AAB	IEEE 802.11ac WiFi (160MHz, MCS2, 90pc duty cycle)	X	6.27	68.11	17.23	0.46	130.0	± 9.6 %
		Y	6.23	67.92	17.04		130.0	
		Z	6.14	67.72	16.82		130.0	

10639-AAB	IEEE 802.11ac WiFi (160MHz, MCS3, 90pc duty cycle)	X	6.22	67.97	17.20	0.46	130.0	± 9.6 %
		Y	6.18	67.80	17.02		130.0	
		Z	6.10	67.60	16.80		130.0	
10640-AAB	IEEE 802.11ac WiFi (160MHz, MCS4, 90pc duty cycle)	X	6.21	67.98	17.15	0.46	130.0	± 9.6 %
		Y	6.17	67.78	16.95		130.0	
		Z	6.08	67.56	16.73		130.0	
10641-AAB	IEEE 802.11ac WiFi (160MHz, MCS5, 90pc duty cycle)	X	6.30	68.00	17.18	0.46	130.0	± 9.6 %
		Y	6.26	67.81	16.98		130.0	
		Z	6.17	67.61	16.77		130.0	
10642-AAB	IEEE 802.11ac WiFi (160MHz, MCS6, 90pc duty cycle)	X	6.30	68.13	17.40	0.46	130.0	± 9.6 %
		Y	6.27	67.97	17.23		130.0	
		Z	6.18	67.76	17.01		130.0	
10643-AAB	IEEE 802.11ac WiFi (160MHz, MCS7, 90pc duty cycle)	X	6.16	67.91	17.20	0.46	130.0	± 9.6 %
		Y	6.12	67.71	17.00		130.0	
		Z	6.03	67.50	16.78		130.0	
10644-AAB	IEEE 802.11ac WiFi (160MHz, MCS8, 90pc duty cycle)	X	6.24	68.16	17.34	0.46	130.0	± 9.6 %
		Y	6.20	67.95	17.14		130.0	
		Z	6.10	67.72	16.91		130.0	
10645-AAB	IEEE 802.11ac WiFi (160MHz, MCS9, 90pc duty cycle)	X	6.44	68.39	17.42	0.46	130.0	± 9.6 %
		Y	6.39	68.17	17.21		130.0	
		Z	6.27	67.87	16.95		130.0	
10646-AAD	LTE-TDD (SC-FDMA, 1 RB, 5 MHz, QPSK, UL Subframe=2,7)	X	100.00	154.07	50.96	9.30	60.0	± 9.6 %
		Y	100.00	149.19	48.64		60.0	
		Z	100.00	151.77	49.64		60.0	
10647-AAC	LTE-TDD (SC-FDMA, 1 RB, 20 MHz, QPSK, UL Subframe=2,7)	X	100.00	155.63	51.65	9.30	60.0	± 9.6 %
		Y	100.00	150.58	49.25		60.0	
		Z	100.00	153.26	50.29		60.0	
10648-AAA	CDMA2000 (1x Advanced)	X	7.29	96.44	23.44	0.00	150.0	± 9.6 %
		Y	1.15	71.60	14.63		150.0	
		Z	0.73	65.79	11.39		150.0	
10652-AAB	LTE-TDD (OFDMA, 5 MHz, E-TM 3.1, Clipping 44%)	X	4.70	71.99	19.13	2.23	80.0	± 9.6 %
		Y	4.65	71.36	18.64		80.0	
		Z	4.32	70.31	17.98		80.0	
10653-AAB	LTE-TDD (OFDMA, 10 MHz, E-TM 3.1, Clipping 44%)	X	4.86	69.58	18.56	2.23	80.0	± 9.6 %
		Y	4.87	69.28	18.24		80.0	
		Z	4.66	68.67	17.81		80.0	
10654-AAB	LTE-TDD (OFDMA, 15 MHz, E-TM 3.1, Clipping 44%)	X	4.78	68.93	18.47	2.23	80.0	± 9.6 %
		Y	4.81	68.69	18.18		80.0	
		Z	4.62	68.14	17.78		80.0	
10655-AAB	LTE-TDD (OFDMA, 20 MHz, E-TM 3.1, Clipping 44%)	X	4.83	68.76	18.45	2.23	80.0	± 9.6 %
		Y	4.86	68.54	18.16		80.0	
		Z	4.67	68.01	17.79		80.0	

^E Uncertainty is determined using the max. deviation from linear response applying rectangular distribution and is expressed for the square of the field value.



Accredited by the Swiss Accreditation Service (SAS)
The Swiss Accreditation Service is one of the signatories to the EA
Multilateral Agreement for the recognition of calibration certificates

Accreditation No.: **SCS 0108**

Client **PC Test**

Certificate No: **ES3-3347_Nov17**

CALIBRATION CERTIFICATE

Object **ES3DV3 - SN:3347**

Calibration procedure(s) **QA CAL-01.v9, QA CAL-23.v5, QA CAL-25.v6
Calibration procedure for dosimetric E-field probes**

Calibration date: **November 14, 2017**

*BN ✓
11/3/2018*

This calibration certificate documents the traceability to national standards, which realize the physical units of measurements (SI).
The measurements and the uncertainties with confidence probability are given on the following pages and are part of the certificate.

All calibrations have been conducted in the closed laboratory facility: environment temperature (22 ± 3)°C and humidity < 70%.

Calibration Equipment used (M&TE critical for calibration)

Primary Standards	ID	Cal Date (Certificate No.)	Scheduled Calibration
Power meter NRP	SN: 104778	04-Apr-17 (No. 217-02521/02522)	Apr-18
Power sensor NRP-Z91	SN: 103244	04-Apr-17 (No. 217-02521)	Apr-18
Power sensor NRP-Z91	SN: 103245	04-Apr-17 (No. 217-02525)	Apr-18
Reference 20 dB Attenuator	SN: S5277 (20x)	07-Apr-17 (No. 217-02528)	Apr-18
Reference Probe ES3DV2	SN: 3013	31-Dec-16 (No. ES3-3013_Dec16)	Dec-17
DAE4	SN: 660	7-Dec-16 (No. DAE4-660_Dec16)	Dec-17
Secondary Standards	ID	Check Date (in house)	Scheduled Check
Power meter E4419B	SN: GB41293874	06-Apr-16 (in house check Jun-16)	In house check: Jun-18
Power sensor E4412A	SN: MY41498087	06-Apr-16 (in house check Jun-16)	In house check: Jun-18
Power sensor E4412A	SN: 000110210	06-Apr-16 (in house check Jun-16)	In house check: Jun-18
RF generator HP 8648C	SN: US3642U01700	04-Aug-99 (in house check Jun-16)	In house check: Jun-18
Network Analyzer HP 8753E	SN: US37390585	18-Oct-01 (in house check Oct-17)	In house check: Oct-18

Calibrated by:	Name Leif Klysner	Function Laboratory Technician	Signature
Approved by:	Name Katja Pokovic	Function Technical Manager	Signature

Issued: November 15, 2017

This calibration certificate shall not be reproduced except in full without written approval of the laboratory.



Accredited by the Swiss Accreditation Service (SAS)
 The Swiss Accreditation Service is one of the signatories to the EA
 Multilateral Agreement for the recognition of calibration certificates

Accreditation No.: **SCS 0108**

Glossary:

TSL	tissue simulating liquid
NORM _{x,y,z}	sensitivity in free space
ConvF	sensitivity in TSL / NORM _{x,y,z}
DCP	diode compression point
CF	crest factor (1/duty_cycle) of the RF signal
A, B, C, D	modulation dependent linearization parameters
Polarization φ	φ rotation around probe axis
Polarization §	§ rotation around an axis that is in the plane normal to probe axis (at measurement center), i.e., § = 0 is normal to probe axis
Connector Angle	information used in DASY system to align probe sensor X to the robot coordinate system

Calibration is Performed According to the Following Standards:

- a) IEEE Std 1528-2013, "IEEE Recommended Practice for Determining the Peak Spatial-Averaged Specific Absorption Rate (SAR) in the Human Head from Wireless Communications Devices: Measurement Techniques", June 2013
- b) IEC 62209-1, "Measurement procedure for the assessment of Specific Absorption Rate (SAR) from hand-held and body-mounted devices used next to the ear (frequency range of 300 MHz to 6 GHz)", July 2016
- c) IEC 62209-2, "Procedure to determine the Specific Absorption Rate (SAR) for wireless communication devices used in close proximity to the human body (frequency range of 30 MHz to 6 GHz)", March 2010
- d) KDB 865664, "SAR Measurement Requirements for 100 MHz to 6 GHz"

Methods Applied and Interpretation of Parameters:

- **NORM_{x,y,z}**: Assessed for E-field polarization § = 0 (f ≤ 900 MHz in TEM-cell; f > 1800 MHz: R22 waveguide). NORM_{x,y,z} are only intermediate values, i.e., the uncertainties of NORM_{x,y,z} does not affect the E²-field uncertainty inside TSL (see below ConvF).
- **NORM(f)_{x,y,z} = NORM_{x,y,z} * frequency_response** (see Frequency Response Chart). This linearization is implemented in DASY4 software versions later than 4.2. The uncertainty of the frequency response is included in the stated uncertainty of ConvF.
- **DCP_{x,y,z}**: DCP are numerical linearization parameters assessed based on the data of power sweep with CW signal (no uncertainty required). DCP does not depend on frequency nor media.
- **PAR**: PAR is the Peak to Average Ratio that is not calibrated but determined based on the signal characteristics
- **A_{x,y,z}; B_{x,y,z}; C_{x,y,z}; D_{x,y,z}; VR_{x,y,z}; A, B, C, D** are numerical linearization parameters assessed based on the data of power sweep for specific modulation signal. The parameters do not depend on frequency nor media. VR is the maximum calibration range expressed in RMS voltage across the diode.
- **ConvF and Boundary Effect Parameters**: Assessed in flat phantom using E-field (or Temperature Transfer Standard for f ≤ 800 MHz) and inside waveguide using analytical field distributions based on power measurements for f > 800 MHz. The same setups are used for assessment of the parameters applied for boundary compensation (alpha, depth) of which typical uncertainty values are given. These parameters are used in DASY4 software to improve probe accuracy close to the boundary. The sensitivity in TSL corresponds to NORM_{x,y,z} * ConvF whereby the uncertainty corresponds to that given for ConvF. A frequency dependent ConvF is used in DASY version 4.4 and higher which allows extending the validity from ± 50 MHz to ± 100 MHz.
- **Spherical isotropy (3D deviation from isotropy)**: in a field of low gradients realized using a flat phantom exposed by a patch antenna.
- **Sensor Offset**: The sensor offset corresponds to the offset of virtual measurement center from the probe tip (on probe axis). No tolerance required.
- **Connector Angle**: The angle is assessed using the information gained by determining the NORM_x (no uncertainty required).

Probe ES3DV3

SN:3347

Manufactured: March 15, 2012
Calibrated: November 14, 2017

Calibrated for DASY/EASY Systems
(Note: non-compatible with DASY2 system!)

DASY/EASY - Parameters of Probe: ES3DV3 - SN:3347

Basic Calibration Parameters

	Sensor X	Sensor Y	Sensor Z	Unc (k=2)
Norm ($\mu\text{V}/(\text{V}/\text{m})^2$) ^A	1.16	1.35	1.21	$\pm 10.1\%$
DCP (mV) ^B	101.8	103.3	100.6	

Modulation Calibration Parameters

UID	Communication System Name		A dB	B dB $\sqrt{\mu\text{V}}$	C	D dB	VR mV	Unc ^E (k=2)
0	CW	X	0.0	0.0	1.0	0.00	180.3	$\pm 3.5\%$
		Y	0.0	0.0	1.0		184.2	
		Z	0.0	0.0	1.0		182.7	

Note: For details on UID parameters see Appendix.

Sensor Model Parameters

	C1 fF	C2 fF	α V^{-1}	T1 $\text{ms}\cdot\text{V}^{-2}$	T2 $\text{ms}\cdot\text{V}^{-1}$	T3 ms	T4 V^{-2}	T5 V^{-1}	T6
X	56.85	405.7	35.26	28.78	2.146	5.1	1.078	0.389	1.015
Y	53.71	386.4	35.65	28.84	2.390	5.1	0.960	0.434	1.014
Z	52.49	373.6	35.24	27.58	1.840	5.1	0.845	0.389	1.013

The reported uncertainty of measurement is stated as the standard uncertainty of measurement multiplied by the coverage factor $k=2$, which for a normal distribution corresponds to a coverage probability of approximately 95%.

^A The uncertainties of Norm X,Y,Z do not affect the E^2 -field uncertainty inside TSL (see Pages 5 and 6).

^B Numerical linearization parameter: uncertainty not required.

^E Uncertainty is determined using the max. deviation from linear response applying rectangular distribution and is expressed for the square of the field value.

DASY/EASY - Parameters of Probe: ES3DV3 - SN:3347

Calibration Parameter Determined in Head Tissue Simulating Media

f (MHz) ^C	Relative Permittivity ^F	Conductivity (S/m) ^F	ConvF X	ConvF Y	ConvF Z	Alpha ^G	Depth ^G (mm)	Unc (k=2)
750	41.9	0.89	6.65	6.65	6.65	0.61	1.33	± 12.0 %
835	41.5	0.90	6.36	6.36	6.36	0.57	1.33	± 12.0 %
1750	40.1	1.37	5.48	5.48	5.48	0.59	1.33	± 12.0 %
1900	40.0	1.40	5.24	5.24	5.24	0.57	1.40	± 12.0 %
2300	39.5	1.67	4.94	4.94	4.94	0.57	1.44	± 12.0 %
2450	39.2	1.80	4.64	4.64	4.64	0.67	1.40	± 12.0 %
2600	39.0	1.96	4.47	4.47	4.47	0.80	1.31	± 12.0 %

^C Frequency validity above 300 MHz of ± 100 MHz only applies for DASY v4.4 and higher (see Page 2), else it is restricted to ± 50 MHz. The uncertainty is the RSS of the ConvF uncertainty at calibration frequency and the uncertainty for the indicated frequency band. Frequency validity below 300 MHz is ± 10, 25, 40, 50 and 70 MHz for ConvF assessments at 30, 64, 128, 150 and 220 MHz respectively. Above 5 GHz frequency validity can be extended to ± 110 MHz.

^F At frequencies below 3 GHz, the validity of tissue parameters (ϵ and σ) can be relaxed to ± 10% if liquid compensation formula is applied to measured SAR values. At frequencies above 3 GHz, the validity of tissue parameters (ϵ and σ) is restricted to ± 5%. The uncertainty is the RSS of the ConvF uncertainty for indicated target tissue parameters.

^G Alpha/Depth are determined during calibration. SPEAG warrants that the remaining deviation due to the boundary effect after compensation is always less than ± 1% for frequencies below 3 GHz and below ± 2% for frequencies between 3-6 GHz at any distance larger than half the probe tip diameter from the boundary.

DASY/EASY - Parameters of Probe: ES3DV3 - SN:3347

Calibration Parameter Determined in Body Tissue Simulating Media

f (MHz) ^C	Relative Permittivity ^F	Conductivity (S/m) ^F	ConvF X	ConvF Y	ConvF Z	Alpha ^G	Depth ^G (mm)	Unc (k=2)
750	55.5	0.96	6.45	6.45	6.45	0.47	1.56	± 12.0 %
835	55.2	0.97	6.29	6.29	6.29	0.66	1.29	± 12.0 %
1750	53.4	1.49	5.15	5.15	5.15	0.68	1.33	± 12.0 %
1900	53.3	1.52	4.93	4.93	4.93	0.59	1.42	± 12.0 %
2300	52.9	1.81	4.71	4.71	4.71	0.80	1.27	± 12.0 %
2450	52.7	1.95	4.53	4.53	4.53	0.75	1.25	± 12.0 %
2600	52.5	2.16	4.35	4.35	4.35	0.80	1.25	± 12.0 %

^C Frequency validity above 300 MHz of ± 100 MHz only applies for DASY v4.4 and higher (see Page 2), else it is restricted to ± 50 MHz. The uncertainty is the RSS of the ConvF uncertainty at calibration frequency and the uncertainty for the indicated frequency band. Frequency validity below 300 MHz is ± 10, 25, 40, 50 and 70 MHz for ConvF assessments at 30, 64, 128, 150 and 220 MHz respectively. Above 5 GHz frequency validity can be extended to ± 110 MHz.

^F At frequencies below 3 GHz, the validity of tissue parameters (ϵ and σ) can be relaxed to ± 10% if liquid compensation formula is applied to measured SAR values. At frequencies above 3 GHz, the validity of tissue parameters (ϵ and σ) is restricted to ± 5%. The uncertainty is the RSS of the ConvF uncertainty for indicated target tissue parameters.

^G Alpha/Depth are determined during calibration. SPEAG warrants that the remaining deviation due to the boundary effect after compensation is always less than ± 1% for frequencies below 3 GHz and below ± 2% for frequencies between 3-6 GHz at any distance larger than half the probe tip diameter from the boundary.

Frequency Response of E-Field

(TEM-Cell:ifi110 EXX, Waveguide: R22)

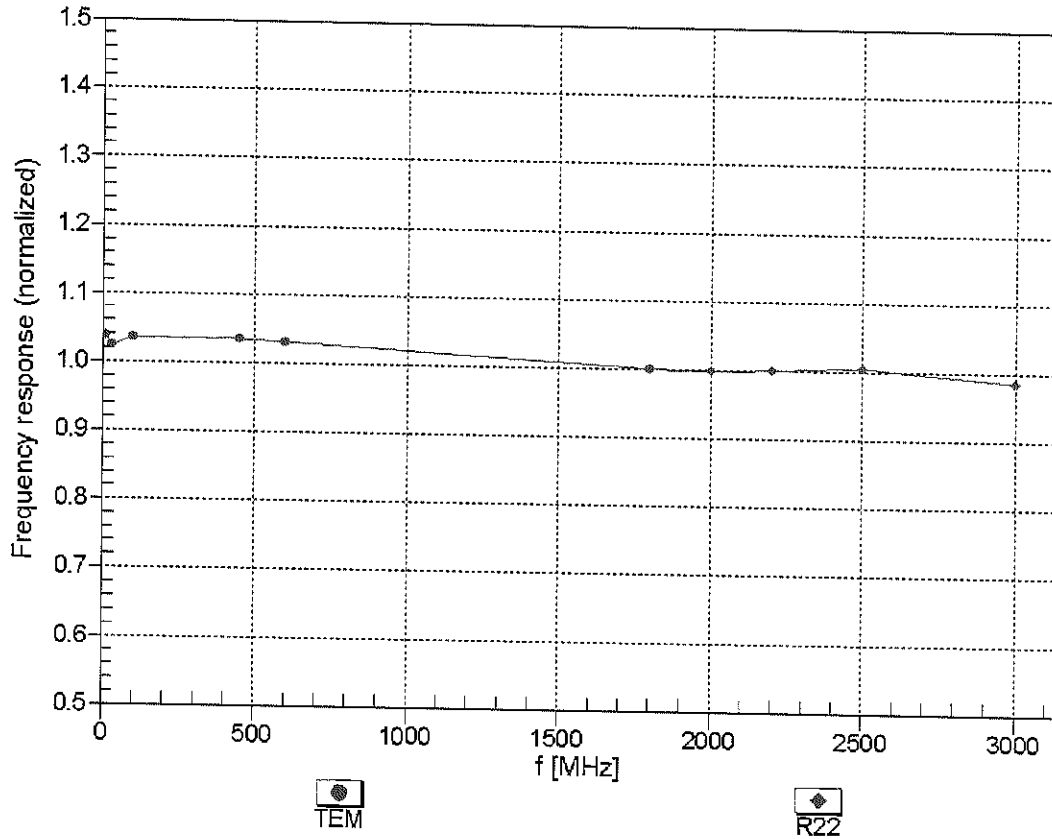

Uncertainty of Frequency Response of E-field: $\pm 6.3\%$ ($k=2$)

Receiving Pattern (ϕ), $\theta = 0^\circ$

f=600 MHz,TEM

f=1800 MHz,R22

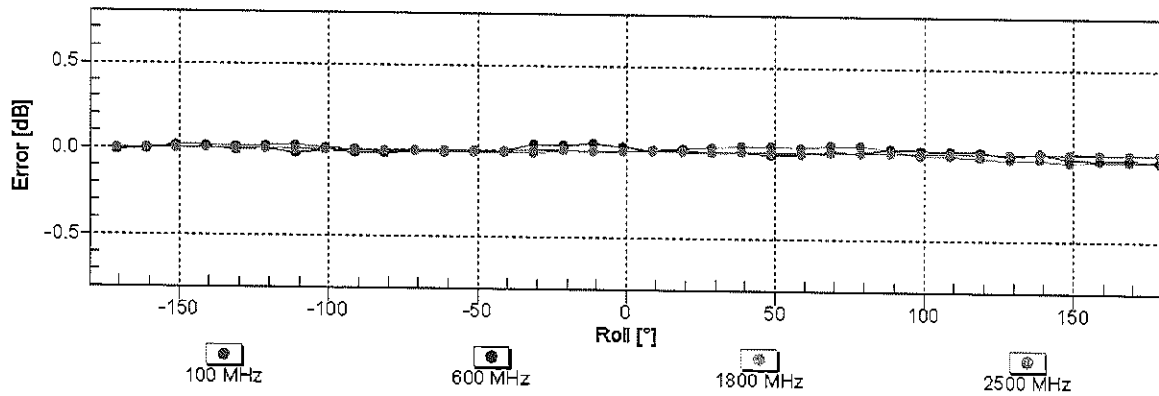
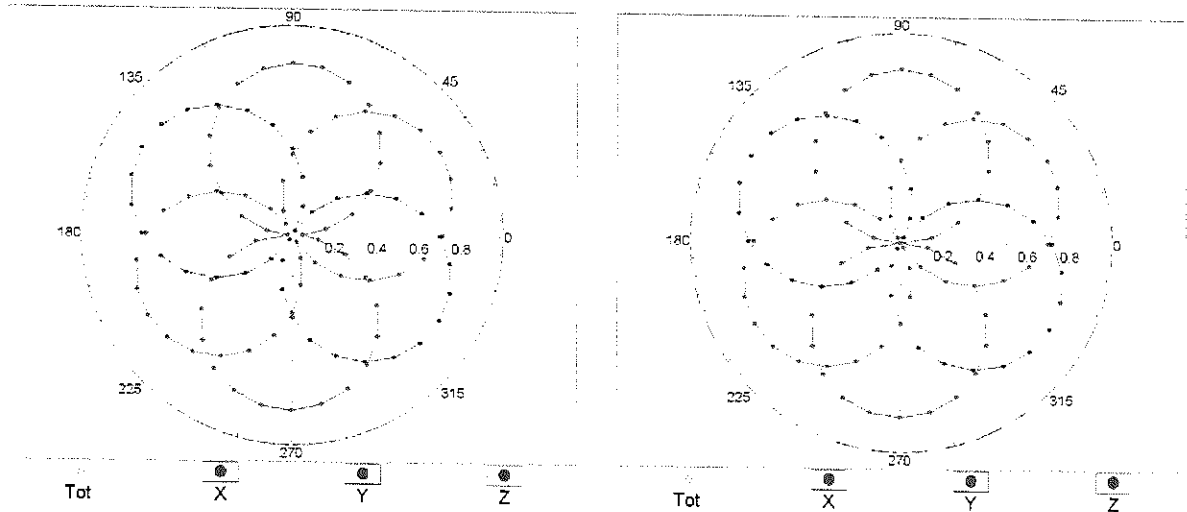

Uncertainty of Axial Isotropy Assessment: $\pm 0.5\%$ (k=2)

Dynamic Range f(SAR_{head})

(TEM cell , f_{eval}= 1900 MHz)

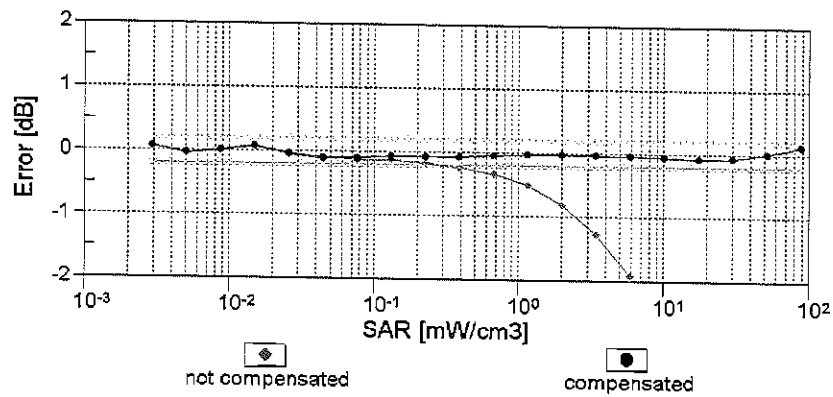
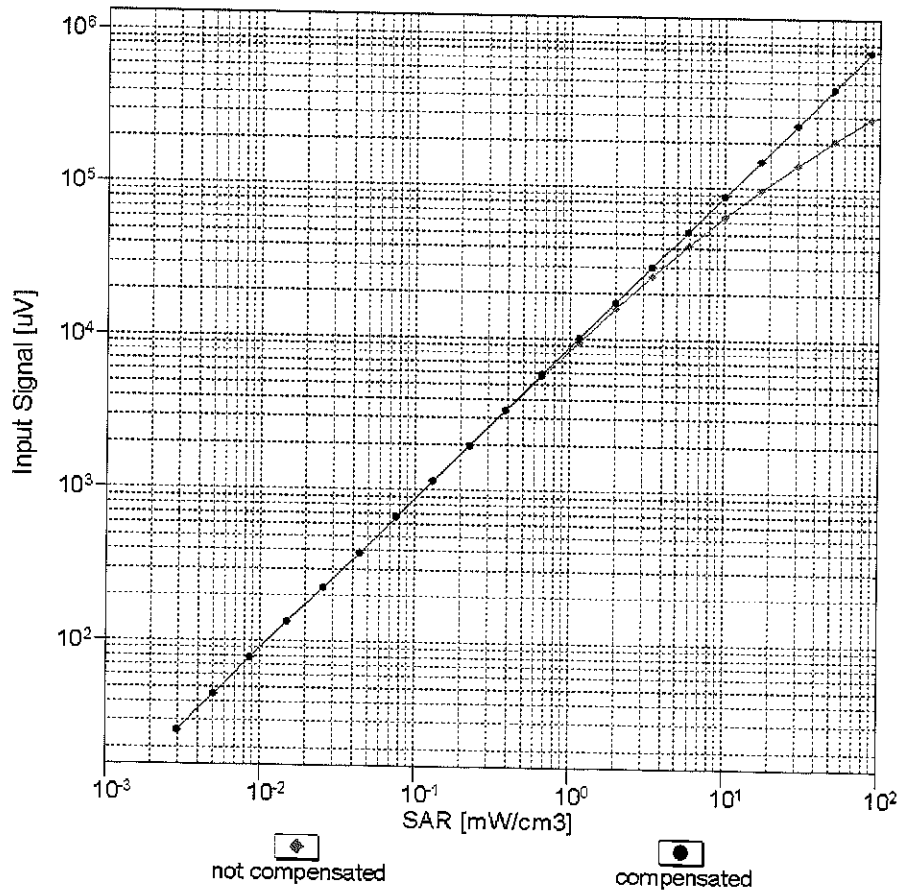

Uncertainty of Linearity Assessment: ± 0.6% (k=2)

Conversion Factor Assessment

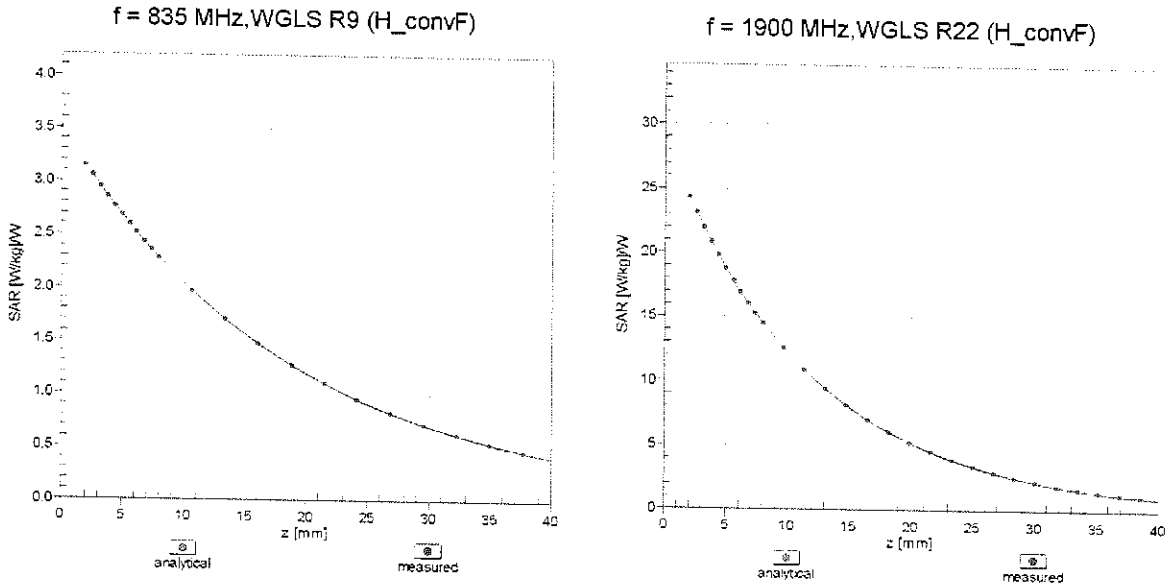

Deviation from Isotropy in Liquid Error (ϕ, θ), f = 900 MHz

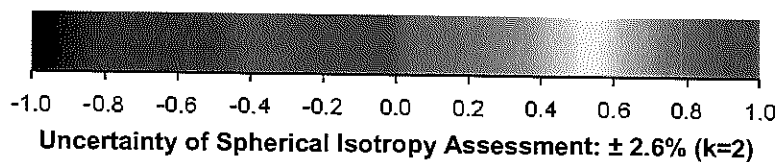
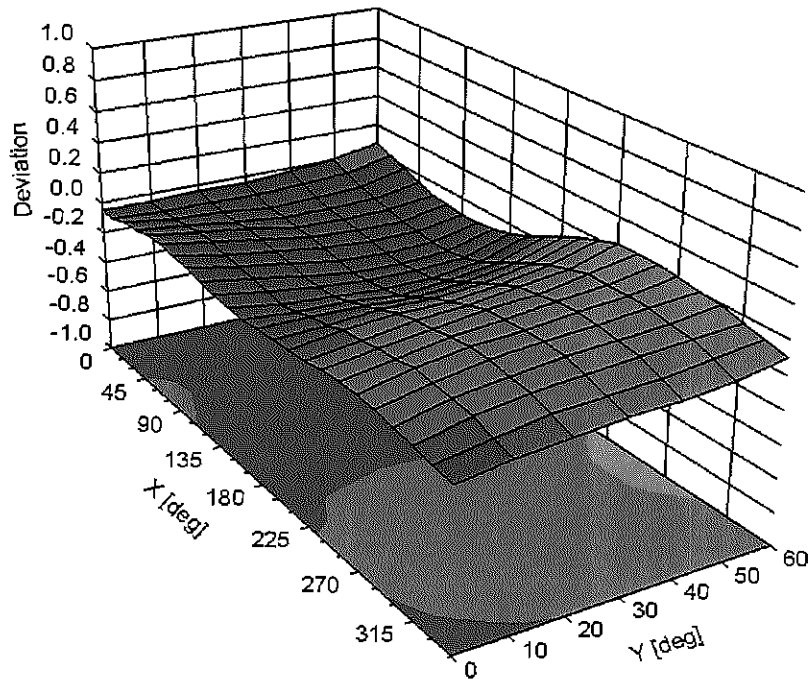

Uncertainty of Spherical Isotropy Assessment: $\pm 2.6\%$ (k=2)

DASY/EASY - Parameters of Probe: ES3DV3 - SN:3347

Other Probe Parameters

Sensor Arrangement	Triangular
Connector Angle (°)	-31.2
Mechanical Surface Detection Mode	enabled
Optical Surface Detection Mode	disabled
Probe Overall Length	337 mm
Probe Body Diameter	10 mm
Tip Length	10 mm
Tip Diameter	4 mm
Probe Tip to Sensor X Calibration Point	2 mm
Probe Tip to Sensor Y Calibration Point	2 mm
Probe Tip to Sensor Z Calibration Point	2 mm
Recommended Measurement Distance from Surface	3 mm

Appendix: Modulation Calibration Parameters

UID	Communication System Name		A dB	B dB $\sqrt{\mu V}$	C	D dB	VR mV	Max Unc ^E (k=2)
0	CW	X	0.00	0.00	1.00	0.00	180.3	$\pm 3.5\%$
		Y	0.00	0.00	1.00		184.2	
		Z	0.00	0.00	1.00		182.7	
10010- CAA	SAR Validation (Square, 100ms, 10ms)	X	10.13	82.41	19.62	10.00	25.0	$\pm 9.6\%$
		Y	9.84	82.02	19.71		25.0	
		Z	14.66	87.98	21.30		25.0	
10011- CAB	UMTS-FDD (WCDMA)	X	1.40	73.24	18.56	0.00	150.0	$\pm 9.6\%$
		Y	1.15	69.55	16.47		150.0	
		Z	1.95	80.03	22.00		150.0	
10012- CAB	IEEE 802.11b WiFi 2.4 GHz (DSSS, 1 Mbps)	X	1.36	66.66	17.13	0.41	150.0	$\pm 9.6\%$
		Y	1.31	65.74	16.36		150.0	
		Z	1.42	68.00	18.26		150.0	
10013- CAB	IEEE 802.11g WiFi 2.4 GHz (DSSS-OFDM, 6 Mbps)	X	5.14	67.48	17.69	1.46	150.0	$\pm 9.6\%$
		Y	5.11	67.37	17.55		150.0	
		Z	5.12	67.70	17.90		150.0	
10021- DAC	GSM-FDD (TDMA, GMSK)	X	50.38	109.96	29.91	9.39	50.0	$\pm 9.6\%$
		Y	44.87	108.65	29.87		50.0	
		Z	100.00	121.19	32.58		50.0	
10023- DAC	GPRS-FDD (TDMA, GMSK, TN 0)	X	38.97	105.78	28.82	9.57	50.0	$\pm 9.6\%$
		Y	34.67	104.32	28.72		50.0	
		Z	100.00	121.17	32.63		50.0	
10024- DAC	GPRS-FDD (TDMA, GMSK, TN 0-1)	X	100.00	117.95	30.08	6.56	60.0	$\pm 9.6\%$
		Y	100.00	118.51	30.45		60.0	
		Z	100.00	118.75	30.27		60.0	
10025- DAC	EDGE-FDD (TDMA, 8PSK, TN 0)	X	50.01	138.88	51.87	12.57	50.0	$\pm 9.6\%$
		Y	16.98	103.84	39.71		50.0	
		Z	38.73	132.84	50.41		50.0	
10026- DAC	EDGE-FDD (TDMA, 8PSK, TN 0-1)	X	35.46	119.89	41.37	9.56	60.0	$\pm 9.6\%$
		Y	22.06	106.97	37.01		60.0	
		Z	41.81	125.63	43.40		60.0	
10027- DAC	GPRS-FDD (TDMA, GMSK, TN 0-1-2)	X	100.00	117.25	28.87	4.80	80.0	$\pm 9.6\%$
		Y	100.00	117.48	29.06		80.0	
		Z	100.00	118.84	29.46		80.0	
10028- DAC	GPRS-FDD (TDMA, GMSK, TN 0-1-2-3)	X	100.00	117.96	28.39	3.55	100.0	$\pm 9.6\%$
		Y	100.00	117.75	28.37		100.0	
		Z	100.00	120.65	29.49		100.0	
10029- DAC	EDGE-FDD (TDMA, 8PSK, TN 0-1-2)	X	19.28	104.88	35.49	7.80	80.0	$\pm 9.6\%$
		Y	14.07	96.63	32.42		80.0	
		Z	20.06	107.12	36.54		80.0	
10030- CAA	IEEE 802.15.1 Bluetooth (GFSK, DH1)	X	100.00	116.63	28.91	5.30	70.0	$\pm 9.6\%$
		Y	100.00	116.93	29.14		70.0	
		Z	100.00	117.70	29.26		70.0	
10031- CAA	IEEE 802.15.1 Bluetooth (GFSK, DH3)	X	100.00	120.56	27.97	1.88	100.0	$\pm 9.6\%$
		Y	100.00	118.66	27.19		100.0	
		Z	100.00	126.63	30.49		100.0	

10032-CAA	IEEE 802.15.1 Bluetooth (GFSK, DH5)	X	100.00	128.07	29.96	1.17	100.0	± 9.6 %
		Y	100.00	123.28	28.00		100.0	
		Z	100.00	141.07	35.28		100.0	
10033-CAA	IEEE 802.15.1 Bluetooth (PI/4-DQPSK, DH1)	X	43.99	112.54	31.22	5.30	70.0	± 9.6 %
		Y	26.02	103.18	28.50		70.0	
		Z	100.00	126.99	34.88		70.0	
10034-CAA	IEEE 802.15.1 Bluetooth (PI/4-DQPSK, DH3)	X	22.91	104.90	27.62	1.88	100.0	± 9.6 %
		Y	12.27	94.53	24.31		100.0	
		Z	100.00	128.12	33.47		100.0	
10035-CAA	IEEE 802.15.1 Bluetooth (PI/4-DQPSK, DH5)	X	10.17	94.66	24.53	1.17	100.0	± 9.6 %
		Y	6.03	86.03	21.40		100.0	
		Z	100.00	129.58	33.57		100.0	
10036-CAA	IEEE 802.15.1 Bluetooth (8-DPSK, DH1)	X	64.69	119.13	32.96	5.30	70.0	± 9.6 %
		Y	34.68	108.08	29.93		70.0	
		Z	100.00	127.22	35.00		70.0	
10037-CAA	IEEE 802.15.1 Bluetooth (8-DPSK, DH3)	X	21.57	104.03	27.34	1.88	100.0	± 9.6 %
		Y	11.35	93.46	23.95		100.0	
		Z	100.00	128.11	33.43		100.0	
10038-CAA	IEEE 802.15.1 Bluetooth (8-DPSK, DH5)	X	10.97	96.14	25.08	1.17	100.0	± 9.6 %
		Y	6.35	87.07	21.84		100.0	
		Z	100.00	130.31	33.90		100.0	
10039-CAB	CDMA2000 (1xRTT, RC1)	X	3.20	80.44	19.80	0.00	150.0	± 9.6 %
		Y	2.29	75.23	17.35		150.0	
		Z	11.88	100.98	26.51		150.0	
10042-CAB	IS-54 / IS-136 FDD (TDMA/FDM, PI/4-DQPSK, Halfrate)	X	100.00	116.59	29.68	7.78	50.0	± 9.6 %
		Y	100.00	117.23	30.11		50.0	
		Z	100.00	116.98	29.67		50.0	
10044-CAA	IS-91/EIA/TIA-553 FDD (FDMA, FM)	X	0.03	131.84	12.80	0.00	150.0	± 9.6 %
		Y	0.00	109.47	3.03		150.0	
		Z	0.02	60.00	8.00		150.0	
10048-CAA	DECT (TDD, TDMA/FDM, GFSK, Full Slot, 24)	X	14.72	88.78	25.46	13.80	25.0	± 9.6 %
		Y	14.14	87.99	25.47		25.0	
		Z	23.63	97.71	28.12		25.0	
10049-CAA	DECT (TDD, TDMA/FDM, GFSK, Double Slot, 12)	X	19.10	93.91	25.74	10.79	40.0	± 9.6 %
		Y	18.21	93.30	25.83		40.0	
		Z	39.23	106.27	29.23		40.0	
10056-CAA	UMTS-TDD (TD-SCDMA, 1.28 Mcps)	X	18.24	94.41	26.86	9.03	50.0	± 9.6 %
		Y	15.68	91.39	25.87		50.0	
		Z	27.99	102.68	29.38		50.0	
10058-DAC	EDGE-FDD (TDMA, 8PSK, TN 0-1-2-3)	X	12.48	95.42	31.54	6.55	100.0	± 9.6 %
		Y	10.03	89.81	29.27		100.0	
		Z	12.45	96.50	32.24		100.0	
10059-CAB	IEEE 802.11b WiFi 2.4 GHz (DSSS, 2 Mbps)	X	1.58	69.48	18.48	0.61	110.0	± 9.6 %
		Y	1.51	68.18	17.54		110.0	
		Z	1.69	71.32	19.83		110.0	
10060-CAB	IEEE 802.11b WiFi 2.4 GHz (DSSS, 5.5 Mbps)	X	100.00	134.61	35.09	1.30	110.0	± 9.6 %
		Y	100.00	132.26	34.07		110.0	
		Z	100.00	139.79	37.36		110.0	

10061-CAB	IEEE 802.11b WiFi 2.4 GHz (DSSS, 11 Mbps)	X	48.51	124.63	35.13	2.04	110.0	± 9.6 %
		Y	17.31	105.89	29.95		110.0	
		Z	100.00	140.23	39.46		110.0	
10062-CAB	IEEE 802.11a/h WiFi 5 GHz (OFDM, 6 Mbps)	X	4.87	67.28	16.99	0.49	100.0	± 9.6 %
		Y	4.83	67.13	16.84		100.0	
		Z	4.87	67.54	17.23		100.0	
10063-CAB	IEEE 802.11a/h WiFi 5 GHz (OFDM, 9 Mbps)	X	4.91	67.44	17.13	0.72	100.0	± 9.6 %
		Y	4.87	67.29	16.98		100.0	
		Z	4.91	67.70	17.37		100.0	
10064-CAB	IEEE 802.11a/h WiFi 5 GHz (OFDM, 12 Mbps)	X	5.23	67.76	17.38	0.86	100.0	± 9.6 %
		Y	5.18	67.60	17.23		100.0	
		Z	5.22	67.98	17.60		100.0	
10065-CAB	IEEE 802.11a/h WiFi 5 GHz (OFDM, 18 Mbps)	X	5.13	67.79	17.56	1.21	100.0	± 9.6 %
		Y	5.09	67.64	17.41		100.0	
		Z	5.11	68.00	17.77		100.0	
10066-CAB	IEEE 802.11a/h WiFi 5 GHz (OFDM, 24 Mbps)	X	5.19	67.92	17.79	1.46	100.0	± 9.6 %
		Y	5.15	67.78	17.64		100.0	
		Z	5.16	68.12	18.00		100.0	
10067-CAB	IEEE 802.11a/h WiFi 5 GHz (OFDM, 36 Mbps)	X	5.50	68.09	18.25	2.04	100.0	± 9.6 %
		Y	5.47	67.97	18.11		100.0	
		Z	5.47	68.28	18.44		100.0	
10068-CAB	IEEE 802.11a/h WiFi 5 GHz (OFDM, 48 Mbps)	X	5.63	68.44	18.63	2.55	100.0	± 9.6 %
		Y	5.60	68.28	18.46		100.0	
		Z	5.59	68.55	18.78		100.0	
10069-CAB	IEEE 802.11a/h WiFi 5 GHz (OFDM, 54 Mbps)	X	5.71	68.40	18.83	2.67	100.0	± 9.6 %
		Y	5.68	68.26	18.65		100.0	
		Z	5.67	68.53	18.97		100.0	
10071-CAB	IEEE 802.11g WiFi 2.4 GHz (DSSS/OFDM, 9 Mbps)	X	5.28	67.72	18.08	1.99	100.0	± 9.6 %
		Y	5.25	67.61	17.94		100.0	
		Z	5.26	67.91	18.27		100.0	
10072-CAB	IEEE 802.11g WiFi 2.4 GHz (DSSS/OFDM, 12 Mbps)	X	5.34	68.30	18.42	2.30	100.0	± 9.6 %
		Y	5.31	68.17	18.27		100.0	
		Z	5.31	68.47	18.61		100.0	
10073-CAB	IEEE 802.11g WiFi 2.4 GHz (DSSS/OFDM, 18 Mbps)	X	5.47	68.66	18.85	2.83	100.0	± 9.6 %
		Y	5.45	68.53	18.69		100.0	
		Z	5.43	68.82	19.03		100.0	
10074-CAB	IEEE 802.11g WiFi 2.4 GHz (DSSS/OFDM, 24 Mbps)	X	5.50	68.72	19.10	3.30	100.0	± 9.6 %
		Y	5.49	68.61	18.95		100.0	
		Z	5.46	68.85	19.26		100.0	
10075-CAB	IEEE 802.11g WiFi 2.4 GHz (DSSS/OFDM, 36 Mbps)	X	5.65	69.22	19.62	3.82	90.0	± 9.6 %
		Y	5.63	69.06	19.43		90.0	
		Z	5.59	69.28	19.74		90.0	
10076-CAB	IEEE 802.11g WiFi 2.4 GHz (DSSS/OFDM, 48 Mbps)	X	5.66	69.02	19.75	4.15	90.0	± 9.6 %
		Y	5.65	68.89	19.57		90.0	
		Z	5.60	69.08	19.87		90.0	
10077-CAB	IEEE 802.11g WiFi 2.4 GHz (DSSS/OFDM, 54 Mbps)	X	5.69	69.11	19.86	4.30	90.0	± 9.6 %
		Y	5.70	68.99	19.68		90.0	
		Z	5.64	69.18	19.98		90.0	

10081-CAB	CDMA2000 (1xRTT, RC3)	X	1.38	73.33	16.77	0.00	150.0	± 9.6 %
		Y	0.99	68.32	14.00		150.0	
		Z	3.92	89.84	23.08		150.0	
10082-CAB	IS-54 / IS-136 FDD (TDMA/FDM, PI/4-DQPSK, Fullrate)	X	2.00	63.70	8.48	4.77	80.0	± 9.6 %
		Y	2.04	63.70	8.57		80.0	
		Z	1.92	63.74	8.38		80.0	
10090-DAC	GPRS-FDD (TDMA, GMSK, TN 0-4)	X	100.00	118.03	30.14	6.56	60.0	± 9.6 %
		Y	100.00	118.59	30.51		60.0	
		Z	100.00	118.82	30.33		60.0	
10097-CAB	UMTS-FDD (HSDPA)	X	2.03	69.76	17.11	0.00	150.0	± 9.6 %
		Y	1.91	68.55	16.27		150.0	
		Z	2.27	72.26	18.56		150.0	
10098-CAB	UMTS-FDD (HSUPA, Subtest 2)	X	2.00	69.79	17.12	0.00	150.0	± 9.6 %
		Y	1.87	68.53	16.25		150.0	
		Z	2.24	72.36	18.61		150.0	
10099-DAC	EDGE-FDD (TDMA, 8PSK, TN 0-4)	X	35.11	119.59	41.28	9.56	60.0	± 9.6 %
		Y	21.95	106.81	36.96		60.0	
		Z	41.44	125.35	43.31		60.0	
10100-CAD	LTE-FDD (SC-FDMA, 100% RB, 20 MHz, QPSK)	X	3.55	72.57	17.86	0.00	150.0	± 9.6 %
		Y	3.31	71.30	17.17		150.0	
		Z	3.84	74.35	18.92		150.0	
10101-CAD	LTE-FDD (SC-FDMA, 100% RB, 20 MHz, 16-QAM)	X	3.44	68.66	16.65	0.00	150.0	± 9.6 %
		Y	3.34	68.08	16.26		150.0	
		Z	3.52	69.37	17.19		150.0	
10102-CAD	LTE-FDD (SC-FDMA, 100% RB, 20 MHz, 64-QAM)	X	3.53	68.49	16.67	0.00	150.0	± 9.6 %
		Y	3.44	67.99	16.32		150.0	
		Z	3.60	69.15	17.19		150.0	
10103-CAD	LTE-TDD (SC-FDMA, 100% RB, 20 MHz, QPSK)	X	9.32	80.19	22.17	3.98	65.0	± 9.6 %
		Y	8.99	79.40	21.83		65.0	
		Z	9.79	81.73	22.96		65.0	
10104-CAD	LTE-TDD (SC-FDMA, 100% RB, 20 MHz, 16-QAM)	X	8.89	78.25	22.32	3.98	65.0	± 9.6 %
		Y	8.59	77.39	21.88		65.0	
		Z	8.97	78.98	22.77		65.0	
10105-CAD	LTE-TDD (SC-FDMA, 100% RB, 20 MHz, 64-QAM)	X	8.14	76.50	21.87	3.98	65.0	± 9.6 %
		Y	7.82	75.52	21.36		65.0	
		Z	8.44	77.76	22.56		65.0	
10108-CAE	LTE-FDD (SC-FDMA, 100% RB, 10 MHz, QPSK)	X	3.11	71.78	17.73	0.00	150.0	± 9.6 %
		Y	2.90	70.55	17.03		150.0	
		Z	3.35	73.62	18.84		150.0	
10109-CAE	LTE-FDD (SC-FDMA, 100% RB, 10 MHz, 16-QAM)	X	3.10	68.57	16.63	0.00	150.0	± 9.6 %
		Y	3.00	67.96	16.20		150.0	
		Z	3.19	69.45	17.27		150.0	
10110-CAE	LTE-FDD (SC-FDMA, 100% RB, 5 MHz, QPSK)	X	2.56	71.09	17.55	0.00	150.0	± 9.6 %
		Y	2.37	69.75	16.73		150.0	
		Z	2.80	73.24	18.82		150.0	
10111-CAE	LTE-FDD (SC-FDMA, 100% RB, 5 MHz, 16-QAM)	X	2.82	69.41	17.01	0.00	150.0	± 9.6 %
		Y	2.72	68.77	16.53		150.0	
		Z	2.98	70.89	17.92		150.0	

10112-CAE	LTE-FDD (SC-FDMA, 100% RB, 10 MHz, 64-QAM)	X	3.22	68.42	16.61	0.00	150.0	± 9.6 %
		Y	3.12	67.89	16.23		150.0	
		Z	3.29	69.25	17.21		150.0	
10113-CAE	LTE-FDD (SC-FDMA, 100% RB, 5 MHz, 64-QAM)	X	2.97	69.39	17.06	0.00	150.0	± 9.6 %
		Y	2.87	68.84	16.63		150.0	
		Z	3.11	70.79	17.91		150.0	
10114-CAB	IEEE 802.11n (HT Greenfield, 13.5 Mbps, BPSK)	X	5.25	67.62	16.75	0.00	150.0	± 9.6 %
		Y	5.21	67.48	16.62		150.0	
		Z	5.27	67.92	17.02		150.0	
10115-CAB	IEEE 802.11n (HT Greenfield, 81 Mbps, 16-QAM)	X	5.61	67.96	16.92	0.00	150.0	± 9.6 %
		Y	5.55	67.75	16.77		150.0	
		Z	5.60	68.12	17.12		150.0	
10116-CAB	IEEE 802.11n (HT Greenfield, 135 Mbps, 64-QAM)	X	5.37	67.91	16.82	0.00	150.0	± 9.6 %
		Y	5.33	67.75	16.68		150.0	
		Z	5.39	68.18	17.07		150.0	
10117-CAB	IEEE 802.11n (HT Mixed, 13.5 Mbps, BPSK)	X	5.24	67.59	16.75	0.00	150.0	± 9.6 %
		Y	5.18	67.39	16.59		150.0	
		Z	5.24	67.80	16.97		150.0	
10118-CAB	IEEE 802.11n (HT Mixed, 81 Mbps, 16-QAM)	X	5.70	68.16	17.04	0.00	150.0	± 9.6 %
		Y	5.65	68.00	16.90		150.0	
		Z	5.70	68.38	17.26		150.0	
10119-CAB	IEEE 802.11n (HT Mixed, 135 Mbps, 64-QAM)	X	5.35	67.85	16.80	0.00	150.0	± 9.6 %
		Y	5.30	67.68	16.66		150.0	
		Z	5.36	68.11	17.05		150.0	
10140-CAD	LTE-FDD (SC-FDMA, 100% RB, 15 MHz, 16-QAM)	X	3.57	68.50	16.59	0.00	150.0	± 9.6 %
		Y	3.48	67.99	16.24		150.0	
		Z	3.64	69.16	17.11		150.0	
10141-CAD	LTE-FDD (SC-FDMA, 100% RB, 15 MHz, 64-QAM)	X	3.69	68.49	16.70	0.00	150.0	± 9.6 %
		Y	3.60	68.05	16.39		150.0	
		Z	3.75	69.13	17.20		150.0	
10142-CAD	LTE-FDD (SC-FDMA, 100% RB, 3 MHz, QPSK)	X	2.37	71.41	17.48	0.00	150.0	± 9.6 %
		Y	2.16	69.87	16.52		150.0	
		Z	2.69	74.33	19.05		150.0	
10143-CAD	LTE-FDD (SC-FDMA, 100% RB, 3 MHz, 16-QAM)	X	2.75	70.51	17.02	0.00	150.0	± 9.6 %
		Y	2.61	69.67	16.39		150.0	
		Z	3.04	72.85	18.24		150.0	
10144-CAD	LTE-FDD (SC-FDMA, 100% RB, 3 MHz, 64-QAM)	X	2.53	68.33	15.53	0.00	150.0	± 9.6 %
		Y	2.38	67.41	14.82		150.0	
		Z	2.68	69.87	16.37		150.0	
10145-CAE	LTE-FDD (SC-FDMA, 100% RB, 1.4 MHz, QPSK)	X	1.72	69.83	14.97	0.00	150.0	± 9.6 %
		Y	1.42	67.06	13.18		150.0	
		Z	2.35	74.94	17.17		150.0	
10146-CAE	LTE-FDD (SC-FDMA, 100% RB, 1.4 MHz, 16-QAM)	X	6.48	82.85	19.80	0.00	150.0	± 9.6 %
		Y	4.60	77.64	17.45		150.0	
		Z	11.46	90.81	22.10		150.0	
10147-CAE	LTE-FDD (SC-FDMA, 100% RB, 1.4 MHz, 64-QAM)	X	11.52	91.11	22.66	0.00	150.0	± 9.6 %
		Y	8.23	85.64	20.41		150.0	
		Z	44.64	109.68	27.44		150.0	

10149-CAD	LTE-FDD (SC-FDMA, 50% RB, 20 MHz, 16-QAM)	X	3.11	68.62	16.67	0.00	150.0	± 9.6 %
		Y	3.01	68.02	16.24		150.0	
		Z	3.20	69.52	17.31		150.0	
10150-CAD	LTE-FDD (SC-FDMA, 50% RB, 20 MHz, 64-QAM)	X	3.22	68.47	16.65	0.00	150.0	± 9.6 %
		Y	3.13	67.94	16.27		150.0	
		Z	3.30	69.30	17.26		150.0	
10151-CAD	LTE-TDD (SC-FDMA, 50% RB, 20 MHz, QPSK)	X	10.10	82.94	23.33	3.98	65.0	± 9.6 %
		Y	9.61	81.89	22.87		65.0	
		Z	11.06	85.40	24.44		65.0	
10152-CAD	LTE-TDD (SC-FDMA, 50% RB, 20 MHz, 16-QAM)	X	8.61	78.74	22.29	3.98	65.0	± 9.6 %
		Y	8.25	77.70	21.74		65.0	
		Z	8.75	79.65	22.79		65.0	
10153-CAD	LTE-TDD (SC-FDMA, 50% RB, 20 MHz, 64-QAM)	X	8.97	79.41	22.89	3.98	65.0	± 9.6 %
		Y	8.65	78.52	22.42		65.0	
		Z	9.15	80.42	23.43		65.0	
10154-CAE	LTE-FDD (SC-FDMA, 50% RB, 10 MHz, QPSK)	X	2.62	71.53	17.81	0.00	150.0	± 9.6 %
		Y	2.43	70.20	17.01		150.0	
		Z	2.88	73.80	19.13		150.0	
10155-CAE	LTE-FDD (SC-FDMA, 50% RB, 10 MHz, 16-QAM)	X	2.82	69.42	17.03	0.00	150.0	± 9.6 %
		Y	2.72	68.78	16.55		150.0	
		Z	2.98	70.91	17.94		150.0	
10156-CAE	LTE-FDD (SC-FDMA, 50% RB, 5 MHz, QPSK)	X	2.27	72.03	17.59	0.00	150.0	± 9.6 %
		Y	2.03	70.19	16.46		150.0	
		Z	2.69	75.75	19.46		150.0	
10157-CAE	LTE-FDD (SC-FDMA, 50% RB, 5 MHz, 16-QAM)	X	2.42	69.36	15.84	0.00	150.0	± 9.6 %
		Y	2.24	68.18	14.98		150.0	
		Z	2.68	71.66	17.00		150.0	
10158-CAE	LTE-FDD (SC-FDMA, 50% RB, 10 MHz, 64-QAM)	X	2.97	69.44	17.10	0.00	150.0	± 9.6 %
		Y	2.87	68.90	16.67		150.0	
		Z	3.12	70.85	17.96		150.0	
10159-CAE	LTE-FDD (SC-FDMA, 50% RB, 5 MHz, 64-QAM)	X	2.53	69.76	16.09	0.00	150.0	± 9.6 %
		Y	2.35	68.64	15.26		150.0	
		Z	2.82	72.14	17.27		150.0	
10160-CAD	LTE-FDD (SC-FDMA, 50% RB, 15 MHz, QPSK)	X	3.03	70.37	17.34	0.00	150.0	± 9.6 %
		Y	2.89	69.52	16.79		150.0	
		Z	3.21	71.85	18.28		150.0	
10161-CAD	LTE-FDD (SC-FDMA, 50% RB, 15 MHz, 16-QAM)	X	3.12	68.40	16.61	0.00	150.0	± 9.6 %
		Y	3.02	67.87	16.21		150.0	
		Z	3.20	69.31	17.24		150.0	
10162-CAD	LTE-FDD (SC-FDMA, 50% RB, 15 MHz, 64-QAM)	X	3.22	68.45	16.67	0.00	150.0	± 9.6 %
		Y	3.13	67.97	16.30		150.0	
		Z	3.31	69.36	17.29		150.0	
10166-CAE	LTE-FDD (SC-FDMA, 50% RB, 1.4 MHz, QPSK)	X	4.12	72.10	20.82	3.01	150.0	± 9.6 %
		Y	4.00	71.56	20.43		150.0	
		Z	4.06	72.41	21.12		150.0	
10167-CAE	LTE-FDD (SC-FDMA, 50% RB, 1.4 MHz, 16-QAM)	X	5.55	76.59	21.87	3.01	150.0	± 9.6 %
		Y	5.29	75.66	21.32		150.0	
		Z	5.44	76.99	22.19		150.0	

10168-CAE	LTE-FDD (SC-FDMA, 50% RB, 1.4 MHz, 64-QAM)	X	6.16	78.89	23.12	3.01	150.0	± 9.6 %
		Y	5.95	78.24	22.73		150.0	
		Z	6.13	79.62	23.59		150.0	
10169-CAD	LTE-FDD (SC-FDMA, 1 RB, 20 MHz, QPSK)	X	3.77	73.91	21.75	3.01	150.0	± 9.6 %
		Y	3.57	72.54	20.95		150.0	
		Z	3.58	73.38	21.73		150.0	
10170-CAD	LTE-FDD (SC-FDMA, 1 RB, 20 MHz, 16-QAM)	X	6.47	84.03	25.38	3.01	150.0	± 9.6 %
		Y	5.79	81.57	24.28		150.0	
		Z	5.98	83.42	25.45		150.0	
10171-AAD	LTE-FDD (SC-FDMA, 1 RB, 20 MHz, 64-QAM)	X	5.04	78.45	22.28	3.01	150.0	± 9.6 %
		Y	4.51	76.03	21.10		150.0	
		Z	4.68	77.84	22.28		150.0	
10172-CAD	LTE-TDD (SC-FDMA, 1 RB, 20 MHz, QPSK)	X	100.00	137.35	41.72	6.02	65.0	± 9.6 %
		Y	67.19	128.64	39.39		65.0	
		Z	100.00	139.83	42.79		65.0	
10173-CAD	LTE-TDD (SC-FDMA, 1 RB, 20 MHz, 16-QAM)	X	100.00	129.26	37.48	6.02	65.0	± 9.6 %
		Y	100.00	129.10	37.42		65.0	
		Z	100.00	131.03	38.19		65.0	
10174-CAD	LTE-TDD (SC-FDMA, 1 RB, 20 MHz, 64-QAM)	X	100.00	127.24	36.41	6.02	65.0	± 9.6 %
		Y	65.07	119.30	34.36		65.0	
		Z	100.00	129.02	37.12		65.0	
10175-CAE	LTE-FDD (SC-FDMA, 1 RB, 10 MHz, QPSK)	X	3.72	73.54	21.49	3.01	150.0	± 9.6 %
		Y	3.52	72.16	20.68		150.0	
		Z	3.53	73.03	21.47		150.0	
10176-CAE	LTE-FDD (SC-FDMA, 1 RB, 10 MHz, 16-QAM)	X	6.48	84.06	25.39	3.01	150.0	± 9.6 %
		Y	5.80	81.60	24.30		150.0	
		Z	6.00	83.46	25.46		150.0	
10177-CAG	LTE-FDD (SC-FDMA, 1 RB, 5 MHz, QPSK)	X	3.76	73.72	21.59	3.01	150.0	± 9.6 %
		Y	3.55	72.35	20.78		150.0	
		Z	3.56	73.20	21.57		150.0	
10178-CAE	LTE-FDD (SC-FDMA, 1 RB, 5 MHz, 16-QAM)	X	6.37	83.70	25.23	3.01	150.0	± 9.6 %
		Y	5.71	81.26	24.14		150.0	
		Z	5.90	83.12	25.31		150.0	
10179-CAE	LTE-FDD (SC-FDMA, 1 RB, 10 MHz, 64-QAM)	X	5.71	81.14	23.70	3.01	150.0	± 9.6 %
		Y	5.10	78.67	22.56		150.0	
		Z	5.31	80.60	23.77		150.0	
10180-CAE	LTE-FDD (SC-FDMA, 1 RB, 5 MHz, 64-QAM)	X	5.02	78.34	22.21	3.01	150.0	± 9.6 %
		Y	4.49	75.93	21.04		150.0	
		Z	4.66	77.74	22.22		150.0	
10181-CAD	LTE-FDD (SC-FDMA, 1 RB, 15 MHz, QPSK)	X	3.75	73.70	21.58	3.01	150.0	± 9.6 %
		Y	3.54	72.33	20.77		150.0	
		Z	3.56	73.19	21.56		150.0	
10182-CAD	LTE-FDD (SC-FDMA, 1 RB, 15 MHz, 16-QAM)	X	6.36	83.67	25.22	3.01	150.0	± 9.6 %
		Y	5.70	81.23	24.13		150.0	
		Z	5.89	83.09	25.29		150.0	
10183-AAC	LTE-FDD (SC-FDMA, 1 RB, 15 MHz, 64-QAM)	X	5.01	78.31	22.20	3.01	150.0	± 9.6 %
		Y	4.48	75.90	21.03		150.0	
		Z	4.65	77.70	22.20		150.0	

10184-CAD	LTE-FDD (SC-FDMA, 1 RB, 3 MHz, QPSK)	X	3.76	73.75	21.60	3.01	150.0	± 9.6 %
		Y	3.56	72.37	20.80		150.0	
		Z	3.57	73.23	21.58		150.0	
10185-CAD	LTE-FDD (SC-FDMA, 1 RB, 3 MHz, 16-QAM)	X	6.40	83.76	25.26	3.01	150.0	± 9.6 %
		Y	5.73	81.32	24.17		150.0	
		Z	5.93	83.18	25.34		150.0	
10186-AAD	LTE-FDD (SC-FDMA, 1 RB, 3 MHz, 64-QAM)	X	5.04	78.40	22.24	3.01	150.0	± 9.6 %
		Y	4.51	75.98	21.07		150.0	
		Z	4.68	77.80	22.25		150.0	
10187-CAE	LTE-FDD (SC-FDMA, 1 RB, 1.4 MHz, QPSK)	X	3.77	73.80	21.66	3.01	150.0	± 9.6 %
		Y	3.57	72.43	20.86		150.0	
		Z	3.58	73.29	21.64		150.0	
10188-CAE	LTE-FDD (SC-FDMA, 1 RB, 1.4 MHz, 16-QAM)	X	6.68	84.71	25.71	3.01	150.0	± 9.6 %
		Y	5.99	82.25	24.62		150.0	
		Z	6.18	84.12	25.79		150.0	
10189-AAE	LTE-FDD (SC-FDMA, 1 RB, 1.4 MHz, 64-QAM)	X	5.19	79.00	22.56	3.01	150.0	± 9.6 %
		Y	4.64	76.56	21.39		150.0	
		Z	4.82	78.39	22.57		150.0	
10193-CAB	IEEE 802.11n (HT Greenfield, 6.5 Mbps, BPSK)	X	4.65	67.05	16.52	0.00	150.0	± 9.6 %
		Y	4.60	66.87	16.34		150.0	
		Z	4.66	67.35	16.78		150.0	
10194-CAB	IEEE 802.11n (HT Greenfield, 39 Mbps, 16-QAM)	X	4.85	67.41	16.64	0.00	150.0	± 9.6 %
		Y	4.78	67.21	16.46		150.0	
		Z	4.85	67.69	16.90		150.0	
10195-CAB	IEEE 802.11n (HT Greenfield, 65 Mbps, 64-QAM)	X	4.89	67.42	16.65	0.00	150.0	± 9.6 %
		Y	4.83	67.23	16.48		150.0	
		Z	4.89	67.71	16.91		150.0	
10196-CAB	IEEE 802.11n (HT Mixed, 6.5 Mbps, BPSK)	X	4.67	67.14	16.55	0.00	150.0	± 9.6 %
		Y	4.61	66.95	16.37		150.0	
		Z	4.67	67.44	16.81		150.0	
10197-CAB	IEEE 802.11n (HT Mixed, 39 Mbps, 16-QAM)	X	4.86	67.43	16.65	0.00	150.0	± 9.6 %
		Y	4.80	67.23	16.48		150.0	
		Z	4.86	67.72	16.91		150.0	
10198-CAB	IEEE 802.11n (HT Mixed, 65 Mbps, 64-QAM)	X	4.89	67.44	16.66	0.00	150.0	± 9.6 %
		Y	4.83	67.25	16.49		150.0	
		Z	4.89	67.74	16.92		150.0	
10219-CAB	IEEE 802.11n (HT Mixed, 7.2 Mbps, BPSK)	X	4.62	67.16	16.52	0.00	150.0	± 9.6 %
		Y	4.56	66.97	16.33		150.0	
		Z	4.63	67.47	16.78		150.0	
10220-CAB	IEEE 802.11n (HT Mixed, 43.3 Mbps, 16-QAM)	X	4.86	67.41	16.64	0.00	150.0	± 9.6 %
		Y	4.80	67.21	16.47		150.0	
		Z	4.86	67.69	16.90		150.0	
10221-CAB	IEEE 802.11n (HT Mixed, 72.2 Mbps, 64-QAM)	X	4.90	67.37	16.64	0.00	150.0	± 9.6 %
		Y	4.84	67.18	16.48		150.0	
		Z	4.90	67.65	16.90		150.0	
10222-CAB	IEEE 802.11n (HT Mixed, 15 Mbps, BPSK)	X	5.22	67.61	16.75	0.00	150.0	± 9.6 %
		Y	5.16	67.40	16.59		150.0	
		Z	5.22	67.81	16.97		150.0	

10223-CAB	IEEE 802.11n (HT Mixed, 90 Mbps, 16-QAM)	X	5.55	67.86	16.90	0.00	150.0	± 9.6 %
		Y	5.48	67.61	16.72		150.0	
		Z	5.53	67.99	17.08		150.0	
10224-CAB	IEEE 802.11n (HT Mixed, 150 Mbps, 64-QAM)	X	5.26	67.70	16.72	0.00	150.0	± 9.6 %
		Y	5.21	67.50	16.56		150.0	
		Z	5.27	67.93	16.96		150.0	
10225-CAB	UMTS-FDD (HSPA+)	X	2.95	66.92	16.04	0.00	150.0	± 9.6 %
		Y	2.88	66.53	15.67		150.0	
		Z	3.00	67.65	16.54		150.0	
10226-CAA	LTE-TDD (SC-FDMA, 1 RB, 1.4 MHz, 16-QAM)	X	100.00	129.45	37.61	6.02	65.0	± 9.6 %
		Y	100.00	129.29	37.54		65.0	
		Z	100.00	131.22	38.32		65.0	
10227-CAA	LTE-TDD (SC-FDMA, 1 RB, 1.4 MHz, 64-QAM)	X	100.00	127.42	36.54	6.02	65.0	± 9.6 %
		Y	76.12	122.32	35.23		65.0	
		Z	100.00	128.99	37.15		65.0	
10228-CAA	LTE-TDD (SC-FDMA, 1 RB, 1.4 MHz, QPSK)	X	100.00	137.91	41.98	6.02	65.0	± 9.6 %
		Y	72.71	130.80	40.06		65.0	
		Z	100.00	139.98	42.85		65.0	
10229-CAB	LTE-TDD (SC-FDMA, 1 RB, 3 MHz, 16-QAM)	X	100.00	129.25	37.49	6.02	65.0	± 9.6 %
		Y	100.00	129.09	37.42		65.0	
		Z	100.00	131.01	38.20		65.0	
10230-CAB	LTE-TDD (SC-FDMA, 1 RB, 3 MHz, 64-QAM)	X	100.00	127.28	36.44	6.02	65.0	± 9.6 %
		Y	69.40	120.51	34.70		65.0	
		Z	100.00	128.86	37.05		65.0	
10231-CAB	LTE-TDD (SC-FDMA, 1 RB, 3 MHz, QPSK)	X	100.00	137.77	41.88	6.02	65.0	± 9.6 %
		Y	66.12	128.70	39.45		65.0	
		Z	100.00	139.84	42.75		65.0	
10232-CAD	LTE-TDD (SC-FDMA, 1 RB, 5 MHz, 16-QAM)	X	100.00	129.26	37.49	6.02	65.0	± 9.6 %
		Y	100.00	129.10	37.42		65.0	
		Z	100.00	131.02	38.20		65.0	
10233-CAD	LTE-TDD (SC-FDMA, 1 RB, 5 MHz, 64-QAM)	X	100.00	127.29	36.44	6.02	65.0	± 9.6 %
		Y	69.52	120.56	34.71		65.0	
		Z	100.00	128.87	37.06		65.0	
10234-CAD	LTE-TDD (SC-FDMA, 1 RB, 5 MHz, QPSK)	X	100.00	137.49	41.71	6.02	65.0	± 9.6 %
		Y	60.36	126.57	38.80		65.0	
		Z	100.00	139.54	42.57		65.0	
10235-CAD	LTE-TDD (SC-FDMA, 1 RB, 10 MHz, 16-QAM)	X	100.00	129.28	37.49	6.02	65.0	± 9.6 %
		Y	100.00	129.12	37.43		65.0	
		Z	100.00	131.04	38.21		65.0	
10236-CAD	LTE-TDD (SC-FDMA, 1 RB, 10 MHz, 64-QAM)	X	100.00	127.25	36.42	6.02	65.0	± 9.6 %
		Y	70.59	120.79	34.76		65.0	
		Z	100.00	128.82	37.04		65.0	
10237-CAD	LTE-TDD (SC-FDMA, 1 RB, 10 MHz, QPSK)	X	100.00	137.79	41.88	6.02	65.0	± 9.6 %
		Y	67.33	129.09	39.56		65.0	
		Z	100.00	139.86	42.76		65.0	
10238-CAD	LTE-TDD (SC-FDMA, 1 RB, 15 MHz, 16-QAM)	X	100.00	129.27	37.49	6.02	65.0	± 9.6 %
		Y	100.00	129.11	37.42		65.0	
		Z	100.00	131.04	38.20		65.0	

10239-CAD	LTE-TDD (SC-FDMA, 1 RB, 15 MHz, 64-QAM)	X	100.00	127.31	36.45	6.02	65.0	± 9.6 %
		Y	69.64	120.60	34.72		65.0	
		Z	100.00	128.89	37.07		65.0	
10240-CAD	LTE-TDD (SC-FDMA, 1 RB, 15 MHz, QPSK)	X	100.00	137.80	41.89	6.02	65.0	± 9.6 %
		Y	67.01	129.01	39.53		65.0	
		Z	100.00	139.88	42.76		65.0	
10241-CAA	LTE-TDD (SC-FDMA, 50% RB, 1.4 MHz, 16-QAM)	X	14.83	92.29	30.01	6.98	65.0	± 9.6 %
		Y	13.65	90.03	28.96		65.0	
		Z	14.80	93.09	30.38		65.0	
10242-CAA	LTE-TDD (SC-FDMA, 50% RB, 1.4 MHz, 64-QAM)	X	14.59	91.90	29.80	6.98	65.0	± 9.6 %
		Y	13.15	89.18	28.56		65.0	
		Z	13.21	90.49	29.34		65.0	
10243-CAA	LTE-TDD (SC-FDMA, 50% RB, 1.4 MHz, QPSK)	X	11.35	88.48	29.59	6.98	65.0	± 9.6 %
		Y	10.30	85.71	28.22		65.0	
		Z	10.07	86.37	28.82		65.0	
10244-CAB	LTE-TDD (SC-FDMA, 50% RB, 3 MHz, 16-QAM)	X	11.72	84.97	22.91	3.98	65.0	± 9.6 %
		Y	10.99	83.58	22.20		65.0	
		Z	12.79	86.87	23.44		65.0	
10245-CAB	LTE-TDD (SC-FDMA, 50% RB, 3 MHz, 64-QAM)	X	11.34	84.17	22.57	3.98	65.0	± 9.6 %
		Y	10.64	82.78	21.85		65.0	
		Z	12.16	85.75	22.99		65.0	
10246-CAB	LTE-TDD (SC-FDMA, 50% RB, 3 MHz, QPSK)	X	11.48	87.15	23.44	3.98	65.0	± 9.6 %
		Y	10.09	84.69	22.39		65.0	
		Z	14.93	92.12	25.09		65.0	
10247-CAD	LTE-TDD (SC-FDMA, 50% RB, 5 MHz, 16-QAM)	X	8.24	79.59	21.31	3.98	65.0	± 9.6 %
		Y	7.80	78.37	20.63		65.0	
		Z	8.75	81.21	21.92		65.0	
10248-CAD	LTE-TDD (SC-FDMA, 50% RB, 5 MHz, 64-QAM)	X	8.17	78.99	21.06	3.98	65.0	± 9.6 %
		Y	7.71	77.75	20.37		65.0	
		Z	8.53	80.31	21.56		65.0	
10249-CAD	LTE-TDD (SC-FDMA, 50% RB, 5 MHz, QPSK)	X	12.80	89.43	24.93	3.98	65.0	± 9.6 %
		Y	11.40	87.14	23.99		65.0	
		Z	16.84	94.99	26.84		65.0	
10250-CAD	LTE-TDD (SC-FDMA, 50% RB, 10 MHz, 16-QAM)	X	9.14	81.59	23.40	3.98	65.0	± 9.6 %
		Y	8.74	80.52	22.85		65.0	
		Z	9.63	83.27	24.17		65.0	
10251-CAD	LTE-TDD (SC-FDMA, 50% RB, 10 MHz, 64-QAM)	X	8.56	79.26	22.22	3.98	65.0	± 9.6 %
		Y	8.18	78.19	21.64		65.0	
		Z	8.81	80.43	22.77		65.0	
10252-CAD	LTE-TDD (SC-FDMA, 50% RB, 10 MHz, QPSK)	X	11.72	87.47	24.98	3.98	65.0	± 9.6 %
		Y	10.81	85.79	24.29		65.0	
		Z	13.94	91.53	26.58		65.0	
10253-CAD	LTE-TDD (SC-FDMA, 50% RB, 15 MHz, 16-QAM)	X	8.35	78.06	22.04	3.98	65.0	± 9.6 %
		Y	8.03	77.10	21.51		65.0	
		Z	8.47	78.91	22.50		65.0	
10254-CAD	LTE-TDD (SC-FDMA, 50% RB, 15 MHz, 64-QAM)	X	8.72	78.75	22.61	3.98	65.0	± 9.6 %
		Y	8.43	77.90	22.13		65.0	
		Z	8.87	79.69	23.10		65.0	

10255-CAD	LTE-TDD (SC-FDMA, 50% RB, 15 MHz, QPSK)	X	9.73	82.56	23.43	3.98	65.0	± 9.6 %
		Y	9.26	81.48	22.94		65.0	
		Z	10.55	84.84	24.47		65.0	
10256-CAA	LTE-TDD (SC-FDMA, 100% RB, 1.4 MHz, 16-QAM)	X	10.24	82.17	21.04	3.98	65.0	± 9.6 %
		Y	9.40	80.46	20.17		65.0	
		Z	10.73	83.20	21.19		65.0	
10257-CAA	LTE-TDD (SC-FDMA, 100% RB, 1.4 MHz, 64-QAM)	X	9.75	81.02	20.53	3.98	65.0	± 9.6 %
		Y	8.95	79.33	19.65		65.0	
		Z	9.97	81.66	20.53		65.0	
10258-CAA	LTE-TDD (SC-FDMA, 100% RB, 1.4 MHz, QPSK)	X	9.29	83.12	21.37	3.98	65.0	± 9.6 %
		Y	8.11	80.61	20.22		65.0	
		Z	11.03	86.29	22.38		65.0	
10259-CAB	LTE-TDD (SC-FDMA, 100% RB, 3 MHz, 16-QAM)	X	8.60	80.29	22.04	3.98	65.0	± 9.6 %
		Y	8.17	79.14	21.42		65.0	
		Z	9.10	81.94	22.71		65.0	
10260-CAB	LTE-TDD (SC-FDMA, 100% RB, 3 MHz, 64-QAM)	X	8.56	79.91	21.91	3.98	65.0	± 9.6 %
		Y	8.14	78.78	21.29		65.0	
		Z	8.98	81.38	22.51		65.0	
10261-CAB	LTE-TDD (SC-FDMA, 100% RB, 3 MHz, QPSK)	X	11.70	87.77	24.70	3.98	65.0	± 9.6 %
		Y	10.60	85.76	23.85		65.0	
		Z	14.35	92.23	26.34		65.0	
10262-CAD	LTE-TDD (SC-FDMA, 100% RB, 5 MHz, 16-QAM)	X	9.13	81.55	23.37	3.98	65.0	± 9.6 %
		Y	8.73	80.47	22.82		65.0	
		Z	9.62	83.22	24.13		65.0	
10263-CAD	LTE-TDD (SC-FDMA, 100% RB, 5 MHz, 64-QAM)	X	8.55	79.25	22.22	3.98	65.0	± 9.6 %
		Y	8.17	78.17	21.63		65.0	
		Z	8.80	80.41	22.76		65.0	
10264-CAD	LTE-TDD (SC-FDMA, 100% RB, 5 MHz, QPSK)	X	11.63	87.30	24.91	3.98	65.0	± 9.6 %
		Y	10.72	85.62	24.21		65.0	
		Z	13.79	91.31	26.48		65.0	
10265-CAD	LTE-TDD (SC-FDMA, 100% RB, 10 MHz, 16-QAM)	X	8.61	78.74	22.29	3.98	65.0	± 9.6 %
		Y	8.25	77.71	21.75		65.0	
		Z	8.75	79.65	22.79		65.0	
10266-CAD	LTE-TDD (SC-FDMA, 100% RB, 10 MHz, 64-QAM)	X	8.96	79.40	22.89	3.98	65.0	± 9.6 %
		Y	8.65	78.51	22.41		65.0	
		Z	9.14	80.41	23.42		65.0	
10267-CAD	LTE-TDD (SC-FDMA, 100% RB, 10 MHz, QPSK)	X	10.08	82.90	23.31	3.98	65.0	± 9.6 %
		Y	9.59	81.85	22.86		65.0	
		Z	11.04	85.35	24.42		65.0	
10268-CAD	LTE-TDD (SC-FDMA, 100% RB, 15 MHz, 16-QAM)	X	8.92	77.83	22.28	3.98	65.0	± 9.6 %
		Y	8.66	77.07	21.87		65.0	
		Z	8.98	78.50	22.70		65.0	
10269-CAD	LTE-TDD (SC-FDMA, 100% RB, 15 MHz, 64-QAM)	X	8.81	77.35	22.16	3.98	65.0	± 9.6 %
		Y	8.58	76.63	21.76		65.0	
		Z	8.85	77.96	22.54		65.0	
10270-CAD	LTE-TDD (SC-FDMA, 100% RB, 15 MHz, QPSK)	X	9.12	79.35	22.10	3.98	65.0	± 9.6 %
		Y	8.86	78.67	21.79		65.0	
		Z	9.49	80.74	22.83		65.0	

10274-CAB	UMTS-FDD (HSUPA, Subtest 5, 3GPP Rel8.10)	X	2.72	67.41	16.03	0.00	150.0	± 9.6 %
		Y	2.65	66.91	15.59		150.0	
		Z	2.82	68.44	16.69		150.0	
10275-CAB	UMTS-FDD (HSUPA, Subtest 5, 3GPP Rel8.4)	X	1.92	71.20	17.51	0.00	150.0	± 9.6 %
		Y	1.73	69.25	16.33		150.0	
		Z	2.25	74.57	19.38		150.0	
10277-CAA	PHS (QPSK)	X	5.16	68.88	13.28	9.03	50.0	± 9.6 %
		Y	5.22	68.83	13.33		50.0	
		Z	4.81	68.30	12.68		50.0	
10278-CAA	PHS (QPSK, BW 884MHz, Rolloff 0.5)	X	9.78	81.37	21.03	9.03	50.0	± 9.6 %
		Y	8.99	79.58	20.31		50.0	
		Z	10.31	82.57	21.25		50.0	
10279-CAA	PHS (QPSK, BW 884MHz, Rolloff 0.38)	X	9.97	81.61	21.15	9.03	50.0	± 9.6 %
		Y	9.14	79.76	20.40		50.0	
		Z	10.50	82.78	21.35		50.0	
10290-AAB	CDMA2000, RC1, SO55, Full Rate	X	2.29	75.33	17.56	0.00	150.0	± 9.6 %
		Y	1.73	71.15	15.36		150.0	
		Z	4.93	87.41	22.07		150.0	
10291-AAB	CDMA2000, RC3, SO55, Full Rate	X	1.32	72.83	16.54	0.00	150.0	± 9.6 %
		Y	0.96	68.00	13.83		150.0	
		Z	3.56	88.42	22.61		150.0	
10292-AAB	CDMA2000, RC3, SO32, Full Rate	X	2.47	83.29	21.06	0.00	150.0	± 9.6 %
		Y	1.41	74.36	17.07		150.0	
		Z	100.00	141.64	36.82		150.0	
10293-AAB	CDMA2000, RC3, SO3, Full Rate	X	5.82	97.10	26.09	0.00	150.0	± 9.6 %
		Y	2.66	83.93	21.20		150.0	
		Z	100.00	145.56	38.71		150.0	
10295-AAB	CDMA2000, RC1, SO3, 1/8th Rate 25 fr.	X	12.82	88.35	25.85	9.03	50.0	± 9.6 %
		Y	12.13	86.63	25.04		50.0	
		Z	15.26	92.16	27.09		50.0	
10297-AAC	LTE-FDD (SC-FDMA, 50% RB, 20 MHz, QPSK)	X	3.12	71.89	17.79	0.00	150.0	± 9.6 %
		Y	2.92	70.65	17.10		150.0	
		Z	3.37	73.74	18.92		150.0	
10298-AAC	LTE-FDD (SC-FDMA, 50% RB, 3 MHz, QPSK)	X	2.07	71.88	16.72	0.00	150.0	± 9.6 %
		Y	1.77	69.44	15.22		150.0	
		Z	2.75	77.05	19.04		150.0	
10299-AAC	LTE-FDD (SC-FDMA, 50% RB, 3 MHz, 16-QAM)	X	6.37	82.96	20.78	0.00	150.0	± 9.6 %
		Y	5.31	79.88	19.28		150.0	
		Z	9.58	89.56	22.90		150.0	
10300-AAC	LTE-FDD (SC-FDMA, 50% RB, 3 MHz, 64-QAM)	X	3.53	73.03	16.17	0.00	150.0	± 9.6 %
		Y	2.95	70.35	14.64		150.0	
		Z	3.75	74.39	16.60		150.0	
10301-AAA	IEEE 802.16e WiMAX (29:18, 5ms, 10MHz, QPSK, PUSC)	X	5.90	69.43	19.63	4.17	80.0	± 9.6 %
		Y	5.76	68.84	19.14		80.0	
		Z	5.67	68.79	19.29		80.0	
10302-AAA	IEEE 802.16e WiMAX (29:18, 5ms, 10MHz, QPSK, PUSC, 3 CTRL symbols)	X	6.30	69.74	20.23	4.96	80.0	± 9.6 %
		Y	6.16	69.02	19.64		80.0	
		Z	6.18	69.57	20.16		80.0	

10303-AAA	IEEE 802.16e WiMAX (31:15, 5ms, 10MHz, 64QAM, PUSC)	X	6.16	69.89	20.33	4.96	80.0	± 9.6 %
		Y	6.00	69.08	19.68		80.0	
		Z	6.01	69.63	20.21		80.0	
10304-AAA	IEEE 802.16e WiMAX (29:18, 5ms, 10MHz, 64QAM, PUSC)	X	5.77	69.00	19.40	4.17	80.0	± 9.6 %
		Y	5.64	68.36	18.86		80.0	
		Z	5.67	68.94	19.39		80.0	
10305-AAA	IEEE 802.16e WiMAX (31:15, 10ms, 10MHz, 64QAM, PUSC, 15 symbols)	X	7.84	78.69	24.87	6.02	50.0	± 9.6 %
		Y	9.09	82.67	26.46		50.0	
		Z	8.68	82.73	26.94		50.0	
10306-AAA	IEEE 802.16e WiMAX (29:18, 10ms, 10MHz, 64QAM, PUSC, 18 symbols)	X	6.75	73.54	22.80	6.02	50.0	± 9.6 %
		Y	6.44	71.98	21.66		50.0	
		Z	6.43	72.74	22.36		50.0	
10307-AAA	IEEE 802.16e WiMAX (29:18, 10ms, 10MHz, QPSK, PUSC, 18 symbols)	X	6.91	74.50	23.06	6.02	50.0	± 9.6 %
		Y	6.52	72.66	21.80		50.0	
		Z	6.54	73.53	22.56		50.0	
10308-AAA	IEEE 802.16e WiMAX (29:18, 10ms, 10MHz, 16QAM, PUSC)	X	7.02	75.11	23.35	6.02	50.0	± 9.6 %
		Y	7.48	77.22	24.27		50.0	
		Z	6.63	74.11	22.85		50.0	
10309-AAA	IEEE 802.16e WiMAX (29:18, 10ms, 10MHz, 16QAM, AMC 2x3, 18 symbols)	X	6.90	73.98	23.04	6.02	50.0	± 9.6 %
		Y	6.54	72.31	21.85		50.0	
		Z	6.56	73.12	22.58		50.0	
10310-AAA	IEEE 802.16e WiMAX (29:18, 10ms, 10MHz, QPSK, AMC 2x3, 18 symbols)	X	6.79	73.89	22.87	6.02	50.0	± 9.6 %
		Y	6.45	72.23	21.69		50.0	
		Z	6.46	73.04	22.42		50.0	
10311-AAC	LTE-FDD (SC-FDMA, 100% RB, 15 MHz, QPSK)	X	3.49	70.94	17.30	0.00	150.0	± 9.6 %
		Y	3.28	69.84	16.68		150.0	
		Z	3.74	72.56	18.28		150.0	
10313-AAA	iDEN 1:3	X	9.34	82.16	20.02	6.99	70.0	± 9.6 %
		Y	8.31	80.30	19.40		70.0	
		Z	13.26	87.99	22.08		70.0	
10314-AAA	iDEN 1:6	X	13.74	91.13	25.52	10.00	30.0	± 9.6 %
		Y	11.69	88.12	24.57		30.0	
		Z	24.94	102.20	29.03		30.0	
10315-AAB	IEEE 802.11b WiFi 2.4 GHz (DSSS, 1 Mbps, 96pc duty cycle)	X	1.21	66.13	16.89	0.17	150.0	± 9.6 %
		Y	1.17	65.22	16.09		150.0	
		Z	1.28	67.59	18.12		150.0	
10316-AAB	IEEE 802.11g WiFi 2.4 GHz (ERP-OFDM, 6 Mbps, 96pc duty cycle)	X	4.76	67.25	16.74	0.17	150.0	± 9.6 %
		Y	4.71	67.07	16.57		150.0	
		Z	4.76	67.53	16.99		150.0	
10317-AAB	IEEE 802.11a WiFi 5 GHz (OFDM, 6 Mbps, 96pc duty cycle)	X	4.76	67.25	16.74	0.17	150.0	± 9.6 %
		Y	4.71	67.07	16.57		150.0	
		Z	4.76	67.53	16.99		150.0	
10400-AAC	IEEE 802.11ac WiFi (20MHz, 64-QAM, 99pc duty cycle)	X	4.86	67.51	16.66	0.00	150.0	± 9.6 %
		Y	4.79	67.29	16.47		150.0	
		Z	4.86	67.79	16.92		150.0	
10401-AAC	IEEE 802.11ac WiFi (40MHz, 64-QAM, 99pc duty cycle)	X	5.52	67.61	16.76	0.00	150.0	± 9.6 %
		Y	5.48	67.49	16.64		150.0	
		Z	5.54	67.90	17.02		150.0	

10402-AAC	IEEE 802.11ac WiFi (80MHz, 64-QAM, 99pc duty cycle)	X	5.80	68.01	16.79	0.00	150.0	± 9.6 %
		Y	5.74	67.81	16.64		150.0	
		Z	5.79	68.17	16.98		150.0	
10403-AAB	CDMA2000 (1xEV-DO, Rev. 0)	X	2.29	75.33	17.56	0.00	115.0	± 9.6 %
		Y	1.73	71.15	15.36		115.0	
		Z	4.93	87.41	22.07		115.0	
10404-AAB	CDMA2000 (1xEV-DO, Rev. A)	X	2.29	75.33	17.56	0.00	115.0	± 9.6 %
		Y	1.73	71.15	15.36		115.0	
		Z	4.93	87.41	22.07		115.0	
10406-AAB	CDMA2000, RC3, SO32, SCH0, Full Rate	X	100.00	126.38	32.92	0.00	100.0	± 9.6 %
		Y	100.00	125.07	32.28		100.0	
		Z	100.00	128.97	33.98		100.0	
10410-AAC	LTE-TDD (SC-FDMA, 1 RB, 10 MHz, QPSK, UL Subframe=2,3,4,7,8,9)	X	100.00	123.65	32.14	3.23	80.0	± 9.6 %
		Y	100.00	123.24	31.93		80.0	
		Z	100.00	126.05	33.09		80.0	
10415-AAA	IEEE 802.11b WiFi 2.4 GHz (DSSS, 1 Mbps, 99pc duty cycle)	X	1.05	64.38	15.91	0.00	150.0	± 9.6 %
		Y	1.02	63.59	15.15		150.0	
		Z	1.10	65.66	17.08		150.0	
10416-AAA	IEEE 802.11g WiFi 2.4 GHz (ERP-OFDM, 6 Mbps, 99pc duty cycle)	X	4.66	67.10	16.58	0.00	150.0	± 9.6 %
		Y	4.61	66.91	16.40		150.0	
		Z	4.67	67.40	16.84		150.0	
10417-AAA	IEEE 802.11a/h WiFi 5 GHz (OFDM, 6 Mbps, 99pc duty cycle)	X	4.66	67.10	16.58	0.00	150.0	± 9.6 %
		Y	4.61	66.91	16.40		150.0	
		Z	4.67	67.40	16.84		150.0	
10418-AAA	IEEE 802.11g WiFi 2.4 GHz (DSSS-OFDM, 6 Mbps, 99pc duty cycle, Long preamble)	X	4.65	67.25	16.59	0.00	150.0	± 9.6 %
		Y	4.59	67.07	16.42		150.0	
		Z	4.66	67.58	16.87		150.0	
10419-AAA	IEEE 802.11g WiFi 2.4 GHz (DSSS-OFDM, 6 Mbps, 99pc duty cycle, Short preamble)	X	4.67	67.20	16.59	0.00	150.0	± 9.6 %
		Y	4.62	67.02	16.42		150.0	
		Z	4.68	67.52	16.87		150.0	
10422-AAA	IEEE 802.11n (HT Greenfield, 7.2 Mbps, BPSK)	X	4.79	67.20	16.60	0.00	150.0	± 9.6 %
		Y	4.74	67.02	16.44		150.0	
		Z	4.80	67.49	16.86		150.0	
10423-AAA	IEEE 802.11n (HT Greenfield, 43.3 Mbps, 16-QAM)	X	4.98	67.56	16.73	0.00	150.0	± 9.6 %
		Y	4.92	67.36	16.56		150.0	
		Z	4.98	67.84	16.99		150.0	
10424-AAA	IEEE 802.11n (HT Greenfield, 72.2 Mbps, 64-QAM)	X	4.90	67.51	16.70	0.00	150.0	± 9.6 %
		Y	4.83	67.31	16.53		150.0	
		Z	4.90	67.80	16.97		150.0	
10425-AAA	IEEE 802.11n (HT Greenfield, 15 Mbps, BPSK)	X	5.49	67.84	16.87	0.00	150.0	± 9.6 %
		Y	5.45	67.70	16.74		150.0	
		Z	5.51	68.10	17.11		150.0	
10426-AAA	IEEE 802.11n (HT Greenfield, 90 Mbps, 16-QAM)	X	5.50	67.86	16.87	0.00	150.0	± 9.6 %
		Y	5.46	67.71	16.74		150.0	
		Z	5.51	68.12	17.11		150.0	

10427-AAA	IEEE 802.11n (HT Greenfield, 150 Mbps, 64-QAM)	X	5.51	67.83	16.85	0.00	150.0	± 9.6 %
		Y	5.46	67.67	16.72		150.0	
		Z	5.52	68.07	17.09		150.0	
10430-AAB	LTE-FDD (OFDMA, 5 MHz, E-TM 3.1)	X	4.33	70.71	18.35	0.00	150.0	± 9.6 %
		Y	4.30	70.83	18.30		150.0	
		Z	4.47	71.91	19.03		150.0	
10431-AAB	LTE-FDD (OFDMA, 10 MHz, E-TM 3.1)	X	4.39	67.75	16.67	0.00	150.0	± 9.6 %
		Y	4.31	67.51	16.45		150.0	
		Z	4.40	68.18	16.99		150.0	
10432-AAB	LTE-FDD (OFDMA, 15 MHz, E-TM 3.1)	X	4.67	67.58	16.68	0.00	150.0	± 9.6 %
		Y	4.60	67.37	16.49		150.0	
		Z	4.68	67.92	16.97		150.0	
10433-AAB	LTE-FDD (OFDMA, 20 MHz, E-TM 3.1)	X	4.91	67.55	16.73	0.00	150.0	± 9.6 %
		Y	4.85	67.35	16.55		150.0	
		Z	4.91	67.83	16.99		150.0	
10434-AAA	W-CDMA (BS Test Model 1, 64 DPCH)	X	4.43	71.53	18.35	0.00	150.0	± 9.6 %
		Y	4.41	71.68	18.29		150.0	
		Z	4.65	73.05	19.14		150.0	
10435-AAC	LTE-TDD (SC-FDMA, 1 RB, 20 MHz, QPSK, UL Subframe=2,3,4,7,8,9)	X	100.00	123.46	32.05	3.23	80.0	± 9.6 %
		Y	100.00	123.05	31.84		80.0	
		Z	100.00	125.84	32.99		80.0	
10447-AAB	LTE-FDD (OFDMA, 5 MHz, E-TM 3.1, Clipping 44%)	X	3.72	67.96	16.21	0.00	150.0	± 9.6 %
		Y	3.62	67.60	15.87		150.0	
		Z	3.76	68.65	16.62		150.0	
10448-AAB	LTE-FDD (OFDMA, 10 MHz, E-TM 3.1, Clipping 44%)	X	4.21	67.53	16.53	0.00	150.0	± 9.6 %
		Y	4.14	67.29	16.31		150.0	
		Z	4.23	67.97	16.87		150.0	
10449-AAB	LTE-FDD (OFDMA, 15 MHz, E-TM 3.1, Clipping 44%)	X	4.47	67.41	16.59	0.00	150.0	± 9.6 %
		Y	4.41	67.19	16.39		150.0	
		Z	4.48	67.77	16.89		150.0	
10450-AAB	LTE-FDD (OFDMA, 20 MHz, E-TM 3.1, Clipping 44%)	X	4.65	67.31	16.59	0.00	150.0	± 9.6 %
		Y	4.60	67.11	16.41		150.0	
		Z	4.67	67.62	16.86		150.0	
10451-AAA	W-CDMA (BS Test Model 1, 64 DPCH, Clipping 44%)	X	3.65	68.30	15.96	0.00	150.0	± 9.6 %
		Y	3.53	67.85	15.54		150.0	
		Z	3.71	69.10	16.39		150.0	
10456-AAA	IEEE 802.11ac WiFi (160MHz, 64-QAM, 99pc duty cycle)	X	6.35	68.37	16.99	0.00	150.0	± 9.6 %
		Y	6.31	68.22	16.86		150.0	
		Z	6.36	68.55	17.18		150.0	
10457-AAA	UMTS-FDD (DC-HSDPA)	X	3.86	65.71	16.31	0.00	150.0	± 9.6 %
		Y	3.83	65.53	16.12		150.0	
		Z	3.88	66.00	16.58		150.0	
10458-AAA	CDMA2000 (1xEV-DO, Rev. B, 2 carriers)	X	4.08	70.87	17.88	0.00	150.0	± 9.6 %
		Y	4.05	70.95	17.73		150.0	
		Z	4.31	72.52	18.68		150.0	
10459-AAA	CDMA2000 (1xEV-DO, Rev. B, 3 carriers)	X	5.10	67.90	18.10	0.00	150.0	± 9.6 %
		Y	5.08	68.13	18.12		150.0	
		Z	5.19	68.77	18.56		150.0	

10460-AAA	UMTS-FDD (WCDMA, AMR)	X	1.28	75.46	20.14	0.00	150.0	± 9.6 %
		Y	1.01	70.79	17.56		150.0	
		Z	2.05	85.40	24.88		150.0	
10461-AAA	LTE-TDD (SC-FDMA, 1 RB, 1.4 MHz, QPSK, UL Subframe=2,3,4,7,8,9)	X	100.00	129.70	34.97	3.29	80.0	± 9.6 %
		Y	100.00	128.65	34.47		80.0	
		Z	100.00	133.57	36.56		80.0	
10462-AAA	LTE-TDD (SC-FDMA, 1 RB, 1.4 MHz, 16-QAM, UL Subframe=2,3,4,7,8,9)	X	100.00	113.45	27.17	3.23	80.0	± 9.6 %
		Y	100.00	112.60	26.79		80.0	
		Z	100.00	115.86	28.09		80.0	
10463-AAA	LTE-TDD (SC-FDMA, 1 RB, 1.4 MHz, 64-QAM, UL Subframe=2,3,4,7,8,9)	X	100.00	110.13	25.59	3.23	80.0	± 9.6 %
		Y	100.00	109.32	25.21		80.0	
		Z	100.00	112.12	26.31		80.0	
10464-AAA	LTE-TDD (SC-FDMA, 1 RB, 3 MHz, QPSK, UL Subframe=2,3,4,7,8,9)	X	100.00	127.95	33.99	3.23	80.0	± 9.6 %
		Y	100.00	126.84	33.46		80.0	
		Z	100.00	131.83	35.57		80.0	
10465-AAA	LTE-TDD (SC-FDMA, 1 RB, 3 MHz, 16-QAM, UL Subframe=2,3,4,7,8,9)	X	100.00	112.94	26.92	3.23	80.0	± 9.6 %
		Y	100.00	112.07	26.53		80.0	
		Z	100.00	115.28	27.81		80.0	
10466-AAA	LTE-TDD (SC-FDMA, 1 RB, 3 MHz, 64-QAM, UL Subframe=2,3,4,7,8,9)	X	100.00	109.63	25.35	3.23	80.0	± 9.6 %
		Y	100.00	108.81	24.97		80.0	
		Z	100.00	111.54	26.04		80.0	
10467-AAC	LTE-TDD (SC-FDMA, 1 RB, 5 MHz, QPSK, UL Subframe=2,3,4,7,8,9)	X	100.00	128.18	34.09	3.23	80.0	± 9.6 %
		Y	100.00	127.07	33.57		80.0	
		Z	100.00	132.10	35.69		80.0	
10468-AAC	LTE-TDD (SC-FDMA, 1 RB, 5 MHz, 16-QAM, UL Subframe=2,3,4,7,8,9)	X	100.00	113.11	27.00	3.23	80.0	± 9.6 %
		Y	100.00	112.25	26.61		80.0	
		Z	100.00	115.49	27.90		80.0	
10469-AAC	LTE-TDD (SC-FDMA, 1 RB, 5 MHz, 64-QAM, UL Subframe=2,3,4,7,8,9)	X	100.00	109.65	25.35	3.23	80.0	± 9.6 %
		Y	100.00	108.83	24.97		80.0	
		Z	100.00	111.57	26.05		80.0	
10470-AAC	LTE-TDD (SC-FDMA, 1 RB, 10 MHz, QPSK, UL Subframe=2,3,4,7,8,9)	X	100.00	128.23	34.10	3.23	80.0	± 9.6 %
		Y	100.00	127.12	33.58		80.0	
		Z	100.00	132.16	35.71		80.0	
10471-AAC	LTE-TDD (SC-FDMA, 1 RB, 10 MHz, 16-QAM, UL Subframe=2,3,4,7,8,9)	X	100.00	113.07	26.97	3.23	80.0	± 9.6 %
		Y	100.00	112.20	26.58		80.0	
		Z	100.00	115.44	27.88		80.0	
10472-AAC	LTE-TDD (SC-FDMA, 1 RB, 10 MHz, 64-QAM, UL Subframe=2,3,4,7,8,9)	X	100.00	109.61	25.32	3.23	80.0	± 9.6 %
		Y	100.00	108.78	24.95		80.0	
		Z	100.00	111.52	26.02		80.0	
10473-AAC	LTE-TDD (SC-FDMA, 1 RB, 15 MHz, QPSK, UL Subframe=2,3,4,7,8,9)	X	100.00	128.20	34.09	3.23	80.0	± 9.6 %
		Y	100.00	127.09	33.57		80.0	
		Z	100.00	132.13	35.70		80.0	
10474-AAC	LTE-TDD (SC-FDMA, 1 RB, 15 MHz, 16-QAM, UL Subframe=2,3,4,7,8,9)	X	100.00	113.08	26.98	3.23	80.0	± 9.6 %
		Y	100.00	112.21	26.58		80.0	
		Z	100.00	115.45	27.88		80.0	
10475-AAC	LTE-TDD (SC-FDMA, 1 RB, 15 MHz, 64-QAM, UL Subframe=2,3,4,7,8,9)	X	100.00	109.62	25.33	3.23	80.0	± 9.6 %
		Y	100.00	108.79	24.95		80.0	
		Z	100.00	111.54	26.02		80.0	

10477-AAC	LTE-TDD (SC-FDMA, 1 RB, 20 MHz, 16-QAM, UL Subframe=2,3,4,7,8,9)	X	100.00	112.91	26.90	3.23	80.0	± 9.6 %
		Y	100.00	112.04	26.50		80.0	
		Z	100.00	115.26	27.79		80.0	
10478-AAC	LTE-TDD (SC-FDMA, 1 RB, 20 MHz, 64-QAM, UL Subframe=2,3,4,7,8,9)	X	100.00	109.57	25.30	3.23	80.0	± 9.6 %
		Y	100.00	108.74	24.93		80.0	
		Z	100.00	111.47	25.99		80.0	
10479-AAA	LTE-TDD (SC-FDMA, 50% RB, 1.4 MHz, QPSK, UL Subframe=2,3,4,7,8,9)	X	93.91	126.96	35.35	3.23	80.0	± 9.6 %
		Y	99.44	126.63	34.89		80.0	
		Z	100.00	129.46	36.10		80.0	
10480-AAA	LTE-TDD (SC-FDMA, 50% RB, 1.4 MHz, 16-QAM, UL Subframe=2,3,4,7,8,9)	X	100.00	118.51	31.10	3.23	80.0	± 9.6 %
		Y	100.00	117.40	30.49		80.0	
		Z	100.00	119.35	31.31		80.0	
10481-AAA	LTE-TDD (SC-FDMA, 50% RB, 1.4 MHz, 64-QAM, UL Subframe=2,3,4,7,8,9)	X	78.24	113.43	29.46	3.23	80.0	± 9.6 %
		Y	80.59	112.78	28.96		80.0	
		Z	100.00	117.55	30.39		80.0	
10482-AAA	LTE-TDD (SC-FDMA, 50% RB, 3 MHz, QPSK, UL Subframe=2,3,4,7,8,9)	X	9.23	86.48	22.53	2.23	80.0	± 9.6 %
		Y	7.26	82.47	20.90		80.0	
		Z	23.40	101.02	26.91		80.0	
10483-AAA	LTE-TDD (SC-FDMA, 50% RB, 3 MHz, 16-QAM, UL Subframe=2,3,4,7,8,9)	X	19.79	94.89	25.20	2.23	80.0	± 9.6 %
		Y	20.06	94.34	24.69		80.0	
		Z	58.67	111.11	29.39		80.0	
10484-AAA	LTE-TDD (SC-FDMA, 50% RB, 3 MHz, 64-QAM, UL Subframe=2,3,4,7,8,9)	X	16.11	91.63	24.24	2.23	80.0	± 9.6 %
		Y	16.01	90.87	23.67		80.0	
		Z	36.85	104.10	27.61		80.0	
10485-AAC	LTE-TDD (SC-FDMA, 50% RB, 5 MHz, QPSK, UL Subframe=2,3,4,7,8,9)	X	8.67	86.19	23.27	2.23	80.0	± 9.6 %
		Y	7.19	82.89	21.92		80.0	
		Z	15.73	96.67	26.75		80.0	
10486-AAC	LTE-TDD (SC-FDMA, 50% RB, 5 MHz, 16-QAM, UL Subframe=2,3,4,7,8,9)	X	5.56	76.17	19.34	2.23	80.0	± 9.6 %
		Y	5.16	74.80	18.58		80.0	
		Z	7.01	80.41	20.99		80.0	
10487-AAC	LTE-TDD (SC-FDMA, 50% RB, 5 MHz, 64-QAM, UL Subframe=2,3,4,7,8,9)	X	5.41	75.40	19.04	2.23	80.0	± 9.6 %
		Y	5.05	74.13	18.31		80.0	
		Z	6.62	79.17	20.53		80.0	
10488-AAC	LTE-TDD (SC-FDMA, 50% RB, 10 MHz, QPSK, UL Subframe=2,3,4,7,8,9)	X	7.17	81.89	22.37	2.23	80.0	± 9.6 %
		Y	6.33	79.62	21.40		80.0	
		Z	9.20	87.01	24.43		80.0	
10489-AAC	LTE-TDD (SC-FDMA, 50% RB, 10 MHz, 16-QAM, UL Subframe=2,3,4,7,8,9)	X	5.21	74.17	19.60	2.23	80.0	± 9.6 %
		Y	4.98	73.27	19.08		80.0	
		Z	5.69	76.33	20.65		80.0	
10490-AAC	LTE-TDD (SC-FDMA, 50% RB, 10 MHz, 64-QAM, UL Subframe=2,3,4,7,8,9)	X	5.23	73.67	19.42	2.23	80.0	± 9.6 %
		Y	5.01	72.86	18.94		80.0	
		Z	5.64	75.63	20.39		80.0	
10491-AAC	LTE-TDD (SC-FDMA, 50% RB, 15 MHz, QPSK, UL Subframe=2,3,4,7,8,9)	X	6.26	77.61	20.92	2.23	80.0	± 9.6 %
		Y	5.79	76.17	20.25		80.0	
		Z	7.08	80.47	22.26		80.0	
10492-AAC	LTE-TDD (SC-FDMA, 50% RB, 15 MHz, 16-QAM, UL Subframe=2,3,4,7,8,9)	X	5.27	72.43	19.16	2.23	80.0	± 9.6 %
		Y	5.10	71.74	18.75		80.0	
		Z	5.50	73.74	19.89		80.0	

10493-AAC	LTE-TDD (SC-FDMA, 50% RB, 15 MHz, 64-QAM, UL Subframe=2,3,4,7,8,9)	X	5.30	72.14	19.05	2.23	80.0	± 9.6 %
		Y	5.14	71.49	18.66		80.0	
		Z	5.50	73.35	19.74		80.0	
10494-AAC	LTE-TDD (SC-FDMA, 50% RB, 20 MHz, QPSK, UL Subframe=2,3,4,7,8,9)	X	7.27	80.12	21.64	2.23	80.0	± 9.6 %
		Y	6.57	78.29	20.87		80.0	
		Z	8.61	83.76	23.24		80.0	
10495-AAC	LTE-TDD (SC-FDMA, 50% RB, 20 MHz, 16-QAM, UL Subframe=2,3,4,7,8,9)	X	5.40	73.08	19.42	2.23	80.0	± 9.6 %
		Y	5.20	72.30	18.98		80.0	
		Z	5.65	74.45	20.19		80.0	
10496-AAC	LTE-TDD (SC-FDMA, 50% RB, 20 MHz, 64-QAM, UL Subframe=2,3,4,7,8,9)	X	5.39	72.50	19.22	2.23	80.0	± 9.6 %
		Y	5.21	71.81	18.82		80.0	
		Z	5.59	73.72	19.93		80.0	
10497-AAA	LTE-TDD (SC-FDMA, 100% RB, 1.4 MHz, QPSK, UL Subframe=2,3,4,7,8,9)	X	6.99	81.81	20.14	2.23	80.0	± 9.6 %
		Y	5.33	77.57	18.31		80.0	
		Z	18.22	95.35	24.20		80.0	
10498-AAA	LTE-TDD (SC-FDMA, 100% RB, 1.4 MHz, 16-QAM, UL Subframe=2,3,4,7,8,9)	X	3.86	70.78	15.09	2.23	80.0	± 9.6 %
		Y	3.14	67.94	13.56		80.0	
		Z	4.75	73.71	16.05		80.0	
10499-AAA	LTE-TDD (SC-FDMA, 100% RB, 1.4 MHz, 64-QAM, UL Subframe=2,3,4,7,8,9)	X	3.66	69.79	14.55	2.23	80.0	± 9.6 %
		Y	2.98	67.04	13.03		80.0	
		Z	4.25	71.98	15.23		80.0	
10500-AAA	LTE-TDD (SC-FDMA, 100% RB, 3 MHz, QPSK, UL Subframe=2,3,4,7,8,9)	X	7.54	83.45	22.61	2.23	80.0	± 9.6 %
		Y	6.51	80.82	21.48		80.0	
		Z	11.15	90.79	25.28		80.0	
10501-AAA	LTE-TDD (SC-FDMA, 100% RB, 3 MHz, 16-QAM, UL Subframe=2,3,4,7,8,9)	X	5.37	75.18	19.36	2.23	80.0	± 9.6 %
		Y	5.06	74.08	18.72		80.0	
		Z	6.29	78.41	20.72		80.0	
10502-AAA	LTE-TDD (SC-FDMA, 100% RB, 3 MHz, 64-QAM, UL Subframe=2,3,4,7,8,9)	X	5.36	74.77	19.16	2.23	80.0	± 9.6 %
		Y	5.08	73.74	18.54		80.0	
		Z	6.22	77.81	20.44		80.0	
10503-AAC	LTE-TDD (SC-FDMA, 100% RB, 5 MHz, QPSK, UL Subframe=2,3,4,7,8,9)	X	7.07	81.64	22.27	2.23	80.0	± 9.6 %
		Y	6.24	79.38	21.29		80.0	
		Z	9.02	86.67	24.31		80.0	
10504-AAC	LTE-TDD (SC-FDMA, 100% RB, 5 MHz, 16-QAM, UL Subframe=2,3,4,7,8,9)	X	5.19	74.08	19.55	2.23	80.0	± 9.6 %
		Y	4.95	73.17	19.03		80.0	
		Z	5.65	76.22	20.59		80.0	
10505-AAC	LTE-TDD (SC-FDMA, 100% RB, 5 MHz, 64-QAM, UL Subframe=2,3,4,7,8,9)	X	5.20	73.58	19.37	2.23	80.0	± 9.6 %
		Y	4.99	72.76	18.88		80.0	
		Z	5.61	75.52	20.33		80.0	
10506-AAC	LTE-TDD (SC-FDMA, 100% RB, 10 MHz, QPSK, UL Subframe=2,3,4,7,8,9)	X	7.20	79.95	21.57	2.23	80.0	± 9.6 %
		Y	6.51	78.12	20.79		80.0	
		Z	8.50	83.53	23.15		80.0	
10507-AAC	LTE-TDD (SC-FDMA, 100% RB, 10 MHz, 16-QAM, UL Subframe=2,3,4,7,8,9)	X	5.38	73.02	19.39	2.23	80.0	± 9.6 %
		Y	5.18	72.24	18.95		80.0	
		Z	5.63	74.38	20.16		80.0	

10508-AAC	LTE-TDD (SC-FDMA, 100% RB, 10 MHz, 64-QAM, UL Subframe=2,3,4,7,8,9)	X	5.37	72.44	19.19	2.23	80.0	± 9.6 %
		Y	5.19	71.74	18.78		80.0	
		Z	5.57	73.64	19.89		80.0	
10509-AAC	LTE-TDD (SC-FDMA, 100% RB, 15 MHz, QPSK, UL Subframe=2,3,4,7,8,9)	X	6.63	76.44	20.27	2.23	80.0	± 9.6 %
		Y	6.24	75.29	19.74		80.0	
		Z	7.26	78.60	21.35		80.0	
10510-AAC	LTE-TDD (SC-FDMA, 100% RB, 15 MHz, 16-QAM, UL Subframe=2,3,4,7,8,9)	X	5.71	72.04	19.05	2.23	80.0	± 9.6 %
		Y	5.54	71.40	18.69		80.0	
		Z	5.85	72.94	19.63		80.0	
10511-AAC	LTE-TDD (SC-FDMA, 100% RB, 15 MHz, 64-QAM, UL Subframe=2,3,4,7,8,9)	X	5.70	71.59	18.91	2.23	80.0	± 9.6 %
		Y	5.55	71.01	18.58		80.0	
		Z	5.81	72.41	19.45		80.0	
10512-AAC	LTE-TDD (SC-FDMA, 100% RB, 20 MHz, QPSK, UL Subframe=2,3,4,7,8,9)	X	7.58	79.28	21.16	2.23	80.0	± 9.6 %
		Y	6.93	77.65	20.47		80.0	
		Z	8.72	82.28	22.52		80.0	
10513-AAC	LTE-TDD (SC-FDMA, 100% RB, 20 MHz, 16-QAM, UL Subframe=2,3,4,7,8,9)	X	5.70	72.66	19.29	2.23	80.0	± 9.6 %
		Y	5.50	71.92	18.89		80.0	
		Z	5.86	73.67	19.92		80.0	
10514-AAC	LTE-TDD (SC-FDMA, 100% RB, 20 MHz, 64-QAM, UL Subframe=2,3,4,7,8,9)	X	5.60	71.96	19.07	2.23	80.0	± 9.6 %
		Y	5.44	71.30	18.70		80.0	
		Z	5.74	72.84	19.64		80.0	
10515-AAA	IEEE 802.11b WiFi 2.4 GHz (DSSS, 2 Mbps, 99pc duty cycle)	X	1.01	64.72	16.07	0.00	150.0	± 9.6 %
		Y	0.98	63.83	15.25		150.0	
		Z	1.07	66.15	17.35		150.0	
10516-AAA	IEEE 802.11b WiFi 2.4 GHz (DSSS, 5.5 Mbps, 99pc duty cycle)	X	2.33	97.38	28.67	0.00	150.0	± 9.6 %
		Y	0.83	77.16	20.49		150.0	
		Z	100.00	177.66	50.48		150.0	
10517-AAA	IEEE 802.11b WiFi 2.4 GHz (DSSS, 11 Mbps, 99pc duty cycle)	X	0.94	68.55	17.77	0.00	150.0	± 9.6 %
		Y	0.86	66.46	16.26		150.0	
		Z	1.08	72.03	20.16		150.0	
10518-AAA	IEEE 802.11a/h WiFi 5 GHz (OFDM, 9 Mbps, 99pc duty cycle)	X	4.65	67.18	16.56	0.00	150.0	± 9.6 %
		Y	4.60	66.99	16.39		150.0	
		Z	4.66	67.49	16.83		150.0	
10519-AAA	IEEE 802.11a/h WiFi 5 GHz (OFDM, 12 Mbps, 99pc duty cycle)	X	4.86	67.45	16.69	0.00	150.0	± 9.6 %
		Y	4.80	67.25	16.51		150.0	
		Z	4.86	67.73	16.95		150.0	
10520-AAA	IEEE 802.11a/h WiFi 5 GHz (OFDM, 18 Mbps, 99pc duty cycle)	X	4.71	67.43	16.62	0.00	150.0	± 9.6 %
		Y	4.65	67.22	16.44		150.0	
		Z	4.72	67.74	16.89		150.0	
10521-AAA	IEEE 802.11a/h WiFi 5 GHz (OFDM, 24 Mbps, 99pc duty cycle)	X	4.65	67.44	16.61	0.00	150.0	± 9.6 %
		Y	4.58	67.22	16.43		150.0	
		Z	4.65	67.75	16.89		150.0	
10522-AAA	IEEE 802.11a/h WiFi 5 GHz (OFDM, 36 Mbps, 99pc duty cycle)	X	4.70	67.47	16.67	0.00	150.0	± 9.6 %
		Y	4.64	67.28	16.50		150.0	
		Z	4.71	67.82	16.97		150.0	

10523-AAA	IEEE 802.11a/h WiFi 5 GHz (OFDM, 48 Mbps, 99pc duty cycle)	X	4.57	67.35	16.52	0.00	150.0	± 9.6 %
		Y	4.51	67.15	16.34		150.0	
		Z	4.59	67.69	16.82		150.0	
10524-AAA	IEEE 802.11a/h WiFi 5 GHz (OFDM, 54 Mbps, 99pc duty cycle)	X	4.65	67.41	16.65	0.00	150.0	± 9.6 %
		Y	4.58	67.21	16.47		150.0	
		Z	4.65	67.74	16.94		150.0	
10525-AAA	IEEE 802.11ac WiFi (20MHz, MCS0, 99pc duty cycle)	X	4.62	66.43	16.22	0.00	150.0	± 9.6 %
		Y	4.56	66.24	16.05		150.0	
		Z	4.64	66.77	16.51		150.0	
10526-AAA	IEEE 802.11ac WiFi (20MHz, MCS1, 99pc duty cycle)	X	4.81	66.84	16.38	0.00	150.0	± 9.6 %
		Y	4.74	66.63	16.20		150.0	
		Z	4.82	67.17	16.66		150.0	
10527-AAA	IEEE 802.11ac WiFi (20MHz, MCS2, 99pc duty cycle)	X	4.73	66.81	16.33	0.00	150.0	± 9.6 %
		Y	4.66	66.59	16.15		150.0	
		Z	4.74	67.15	16.62		150.0	
10528-AAA	IEEE 802.11ac WiFi (20MHz, MCS3, 99pc duty cycle)	X	4.75	66.83	16.36	0.00	150.0	± 9.6 %
		Y	4.68	66.61	16.18		150.0	
		Z	4.76	67.16	16.65		150.0	
10529-AAA	IEEE 802.11ac WiFi (20MHz, MCS4, 99pc duty cycle)	X	4.75	66.83	16.36	0.00	150.0	± 9.6 %
		Y	4.68	66.61	16.18		150.0	
		Z	4.76	67.16	16.65		150.0	
10531-AAA	IEEE 802.11ac WiFi (20MHz, MCS6, 99pc duty cycle)	X	4.75	66.98	16.39	0.00	150.0	± 9.6 %
		Y	4.68	66.74	16.20		150.0	
		Z	4.76	67.31	16.68		150.0	
10532-AAA	IEEE 802.11ac WiFi (20MHz, MCS7, 99pc duty cycle)	X	4.60	66.84	16.33	0.00	150.0	± 9.6 %
		Y	4.53	66.59	16.14		150.0	
		Z	4.62	67.17	16.63		150.0	
10533-AAA	IEEE 802.11ac WiFi (20MHz, MCS8, 99pc duty cycle)	X	4.76	66.86	16.34	0.00	150.0	± 9.6 %
		Y	4.69	66.65	16.17		150.0	
		Z	4.77	67.21	16.64		150.0	
10534-AAA	IEEE 802.11ac WiFi (40MHz, MCS0, 99pc duty cycle)	X	5.26	66.91	16.38	0.00	150.0	± 9.6 %
		Y	5.21	66.72	16.23		150.0	
		Z	5.28	67.16	16.62		150.0	
10535-AAA	IEEE 802.11ac WiFi (40MHz, MCS1, 99pc duty cycle)	X	5.33	67.07	16.45	0.00	150.0	± 9.6 %
		Y	5.28	66.90	16.31		150.0	
		Z	5.35	67.36	16.71		150.0	
10536-AAA	IEEE 802.11ac WiFi (40MHz, MCS2, 99pc duty cycle)	X	5.20	67.05	16.42	0.00	150.0	± 9.6 %
		Y	5.15	66.85	16.27		150.0	
		Z	5.22	67.33	16.68		150.0	
10537-AAA	IEEE 802.11ac WiFi (40MHz, MCS3, 99pc duty cycle)	X	5.27	67.02	16.41	0.00	150.0	± 9.6 %
		Y	5.21	66.82	16.25		150.0	
		Z	5.28	67.28	16.66		150.0	
10538-AAA	IEEE 802.11ac WiFi (40MHz, MCS4, 99pc duty cycle)	X	5.37	67.07	16.47	0.00	150.0	± 9.6 %
		Y	5.31	66.86	16.31		150.0	
		Z	5.37	67.29	16.70		150.0	
10540-AAA	IEEE 802.11ac WiFi (40MHz, MCS6, 99pc duty cycle)	X	5.28	67.05	16.48	0.00	150.0	± 9.6 %
		Y	5.23	66.86	16.33		150.0	
		Z	5.30	67.32	16.73		150.0	

10541-AAA	IEEE 802.11ac WiFi (40MHz, MCS7, 99pc duty cycle)	X	5.26	66.92	16.41	0.00	150.0	± 9.6 %
		Y	5.20	66.72	16.25		150.0	
		Z	5.27	67.16	16.65		150.0	
10542-AAA	IEEE 802.11ac WiFi (40MHz, MCS8, 99pc duty cycle)	X	5.41	66.98	16.45	0.00	150.0	± 9.6 %
		Y	5.36	66.79	16.30		150.0	
		Z	5.42	67.21	16.68		150.0	
10543-AAA	IEEE 802.11ac WiFi (40MHz, MCS9, 99pc duty cycle)	X	5.49	67.00	16.48	0.00	150.0	± 9.6 %
		Y	5.44	66.84	16.34		150.0	
		Z	5.50	67.25	16.72		150.0	
10544-AAA	IEEE 802.11ac WiFi (80MHz, MCS0, 99pc duty cycle)	X	5.55	66.99	16.34	0.00	150.0	± 9.6 %
		Y	5.51	66.81	16.21		150.0	
		Z	5.58	67.22	16.57		150.0	
10545-AAA	IEEE 802.11ac WiFi (80MHz, MCS1, 99pc duty cycle)	X	5.77	67.45	16.52	0.00	150.0	± 9.6 %
		Y	5.73	67.28	16.39		150.0	
		Z	5.80	67.70	16.76		150.0	
10546-AAA	IEEE 802.11ac WiFi (80MHz, MCS2, 99pc duty cycle)	X	5.65	67.27	16.45	0.00	150.0	± 9.6 %
		Y	5.59	67.07	16.30		150.0	
		Z	5.66	67.48	16.67		150.0	
10547-AAA	IEEE 802.11ac WiFi (80MHz, MCS3, 99pc duty cycle)	X	5.74	67.36	16.48	0.00	150.0	± 9.6 %
		Y	5.67	67.13	16.32		150.0	
		Z	5.73	67.52	16.67		150.0	
10548-AAA	IEEE 802.11ac WiFi (80MHz, MCS4, 99pc duty cycle)	X	6.09	68.60	17.08	0.00	150.0	± 9.6 %
		Y	6.02	68.35	16.90		150.0	
		Z	6.09	68.78	17.28		150.0	
10550-AAA	IEEE 802.11ac WiFi (80MHz, MCS6, 99pc duty cycle)	X	5.66	67.23	16.44	0.00	150.0	± 9.6 %
		Y	5.61	67.06	16.30		150.0	
		Z	5.68	67.48	16.67		150.0	
10551-AAA	IEEE 802.11ac WiFi (80MHz, MCS7, 99pc duty cycle)	X	5.67	67.29	16.43	0.00	150.0	± 9.6 %
		Y	5.62	67.09	16.28		150.0	
		Z	5.69	67.51	16.65		150.0	
10552-AAA	IEEE 802.11ac WiFi (80MHz, MCS8, 99pc duty cycle)	X	5.58	67.06	16.32	0.00	150.0	± 9.6 %
		Y	5.53	66.87	16.18		150.0	
		Z	5.59	67.28	16.55		150.0	
10553-AAA	IEEE 802.11ac WiFi (80MHz, MCS9, 99pc duty cycle)	X	5.67	67.11	16.38	0.00	150.0	± 9.6 %
		Y	5.61	66.92	16.23		150.0	
		Z	5.68	67.31	16.59		150.0	
10554-AAB	IEEE 802.11ac WiFi (160MHz, MCS0, 99pc duty cycle)	X	5.96	67.36	16.43	0.00	150.0	± 9.6 %
		Y	5.92	67.18	16.30		150.0	
		Z	5.99	67.56	16.64		150.0	
10555-AAB	IEEE 802.11ac WiFi (160MHz, MCS1, 99pc duty cycle)	X	6.11	67.70	16.57	0.00	150.0	± 9.6 %
		Y	6.06	67.52	16.44		150.0	
		Z	6.13	67.91	16.79		150.0	
10556-AAB	IEEE 802.11ac WiFi (160MHz, MCS2, 99pc duty cycle)	X	6.13	67.73	16.58	0.00	150.0	± 9.6 %
		Y	6.08	67.56	16.45		150.0	
		Z	6.15	67.95	16.80		150.0	
10557-AAB	IEEE 802.11ac WiFi (160MHz, MCS3, 99pc duty cycle)	X	6.10	67.66	16.57	0.00	150.0	± 9.6 %
		Y	6.05	67.47	16.43		150.0	
		Z	6.12	67.85	16.77		150.0	

10558-AAB	IEEE 802.11ac WiFi (160MHz, MCS4, 99pc duty cycle)	X	6.16	67.86	16.68	0.00	150.0	± 9.6 %
		Y	6.11	67.65	16.54		150.0	
		Z	6.17	68.04	16.88		150.0	
10560-AAB	IEEE 802.11ac WiFi (160MHz, MCS6, 99pc duty cycle)	X	6.15	67.67	16.63	0.00	150.0	± 9.6 %
		Y	6.09	67.47	16.48		150.0	
		Z	6.16	67.84	16.82		150.0	
10561-AAB	IEEE 802.11ac WiFi (160MHz, MCS7, 99pc duty cycle)	X	6.07	67.65	16.66	0.00	150.0	± 9.6 %
		Y	6.02	67.45	16.51		150.0	
		Z	6.08	67.84	16.86		150.0	
10562-AAB	IEEE 802.11ac WiFi (160MHz, MCS8, 99pc duty cycle)	X	6.23	68.16	16.92	0.00	150.0	± 9.6 %
		Y	6.17	67.92	16.75		150.0	
		Z	6.23	68.31	17.10		150.0	
10563-AAB	IEEE 802.11ac WiFi (160MHz, MCS9, 99pc duty cycle)	X	6.62	68.85	17.21	0.00	150.0	± 9.6 %
		Y	6.53	68.57	17.03		150.0	
		Z	6.57	68.88	17.33		150.0	
10564-AAA	IEEE 802.11g WiFi 2.4 GHz (DSSS-OFDM, 9 Mbps, 99pc duty cycle)	X	4.99	67.30	16.74	0.46	150.0	± 9.6 %
		Y	4.94	67.11	16.57		150.0	
		Z	5.00	67.55	16.97		150.0	
10565-AAA	IEEE 802.11g WiFi 2.4 GHz (DSSS-OFDM, 12 Mbps, 99pc duty cycle)	X	5.24	67.74	17.04	0.46	150.0	± 9.6 %
		Y	5.18	67.56	16.88		150.0	
		Z	5.23	67.98	17.27		150.0	
10566-AAA	IEEE 802.11g WiFi 2.4 GHz (DSSS-OFDM, 18 Mbps, 99pc duty cycle)	X	5.08	67.63	16.89	0.46	150.0	± 9.6 %
		Y	5.01	67.42	16.71		150.0	
		Z	5.07	67.88	17.12		150.0	
10567-AAA	IEEE 802.11g WiFi 2.4 GHz (DSSS-OFDM, 24 Mbps, 99pc duty cycle)	X	5.10	67.97	17.19	0.46	150.0	± 9.6 %
		Y	5.04	67.79	17.04		150.0	
		Z	5.10	68.24	17.45		150.0	
10568-AAA	IEEE 802.11g WiFi 2.4 GHz (DSSS-OFDM, 36 Mbps, 99pc duty cycle)	X	5.00	67.45	16.70	0.46	150.0	± 9.6 %
		Y	4.94	67.23	16.50		150.0	
		Z	5.00	67.71	16.93		150.0	
10569-AAA	IEEE 802.11g WiFi 2.4 GHz (DSSS-OFDM, 48 Mbps, 99pc duty cycle)	X	5.04	68.01	17.22	0.46	150.0	± 9.6 %
		Y	4.99	67.86	17.09		150.0	
		Z	5.05	68.33	17.51		150.0	
10570-AAA	IEEE 802.11g WiFi 2.4 GHz (DSSS-OFDM, 54 Mbps, 99pc duty cycle)	X	5.09	67.88	17.18	0.46	150.0	± 9.6 %
		Y	5.03	67.72	17.03		150.0	
		Z	5.09	68.17	17.44		150.0	
10571-AAA	IEEE 802.11b WiFi 2.4 GHz (DSSS, 1 Mbps, 90pc duty cycle)	X	1.42	67.86	17.70	0.46	130.0	± 9.6 %
		Y	1.36	66.76	16.84		130.0	
		Z	1.50	69.45	18.96		130.0	
10572-AAA	IEEE 802.11b WiFi 2.4 GHz (DSSS, 2 Mbps, 90pc duty cycle)	X	1.46	68.71	18.17	0.46	130.0	± 9.6 %
		Y	1.39	67.51	17.26		130.0	
		Z	1.55	70.54	19.54		130.0	
10573-AAA	IEEE 802.11b WiFi 2.4 GHz (DSSS, 5.5 Mbps, 90pc duty cycle)	X	100.00	149.83	40.32	0.46	130.0	± 9.6 %
		Y	34.76	128.40	34.67		130.0	
		Z	100.00	158.26	43.98		130.0	
10574-AAA	IEEE 802.11b WiFi 2.4 GHz (DSSS, 11 Mbps, 90pc duty cycle)	X	2.10	79.47	22.96	0.46	130.0	± 9.6 %
		Y	1.81	76.00	21.13		130.0	
		Z	2.81	86.47	26.37		130.0	

10575-AAA	IEEE 802.11g WiFi 2.4 GHz (DSSS-OFDM, 6 Mbps, 90pc duty cycle)	X	4.81	67.17	16.85	0.46	130.0	± 9.6 %
		Y	4.76	67.00	16.68		130.0	
		Z	4.81	67.43	17.09		130.0	
10576-AAA	IEEE 802.11g WiFi 2.4 GHz (DSSS-OFDM, 9 Mbps, 90pc duty cycle)	X	4.83	67.32	16.90	0.46	130.0	± 9.6 %
		Y	4.78	67.16	16.74		130.0	
		Z	4.83	67.60	17.15		130.0	
10577-AAA	IEEE 802.11g WiFi 2.4 GHz (DSSS-OFDM, 12 Mbps, 90pc duty cycle)	X	5.05	67.62	17.07	0.46	130.0	± 9.6 %
		Y	5.00	67.45	16.91		130.0	
		Z	5.04	67.88	17.30		130.0	
10578-AAA	IEEE 802.11g WiFi 2.4 GHz (DSSS-OFDM, 18 Mbps, 90pc duty cycle)	X	4.95	67.78	17.16	0.46	130.0	± 9.6 %
		Y	4.89	67.62	17.01		130.0	
		Z	4.94	68.07	17.42		130.0	
10579-AAA	IEEE 802.11g WiFi 2.4 GHz (DSSS-OFDM, 24 Mbps, 90pc duty cycle)	X	4.74	67.23	16.58	0.46	130.0	± 9.6 %
		Y	4.67	66.99	16.37		130.0	
		Z	4.73	67.46	16.81		130.0	
10580-AAA	IEEE 802.11g WiFi 2.4 GHz (DSSS-OFDM, 36 Mbps, 90pc duty cycle)	X	4.78	67.23	16.60	0.46	130.0	± 9.6 %
		Y	4.72	67.00	16.39		130.0	
		Z	4.77	67.49	16.83		130.0	
10581-AAA	IEEE 802.11g WiFi 2.4 GHz (DSSS-OFDM, 48 Mbps, 90pc duty cycle)	X	4.85	67.87	17.12	0.46	130.0	± 9.6 %
		Y	4.80	67.69	16.96		130.0	
		Z	4.85	68.17	17.40		130.0	
10582-AAA	IEEE 802.11g WiFi 2.4 GHz (DSSS-OFDM, 54 Mbps, 90pc duty cycle)	X	4.69	67.03	16.41	0.46	130.0	± 9.6 %
		Y	4.62	66.76	16.17		130.0	
		Z	4.67	67.25	16.62		130.0	
10583-AAA	IEEE 802.11a/h WiFi 5 GHz (OFDM, 6 Mbps, 90pc duty cycle)	X	4.81	67.17	16.85	0.46	130.0	± 9.6 %
		Y	4.76	67.00	16.68		130.0	
		Z	4.81	67.43	17.09		130.0	
10584-AAA	IEEE 802.11a/h WiFi 5 GHz (OFDM, 9 Mbps, 90pc duty cycle)	X	4.83	67.32	16.90	0.46	130.0	± 9.6 %
		Y	4.78	67.16	16.74		130.0	
		Z	4.83	67.60	17.15		130.0	
10585-AAA	IEEE 802.11a/h WiFi 5 GHz (OFDM, 12 Mbps, 90pc duty cycle)	X	5.05	67.62	17.07	0.46	130.0	± 9.6 %
		Y	5.00	67.45	16.91		130.0	
		Z	5.04	67.88	17.30		130.0	
10586-AAA	IEEE 802.11a/h WiFi 5 GHz (OFDM, 18 Mbps, 90pc duty cycle)	X	4.95	67.78	17.16	0.46	130.0	± 9.6 %
		Y	4.89	67.62	17.01		130.0	
		Z	4.94	68.07	17.42		130.0	
10587-AAA	IEEE 802.11a/h WiFi 5 GHz (OFDM, 24 Mbps, 90pc duty cycle)	X	4.74	67.23	16.58	0.46	130.0	± 9.6 %
		Y	4.67	66.99	16.37		130.0	
		Z	4.73	67.46	16.81		130.0	
10588-AAA	IEEE 802.11a/h WiFi 5 GHz (OFDM, 36 Mbps, 90pc duty cycle)	X	4.78	67.23	16.60	0.46	130.0	± 9.6 %
		Y	4.72	67.00	16.39		130.0	
		Z	4.77	67.49	16.83		130.0	
10589-AAA	IEEE 802.11a/h WiFi 5 GHz (OFDM, 48 Mbps, 90pc duty cycle)	X	4.85	67.87	17.12	0.46	130.0	± 9.6 %
		Y	4.80	67.69	16.96		130.0	
		Z	4.85	68.17	17.40		130.0	
10590-AAA	IEEE 802.11a/h WiFi 5 GHz (OFDM, 54 Mbps, 90pc duty cycle)	X	4.69	67.03	16.41	0.46	130.0	± 9.6 %
		Y	4.62	66.76	16.17		130.0	
		Z	4.67	67.25	16.62		130.0	

10591-AAA	IEEE 802.11n (HT Mixed, 20MHz, MCS0, 90pc duty cycle)	X	4.95	67.19	16.92	0.46	130.0	± 9.6 %
		Y	4.91	67.04	16.76		130.0	
		Z	4.95	67.44	17.15		130.0	
10592-AAA	IEEE 802.11n (HT Mixed, 20MHz, MCS1, 90pc duty cycle)	X	5.12	67.54	17.04	0.46	130.0	± 9.6 %
		Y	5.07	67.38	16.89		130.0	
		Z	5.11	67.79	17.28		130.0	
10593-AAA	IEEE 802.11n (HT Mixed, 20MHz, MCS2, 90pc duty cycle)	X	5.05	67.49	16.96	0.46	130.0	± 9.6 %
		Y	4.99	67.31	16.79		130.0	
		Z	5.04	67.73	17.18		130.0	
10594-AAA	IEEE 802.11n (HT Mixed, 20MHz, MCS3, 90pc duty cycle)	X	5.10	67.63	17.09	0.46	130.0	± 9.6 %
		Y	5.05	67.46	16.93		130.0	
		Z	5.09	67.88	17.32		130.0	
10595-AAA	IEEE 802.11n (HT Mixed, 20MHz, MCS4, 90pc duty cycle)	X	5.07	67.61	17.00	0.46	130.0	± 9.6 %
		Y	5.02	67.43	16.84		130.0	
		Z	5.06	67.86	17.23		130.0	
10596-AAA	IEEE 802.11n (HT Mixed, 20MHz, MCS5, 90pc duty cycle)	X	5.02	67.63	17.02	0.46	130.0	± 9.6 %
		Y	4.96	67.44	16.85		130.0	
		Z	5.01	67.89	17.26		130.0	
10597-AAA	IEEE 802.11n (HT Mixed, 20MHz, MCS6, 90pc duty cycle)	X	4.97	67.56	16.92	0.46	130.0	± 9.6 %
		Y	4.91	67.36	16.74		130.0	
		Z	4.96	67.81	17.15		130.0	
10598-AAA	IEEE 802.11n (HT Mixed, 20MHz, MCS7, 90pc duty cycle)	X	4.94	67.77	17.16	0.46	130.0	± 9.6 %
		Y	4.89	67.59	16.99		130.0	
		Z	4.94	68.03	17.40		130.0	
10599-AAA	IEEE 802.11n (HT Mixed, 40MHz, MCS0, 90pc duty cycle)	X	5.62	67.74	17.10	0.46	130.0	± 9.6 %
		Y	5.58	67.58	16.96		130.0	
		Z	5.62	67.93	17.30		130.0	
10600-AAA	IEEE 802.11n (HT Mixed, 40MHz, MCS1, 90pc duty cycle)	X	5.83	68.39	17.40	0.46	130.0	± 9.6 %
		Y	5.77	68.19	17.24		130.0	
		Z	5.81	68.54	17.58		130.0	
10601-AAA	IEEE 802.11n (HT Mixed, 40MHz, MCS2, 90pc duty cycle)	X	5.68	68.01	17.22	0.46	130.0	± 9.6 %
		Y	5.63	67.84	17.08		130.0	
		Z	5.67	68.19	17.42		130.0	
10602-AAA	IEEE 802.11n (HT Mixed, 40MHz, MCS3, 90pc duty cycle)	X	5.76	68.01	17.15	0.46	130.0	± 9.6 %
		Y	5.72	67.84	17.00		130.0	
		Z	5.76	68.21	17.35		130.0	
10603-AAA	IEEE 802.11n (HT Mixed, 40MHz, MCS4, 90pc duty cycle)	X	5.84	68.27	17.39	0.46	130.0	± 9.6 %
		Y	5.79	68.13	17.27		130.0	
		Z	5.83	68.48	17.61		130.0	
10604-AAA	IEEE 802.11n (HT Mixed, 40MHz, MCS5, 90pc duty cycle)	X	5.62	67.70	17.10	0.46	130.0	± 9.6 %
		Y	5.58	67.54	16.96		130.0	
		Z	5.62	67.88	17.30		130.0	
10605-AAA	IEEE 802.11n (HT Mixed, 40MHz, MCS6, 90pc duty cycle)	X	5.75	68.10	17.31	0.46	130.0	± 9.6 %
		Y	5.71	67.96	17.18		130.0	
		Z	5.76	68.33	17.53		130.0	
10606-AAA	IEEE 802.11n (HT Mixed, 40MHz, MCS7, 90pc duty cycle)	X	5.51	67.50	16.88	0.46	130.0	± 9.6 %
		Y	5.46	67.32	16.72		130.0	
		Z	5.51	67.70	17.09		130.0	

10607-AAA	IEEE 802.11ac WiFi (20MHz, MCS0, 90pc duty cycle)	X	4.79	66.50	16.53	0.46	130.0	± 9.6 %
		Y	4.74	66.34	16.38		130.0	
		Z	4.80	66.80	16.80		130.0	
10608-AAA	IEEE 802.11ac WiFi (20MHz, MCS1, 90pc duty cycle)	X	5.00	66.94	16.70	0.46	130.0	± 9.6 %
		Y	4.94	66.76	16.55		130.0	
		Z	5.00	67.23	16.97		130.0	
10609-AAA	IEEE 802.11ac WiFi (20MHz, MCS2, 90pc duty cycle)	X	4.89	66.83	16.57	0.46	130.0	± 9.6 %
		Y	4.83	66.63	16.40		130.0	
		Z	4.89	67.12	16.83		130.0	
10610-AAA	IEEE 802.11ac WiFi (20MHz, MCS3, 90pc duty cycle)	X	4.94	66.97	16.72	0.46	130.0	± 9.6 %
		Y	4.88	66.78	16.56		130.0	
		Z	4.94	67.26	16.98		130.0	
10611-AAA	IEEE 802.11ac WiFi (20MHz, MCS4, 90pc duty cycle)	X	4.86	66.80	16.58	0.46	130.0	± 9.6 %
		Y	4.80	66.60	16.41		130.0	
		Z	4.86	67.09	16.84		130.0	
10612-AAA	IEEE 802.11ac WiFi (20MHz, MCS5, 90pc duty cycle)	X	4.88	66.99	16.65	0.46	130.0	± 9.6 %
		Y	4.81	66.78	16.47		130.0	
		Z	4.88	67.29	16.92		130.0	
10613-AAA	IEEE 802.11ac WiFi (20MHz, MCS6, 90pc duty cycle)	X	4.89	66.91	16.55	0.46	130.0	± 9.6 %
		Y	4.82	66.68	16.36		130.0	
		Z	4.89	67.18	16.80		130.0	
10614-AAA	IEEE 802.11ac WiFi (20MHz, MCS7, 90pc duty cycle)	X	4.82	67.04	16.74	0.46	130.0	± 9.6 %
		Y	4.76	66.84	16.58		130.0	
		Z	4.82	67.34	17.02		130.0	
10615-AAA	IEEE 802.11ac WiFi (20MHz, MCS8, 90pc duty cycle)	X	4.87	66.66	16.39	0.46	130.0	± 9.6 %
		Y	4.80	66.45	16.20		130.0	
		Z	4.87	66.94	16.64		130.0	
10616-AAA	IEEE 802.11ac WiFi (40MHz, MCS0, 90pc duty cycle)	X	5.44	67.00	16.70	0.46	130.0	± 9.6 %
		Y	5.39	66.83	16.57		130.0	
		Z	5.45	67.22	16.93		130.0	
10617-AAA	IEEE 802.11ac WiFi (40MHz, MCS1, 90pc duty cycle)	X	5.50	67.14	16.74	0.46	130.0	± 9.6 %
		Y	5.47	67.01	16.63		130.0	
		Z	5.53	67.43	17.00		130.0	
10618-AAA	IEEE 802.11ac WiFi (40MHz, MCS2, 90pc duty cycle)	X	5.40	67.20	16.79	0.46	130.0	± 9.6 %
		Y	5.35	67.03	16.65		130.0	
		Z	5.41	67.44	17.03		130.0	
10619-AAA	IEEE 802.11ac WiFi (40MHz, MCS3, 90pc duty cycle)	X	5.43	67.05	16.65	0.46	130.0	± 9.6 %
		Y	5.38	66.88	16.51		130.0	
		Z	5.43	67.28	16.89		130.0	
10620-AAA	IEEE 802.11ac WiFi (40MHz, MCS4, 90pc duty cycle)	X	5.53	67.12	16.74	0.46	130.0	± 9.6 %
		Y	5.47	66.91	16.58		130.0	
		Z	5.52	67.29	16.94		130.0	
10621-AAA	IEEE 802.11ac WiFi (40MHz, MCS5, 90pc duty cycle)	X	5.50	67.12	16.84	0.46	130.0	± 9.6 %
		Y	5.45	66.97	16.72		130.0	
		Z	5.50	67.35	17.07		130.0	
10622-AAA	IEEE 802.11ac WiFi (40MHz, MCS6, 90pc duty cycle)	X	5.51	67.30	16.93	0.46	130.0	± 9.6 %
		Y	5.47	67.17	16.81		130.0	
		Z	5.53	67.57	17.18		130.0	

10623-AAA	IEEE 802.11ac WiFi (40MHz, MCS7, 90pc duty cycle)	X	5.39	66.87	16.60	0.46	130.0	± 9.6 %
		Y	5.34	66.69	16.45		130.0	
		Z	5.40	67.09	16.83		130.0	
10624-AAA	IEEE 802.11ac WiFi (40MHz, MCS8, 90pc duty cycle)	X	5.59	67.05	16.75	0.46	130.0	± 9.6 %
		Y	5.54	66.89	16.62		130.0	
		Z	5.59	67.27	16.97		130.0	
10625-AAA	IEEE 802.11ac WiFi (40MHz, MCS9, 90pc duty cycle)	X	6.04	68.29	17.42	0.46	130.0	± 9.6 %
		Y	5.98	68.09	17.27		130.0	
		Z	6.04	68.48	17.62		130.0	
10626-AAA	IEEE 802.11ac WiFi (80MHz, MCS0, 90pc duty cycle)	X	5.71	67.01	16.62	0.46	130.0	± 9.6 %
		Y	5.67	66.86	16.50		130.0	
		Z	5.72	67.21	16.83		130.0	
10627-AAA	IEEE 802.11ac WiFi (80MHz, MCS1, 90pc duty cycle)	X	5.98	67.64	16.90	0.46	130.0	± 9.6 %
		Y	5.95	67.51	16.78		130.0	
		Z	6.00	67.88	17.13		130.0	
10628-AAA	IEEE 802.11ac WiFi (80MHz, MCS2, 90pc duty cycle)	X	5.78	67.21	16.62	0.46	130.0	± 9.6 %
		Y	5.73	67.02	16.48		130.0	
		Z	5.78	67.39	16.83		130.0	
10629-AAA	IEEE 802.11ac WiFi (80MHz, MCS3, 90pc duty cycle)	X	5.86	67.26	16.64	0.46	130.0	± 9.6 %
		Y	5.82	67.11	16.52		130.0	
		Z	5.88	67.49	16.87		130.0	
10630-AAA	IEEE 802.11ac WiFi (80MHz, MCS4, 90pc duty cycle)	X	6.49	69.35	17.69	0.46	130.0	± 9.6 %
		Y	6.42	69.07	17.49		130.0	
		Z	6.48	69.48	17.86		130.0	
10631-AAA	IEEE 802.11ac WiFi (80MHz, MCS5, 90pc duty cycle)	X	6.27	68.75	17.56	0.46	130.0	± 9.6 %
		Y	6.19	68.51	17.40		130.0	
		Z	6.25	68.87	17.73		130.0	
10632-AAA	IEEE 802.11ac WiFi (80MHz, MCS6, 90pc duty cycle)	X	5.93	67.62	17.01	0.46	130.0	± 9.6 %
		Y	5.90	67.51	16.91		130.0	
		Z	5.95	67.87	17.25		130.0	
10633-AAA	IEEE 802.11ac WiFi (80MHz, MCS7, 90pc duty cycle)	X	5.84	67.36	16.72	0.46	130.0	± 9.6 %
		Y	5.78	67.14	16.56		130.0	
		Z	5.84	67.50	16.90		130.0	
10634-AAA	IEEE 802.11ac WiFi (80MHz, MCS8, 90pc duty cycle)	X	5.82	67.34	16.76	0.46	130.0	± 9.6 %
		Y	5.76	67.16	16.63		130.0	
		Z	5.82	67.51	16.96		130.0	
10635-AAA	IEEE 802.11ac WiFi (80MHz, MCS9, 90pc duty cycle)	X	5.72	66.79	16.26	0.46	130.0	± 9.6 %
		Y	5.66	66.55	16.08		130.0	
		Z	5.71	66.92	16.43		130.0	
10636-AAB	IEEE 802.11ac WiFi (160MHz, MCS0, 90pc duty cycle)	X	6.13	67.40	16.71	0.46	130.0	± 9.6 %
		Y	6.09	67.24	16.59		130.0	
		Z	6.15	67.58	16.91		130.0	
10637-AAB	IEEE 802.11ac WiFi (160MHz, MCS1, 90pc duty cycle)	X	6.30	67.81	16.90	0.46	130.0	± 9.6 %
		Y	6.26	67.67	16.79		130.0	
		Z	6.32	68.02	17.11		130.0	
10638-AAB	IEEE 802.11ac WiFi (160MHz, MCS2, 90pc duty cycle)	X	6.30	67.79	16.87	0.46	130.0	± 9.6 %
		Y	6.26	67.64	16.75		130.0	
		Z	6.32	67.99	17.07		130.0	

10639-AAB	IEEE 802.11ac WiFi (160MHz, MCS3, 90pc duty cycle)	X	6.28	67.75	16.89	0.46	130.0	± 9.6 %
		Y	6.24	67.58	16.76		130.0	
		Z	6.29	67.91	17.08		130.0	
10640-AAB	IEEE 802.11ac WiFi (160MHz, MCS4, 90pc duty cycle)	X	6.32	67.86	16.90	0.46	130.0	± 9.6 %
		Y	6.26	67.64	16.74		130.0	
		Z	6.31	67.99	17.06		130.0	
10641-AAB	IEEE 802.11ac WiFi (160MHz, MCS5, 90pc duty cycle)	X	6.31	67.61	16.79	0.46	130.0	± 9.6 %
		Y	6.28	67.46	16.67		130.0	
		Z	6.34	67.81	16.99		130.0	
10642-AAB	IEEE 802.11ac WiFi (160MHz, MCS6, 90pc duty cycle)	X	6.36	67.87	17.07	0.46	130.0	± 9.6 %
		Y	6.32	67.71	16.95		130.0	
		Z	6.37	68.04	17.26		130.0	
10643-AAB	IEEE 802.11ac WiFi (160MHz, MCS7, 90pc duty cycle)	X	6.21	67.62	16.86	0.46	130.0	± 9.6 %
		Y	6.16	67.44	16.72		130.0	
		Z	6.22	67.79	17.05		130.0	
10644-AAB	IEEE 802.11ac WiFi (160MHz, MCS8, 90pc duty cycle)	X	6.44	68.32	17.24	0.46	130.0	± 9.6 %
		Y	6.37	68.06	17.06		130.0	
		Z	6.42	68.41	17.38		130.0	
10645-AAB	IEEE 802.11ac WiFi (160MHz, MCS9, 90pc duty cycle)	X	6.93	69.31	17.68	0.46	130.0	± 9.6 %
		Y	6.90	69.18	17.57		130.0	
		Z	6.94	69.49	17.88		130.0	
10646-AAD	LTE-TDD (SC-FDMA, 1 RB, 5 MHz, QPSK, UL Subframe=2,7)	X	100.00	143.75	46.61	9.30	60.0	± 9.6 %
		Y	66.95	133.56	43.77		60.0	
		Z	100.00	145.58	47.35		60.0	
10647-AAC	LTE-TDD (SC-FDMA, 1 RB, 20 MHz, QPSK, UL Subframe=2,7)	X	100.00	144.82	47.06	9.30	60.0	± 9.6 %
		Y	70.78	135.89	44.56		60.0	
		Z	100.00	146.77	47.85		60.0	
10648-AAA	CDMA2000 (1x Advanced)	X	0.95	68.06	13.80	0.00	150.0	± 9.6 %
		Y	0.76	64.92	11.72		150.0	
		Z	1.56	75.79	17.40		150.0	
10652-AAB	LTE-TDD (OFDMA, 5 MHz, E-TM 3.1, Clipping 44%)	X	4.56	69.75	18.05	2.23	80.0	± 9.6 %
		Y	4.46	69.30	17.71		80.0	
		Z	4.70	70.77	18.63		80.0	
10653-AAB	LTE-TDD (OFDMA, 10 MHz, E-TM 3.1, Clipping 44%)	X	4.96	68.64	17.95	2.23	80.0	± 9.6 %
		Y	4.89	68.27	17.67		80.0	
		Z	5.01	69.17	18.32		80.0	
10654-AAB	LTE-TDD (OFDMA, 15 MHz, E-TM 3.1, Clipping 44%)	X	4.89	68.25	17.93	2.23	80.0	± 9.6 %
		Y	4.83	67.89	17.66		80.0	
		Z	4.92	68.70	18.27		80.0	
10655-AAB	LTE-TDD (OFDMA, 20 MHz, E-TM 3.1, Clipping 44%)	X	4.95	68.27	17.97	2.23	80.0	± 9.6 %
		Y	4.88	67.89	17.69		80.0	
		Z	4.98	68.67	18.30		80.0	

^E Uncertainty is determined using the max. deviation from linear response applying rectangular distribution and is expressed for the square of the field value.



Accredited by the Swiss Accreditation Service (SAS)
The Swiss Accreditation Service is one of the signatories to the EA
Multilateral Agreement for the recognition of calibration certificates

Accreditation No.: **SCS 0108**

Client **PC Test**

Certificate No: **EX3-7410_Jul17**

CALIBRATION CERTIFICATE

Object: **EX3DV4 - SN:7410**

Calibration procedure(s): **QA CAL-01.v9, QA CAL-23.v5, QA CAL-25.v6
Calibration procedure for dosimetric E-field probes**

Calibration date: **July 17, 2017**

*BN ✓
8/3/2017*

This calibration certificate documents the traceability to national standards, which realize the physical units of measurements (SI).
The measurements and the uncertainties with confidence probability are given on the following pages and are part of the certificate.

All calibrations have been conducted in the closed laboratory facility: environment temperature (22 ± 3)°C and humidity < 70%.

Calibration Equipment used (M&TE critical for calibration)

Primary Standards	ID	Cal Date (Certificate No.)	Scheduled Calibration
Power meter NRP	SN: 104778	04-Apr-17 (No. 217-02521/02522)	Apr-18
Power sensor NRP-Z91	SN: 103244	04-Apr-17 (No. 217-02521)	Apr-18
Power sensor NRP-Z91	SN: 103245	04-Apr-17 (No. 217-02525)	Apr-18
Reference 20 dB Attenuator	SN: S5277 (20x)	07-Apr-17 (No. 217-02528)	Apr-18
Reference Probe ES3DV2	SN: 3013	31-Dec-16 (No. ES3-3013_Dec16)	Dec-17
DAE4	SN: 660	7-Dec-16 (No. DAE4-660_Dec16)	Dec-17
Secondary Standards	ID	Check Date (in house)	Scheduled Check
Power meter E4419B	SN: GB41293874	06-Apr-16 (in house check Jun-16)	In house check: Jun-18
Power sensor E4412A	SN: MY41498087	06-Apr-16 (in house check Jun-16)	In house check: Jun-18
Power sensor E4412A	SN: 000110210	06-Apr-16 (in house check Jun-16)	In house check: Jun-18
RF generator HP 8648C	SN: US3642U01700	04-Aug-99 (in house check Jun-16)	In house check: Jun-18
Network Analyzer HP 8753E	SN: US37390585	18-Oct-01 (in house check Oct-16)	In house check: Oct-17

Calibrated by:	Name Jeton Kastrati	Function Laboratory Technician	Signature
Approved by:	Name Katja Pokovic	Technical Manager	

Issued: July 17, 2017

This calibration certificate shall not be reproduced except in full without written approval of the laboratory.



Accredited by the Swiss Accreditation Service (SAS)

The Swiss Accreditation Service is one of the signatories to the EA
Multilateral Agreement for the recognition of calibration certificates

Accreditation No.: **SCS 0108**

Glossary:

TSL	tissue simulating liquid
NORM _{x,y,z}	sensitivity in free space
ConvF	sensitivity in TSL / NORM _{x,y,z}
DCP	diode compression point
CF	crest factor (1/duty_cycle) of the RF signal
A, B, C, D	modulation dependent linearization parameters
Polarization φ	φ rotation around probe axis
Polarization ϑ	ϑ rotation around an axis that is in the plane normal to probe axis (at measurement center), i.e., $\vartheta = 0$ is normal to probe axis
Connector Angle	information used in DASY system to align probe sensor X to the robot coordinate system

Calibration is Performed According to the Following Standards:

- a) IEEE Std 1528-2013, "IEEE Recommended Practice for Determining the Peak Spatial-Averaged Specific Absorption Rate (SAR) in the Human Head from Wireless Communications Devices: Measurement Techniques", June 2013
- b) IEC 62209-1, "Measurement procedure for the assessment of Specific Absorption Rate (SAR) from hand-held and body-mounted devices used next to the ear (frequency range of 300 MHz to 6 GHz)", July 2016
- c) IEC 62209-2, "Procedure to determine the Specific Absorption Rate (SAR) for wireless communication devices used in close proximity to the human body (frequency range of 30 MHz to 6 GHz)", March 2010
- d) KDB 865664, "SAR Measurement Requirements for 100 MHz to 6 GHz"

Methods Applied and Interpretation of Parameters:

- **NORM_{x,y,z}**: Assessed for E-field polarization $\vartheta = 0$ ($f \leq 900$ MHz in TEM-cell; $f > 1800$ MHz: R22 waveguide). NORM_{x,y,z} are only intermediate values, i.e., the uncertainties of NORM_{x,y,z} does not affect the E²-field uncertainty inside TSL (see below ConvF).
- **NORM(f)_{x,y,z}** = NORM_{x,y,z} * frequency_response (see Frequency Response Chart). This linearization is implemented in DASY4 software versions later than 4.2. The uncertainty of the frequency response is included in the stated uncertainty of ConvF.
- **DCP_{x,y,z}**: DCP are numerical linearization parameters assessed based on the data of power sweep with CW signal (no uncertainty required). DCP does not depend on frequency nor media.
- **PAR**: PAR is the Peak to Average Ratio that is not calibrated but determined based on the signal characteristics
- **A_{x,y,z}; B_{x,y,z}; C_{x,y,z}; D_{x,y,z}; VR_{x,y,z}**: A, B, C, D are numerical linearization parameters assessed based on the data of power sweep for specific modulation signal. The parameters do not depend on frequency nor media. VR is the maximum calibration range expressed in RMS voltage across the diode.
- **ConvF and Boundary Effect Parameters**: Assessed in flat phantom using E-field (or Temperature Transfer Standard for $f \leq 800$ MHz) and inside waveguide using analytical field distributions based on power measurements for $f > 800$ MHz. The same setups are used for assessment of the parameters applied for boundary compensation (alpha, depth) of which typical uncertainty values are given. These parameters are used in DASY4 software to improve probe accuracy close to the boundary. The sensitivity in TSL corresponds to NORM_{x,y,z} * ConvF whereby the uncertainty corresponds to that given for ConvF. A frequency dependent ConvF is used in DASY version 4.4 and higher which allows extending the validity from ± 50 MHz to ± 100 MHz.
- **Spherical isotropy (3D deviation from isotropy)**: in a field of low gradients realized using a flat phantom exposed by a patch antenna.
- **Sensor Offset**: The sensor offset corresponds to the offset of virtual measurement center from the probe tip (on probe axis). No tolerance required.
- **Connector Angle**: The angle is assessed using the information gained by determining the NORM_x (no uncertainty required).

Probe EX3DV4

SN:7410

Manufactured: November 24, 2015
Calibrated: July 17, 2017

Calibrated for DASY/EASY Systems
(Note: non-compatible with DASY2 system!)

DASY/EASY - Parameters of Probe: EX3DV4 - SN:7410

Basic Calibration Parameters

	Sensor X	Sensor Y	Sensor Z	Unc (k=2)
Norm ($\mu\text{V}/(\text{V}/\text{m})^{2.5}$) ^A	0.40	0.46	0.43	$\pm 10.1 \%$
DCP (mV) ^B	95.4	94.7	91.2	

Modulation Calibration Parameters

UID	Communication System Name		A dB	B dB $\sqrt{\mu\text{V}}$	C	D dB	VR mV	Unc ^E (k=2)
0	CW	X	0.0	0.0	1.0	0.00	130.7	$\pm 3.5 \%$
		Y	0.0	0.0	1.0		146.7	
		Z	0.0	0.0	1.0		132.5	

Note: For details on UID parameters see Appendix.

Sensor Model Parameters

	C1 fF	C2 fF	α V^{-1}	T1 $\text{ms}\cdot\text{V}^{-2}$	T2 $\text{ms}\cdot\text{V}^{-1}$	T3 ms	T4 V^{-2}	T5 V^{-1}	T6
X	41.43	313.6	36.54	8.525	0.381	5.024	0.000	0.467	1.003
Y	41.67	315.5	36.57	10.32	0.000	5.055	0.334	0.426	1.004
Z	51.58	393.9	37.05	11.42	0.427	5.066	0.000	0.561	1.006

The reported uncertainty of measurement is stated as the standard uncertainty of measurement multiplied by the coverage factor $k=2$, which for a normal distribution corresponds to a coverage probability of approximately 95%.

^A The uncertainties of Norm X,Y,Z do not affect the E^2 -field uncertainty inside TSL (see Pages 5 and 6).

^B Numerical linearization parameter: uncertainty not required.

^E Uncertainty is determined using the max. deviation from linear response applying rectangular distribution and is expressed for the square of the field value.

DASY/EASY - Parameters of Probe: EX3DV4 - SN:7410

Calibration Parameter Determined in Head Tissue Simulating Media

f (MHz) ^C	Relative Permittivity ^F	Conductivity (S/m) ^F	ConvF X	ConvF Y	ConvF Z	Alpha ^G	Depth (mm) ^G	Unc (k=2)
750	41.9	0.89	10.60	10.60	10.60	0.53	0.80	± 12.0 %
835	41.5	0.90	10.08	10.08	10.08	0.41	0.98	± 12.0 %
1750	40.1	1.37	8.66	8.66	8.66	0.41	0.82	± 12.0 %
1900	40.0	1.40	8.37	8.37	8.37	0.28	1.19	± 12.0 %
2300	39.5	1.67	8.02	8.02	8.02	0.35	0.80	± 12.0 %
2450	39.2	1.80	7.68	7.68	7.68	0.33	0.89	± 12.0 %
2600	39.0	1.96	7.42	7.42	7.42	0.40	0.80	± 12.0 %

^C Frequency validity above 300 MHz of ± 100 MHz only applies for DASY v4.4 and higher (see Page 2), else it is restricted to ± 50 MHz. The uncertainty is the RSS of the ConvF uncertainty at calibration frequency and the uncertainty for the indicated frequency band. Frequency validity below 300 MHz is ± 10, 25, 40, 50 and 70 MHz for ConvF assessments at 30, 64, 128, 150 and 220 MHz respectively. Above 5 GHz frequency validity can be extended to ± 110 MHz.

^F At frequencies below 3 GHz, the validity of tissue parameters (ϵ and σ) can be relaxed to ± 10% if liquid compensation formula is applied to measured SAR values. At frequencies above 3 GHz, the validity of tissue parameters (ϵ and σ) is restricted to ± 5%. The uncertainty is the RSS of the ConvF uncertainty for indicated target tissue parameters.

^G Alpha/Depth are determined during calibration. SPEAG warrants that the remaining deviation due to the boundary effect after compensation is always less than ± 1% for frequencies below 3 GHz and below ± 2% for frequencies between 3-6 GHz at any distance larger than half the probe tip diameter from the boundary.

DASY/EASY - Parameters of Probe: EX3DV4 - SN:7410

Calibration Parameter Determined in Body Tissue Simulating Media

f (MHz) ^C	Relative Permittivity ^F	Conductivity (S/m) ^F	ConvF X	ConvF Y	ConvF Z	Alpha ^G	Depth ^G (mm)	Unc (k=2)
750	55.5	0.96	10.19	10.19	10.19	0.33	1.02	± 12.0 %
835	55.2	0.97	9.95	9.95	9.95	0.50	0.80	± 12.0 %
1750	53.4	1.49	8.32	8.32	8.32	0.39	0.86	± 12.0 %
1900	53.3	1.52	7.98	7.98	7.98	0.44	0.86	± 12.0 %
2300	52.9	1.81	7.85	7.85	7.85	0.44	0.84	± 12.0 %
2450	52.7	1.95	7.69	7.69	7.69	0.37	0.89	± 12.0 %
2600	52.5	2.16	7.43	7.43	7.43	0.28	0.99	± 12.0 %

^C Frequency validity above 300 MHz of ± 100 MHz only applies for DASY v4.4 and higher (see Page 2), else it is restricted to ± 50 MHz. The uncertainty is the RSS of the ConvF uncertainty at calibration frequency and the uncertainty for the indicated frequency band. Frequency validity below 300 MHz is ± 10, 25, 40, 50 and 70 MHz for ConvF assessments at 30, 64, 128, 150 and 220 MHz respectively. Above 5 GHz frequency validity can be extended to ± 110 MHz.

^F At frequencies below 3 GHz, the validity of tissue parameters (ϵ and σ) can be relaxed to ± 10% if liquid compensation formula is applied to measured SAR values. At frequencies above 3 GHz, the validity of tissue parameters (ϵ and σ) is restricted to ± 5%. The uncertainty is the RSS of the ConvF uncertainty for indicated target tissue parameters.

^G Alpha/Depth are determined during calibration. SPEAG warrants that the remaining deviation due to the boundary effect after compensation is always less than ± 1% for frequencies below 3 GHz and below ± 2% for frequencies between 3-6 GHz at any distance larger than half the probe tip diameter from the boundary.

Frequency Response of E-Field (TEM-Cell:ifi110 EXX, Waveguide: R22)

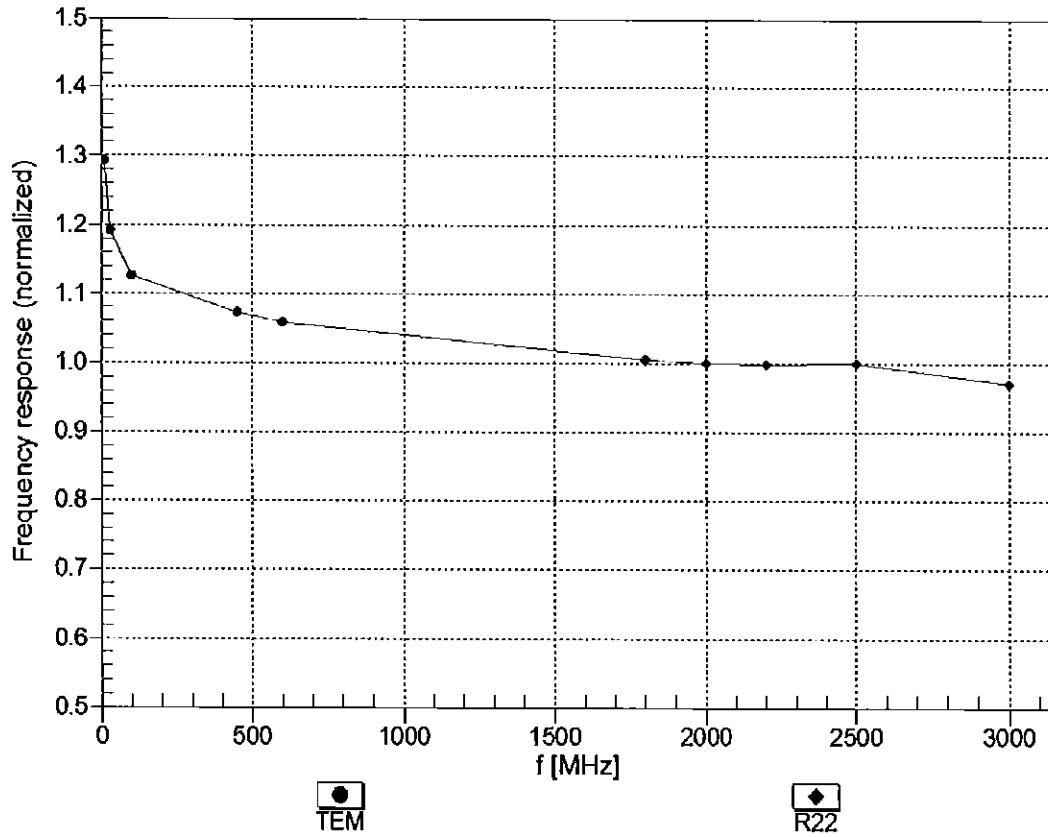

Uncertainty of Frequency Response of E-field: $\pm 6.3\%$ (k=2)

Receiving Pattern (ϕ), $\theta = 0^\circ$

f=600 MHz,TEM

f=1800 MHz,R22

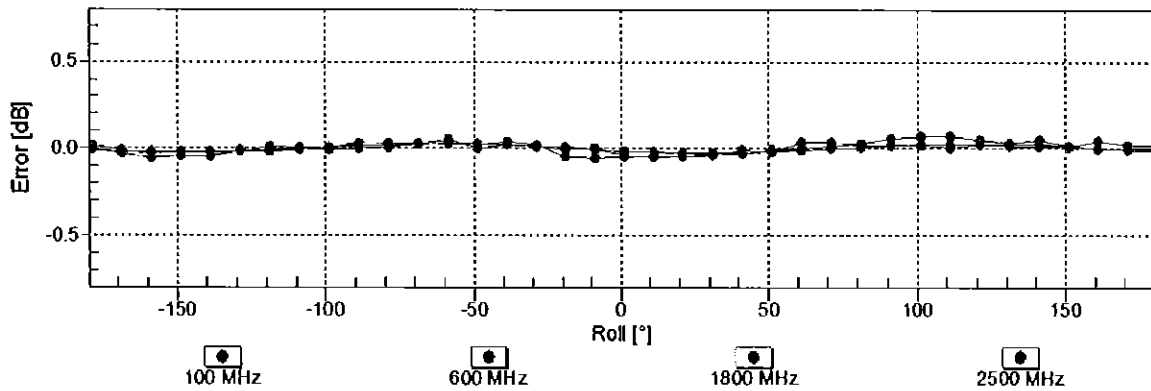
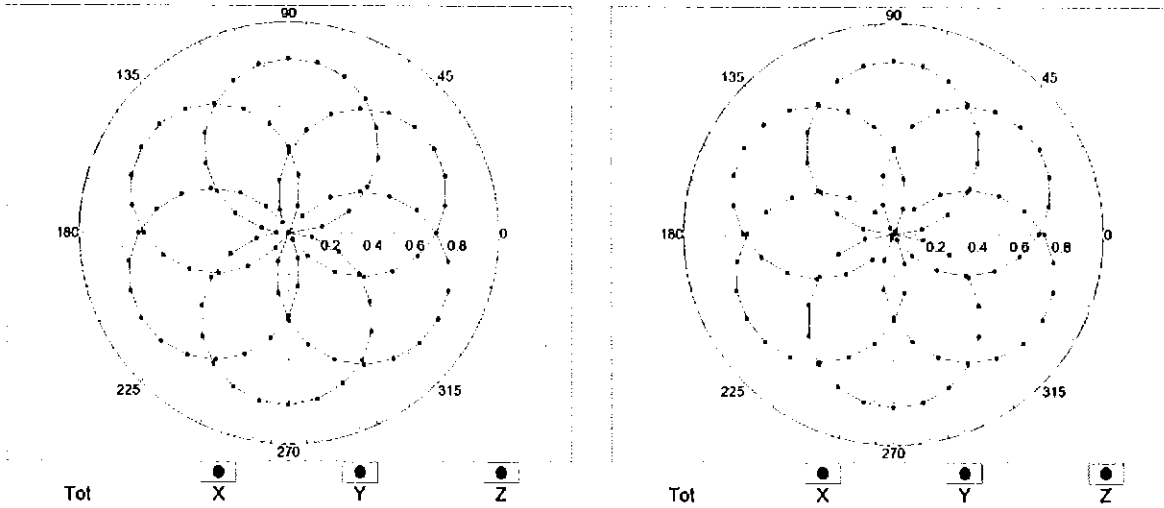

Uncertainty of Axial Isotropy Assessment: $\pm 0.5\%$ ($k=2$)

Dynamic Range $f(\text{SAR}_{\text{head}})$ (TEM cell, $f_{\text{eval}} = 1900 \text{ MHz}$)

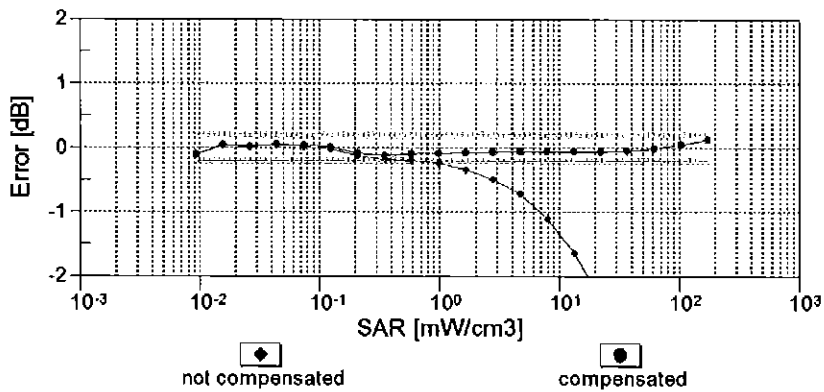
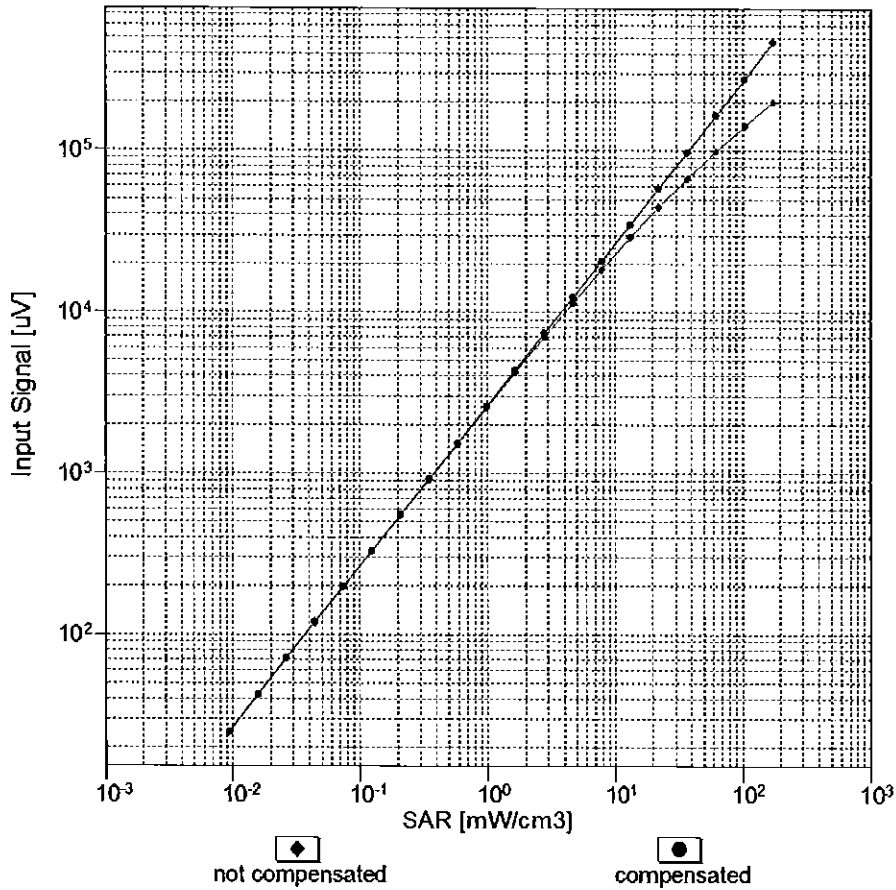

Uncertainty of Linearity Assessment: $\pm 0.6\%$ ($k=2$)

Conversion Factor Assessment

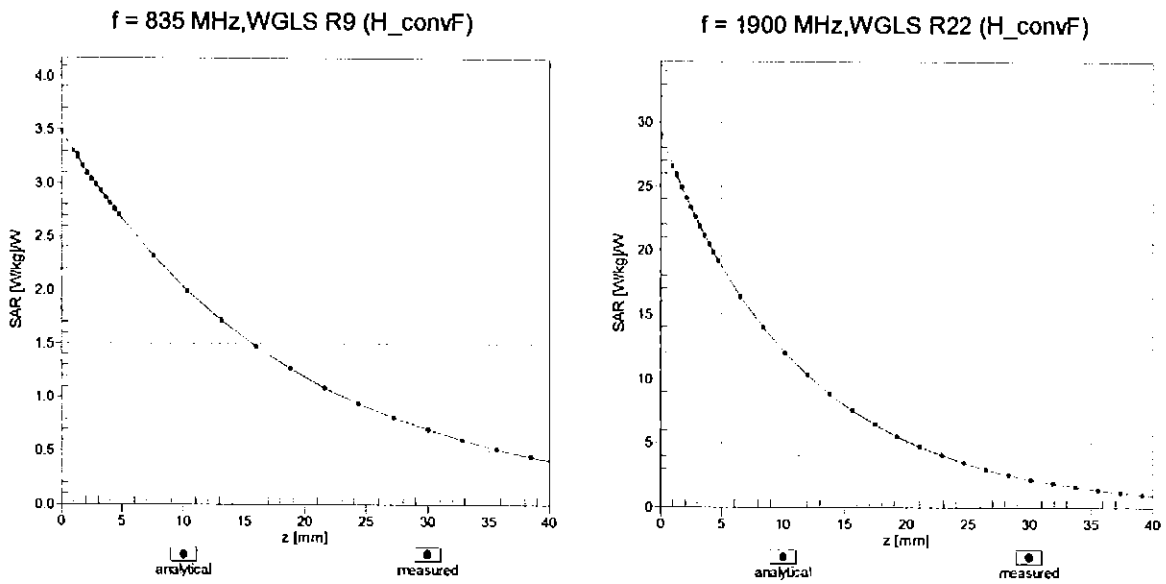

Deviation from Isotropy in Liquid Error (ϕ, ϑ), f = 900 MHz

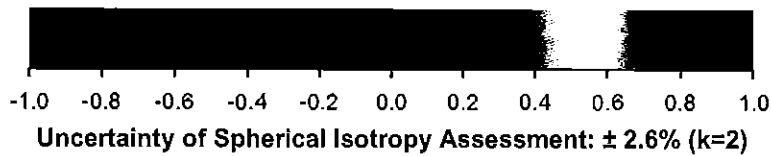
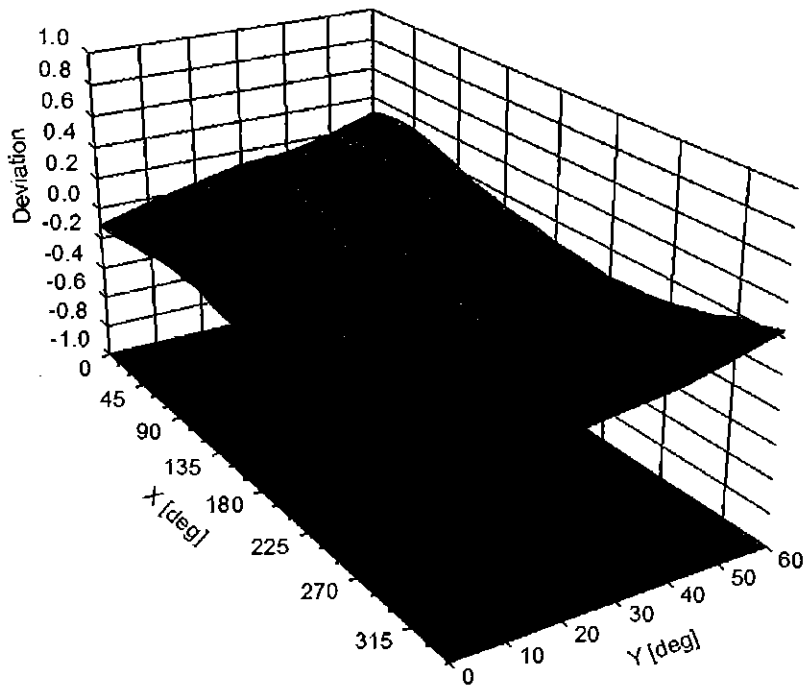

DASY/EASY - Parameters of Probe: EX3DV4 - SN:7410**Other Probe Parameters**

Sensor Arrangement	Triangular
Connector Angle (°)	1.2
Mechanical Surface Detection Mode	enabled
Optical Surface Detection Mode	disabled
Probe Overall Length	337 mm
Probe Body Diameter	10 mm
Tip Length	9 mm
Tip Diameter	2.5 mm
Probe Tip to Sensor X Calibration Point	1 mm
Probe Tip to Sensor Y Calibration Point	1 mm
Probe Tip to Sensor Z Calibration Point	1 mm
Recommended Measurement Distance from Surface	1.4 mm

Appendix: Modulation Calibration Parameters

UID	Communication System Name		A dB	B dB $\sqrt{\mu}$ V	C	D dB	VR mV	Max Unc ^E (k=2)
0	CW	X	0.00	0.00	1.00	0.00	130.7	$\pm 3.5\%$
		Y	0.00	0.00	1.00		146.7	
		Z	0.00	0.00	1.00		132.5	
10010- CAA	SAR Validation (Square, 100ms, 10ms)	X	2.07	65.38	9.86	10.00	20.0	$\pm 9.6\%$
		Y	1.71	64.71	9.07		20.0	
		Z	3.44	71.14	12.92		20.0	
10011- CAB	UMTS-FDD (WCDMA)	X	1.05	67.82	15.62	0.00	150.0	$\pm 9.6\%$
		Y	1.11	68.91	16.28		150.0	
		Z	1.02	66.59	14.94		150.0	
10012- CAB	IEEE 802.11b WiFi 2.4 GHz (DSSS, 1 Mbps)	X	1.16	63.70	15.28	0.41	150.0	$\pm 9.6\%$
		Y	1.18	64.10	15.65		150.0	
		Z	1.17	63.41	15.09		150.0	
10013- CAB	IEEE 802.11g WiFi 2.4 GHz (DSSS-OFDM, 6 Mbps)	X	4.78	66.61	17.05	1.46	150.0	$\pm 9.6\%$
		Y	4.80	66.74	17.21		150.0	
		Z	4.93	66.52	17.11		150.0	
10021- DAC	GSM-FDD (TDMA, GMSK)	X	100.00	111.37	25.72	9.39	50.0	$\pm 9.6\%$
		Y	100.00	111.58	25.35		50.0	
		Z	100.00	117.02	28.59		50.0	
10023- DAC	GPRS-FDD (TDMA, GMSK, TN 0)	X	100.00	110.83	25.53	9.57	50.0	$\pm 9.6\%$
		Y	1707.76	142.54	31.32		50.0	
		Z	100.00	116.46	28.39		50.0	
10024- DAC	GPRS-FDD (TDMA, GMSK, TN 0-1)	X	100.00	111.84	24.81	6.56	60.0	$\pm 9.6\%$
		Y	100.00	114.48	25.68		60.0	
		Z	100.00	118.35	28.09		60.0	
10025- DAC	EDGE-FDD (TDMA, 8PSK, TN 0)	X	3.46	65.17	23.20	12.57	50.0	$\pm 9.6\%$
		Y	5.27	82.06	33.95		50.0	
		Z	3.61	65.78	23.81		50.0	
10026- DAC	EDGE-FDD (TDMA, 8PSK, TN 0-1)	X	6.19	83.69	29.67	9.56	60.0	$\pm 9.6\%$
		Y	7.27	90.43	33.46		60.0	
		Z	7.46	87.49	31.34		60.0	
10027- DAC	GPRS-FDD (TDMA, GMSK, TN 0-1-2)	X	100.00	114.23	25.06	4.80	80.0	$\pm 9.6\%$
		Y	100.00	119.65	27.19		80.0	
		Z	100.00	121.09	28.48		80.0	
10028- DAC	GPRS-FDD (TDMA, GMSK, TN 0-1-2-3)	X	100.00	118.39	26.12	3.55	100.0	$\pm 9.6\%$
		Y	100.00	127.35	29.74		100.0	
		Z	100.00	125.00	29.42		100.0	
10029- DAC	EDGE-FDD (TDMA, 8PSK, TN 0-1-2)	X	4.31	75.70	25.15	7.80	80.0	$\pm 9.6\%$
		Y	4.62	78.76	27.21		80.0	
		Z	5.10	78.80	26.60		80.0	
10030- CAA	IEEE 802.15.1 Bluetooth (GFSK, DH1)	X	100.00	110.42	23.70	5.30	70.0	$\pm 9.6\%$
		Y	100.00	113.76	24.95		70.0	
		Z	100.00	117.44	27.22		70.0	
10031- CAA	IEEE 802.15.1 Bluetooth (GFSK, DH3)	X	100.00	118.50	24.77	1.88	100.0	$\pm 9.6\%$
		Y	100.00	132.66	30.37		100.0	
		Z	100.00	126.29	28.44		100.0	

10032-CAA	IEEE 802.15.1 Bluetooth (GFSK, DH5)	X	100.00	133.47	29.67	1.17	100.0	± 9.6 %
		Y	100.00	157.48	38.89		100.0	
		Z	100.00	136.04	31.29		100.0	
10033-CAA	IEEE 802.15.1 Bluetooth (PI/4-DQPSK, DH1)	X	8.66	91.15	24.16	5.30	70.0	± 9.6 %
		Y	61.92	124.81	33.89		70.0	
		Z	18.44	105.53	29.79		70.0	
10034-CAA	IEEE 802.15.1 Bluetooth (PI/4-DQPSK, DH3)	X	2.66	76.47	17.66	1.88	100.0	± 9.6 %
		Y	4.91	85.76	21.28		100.0	
		Z	3.14	79.12	19.77		100.0	
10035-CAA	IEEE 802.15.1 Bluetooth (PI/4-DQPSK, DH5)	X	1.87	72.76	15.96	1.17	100.0	± 9.6 %
		Y	2.71	78.22	18.36		100.0	
		Z	2.01	73.50	17.25		100.0	
10036-CAA	IEEE 802.15.1 Bluetooth (8-DPSK, DH1)	X	12.89	97.56	26.18	5.30	70.0	± 9.6 %
		Y	100.00	133.04	35.90		70.0	
		Z	33.52	115.95	32.67		70.0	
10037-CAA	IEEE 802.15.1 Bluetooth (8-DPSK, DH3)	X	2.40	75.20	17.16	1.88	100.0	± 9.6 %
		Y	4.17	83.65	20.57		100.0	
		Z	2.91	78.15	19.38		100.0	
10038-CAA	IEEE 802.15.1 Bluetooth (8-DPSK, DH5)	X	1.89	73.11	16.24	1.17	100.0	± 9.6 %
		Y	2.73	78.67	18.67		100.0	
		Z	2.03	73.85	17.51		100.0	
10039-CAB	CDMA2000 (1xRTT, RC1)	X	1.93	73.30	15.79	0.00	150.0	± 9.6 %
		Y	2.16	74.82	16.50		150.0	
		Z	1.82	71.39	15.74		150.0	
10042-CAB	IS-54 / IS-136 FDD (TDMA/FDM, PI/4-DQPSK, Halfrate)	X	100.00	108.18	23.51	7.78	50.0	± 9.6 %
		Y	100.00	108.75	23.44		50.0	
		Z	100.00	113.77	26.32		50.0	
10044-CAA	IS-91/EIA/TIA-553 FDD (FDMA, FM)	X	0.00	97.63	1.20	0.00	150.0	± 9.6 %
		Y	0.00	97.90	0.75		150.0	
		Z	0.00	95.09	2.63		150.0	
10048-CAA	DECT (TDD, TDMA/FDM, GFSK, Full Slot, 24)	X	29.38	92.85	22.01	13.80	25.0	± 9.6 %
		Y	100.00	106.19	24.33		25.0	
		Z	100.00	113.54	28.60		25.0	
10049-CAA	DECT (TDD, TDMA/FDM, GFSK, Double Slot, 12)	X	92.32	108.50	25.07	10.79	40.0	± 9.6 %
		Y	100.00	108.13	24.14		40.0	
		Z	100.00	114.66	27.93		40.0	
10056-CAA	UMTS-TDD (TD-SCDMA, 1.28 Mcps)	X	28.80	103.53	27.62	9.03	50.0	± 9.6 %
		Y	100.00	125.87	33.73		50.0	
		Z	90.56	125.80	34.77		50.0	
10058-DAC	EDGE-FDD (TDMA, 8PSK, TN 0-1-2-3)	X	3.55	72.15	22.79	6.55	100.0	± 9.6 %
		Y	3.72	74.09	24.21		100.0	
		Z	4.11	74.59	23.97		100.0	
10059-CAB	IEEE 802.11b WiFi 2.4 GHz (DSSS, 2 Mbps)	X	1.17	64.52	15.76	0.61	110.0	± 9.6 %
		Y	1.20	65.09	16.25		110.0	
		Z	1.19	64.38	15.68		110.0	
10060-CAB	IEEE 802.11b WiFi 2.4 GHz (DSSS, 5.5 Mbps)	X	5.38	97.28	26.54	1.30	110.0	± 9.6 %
		Y	94.12	145.74	39.06		110.0	
		Z	7.25	100.99	27.69		110.0	

10061-CAB	IEEE 802.11b WiFi 2.4 GHz (DSSS, 11 Mbps)	X	2.03	75.84	20.79	2.04	110.0	± 9.6 %
		Y	2.53	80.86	23.32		110.0	
		Z	2.46	78.49	22.05		110.0	
10062-CAB	IEEE 802.11a/h WiFi 5 GHz (OFDM, 6 Mbps)	X	4.60	66.68	16.54	0.49	100.0	± 9.6 %
		Y	4.62	66.77	16.65		100.0	
		Z	4.74	66.54	16.54		100.0	
10063-CAB	IEEE 802.11a/h WiFi 5 GHz (OFDM, 9 Mbps)	X	4.61	66.74	16.62	0.72	100.0	± 9.6 %
		Y	4.63	66.85	16.75		100.0	
		Z	4.75	66.63	16.64		100.0	
10064-CAB	IEEE 802.11a/h WiFi 5 GHz (OFDM, 12 Mbps)	X	4.88	66.97	16.83	0.86	100.0	± 9.6 %
		Y	4.90	67.08	16.96		100.0	
		Z	5.06	66.93	16.89		100.0	
10065-CAB	IEEE 802.11a/h WiFi 5 GHz (OFDM, 18 Mbps)	X	4.74	66.82	16.90	1.21	100.0	± 9.6 %
		Y	4.76	66.95	17.05		100.0	
		Z	4.91	66.81	16.98		100.0	
10066-CAB	IEEE 802.11a/h WiFi 5 GHz (OFDM, 24 Mbps)	X	4.74	66.80	17.04	1.46	100.0	± 9.6 %
		Y	4.77	66.94	17.21		100.0	
		Z	4.93	66.83	17.15		100.0	
10067-CAB	IEEE 802.11a/h WiFi 5 GHz (OFDM, 36 Mbps)	X	5.03	66.98	17.46	2.04	100.0	± 9.6 %
		Y	5.05	67.14	17.66		100.0	
		Z	5.21	66.94	17.57		100.0	
10068-CAB	IEEE 802.11a/h WiFi 5 GHz (OFDM, 48 Mbps)	X	5.05	66.91	17.63	2.55	100.0	± 9.6 %
		Y	5.07	67.08	17.84		100.0	
		Z	5.27	67.04	17.82		100.0	
10069-CAB	IEEE 802.11a/h WiFi 5 GHz (OFDM, 54 Mbps)	X	5.12	66.93	17.81	2.67	100.0	± 9.6 %
		Y	5.15	67.10	18.04		100.0	
		Z	5.34	66.99	17.99		100.0	
10071-CAB	IEEE 802.11g WiFi 2.4 GHz (DSSS/OFDM, 9 Mbps)	X	4.86	66.65	17.32	1.99	100.0	± 9.6 %
		Y	4.89	66.79	17.50		100.0	
		Z	5.01	66.60	17.41		100.0	
10072-CAB	IEEE 802.11g WiFi 2.4 GHz (DSSS/OFDM, 12 Mbps)	X	4.82	66.89	17.50	2.30	100.0	± 9.6 %
		Y	4.84	67.05	17.70		100.0	
		Z	4.99	66.92	17.63		100.0	
10073-CAB	IEEE 802.11g WiFi 2.4 GHz (DSSS/OFDM, 18 Mbps)	X	4.86	67.00	17.79	2.83	100.0	± 9.6 %
		Y	4.89	67.17	18.02		100.0	
		Z	5.04	67.03	17.94		100.0	
10074-CAB	IEEE 802.11g WiFi 2.4 GHz (DSSS/OFDM, 24 Mbps)	X	4.85	66.87	17.91	3.30	100.0	± 9.6 %
		Y	4.86	67.04	18.15		100.0	
		Z	5.01	66.88	18.08		100.0	
10075-CAB	IEEE 802.11g WiFi 2.4 GHz (DSSS/OFDM, 36 Mbps)	X	4.86	66.89	18.16	3.82	90.0	± 9.6 %
		Y	4.87	67.06	18.42		90.0	
		Z	5.04	67.00	18.40		90.0	
10076-CAB	IEEE 802.11g WiFi 2.4 GHz (DSSS/OFDM, 48 Mbps)	X	4.88	66.70	18.29	4.15	90.0	± 9.6 %
		Y	4.89	66.85	18.55		90.0	
		Z	5.03	66.71	18.47		90.0	
10077-CAB	IEEE 802.11g WiFi 2.4 GHz (DSSS/OFDM, 54 Mbps)	X	4.91	66.76	18.38	4.30	90.0	± 9.6 %
		Y	4.91	66.91	18.65		90.0	
		Z	5.05	66.76	18.56		90.0	

10081-CAB	CDMA2000 (1xRTT, RC3)	X	0.83	66.43	12.40	0.00	150.0	± 9.6 %
		Y	0.90	67.46	13.02		150.0	
		Z	0.87	65.72	12.74		150.0	
10082-CAB	IS-54 / IS-136 FDD (TDMA/FDM, PI/4-DQPSK, Fullrate)	X	0.60	60.00	4.03	4.77	80.0	± 9.6 %
		Y	1.74	63.67	4.99		80.0	
		Z	0.50	57.10	2.51		80.0	
10090-DAC	GPRS-FDD (TDMA, GMSK, TN 0-4)	X	100.00	111.84	24.82	6.56	60.0	± 9.6 %
		Y	100.00	114.47	25.69		60.0	
		Z	100.00	118.36	28.12		60.0	
10097-CAB	UMTS-FDD (HSDPA)	X	1.87	68.36	15.98	0.00	150.0	± 9.6 %
		Y	1.92	68.79	16.27		150.0	
		Z	1.83	67.16	15.53		150.0	
10098-CAB	UMTS-FDD (HSUPA, Subtest 2)	X	1.83	68.30	15.96	0.00	150.0	± 9.6 %
		Y	1.88	68.76	16.25		150.0	
		Z	1.79	67.10	15.49		150.0	
10099-DAC	EDGE-FDD (TDMA, 8PSK, TN 0-4)	X	6.23	83.81	29.72	9.56	60.0	± 9.6 %
		Y	7.34	90.66	33.54		60.0	
		Z	7.51	87.64	31.39		60.0	
10100-CAC	LTE-FDD (SC-FDMA, 100% RB, 20 MHz, QPSK)	X	3.10	70.42	16.91	0.00	150.0	± 9.6 %
		Y	3.17	70.79	17.14		150.0	
		Z	3.14	69.95	16.56		150.0	
10101-CAC	LTE-FDD (SC-FDMA, 100% RB, 20 MHz, 16-QAM)	X	3.21	67.53	16.05	0.00	150.0	± 9.6 %
		Y	3.24	67.71	16.18		150.0	
		Z	3.28	67.33	15.89		150.0	
10102-CAC	LTE-FDD (SC-FDMA, 100% RB, 20 MHz, 64-QAM)	X	3.31	67.53	16.15	0.00	150.0	± 9.6 %
		Y	3.34	67.67	16.26		150.0	
		Z	3.39	67.31	16.00		150.0	
10103-CAC	LTE-TDD (SC-FDMA, 100% RB, 20 MHz, QPSK)	X	5.23	73.47	19.72	3.98	65.0	± 9.6 %
		Y	5.84	75.95	21.01		65.0	
		Z	5.88	74.83	20.39		65.0	
10104-CAC	LTE-TDD (SC-FDMA, 100% RB, 20 MHz, 16-QAM)	X	5.46	71.98	19.77	3.98	65.0	± 9.6 %
		Y	5.63	73.01	20.49		65.0	
		Z	6.00	73.07	20.39		65.0	
10105-CAC	LTE-TDD (SC-FDMA, 100% RB, 20 MHz, 64-QAM)	X	5.42	71.61	19.91	3.98	65.0	± 9.6 %
		Y	5.43	72.06	20.36		65.0	
		Z	5.47	71.05	19.77		65.0	
10108-CAD	LTE-FDD (SC-FDMA, 100% RB, 10 MHz, QPSK)	X	2.70	69.72	16.76	0.00	150.0	± 9.6 %
		Y	2.76	70.10	16.99		150.0	
		Z	2.75	69.19	16.39		150.0	
10109-CAD	LTE-FDD (SC-FDMA, 100% RB, 10 MHz, 16-QAM)	X	2.86	67.48	15.96	0.00	150.0	± 9.6 %
		Y	2.89	67.67	16.11		150.0	
		Z	2.94	67.16	15.80		150.0	
10110-CAD	LTE-FDD (SC-FDMA, 100% RB, 5 MHz, QPSK)	X	2.18	68.93	16.34	0.00	150.0	± 9.6 %
		Y	2.24	69.40	16.63		150.0	
		Z	2.24	68.24	15.99		150.0	
10111-CAD	LTE-FDD (SC-FDMA, 100% RB, 5 MHz, 16-QAM)	X	2.61	68.71	16.36	0.00	150.0	± 9.6 %
		Y	2.63	68.84	16.47		150.0	
		Z	2.65	67.91	16.10		150.0	

10112-CAD	LTE-FDD (SC-FDMA, 100% RB, 10 MHz, 64-QAM)	X	2.99	67.52	16.03	0.00	150.0	± 9.6 %
		Y	3.01	67.67	16.15		150.0	
		Z	3.06	67.16	15.86		150.0	
10113-CAD	LTE-FDD (SC-FDMA, 100% RB, 5 MHz, 64-QAM)	X	2.77	68.89	16.50	0.00	150.0	± 9.6 %
		Y	2.78	68.97	16.58		150.0	
		Z	2.81	68.06	16.24		150.0	
10114-CAB	IEEE 802.11n (HT Greenfield, 13.5 Mbps, BPSK)	X	5.09	67.23	16.55	0.00	150.0	± 9.6 %
		Y	5.10	67.28	16.60		150.0	
		Z	5.19	67.11	16.46		150.0	
10115-CAB	IEEE 802.11n (HT Greenfield, 81 Mbps, 16-QAM)	X	5.34	67.29	16.58	0.00	150.0	± 9.6 %
		Y	5.35	67.33	16.63		150.0	
		Z	5.51	67.33	16.58		150.0	
10116-CAB	IEEE 802.11n (HT Greenfield, 135 Mbps, 64-QAM)	X	5.18	67.42	16.57	0.00	150.0	± 9.6 %
		Y	5.19	67.47	16.62		150.0	
		Z	5.30	67.34	16.50		150.0	
10117-CAB	IEEE 802.11n (HT Mixed, 13.5 Mbps, BPSK)	X	5.06	67.11	16.50	0.00	150.0	± 9.6 %
		Y	5.07	67.16	16.56		150.0	
		Z	5.16	66.99	16.42		150.0	
10118-CAB	IEEE 802.11n (HT Mixed, 81 Mbps, 16-QAM)	X	5.42	67.49	16.69	0.00	150.0	± 9.6 %
		Y	5.44	67.54	16.74		150.0	
		Z	5.60	67.55	16.70		150.0	
10119-CAB	IEEE 802.11n (HT Mixed, 135 Mbps, 64-QAM)	X	5.16	67.38	16.56	0.00	150.0	± 9.6 %
		Y	5.17	67.43	16.62		150.0	
		Z	5.27	67.27	16.48		150.0	
10140-CAC	LTE-FDD (SC-FDMA, 100% RB, 15 MHz, 16-QAM)	X	3.34	67.53	16.06	0.00	150.0	± 9.6 %
		Y	3.37	67.68	16.18		150.0	
		Z	3.42	67.31	15.91		150.0	
10141-CAC	LTE-FDD (SC-FDMA, 100% RB, 15 MHz, 64-QAM)	X	3.47	67.67	16.25	0.00	150.0	± 9.6 %
		Y	3.49	67.79	16.35		150.0	
		Z	3.55	67.42	16.09		150.0	
10142-CAD	LTE-FDD (SC-FDMA, 100% RB, 3 MHz, QPSK)	X	1.97	69.09	15.95	0.00	150.0	± 9.6 %
		Y	2.03	69.63	16.28		150.0	
		Z	2.02	68.20	15.69		150.0	
10143-CAD	LTE-FDD (SC-FDMA, 100% RB, 3 MHz, 16-QAM)	X	2.49	69.65	15.98	0.00	150.0	± 9.6 %
		Y	2.52	69.83	16.12		150.0	
		Z	2.51	68.62	15.86		150.0	
10144-CAD	LTE-FDD (SC-FDMA, 100% RB, 3 MHz, 64-QAM)	X	2.16	66.67	13.99	0.00	150.0	± 9.6 %
		Y	2.21	66.99	14.22		150.0	
		Z	2.30	66.43	14.30		150.0	
10145-CAD	LTE-FDD (SC-FDMA, 100% RB, 1.4 MHz, QPSK)	X	1.07	64.11	10.67	0.00	150.0	± 9.6 %
		Y	1.11	64.57	11.01		150.0	
		Z	1.31	65.51	12.40		150.0	
10146-CAD	LTE-FDD (SC-FDMA, 100% RB, 1.4 MHz, 16-QAM)	X	1.34	62.65	9.02	0.00	150.0	± 9.6 %
		Y	1.43	63.27	9.42		150.0	
		Z	2.01	66.35	12.18		150.0	
10147-CAD	LTE-FDD (SC-FDMA, 100% RB, 1.4 MHz, 64-QAM)	X	1.45	63.47	9.57	0.00	150.0	± 9.6 %
		Y	1.57	64.27	10.06		150.0	
		Z	2.34	68.34	13.28		150.0	

10149-CAC	LTE-FDD (SC-FDMA, 50% RB, 20 MHz, 16-QAM)	X	2.87	67.55	16.01	0.00	150.0	± 9.6 %
		Y	2.90	67.73	16.15		150.0	
		Z	2.95	67.22	15.84		150.0	
10150-CAC	LTE-FDD (SC-FDMA, 50% RB, 20 MHz, 64-QAM)	X	3.00	67.58	16.08	0.00	150.0	± 9.6 %
		Y	3.02	67.73	16.20		150.0	
		Z	3.07	67.21	15.90		150.0	
10151-CAC	LTE-TDD (SC-FDMA, 50% RB, 20 MHz, QPSK)	X	5.65	76.57	21.08	3.98	65.0	± 9.6 %
		Y	6.17	78.83	22.29		65.0	
		Z	6.35	77.82	21.74		65.0	
10152-CAC	LTE-TDD (SC-FDMA, 50% RB, 20 MHz, 16-QAM)	X	4.98	71.84	19.37	3.98	65.0	± 9.6 %
		Y	5.18	73.09	20.20		65.0	
		Z	5.53	73.00	20.11		65.0	
10153-CAC	LTE-TDD (SC-FDMA, 50% RB, 20 MHz, 64-QAM)	X	5.35	72.93	20.23	3.98	65.0	± 9.6 %
		Y	5.53	74.06	20.99		65.0	
		Z	5.88	73.94	20.90		65.0	
10154-CAD	LTE-FDD (SC-FDMA, 50% RB, 10 MHz, QPSK)	X	2.24	69.40	16.63	0.00	150.0	± 9.6 %
		Y	2.29	69.81	16.88		150.0	
		Z	2.29	68.69	16.27		150.0	
10155-CAD	LTE-FDD (SC-FDMA, 50% RB, 10 MHz, 16-QAM)	X	2.62	68.74	16.38	0.00	150.0	± 9.6 %
		Y	2.64	68.87	16.49		150.0	
		Z	2.65	67.91	16.11		150.0	
10156-CAD	LTE-FDD (SC-FDMA, 50% RB, 5 MHz, QPSK)	X	1.81	69.21	15.68	0.00	150.0	± 9.6 %
		Y	1.88	69.80	16.04		150.0	
		Z	1.87	68.31	15.53		150.0	
10157-CAD	LTE-FDD (SC-FDMA, 50% RB, 5 MHz, 16-QAM)	X	2.01	67.27	13.98	0.00	150.0	± 9.6 %
		Y	2.06	67.66	14.24		150.0	
		Z	2.13	67.00	14.37		150.0	
10158-CAD	LTE-FDD (SC-FDMA, 50% RB, 10 MHz, 64-QAM)	X	2.78	68.97	16.55	0.00	150.0	± 9.6 %
		Y	2.79	69.05	16.63		150.0	
		Z	2.81	68.12	16.28		150.0	
10159-CAD	LTE-FDD (SC-FDMA, 50% RB, 5 MHz, 64-QAM)	X	2.12	67.76	14.27	0.00	150.0	± 9.6 %
		Y	2.17	68.10	14.50		150.0	
		Z	2.25	67.49	14.68		150.0	
10160-CAC	LTE-FDD (SC-FDMA, 50% RB, 15 MHz, QPSK)	X	2.73	68.96	16.55	0.00	150.0	± 9.6 %
		Y	2.78	69.27	16.76		150.0	
		Z	2.78	68.34	16.22		150.0	
10161-CAC	LTE-FDD (SC-FDMA, 50% RB, 15 MHz, 16-QAM)	X	2.89	67.56	16.00	0.00	150.0	± 9.6 %
		Y	2.92	67.72	16.12		150.0	
		Z	2.97	67.14	15.84		150.0	
10162-CAC	LTE-FDD (SC-FDMA, 50% RB, 15 MHz, 64-QAM)	X	3.00	67.76	16.13	0.00	150.0	± 9.6 %
		Y	3.03	67.89	16.24		150.0	
		Z	3.08	67.27	15.94		150.0	
10166-CAD	LTE-FDD (SC-FDMA, 50% RB, 1.4 MHz, QPSK)	X	3.29	68.55	18.62	3.01	150.0	± 9.6 %
		Y	3.39	69.14	19.00		150.0	
		Z	3.56	68.77	18.74		150.0	
10167-CAD	LTE-FDD (SC-FDMA, 50% RB, 1.4 MHz, 16-QAM)	X	3.85	70.83	18.84	3.01	150.0	± 9.6 %
		Y	4.06	71.87	19.39		150.0	
		Z	4.27	71.19	19.04		150.0	

10168-CAD	LTE-FDD (SC-FDMA, 50% RB, 1.4 MHz, 64-QAM)	X	4.31	73.34	20.36	3.01	150.0	± 9.6 %
		Y	4.51	74.19	20.77		150.0	
		Z	4.72	73.40	20.38		150.0	
10169-CAC	LTE-FDD (SC-FDMA, 1 RB, 20 MHz, QPSK)	X	2.65	67.07	17.95	3.01	150.0	± 9.6 %
		Y	2.76	67.90	18.46		150.0	
		Z	2.95	68.18	18.47		150.0	
10170-CAC	LTE-FDD (SC-FDMA, 1 RB, 20 MHz, 16-QAM)	X	3.35	71.83	19.98	3.01	150.0	± 9.6 %
		Y	3.58	73.08	20.56		150.0	
		Z	3.90	73.37	20.58		150.0	
10171-AAC	LTE-FDD (SC-FDMA, 1 RB, 20 MHz, 64-QAM)	X	2.80	68.11	17.24	3.01	150.0	± 9.6 %
		Y	3.01	69.49	17.99		150.0	
		Z	3.23	69.44	17.85		150.0	
10172-CAC	LTE-TDD (SC-FDMA, 1 RB, 20 MHz, QPSK)	X	3.65	76.31	22.99	6.02	65.0	± 9.6 %
		Y	5.48	85.89	27.40		65.0	
		Z	5.55	83.03	25.87		65.0	
10173-CAC	LTE-TDD (SC-FDMA, 1 RB, 20 MHz, 16-QAM)	X	6.66	85.15	24.55	6.02	65.0	± 9.6 %
		Y	10.56	95.03	28.43		65.0	
		Z	12.26	94.72	28.10		65.0	
10174-CAC	LTE-TDD (SC-FDMA, 1 RB, 20 MHz, 64-QAM)	X	4.93	79.32	21.92	6.02	65.0	± 9.6 %
		Y	8.98	90.91	26.48		65.0	
		Z	8.81	87.78	25.30		65.0	
10175-CAD	LTE-FDD (SC-FDMA, 1 RB, 10 MHz, QPSK)	X	2.62	66.79	17.70	3.01	150.0	± 9.6 %
		Y	2.73	67.64	18.24		150.0	
		Z	2.91	67.87	18.21		150.0	
10176-CAD	LTE-FDD (SC-FDMA, 1 RB, 10 MHz, 16-QAM)	X	3.35	71.86	19.99	3.01	150.0	± 9.6 %
		Y	3.58	73.10	20.58		150.0	
		Z	3.90	73.39	20.59		150.0	
10177-CAF	LTE-FDD (SC-FDMA, 1 RB, 5 MHz, QPSK)	X	2.64	66.92	17.79	3.01	150.0	± 9.6 %
		Y	2.75	67.76	18.31		150.0	
		Z	2.94	68.03	18.32		150.0	
10178-CAD	LTE-FDD (SC-FDMA, 1 RB, 5 MHz, 16-QAM)	X	3.33	71.68	19.88	3.01	150.0	± 9.6 %
		Y	3.56	72.95	20.49		150.0	
		Z	3.86	73.15	20.45		150.0	
10179-CAD	LTE-FDD (SC-FDMA, 1 RB, 10 MHz, 64-QAM)	X	3.04	69.83	18.46	3.01	150.0	± 9.6 %
		Y	3.27	71.21	19.16		150.0	
		Z	3.53	71.24	19.06		150.0	
10180-CAD	LTE-FDD (SC-FDMA, 1 RB, 5 MHz, 64-QAM)	X	2.79	68.06	17.20	3.01	150.0	± 9.6 %
		Y	3.00	69.44	17.95		150.0	
		Z	3.23	69.37	17.80		150.0	
10181-CAC	LTE-FDD (SC-FDMA, 1 RB, 15 MHz, QPSK)	X	2.64	66.91	17.79	3.01	150.0	± 9.6 %
		Y	2.74	67.75	18.31		150.0	
		Z	2.93	68.01	18.31		150.0	
10182-CAC	LTE-FDD (SC-FDMA, 1 RB, 15 MHz, 16-QAM)	X	3.32	71.66	19.87	3.01	150.0	± 9.6 %
		Y	3.55	72.93	20.48		150.0	
		Z	3.85	73.13	20.44		150.0	
10183-AAB	LTE-FDD (SC-FDMA, 1 RB, 15 MHz, 64-QAM)	X	2.79	68.04	17.19	3.01	150.0	± 9.6 %
		Y	3.00	69.42	17.94		150.0	
		Z	3.22	69.35	17.79		150.0	

10184-CAD	LTE-FDD (SC-FDMA, 1 RB, 3 MHz, QPSK)	X	2.65	66.95	17.81	3.01	150.0	± 9.6 %
		Y	2.75	67.79	18.33		150.0	
		Z	2.95	68.05	18.33		150.0	
10185-CAD	LTE-FDD (SC-FDMA, 1 RB, 3 MHz, 16-QAM)	X	3.34	71.72	19.91	3.01	150.0	± 9.6 %
		Y	3.57	72.99	20.51		150.0	
		Z	3.87	73.20	20.48		150.0	
10186-AAD	LTE-FDD (SC-FDMA, 1 RB, 3 MHz, 64-QAM)	X	2.80	68.09	17.22	3.01	150.0	± 9.6 %
		Y	3.01	69.48	17.97		150.0	
		Z	3.23	69.41	17.82		150.0	
10187-CAD	LTE-FDD (SC-FDMA, 1 RB, 1.4 MHz, QPSK)	X	2.66	67.00	17.88	3.01	150.0	± 9.6 %
		Y	2.76	67.84	18.40		150.0	
		Z	2.95	68.09	18.39		150.0	
10188-CAD	LTE-FDD (SC-FDMA, 1 RB, 1.4 MHz, 16-QAM)	X	3.43	72.31	20.28	3.01	150.0	± 9.6 %
		Y	3.66	73.53	20.84		150.0	
		Z	4.00	73.86	20.87		150.0	
10189-AAD	LTE-FDD (SC-FDMA, 1 RB, 1.4 MHz, 64-QAM)	X	2.85	68.45	17.48	3.01	150.0	± 9.6 %
		Y	3.07	69.84	18.22		150.0	
		Z	3.30	69.81	18.09		150.0	
10193-CAB	IEEE 802.11n (HT Greenfield, 6.5 Mbps, BPSK)	X	4.48	66.73	16.24	0.00	150.0	± 9.6 %
		Y	4.49	66.78	16.30		150.0	
		Z	4.58	66.49	16.16		150.0	
10194-CAB	IEEE 802.11n (HT Greenfield, 39 Mbps, 16-QAM)	X	4.63	67.01	16.37	0.00	150.0	± 9.6 %
		Y	4.65	67.06	16.43		150.0	
		Z	4.76	66.82	16.28		150.0	
10195-CAB	IEEE 802.11n (HT Greenfield, 65 Mbps, 64-QAM)	X	4.67	67.04	16.38	0.00	150.0	± 9.6 %
		Y	4.69	67.09	16.44		150.0	
		Z	4.80	66.85	16.30		150.0	
10196-CAB	IEEE 802.11n (HT Mixed, 6.5 Mbps, BPSK)	X	4.47	66.77	16.24	0.00	150.0	± 9.6 %
		Y	4.48	66.82	16.30		150.0	
		Z	4.59	66.56	16.19		150.0	
10197-CAB	IEEE 802.11n (HT Mixed, 39 Mbps, 16-QAM)	X	4.64	67.02	16.38	0.00	150.0	± 9.6 %
		Y	4.66	67.08	16.44		150.0	
		Z	4.78	66.84	16.30		150.0	
10198-CAB	IEEE 802.11n (HT Mixed, 65 Mbps, 64-QAM)	X	4.67	67.05	16.39	0.00	150.0	± 9.6 %
		Y	4.68	67.10	16.45		150.0	
		Z	4.81	66.86	16.31		150.0	
10219-CAB	IEEE 802.11n (HT Mixed, 7.2 Mbps, BPSK)	X	4.42	66.79	16.21	0.00	150.0	± 9.6 %
		Y	4.44	66.84	16.27		150.0	
		Z	4.54	66.57	16.15		150.0	
10220-CAB	IEEE 802.11n (HT Mixed, 43.3 Mbps, 16-QAM)	X	4.64	66.99	16.36	0.00	150.0	± 9.6 %
		Y	4.65	67.04	16.42		150.0	
		Z	4.77	66.82	16.29		150.0	
10221-CAB	IEEE 802.11n (HT Mixed, 72.2 Mbps, 64-QAM)	X	4.68	66.98	16.38	0.00	150.0	± 9.6 %
		Y	4.69	67.03	16.44		150.0	
		Z	4.81	66.80	16.30		150.0	
10222-CAB	IEEE 802.11n (HT Mixed, 15 Mbps, BPSK)	X	5.03	67.11	16.49	0.00	150.0	± 9.6 %
		Y	5.04	67.15	16.55		150.0	
		Z	5.14	67.00	16.41		150.0	

10223-CAB	IEEE 802.11n (HT Mixed, 90 Mbps, 16-QAM)	X	5.33	67.33	16.62	0.00	150.0	± 9.6 %
		Y	5.34	67.38	16.68		150.0	
		Z	5.45	67.21	16.54		150.0	
10224-CAB	IEEE 802.11n (HT Mixed, 150 Mbps, 64-QAM)	X	5.07	67.22	16.48	0.00	150.0	± 9.6 %
		Y	5.09	67.26	16.53		150.0	
		Z	5.18	67.11	16.40		150.0	
10225-CAB	UMTS-FDD (HSPA+)	X	2.76	66.33	15.32	0.00	150.0	± 9.6 %
		Y	2.78	66.46	15.44		150.0	
		Z	2.85	65.93	15.34		150.0	
10226-CAA	LTE-TDD (SC-FDMA, 1 RB, 1.4 MHz, 16-QAM)	X	7.05	86.26	25.03	6.02	65.0	± 9.6 %
		Y	11.33	96.43	28.97		65.0	
		Z	13.18	96.17	28.66		65.0	
10227-CAA	LTE-TDD (SC-FDMA, 1 RB, 1.4 MHz, 64-QAM)	X	7.07	85.23	24.04	6.02	65.0	± 9.6 %
		Y	11.45	95.09	27.83		65.0	
		Z	12.76	94.16	27.40		65.0	
10228-CAA	LTE-TDD (SC-FDMA, 1 RB, 1.4 MHz, QPSK)	X	4.84	82.15	25.37	6.02	65.0	± 9.6 %
		Y	6.17	88.64	28.46		65.0	
		Z	7.76	90.12	28.51		65.0	
10229-CAB	LTE-TDD (SC-FDMA, 1 RB, 3 MHz, 16-QAM)	X	6.71	85.26	24.59	6.02	65.0	± 9.6 %
		Y	10.65	95.13	28.47		65.0	
		Z	12.36	94.84	28.14		65.0	
10230-CAB	LTE-TDD (SC-FDMA, 1 RB, 3 MHz, 64-QAM)	X	6.68	84.20	23.61	6.02	65.0	± 9.6 %
		Y	10.65	93.73	27.33		65.0	
		Z	11.94	92.89	26.92		65.0	
10231-CAB	LTE-TDD (SC-FDMA, 1 RB, 3 MHz, QPSK)	X	4.67	81.40	24.99	6.02	65.0	± 9.6 %
		Y	5.94	87.77	28.07		65.0	
		Z	7.43	89.17	28.10		65.0	
10232-CAC	LTE-TDD (SC-FDMA, 1 RB, 5 MHz, 16-QAM)	X	6.69	85.24	24.58	6.02	65.0	± 9.6 %
		Y	10.63	95.12	28.47		65.0	
		Z	12.34	94.82	28.14		65.0	
10233-CAC	LTE-TDD (SC-FDMA, 1 RB, 5 MHz, 64-QAM)	X	6.66	84.17	23.60	6.02	65.0	± 9.6 %
		Y	10.62	93.69	27.32		65.0	
		Z	11.91	92.86	26.91		65.0	
10234-CAC	LTE-TDD (SC-FDMA, 1 RB, 5 MHz, QPSK)	X	4.54	80.75	24.63	6.02	65.0	± 9.6 %
		Y	5.76	87.05	27.69		65.0	
		Z	7.17	88.32	27.68		65.0	
10235-CAC	LTE-TDD (SC-FDMA, 1 RB, 10 MHz, 16-QAM)	X	6.69	85.26	24.59	6.02	65.0	± 9.6 %
		Y	10.64	95.16	28.48		65.0	
		Z	12.35	94.85	28.15		65.0	
10236-CAC	LTE-TDD (SC-FDMA, 1 RB, 10 MHz, 64-QAM)	X	6.73	84.30	23.64	6.02	65.0	± 9.6 %
		Y	10.78	93.91	27.38		65.0	
		Z	12.05	93.03	26.96		65.0	
10237-CAC	LTE-TDD (SC-FDMA, 1 RB, 10 MHz, QPSK)	X	4.67	81.42	25.00	6.02	65.0	± 9.6 %
		Y	5.94	87.83	28.10		65.0	
		Z	7.43	89.21	28.12		65.0	
10238-CAC	LTE-TDD (SC-FDMA, 1 RB, 15 MHz, 16-QAM)	X	6.68	85.21	24.57	6.02	65.0	± 9.6 %
		Y	10.60	95.09	28.46		65.0	
		Z	12.31	94.79	28.13		65.0	

10239-CAC	LTE-TDD (SC-FDMA, 1 RB, 15 MHz, 64-QAM)	X	6.64	84.13	23.58	6.02	65.0	± 9.6 %
		Y	10.57	93.64	27.30		65.0	
		Z	11.87	92.82	26.90		65.0	
10240-CAC	LTE-TDD (SC-FDMA, 1 RB, 15 MHz, QPSK)	X	4.66	81.38	24.99	6.02	65.0	± 9.6 %
		Y	5.92	87.78	28.08		65.0	
		Z	7.41	89.16	28.10		65.0	
10241-CAA	LTE-TDD (SC-FDMA, 50% RB, 1.4 MHz, 16-QAM)	X	6.49	77.69	23.88	6.98	65.0	± 9.6 %
		Y	7.06	80.22	25.34		65.0	
		Z	7.33	78.75	24.61		65.0	
10242-CAA	LTE-TDD (SC-FDMA, 50% RB, 1.4 MHz, 64-QAM)	X	5.69	74.96	22.63	6.98	65.0	± 9.6 %
		Y	6.72	79.20	24.84		65.0	
		Z	6.48	76.10	23.39		65.0	
10243-CAA	LTE-TDD (SC-FDMA, 50% RB, 1.4 MHz, QPSK)	X	5.22	73.93	23.04	6.98	65.0	± 9.6 %
		Y	5.37	75.23	24.06		65.0	
		Z	5.30	72.76	22.72		65.0	
10244-CAB	LTE-TDD (SC-FDMA, 50% RB, 3 MHz, 16-QAM)	X	4.03	70.70	15.63	3.98	65.0	± 9.6 %
		Y	4.63	73.27	17.01		65.0	
		Z	5.80	76.12	19.17		65.0	
10245-CAB	LTE-TDD (SC-FDMA, 50% RB, 3 MHz, 64-QAM)	X	3.94	70.12	15.32	3.98	65.0	± 9.6 %
		Y	4.47	72.48	16.60		65.0	
		Z	5.67	75.49	18.85		65.0	
10246-CAB	LTE-TDD (SC-FDMA, 50% RB, 3 MHz, QPSK)	X	4.17	75.16	18.15	3.98	65.0	± 9.6 %
		Y	5.29	79.64	20.23		65.0	
		Z	5.81	80.17	21.10		65.0	
10247-CAC	LTE-TDD (SC-FDMA, 50% RB, 5 MHz, 16-QAM)	X	4.10	71.58	17.29	3.98	65.0	± 9.6 %
		Y	4.43	73.43	18.37		65.0	
		Z	4.92	74.07	19.21		65.0	
10248-CAC	LTE-TDD (SC-FDMA, 50% RB, 5 MHz, 64-QAM)	X	4.07	70.96	16.98	3.98	65.0	± 9.6 %
		Y	4.37	72.65	17.99		65.0	
		Z	4.90	73.42	18.88		65.0	
10249-CAC	LTE-TDD (SC-FDMA, 50% RB, 5 MHz, QPSK)	X	5.33	79.24	20.92	3.98	65.0	± 9.6 %
		Y	6.73	84.01	23.05		65.0	
		Z	6.62	82.34	22.76		65.0	
10250-CAC	LTE-TDD (SC-FDMA, 50% RB, 10 MHz, 16-QAM)	X	4.99	74.32	20.40	3.98	65.0	± 9.6 %
		Y	5.24	75.79	21.30		65.0	
		Z	5.59	75.60	21.35		65.0	
10251-CAC	LTE-TDD (SC-FDMA, 50% RB, 10 MHz, 64-QAM)	X	4.75	72.14	19.02	3.98	65.0	± 9.6 %
		Y	4.99	73.56	19.92		65.0	
		Z	5.35	73.44	20.02		65.0	
10252-CAC	LTE-TDD (SC-FDMA, 50% RB, 10 MHz, QPSK)	X	5.62	79.05	22.01	3.98	65.0	± 9.6 %
		Y	6.48	82.42	23.65		65.0	
		Z	6.49	80.72	22.96		65.0	
10253-CAC	LTE-TDD (SC-FDMA, 50% RB, 15 MHz, 16-QAM)	X	4.91	71.43	19.12	3.98	65.0	± 9.6 %
		Y	5.09	72.60	19.93		65.0	
		Z	5.40	72.41	19.86		65.0	
10254-CAC	LTE-TDD (SC-FDMA, 50% RB, 15 MHz, 64-QAM)	X	5.23	72.40	19.88	3.98	65.0	± 9.6 %
		Y	5.41	73.49	20.63		65.0	
		Z	5.73	73.30	20.57		65.0	

10255-CAC	LTE-TDD (SC-FDMA, 50% RB, 15 MHz, QPSK)	X	5.37	75.82	20.95	3.98	65.0	± 9.6 %
		Y	5.81	77.90	22.11		65.0	
		Z	5.98	76.90	21.60		65.0	
10256-CAA	LTE-TDD (SC-FDMA, 100% RB, 1.4 MHz, 16-QAM)	X	2.95	66.44	12.43	3.98	65.0	± 9.6 %
		Y	3.25	68.14	13.47		65.0	
		Z	4.63	72.57	16.66		65.0	
10257-CAA	LTE-TDD (SC-FDMA, 100% RB, 1.4 MHz, 64-QAM)	X	2.90	65.89	12.05	3.98	65.0	± 9.6 %
		Y	3.14	67.36	12.98		65.0	
		Z	4.49	71.73	16.18		65.0	
10258-CAA	LTE-TDD (SC-FDMA, 100% RB, 1.4 MHz, QPSK)	X	2.90	69.51	14.64	3.98	65.0	± 9.6 %
		Y	3.44	72.54	16.25		65.0	
		Z	4.52	75.89	18.60		65.0	
10259-CAB	LTE-TDD (SC-FDMA, 100% RB, 3 MHz, 16-QAM)	X	4.46	72.72	18.47	3.98	65.0	± 9.6 %
		Y	4.78	74.47	19.50		65.0	
		Z	5.19	74.62	19.97		65.0	
10260-CAB	LTE-TDD (SC-FDMA, 100% RB, 3 MHz, 64-QAM)	X	4.49	72.43	18.33	3.98	65.0	± 9.6 %
		Y	4.79	74.08	19.32		65.0	
		Z	5.22	74.34	19.84		65.0	
10261-CAB	LTE-TDD (SC-FDMA, 100% RB, 3 MHz, QPSK)	X	5.17	78.27	21.02	3.98	65.0	± 9.6 %
		Y	6.16	82.12	22.85		65.0	
		Z	6.14	80.53	22.44		65.0	
10262-CAC	LTE-TDD (SC-FDMA, 100% RB, 5 MHz, 16-QAM)	X	4.98	74.25	20.35	3.98	65.0	± 9.6 %
		Y	5.23	75.73	21.26		65.0	
		Z	5.58	75.55	21.31		65.0	
10263-CAC	LTE-TDD (SC-FDMA, 100% RB, 5 MHz, 64-QAM)	X	4.74	72.12	19.01	3.98	65.0	± 9.6 %
		Y	4.98	73.53	19.91		65.0	
		Z	5.34	73.42	20.01		65.0	
10264-CAC	LTE-TDD (SC-FDMA, 100% RB, 5 MHz, QPSK)	X	5.56	78.83	21.90	3.98	65.0	± 9.6 %
		Y	6.41	82.18	23.54		65.0	
		Z	6.42	80.51	22.86		65.0	
10265-CAC	LTE-TDD (SC-FDMA, 100% RB, 10 MHz, 16-QAM)	X	4.98	71.84	19.37	3.98	65.0	± 9.6 %
		Y	5.18	73.09	20.20		65.0	
		Z	5.53	73.00	20.12		65.0	
10266-CAC	LTE-TDD (SC-FDMA, 100% RB, 10 MHz, 64-QAM)	X	5.34	72.91	20.22	3.98	65.0	± 9.6 %
		Y	5.53	74.04	20.98		65.0	
		Z	5.88	73.92	20.89		65.0	
10267-CAC	LTE-TDD (SC-FDMA, 100% RB, 10 MHz, QPSK)	X	5.64	76.53	21.06	3.98	65.0	± 9.6 %
		Y	6.16	78.78	22.27		65.0	
		Z	6.34	77.78	21.72		65.0	
10268-CAC	LTE-TDD (SC-FDMA, 100% RB, 15 MHz, 16-QAM)	X	5.63	71.94	19.85	3.98	65.0	± 9.6 %
		Y	5.78	72.88	20.51		65.0	
		Z	6.14	72.88	20.41		65.0	
10269-CAC	LTE-TDD (SC-FDMA, 100% RB, 15 MHz, 64-QAM)	X	5.64	71.57	19.72	3.98	65.0	± 9.6 %
		Y	5.77	72.45	20.36		65.0	
		Z	6.12	72.44	20.27		65.0	
10270-CAC	LTE-TDD (SC-FDMA, 100% RB, 15 MHz, QPSK)	X	5.66	74.09	20.17	3.98	65.0	± 9.6 %
		Y	5.94	75.48	21.01		65.0	
		Z	6.22	75.05	20.69		65.0	

10274-CAB	UMTS-FDD (HSUPA, Subtest 5, 3GPP Rel8.10)	X	2.58	66.84	15.32	0.00	150.0	± 9.6 %
		Y	2.61	67.05	15.49		150.0	
		Z	2.61	66.19	15.19		150.0	
10275-CAB	UMTS-FDD (HSUPA, Subtest 5, 3GPP Rel8.4)	X	1.62	68.33	15.81	0.00	150.0	± 9.6 %
		Y	1.68	69.01	16.23		150.0	
		Z	1.61	67.33	15.34		150.0	
10277-CAA	PHS (QPSK)	X	1.71	60.26	5.85	9.03	50.0	± 9.6 %
		Y	1.46	60.00	5.35		50.0	
		Z	2.08	61.87	7.57		50.0	
10278-CAA	PHS (QPSK, BW 884MHz, Rolloff 0.5)	X	3.48	68.77	13.21	9.03	50.0	± 9.6 %
		Y	3.86	71.42	14.38		50.0	
		Z	7.61	81.06	19.61		50.0	
10279-CAA	PHS (QPSK, BW 884MHz, Rolloff 0.38)	X	3.59	69.09	13.42	9.03	50.0	± 9.6 %
		Y	4.03	71.88	14.65		50.0	
		Z	7.80	81.31	19.76		50.0	
10290-AAB	CDMA2000, RC1, SO55, Full Rate	X	1.38	68.75	13.54	0.00	150.0	± 9.6 %
		Y	1.49	69.81	14.11		150.0	
		Z	1.48	68.40	14.11		150.0	
10291-AAB	CDMA2000, RC3, SO55, Full Rate	X	0.81	66.18	12.25	0.00	150.0	± 9.6 %
		Y	0.88	67.15	12.85		150.0	
		Z	0.85	65.51	12.62		150.0	
10292-AAB	CDMA2000, RC3, SO32, Full Rate	X	1.25	72.63	15.60	0.00	150.0	± 9.6 %
		Y	1.48	75.02	16.70		150.0	
		Z	1.05	69.24	14.85		150.0	
10293-AAB	CDMA2000, RC3, SO3, Full Rate	X	3.55	87.18	21.36	0.00	150.0	± 9.6 %
		Y	4.57	90.90	22.67		150.0	
		Z	1.55	74.98	17.80		150.0	
10295-AAB	CDMA2000, RC1, SO3, 1/8th Rate 25 fr.	X	10.90	87.79	24.10	9.03	50.0	± 9.6 %
		Y	17.38	97.96	27.91		50.0	
		Z	9.27	86.92	25.25		50.0	
10297-AAB	LTE-FDD (SC-FDMA, 50% RB, 20 MHz, QPSK)	X	2.71	69.84	16.83	0.00	150.0	± 9.6 %
		Y	2.77	70.21	17.06		150.0	
		Z	2.77	69.29	16.46		150.0	
10298-AAC	LTE-FDD (SC-FDMA, 50% RB, 3 MHz, QPSK)	X	1.47	67.49	13.62	0.00	150.0	± 9.6 %
		Y	1.54	68.13	14.02		150.0	
		Z	1.61	67.49	14.26		150.0	
10299-AAC	LTE-FDD (SC-FDMA, 50% RB, 3 MHz, 16-QAM)	X	1.91	66.04	11.93	0.00	150.0	± 9.6 %
		Y	2.08	67.06	12.49		150.0	
		Z	2.55	68.88	14.29		150.0	
10300-AAC	LTE-FDD (SC-FDMA, 50% RB, 3 MHz, 64-QAM)	X	1.52	62.84	9.56	0.00	150.0	± 9.6 %
		Y	1.60	63.32	9.89		150.0	
		Z	2.01	64.97	11.67		150.0	
10301-AAA	IEEE 802.16e WiMAX (29:18, 5ms, 10MHz, QPSK, PUSC)	X	4.49	64.94	17.15	4.17	50.0	± 9.6 %
		Y	4.51	65.12	17.33		50.0	
		Z	4.77	65.09	17.35		50.0	
10302-AAA	IEEE 802.16e WiMAX (29:18, 5ms, 10MHz, QPSK, PUSC, 3 CTRL symbols)	X	4.98	65.58	17.87	4.96	50.0	± 9.6 %
		Y	5.02	65.83	18.08		50.0	
		Z	5.23	65.61	18.00		50.0	

10303-AAA	IEEE 802.16e WiMAX (31:15, 5ms, 10MHz, 64QAM, PUSC)	X	4.72	65.17	17.66	4.96	50.0	± 9.6 %
		Y	4.76	65.39	17.86		50.0	
		Z	4.98	65.24	17.83		50.0	
10304-AAA	IEEE 802.16e WiMAX (29:18, 5ms, 10MHz, 64QAM, PUSC)	X	4.56	65.16	17.23	4.17	50.0	± 9.6 %
		Y	4.60	65.38	17.42		50.0	
		Z	4.79	65.14	17.34		50.0	
10305-AAA	IEEE 802.16e WiMAX (31:15, 10ms, 10MHz, 64QAM, PUSC, 15 symbols)	X	4.06	66.26	18.68	6.02	35.0	± 9.6 %
		Y	3.98	66.05	18.73		35.0	
		Z	4.32	66.47	19.19		35.0	
10306-AAA	IEEE 802.16e WiMAX (29:18, 10ms, 10MHz, 64QAM, PUSC, 18 symbols)	X	4.43	65.65	18.52	6.02	35.0	± 9.6 %
		Y	4.40	65.62	18.63		35.0	
		Z	4.69	65.80	18.88		35.0	
10307-AAA	IEEE 802.16e WiMAX (29:18, 10ms, 10MHz, QPSK, PUSC, 18 symbols)	X	4.31	65.69	18.43	6.02	35.0	± 9.6 %
		Y	4.27	65.62	18.52		35.0	
		Z	4.59	65.95	18.85		35.0	
10308-AAA	IEEE 802.16e WiMAX (29:18, 10ms, 10MHz, 16QAM, PUSC)	X	4.28	65.86	18.56	6.02	35.0	± 9.6 %
		Y	4.24	65.78	18.65		35.0	
		Z	4.55	66.08	18.95		35.0	
10309-AAA	IEEE 802.16e WiMAX (29:18, 10ms, 10MHz, 16QAM, AMC 2x3, 18 symbols)	X	4.47	65.79	18.63	6.02	35.0	± 9.6 %
		Y	4.44	65.78	18.76		35.0	
		Z	4.75	66.03	19.03		35.0	
10310-AAA	IEEE 802.16e WiMAX (29:18, 10ms, 10MHz, QPSK, AMC 2x3, 18 symbols)	X	4.38	65.69	18.49	6.02	35.0	± 9.6 %
		Y	4.34	65.63	18.59		35.0	
		Z	4.64	65.84	18.85		35.0	
10311-AAB	LTE-FDD (SC-FDMA, 100% RB, 15 MHz, QPSK)	X	3.08	69.08	16.47	0.00	150.0	± 9.6 %
		Y	3.14	69.40	16.66		150.0	
		Z	3.12	68.62	16.13		150.0	
10313-AAA	iDEN 1:3	X	2.89	72.65	16.29	6.99	70.0	± 9.6 %
		Y	4.19	78.79	18.89		70.0	
		Z	4.02	76.71	18.18		70.0	
10314-AAA	iDEN 1:6	X	5.30	83.78	23.47	10.00	30.0	± 9.6 %
		Y	6.55	89.94	26.15		30.0	
		Z	6.97	88.50	25.50		30.0	
10315-AAB	IEEE 802.11b WiFi 2.4 GHz (DSSS, 1 Mbps, 96pc duty cycle)	X	1.08	63.77	15.30	0.17	150.0	± 9.6 %
		Y	1.10	64.11	15.62		150.0	
		Z	1.08	63.32	14.99		150.0	
10316-AAB	IEEE 802.11g WiFi 2.4 GHz (ERP-OFDM, 6 Mbps, 96pc duty cycle)	X	4.51	66.68	16.32	0.17	150.0	± 9.6 %
		Y	4.53	66.78	16.42		150.0	
		Z	4.64	66.54	16.30		150.0	
10317-AAB	IEEE 802.11a WiFi 5 GHz (OFDM, 6 Mbps, 96pc duty cycle)	X	4.51	66.68	16.32	0.17	150.0	± 9.6 %
		Y	4.53	66.78	16.42		150.0	
		Z	4.64	66.54	16.30		150.0	
10400-AAC	IEEE 802.11ac WiFi (20MHz, 64-QAM, 99pc duty cycle)	X	4.61	67.03	16.35	0.00	150.0	± 9.6 %
		Y	4.63	67.11	16.42		150.0	
		Z	4.76	66.86	16.27		150.0	
10401-AAC	IEEE 802.11ac WiFi (40MHz, 64-QAM, 99pc duty cycle)	X	5.34	67.18	16.51	0.00	150.0	± 9.6 %
		Y	5.36	67.26	16.59		150.0	
		Z	5.46	67.09	16.45		150.0	

10402-AAC	IEEE 802.11ac WiFi (80MHz, 64-QAM, 99pc duty cycle)	X	5.59	67.45	16.52	0.00	150.0	± 9.6 %
		Y	5.60	67.49	16.57		150.0	
		Z	5.71	67.42	16.48		150.0	
10403-AAB	CDMA2000 (1xEV-DO, Rev. 0)	X	1.38	68.75	13.54	0.00	115.0	± 9.6 %
		Y	1.49	69.81	14.11		115.0	
		Z	1.48	68.40	14.11		115.0	
10404-AAB	CDMA2000 (1xEV-DO, Rev. A)	X	1.38	68.75	13.54	0.00	115.0	± 9.6 %
		Y	1.49	69.81	14.11		115.0	
		Z	1.48	68.40	14.11		115.0	
10406-AAB	CDMA2000, RC3, SO32, SCH0, Full Rate	X	17.35	99.43	24.90	0.00	100.0	± 9.6 %
		Y	63.25	115.82	28.80		100.0	
		Z	11.61	93.88	24.12		100.0	
10410-AAB	LTE-TDD (SC-FDMA, 1 RB, 10 MHz, QPSK, UL Subframe=2,3,4,7,8,9)	X	8.36	91.25	22.62	3.23	80.0	± 9.6 %
		Y	100.00	127.16	32.13		80.0	
		Z	100.00	125.70	32.09		80.0	
10415-AAA	IEEE 802.11b WiFi 2.4 GHz (DSSS, 1 Mbps, 99pc duty cycle)	X	1.03	63.22	14.88	0.00	150.0	± 9.6 %
		Y	1.04	63.49	15.13		150.0	
		Z	1.02	62.64	14.46		150.0	
10416-AAA	IEEE 802.11g WiFi 2.4 GHz (ERP-OFDM, 6 Mbps, 99pc duty cycle)	X	4.48	66.75	16.31	0.00	150.0	± 9.6 %
		Y	4.49	66.81	16.37		150.0	
		Z	4.59	66.53	16.22		150.0	
10417-AAA	IEEE 802.11a/h WiFi 5 GHz (OFDM, 6 Mbps, 99pc duty cycle)	X	4.48	66.75	16.31	0.00	150.0	± 9.6 %
		Y	4.49	66.81	16.37		150.0	
		Z	4.59	66.53	16.22		150.0	
10418-AAA	IEEE 802.11g WiFi 2.4 GHz (DSSS-OFDM, 6 Mbps, 99pc duty cycle, Long preamble)	X	4.47	66.94	16.35	0.00	150.0	± 9.6 %
		Y	4.48	67.00	16.41		150.0	
		Z	4.58	66.68	16.24		150.0	
10419-AAA	IEEE 802.11g WiFi 2.4 GHz (DSSS-OFDM, 6 Mbps, 99pc duty cycle, Short preamble)	X	4.49	66.88	16.34	0.00	150.0	± 9.6 %
		Y	4.50	66.93	16.40		150.0	
		Z	4.60	66.63	16.24		150.0	
10422-AAA	IEEE 802.11n (HT Greenfield, 7.2 Mbps, BPSK)	X	4.60	66.86	16.35	0.00	150.0	± 9.6 %
		Y	4.61	66.91	16.41		150.0	
		Z	4.72	66.64	16.26		150.0	
10423-AAA	IEEE 802.11n (HT Greenfield, 43.3 Mbps, 16-QAM)	X	4.74	67.14	16.45	0.00	150.0	± 9.6 %
		Y	4.76	67.20	16.51		150.0	
		Z	4.89	66.97	16.38		150.0	
10424-AAA	IEEE 802.11n (HT Greenfield, 72.2 Mbps, 64-QAM)	X	4.67	67.10	16.43	0.00	150.0	± 9.6 %
		Y	4.68	67.15	16.49		150.0	
		Z	4.81	66.91	16.35		150.0	
10425-AAA	IEEE 802.11n (HT Greenfield, 15 Mbps, BPSK)	X	5.29	67.34	16.60	0.00	150.0	± 9.6 %
		Y	5.30	67.39	16.66		150.0	
		Z	5.42	67.29	16.55		150.0	
10426-AAA	IEEE 802.11n (HT Greenfield, 90 Mbps, 16-QAM)	X	5.31	67.43	16.64	0.00	150.0	± 9.6 %
		Y	5.32	67.48	16.70		150.0	
		Z	5.43	67.30	16.56		150.0	

10427-AAA	IEEE 802.11n (HT Greenfield, 150 Mbps, 64-QAM)	X	5.30	67.32	16.58	0.00	150.0	± 9.6 %
		Y	5.31	67.37	16.64		150.0	
		Z	5.44	67.28	16.54		150.0	
10430-AAA	LTE-FDD (OFDMA, 5 MHz, E-TM 3.1)	X	4.41	72.30	18.78	0.00	150.0	± 9.6 %
		Y	4.28	71.61	18.44		150.0	
		Z	4.35	70.84	18.35		150.0	
10431-AAA	LTE-FDD (OFDMA, 10 MHz, E-TM 3.1)	X	4.12	67.35	16.27	0.00	150.0	± 9.6 %
		Y	4.14	67.43	16.34		150.0	
		Z	4.27	67.06	16.22		150.0	
10432-AAA	LTE-FDD (OFDMA, 15 MHz, E-TM 3.1)	X	4.43	67.18	16.37	0.00	150.0	± 9.6 %
		Y	4.45	67.24	16.44		150.0	
		Z	4.58	66.95	16.29		150.0	
10433-AAA	LTE-FDD (OFDMA, 20 MHz, E-TM 3.1)	X	4.69	67.13	16.45	0.00	150.0	± 9.6 %
		Y	4.70	67.18	16.51		150.0	
		Z	4.82	66.95	16.37		150.0	
10434-AAA	W-CDMA (BS Test Model 1, 64 DPCH)	X	4.58	73.43	18.77	0.00	150.0	± 9.6 %
		Y	4.41	72.61	18.39		150.0	
		Z	4.46	71.72	18.35		150.0	
10435-AAB	LTE-TDD (SC-FDMA, 1 RB, 20 MHz, QPSK, UL Subframe=2,3,4,7,8,9)	X	7.84	90.24	22.26	3.23	80.0	± 9.6 %
		Y	100.00	126.90	32.00		80.0	
		Z	100.00	125.48	31.98		80.0	
10447-AAA	LTE-FDD (OFDMA, 5 MHz, E-TM 3.1, Clipping 44%)	X	3.40	67.35	15.41	0.00	150.0	± 9.6 %
		Y	3.42	67.47	15.52		150.0	
		Z	3.56	67.03	15.56		150.0	
10448-AAA	LTE-FDD (OFDMA, 10 MHz, E-TM 3.1, Clipping 44%)	X	3.98	67.14	16.14	0.00	150.0	± 9.6 %
		Y	4.00	67.22	16.21		150.0	
		Z	4.11	66.83	16.08		150.0	
10449-AAA	LTE-FDD (OFDMA, 15 MHz, E-TM 3.1, Clipping 44%)	X	4.26	67.02	16.27	0.00	150.0	± 9.6 %
		Y	4.28	67.08	16.34		150.0	
		Z	4.38	66.77	16.19		150.0	
10450-AAA	LTE-FDD (OFDMA, 20 MHz, E-TM 3.1, Clipping 44%)	X	4.47	66.91	16.31	0.00	150.0	± 9.6 %
		Y	4.48	66.96	16.37		150.0	
		Z	4.58	66.71	16.22		150.0	
10451-AAA	W-CDMA (BS Test Model 1, 64 DPCH, Clipping 44%)	X	3.25	67.38	14.88	0.00	150.0	± 9.6 %
		Y	3.28	67.53	15.01		150.0	
		Z	3.46	67.22	15.21		150.0	
10456-AAA	IEEE 802.11ac WiFi (160MHz, 64-QAM, 99pc duty cycle)	X	6.22	67.99	16.81	0.00	150.0	± 9.6 %
		Y	6.22	68.02	16.86		150.0	
		Z	6.28	67.84	16.71		150.0	
10457-AAA	UMTS-FDD (DC-HSDPA)	X	3.78	65.43	16.02	0.00	150.0	± 9.6 %
		Y	3.79	65.48	16.08		150.0	
		Z	3.83	65.16	15.92		150.0	
10458-AAA	CDMA2000 (1xEV-DO, Rev. B, 2 carriers)	X	3.02	66.44	14.01	0.00	150.0	± 9.6 %
		Y	3.06	66.64	14.18		150.0	
		Z	3.28	66.54	14.63		150.0	
10459-AAA	CDMA2000 (1xEV-DO, Rev. B, 3 carriers)	X	4.18	65.23	15.36	0.00	150.0	± 9.6 %
		Y	4.18	65.21	15.41		150.0	
		Z	4.47	65.25	15.75		150.0	

10460-AAA	UMTS-FDD (WCDMA, AMR)	X	0.93	68.87	16.62	0.00	150.0	± 9.6 %
		Y	1.00	70.16	17.38		150.0	
		Z	0.88	67.06	15.60		150.0	
10461-AAA	LTE-TDD (SC-FDMA, 1 RB, 1.4 MHz, QPSK, UL Subframe=2,3,4,7,8,9)	X	4.32	84.19	21.37	3.29	80.0	± 9.6 %
		Y	46.98	120.39	31.74		80.0	
		Z	70.92	123.84	32.55		80.0	
10462-AAA	LTE-TDD (SC-FDMA, 1 RB, 1.4 MHz, 16-QAM, UL Subframe=2,3,4,7,8,9)	X	0.93	61.17	8.92	3.23	80.0	± 9.6 %
		Y	1.50	66.22	11.48		80.0	
		Z	4.18	75.74	15.77		80.0	
10463-AAA	LTE-TDD (SC-FDMA, 1 RB, 1.4 MHz, 64-QAM, UL Subframe=2,3,4,7,8,9)	X	0.83	60.00	7.74	3.23	80.0	± 9.6 %
		Y	0.90	60.95	8.47		80.0	
		Z	1.89	66.55	11.77		80.0	
10464-AAA	LTE-TDD (SC-FDMA, 1 RB, 3 MHz, QPSK, UL Subframe=2,3,4,7,8,9)	X	3.27	79.79	19.27	3.23	80.0	± 9.6 %
		Y	44.63	117.13	30.10		80.0	
		Z	63.16	119.86	30.88		80.0	
10465-AAA	LTE-TDD (SC-FDMA, 1 RB, 3 MHz, 16-QAM, UL Subframe=2,3,4,7,8,9)	X	0.88	60.65	8.58	3.23	80.0	± 9.6 %
		Y	1.28	64.64	10.73		80.0	
		Z	2.98	72.01	14.38		80.0	
10466-AAA	LTE-TDD (SC-FDMA, 1 RB, 3 MHz, 64-QAM, UL Subframe=2,3,4,7,8,9)	X	0.83	60.00	7.69	3.23	80.0	± 9.6 %
		Y	0.85	60.44	8.16		80.0	
		Z	1.66	65.17	11.12		80.0	
10467-AAB	LTE-TDD (SC-FDMA, 1 RB, 5 MHz, QPSK, UL Subframe=2,3,4,7,8,9)	X	3.54	80.96	19.70	3.23	80.0	± 9.6 %
		Y	60.93	121.68	31.18		80.0	
		Z	84.88	124.19	31.89		80.0	
10468-AAB	LTE-TDD (SC-FDMA, 1 RB, 5 MHz, 16-QAM, UL Subframe=2,3,4,7,8,9)	X	0.89	60.80	8.68	3.23	80.0	± 9.6 %
		Y	1.33	65.06	10.94		80.0	
		Z	3.21	72.86	14.71		80.0	
10469-AAB	LTE-TDD (SC-FDMA, 1 RB, 5 MHz, 64-QAM, UL Subframe=2,3,4,7,8,9)	X	0.83	60.00	7.69	3.23	80.0	± 9.6 %
		Y	0.85	60.46	8.17		80.0	
		Z	1.66	65.20	11.14		80.0	
10470-AAB	LTE-TDD (SC-FDMA, 1 RB, 10 MHz, QPSK, UL Subframe=2,3,4,7,8,9)	X	3.54	80.99	19.71	3.23	80.0	± 9.6 %
		Y	63.11	122.20	31.29		80.0	
		Z	86.48	124.48	31.95		80.0	
10471-AAB	LTE-TDD (SC-FDMA, 1 RB, 10 MHz, 16-QAM, UL Subframe=2,3,4,7,8,9)	X	0.88	60.76	8.65	3.23	80.0	± 9.6 %
		Y	1.32	64.98	10.89		80.0	
		Z	3.18	72.76	14.66		80.0	
10472-AAB	LTE-TDD (SC-FDMA, 1 RB, 10 MHz, 64-QAM, UL Subframe=2,3,4,7,8,9)	X	0.83	60.00	7.68	3.23	80.0	± 9.6 %
		Y	0.84	60.42	8.13		80.0	
		Z	1.65	65.15	11.10		80.0	
10473-AAB	LTE-TDD (SC-FDMA, 1 RB, 15 MHz, QPSK, UL Subframe=2,3,4,7,8,9)	X	3.52	80.93	19.68	3.23	80.0	± 9.6 %
		Y	62.71	122.07	31.26		80.0	
		Z	85.93	124.36	31.91		80.0	
10474-AAB	LTE-TDD (SC-FDMA, 1 RB, 15 MHz, 16-QAM, UL Subframe=2,3,4,7,8,9)	X	0.88	60.74	8.64	3.23	80.0	± 9.6 %
		Y	1.31	64.94	10.87		80.0	
		Z	3.15	72.67	14.63		80.0	
10475-AAB	LTE-TDD (SC-FDMA, 1 RB, 15 MHz, 64-QAM, UL Subframe=2,3,4,7,8,9)	X	0.83	60.00	7.68	3.23	80.0	± 9.6 %
		Y	0.84	60.40	8.12		80.0	
		Z	1.64	65.11	11.08		80.0	

10477-AAB	LTE-TDD (SC-FDMA, 1 RB, 20 MHz, 16-QAM, UL Subframe=2,3,4,7,8,9)	X	0.87	60.61	8.55	3.23	80.0	± 9.6 %
		Y	1.27	64.59	10.69		80.0	
		Z	2.97	71.99	14.36		80.0	
10478-AAB	LTE-TDD (SC-FDMA, 1 RB, 20 MHz, 64-QAM, UL Subframe=2,3,4,7,8,9)	X	0.83	60.00	7.67	3.23	80.0	± 9.6 %
		Y	0.84	60.37	8.09		80.0	
		Z	1.63	65.04	11.04		80.0	
10479-AAA	LTE-TDD (SC-FDMA, 50% RB, 1.4 MHz, QPSK, UL Subframe=2,3,4,7,8,9)	X	4.53	79.52	20.39	3.23	80.0	± 9.6 %
		Y	7.80	88.47	23.78		80.0	
		Z	5.78	82.49	22.28		80.0	
10480-AAA	LTE-TDD (SC-FDMA, 50% RB, 1.4 MHz, 16-QAM, UL Subframe=2,3,4,7,8,9)	X	3.53	72.09	15.68	3.23	80.0	± 9.6 %
		Y	6.36	79.96	18.76		80.0	
		Z	6.52	79.72	19.55		80.0	
10481-AAA	LTE-TDD (SC-FDMA, 50% RB, 1.4 MHz, 64-QAM, UL Subframe=2,3,4,7,8,9)	X	2.81	68.83	13.98	3.23	80.0	± 9.6 %
		Y	4.53	74.98	16.60		80.0	
		Z	5.48	76.73	18.13		80.0	
10482-AAA	LTE-TDD (SC-FDMA, 50% RB, 3 MHz, QPSK, UL Subframe=2,3,4,7,8,9)	X	2.20	68.90	15.09	2.23	80.0	± 9.6 %
		Y	2.93	73.22	17.16		80.0	
		Z	2.97	72.34	17.43		80.0	
10483-AAA	LTE-TDD (SC-FDMA, 50% RB, 3 MHz, 16-QAM, UL Subframe=2,3,4,7,8,9)	X	2.35	65.97	12.90	2.23	80.0	± 9.6 %
		Y	3.02	69.40	14.64		80.0	
		Z	4.23	73.30	17.24		80.0	
10484-AAA	LTE-TDD (SC-FDMA, 50% RB, 3 MHz, 64-QAM, UL Subframe=2,3,4,7,8,9)	X	2.28	65.32	12.60	2.23	80.0	± 9.6 %
		Y	2.83	68.32	14.18		80.0	
		Z	3.99	72.23	16.81		80.0	
10485-AAB	LTE-TDD (SC-FDMA, 50% RB, 5 MHz, QPSK, UL Subframe=2,3,4,7,8,9)	X	2.68	71.36	17.35	2.23	80.0	± 9.6 %
		Y	3.27	74.89	19.08		80.0	
		Z	3.17	72.95	18.56		80.0	
10486-AAB	LTE-TDD (SC-FDMA, 50% RB, 5 MHz, 16-QAM, UL Subframe=2,3,4,7,8,9)	X	2.64	67.61	15.00	2.23	80.0	± 9.6 %
		Y	2.99	69.69	16.14		80.0	
		Z	3.15	69.34	16.51		80.0	
10487-AAB	LTE-TDD (SC-FDMA, 50% RB, 5 MHz, 64-QAM, UL Subframe=2,3,4,7,8,9)	X	2.64	67.21	14.79	2.23	80.0	± 9.6 %
		Y	2.96	69.13	15.87		80.0	
		Z	3.15	68.96	16.33		80.0	
10488-AAB	LTE-TDD (SC-FDMA, 50% RB, 10 MHz, QPSK, UL Subframe=2,3,4,7,8,9)	X	3.00	70.76	18.02	2.23	80.0	± 9.6 %
		Y	3.34	72.92	19.20		80.0	
		Z	3.42	71.88	18.69		80.0	
10489-AAB	LTE-TDD (SC-FDMA, 50% RB, 10 MHz, 16-QAM, UL Subframe=2,3,4,7,8,9)	X	3.07	67.95	16.69	2.23	80.0	± 9.6 %
		Y	3.24	69.09	17.42		80.0	
		Z	3.37	68.53	17.27		80.0	
10490-AAB	LTE-TDD (SC-FDMA, 50% RB, 10 MHz, 64-QAM, UL Subframe=2,3,4,7,8,9)	X	3.16	67.82	16.63	2.23	80.0	± 9.6 %
		Y	3.32	68.90	17.33		80.0	
		Z	3.47	68.38	17.21		80.0	
10491-AAB	LTE-TDD (SC-FDMA, 50% RB, 15 MHz, QPSK, UL Subframe=2,3,4,7,8,9)	X	3.29	69.57	17.67	2.23	80.0	± 9.6 %
		Y	3.53	71.04	18.54		80.0	
		Z	3.67	70.46	18.17		80.0	
10492-AAB	LTE-TDD (SC-FDMA, 50% RB, 15 MHz, 16-QAM, UL Subframe=2,3,4,7,8,9)	X	3.43	67.31	16.78	2.23	80.0	± 9.6 %
		Y	3.55	68.11	17.34		80.0	
		Z	3.72	67.80	17.20		80.0	

10493-AAB	LTE-TDD (SC-FDMA, 50% RB, 15 MHz, 64-QAM, UL Subframe=2,3,4,7,8,9)	X	3.50	67.21	16.74	2.23	80.0	± 9.6 %
		Y	3.62	67.97	17.27		80.0	
		Z	3.79	67.69	17.16		80.0	
10494-AAB	LTE-TDD (SC-FDMA, 50% RB, 20 MHz, QPSK, UL Subframe=2,3,4,7,8,9)	X	3.52	70.87	18.10	2.23	80.0	± 9.6 %
		Y	3.84	72.64	19.08		80.0	
		Z	3.98	72.03	18.67		80.0	
10495-AAB	LTE-TDD (SC-FDMA, 50% RB, 20 MHz, 16-QAM, UL Subframe=2,3,4,7,8,9)	X	3.45	67.59	16.97	2.23	80.0	± 9.6 %
		Y	3.58	68.42	17.54		80.0	
		Z	3.75	68.20	17.40		80.0	
10496-AAB	LTE-TDD (SC-FDMA, 50% RB, 20 MHz, 64-QAM, UL Subframe=2,3,4,7,8,9)	X	3.54	67.39	16.91	2.23	80.0	± 9.6 %
		Y	3.65	68.15	17.44		80.0	
		Z	3.83	67.94	17.32		80.0	
10497-AAA	LTE-TDD (SC-FDMA, 100% RB, 1.4 MHz, QPSK, UL Subframe=2,3,4,7,8,9)	X	1.43	63.58	11.40	2.23	80.0	± 9.6 %
		Y	1.80	66.67	13.09		80.0	
		Z	2.27	68.74	14.99		80.0	
10498-AAA	LTE-TDD (SC-FDMA, 100% RB, 1.4 MHz, 16-QAM, UL Subframe=2,3,4,7,8,9)	X	1.24	60.00	8.33	2.23	80.0	± 9.6 %
		Y	1.23	60.00	8.51		80.0	
		Z	1.81	63.14	11.27		80.0	
10499-AAA	LTE-TDD (SC-FDMA, 100% RB, 1.4 MHz, 64-QAM, UL Subframe=2,3,4,7,8,9)	X	1.26	60.00	8.18	2.23	80.0	± 9.6 %
		Y	1.24	60.00	8.34		80.0	
		Z	1.76	62.56	10.83		80.0	
10500-AAA	LTE-TDD (SC-FDMA, 100% RB, 3 MHz, QPSK, UL Subframe=2,3,4,7,8,9)	X	2.78	70.93	17.56	2.23	80.0	± 9.6 %
		Y	3.23	73.75	19.01		80.0	
		Z	3.21	72.13	18.47		80.0	
10501-AAA	LTE-TDD (SC-FDMA, 100% RB, 3 MHz, 16-QAM, UL Subframe=2,3,4,7,8,9)	X	2.86	67.97	15.75	2.23	80.0	± 9.6 %
		Y	3.13	69.65	16.71		80.0	
		Z	3.25	69.01	16.80		80.0	
10502-AAA	LTE-TDD (SC-FDMA, 100% RB, 3 MHz, 64-QAM, UL Subframe=2,3,4,7,8,9)	X	2.90	67.83	15.61	2.23	80.0	± 9.6 %
		Y	3.18	69.45	16.55		80.0	
		Z	3.31	68.90	16.69		80.0	
10503-AAB	LTE-TDD (SC-FDMA, 100% RB, 5 MHz, QPSK, UL Subframe=2,3,4,7,8,9)	X	2.96	70.56	17.92	2.23	80.0	± 9.6 %
		Y	3.29	72.71	19.10		80.0	
		Z	3.38	71.68	18.59		80.0	
10504-AAB	LTE-TDD (SC-FDMA, 100% RB, 5 MHz, 16-QAM, UL Subframe=2,3,4,7,8,9)	X	3.05	67.84	16.62	2.23	80.0	± 9.6 %
		Y	3.22	69.00	17.36		80.0	
		Z	3.35	68.44	17.21		80.0	
10505-AAB	LTE-TDD (SC-FDMA, 100% RB, 5 MHz, 64-QAM, UL Subframe=2,3,4,7,8,9)	X	3.14	67.73	16.57	2.23	80.0	± 9.6 %
		Y	3.31	68.81	17.27		80.0	
		Z	3.45	68.28	17.16		80.0	
10506-AAB	LTE-TDD (SC-FDMA, 100% RB, 10 MHz, QPSK, UL Subframe=2,3,4,7,8,9)	X	3.49	70.73	18.03	2.23	80.0	± 9.6 %
		Y	3.81	72.49	19.00		80.0	
		Z	3.95	71.88	18.59		80.0	
10507-AAB	LTE-TDD (SC-FDMA, 100% RB, 10 MHz, 16-QAM, UL Subframe=2,3,4,7,8,9)	X	3.44	67.53	16.93	2.23	80.0	± 9.6 %
		Y	3.56	68.36	17.50		80.0	
		Z	3.73	68.13	17.36		80.0	

10508-AAB	LTE-TDD (SC-FDMA, 100% RB, 10 MHz, 64-QAM, UL Subframe=2,3,4,7,8,9)	X	3.53	67.32	16.87	2.23	80.0	± 9.6 %
		Y	3.64	68.08	17.40		80.0	
		Z	3.82	67.87	17.27		80.0	
10509-AAB	LTE-TDD (SC-FDMA, 100% RB, 15 MHz, QPSK, UL Subframe=2,3,4,7,8,9)	X	3.90	69.82	17.65	2.23	80.0	± 9.6 %
		Y	4.14	71.06	18.38		80.0	
		Z	4.30	70.72	18.09		80.0	
10510-AAB	LTE-TDD (SC-FDMA, 100% RB, 15 MHz, 16-QAM, UL Subframe=2,3,4,7,8,9)	X	3.92	67.34	16.97	2.23	80.0	± 9.6 %
		Y	4.03	67.99	17.44		80.0	
		Z	4.22	67.93	17.34		80.0	
10511-AAB	LTE-TDD (SC-FDMA, 100% RB, 15 MHz, 64-QAM, UL Subframe=2,3,4,7,8,9)	X	3.99	67.15	16.93	2.23	80.0	± 9.6 %
		Y	4.09	67.75	17.36		80.0	
		Z	4.28	67.68	17.27		80.0	
10512-AAB	LTE-TDD (SC-FDMA, 100% RB, 20 MHz, QPSK, UL Subframe=2,3,4,7,8,9)	X	4.00	71.09	18.05	2.23	80.0	± 9.6 %
		Y	4.33	72.71	18.93		80.0	
		Z	4.49	72.31	18.60		80.0	
10513-AAB	LTE-TDD (SC-FDMA, 100% RB, 20 MHz, 16-QAM, UL Subframe=2,3,4,7,8,9)	X	3.80	67.50	17.05	2.23	80.0	± 9.6 %
		Y	3.92	68.21	17.54		80.0	
		Z	4.11	68.20	17.45		80.0	
10514-AAB	LTE-TDD (SC-FDMA, 100% RB, 20 MHz, 64-QAM, UL Subframe=2,3,4,7,8,9)	X	3.85	67.16	16.95	2.23	80.0	± 9.6 %
		Y	3.95	67.80	17.41		80.0	
		Z	4.13	67.78	17.32		80.0	
10515-AAA	IEEE 802.11b WiFi 2.4 GHz (DSSS, 2 Mbps, 99pc duty cycle)	X	0.99	63.41	14.95	0.00	150.0	± 9.6 %
		Y	1.00	63.71	15.22		150.0	
		Z	0.98	62.80	14.50		150.0	
10516-AAA	IEEE 802.11b WiFi 2.4 GHz (DSSS, 5.5 Mbps, 99pc duty cycle)	X	0.63	71.18	17.99	0.00	150.0	± 9.6 %
		Y	0.75	74.25	19.60		150.0	
		Z	0.56	68.07	16.15		150.0	
10517-AAA	IEEE 802.11b WiFi 2.4 GHz (DSSS, 11 Mbps, 99pc duty cycle)	X	0.84	65.39	15.66	0.00	150.0	± 9.6 %
		Y	0.87	66.03	16.14		150.0	
		Z	0.82	64.43	14.97		150.0	
10518-AAA	IEEE 802.11a/h WiFi 5 GHz (OFDM, 9 Mbps, 99pc duty cycle)	X	4.47	66.84	16.30	0.00	150.0	± 9.6 %
		Y	4.48	66.90	16.36		150.0	
		Z	4.58	66.60	16.20		150.0	
10519-AAA	IEEE 802.11a/h WiFi 5 GHz (OFDM, 12 Mbps, 99pc duty cycle)	X	4.63	67.03	16.39	0.00	150.0	± 9.6 %
		Y	4.64	67.09	16.46		150.0	
		Z	4.77	66.85	16.33		150.0	
10520-AAA	IEEE 802.11a/h WiFi 5 GHz (OFDM, 18 Mbps, 99pc duty cycle)	X	4.49	66.98	16.32	0.00	150.0	± 9.6 %
		Y	4.50	67.04	16.38		150.0	
		Z	4.62	66.81	16.25		150.0	
10521-AAA	IEEE 802.11a/h WiFi 5 GHz (OFDM, 24 Mbps, 99pc duty cycle)	X	4.42	66.97	16.30	0.00	150.0	± 9.6 %
		Y	4.43	67.03	16.37		150.0	
		Z	4.55	66.80	16.23		150.0	
10522-AAA	IEEE 802.11a/h WiFi 5 GHz (OFDM, 36 Mbps, 99pc duty cycle)	X	4.48	67.10	16.40	0.00	150.0	± 9.6 %
		Y	4.49	67.16	16.47		150.0	
		Z	4.61	66.88	16.31		150.0	

10523-AAA	IEEE 802.11a/h WiFi 5 GHz (OFDM, 48 Mbps, 99pc duty cycle)	X	4.38	67.02	16.28	0.00	150.0	± 9.6 %
		Y	4.40	67.08	16.35		150.0	
		Z	4.49	66.74	16.15		150.0	
10524-AAA	IEEE 802.11a/h WiFi 5 GHz (OFDM, 54 Mbps, 99pc duty cycle)	X	4.42	67.02	16.37	0.00	150.0	± 9.6 %
		Y	4.44	67.08	16.44		150.0	
		Z	4.56	66.80	16.28		150.0	
10525-AAA	IEEE 802.11ac WiFi (20MHz, MCS0, 99pc duty cycle)	X	4.44	66.11	15.98	0.00	150.0	± 9.6 %
		Y	4.45	66.16	16.04		150.0	
		Z	4.54	65.84	15.87		150.0	
10526-AAA	IEEE 802.11ac WiFi (20MHz, MCS1, 99pc duty cycle)	X	4.58	66.42	16.11	0.00	150.0	± 9.6 %
		Y	4.59	66.48	16.17		150.0	
		Z	4.71	66.22	16.01		150.0	
10527-AAA	IEEE 802.11ac WiFi (20MHz, MCS2, 99pc duty cycle)	X	4.51	66.39	16.05	0.00	150.0	± 9.6 %
		Y	4.52	66.45	16.12		150.0	
		Z	4.63	66.17	15.95		150.0	
10528-AAA	IEEE 802.11ac WiFi (20MHz, MCS3, 99pc duty cycle)	X	4.52	66.40	16.08	0.00	150.0	± 9.6 %
		Y	4.54	66.46	16.15		150.0	
		Z	4.65	66.19	15.99		150.0	
10529-AAA	IEEE 802.11ac WiFi (20MHz, MCS4, 99pc duty cycle)	X	4.52	66.40	16.08	0.00	150.0	± 9.6 %
		Y	4.54	66.46	16.15		150.0	
		Z	4.65	66.19	15.99		150.0	
10531-AAA	IEEE 802.11ac WiFi (20MHz, MCS6, 99pc duty cycle)	X	4.50	66.46	16.08	0.00	150.0	± 9.6 %
		Y	4.51	66.53	16.14		150.0	
		Z	4.64	66.30	16.00		150.0	
10532-AAA	IEEE 802.11ac WiFi (20MHz, MCS7, 99pc duty cycle)	X	4.37	66.32	16.01	0.00	150.0	± 9.6 %
		Y	4.39	66.39	16.08		150.0	
		Z	4.50	66.15	15.93		150.0	
10533-AAA	IEEE 802.11ac WiFi (20MHz, MCS8, 99pc duty cycle)	X	4.53	66.48	16.08	0.00	150.0	± 9.6 %
		Y	4.54	66.54	16.15		150.0	
		Z	4.66	66.23	15.97		150.0	
10534-AAA	IEEE 802.11ac WiFi (40MHz, MCS0, 99pc duty cycle)	X	5.07	66.45	16.14	0.00	150.0	± 9.6 %
		Y	5.09	66.50	16.19		150.0	
		Z	5.19	66.33	16.06		150.0	
10535-AAA	IEEE 802.11ac WiFi (40MHz, MCS1, 99pc duty cycle)	X	5.13	66.62	16.22	0.00	150.0	± 9.6 %
		Y	5.14	66.67	16.27		150.0	
		Z	5.25	66.51	16.14		150.0	
10536-AAA	IEEE 802.11ac WiFi (40MHz, MCS2, 99pc duty cycle)	X	5.01	66.59	16.19	0.00	150.0	± 9.6 %
		Y	5.03	66.64	16.24		150.0	
		Z	5.12	66.45	16.09		150.0	
10537-AAA	IEEE 802.11ac WiFi (40MHz, MCS3, 99pc duty cycle)	X	5.07	66.55	16.17	0.00	150.0	± 9.6 %
		Y	5.08	66.59	16.22		150.0	
		Z	5.18	66.42	16.08		150.0	
10538-AAA	IEEE 802.11ac WiFi (40MHz, MCS4, 99pc duty cycle)	X	5.14	66.54	16.20	0.00	150.0	± 9.6 %
		Y	5.15	66.59	16.25		150.0	
		Z	5.27	66.46	16.14		150.0	
10540-AAA	IEEE 802.11ac WiFi (40MHz, MCS6, 99pc duty cycle)	X	5.07	66.52	16.21	0.00	150.0	± 9.6 %
		Y	5.08	66.57	16.26		150.0	
		Z	5.20	66.47	16.16		150.0	

10541-AAA	IIEEE 802.11ac WiFi (40MHz, MCS7, 99pc duty cycle)	X	5.05	66.41	16.14	0.00	150.0	± 9.6 %
		Y	5.06	66.46	16.20		150.0	
		Z	5.17	66.33	16.08		150.0	
10542-AAA	IIEEE 802.11ac WiFi (40MHz, MCS8, 99pc duty cycle)	X	5.21	66.51	16.21	0.00	150.0	± 9.6 %
		Y	5.22	66.55	16.26		150.0	
		Z	5.33	66.41	16.13		150.0	
10543-AAA	IIEEE 802.11ac WiFi (40MHz, MCS9, 99pc duty cycle)	X	5.27	66.52	16.24	0.00	150.0	± 9.6 %
		Y	5.28	66.56	16.29		150.0	
		Z	5.41	66.45	16.18		150.0	
10544-AAA	IIEEE 802.11ac WiFi (80MHz, MCS0, 99pc duty cycle)	X	5.40	66.53	16.13	0.00	150.0	± 9.6 %
		Y	5.42	66.58	16.18		150.0	
		Z	5.49	66.45	16.06		150.0	
10545-AAA	IIEEE 802.11ac WiFi (80MHz, MCS1, 99pc duty cycle)	X	5.59	66.98	16.30	0.00	150.0	± 9.6 %
		Y	5.60	67.03	16.36		150.0	
		Z	5.69	66.88	16.22		150.0	
10546-AAA	IIEEE 802.11ac WiFi (80MHz, MCS2, 99pc duty cycle)	X	5.45	66.68	16.17	0.00	150.0	± 9.6 %
		Y	5.46	66.73	16.22		150.0	
		Z	5.56	66.67	16.13		150.0	
10547-AAA	IIEEE 802.11ac WiFi (80MHz, MCS3, 99pc duty cycle)	X	5.52	66.76	16.20	0.00	150.0	± 9.6 %
		Y	5.53	66.80	16.25		150.0	
		Z	5.63	66.71	16.14		150.0	
10548-AAA	IIEEE 802.11ac WiFi (80MHz, MCS4, 99pc duty cycle)	X	5.72	67.56	16.57	0.00	150.0	± 9.6 %
		Y	5.74	67.62	16.64		150.0	
		Z	5.92	67.73	16.62		150.0	
10550-AAA	IIEEE 802.11ac WiFi (80MHz, MCS6, 99pc duty cycle)	X	5.50	66.81	16.24	0.00	150.0	± 9.6 %
		Y	5.51	66.85	16.30		150.0	
		Z	5.59	66.68	16.14		150.0	
10551-AAA	IIEEE 802.11ac WiFi (80MHz, MCS7, 99pc duty cycle)	X	5.47	66.72	16.16	0.00	150.0	± 9.6 %
		Y	5.48	66.77	16.22		150.0	
		Z	5.59	66.72	16.13		150.0	
10552-AAA	IIEEE 802.11ac WiFi (80MHz, MCS8, 99pc duty cycle)	X	5.41	66.62	16.12	0.00	150.0	± 9.6 %
		Y	5.42	66.66	16.16		150.0	
		Z	5.50	66.51	16.03		150.0	
10553-AAA	IIEEE 802.11ac WiFi (80MHz, MCS9, 99pc duty cycle)	X	5.48	66.60	16.14	0.00	150.0	± 9.6 %
		Y	5.49	66.65	16.19		150.0	
		Z	5.59	66.56	16.08		150.0	
10554-AAA	IIEEE 1602.11ac WiFi (160MHz, MCS0, 99pc duty cycle)	X	5.82	66.88	16.21	0.00	150.0	± 9.6 %
		Y	5.83	66.92	16.26		150.0	
		Z	5.90	66.82	16.15		150.0	
10555-AAA	IIEEE 1602.11ac WiFi (160MHz, MCS1, 99pc duty cycle)	X	5.94	67.15	16.33	0.00	150.0	± 9.6 %
		Y	5.95	67.20	16.38		150.0	
		Z	6.03	67.13	16.28		150.0	
10556-AAA	IIEEE 1602.11ac WiFi (160MHz, MCS2, 99pc duty cycle)	X	5.96	67.23	16.36	0.00	150.0	± 9.6 %
		Y	5.98	67.27	16.41		150.0	
		Z	6.05	67.17	16.30		150.0	
10557-AAA	IIEEE 1602.11ac WiFi (160MHz, MCS3, 99pc duty cycle)	X	5.92	67.10	16.31	0.00	150.0	± 9.6 %
		Y	5.93	67.14	16.36		150.0	
		Z	6.02	67.08	16.27		150.0	

10558-AAA	IEEE 1602.11ac WiFi (160MHz, MCS4, 99pc duty cycle)	X	5.96	67.24	16.39	0.00	150.0	± 9.6 %
		Y	5.97	67.29	16.45		150.0	
		Z	6.07	67.25	16.37		150.0	
10560-AAA	IEEE 1602.11ac WiFi (160MHz, MCS6, 99pc duty cycle)	X	5.95	67.10	16.36	0.00	150.0	± 9.6 %
		Y	5.97	67.14	16.41		150.0	
		Z	6.06	67.09	16.33		150.0	
10561-AAA	IEEE 1602.11ac WiFi (160MHz, MCS7, 99pc duty cycle)	X	5.89	67.09	16.39	0.00	150.0	± 9.6 %
		Y	5.90	67.14	16.45		150.0	
		Z	5.99	67.06	16.35		150.0	
10562-AAA	IEEE 1602.11ac WiFi (160MHz, MCS8, 99pc duty cycle)	X	5.97	67.34	16.52	0.00	150.0	± 9.6 %
		Y	5.98	67.39	16.57		150.0	
		Z	6.12	67.47	16.55		150.0	
10563-AAA	IEEE 1602.11ac WiFi (160MHz, MCS9, 99pc duty cycle)	X	6.05	67.24	16.43	0.00	150.0	± 9.6 %
		Y	6.06	67.29	16.49		150.0	
		Z	6.41	67.91	16.73		150.0	
10564-AAA	IEEE 802.11g WiFi 2.4 GHz (DSSS-OFDM, 9 Mbps, 99pc duty cycle)	X	4.78	66.85	16.41	0.46	150.0	± 9.6 %
		Y	4.80	66.93	16.49		150.0	
		Z	4.91	66.67	16.35		150.0	
10565-AAA	IEEE 802.11g WiFi 2.4 GHz (DSSS-OFDM, 12 Mbps, 99pc duty cycle)	X	4.99	67.29	16.74	0.46	150.0	± 9.6 %
		Y	5.01	67.35	16.80		150.0	
		Z	5.14	67.15	16.69		150.0	
10566-AAA	IEEE 802.11g WiFi 2.4 GHz (DSSS-OFDM, 18 Mbps, 99pc duty cycle)	X	4.83	67.11	16.54	0.46	150.0	± 9.6 %
		Y	4.84	67.18	16.62		150.0	
		Z	4.98	66.99	16.50		150.0	
10567-AAA	IEEE 802.11g WiFi 2.4 GHz (DSSS-OFDM, 24 Mbps, 99pc duty cycle)	X	4.87	67.55	16.94	0.46	150.0	± 9.6 %
		Y	4.87	67.57	16.98		150.0	
		Z	5.01	67.40	16.87		150.0	
10568-AAA	IEEE 802.11g WiFi 2.4 GHz (DSSS-OFDM, 36 Mbps, 99pc duty cycle)	X	4.73	66.85	16.28	0.46	150.0	± 9.6 %
		Y	4.75	66.97	16.39		150.0	
		Z	4.88	66.73	16.25		150.0	
10569-AAA	IEEE 802.11g WiFi 2.4 GHz (DSSS-OFDM, 48 Mbps, 99pc duty cycle)	X	4.84	67.72	17.05	0.46	150.0	± 9.6 %
		Y	4.85	67.73	17.08		150.0	
		Z	4.96	67.48	16.93		150.0	
10570-AAA	IEEE 802.11g WiFi 2.4 GHz (DSSS-OFDM, 54 Mbps, 99pc duty cycle)	X	4.86	67.53	16.95	0.46	150.0	± 9.6 %
		Y	4.87	67.55	16.99		150.0	
		Z	5.00	67.32	16.86		150.0	
10571-AAA	IEEE 802.11b WiFi 2.4 GHz (DSSS, 1 Mbps, 90pc duty cycle)	X	1.13	63.98	15.42	0.46	130.0	± 9.6 %
		Y	1.15	64.46	15.85		130.0	
		Z	1.15	63.75	15.28		130.0	
10572-AAA	IEEE 802.11b WiFi 2.4 GHz (DSSS, 2 Mbps, 90pc duty cycle)	X	1.14	64.53	15.78	0.46	130.0	± 9.6 %
		Y	1.16	65.03	16.22		130.0	
		Z	1.16	64.27	15.61		130.0	
10573-AAA	IEEE 802.11b WiFi 2.4 GHz (DSSS, 5.5 Mbps, 90pc duty cycle)	X	1.37	80.51	21.92	0.46	130.0	± 9.6 %
		Y	2.18	89.24	25.44		130.0	
		Z	1.24	77.68	20.60		130.0	
10574-AAA	IEEE 802.11b WiFi 2.4 GHz (DSSS, 11 Mbps, 90pc duty cycle)	X	1.21	70.03	18.74	0.46	130.0	± 9.6 %
		Y	1.26	70.93	19.36		130.0	
		Z	1.21	69.23	18.24		130.0	

10575-AAA	IEEE 802.11g WiFi 2.4 GHz (DSSS-OFDM, 6 Mbps, 90pc duty cycle)	X	4.55	66.59	16.41	0.46	130.0	± 9.6 %
		Y	4.57	66.69	16.52		130.0	
		Z	4.69	66.45	16.40		130.0	
10576-AAA	IEEE 802.11g WiFi 2.4 GHz (DSSS-OFDM, 9 Mbps, 90pc duty cycle)	X	4.58	66.78	16.50	0.46	130.0	± 9.6 %
		Y	4.60	66.87	16.60		130.0	
		Z	4.71	66.62	16.47		130.0	
10577-AAA	IEEE 802.11g WiFi 2.4 GHz (DSSS-OFDM, 12 Mbps, 90pc duty cycle)	X	4.76	67.04	16.65	0.46	130.0	± 9.6 %
		Y	4.78	67.12	16.75		130.0	
		Z	4.92	66.93	16.65		130.0	
10578-AAA	IEEE 802.11g WiFi 2.4 GHz (DSSS-OFDM, 18 Mbps, 90pc duty cycle)	X	4.67	67.21	16.78	0.46	130.0	± 9.6 %
		Y	4.68	67.27	16.85		130.0	
		Z	4.82	67.09	16.76		130.0	
10579-AAA	IEEE 802.11g WiFi 2.4 GHz (DSSS-OFDM, 24 Mbps, 90pc duty cycle)	X	4.41	66.37	16.00	0.46	130.0	± 9.6 %
		Y	4.44	66.52	16.15		130.0	
		Z	4.58	66.34	16.04		130.0	
10580-AAA	IEEE 802.11g WiFi 2.4 GHz (DSSS-OFDM, 36 Mbps, 90pc duty cycle)	X	4.45	66.43	16.02	0.46	130.0	± 9.6 %
		Y	4.49	66.59	16.18		130.0	
		Z	4.62	66.36	16.05		130.0	
10581-AAA	IEEE 802.11g WiFi 2.4 GHz (DSSS-OFDM, 48 Mbps, 90pc duty cycle)	X	4.57	67.26	16.72	0.46	130.0	± 9.6 %
		Y	4.58	67.33	16.82		130.0	
		Z	4.71	67.12	16.69		130.0	
10582-AAA	IEEE 802.11g WiFi 2.4 GHz (DSSS-OFDM, 54 Mbps, 90pc duty cycle)	X	4.34	66.11	15.76	0.46	130.0	± 9.6 %
		Y	4.38	66.30	15.94		130.0	
		Z	4.52	66.09	15.82		130.0	
10583-AAA	IEEE 802.11a/h WiFi 5 GHz (OFDM, 6 Mbps, 90pc duty cycle)	X	4.55	66.59	16.41	0.46	130.0	± 9.6 %
		Y	4.57	66.69	16.52		130.0	
		Z	4.69	66.45	16.40		130.0	
10584-AAA	IEEE 802.11a/h WiFi 5 GHz (OFDM, 9 Mbps, 90pc duty cycle)	X	4.58	66.78	16.50	0.46	130.0	± 9.6 %
		Y	4.60	66.87	16.60		130.0	
		Z	4.71	66.62	16.47		130.0	
10585-AAA	IEEE 802.11a/h WiFi 5 GHz (OFDM, 12 Mbps, 90pc duty cycle)	X	4.76	67.04	16.65	0.46	130.0	± 9.6 %
		Y	4.78	67.12	16.75		130.0	
		Z	4.92	66.93	16.65		130.0	
10586-AAA	IEEE 802.11a/h WiFi 5 GHz (OFDM, 18 Mbps, 90pc duty cycle)	X	4.67	67.21	16.78	0.46	130.0	± 9.6 %
		Y	4.68	67.27	16.85		130.0	
		Z	4.82	67.09	16.76		130.0	
10587-AAA	IEEE 802.11a/h WiFi 5 GHz (OFDM, 24 Mbps, 90pc duty cycle)	X	4.41	66.37	16.00	0.46	130.0	± 9.6 %
		Y	4.44	66.52	16.15		130.0	
		Z	4.58	66.34	16.04		130.0	
10588-AAA	IEEE 802.11a/h WiFi 5 GHz (OFDM, 36 Mbps, 90pc duty cycle)	X	4.45	66.43	16.02	0.46	130.0	± 9.6 %
		Y	4.49	66.59	16.18		130.0	
		Z	4.62	66.36	16.05		130.0	
10589-AAA	IEEE 802.11a/h WiFi 5 GHz (OFDM, 48 Mbps, 90pc duty cycle)	X	4.57	67.26	16.72	0.46	130.0	± 9.6 %
		Y	4.58	67.33	16.82		130.0	
		Z	4.71	67.12	16.69		130.0	
10590-AAA	IEEE 802.11a/h WiFi 5 GHz (OFDM, 54 Mbps, 90pc duty cycle)	X	4.34	66.11	15.76	0.46	130.0	± 9.6 %
		Y	4.38	66.30	15.94		130.0	
		Z	4.52	66.09	15.82		130.0	

10591-AAA	IEEE 802.11n (HT Mixed, 20MHz, MCS0, 90pc duty cycle)	X	4.71	66.67	16.53	0.46	130.0	± 9.6 %
		Y	4.73	66.75	16.62		130.0	
		Z	4.84	66.53	16.51		130.0	
10592-AAA	IEEE 802.11n (HT Mixed, 20MHz, MCS1, 90pc duty cycle)	X	4.84	66.99	16.66	0.46	130.0	± 9.6 %
		Y	4.86	67.07	16.75		130.0	
		Z	5.00	66.87	16.64		130.0	
10593-AAA	IEEE 802.11n (HT Mixed, 20MHz, MCS2, 90pc duty cycle)	X	4.76	66.86	16.52	0.46	130.0	± 9.6 %
		Y	4.78	66.96	16.62		130.0	
		Z	4.92	66.77	16.52		130.0	
10594-AAA	IEEE 802.11n (HT Mixed, 20MHz, MCS3, 90pc duty cycle)	X	4.82	67.05	16.69	0.46	130.0	± 9.6 %
		Y	4.84	67.13	16.78		130.0	
		Z	4.97	66.94	16.68		130.0	
10595-AAA	IEEE 802.11n (HT Mixed, 20MHz, MCS4, 90pc duty cycle)	X	4.78	67.01	16.59	0.46	130.0	± 9.6 %
		Y	4.80	67.10	16.69		130.0	
		Z	4.94	66.89	16.57		130.0	
10596-AAA	IEEE 802.11n (HT Mixed, 20MHz, MCS5, 90pc duty cycle)	X	4.71	66.98	16.58	0.46	130.0	± 9.6 %
		Y	4.73	67.08	16.69		130.0	
		Z	4.87	66.88	16.57		130.0	
10597-AAA	IEEE 802.11n (HT Mixed, 20MHz, MCS6, 90pc duty cycle)	X	4.66	66.85	16.44	0.46	130.0	± 9.6 %
		Y	4.69	66.96	16.56		130.0	
		Z	4.82	66.78	16.45		130.0	
10598-AAA	IEEE 802.11n (HT Mixed, 20MHz, MCS7, 90pc duty cycle)	X	4.65	67.11	16.73	0.46	130.0	± 9.6 %
		Y	4.67	67.18	16.81		130.0	
		Z	4.81	67.03	16.73		130.0	
10599-AAA	IEEE 802.11n (HT Mixed, 40MHz, MCS0, 90pc duty cycle)	X	5.39	67.16	16.75	0.46	130.0	± 9.6 %
		Y	5.40	67.23	16.84		130.0	
		Z	5.52	67.11	16.73		130.0	
10600-AAA	IEEE 802.11n (HT Mixed, 40MHz, MCS1, 90pc duty cycle)	X	5.51	67.57	16.93	0.46	130.0	± 9.6 %
		Y	5.53	67.67	17.03		130.0	
		Z	5.67	67.58	16.94		130.0	
10601-AAA	IEEE 802.11n (HT Mixed, 40MHz, MCS2, 90pc duty cycle)	X	5.40	67.32	16.82	0.46	130.0	± 9.6 %
		Y	5.42	67.41	16.92		130.0	
		Z	5.55	67.30	16.82		130.0	
10602-AAA	IEEE 802.11n (HT Mixed, 40MHz, MCS3, 90pc duty cycle)	X	5.53	67.48	16.82	0.46	130.0	± 9.6 %
		Y	5.55	67.58	16.92		130.0	
		Z	5.64	67.31	16.73		130.0	
10603-AAA	IEEE 802.11n (HT Mixed, 40MHz, MCS4, 90pc duty cycle)	X	5.60	67.77	17.10	0.46	130.0	± 9.6 %
		Y	5.62	67.84	17.19		130.0	
		Z	5.72	67.63	17.03		130.0	
10604-AAA	IEEE 802.11n (HT Mixed, 40MHz, MCS5, 90pc duty cycle)	X	5.48	67.44	16.92	0.46	130.0	± 9.6 %
		Y	5.50	67.51	17.01		130.0	
		Z	5.52	67.07	16.74		130.0	
10605-AAA	IEEE 802.11n (HT Mixed, 40MHz, MCS6, 90pc duty cycle)	X	5.51	67.48	16.93	0.46	130.0	± 9.6 %
		Y	5.53	67.59	17.04		130.0	
		Z	5.64	67.42	16.91		130.0	
10606-AAA	IEEE 802.11n (HT Mixed, 40MHz, MCS7, 90pc duty cycle)	X	5.24	66.77	16.43	0.46	130.0	± 9.6 %
		Y	5.27	66.88	16.54		130.0	
		Z	5.39	66.79	16.45		130.0	

10607-AAA	IEEE 802.11ac WiFi (20MHz, MCS0, 90pc duty cycle)	X	4.56	66.02	16.17	0.46	130.0	± 9.6 %
		Y	4.58	66.11	16.27		130.0	
		Z	4.68	65.84	16.13		130.0	
10608-AAA	IEEE 802.11ac WiFi (20MHz, MCS1, 90pc duty cycle)	X	4.71	66.38	16.33	0.46	130.0	± 9.6 %
		Y	4.74	66.48	16.43		130.0	
		Z	4.87	66.25	16.30		130.0	
10609-AAA	IEEE 802.11ac WiFi (20MHz, MCS2, 90pc duty cycle)	X	4.60	66.21	16.15	0.46	130.0	± 9.6 %
		Y	4.63	66.32	16.26		130.0	
		Z	4.75	66.09	16.13		130.0	
10610-AAA	IEEE 802.11ac WiFi (20MHz, MCS3, 90pc duty cycle)	X	4.66	66.38	16.32	0.46	130.0	± 9.6 %
		Y	4.68	66.48	16.42		130.0	
		Z	4.81	66.25	16.30		130.0	
10611-AAA	IEEE 802.11ac WiFi (20MHz, MCS4, 90pc duty cycle)	X	4.57	66.17	16.16	0.46	130.0	± 9.6 %
		Y	4.59	66.28	16.27		130.0	
		Z	4.72	66.06	16.14		130.0	
10612-AAA	IEEE 802.11ac WiFi (20MHz, MCS5, 90pc duty cycle)	X	4.57	66.31	16.20	0.46	130.0	± 9.6 %
		Y	4.59	66.44	16.32		130.0	
		Z	4.73	66.20	16.18		130.0	
10613-AAA	IEEE 802.11ac WiFi (20MHz, MCS6, 90pc duty cycle)	X	4.56	66.14	16.05	0.46	130.0	± 9.6 %
		Y	4.59	66.27	16.18		130.0	
		Z	4.73	66.09	16.06		130.0	
10614-AAA	IEEE 802.11ac WiFi (20MHz, MCS7, 90pc duty cycle)	X	4.53	66.39	16.32	0.46	130.0	± 9.6 %
		Y	4.55	66.47	16.42		130.0	
		Z	4.68	66.29	16.31		130.0	
10615-AAA	IEEE 802.11ac WiFi (20MHz, MCS8, 90pc duty cycle)	X	4.56	65.98	15.91	0.46	130.0	± 9.6 %
		Y	4.59	66.13	16.05		130.0	
		Z	4.72	65.87	15.91		130.0	
10616-AAA	IEEE 802.11ac WiFi (40MHz, MCS0, 90pc duty cycle)	X	5.20	66.41	16.36	0.46	130.0	± 9.6 %
		Y	5.22	66.48	16.45		130.0	
		Z	5.34	66.37	16.34		130.0	
10617-AAA	IEEE 802.11ac WiFi (40MHz, MCS1, 90pc duty cycle)	X	5.27	66.60	16.43	0.46	130.0	± 9.6 %
		Y	5.29	66.69	16.53		130.0	
		Z	5.41	66.54	16.40		130.0	
10618-AAA	IEEE 802.11ac WiFi (40MHz, MCS2, 90pc duty cycle)	X	5.17	66.64	16.47	0.46	130.0	± 9.6 %
		Y	5.19	66.72	16.55		130.0	
		Z	5.29	66.54	16.42		130.0	
10619-AAA	IEEE 802.11ac WiFi (40MHz, MCS3, 90pc duty cycle)	X	5.17	66.40	16.28	0.46	130.0	± 9.6 %
		Y	5.19	66.49	16.38		130.0	
		Z	5.31	66.37	16.27		130.0	
10620-AAA	IEEE 802.11ac WiFi (40MHz, MCS4, 90pc duty cycle)	X	5.25	66.42	16.34	0.46	130.0	± 9.6 %
		Y	5.27	66.52	16.44		130.0	
		Z	5.40	66.41	16.34		130.0	
10621-AAA	IEEE 802.11ac WiFi (40MHz, MCS5, 90pc duty cycle)	X	5.27	66.59	16.55	0.46	130.0	± 9.6 %
		Y	5.28	66.65	16.62		130.0	
		Z	5.40	66.53	16.52		130.0	
10622-AAA	IEEE 802.11ac WiFi (40MHz, MCS6, 90pc duty cycle)	X	5.27	66.70	16.60	0.46	130.0	± 9.6 %
		Y	5.28	66.78	16.68		130.0	
		Z	5.41	66.70	16.60		130.0	

10623-AAA	IEEE 802.11ac WiFi (40MHz, MCS7, 90pc duty cycle)	X	5.14	66.21	16.21	0.46	130.0	± 9.6 %
		Y	5.16	66.31	16.32		130.0	
		Z	5.28	66.20	16.22		130.0	
10624-AAA	IEEE 802.11ac WiFi (40MHz, MCS8, 90pc duty cycle)	X	5.34	66.45	16.40	0.46	130.0	± 9.6 %
		Y	5.36	66.54	16.49		130.0	
		Z	5.48	66.42	16.39		130.0	
10625-AAA	IEEE 802.11ac WiFi (40MHz, MCS9, 90pc duty cycle)	X	5.55	66.97	16.72	0.46	130.0	± 9.6 %
		Y	5.57	67.07	16.81		130.0	
		Z	5.88	67.48	16.97		130.0	
10626-AAA	IEEE 802.11ac WiFi (80MHz, MCS0, 90pc duty cycle)	X	5.53	66.46	16.32	0.46	130.0	± 9.6 %
		Y	5.54	66.54	16.40		130.0	
		Z	5.63	66.43	16.30		130.0	
10627-AAA	IEEE 802.11ac WiFi (80MHz, MCS1, 90pc duty cycle)	X	5.77	67.07	16.59	0.46	130.0	± 9.6 %
		Y	5.79	67.16	16.68		130.0	
		Z	5.88	67.02	16.56		130.0	
10628-AAA	IEEE 802.11ac WiFi (80MHz, MCS2, 90pc duty cycle)	X	5.53	66.46	16.22	0.46	130.0	± 9.6 %
		Y	5.55	66.56	16.32		130.0	
		Z	5.67	66.54	16.25		130.0	
10629-AAA	IEEE 802.11ac WiFi (80MHz, MCS3, 90pc duty cycle)	X	5.62	66.57	16.27	0.46	130.0	± 9.6 %
		Y	5.64	66.67	16.37		130.0	
		Z	5.76	66.64	16.29		130.0	
10630-AAA	IEEE 802.11ac WiFi (80MHz, MCS4, 90pc duty cycle)	X	5.96	67.80	16.88	0.46	130.0	± 9.6 %
		Y	5.98	67.92	17.00		130.0	
		Z	6.25	68.26	17.09		130.0	
10631-AAA	IEEE 802.11ac WiFi (80MHz, MCS5, 90pc duty cycle)	X	5.89	67.74	17.06	0.46	130.0	± 9.6 %
		Y	5.91	67.78	17.11		130.0	
		Z	6.11	67.97	17.16		130.0	
10632-AAA	IEEE 802.11ac WiFi (80MHz, MCS6, 90pc duty cycle)	X	5.75	67.20	16.81	0.46	130.0	± 9.6 %
		Y	5.76	67.24	16.86		130.0	
		Z	5.85	67.08	16.73		130.0	
10633-AAA	IEEE 802.11ac WiFi (80MHz, MCS7, 90pc duty cycle)	X	5.60	66.69	16.37	0.46	130.0	± 9.6 %
		Y	5.62	66.77	16.45		130.0	
		Z	5.73	66.69	16.36		130.0	
10634-AAA	IEEE 802.11ac WiFi (80MHz, MCS8, 90pc duty cycle)	X	5.58	66.71	16.44	0.46	130.0	± 9.6 %
		Y	5.60	66.78	16.51		130.0	
		Z	5.72	66.73	16.44		130.0	
10635-AAA	IEEE 802.11ac WiFi (80MHz, MCS9, 90pc duty cycle)	X	5.44	65.95	15.77	0.46	130.0	± 9.6 %
		Y	5.47	66.09	15.91		130.0	
		Z	5.60	66.05	15.82		130.0	
10636-AAA	IEEE 1602.11ac WiFi (160MHz, MCS0, 90pc duty cycle)	X	5.96	66.83	16.41	0.46	130.0	± 9.6 %
		Y	5.97	66.90	16.49		130.0	
		Z	6.05	66.82	16.40		130.0	
10637-AAA	IEEE 1602.11ac WiFi (160MHz, MCS1, 90pc duty cycle)	X	6.10	67.19	16.58	0.46	130.0	± 9.6 %
		Y	6.12	67.27	16.66		130.0	
		Z	6.21	67.21	16.58		130.0	
10638-AAA	IEEE 1602.11ac WiFi (160MHz, MCS2, 90pc duty cycle)	X	6.10	67.17	16.54	0.46	130.0	± 9.6 %
		Y	6.12	67.25	16.63		130.0	
		Z	6.21	67.17	16.54		130.0	

10639-AAA	IEEE 1602.11ac WiFi (160MHz, MCS3, 90pc duty cycle)	X	6.07	67.09	16.55	0.46	130.0	± 9.6 %
		Y	6.09	67.17	16.63		130.0	
		Z	6.19	67.14	16.56		130.0	
10640-AAA	IEEE 1602.11ac WiFi (160MHz, MCS4, 90pc duty cycle)	X	6.06	67.06	16.47	0.46	130.0	± 9.6 %
		Y	6.08	67.16	16.57		130.0	
		Z	6.19	67.15	16.51		130.0	
10641-AAA	IEEE 1602.11ac WiFi (160MHz, MCS5, 90pc duty cycle)	X	6.13	67.06	16.49	0.46	130.0	± 9.6 %
		Y	6.15	67.15	16.59		130.0	
		Z	6.23	67.02	16.46		130.0	
10642-AAA	IEEE 1602.11ac WiFi (160MHz, MCS6, 90pc duty cycle)	X	6.16	67.29	16.78	0.46	130.0	± 9.6 %
		Y	6.17	67.34	16.84		130.0	
		Z	6.28	67.31	16.78		130.0	
10643-AAA	IEEE 1602.11ac WiFi (160MHz, MCS7, 90pc duty cycle)	X	6.00	66.97	16.51	0.46	130.0	± 9.6 %
		Y	6.02	67.06	16.61		130.0	
		Z	6.11	66.97	16.50		130.0	
10644-AAA	IEEE 1602.11ac WiFi (160MHz, MCS8, 90pc duty cycle)	X	6.09	67.26	16.67	0.46	130.0	± 9.6 %
		Y	6.12	67.36	16.77		130.0	
		Z	6.29	67.52	16.80		130.0	
10645-AAA	IEEE 1602.11ac WiFi (160MHz, MCS9, 90pc duty cycle)	X	6.23	67.33	16.67	0.46	130.0	± 9.6 %
		Y	6.26	67.42	16.77		130.0	
		Z	6.72	68.38	17.18		130.0	
10646-AAC	LTE-TDD (SC-FDMA, 1 RB, 5 MHz, QPSK, UL Subframe=2,7)	X	7.97	91.85	31.39	9.30	60.0	± 9.6 %
		Y	11.74	104.28	36.86		60.0	
		Z	11.88	99.49	34.28		60.0	
10647-AAB	LTE-TDD (SC-FDMA, 1 RB, 20 MHz, QPSK, UL Subframe=2,7)	X	7.13	89.84	30.79	9.30	60.0	± 9.6 %
		Y	9.93	100.75	35.82		60.0	
		Z	10.62	97.47	33.72		60.0	
10648-AAA	CDMA2000 (1x Advanced)	X	0.64	63.39	10.24	0.00	150.0	± 9.6 %
		Y	0.67	63.88	10.62		150.0	
		Z	0.72	63.48	11.02		150.0	

^E Uncertainty is determined using the max. deviation from linear response applying rectangular distribution and is expressed for the square of the field value.



Accredited by the Swiss Accreditation Service (SAS)
The Swiss Accreditation Service is one of the signatories to the EA
Multilateral Agreement for the recognition of calibration certificates

Accreditation No.: **SCS 0108**

Client **PC Test**

Certificate No: **EX3-3914_Feb17/2**

CALIBRATION CERTIFICATE (Replacement of No: EX3-3914_Feb17)

Object **EX3DV4 - SN:3914**

Calibration procedure(s) **QA CAL-01.v9, QA CAL-12.v9, QA CAL-14.v4, QA CAL-23.v5,
QA CAL-25.v6
Calibration procedure for dosimetric E-field probes**

Calibration date: **February 13, 2017**

*BNV
10/30/2017*

This calibration certificate documents the traceability to national standards, which realize the physical units of measurements (SI).
The measurements and the uncertainties with confidence probability are given on the following pages and are part of the certificate.

All calibrations have been conducted in the closed laboratory facility: environment temperature (22 ± 3)°C and humidity < 70%.

Calibration Equipment used (M&TE critical for calibration)

Primary Standards	ID	Cal Date (Certificate No.)	Scheduled Calibration
Power meter NRP	SN: 104778	06-Apr-16 (No. 217-02288/02289)	Apr-17
Power sensor NRP-Z91	SN: 103244	06-Apr-16 (No. 217-02288)	Apr-17
Power sensor NRP-Z91	SN: 103245	06-Apr-16 (No. 217-02289)	Apr-17
Reference 20 dB Attenuator	SN: S5277 (20x)	05-Apr-16 (No. 217-02293)	Apr-17
Reference Probe ES3DV2	SN: 3013	31-Dec-16 (No. ES3-3013_Dec16)	Dec-17
DAE4	SN: 660	7-Dec-16 (No. DAE4-660_Dec16)	Dec-17
Secondary Standards	ID	Check Date (in house)	Scheduled Check
Power meter E4419B	SN: GB41293874	06-Apr-16 (in house check Jun-16)	In house check: Jun-18
Power sensor E4412A	SN: MY41498087	06-Apr-16 (in house check Jun-16)	In house check: Jun-18
Power sensor E4412A	SN: 000110210	06-Apr-16 (in house check Jun-16)	In house check: Jun-18
RF generator HP 8648C	SN: US3642U01700	04-Aug-99 (in house check Jun-16)	In house check: Jun-18
Network Analyzer HP 8753E	SN: US37390585	18-Oct-01 (in house check Oct-16)	In house check: Oct-17

Calibrated by:	Name Jeton Kastrati	Function Laboratory Technician	Signature
Approved by:	Name Katja Pokovic	Function Technical Manager	Signature

Issued: October 19, 2017

This calibration certificate shall not be reproduced except in full without written approval of the laboratory.



Accredited by the Swiss Accreditation Service (SAS)

Accreditation No.: **SCS 0108**

The Swiss Accreditation Service is one of the signatories to the EA
Multilateral Agreement for the recognition of calibration certificates

Glossary:

TSL	tissue simulating liquid
NORM _{x,y,z}	sensitivity in free space
ConvF	sensitivity in TSL / NORM _{x,y,z}
DCP	diode compression point
CF	crest factor (1/duty_cycle) of the RF signal
A, B, C, D	modulation dependent linearization parameters
Polarization φ	φ rotation around probe axis
Polarization ϑ	ϑ rotation around an axis that is in the plane normal to probe axis (at measurement center), i.e., ϑ = 0 is normal to probe axis
Connector Angle	information used in DASY system to align probe sensor X to the robot coordinate system

Calibration is Performed According to the Following Standards:

- a) IEEE Std 1528-2013, "IEEE Recommended Practice for Determining the Peak Spatial-Averaged Specific Absorption Rate (SAR) in the Human Head from Wireless Communications Devices: Measurement Techniques", June 2013
- b) IEC 62209-1, "Procedure to measure the Specific Absorption Rate (SAR) for hand-held devices used in close proximity to the ear (frequency range of 300 MHz to 3 GHz)", February 2005
- c) IEC 62209-2, "Procedure to determine the Specific Absorption Rate (SAR) for wireless communication devices used in close proximity to the human body (frequency range of 30 MHz to 6 GHz)", March 2010
- d) KDB 865664, "SAR Measurement Requirements for 100 MHz to 6 GHz"

Methods Applied and Interpretation of Parameters:

- *NORM_{x,y,z}*: Assessed for E-field polarization ϑ = 0 (f ≤ 900 MHz in TEM-cell; f > 1800 MHz: R22 waveguide). NORM_{x,y,z} are only intermediate values, i.e., the uncertainties of NORM_{x,y,z} does not affect the E²-field uncertainty inside TSL (see below *ConvF*).
- *NORM(f)_{x,y,z}* = *NORM_{x,y,z}* * *frequency_response* (see Frequency Response Chart). This linearization is implemented in DASY4 software versions later than 4.2. The uncertainty of the frequency response is included in the stated uncertainty of *ConvF*.
- *DCP_{x,y,z}*: DCP are numerical linearization parameters assessed based on the data of power sweep with CW signal (no uncertainty required). DCP does not depend on frequency nor media.
- *PAR*: PAR is the Peak to Average Ratio that is not calibrated but determined based on the signal characteristics
- *A_{x,y,z}; B_{x,y,z}; C_{x,y,z}; D_{x,y,z}; VR_{x,y,z}*: A, B, C, D are numerical linearization parameters assessed based on the data of power sweep for specific modulation signal. The parameters do not depend on frequency nor media. VR is the maximum calibration range expressed in RMS voltage across the diode.
- *ConvF and Boundary Effect Parameters*: Assessed in flat phantom using E-field (or Temperature Transfer Standard for f ≤ 800 MHz) and inside waveguide using analytical field distributions based on power measurements for f > 800 MHz. The same setups are used for assessment of the parameters applied for boundary compensation (alpha, depth) of which typical uncertainty values are given. These parameters are used in DASY4 software to improve probe accuracy close to the boundary. The sensitivity in TSL corresponds to *NORM_{x,y,z}* * *ConvF* whereby the uncertainty corresponds to that given for *ConvF*. A frequency dependent *ConvF* is used in DASY version 4.4 and higher which allows extending the validity from ± 50 MHz to ± 100 MHz.
- *Spherical isotropy (3D deviation from isotropy)*: in a field of low gradients realized using a flat phantom exposed by a patch antenna.
- *Sensor Offset*: The sensor offset corresponds to the offset of virtual measurement center from the probe tip (on probe axis). No tolerance required.
- *Connector Angle*: The angle is assessed using the information gained by determining the *NORM_x* (no uncertainty required).

Probe EX3DV4

SN:3914

Manufactured: December 18, 2012
Calibrated: February 13, 2017

Calibrated for DASY/EASY Systems
(Note: non-compatible with DASY2 system!)

DASY/EASY - Parameters of Probe: EX3DV4 - SN:3914

Basic Calibration Parameters

	Sensor X	Sensor Y	Sensor Z	Unc (k=2)
Norm ($\mu\text{V}/(\text{V}/\text{m})^2$) ^A	0.46	0.41	0.44	$\pm 10.1 \%$
DCP (mV) ^B	98.6	102.5	103.7	

Modulation Calibration Parameters

UID	Communication System Name		A dB	B dB $\sqrt{\mu\text{V}}$	C	D dB	VR mV	Unc ^E (k=2)
0	CW	X	0.0	0.0	1.0	0.00	156.6	$\pm 3.3 \%$
		Y	0.0	0.0	1.0		139.0	
		Z	0.0	0.0	1.0		149.0	

Note: For details on UID parameters see Appendix.

Sensor Model Parameters

	C1 fF	C2 fF	α V^{-1}	T1 $\text{ms}\cdot\text{V}^{-2}$	T2 $\text{ms}\cdot\text{V}^{-1}$	T3 ms	T4 V^{-2}	T5 V^{-1}	T6
X	46.19	344.3	35.58	12.88	0.995	4.971	0.985	0.325	1.004
Y	48.34	356	34.87	12.19	1.102	4.961	0.683	0.315	1.003
Z	44.31	328.7	35.26	10.14	1.122	4.975	1.527	0.227	1.005

The reported uncertainty of measurement is stated as the standard uncertainty of measurement multiplied by the coverage factor $k=2$, which for a normal distribution corresponds to a coverage probability of approximately 95%.

^A The uncertainties of Norm X,Y,Z do not affect the E^2 -field uncertainty inside TSL (see Pages 5 and 6).

^B Numerical linearization parameter: uncertainty not required.

^E Uncertainty is determined using the max. deviation from linear response applying rectangular distribution and is expressed for the square of the field value.

DASY/EASY - Parameters of Probe: EX3DV4 - SN:3914

Calibration Parameter Determined in Head Tissue Simulating Media

f (MHz) ^C	Relative Permittivity ^F	Conductivity (S/m) ^F	ConvF X	ConvF Y	ConvF Z	Alpha ^G	Depth ^G (mm)	Unc (k=2)
6	55.5	0.75	21.32	21.32	21.32	0.00	1.00	± 13.3 %
13	55.5	0.75	17.87	17.87	17.87	0.00	1.00	± 13.3 %
5250	35.9	4.71	5.49	5.49	5.49	0.30	1.80	± 13.1 %
5600	35.5	5.07	4.94	4.94	4.94	0.40	1.80	± 13.1 %
5750	35.4	5.22	4.91	4.91	4.91	0.40	1.80	± 13.1 %

^C Frequency validity above 300 MHz of ± 100 MHz only applies for DASY v4.4 and higher (see Page 2), else it is restricted to ± 50 MHz. The uncertainty is the RSS of the ConvF uncertainty at calibration frequency and the uncertainty for the indicated frequency band. Frequency validity below 300 MHz is ± 10, 25, 40, 50 and 70 MHz for ConvF assessments at 30, 64, 128, 150 and 220 MHz respectively. Validity of ConvF assessed at 6 MHz is 4-9 MHz, and ConvF assessed at 13 MHz is 9-19 MHz. Above 5 GHz frequency validity can be extended to ± 110 MHz.

^F At frequencies below 3 GHz, the validity of tissue parameters (ϵ and σ) can be relaxed to ± 10% if liquid compensation formula is applied to measured SAR values. At frequencies above 3 GHz, the validity of tissue parameters (ϵ and σ) is restricted to ± 5%. The uncertainty is the RSS of the ConvF uncertainty for indicated target tissue parameters.

^G Alpha/Depth are determined during calibration. SPEAG warrants that the remaining deviation due to the boundary effect after compensation is always less than ± 1% for frequencies below 3 GHz and below ± 2% for frequencies between 3-6 GHz at any distance larger than half the probe tip diameter from the boundary.

DASY/EASY - Parameters of Probe: EX3DV4 - SN:3914

Calibration Parameter Determined in Body Tissue Simulating Media

f (MHz) ^C	Relative Permittivity ^F	Conductivity (S/m) ^F	ConvF X	ConvF Y	ConvF Z	Alpha ^G	Depth ^G (mm)	Unc (k=2)
750	55.5	0.96	9.98	9.98	9.98	0.45	0.88	± 12.0 %
835	55.2	0.97	9.73	9.73	9.73	0.40	0.88	± 12.0 %
1750	53.4	1.49	8.01	8.01	8.01	0.32	1.02	± 12.0 %
1900	53.3	1.52	7.75	7.75	7.75	0.34	0.95	± 12.0 %
2300	52.9	1.81	7.56	7.56	7.56	0.44	0.80	± 12.0 %
2450	52.7	1.95	7.45	7.45	7.45	0.35	0.90	± 12.0 %
2600	52.5	2.16	7.24	7.24	7.24	0.29	0.95	± 12.0 %
5250	48.9	5.36	4.78	4.78	4.78	0.40	1.90	± 13.1 %
5600	48.5	5.77	4.07	4.07	4.07	0.45	1.90	± 13.1 %
5750	48.3	5.94	4.15	4.15	4.15	0.50	1.90	± 13.1 %

^C Frequency validity above 300 MHz of ± 100 MHz only applies for DASY v4.4 and higher (see Page 2), else it is restricted to ± 50 MHz. The uncertainty is the RSS of the ConvF uncertainty at calibration frequency and the uncertainty for the indicated frequency band. Frequency validity below 300 MHz is ± 10, 25, 40, 50 and 70 MHz for ConvF assessments at 30, 64, 128, 150 and 220 MHz respectively. Above 5 GHz frequency validity can be extended to ± 110 MHz.

^F At frequencies below 3 GHz, the validity of tissue parameters (ϵ and σ) can be relaxed to ± 10% if liquid compensation formula is applied to measured SAR values. At frequencies above 3 GHz, the validity of tissue parameters (ϵ and σ) is restricted to ± 5%. The uncertainty is the RSS of the ConvF uncertainty for indicated target tissue parameters.

^G Alpha/Depth are determined during calibration. SPEAG warrants that the remaining deviation due to the boundary effect after compensation is always less than ± 1% for frequencies below 3 GHz and below ± 2% for frequencies between 3-6 GHz at any distance larger than half the probe tip diameter from the boundary.

Frequency Response of E-Field (TEM-Cell:ifi1110 EXX, Waveguide: R22)

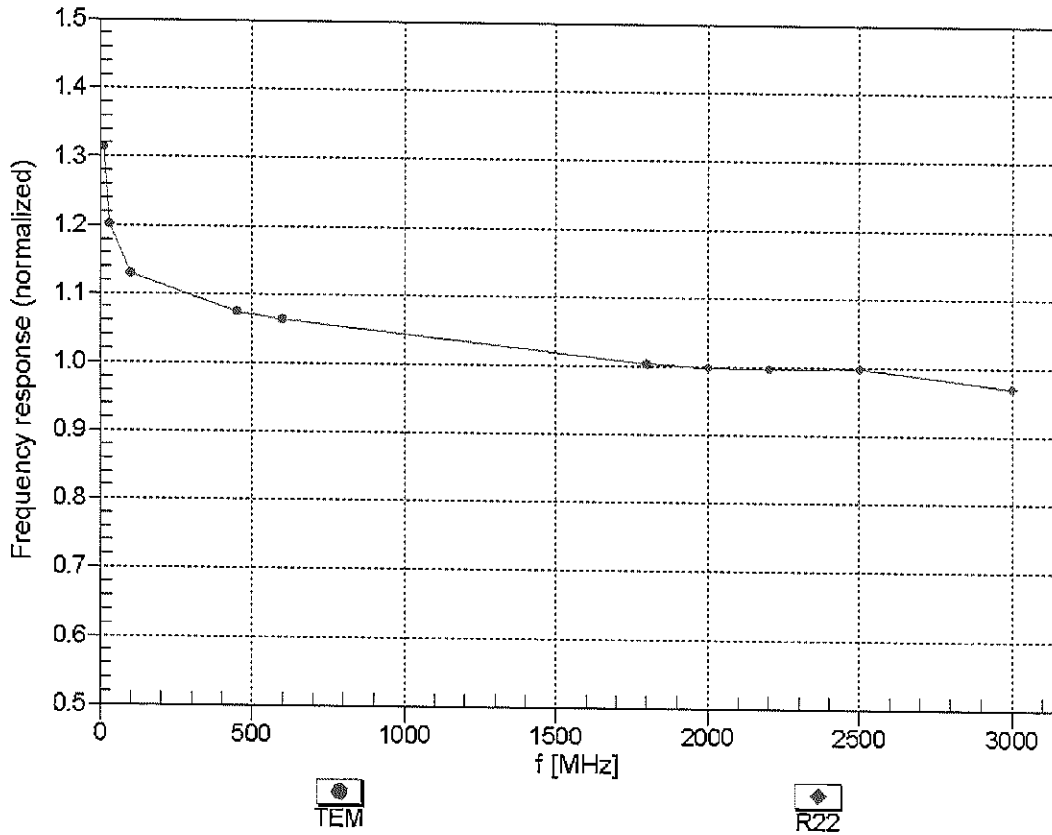

Uncertainty of Frequency Response of E-field: $\pm 6.3\%$ (k=2)

Receiving Pattern (ϕ), $\theta = 0^\circ$

f=600 MHz,TEM

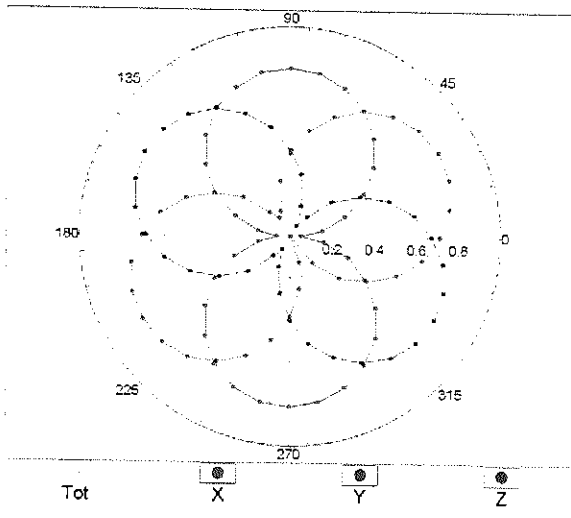

f=1800 MHz,R22

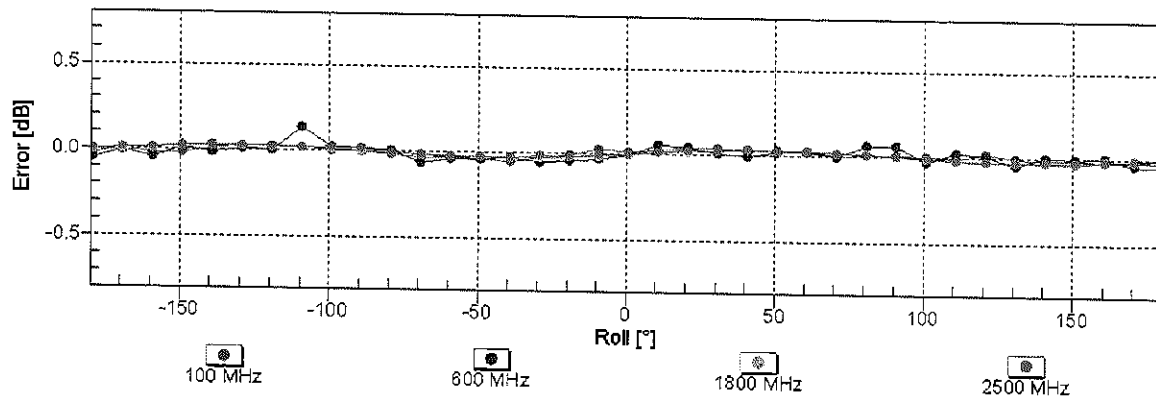
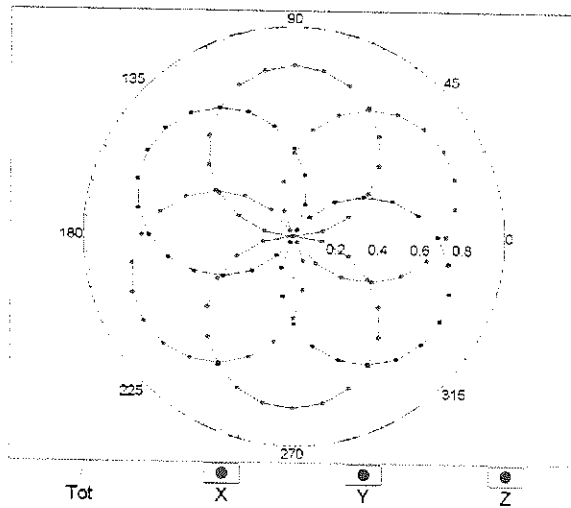

Uncertainty of Axial Isotropy Assessment: $\pm 0.5\%$ (k=2)

Dynamic Range f(SAR_{head}) (TEM cell , f_{eval}= 1900 MHz)

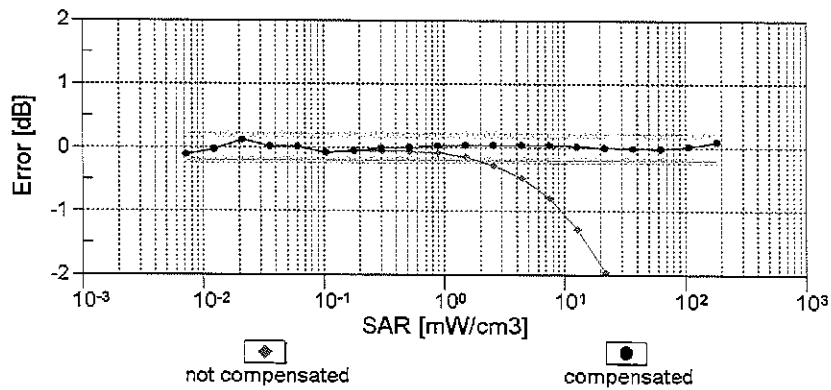
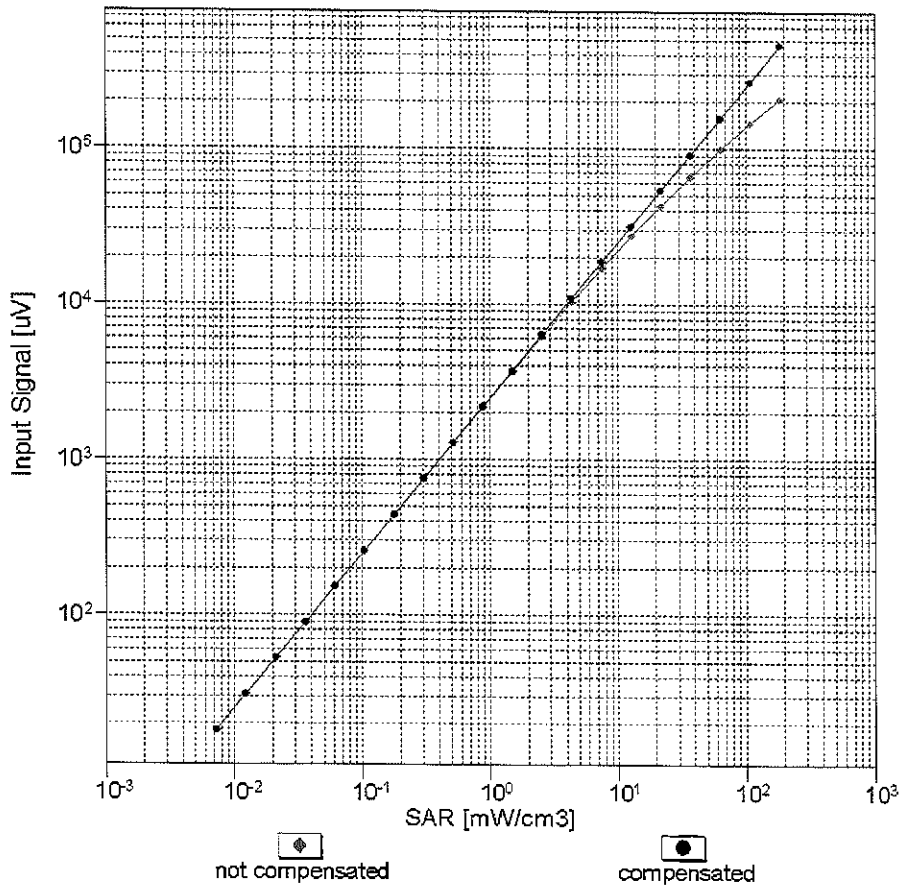

Uncertainty of Linearity Assessment: ± 0.6% (k=2)

Conversion Factor Assessment

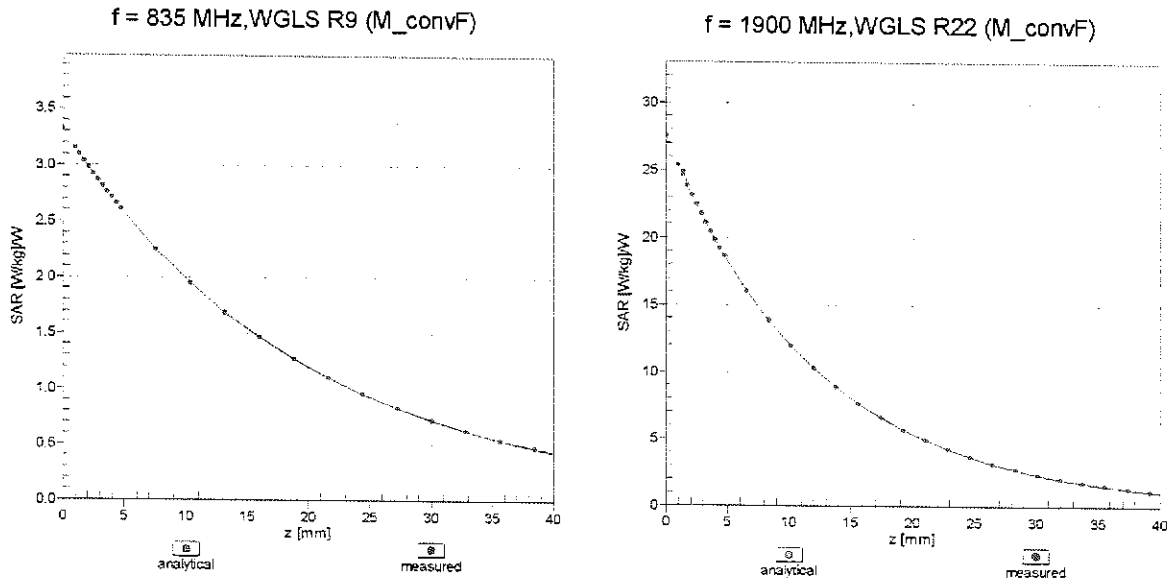

Deviation from Isotropy in Liquid Error (ϕ, ϑ), f = 900 MHz

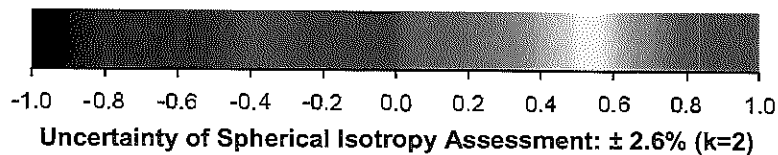
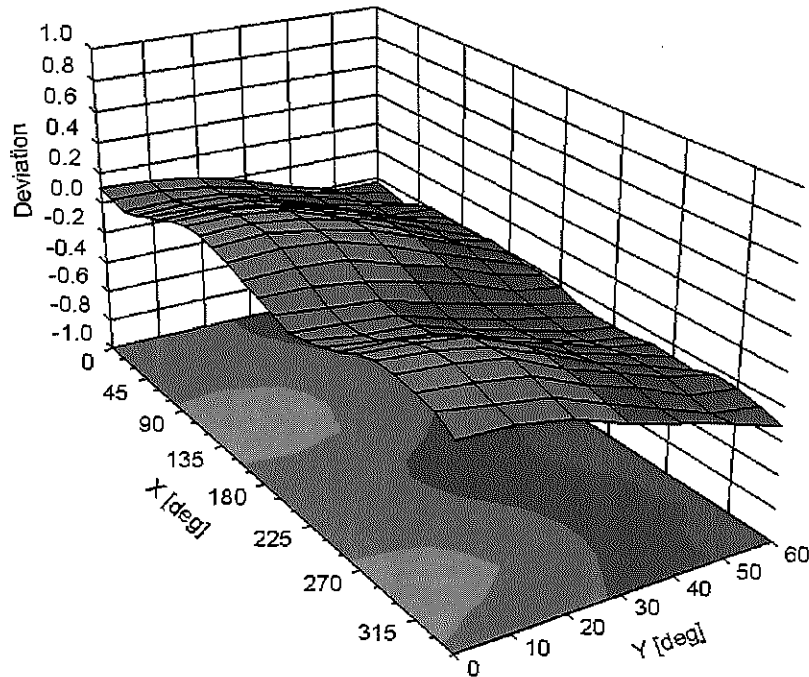

DASY/EASY - Parameters of Probe: EX3DV4 - SN:3914

Other Probe Parameters

Sensor Arrangement	Triangular
Connector Angle (°)	130.8
Mechanical Surface Detection Mode	enabled
Optical Surface Detection Mode	disabled
Probe Overall Length	337 mm
Probe Body Diameter	10 mm
Tip Length	9 mm
Tip Diameter	2.5 mm
Probe Tip to Sensor X Calibration Point	1 mm
Probe Tip to Sensor Y Calibration Point	1 mm
Probe Tip to Sensor Z Calibration Point	1 mm
Recommended Measurement Distance from Surface	1.4 mm

Appendix: Modulation Calibration Parameters

UID	Communication System Name		A dB	B dB $\sqrt{\mu}$ V	C	D dB	VR mV	Max Unc ^E (k=2)
0	CW	X	0.00	0.00	1.00	0.00	156.6	$\pm 3.3\%$
		Y	0.00	0.00	1.00		139.0	
		Z	0.00	0.00	1.00		149.0	
10010- CAA	SAR Validation (Square, 100ms, 10ms)	X	2.67	66.07	10.73	10.00	20.0	$\pm 9.6\%$
		Y	2.77	66.16	10.84		20.0	
		Z	3.01	67.22	11.52		20.0	
10011- CAB	UMTS-FDD (WCDMA)	X	1.07	68.17	15.86	0.00	150.0	$\pm 9.6\%$
		Y	1.14	69.43	16.60		150.0	
		Z	1.05	67.81	15.63		150.0	
10012- CAB	IEEE 802.11b WiFi 2.4 GHz (DSSS, 1 Mbps)	X	1.18	63.94	15.29	0.41	150.0	$\pm 9.6\%$
		Y	1.19	64.27	15.54		150.0	
		Z	1.17	63.79	15.16		150.0	
10013- CAB	IEEE 802.11g WiFi 2.4 GHz (DSSS-OFDM, 6 Mbps)	X	4.82	66.52	16.88	1.46	150.0	$\pm 9.6\%$
		Y	4.84	66.55	16.88		150.0	
		Z	4.80	66.54	16.86		150.0	
10021- DAC	GSM-FDD (TDMA, GMSK)	X	10.62	83.12	18.62	9.39	50.0	$\pm 9.6\%$
		Y	8.33	79.79	17.55		50.0	
		Z	13.42	86.52	20.09		50.0	
10023- DAC	GPRS-FDD (TDMA, GMSK, TN 0)	X	8.76	80.53	17.78	9.57	50.0	$\pm 9.6\%$
		Y	7.40	78.13	16.99		50.0	
		Z	10.55	83.20	19.04		50.0	
10024- DAC	GPRS-FDD (TDMA, GMSK, TN 0-1)	X	21.17	91.31	19.68	6.56	60.0	$\pm 9.6\%$
		Y	12.07	85.13	17.96		60.0	
		Z	52.32	102.57	22.98		60.0	
10025- DAC	EDGE-FDD (TDMA, 8PSK, TN 0)	X	4.95	72.82	26.24	12.57	50.0	$\pm 9.6\%$
		Y	7.53	84.57	31.77		50.0	
		Z	4.80	71.26	25.29		50.0	
10026- DAC	EDGE-FDD (TDMA, 8PSK, TN 0-1)	X	8.84	88.73	30.42	9.56	60.0	$\pm 9.6\%$
		Y	10.05	91.59	31.44		60.0	
		Z	8.11	86.61	29.62		60.0	
10027- DAC	GPRS-FDD (TDMA, GMSK, TN 0-1-2)	X	100.00	106.86	22.53	4.80	80.0	$\pm 9.6\%$
		Y	100.00	106.55	22.42		80.0	
		Z	100.00	109.38	23.65		80.0	
10028- DAC	GPRS-FDD (TDMA, GMSK, TN 0-1-2-3)	X	100.00	107.35	22.11	3.55	100.0	$\pm 9.6\%$
		Y	100.00	107.02	21.99		100.0	
		Z	100.00	110.40	23.40		100.0	
10029- DAC	EDGE-FDD (TDMA, 8PSK, TN 0-1-2)	X	5.77	79.87	25.94	7.80	80.0	$\pm 9.6\%$
		Y	6.21	81.41	26.54		80.0	
		Z	5.35	78.22	25.29		80.0	
10030- CAA	IEEE 802.15.1 Bluetooth (GFSK, DH1)	X	13.42	86.20	17.57	5.30	70.0	$\pm 9.6\%$
		Y	9.31	82.44	16.50		70.0	
		Z	29.70	95.60	20.46		70.0	
10031- CAA	IEEE 802.15.1 Bluetooth (GFSK, DH3)	X	100.00	106.43	20.54	1.88	100.0	$\pm 9.6\%$
		Y	100.00	106.56	20.60		100.0	
		Z	100.00	109.99	21.95		100.0	

10032-CAA	IEEE 802.15.1 Bluetooth (GFSK, DH5)	X	100.00	112.98	22.39	1.17	100.0	± 9.6 %
		Y	100.00	114.09	22.82		100.0	
		Z	100.00	117.75	24.22		100.0	
10033-CAA	IEEE 802.15.1 Bluetooth (PI/4-DQPSK, DH1)	X	5.28	79.65	19.49	5.30	70.0	± 9.6 %
		Y	5.39	79.85	19.61		70.0	
		Z	4.87	78.68	19.23		70.0	
10034-CAA	IEEE 802.15.1 Bluetooth (PI/4-DQPSK, DH3)	X	2.39	73.05	16.10	1.88	100.0	± 9.6 %
		Y	2.51	73.86	16.59		100.0	
		Z	2.22	72.28	15.77		100.0	
10035-CAA	IEEE 802.15.1 Bluetooth (PI/4-DQPSK, DH5)	X	1.86	71.23	15.30	1.17	100.0	± 9.6 %
		Y	1.97	72.22	15.90		100.0	
		Z	1.74	70.56	14.96		100.0	
10036-CAA	IEEE 802.15.1 Bluetooth (8-DPSK, DH1)	X	6.16	82.06	20.41	5.30	70.0	± 9.6 %
		Y	6.25	82.19	20.50		70.0	
		Z	5.60	80.92	20.11		70.0	
10037-CAA	IEEE 802.15.1 Bluetooth (8-DPSK, DH3)	X	2.26	72.39	15.80	1.88	100.0	± 9.6 %
		Y	2.37	73.21	16.30		100.0	
		Z	2.09	71.60	15.47		100.0	
10038-CAA	IEEE 802.15.1 Bluetooth (8-DPSK, DH5)	X	1.87	71.57	15.55	1.17	100.0	± 9.6 %
		Y	2.00	72.59	16.17		100.0	
		Z	1.75	70.84	15.19		100.0	
10039-CAB	CDMA2000 (1xRTT, RC1)	X	2.22	74.99	16.99	0.00	150.0	± 9.6 %
		Y	2.65	77.61	18.26		150.0	
		Z	2.08	74.23	16.52		150.0	
10042-CAB	IS-54 / IS-136 FDD (TDMA/FDM, PI/4-DQPSK, Halfrate)	X	7.56	79.14	16.13	7.78	50.0	± 9.6 %
		Y	6.34	77.01	15.44		50.0	
		Z	11.33	84.23	18.10		50.0	
10044-CAA	IS-91/EIA/TIA-553 FDD (FDMA, FM)	X	0.00	97.59	0.84	0.00	150.0	± 9.6 %
		Y	0.00	98.99	0.04		150.0	
		Z	0.00	96.10	0.72		150.0	
10048-CAA	DECT (TDD, TDMA/FDM, GFSK, Full Slot, 24)	X	6.44	73.35	16.60	13.80	25.0	± 9.6 %
		Y	6.16	72.26	16.24		25.0	
		Z	7.34	74.65	17.41		25.0	
10049-CAA	DECT (TDD, TDMA/FDM, GFSK, Double Slot, 12)	X	6.68	76.08	16.45	10.79	40.0	± 9.6 %
		Y	6.26	74.90	16.07		40.0	
		Z	7.59	77.73	17.40		40.0	
10056-CAA	UMTS-TDD (TD-SCDMA, 1.28 Mcps)	X	8.65	81.91	20.55	9.03	50.0	± 9.6 %
		Y	8.47	81.27	20.33		50.0	
		Z	8.59	81.70	20.58		50.0	
10058-DAC	EDGE-FDD (TDMA, 8PSK, TN 0-1-2-3)	X	4.50	75.41	23.42	6.55	100.0	± 9.6 %
		Y	4.71	76.39	23.81		100.0	
		Z	4.21	74.08	22.88		100.0	
10059-CAB	IEEE 802.11b WiFi 2.4 GHz (DSSS, 2 Mbps)	X	1.22	64.88	15.72	0.61	110.0	± 9.6 %
		Y	1.23	65.26	15.98		110.0	
		Z	1.20	64.63	15.56		110.0	
10060-CAB	IEEE 802.11b WiFi 2.4 GHz (DSSS, 5.5 Mbps)	X	5.20	91.89	23.64	1.30	110.0	± 9.6 %
		Y	8.22	98.67	25.63		110.0	
		Z	3.57	87.17	22.39		110.0	

10061-CAB	IEEE 802.11b WiFi 2.4 GHz (DSSS, 11 Mbps)	X	2.42	76.11	19.87	2.04	110.0	± 9.6 %
		Y	2.58	77.18	20.29		110.0	
		Z	2.18	74.61	19.37		110.0	
10062-CAB	IEEE 802.11a/h WiFi 5 GHz (OFDM, 6 Mbps)	X	4.65	66.63	16.45	0.49	100.0	± 9.6 %
		Y	4.67	66.69	16.47		100.0	
		Z	4.63	66.64	16.42		100.0	
10063-CAB	IEEE 802.11a/h WiFi 5 GHz (OFDM, 9 Mbps)	X	4.66	66.68	16.51	0.72	100.0	± 9.6 %
		Y	4.68	66.74	16.53		100.0	
		Z	4.63	66.69	16.48		100.0	
10064-CAB	IEEE 802.11a/h WiFi 5 GHz (OFDM, 12 Mbps)	X	4.94	66.91	16.71	0.86	100.0	± 9.6 %
		Y	4.96	66.98	16.73		100.0	
		Z	4.91	66.92	16.68		100.0	
10065-CAB	IEEE 802.11a/h WiFi 5 GHz (OFDM, 18 Mbps)	X	4.80	66.77	16.76	1.21	100.0	± 9.6 %
		Y	4.82	66.84	16.78		100.0	
		Z	4.77	66.77	16.73		100.0	
10066-CAB	IEEE 802.11a/h WiFi 5 GHz (OFDM, 24 Mbps)	X	4.81	66.75	16.88	1.46	100.0	± 9.6 %
		Y	4.83	66.82	16.89		100.0	
		Z	4.78	66.75	16.85		100.0	
10067-CAB	IEEE 802.11a/h WiFi 5 GHz (OFDM, 36 Mbps)	X	5.09	66.88	17.26	2.04	100.0	± 9.6 %
		Y	5.11	66.92	17.27		100.0	
		Z	5.07	66.91	17.25		100.0	
10068-CAB	IEEE 802.11a/h WiFi 5 GHz (OFDM, 48 Mbps)	X	5.13	66.89	17.43	2.55	100.0	± 9.6 %
		Y	5.16	66.96	17.45		100.0	
		Z	5.10	66.89	17.41		100.0	
10069-CAB	IEEE 802.11a/h WiFi 5 GHz (OFDM, 54 Mbps)	X	5.21	66.88	17.61	2.67	100.0	± 9.6 %
		Y	5.23	66.94	17.62		100.0	
		Z	5.18	66.90	17.59		100.0	
10071-CAB	IEEE 802.11g WiFi 2.4 GHz (DSSS/OFDM, 9 Mbps)	X	4.91	66.56	17.12	1.99	100.0	± 9.6 %
		Y	4.92	66.60	17.13		100.0	
		Z	4.89	66.58	17.10		100.0	
10072-CAB	IEEE 802.11g WiFi 2.4 GHz (DSSS/OFDM, 12 Mbps)	X	4.88	66.83	17.29	2.30	100.0	± 9.6 %
		Y	4.90	66.89	17.30		100.0	
		Z	4.86	66.85	17.27		100.0	
10073-CAB	IEEE 802.11g WiFi 2.4 GHz (DSSS/OFDM, 18 Mbps)	X	4.94	66.95	17.56	2.83	100.0	± 9.6 %
		Y	4.95	67.01	17.56		100.0	
		Z	4.92	66.98	17.54		100.0	
10074-CAB	IEEE 802.11g WiFi 2.4 GHz (DSSS/OFDM, 24 Mbps)	X	4.92	66.84	17.68	3.30	100.0	± 9.6 %
		Y	4.94	66.89	17.68		100.0	
		Z	4.91	66.87	17.66		100.0	
10075-CAB	IEEE 802.11g WiFi 2.4 GHz (DSSS/OFDM, 36 Mbps)	X	4.96	66.95	17.95	3.82	90.0	± 9.6 %
		Y	4.99	67.03	17.97		90.0	
		Z	4.95	66.97	17.93		90.0	
10076-CAB	IEEE 802.11g WiFi 2.4 GHz (DSSS/OFDM, 48 Mbps)	X	4.98	66.76	18.06	4.15	90.0	± 9.6 %
		Y	5.00	66.82	18.07		90.0	
		Z	4.98	66.79	18.06		90.0	
10077-CAB	IEEE 802.11g WiFi 2.4 GHz (DSSS/OFDM, 54 Mbps)	X	5.01	66.82	18.15	4.30	90.0	± 9.6 %
		Y	5.02	66.89	18.16		90.0	
		Z	5.01	66.87	18.15		90.0	

10081-CAB	CDMA2000 (1xRTT, RC3)	X	0.92	67.41	13.37	0.00	150.0	± 9.6 %
		Y	1.03	69.09	14.44		150.0	
		Z	0.88	66.94	12.99		150.0	
10082-CAB	IS-54 / IS-136 FDD (TDMA/FDM, PI/4-DQPSK, Fullrate)	X	0.63	57.80	3.24	4.77	80.0	± 9.6 %
		Y	0.66	58.21	3.60		80.0	
		Z	0.62	57.96	3.46		80.0	
10090-DAC	GPRS-FDD (TDMA, GMSK, TN 0-4)	X	20.08	90.74	19.54	6.56	60.0	± 9.6 %
		Y	11.65	84.73	17.86		60.0	
		Z	47.95	101.61	22.77		60.0	
10097-CAB	UMTS-FDD (HSDPA)	X	1.89	68.37	16.12	0.00	150.0	± 9.6 %
		Y	1.94	68.91	16.47		150.0	
		Z	1.87	68.28	16.00		150.0	
10098-CAB	UMTS-FDD (HSUPA, Subtest 2)	X	1.85	68.32	16.09	0.00	150.0	± 9.6 %
		Y	1.90	68.87	16.45		150.0	
		Z	1.83	68.22	15.96		150.0	
10099-DAC	EDGE-FDD (TDMA, 8PSK, TN 0-4)	X	8.88	88.80	30.43	9.56	60.0	± 9.6 %
		Y	10.09	91.64	31.45		60.0	
		Z	8.15	86.66	29.63		60.0	
10100-CAC	LTE-FDD (SC-FDMA, 100% RB, 20 MHz, QPSK)	X	3.20	70.80	17.02	0.00	150.0	± 9.6 %
		Y	3.31	71.44	17.31		150.0	
		Z	3.15	70.62	16.92		150.0	
10101-CAC	LTE-FDD (SC-FDMA, 100% RB, 20 MHz, 16-QAM)	X	3.26	67.72	16.10	0.00	150.0	± 9.6 %
		Y	3.31	68.03	16.26		150.0	
		Z	3.23	67.65	16.04		150.0	
10102-CAC	LTE-FDD (SC-FDMA, 100% RB, 20 MHz, 64-QAM)	X	3.37	67.70	16.20	0.00	150.0	± 9.6 %
		Y	3.41	67.97	16.34		150.0	
		Z	3.34	67.64	16.14		150.0	
10103-CAC	LTE-TDD (SC-FDMA, 100% RB, 20 MHz, QPSK)	X	6.10	74.42	19.52	3.98	65.0	± 9.6 %
		Y	5.87	73.66	19.14		65.0	
		Z	5.74	73.57	19.22		65.0	
10104-CAC	LTE-TDD (SC-FDMA, 100% RB, 20 MHz, 16-QAM)	X	6.15	72.80	19.65	3.98	65.0	± 9.6 %
		Y	6.23	72.96	19.68		65.0	
		Z	5.94	72.31	19.46		65.0	
10105-CAC	LTE-TDD (SC-FDMA, 100% RB, 20 MHz, 64-QAM)	X	5.87	71.80	19.52	3.98	65.0	± 9.6 %
		Y	5.67	71.06	19.13		65.0	
		Z	5.56	70.91	19.13		65.0	
10108-CAD	LTE-FDD (SC-FDMA, 100% RB, 10 MHz, QPSK)	X	2.79	70.03	16.86	0.00	150.0	± 9.6 %
		Y	2.88	70.63	17.15		150.0	
		Z	2.74	69.86	16.75		150.0	
10109-CAD	LTE-FDD (SC-FDMA, 100% RB, 10 MHz, 16-QAM)	X	2.92	67.64	16.04	0.00	150.0	± 9.6 %
		Y	2.97	67.95	16.22		150.0	
		Z	2.89	67.57	15.96		150.0	
10110-CAD	LTE-FDD (SC-FDMA, 100% RB, 5 MHz, QPSK)	X	2.26	69.17	16.48	0.00	150.0	± 9.6 %
		Y	2.35	69.78	16.82		150.0	
		Z	2.22	68.99	16.35		150.0	
10111-CAD	LTE-FDD (SC-FDMA, 100% RB, 5 MHz, 16-QAM)	X	2.67	68.78	16.48	0.00	150.0	± 9.6 %
		Y	2.73	69.09	16.70		150.0	
		Z	2.65	68.73	16.39		150.0	

10112-CAD	LTE-FDD (SC-FDMA, 100% RB, 10 MHz, 64-QAM)	X	3.05	67.64	16.10	0.00	150.0	± 9.6 %
		Y	3.10	67.91	16.26		150.0	
		Z	3.02	67.58	16.03		150.0	
10113-CAD	LTE-FDD (SC-FDMA, 100% RB, 5 MHz, 64-QAM)	X	2.83	68.92	16.61	0.00	150.0	± 9.6 %
		Y	2.88	69.19	16.80		150.0	
		Z	2.80	68.89	16.53		150.0	
10114-CAB	IEEE 802.11n (HT Greenfield, 13.5 Mbps, BPSK)	X	5.14	67.30	16.52	0.00	150.0	± 9.6 %
		Y	5.15	67.37	16.54		150.0	
		Z	5.11	67.28	16.49		150.0	
10115-CAB	IEEE 802.11n (HT Greenfield, 81 Mbps, 16-QAM)	X	5.41	67.39	16.58	0.00	150.0	± 9.6 %
		Y	5.44	67.49	16.61		150.0	
		Z	5.37	67.35	16.53		150.0	
10116-CAB	IEEE 802.11n (HT Greenfield, 135 Mbps, 64-QAM)	X	5.23	67.48	16.54	0.00	150.0	± 9.6 %
		Y	5.25	67.56	16.57		150.0	
		Z	5.20	67.46	16.50		150.0	
10117-CAB	IEEE 802.11n (HT Mixed, 13.5 Mbps, BPSK)	X	5.10	67.15	16.47	0.00	150.0	± 9.6 %
		Y	5.12	67.24	16.50		150.0	
		Z	5.07	67.14	16.44		150.0	
10118-CAB	IEEE 802.11n (HT Mixed, 81 Mbps, 16-QAM)	X	5.49	67.59	16.68	0.00	150.0	± 9.6 %
		Y	5.52	67.68	16.71		150.0	
		Z	5.45	67.53	16.63		150.0	
10119-CAB	IEEE 802.11n (HT Mixed, 135 Mbps, 64-QAM)	X	5.21	67.43	16.53	0.00	150.0	± 9.6 %
		Y	5.22	67.50	16.55		150.0	
		Z	5.18	67.41	16.49		150.0	
10140-CAC	LTE-FDD (SC-FDMA, 100% RB, 15 MHz, 16-QAM)	X	3.40	67.70	16.11	0.00	150.0	± 9.6 %
		Y	3.45	67.97	16.25		150.0	
		Z	3.37	67.64	16.05		150.0	
10141-CAC	LTE-FDD (SC-FDMA, 100% RB, 15 MHz, 64-QAM)	X	3.53	67.82	16.29	0.00	150.0	± 9.6 %
		Y	3.57	68.05	16.41		150.0	
		Z	3.50	67.77	16.23		150.0	
10142-CAD	LTE-FDD (SC-FDMA, 100% RB, 3 MHz, QPSK)	X	2.05	69.36	16.22	0.00	150.0	± 9.6 %
		Y	2.15	70.07	16.65		150.0	
		Z	2.01	69.16	16.05		150.0	
10143-CAD	LTE-FDD (SC-FDMA, 100% RB, 3 MHz, 16-QAM)	X	2.58	69.85	16.32	0.00	150.0	± 9.6 %
		Y	2.67	70.31	16.66		150.0	
		Z	2.55	69.76	16.17		150.0	
10144-CAD	LTE-FDD (SC-FDMA, 100% RB, 3 MHz, 64-QAM)	X	2.27	67.04	14.44	0.00	150.0	± 9.6 %
		Y	2.35	67.51	14.81		150.0	
		Z	2.23	66.89	14.26		150.0	
10145-CAD	LTE-FDD (SC-FDMA, 100% RB, 1.4 MHz, QPSK)	X	1.27	65.89	12.21	0.00	150.0	± 9.6 %
		Y	1.42	67.33	13.21		150.0	
		Z	1.20	65.32	11.71		150.0	
10146-CAD	LTE-FDD (SC-FDMA, 100% RB, 1.4 MHz, 16-QAM)	X	1.76	65.12	10.79	0.00	150.0	± 9.6 %
		Y	1.85	65.98	11.50		150.0	
		Z	1.79	65.33	10.70		150.0	
10147-CAD	LTE-FDD (SC-FDMA, 100% RB, 1.4 MHz, 64-QAM)	X	2.02	66.77	11.72	0.00	150.0	± 9.6 %
		Y	2.20	68.07	12.63		150.0	
		Z	2.10	67.13	11.69		150.0	

10149-CAC	LTE-FDD (SC-FDMA, 50% RB, 20 MHz, 16-QAM)	X	2.93	67.71	16.09	0.00	150.0	± 9.6 %
		Y	2.98	68.02	16.27		150.0	
		Z	2.90	67.64	16.02		150.0	
10150-CAC	LTE-FDD (SC-FDMA, 50% RB, 20 MHz, 64-QAM)	X	3.06	67.71	16.14	0.00	150.0	± 9.6 %
		Y	3.10	67.97	16.30		150.0	
		Z	3.03	67.65	16.07		150.0	
10151-CAC	LTE-TDD (SC-FDMA, 50% RB, 20 MHz, QPSK)	X	6.20	76.14	20.26	3.98	65.0	± 9.6 %
		Y	6.27	76.18	20.22		65.0	
		Z	5.93	75.60	20.10		65.0	
10152-CAC	LTE-TDD (SC-FDMA, 50% RB, 20 MHz, 16-QAM)	X	5.64	72.55	19.21	3.98	65.0	± 9.6 %
		Y	5.73	72.74	19.28		65.0	
		Z	5.43	72.04	19.00		65.0	
10153-CAC	LTE-TDD (SC-FDMA, 50% RB, 20 MHz, 64-QAM)	X	6.03	73.59	20.04	3.98	65.0	± 9.6 %
		Y	6.10	73.69	20.06		65.0	
		Z	5.81	73.08	19.84		65.0	
10154-CAD	LTE-FDD (SC-FDMA, 50% RB, 10 MHz, QPSK)	X	2.32	69.68	16.78	0.00	150.0	± 9.6 %
		Y	2.41	70.30	17.13		150.0	
		Z	2.28	69.49	16.65		150.0	
10155-CAD	LTE-FDD (SC-FDMA, 50% RB, 10 MHz, 16-QAM)	X	2.68	68.79	16.50	0.00	150.0	± 9.6 %
		Y	2.73	69.11	16.71		150.0	
		Z	2.65	68.75	16.41		150.0	
10156-CAD	LTE-FDD (SC-FDMA, 50% RB, 5 MHz, QPSK)	X	1.92	69.63	16.09	0.00	150.0	± 9.6 %
		Y	2.03	70.50	16.63		150.0	
		Z	1.87	69.37	15.88		150.0	
10157-CAD	LTE-FDD (SC-FDMA, 50% RB, 5 MHz, 16-QAM)	X	2.14	67.82	14.58	0.00	150.0	± 9.6 %
		Y	2.24	68.46	15.06		150.0	
		Z	2.09	67.62	14.35		150.0	
10158-CAD	LTE-FDD (SC-FDMA, 50% RB, 10 MHz, 64-QAM)	X	2.84	69.00	16.66	0.00	150.0	± 9.6 %
		Y	2.89	69.26	16.85		150.0	
		Z	2.81	68.97	16.58		150.0	
10159-CAD	LTE-FDD (SC-FDMA, 50% RB, 5 MHz, 64-QAM)	X	2.26	68.38	14.91	0.00	150.0	± 9.6 %
		Y	2.37	69.05	15.40		150.0	
		Z	2.21	68.17	14.68		150.0	
10160-CAC	LTE-FDD (SC-FDMA, 50% RB, 15 MHz, QPSK)	X	2.78	69.02	16.58	0.00	150.0	± 9.6 %
		Y	2.84	69.39	16.78		150.0	
		Z	2.74	68.91	16.49		150.0	
10161-CAC	LTE-FDD (SC-FDMA, 50% RB, 15 MHz, 16-QAM)	X	2.96	67.68	16.09	0.00	150.0	± 9.6 %
		Y	3.00	67.95	16.25		150.0	
		Z	2.93	67.62	16.01		150.0	
10162-CAC	LTE-FDD (SC-FDMA, 50% RB, 15 MHz, 64-QAM)	X	3.07	67.83	16.20	0.00	150.0	± 9.6 %
		Y	3.11	68.07	16.35		150.0	
		Z	3.04	67.79	16.13		150.0	
10166-CAD	LTE-FDD (SC-FDMA, 50% RB, 1.4 MHz, QPSK)	X	3.52	69.42	18.97	3.01	150.0	± 9.6 %
		Y	3.48	69.21	18.88		150.0	
		Z	3.58	69.99	19.29		150.0	
10167-CAD	LTE-FDD (SC-FDMA, 50% RB, 1.4 MHz, 16-QAM)	X	4.35	72.55	19.50	3.01	150.0	± 9.6 %
		Y	4.23	72.10	19.35		150.0	
		Z	4.57	73.71	20.03		150.0	

10168-CAD	LTE-FDD (SC-FDMA, 50% RB, 1.4 MHz, 64-QAM)	X	4.95	75.33	21.09	3.01	150.0	± 9.6 %
		Y	4.74	74.55	20.78		150.0	
		Z	5.31	76.94	21.79		150.0	
10169-CAC	LTE-FDD (SC-FDMA, 1 RB, 20 MHz, QPSK)	X	2.92	68.92	18.76	3.01	150.0	± 9.6 %
		Y	2.83	68.61	18.65		150.0	
		Z	3.02	69.75	19.20		150.0	
10170-CAC	LTE-FDD (SC-FDMA, 1 RB, 20 MHz, 16-QAM)	X	4.20	75.93	21.56	3.01	150.0	± 9.6 %
		Y	3.90	74.95	21.22		150.0	
		Z	4.73	78.44	22.61		150.0	
10171-AAC	LTE-FDD (SC-FDMA, 1 RB, 20 MHz, 64-QAM)	X	3.29	70.86	18.34	3.01	150.0	± 9.6 %
		Y	3.14	70.43	18.23		150.0	
		Z	3.53	72.31	18.98		150.0	
10172-CAC	LTE-TDD (SC-FDMA, 1 RB, 20 MHz, QPSK)	X	6.18	83.60	24.73	6.02	65.0	± 9.6 %
		Y	5.31	80.83	23.64		65.0	
		Z	5.59	82.35	24.48		65.0	
10173-CAC	LTE-TDD (SC-FDMA, 1 RB, 20 MHz, 16-QAM)	X	9.66	88.05	24.34	6.02	65.0	± 9.6 %
		Y	9.20	87.15	23.96		65.0	
		Z	11.03	90.93	25.45		65.0	
10174-CAC	LTE-TDD (SC-FDMA, 1 RB, 20 MHz, 64-QAM)	X	7.49	83.02	22.12	6.02	65.0	± 9.6 %
		Y	6.16	79.95	20.98		65.0	
		Z	7.52	83.81	22.58		65.0	
10175-CAD	LTE-FDD (SC-FDMA, 1 RB, 10 MHz, QPSK)	X	2.88	68.56	18.48	3.01	150.0	± 9.6 %
		Y	2.79	68.29	18.39		150.0	
		Z	2.97	69.36	18.91		150.0	
10176-CAD	LTE-FDD (SC-FDMA, 1 RB, 10 MHz, 16-QAM)	X	4.20	75.96	21.58	3.01	150.0	± 9.6 %
		Y	3.90	74.98	21.23		150.0	
		Z	4.74	78.47	22.62		150.0	
10177-CAF	LTE-FDD (SC-FDMA, 1 RB, 5 MHz, QPSK)	X	2.90	68.74	18.59	3.01	150.0	± 9.6 %
		Y	2.82	68.45	18.49		150.0	
		Z	3.00	69.54	19.02		150.0	
10178-CAD	LTE-FDD (SC-FDMA, 1 RB, 5 MHz, 16-QAM)	X	4.15	75.68	21.43	3.01	150.0	± 9.6 %
		Y	3.86	74.72	21.10		150.0	
		Z	4.66	78.13	22.46		150.0	
10179-CAD	LTE-FDD (SC-FDMA, 1 RB, 10 MHz, 64-QAM)	X	3.69	73.16	19.77	3.01	150.0	± 9.6 %
		Y	3.48	72.54	19.57		150.0	
		Z	4.04	75.08	20.59		150.0	
10180-CAD	LTE-FDD (SC-FDMA, 1 RB, 5 MHz, 64-QAM)	X	3.28	70.77	18.28	3.01	150.0	± 9.6 %
		Y	3.13	70.35	18.17		150.0	
		Z	3.52	72.21	18.92		150.0	
10181-CAC	LTE-FDD (SC-FDMA, 1 RB, 15 MHz, QPSK)	X	2.90	68.71	18.58	3.01	150.0	± 9.6 %
		Y	2.81	68.43	18.49		150.0	
		Z	2.99	69.52	19.01		150.0	
10182-CAC	LTE-FDD (SC-FDMA, 1 RB, 15 MHz, 16-QAM)	X	4.14	75.65	21.42	3.01	150.0	± 9.6 %
		Y	3.85	74.70	21.08		150.0	
		Z	4.65	78.10	22.45		150.0	
10183-AAB	LTE-FDD (SC-FDMA, 1 RB, 15 MHz, 64-QAM)	X	3.28	70.75	18.27	3.01	150.0	± 9.6 %
		Y	3.12	70.33	18.16		150.0	
		Z	3.51	72.19	18.91		150.0	

10184-CAD	LTE-FDD (SC-FDMA, 1 RB, 3 MHz, QPSK)	X	2.91	68.76	18.61	3.01	150.0	± 9.6 %
		Y	2.82	68.48	18.51		150.0	
		Z	3.00	69.57	19.04		150.0	
10185-CAD	LTE-FDD (SC-FDMA, 1 RB, 3 MHz, 16-QAM)	X	4.16	75.74	21.46	3.01	150.0	± 9.6 %
		Y	3.87	74.78	21.12		150.0	
		Z	4.68	78.20	22.50		150.0	
10186-AAD	LTE-FDD (SC-FDMA, 1 RB, 3 MHz, 64-QAM)	X	3.29	70.82	18.30	3.01	150.0	± 9.6 %
		Y	3.14	70.40	18.20		150.0	
		Z	3.53	72.27	18.95		150.0	
10187-CAD	LTE-FDD (SC-FDMA, 1 RB, 1.4 MHz, QPSK)	X	2.92	68.82	18.67	3.01	150.0	± 9.6 %
		Y	2.83	68.53	18.57		150.0	
		Z	3.01	69.64	19.11		150.0	
10188-CAD	LTE-FDD (SC-FDMA, 1 RB, 1.4 MHz, 16-QAM)	X	4.34	76.58	21.92	3.01	150.0	± 9.6 %
		Y	4.01	75.52	21.54		150.0	
		Z	4.92	79.24	23.02		150.0	
10189-AAD	LTE-FDD (SC-FDMA, 1 RB, 1.4 MHz, 64-QAM)	X	3.38	71.31	18.62	3.01	150.0	± 9.6 %
		Y	3.21	70.86	18.50		150.0	
		Z	3.64	72.84	19.29		150.0	
10193-CAB	IEEE 802.11n (HT Greenfield, 6.5 Mbps, BPSK)	X	4.53	66.74	16.24	0.00	150.0	± 9.6 %
		Y	4.55	66.82	16.28		150.0	
		Z	4.50	66.75	16.20		150.0	
10194-CAB	IEEE 802.11n (HT Greenfield, 39 Mbps, 16-QAM)	X	4.70	67.04	16.36	0.00	150.0	± 9.6 %
		Y	4.73	67.14	16.40		150.0	
		Z	4.67	67.04	16.32		150.0	
10195-CAB	IEEE 802.11n (HT Greenfield, 65 Mbps, 64-QAM)	X	4.74	67.07	16.38	0.00	150.0	± 9.6 %
		Y	4.77	67.16	16.42		150.0	
		Z	4.71	67.07	16.34		150.0	
10196-CAB	IEEE 802.11n (HT Mixed, 6.5 Mbps, BPSK)	X	4.53	66.80	16.25	0.00	150.0	± 9.6 %
		Y	4.56	66.89	16.30		150.0	
		Z	4.50	66.80	16.21		150.0	
10197-CAB	IEEE 802.11n (HT Mixed, 39 Mbps, 16-QAM)	X	4.71	67.06	16.37	0.00	150.0	± 9.6 %
		Y	4.74	67.16	16.41		150.0	
		Z	4.68	67.06	16.33		150.0	
10198-CAB	IEEE 802.11n (HT Mixed, 65 Mbps, 64-QAM)	X	4.74	67.09	16.39	0.00	150.0	± 9.6 %
		Y	4.77	67.18	16.43		150.0	
		Z	4.71	67.09	16.35		150.0	
10219-CAB	IEEE 802.11n (HT Mixed, 7.2 Mbps, BPSK)	X	4.48	66.81	16.22	0.00	150.0	± 9.6 %
		Y	4.51	66.91	16.27		150.0	
		Z	4.45	66.82	16.18		150.0	
10220-CAB	IEEE 802.11n (HT Mixed, 43.3 Mbps, 16-QAM)	X	4.70	67.03	16.36	0.00	150.0	± 9.6 %
		Y	4.73	67.13	16.40		150.0	
		Z	4.67	67.03	16.32		150.0	
10221-CAB	IEEE 802.11n (HT Mixed, 72.2 Mbps, 64-QAM)	X	4.75	67.02	16.37	0.00	150.0	± 9.6 %
		Y	4.78	67.11	16.41		150.0	
		Z	4.72	67.01	16.33		150.0	
10222-CAB	IEEE 802.11n (HT Mixed, 15 Mbps, BPSK)	X	5.07	67.16	16.47	0.00	150.0	± 9.6 %
		Y	5.09	67.26	16.50		150.0	
		Z	5.05	67.15	16.43		150.0	

10223-CAB	IEEE 802.11n (HT Mixed, 90 Mbps, 16-QAM)	X	5.37	67.36	16.58	0.00	150.0	± 9.6 %
		Y	5.39	67.42	16.59		150.0	
		Z	5.35	67.37	16.56		150.0	
10224-CAB	IEEE 802.11n (HT Mixed, 150 Mbps, 64-QAM)	X	5.12	67.28	16.45	0.00	150.0	± 9.6 %
		Y	5.14	67.37	16.48		150.0	
		Z	5.09	67.26	16.42		150.0	
10225-CAB	UMTS-FDD (HSPA+)	X	2.82	66.40	15.48	0.00	150.0	± 9.6 %
		Y	2.86	66.59	15.66		150.0	
		Z	2.79	66.37	15.39		150.0	
10226-CAA	LTE-TDD (SC-FDMA, 1 RB, 1.4 MHz, 16-QAM)	X	10.34	89.28	24.84	6.02	65.0	± 9.6 %
		Y	9.78	88.26	24.43		65.0	
		Z	11.95	92.40	26.02		65.0	
10227-CAA	LTE-TDD (SC-FDMA, 1 RB, 1.4 MHz, 64-QAM)	X	9.45	86.56	23.34	6.02	65.0	± 9.6 %
		Y	8.84	85.37	22.86		65.0	
		Z	10.93	89.56	24.47		65.0	
10228-CAA	LTE-TDD (SC-FDMA, 1 RB, 1.4 MHz, QPSK)	X	7.32	86.94	25.98	6.02	65.0	± 9.6 %
		Y	7.51	87.27	26.00		65.0	
		Z	7.20	87.24	26.30		65.0	
10229-CAB	LTE-TDD (SC-FDMA, 1 RB, 3 MHz, 16-QAM)	X	9.74	88.16	24.39	6.02	65.0	± 9.6 %
		Y	9.28	87.26	24.01		65.0	
		Z	11.13	91.06	25.50		65.0	
10230-CAB	LTE-TDD (SC-FDMA, 1 RB, 3 MHz, 64-QAM)	X	8.91	85.54	22.92	6.02	65.0	± 9.6 %
		Y	8.39	84.47	22.48		65.0	
		Z	10.18	88.33	24.00		65.0	
10231-CAB	LTE-TDD (SC-FDMA, 1 RB, 3 MHz, QPSK)	X	7.00	86.05	25.58	6.02	65.0	± 9.6 %
		Y	7.21	86.43	25.62		65.0	
		Z	6.88	86.32	25.89		65.0	
10232-CAC	LTE-TDD (SC-FDMA, 1 RB, 5 MHz, 16-QAM)	X	9.72	88.14	24.38	6.02	65.0	± 9.6 %
		Y	9.26	87.24	24.00		65.0	
		Z	11.11	91.04	25.49		65.0	
10233-CAC	LTE-TDD (SC-FDMA, 1 RB, 5 MHz, 64-QAM)	X	8.89	85.52	22.92	6.02	65.0	± 9.6 %
		Y	8.37	84.45	22.47		65.0	
		Z	10.16	88.31	23.99		65.0	
10234-CAC	LTE-TDD (SC-FDMA, 1 RB, 5 MHz, QPSK)	X	6.73	85.20	25.16	6.02	65.0	± 9.6 %
		Y	6.94	85.61	25.22		65.0	
		Z	6.62	85.46	25.47		65.0	
10235-CAC	LTE-TDD (SC-FDMA, 1 RB, 10 MHz, 16-QAM)	X	9.73	88.16	24.39	6.02	65.0	± 9.6 %
		Y	9.26	87.26	24.01		65.0	
		Z	11.12	91.07	25.50		65.0	
10236-CAC	LTE-TDD (SC-FDMA, 1 RB, 10 MHz, 64-QAM)	X	8.97	85.63	22.95	6.02	65.0	± 9.6 %
		Y	8.44	84.56	22.50		65.0	
		Z	10.26	88.43	24.03		65.0	
10237-CAC	LTE-TDD (SC-FDMA, 1 RB, 10 MHz, QPSK)	X	7.00	86.09	25.59	6.02	65.0	± 9.6 %
		Y	7.21	86.48	25.64		65.0	
		Z	6.88	86.35	25.91		65.0	
10238-CAC	LTE-TDD (SC-FDMA, 1 RB, 15 MHz, 16-QAM)	X	9.70	88.11	24.37	6.02	65.0	± 9.6 %
		Y	9.24	87.21	23.99		65.0	
		Z	11.08	91.01	25.48		65.0	

10239-CAC	LTE-TDD (SC-FDMA, 1 RB, 15 MHz, 64-QAM)	X	8.86	85.49	22.91	6.02	65.0	± 9.6 %
		Y	8.34	84.42	22.46		65.0	
		Z	10.12	88.27	23.98		65.0	
10240-CAC	LTE-TDD (SC-FDMA, 1 RB, 15 MHz, QPSK)	X	6.98	86.05	25.58	6.02	65.0	± 9.6 %
		Y	7.19	86.44	25.63		65.0	
		Z	6.87	86.32	25.89		65.0	
10241-CAA	LTE-TDD (SC-FDMA, 50% RB, 1.4 MHz, 16-QAM)	X	7.66	79.41	24.04	6.98	65.0	± 9.6 %
		Y	7.53	78.99	23.87		65.0	
		Z	7.72	79.98	24.35		65.0	
10242-CAA	LTE-TDD (SC-FDMA, 50% RB, 1.4 MHz, 64-QAM)	X	7.08	77.85	23.32	6.98	65.0	± 9.6 %
		Y	6.56	76.18	22.61		65.0	
		Z	6.82	77.47	23.23		65.0	
10243-CAA	LTE-TDD (SC-FDMA, 50% RB, 1.4 MHz, QPSK)	X	5.72	74.40	22.72	6.98	65.0	± 9.6 %
		Y	5.45	73.28	22.19		65.0	
		Z	5.52	73.92	22.57		65.0	
10244-CAB	LTE-TDD (SC-FDMA, 50% RB, 3 MHz, 16-QAM)	X	4.75	71.39	15.87	3.98	65.0	± 9.6 %
		Y	4.77	71.48	16.03		65.0	
		Z	4.72	71.54	15.92		65.0	
10245-CAB	LTE-TDD (SC-FDMA, 50% RB, 3 MHz, 64-QAM)	X	4.68	70.96	15.63	3.98	65.0	± 9.6 %
		Y	4.72	71.09	15.82		65.0	
		Z	4.64	71.06	15.66		65.0	
10246-CAB	LTE-TDD (SC-FDMA, 50% RB, 3 MHz, QPSK)	X	4.46	73.85	17.32	3.98	65.0	± 9.6 %
		Y	4.61	74.27	17.59		65.0	
		Z	4.17	73.10	17.00		65.0	
10247-CAC	LTE-TDD (SC-FDMA, 50% RB, 5 MHz, 16-QAM)	X	4.62	71.66	17.10	3.98	65.0	± 9.6 %
		Y	4.72	71.92	17.30		65.0	
		Z	4.41	71.11	16.82		65.0	
10248-CAC	LTE-TDD (SC-FDMA, 50% RB, 5 MHz, 64-QAM)	X	4.64	71.26	16.91	3.98	65.0	± 9.6 %
		Y	4.75	71.55	17.13		65.0	
		Z	4.42	70.71	16.63		65.0	
10249-CAC	LTE-TDD (SC-FDMA, 50% RB, 5 MHz, QPSK)	X	5.55	77.29	19.64	3.98	65.0	± 9.6 %
		Y	5.67	77.48	19.75		65.0	
		Z	5.19	76.50	19.35		65.0	
10250-CAC	LTE-TDD (SC-FDMA, 50% RB, 10 MHz, 16-QAM)	X	5.62	74.57	20.02	3.98	65.0	± 9.6 %
		Y	5.69	74.63	20.05		65.0	
		Z	5.39	73.98	19.78		65.0	
10251-CAC	LTE-TDD (SC-FDMA, 50% RB, 10 MHz, 64-QAM)	X	5.39	72.65	18.85	3.98	65.0	± 9.6 %
		Y	5.48	72.84	18.95		65.0	
		Z	5.18	72.13	18.61		65.0	
10252-CAC	LTE-TDD (SC-FDMA, 50% RB, 10 MHz, QPSK)	X	6.13	78.05	20.93	3.98	65.0	± 9.6 %
		Y	6.21	78.10	20.92		65.0	
		Z	5.78	77.32	20.70		65.0	
10253-CAC	LTE-TDD (SC-FDMA, 50% RB, 15 MHz, 16-QAM)	X	5.54	72.10	19.00	3.98	65.0	± 9.6 %
		Y	5.62	72.26	19.07		65.0	
		Z	5.35	71.63	18.79		65.0	
10254-CAC	LTE-TDD (SC-FDMA, 50% RB, 15 MHz, 64-QAM)	X	5.89	73.05	19.74	3.98	65.0	± 9.6 %
		Y	5.96	73.15	19.77		65.0	
		Z	5.69	72.56	19.53		65.0	

10255-CAC	LTE-TDD (SC-FDMA, 50% RB, 15 MHz, QPSK)	X	5.96	75.63	20.26	3.98	65.0	± 9.6 %
		Y	6.03	75.68	20.24		65.0	
		Z	5.70	75.08	20.08		65.0	
10256-CAA	LTE-TDD (SC-FDMA, 100% RB, 1.4 MHz, 16-QAM)	X	3.65	67.68	13.12	3.98	65.0	± 9.6 %
		Y	3.72	67.99	13.43		65.0	
		Z	3.58	67.63	13.06		65.0	
10257-CAA	LTE-TDD (SC-FDMA, 100% RB, 1.4 MHz, 64-QAM)	X	3.61	67.24	12.83	3.98	65.0	± 9.6 %
		Y	3.69	67.57	13.15		65.0	
		Z	3.52	67.14	12.74		65.0	
10258-CAA	LTE-TDD (SC-FDMA, 100% RB, 1.4 MHz, QPSK)	X	3.39	69.66	14.64	3.98	65.0	± 9.6 %
		Y	3.55	70.26	15.05		65.0	
		Z	3.18	68.99	14.30		65.0	
10259-CAB	LTE-TDD (SC-FDMA, 100% RB, 3 MHz, 16-QAM)	X	5.01	72.76	18.17	3.98	65.0	± 9.6 %
		Y	5.10	72.95	18.31		65.0	
		Z	4.79	72.21	17.91		65.0	
10260-CAB	LTE-TDD (SC-FDMA, 100% RB, 3 MHz, 64-QAM)	X	5.05	72.57	18.09	3.98	65.0	± 9.6 %
		Y	5.14	72.76	18.24		65.0	
		Z	4.83	72.02	17.83		65.0	
10261-CAB	LTE-TDD (SC-FDMA, 100% RB, 3 MHz, QPSK)	X	5.55	76.95	19.93	3.98	65.0	± 9.6 %
		Y	5.66	77.10	20.01		65.0	
		Z	5.23	76.20	19.66		65.0	
10262-CAC	LTE-TDD (SC-FDMA, 100% RB, 5 MHz, 16-QAM)	X	5.61	74.51	19.98	3.98	65.0	± 9.6 %
		Y	5.68	74.58	20.01		65.0	
		Z	5.37	73.92	19.73		65.0	
10263-CAC	LTE-TDD (SC-FDMA, 100% RB, 5 MHz, 64-QAM)	X	5.38	72.63	18.84	3.98	65.0	± 9.6 %
		Y	5.47	72.82	18.95		65.0	
		Z	5.17	72.10	18.61		65.0	
10264-CAC	LTE-TDD (SC-FDMA, 100% RB, 5 MHz, QPSK)	X	6.07	77.87	20.84	3.98	65.0	± 9.6 %
		Y	6.16	77.94	20.84		65.0	
		Z	5.73	77.15	20.61		65.0	
10265-CAC	LTE-TDD (SC-FDMA, 100% RB, 10 MHz, 16-QAM)	X	5.64	72.55	19.22	3.98	65.0	± 9.6 %
		Y	5.73	72.74	19.29		65.0	
		Z	5.43	72.04	19.01		65.0	
10266-CAC	LTE-TDD (SC-FDMA, 100% RB, 10 MHz, 64-QAM)	X	6.02	73.57	20.03	3.98	65.0	± 9.6 %
		Y	6.09	73.68	20.05		65.0	
		Z	5.81	73.06	19.83		65.0	
10267-CAC	LTE-TDD (SC-FDMA, 100% RB, 10 MHz, QPSK)	X	6.19	76.11	20.24	3.98	65.0	± 9.6 %
		Y	6.26	76.15	20.20		65.0	
		Z	5.92	75.57	20.08		65.0	
10268-CAC	LTE-TDD (SC-FDMA, 100% RB, 15 MHz, 16-QAM)	X	6.31	72.74	19.74	3.98	65.0	± 9.6 %
		Y	6.38	72.86	19.76		65.0	
		Z	6.11	72.28	19.56		65.0	
10269-CAC	LTE-TDD (SC-FDMA, 100% RB, 15 MHz, 64-QAM)	X	6.31	72.40	19.66	3.98	65.0	± 9.6 %
		Y	6.37	72.52	19.68		65.0	
		Z	6.11	71.95	19.47		65.0	
10270-CAC	LTE-TDD (SC-FDMA, 100% RB, 15 MHz, QPSK)	X	6.25	74.19	19.65	3.98	65.0	± 9.6 %
		Y	6.30	74.22	19.60		65.0	
		Z	6.03	73.76	19.52		65.0	

10274-CAB	UMTS-FDD (HSUPA, Subtest 5, 3GPP Rel8.10)	X	2.62	66.83	15.44	0.00	150.0	± 9.6 %
		Y	2.65	67.06	15.64		150.0	
		Z	2.60	66.81	15.36		150.0	
10275-CAB	UMTS-FDD (HSUPA, Subtest 5, 3GPP Rel8.4)	X	1.66	68.56	15.99	0.00	150.0	± 9.6 %
		Y	1.74	69.37	16.47		150.0	
		Z	1.63	68.35	15.83		150.0	
10277-CAA	PHS (QPSK)	X	2.45	61.81	7.48	9.03	50.0	± 9.6 %
		Y	2.59	62.16	7.82		50.0	
		Z	2.54	62.07	7.75		50.0	
10278-CAA	PHS (QPSK, BW 884MHz, Rolloff 0.5)	X	4.03	68.72	13.51	9.03	50.0	± 9.6 %
		Y	4.22	69.17	13.84		50.0	
		Z	4.10	68.73	13.58		50.0	
10279-CAA	PHS (QPSK, BW 884MHz, Rolloff 0.38)	X	4.13	68.96	13.67	9.03	50.0	± 9.6 %
		Y	4.33	69.41	14.00		50.0	
		Z	4.19	68.95	13.73		50.0	
10290-AAB	CDMA2000, RC1, SO55, Full Rate	X	1.59	70.25	14.71	0.00	150.0	± 9.6 %
		Y	1.82	72.15	15.78		150.0	
		Z	1.50	69.65	14.28		150.0	
10291-AAB	CDMA2000, RC3, SO55, Full Rate	X	0.90	67.12	13.22	0.00	150.0	± 9.6 %
		Y	1.00	68.73	14.25		150.0	
		Z	0.86	66.67	12.84		150.0	
10292-AAB	CDMA2000, RC3, SO32, Full Rate	X	1.36	73.82	16.65	0.00	150.0	± 9.6 %
		Y	1.71	77.26	18.32		150.0	
		Z	1.28	73.01	16.14		150.0	
10293-AAB	CDMA2000, RC3, SO3, Full Rate	X	3.29	86.77	21.89	0.00	150.0	± 9.6 %
		Y	4.71	92.66	24.11		150.0	
		Z	3.08	85.69	21.33		150.0	
10295-AAB	CDMA2000, RC1, SO3, 1/8th Rate 25 fr.	X	7.29	78.77	20.59	9.03	50.0	± 9.6 %
		Y	7.06	78.09	20.40		50.0	
		Z	7.48	78.90	20.60		50.0	
10297-AAB	LTE-FDD (SC-FDMA, 50% RB, 20 MHz, QPSK)	X	2.80	70.15	16.93	0.00	150.0	± 9.6 %
		Y	2.90	70.75	17.22		150.0	
		Z	2.76	69.98	16.83		150.0	
10298-AAC	LTE-FDD (SC-FDMA, 50% RB, 3 MHz, QPSK)	X	1.64	68.64	14.60	0.00	150.0	± 9.6 %
		Y	1.79	69.89	15.40		150.0	
		Z	1.57	68.20	14.24		150.0	
10299-AAC	LTE-FDD (SC-FDMA, 50% RB, 3 MHz, 16-QAM)	X	2.47	68.83	13.61	0.00	150.0	± 9.6 %
		Y	2.54	69.43	14.13		150.0	
		Z	2.67	69.79	13.88		150.0	
10300-AAC	LTE-FDD (SC-FDMA, 50% RB, 3 MHz, 64-QAM)	X	1.84	64.47	10.78	0.00	150.0	± 9.6 %
		Y	1.87	64.82	11.18		150.0	
		Z	1.87	64.71	10.75		150.0	
10301-AAA	IEEE 802.16e WiMAX (29:18, 5ms, 10MHz, QPSK, PUSC)	X	4.69	65.44	17.46	4.17	50.0	± 9.6 %
		Y	4.63	65.10	17.32		50.0	
		Z	4.65	65.38	17.36		50.0	
10302-AAA	IEEE 802.16e WiMAX (29:18, 5ms, 10MHz, QPSK, PUSC, 3 CTRL symbols)	X	5.12	65.81	18.03	4.96	50.0	± 9.6 %
		Y	5.16	65.97	18.16		50.0	
		Z	5.12	65.91	18.02		50.0	

10303-AAA	IEEE 802.16e WiMAX (31:15, 5ms, 10MHz, 64QAM, PUSC)	X	4.87	65.45	17.87	4.96	50.0	± 9.6 %
		Y	4.92	65.62	18.01		50.0	
		Z	4.87	65.57	17.85		50.0	
10304-AAA	IEEE 802.16e WiMAX (29:18, 5ms, 10MHz, 64QAM, PUSC)	X	4.68	65.35	17.39	4.17	50.0	± 9.6 %
		Y	4.72	65.48	17.50		50.0	
		Z	4.68	65.45	17.37		50.0	
10305-AAA	IEEE 802.16e WiMAX (31:15, 10ms, 10MHz, 64QAM, PUSC, 15 symbols)	X	4.39	67.43	19.46	6.02	35.0	± 9.6 %
		Y	4.48	67.81	19.80		35.0	
		Z	4.49	68.01	19.61		35.0	
10306-AAA	IEEE 802.16e WiMAX (29:18, 10ms, 10MHz, 64QAM, PUSC, 18 symbols)	X	4.67	66.30	18.98	6.02	35.0	± 9.6 %
		Y	4.73	66.54	19.21		35.0	
		Z	4.72	66.69	19.08		35.0	
10307-AAA	IEEE 802.16e WiMAX (29:18, 10ms, 10MHz, QPSK, PUSC, 18 symbols)	X	4.58	66.51	18.97	6.02	35.0	± 9.6 %
		Y	4.65	66.79	19.23		35.0	
		Z	4.64	66.91	19.08		35.0	
10308-AAA	IEEE 802.16e WiMAX (29:18, 10ms, 10MHz, 16QAM, PUSC)	X	4.56	66.71	19.12	6.02	35.0	± 9.6 %
		Y	4.63	67.02	19.38		35.0	
		Z	4.62	67.14	19.23		35.0	
10309-AAA	IEEE 802.16e WiMAX (29:18, 10ms, 10MHz, 16QAM, AMC 2x3, 18 symbols)	X	4.72	66.48	19.11	6.02	35.0	± 9.6 %
		Y	4.79	66.75	19.35		35.0	
		Z	4.77	66.86	19.21		35.0	
10310-AAA	IEEE 802.16e WiMAX (29:18, 10ms, 10MHz, QPSK, AMC 2x3, 18 symbols)	X	4.62	66.39	18.97	6.02	35.0	± 9.6 %
		Y	4.69	66.63	19.20		35.0	
		Z	4.68	66.79	19.08		35.0	
10311-AAB	LTE-FDD (SC-FDMA, 100% RB, 15 MHz, QPSK)	X	3.17	69.43	16.56	0.00	150.0	± 9.6 %
		Y	3.28	70.00	16.83		150.0	
		Z	3.13	69.27	16.47		150.0	
10313-AAA	iDEN 1:3	X	3.04	69.90	14.46	6.99	70.0	± 9.6 %
		Y	3.00	69.58	14.26		70.0	
		Z	2.91	69.76	14.60		70.0	
10314-AAA	iDEN 1:6	X	4.05	75.03	19.23	10.00	30.0	± 9.6 %
		Y	3.94	74.12	18.73		30.0	
		Z	4.12	75.22	19.44		30.0	
10315-AAB	IEEE 802.11b WiFi 2.4 GHz (DSSS, 1 Mbps, 96pc duty cycle)	X	1.10	63.97	15.35	0.17	150.0	± 9.6 %
		Y	1.11	64.32	15.62		150.0	
		Z	1.09	63.83	15.22		150.0	
10316-AAB	IEEE 802.11g WiFi 2.4 GHz (ERP-OFDM, 6 Mbps, 96pc duty cycle)	X	4.56	66.66	16.26	0.17	150.0	± 9.6 %
		Y	4.58	66.74	16.29		150.0	
		Z	4.53	66.67	16.22		150.0	
10317-AAB	IEEE 802.11a WiFi 5 GHz (OFDM, 6 Mbps, 96pc duty cycle)	X	4.56	66.66	16.26	0.17	150.0	± 9.6 %
		Y	4.58	66.74	16.29		150.0	
		Z	4.53	66.67	16.22		150.0	
10400-AAC	IEEE 802.11ac WiFi (20MHz, 64-QAM, 99pc duty cycle)	X	4.68	67.08	16.34	0.00	150.0	± 9.6 %
		Y	4.72	67.18	16.39		150.0	
		Z	4.65	67.07	16.30		150.0	
10401-AAC	IEEE 802.11ac WiFi (40MHz, 64-QAM, 99pc duty cycle)	X	5.39	67.23	16.48	0.00	150.0	± 9.6 %
		Y	5.40	67.28	16.50		150.0	
		Z	5.35	67.18	16.43		150.0	

10402-AAC	IEEE 802.11ac WiFi (80MHz, 64-QAM, 99pc duty cycle)	X	5.64	67.54	16.50	0.00	150.0	± 9.6 %
		Y	5.66	67.64	16.53		150.0	
		Z	5.61	67.52	16.47		150.0	
10403-AAB	CDMA2000 (1xEV-DO, Rev. 0)	X	1.59	70.25	14.71	0.00	115.0	± 9.6 %
		Y	1.82	72.15	15.78		115.0	
		Z	1.50	69.65	14.28		115.0	
10404-AAB	CDMA2000 (1xEV-DO, Rev. A)	X	1.59	70.25	14.71	0.00	115.0	± 9.6 %
		Y	1.82	72.15	15.78		115.0	
		Z	1.50	69.65	14.28		115.0	
10406-AAB	CDMA2000, RC3, SO32, SCH0, Full Rate	X	100.00	119.40	29.12	0.00	100.0	± 9.6 %
		Y	100.00	122.00	30.20		100.0	
		Z	100.00	117.27	28.11		100.0	
10410-AAB	LTE-TDD (SC-FDMA, 1 RB, 10 MHz, QPSK, UL Subframe=2,3,4,7,8,9)	X	7.12	84.42	19.31	3.23	80.0	± 9.6 %
		Y	6.26	82.81	18.74		80.0	
		Z	11.96	91.59	21.64		80.0	
10415-AAA	IEEE 802.11b WiFi 2.4 GHz (DSSS, 1 Mbps, 99pc duty cycle)	X	1.03	63.32	14.96	0.00	150.0	± 9.6 %
		Y	1.04	63.68	15.26		150.0	
		Z	1.03	63.25	14.86		150.0	
10416-AAA	IEEE 802.11g WiFi 2.4 GHz (ERP-OFDM, 6 Mbps, 99pc duty cycle)	X	4.53	66.77	16.30	0.00	150.0	± 9.6 %
		Y	4.56	66.86	16.35		150.0	
		Z	4.51	66.78	16.27		150.0	
10417-AAA	IEEE 802.11a/h WiFi 5 GHz (OFDM, 6 Mbps, 99pc duty cycle)	X	4.53	66.77	16.30	0.00	150.0	± 9.6 %
		Y	4.56	66.86	16.35		150.0	
		Z	4.51	66.78	16.27		150.0	
10418-AAA	IEEE 802.11g WiFi 2.4 GHz (DSSS-OFDM, 6 Mbps, 99pc duty cycle, Long preamble)	X	4.52	66.95	16.33	0.00	150.0	± 9.6 %
		Y	4.55	67.03	16.37		150.0	
		Z	4.50	66.95	16.30		150.0	
10419-AAA	IEEE 802.11g WiFi 2.4 GHz (DSSS-OFDM, 6 Mbps, 99pc duty cycle, Short preamble)	X	4.54	66.89	16.33	0.00	150.0	± 9.6 %
		Y	4.57	66.97	16.37		150.0	
		Z	4.52	66.90	16.30		150.0	
10422-AAA	IEEE 802.11n (HT Greenfield, 7.2 Mbps, BPSK)	X	4.66	66.88	16.34	0.00	150.0	± 9.6 %
		Y	4.68	66.96	16.38		150.0	
		Z	4.63	66.88	16.30		150.0	
10423-AAA	IEEE 802.11n (HT Greenfield, 43.3 Mbps, 16-QAM)	X	4.82	67.18	16.45	0.00	150.0	± 9.6 %
		Y	4.85	67.27	16.49		150.0	
		Z	4.78	67.18	16.41		150.0	
10424-AAA	IEEE 802.11n (HT Greenfield, 72.2 Mbps, 64-QAM)	X	4.74	67.14	16.42	0.00	150.0	± 9.6 %
		Y	4.77	67.23	16.47		150.0	
		Z	4.71	67.13	16.39		150.0	
10425-AAA	IEEE 802.11n (HT Greenfield, 15 Mbps, BPSK)	X	5.34	67.39	16.57	0.00	150.0	± 9.6 %
		Y	5.35	67.47	16.59		150.0	
		Z	5.30	67.36	16.53		150.0	
10426-AAA	IEEE 802.11n (HT Greenfield, 90 Mbps, 16-QAM)	X	5.35	67.44	16.59	0.00	150.0	± 9.6 %
		Y	5.36	67.49	16.60		150.0	
		Z	5.32	67.42	16.56		150.0	

10427-AAA	IEEE 802.11n (HT Greenfield, 150 Mbps, 64-QAM)	X	5.36	67.40	16.57	0.00	150.0	± 9.6 %
		Y	5.37	67.48	16.59		150.0	
		Z	5.32	67.37	16.53		150.0	
10430-AAA	LTE-FDD (OFDMA, 5 MHz, E-TM 3.1)	X	4.43	71.93	18.75	0.00	150.0	± 9.6 %
		Y	4.42	71.71	18.69		150.0	
		Z	4.43	72.11	18.76		150.0	
10431-AAA	LTE-FDD (OFDMA, 10 MHz, E-TM 3.1)	X	4.21	67.37	16.31	0.00	150.0	± 9.6 %
		Y	4.25	67.48	16.39		150.0	
		Z	4.17	67.37	16.26		150.0	
10432-AAA	LTE-FDD (OFDMA, 15 MHz, E-TM 3.1)	X	4.51	67.21	16.38	0.00	150.0	± 9.6 %
		Y	4.54	67.31	16.43		150.0	
		Z	4.47	67.21	16.34		150.0	
10433-AAA	LTE-FDD (OFDMA, 20 MHz, E-TM 3.1)	X	4.75	67.17	16.44	0.00	150.0	± 9.6 %
		Y	4.79	67.27	16.49		150.0	
		Z	4.72	67.17	16.41		150.0	
10434-AAA	W-CDMA (BS Test Model 1, 64 DPCH)	X	4.61	73.06	18.81	0.00	150.0	± 9.6 %
		Y	4.59	72.83	18.78		150.0	
		Z	4.61	73.27	18.81		150.0	
10435-AAB	LTE-TDD (SC-FDMA, 1 RB, 20 MHz, QPSK, UL Subframe=2,3,4,7,8,9)	X	6.74	83.64	19.02	3.23	80.0	± 9.6 %
		Y	5.96	82.09	18.46		80.0	
		Z	10.99	90.40	21.25		80.0	
10447-AAA	LTE-FDD (OFDMA, 5 MHz, E-TM 3.1, Clipping 44%)	X	3.51	67.45	15.64	0.00	150.0	± 9.6 %
		Y	3.57	67.65	15.82		150.0	
		Z	3.46	67.42	15.53		150.0	
10448-AAA	LTE-FDD (OFDMA, 10 MHz, E-TM 3.1, Clipping 44%)	X	4.05	67.16	16.18	0.00	150.0	± 9.6 %
		Y	4.09	67.27	16.26		150.0	
		Z	4.02	67.16	16.13		150.0	
10449-AAA	LTE-FDD (OFDMA, 15 MHz, E-TM 3.1, Clipping 44%)	X	4.33	67.05	16.28	0.00	150.0	± 9.6 %
		Y	4.36	67.15	16.34		150.0	
		Z	4.30	67.04	16.24		150.0	
10450-AAA	LTE-FDD (OFDMA, 20 MHz, E-TM 3.1, Clipping 44%)	X	4.52	66.95	16.30	0.00	150.0	± 9.6 %
		Y	4.55	67.05	16.35		150.0	
		Z	4.50	66.95	16.27		150.0	
10451-AAA	W-CDMA (BS Test Model 1, 64 DPCH, Clipping 44%)	X	3.39	67.63	15.23	0.00	150.0	± 9.6 %
		Y	3.47	67.90	15.48		150.0	
		Z	3.34	67.55	15.09		150.0	
10456-AAA	IEEE 802.11ac WiFi (160MHz, 64-QAM, 99pc duty cycle)	X	6.21	67.93	16.72	0.00	150.0	± 9.6 %
		Y	6.21	67.99	16.72		150.0	
		Z	6.19	67.92	16.69		150.0	
10457-AAA	UMTS-FDD (DC-HSDPA)	X	3.80	65.42	16.01	0.00	150.0	± 9.6 %
		Y	3.81	65.50	16.06		150.0	
		Z	3.79	65.44	15.98		150.0	
10458-AAA	CDMA2000 (1xEV-DO, Rev. B, 2 carriers)	X	3.19	66.85	14.54	0.00	150.0	± 9.6 %
		Y	3.28	67.17	14.85		150.0	
		Z	3.13	66.73	14.35		150.0	
10459-AAA	CDMA2000 (1xEV-DO, Rev. B, 3 carriers)	X	4.26	65.09	15.50	0.00	150.0	± 9.6 %
		Y	4.45	65.72	15.90		150.0	
		Z	4.15	64.82	15.27		150.0	

10460-AAA	UMTS-FDD (WCDMA, AMR)	X	0.95	69.24	16.88	0.00	150.0	± 9.6 %
		Y	1.02	70.79	17.77		150.0	
		Z	0.93	68.79	16.59		150.0	
10461-AAA	LTE-TDD (SC-FDMA, 1 RB, 1.4 MHz, QPSK, UL Subframe=2,3,4,7,8,9)	X	3.16	76.40	17.59	3.29	80.0	± 9.6 %
		Y	3.00	75.64	17.23		80.0	
		Z	4.60	82.00	19.74		80.0	
10462-AAA	LTE-TDD (SC-FDMA, 1 RB, 1.4 MHz, 16-QAM, UL Subframe=2,3,4,7,8,9)	X	0.95	60.00	7.73	3.23	80.0	± 9.6 %
		Y	0.93	60.00	7.68		80.0	
		Z	0.93	60.16	7.81		80.0	
10463-AAA	LTE-TDD (SC-FDMA, 1 RB, 1.4 MHz, 64-QAM, UL Subframe=2,3,4,7,8,9)	X	0.96	60.00	7.25	3.23	80.0	± 9.6 %
		Y	0.96	60.00	7.20		80.0	
		Z	0.93	60.00	7.22		80.0	
10464-AAA	LTE-TDD (SC-FDMA, 1 RB, 3 MHz, QPSK, UL Subframe=2,3,4,7,8,9)	X	2.40	72.59	15.64	3.23	80.0	± 9.6 %
		Y	2.28	71.93	15.30		80.0	
		Z	3.30	77.16	17.51		80.0	
10465-AAA	LTE-TDD (SC-FDMA, 1 RB, 3 MHz, 16-QAM, UL Subframe=2,3,4,7,8,9)	X	0.94	60.00	7.67	3.23	80.0	± 9.6 %
		Y	0.93	60.00	7.61		80.0	
		Z	0.91	60.00	7.66		80.0	
10466-AAA	LTE-TDD (SC-FDMA, 1 RB, 3 MHz, 64-QAM, UL Subframe=2,3,4,7,8,9)	X	0.97	60.00	7.21	3.23	80.0	± 9.6 %
		Y	0.96	60.00	7.15		80.0	
		Z	0.93	60.00	7.18		80.0	
10467-AAB	LTE-TDD (SC-FDMA, 1 RB, 5 MHz, QPSK, UL Subframe=2,3,4,7,8,9)	X	2.51	73.23	15.91	3.23	80.0	± 9.6 %
		Y	2.39	72.52	15.56		80.0	
		Z	3.54	78.13	17.88		80.0	
10468-AAB	LTE-TDD (SC-FDMA, 1 RB, 5 MHz, 16-QAM, UL Subframe=2,3,4,7,8,9)	X	0.94	60.00	7.68	3.23	80.0	± 9.6 %
		Y	0.93	60.00	7.62		80.0	
		Z	0.91	60.00	7.68		80.0	
10469-AAB	LTE-TDD (SC-FDMA, 1 RB, 5 MHz, 64-QAM, UL Subframe=2,3,4,7,8,9)	X	0.97	60.00	7.20	3.23	80.0	± 9.6 %
		Y	0.96	60.00	7.15		80.0	
		Z	0.93	60.00	7.18		80.0	
10470-AAB	LTE-TDD (SC-FDMA, 1 RB, 10 MHz, QPSK, UL Subframe=2,3,4,7,8,9)	X	2.50	73.21	15.89	3.23	80.0	± 9.6 %
		Y	2.37	72.50	15.54		80.0	
		Z	3.54	78.12	17.87		80.0	
10471-AAB	LTE-TDD (SC-FDMA, 1 RB, 10 MHz, 16-QAM, UL Subframe=2,3,4,7,8,9)	X	0.94	60.00	7.67	3.23	80.0	± 9.6 %
		Y	0.93	60.00	7.61		80.0	
		Z	0.91	60.00	7.66		80.0	
10472-AAB	LTE-TDD (SC-FDMA, 1 RB, 10 MHz, 64-QAM, UL Subframe=2,3,4,7,8,9)	X	0.96	60.00	7.19	3.23	80.0	± 9.6 %
		Y	0.96	60.00	7.14		80.0	
		Z	0.93	60.00	7.16		80.0	
10473-AAB	LTE-TDD (SC-FDMA, 1 RB, 15 MHz, QPSK, UL Subframe=2,3,4,7,8,9)	X	2.50	73.17	15.87	3.23	80.0	± 9.6 %
		Y	2.37	72.47	15.52		80.0	
		Z	3.52	78.07	17.84		80.0	
10474-AAB	LTE-TDD (SC-FDMA, 1 RB, 15 MHz, 16-QAM, UL Subframe=2,3,4,7,8,9)	X	0.94	60.00	7.67	3.23	80.0	± 9.6 %
		Y	0.93	60.00	7.61		80.0	
		Z	0.91	60.00	7.66		80.0	
10475-AAB	LTE-TDD (SC-FDMA, 1 RB, 15 MHz, 64-QAM, UL Subframe=2,3,4,7,8,9)	X	0.96	60.00	7.19	3.23	80.0	± 9.6 %
		Y	0.95	60.00	7.14		80.0	
		Z	0.93	60.00	7.16		80.0	

10477-AAB	LTE-TDD (SC-FDMA, 1 RB, 20 MHz, 16-QAM, UL Subframe=2,3,4,7,8,9)	X	0.94	60.00	7.65	3.23	80.0	± 9.6 %
		Y	0.93	60.00	7.59		80.0	
		Z	0.91	60.00	7.64		80.0	
10478-AAB	LTE-TDD (SC-FDMA, 1 RB, 20 MHz, 64-QAM, UL Subframe=2,3,4,7,8,9)	X	0.96	60.00	7.18	3.23	80.0	± 9.6 %
		Y	0.96	60.00	7.13		80.0	
		Z	0.93	60.00	7.15		80.0	
10479-AAA	LTE-TDD (SC-FDMA, 50% RB, 1.4 MHz, QPSK, UL Subframe=2,3,4,7,8,9)	X	3.82	75.02	18.32	3.23	80.0	± 9.6 %
		Y	3.62	74.21	18.05		80.0	
		Z	4.46	77.72	19.42		80.0	
10480-AAA	LTE-TDD (SC-FDMA, 50% RB, 1.4 MHz, 16-QAM, UL Subframe=2,3,4,7,8,9)	X	3.25	69.58	14.47	3.23	80.0	± 9.6 %
		Y	3.17	69.32	14.47		80.0	
		Z	3.70	71.50	15.22		80.0	
10481-AAA	LTE-TDD (SC-FDMA, 50% RB, 1.4 MHz, 64-QAM, UL Subframe=2,3,4,7,8,9)	X	2.76	67.27	13.16	3.23	80.0	± 9.6 %
		Y	2.74	67.18	13.23		80.0	
		Z	3.01	68.58	13.68		80.0	
10482-AAA	LTE-TDD (SC-FDMA, 50% RB, 3 MHz, QPSK, UL Subframe=2,3,4,7,8,9)	X	2.20	67.37	14.31	2.23	80.0	± 9.6 %
		Y	2.35	68.14	14.78		80.0	
		Z	2.08	66.84	14.02		80.0	
10483-AAA	LTE-TDD (SC-FDMA, 50% RB, 3 MHz, 16-QAM, UL Subframe=2,3,4,7,8,9)	X	2.64	66.33	13.17	2.23	80.0	± 9.6 %
		Y	2.72	66.71	13.49		80.0	
		Z	2.71	66.89	13.39		80.0	
10484-AAA	LTE-TDD (SC-FDMA, 50% RB, 3 MHz, 64-QAM, UL Subframe=2,3,4,7,8,9)	X	2.59	65.86	12.96	2.23	80.0	± 9.6 %
		Y	2.68	66.27	13.30		80.0	
		Z	2.63	66.32	13.14		80.0	
10485-AAB	LTE-TDD (SC-FDMA, 50% RB, 5 MHz, QPSK, UL Subframe=2,3,4,7,8,9)	X	2.65	69.52	16.23	2.23	80.0	± 9.6 %
		Y	2.77	70.09	16.54		80.0	
		Z	2.52	69.04	16.02		80.0	
10486-AAB	LTE-TDD (SC-FDMA, 50% RB, 5 MHz, 16-QAM, UL Subframe=2,3,4,7,8,9)	X	2.73	66.83	14.56	2.23	80.0	± 9.6 %
		Y	2.83	67.27	14.87		80.0	
		Z	2.62	66.49	14.35		80.0	
10487-AAB	LTE-TDD (SC-FDMA, 50% RB, 5 MHz, 64-QAM, UL Subframe=2,3,4,7,8,9)	X	2.75	66.57	14.44	2.23	80.0	± 9.6 %
		Y	2.85	67.00	14.75		80.0	
		Z	2.64	66.24	14.22		80.0	
10488-AAB	LTE-TDD (SC-FDMA, 50% RB, 10 MHz, QPSK, UL Subframe=2,3,4,7,8,9)	X	3.11	69.87	17.17	2.23	80.0	± 9.6 %
		Y	3.21	70.31	17.35		80.0	
		Z	2.98	69.45	17.00		80.0	
10489-AAB	LTE-TDD (SC-FDMA, 50% RB, 10 MHz, 16-QAM, UL Subframe=2,3,4,7,8,9)	X	3.21	67.51	16.20	2.23	80.0	± 9.6 %
		Y	3.27	67.74	16.32		80.0	
		Z	3.12	67.26	16.07		80.0	
10490-AAB	LTE-TDD (SC-FDMA, 50% RB, 10 MHz, 64-QAM, UL Subframe=2,3,4,7,8,9)	X	3.31	67.44	16.19	2.23	80.0	± 9.6 %
		Y	3.37	67.66	16.31		80.0	
		Z	3.22	67.20	16.06		80.0	
10491-AAB	LTE-TDD (SC-FDMA, 50% RB, 15 MHz, QPSK, UL Subframe=2,3,4,7,8,9)	X	3.45	69.12	17.04	2.23	80.0	± 9.6 %
		Y	3.54	69.47	17.16		80.0	
		Z	3.34	68.78	16.91		80.0	
10492-AAB	LTE-TDD (SC-FDMA, 50% RB, 15 MHz, 16-QAM, UL Subframe=2,3,4,7,8,9)	X	3.61	67.20	16.42	2.23	80.0	± 9.6 %
		Y	3.67	67.39	16.51		80.0	
		Z	3.53	66.97	16.31		80.0	

10493-AAB	LTE-TDD (SC-FDMA, 50% RB, 15 MHz, 64-QAM, UL Subframe=2,3,4,7,8,9)	X	3.68	67.13	16.41	2.23	80.0	± 9.6 %
		Y	3.74	67.31	16.49		80.0	
		Z	3.60	66.91	16.30		80.0	
10494-AAB	LTE-TDD (SC-FDMA, 50% RB, 20 MHz, QPSK, UL Subframe=2,3,4,7,8,9)	X	3.65	70.25	17.36	2.23	80.0	± 9.6 %
		Y	3.77	70.66	17.50		80.0	
		Z	3.52	69.86	17.23		80.0	
10495-AAB	LTE-TDD (SC-FDMA, 50% RB, 20 MHz, 16-QAM, UL Subframe=2,3,4,7,8,9)	X	3.63	67.51	16.59	2.23	80.0	± 9.6 %
		Y	3.69	67.72	16.68		80.0	
		Z	3.55	67.26	16.48		80.0	
10496-AAB	LTE-TDD (SC-FDMA, 50% RB, 20 MHz, 64-QAM, UL Subframe=2,3,4,7,8,9)	X	3.72	67.34	16.57	2.23	80.0	± 9.6 %
		Y	3.78	67.53	16.64		80.0	
		Z	3.64	67.11	16.46		80.0	
10497-AAA	LTE-TDD (SC-FDMA, 100% RB, 1.4 MHz, QPSK, UL Subframe=2,3,4,7,8,9)	X	1.59	63.52	11.51	2.23	80.0	± 9.6 %
		Y	1.71	64.33	12.09		80.0	
		Z	1.49	63.03	11.17		80.0	
10498-AAA	LTE-TDD (SC-FDMA, 100% RB, 1.4 MHz, 16-QAM, UL Subframe=2,3,4,7,8,9)	X	1.40	60.13	8.74	2.23	80.0	± 9.6 %
		Y	1.50	60.76	9.30		80.0	
		Z	1.35	60.00	8.54		80.0	
10499-AAA	LTE-TDD (SC-FDMA, 100% RB, 1.4 MHz, 64-QAM, UL Subframe=2,3,4,7,8,9)	X	1.40	60.00	8.54	2.23	80.0	± 9.6 %
		Y	1.47	60.38	8.96		80.0	
		Z	1.37	60.00	8.41		80.0	
10500-AAA	LTE-TDD (SC-FDMA, 100% RB, 3 MHz, QPSK, UL Subframe=2,3,4,7,8,9)	X	2.81	69.52	16.57	2.23	80.0	± 9.6 %
		Y	2.92	70.00	16.81		80.0	
		Z	2.69	69.09	16.38		80.0	
10501-AAA	LTE-TDD (SC-FDMA, 100% RB, 3 MHz, 16-QAM, UL Subframe=2,3,4,7,8,9)	X	2.95	67.23	15.25	2.23	80.0	± 9.6 %
		Y	3.03	67.55	15.48		80.0	
		Z	2.85	66.94	15.08		80.0	
10502-AAA	LTE-TDD (SC-FDMA, 100% RB, 3 MHz, 64-QAM, UL Subframe=2,3,4,7,8,9)	X	3.01	67.14	15.16	2.23	80.0	± 9.6 %
		Y	3.09	67.47	15.39		80.0	
		Z	2.91	66.86	14.98		80.0	
10503-AAB	LTE-TDD (SC-FDMA, 100% RB, 5 MHz, QPSK, UL Subframe=2,3,4,7,8,9)	X	3.07	69.70	17.08	2.23	80.0	± 9.6 %
		Y	3.18	70.14	17.26		80.0	
		Z	2.95	69.28	16.91		80.0	
10504-AAB	LTE-TDD (SC-FDMA, 100% RB, 5 MHz, 16-QAM, UL Subframe=2,3,4,7,8,9)	X	3.19	67.42	16.14	2.23	80.0	± 9.6 %
		Y	3.25	67.66	16.27		80.0	
		Z	3.11	67.17	16.01		80.0	
10505-AAB	LTE-TDD (SC-FDMA, 100% RB, 5 MHz, 64-QAM, UL Subframe=2,3,4,7,8,9)	X	3.29	67.35	16.13	2.23	80.0	± 9.6 %
		Y	3.35	67.57	16.26		80.0	
		Z	3.20	67.11	16.00		80.0	
10506-AAB	LTE-TDD (SC-FDMA, 100% RB, 10 MHz, QPSK, UL Subframe=2,3,4,7,8,9)	X	3.63	70.12	17.29	2.23	80.0	± 9.6 %
		Y	3.74	70.54	17.44		80.0	
		Z	3.50	69.73	17.16		80.0	
10507-AAB	LTE-TDD (SC-FDMA, 100% RB, 10 MHz, 16-QAM, UL Subframe=2,3,4,7,8,9)	X	3.62	67.45	16.55	2.23	80.0	± 9.6 %
		Y	3.67	67.66	16.64		80.0	
		Z	3.53	67.20	16.44		80.0	

10508-AAB	LTE-TDD (SC-FDMA, 100% RB, 10 MHz, 64-QAM, UL Subframe=2,3,4,7,8,9)	X	3.71	67.28	16.52	2.23	80.0	± 9.6 %
		Y	3.77	67.47	16.60		80.0	
		Z	3.63	67.04	16.41		80.0	
10509-AAB	LTE-TDD (SC-FDMA, 100% RB, 15 MHz, QPSK, UL Subframe=2,3,4,7,8,9)	X	4.06	69.48	17.08	2.23	80.0	± 9.6 %
		Y	4.15	69.80	17.17		80.0	
		Z	3.94	69.18	16.98		80.0	
10510-AAB	LTE-TDD (SC-FDMA, 100% RB, 15 MHz, 16-QAM, UL Subframe=2,3,4,7,8,9)	X	4.13	67.43	16.69	2.23	80.0	± 9.6 %
		Y	4.18	67.63	16.75		80.0	
		Z	4.04	67.20	16.59		80.0	
10511-AAB	LTE-TDD (SC-FDMA, 100% RB, 15 MHz, 64-QAM, UL Subframe=2,3,4,7,8,9)	X	4.20	67.25	16.66	2.23	80.0	± 9.6 %
		Y	4.25	67.43	16.72		80.0	
		Z	4.11	67.04	16.57		80.0	
10512-AAB	LTE-TDD (SC-FDMA, 100% RB, 20 MHz, QPSK, UL Subframe=2,3,4,7,8,9)	X	4.13	70.56	17.37	2.23	80.0	± 9.6 %
		Y	4.25	70.98	17.50		80.0	
		Z	4.00	70.21	17.25		80.0	
10513-AAB	LTE-TDD (SC-FDMA, 100% RB, 20 MHz, 16-QAM, UL Subframe=2,3,4,7,8,9)	X	4.00	67.59	16.74	2.23	80.0	± 9.6 %
		Y	4.06	67.82	16.82		80.0	
		Z	3.91	67.34	16.64		80.0	
10514-AAB	LTE-TDD (SC-FDMA, 100% RB, 20 MHz, 64-QAM, UL Subframe=2,3,4,7,8,9)	X	4.05	67.28	16.67	2.23	80.0	± 9.6 %
		Y	4.10	67.48	16.74		80.0	
		Z	3.96	67.05	16.57		80.0	
10515-AAA	IEEE 802.11b WiFi 2.4 GHz (DSSS, 2 Mbps, 99pc duty cycle)	X	0.99	63.52	15.04	0.00	150.0	± 9.6 %
		Y	1.00	63.92	15.36		150.0	
		Z	0.99	63.44	14.93		150.0	
10516-AAA	IEEE 802.11b WiFi 2.4 GHz (DSSS, 5.5 Mbps, 99pc duty cycle)	X	0.65	71.87	18.40	0.00	150.0	± 9.6 %
		Y	0.77	75.38	20.23		150.0	
		Z	0.62	70.84	17.85		150.0	
10517-AAA	IEEE 802.11b WiFi 2.4 GHz (DSSS, 11 Mbps, 99pc duty cycle)	X	0.85	65.63	15.82	0.00	150.0	± 9.6 %
		Y	0.87	66.42	16.38		150.0	
		Z	0.84	65.40	15.63		150.0	
10518-AAA	IEEE 802.11a/h WiFi 5 GHz (OFDM, 9 Mbps, 99pc duty cycle)	X	4.52	66.86	16.29	0.00	150.0	± 9.6 %
		Y	4.55	66.94	16.33		150.0	
		Z	4.50	66.86	16.25		150.0	
10519-AAA	IEEE 802.11a/h WiFi 5 GHz (OFDM, 12 Mbps, 99pc duty cycle)	X	4.70	67.07	16.39	0.00	150.0	± 9.6 %
		Y	4.73	67.16	16.44		150.0	
		Z	4.67	67.07	16.35		150.0	
10520-AAA	IEEE 802.11a/h WiFi 5 GHz (OFDM, 18 Mbps, 99pc duty cycle)	X	4.55	67.03	16.32	0.00	150.0	± 9.6 %
		Y	4.59	67.14	16.37		150.0	
		Z	4.52	67.02	16.28		150.0	
10521-AAA	IEEE 802.11a/h WiFi 5 GHz (OFDM, 24 Mbps, 99pc duty cycle)	X	4.49	67.03	16.31	0.00	150.0	± 9.6 %
		Y	4.52	67.14	16.36		150.0	
		Z	4.46	67.02	16.27		150.0	
10522-AAA	IEEE 802.11a/h WiFi 5 GHz (OFDM, 36 Mbps, 99pc duty cycle)	X	4.55	67.14	16.40	0.00	150.0	± 9.6 %
		Y	4.58	67.23	16.45		150.0	
		Z	4.52	67.13	16.36		150.0	

10523-AAA	IEEE 802.11a/h WiFi 5 GHz (OFDM, 48 Mbps, 99pc duty cycle)	X	4.44	67.02	16.26	0.00	150.0	± 9.6 %
		Y	4.47	67.12	16.31		150.0	
		Z	4.41	67.03	16.23		150.0	
10524-AAA	IEEE 802.11a/h WiFi 5 GHz (OFDM, 54 Mbps, 99pc duty cycle)	X	4.49	67.05	16.37	0.00	150.0	± 9.6 %
		Y	4.52	67.14	16.41		150.0	
		Z	4.46	67.05	16.33		150.0	
10525-AAA	IEEE 802.11ac WiFi (20MHz, MCS0, 99pc duty cycle)	X	4.49	66.12	15.97	0.00	150.0	± 9.6 %
		Y	4.51	66.21	16.02		150.0	
		Z	4.46	66.13	15.94		150.0	
10526-AAA	IEEE 802.11ac WiFi (20MHz, MCS1, 99pc duty cycle)	X	4.65	66.47	16.11	0.00	150.0	± 9.6 %
		Y	4.68	66.57	16.15		150.0	
		Z	4.62	66.46	16.07		150.0	
10527-AAA	IEEE 802.11ac WiFi (20MHz, MCS2, 99pc duty cycle)	X	4.57	66.44	16.05	0.00	150.0	± 9.6 %
		Y	4.61	66.54	16.10		150.0	
		Z	4.54	66.43	16.01		150.0	
10528-AAA	IEEE 802.11ac WiFi (20MHz, MCS3, 99pc duty cycle)	X	4.59	66.45	16.08	0.00	150.0	± 9.6 %
		Y	4.62	66.56	16.13		150.0	
		Z	4.56	66.44	16.04		150.0	
10529-AAA	IEEE 802.11ac WiFi (20MHz, MCS4, 99pc duty cycle)	X	4.59	66.45	16.08	0.00	150.0	± 9.6 %
		Y	4.62	66.56	16.13		150.0	
		Z	4.56	66.44	16.04		150.0	
10531-AAA	IEEE 802.11ac WiFi (20MHz, MCS6, 99pc duty cycle)	X	4.57	66.54	16.09	0.00	150.0	± 9.6 %
		Y	4.61	66.66	16.15		150.0	
		Z	4.54	66.52	16.05		150.0	
10532-AAA	IEEE 802.11ac WiFi (20MHz, MCS7, 99pc duty cycle)	X	4.44	66.40	16.03	0.00	150.0	± 9.6 %
		Y	4.47	66.53	16.09		150.0	
		Z	4.41	66.38	15.98		150.0	
10533-AAA	IEEE 802.11ac WiFi (20MHz, MCS8, 99pc duty cycle)	X	4.60	66.51	16.08	0.00	150.0	± 9.6 %
		Y	4.63	66.61	16.13		150.0	
		Z	4.57	66.51	16.04		150.0	
10534-AAA	IEEE 802.11ac WiFi (40MHz, MCS0, 99pc duty cycle)	X	5.12	66.51	16.12	0.00	150.0	± 9.6 %
		Y	5.14	66.61	16.16		150.0	
		Z	5.10	66.50	16.09		150.0	
10535-AAA	IEEE 802.11ac WiFi (40MHz, MCS1, 99pc duty cycle)	X	5.19	66.69	16.20	0.00	150.0	± 9.6 %
		Y	5.21	66.78	16.23		150.0	
		Z	5.16	66.67	16.17		150.0	
10536-AAA	IEEE 802.11ac WiFi (40MHz, MCS2, 99pc duty cycle)	X	5.06	66.65	16.16	0.00	150.0	± 9.6 %
		Y	5.08	66.75	16.20		150.0	
		Z	5.03	66.64	16.13		150.0	
10537-AAA	IEEE 802.11ac WiFi (40MHz, MCS3, 99pc duty cycle)	X	5.12	66.61	16.15	0.00	150.0	± 9.6 %
		Y	5.14	66.71	16.18		150.0	
		Z	5.09	66.59	16.11		150.0	
10538-AAA	IEEE 802.11ac WiFi (40MHz, MCS4, 99pc duty cycle)	X	5.20	66.61	16.19	0.00	150.0	± 9.6 %
		Y	5.23	66.72	16.22		150.0	
		Z	5.17	66.59	16.15		150.0	
10540-AAA	IEEE 802.11ac WiFi (40MHz, MCS6, 99pc duty cycle)	X	5.13	66.62	16.21	0.00	150.0	± 9.6 %
		Y	5.16	66.73	16.24		150.0	
		Z	5.10	66.59	16.16		150.0	

10541-AAA	IEEE 802.11ac WiFi (40MHz, MCS7, 99pc duty cycle)	X	5.11	66.51	16.14	0.00	150.0	± 9.6 %
		Y	5.13	66.61	16.18		150.0	
		Z	5.08	66.49	16.10		150.0	
10542-AAA	IEEE 802.11ac WiFi (40MHz, MCS8, 99pc duty cycle)	X	5.26	66.57	16.19	0.00	150.0	± 9.6 %
		Y	5.29	66.67	16.22		150.0	
		Z	5.23	66.56	16.15		150.0	
10543-AAA	IEEE 802.11ac WiFi (40MHz, MCS9, 99pc duty cycle)	X	5.33	66.59	16.22	0.00	150.0	± 9.6 %
		Y	5.36	66.69	16.25		150.0	
		Z	5.30	66.57	16.18		150.0	
10544-AAA	IEEE 802.11ac WiFi (80MHz, MCS0, 99pc duty cycle)	X	5.44	66.62	16.11	0.00	150.0	± 9.6 %
		Y	5.45	66.72	16.14		150.0	
		Z	5.42	66.60	16.08		150.0	
10545-AAA	IEEE 802.11ac WiFi (80MHz, MCS1, 99pc duty cycle)	X	5.62	67.02	16.26	0.00	150.0	± 9.6 %
		Y	5.64	67.09	16.28		150.0	
		Z	5.59	66.99	16.23		150.0	
10546-AAA	IEEE 802.11ac WiFi (80MHz, MCS2, 99pc duty cycle)	X	5.50	66.80	16.17	0.00	150.0	± 9.6 %
		Y	5.52	66.92	16.21		150.0	
		Z	5.47	66.77	16.13		150.0	
10547-AAA	IEEE 802.11ac WiFi (80MHz, MCS3, 99pc duty cycle)	X	5.57	66.85	16.18	0.00	150.0	± 9.6 %
		Y	5.59	66.95	16.21		150.0	
		Z	5.54	66.82	16.15		150.0	
10548-AAA	IEEE 802.11ac WiFi (80MHz, MCS4, 99pc duty cycle)	X	5.78	67.66	16.56	0.00	150.0	± 9.6 %
		Y	5.79	67.74	16.58		150.0	
		Z	5.73	67.57	16.50		150.0	
10550-AAA	IEEE 802.11ac WiFi (80MHz, MCS6, 99pc duty cycle)	X	5.53	66.84	16.20	0.00	150.0	± 9.6 %
		Y	5.54	66.93	16.22		150.0	
		Z	5.50	66.82	16.17		150.0	
10551-AAA	IEEE 802.11ac WiFi (80MHz, MCS7, 99pc duty cycle)	X	5.53	66.87	16.18	0.00	150.0	± 9.6 %
		Y	5.55	66.98	16.21		150.0	
		Z	5.50	66.83	16.13		150.0	
10552-AAA	IEEE 802.11ac WiFi (80MHz, MCS8, 99pc duty cycle)	X	5.45	66.69	16.10	0.00	150.0	± 9.6 %
		Y	5.47	66.80	16.13		150.0	
		Z	5.43	66.69	16.07		150.0	
10553-AAA	IEEE 802.11ac WiFi (80MHz, MCS9, 99pc duty cycle)	X	5.53	66.71	16.13	0.00	150.0	± 9.6 %
		Y	5.55	66.82	16.17		150.0	
		Z	5.50	66.69	16.10		150.0	
10554-AAA	IEEE 1602.11ac WiFi (160MHz, MCS0, 99pc duty cycle)	X	5.85	66.97	16.19	0.00	150.0	± 9.6 %
		Y	5.86	67.06	16.22		150.0	
		Z	5.83	66.95	16.16		150.0	
10555-AAA	IEEE 1602.11ac WiFi (160MHz, MCS1, 99pc duty cycle)	X	5.97	67.25	16.31	0.00	150.0	± 9.6 %
		Y	5.98	67.34	16.33		150.0	
		Z	5.94	67.22	16.27		150.0	
10556-AAA	IEEE 1602.11ac WiFi (160MHz, MCS2, 99pc duty cycle)	X	5.99	67.30	16.33	0.00	150.0	± 9.6 %
		Y	6.00	67.39	16.35		150.0	
		Z	5.96	67.27	16.29		150.0	
10557-AAA	IEEE 1602.11ac WiFi (160MHz, MCS3, 99pc duty cycle)	X	5.95	67.20	16.30	0.00	150.0	± 9.6 %
		Y	5.97	67.30	16.33		150.0	
		Z	5.93	67.17	16.26		150.0	

10558-AAA	IEEE 1602.11ac WiFi (160MHz, MCS4, 99pc duty cycle)	X	6.00	67.35	16.39	0.00	150.0	± 9.6 %
		Y	6.01	67.46	16.42		150.0	
		Z	5.97	67.32	16.35		150.0	
10560-AAA	IEEE 1602.11ac WiFi (160MHz, MCS6, 99pc duty cycle)	X	6.00	67.21	16.36	0.00	150.0	± 9.6 %
		Y	6.01	67.32	16.39		150.0	
		Z	5.97	67.18	16.32		150.0	
10561-AAA	IEEE 1602.11ac WiFi (160MHz, MCS7, 99pc duty cycle)	X	5.92	67.18	16.38	0.00	150.0	± 9.6 %
		Y	5.93	67.28	16.40		150.0	
		Z	5.89	67.15	16.34		150.0	
10562-AAA	IEEE 1602.11ac WiFi (160MHz, MCS8, 99pc duty cycle)	X	6.03	67.51	16.54	0.00	150.0	± 9.6 %
		Y	6.05	67.63	16.58		150.0	
		Z	5.99	67.45	16.49		150.0	
10563-AAA	IEEE 1602.11ac WiFi (160MHz, MCS9, 99pc duty cycle)	X	6.16	67.54	16.51	0.00	150.0	± 9.6 %
		Y	6.24	67.80	16.62		150.0	
		Z	6.09	67.38	16.42		150.0	
10564-AAA	IEEE 802.11g WiFi 2.4 GHz (DSSS-OFDM, 9 Mbps, 99pc duty cycle)	X	4.84	66.87	16.39	0.46	150.0	± 9.6 %
		Y	4.86	66.95	16.43		150.0	
		Z	4.81	66.87	16.35		150.0	
10565-AAA	IEEE 802.11g WiFi 2.4 GHz (DSSS-OFDM, 12 Mbps, 99pc duty cycle)	X	5.06	67.32	16.72	0.46	150.0	± 9.6 %
		Y	5.09	67.40	16.76		150.0	
		Z	5.03	67.32	16.69		150.0	
10566-AAA	IEEE 802.11g WiFi 2.4 GHz (DSSS-OFDM, 18 Mbps, 99pc duty cycle)	X	4.90	67.15	16.53	0.46	150.0	± 9.6 %
		Y	4.93	67.25	16.57		150.0	
		Z	4.86	67.14	16.49		150.0	
10567-AAA	IEEE 802.11g WiFi 2.4 GHz (DSSS-OFDM, 24 Mbps, 99pc duty cycle)	X	4.93	67.58	16.91	0.46	150.0	± 9.6 %
		Y	4.96	67.66	16.94		150.0	
		Z	4.90	67.58	16.88		150.0	
10568-AAA	IEEE 802.11g WiFi 2.4 GHz (DSSS-OFDM, 36 Mbps, 99pc duty cycle)	X	4.80	66.88	16.26	0.46	150.0	± 9.6 %
		Y	4.83	66.98	16.31		150.0	
		Z	4.77	66.87	16.22		150.0	
10569-AAA	IEEE 802.11g WiFi 2.4 GHz (DSSS-OFDM, 48 Mbps, 99pc duty cycle)	X	4.89	67.70	16.99	0.46	150.0	± 9.6 %
		Y	4.92	67.76	17.00		150.0	
		Z	4.87	67.71	16.96		150.0	
10570-AAA	IEEE 802.11g WiFi 2.4 GHz (DSSS-OFDM, 54 Mbps, 99pc duty cycle)	X	4.92	67.54	16.91	0.46	150.0	± 9.6 %
		Y	4.95	67.61	16.94		150.0	
		Z	4.89	67.54	16.89		150.0	
10571-AAA	IEEE 802.11b WiFi 2.4 GHz (DSSS, 1 Mbps, 90pc duty cycle)	X	1.16	64.28	15.41	0.46	130.0	± 9.6 %
		Y	1.17	64.64	15.67		130.0	
		Z	1.15	64.08	15.27		130.0	
10572-AAA	IEEE 802.11b WiFi 2.4 GHz (DSSS, 2 Mbps, 90pc duty cycle)	X	1.18	64.84	15.77	0.46	130.0	± 9.6 %
		Y	1.19	65.22	16.04		130.0	
		Z	1.16	64.62	15.61		130.0	
10573-AAA	IEEE 802.11b WiFi 2.4 GHz (DSSS, 5.5 Mbps, 90pc duty cycle)	X	1.62	81.69	21.81	0.46	130.0	± 9.6 %
		Y	2.21	87.31	23.95		130.0	
		Z	1.35	78.93	20.83		130.0	
10574-AAA	IEEE 802.11b WiFi 2.4 GHz (DSSS, 11 Mbps, 90pc duty cycle)	X	1.28	70.51	18.69	0.46	130.0	± 9.6 %
		Y	1.33	71.36	19.17		130.0	
		Z	1.24	69.92	18.40		130.0	

10575-AAA	IEEE 802.11g WiFi 2.4 GHz (DSSS-OFDM, 6 Mbps, 90pc duty cycle)	X	4.60	66.56	16.34	0.46	130.0	± 9.6 %
		Y	4.63	66.64	16.38		130.0	
		Z	4.58	66.57	16.31		130.0	
10576-AAA	IEEE 802.11g WiFi 2.4 GHz (DSSS-OFDM, 9 Mbps, 90pc duty cycle)	X	4.63	66.74	16.42	0.46	130.0	± 9.6 %
		Y	4.65	66.81	16.45		130.0	
		Z	4.61	66.75	16.39		130.0	
10577-AAA	IEEE 802.11g WiFi 2.4 GHz (DSSS-OFDM, 12 Mbps, 90pc duty cycle)	X	4.82	67.02	16.59	0.46	130.0	± 9.6 %
		Y	4.85	67.10	16.62		130.0	
		Z	4.79	67.02	16.55		130.0	
10578-AAA	IEEE 802.11g WiFi 2.4 GHz (DSSS-OFDM, 18 Mbps, 90pc duty cycle)	X	4.73	67.20	16.71	0.46	130.0	± 9.6 %
		Y	4.75	67.27	16.73		130.0	
		Z	4.70	67.20	16.68		130.0	
10579-AAA	IEEE 802.11g WiFi 2.4 GHz (DSSS-OFDM, 24 Mbps, 90pc duty cycle)	X	4.48	66.39	15.95	0.46	130.0	± 9.6 %
		Y	4.51	66.51	16.01		130.0	
		Z	4.45	66.37	15.90		130.0	
10580-AAA	IEEE 802.11g WiFi 2.4 GHz (DSSS-OFDM, 36 Mbps, 90pc duty cycle)	X	4.52	66.43	15.97	0.46	130.0	± 9.6 %
		Y	4.55	66.54	16.03		130.0	
		Z	4.49	66.42	15.93		130.0	
10581-AAA	IEEE 802.11g WiFi 2.4 GHz (DSSS-OFDM, 48 Mbps, 90pc duty cycle)	X	4.62	67.23	16.64	0.46	130.0	± 9.6 %
		Y	4.65	67.31	16.67		130.0	
		Z	4.60	67.23	16.61		130.0	
10582-AAA	IEEE 802.11g WiFi 2.4 GHz (DSSS-OFDM, 54 Mbps, 90pc duty cycle)	X	4.41	66.13	15.72	0.46	130.0	± 9.6 %
		Y	4.45	66.25	15.79		130.0	
		Z	4.38	66.11	15.67		130.0	
10583-AAA	IEEE 802.11a/h WiFi 5 GHz (OFDM, 6 Mbps, 90pc duty cycle)	X	4.60	66.56	16.34	0.46	130.0	± 9.6 %
		Y	4.63	66.64	16.38		130.0	
		Z	4.58	66.57	16.31		130.0	
10584-AAA	IEEE 802.11a/h WiFi 5 GHz (OFDM, 9 Mbps, 90pc duty cycle)	X	4.63	66.74	16.42	0.46	130.0	± 9.6 %
		Y	4.65	66.81	16.45		130.0	
		Z	4.61	66.75	16.39		130.0	
10585-AAA	IEEE 802.11a/h WiFi 5 GHz (OFDM, 12 Mbps, 90pc duty cycle)	X	4.82	67.02	16.59	0.46	130.0	± 9.6 %
		Y	4.85	67.10	16.62		130.0	
		Z	4.79	67.02	16.55		130.0	
10586-AAA	IEEE 802.11a/h WiFi 5 GHz (OFDM, 18 Mbps, 90pc duty cycle)	X	4.73	67.20	16.71	0.46	130.0	± 9.6 %
		Y	4.75	67.27	16.73		130.0	
		Z	4.70	67.20	16.68		130.0	
10587-AAA	IEEE 802.11a/h WiFi 5 GHz (OFDM, 24 Mbps, 90pc duty cycle)	X	4.48	66.39	15.95	0.46	130.0	± 9.6 %
		Y	4.51	66.51	16.01		130.0	
		Z	4.45	66.37	15.90		130.0	
10588-AAA	IEEE 802.11a/h WiFi 5 GHz (OFDM, 36 Mbps, 90pc duty cycle)	X	4.52	66.43	15.97	0.46	130.0	± 9.6 %
		Y	4.55	66.54	16.03		130.0	
		Z	4.49	66.42	15.93		130.0	
10589-AAA	IEEE 802.11a/h WiFi 5 GHz (OFDM, 48 Mbps, 90pc duty cycle)	X	4.62	67.23	16.64	0.46	130.0	± 9.6 %
		Y	4.65	67.31	16.67		130.0	
		Z	4.60	67.23	16.61		130.0	
10590-AAA	IEEE 802.11a/h WiFi 5 GHz (OFDM, 54 Mbps, 90pc duty cycle)	X	4.41	66.13	15.72	0.46	130.0	± 9.6 %
		Y	4.45	66.25	15.79		130.0	
		Z	4.38	66.11	15.67		130.0	

10591-AAA	IEEE 802.11n (HT Mixed, 20MHz, MCS0, 90pc duty cycle)	X	4.76	66.64	16.46	0.46	130.0	± 9.6 %
		Y	4.78	66.70	16.48		130.0	
		Z	4.73	66.65	16.43		130.0	
10592-AAA	IEEE 802.11n (HT Mixed, 20MHz, MCS1, 90pc duty cycle)	X	4.90	66.97	16.59	0.46	130.0	± 9.6 %
		Y	4.93	67.04	16.61		130.0	
		Z	4.87	66.97	16.56		130.0	
10593-AAA	IEEE 802.11n (HT Mixed, 20MHz, MCS2, 90pc duty cycle)	X	4.82	66.86	16.45	0.46	130.0	± 9.6 %
		Y	4.85	66.94	16.49		130.0	
		Z	4.79	66.85	16.42		130.0	
10594-AAA	IEEE 802.11n (HT Mixed, 20MHz, MCS3, 90pc duty cycle)	X	4.88	67.04	16.62	0.46	130.0	± 9.6 %
		Y	4.90	67.11	16.65		130.0	
		Z	4.85	67.04	16.59		130.0	
10595-AAA	IEEE 802.11n (HT Mixed, 20MHz, MCS4, 90pc duty cycle)	X	4.84	66.98	16.51	0.46	130.0	± 9.6 %
		Y	4.87	67.06	16.54		130.0	
		Z	4.81	66.98	16.48		130.0	
10596-AAA	IEEE 802.11n (HT Mixed, 20MHz, MCS5, 90pc duty cycle)	X	4.78	66.97	16.51	0.46	130.0	± 9.6 %
		Y	4.81	67.05	16.54		130.0	
		Z	4.75	66.96	16.47		130.0	
10597-AAA	IEEE 802.11n (HT Mixed, 20MHz, MCS6, 90pc duty cycle)	X	4.73	66.86	16.38	0.46	130.0	± 9.6 %
		Y	4.76	66.95	16.42		130.0	
		Z	4.69	66.85	16.34		130.0	
10598-AAA	IEEE 802.11n (HT Mixed, 20MHz, MCS7, 90pc duty cycle)	X	4.71	67.12	16.66	0.46	130.0	± 9.6 %
		Y	4.74	67.20	16.70		130.0	
		Z	4.69	67.11	16.63		130.0	
10599-AAA	IEEE 802.11n (HT Mixed, 40MHz, MCS0, 90pc duty cycle)	X	5.42	67.13	16.65	0.46	130.0	± 9.6 %
		Y	5.44	67.22	16.67		130.0	
		Z	5.39	67.11	16.62		130.0	
10600-AAA	IEEE 802.11n (HT Mixed, 40MHz, MCS1, 90pc duty cycle)	X	5.54	67.51	16.81	0.46	130.0	± 9.6 %
		Y	5.55	67.54	16.80		130.0	
		Z	5.50	67.46	16.76		130.0	
10601-AAA	IEEE 802.11n (HT Mixed, 40MHz, MCS2, 90pc duty cycle)	X	5.44	67.29	16.72	0.46	130.0	± 9.6 %
		Y	5.45	67.35	16.73		130.0	
		Z	5.40	67.27	16.68		130.0	
10602-AAA	IEEE 802.11n (HT Mixed, 40MHz, MCS3, 90pc duty cycle)	X	5.54	67.36	16.67	0.46	130.0	± 9.6 %
		Y	5.55	67.38	16.66		130.0	
		Z	5.52	67.38	16.65		130.0	
10603-AAA	IEEE 802.11n (HT Mixed, 40MHz, MCS4, 90pc duty cycle)	X	5.61	67.63	16.94	0.46	130.0	± 9.6 %
		Y	5.62	67.67	16.94		130.0	
		Z	5.58	67.64	16.92		130.0	
10604-AAA	IEEE 802.11n (HT Mixed, 40MHz, MCS5, 90pc duty cycle)	X	5.46	67.22	16.72	0.46	130.0	± 9.6 %
		Y	5.45	67.21	16.69		130.0	
		Z	5.45	67.27	16.72		130.0	
10605-AAA	IEEE 802.11n (HT Mixed, 40MHz, MCS6, 90pc duty cycle)	X	5.53	67.42	16.82	0.46	130.0	± 9.6 %
		Y	5.54	67.45	16.81		130.0	
		Z	5.50	67.41	16.78		130.0	
10606-AAA	IEEE 802.11n (HT Mixed, 40MHz, MCS7, 90pc duty cycle)	X	5.27	66.74	16.33	0.46	130.0	± 9.6 %
		Y	5.30	66.85	16.37		130.0	
		Z	5.24	66.71	16.29		130.0	

10607-AAA	IEEE 802.11ac WiFi (20MHz, MCS0, 90pc duty cycle)	X	4.60	65.96	16.09	0.46	130.0	± 9.6 %
		Y	4.62	66.04	16.12		130.0	
		Z	4.57	65.98	16.06		130.0	
10608-AAA	IEEE 802.11ac WiFi (20MHz, MCS1, 90pc duty cycle)	X	4.77	66.35	16.25	0.46	130.0	± 9.6 %
		Y	4.80	66.43	16.28		130.0	
		Z	4.74	66.36	16.22		130.0	
10609-AAA	IEEE 802.11ac WiFi (20MHz, MCS2, 90pc duty cycle)	X	4.66	66.18	16.07	0.46	130.0	± 9.6 %
		Y	4.69	66.28	16.12		130.0	
		Z	4.63	66.18	16.04		130.0	
10610-AAA	IEEE 802.11ac WiFi (20MHz, MCS3, 90pc duty cycle)	X	4.71	66.35	16.24	0.46	130.0	± 9.6 %
		Y	4.74	66.44	16.28		130.0	
		Z	4.68	66.36	16.21		130.0	
10611-AAA	IEEE 802.11ac WiFi (20MHz, MCS4, 90pc duty cycle)	X	4.63	66.15	16.08	0.46	130.0	± 9.6 %
		Y	4.66	66.24	16.12		130.0	
		Z	4.60	66.15	16.05		130.0	
10612-AAA	IEEE 802.11ac WiFi (20MHz, MCS5, 90pc duty cycle)	X	4.63	66.27	16.11	0.46	130.0	± 9.6 %
		Y	4.66	66.38	16.15		130.0	
		Z	4.59	66.27	16.08		130.0	
10613-AAA	IEEE 802.11ac WiFi (20MHz, MCS6, 90pc duty cycle)	X	4.63	66.15	15.99	0.46	130.0	± 9.6 %
		Y	4.66	66.26	16.04		130.0	
		Z	4.59	66.13	15.95		130.0	
10614-AAA	IEEE 802.11ac WiFi (20MHz, MCS7, 90pc duty cycle)	X	4.58	66.38	16.25	0.46	130.0	± 9.6 %
		Y	4.61	66.48	16.29		130.0	
		Z	4.56	66.37	16.22		130.0	
10615-AAA	IEEE 802.11ac WiFi (20MHz, MCS8, 90pc duty cycle)	X	4.62	65.95	15.84	0.46	130.0	± 9.6 %
		Y	4.65	66.05	15.89		130.0	
		Z	4.59	65.95	15.80		130.0	
10616-AAA	IEEE 802.11ac WiFi (40MHz, MCS0, 90pc duty cycle)	X	5.24	66.41	16.28	0.46	130.0	± 9.6 %
		Y	5.26	66.49	16.30		130.0	
		Z	5.21	66.40	16.25		130.0	
10617-AAA	IEEE 802.11ac WiFi (40MHz, MCS1, 90pc duty cycle)	X	5.31	66.58	16.34	0.46	130.0	± 9.6 %
		Y	5.32	66.64	16.34		130.0	
		Z	5.28	66.57	16.31		130.0	
10618-AAA	IEEE 802.11ac WiFi (40MHz, MCS2, 90pc duty cycle)	X	5.20	66.60	16.36	0.46	130.0	± 9.6 %
		Y	5.21	66.67	16.38		130.0	
		Z	5.17	66.60	16.34		130.0	
10619-AAA	IEEE 802.11ac WiFi (40MHz, MCS3, 90pc duty cycle)	X	5.20	66.38	16.18	0.46	130.0	± 9.6 %
		Y	5.22	66.46	16.20		130.0	
		Z	5.18	66.37	16.15		130.0	
10620-AAA	IEEE 802.11ac WiFi (40MHz, MCS4, 90pc duty cycle)	X	5.29	66.42	16.25	0.46	130.0	± 9.6 %
		Y	5.31	66.50	16.28		130.0	
		Z	5.26	66.40	16.22		130.0	
10621-AAA	IEEE 802.11ac WiFi (40MHz, MCS5, 90pc duty cycle)	X	5.31	66.59	16.47	0.46	130.0	± 9.6 %
		Y	5.32	66.66	16.47		130.0	
		Z	5.28	66.59	16.44		130.0	
10622-AAA	IEEE 802.11ac WiFi (40MHz, MCS6, 90pc duty cycle)	X	5.31	66.74	16.53	0.46	130.0	± 9.6 %
		Y	5.33	66.80	16.54		130.0	
		Z	5.29	66.75	16.51		130.0	

10623-AAA	IEEE 802.11ac WiFi (40MHz, MCS7, 90pc duty cycle)	X	5.19	66.24	16.15	0.46	130.0	± 9.6 %
		Y	5.21	66.33	16.17		130.0	
		Z	5.16	66.23	16.11		130.0	
10624-AAA	IEEE 802.11ac WiFi (40MHz, MCS8, 90pc duty cycle)	X	5.38	66.45	16.32	0.46	130.0	± 9.6 %
		Y	5.40	66.52	16.33		130.0	
		Z	5.35	66.44	16.29		130.0	
10625-AAA	IEEE 802.11ac WiFi (40MHz, MCS9, 90pc duty cycle)	X	5.69	67.26	16.78	0.46	130.0	± 9.6 %
		Y	5.73	67.39	16.82		130.0	
		Z	5.62	67.15	16.69		130.0	
10626-AAA	IEEE 802.11ac WiFi (80MHz, MCS0, 90pc duty cycle)	X	5.54	66.47	16.24	0.46	130.0	± 9.6 %
		Y	5.55	66.55	16.25		130.0	
		Z	5.52	66.47	16.21		130.0	
10627-AAA	IEEE 802.11ac WiFi (80MHz, MCS1, 90pc duty cycle)	X	5.77	67.01	16.47	0.46	130.0	± 9.6 %
		Y	5.77	67.06	16.46		130.0	
		Z	5.74	66.99	16.44		130.0	
10628-AAA	IEEE 802.11ac WiFi (80MHz, MCS2, 90pc duty cycle)	X	5.56	66.51	16.15	0.46	130.0	± 9.6 %
		Y	5.58	66.61	16.18		130.0	
		Z	5.53	66.48	16.12		130.0	
10629-AAA	IEEE 802.11ac WiFi (80MHz, MCS3, 90pc duty cycle)	X	5.63	66.57	16.17	0.46	130.0	± 9.6 %
		Y	5.65	66.66	16.19		130.0	
		Z	5.61	66.55	16.14		130.0	
10630-AAA	IEEE 802.11ac WiFi (80MHz, MCS4, 90pc duty cycle)	X	6.00	67.86	16.82	0.46	130.0	± 9.6 %
		Y	6.01	67.93	16.83		130.0	
		Z	5.94	67.73	16.73		130.0	
10631-AAA	IEEE 802.11ac WiFi (80MHz, MCS5, 90pc duty cycle)	X	5.95	67.83	17.01	0.46	130.0	± 9.6 %
		Y	5.97	67.92	17.02		130.0	
		Z	5.91	67.77	16.96		130.0	
10632-AAA	IEEE 802.11ac WiFi (80MHz, MCS6, 90pc duty cycle)	X	5.75	67.12	16.67	0.46	130.0	± 9.6 %
		Y	5.75	67.15	16.65		130.0	
		Z	5.73	67.12	16.65		130.0	
10633-AAA	IEEE 802.11ac WiFi (80MHz, MCS7, 90pc duty cycle)	X	5.63	66.72	16.29	0.46	130.0	± 9.6 %
		Y	5.65	66.81	16.31		130.0	
		Z	5.61	66.70	16.26		130.0	
10634-AAA	IEEE 802.11ac WiFi (80MHz, MCS8, 90pc duty cycle)	X	5.62	66.75	16.37	0.46	130.0	± 9.6 %
		Y	5.64	66.85	16.39		130.0	
		Z	5.59	66.74	16.34		130.0	
10635-AAA	IEEE 802.11ac WiFi (80MHz, MCS9, 90pc duty cycle)	X	5.48	66.01	15.71	0.46	130.0	± 9.6 %
		Y	5.51	66.14	15.76		130.0	
		Z	5.45	65.98	15.67		130.0	
10636-AAA	IEEE 1602.11ac WiFi (160MHz, MCS0, 90pc duty cycle)	X	5.96	66.83	16.32	0.46	130.0	± 9.6 %
		Y	5.96	66.90	16.33		130.0	
		Z	5.94	66.82	16.30		130.0	
10637-AAA	IEEE 1602.11ac WiFi (160MHz, MCS1, 90pc duty cycle)	X	6.11	67.19	16.49	0.46	130.0	± 9.6 %
		Y	6.11	67.25	16.49		130.0	
		Z	6.08	67.17	16.46		130.0	
10638-AAA	IEEE 1602.11ac WiFi (160MHz, MCS2, 90pc duty cycle)	X	6.11	67.17	16.45	0.46	130.0	± 9.6 %
		Y	6.11	67.25	16.46		130.0	
		Z	6.08	67.16	16.42		130.0	

10639-AAA	IEEE 1602.11ac WiFi (160MHz, MCS3, 90pc duty cycle)	X	6.08	67.12	16.47	0.46	130.0	± 9.6 %
		Y	6.09	67.20	16.48		130.0	
		Z	6.06	67.10	16.44		130.0	
10640-AAA	IEEE 1602.11ac WiFi (160MHz, MCS4, 90pc duty cycle)	X	6.08	67.10	16.40	0.46	130.0	± 9.6 %
		Y	6.09	67.19	16.42		130.0	
		Z	6.05	67.07	16.36		130.0	
10641-AAA	IEEE 1602.11ac WiFi (160MHz, MCS5, 90pc duty cycle)	X	6.13	67.03	16.39	0.46	130.0	± 9.6 %
		Y	6.13	67.10	16.39		130.0	
		Z	6.11	67.02	16.36		130.0	
10642-AAA	IEEE 1602.11ac WiFi (160MHz, MCS6, 90pc duty cycle)	X	6.18	67.31	16.70	0.46	130.0	± 9.6 %
		Y	6.19	67.39	16.71		130.0	
		Z	6.15	67.29	16.67		130.0	
10643-AAA	IEEE 1602.11ac WiFi (160MHz, MCS7, 90pc duty cycle)	X	6.01	66.96	16.42	0.46	130.0	± 9.6 %
		Y	6.01	67.04	16.43		130.0	
		Z	5.98	66.94	16.38		130.0	
10644-AAA	IEEE 1602.11ac WiFi (160MHz, MCS8, 90pc duty cycle)	X	6.14	67.38	16.65	0.46	130.0	± 9.6 %
		Y	6.16	67.50	16.68		130.0	
		Z	6.11	67.32	16.59		130.0	
10645-AAA	IEEE 1602.11ac WiFi (160MHz, MCS9, 90pc duty cycle)	X	6.34	67.58	16.70	0.46	130.0	± 9.6 %
		Y	6.43	67.90	16.84		130.0	
		Z	6.25	67.39	16.59		130.0	
10646-AAC	LTE-TDD (SC-FDMA, 1 RB, 5 MHz, QPSK, UL Subframe=2,7)	X	12.03	96.53	31.61	9.30	60.0	± 9.6 %
		Y	13.68	98.80	32.22		60.0	
		Z	11.35	95.67	31.51		60.0	
10647-AAB	LTE-TDD (SC-FDMA, 1 RB, 20 MHz, QPSK, UL Subframe=2,7)	X	10.87	95.02	31.23	9.30	60.0	± 9.6 %
		Y	12.42	97.44	31.90		60.0	
		Z	10.19	94.02	31.08		60.0	
10648-AAA	CDMA2000 (1x Advanced)	X	0.71	64.17	11.16	0.00	150.0	± 9.6 %
		Y	0.76	65.11	11.91		150.0	
		Z	0.68	63.86	10.84		150.0	

^E Uncertainty is determined using the max. deviation from linear response applying rectangular distribution and is expressed for the square of the field value.



Accredited by the Swiss Accreditation Service (SAS)
The Swiss Accreditation Service is one of the signatories to the EA
Multilateral Agreement for the recognition of calibration certificates

Accreditation No.: **SCS 0108**

Client **PC Test**

Certificate No: **ES3-3332_Aug17**

CALIBRATION CERTIFICATE

Object **ES3DV3 - SN:3332**

Calibration procedure(s) **QA CAL-01.v9, QA CAL-23.v5, QA CAL-25.v6
Calibration procedure for dosimetric E-field probes**

Calibration date: **August 14, 2017**

This calibration certificate documents the traceability to national standards, which realize the physical units of measurements (SI).
The measurements and the uncertainties with confidence probability are given on the following pages and are part of the certificate.

All calibrations have been conducted in the closed laboratory facility: environment temperature (22 ± 3)°C and humidity < 70%.

Calibration Equipment used (M&TE critical for calibration)

PHY
8/27/17

Primary Standards	ID	Cal Date (Certificate No.)	Scheduled Calibration
Power meter NRP	SN: 104778	04-Apr-17 (No. 217-02521/02522)	Apr-18
Power sensor NRP-Z91	SN: 103244	04-Apr-17 (No. 217-02521)	Apr-18
Power sensor NRP-Z91	SN: 103245	04-Apr-17 (No. 217-02525)	Apr-18
Reference 20 dB Attenuator	SN: S5277 (20x)	07-Apr-17 (No. 217-02528)	Apr-18
Reference Probe ES3DV2	SN: 3013	31-Dec-16 (No. ES3-3013_Dec16)	Dec-17
DAE4	SN: 660	7-Dec-16 (No. DAE4-660_Dec16)	Dec-17
Secondary Standards	ID	Check Date (in house)	Scheduled Check
Power meter E4419B	SN: GB41293874	06-Apr-16 (in house check Jun-16)	In house check: Jun-18
Power sensor E4412A	SN: MY41498087	06-Apr-16 (in house check Jun-16)	In house check: Jun-18
Power sensor E4412A	SN: 000110210	06-Apr-16 (in house check Jun-16)	In house check: Jun-18
RF generator HP 8648C	SN: US3642U01700	04-Aug-99 (in house check Jun-16)	In house check: Jun-18
Network Analyzer HP 8753E	SN: US37390585	18-Oct-01 (in house check Oct-16)	In house check: Oct-17

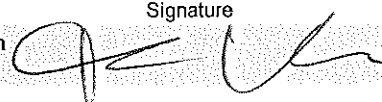
Calibrated by: **Jeton Kastrati** (Name) **Laboratory Technician** (Function)  (Signature)

Approved by: **Katja Pokovic** (Name) **Technical Manager** (Function)  (Signature)

Issued: August 16, 2017

This calibration certificate shall not be reproduced except in full without written approval of the laboratory.



Accredited by the Swiss Accreditation Service (SAS)

Accreditation No.: **SCS 0108**

The Swiss Accreditation Service is one of the signatories to the EA
Multilateral Agreement for the recognition of calibration certificates

Glossary:

TSL	tissue simulating liquid
NORM _{x,y,z}	sensitivity in free space
ConvF	sensitivity in TSL / NORM _{x,y,z}
DCP	diode compression point
CF	crest factor (1/duty_cycle) of the RF signal
A, B, C, D	modulation dependent linearization parameters
Polarization φ	φ rotation around probe axis
Polarization ϑ	ϑ rotation around an axis that is in the plane normal to probe axis (at measurement center), i.e., $\vartheta = 0$ is normal to probe axis
Connector Angle	information used in DASY system to align probe sensor X to the robot coordinate system

Calibration is Performed According to the Following Standards:

- IEEE Std 1528-2013, "IEEE Recommended Practice for Determining the Peak Spatial-Averaged Specific Absorption Rate (SAR) in the Human Head from Wireless Communications Devices: Measurement Techniques", June 2013
- IEC 62209-1, "Measurement procedure for the assessment of Specific Absorption Rate (SAR) from hand-held and body-mounted devices used next to the ear (frequency range of 300 MHz to 6 GHz)", July 2016
- IEC 62209-2, "Procedure to determine the Specific Absorption Rate (SAR) for wireless communication devices used in close proximity to the human body (frequency range of 30 MHz to 6 GHz)", March 2010
- KDB 865664, "SAR Measurement Requirements for 100 MHz to 6 GHz"

Methods Applied and Interpretation of Parameters:

- NORM_{x,y,z}**: Assessed for E-field polarization $\vartheta = 0$ ($f \leq 900$ MHz in TEM-cell; $f > 1800$ MHz: R22 waveguide). NORM_{x,y,z} are only intermediate values, i.e., the uncertainties of NORM_{x,y,z} does not affect the E²-field uncertainty inside TSL (see below ConvF).
- NORM(f)_{x,y,z}** = NORM_{x,y,z} * frequency_response (see Frequency Response Chart). This linearization is implemented in DASY4 software versions later than 4.2. The uncertainty of the frequency response is included in the stated uncertainty of ConvF.
- DCP_{x,y,z}**: DCP are numerical linearization parameters assessed based on the data of power sweep with CW signal (no uncertainty required). DCP does not depend on frequency nor media.
- PAR**: PAR is the Peak to Average Ratio that is not calibrated but determined based on the signal characteristics
- A_{x,y,z}; B_{x,y,z}; C_{x,y,z}; D_{x,y,z}; VR_{x,y,z}; A, B, C, D** are numerical linearization parameters assessed based on the data of power sweep for specific modulation signal. The parameters do not depend on frequency nor media. VR is the maximum calibration range expressed in RMS voltage across the diode.
- ConvF and Boundary Effect Parameters**: Assessed in flat phantom using E-field (or Temperature Transfer Standard for $f \leq 800$ MHz) and inside waveguide using analytical field distributions based on power measurements for $f > 800$ MHz. The same setups are used for assessment of the parameters applied for boundary compensation (alpha, depth) of which typical uncertainty values are given. These parameters are used in DASY4 software to improve probe accuracy close to the boundary. The sensitivity in TSL corresponds to NORM_{x,y,z} * ConvF whereby the uncertainty corresponds to that given for ConvF. A frequency dependent ConvF is used in DASY version 4.4 and higher which allows extending the validity from ± 50 MHz to ± 100 MHz.
- Spherical isotropy (3D deviation from isotropy)**: in a field of low gradients realized using a flat phantom exposed by a patch antenna.
- Sensor Offset**: The sensor offset corresponds to the offset of virtual measurement center from the probe tip (on probe axis). No tolerance required.
- Connector Angle**: The angle is assessed using the information gained by determining the NORM_x (no uncertainty required).

Probe ES3DV3

SN:3332

Manufactured: January 24, 2012
Calibrated: August 14, 2017

Calibrated for DASY/EASY Systems
(Note: non-compatible with DASY2 system!)

DASY/EASY - Parameters of Probe: ES3DV3 - SN:3332

Basic Calibration Parameters

	Sensor X	Sensor Y	Sensor Z	Unc (k=2)
Norm ($\mu\text{V}/(\text{V}/\text{m})^2$) ^A	1.00	0.93	0.88	$\pm 10.1 \%$
DCP (mV) ^B	104.0	103.0	103.0	

Modulation Calibration Parameters

UID	Communication System Name		A dB	B dB $\sqrt{\mu\text{V}}$	C	D dB	VR mV	Unc ^E (k=2)
0	CW	X	0.0	0.0	1.0	0.00	192.0	$\pm 3.5 \%$
		Y	0.0	0.0	1.0		194.3	
		Z	0.0	0.0	1.0		179.9	

Note: For details on UID parameters see Appendix.

Sensor Model Parameters

	C1 fF	C2 fF	α V ⁻¹	T1 ms.V ⁻²	T2 ms.V ⁻¹	T3 ms	T4 V ⁻²	T5 V ⁻¹	T6
X	76.72	548.9	35.46	56.44	4.600	5.1	0.000	0.903	1.011
Y	44.78	323.3	35.85	29.01	2.529	5.1	0.000	0.546	1.009
Z	38.01	268.3	34.56	26.38	1.777	5.1	0.096	0.424	1.004

The reported uncertainty of measurement is stated as the standard uncertainty of measurement multiplied by the coverage factor k=2, which for a normal distribution corresponds to a coverage probability of approximately 95%.

^A The uncertainties of Norm X,Y,Z do not affect the E²-field uncertainty inside TSL (see Pages 5 and 6).

^B Numerical linearization parameter: uncertainty not required.

^E Uncertainty is determined using the max. deviation from linear response applying rectangular distribution and is expressed for the square of the field value.

DASY/EASY - Parameters of Probe: ES3DV3 - SN:3332

Calibration Parameter Determined in Head Tissue Simulating Media

f (MHz) ^C	Relative Permittivity ^F	Conductivity (S/m) ^F	ConvF X	ConvF Y	ConvF Z	Alpha ^G	Depth ^G (mm)	Unc (k=2)
750	41.9	0.89	6.81	6.81	6.81	0.72	1.31	± 12.0 %
835	41.5	0.90	6.64	6.64	6.64	0.80	1.21	± 12.0 %
1750	40.1	1.37	5.56	5.56	5.56	0.80	1.20	± 12.0 %
1900	40.0	1.40	5.33	5.33	5.33	0.76	1.26	± 12.0 %
2300	39.5	1.67	4.99	4.99	4.99	0.70	1.36	± 12.0 %
2450	39.2	1.80	4.68	4.68	4.68	0.63	1.48	± 12.0 %
2600	39.0	1.96	4.56	4.56	4.56	0.80	1.23	± 12.0 %

^C Frequency validity above 300 MHz of ± 100 MHz only applies for DASY v4.4 and higher (see Page 2), else it is restricted to ± 50 MHz. The uncertainty is the RSS of the ConvF uncertainty at calibration frequency and the uncertainty for the indicated frequency band. Frequency validity below 300 MHz is ± 10, 25, 40, 50 and 70 MHz for ConvF assessments at 30, 64, 128, 150 and 220 MHz respectively. Above 5 GHz frequency validity can be extended to ± 110 MHz.

^F At frequencies below 3 GHz, the validity of tissue parameters (ϵ and σ) can be relaxed to ± 10% if liquid compensation formula is applied to measured SAR values. At frequencies above 3 GHz, the validity of tissue parameters (ϵ and σ) is restricted to ± 5%. The uncertainty is the RSS of the ConvF uncertainty for indicated target tissue parameters.

^G Alpha/Depth are determined during calibration. SPEAG warrants that the remaining deviation due to the boundary effect after compensation is always less than ± 1% for frequencies below 3 GHz and below ± 2% for frequencies between 3-6 GHz at any distance larger than half the probe tip diameter from the boundary.

DASY/EASY - Parameters of Probe: ES3DV3 - SN:3332

Calibration Parameter Determined in Body Tissue Simulating Media

f (MHz) ^C	Relative Permittivity ^F	Conductivity (S/m) ^F	ConvF X	ConvF Y	ConvF Z	Alpha ^G	Depth ^G (mm)	Unc (k=2)
750	55.5	0.96	6.54	6.54	6.54	0.55	1.43	± 12.0 %
835	55.2	0.97	6.47	6.47	6.47	0.71	1.27	± 12.0 %
1750	53.4	1.49	5.16	5.16	5.16	0.80	1.22	± 12.0 %
1900	53.3	1.52	4.95	4.95	4.95	0.54	1.56	± 12.0 %
2300	52.9	1.81	4.74	4.74	4.74	0.80	1.30	± 12.0 %
2450	52.7	1.95	4.55	4.55	4.55	0.80	1.17	± 12.0 %
2600	52.5	2.16	4.43	4.43	4.43	0.80	1.12	± 12.0 %

^C Frequency validity above 300 MHz of ± 100 MHz only applies for DASY v4.4 and higher (see Page 2), else it is restricted to ± 50 MHz. The uncertainty is the RSS of the ConvF uncertainty at calibration frequency and the uncertainty for the indicated frequency band. Frequency validity below 300 MHz is ± 10, 25, 40, 50 and 70 MHz for ConvF assessments at 30, 64, 128, 150 and 220 MHz respectively. Above 5 GHz frequency validity can be extended to ± 110 MHz.

^F At frequencies below 3 GHz, the validity of tissue parameters (ϵ and σ) can be relaxed to ± 10% if liquid compensation formula is applied to measured SAR values. At frequencies above 3 GHz, the validity of tissue parameters (ϵ and σ) is restricted to ± 5%. The uncertainty is the RSS of the ConvF uncertainty for indicated target tissue parameters.

^G Alpha/Depth are determined during calibration. SPEAG warrants that the remaining deviation due to the boundary effect after compensation is always less than ± 1% for frequencies below 3 GHz and below ± 2% for frequencies between 3-6 GHz at any distance larger than half the probe tip diameter from the boundary.

Frequency Response of E-Field

(TEM-Cell:ifi110 EXX, Waveguide: R22)

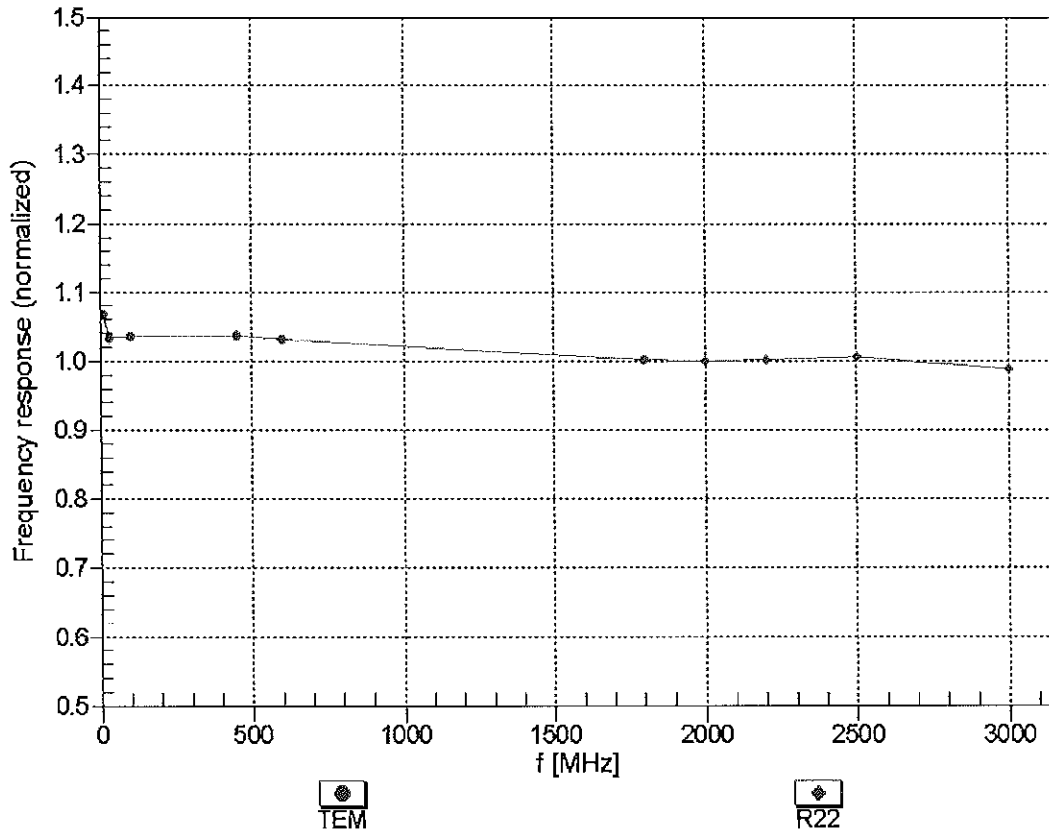

Uncertainty of Frequency Response of E-field: $\pm 6.3\%$ (k=2)

Receiving Pattern (ϕ), $\vartheta = 0^\circ$

f=600 MHz,TEM

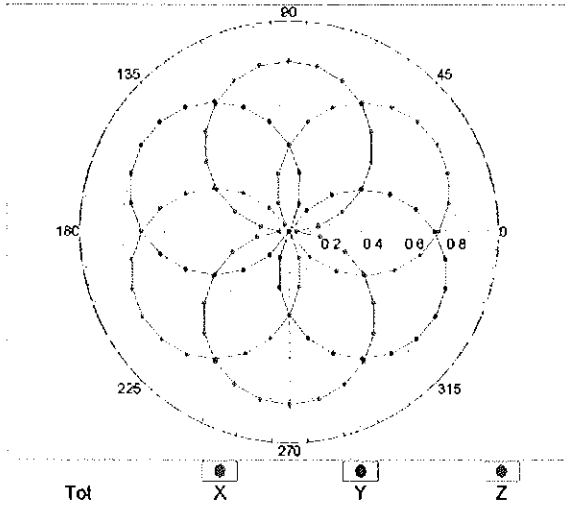

f=1800 MHz,R22

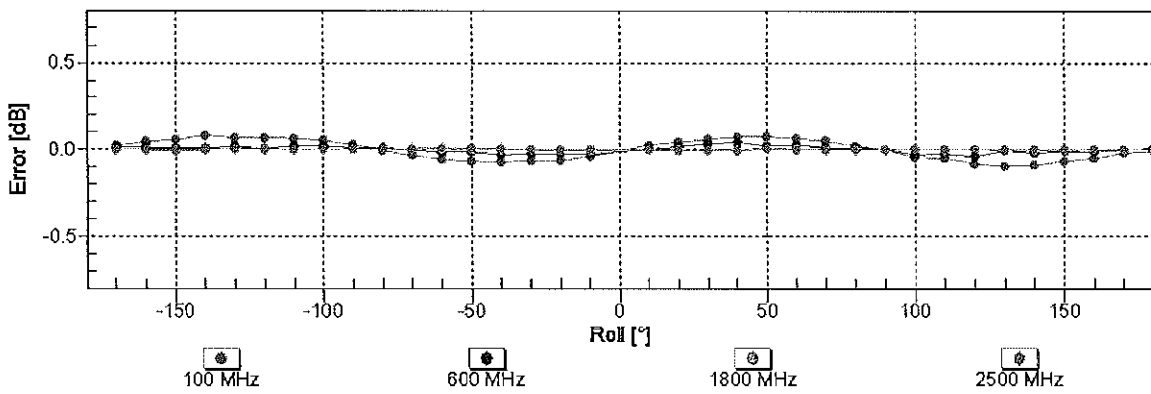
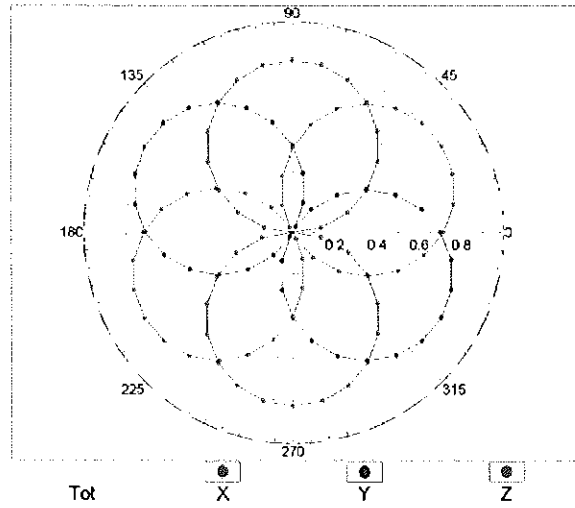

Uncertainty of Axial Isotropy Assessment: $\pm 0.5\%$ (k=2)

Dynamic Range f(SAR_{head}) (TEM cell , f_{eval}= 1900 MHz)

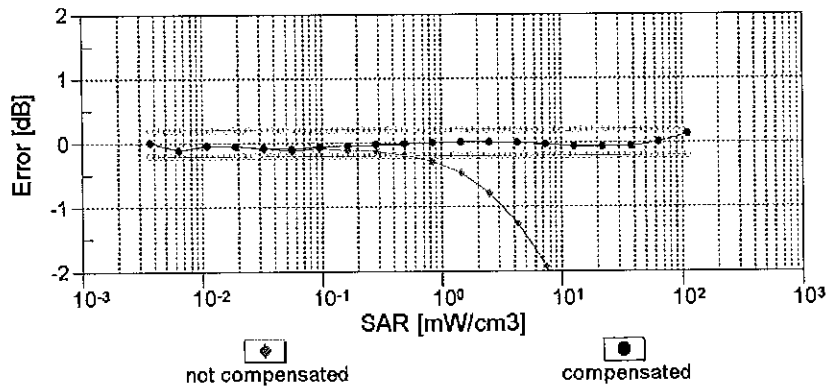
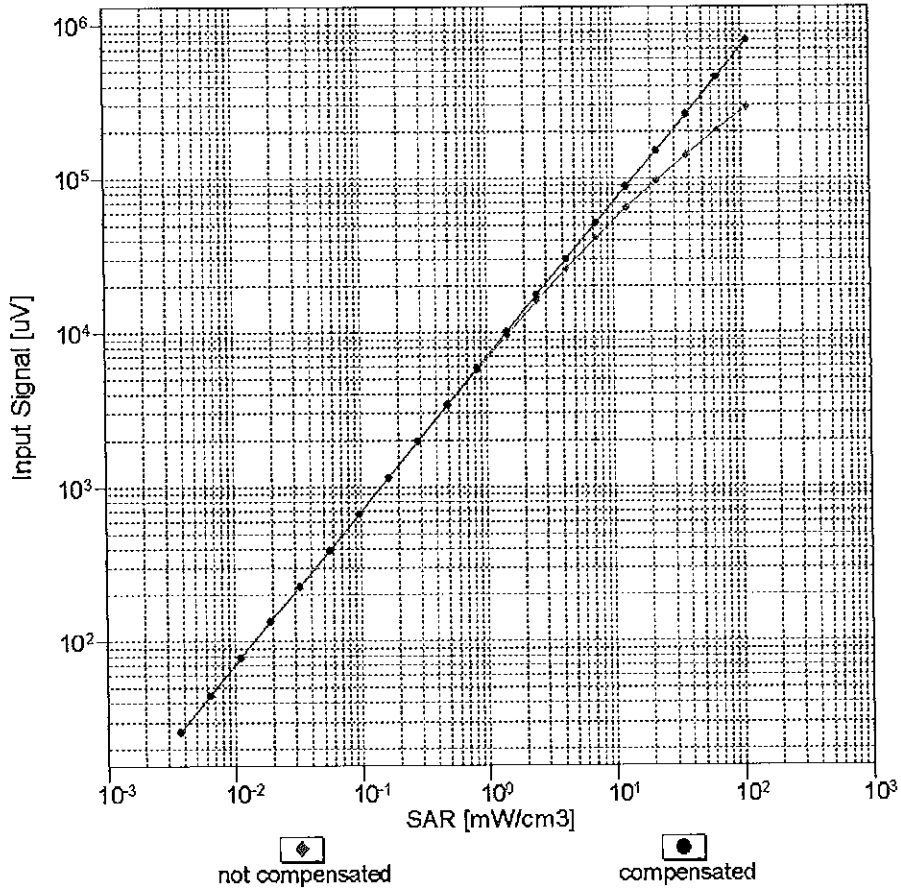

Uncertainty of Linearity Assessment: ± 0.6% (k=2)

Conversion Factor Assessment

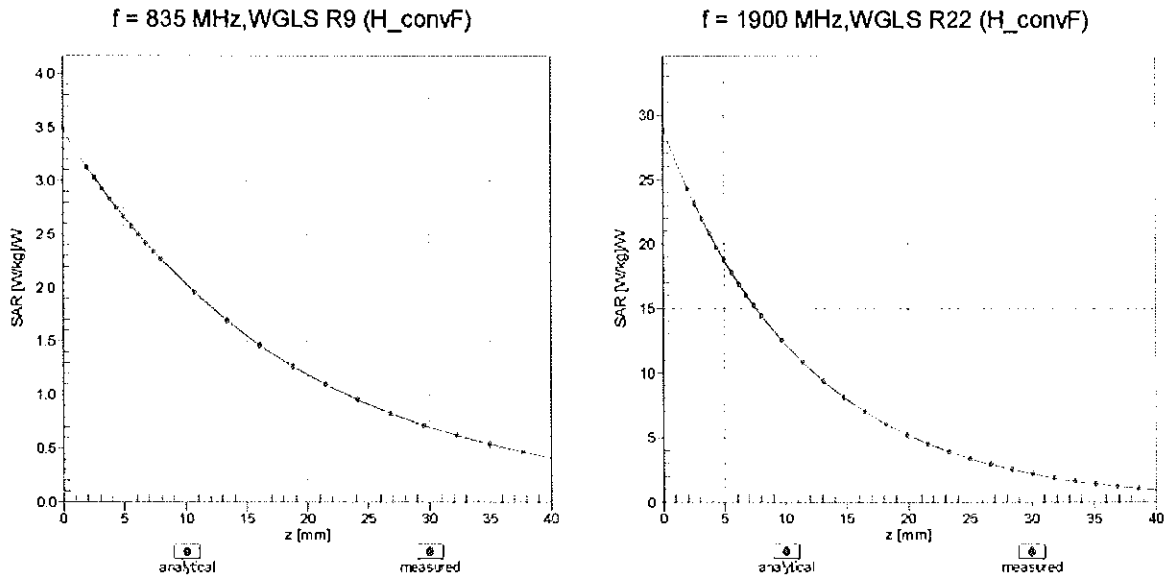

Deviation from Isotropy in Liquid Error (ϕ, ϑ), f = 900 MHz

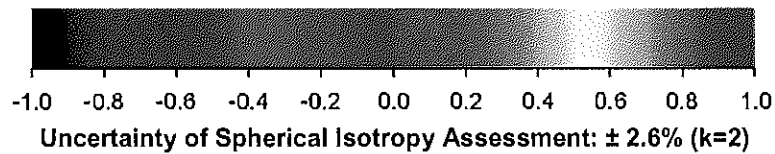
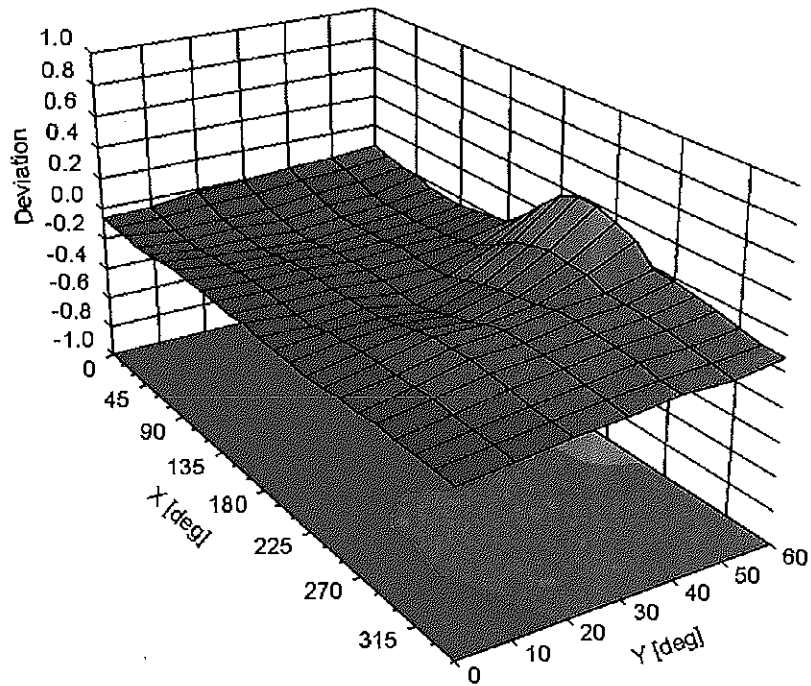

DASY/EASY - Parameters of Probe: ES3DV3 - SN:3332**Other Probe Parameters**

Sensor Arrangement	Triangular
Connector Angle (°)	50
Mechanical Surface Detection Mode	enabled
Optical Surface Detection Mode	disabled
Probe Overall Length	337 mm
Probe Body Diameter	10 mm
Tip Length	10 mm
Tip Diameter	4 mm
Probe Tip to Sensor X Calibration Point	2 mm
Probe Tip to Sensor Y Calibration Point	2 mm
Probe Tip to Sensor Z Calibration Point	2 mm
Recommended Measurement Distance from Surface	3 mm

Appendix: Modulation Calibration Parameters

UID	Communication System Name		A dB	B dB/μV	C	D dB	VR mV	Max Unc ^E (k=2)
0	CW	X	0.00	0.00	1.00	0.00	192.0	± 3.5 %
		Y	0.00	0.00	1.00		194.3	
		Z	0.00	0.00	1.00		179.9	
10010- CAA	SAR Validation (Square, 100ms, 10ms)	X	9.02	77.08	18.94	10.00	25.0	± 9.6 %
		Y	12.19	85.73	21.41		25.0	
		Z	23.02	95.31	23.86		25.0	
10011- CAB	UMTS-FDD (WCDMA)	X	1.60	76.05	19.77	0.00	150.0	± 9.6 %
		Y	1.08	68.15	15.73		150.0	
		Z	1.25	71.36	17.60		150.0	
10012- CAB	IEEE 802.11b WiFi 2.4 GHz (DSSS, 1 Mbps)	X	1.52	68.53	17.98	0.41	150.0	± 9.6 %
		Y	1.33	65.39	16.06		150.0	
		Z	1.37	66.35	16.79		150.0	
10013- CAB	IEEE 802.11g WiFi 2.4 GHz (DSSS-OFDM, 6 Mbps)	X	5.37	67.71	17.82	1.46	150.0	± 9.6 %
		Y	5.07	67.50	17.57		150.0	
		Z	4.99	67.81	17.71		150.0	
10021- DAC	GSM-FDD (TDMA, GMSK)	X	11.16	81.48	22.11	9.39	50.0	± 9.6 %
		Y	61.59	115.23	32.13		50.0	
		Z	100.00	122.78	33.35		50.0	
10023- DAC	GPRS-FDD (TDMA, GMSK, TN 0)	X	11.07	81.20	22.06	9.57	50.0	± 9.6 %
		Y	43.11	109.07	30.52		50.0	
		Z	100.00	122.63	33.33		50.0	
10024- DAC	GPRS-FDD (TDMA, GMSK, TN 0-1)	X	12.88	85.34	22.06	6.56	60.0	± 9.6 %
		Y	100.00	120.15	31.36		60.0	
		Z	100.00	120.25	30.99		60.0	
10025- DAC	EDGE-FDD (TDMA, 8PSK, TN 0)	X	19.49	99.22	36.41	12.57	50.0	± 9.6 %
		Y	15.67	100.74	38.44		50.0	
		Z	29.43	124.69	47.97		50.0	
10026- DAC	EDGE-FDD (TDMA, 8PSK, TN 0-1)	X	18.92	96.32	32.19	9.56	60.0	± 9.6 %
		Y	17.33	101.02	35.08		60.0	
		Z	24.89	113.23	39.81		60.0	
10027- DAC	GPRS-FDD (TDMA, GMSK, TN 0-1-2)	X	24.19	95.70	24.33	4.80	80.0	± 9.6 %
		Y	100.00	119.30	30.03		80.0	
		Z	100.00	120.36	30.17		80.0	
10028- DAC	GPRS-FDD (TDMA, GMSK, TN 0-1-2-3)	X	100.00	115.36	28.49	3.55	100.0	± 9.6 %
		Y	100.00	119.83	29.45		100.0	
		Z	100.00	122.10	30.18		100.0	
10029- DAC	EDGE-FDD (TDMA, 8PSK, TN 0-1-2)	X	16.27	93.78	30.32	7.80	80.0	± 9.6 %
		Y	11.67	92.24	30.90		80.0	
		Z	13.37	97.80	33.46		80.0	
10030- CAA	IEEE 802.15.1 Bluetooth (GFSK, DH1)	X	15.68	88.86	22.54	5.30	70.0	± 9.6 %
		Y	100.00	118.49	29.99		70.0	
		Z	100.00	118.88	29.80		70.0	
10031- CAA	IEEE 802.15.1 Bluetooth (GFSK, DH3)	X	100.00	116.01	27.12	1.88	100.0	± 9.6 %
		Y	100.00	121.13	28.42		100.0	
		Z	100.00	126.03	30.32		100.0	

10032-CAA	IEEE 802.15.1 Bluetooth (GFSK, DH5)	X	100.00	119.38	27.36	1.17	100.0	± 9.6 %
		Y	100.00	126.54	29.58		100.0	
		Z	100.00	136.16	33.43		100.0	
10033-CAA	IEEE 802.15.1 Bluetooth (PI/4-DQPSK, DH1)	X	13.27	88.21	24.10	5.30	70.0	± 9.6 %
		Y	20.91	99.02	27.13		70.0	
		Z	58.05	115.59	31.27		70.0	
10034-CAA	IEEE 802.15.1 Bluetooth (PI/4-DQPSK, DH3)	X	16.18	96.67	25.44	1.88	100.0	± 9.6 %
		Y	10.83	91.57	22.94		100.0	
		Z	52.78	113.06	28.24		100.0	
10035-CAA	IEEE 802.15.1 Bluetooth (PI/4-DQPSK, DH5)	X	12.45	95.04	24.79	1.17	100.0	± 9.6 %
		Y	5.49	83.70	20.10		100.0	
		Z	18.62	100.06	24.56		100.0	
10036-CAA	IEEE 802.15.1 Bluetooth (8-DPSK, DH1)	X	14.34	89.63	24.62	5.30	70.0	± 9.6 %
		Y	26.79	103.24	28.41		70.0	
		Z	95.10	123.67	33.30		70.0	
10037-CAA	IEEE 802.15.1 Bluetooth (8-DPSK, DH3)	X	15.98	96.45	25.32	1.88	100.0	± 9.6 %
		Y	9.62	89.98	22.43		100.0	
		Z	37.04	108.35	27.08		100.0	
10038-CAA	IEEE 802.15.1 Bluetooth (8-DPSK, DH5)	X	13.91	96.94	25.41	1.17	100.0	± 9.6 %
		Y	5.69	84.50	20.47		100.0	
		Z	19.52	101.18	25.01		100.0	
10039-CAB	CDMA2000 (1xRTT, RC1)	X	3.28	80.46	20.53	0.00	150.0	± 9.6 %
		Y	1.92	73.09	15.89		150.0	
		Z	3.08	80.13	18.22		150.0	
10042-CAB	IS-54 / IS-136 FDD (TDMA/FDM, PI/4-DQPSK, Halfrate)	X	11.60	82.51	21.10	7.78	50.0	± 9.6 %
		Y	100.00	118.83	31.00		50.0	
		Z	100.00	118.47	30.39		50.0	
10044-CAA	IS-91/EIA/TIA-553 FDD (FDMA, FM)	X	0.02	128.88	9.05	0.00	150.0	± 9.6 %
		Y	0.00	96.92	0.26		150.0	
		Z	0.02	60.00	140.78		150.0	
10048-CAA	DECT (TDD, TDMA/FDM, GFSK, Full Slot, 24)	X	10.75	78.30	22.86	13.80	25.0	± 9.6 %
		Y	15.61	90.30	26.65		25.0	
		Z	32.75	104.57	30.45		25.0	
10049-CAA	DECT (TDD, TDMA/FDM, GFSK, Double Slot, 12)	X	10.92	80.23	22.15	10.79	40.0	± 9.6 %
		Y	20.87	96.36	27.22		40.0	
		Z	64.62	115.72	32.06		40.0	
10056-CAA	UMTS-TDD (TD-SCDMA, 1.28 Mcps)	X	11.51	81.76	22.84	9.03	50.0	± 9.6 %
		Y	15.28	90.93	25.77		50.0	
		Z	25.94	101.11	28.65		50.0	
10058-DAC	EDGE-FDD (TDMA, 8PSK, TN 0-1-2-3)	X	14.19	91.88	29.00	6.55	100.0	± 9.6 %
		Y	8.68	86.53	28.09		100.0	
		Z	9.12	89.51	29.70		100.0	
10059-CAB	IEEE 802.11b WiFi 2.4 GHz (DSSS, 2 Mbps)	X	2.01	72.72	19.70	0.61	110.0	± 9.6 %
		Y	1.51	67.62	17.16		110.0	
		Z	1.56	68.78	17.99		110.0	
10060-CAB	IEEE 802.11b WiFi 2.4 GHz (DSSS, 5.5 Mbps)	X	100.00	126.29	32.07	1.30	110.0	± 9.6 %
		Y	100.00	132.71	34.39		110.0	
		Z	100.00	137.07	36.21		110.0	

10061-CAB	IEEE 802.11b WiFi 2.4 GHz (DSSS, 11 Mbps)	X	36.66	112.50	30.92	2.04	110.0	± 9.6 %
		Y	11.07	98.15	27.76		110.0	
		Z	22.12	112.16	32.18		110.0	
10062-CAB	IEEE 802.11a/h WiFi 5 GHz (OFDM, 6 Mbps)	X	5.03	67.33	17.05	0.49	100.0	± 9.6 %
		Y	4.77	67.19	16.82		100.0	
		Z	4.70	67.51	16.97		100.0	
10063-CAB	IEEE 802.11a/h WiFi 5 GHz (OFDM, 9 Mbps)	X	5.09	67.56	17.23	0.72	100.0	± 9.6 %
		Y	4.81	67.36	16.96		100.0	
		Z	4.74	67.68	17.11		100.0	
10064-CAB	IEEE 802.11a/h WiFi 5 GHz (OFDM, 12 Mbps)	X	5.47	67.93	17.49	0.86	100.0	± 9.6 %
		Y	5.10	67.63	17.20		100.0	
		Z	5.00	67.90	17.32		100.0	
10065-CAB	IEEE 802.11a/h WiFi 5 GHz (OFDM, 18 Mbps)	X	5.40	68.08	17.70	1.21	100.0	± 9.6 %
		Y	5.02	67.68	17.39		100.0	
		Z	4.92	67.92	17.50		100.0	
10066-CAB	IEEE 802.11a/h WiFi 5 GHz (OFDM, 24 Mbps)	X	5.49	68.31	17.98	1.46	100.0	± 9.6 %
		Y	5.08	67.82	17.62		100.0	
		Z	4.97	68.04	17.73		100.0	
10067-CAB	IEEE 802.11a/h WiFi 5 GHz (OFDM, 36 Mbps)	X	5.84	68.47	18.45	2.04	100.0	± 9.6 %
		Y	5.42	68.13	18.14		100.0	
		Z	5.31	68.42	18.28		100.0	
10068-CAB	IEEE 802.11a/h WiFi 5 GHz (OFDM, 48 Mbps)	X	6.07	69.08	18.91	2.55	100.0	± 9.6 %
		Y	5.53	68.32	18.44		100.0	
		Z	5.39	68.51	18.54		100.0	
10069-CAB	IEEE 802.11a/h WiFi 5 GHz (OFDM, 54 Mbps)	X	6.13	68.90	19.06	2.67	100.0	± 9.6 %
		Y	5.61	68.37	18.66		100.0	
		Z	5.48	68.58	18.76		100.0	
10071-CAB	IEEE 802.11g WiFi 2.4 GHz (DSSS/OFDM, 9 Mbps)	X	5.56	68.08	18.26	1.99	100.0	± 9.6 %
		Y	5.22	67.75	17.96		100.0	
		Z	5.14	68.03	18.10		100.0	
10072-CAB	IEEE 802.11g WiFi 2.4 GHz (DSSS/OFDM, 12 Mbps)	X	5.71	68.87	18.66	2.30	100.0	± 9.6 %
		Y	5.28	68.28	18.29		100.0	
		Z	5.18	68.53	18.42		100.0	
10073-CAB	IEEE 802.11g WiFi 2.4 GHz (DSSS/OFDM, 18 Mbps)	X	5.93	69.43	19.17	2.83	100.0	± 9.6 %
		Y	5.43	68.68	18.74		100.0	
		Z	5.32	68.95	18.89		100.0	
10074-CAB	IEEE 802.11g WiFi 2.4 GHz (DSSS/OFDM, 24 Mbps)	X	6.04	69.75	19.56	3.30	100.0	± 9.6 %
		Y	5.49	68.80	18.99		100.0	
		Z	5.38	69.07	19.15		100.0	
10075-CAB	IEEE 802.11g WiFi 2.4 GHz (DSSS/OFDM, 36 Mbps)	X	6.35	70.65	20.23	3.82	90.0	± 9.6 %
		Y	5.63	69.18	19.44		90.0	
		Z	5.49	69.37	19.56		90.0	
10076-CAB	IEEE 802.11g WiFi 2.4 GHz (DSSS/OFDM, 48 Mbps)	X	6.37	70.50	20.38	4.15	90.0	± 9.6 %
		Y	5.68	69.10	19.63		90.0	
		Z	5.56	69.34	19.78		90.0	
10077-CAB	IEEE 802.11g WiFi 2.4 GHz (DSSS/OFDM, 54 Mbps)	X	6.43	70.65	20.50	4.30	90.0	± 9.6 %
		Y	5.73	69.22	19.75		90.0	
		Z	5.61	69.48	19.91		90.0	

10081-CAB	CDMA2000 (1xRTT, RC3)	X	1.62	75.66	18.40	0.00	150.0	± 9.6 %
		Y	0.87	66.71	12.69		150.0	
		Z	1.13	71.02	14.45		150.0	
10082-CAB	IS-54 / IS-136 FDD (TDMA/FDM, PI/4-DQPSK, Fullrate)	X	3.53	66.20	10.93	4.77	80.0	± 9.6 %
		Y	2.19	64.40	9.18		80.0	
		Z	1.96	64.15	8.74		80.0	
10090-DAC	GPRS-FDD (TDMA, GMSK, TN 0-4)	X	12.79	85.25	22.06	6.56	60.0	± 9.6 %
		Y	100.00	120.23	31.42		60.0	
		Z	100.00	120.31	31.04		60.0	
10097-CAB	UMTS-FDD (HSDPA)	X	2.06	70.06	17.46	0.00	150.0	± 9.6 %
		Y	1.88	68.31	15.96		150.0	
		Z	2.04	70.38	16.98		150.0	
10098-CAB	UMTS-FDD (HSUPA, Subtest 2)	X	2.02	70.12	17.47	0.00	150.0	± 9.6 %
		Y	1.84	68.27	15.94		150.0	
		Z	2.00	70.37	16.98		150.0	
10099-DAC	EDGE-FDD (TDMA, 8PSK, TN 0-4)	X	18.80	96.14	32.13	9.56	60.0	± 9.6 %
		Y	17.28	100.91	35.04		60.0	
		Z	24.81	113.10	39.77		60.0	
10100-CAD	LTE-FDD (SC-FDMA, 100% RB, 20 MHz, QPSK)	X	3.84	73.61	18.19	0.00	150.0	± 9.6 %
		Y	3.15	70.58	16.91		150.0	
		Z	3.25	71.69	17.61		150.0	
10101-CAD	LTE-FDD (SC-FDMA, 100% RB, 20 MHz, 16-QAM)	X	3.58	69.11	16.83	0.00	150.0	± 9.6 %
		Y	3.26	67.74	16.10		150.0	
		Z	3.26	68.29	16.47		150.0	
10102-CAD	LTE-FDD (SC-FDMA, 100% RB, 20 MHz, 64-QAM)	X	3.66	68.88	16.84	0.00	150.0	± 9.6 %
		Y	3.36	67.71	16.19		150.0	
		Z	3.36	68.23	16.52		150.0	
10103-CAD	LTE-TDD (SC-FDMA, 100% RB, 20 MHz, QPSK)	X	9.75	77.78	20.81	3.98	65.0	± 9.6 %
		Y	8.78	79.16	21.83		65.0	
		Z	9.34	81.38	22.82		65.0	
10104-CAD	LTE-TDD (SC-FDMA, 100% RB, 20 MHz, 16-QAM)	X	9.87	77.22	21.49	3.98	65.0	± 9.6 %
		Y	8.42	77.09	21.77		65.0	
		Z	8.44	78.16	22.31		65.0	
10105-CAD	LTE-TDD (SC-FDMA, 100% RB, 20 MHz, 64-QAM)	X	9.19	75.82	21.15	3.98	65.0	± 9.6 %
		Y	8.07	76.20	21.66		65.0	
		Z	8.27	77.70	22.41		65.0	
10108-CAE	LTE-FDD (SC-FDMA, 100% RB, 10 MHz, QPSK)	X	3.37	72.69	18.02	0.00	150.0	± 9.6 %
		Y	2.75	69.90	16.77		150.0	
		Z	2.82	71.09	17.51		150.0	
10109-CAE	LTE-FDD (SC-FDMA, 100% RB, 10 MHz, 16-QAM)	X	3.26	68.97	16.85	0.00	150.0	± 9.6 %
		Y	2.91	67.66	16.01		150.0	
		Z	2.92	68.36	16.42		150.0	
10110-CAE	LTE-FDD (SC-FDMA, 100% RB, 5 MHz, QPSK)	X	2.79	71.81	17.85	0.00	150.0	± 9.6 %
		Y	2.23	69.12	16.39		150.0	
		Z	2.31	70.62	17.23		150.0	
10111-CAE	LTE-FDD (SC-FDMA, 100% RB, 5 MHz, 16-QAM)	X	2.96	69.58	17.27	0.00	150.0	± 9.6 %
		Y	2.63	68.64	16.31		150.0	
		Z	2.69	69.84	16.85		150.0	

10112-CAE	LTE-FDD (SC-FDMA, 100% RB, 10 MHz, 64-QAM)	X	3.36	68.71	16.80	0.00	150.0	± 9.6 %
		Y	3.03	67.66	16.06		150.0	
		Z	3.04	68.35	16.45		150.0	
10113-CAE	LTE-FDD (SC-FDMA, 100% RB, 5 MHz, 64-QAM)	X	3.10	69.46	17.27	0.00	150.0	± 9.6 %
		Y	2.78	68.78	16.44		150.0	
		Z	2.83	69.92	16.93		150.0	
10114-CAB	IEEE 802.11n (HT Greenfield, 13.5 Mbps, BPSK)	X	5.34	67.65	16.76	0.00	150.0	± 9.6 %
		Y	5.17	67.50	16.64		150.0	
		Z	5.08	67.64	16.74		150.0	
10115-CAB	IEEE 802.11n (HT Greenfield, 81 Mbps, 16-QAM)	X	5.80	68.17	17.01	0.00	150.0	± 9.6 %
		Y	5.44	67.60	16.69		150.0	
		Z	5.33	67.71	16.77		150.0	
10116-CAB	IEEE 802.11n (HT Greenfield, 135 Mbps, 64-QAM)	X	5.47	67.90	16.79	0.00	150.0	± 9.6 %
		Y	5.25	67.68	16.65		150.0	
		Z	5.17	67.85	16.77		150.0	
10117-CAB	IEEE 802.11n (HT Mixed, 13.5 Mbps, BPSK)	X	5.34	67.65	16.78	0.00	150.0	± 9.6 %
		Y	5.12	67.32	16.56		150.0	
		Z	5.07	67.59	16.73		150.0	
10118-CAB	IEEE 802.11n (HT Mixed, 81 Mbps, 16-QAM)	X	5.79	68.04	16.95	0.00	150.0	± 9.6 %
		Y	5.52	67.82	16.81		150.0	
		Z	5.42	67.93	16.89		150.0	
10119-CAB	IEEE 802.11n (HT Mixed, 135 Mbps, 64-QAM)	X	5.44	67.84	16.78	0.00	150.0	± 9.6 %
		Y	5.24	67.66	16.65		150.0	
		Z	5.17	67.84	16.77		150.0	
10140-CAD	LTE-FDD (SC-FDMA, 100% RB, 15 MHz, 16-QAM)	X	3.72	68.86	16.76	0.00	150.0	± 9.6 %
		Y	3.39	67.72	16.10		150.0	
		Z	3.39	68.26	16.45		150.0	
10141-CAD	LTE-FDD (SC-FDMA, 100% RB, 15 MHz, 64-QAM)	X	3.82	68.79	16.84	0.00	150.0	± 9.6 %
		Y	3.51	67.83	16.27		150.0	
		Z	3.51	68.36	16.60		150.0	
10142-CAD	LTE-FDD (SC-FDMA, 100% RB, 3 MHz, QPSK)	X	2.57	71.96	17.88	0.00	150.0	± 9.6 %
		Y	2.01	69.21	16.02		150.0	
		Z	2.13	71.18	16.95		150.0	
10143-CAD	LTE-FDD (SC-FDMA, 100% RB, 3 MHz, 16-QAM)	X	2.89	70.53	17.42	0.00	150.0	± 9.6 %
		Y	2.49	69.45	15.95		150.0	
		Z	2.62	71.11	16.52		150.0	
10144-CAD	LTE-FDD (SC-FDMA, 100% RB, 3 MHz, 64-QAM)	X	2.69	68.52	16.05	0.00	150.0	± 9.6 %
		Y	2.23	66.92	14.20		150.0	
		Z	2.23	67.85	14.42		150.0	
10145-CAE	LTE-FDD (SC-FDMA, 100% RB, 1.4 MHz, QPSK)	X	2.07	72.06	16.97	0.00	150.0	± 9.6 %
		Y	1.17	64.90	11.31		150.0	
		Z	1.08	64.84	10.72		150.0	
10146-CAE	LTE-FDD (SC-FDMA, 100% RB, 1.4 MHz, 16-QAM)	X	4.64	77.66	18.95	0.00	150.0	± 9.6 %
		Y	1.89	66.33	11.57		150.0	
		Z	1.28	62.78	8.70		150.0	
10147-CAE	LTE-FDD (SC-FDMA, 100% RB, 1.4 MHz, 64-QAM)	X	5.86	81.36	20.54	0.00	150.0	± 9.6 %
		Y	2.26	68.50	12.73		150.0	
		Z	1.39	63.59	9.24		150.0	

10149-CAD	LTE-FDD (SC-FDMA, 50% RB, 20 MHz, 16-QAM)	X	3.27	69.03	16.89	0.00	150.0	± 9.6 %
		Y	2.92	67.72	16.06		150.0	
		Z	2.93	68.43	16.47		150.0	
10150-CAD	LTE-FDD (SC-FDMA, 50% RB, 20 MHz, 64-QAM)	X	3.37	68.76	16.84	0.00	150.0	± 9.6 %
		Y	3.04	67.71	16.11		150.0	
		Z	3.05	68.41	16.50		150.0	
10151-CAD	LTE-TDD (SC-FDMA, 50% RB, 20 MHz, QPSK)	X	9.88	78.98	21.39	3.98	65.0	± 9.6 %
		Y	9.54	82.00	22.98		65.0	
		Z	10.52	85.01	24.21		65.0	
10152-CAD	LTE-TDD (SC-FDMA, 50% RB, 20 MHz, 16-QAM)	X	9.59	77.49	21.44	3.98	65.0	± 9.6 %
		Y	8.05	77.33	21.53		65.0	
		Z	8.15	78.63	22.11		65.0	
10153-CAD	LTE-TDD (SC-FDMA, 50% RB, 20 MHz, 64-QAM)	X	9.88	78.01	21.96	3.98	65.0	± 9.6 %
		Y	8.51	78.32	22.28		65.0	
		Z	8.64	79.68	22.87		65.0	
10154-CAE	LTE-FDD (SC-FDMA, 50% RB, 10 MHz, QPSK)	X	2.88	72.43	18.21	0.00	150.0	± 9.6 %
		Y	2.28	69.53	16.65		150.0	
		Z	2.36	71.01	17.47		150.0	
10155-CAE	LTE-FDD (SC-FDMA, 50% RB, 10 MHz, 16-QAM)	X	2.96	69.57	17.27	0.00	150.0	± 9.6 %
		Y	2.63	68.66	16.33		150.0	
		Z	2.70	69.87	16.88		150.0	
10156-CAE	LTE-FDD (SC-FDMA, 50% RB, 5 MHz, QPSK)	X	2.50	72.75	18.17	0.00	150.0	± 9.6 %
		Y	1.86	69.32	15.77		150.0	
		Z	2.00	71.53	16.72		150.0	
10157-CAE	LTE-FDD (SC-FDMA, 50% RB, 5 MHz, 16-QAM)	X	2.58	69.56	16.46	0.00	150.0	± 9.6 %
		Y	2.07	67.52	14.21		150.0	
		Z	2.11	68.66	14.46		150.0	
10158-CAE	LTE-FDD (SC-FDMA, 50% RB, 10 MHz, 64-QAM)	X	3.11	69.51	17.31	0.00	150.0	± 9.6 %
		Y	2.79	68.85	16.49		150.0	
		Z	2.84	70.00	16.99		150.0	
10159-CAE	LTE-FDD (SC-FDMA, 50% RB, 5 MHz, 64-QAM)	X	2.70	69.94	16.71	0.00	150.0	± 9.6 %
		Y	2.17	67.94	14.47		150.0	
		Z	2.21	69.05	14.68		150.0	
10160-CAD	LTE-FDD (SC-FDMA, 50% RB, 15 MHz, QPSK)	X	3.17	70.70	17.47	0.00	150.0	± 9.6 %
		Y	2.80	69.22	16.63		150.0	
		Z	2.84	70.27	17.24		150.0	
10161-CAD	LTE-FDD (SC-FDMA, 50% RB, 15 MHz, 16-QAM)	X	3.25	68.62	16.80	0.00	150.0	± 9.6 %
		Y	2.93	67.68	16.03		150.0	
		Z	2.94	68.43	16.42		150.0	
10162-CAD	LTE-FDD (SC-FDMA, 50% RB, 15 MHz, 64-QAM)	X	3.34	68.54	16.80	0.00	150.0	± 9.6 %
		Y	3.04	67.85	16.15		150.0	
		Z	3.05	68.62	16.54		150.0	
10166-CAE	LTE-FDD (SC-FDMA, 50% RB, 1.4 MHz, QPSK)	X	4.29	71.19	20.11	3.01	150.0	± 9.6 %
		Y	3.58	69.86	19.45		150.0	
		Z	3.34	69.55	19.26		150.0	
10167-CAE	LTE-FDD (SC-FDMA, 50% RB, 1.4 MHz, 16-QAM)	X	5.65	74.34	20.64	3.01	150.0	± 9.6 %
		Y	4.34	72.64	19.86		150.0	
		Z	3.97	72.28	19.65		150.0	

10168-CAE	LTE-FDD (SC-FDMA, 50% RB, 1.4 MHz, 64-QAM)	X	6.08	75.90	21.58	3.01	150.0	± 9.6 %
		Y	4.83	75.01	21.26		150.0	
		Z	4.38	74.50	20.98		150.0	
10169-CAD	LTE-FDD (SC-FDMA, 1 RB, 20 MHz, QPSK)	X	4.41	74.54	21.42	3.01	150.0	± 9.6 %
		Y	2.96	68.83	19.02		150.0	
		Z	2.72	67.99	18.57		150.0	
10170-CAD	LTE-FDD (SC-FDMA, 1 RB, 20 MHz, 16-QAM)	X	6.70	80.82	23.44	3.01	150.0	± 9.6 %
		Y	3.91	74.17	21.18		150.0	
		Z	3.42	72.70	20.49		150.0	
10171-AAD	LTE-FDD (SC-FDMA, 1 RB, 20 MHz, 64-QAM)	X	5.50	76.54	20.93	3.01	150.0	± 9.6 %
		Y	3.29	70.45	18.57		150.0	
		Z	2.94	69.58	18.14		150.0	
10172-CAD	LTE-TDD (SC-FDMA, 1 RB, 20 MHz, QPSK)	X	25.76	101.07	30.32	6.02	65.0	± 9.6 %
		Y	18.45	102.75	32.10		65.0	
		Z	20.86	107.70	33.85		65.0	
10173-CAD	LTE-TDD (SC-FDMA, 1 RB, 20 MHz, 16-QAM)	X	19.21	92.24	26.33	6.02	65.0	± 9.6 %
		Y	26.29	105.14	31.12		65.0	
		Z	28.49	108.55	32.12		65.0	
10174-CAD	LTE-TDD (SC-FDMA, 1 RB, 20 MHz, 64-QAM)	X	17.46	89.68	25.13	6.02	65.0	± 9.6 %
		Y	21.35	100.13	29.12		65.0	
		Z	22.92	103.28	30.05		65.0	
10175-CAE	LTE-FDD (SC-FDMA, 1 RB, 10 MHz, QPSK)	X	4.34	74.12	21.15	3.01	150.0	± 9.6 %
		Y	2.93	68.55	18.79		150.0	
		Z	2.70	67.77	18.36		150.0	
10176-CAE	LTE-FDD (SC-FDMA, 1 RB, 10 MHz, 16-QAM)	X	6.71	80.84	23.45	3.01	150.0	± 9.6 %
		Y	3.92	74.20	21.19		150.0	
		Z	3.42	72.72	20.50		150.0	
10177-CAG	LTE-FDD (SC-FDMA, 1 RB, 5 MHz, QPSK)	X	4.38	74.32	21.26	3.01	150.0	± 9.6 %
		Y	2.95	68.69	18.87		150.0	
		Z	2.71	67.87	18.43		150.0	
10178-CAE	LTE-FDD (SC-FDMA, 1 RB, 5 MHz, 16-QAM)	X	6.59	80.50	23.29	3.01	150.0	± 9.6 %
		Y	3.89	74.02	21.09		150.0	
		Z	3.41	72.61	20.43		150.0	
10179-CAE	LTE-FDD (SC-FDMA, 1 RB, 10 MHz, 64-QAM)	X	6.03	78.45	22.01	3.01	150.0	± 9.6 %
		Y	3.58	72.24	19.76		150.0	
		Z	3.16	71.11	19.23		150.0	
10180-CAE	LTE-FDD (SC-FDMA, 1 RB, 5 MHz, 64-QAM)	X	5.47	76.42	20.86	3.01	150.0	± 9.6 %
		Y	3.28	70.40	18.53		150.0	
		Z	2.94	69.55	18.12		150.0	
10181-CAD	LTE-FDD (SC-FDMA, 1 RB, 15 MHz, QPSK)	X	4.38	74.30	21.25	3.01	150.0	± 9.6 %
		Y	2.95	68.67	18.87		150.0	
		Z	2.71	67.86	18.43		150.0	
10182-CAD	LTE-FDD (SC-FDMA, 1 RB, 15 MHz, 16-QAM)	X	6.58	80.48	23.29	3.01	150.0	± 9.6 %
		Y	3.88	74.00	21.08		150.0	
		Z	3.40	72.59	20.42		150.0	
10183-AAC	LTE-FDD (SC-FDMA, 1 RB, 15 MHz, 64-QAM)	X	5.46	76.40	20.85	3.01	150.0	± 9.6 %
		Y	3.28	70.38	18.52		150.0	
		Z	2.93	69.53	18.11		150.0	

10184-CAD	LTE-FDD (SC-FDMA, 1 RB, 3 MHz, QPSK)	X	4.39	74.34	21.27	3.01	150.0	± 9.6 %
		Y	2.96	68.71	18.89		150.0	
		Z	2.72	67.89	18.44		150.0	
10185-CAD	LTE-FDD (SC-FDMA, 1 RB, 3 MHz, 16-QAM)	X	6.61	80.55	23.32	3.01	150.0	± 9.6 %
		Y	3.90	74.06	21.11		150.0	
		Z	3.42	72.64	20.45		150.0	
10186-AAD	LTE-FDD (SC-FDMA, 1 RB, 3 MHz, 64-QAM)	X	5.49	76.46	20.88	3.01	150.0	± 9.6 %
		Y	3.29	70.44	18.55		150.0	
		Z	2.95	69.59	18.14		150.0	
10187-CAE	LTE-FDD (SC-FDMA, 1 RB, 1.4 MHz, QPSK)	X	4.40	74.38	21.31	3.01	150.0	± 9.6 %
		Y	2.97	68.77	18.95		150.0	
		Z	2.73	67.95	18.51		150.0	
10188-CAE	LTE-FDD (SC-FDMA, 1 RB, 1.4 MHz, 16-QAM)	X	6.86	81.30	23.70	3.01	150.0	± 9.6 %
		Y	4.01	74.64	21.46		150.0	
		Z	3.49	73.09	20.74		150.0	
10189-AAE	LTE-FDD (SC-FDMA, 1 RB, 1.4 MHz, 64-QAM)	X	5.63	76.95	21.16	3.01	150.0	± 9.6 %
		Y	3.36	70.82	18.81		150.0	
		Z	3.00	69.90	18.37		150.0	
10193-CAB	IEEE 802.11n (HT Greenfield, 6.5 Mbps, BPSK)	X	4.76	66.98	16.56	0.00	150.0	± 9.6 %
		Y	4.53	66.89	16.29		150.0	
		Z	4.48	67.27	16.46		150.0	
10194-CAB	IEEE 802.11n (HT Greenfield, 39 Mbps, 16-QAM)	X	4.98	67.40	16.66	0.00	150.0	± 9.6 %
		Y	4.70	67.19	16.42		150.0	
		Z	4.63	67.53	16.59		150.0	
10195-CAB	IEEE 802.11n (HT Greenfield, 65 Mbps, 64-QAM)	X	5.02	67.38	16.65	0.00	150.0	± 9.6 %
		Y	4.74	67.22	16.44		150.0	
		Z	4.67	67.55	16.61		150.0	
10196-CAB	IEEE 802.11n (HT Mixed, 6.5 Mbps, BPSK)	X	4.79	67.12	16.61	0.00	150.0	± 9.6 %
		Y	4.53	66.94	16.30		150.0	
		Z	4.47	67.29	16.46		150.0	
10197-CAB	IEEE 802.11n (HT Mixed, 39 Mbps, 16-QAM)	X	5.00	67.41	16.67	0.00	150.0	± 9.6 %
		Y	4.71	67.21	16.43		150.0	
		Z	4.64	67.54	16.60		150.0	
10198-CAB	IEEE 802.11n (HT Mixed, 65 Mbps, 64-QAM)	X	5.02	67.39	16.66	0.00	150.0	± 9.6 %
		Y	4.74	67.23	16.45		150.0	
		Z	4.67	67.55	16.61		150.0	
10219-CAB	IEEE 802.11n (HT Mixed, 7.2 Mbps, BPSK)	X	4.75	67.15	16.58	0.00	150.0	± 9.6 %
		Y	4.48	66.96	16.27		150.0	
		Z	4.43	67.33	16.43		150.0	
10220-CAB	IEEE 802.11n (HT Mixed, 43.3 Mbps, 16-QAM)	X	5.00	67.42	16.67	0.00	150.0	± 9.6 %
		Y	4.70	67.17	16.42		150.0	
		Z	4.63	67.50	16.58		150.0	
10221-CAB	IEEE 802.11n (HT Mixed, 72.2 Mbps, 64-QAM)	X	5.03	67.33	16.65	0.00	150.0	± 9.6 %
		Y	4.75	67.16	16.44		150.0	
		Z	4.68	67.49	16.60		150.0	
10222-CAB	IEEE 802.11n (HT Mixed, 15 Mbps, BPSK)	X	5.32	67.70	16.79	0.00	150.0	± 9.6 %
		Y	5.10	67.32	16.56		150.0	
		Z	5.04	67.57	16.71		150.0	

10223-CAB	IEEE 802.11n (HT Mixed, 90 Mbps, 16-QAM)	X	5.69	67.90	16.90	0.00	150.0	± 9.6 %
		Y	5.41	67.62	16.73		150.0	
		Z	5.32	67.79	16.83		150.0	
10224-CAB	IEEE 802.11n (HT Mixed, 150 Mbps, 64-QAM)	X	5.40	67.86	16.79	0.00	150.0	± 9.6 %
		Y	5.14	67.44	16.54		150.0	
		Z	5.08	67.68	16.69		150.0	
10225-CAB	UMTS-FDD (HSPA+)	X	3.04	66.91	16.27	0.00	150.0	± 9.6 %
		Y	2.80	66.45	15.40		150.0	
		Z	2.79	67.13	15.62		150.0	
10226-CAA	LTE-TDD (SC-FDMA, 1 RB, 1.4 MHz, 16-QAM)	X	19.62	92.68	26.54	6.02	65.0	± 9.6 %
		Y	28.14	106.53	31.60		65.0	
		Z	30.74	110.09	32.63		65.0	
10227-CAA	LTE-TDD (SC-FDMA, 1 RB, 1.4 MHz, 64-QAM)	X	17.31	89.65	25.20	6.02	65.0	± 9.6 %
		Y	25.62	103.45	30.17		65.0	
		Z	27.71	106.63	31.05		65.0	
10228-CAA	LTE-TDD (SC-FDMA, 1 RB, 1.4 MHz, QPSK)	X	25.12	101.14	30.46	6.02	65.0	± 9.6 %
		Y	22.85	107.40	33.58		65.0	
		Z	23.56	110.42	34.69		65.0	
10229-CAB	LTE-TDD (SC-FDMA, 1 RB, 3 MHz, 16-QAM)	X	19.21	92.22	26.33	6.02	65.0	± 9.6 %
		Y	26.37	105.18	31.14		65.0	
		Z	28.56	108.58	32.13		65.0	
10230-CAB	LTE-TDD (SC-FDMA, 1 RB, 3 MHz, 64-QAM)	X	16.99	89.27	25.02	6.02	65.0	± 9.6 %
		Y	24.08	102.25	29.76		65.0	
		Z	25.76	105.25	30.60		65.0	
10231-CAB	LTE-TDD (SC-FDMA, 1 RB, 3 MHz, QPSK)	X	24.47	100.57	30.23	6.02	65.0	± 9.6 %
		Y	21.54	106.10	33.13		65.0	
		Z	22.10	109.02	34.22		65.0	
10232-CAD	LTE-TDD (SC-FDMA, 1 RB, 5 MHz, 16-QAM)	X	19.21	92.23	26.33	6.02	65.0	± 9.6 %
		Y	26.35	105.17	31.13		65.0	
		Z	28.56	108.59	32.14		65.0	
10233-CAD	LTE-TDD (SC-FDMA, 1 RB, 5 MHz, 64-QAM)	X	16.99	89.29	25.03	6.02	65.0	± 9.6 %
		Y	24.05	102.24	29.76		65.0	
		Z	25.73	105.25	30.60		65.0	
10234-CAD	LTE-TDD (SC-FDMA, 1 RB, 5 MHz, QPSK)	X	23.75	99.87	29.94	6.02	65.0	± 9.6 %
		Y	20.44	104.88	32.66		65.0	
		Z	20.94	107.73	33.73		65.0	
10235-CAD	LTE-TDD (SC-FDMA, 1 RB, 10 MHz, 16-QAM)	X	19.23	92.26	26.34	6.02	65.0	± 9.6 %
		Y	26.43	105.24	31.16		65.0	
		Z	28.68	108.68	32.16		65.0	
10236-CAD	LTE-TDD (SC-FDMA, 1 RB, 10 MHz, 64-QAM)	X	17.05	89.34	25.04	6.02	65.0	± 9.6 %
		Y	24.28	102.38	29.79		65.0	
		Z	26.05	105.43	30.64		65.0	
10237-CAD	LTE-TDD (SC-FDMA, 1 RB, 10 MHz, QPSK)	X	24.65	100.72	30.28	6.02	65.0	± 9.6 %
		Y	21.67	106.26	33.17		65.0	
		Z	22.28	109.22	34.28		65.0	
10238-CAD	LTE-TDD (SC-FDMA, 1 RB, 15 MHz, 16-QAM)	X	19.21	92.24	26.33	6.02	65.0	± 9.6 %
		Y	26.34	105.18	31.13		65.0	
		Z	28.55	108.60	32.14		65.0	

10239-CAD	LTE-TDD (SC-FDMA, 1 RB, 15 MHz, 64-QAM)	X	17.00	89.31	25.04	6.02	65.0	± 9.6 %
		Y	24.00	102.22	29.75		65.0	
		Z	25.68	105.23	30.60		65.0	
10240-CAD	LTE-TDD (SC-FDMA, 1 RB, 15 MHz, QPSK)	X	24.60	100.69	30.26	6.02	65.0	± 9.6 %
		Y	21.61	106.21	33.16		65.0	
		Z	22.24	109.18	34.27		65.0	
10241-CAA	LTE-TDD (SC-FDMA, 50% RB, 1.4 MHz, 16-QAM)	X	14.83	87.15	27.43	6.98	65.0	± 9.6 %
		Y	11.87	87.25	27.69		65.0	
		Z	12.27	89.81	28.71		65.0	
10242-CAA	LTE-TDD (SC-FDMA, 50% RB, 1.4 MHz, 64-QAM)	X	14.03	85.86	26.85	6.98	65.0	± 9.6 %
		Y	11.07	85.73	27.03		65.0	
		Z	11.88	89.15	28.39		65.0	
10243-CAA	LTE-TDD (SC-FDMA, 50% RB, 1.4 MHz, QPSK)	X	12.50	85.61	27.61	6.98	65.0	± 9.6 %
		Y	8.91	82.53	26.67		65.0	
		Z	9.40	85.62	28.06		65.0	
10244-CAB	LTE-TDD (SC-FDMA, 50% RB, 3 MHz, 16-QAM)	X	10.84	80.28	21.46	3.98	65.0	± 9.6 %
		Y	8.60	79.06	19.82		65.0	
		Z	7.30	76.79	18.14		65.0	
10245-CAB	LTE-TDD (SC-FDMA, 50% RB, 3 MHz, 64-QAM)	X	10.80	80.00	21.33	3.98	65.0	± 9.6 %
		Y	8.32	78.30	19.47		65.0	
		Z	7.01	75.95	17.75		65.0	
10246-CAB	LTE-TDD (SC-FDMA, 50% RB, 3 MHz, QPSK)	X	10.19	81.67	21.72	3.98	65.0	± 9.6 %
		Y	9.19	82.92	21.40		65.0	
		Z	10.28	85.26	21.82		65.0	
10247-CAD	LTE-TDD (SC-FDMA, 50% RB, 5 MHz, 16-QAM)	X	9.24	78.33	20.99	3.98	65.0	± 9.6 %
		Y	7.42	77.41	19.87		65.0	
		Z	7.44	78.18	19.81		65.0	
10248-CAD	LTE-TDD (SC-FDMA, 50% RB, 5 MHz, 64-QAM)	X	9.29	78.02	20.88	3.98	65.0	± 9.6 %
		Y	7.28	76.69	19.57		65.0	
		Z	7.17	77.21	19.40		65.0	
10249-CAD	LTE-TDD (SC-FDMA, 50% RB, 5 MHz, QPSK)	X	10.52	82.18	22.29	3.98	65.0	± 9.6 %
		Y	10.94	86.37	23.51		65.0	
		Z	13.59	90.89	24.82		65.0	
10250-CAD	LTE-TDD (SC-FDMA, 50% RB, 10 MHz, 16-QAM)	X	9.84	79.38	22.27	3.98	65.0	± 9.6 %
		Y	8.59	80.24	22.59		65.0	
		Z	8.91	81.95	23.17		65.0	
10251-CAD	LTE-TDD (SC-FDMA, 50% RB, 10 MHz, 64-QAM)	X	9.48	77.77	21.45	3.98	65.0	± 9.6 %
		Y	7.96	77.76	21.28		65.0	
		Z	8.06	79.03	21.69		65.0	
10252-CAD	LTE-TDD (SC-FDMA, 50% RB, 10 MHz, QPSK)	X	10.35	81.23	22.32	3.98	65.0	± 9.6 %
		Y	10.67	85.75	24.25		65.0	
		Z	12.80	90.26	25.85		65.0	
10253-CAD	LTE-TDD (SC-FDMA, 50% RB, 15 MHz, 16-QAM)	X	9.41	77.10	21.37	3.98	65.0	± 9.6 %
		Y	7.89	76.83	21.30		65.0	
		Z	7.98	78.11	21.82		65.0	
10254-CAD	LTE-TDD (SC-FDMA, 50% RB, 15 MHz, 64-QAM)	X	9.73	77.64	21.86	3.98	65.0	± 9.6 %
		Y	8.31	77.74	21.96		65.0	
		Z	8.42	79.03	22.48		65.0	

10255-CAD	LTE-TDD (SC-FDMA, 50% RB, 15 MHz, QPSK)	X	9.76	78.98	21.63	3.98	65.0	± 9.6 %
		Y	9.21	81.58	22.99		65.0	
		Z	10.10	84.50	24.17		65.0	
10256-CAA	LTE-TDD (SC-FDMA, 100% RB, 1.4 MHz, 16-QAM)	X	10.36	79.33	20.55	3.98	65.0	± 9.6 %
		Y	6.89	75.10	17.29		65.0	
		Z	5.38	71.84	15.02		65.0	
10257-CAA	LTE-TDD (SC-FDMA, 100% RB, 1.4 MHz, 64-QAM)	X	10.33	78.98	20.36	3.98	65.0	± 9.6 %
		Y	6.60	74.15	16.79		65.0	
		Z	5.14	70.90	14.50		65.0	
10258-CAA	LTE-TDD (SC-FDMA, 100% RB, 1.4 MHz, QPSK)	X	9.84	80.89	21.06	3.98	65.0	± 9.6 %
		Y	6.93	77.80	18.67		65.0	
		Z	6.67	77.68	18.06		65.0	
10259-CAB	LTE-TDD (SC-FDMA, 100% RB, 3 MHz, 16-QAM)	X	9.48	78.65	21.42	3.98	65.0	± 9.6 %
		Y	7.89	78.48	20.85		65.0	
		Z	8.05	79.67	21.05		65.0	
10260-CAB	LTE-TDD (SC-FDMA, 100% RB, 3 MHz, 64-QAM)	X	9.52	78.48	21.39	3.98	65.0	± 9.6 %
		Y	7.84	78.08	20.70		65.0	
		Z	7.93	79.11	20.83		65.0	
10261-CAB	LTE-TDD (SC-FDMA, 100% RB, 3 MHz, QPSK)	X	10.28	81.56	22.27	3.98	65.0	± 9.6 %
		Y	10.28	85.25	23.51		65.0	
		Z	12.40	89.51	24.85		65.0	
10262-CAD	LTE-TDD (SC-FDMA, 100% RB, 5 MHz, 16-QAM)	X	9.83	79.35	22.25	3.98	65.0	± 9.6 %
		Y	8.56	80.18	22.55		65.0	
		Z	8.88	81.87	23.12		65.0	
10263-CAD	LTE-TDD (SC-FDMA, 100% RB, 5 MHz, 64-QAM)	X	9.48	77.78	21.46	3.98	65.0	± 9.6 %
		Y	7.94	77.74	21.28		65.0	
		Z	8.05	79.01	21.68		65.0	
10264-CAD	LTE-TDD (SC-FDMA, 100% RB, 5 MHz, QPSK)	X	10.32	81.15	22.28	3.98	65.0	± 9.6 %
		Y	10.57	85.55	24.15		65.0	
		Z	12.63	90.00	25.74		65.0	
10265-CAD	LTE-TDD (SC-FDMA, 100% RB, 10 MHz, 16-QAM)	X	9.59	77.50	21.45	3.98	65.0	± 9.6 %
		Y	8.04	77.33	21.54		65.0	
		Z	8.14	78.63	22.11		65.0	
10266-CAD	LTE-TDD (SC-FDMA, 100% RB, 10 MHz, 64-QAM)	X	9.89	78.01	21.96	3.98	65.0	± 9.6 %
		Y	8.50	78.31	22.27		65.0	
		Z	8.64	79.67	22.86		65.0	
10267-CAD	LTE-TDD (SC-FDMA, 100% RB, 10 MHz, QPSK)	X	9.88	78.96	21.38	3.98	65.0	± 9.6 %
		Y	9.52	81.96	22.96		65.0	
		Z	10.50	84.95	24.19		65.0	
10268-CAD	LTE-TDD (SC-FDMA, 100% RB, 15 MHz, 16-QAM)	X	9.95	76.96	21.54	3.98	65.0	± 9.6 %
		Y	8.52	76.88	21.79		65.0	
		Z	8.53	77.92	22.30		65.0	
10269-CAD	LTE-TDD (SC-FDMA, 100% RB, 15 MHz, 64-QAM)	X	9.89	76.68	21.52	3.98	65.0	± 9.6 %
		Y	8.46	76.46	21.67		65.0	
		Z	8.45	77.44	22.15		65.0	
10270-CAD	LTE-TDD (SC-FDMA, 100% RB, 15 MHz, QPSK)	X	9.66	77.24	20.86	3.98	65.0	± 9.6 %
		Y	8.81	78.78	21.90		65.0	
		Z	9.16	80.58	22.73		65.0	

10274-CAB	UMTS-FDD (HSUPA, Subtest 5, 3GPP Rel8.10)	X	2.74	67.26	16.17	0.00	150.0	± 9.6 %
		Y	2.61	66.92	15.38		150.0	
		Z	2.66	67.94	15.80		150.0	
10275-CAB	UMTS-FDD (HSUPA, Subtest 5, 3GPP Rel8.4)	X	2.05	72.21	18.03	0.00	150.0	± 9.6 %
		Y	1.65	68.50	15.87		150.0	
		Z	1.80	70.74	17.08		150.0	
10277-CAA	PHS (QPSK)	X	8.03	72.61	16.76	9.03	50.0	± 9.6 %
		Y	5.31	69.07	13.45		50.0	
		Z	4.52	67.70	12.08		50.0	
10278-CAA	PHS (QPSK, BW 884MHz, Rolloff 0.5)	X	10.53	79.27	21.29	9.03	50.0	± 9.6 %
		Y	8.21	77.64	19.35		50.0	
		Z	7.62	76.93	18.36		50.0	
10279-CAA	PHS (QPSK, BW 884MHz, Rolloff 0.38)	X	10.71	79.48	21.37	9.03	50.0	± 9.6 %
		Y	8.29	77.74	19.41		50.0	
		Z	7.68	77.01	18.42		50.0	
10290-AAB	CDMA2000, RC1, SO55, Full Rate	X	2.46	75.92	18.53	0.00	150.0	± 9.6 %
		Y	1.45	69.17	13.90		150.0	
		Z	1.74	72.52	15.01		150.0	
10291-AAB	CDMA2000, RC3, SO55, Full Rate	X	1.54	75.02	18.13	0.00	150.0	± 9.6 %
		Y	0.85	66.46	12.55		150.0	
		Z	1.09	70.54	14.22		150.0	
10292-AAB	CDMA2000, RC3, SO32, Full Rate	X	2.85	86.00	22.76	0.00	150.0	± 9.6 %
		Y	1.20	72.00	15.52		150.0	
		Z	3.37	86.48	20.58		150.0	
10293-AAB	CDMA2000, RC3, SO3, Full Rate	X	6.08	98.98	27.50	0.00	150.0	± 9.6 %
		Y	2.38	81.80	19.81		150.0	
		Z	91.77	132.75	32.89		150.0	
10295-AAB	CDMA2000, RC1, SO3, 1/8th Rate 25 fr.	X	11.42	82.00	23.75	9.03	50.0	± 9.6 %
		Y	13.54	88.04	25.23		50.0	
		Z	20.14	95.71	27.34		50.0	
10297-AAC	LTE-FDD (SC-FDMA, 50% RB, 20 MHz, QPSK)	X	3.39	72.81	18.09	0.00	150.0	± 9.6 %
		Y	2.76	70.00	16.84		150.0	
		Z	2.84	71.20	17.58		150.0	
10298-AAC	LTE-FDD (SC-FDMA, 50% RB, 3 MHz, QPSK)	X	2.33	72.89	17.78	0.00	150.0	± 9.6 %
		Y	1.54	67.89	13.96		150.0	
		Z	1.61	69.51	14.40		150.0	
10299-AAC	LTE-FDD (SC-FDMA, 50% RB, 3 MHz, 16-QAM)	X	4.61	76.96	19.19	0.00	150.0	± 9.6 %
		Y	2.70	70.48	14.61		150.0	
		Z	1.96	66.96	12.10		150.0	
10300-AAC	LTE-FDD (SC-FDMA, 50% RB, 3 MHz, 64-QAM)	X	3.49	71.59	16.26	0.00	150.0	± 9.6 %
		Y	1.91	65.24	11.36		150.0	
		Z	1.47	63.13	9.40		150.0	
10301-AAA	IEEE 802.16e WiMAX (29:18, 5ms, 10MHz, QPSK, PUSC)	X	6.59	70.34	20.04	4.17	80.0	± 9.6 %
		Y	5.68	68.74	18.85		80.0	
		Z	5.70	69.67	19.26		80.0	
10302-AAA	IEEE 802.16e WiMAX (29:18, 5ms, 10MHz, QPSK, PUSC, 3 CTRL symbols)	X	7.28	71.73	21.22	4.96	80.0	± 9.6 %
		Y	6.10	69.04	19.43		80.0	
		Z	6.04	69.77	19.77		80.0	

10303-AAA	IEEE 802.16e WiMAX (31:15, 5ms, 10MHz, 64QAM, PUSC)	X	7.35	72.51	21.62	4.96	80.0	± 9.6 %
		Y	5.94	69.06	19.41		80.0	
		Z	5.89	69.82	19.76		80.0	
10304-AAA	IEEE 802.16e WiMAX (29:18, 5ms, 10MHz, 64QAM, PUSC)	X	6.69	70.97	20.39	4.17	80.0	± 9.6 %
		Y	5.59	68.42	18.66		80.0	
		Z	5.56	69.20	19.00		80.0	
10305-AAA	IEEE 802.16e WiMAX (31:15, 10ms, 10MHz, 64QAM, PUSC, 15 symbols)	X	14.75	90.64	29.58	6.02	50.0	± 9.6 %
		Y	10.18	84.38	26.41		50.0	
		Z	10.30	85.54	26.72		50.0	
10306-AAA	IEEE 802.16e WiMAX (29:18, 10ms, 10MHz, 64QAM, PUSC, 18 symbols)	X	9.44	79.58	25.56	6.02	50.0	± 9.6 %
		Y	7.33	75.98	23.40		50.0	
		Z	6.44	73.04	21.64		50.0	
10307-AAA	IEEE 802.16e WiMAX (29:18, 10ms, 10MHz, QPSK, PUSC, 18 symbols)	X	10.22	81.50	26.08	6.02	50.0	± 9.6 %
		Y	7.67	77.32	23.80		50.0	
		Z	7.49	77.77	23.93		50.0	
10308-AAA	IEEE 802.16e WiMAX (29:18, 10ms, 10MHz, 16QAM, PUSC)	X	10.67	82.66	26.55	6.02	50.0	± 9.6 %
		Y	7.93	78.29	24.23		50.0	
		Z	7.77	78.85	24.42		50.0	
10309-AAA	IEEE 802.16e WiMAX (29:18, 10ms, 10MHz, 16QAM, AMC 2x3, 18 symbols)	X	9.59	79.83	25.67	6.02	50.0	± 9.6 %
		Y	7.43	76.26	23.57		50.0	
		Z	6.50	73.23	21.79		50.0	
10310-AAA	IEEE 802.16e WiMAX (29:18, 10ms, 10MHz, QPSK, AMC 2x3, 18 symbols)	X	9.69	80.24	25.70	6.02	50.0	± 9.6 %
		Y	7.48	76.59	23.59		50.0	
		Z	7.35	77.19	23.79		50.0	
10311-AAC	LTE-FDD (SC-FDMA, 100% RB, 15 MHz, QPSK)	X	3.76	71.88	17.62	0.00	150.0	± 9.6 %
		Y	3.12	69.22	16.46		150.0	
		Z	3.20	70.27	17.11		150.0	
10313-AAA	IDEN 1:3	X	8.04	75.55	17.71	6.99	70.0	± 9.6 %
		Y	8.89	81.65	20.17		70.0	
		Z	12.54	87.83	22.26		70.0	
10314-AAA	IDEN 1:6	X	10.06	79.94	21.38	10.00	30.0	± 9.6 %
		Y	12.66	89.89	25.48		30.0	
		Z	20.06	99.62	28.65		30.0	
10315-AAB	IEEE 802.11b WiFi 2.4 GHz (DSSS, 1 Mbps, 96pc duty cycle)	X	1.30	67.68	17.69	0.17	150.0	± 9.6 %
		Y	1.18	64.90	15.80		150.0	
		Z	1.23	65.94	16.59		150.0	
10316-AAB	IEEE 802.11g WiFi 2.4 GHz (ERP-OFDM, 6 Mbps, 96pc duty cycle)	X	4.90	67.26	16.78	0.17	150.0	± 9.6 %
		Y	4.64	67.10	16.54		150.0	
		Z	4.58	67.43	16.69		150.0	
10317-AAB	IEEE 802.11a WiFi 5 GHz (OFDM, 6 Mbps, 96pc duty cycle)	X	4.90	67.26	16.78	0.17	150.0	± 9.6 %
		Y	4.64	67.10	16.54		150.0	
		Z	4.58	67.43	16.69		150.0	
10400-AAC	IEEE 802.11ac WiFi (20MHz, 64-QAM, 99pc duty cycle)	X	5.01	67.47	16.66	0.00	150.0	± 9.6 %
		Y	4.68	67.24	16.42		150.0	
		Z	4.61	67.58	16.60		150.0	
10401-AAC	IEEE 802.11ac WiFi (40MHz, 64-QAM, 99pc duty cycle)	X	5.58	67.43	16.66	0.00	150.0	± 9.6 %
		Y	5.46	67.62	16.70		150.0	
		Z	5.29	67.47	16.64		150.0	

10402-AAC	IEEE 802.11ac WiFi (80MHz, 64-QAM, 99pc duty cycle)	X	5.90	68.07	16.80	0.00	150.0	± 9.6 %
		Y	5.66	67.67	16.59		150.0	
		Z	5.60	67.87	16.71		150.0	
10403-AAB	CDMA2000 (1xEV-DO, Rev. 0)	X	2.46	75.92	18.53	0.00	115.0	± 9.6 %
		Y	1.45	69.17	13.90		115.0	
		Z	1.74	72.52	15.01		115.0	
10404-AAB	CDMA2000 (1xEV-DO, Rev. A)	X	2.46	75.92	18.53	0.00	115.0	± 9.6 %
		Y	1.45	69.17	13.90		115.0	
		Z	1.74	72.52	15.01		115.0	
10406-AAB	CDMA2000, RC3, SO32, SCH0, Full Rate	X	38.96	111.40	30.01	0.00	100.0	± 9.6 %
		Y	96.63	125.46	32.24		100.0	
		Z	100.00	123.89	30.87		100.0	
10410-AAC	LTE-TDD (SC-FDMA, 1 RB, 10 MHz, QPSK, UL Subframe=2,3,4,7,8,9)	X	79.33	113.95	29.40	3.23	80.0	± 9.6 %
		Y	100.00	123.80	32.02		80.0	
		Z	100.00	124.20	31.74		80.0	
10415-AAA	IEEE 802.11b WiFi 2.4 GHz (DSSS, 1 Mbps, 99pc duty cycle)	X	1.01	64.64	16.23	0.00	150.0	± 9.6 %
		Y	1.03	63.36	14.90		150.0	
		Z	1.08	64.37	15.69		150.0	
10416-AAA	IEEE 802.11g WiFi 2.4 GHz (ERP-OFDM, 6 Mbps, 99pc duty cycle)	X	4.76	67.00	16.58	0.00	150.0	± 9.6 %
		Y	4.53	66.92	16.37		150.0	
		Z	4.48	67.28	16.53		150.0	
10417-AAA	IEEE 802.11a/h WiFi 5 GHz (OFDM, 6 Mbps, 99pc duty cycle)	X	4.76	67.00	16.58	0.00	150.0	± 9.6 %
		Y	4.53	66.92	16.37		150.0	
		Z	4.48	67.28	16.53		150.0	
10418-AAA	IEEE 802.11g WiFi 2.4 GHz (DSSS-OFDM, 6 Mbps, 99pc duty cycle, Long preamble)	X	4.74	67.14	16.57	0.00	150.0	± 9.6 %
		Y	4.53	67.10	16.40		150.0	
		Z	4.48	67.49	16.59		150.0	
10419-AAA	IEEE 802.11g WiFi 2.4 GHz (DSSS-OFDM, 6 Mbps, 99pc duty cycle, Short preamble)	X	4.77	67.10	16.59	0.00	150.0	± 9.6 %
		Y	4.55	67.04	16.39		150.0	
		Z	4.49	67.42	16.58		150.0	
10422-AAA	IEEE 802.11n (HT Greenfield, 7.2 Mbps, BPSK)	X	4.90	67.10	16.59	0.00	150.0	± 9.6 %
		Y	4.66	67.03	16.41		150.0	
		Z	4.60	67.38	16.58		150.0	
10423-AAA	IEEE 802.11n (HT Greenfield, 43.3 Mbps, 16-QAM)	X	5.14	67.54	16.75	0.00	150.0	± 9.6 %
		Y	4.81	67.33	16.51		150.0	
		Z	4.74	67.65	16.67		150.0	
10424-AAA	IEEE 802.11n (HT Greenfield, 72.2 Mbps, 64-QAM)	X	5.04	67.47	16.71	0.00	150.0	± 9.6 %
		Y	4.74	67.28	16.49		150.0	
		Z	4.66	67.61	16.65		150.0	
10425-AAA	IEEE 802.11n (HT Greenfield, 15 Mbps, BPSK)	X	5.61	67.86	16.86	0.00	150.0	± 9.6 %
		Y	5.36	67.59	16.69		150.0	
		Z	5.29	67.80	16.81		150.0	
10426-AAA	IEEE 802.11n (HT Greenfield, 90 Mbps, 16-QAM)	X	5.62	67.87	16.86	0.00	150.0	± 9.6 %
		Y	5.40	67.74	16.76		150.0	
		Z	5.31	67.91	16.86		150.0	

10427-AAA	IEEE 802.11n (HT Greenfield, 150 Mbps, 64-QAM)	X	5.65	67.92	16.88	0.00	150.0	± 9.6 %
		Y	5.39	67.63	16.70		150.0	
		Z	5.28	67.70	16.75		150.0	
10430-AAB	LTE-FDD (OFDMA, 5 MHz, E-TM 3.1)	X	4.50	70.33	18.46	0.00	150.0	± 9.6 %
		Y	4.28	71.46	18.38		150.0	
		Z	4.28	72.32	18.56		150.0	
10431-AAB	LTE-FDD (OFDMA, 10 MHz, E-TM 3.1)	X	4.56	67.66	16.75	0.00	150.0	± 9.6 %
		Y	4.19	67.51	16.33		150.0	
		Z	4.12	67.97	16.50		150.0	
10432-AAB	LTE-FDD (OFDMA, 15 MHz, E-TM 3.1)	X	4.83	67.55	16.72	0.00	150.0	± 9.6 %
		Y	4.50	67.35	16.43		150.0	
		Z	4.43	67.74	16.61		150.0	
10433-AAB	LTE-FDD (OFDMA, 20 MHz, E-TM 3.1)	X	5.06	67.54	16.75	0.00	150.0	± 9.6 %
		Y	4.75	67.32	16.51		150.0	
		Z	4.68	67.64	16.67		150.0	
10434-AAA	W-CDMA (BS Test Model 1, 64 DPCH)	X	4.58	70.97	18.48	0.00	150.0	± 9.6 %
		Y	4.39	72.38	18.32		150.0	
		Z	4.42	73.36	18.48		150.0	
10435-AAC	LTE-TDD (SC-FDMA, 1 RB, 20 MHz, QPSK, UL Subframe=2,3,4,7,8,9)	X	73.07	112.66	29.06	3.23	80.0	± 9.6 %
		Y	100.00	123.60	31.93		80.0	
		Z	100.00	123.98	31.64		80.0	
10447-AAB	LTE-FDD (OFDMA, 5 MHz, E-TM 3.1, Clipping 44%)	X	3.91	67.87	16.49	0.00	150.0	± 9.6 %
		Y	3.47	67.50	15.53		150.0	
		Z	3.41	68.08	15.62		150.0	
10448-AAB	LTE-FDD (OFDMA, 10 MHz, E-TM 3.1, Clipping 44%)	X	4.36	67.43	16.61	0.00	150.0	± 9.6 %
		Y	4.04	67.29	16.20		150.0	
		Z	3.99	67.77	16.38		150.0	
10449-AAB	LTE-FDD (OFDMA, 15 MHz, E-TM 3.1, Clipping 44%)	X	4.59	67.37	16.63	0.00	150.0	± 9.6 %
		Y	4.32	67.18	16.33		150.0	
		Z	4.27	67.58	16.51		150.0	
10450-AAB	LTE-FDD (OFDMA, 20 MHz, E-TM 3.1, Clipping 44%)	X	4.75	67.29	16.62	0.00	150.0	± 9.6 %
		Y	4.52	67.08	16.36		150.0	
		Z	4.47	67.43	16.54		150.0	
10451-AAA	W-CDMA (BS Test Model 1, 64 DPCH, Clipping 44%)	X	3.88	68.25	16.35	0.00	150.0	± 9.6 %
		Y	3.34	67.60	15.06		150.0	
		Z	3.25	68.08	15.03		150.0	
10456-AAA	IEEE 802.11ac WiFi (160MHz, 64-QAM, 99pc duty cycle)	X	6.45	68.48	17.01	0.00	150.0	± 9.6 %
		Y	6.28	68.20	16.88		150.0	
		Z	6.24	68.43	17.01		150.0	
10457-AAA	UMTS-FDD (DC-HSDPA)	X	3.87	65.68	16.38	0.00	150.0	± 9.6 %
		Y	3.81	65.57	16.07		150.0	
		Z	3.81	65.98	16.26		150.0	
10458-AAA	CDMA2000 (1xEV-DO, Rev. B, 2 carriers)	X	3.63	67.17	15.82	0.00	150.0	± 9.6 %
		Y	3.13	66.82	14.32		150.0	
		Z	2.97	66.93	13.99		150.0	
10459-AAA	CDMA2000 (1xEV-DO, Rev. B, 3 carriers)	X	4.79	65.36	16.37	0.00	150.0	± 9.6 %
		Y	4.24	65.27	15.46		150.0	
		Z	4.13	65.72	15.38		150.0	

10460-AAA	UMTS-FDD (WCDMA, AMR)	X	1.54	79.74	21.99	0.00	150.0	± 9.6 %
		Y	0.95	69.06	16.64		150.0	
		Z	1.16	73.20	19.00		150.0	
10461-AAA	LTE-TDD (SC-FDMA, 1 RB, 1.4 MHz, QPSK, UL Subframe=2,3,4,7,8,9)	X	100.00	118.00	30.59	3.29	80.0	± 9.6 %
		Y	100.00	127.27	33.69		80.0	
		Z	100.00	128.13	33.61		80.0	
10462-AAA	LTE-TDD (SC-FDMA, 1 RB, 1.4 MHz, 16-QAM, UL Subframe=2,3,4,7,8,9)	X	100.00	108.76	26.18	3.23	80.0	± 9.6 %
		Y	100.00	111.69	26.26		80.0	
		Z	100.00	109.78	24.92		80.0	
10463-AAA	LTE-TDD (SC-FDMA, 1 RB, 1.4 MHz, 64-QAM, UL Subframe=2,3,4,7,8,9)	X	61.06	101.21	23.94	3.23	80.0	± 9.6 %
		Y	100.00	108.45	24.70		80.0	
		Z	9.38	82.48	17.38		80.0	
10464-AAA	LTE-TDD (SC-FDMA, 1 RB, 3 MHz, QPSK, UL Subframe=2,3,4,7,8,9)	X	100.00	116.66	29.84	3.23	80.0	± 9.6 %
		Y	100.00	125.35	32.64		80.0	
		Z	100.00	125.94	32.43		80.0	
10465-AAA	LTE-TDD (SC-FDMA, 1 RB, 3 MHz, 16-QAM, UL Subframe=2,3,4,7,8,9)	X	100.00	108.47	26.02	3.23	80.0	± 9.6 %
		Y	100.00	111.17	26.01		80.0	
		Z	44.16	100.58	22.73		80.0	
10466-AAA	LTE-TDD (SC-FDMA, 1 RB, 3 MHz, 64-QAM, UL Subframe=2,3,4,7,8,9)	X	42.58	96.75	22.75	3.23	80.0	± 9.6 %
		Y	42.99	98.93	22.41		80.0	
		Z	5.89	77.61	15.84		80.0	
10467-AAC	LTE-TDD (SC-FDMA, 1 RB, 5 MHz, QPSK, UL Subframe=2,3,4,7,8,9)	X	100.00	116.79	29.90	3.23	80.0	± 9.6 %
		Y	100.00	125.60	32.75		80.0	
		Z	100.00	126.22	32.56		80.0	
10468-AAC	LTE-TDD (SC-FDMA, 1 RB, 5 MHz, 16-QAM, UL Subframe=2,3,4,7,8,9)	X	100.00	108.56	26.07	3.23	80.0	± 9.6 %
		Y	100.00	111.35	26.09		80.0	
		Z	61.74	104.33	23.64		80.0	
10469-AAC	LTE-TDD (SC-FDMA, 1 RB, 5 MHz, 64-QAM, UL Subframe=2,3,4,7,8,9)	X	43.83	97.08	22.83	3.23	80.0	± 9.6 %
		Y	46.06	99.70	22.59		80.0	
		Z	6.04	77.89	15.93		80.0	
10470-AAC	LTE-TDD (SC-FDMA, 1 RB, 10 MHz, QPSK, UL Subframe=2,3,4,7,8,9)	X	100.00	116.81	29.90	3.23	80.0	± 9.6 %
		Y	100.00	125.63	32.76		80.0	
		Z	100.00	126.25	32.56		80.0	
10471-AAC	LTE-TDD (SC-FDMA, 1 RB, 10 MHz, 16-QAM, UL Subframe=2,3,4,7,8,9)	X	100.00	108.53	26.05	3.23	80.0	± 9.6 %
		Y	100.00	111.31	26.07		80.0	
		Z	61.64	104.26	23.61		80.0	
10472-AAC	LTE-TDD (SC-FDMA, 1 RB, 10 MHz, 64-QAM, UL Subframe=2,3,4,7,8,9)	X	44.10	97.14	22.84	3.23	80.0	± 9.6 %
		Y	46.39	99.73	22.59		80.0	
		Z	6.02	77.83	15.90		80.0	
10473-AAC	LTE-TDD (SC-FDMA, 1 RB, 15 MHz, QPSK, UL Subframe=2,3,4,7,8,9)	X	100.00	116.79	29.89	3.23	80.0	± 9.6 %
		Y	100.00	125.60	32.74		80.0	
		Z	100.00	126.23	32.55		80.0	
10474-AAC	LTE-TDD (SC-FDMA, 1 RB, 15 MHz, 16-QAM, UL Subframe=2,3,4,7,8,9)	X	100.00	108.54	26.05	3.23	80.0	± 9.6 %
		Y	100.00	111.32	26.07		80.0	
		Z	60.20	104.02	23.55		80.0	
10475-AAC	LTE-TDD (SC-FDMA, 1 RB, 15 MHz, 64-QAM, UL Subframe=2,3,4,7,8,9)	X	43.66	97.03	22.81	3.23	80.0	± 9.6 %
		Y	44.87	99.39	22.51		80.0	
		Z	5.94	77.72	15.87		80.0	

10477-AAC	LTE-TDD (SC-FDMA, 1 RB, 20 MHz, 16-QAM, UL Subframe=2,3,4,7,8,9)	X	100.00	108.43	26.00	3.23	80.0	± 9.6 %
		Y	100.00	111.14	25.99		80.0	
		Z	48.11	101.47	22.92		80.0	
10478-AAC	LTE-TDD (SC-FDMA, 1 RB, 20 MHz, 64-QAM, UL Subframe=2,3,4,7,8,9)	X	43.04	96.84	22.76	3.23	80.0	± 9.6 %
		Y	43.24	98.94	22.39		80.0	
		Z	5.86	77.55	15.80		80.0	
10479-AAA	LTE-TDD (SC-FDMA, 50% RB, 1.4 MHz, QPSK, UL Subframe=2,3,4,7,8,9)	X	18.43	95.26	26.62	3.23	80.0	± 9.6 %
		Y	47.63	113.17	30.89		80.0	
		Z	79.42	120.84	32.18		80.0	
10480-AAA	LTE-TDD (SC-FDMA, 50% RB, 1.4 MHz, 16-QAM, UL Subframe=2,3,4,7,8,9)	X	15.38	87.90	23.16	3.23	80.0	± 9.6 %
		Y	35.80	101.51	25.84		80.0	
		Z	33.10	99.76	24.57		80.0	
10481-AAA	LTE-TDD (SC-FDMA, 50% RB, 1.4 MHz, 64-QAM, UL Subframe=2,3,4,7,8,9)	X	14.20	86.14	22.35	3.23	80.0	± 9.6 %
		Y	23.64	94.76	23.60		80.0	
		Z	17.83	90.68	21.64		80.0	
10482-AAA	LTE-TDD (SC-FDMA, 50% RB, 3 MHz, QPSK, UL Subframe=2,3,4,7,8,9)	X	11.00	86.13	22.59	2.23	80.0	± 9.6 %
		Y	6.54	80.66	19.81		80.0	
		Z	10.00	86.91	21.46		80.0	
10483-AAA	LTE-TDD (SC-FDMA, 50% RB, 3 MHz, 16-QAM, UL Subframe=2,3,4,7,8,9)	X	11.81	84.53	22.26	2.23	80.0	± 9.6 %
		Y	9.59	82.56	20.08		80.0	
		Z	5.79	75.74	16.81		80.0	
10484-AAA	LTE-TDD (SC-FDMA, 50% RB, 3 MHz, 64-QAM, UL Subframe=2,3,4,7,8,9)	X	11.16	83.50	21.93	2.23	80.0	± 9.6 %
		Y	8.15	80.18	19.27		80.0	
		Z	5.05	73.86	16.10		80.0	
10485-AAC	LTE-TDD (SC-FDMA, 50% RB, 5 MHz, QPSK, UL Subframe=2,3,4,7,8,9)	X	11.03	86.44	23.15	2.23	80.0	± 9.6 %
		Y	6.87	82.16	21.41		80.0	
		Z	9.87	88.59	23.41		80.0	
10486-AAC	LTE-TDD (SC-FDMA, 50% RB, 5 MHz, 16-QAM, UL Subframe=2,3,4,7,8,9)	X	6.95	77.02	19.85	2.23	80.0	± 9.6 %
		Y	4.98	74.27	17.96		80.0	
		Z	5.53	76.50	18.48		80.0	
10487-AAC	LTE-TDD (SC-FDMA, 50% RB, 5 MHz, 64-QAM, UL Subframe=2,3,4,7,8,9)	X	6.82	76.43	19.65	2.23	80.0	± 9.6 %
		Y	4.85	73.54	17.65		80.0	
		Z	5.25	75.41	18.04		80.0	
10488-AAC	LTE-TDD (SC-FDMA, 50% RB, 10 MHz, QPSK, UL Subframe=2,3,4,7,8,9)	X	9.46	82.96	22.30	2.23	80.0	± 9.6 %
		Y	5.99	78.96	21.12		80.0	
		Z	6.82	82.33	22.47		80.0	
10489-AAC	LTE-TDD (SC-FDMA, 50% RB, 10 MHz, 16-QAM, UL Subframe=2,3,4,7,8,9)	X	6.62	75.52	19.96	2.23	80.0	± 9.6 %
		Y	4.91	73.20	18.90		80.0	
		Z	5.11	74.84	19.54		80.0	
10490-AAC	LTE-TDD (SC-FDMA, 50% RB, 10 MHz, 64-QAM, UL Subframe=2,3,4,7,8,9)	X	6.56	74.88	19.76	2.23	80.0	± 9.6 %
		Y	4.94	72.82	18.76		80.0	
		Z	5.10	74.33	19.33		80.0	
10491-AAC	LTE-TDD (SC-FDMA, 50% RB, 15 MHz, QPSK, UL Subframe=2,3,4,7,8,9)	X	7.98	78.75	20.93	2.23	80.0	± 9.6 %
		Y	5.56	75.73	20.09		80.0	
		Z	5.84	77.68	21.00		80.0	
10492-AAC	LTE-TDD (SC-FDMA, 50% RB, 15 MHz, 16-QAM, UL Subframe=2,3,4,7,8,9)	X	6.52	73.74	19.47	2.23	80.0	± 9.6 %
		Y	5.01	71.66	18.63		80.0	
		Z	5.04	72.68	19.10		80.0	

10493-AAC	LTE-TDD (SC-FDMA, 50% RB, 15 MHz, 64-QAM, UL Subframe=2,3,4,7,8,9)	X	6.52	73.38	19.36	2.23	80.0	± 9.6 %
		Y	5.05	71.42	18.55		80.0	
		Z	5.05	72.38	18.97		80.0	
10494-AAC	LTE-TDD (SC-FDMA, 50% RB, 20 MHz, QPSK, UL Subframe=2,3,4,7,8,9)	X	9.30	81.16	21.56	2.23	80.0	± 9.6 %
		Y	6.19	77.55	20.65		80.0	
		Z	6.63	79.81	21.68		80.0	
10495-AAC	LTE-TDD (SC-FDMA, 50% RB, 20 MHz, 16-QAM, UL Subframe=2,3,4,7,8,9)	X	6.75	74.54	19.74	2.23	80.0	± 9.6 %
		Y	5.09	72.10	18.86		80.0	
		Z	5.10	73.07	19.34		80.0	
10496-AAC	LTE-TDD (SC-FDMA, 50% RB, 20 MHz, 64-QAM, UL Subframe=2,3,4,7,8,9)	X	6.67	73.87	19.53	2.23	80.0	± 9.6 %
		Y	5.11	71.66	18.72		80.0	
		Z	5.11	72.57	19.16		80.0	
10497-AAA	LTE-TDD (SC-FDMA, 100% RB, 1.4 MHz, QPSK, UL Subframe=2,3,4,7,8,9)	X	9.58	84.00	21.43	2.23	80.0	± 9.6 %
		Y	4.27	74.12	16.39		80.0	
		Z	5.12	76.54	16.66		80.0	
10498-AAA	LTE-TDD (SC-FDMA, 100% RB, 1.4 MHz, 16-QAM, UL Subframe=2,3,4,7,8,9)	X	6.19	75.19	17.72	2.23	80.0	± 9.6 %
		Y	2.33	64.39	11.23		80.0	
		Z	1.83	62.54	9.68		80.0	
10499-AAA	LTE-TDD (SC-FDMA, 100% RB, 1.4 MHz, 64-QAM, UL Subframe=2,3,4,7,8,9)	X	6.08	74.60	17.40	2.23	80.0	± 9.6 %
		Y	2.20	63.55	10.68		80.0	
		Z	1.70	61.64	9.07		80.0	
10500-AAA	LTE-TDD (SC-FDMA, 100% RB, 3 MHz, QPSK, UL Subframe=2,3,4,7,8,9)	X	9.69	83.97	22.50	2.23	80.0	± 9.6 %
		Y	6.26	80.30	21.12		80.0	
		Z	7.99	85.23	22.80		80.0	
10501-AAA	LTE-TDD (SC-FDMA, 100% RB, 3 MHz, 16-QAM, UL Subframe=2,3,4,7,8,9)	X	6.73	76.14	19.79	2.23	80.0	± 9.6 %
		Y	4.97	73.89	18.33		80.0	
		Z	5.41	76.03	18.94		80.0	
10502-AAA	LTE-TDD (SC-FDMA, 100% RB, 3 MHz, 64-QAM, UL Subframe=2,3,4,7,8,9)	X	6.66	75.65	19.59	2.23	80.0	± 9.6 %
		Y	4.97	73.54	18.13		80.0	
		Z	5.36	75.51	18.67		80.0	
10503-AAC	LTE-TDD (SC-FDMA, 100% RB, 5 MHz, QPSK, UL Subframe=2,3,4,7,8,9)	X	9.33	82.74	22.21	2.23	80.0	± 9.6 %
		Y	5.90	78.70	21.01		80.0	
		Z	6.71	82.03	22.35		80.0	
10504-AAC	LTE-TDD (SC-FDMA, 100% RB, 5 MHz, 16-QAM, UL Subframe=2,3,4,7,8,9)	X	6.59	75.44	19.92	2.23	80.0	± 9.6 %
		Y	4.88	73.08	18.84		80.0	
		Z	5.07	74.71	19.47		80.0	
10505-AAC	LTE-TDD (SC-FDMA, 100% RB, 5 MHz, 64-QAM, UL Subframe=2,3,4,7,8,9)	X	6.52	74.79	19.72	2.23	80.0	± 9.6 %
		Y	4.91	72.71	18.70		80.0	
		Z	5.07	74.21	19.27		80.0	
10506-AAC	LTE-TDD (SC-FDMA, 100% RB, 10 MHz, QPSK, UL Subframe=2,3,4,7,8,9)	X	9.21	81.00	21.50	2.23	80.0	± 9.6 %
		Y	6.13	77.37	20.57		80.0	
		Z	6.56	79.62	21.60		80.0	
10507-AAC	LTE-TDD (SC-FDMA, 100% RB, 10 MHz, 16-QAM, UL Subframe=2,3,4,7,8,9)	X	6.72	74.48	19.71	2.23	80.0	± 9.6 %
		Y	5.07	72.03	18.82		80.0	
		Z	5.08	73.01	19.31		80.0	

10508-AAC	LTE-TDD (SC-FDMA, 100% RB, 10 MHz, 64-QAM, UL Subframe=2,3,4,7,8,9)	X	6.65	73.80	19.50	2.23	80.0	± 9.6 %
		Y	5.09	71.58	18.67		80.0	
		Z	5.09	72.48	19.12		80.0	
10509-AAC	LTE-TDD (SC-FDMA, 100% RB, 15 MHz, QPSK, UL Subframe=2,3,4,7,8,9)	X	8.15	77.43	20.26	2.23	80.0	± 9.6 %
		Y	5.99	74.82	19.62		80.0	
		Z	6.17	76.24	20.35		80.0	
10510-AAC	LTE-TDD (SC-FDMA, 100% RB, 15 MHz, 16-QAM, UL Subframe=2,3,4,7,8,9)	X	6.94	73.36	19.32	2.23	80.0	± 9.6 %
		Y	5.42	71.16	18.60		80.0	
		Z	5.37	71.81	18.97		80.0	
10511-AAC	LTE-TDD (SC-FDMA, 100% RB, 15 MHz, 64-QAM, UL Subframe=2,3,4,7,8,9)	X	6.87	72.87	19.19	2.23	80.0	± 9.6 %
		Y	5.44	70.83	18.50		80.0	
		Z	5.39	71.45	18.85		80.0	
10512-AAC	LTE-TDD (SC-FDMA, 100% RB, 20 MHz, QPSK, UL Subframe=2,3,4,7,8,9)	X	9.41	80.22	21.09	2.23	80.0	± 9.6 %
		Y	6.52	76.83	20.24		80.0	
		Z	6.84	78.58	21.10		80.0	
10513-AAC	LTE-TDD (SC-FDMA, 100% RB, 20 MHz, 16-QAM, UL Subframe=2,3,4,7,8,9)	X	7.03	74.19	19.61	2.23	80.0	± 9.6 %
		Y	5.36	71.56	18.76		80.0	
		Z	5.31	72.21	19.14		80.0	
10514-AAC	LTE-TDD (SC-FDMA, 100% RB, 20 MHz, 64-QAM, UL Subframe=2,3,4,7,8,9)	X	6.85	73.42	19.39	2.23	80.0	± 9.6 %
		Y	5.32	71.03	18.59		80.0	
		Z	5.27	71.61	18.94		80.0	
10515-AAA	IEEE 802.11b WiFi 2.4 GHz (DSSS, 2 Mbps, 99pc duty cycle)	X	0.98	65.05	16.44	0.00	150.0	± 9.6 %
		Y	1.00	63.56	14.97		150.0	
		Z	1.05	64.66	15.82		150.0	
10516-AAA	IEEE 802.11b WiFi 2.4 GHz (DSSS, 5.5 Mbps, 99pc duty cycle)	X	100.00	168.11	45.87	0.00	150.0	± 9.6 %
		Y	0.67	71.83	18.15		150.0	
		Z	1.04	80.65	22.82		150.0	
10517-AAA	IEEE 802.11b WiFi 2.4 GHz (DSSS, 11 Mbps, 99pc duty cycle)	X	0.96	70.11	18.69	0.00	150.0	± 9.6 %
		Y	0.85	65.61	15.70		150.0	
		Z	0.93	67.57	17.12		150.0	
10518-AAA	IEEE 802.11a/h WiFi 5 GHz (OFDM, 9 Mbps, 99pc duty cycle)	X	4.76	67.10	16.57	0.00	150.0	± 9.6 %
		Y	4.53	67.01	16.35		150.0	
		Z	4.47	67.38	16.53		150.0	
10519-AAA	IEEE 802.11a/h WiFi 5 GHz (OFDM, 12 Mbps, 99pc duty cycle)	X	5.02	67.44	16.72	0.00	150.0	± 9.6 %
		Y	4.70	67.22	16.46		150.0	
		Z	4.63	67.55	16.62		150.0	
10520-AAA	IEEE 802.11a/h WiFi 5 GHz (OFDM, 18 Mbps, 99pc duty cycle)	X	4.86	67.45	16.66	0.00	150.0	± 9.6 %
		Y	4.55	67.17	16.38		150.0	
		Z	4.48	67.50	16.54		150.0	
10521-AAA	IEEE 802.11a/h WiFi 5 GHz (OFDM, 24 Mbps, 99pc duty cycle)	X	4.79	67.47	16.66	0.00	150.0	± 9.6 %
		Y	4.48	67.16	16.36		150.0	
		Z	4.42	67.48	16.53		150.0	
10522-AAA	IEEE 802.11a/h WiFi 5 GHz (OFDM, 36 Mbps, 99pc duty cycle)	X	4.82	67.32	16.63	0.00	150.0	± 9.6 %
		Y	4.55	67.29	16.46		150.0	
		Z	4.47	67.62	16.63		150.0	

10523-AAA	IEEE 802.11a/h WiFi 5 GHz (OFDM, 48 Mbps, 99pc duty cycle)	X	4.69	67.31	16.53	0.00	150.0	± 9.6 %
		Y	4.44	67.17	16.32		150.0	
		Z	4.39	67.59	16.54		150.0	
10524-AAA	IEEE 802.11a/h WiFi 5 GHz (OFDM, 54 Mbps, 99pc duty cycle)	X	4.78	67.32	16.64	0.00	150.0	± 9.6 %
		Y	4.49	67.20	16.43		150.0	
		Z	4.42	67.57	16.62		150.0	
10525-AAA	IEEE 802.11ac WiFi (20MHz, MCS0, 99pc duty cycle)	X	4.72	66.35	16.23	0.00	150.0	± 9.6 %
		Y	4.49	66.26	16.02		150.0	
		Z	4.45	66.66	16.22		150.0	
10526-AAA	IEEE 802.11ac WiFi (20MHz, MCS1, 99pc duty cycle)	X	4.95	66.78	16.37	0.00	150.0	± 9.6 %
		Y	4.64	66.60	16.16		150.0	
		Z	4.58	66.96	16.34		150.0	
10527-AAA	IEEE 802.11ac WiFi (20MHz, MCS2, 99pc duty cycle)	X	4.86	66.80	16.35	0.00	150.0	± 9.6 %
		Y	4.57	66.56	16.10		150.0	
		Z	4.51	66.93	16.29		150.0	
10528-AAA	IEEE 802.11ac WiFi (20MHz, MCS3, 99pc duty cycle)	X	4.89	66.82	16.38	0.00	150.0	± 9.6 %
		Y	4.58	66.57	16.13		150.0	
		Z	4.52	66.94	16.32		150.0	
10529-AAA	IEEE 802.11ac WiFi (20MHz, MCS4, 99pc duty cycle)	X	4.89	66.82	16.38	0.00	150.0	± 9.6 %
		Y	4.58	66.57	16.13		150.0	
		Z	4.52	66.94	16.32		150.0	
10531-AAA	IEEE 802.11ac WiFi (20MHz, MCS6, 99pc duty cycle)	X	4.92	67.00	16.42	0.00	150.0	± 9.6 %
		Y	4.57	66.66	16.14		150.0	
		Z	4.49	66.99	16.31		150.0	
10532-AAA	IEEE 802.11ac WiFi (20MHz, MCS7, 99pc duty cycle)	X	4.76	66.93	16.40	0.00	150.0	± 9.6 %
		Y	4.43	66.51	16.07		150.0	
		Z	4.37	66.85	16.25		150.0	
10533-AAA	IEEE 802.11ac WiFi (20MHz, MCS8, 99pc duty cycle)	X	4.90	66.82	16.35	0.00	150.0	± 9.6 %
		Y	4.59	66.64	16.13		150.0	
		Z	4.53	67.03	16.33		150.0	
10534-AAA	IEEE 802.11ac WiFi (40MHz, MCS0, 99pc duty cycle)	X	5.38	66.99	16.41	0.00	150.0	± 9.6 %
		Y	5.14	66.65	16.20		150.0	
		Z	5.08	66.89	16.34		150.0	
10535-AAA	IEEE 802.11ac WiFi (40MHz, MCS1, 99pc duty cycle)	X	5.47	67.13	16.46	0.00	150.0	± 9.6 %
		Y	5.21	66.87	16.30		150.0	
		Z	5.13	67.05	16.42		150.0	
10536-AAA	IEEE 802.11ac WiFi (40MHz, MCS2, 99pc duty cycle)	X	5.32	67.12	16.45	0.00	150.0	± 9.6 %
		Y	5.08	66.81	16.25		150.0	
		Z	5.02	67.06	16.40		150.0	
10537-AAA	IEEE 802.11ac WiFi (40MHz, MCS3, 99pc duty cycle)	X	5.39	67.07	16.42	0.00	150.0	± 9.6 %
		Y	5.13	66.76	16.23		150.0	
		Z	5.08	67.03	16.39		150.0	
10538-AAA	IEEE 802.11ac WiFi (40MHz, MCS4, 99pc duty cycle)	X	5.52	67.19	16.52	0.00	150.0	± 9.6 %
		Y	5.21	66.77	16.27		150.0	
		Z	5.14	66.99	16.41		150.0	
10540-AAA	IEEE 802.11ac WiFi (40MHz, MCS6, 99pc duty cycle)	X	5.40	67.10	16.49	0.00	150.0	± 9.6 %
		Y	5.15	66.79	16.30		150.0	
		Z	5.07	66.96	16.41		150.0	

10541-AAA	IEEE 802.11ac WiFi (40MHz, MCS7, 99pc duty cycle)	X	5.41	67.10	16.49	0.00	150.0	± 9.6 %
		Y	5.12	66.64	16.21		150.0	
		Z	5.05	66.85	16.34		150.0	
10542-AAA	IEEE 802.11ac WiFi (40MHz, MCS8, 99pc duty cycle)	X	5.53	67.02	16.46	0.00	150.0	± 9.6 %
		Y	5.28	66.73	16.27		150.0	
		Z	5.21	66.95	16.40		150.0	
10543-AAA	IEEE 802.11ac WiFi (40MHz, MCS9, 99pc duty cycle)	X	5.65	67.09	16.50	0.00	150.0	± 9.6 %
		Y	5.35	66.75	16.31		150.0	
		Z	5.28	67.01	16.46		150.0	
10544-AAA	IEEE 802.11ac WiFi (80MHz, MCS0, 99pc duty cycle)	X	5.63	67.05	16.36	0.00	150.0	± 9.6 %
		Y	5.46	66.75	16.19		150.0	
		Z	5.42	66.95	16.31		150.0	
10545-AAA	IEEE 802.11ac WiFi (80MHz, MCS1, 99pc duty cycle)	X	5.85	67.43	16.48	0.00	150.0	± 9.6 %
		Y	5.67	67.24	16.39		150.0	
		Z	5.61	67.44	16.52		150.0	
10546-AAA	IEEE 802.11ac WiFi (80MHz, MCS2, 99pc duty cycle)	X	5.76	67.40	16.49	0.00	150.0	± 9.6 %
		Y	5.52	66.93	16.25		150.0	
		Z	5.45	67.09	16.35		150.0	
10547-AAA	IEEE 802.11ac WiFi (80MHz, MCS3, 99pc duty cycle)	X	5.86	67.50	16.53	0.00	150.0	± 9.6 %
		Y	5.59	67.00	16.28		150.0	
		Z	5.54	67.20	16.40		150.0	
10548-AAA	IEEE 802.11ac WiFi (80MHz, MCS4, 99pc duty cycle)	X	6.21	68.68	17.08	0.00	150.0	± 9.6 %
		Y	5.87	68.02	16.76		150.0	
		Z	5.72	67.95	16.76		150.0	
10550-AAA	IEEE 802.11ac WiFi (80MHz, MCS6, 99pc duty cycle)	X	5.77	67.31	16.45	0.00	150.0	± 9.6 %
		Y	5.57	67.05	16.32		150.0	
		Z	5.52	67.30	16.47		150.0	
10551-AAA	IEEE 802.11ac WiFi (80MHz, MCS7, 99pc duty cycle)	X	5.80	67.45	16.48	0.00	150.0	± 9.6 %
		Y	5.55	67.00	16.26		150.0	
		Z	5.45	67.07	16.32		150.0	
10552-AAA	IEEE 802.11ac WiFi (80MHz, MCS8, 99pc duty cycle)	X	5.69	67.19	16.37	0.00	150.0	± 9.6 %
		Y	5.47	66.81	16.17		150.0	
		Z	5.43	67.06	16.31		150.0	
10553-AAA	IEEE 802.11ac WiFi (80MHz, MCS9, 99pc duty cycle)	X	5.78	67.21	16.40	0.00	150.0	± 9.6 %
		Y	5.54	66.82	16.20		150.0	
		Z	5.48	67.01	16.32		150.0	
10554-AAB	IEEE 802.11ac WiFi (160MHz, MCS0, 99pc duty cycle)	X	6.03	67.43	16.45	0.00	150.0	± 9.6 %
		Y	5.89	67.12	16.28		150.0	
		Z	5.84	67.28	16.38		150.0	
10555-AAB	IEEE 802.11ac WiFi (160MHz, MCS1, 99pc duty cycle)	X	6.22	67.88	16.64	0.00	150.0	± 9.6 %
		Y	6.02	67.44	16.43		150.0	
		Z	5.95	67.54	16.50		150.0	
10556-AAB	IEEE 802.11ac WiFi (160MHz, MCS2, 99pc duty cycle)	X	6.20	67.79	16.59	0.00	150.0	± 9.6 %
		Y	6.04	67.49	16.44		150.0	
		Z	5.99	67.66	16.55		150.0	
10557-AAB	IEEE 802.11ac WiFi (160MHz, MCS3, 99pc duty cycle)	X	6.21	67.81	16.62	0.00	150.0	± 9.6 %
		Y	5.99	67.35	16.39		150.0	
		Z	5.93	67.50	16.49		150.0	

10558-AAB	IEEE 802.11ac WiFi (160MHz, MCS4, 99pc duty cycle)	X	6.28	68.03	16.75	0.00	150.0	± 9.6 %
		Y	6.04	67.52	16.49		150.0	
		Z	5.95	67.59	16.55		150.0	
10560-AAB	IEEE 802.11ac WiFi (160MHz, MCS6, 99pc duty cycle)	X	6.28	67.87	16.71	0.00	150.0	± 9.6 %
		Y	6.03	67.35	16.44		150.0	
		Z	5.96	67.49	16.53		150.0	
10561-AAB	IEEE 802.11ac WiFi (160MHz, MCS7, 99pc duty cycle)	X	6.18	67.80	16.71	0.00	150.0	± 9.6 %
		Y	5.96	67.36	16.48		150.0	
		Z	5.90	67.49	16.57		150.0	
10562-AAB	IEEE 802.11ac WiFi (160MHz, MCS8, 99pc duty cycle)	X	6.37	68.38	17.01	0.00	150.0	± 9.6 %
		Y	6.06	67.66	16.63		150.0	
		Z	5.96	67.67	16.66		150.0	
10563-AAB	IEEE 802.11ac WiFi (160MHz, MCS9, 99pc duty cycle)	X	6.58	68.54	17.02	0.00	150.0	± 9.6 %
		Y	6.18	67.65	16.59		150.0	
		Z	6.05	67.62	16.60		150.0	
10564-AAA	IEEE 802.11g WiFi 2.4 GHz (DSSS-OFDM, 9 Mbps, 99pc duty cycle)	X	5.11	67.26	16.76	0.46	150.0	± 9.6 %
		Y	4.86	67.10	16.52		150.0	
		Z	4.80	67.44	16.68		150.0	
10565-AAA	IEEE 802.11g WiFi 2.4 GHz (DSSS-OFDM, 12 Mbps, 99pc duty cycle)	X	5.41	67.77	17.08	0.46	150.0	± 9.6 %
		Y	5.08	67.53	16.83		150.0	
		Z	5.00	67.82	16.97		150.0	
10566-AAA	IEEE 802.11g WiFi 2.4 GHz (DSSS-OFDM, 18 Mbps, 99pc duty cycle)	X	5.23	67.67	16.93	0.46	150.0	± 9.6 %
		Y	4.92	67.38	16.66		150.0	
		Z	4.84	67.67	16.80		150.0	
10567-AAA	IEEE 802.11g WiFi 2.4 GHz (DSSS-OFDM, 24 Mbps, 99pc duty cycle)	X	5.26	68.03	17.24	0.46	150.0	± 9.6 %
		Y	4.95	67.77	17.01		150.0	
		Z	4.87	68.04	17.15		150.0	
10568-AAA	IEEE 802.11g WiFi 2.4 GHz (DSSS-OFDM, 36 Mbps, 99pc duty cycle)	X	5.14	67.36	16.67	0.46	150.0	± 9.6 %
		Y	4.84	67.19	16.45		150.0	
		Z	4.75	67.49	16.60		150.0	
10569-AAA	IEEE 802.11g WiFi 2.4 GHz (DSSS-OFDM, 48 Mbps, 99pc duty cycle)	X	5.19	68.02	17.24	0.46	150.0	± 9.6 %
		Y	4.92	67.92	17.11		150.0	
		Z	4.86	68.27	17.29		150.0	
10570-AAA	IEEE 802.11g WiFi 2.4 GHz (DSSS-OFDM, 54 Mbps, 99pc duty cycle)	X	5.23	67.81	17.17	0.46	150.0	± 9.6 %
		Y	4.94	67.74	17.02		150.0	
		Z	4.86	68.06	17.18		150.0	
10571-AAA	IEEE 802.11b WiFi 2.4 GHz (DSSS, 1 Mbps, 90pc duty cycle)	X	1.68	70.36	18.73	0.46	130.0	± 9.6 %
		Y	1.37	66.32	16.49		130.0	
		Z	1.41	67.39	17.29		130.0	
10572-AAA	IEEE 802.11b WiFi 2.4 GHz (DSSS, 2 Mbps, 90pc duty cycle)	X	1.75	71.47	19.28	0.46	130.0	± 9.6 %
		Y	1.40	67.01	16.89		130.0	
		Z	1.45	68.17	17.74		130.0	
10573-AAA	IEEE 802.11b WiFi 2.4 GHz (DSSS, 5.5 Mbps, 90pc duty cycle)	X	100.00	142.31	37.38	0.46	130.0	± 9.6 %
		Y	5.69	99.12	27.30		130.0	
		Z	66.26	143.73	39.41		130.0	
10574-AAA	IEEE 802.11b WiFi 2.4 GHz (DSSS, 11 Mbps, 90pc duty cycle)	X	3.57	87.71	25.60	0.46	130.0	± 9.6 %
		Y	1.70	74.22	20.29		130.0	
		Z	1.88	76.94	21.86		130.0	

10575-AAA	IEEE 802.11g WiFi 2.4 GHz (DSSS-OFDM, 6 Mbps, 90pc duty cycle)	X	4.95	67.19	16.89	0.46	130.0	± 9.6 %
		Y	4.69	67.03	16.64		130.0	
		Z	4.63	67.35	16.80		130.0	
10576-AAA	IEEE 802.11g WiFi 2.4 GHz (DSSS-OFDM, 9 Mbps, 90pc duty cycle)	X	4.98	67.35	16.96	0.46	130.0	± 9.6 %
		Y	4.72	67.20	16.72		130.0	
		Z	4.66	67.55	16.88		130.0	
10577-AAA	IEEE 802.11g WiFi 2.4 GHz (DSSS-OFDM, 12 Mbps, 90pc duty cycle)	X	5.24	67.69	17.13	0.46	130.0	± 9.6 %
		Y	4.90	67.46	16.87		130.0	
		Z	4.82	67.76	17.01		130.0	
10578-AAA	IEEE 802.11g WiFi 2.4 GHz (DSSS-OFDM, 18 Mbps, 90pc duty cycle)	X	5.14	67.89	17.23	0.46	130.0	± 9.6 %
		Y	4.81	67.63	16.98		130.0	
		Z	4.73	67.92	17.12		130.0	
10579-AAA	IEEE 802.11g WiFi 2.4 GHz (DSSS-OFDM, 24 Mbps, 90pc duty cycle)	X	4.94	67.39	16.68	0.46	130.0	± 9.6 %
		Y	4.58	66.91	16.29		130.0	
		Z	4.50	67.21	16.45		130.0	
10580-AAA	IEEE 802.11g WiFi 2.4 GHz (DSSS-OFDM, 36 Mbps, 90pc duty cycle)	X	4.98	67.29	16.65	0.46	130.0	± 9.6 %
		Y	4.62	66.97	16.32		130.0	
		Z	4.54	67.27	16.48		130.0	
10581-AAA	IEEE 802.11g WiFi 2.4 GHz (DSSS-OFDM, 48 Mbps, 90pc duty cycle)	X	5.07	68.07	17.23	0.46	130.0	± 9.6 %
		Y	4.72	67.70	16.95		130.0	
		Z	4.65	68.04	17.12		130.0	
10582-AAA	IEEE 802.11g WiFi 2.4 GHz (DSSS-OFDM, 54 Mbps, 90pc duty cycle)	X	4.90	67.13	16.49	0.46	130.0	± 9.6 %
		Y	4.51	66.68	16.07		130.0	
		Z	4.43	67.00	16.24		130.0	
10583-AAA	IEEE 802.11a/h WiFi 5 GHz (OFDM, 6 Mbps, 90pc duty cycle)	X	4.95	67.19	16.89	0.46	130.0	± 9.6 %
		Y	4.69	67.03	16.64		130.0	
		Z	4.63	67.35	16.80		130.0	
10584-AAA	IEEE 802.11a/h WiFi 5 GHz (OFDM, 9 Mbps, 90pc duty cycle)	X	4.98	67.35	16.96	0.46	130.0	± 9.6 %
		Y	4.72	67.20	16.72		130.0	
		Z	4.66	67.55	16.88		130.0	
10585-AAA	IEEE 802.11a/h WiFi 5 GHz (OFDM, 12 Mbps, 90pc duty cycle)	X	5.24	67.69	17.13	0.46	130.0	± 9.6 %
		Y	4.90	67.46	16.87		130.0	
		Z	4.82	67.76	17.01		130.0	
10586-AAA	IEEE 802.11a/h WiFi 5 GHz (OFDM, 18 Mbps, 90pc duty cycle)	X	5.14	67.89	17.23	0.46	130.0	± 9.6 %
		Y	4.81	67.63	16.98		130.0	
		Z	4.73	67.92	17.12		130.0	
10587-AAA	IEEE 802.11a/h WiFi 5 GHz (OFDM, 24 Mbps, 90pc duty cycle)	X	4.94	67.39	16.68	0.46	130.0	± 9.6 %
		Y	4.58	66.91	16.29		130.0	
		Z	4.50	67.21	16.45		130.0	
10588-AAA	IEEE 802.11a/h WiFi 5 GHz (OFDM, 36 Mbps, 90pc duty cycle)	X	4.98	67.29	16.65	0.46	130.0	± 9.6 %
		Y	4.62	66.97	16.32		130.0	
		Z	4.54	67.27	16.48		130.0	
10589-AAA	IEEE 802.11a/h WiFi 5 GHz (OFDM, 48 Mbps, 90pc duty cycle)	X	5.07	68.07	17.23	0.46	130.0	± 9.6 %
		Y	4.72	67.70	16.95		130.0	
		Z	4.65	68.04	17.12		130.0	
10590-AAA	IEEE 802.11a/h WiFi 5 GHz (OFDM, 54 Mbps, 90pc duty cycle)	X	4.90	67.13	16.49	0.46	130.0	± 9.6 %
		Y	4.51	66.68	16.07		130.0	
		Z	4.43	67.00	16.24		130.0	

10591-AAA	IEEE 802.11n (HT Mixed, 20MHz, MCS0, 90pc duty cycle)	X	5.10	67.21	16.96	0.46	130.0	± 9.6 %
		Y	4.84	67.07	16.74		130.0	
		Z	4.77	67.39	16.89		130.0	
10592-AAA	IEEE 802.11n (HT Mixed, 20MHz, MCS1, 90pc duty cycle)	X	5.29	67.56	17.07	0.46	130.0	± 9.6 %
		Y	4.98	67.40	16.87		130.0	
		Z	4.90	67.69	17.01		130.0	
10593-AAA	IEEE 802.11n (HT Mixed, 20MHz, MCS2, 90pc duty cycle)	X	5.23	67.57	17.01	0.46	130.0	± 9.6 %
		Y	4.90	67.30	16.75		130.0	
		Z	4.82	67.59	16.88		130.0	
10594-AAA	IEEE 802.11n (HT Mixed, 20MHz, MCS3, 90pc duty cycle)	X	5.28	67.68	17.13	0.46	130.0	± 9.6 %
		Y	4.96	67.47	16.91		130.0	
		Z	4.88	67.75	17.04		130.0	
10595-AAA	IEEE 802.11n (HT Mixed, 20MHz, MCS4, 90pc duty cycle)	X	5.27	67.71	17.06	0.46	130.0	± 9.6 %
		Y	4.93	67.44	16.81		130.0	
		Z	4.85	67.75	16.96		130.0	
10596-AAA	IEEE 802.11n (HT Mixed, 20MHz, MCS5, 90pc duty cycle)	X	5.21	67.70	17.06	0.46	130.0	± 9.6 %
		Y	4.86	67.44	16.81		130.0	
		Z	4.78	67.74	16.97		130.0	
10597-AAA	IEEE 802.11n (HT Mixed, 20MHz, MCS6, 90pc duty cycle)	X	5.16	67.68	17.00	0.46	130.0	± 9.6 %
		Y	4.81	67.32	16.68		130.0	
		Z	4.73	67.61	16.83		130.0	
10598-AAA	IEEE 802.11n (HT Mixed, 20MHz, MCS7, 90pc duty cycle)	X	5.15	67.96	17.27	0.46	130.0	± 9.6 %
		Y	4.80	67.55	16.95		130.0	
		Z	4.72	67.82	17.08		130.0	
10599-AAA	IEEE 802.11n (HT Mixed, 40MHz, MCS0, 90pc duty cycle)	X	5.77	67.84	17.13	0.46	130.0	± 9.6 %
		Y	5.52	67.58	16.96		130.0	
		Z	5.45	67.81	17.10		130.0	
10600-AAA	IEEE 802.11n (HT Mixed, 40MHz, MCS1, 90pc duty cycle)	X	6.05	68.67	17.52	0.46	130.0	± 9.6 %
		Y	5.68	68.13	17.21		130.0	
		Z	5.58	68.26	17.30		130.0	
10601-AAA	IEEE 802.11n (HT Mixed, 40MHz, MCS2, 90pc duty cycle)	X	5.85	68.16	17.28	0.46	130.0	± 9.6 %
		Y	5.55	67.80	17.06		130.0	
		Z	5.46	67.98	17.17		130.0	
10602-AAA	IEEE 802.11n (HT Mixed, 40MHz, MCS3, 90pc duty cycle)	X	5.99	68.30	17.27	0.46	130.0	± 9.6 %
		Y	5.68	67.95	17.06		130.0	
		Z	5.60	68.17	17.19		130.0	
10603-AAA	IEEE 802.11n (HT Mixed, 40MHz, MCS4, 90pc duty cycle)	X	6.09	68.64	17.55	0.46	130.0	± 9.6 %
		Y	5.74	68.19	17.31		130.0	
		Z	5.66	68.42	17.44		130.0	
10604-AAA	IEEE 802.11n (HT Mixed, 40MHz, MCS5, 90pc duty cycle)	X	5.79	67.86	17.16	0.46	130.0	± 9.6 %
		Y	5.59	67.76	17.08		130.0	
		Z	5.54	68.06	17.25		130.0	
10605-AAA	IEEE 802.11n (HT Mixed, 40MHz, MCS6, 90pc duty cycle)	X	5.90	68.15	17.31	0.46	130.0	± 9.6 %
		Y	5.67	68.01	17.21		130.0	
		Z	5.56	68.12	17.28		130.0	
10606-AAA	IEEE 802.11n (HT Mixed, 40MHz, MCS7, 90pc duty cycle)	X	5.65	67.59	16.91	0.46	130.0	± 9.6 %
		Y	5.37	67.19	16.65		130.0	
		Z	5.33	67.51	16.83		130.0	

10607-AAA	IEEE 802.11ac WiFi (20MHz, MCS0, 90pc duty cycle)	X	4.92	66.49	16.57	0.46	130.0	± 9.6 %
		Y	4.68	66.39	16.37		130.0	
		Z	4.62	66.76	16.54		130.0	
10608-AAA	IEEE 802.11ac WiFi (20MHz, MCS1, 90pc duty cycle)	X	5.16	66.93	16.72	0.46	130.0	± 9.6 %
		Y	4.85	66.77	16.53		130.0	
		Z	4.77	67.10	16.69		130.0	
10609-AAA	IEEE 802.11ac WiFi (20MHz, MCS2, 90pc duty cycle)	X	5.06	66.87	16.62	0.46	130.0	± 9.6 %
		Y	4.74	66.62	16.36		130.0	
		Z	4.67	66.96	16.53		130.0	
10610-AAA	IEEE 802.11ac WiFi (20MHz, MCS3, 90pc duty cycle)	X	5.11	67.01	16.76	0.46	130.0	± 9.6 %
		Y	4.79	66.78	16.53		130.0	
		Z	4.72	67.11	16.69		130.0	
10611-AAA	IEEE 802.11ac WiFi (20MHz, MCS4, 90pc duty cycle)	X	5.05	66.92	16.66	0.46	130.0	± 9.6 %
		Y	4.71	66.59	16.38		130.0	
		Z	4.64	66.93	16.55		130.0	
10612-AAA	IEEE 802.11ac WiFi (20MHz, MCS5, 90pc duty cycle)	X	5.07	67.04	16.68	0.46	130.0	± 9.6 %
		Y	4.72	66.76	16.43		130.0	
		Z	4.64	67.09	16.61		130.0	
10613-AAA	IEEE 802.11ac WiFi (20MHz, MCS6, 90pc duty cycle)	X	5.09	66.98	16.60	0.46	130.0	± 9.6 %
		Y	4.71	66.61	16.29		130.0	
		Z	4.63	66.91	16.45		130.0	
10614-AAA	IEEE 802.11ac WiFi (20MHz, MCS7, 90pc duty cycle)	X	5.02	67.21	16.84	0.46	130.0	± 9.6 %
		Y	4.67	66.81	16.53		130.0	
		Z	4.59	67.11	16.69		130.0	
10615-AAA	IEEE 802.11ac WiFi (20MHz, MCS8, 90pc duty cycle)	X	5.05	66.70	16.43	0.46	130.0	± 9.6 %
		Y	4.71	66.43	16.16		130.0	
		Z	4.64	66.79	16.34		130.0	
10616-AAA	IEEE 802.11ac WiFi (40MHz, MCS0, 90pc duty cycle)	X	5.58	67.10	16.74	0.46	130.0	± 9.6 %
		Y	5.33	66.79	16.55		130.0	
		Z	5.25	67.00	16.67		130.0	
10617-AAA	IEEE 802.11ac WiFi (40MHz, MCS1, 90pc duty cycle)	X	5.66	67.25	16.77	0.46	130.0	± 9.6 %
		Y	5.41	67.04	16.65		130.0	
		Z	5.31	67.19	16.74		130.0	
10618-AAA	IEEE 802.11ac WiFi (40MHz, MCS2, 90pc duty cycle)	X	5.54	67.29	16.82	0.46	130.0	± 9.6 %
		Y	5.29	67.03	16.66		130.0	
		Z	5.22	67.24	16.78		130.0	
10619-AAA	IEEE 802.11ac WiFi (40MHz, MCS3, 90pc duty cycle)	X	5.56	67.09	16.66	0.46	130.0	± 9.6 %
		Y	5.30	66.81	16.48		130.0	
		Z	5.23	67.05	16.63		130.0	
10620-AAA	IEEE 802.11ac WiFi (40MHz, MCS4, 90pc duty cycle)	X	5.71	67.30	16.81	0.46	130.0	± 9.6 %
		Y	5.38	66.84	16.54		130.0	
		Z	5.30	67.04	16.67		130.0	
10621-AAA	IEEE 802.11ac WiFi (40MHz, MCS5, 90pc duty cycle)	X	5.66	67.28	16.90	0.46	130.0	± 9.6 %
		Y	5.39	66.98	16.73		130.0	
		Z	5.30	67.12	16.82		130.0	
10622-AAA	IEEE 802.11ac WiFi (40MHz, MCS6, 90pc duty cycle)	X	5.65	67.37	16.94	0.46	130.0	± 9.6 %
		Y	5.40	67.13	16.80		130.0	
		Z	5.30	67.22	16.87		130.0	

10623-AAA	IEEE 802.11ac WiFi (40MHz, MCS7, 90pc duty cycle)	X	5.58	67.14	16.73	0.46	130.0	± 9.6 %
		Y	5.28	66.65	16.43		130.0	
		Z	5.18	66.78	16.52		130.0	
10624-AAA	IEEE 802.11ac WiFi (40MHz, MCS8, 90pc duty cycle)	X	5.72	67.10	16.77	0.46	130.0	± 9.6 %
		Y	5.47	66.85	16.60		130.0	
		Z	5.38	67.03	16.70		130.0	
10625-AAA	IEEE 802.11ac WiFi (40MHz, MCS9, 90pc duty cycle)	X	6.05	67.87	17.19	0.46	130.0	± 9.6 %
		Y	5.77	67.66	17.06		130.0	
		Z	5.49	67.24	16.87		130.0	
10626-AAA	IEEE 802.11ac WiFi (80MHz, MCS0, 90pc duty cycle)	X	5.80	67.08	16.64	0.46	130.0	± 9.6 %
		Y	5.63	66.82	16.50		130.0	
		Z	5.57	66.99	16.60		130.0	
10627-AAA	IEEE 802.11ac WiFi (80MHz, MCS1, 90pc duty cycle)	X	6.05	67.56	16.82	0.46	130.0	± 9.6 %
		Y	5.90	67.51	16.81		130.0	
		Z	5.83	67.67	16.91		130.0	
10628-AAA	IEEE 802.11ac WiFi (80MHz, MCS2, 90pc duty cycle)	X	5.89	67.33	16.66	0.46	130.0	± 9.6 %
		Y	5.66	66.90	16.43		130.0	
		Z	5.58	67.01	16.51		130.0	
10629-AAA	IEEE 802.11ac WiFi (80MHz, MCS3, 90pc duty cycle)	X	6.01	67.46	16.71	0.46	130.0	± 9.6 %
		Y	5.74	67.00	16.48		130.0	
		Z	5.68	67.19	16.60		130.0	
10630-AAA	IEEE 802.11ac WiFi (80MHz, MCS4, 90pc duty cycle)	X	6.66	69.52	17.74	0.46	130.0	± 9.6 %
		Y	6.23	68.64	17.29		130.0	
		Z	5.99	68.32	17.17		130.0	
10631-AAA	IEEE 802.11ac WiFi (80MHz, MCS5, 90pc duty cycle)	X	6.51	69.16	17.72	0.46	130.0	± 9.6 %
		Y	6.05	68.21	17.27		130.0	
		Z	5.91	68.16	17.27		130.0	
10632-AAA	IEEE 802.11ac WiFi (80MHz, MCS6, 90pc duty cycle)	X	6.07	67.76	17.04	0.46	130.0	± 9.6 %
		Y	5.87	67.57	16.97		130.0	
		Z	5.81	67.79	17.10		130.0	
10633-AAA	IEEE 802.11ac WiFi (80MHz, MCS7, 90pc duty cycle)	X	6.04	67.71	16.86	0.46	130.0	± 9.6 %
		Y	5.71	67.04	16.54		130.0	
		Z	5.62	67.14	16.61		130.0	
10634-AAA	IEEE 802.11ac WiFi (80MHz, MCS8, 90pc duty cycle)	X	6.01	67.64	16.89	0.46	130.0	± 9.6 %
		Y	5.69	67.06	16.60		130.0	
		Z	5.63	67.23	16.71		130.0	
10635-AAA	IEEE 802.11ac WiFi (80MHz, MCS9, 90pc duty cycle)	X	5.88	66.99	16.33	0.46	130.0	± 9.6 %
		Y	5.57	66.39	16.00		130.0	
		Z	5.49	66.55	16.11		130.0	
10636-AAB	IEEE 802.11ac WiFi (160MHz, MCS0, 90pc duty cycle)	X	6.20	67.47	16.73	0.46	130.0	± 9.6 %
		Y	6.06	67.19	16.58		130.0	
		Z	6.01	67.33	16.67		130.0	
10637-AAB	IEEE 802.11ac WiFi (160MHz, MCS1, 90pc duty cycle)	X	6.43	68.00	16.96	0.46	130.0	± 9.6 %
		Y	6.23	67.63	16.79		130.0	
		Z	6.14	67.69	16.84		130.0	
10638-AAB	IEEE 802.11ac WiFi (160MHz, MCS2, 90pc duty cycle)	X	6.38	67.82	16.85	0.46	130.0	± 9.6 %
		Y	6.23	67.59	16.75		130.0	
		Z	6.16	67.71	16.83		130.0	

10639-AAB	IEEE 802.11ac WiFi (160MHz, MCS3, 90pc duty cycle)	X	6.40	67.91	16.95	0.46	130.0	± 9.6 %
		Y	6.18	67.47	16.73		130.0	
		Z	6.11	67.58	16.80		130.0	
10640-AAB	IEEE 802.11ac WiFi (160MHz, MCS4, 90pc duty cycle)	X	6.45	68.06	16.97	0.46	130.0	± 9.6 %
		Y	6.19	67.49	16.68		130.0	
		Z	6.09	67.54	16.73		130.0	
10641-AAB	IEEE 802.11ac WiFi (160MHz, MCS5, 90pc duty cycle)	X	6.42	67.72	16.82	0.46	130.0	± 9.6 %
		Y	6.26	67.48	16.70		130.0	
		Z	6.18	67.60	16.78		130.0	
10642-AAB	IEEE 802.11ac WiFi (160MHz, MCS6, 90pc duty cycle)	X	6.51	68.09	17.16	0.46	130.0	± 9.6 %
		Y	6.27	67.64	16.94		130.0	
		Z	6.19	67.74	17.01		130.0	
10643-AAB	IEEE 802.11ac WiFi (160MHz, MCS7, 90pc duty cycle)	X	6.33	67.78	16.92	0.46	130.0	± 9.6 %
		Y	6.13	67.39	16.71		130.0	
		Z	6.05	67.49	16.79		130.0	
10644-AAB	IEEE 802.11ac WiFi (160MHz, MCS8, 90pc duty cycle)	X	6.62	68.66	17.38	0.46	130.0	± 9.6 %
		Y	6.24	67.74	16.91		130.0	
		Z	6.11	67.69	16.91		130.0	
10645-AAB	IEEE 802.11ac WiFi (160MHz, MCS9, 90pc duty cycle)	X	6.82	68.76	17.37	0.46	130.0	± 9.6 %
		Y	6.42	67.94	16.97		130.0	
		Z	6.29	67.89	16.97		130.0	
10646-AAD	LTE-TDD (SC-FDMA, 1 RB, 5 MHz, QPSK, UL Subframe=2,7)	X	22.37	99.45	32.18	9.30	60.0	± 9.6 %
		Y	34.93	118.52	39.50		60.0	
		Z	65.31	137.01	45.15		60.0	
10647-AAC	LTE-TDD (SC-FDMA, 1 RB, 20 MHz, QPSK, UL Subframe=2,7)	X	23.87	101.54	32.95	9.30	60.0	± 9.6 %
		Y	35.03	119.53	39.96		60.0	
		Z	61.92	136.93	45.35		60.0	
10648-AAA	CDMA2000 (1x Advanced)	X	1.11	70.04	15.37	0.00	150.0	± 9.6 %
		Y	0.68	63.85	10.64		150.0	
		Z	0.72	65.39	11.21		150.0	
10652-AAB	LTE-TDD (OFDMA, 5 MHz, E-TM 3.1, Clipping 44%)	X	5.43	70.91	18.53	2.23	80.0	± 9.6 %
		Y	4.44	69.41	17.59		80.0	
		Z	4.46	70.35	17.94		80.0	
10653-AAB	LTE-TDD (OFDMA, 10 MHz, E-TM 3.1, Clipping 44%)	X	5.75	69.79	18.37	2.23	80.0	± 9.6 %
		Y	4.85	68.29	17.59		80.0	
		Z	4.80	68.81	17.83		80.0	
10654-AAB	LTE-TDD (OFDMA, 15 MHz, E-TM 3.1, Clipping 44%)	X	5.63	69.47	18.36	2.23	80.0	± 9.6 %
		Y	4.81	67.88	17.59		80.0	
		Z	4.76	68.31	17.81		80.0	
10655-AAB	LTE-TDD (OFDMA, 20 MHz, E-TM 3.1, Clipping 44%)	X	5.69	69.55	18.41	2.23	80.0	± 9.6 %
		Y	4.87	67.81	17.62		80.0	
		Z	4.82	68.18	17.82		80.0	

^F Uncertainty is determined using the max. deviation from linear response applying rectangular distribution and is expressed for the square of the field value.



Accredited by the Swiss Accreditation Service (SAS)
The Swiss Accreditation Service is one of the signatories to the EA
Multilateral Agreement for the recognition of calibration certificates

Accreditation No.: **SCS 0108**

Client **PC Test**

Certificate No: **ES3-3209_Mar17**

CALIBRATION CERTIFICATE

Object **ES3DV3 - SN:3209**

Calibration procedure(s) **QA CAL-01.v9, QA CAL-23.v5, QA CAL-25.v6
Calibration procedure for dosimetric E-field probes**

*BNW
03-27-2017*

Calibration date: **March 14, 2017**

This calibration certificate documents the traceability to national standards, which realize the physical units of measurements (SI).
The measurements and the uncertainties with confidence probability are given on the following pages and are part of the certificate.

All calibrations have been conducted in the closed laboratory facility: environment temperature (22 ± 3)°C and humidity < 70%.

Calibration Equipment used (M&TE critical for calibration)

Primary Standards	ID	Cal Date (Certificate No.)	Scheduled Calibration
Power meter NRP	SN: 104778	06-Apr-16 (No. 217-02288/02289)	Apr-17
Power sensor NRP-Z91	SN: 103244	06-Apr-16 (No. 217-02288)	Apr-17
Power sensor NRP-Z91	SN: 103245	06-Apr-16 (No. 217-02289)	Apr-17
Reference 20 dB Attenuator	SN: S5277 (20x)	05-Apr-16 (No. 217-02293)	Apr-17
Reference Probe ES3DV2	SN: 3013	31-Dec-16 (No. ES3-3013_Dec16)	Dec-17
DAE4	SN: 660	7-Dec-16 (No. DAE4-660_Dec16)	Dec-17
Secondary Standards	ID	Check Date (in house)	Scheduled Check
Power meter E4419B	SN: GB41293874	06-Apr-16 (in house check Jun-16)	In house check: Jun-18
Power sensor E4412A	SN: MY41498087	06-Apr-16 (in house check Jun-16)	In house check: Jun-18
Power sensor E4412A	SN: 000110210	06-Apr-16 (in house check Jun-16)	In house check: Jun-18
RF generator HP 8648C	SN: US3642U01700	04-Aug-99 (in house check Jun-16)	In house check: Jun-18
Network Analyzer HP 8753E	SN: US37390585	18-Oct-01 (in house check Oct-16)	In house check: Oct-17

	Name	Function	Signature
Calibrated by:	Jeton Kastrati	Laboratory Technician	
Approved by:	Katja Pokovic	Technical Manager	
			Issued: March 16, 2017
This calibration certificate shall not be reproduced except in full without written approval of the laboratory.			



Accredited by the Swiss Accreditation Service (SAS)

Accreditation No.: **SCS 0108**

The Swiss Accreditation Service is one of the signatories to the EA Multilateral Agreement for the recognition of calibration certificates

Glossary:

TSL	tissue simulating liquid
NORM _{x,y,z}	sensitivity in free space
ConvF	sensitivity in TSL / NORM _{x,y,z}
DCP	diode compression point
CF	crest factor (1/duty_cycle) of the RF signal
A, B, C, D	modulation dependent linearization parameters
Polarization ϕ	ϕ rotation around probe axis
Polarization ϑ	ϑ rotation around an axis that is in the plane normal to probe axis (at measurement center), i.e., $\vartheta = 0$ is normal to probe axis
Connector Angle	information used in DASY system to align probe sensor X to the robot coordinate system

Calibration is Performed According to the Following Standards:

- a) IEEE Std 1528-2013, "IEEE Recommended Practice for Determining the Peak Spatial-Averaged Specific Absorption Rate (SAR) in the Human Head from Wireless Communications Devices: Measurement Techniques", June 2013
- b) IEC 62209-1, "Procedure to measure the Specific Absorption Rate (SAR) for hand-held devices used in close proximity to the ear (frequency range of 300 MHz to 3 GHz)", February 2005
- c) IEC 62209-2, "Procedure to determine the Specific Absorption Rate (SAR) for wireless communication devices used in close proximity to the human body (frequency range of 30 MHz to 6 GHz)", March 2010
- d) KDB 865664, "SAR Measurement Requirements for 100 MHz to 6 GHz"

Methods Applied and Interpretation of Parameters:

- *NORM_{x,y,z}*: Assessed for E-field polarization $\vartheta = 0$ ($f \leq 900$ MHz in TEM-cell; $f > 1800$ MHz: R22 waveguide). *NORM_{x,y,z}* are only intermediate values, i.e., the uncertainties of *NORM_{x,y,z}* does not affect the E^2 -field uncertainty inside TSL (see below *ConvF*).
- *NORM(f)_{x,y,z}* = *NORM_{x,y,z}* * *frequency_response* (see Frequency Response Chart). This linearization is implemented in DASY4 software versions later than 4.2. The uncertainty of the frequency response is included in the stated uncertainty of *ConvF*.
- *DCP_{x,y,z}*: DCP are numerical linearization parameters assessed based on the data of power sweep with CW signal (no uncertainty required). DCP does not depend on frequency nor media.
- *PAR*: PAR is the Peak to Average Ratio that is not calibrated but determined based on the signal characteristics
- *A_{x,y,z}*; *B_{x,y,z}*; *C_{x,y,z}*; *D_{x,y,z}*; *VR_{x,y,z}*; *A, B, C, D* are numerical linearization parameters assessed based on the data of power sweep for specific modulation signal. The parameters do not depend on frequency nor media. *VR* is the maximum calibration range expressed in RMS voltage across the diode.
- *ConvF* and *Boundary Effect Parameters*: Assessed in flat phantom using E-field (or Temperature Transfer Standard for $f \leq 800$ MHz) and inside waveguide using analytical field distributions based on power measurements for $f > 800$ MHz. The same setups are used for assessment of the parameters applied for boundary compensation (alpha, depth) of which typical uncertainty values are given. These parameters are used in DASY4 software to improve probe accuracy close to the boundary. The sensitivity in TSL corresponds to *NORM_{x,y,z}* * *ConvF* whereby the uncertainty corresponds to that given for *ConvF*. A frequency dependent *ConvF* is used in DASY version 4.4 and higher which allows extending the validity from ± 50 MHz to ± 100 MHz.
- *Spherical isotropy (3D deviation from isotropy)*: in a field of low gradients realized using a flat phantom exposed by a patch antenna.
- *Sensor Offset*: The sensor offset corresponds to the offset of virtual measurement center from the probe tip (on probe axis). No tolerance required.
- *Connector Angle*: The angle is assessed using the information gained by determining the *NORM_x* (no uncertainty required).

Probe ES3DV3

SN:3209

Manufactured: October 14, 2008
Calibrated: March 14, 2017

Calibrated for DASY/EASY Systems
(Note: non-compatible with DASY2 system!)

DASY/EASY - Parameters of Probe: ES3DV3 - SN:3209

Basic Calibration Parameters

	Sensor X	Sensor Y	Sensor Z	Unc (k=2)
Norm ($\mu\text{V}/(\text{V}/\text{m})^2$) ^A	1.31	1.28	1.10	$\pm 10.1 \%$
DCP (mV) ^B	98.7	100.9	101.0	

Modulation Calibration Parameters

UID	Communication System Name		A dB	B dB $\sqrt{\mu\text{V}}$	C	D dB	VR mV	Unc ^E (k=2)
0	CW	X	0.0	0.0	1.0	0.00	185.7	$\pm 3.5 \%$
		Y	0.0	0.0	1.0		188.4	
		Z	0.0	0.0	1.0		174.0	

Note: For details on UID parameters see Appendix.

Sensor Model Parameters

	C1 fF	C2 fF	α V^{-1}	T1 $\text{ms}\cdot\text{V}^{-2}$	T2 $\text{ms}\cdot\text{V}^{-1}$	T3 ms	T4 V^{-2}	T5 V^{-1}	T6
X	55.02	400.2	36.4	24.81	1.139	5.1	1.332	0.294	1.012
Y	53.76	389.5	36.01	25.47	1.401	5.1	1.486	0.333	1.011
Z	54.22	392	35.92	24.25	1.184	5.1	1.305	0.356	1.012

The reported uncertainty of measurement is stated as the standard uncertainty of measurement multiplied by the coverage factor $k=2$, which for a normal distribution corresponds to a coverage probability of approximately 95%.

^A The uncertainties of Norm X,Y,Z do not affect the E^2 -field uncertainty inside TSL (see Pages 5 and 6).

^B Numerical linearization parameter: uncertainty not required.

^E Uncertainty is determined using the max. deviation from linear response applying rectangular distribution and is expressed for the square of the field value.

DASY/EASY - Parameters of Probe: ES3DV3 - SN:3209

Calibration Parameter Determined in Head Tissue Simulating Media

f (MHz) ^C	Relative Permittivity ^F	Conductivity (S/m) ^F	ConvF X	ConvF Y	ConvF Z	Alpha ^G	Depth ^G (mm)	Unc (k=2)
750	41.9	0.89	6.76	6.76	6.76	0.80	1.17	± 12.0 %
835	41.5	0.90	6.36	6.36	6.36	0.63	1.31	± 12.0 %
1750	40.1	1.37	5.50	5.50	5.50	0.74	1.16	± 12.0 %
1900	40.0	1.40	5.31	5.31	5.31	0.63	1.30	± 12.0 %
2300	39.5	1.67	4.92	4.92	4.92	0.80	1.20	± 12.0 %
2450	39.2	1.80	4.72	4.72	4.72	0.71	1.33	± 12.0 %
2600	39.0	1.96	4.53	4.53	4.53	0.69	1.37	± 12.0 %

^C Frequency validity above 300 MHz of ± 100 MHz only applies for DASY v4.4 and higher (see Page 2), else it is restricted to ± 50 MHz. The uncertainty is the RSS of the ConvF uncertainty at calibration frequency and the uncertainty for the indicated frequency band. Frequency validity below 300 MHz is ± 10, 25, 40, 50 and 70 MHz for ConvF assessments at 30, 64, 128, 150 and 220 MHz respectively. Above 5 GHz frequency validity can be extended to ± 110 MHz.

^F At frequencies below 3 GHz, the validity of tissue parameters (ϵ and σ) can be relaxed to ± 10% if liquid compensation formula is applied to measured SAR values. At frequencies above 3 GHz, the validity of tissue parameters (ϵ and σ) is restricted to ± 5%. The uncertainty is the RSS of the ConvF uncertainty for indicated target tissue parameters.

^G Alpha/Depth are determined during calibration. SPEAG warrants that the remaining deviation due to the boundary effect after compensation is always less than ± 1% for frequencies below 3 GHz and below ± 2% for frequencies between 3-6 GHz at any distance larger than half the probe tip diameter from the boundary.

DASY/EASY - Parameters of Probe: ES3DV3 - SN:3209

Calibration Parameter Determined in Body Tissue Simulating Media

f (MHz) ^C	Relative Permittivity ^F	Conductivity (S/m) ^F	ConvF X	ConvF Y	ConvF Z	Alpha ^G	Depth ^G (mm)	Unc (k=2)
750	55.5	0.96	6.44	6.44	6.44	0.80	1.17	± 12.0 %
835	55.2	0.97	6.36	6.36	6.36	0.80	1.20	± 12.0 %
1750	53.4	1.49	5.13	5.13	5.13	0.51	1.53	± 12.0 %
1900	53.3	1.52	4.93	4.93	4.93	0.50	1.59	± 12.0 %
2300	52.9	1.81	4.62	4.62	4.62	0.80	1.24	± 12.0 %
2450	52.7	1.95	4.48	4.48	4.48	0.80	1.24	± 12.0 %
2600	52.5	2.16	4.26	4.26	4.26	0.80	1.20	± 12.0 %

^C Frequency validity above 300 MHz of ± 100 MHz only applies for DASY v4.4 and higher (see Page 2), else it is restricted to ± 50 MHz. The uncertainty is the RSS of the ConvF uncertainty at calibration frequency and the uncertainty for the indicated frequency band. Frequency validity below 300 MHz is ± 10, 25, 40, 50 and 70 MHz for ConvF assessments at 30, 64, 128, 150 and 220 MHz respectively. Above 5 GHz frequency validity can be extended to ± 110 MHz.

^F At frequencies below 3 GHz, the validity of tissue parameters (ϵ and σ) can be relaxed to ± 10% if liquid compensation formula is applied to measured SAR values. At frequencies above 3 GHz, the validity of tissue parameters (ϵ and σ) is restricted to ± 5%. The uncertainty is the RSS of the ConvF uncertainty for indicated target tissue parameters.

^G Alpha/Depth are determined during calibration. SPEAG warrants that the remaining deviation due to the boundary effect after compensation is always less than ± 1% for frequencies below 3 GHz and below ± 2% for frequencies between 3-6 GHz at any distance larger than half the probe tip diameter from the boundary.

Frequency Response of E-Field

(TEM-Cell:ifi110 EXX, Waveguide: R22)

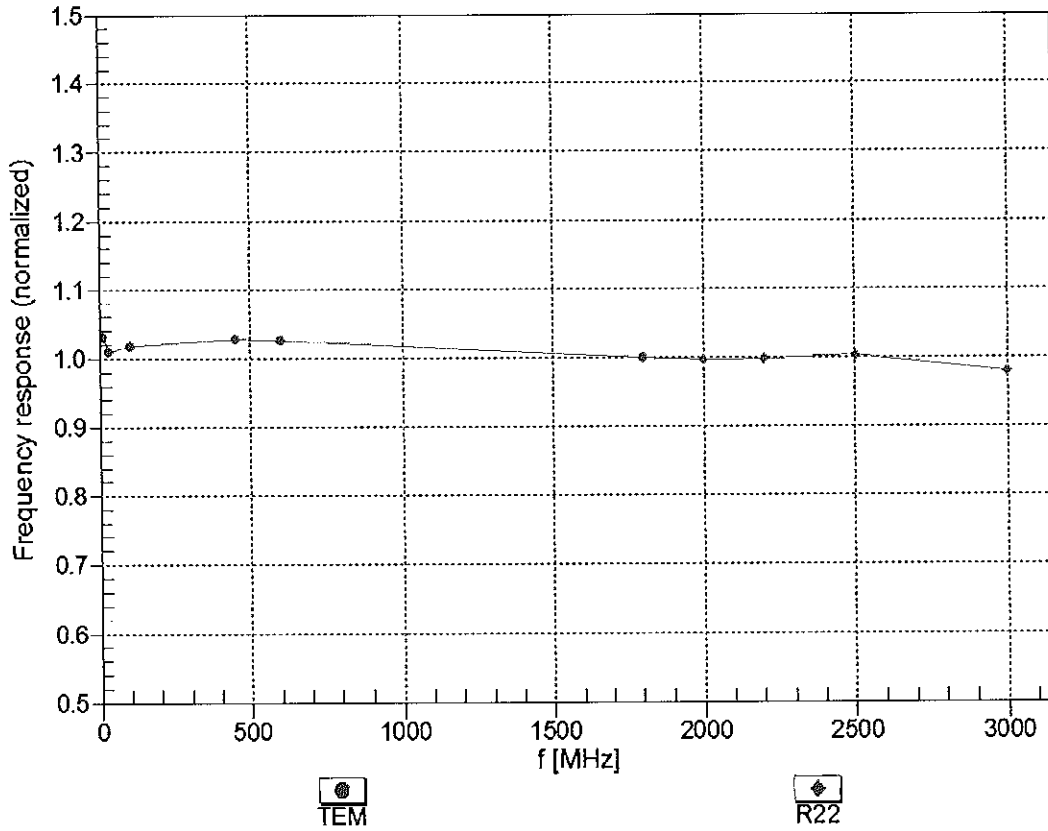

Uncertainty of Frequency Response of E-field: $\pm 6.3\%$ (k=2)

Receiving Pattern (ϕ), $\vartheta = 0^\circ$

f=600 MHz, TEM

f=1800 MHz, R22

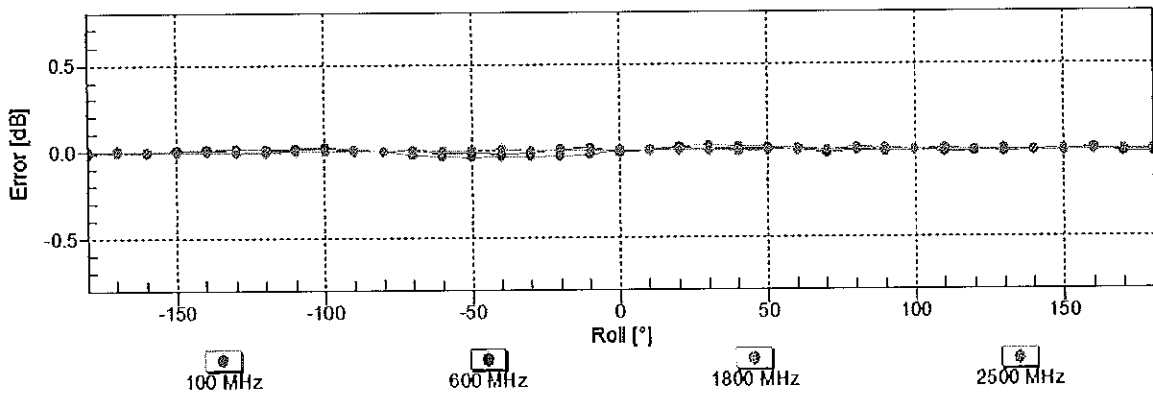
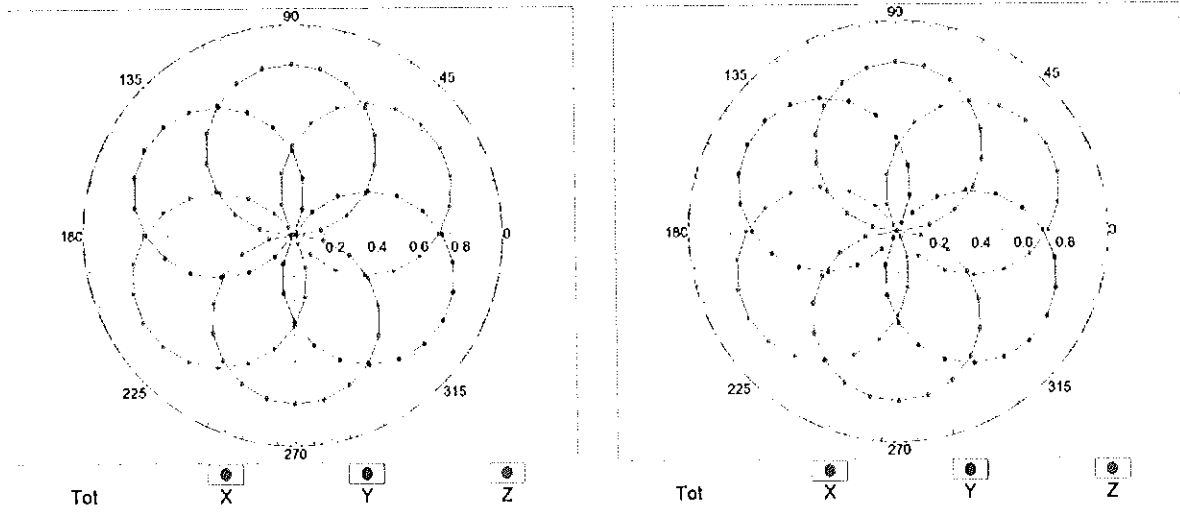

Uncertainty of Axial Isotropy Assessment: $\pm 0.5\%$ (k=2)

Dynamic Range f(SAR_{head}) (TEM cell , f_{eval}= 1900 MHz)

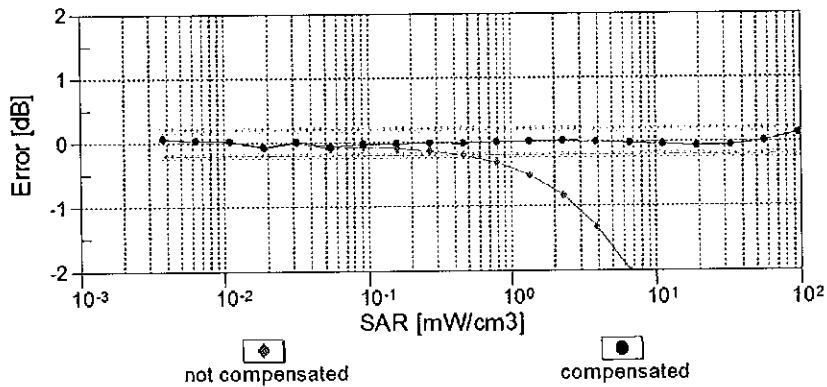
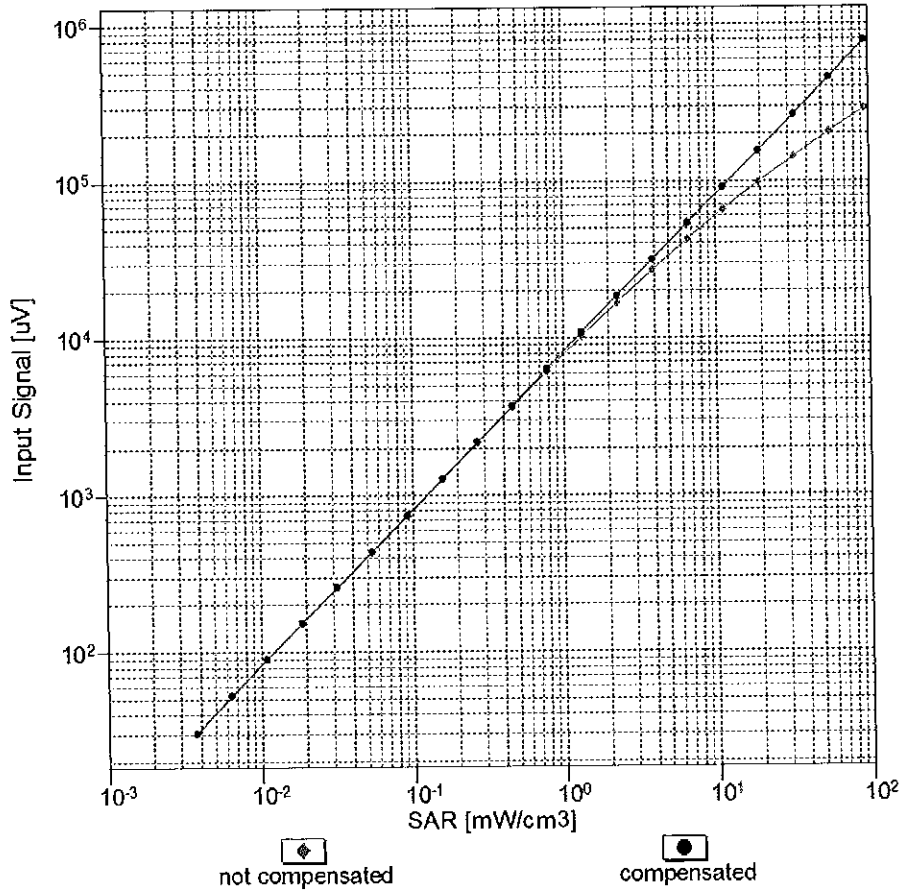

Uncertainty of Linearity Assessment: ± 0.6% (k=2)

Conversion Factor Assessment

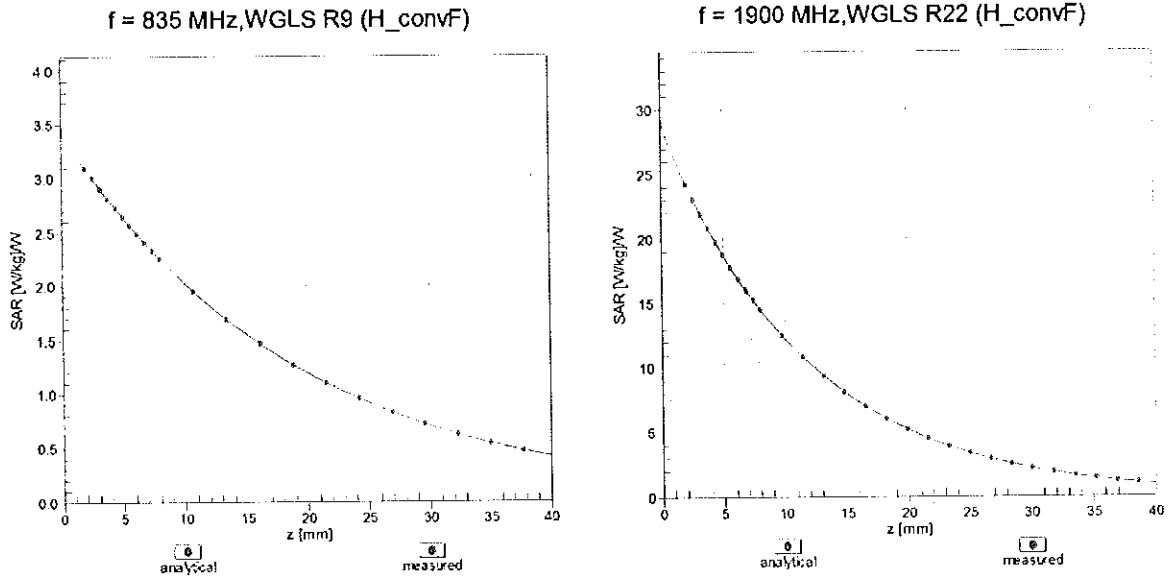

Deviation from Isotropy in Liquid Error (ϕ, θ), f = 900 MHz

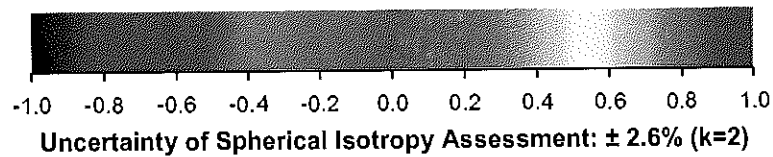
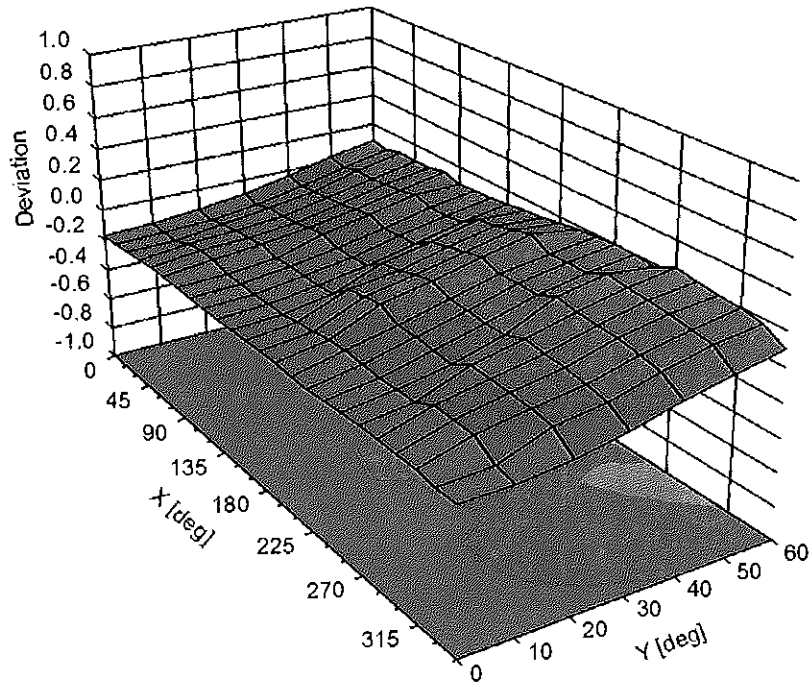

DASY/EASY - Parameters of Probe: ES3DV3 - SN:3209**Other Probe Parameters**

Sensor Arrangement	Triangular
Connector Angle (°)	-39.9
Mechanical Surface Detection Mode	enabled
Optical Surface Detection Mode	disabled
Probe Overall Length	337 mm
Probe Body Diameter	10 mm
Tip Length	10 mm
Tip Diameter	4 mm
Probe Tip to Sensor X Calibration Point	2 mm
Probe Tip to Sensor Y Calibration Point	2 mm
Probe Tip to Sensor Z Calibration Point	2 mm
Recommended Measurement Distance from Surface	3 mm

Appendix: Modulation Calibration Parameters

UID	Communication System Name		A dB	B dB $\sqrt{\mu V}$	C	D dB	VR mV	Max Unc ^E (k=2)
0	CW	X	0.00	0.00	1.00	0.00	185.7	$\pm 3.5\%$
		Y	0.00	0.00	1.00		188.4	
		Z	0.00	0.00	1.00		174.0	
10010- CAA	SAR Validation (Square, 100ms, 10ms)	X	16.56	89.85	21.07	10.00	25.0	$\pm 9.6\%$
		Y	14.18	87.91	20.84		25.0	
		Z	16.46	89.94	21.19		25.0	
10011- CAB	UMTS-FDD (WCDMA)	X	1.31	71.34	17.73	0.00	150.0	$\pm 9.6\%$
		Y	1.07	67.38	15.30		150.0	
		Z	1.14	68.61	16.10		150.0	
10012- CAB	IEEE 802.11b WiFi 2.4 GHz (DSSS, 1 Mbps)	X	1.33	65.77	16.71	0.41	150.0	$\pm 9.6\%$
		Y	1.28	64.69	15.69		150.0	
		Z	1.29	65.03	16.02		150.0	
10013- CAB	IEEE 802.11g WiFi 2.4 GHz (DSSS-OFDM, 6 Mbps)	X	5.11	67.29	17.66	1.46	150.0	$\pm 9.6\%$
		Y	5.08	67.12	17.41		150.0	
		Z	5.08	67.16	17.48		150.0	
10021- DAC	GSM-FDD (TDMA, GMSK)	X	100.00	120.30	31.44	9.39	50.0	$\pm 9.6\%$
		Y	100.00	121.02	32.06		50.0	
		Z	100.00	120.74	31.69		50.0	
10023- DAC	GPRS-FDD (TDMA, GMSK, TN 0)	X	100.00	120.21	31.45	9.57	50.0	$\pm 9.6\%$
		Y	100.00	120.94	32.08		50.0	
		Z	100.00	120.65	31.69		50.0	
10024- DAC	GPRS-FDD (TDMA, GMSK, TN 0-1)	X	100.00	118.31	29.49	6.56	60.0	$\pm 9.6\%$
		Y	100.00	118.38	29.74		60.0	
		Z	100.00	118.51	29.61		60.0	
10025- DAC	EDGE-FDD (TDMA, 8PSK, TN 0)	X	79.79	164.11	61.22	12.57	50.0	$\pm 9.6\%$
		Y	21.03	115.56	45.00		50.0	
		Z	21.02	118.33	46.74		50.0	
10026- DAC	EDGE-FDD (TDMA, 8PSK, TN 0-1)	X	56.10	137.19	47.52	9.56	60.0	$\pm 9.6\%$
		Y	22.58	110.81	38.90		60.0	
		Z	30.67	120.33	42.31		60.0	
10027- DAC	GPRS-FDD (TDMA, GMSK, TN 0-1-2)	X	100.00	118.60	28.85	4.80	80.0	$\pm 9.6\%$
		Y	100.00	117.96	28.73		80.0	
		Z	100.00	118.50	28.81		80.0	
10028- DAC	GPRS-FDD (TDMA, GMSK, TN 0-1-2-3)	X	100.00	120.37	28.91	3.55	100.0	$\pm 9.6\%$
		Y	100.00	118.79	28.36		100.0	
		Z	100.00	119.82	28.67		100.0	
10029- DAC	EDGE-FDD (TDMA, 8PSK, TN 0-1-2)	X	18.11	107.13	37.13	7.80	80.0	$\pm 9.6\%$
		Y	12.22	95.66	32.56		80.0	
		Z	13.69	99.54	34.27		80.0	
10030- CAA	IEEE 802.15.1 Bluetooth (GFSK, DH1)	X	100.00	117.23	28.52	5.30	70.0	$\pm 9.6\%$
		Y	100.00	116.90	28.56		70.0	
		Z	100.00	117.22	28.54		70.0	
10031- CAA	IEEE 802.15.1 Bluetooth (GFSK, DH3)	X	100.00	124.45	29.19	1.88	100.0	$\pm 9.6\%$
		Y	100.00	120.00	27.42		100.0	
		Z	100.00	122.22	28.25		100.0	

10032-CAA	IEEE 802.15.1 Bluetooth (GFSK, DH5)	X	100.00	134.81	32.39	1.17	100.0	± 9.6 %
		Y	100.00	125.40	28.63		100.0	
		Z	100.00	129.61	30.26		100.0	
10033-CAA	IEEE 802.15.1 Bluetooth (PI/4-DQPSK, DH1)	X	100.00	129.27	35.65	5.30	70.0	± 9.6 %
		Y	49.54	115.99	32.11		70.0	
		Z	90.11	126.99	34.97		70.0	
10034-CAA	IEEE 802.15.1 Bluetooth (PI/4-DQPSK, DH3)	X	16.84	102.10	27.13	1.88	100.0	± 9.6 %
		Y	7.82	89.20	22.87		100.0	
		Z	9.48	92.81	24.19		100.0	
10035-CAA	IEEE 802.15.1 Bluetooth (PI/4-DQPSK, DH5)	X	6.67	89.65	23.23	1.17	100.0	± 9.6 %
		Y	3.84	80.35	19.62		100.0	
		Z	4.40	82.90	20.73		100.0	
10036-CAA	IEEE 802.15.1 Bluetooth (8-DPSK, DH1)	X	100.00	129.52	35.77	5.30	70.0	± 9.6 %
		Y	85.34	125.22	34.45		70.0	
		Z	100.00	128.99	35.51		70.0	
10037-CAA	IEEE 802.15.1 Bluetooth (8-DPSK, DH3)	X	15.79	101.19	26.84	1.88	100.0	± 9.6 %
		Y	7.32	88.29	22.54		100.0	
		Z	8.88	91.91	23.88		100.0	
10038-CAA	IEEE 802.15.1 Bluetooth (8-DPSK, DH5)	X	6.96	90.64	23.66	1.17	100.0	± 9.6 %
		Y	3.95	81.00	19.95		100.0	
		Z	4.52	83.60	21.07		100.0	
10039-CAB	CDMA2000 (1xRTT, RC1)	X	2.68	77.46	18.66	0.00	150.0	± 9.6 %
		Y	1.87	71.76	15.92		150.0	
		Z	2.09	73.47	16.81		150.0	
10042-CAB	IS-54 / IS-136 FDD (TDMA/FDM, PI/4-DQPSK, Halfrate)	X	100.00	116.28	28.75	7.78	50.0	± 9.6 %
		Y	100.00	116.68	29.16		50.0	
		Z	100.00	116.58	28.91		50.0	
10044-CAA	IS-91/EIA/TIA-553 FDD (FDMA, FM)	X	0.01	103.03	6.46	0.00	150.0	± 9.6 %
		Y	0.01	95.61	0.65		150.0	
		Z	0.02	122.64	11.17		150.0	
10048-CAA	DECT (TDD, TDMA/FDM, GFSK, Full Slot, 24)	X	100.00	122.27	33.78	13.80	25.0	± 9.6 %
		Y	88.36	120.80	33.95		25.0	
		Z	100.00	122.70	34.06		25.0	
10049-CAA	DECT (TDD, TDMA/FDM, GFSK, Double Slot, 12)	X	100.00	120.46	31.88	10.79	40.0	± 9.6 %
		Y	100.00	121.38	32.63		40.0	
		Z	100.00	120.92	32.14		40.0	
10056-CAA	UMTS-TDD (TD-SCDMA, 1.28 Mcps)	X	64.71	119.17	33.88	9.03	50.0	± 9.6 %
		Y	31.81	105.88	30.24		50.0	
		Z	48.79	114.06	32.52		50.0	
10058-DAC	EDGE-FDD (TDMA, 8PSK, TN 0-1-2-3)	X	10.31	93.78	31.68	6.55	100.0	± 9.6 %
		Y	8.35	87.44	28.76		100.0	
		Z	8.74	89.37	29.77		100.0	
10059-CAB	IEEE 802.11b WiFi 2.4 GHz (DSSS, 2 Mbps)	X	1.47	67.98	17.85	0.61	110.0	± 9.6 %
		Y	1.41	66.57	16.67		110.0	
		Z	1.42	66.96	17.03		110.0	
10060-CAB	IEEE 802.11b WiFi 2.4 GHz (DSSS, 5.5 Mbps)	X	100.00	138.63	36.70	1.30	110.0	± 9.6 %
		Y	100.00	134.16	34.76		110.0	
		Z	100.00	136.34	35.67		110.0	

10061-CAB	IEEE 802.11b WiFi 2.4 GHz (DSSS, 11 Mbps)	X	21.25	113.68	33.06	2.04	110.0	± 9.6 %
		Y	8.67	95.89	27.33		110.0	
		Z	10.38	100.06	28.88		110.0	
10062-CAB	IEEE 802.11a/h WiFi 5 GHz (OFDM, 6 Mbps)	X	4.87	67.16	16.99	0.49	100.0	± 9.6 %
		Y	4.83	66.94	16.72		100.0	
		Z	4.84	67.02	16.80		100.0	
10063-CAB	IEEE 802.11a/h WiFi 5 GHz (OFDM, 9 Mbps)	X	4.90	67.29	17.12	0.72	100.0	± 9.6 %
		Y	4.86	67.08	16.85		100.0	
		Z	4.87	67.15	16.93		100.0	
10064-CAB	IEEE 802.11a/h WiFi 5 GHz (OFDM, 12 Mbps)	X	5.22	67.61	17.38	0.86	100.0	± 9.6 %
		Y	5.17	67.40	17.11		100.0	
		Z	5.19	67.47	17.19		100.0	
10065-CAB	IEEE 802.11a/h WiFi 5 GHz (OFDM, 18 Mbps)	X	5.10	67.59	17.53	1.21	100.0	± 9.6 %
		Y	5.06	67.39	17.27		100.0	
		Z	5.07	67.45	17.34		100.0	
10066-CAB	IEEE 802.11a/h WiFi 5 GHz (OFDM, 24 Mbps)	X	5.14	67.68	17.74	1.46	100.0	± 9.6 %
		Y	5.10	67.48	17.48		100.0	
		Z	5.11	67.54	17.56		100.0	
10067-CAB	IEEE 802.11a/h WiFi 5 GHz (OFDM, 36 Mbps)	X	5.44	67.85	18.21	2.04	100.0	± 9.6 %
		Y	5.41	67.66	17.95		100.0	
		Z	5.41	67.71	18.02		100.0	
10068-CAB	IEEE 802.11a/h WiFi 5 GHz (OFDM, 48 Mbps)	X	5.54	68.11	18.56	2.55	100.0	± 9.6 %
		Y	5.51	67.91	18.28		100.0	
		Z	5.51	67.95	18.36		100.0	
10069-CAB	IEEE 802.11a/h WiFi 5 GHz (OFDM, 54 Mbps)	X	5.62	68.08	18.75	2.67	100.0	± 9.6 %
		Y	5.59	67.88	18.46		100.0	
		Z	5.59	67.92	18.55		100.0	
10071-CAB	IEEE 802.11g WiFi 2.4 GHz (DSSS/OFDM, 9 Mbps)	X	5.23	67.47	18.03	1.99	100.0	± 9.6 %
		Y	5.20	67.30	17.78		100.0	
		Z	5.20	67.34	17.85		100.0	
10072-CAB	IEEE 802.11g WiFi 2.4 GHz (DSSS/OFDM, 12 Mbps)	X	5.25	67.96	18.33	2.30	100.0	± 9.6 %
		Y	5.23	67.77	18.07		100.0	
		Z	5.22	67.81	18.14		100.0	
10073-CAB	IEEE 802.11g WiFi 2.4 GHz (DSSS/OFDM, 18 Mbps)	X	5.35	68.24	18.74	2.83	100.0	± 9.6 %
		Y	5.33	68.06	18.47		100.0	
		Z	5.32	68.08	18.54		100.0	
10074-CAB	IEEE 802.11g WiFi 2.4 GHz (DSSS/OFDM, 24 Mbps)	X	5.35	68.21	18.96	3.30	100.0	± 9.6 %
		Y	5.34	68.06	18.69		100.0	
		Z	5.32	68.06	18.76		100.0	
10075-CAB	IEEE 802.11g WiFi 2.4 GHz (DSSS/OFDM, 36 Mbps)	X	5.45	68.57	19.42	3.82	90.0	± 9.6 %
		Y	5.44	68.40	19.14		90.0	
		Z	5.42	68.40	19.20		90.0	
10076-CAB	IEEE 802.11g WiFi 2.4 GHz (DSSS/OFDM, 48 Mbps)	X	5.44	68.33	19.53	4.15	90.0	± 9.6 %
		Y	5.45	68.18	19.25		90.0	
		Z	5.42	68.16	19.32		90.0	
10077-CAB	IEEE 802.11g WiFi 2.4 GHz (DSSS/OFDM, 54 Mbps)	X	5.47	68.40	19.63	4.30	90.0	± 9.6 %
		Y	5.48	68.26	19.35		90.0	
		Z	5.45	68.24	19.42		90.0	

10081-CAB	CDMA2000 (1xRTT, RC3)	X	1.23	71.08	15.82	0.00	150.0	± 9.6 %
		Y	0.91	66.28	13.04		150.0	
		Z	0.99	67.64	13.91		150.0	
10082-CAB	IS-54 / IS-136 FDD (TDMA/FDM, PI/4-DQPSK, Fullrate)	X	1.44	62.24	7.11	4.77	80.0	± 9.6 %
		Y	1.55	62.44	7.40		80.0	
		Z	1.44	62.17	7.10		80.0	
10090-DAC	GPRS-FDD (TDMA, GMSK, TN 0-4)	X	100.00	118.36	29.54	6.56	60.0	± 9.6 %
		Y	100.00	118.45	29.79		60.0	
		Z	100.00	118.56	29.65		60.0	
10097-CAB	UMTS-FDD (HSDPA)	X	2.01	69.10	16.79	0.00	150.0	± 9.6 %
		Y	1.86	67.49	15.67		150.0	
		Z	1.91	68.05	16.06		150.0	
10098-CAB	UMTS-FDD (HSUPA, Subtest 2)	X	1.98	69.12	16.80	0.00	150.0	± 9.6 %
		Y	1.82	67.46	15.64		150.0	
		Z	1.87	68.03	16.04		150.0	
10099-DAC	EDGE-FDD (TDMA, 8PSK, TN 0-4)	X	56.10	137.12	47.49	9.56	60.0	± 9.6 %
		Y	22.61	110.79	38.89		60.0	
		Z	30.74	120.33	42.30		60.0	
10100-CAC	LTE-FDD (SC-FDMA, 100% RB, 20 MHz, QPSK)	X	3.46	71.82	17.60	0.00	150.0	± 9.6 %
		Y	3.20	70.34	16.69		150.0	
		Z	3.29	70.87	17.01		150.0	
10101-CAC	LTE-FDD (SC-FDMA, 100% RB, 20 MHz, 16-QAM)	X	3.44	68.35	16.55	0.00	150.0	± 9.6 %
		Y	3.33	67.66	16.01		150.0	
		Z	3.37	67.92	16.20		150.0	
10102-CAC	LTE-FDD (SC-FDMA, 100% RB, 20 MHz, 64-QAM)	X	3.53	68.21	16.59	0.00	150.0	± 9.6 %
		Y	3.43	67.60	16.09		150.0	
		Z	3.46	67.83	16.26		150.0	
10103-CAC	LTE-TDD (SC-FDMA, 100% RB, 20 MHz, QPSK)	X	8.71	80.18	22.43	3.98	65.0	± 9.6 %
		Y	8.63	79.54	22.01		65.0	
		Z	8.72	80.06	22.29		65.0	
10104-CAC	LTE-TDD (SC-FDMA, 100% RB, 20 MHz, 16-QAM)	X	8.41	78.26	22.59	3.98	65.0	± 9.6 %
		Y	8.16	77.17	21.90		65.0	
		Z	8.16	77.51	22.15		65.0	
10105-CAC	LTE-TDD (SC-FDMA, 100% RB, 20 MHz, 64-QAM)	X	7.75	76.58	22.19	3.98	65.0	± 9.6 %
		Y	7.29	74.89	21.22		65.0	
		Z	7.40	75.53	21.60		65.0	
10108-CAD	LTE-FDD (SC-FDMA, 100% RB, 10 MHz, QPSK)	X	3.04	71.09	17.48	0.00	150.0	± 9.6 %
		Y	2.81	69.59	16.53		150.0	
		Z	2.89	70.12	16.86		150.0	
10109-CAD	LTE-FDD (SC-FDMA, 100% RB, 10 MHz, 16-QAM)	X	3.10	68.24	16.51	0.00	150.0	± 9.6 %
		Y	2.98	67.47	15.91		150.0	
		Z	3.02	67.76	16.12		150.0	
10110-CAD	LTE-FDD (SC-FDMA, 100% RB, 5 MHz, QPSK)	X	2.51	70.39	17.27	0.00	150.0	± 9.6 %
		Y	2.30	68.71	16.17		150.0	
		Z	2.37	69.29	16.55		150.0	
10111-CAD	LTE-FDD (SC-FDMA, 100% RB, 5 MHz, 16-QAM)	X	2.80	68.98	16.82	0.00	150.0	± 9.6 %
		Y	2.67	68.08	16.14		150.0	
		Z	2.72	68.39	16.37		150.0	

10112-CAD	LTE-FDD (SC-FDMA, 100% RB, 10 MHz, 64-QAM)	X	3.21	68.13	16.51	0.00	150.0	± 9.6 %
		Y	3.11	67.44	15.96		150.0	
		Z	3.14	67.70	16.15		150.0	
10113-CAD	LTE-FDD (SC-FDMA, 100% RB, 5 MHz, 64-QAM)	X	2.94	69.00	16.88	0.00	150.0	± 9.6 %
		Y	2.83	68.20	16.26		150.0	
		Z	2.87	68.48	16.47		150.0	
10114-CAB	IEEE 802.11n (HT Greenfield, 13.5 Mbps, BPSK)	X	5.29	67.60	16.80	0.00	150.0	± 9.6 %
		Y	5.23	67.37	16.54		150.0	
		Z	5.25	67.46	16.62		150.0	
10115-CAB	IEEE 802.11n (HT Greenfield, 81 Mbps, 16-QAM)	X	5.64	67.91	16.97	0.00	150.0	± 9.6 %
		Y	5.58	67.65	16.70		150.0	
		Z	5.60	67.75	16.78		150.0	
10116-CAB	IEEE 802.11n (HT Greenfield, 135 Mbps, 64-QAM)	X	5.42	67.88	16.87	0.00	150.0	± 9.6 %
		Y	5.35	67.63	16.60		150.0	
		Z	5.37	67.72	16.68		150.0	
10117-CAB	IEEE 802.11n (HT Mixed, 13.5 Mbps, BPSK)	X	5.27	67.51	16.78	0.00	150.0	± 9.6 %
		Y	5.21	67.27	16.51		150.0	
		Z	5.23	67.37	16.60		150.0	
10118-CAB	IEEE 802.11n (HT Mixed, 81 Mbps, 16-QAM)	X	5.75	68.18	17.12	0.00	150.0	± 9.6 %
		Y	5.68	67.91	16.83		150.0	
		Z	5.70	68.00	16.92		150.0	
10119-CAB	IEEE 802.11n (HT Mixed, 135 Mbps, 64-QAM)	X	5.39	67.82	16.85	0.00	150.0	± 9.6 %
		Y	5.33	67.57	16.58		150.0	
		Z	5.35	67.66	16.66		150.0	
10140-CAC	LTE-FDD (SC-FDMA, 100% RB, 15 MHz, 16-QAM)	X	3.57	68.23	16.51	0.00	150.0	± 9.6 %
		Y	3.47	67.61	16.01		150.0	
		Z	3.51	67.84	16.19		150.0	
10141-CAC	LTE-FDD (SC-FDMA, 100% RB, 15 MHz, 64-QAM)	X	3.69	68.24	16.63	0.00	150.0	± 9.6 %
		Y	3.59	67.69	16.17		150.0	
		Z	3.63	67.89	16.33		150.0	
10142-CAD	LTE-FDD (SC-FDMA, 100% RB, 3 MHz, QPSK)	X	2.30	70.61	17.13	0.00	150.0	± 9.6 %
		Y	2.07	68.65	15.88		150.0	
		Z	2.15	69.31	16.31		150.0	
10143-CAD	LTE-FDD (SC-FDMA, 100% RB, 3 MHz, 16-QAM)	X	2.70	69.93	16.73	0.00	150.0	± 9.6 %
		Y	2.53	68.73	15.89		150.0	
		Z	2.59	69.14	16.18		150.0	
10144-CAD	LTE-FDD (SC-FDMA, 100% RB, 3 MHz, 64-QAM)	X	2.50	67.93	15.31	0.00	150.0	± 9.6 %
		Y	2.35	66.79	14.47		150.0	
		Z	2.40	67.20	14.77		150.0	
10145-CAD	LTE-FDD (SC-FDMA, 100% RB, 1.4 MHz, QPSK)	X	1.61	68.59	14.32	0.00	150.0	± 9.6 %
		Y	1.36	65.99	12.68		150.0	
		Z	1.44	66.83	13.25		150.0	
10146-CAD	LTE-FDD (SC-FDMA, 100% RB, 1.4 MHz, 16-QAM)	X	4.12	76.15	17.00	0.00	150.0	± 9.6 %
		Y	3.13	71.87	14.86		150.0	
		Z	3.61	74.04	16.00		150.0	
10147-CAD	LTE-FDD (SC-FDMA, 100% RB, 1.4 MHz, 64-QAM)	X	5.91	81.17	19.01	0.00	150.0	± 9.6 %
		Y	4.21	75.86	16.64		150.0	
		Z	5.05	78.62	17.93		150.0	

10149-CAC	LTE-FDD (SC-FDMA, 50% RB, 20 MHz, 16-QAM)	X	3.10	68.30	16.55	0.00	150.0	± 9.6 %
		Y	2.99	67.53	15.95		150.0	
		Z	3.03	67.81	16.16		150.0	
10150-CAC	LTE-FDD (SC-FDMA, 50% RB, 20 MHz, 64-QAM)	X	3.22	68.17	16.55	0.00	150.0	± 9.6 %
		Y	3.11	67.49	16.00		150.0	
		Z	3.15	67.74	16.19		150.0	
10151-CAC	LTE-TDD (SC-FDMA, 50% RB, 20 MHz, QPSK)	X	9.92	84.00	24.01	3.98	65.0	± 9.6 %
		Y	9.28	82.23	23.13		65.0	
		Z	9.42	82.88	23.47		65.0	
10152-CAC	LTE-TDD (SC-FDMA, 50% RB, 20 MHz, 16-QAM)	X	8.12	78.81	22.58	3.98	65.0	± 9.6 %
		Y	7.79	77.46	21.77		65.0	
		Z	7.82	77.90	22.06		65.0	
10153-CAC	LTE-TDD (SC-FDMA, 50% RB, 20 MHz, 64-QAM)	X	8.47	79.51	23.20	3.98	65.0	± 9.6 %
		Y	8.19	78.31	22.47		65.0	
		Z	8.19	78.67	22.72		65.0	
10154-CAD	LTE-FDD (SC-FDMA, 50% RB, 10 MHz, QPSK)	X	2.56	70.77	17.50	0.00	150.0	± 9.6 %
		Y	2.35	69.09	16.42		150.0	
		Z	2.42	69.67	16.79		150.0	
10155-CAD	LTE-FDD (SC-FDMA, 50% RB, 10 MHz, 16-QAM)	X	2.80	68.99	16.83	0.00	150.0	± 9.6 %
		Y	2.68	68.09	16.15		150.0	
		Z	2.72	68.40	16.38		150.0	
10156-CAD	LTE-FDD (SC-FDMA, 50% RB, 5 MHz, QPSK)	X	2.18	71.04	17.14	0.00	150.0	± 9.6 %
		Y	1.92	68.76	15.73		150.0	
		Z	2.01	69.52	16.21		150.0	
10157-CAD	LTE-FDD (SC-FDMA, 50% RB, 5 MHz, 16-QAM)	X	2.37	68.82	15.55	0.00	150.0	± 9.6 %
		Y	2.18	67.35	14.55		150.0	
		Z	2.25	67.86	14.90		150.0	
10158-CAD	LTE-FDD (SC-FDMA, 50% RB, 10 MHz, 64-QAM)	X	2.95	69.05	16.92	0.00	150.0	± 9.6 %
		Y	2.83	68.25	16.30		150.0	
		Z	2.87	68.52	16.51		150.0	
10159-CAD	LTE-FDD (SC-FDMA, 50% RB, 5 MHz, 64-QAM)	X	2.48	69.16	15.77	0.00	150.0	± 9.6 %
		Y	2.29	67.76	14.81		150.0	
		Z	2.35	68.25	15.15		150.0	
10160-CAC	LTE-FDD (SC-FDMA, 50% RB, 15 MHz, QPSK)	X	3.02	70.00	17.21	0.00	150.0	± 9.6 %
		Y	2.84	68.79	16.39		150.0	
		Z	2.90	69.20	16.66		150.0	
10161-CAC	LTE-FDD (SC-FDMA, 50% RB, 15 MHz, 16-QAM)	X	3.11	68.10	16.49	0.00	150.0	± 9.6 %
		Y	3.01	67.41	15.93		150.0	
		Z	3.04	67.66	16.12		150.0	
10162-CAC	LTE-FDD (SC-FDMA, 50% RB, 15 MHz, 64-QAM)	X	3.22	68.18	16.56	0.00	150.0	± 9.6 %
		Y	3.11	67.53	16.02		150.0	
		Z	3.15	67.77	16.21		150.0	
10166-CAD	LTE-FDD (SC-FDMA, 50% RB, 1.4 MHz, QPSK)	X	4.01	71.57	20.55	3.01	150.0	± 9.6 %
		Y	3.96	70.99	19.97		150.0	
		Z	4.00	71.24	20.22		150.0	
10167-CAD	LTE-FDD (SC-FDMA, 50% RB, 1.4 MHz, 16-QAM)	X	5.34	76.03	21.61	3.01	150.0	± 9.6 %
		Y	5.24	75.14	20.90		150.0	
		Z	5.29	75.43	21.17		150.0	

10168-CAD	LTE-FDD (SC-FDMA, 50% RB, 1.4 MHz, 64-QAM)	X	5.92	78.26	22.84	3.01	150.0	± 9.6 %
		Y	5.88	77.64	22.28		150.0	
		Z	5.88	77.74	22.45		150.0	
10169-CAC	LTE-FDD (SC-FDMA, 1 RB, 20 MHz, QPSK)	X	3.56	72.83	21.25	3.01	150.0	± 9.6 %
		Y	3.54	72.03	20.47		150.0	
		Z	3.57	72.33	20.78		150.0	
10170-CAC	LTE-FDD (SC-FDMA, 1 RB, 20 MHz, 16-QAM)	X	5.89	82.52	24.81	3.01	150.0	± 9.6 %
		Y	5.80	81.18	23.85		150.0	
		Z	5.77	81.27	24.06		150.0	
10171-AAC	LTE-FDD (SC-FDMA, 1 RB, 20 MHz, 64-QAM)	X	4.66	77.30	21.81	3.01	150.0	± 9.6 %
		Y	4.48	75.56	20.63		150.0	
		Z	4.56	76.10	21.06		150.0	
10172-CAC	LTE-TDD (SC-FDMA, 1 RB, 20 MHz, QPSK)	X	100.00	142.02	43.67	6.02	65.0	± 9.6 %
		Y	29.14	113.86	35.69		65.0	
		Z	42.14	122.72	38.48		65.0	
10173-CAC	LTE-TDD (SC-FDMA, 1 RB, 20 MHz, 16-QAM)	X	100.00	131.99	38.44	6.02	65.0	± 9.6 %
		Y	100.00	129.98	37.53		65.0	
		Z	100.00	131.24	38.14		65.0	
10174-CAC	LTE-TDD (SC-FDMA, 1 RB, 20 MHz, 64-QAM)	X	100.00	130.14	37.45	6.02	65.0	± 9.6 %
		Y	100.00	127.86	36.41		65.0	
		Z	91.70	127.77	36.74		65.0	
10175-CAD	LTE-FDD (SC-FDMA, 1 RB, 10 MHz, QPSK)	X	3.52	72.50	21.01	3.01	150.0	± 9.6 %
		Y	3.49	71.66	20.21		150.0	
		Z	3.53	71.99	20.53		150.0	
10176-CAD	LTE-FDD (SC-FDMA, 1 RB, 10 MHz, 16-QAM)	X	5.90	82.55	24.82	3.01	150.0	± 9.6 %
		Y	5.81	81.21	23.86		150.0	
		Z	5.78	81.30	24.07		150.0	
10177-CAF	LTE-FDD (SC-FDMA, 1 RB, 5 MHz, QPSK)	X	3.55	72.66	21.10	3.01	150.0	± 9.6 %
		Y	3.52	71.84	20.31		150.0	
		Z	3.56	72.16	20.62		150.0	
10178-CAD	LTE-FDD (SC-FDMA, 1 RB, 5 MHz, 16-QAM)	X	5.82	82.23	24.68	3.01	150.0	± 9.6 %
		Y	5.72	80.87	23.70		150.0	
		Z	5.70	80.99	23.93		150.0	
10179-CAD	LTE-FDD (SC-FDMA, 1 RB, 10 MHz, 64-QAM)	X	5.25	79.82	23.19	3.01	150.0	± 9.6 %
		Y	5.07	78.18	22.08		150.0	
		Z	5.12	78.56	22.43		150.0	
10180-CAD	LTE-FDD (SC-FDMA, 1 RB, 5 MHz, 64-QAM)	X	4.65	77.21	21.76	3.01	150.0	± 9.6 %
		Y	4.46	75.45	20.57		150.0	
		Z	4.54	76.00	21.00		150.0	
10181-CAC	LTE-FDD (SC-FDMA, 1 RB, 15 MHz, QPSK)	X	3.55	72.65	21.10	3.01	150.0	± 9.6 %
		Y	3.51	71.82	20.30		150.0	
		Z	3.55	72.14	20.62		150.0	
10182-CAC	LTE-FDD (SC-FDMA, 1 RB, 15 MHz, 16-QAM)	X	5.81	82.20	24.67	3.01	150.0	± 9.6 %
		Y	5.71	80.84	23.69		150.0	
		Z	5.69	80.96	23.92		150.0	
10183-AAB	LTE-FDD (SC-FDMA, 1 RB, 15 MHz, 64-QAM)	X	4.64	77.18	21.74	3.01	150.0	± 9.6 %
		Y	4.45	75.42	20.56		150.0	
		Z	4.53	75.97	20.99		150.0	

10184-CAD	LTE-FDD (SC-FDMA, 1 RB, 3 MHz, QPSK)	X	3.56	72.69	21.12	3.01	150.0	± 9.6 %
		Y	3.53	71.87	20.33		150.0	
		Z	3.57	72.19	20.64		150.0	
10185-CAD	LTE-FDD (SC-FDMA, 1 RB, 3 MHz, 16-QAM)	X	5.84	82.29	24.71	3.01	150.0	± 9.6 %
		Y	5.74	80.94	23.73		150.0	
		Z	5.72	81.05	23.96		150.0	
10186-AAD	LTE-FDD (SC-FDMA, 1 RB, 3 MHz, 64-QAM)	X	4.67	77.27	21.78	3.01	150.0	± 9.6 %
		Y	4.47	75.51	20.59		150.0	
		Z	4.56	76.06	21.03		150.0	
10187-CAD	LTE-FDD (SC-FDMA, 1 RB, 1.4 MHz, QPSK)	X	3.57	72.74	21.18	3.01	150.0	± 9.6 %
		Y	3.54	71.92	20.39		150.0	
		Z	3.58	72.24	20.70		150.0	
10188-CAD	LTE-FDD (SC-FDMA, 1 RB, 1.4 MHz, 16-QAM)	X	6.08	83.16	25.13	3.01	150.0	± 9.6 %
		Y	6.00	81.87	24.19		150.0	
		Z	5.95	81.90	24.38		150.0	
10189-AAD	LTE-FDD (SC-FDMA, 1 RB, 1.4 MHz, 64-QAM)	X	4.80	77.83	22.09	3.01	150.0	± 9.6 %
		Y	4.61	76.08	20.92		150.0	
		Z	4.69	76.60	21.33		150.0	
10193-CAB	IEEE 802.11n (HT Greenfield, 6.5 Mbps, BPSK)	X	4.68	66.98	16.53	0.00	150.0	± 9.6 %
		Y	4.62	66.73	16.24		150.0	
		Z	4.64	66.83	16.34		150.0	
10194-CAB	IEEE 802.11n (HT Greenfield, 39 Mbps, 16-QAM)	X	4.86	67.32	16.65	0.00	150.0	± 9.6 %
		Y	4.81	67.07	16.37		150.0	
		Z	4.83	67.17	16.46		150.0	
10195-CAB	IEEE 802.11n (HT Greenfield, 65 Mbps, 64-QAM)	X	4.91	67.35	16.66	0.00	150.0	± 9.6 %
		Y	4.85	67.10	16.38		150.0	
		Z	4.87	67.20	16.47		150.0	
10196-CAB	IEEE 802.11n (HT Mixed, 6.5 Mbps, BPSK)	X	4.69	67.06	16.56	0.00	150.0	± 9.6 %
		Y	4.63	66.81	16.27		150.0	
		Z	4.65	66.91	16.37		150.0	
10197-CAB	IEEE 802.11n (HT Mixed, 39 Mbps, 16-QAM)	X	4.88	67.35	16.66	0.00	150.0	± 9.6 %
		Y	4.82	67.09	16.38		150.0	
		Z	4.84	67.19	16.47		150.0	
10198-CAB	IEEE 802.11n (HT Mixed, 65 Mbps, 64-QAM)	X	4.91	67.37	16.68	0.00	150.0	± 9.6 %
		Y	4.85	67.12	16.39		150.0	
		Z	4.87	67.22	16.49		150.0	
10219-CAB	IEEE 802.11n (HT Mixed, 7.2 Mbps, BPSK)	X	4.64	67.08	16.52	0.00	150.0	± 9.6 %
		Y	4.58	66.82	16.23		150.0	
		Z	4.60	66.92	16.33		150.0	
10220-CAB	IEEE 802.11n (HT Mixed, 43.3 Mbps, 16-QAM)	X	4.88	67.33	16.66	0.00	150.0	± 9.6 %
		Y	4.82	67.07	16.37		150.0	
		Z	4.84	67.17	16.47		150.0	
10221-CAB	IEEE 802.11n (HT Mixed, 72.2 Mbps, 64-QAM)	X	4.92	67.29	16.66	0.00	150.0	± 9.6 %
		Y	4.86	67.05	16.38		150.0	
		Z	4.88	67.14	16.47		150.0	
10222-CAB	IEEE 802.11n (HT Mixed, 15 Mbps, BPSK)	X	5.24	67.52	16.77	0.00	150.0	± 9.6 %
		Y	5.18	67.28	16.51		150.0	
		Z	5.21	67.38	16.59		150.0	

10223-CAB	IEEE 802.11n (HT Mixed, 90 Mbps, 16-QAM)	X	5.57	67.76	16.92	0.00	150.0	± 9.6 %
		Y	5.51	67.51	16.65		150.0	
		Z	5.53	67.60	16.73		150.0	
10224-CAB	IEEE 802.11n (HT Mixed, 150 Mbps, 64-QAM)	X	5.29	67.62	16.75	0.00	150.0	± 9.6 %
		Y	5.23	67.38	16.48		150.0	
		Z	5.25	67.47	16.57		150.0	
10225-CAB	UMTS-FDD (HSPA+)	X	2.96	66.72	15.94	0.00	150.0	± 9.6 %
		Y	2.88	66.18	15.44		150.0	
		Z	2.91	66.38	15.61		150.0	
10226-CAA	LTE-TDD (SC-FDMA, 1 RB, 1.4 MHz, 16-QAM)	X	100.00	132.19	38.58	6.02	65.0	± 9.6 %
		Y	100.00	130.20	37.67		65.0	
		Z	100.00	131.44	38.27		65.0	
10227-CAA	LTE-TDD (SC-FDMA, 1 RB, 1.4 MHz, 64-QAM)	X	100.00	129.74	37.30	6.02	65.0	± 9.6 %
		Y	100.00	127.95	36.49		65.0	
		Z	100.00	129.11	37.05		65.0	
10228-CAA	LTE-TDD (SC-FDMA, 1 RB, 1.4 MHz, QPSK)	X	100.00	141.90	43.60	6.02	65.0	± 9.6 %
		Y	64.28	130.08	40.04		65.0	
		Z	94.90	139.78	42.86		65.0	
10229-CAB	LTE-TDD (SC-FDMA, 1 RB, 3 MHz, 16-QAM)	X	100.00	131.97	38.44	6.02	65.0	± 9.6 %
		Y	100.00	129.97	37.54		65.0	
		Z	100.00	131.22	38.14		65.0	
10230-CAB	LTE-TDD (SC-FDMA, 1 RB, 3 MHz, 64-QAM)	X	100.00	129.60	37.20	6.02	65.0	± 9.6 %
		Y	100.00	127.79	36.39		65.0	
		Z	100.00	128.96	36.95		65.0	
10231-CAB	LTE-TDD (SC-FDMA, 1 RB, 3 MHz, QPSK)	X	100.00	141.75	43.50	6.02	65.0	± 9.6 %
		Y	57.85	127.76	39.37		65.0	
		Z	84.57	137.19	42.14		65.0	
10232-CAC	LTE-TDD (SC-FDMA, 1 RB, 5 MHz, 16-QAM)	X	100.00	131.99	38.45	6.02	65.0	± 9.6 %
		Y	100.00	129.98	37.54		65.0	
		Z	100.00	131.24	38.14		65.0	
10233-CAC	LTE-TDD (SC-FDMA, 1 RB, 5 MHz, 64-QAM)	X	100.00	129.61	37.21	6.02	65.0	± 9.6 %
		Y	100.00	127.81	36.39		65.0	
		Z	100.00	128.97	36.95		65.0	
10234-CAC	LTE-TDD (SC-FDMA, 1 RB, 5 MHz, QPSK)	X	100.00	141.44	43.31	6.02	65.0	± 9.6 %
		Y	52.53	125.50	38.67		65.0	
		Z	75.93	134.62	41.39		65.0	
10235-CAC	LTE-TDD (SC-FDMA, 1 RB, 10 MHz, 16-QAM)	X	100.00	132.00	38.45	6.02	65.0	± 9.6 %
		Y	100.00	130.00	37.54		65.0	
		Z	100.00	131.25	38.15		65.0	
10236-CAC	LTE-TDD (SC-FDMA, 1 RB, 10 MHz, 64-QAM)	X	100.00	129.56	37.18	6.02	65.0	± 9.6 %
		Y	100.00	127.76	36.37		65.0	
		Z	100.00	128.92	36.93		65.0	
10237-CAC	LTE-TDD (SC-FDMA, 1 RB, 10 MHz, QPSK)	X	100.00	141.78	43.50	6.02	65.0	± 9.6 %
		Y	58.86	128.14	39.47		65.0	
		Z	86.67	137.73	42.28		65.0	
10238-CAC	LTE-TDD (SC-FDMA, 1 RB, 15 MHz, 16-QAM)	X	100.00	132.00	38.45	6.02	65.0	± 9.6 %
		Y	100.00	129.99	37.54		65.0	
		Z	100.00	131.25	38.14		65.0	

10239-CAC	LTE-TDD (SC-FDMA, 1 RB, 15 MHz, 64-QAM)	X	100.00	129.64	37.21	6.02	65.0	± 9.6 %
		Y	100.00	127.83	36.40		65.0	
		Z	100.00	129.00	36.96		65.0	
10240-CAC	LTE-TDD (SC-FDMA, 1 RB, 15 MHz, QPSK)	X	100.00	141.80	43.51	6.02	65.0	± 9.6 %
		Y	58.51	128.03	39.44		65.0	
		Z	86.02	137.59	42.24		65.0	
10241-CAA	LTE-TDD (SC-FDMA, 50% RB, 1.4 MHz, 16-QAM)	X	13.65	92.13	30.26	6.98	65.0	± 9.6 %
		Y	12.73	89.47	28.84		65.0	
		Z	12.83	90.19	29.33		65.0	
10242-CAA	LTE-TDD (SC-FDMA, 50% RB, 1.4 MHz, 64-QAM)	X	11.56	88.33	28.75	6.98	65.0	± 9.6 %
		Y	12.17	88.47	28.39		65.0	
		Z	10.55	85.79	27.57		65.0	
10243-CAA	LTE-TDD (SC-FDMA, 50% RB, 1.4 MHz, QPSK)	X	8.75	83.84	28.04	6.98	65.0	± 9.6 %
		Y	9.16	83.97	27.64		65.0	
		Z	8.20	81.83	26.97		65.0	
10244-CAB	LTE-TDD (SC-FDMA, 50% RB, 3 MHz, 16-QAM)	X	11.15	85.22	22.92	3.98	65.0	± 9.6 %
		Y	10.49	83.51	22.06		65.0	
		Z	10.74	84.39	22.53		65.0	
10245-CAB	LTE-TDD (SC-FDMA, 50% RB, 3 MHz, 64-QAM)	X	10.71	84.28	22.53	3.98	65.0	± 9.6 %
		Y	10.12	82.65	21.69		65.0	
		Z	10.34	83.48	22.15		65.0	
10246-CAB	LTE-TDD (SC-FDMA, 50% RB, 3 MHz, QPSK)	X	11.99	89.44	24.35	3.98	65.0	± 9.6 %
		Y	10.01	85.73	22.85		65.0	
		Z	10.59	87.16	23.46		65.0	
10247-CAC	LTE-TDD (SC-FDMA, 50% RB, 5 MHz, 16-QAM)	X	7.78	79.88	21.56	3.98	65.0	± 9.6 %
		Y	7.39	78.44	20.77		65.0	
		Z	7.42	78.92	21.06		65.0	
10248-CAC	LTE-TDD (SC-FDMA, 50% RB, 5 MHz, 64-QAM)	X	7.68	79.17	21.27	3.98	65.0	± 9.6 %
		Y	7.29	77.74	20.47		65.0	
		Z	7.33	78.22	20.77		65.0	
10249-CAC	LTE-TDD (SC-FDMA, 50% RB, 5 MHz, QPSK)	X	13.65	92.24	26.09	3.98	65.0	± 9.6 %
		Y	11.34	88.25	24.50		65.0	
		Z	12.01	89.77	25.14		65.0	
10250-CAC	LTE-TDD (SC-FDMA, 50% RB, 10 MHz, 16-QAM)	X	8.65	81.91	23.79	3.98	65.0	± 9.6 %
		Y	8.26	80.45	22.98		65.0	
		Z	8.27	80.90	23.26		65.0	
10251-CAC	LTE-TDD (SC-FDMA, 50% RB, 10 MHz, 64-QAM)	X	8.08	79.43	22.51	3.98	65.0	± 9.6 %
		Y	7.71	78.00	21.68		65.0	
		Z	7.74	78.46	21.99		65.0	
10252-CAC	LTE-TDD (SC-FDMA, 50% RB, 10 MHz, QPSK)	X	11.90	89.42	25.97	3.98	65.0	± 9.6 %
		Y	10.50	86.42	24.67		65.0	
		Z	10.87	87.52	25.18		65.0	
10253-CAC	LTE-TDD (SC-FDMA, 50% RB, 15 MHz, 16-QAM)	X	7.84	78.03	22.28	3.98	65.0	± 9.6 %
		Y	7.57	76.80	21.51		65.0	
		Z	7.57	77.19	21.79		65.0	
10254-CAC	LTE-TDD (SC-FDMA, 50% RB, 15 MHz, 64-QAM)	X	8.21	78.77	22.87	3.98	65.0	± 9.6 %
		Y	7.97	77.64	22.16		65.0	
		Z	7.95	77.97	22.41		65.0	

10255- CAC	LTE-TDD (SC-FDMA, 50% RB, 15 MHz, QPSK)	X	9.44	83.41	24.04	3.98	65.0	± 9.6 %
		Y	8.86	81.64	23.14		65.0	
		Z	8.96	82.26	23.48		65.0	
10256- CAA	LTE-TDD (SC-FDMA, 100% RB, 1.4 MHz, 16-QAM)	X	9.33	81.69	20.68	3.98	65.0	± 9.6 %
		Y	8.73	79.97	19.81		65.0	
		Z	9.01	80.96	20.33		65.0	
10257- CAA	LTE-TDD (SC-FDMA, 100% RB, 1.4 MHz, 64-QAM)	X	8.80	80.36	20.09	3.98	65.0	± 9.6 %
		Y	8.27	78.77	19.26		65.0	
		Z	8.51	79.68	19.75		65.0	
10258- CAA	LTE-TDD (SC-FDMA, 100% RB, 1.4 MHz, QPSK)	X	9.10	84.22	21.80	3.98	65.0	± 9.6 %
		Y	7.87	81.28	20.53		65.0	
		Z	8.20	82.41	21.04		65.0	
10259- CAB	LTE-TDD (SC-FDMA, 100% RB, 3 MHz, 16-QAM)	X	8.13	80.62	22.35	3.98	65.0	± 9.6 %
		Y	7.73	79.15	21.54		65.0	
		Z	7.76	79.63	21.84		65.0	
10260- CAB	LTE-TDD (SC-FDMA, 100% RB, 3 MHz, 64-QAM)	X	8.07	80.16	22.18	3.98	65.0	± 9.6 %
		Y	7.70	78.77	21.40		65.0	
		Z	7.73	79.22	21.69		65.0	
10261- CAB	LTE-TDD (SC-FDMA, 100% RB, 3 MHz, QPSK)	X	11.98	89.88	25.68	3.98	65.0	± 9.6 %
		Y	10.32	86.47	24.25		65.0	
		Z	10.77	87.74	24.81		65.0	
10262- CAC	LTE-TDD (SC-FDMA, 100% RB, 5 MHz, 16-QAM)	X	8.64	81.87	23.76	3.98	65.0	± 9.6 %
		Y	8.25	80.40	22.94		65.0	
		Z	8.26	80.85	23.23		65.0	
10263- CAC	LTE-TDD (SC-FDMA, 100% RB, 5 MHz, 64-QAM)	X	8.06	79.41	22.51	3.98	65.0	± 9.6 %
		Y	7.70	77.98	21.68		65.0	
		Z	7.73	78.44	21.98		65.0	
10264- CAC	LTE-TDD (SC-FDMA, 100% RB, 5 MHz, QPSK)	X	11.79	89.22	25.88	3.98	65.0	± 9.6 %
		Y	10.40	86.22	24.58		65.0	
		Z	10.77	87.33	25.09		65.0	
10265- CAC	LTE-TDD (SC-FDMA, 100% RB, 10 MHz, 16-QAM)	X	8.12	78.81	22.58	3.98	65.0	± 9.6 %
		Y	7.79	77.46	21.77		65.0	
		Z	7.81	77.90	22.07		65.0	
10266- CAC	LTE-TDD (SC-FDMA, 100% RB, 10 MHz, 64-QAM)	X	8.47	79.50	23.19	3.98	65.0	± 9.6 %
		Y	8.19	78.30	22.46		65.0	
		Z	8.19	78.66	22.72		65.0	
10267- CAC	LTE-TDD (SC-FDMA, 100% RB, 10 MHz, QPSK)	X	9.89	83.95	23.99	3.98	65.0	± 9.6 %
		Y	9.26	82.18	23.11		65.0	
		Z	9.39	82.83	23.45		65.0	
10268- CAC	LTE-TDD (SC-FDMA, 100% RB, 15 MHz, 16-QAM)	X	8.44	77.80	22.53	3.98	65.0	± 9.6 %
		Y	8.24	76.84	21.89		65.0	
		Z	8.22	77.13	22.11		65.0	
10269- CAC	LTE-TDD (SC-FDMA, 100% RB, 15 MHz, 64-QAM)	X	8.33	77.26	22.37	3.98	65.0	± 9.6 %
		Y	8.15	76.36	21.76		65.0	
		Z	8.12	76.62	21.97		65.0	
10270- CAC	LTE-TDD (SC-FDMA, 100% RB, 15 MHz, QPSK)	X	8.75	79.75	22.52	3.98	65.0	± 9.6 %
		Y	8.49	78.72	21.92		65.0	
		Z	8.50	79.07	22.14		65.0	

10274-CAB	UMTS-FDD (HSUPA, Subtest 5, 3GPP Rel8.10)	X	2.73	67.18	15.92	0.00	150.0	± 9.6 %
		Y	2.64	66.46	15.31		150.0	
		Z	2.68	66.73	15.52		150.0	
10275-CAB	UMTS-FDD (HSUPA, Subtest 5, 3GPP Rel8.4)	X	1.87	70.21	17.08	0.00	150.0	± 9.6 %
		Y	1.66	67.87	15.58		150.0	
		Z	1.73	68.66	16.09		150.0	
10277-CAA	PHS (QPSK)	X	3.84	66.56	11.27	9.03	50.0	± 9.6 %
		Y	4.12	66.98	11.68		50.0	
		Z	3.85	66.55	11.29		50.0	
10278-CAA	PHS (QPSK, BW 884MHz, Rolloff 0.5)	X	11.65	86.02	22.30	9.03	50.0	± 9.6 %
		Y	10.21	83.31	21.39		50.0	
		Z	10.96	84.97	21.93		50.0	
10279-CAA	PHS (QPSK, BW 884MHz, Rolloff 0.38)	X	11.92	86.31	22.44	9.03	50.0	± 9.6 %
		Y	10.38	83.50	21.49		50.0	
		Z	11.18	85.20	22.04		50.0	
10290-AAB	CDMA2000, RC1, SO55, Full Rate	X	2.05	73.37	16.75	0.00	150.0	± 9.6 %
		Y	1.54	68.94	14.39		150.0	
		Z	1.68	70.29	15.17		150.0	
10291-AAB	CDMA2000, RC3, SO55, Full Rate	X	1.19	70.69	15.63	0.00	150.0	± 9.6 %
		Y	0.89	66.06	12.92		150.0	
		Z	0.97	67.37	13.76		150.0	
10292-AAB	CDMA2000, RC3, SO32, Full Rate	X	1.82	77.98	19.13	0.00	150.0	± 9.6 %
		Y	1.09	69.78	15.12		150.0	
		Z	1.26	72.00	16.33		150.0	
10293-AAB	CDMA2000, RC3, SO3, Full Rate	X	3.13	86.75	22.80	0.00	150.0	± 9.6 %
		Y	1.53	74.84	17.78		150.0	
		Z	1.85	77.92	19.23		150.0	
10295-AAB	CDMA2000, RC1, SO3, 1/8th Rate 25 fr.	X	16.24	95.47	28.50	9.03	50.0	± 9.6 %
		Y	13.39	90.69	26.64		50.0	
		Z	14.20	92.62	27.44		50.0	
10297-AAB	LTE-FDD (SC-FDMA, 50% RB, 20 MHz, QPSK)	X	3.05	71.18	17.54	0.00	150.0	± 9.6 %
		Y	2.82	69.68	16.59		150.0	
		Z	2.90	70.21	16.92		150.0	
10298-AAC	LTE-FDD (SC-FDMA, 50% RB, 3 MHz, QPSK)	X	1.96	70.66	16.14	0.00	150.0	± 9.6 %
		Y	1.66	67.94	14.50		150.0	
		Z	1.76	68.83	15.06		150.0	
10299-AAC	LTE-FDD (SC-FDMA, 50% RB, 3 MHz, 16-QAM)	X	4.77	78.24	18.75	0.00	150.0	± 9.6 %
		Y	3.92	74.76	16.99		150.0	
		Z	4.32	76.42	17.88		150.0	
10300-AAC	LTE-FDD (SC-FDMA, 50% RB, 3 MHz, 64-QAM)	X	3.00	70.52	14.82	0.00	150.0	± 9.6 %
		Y	2.63	68.29	13.44		150.0	
		Z	2.81	69.37	14.14		150.0	
10301-AAA	IEEE 802.16e WiMAX (29:18, 5ms, 10MHz, QPSK, PUSC)	X	5.51	68.11	19.09	4.17	80.0	± 9.6 %
		Y	5.33	67.16	18.33		80.0	
		Z	5.40	67.58	18.66		80.0	
10302-AAA	IEEE 802.16e WiMAX (29:18, 5ms, 10MHz, QPSK, PUSC, 3 CTRL symbols)	X	5.91	68.43	19.68	4.96	80.0	± 9.6 %
		Y	5.80	67.70	19.02		80.0	
		Z	5.81	67.92	19.25		80.0	

10303-AAA	IEEE 802.16e WiMAX (31:15, 5ms, 10MHz, 64QAM, PUSC)	X	5.70	68.33	19.67	4.96	80.0	± 9.6 %
		Y	5.59	67.57	18.98		80.0	
		Z	5.60	67.78	19.21		80.0	
10304-AAA	IEEE 802.16e WiMAX (29:18, 5ms, 10MHz, 64QAM, PUSC)	X	5.41	67.77	18.89	4.17	80.0	± 9.6 %
		Y	5.31	67.11	18.28		80.0	
		Z	5.33	67.30	18.48		80.0	
10305-AAA	IEEE 802.16e WiMAX (31:15, 10ms, 10MHz, 64QAM, PUSC, 15 symbols)	X	6.16	75.00	23.87	6.02	50.0	± 9.6 %
		Y	6.03	73.79	22.78		50.0	
		Z	5.90	73.64	22.94		50.0	
10306-AAA	IEEE 802.16e WiMAX (29:18, 10ms, 10MHz, 64QAM, PUSC, 18 symbols)	X	5.76	70.24	21.37	6.02	50.0	± 9.6 %
		Y	5.59	69.03	20.35		50.0	
		Z	5.60	69.33	20.68		50.0	
10307-AAA	IEEE 802.16e WiMAX (29:18, 10ms, 10MHz, QPSK, PUSC, 18 symbols)	X	5.75	70.76	21.47	6.02	50.0	± 9.6 %
		Y	5.78	71.13	21.51		50.0	
		Z	5.57	69.74	20.73		50.0	
10308-AAA	IEEE 802.16e WiMAX (29:18, 10ms, 10MHz, 16QAM, PUSC)	X	5.77	71.12	21.68	6.02	50.0	± 9.6 %
		Y	5.80	71.54	21.74		50.0	
		Z	5.57	70.05	20.90		50.0	
10309-AAA	IEEE 802.16e WiMAX (29:18, 10ms, 10MHz, 16QAM, AMC 2x3, 18 symbols)	X	5.87	70.63	21.59	6.02	50.0	± 9.6 %
		Y	5.68	69.33	20.52		50.0	
		Z	5.69	69.66	20.87		50.0	
10310-AAA	IEEE 802.16e WiMAX (29:18, 10ms, 10MHz, QPSK, AMC 2x3, 18 symbols)	X	5.74	70.42	21.38	6.02	50.0	± 9.6 %
		Y	5.56	69.17	20.34		50.0	
		Z	5.57	69.47	20.67		50.0	
10311-AAB	LTE-FDD (SC-FDMA, 100% RB, 15 MHz, QPSK)	X	3.41	70.28	17.06	0.00	150.0	± 9.6 %
		Y	3.18	68.96	16.24		150.0	
		Z	3.26	69.44	16.53		150.0	
10313-AAA	iDEN 1:3	X	11.93	87.85	22.00	6.99	70.0	± 9.6 %
		Y	8.95	83.03	20.34		70.0	
		Z	9.92	85.08	21.06		70.0	
10314-AAA	iDEN 1:6	X	19.66	101.09	29.03	10.00	30.0	± 9.6 %
		Y	13.64	93.68	26.63		30.0	
		Z	14.94	96.21	27.54		30.0	
10315-AAB	IEEE 802.11b WiFi 2.4 GHz (DSSS, 1 Mbps, 96pc duty cycle)	X	1.20	65.36	16.48	0.17	150.0	± 9.6 %
		Y	1.15	64.26	15.42		150.0	
		Z	1.17	64.62	15.77		150.0	
10316-AAB	IEEE 802.11g WiFi 2.4 GHz (ERP-OFDM, 6 Mbps, 96pc duty cycle)	X	4.76	67.14	16.74	0.17	150.0	± 9.6 %
		Y	4.71	66.90	16.45		150.0	
		Z	4.73	66.99	16.55		150.0	
10317-AAB	IEEE 802.11a WiFi 5 GHz (OFDM, 6 Mbps, 96pc duty cycle)	X	4.76	67.14	16.74	0.17	150.0	± 9.6 %
		Y	4.71	66.90	16.45		150.0	
		Z	4.73	66.99	16.55		150.0	
10400-AAC	IEEE 802.11ac WiFi (20MHz, 64-QAM, 99pc duty cycle)	X	4.87	67.43	16.68	0.00	150.0	± 9.6 %
		Y	4.81	67.14	16.37		150.0	
		Z	4.83	67.26	16.47		150.0	
10401-AAC	IEEE 802.11ac WiFi (40MHz, 64-QAM, 99pc duty cycle)	X	5.57	67.64	16.85	0.00	150.0	± 9.6 %
		Y	5.51	67.40	16.57		150.0	
		Z	5.53	67.48	16.66		150.0	

10402-AAC	IEEE 802.11ac WiFi (80MHz, 64-QAM, 99pc duty cycle)	X	5.83	67.94	16.82	0.00	150.0	± 9.6 %
		Y	5.77	67.71	16.58		150.0	
		Z	5.79	67.80	16.65		150.0	
10403-AAB	CDMA2000 (1xEV-DO, Rev. 0)	X	2.05	73.37	16.75	0.00	115.0	± 9.6 %
		Y	1.54	68.94	14.39		115.0	
		Z	1.68	70.29	15.17		115.0	
10404-AAB	CDMA2000 (1xEV-DO, Rev. A)	X	2.05	73.37	16.75	0.00	115.0	± 9.6 %
		Y	1.54	68.94	14.39		115.0	
		Z	1.68	70.29	15.17		115.0	
10406-AAB	CDMA2000, RC3, SO32, SCH0, Full Rate	X	100.00	124.58	31.94	0.00	100.0	± 9.6 %
		Y	100.00	121.04	30.37		100.0	
		Z	100.00	123.01	31.32		100.0	
10410-AAB	LTE-TDD (SC-FDMA, 1 RB, 10 MHz, QPSK, UL Subframe=2,3,4,7,8,9)	X	100.00	125.25	32.53	3.23	80.0	± 9.6 %
		Y	100.00	122.76	31.43		80.0	
		Z	100.00	124.49	32.22		80.0	
10415-AAA	IEEE 802.11b WiFi 2.4 GHz (DSSS, 1 Mbps, 99pc duty cycle)	X	1.07	64.01	15.66	0.00	150.0	± 9.6 %
		Y	1.03	63.00	14.62		150.0	
		Z	1.05	63.37	14.98		150.0	
10416-AAA	IEEE 802.11g WiFi 2.4 GHz (ERP-OFDM, 6 Mbps, 99pc duty cycle)	X	4.68	67.03	16.59	0.00	150.0	± 9.6 %
		Y	4.63	66.78	16.30		150.0	
		Z	4.65	66.88	16.40		150.0	
10417-AAA	IEEE 802.11a/h WiFi 5 GHz (OFDM, 6 Mbps, 99pc duty cycle)	X	4.68	67.03	16.59	0.00	150.0	± 9.6 %
		Y	4.63	66.78	16.30		150.0	
		Z	4.65	66.88	16.40		150.0	
10418-AAA	IEEE 802.11g WiFi 2.4 GHz (DSSS-OFDM, 6 Mbps, 99pc duty cycle, Long preamble)	X	4.67	67.18	16.60	0.00	150.0	± 9.6 %
		Y	4.61	66.92	16.31		150.0	
		Z	4.64	67.02	16.41		150.0	
10419-AAA	IEEE 802.11g WiFi 2.4 GHz (DSSS-OFDM, 6 Mbps, 99pc duty cycle, Short preamble)	X	4.69	67.13	16.61	0.00	150.0	± 9.6 %
		Y	4.64	66.87	16.32		150.0	
		Z	4.66	66.98	16.42		150.0	
10422-AAA	IEEE 802.11n (HT Greenfield, 7.2 Mbps, BPSK)	X	4.82	67.13	16.62	0.00	150.0	± 9.6 %
		Y	4.76	66.89	16.34		150.0	
		Z	4.78	66.98	16.43		150.0	
10423-AAA	IEEE 802.11n (HT Greenfield, 43.3 Mbps, 16-QAM)	X	5.00	67.48	16.75	0.00	150.0	± 9.6 %
		Y	4.94	67.23	16.47		150.0	
		Z	4.96	67.33	16.56		150.0	
10424-AAA	IEEE 802.11n (HT Greenfield, 72.2 Mbps, 64-QAM)	X	4.92	67.43	16.72	0.00	150.0	± 9.6 %
		Y	4.86	67.17	16.43		150.0	
		Z	4.88	67.27	16.53		150.0	
10425-AAA	IEEE 802.11n (HT Greenfield, 15 Mbps, BPSK)	X	5.54	67.85	16.94	0.00	150.0	± 9.6 %
		Y	5.48	67.60	16.67		150.0	
		Z	5.50	67.69	16.75		150.0	
10426-AAA	IEEE 802.11n (HT Greenfield, 90 Mbps, 16-QAM)	X	5.55	67.86	16.94	0.00	150.0	± 9.6 %
		Y	5.48	67.61	16.67		150.0	
		Z	5.50	67.70	16.75		150.0	

10427-AAA	IEEE 802.11n (HT Greenfield, 150 Mbps, 64-QAM)	X	5.55	67.81	16.91	0.00	150.0	± 9.6 %
		Y	5.49	67.57	16.65		150.0	
		Z	5.51	67.66	16.73		150.0	
10430-AAA	LTE-FDD (OFDMA, 5 MHz, E-TM 3.1)	X	4.30	70.44	18.21	0.00	150.0	± 9.6 %
		Y	4.27	70.38	18.04		150.0	
		Z	4.27	70.33	18.05		150.0	
10431-AAA	LTE-FDD (OFDMA, 10 MHz, E-TM 3.1)	X	4.40	67.65	16.65	0.00	150.0	± 9.6 %
		Y	4.32	67.31	16.31		150.0	
		Z	4.35	67.44	16.43		150.0	
10432-AAA	LTE-FDD (OFDMA, 15 MHz, E-TM 3.1)	X	4.69	67.49	16.69	0.00	150.0	± 9.6 %
		Y	4.62	67.20	16.38		150.0	
		Z	4.65	67.32	16.48		150.0	
10433-AAA	LTE-FDD (OFDMA, 20 MHz, E-TM 3.1)	X	4.93	67.46	16.74	0.00	150.0	± 9.6 %
		Y	4.87	67.20	16.45		150.0	
		Z	4.89	67.31	16.55		150.0	
10434-AAA	W-CDMA (BS Test Model 1, 64 DPCH)	X	4.38	71.21	18.18	0.00	150.0	± 9.6 %
		Y	4.35	71.12	17.99		150.0	
		Z	4.34	71.07	18.01		150.0	
10435-AAB	LTE-TDD (SC-FDMA, 1 RB, 20 MHz, QPSK, UL Subframe=2,3,4,7,8,9)	X	100.00	125.05	32.43	3.23	80.0	± 9.6 %
		Y	100.00	122.57	31.34		80.0	
		Z	100.00	124.29	32.13		80.0	
10447-AAA	LTE-FDD (OFDMA, 5 MHz, E-TM 3.1, Clipping 44%)	X	3.71	67.79	16.12	0.00	150.0	± 9.6 %
		Y	3.61	67.29	15.67		150.0	
		Z	3.65	67.48	15.83		150.0	
10448-AAA	LTE-FDD (OFDMA, 10 MHz, E-TM 3.1, Clipping 44%)	X	4.22	67.42	16.51	0.00	150.0	± 9.6 %
		Y	4.15	67.08	16.17		150.0	
		Z	4.18	67.21	16.28		150.0	
10449-AAA	LTE-FDD (OFDMA, 15 MHz, E-TM 3.1, Clipping 44%)	X	4.49	67.31	16.58	0.00	150.0	± 9.6 %
		Y	4.42	67.02	16.27		150.0	
		Z	4.45	67.13	16.38		150.0	
10450-AAA	LTE-FDD (OFDMA, 20 MHz, E-TM 3.1, Clipping 44%)	X	4.67	67.22	16.59	0.00	150.0	± 9.6 %
		Y	4.62	66.95	16.30		150.0	
		Z	4.64	67.06	16.40		150.0	
10451-AAA	W-CDMA (BS Test Model 1, 64 DPCH, Clipping 44%)	X	3.63	68.08	15.83	0.00	150.0	± 9.6 %
		Y	3.51	67.49	15.33		150.0	
		Z	3.56	67.71	15.51		150.0	
10456-AAA	IEEE 802.11ac WiFi (160MHz, 64-QAM, 99pc duty cycle)	X	6.40	68.36	17.05	0.00	150.0	± 9.6 %
		Y	6.34	68.15	16.82		150.0	
		Z	6.36	68.22	16.89		150.0	
10457-AAA	UMTS-FDD (DC-HSDPA)	X	3.89	65.64	16.31	0.00	150.0	± 9.6 %
		Y	3.85	65.40	16.01		150.0	
		Z	3.87	65.50	16.11		150.0	
10458-AAA	CDMA2000 (1xEV-DO, Rev. B, 2 carriers)	X	3.46	67.50	15.35	0.00	150.0	± 9.6 %
		Y	3.34	66.87	14.80		150.0	
		Z	3.39	67.11	15.01		150.0	
10459-AAA	CDMA2000 (1xEV-DO, Rev. B, 3 carriers)	X	4.52	65.47	16.05	0.00	150.0	± 9.6 %
		Y	4.52	65.47	15.86		150.0	
		Z	4.43	65.14	15.75		150.0	

10460-AAA	UMTS-FDD (WCDMA, AMR)	X	1.17	72.68	18.90	0.00	150.0	± 9.6 %
		Y	0.92	67.87	15.98		150.0	
		Z	0.99	69.33	16.91		150.0	
10461-AAA	LTE-TDD (SC-FDMA, 1 RB, 1.4 MHz, QPSK, UL Subframe=2,3,4,7,8,9)	X	100.00	132.17	35.74	3.29	80.0	± 9.6 %
		Y	100.00	128.42	34.08		80.0	
		Z	100.00	130.59	35.07		80.0	
10462-AAA	LTE-TDD (SC-FDMA, 1 RB, 1.4 MHz, 16-QAM, UL Subframe=2,3,4,7,8,9)	X	100.00	113.31	26.72	3.23	80.0	± 9.6 %
		Y	100.00	110.59	25.58		80.0	
		Z	100.00	112.57	26.48		80.0	
10463-AAA	LTE-TDD (SC-FDMA, 1 RB, 1.4 MHz, 64-QAM, UL Subframe=2,3,4,7,8,9)	X	100.00	109.35	24.86	3.23	80.0	± 9.6 %
		Y	100.00	106.97	23.86		80.0	
		Z	100.00	108.85	24.71		80.0	
10464-AAA	LTE-TDD (SC-FDMA, 1 RB, 3 MHz, QPSK, UL Subframe=2,3,4,7,8,9)	X	100.00	130.18	34.63	3.23	80.0	± 9.6 %
		Y	100.00	126.36	32.95		80.0	
		Z	100.00	128.62	33.98		80.0	
10465-AAA	LTE-TDD (SC-FDMA, 1 RB, 3 MHz, 16-QAM, UL Subframe=2,3,4,7,8,9)	X	100.00	112.71	26.43	3.23	80.0	± 9.6 %
		Y	100.00	110.00	25.29		80.0	
		Z	100.00	111.98	26.19		80.0	
10466-AAA	LTE-TDD (SC-FDMA, 1 RB, 3 MHz, 64-QAM, UL Subframe=2,3,4,7,8,9)	X	100.00	108.78	24.59	3.23	80.0	± 9.6 %
		Y	100.00	106.43	23.61		80.0	
		Z	100.00	108.29	24.45		80.0	
10467-AAB	LTE-TDD (SC-FDMA, 1 RB, 5 MHz, QPSK, UL Subframe=2,3,4,7,8,9)	X	100.00	130.44	34.75	3.23	80.0	± 9.6 %
		Y	100.00	126.60	33.07		80.0	
		Z	100.00	128.86	34.09		80.0	
10468-AAB	LTE-TDD (SC-FDMA, 1 RB, 5 MHz, 16-QAM, UL Subframe=2,3,4,7,8,9)	X	100.00	112.91	26.52	3.23	80.0	± 9.6 %
		Y	100.00	110.19	25.38		80.0	
		Z	100.00	112.17	26.28		80.0	
10469-AAB	LTE-TDD (SC-FDMA, 1 RB, 5 MHz, 64-QAM, UL Subframe=2,3,4,7,8,9)	X	100.00	108.81	24.59	3.23	80.0	± 9.6 %
		Y	100.00	106.45	23.61		80.0	
		Z	100.00	108.32	24.46		80.0	
10470-AAB	LTE-TDD (SC-FDMA, 1 RB, 10 MHz, QPSK, UL Subframe=2,3,4,7,8,9)	X	100.00	130.49	34.76	3.23	80.0	± 9.6 %
		Y	100.00	126.64	33.07		80.0	
		Z	100.00	128.91	34.11		80.0	
10471-AAB	LTE-TDD (SC-FDMA, 1 RB, 10 MHz, 16-QAM, UL Subframe=2,3,4,7,8,9)	X	100.00	112.85	26.49	3.23	80.0	± 9.6 %
		Y	100.00	110.13	25.35		80.0	
		Z	100.00	112.12	26.25		80.0	
10472-AAB	LTE-TDD (SC-FDMA, 1 RB, 10 MHz, 64-QAM, UL Subframe=2,3,4,7,8,9)	X	100.00	108.74	24.56	3.23	80.0	± 9.6 %
		Y	100.00	106.39	23.57		80.0	
		Z	100.00	108.26	24.42		80.0	
10473-AAB	LTE-TDD (SC-FDMA, 1 RB, 15 MHz, QPSK, UL Subframe=2,3,4,7,8,9)	X	100.00	130.46	34.75	3.23	80.0	± 9.6 %
		Y	100.00	126.61	33.06		80.0	
		Z	100.00	128.88	34.09		80.0	
10474-AAB	LTE-TDD (SC-FDMA, 1 RB, 15 MHz, 16-QAM, UL Subframe=2,3,4,7,8,9)	X	100.00	112.87	26.49	3.23	80.0	± 9.6 %
		Y	100.00	110.14	25.35		80.0	
		Z	100.00	112.13	26.25		80.0	
10475-AAB	LTE-TDD (SC-FDMA, 1 RB, 15 MHz, 64-QAM, UL Subframe=2,3,4,7,8,9)	X	100.00	108.76	24.57	3.23	80.0	± 9.6 %
		Y	100.00	106.40	23.58		80.0	
		Z	100.00	108.28	24.43		80.0	

10477-AAB	LTE-TDD (SC-FDMA, 1 RB, 20 MHz, 16-QAM, UL Subframe=2,3,4,7,8,9)	X	100.00	112.67	26.40	3.23	80.0	± 9.6 %
		Y	100.00	109.96	25.26		80.0	
		Z	100.00	111.94	26.16		80.0	
10478-AAB	LTE-TDD (SC-FDMA, 1 RB, 20 MHz, 64-QAM, UL Subframe=2,3,4,7,8,9)	X	100.00	108.69	24.54	3.23	80.0	± 9.6 %
		Y	100.00	106.34	23.55		80.0	
		Z	100.00	108.21	24.40		80.0	
10479-AAA	LTE-TDD (SC-FDMA, 50% RB, 1.4 MHz, QPSK, UL Subframe=2,3,4,7,8,9)	X	40.01	113.99	32.23	3.23	80.0	± 9.6 %
		Y	25.66	104.98	29.34		80.0	
		Z	28.59	107.69	30.37		80.0	
10480-AAA	LTE-TDD (SC-FDMA, 50% RB, 1.4 MHz, 16-QAM, UL Subframe=2,3,4,7,8,9)	X	65.50	112.78	29.57	3.23	80.0	± 9.6 %
		Y	38.67	103.69	26.87		80.0	
		Z	45.46	106.90	27.97		80.0	
10481-AAA	LTE-TDD (SC-FDMA, 50% RB, 1.4 MHz, 64-QAM, UL Subframe=2,3,4,7,8,9)	X	43.66	105.54	27.32	3.23	80.0	± 9.6 %
		Y	27.51	97.77	24.89		80.0	
		Z	32.53	100.89	25.98		80.0	
10482-AAA	LTE-TDD (SC-FDMA, 50% RB, 3 MHz, QPSK, UL Subframe=2,3,4,7,8,9)	X	7.07	83.64	21.75	2.23	80.0	± 9.6 %
		Y	5.28	78.63	19.68		80.0	
		Z	5.64	80.01	20.31		80.0	
10483-AAA	LTE-TDD (SC-FDMA, 50% RB, 3 MHz, 16-QAM, UL Subframe=2,3,4,7,8,9)	X	12.44	88.49	23.12	2.23	80.0	± 9.6 %
		Y	10.70	85.40	21.78		80.0	
		Z	11.46	86.94	22.49		80.0	
10484-AAA	LTE-TDD (SC-FDMA, 50% RB, 3 MHz, 64-QAM, UL Subframe=2,3,4,7,8,9)	X	10.60	85.91	22.30	2.23	80.0	± 9.6 %
		Y	9.30	83.19	21.06		80.0	
		Z	9.88	84.56	21.72		80.0	
10485-AAB	LTE-TDD (SC-FDMA, 50% RB, 5 MHz, QPSK, UL Subframe=2,3,4,7,8,9)	X	6.73	83.37	22.54	2.23	80.0	± 9.6 %
		Y	5.38	79.13	20.71		80.0	
		Z	5.62	80.23	21.24		80.0	
10486-AAB	LTE-TDD (SC-FDMA, 50% RB, 5 MHz, 16-QAM, UL Subframe=2,3,4,7,8,9)	X	4.83	74.76	18.90	2.23	80.0	± 9.6 %
		Y	4.43	72.99	17.93		80.0	
		Z	4.49	73.45	18.22		80.0	
10487-AAB	LTE-TDD (SC-FDMA, 50% RB, 5 MHz, 64-QAM, UL Subframe=2,3,4,7,8,9)	X	4.73	74.06	18.61	2.23	80.0	± 9.6 %
		Y	4.38	72.45	17.70		80.0	
		Z	4.42	72.86	17.97		80.0	
10488-AAB	LTE-TDD (SC-FDMA, 50% RB, 10 MHz, QPSK, UL Subframe=2,3,4,7,8,9)	X	5.94	79.74	21.83	2.23	80.0	± 9.6 %
		Y	5.18	76.93	20.48		80.0	
		Z	5.31	77.65	20.88		80.0	
10489-AAB	LTE-TDD (SC-FDMA, 50% RB, 10 MHz, 16-QAM, UL Subframe=2,3,4,7,8,9)	X	4.65	72.93	19.25	2.23	80.0	± 9.6 %
		Y	4.44	71.79	18.53		80.0	
		Z	4.45	72.03	18.73		80.0	
10490-AAB	LTE-TDD (SC-FDMA, 50% RB, 10 MHz, 64-QAM, UL Subframe=2,3,4,7,8,9)	X	4.70	72.53	19.10	2.23	80.0	± 9.6 %
		Y	4.51	71.49	18.42		80.0	
		Z	4.51	71.71	18.61		80.0	
10491-AAB	LTE-TDD (SC-FDMA, 50% RB, 15 MHz, QPSK, UL Subframe=2,3,4,7,8,9)	X	5.47	76.11	20.55	2.23	80.0	± 9.6 %
		Y	5.05	74.35	19.60		80.0	
		Z	5.11	74.80	19.88		80.0	
10492-AAB	LTE-TDD (SC-FDMA, 50% RB, 15 MHz, 16-QAM, UL Subframe=2,3,4,7,8,9)	X	4.82	71.43	18.89	2.23	80.0	± 9.6 %
		Y	4.68	70.61	18.31		80.0	
		Z	4.67	70.78	18.47		80.0	

10493-AAB	LTE-TDD (SC-FDMA, 50% RB, 15 MHz, 64-QAM, UL Subframe=2,3,4,7,8,9)	X	4.87	71.19	18.80	2.23	80.0	± 9.6 %
		Y	4.73	70.41	18.24		80.0	
		Z	4.72	70.57	18.39		80.0	
10494-AAB	LTE-TDD (SC-FDMA, 50% RB, 20 MHz, QPSK, UL Subframe=2,3,4,7,8,9)	X	6.24	78.41	21.24	2.23	80.0	± 9.6 %
		Y	5.62	76.22	20.16		80.0	
		Z	5.73	76.81	20.48		80.0	
10495-AAB	LTE-TDD (SC-FDMA, 50% RB, 20 MHz, 16-QAM, UL Subframe=2,3,4,7,8,9)	X	4.91	72.01	19.14	2.23	80.0	± 9.6 %
		Y	4.75	71.11	18.53		80.0	
		Z	4.74	71.30	18.69		80.0	
10496-AAB	LTE-TDD (SC-FDMA, 50% RB, 20 MHz, 64-QAM, UL Subframe=2,3,4,7,8,9)	X	4.93	71.51	18.96	2.23	80.0	± 9.6 %
		Y	4.79	70.71	18.40		80.0	
		Z	4.78	70.87	18.55		80.0	
10497-AAA	LTE-TDD (SC-FDMA, 100% RB, 1.4 MHz, QPSK, UL Subframe=2,3,4,7,8,9)	X	5.37	79.10	19.27	2.23	80.0	± 9.6 %
		Y	4.01	74.46	17.26		80.0	
		Z	4.32	75.84	17.92		80.0	
10498-AAA	LTE-TDD (SC-FDMA, 100% RB, 1.4 MHz, 16-QAM, UL Subframe=2,3,4,7,8,9)	X	3.20	69.04	14.31	2.23	80.0	± 9.6 %
		Y	2.73	66.72	13.06		80.0	
		Z	2.85	67.49	13.50		80.0	
10499-AAA	LTE-TDD (SC-FDMA, 100% RB, 1.4 MHz, 64-QAM, UL Subframe=2,3,4,7,8,9)	X	3.04	68.09	13.76	2.23	80.0	± 9.6 %
		Y	2.62	65.95	12.57		80.0	
		Z	2.73	66.66	12.99		80.0	
10500-AAA	LTE-TDD (SC-FDMA, 100% RB, 3 MHz, QPSK, UL Subframe=2,3,4,7,8,9)	X	6.09	81.07	21.99	2.23	80.0	± 9.6 %
		Y	5.13	77.67	20.43		80.0	
		Z	5.29	78.55	20.89		80.0	
10501-AAA	LTE-TDD (SC-FDMA, 100% RB, 3 MHz, 16-QAM, UL Subframe=2,3,4,7,8,9)	X	4.73	73.89	18.97	2.23	80.0	± 9.6 %
		Y	4.43	72.44	18.13		80.0	
		Z	4.46	72.79	18.37		80.0	
10502-AAA	LTE-TDD (SC-FDMA, 100% RB, 3 MHz, 64-QAM, UL Subframe=2,3,4,7,8,9)	X	4.76	73.56	18.78	2.23	80.0	± 9.6 %
		Y	4.47	72.19	17.97		80.0	
		Z	4.49	72.52	18.21		80.0	
10503-AAB	LTE-TDD (SC-FDMA, 100% RB, 5 MHz, QPSK, UL Subframe=2,3,4,7,8,9)	X	5.85	79.51	21.73	2.23	80.0	± 9.6 %
		Y	5.11	76.71	20.38		80.0	
		Z	5.24	77.44	20.78		80.0	
10504-AAB	LTE-TDD (SC-FDMA, 100% RB, 5 MHz, 16-QAM, UL Subframe=2,3,4,7,8,9)	X	4.63	72.85	19.20	2.23	80.0	± 9.6 %
		Y	4.42	71.70	18.48		80.0	
		Z	4.43	71.95	18.68		80.0	
10505-AAB	LTE-TDD (SC-FDMA, 100% RB, 5 MHz, 64-QAM, UL Subframe=2,3,4,7,8,9)	X	4.68	72.44	19.05	2.23	80.0	± 9.6 %
		Y	4.49	71.39	18.37		80.0	
		Z	4.49	71.62	18.56		80.0	
10506-AAB	LTE-TDD (SC-FDMA, 100% RB, 10 MHz, QPSK, UL Subframe=2,3,4,7,8,9)	X	6.19	78.25	21.17	2.23	80.0	± 9.6 %
		Y	5.58	76.07	20.08		80.0	
		Z	5.68	76.66	20.41		80.0	
10507-AAB	LTE-TDD (SC-FDMA, 100% RB, 10 MHz, 16-QAM, UL Subframe=2,3,4,7,8,9)	X	4.89	71.95	19.11	2.23	80.0	± 9.6 %
		Y	4.73	71.04	18.50		80.0	
		Z	4.73	71.24	18.66		80.0	

10508-AAB	LTE-TDD (SC-FDMA, 100% RB, 10 MHz, 64-QAM, UL Subframe=2,3,4,7,8,9)	X	4.92	71.45	18.93	2.23	80.0	± 9.6 %
		Y	4.78	70.64	18.36		80.0	
		Z	4.77	70.80	18.51		80.0	
10509-AAB	LTE-TDD (SC-FDMA, 100% RB, 15 MHz, QPSK, UL Subframe=2,3,4,7,8,9)	X	5.95	75.24	19.99	2.23	80.0	± 9.6 %
		Y	5.60	73.90	19.24		80.0	
		Z	5.65	74.26	19.47		80.0	
10510-AAB	LTE-TDD (SC-FDMA, 100% RB, 15 MHz, 16-QAM, UL Subframe=2,3,4,7,8,9)	X	5.29	71.15	18.83	2.23	80.0	± 9.6 %
		Y	5.16	70.46	18.33		80.0	
		Z	5.15	70.61	18.47		80.0	
10511-AAB	LTE-TDD (SC-FDMA, 100% RB, 15 MHz, 64-QAM, UL Subframe=2,3,4,7,8,9)	X	5.30	70.75	18.70	2.23	80.0	± 9.6 %
		Y	5.19	70.12	18.23		80.0	
		Z	5.17	70.25	18.36		80.0	
10512-AAB	LTE-TDD (SC-FDMA, 100% RB, 20 MHz, QPSK, UL Subframe=2,3,4,7,8,9)	X	6.65	77.81	20.82	2.23	80.0	± 9.6 %
		Y	6.08	75.94	19.88		80.0	
		Z	6.18	76.48	20.17		80.0	
10513-AAB	LTE-TDD (SC-FDMA, 100% RB, 20 MHz, 16-QAM, UL Subframe=2,3,4,7,8,9)	X	5.24	71.68	19.04	2.23	80.0	± 9.6 %
		Y	5.09	70.89	18.50		80.0	
		Z	5.08	71.06	18.65		80.0	
10514-AAB	LTE-TDD (SC-FDMA, 100% RB, 20 MHz, 64-QAM, UL Subframe=2,3,4,7,8,9)	X	5.18	71.04	18.83	2.23	80.0	± 9.6 %
		Y	5.06	70.34	18.33		80.0	
		Z	5.05	70.49	18.47		80.0	
10515-AAA	IEEE 802.11b WiFi 2.4 GHz (DSSS, 2 Mbps, 99pc duty cycle)	X	1.04	64.30	15.79	0.00	150.0	± 9.6 %
		Y	1.00	63.17	14.68		150.0	
		Z	1.01	63.58	15.06		150.0	
10516-AAA	IEEE 802.11b WiFi 2.4 GHz (DSSS, 5.5 Mbps, 99pc duty cycle)	X	1.17	82.68	23.48	0.00	150.0	± 9.6 %
		Y	0.61	69.65	16.88		150.0	
		Z	0.72	72.79	18.69		150.0	
10517-AAA	IEEE 802.11b WiFi 2.4 GHz (DSSS, 11 Mbps, 99pc duty cycle)	X	0.94	67.44	17.14	0.00	150.0	± 9.6 %
		Y	0.85	65.01	15.25		150.0	
		Z	0.88	65.81	15.88		150.0	
10518-AAA	IEEE 802.11a/h WiFi 5 GHz (OFDM, 9 Mbps, 99pc duty cycle)	X	4.68	67.10	16.57	0.00	150.0	± 9.6 %
		Y	4.62	66.85	16.28		150.0	
		Z	4.64	66.95	16.38		150.0	
10519-AAA	IEEE 802.11a/h WiFi 5 GHz (OFDM, 12 Mbps, 99pc duty cycle)	X	4.88	67.37	16.70	0.00	150.0	± 9.6 %
		Y	4.82	67.11	16.42		150.0	
		Z	4.84	67.21	16.51		150.0	
10520-AAA	IEEE 802.11a/h WiFi 5 GHz (OFDM, 18 Mbps, 99pc duty cycle)	X	4.73	67.35	16.63	0.00	150.0	± 9.6 %
		Y	4.67	67.07	16.33		150.0	
		Z	4.69	67.18	16.43		150.0	
10521-AAA	IEEE 802.11a/h WiFi 5 GHz (OFDM, 24 Mbps, 99pc duty cycle)	X	4.66	67.35	16.62	0.00	150.0	± 9.6 %
		Y	4.60	67.06	16.32		150.0	
		Z	4.62	67.17	16.42		150.0	
10522-AAA	IEEE 802.11a/h WiFi 5 GHz (OFDM, 36 Mbps, 99pc duty cycle)	X	4.72	67.40	16.69	0.00	150.0	± 9.6 %
		Y	4.66	67.13	16.39		150.0	
		Z	4.68	67.24	16.49		150.0	

10523-AAA	IEEE 802.11a/h WiFi 5 GHz (OFDM, 48 Mbps, 99pc duty cycle)	X	4.59	67.26	16.53	0.00	150.0	± 9.6 %
		Y	4.53	66.98	16.23		150.0	
		Z	4.55	67.09	16.33		150.0	
10524-AAA	IEEE 802.11a/h WiFi 5 GHz (OFDM, 54 Mbps, 99pc duty cycle)	X	4.66	67.34	16.66	0.00	150.0	± 9.6 %
		Y	4.60	67.06	16.36		150.0	
		Z	4.63	67.17	16.46		150.0	
10525-AAA	IEEE 802.11ac WiFi (20MHz, MCS0, 99pc duty cycle)	X	4.64	66.35	16.23	0.00	150.0	± 9.6 %
		Y	4.58	66.08	15.94		150.0	
		Z	4.60	66.19	16.04		150.0	
10526-AAA	IEEE 802.11ac WiFi (20MHz, MCS1, 99pc duty cycle)	X	4.82	66.75	16.38	0.00	150.0	± 9.6 %
		Y	4.76	66.47	16.09		150.0	
		Z	4.78	66.58	16.19		150.0	
10527-AAA	IEEE 802.11ac WiFi (20MHz, MCS2, 99pc duty cycle)	X	4.74	66.71	16.33	0.00	150.0	± 9.6 %
		Y	4.68	66.42	16.03		150.0	
		Z	4.70	66.54	16.13		150.0	
10528-AAA	IEEE 802.11ac WiFi (20MHz, MCS3, 99pc duty cycle)	X	4.76	66.73	16.36	0.00	150.0	± 9.6 %
		Y	4.69	66.44	16.07		150.0	
		Z	4.72	66.56	16.17		150.0	
10529-AAA	IEEE 802.11ac WiFi (20MHz, MCS4, 99pc duty cycle)	X	4.76	66.73	16.36	0.00	150.0	± 9.6 %
		Y	4.69	66.44	16.07		150.0	
		Z	4.72	66.56	16.17		150.0	
10531-AAA	IEEE 802.11ac WiFi (20MHz, MCS6, 99pc duty cycle)	X	4.76	66.87	16.39	0.00	150.0	± 9.6 %
		Y	4.69	66.56	16.08		150.0	
		Z	4.72	66.68	16.19		150.0	
10532-AAA	IEEE 802.11ac WiFi (20MHz, MCS7, 99pc duty cycle)	X	4.62	66.72	16.33	0.00	150.0	± 9.6 %
		Y	4.55	66.41	16.02		150.0	
		Z	4.57	66.53	16.12		150.0	
10533-AAA	IEEE 802.11ac WiFi (20MHz, MCS8, 99pc duty cycle)	X	4.77	66.77	16.35	0.00	150.0	± 9.6 %
		Y	4.70	66.48	16.05		150.0	
		Z	4.73	66.80	16.15		150.0	
10534-AAA	IEEE 802.11ac WiFi (40MHz, MCS0, 99pc duty cycle)	X	5.29	66.84	16.41	0.00	150.0	± 9.6 %
		Y	5.23	66.60	16.14		150.0	
		Z	5.25	66.69	16.23		150.0	
10535-AAA	IEEE 802.11ac WiFi (40MHz, MCS1, 99pc duty cycle)	X	5.37	67.02	16.49	0.00	150.0	± 9.6 %
		Y	5.30	66.78	16.22		150.0	
		Z	5.32	66.87	16.31		150.0	
10536-AAA	IEEE 802.11ac WiFi (40MHz, MCS2, 99pc duty cycle)	X	5.23	66.97	16.44	0.00	150.0	± 9.6 %
		Y	5.17	66.72	16.17		150.0	
		Z	5.19	66.82	16.26		150.0	
10537-AAA	IEEE 802.11ac WiFi (40MHz, MCS3, 99pc duty cycle)	X	5.29	66.95	16.43	0.00	150.0	± 9.6 %
		Y	5.23	66.69	16.17		150.0	
		Z	5.25	66.79	16.25		150.0	
10538-AAA	IEEE 802.11ac WiFi (40MHz, MCS4, 99pc duty cycle)	X	5.39	66.99	16.50	0.00	150.0	± 9.6 %
		Y	5.33	66.74	16.23		150.0	
		Z	5.35	66.84	16.31		150.0	
10540-AAA	IEEE 802.11ac WiFi (40MHz, MCS6, 99pc duty cycle)	X	5.32	66.99	16.51	0.00	150.0	± 9.6 %
		Y	5.25	66.74	16.24		150.0	
		Z	5.27	66.83	16.33		150.0	

10541-AAA	IEEE 802.11ac WiFi (40MHz, MCS7, 99pc duty cycle)	X	5.28	66.83	16.43	0.00	150.0	± 9.6 %
		Y	5.22	66.59	16.16		150.0	
		Z	5.24	66.69	16.25		150.0	
10542-AAA	IEEE 802.11ac WiFi (40MHz, MCS8, 99pc duty cycle)	X	5.44	66.91	16.48	0.00	150.0	± 9.6 %
		Y	5.38	66.68	16.22		150.0	
		Z	5.40	66.77	16.30		150.0	
10543-AAA	IEEE 802.11ac WiFi (40MHz, MCS9, 99pc duty cycle)	X	5.53	66.97	16.53	0.00	150.0	± 9.6 %
		Y	5.47	66.73	16.27		150.0	
		Z	5.49	66.82	16.35		150.0	
10544-AAA	IEEE 802.11ac WiFi (80MHz, MCS0, 99pc duty cycle)	X	5.59	66.91	16.37	0.00	150.0	± 9.6 %
		Y	5.53	66.70	16.13		150.0	
		Z	5.55	66.79	16.21		150.0	
10545-AAA	IEEE 802.11ac WiFi (80MHz, MCS1, 99pc duty cycle)	X	5.82	67.42	16.57	0.00	150.0	± 9.6 %
		Y	5.75	67.17	16.32		150.0	
		Z	5.77	67.26	16.40		150.0	
10546-AAA	IEEE 802.11ac WiFi (80MHz, MCS2, 99pc duty cycle)	X	5.68	67.19	16.48	0.00	150.0	± 9.6 %
		Y	5.61	66.95	16.22		150.0	
		Z	5.64	67.05	16.30		150.0	
10547-AAA	IEEE 802.11ac WiFi (80MHz, MCS3, 99pc duty cycle)	X	5.77	67.28	16.51	0.00	150.0	± 9.6 %
		Y	5.70	67.03	16.25		150.0	
		Z	5.72	67.12	16.33		150.0	
10548-AAA	IEEE 802.11ac WiFi (80MHz, MCS4, 99pc duty cycle)	X	6.16	68.66	17.18	0.00	150.0	± 9.6 %
		Y	6.05	68.25	16.83		150.0	
		Z	6.07	68.36	16.93		150.0	
10550-AAA	IEEE 802.11ac WiFi (80MHz, MCS6, 99pc duty cycle)	X	5.70	67.18	16.48	0.00	150.0	± 9.6 %
		Y	5.64	66.95	16.23		150.0	
		Z	5.66	67.04	16.31		150.0	
10551-AAA	IEEE 802.11ac WiFi (80MHz, MCS7, 99pc duty cycle)	X	5.70	67.20	16.45	0.00	150.0	± 9.6 %
		Y	5.64	66.98	16.21		150.0	
		Z	5.66	67.07	16.28		150.0	
10552-AAA	IEEE 802.11ac WiFi (80MHz, MCS8, 99pc duty cycle)	X	5.60	66.97	16.34	0.00	150.0	± 9.6 %
		Y	5.55	66.76	16.11		150.0	
		Z	5.57	66.85	16.18		150.0	
10553-AAA	IEEE 802.11ac WiFi (80MHz, MCS9, 99pc duty cycle)	X	5.69	67.02	16.40	0.00	150.0	± 9.6 %
		Y	5.64	66.81	16.16		150.0	
		Z	5.66	66.90	16.24		150.0	
10554-AAA	IEEE 1602.11ac WiFi (160MHz, MCS0, 99pc duty cycle)	X	6.00	67.29	16.47	0.00	150.0	± 9.6 %
		Y	5.95	67.09	16.23		150.0	
		Z	5.96	67.17	16.31		150.0	
10555-AAA	IEEE 1602.11ac WiFi (160MHz, MCS1, 99pc duty cycle)	X	6.15	67.65	16.62	0.00	150.0	± 9.6 %
		Y	6.09	67.42	16.38		150.0	
		Z	6.11	67.51	16.45		150.0	
10556-AAA	IEEE 1602.11ac WiFi (160MHz, MCS2, 99pc duty cycle)	X	6.17	67.68	16.63	0.00	150.0	± 9.6 %
		Y	6.11	67.45	16.39		150.0	
		Z	6.13	67.54	16.46		150.0	
10557-AAA	IEEE 1602.11ac WiFi (160MHz, MCS3, 99pc duty cycle)	X	6.14	67.59	16.60	0.00	150.0	± 9.6 %
		Y	6.07	67.36	16.36		150.0	
		Z	6.09	67.45	16.44		150.0	

10558-AAA	IEEE 1602.11ac WiFi (160MHz, MCS4, 99pc duty cycle)	X	6.20	67.79	16.72	0.00	150.0	± 9.6 %
		Y	6.13	67.55	16.47		150.0	
		Z	6.15	67.64	16.55		150.0	
10560-AAA	IEEE 1602.11ac WiFi (160MHz, MCS6, 99pc duty cycle)	X	6.18	67.59	16.66	0.00	150.0	± 9.6 %
		Y	6.11	67.37	16.42		150.0	
		Z	6.14	67.46	16.49		150.0	
10561-AAA	IEEE 1602.11ac WiFi (160MHz, MCS7, 99pc duty cycle)	X	6.10	67.58	16.69	0.00	150.0	± 9.6 %
		Y	6.04	67.35	16.45		150.0	
		Z	6.06	67.44	16.52		150.0	
10562-AAA	IEEE 1602.11ac WiFi (160MHz, MCS8, 99pc duty cycle)	X	6.27	68.10	16.96	0.00	150.0	± 9.6 %
		Y	6.19	67.81	16.68		150.0	
		Z	6.21	67.92	16.77		150.0	
10563-AAA	IEEE 1602.11ac WiFi (160MHz, MCS9, 99pc duty cycle)	X	6.68	68.88	17.30	0.00	150.0	± 9.6 %
		Y	6.56	68.48	16.97		150.0	
		Z	6.59	68.61	17.07		150.0	
10564-AAA	IEEE 802.11g WiFi 2.4 GHz (DSSS-OFDM, 9 Mbps, 99pc duty cycle)	X	5.02	67.23	16.76	0.46	150.0	± 9.6 %
		Y	4.96	66.98	16.48		150.0	
		Z	4.98	67.08	16.57		150.0	
10565-AAA	IEEE 802.11g WiFi 2.4 GHz (DSSS-OFDM, 12 Mbps, 99pc duty cycle)	X	5.26	67.67	17.06	0.46	150.0	± 9.6 %
		Y	5.20	67.43	16.79		150.0	
		Z	5.22	67.52	16.88		150.0	
10566-AAA	IEEE 802.11g WiFi 2.4 GHz (DSSS-OFDM, 18 Mbps, 99pc duty cycle)	X	5.09	67.55	16.90	0.46	150.0	± 9.6 %
		Y	5.03	67.29	16.62		150.0	
		Z	5.05	67.39	16.71		150.0	
10567-AAA	IEEE 802.11g WiFi 2.4 GHz (DSSS-OFDM, 24 Mbps, 99pc duty cycle)	X	5.11	67.86	17.20	0.46	150.0	± 9.6 %
		Y	5.05	67.64	16.94		150.0	
		Z	5.07	67.72	17.02		150.0	
10568-AAA	IEEE 802.11g WiFi 2.4 GHz (DSSS-OFDM, 36 Mbps, 99pc duty cycle)	X	5.02	67.38	16.73	0.46	150.0	± 9.6 %
		Y	4.95	67.09	16.41		150.0	
		Z	4.98	67.21	16.52		150.0	
10569-AAA	IEEE 802.11g WiFi 2.4 GHz (DSSS-OFDM, 48 Mbps, 99pc duty cycle)	X	5.05	67.90	17.23	0.46	150.0	± 9.6 %
		Y	5.00	67.70	16.99		150.0	
		Z	5.02	67.78	17.06		150.0	
10570-AAA	IEEE 802.11g WiFi 2.4 GHz (DSSS-OFDM, 54 Mbps, 99pc duty cycle)	X	5.10	67.80	17.20	0.46	150.0	± 9.6 %
		Y	5.05	67.57	16.93		150.0	
		Z	5.07	67.66	17.02		150.0	
10571-AAA	IEEE 802.11b WiFi 2.4 GHz (DSSS, 1 Mbps, 90pc duty cycle)	X	1.35	66.69	17.17	0.46	130.0	± 9.6 %
		Y	1.30	65.45	16.06		130.0	
		Z	1.31	65.81	16.41		130.0	
10572-AAA	IEEE 802.11b WiFi 2.4 GHz (DSSS, 2 Mbps, 90pc duty cycle)	X	1.38	67.41	17.59	0.46	130.0	± 9.6 %
		Y	1.32	66.05	16.42		130.0	
		Z	1.33	66.44	16.78		130.0	
10573-AAA	IEEE 802.11b WiFi 2.4 GHz (DSSS, 5.5 Mbps, 90pc duty cycle)	X	100.00	151.66	41.18	0.46	130.0	± 9.6 %
		Y	3.17	90.18	24.53		130.0	
		Z	5.56	100.47	28.08		130.0	
10574-AAA	IEEE 802.11b WiFi 2.4 GHz (DSSS, 11 Mbps, 90pc duty cycle)	X	1.74	75.66	21.49	0.46	130.0	± 9.6 %
		Y	1.50	72.10	19.33		130.0	
		Z	1.55	73.02	19.95		130.0	

10575-AAA	IEEE 802.11g WiFi 2.4 GHz (DSSS-OFDM, 6 Mbps, 90pc duty cycle)	X	4.81	67.07	16.85	0.46	130.0	± 9.6 %
		Y	4.77	66.83	16.57		130.0	
		Z	4.78	66.92	16.66		130.0	
10576-AAA	IEEE 802.11g WiFi 2.4 GHz (DSSS-OFDM, 9 Mbps, 90pc duty cycle)	X	4.84	67.21	16.90	0.46	130.0	± 9.6 %
		Y	4.79	66.98	16.63		130.0	
		Z	4.81	67.07	16.71		130.0	
10577-AAA	IEEE 802.11g WiFi 2.4 GHz (DSSS-OFDM, 12 Mbps, 90pc duty cycle)	X	5.05	67.51	17.07	0.46	130.0	± 9.6 %
		Y	5.00	67.28	16.80		130.0	
		Z	5.02	67.37	16.88		130.0	
10578-AAA	IEEE 802.11g WiFi 2.4 GHz (DSSS-OFDM, 18 Mbps, 90pc duty cycle)	X	4.95	67.65	17.15	0.46	130.0	± 9.6 %
		Y	4.90	67.43	16.89		130.0	
		Z	4.91	67.51	16.97		130.0	
10579-AAA	IEEE 802.11g WiFi 2.4 GHz (DSSS-OFDM, 24 Mbps, 90pc duty cycle)	X	4.73	67.10	16.58	0.46	130.0	± 9.6 %
		Y	4.67	66.80	16.26		130.0	
		Z	4.70	66.92	16.37		130.0	
10580-AAA	IEEE 802.11g WiFi 2.4 GHz (DSSS-OFDM, 36 Mbps, 90pc duty cycle)	X	4.79	67.13	16.61	0.46	130.0	± 9.6 %
		Y	4.72	66.82	16.27		130.0	
		Z	4.74	66.95	16.39		130.0	
10581-AAA	IEEE 802.11g WiFi 2.4 GHz (DSSS-OFDM, 48 Mbps, 90pc duty cycle)	X	4.85	67.72	17.11	0.46	130.0	± 9.6 %
		Y	4.80	67.49	16.84		130.0	
		Z	4.81	67.57	16.92		130.0	
10582-AAA	IEEE 802.11g WiFi 2.4 GHz (DSSS-OFDM, 54 Mbps, 90pc duty cycle)	X	4.69	66.92	16.42	0.46	130.0	± 9.6 %
		Y	4.62	66.58	16.06		130.0	
		Z	4.65	66.72	16.19		130.0	
10583-AAA	IEEE 802.11a/h WiFi 5 GHz (OFDM, 6 Mbps, 90pc duty cycle)	X	4.81	67.07	16.85	0.46	130.0	± 9.6 %
		Y	4.77	66.83	16.57		130.0	
		Z	4.78	66.92	16.66		130.0	
10584-AAA	IEEE 802.11a/h WiFi 5 GHz (OFDM, 9 Mbps, 90pc duty cycle)	X	4.84	67.21	16.90	0.46	130.0	± 9.6 %
		Y	4.79	66.98	16.63		130.0	
		Z	4.81	67.07	16.71		130.0	
10585-AAA	IEEE 802.11a/h WiFi 5 GHz (OFDM, 12 Mbps, 90pc duty cycle)	X	5.05	67.51	17.07	0.46	130.0	± 9.6 %
		Y	5.00	67.28	16.80		130.0	
		Z	5.02	67.37	16.88		130.0	
10586-AAA	IEEE 802.11a/h WiFi 5 GHz (OFDM, 18 Mbps, 90pc duty cycle)	X	4.95	67.65	17.15	0.46	130.0	± 9.6 %
		Y	4.90	67.43	16.89		130.0	
		Z	4.91	67.51	16.97		130.0	
10587-AAA	IEEE 802.11a/h WiFi 5 GHz (OFDM, 24 Mbps, 90pc duty cycle)	X	4.73	67.10	16.58	0.46	130.0	± 9.6 %
		Y	4.67	66.80	16.26		130.0	
		Z	4.70	66.92	16.37		130.0	
10588-AAA	IEEE 802.11a/h WiFi 5 GHz (OFDM, 36 Mbps, 90pc duty cycle)	X	4.79	67.13	16.61	0.46	130.0	± 9.6 %
		Y	4.72	66.82	16.27		130.0	
		Z	4.74	66.95	16.39		130.0	
10589-AAA	IEEE 802.11a/h WiFi 5 GHz (OFDM, 48 Mbps, 90pc duty cycle)	X	4.85	67.72	17.11	0.46	130.0	± 9.6 %
		Y	4.80	67.49	16.84		130.0	
		Z	4.81	67.57	16.92		130.0	
10590-AAA	IEEE 802.11a/h WiFi 5 GHz (OFDM, 54 Mbps, 90pc duty cycle)	X	4.69	66.92	16.42	0.46	130.0	± 9.6 %
		Y	4.62	66.58	16.06		130.0	
		Z	4.65	66.72	16.19		130.0	

10591-AAA	IEEE 802.11n (HT Mixed, 20MHz, MCS0, 90pc duty cycle)	X	4.96	67.09	16.93	0.46	130.0	± 9.6 %
		Y	4.92	66.88	16.66		130.0	
		Z	4.93	66.96	16.75		130.0	
10592-AAA	IEEE 802.11n (HT Mixed, 20MHz, MCS1, 90pc duty cycle)	X	5.13	67.44	17.05	0.46	130.0	± 9.6 %
		Y	5.08	67.22	16.79		130.0	
		Z	5.09	67.30	16.87		130.0	
10593-AAA	IEEE 802.11n (HT Mixed, 20MHz, MCS2, 90pc duty cycle)	X	5.05	67.38	16.96	0.46	130.0	± 9.6 %
		Y	5.00	67.15	16.69		130.0	
		Z	5.02	67.24	16.77		130.0	
10594-AAA	IEEE 802.11n (HT Mixed, 20MHz, MCS3, 90pc duty cycle)	X	5.10	67.52	17.09	0.46	130.0	± 9.6 %
		Y	5.05	67.30	16.83		130.0	
		Z	5.07	67.38	16.91		130.0	
10595-AAA	IEEE 802.11n (HT Mixed, 20MHz, MCS4, 90pc duty cycle)	X	5.08	67.50	17.01	0.46	130.0	± 9.6 %
		Y	5.02	67.26	16.73		130.0	
		Z	5.04	67.35	16.82		130.0	
10596-AAA	IEEE 802.11n (HT Mixed, 20MHz, MCS5, 90pc duty cycle)	X	5.02	67.52	17.02	0.46	130.0	± 9.6 %
		Y	4.96	67.27	16.74		130.0	
		Z	4.98	67.36	16.83		130.0	
10597-AAA	IEEE 802.11n (HT Mixed, 20MHz, MCS6, 90pc duty cycle)	X	4.97	67.44	16.92	0.46	130.0	± 9.6 %
		Y	4.91	67.18	16.63		130.0	
		Z	4.93	67.28	16.72		130.0	
10598-AAA	IEEE 802.11n (HT Mixed, 20MHz, MCS7, 90pc duty cycle)	X	4.94	67.63	17.14	0.46	130.0	± 9.6 %
		Y	4.89	67.40	16.88		130.0	
		Z	4.91	67.48	16.96		130.0	
10599-AAA	IEEE 802.11n (HT Mixed, 40MHz, MCS0, 90pc duty cycle)	X	5.64	67.68	17.14	0.46	130.0	± 9.6 %
		Y	5.59	67.47	16.88		130.0	
		Z	5.61	67.54	16.96		130.0	
10600-AAA	IEEE 802.11n (HT Mixed, 40MHz, MCS1, 90pc duty cycle)	X	5.87	68.41	17.49	0.46	130.0	± 9.6 %
		Y	5.79	68.09	17.17		130.0	
		Z	5.81	68.18	17.26		130.0	
10601-AAA	IEEE 802.11n (HT Mixed, 40MHz, MCS2, 90pc duty cycle)	X	5.71	67.98	17.28	0.46	130.0	± 9.6 %
		Y	5.65	67.72	17.00		130.0	
		Z	5.66	67.81	17.08		130.0	
10602-AAA	IEEE 802.11n (HT Mixed, 40MHz, MCS3, 90pc duty cycle)	X	5.79	67.98	17.21	0.46	130.0	± 9.6 %
		Y	5.73	67.73	16.93		130.0	
		Z	5.75	67.82	17.01		130.0	
10603-AAA	IEEE 802.11n (HT Mixed, 40MHz, MCS4, 90pc duty cycle)	X	5.87	68.25	17.46	0.46	130.0	± 9.6 %
		Y	5.81	68.01	17.19		130.0	
		Z	5.83	68.09	17.27		130.0	
10604-AAA	IEEE 802.11n (HT Mixed, 40MHz, MCS5, 90pc duty cycle)	X	5.65	67.64	17.14	0.46	130.0	± 9.6 %
		Y	5.60	67.42	16.89		130.0	
		Z	5.61	67.50	16.96		130.0	
10605-AAA	IEEE 802.11n (HT Mixed, 40MHz, MCS6, 90pc duty cycle)	X	5.80	68.11	17.39	0.46	130.0	± 9.6 %
		Y	5.73	67.85	17.10		130.0	
		Z	5.75	67.93	17.19		130.0	
10606-AAA	IEEE 802.11n (HT Mixed, 40MHz, MCS7, 90pc duty cycle)	X	5.53	67.43	16.92	0.46	130.0	± 9.6 %
		Y	5.48	67.20	16.64		130.0	
		Z	5.50	67.29	16.73		130.0	

10607-AAA	IEEE 802.11ac WiFi (20MHz, MCS0, 90pc duty cycle)	X	4.80	66.40	16.54	0.46	130.0	± 9.6 %
		Y	4.75	66.17	16.27		130.0	
		Z	4.76	66.26	16.35		130.0	
10608-AAA	IEEE 802.11ac WiFi (20MHz, MCS1, 90pc duty cycle)	X	5.00	66.83	16.71	0.46	130.0	± 9.6 %
		Y	4.94	66.59	16.44		130.0	
		Z	4.96	66.68	16.52		130.0	
10609-AAA	IEEE 802.11ac WiFi (20MHz, MCS2, 90pc duty cycle)	X	4.89	66.71	16.57	0.46	130.0	± 9.6 %
		Y	4.83	66.45	16.28		130.0	
		Z	4.85	66.55	16.38		130.0	
10610-AAA	IEEE 802.11ac WiFi (20MHz, MCS3, 90pc duty cycle)	X	4.94	66.85	16.71	0.46	130.0	± 9.6 %
		Y	4.88	66.60	16.44		130.0	
		Z	4.90	66.69	16.53		130.0	
10611-AAA	IEEE 802.11ac WiFi (20MHz, MCS4, 90pc duty cycle)	X	4.86	66.68	16.58	0.46	130.0	± 9.6 %
		Y	4.80	66.42	16.30		130.0	
		Z	4.82	66.52	16.39		130.0	
10612-AAA	IEEE 802.11ac WiFi (20MHz, MCS5, 90pc duty cycle)	X	4.88	66.87	16.65	0.46	130.0	± 9.6 %
		Y	4.82	66.59	16.35		130.0	
		Z	4.84	66.69	16.44		130.0	
10613-AAA	IEEE 802.11ac WiFi (20MHz, MCS6, 90pc duty cycle)	X	4.89	66.78	16.55	0.46	130.0	± 9.6 %
		Y	4.82	66.49	16.24		130.0	
		Z	4.85	66.60	16.34		130.0	
10614-AAA	IEEE 802.11ac WiFi (20MHz, MCS7, 90pc duty cycle)	X	4.81	66.89	16.73	0.46	130.0	± 9.6 %
		Y	4.75	66.64	16.45		130.0	
		Z	4.77	66.73	16.54		130.0	
10615-AAA	IEEE 802.11ac WiFi (20MHz, MCS8, 90pc duty cycle)	X	4.87	66.56	16.40	0.46	130.0	± 9.6 %
		Y	4.81	66.27	16.09		130.0	
		Z	4.83	66.38	16.19		130.0	
10616-AAA	IEEE 802.11ac WiFi (40MHz, MCS0, 90pc duty cycle)	X	5.46	66.92	16.73	0.46	130.0	± 9.6 %
		Y	5.41	66.70	16.48		130.0	
		Z	5.43	66.79	16.56		130.0	
10617-AAA	IEEE 802.11ac WiFi (40MHz, MCS1, 90pc duty cycle)	X	5.54	67.11	16.80	0.46	130.0	± 9.6 %
		Y	5.48	66.88	16.54		130.0	
		Z	5.50	66.96	16.62		130.0	
10618-AAA	IEEE 802.11ac WiFi (40MHz, MCS2, 90pc duty cycle)	X	5.42	67.11	16.81	0.46	130.0	± 9.6 %
		Y	5.36	66.88	16.56		130.0	
		Z	5.38	66.97	16.63		130.0	
10619-AAA	IEEE 802.11ac WiFi (40MHz, MCS3, 90pc duty cycle)	X	5.45	66.98	16.69	0.46	130.0	± 9.6 %
		Y	5.39	66.74	16.43		130.0	
		Z	5.41	66.83	16.51		130.0	
10620-AAA	IEEE 802.11ac WiFi (40MHz, MCS4, 90pc duty cycle)	X	5.55	67.03	16.77	0.46	130.0	± 9.6 %
		Y	5.49	66.78	16.50		130.0	
		Z	5.51	66.88	16.58		130.0	
10621-AAA	IEEE 802.11ac WiFi (40MHz, MCS5, 90pc duty cycle)	X	5.51	67.03	16.86	0.46	130.0	± 9.6 %
		Y	5.46	66.84	16.63		130.0	
		Z	5.48	66.91	16.70		130.0	
10622-AAA	IEEE 802.11ac WiFi (40MHz, MCS6, 90pc duty cycle)	X	5.54	67.25	16.97	0.46	130.0	± 9.6 %
		Y	5.49	67.04	16.73		130.0	
		Z	5.50	67.11	16.80		130.0	

10623-AAA	IEEE 802.11ac WiFi (40MHz, MCS7, 90pc duty cycle)	X	5.41	66.79	16.63	0.46	130.0	± 9.6 %
		Y	5.36	66.56	16.37		130.0	
		Z	5.38	66.65	16.45		130.0	
10624-AAA	IEEE 802.11ac WiFi (40MHz, MCS8, 90pc duty cycle)	X	5.62	67.00	16.79	0.46	130.0	± 9.6 %
		Y	5.56	66.77	16.54		130.0	
		Z	5.58	66.86	16.62		130.0	
10625-AAA	IEEE 802.11ac WiFi (40MHz, MCS9, 90pc duty cycle)	X	6.10	68.33	17.51	0.46	130.0	± 9.6 %
		Y	6.00	67.98	17.19		130.0	
		Z	6.02	68.08	17.28		130.0	
10626-AAA	IEEE 802.11ac WiFi (80MHz, MCS0, 90pc duty cycle)	X	5.74	66.93	16.65	0.46	130.0	± 9.6 %
		Y	5.69	66.74	16.43		130.0	
		Z	5.71	66.82	16.50		130.0	
10627-AAA	IEEE 802.11ac WiFi (80MHz, MCS1, 90pc duty cycle)	X	6.03	67.63	16.96	0.46	130.0	± 9.6 %
		Y	5.97	67.40	16.71		130.0	
		Z	5.98	67.48	16.79		130.0	
10628-AAA	IEEE 802.11ac WiFi (80MHz, MCS2, 90pc duty cycle)	X	5.81	67.14	16.66	0.46	130.0	± 9.6 %
		Y	5.75	66.90	16.41		130.0	
		Z	5.77	67.00	16.49		130.0	
10629-AAA	IEEE 802.11ac WiFi (80MHz, MCS3, 90pc duty cycle)	X	5.89	67.21	16.69	0.46	130.0	± 9.6 %
		Y	5.84	67.00	16.45		130.0	
		Z	5.85	67.08	16.52		130.0	
10630-AAA	IEEE 802.11ac WiFi (80MHz, MCS4, 90pc duty cycle)	X	6.58	69.47	17.83	0.46	130.0	± 9.6 %
		Y	6.44	68.97	17.43		130.0	
		Z	6.47	69.10	17.53		130.0	
10631-AAA	IEEE 802.11ac WiFi (80MHz, MCS5, 90pc duty cycle)	X	6.29	68.65	17.58	0.46	130.0	± 9.6 %
		Y	6.21	68.38	17.32		130.0	
		Z	6.23	68.46	17.39		130.0	
10632-AAA	IEEE 802.11ac WiFi (80MHz, MCS6, 90pc duty cycle)	X	5.97	67.59	17.06	0.46	130.0	± 9.6 %
		Y	5.92	67.40	16.84		130.0	
		Z	5.93	67.46	16.90		130.0	
10633-AAA	IEEE 802.11ac WiFi (80MHz, MCS7, 90pc duty cycle)	X	5.86	67.25	16.74	0.46	130.0	± 9.6 %
		Y	5.80	67.03	16.49		130.0	
		Z	5.82	67.11	16.57		130.0	
10634-AAA	IEEE 802.11ac WiFi (80MHz, MCS8, 90pc duty cycle)	X	5.83	67.23	16.78	0.46	130.0	± 9.6 %
		Y	5.78	67.04	16.55		130.0	
		Z	5.80	67.11	16.62		130.0	
10635-AAA	IEEE 802.11ac WiFi (80MHz, MCS9, 90pc duty cycle)	X	5.74	66.71	16.29	0.46	130.0	± 9.6 %
		Y	5.68	66.44	16.01		130.0	
		Z	5.70	66.56	16.11		130.0	
10636-AAA	IEEE 1602.11ac WiFi (160MHz, MCS0, 90pc duty cycle)	X	6.17	67.34	16.76	0.46	130.0	± 9.6 %
		Y	6.11	67.15	16.53		130.0	
		Z	6.13	67.22	16.60		130.0	
10637-AAA	IEEE 1602.11ac WiFi (160MHz, MCS1, 90pc duty cycle)	X	6.35	67.79	16.97	0.46	130.0	± 9.6 %
		Y	6.29	67.57	16.73		130.0	
		Z	6.30	67.65	16.80		130.0	
10638-AAA	IEEE 1602.11ac WiFi (160MHz, MCS2, 90pc duty cycle)	X	6.35	67.77	16.94	0.46	130.0	± 9.6 %
		Y	6.29	67.54	16.69		130.0	
		Z	6.30	67.62	16.76		130.0	

10639-AAA	IIEEE 1602.11ac WiFi (160MHz, MCS3, 90pc duty cycle)	X	6.32	67.69	16.93	0.46	130.0	± 9.6 %
		Y	6.26	67.48	16.70		130.0	
		Z	6.28	67.56	16.77		130.0	
10640-AAA	IIEEE 1602.11ac WiFi (160MHz, MCS4, 90pc duty cycle)	X	6.35	67.80	16.94	0.46	130.0	± 9.6 %
		Y	6.28	67.54	16.68		130.0	
		Z	6.30	67.64	16.76		130.0	
10641-AAA	IIEEE 1602.11ac WiFi (160MHz, MCS5, 90pc duty cycle)	X	6.36	67.58	16.85	0.46	130.0	± 9.6 %
		Y	6.30	67.37	16.61		130.0	
		Z	6.32	67.45	16.69		130.0	
10642-AAA	IIEEE 1602.11ac WiFi (160MHz, MCS6, 90pc duty cycle)	X	6.40	67.80	17.11	0.46	130.0	± 9.6 %
		Y	6.34	67.61	16.89		130.0	
		Z	6.36	67.68	16.96		130.0	
10643-AAA	IIEEE 1602.11ac WiFi (160MHz, MCS7, 90pc duty cycle)	X	6.25	67.58	16.92	0.46	130.0	± 9.6 %
		Y	6.19	67.34	16.66		130.0	
		Z	6.21	67.43	16.74		130.0	
10644-AAA	IIEEE 1602.11ac WiFi (160MHz, MCS8, 90pc duty cycle)	X	6.47	68.26	17.28	0.46	130.0	± 9.6 %
		Y	6.39	67.96	16.99		130.0	
		Z	6.42	68.06	17.08		130.0	
10645-AAA	IIEEE 1602.11ac WiFi (160MHz, MCS9, 90pc duty cycle)	X	7.06	69.52	17.87	0.46	130.0	± 9.6 %
		Y	6.93	69.10	17.52		130.0	
		Z	6.96	69.22	17.62		130.0	
10646-AAC	LTE-TDD (SC-FDMA, 1 RB, 5 MHz, QPSK, UL Subframe=2,7)	X	100.00	148.85	48.77	9.30	60.0	± 9.6 %
		Y	80.54	141.06	46.17		60.0	
		Z	100.00	148.08	48.38		60.0	
10647-AAB	LTE-TDD (SC-FDMA, 1 RB, 20 MHz, QPSK, UL Subframe=2,7)	X	100.00	150.12	49.32	9.30	60.0	± 9.6 %
		Y	73.97	140.10	46.12		60.0	
		Z	100.00	149.31	48.92		60.0	
10648-AAA	CDMA2000 (1x Advanced)	X	0.92	66.97	13.32	0.00	150.0	± 9.6 %
		Y	0.75	63.96	11.29		150.0	
		Z	0.80	64.80	11.93		150.0	

^E Uncertainty is determined using the max. deviation from linear response applying rectangular distribution and is expressed for the square of the field value.



Accredited by the Swiss Accreditation Service (SAS)
The Swiss Accreditation Service is one of the signatories to the EA
Multilateral Agreement for the recognition of calibration certificates

Accreditation No.: **SCS 0108**

Client **PC Test**

Certificate No: **EX3-7308_Aug17**

CALIBRATION CERTIFICATE

Object: **EX3DV4 - SN:7308**

Calibration procedure(s): **QA CAL-01.v9, QA CAL-14.v4, QA CAL-23.v5, QA CAL-25.v6
Calibration procedure for dosimetric E-field probes**

*PNV
8/27/17*

Calibration date: **August 16, 2017**

This calibration certificate documents the traceability to national standards, which realize the physical units of measurements (SI).
The measurements and the uncertainties with confidence probability are given on the following pages and are part of the certificate.

All calibrations have been conducted in the closed laboratory facility: environment temperature (22 ± 3)°C and humidity < 70%.

Calibration Equipment used (M&TE critical for calibration)

Primary Standards	ID	Cal Date (Certificate No.)	Scheduled Calibration
Power meter NRP	SN: 104778	04-Apr-17 (No. 217-02521/02522)	Apr-18
Power sensor NRP-Z91	SN: 103244	04-Apr-17 (No. 217-02521)	Apr-18
Power sensor NRP-Z91	SN: 103245	04-Apr-17 (No. 217-02525)	Apr-18
Reference 20 dB Attenuator	SN: S5277 (20x)	07-Apr-17 (No. 217-02528)	Apr-18
Reference Probe ES3DV2	SN: 3013	31-Dec-16 (No. ES3-3013_Dec16)	Dec-17
DAE4	SN: 660	7-Dec-16 (No. DAE4-660_Dec16)	Dec-17
Secondary Standards	ID	Check Date (in house)	Scheduled Check
Power meter E4419B	SN: GB41293874	06-Apr-16 (in house check Jun-16)	In house check: Jun-18
Power sensor E4412A	SN: MY41498087	06-Apr-16 (in house check Jun-16)	In house check: Jun-18
Power sensor E4412A	SN: 000110210	06-Apr-16 (in house check Jun-16)	In house check: Jun-18
RF generator HP 8648C	SN: US3642U01700	04-Aug-99 (in house check Jun-16)	In house check: Jun-18
Network Analyzer HP 8753E	SN: US37390585	18-Oct-01 (in house check Oct-16)	In house check: Oct-17

Calibrated by:	Name Leif Klysnar	Function Laboratory Technician	Signature <i>Leif Klysnar</i>
Approved by:	Name Katja Pokovic	Function Technical Manager	Signature <i>Katja Pokovic</i>
			Issued: August 16, 2017
This calibration certificate shall not be reproduced except in full without written approval of the laboratory.			



Accredited by the Swiss Accreditation Service (SAS)

Accreditation No.: **SCS 0108**

The Swiss Accreditation Service is one of the signatories to the EA
Multilateral Agreement for the recognition of calibration certificates

Glossary:

TSL	tissue simulating liquid
NORM _{x,y,z}	sensitivity in free space
ConvF	sensitivity in TSL / NORM _{x,y,z}
DCP	diode compression point
CF	crest factor (1/duty_cycle) of the RF signal
A, B, C, D	modulation dependent linearization parameters
Polarization φ	φ rotation around probe axis
Polarization ϑ	ϑ rotation around an axis that is in the plane normal to probe axis (at measurement center), i.e., $\vartheta = 0$ is normal to probe axis
Connector Angle	information used in DASY system to align probe sensor X to the robot coordinate system

Calibration is Performed According to the Following Standards:

- a) IEEE Std 1528-2013, "IEEE Recommended Practice for Determining the Peak Spatial-Averaged Specific Absorption Rate (SAR) in the Human Head from Wireless Communications Devices: Measurement Techniques", June 2013
- b) IEC 62209-1, "Measurement procedure for the assessment of Specific Absorption Rate (SAR) from hand-held and body-mounted devices used next to the ear (frequency range of 300 MHz to 6 GHz)", July 2016
- c) IEC 62209-2, "Procedure to determine the Specific Absorption Rate (SAR) for wireless communication devices used in close proximity to the human body (frequency range of 30 MHz to 6 GHz)", March 2010
- d) KDB 865664, "SAR Measurement Requirements for 100 MHz to 6 GHz"

Methods Applied and Interpretation of Parameters:

- *NORM_{x,y,z}*: Assessed for E-field polarization $\vartheta = 0$ ($f \leq 900$ MHz in TEM-cell; $f > 1800$ MHz: R22 waveguide). *NORM_{x,y,z}* are only intermediate values, i.e., the uncertainties of *NORM_{x,y,z}* does not affect the E^2 -field uncertainty inside TSL (see below *ConvF*).
- *NORM(f)_{x,y,z} = NORM_{x,y,z} * frequency_response* (see Frequency Response Chart). This linearization is implemented in DASY4 software versions later than 4.2. The uncertainty of the frequency response is included in the stated uncertainty of *ConvF*.
- *DCP_{x,y,z}*: DCP are numerical linearization parameters assessed based on the data of power sweep with CW signal (no uncertainty required). DCP does not depend on frequency nor media.
- *PAR*: PAR is the Peak to Average Ratio that is not calibrated but determined based on the signal characteristics
- *A_{x,y,z}; B_{x,y,z}; C_{x,y,z}; D_{x,y,z}; VR_{x,y,z}; A, B, C, D* are numerical linearization parameters assessed based on the data of power sweep for specific modulation signal. The parameters do not depend on frequency nor media. VR is the maximum calibration range expressed in RMS voltage across the diode.
- *ConvF and Boundary Effect Parameters*: Assessed in flat phantom using E-field (or Temperature Transfer Standard for $f \leq 800$ MHz) and inside waveguide using analytical field distributions based on power measurements for $f > 800$ MHz. The same setups are used for assessment of the parameters applied for boundary compensation (alpha, depth) of which typical uncertainty values are given. These parameters are used in DASY4 software to improve probe accuracy close to the boundary. The sensitivity in TSL corresponds to *NORM_{x,y,z} * ConvF* whereby the uncertainty corresponds to that given for *ConvF*. A frequency dependent *ConvF* is used in DASY version 4.4 and higher which allows extending the validity from ± 50 MHz to ± 100 MHz.
- *Spherical isotropy (3D deviation from isotropy)*: in a field of low gradients realized using a flat phantom exposed by a patch antenna.
- *Sensor Offset*: The sensor offset corresponds to the offset of virtual measurement center from the probe tip (on probe axis). No tolerance required.
- *Connector Angle*: The angle is assessed using the information gained by determining the *NORM_x* (no uncertainty required).

Probe EX3DV4

SN:7308

Manufactured: March 11, 2014
Calibrated: August 16, 2017

Calibrated for DASY/EASY Systems
(Note: non-compatible with DASY2 system!)

DASY/EASY - Parameters of Probe: EX3DV4 - SN:7308

Basic Calibration Parameters

	Sensor X	Sensor Y	Sensor Z	Unc (k=2)
Norm ($\mu\text{V}/(\text{V}/\text{m})^2$) ^A	0.49	0.60	0.44	$\pm 10.1 \%$
DCP (mV) ^B	97.0	91.7	98.5	

Modulation Calibration Parameters

UID	Communication System Name		A dB	B dB $\sqrt{\mu\text{V}}$	C	D dB	VR mV	Unc ^E (k=2)
0	CW	X	0.0	0.0	1.0	0.00	134.5	$\pm 3.3 \%$
		Y	0.0	0.0	1.0		130.8	
		Z	0.0	0.0	1.0		149.9	

Note: For details on UID parameters see Appendix.

Sensor Model Parameters

	C1 fF	C2 fF	α V ⁻¹	T1 ms.V ⁻²	T2 ms.V ⁻¹	T3 ms	T4 V ⁻²	T5 V ⁻¹	T6
X	46.65	351.1	36.16	14.68	0.000	5.088	0.834	0.399	1.005
Y	52.88	402.1	36.74	19.55	0.309	5.100	0.477	0.605	1.007
Z	36.70	273.3	35.48	9.322	0.000	5.034	0.373	0.314	1.002

The reported uncertainty of measurement is stated as the standard uncertainty of measurement multiplied by the coverage factor k=2, which for a normal distribution corresponds to a coverage probability of approximately 95%.

^A The uncertainties of Norm X,Y,Z do not affect the E²-field uncertainty inside TSL (see Pages 5 and 6).

^B Numerical linearization parameter: uncertainty not required.

^E Uncertainty is determined using the max. deviation from linear response applying rectangular distribution and is expressed for the square of the field value.

DASY/EASY - Parameters of Probe: EX3DV4 - SN:7308

Calibration Parameter Determined in Head Tissue Simulating Media

f (MHz) ^C	Relative Permittivity ^F	Conductivity (S/m) ^F	ConvF X	ConvF Y	ConvF Z	Alpha ^G	Depth ^G (mm)	Unc (k=2)
5250	35.9	4.71	5.25	5.25	5.25	0.35	1.80	± 13.1 %
5600	35.5	5.07	4.83	4.83	4.83	0.40	1.80	± 13.1 %
5750	35.4	5.22	5.11	5.11	5.11	0.40	1.80	± 13.1 %

^C Frequency validity above 300 MHz of ± 100 MHz only applies for DASY v4.4 and higher (see Page 2), else it is restricted to ± 50 MHz. The uncertainty is the RSS of the ConvF uncertainty at calibration frequency and the uncertainty for the indicated frequency band. Frequency validity below 300 MHz is ± 10, 25, 40, 50 and 70 MHz for ConvF assessments at 30, 64, 128, 150 and 220 MHz respectively. Above 5 GHz frequency validity can be extended to ± 110 MHz.

^F At frequencies below 3 GHz, the validity of tissue parameters (ϵ and σ) can be relaxed to ± 10% if liquid compensation formula is applied to measured SAR values. At frequencies above 3 GHz, the validity of tissue parameters (ϵ and σ) is restricted to ± 5%. The uncertainty is the RSS of the ConvF uncertainty for indicated target tissue parameters.

^G Alpha/Depth are determined during calibration. SPEAG warrants that the remaining deviation due to the boundary effect after compensation is always less than ± 1% for frequencies below 3 GHz and below ± 2% for frequencies between 3-6 GHz at any distance larger than half the probe tip diameter from the boundary.

DASY/EASY - Parameters of Probe: EX3DV4 - SN:7308

Calibration Parameter Determined in Body Tissue Simulating Media

f (MHz) ^C	Relative Permittivity ^F	Conductivity (S/m) ^F	ConvF X	ConvF Y	ConvF Z	Alpha ^G	Depth ^G (mm)	Unc (k=2)
750	55.5	0.96	10.39	10.39	10.39	0.54	0.85	± 12.0 %
835	55.2	0.97	10.21	10.21	10.21	0.47	0.84	± 12.0 %
1750	53.4	1.49	8.24	8.24	8.24	0.41	0.84	± 12.0 %
1900	53.3	1.52	7.96	7.96	7.96	0.37	0.80	± 12.0 %
2300	52.9	1.81	7.77	7.77	7.77	0.39	0.86	± 12.0 %
2450	52.7	1.95	7.66	7.66	7.66	0.35	0.85	± 12.0 %
2600	52.5	2.16	7.46	7.46	7.46	0.31	0.95	± 12.0 %
5250	48.9	5.36	4.84	4.84	4.84	0.35	1.90	± 13.1 %
5600	48.5	5.77	4.23	4.23	4.23	0.40	1.90	± 13.1 %
5750	48.3	5.94	4.50	4.50	4.50	0.40	1.90	± 13.1 %

^C Frequency validity above 300 MHz of ± 100 MHz only applies for DASY v4.4 and higher (see Page 2), else it is restricted to ± 50 MHz. The uncertainty is the RSS of the ConvF uncertainty at calibration frequency and the uncertainty for the indicated frequency band. Frequency validity below 300 MHz is ± 10, 25, 40, 50 and 70 MHz for ConvF assessments at 30, 64, 128, 150 and 220 MHz respectively. Above 5 GHz frequency validity can be extended to ± 110 MHz.

^F At frequencies below 3 GHz, the validity of tissue parameters (ϵ and σ) can be relaxed to ± 10% if liquid compensation formula is applied to measured SAR values. At frequencies above 3 GHz, the validity of tissue parameters (ϵ and σ) is restricted to ± 5%. The uncertainty is the RSS of the ConvF uncertainty for indicated target tissue parameters.

^G Alpha/Depth are determined during calibration. SPEAG warrants that the remaining deviation due to the boundary effect after compensation is always less than ± 1% for frequencies below 3 GHz and below ± 2% for frequencies between 3-6 GHz at any distance larger than half the probe tip diameter from the boundary.

Frequency Response of E-Field (TEM-Cell:ifi110 EXX, Waveguide: R22)

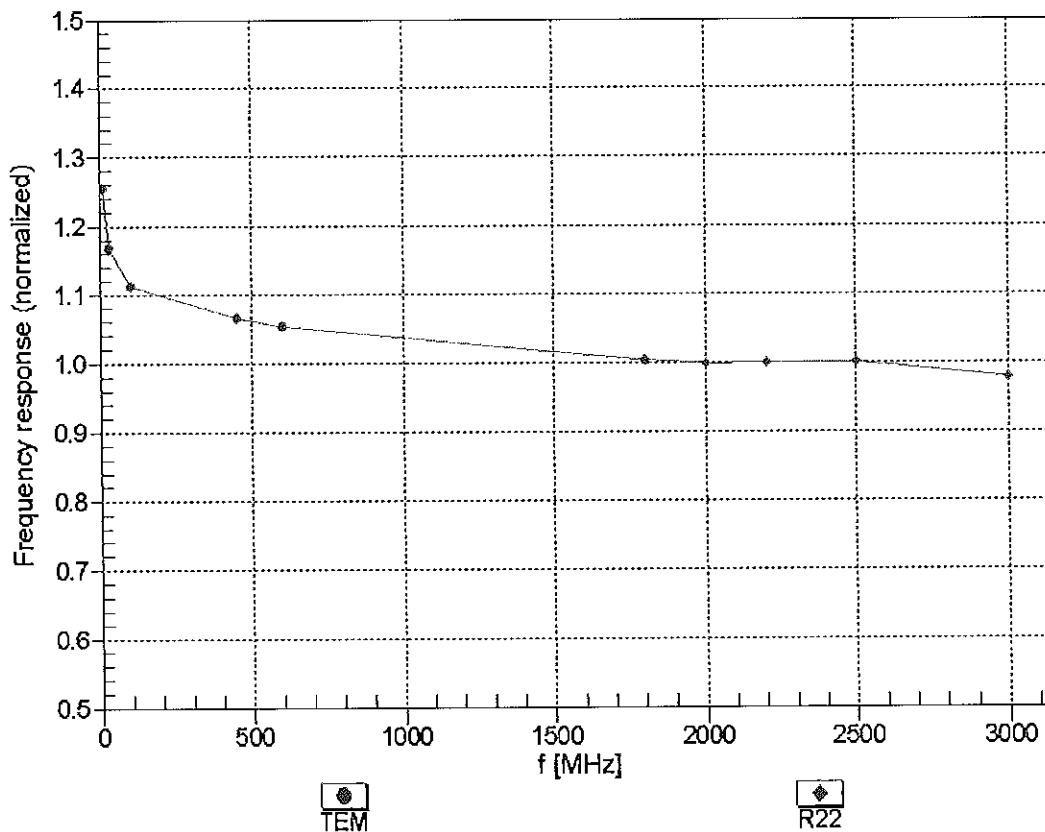

Uncertainty of Frequency Response of E-field: $\pm 6.3\%$ (k=2)

Receiving Pattern (ϕ), $\theta = 0^\circ$

f=600 MHz,TEM

f=1800 MHz,R22

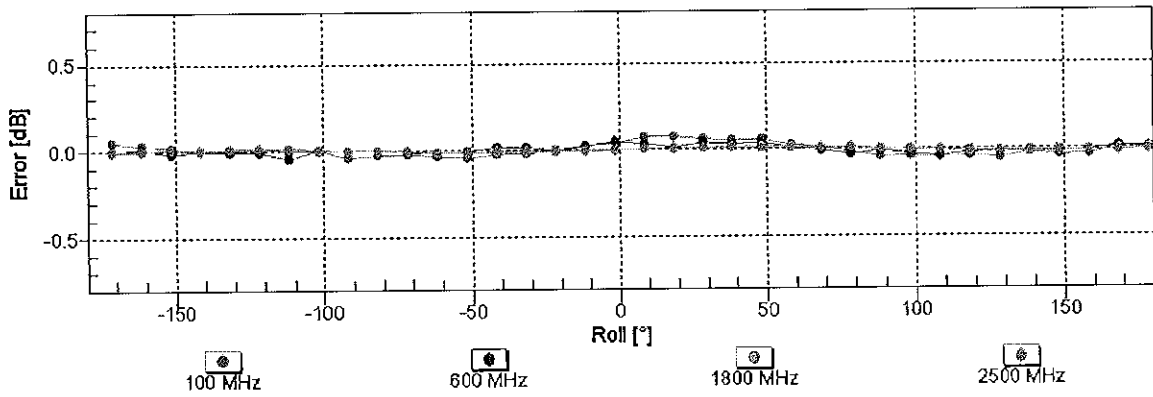
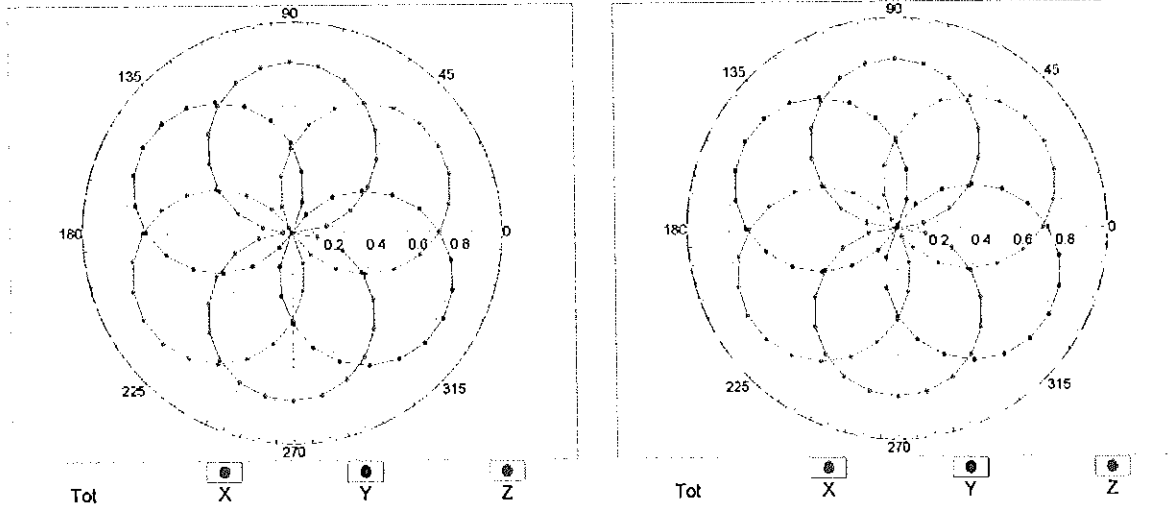

Uncertainty of Axial Isotropy Assessment: $\pm 0.5\%$ (k=2)

Dynamic Range $f(SAR_{head})$ (TEM cell , $f_{eval} = 1900$ MHz)

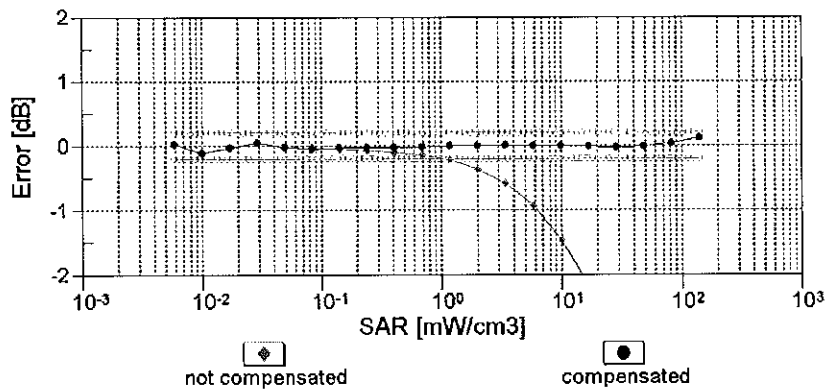
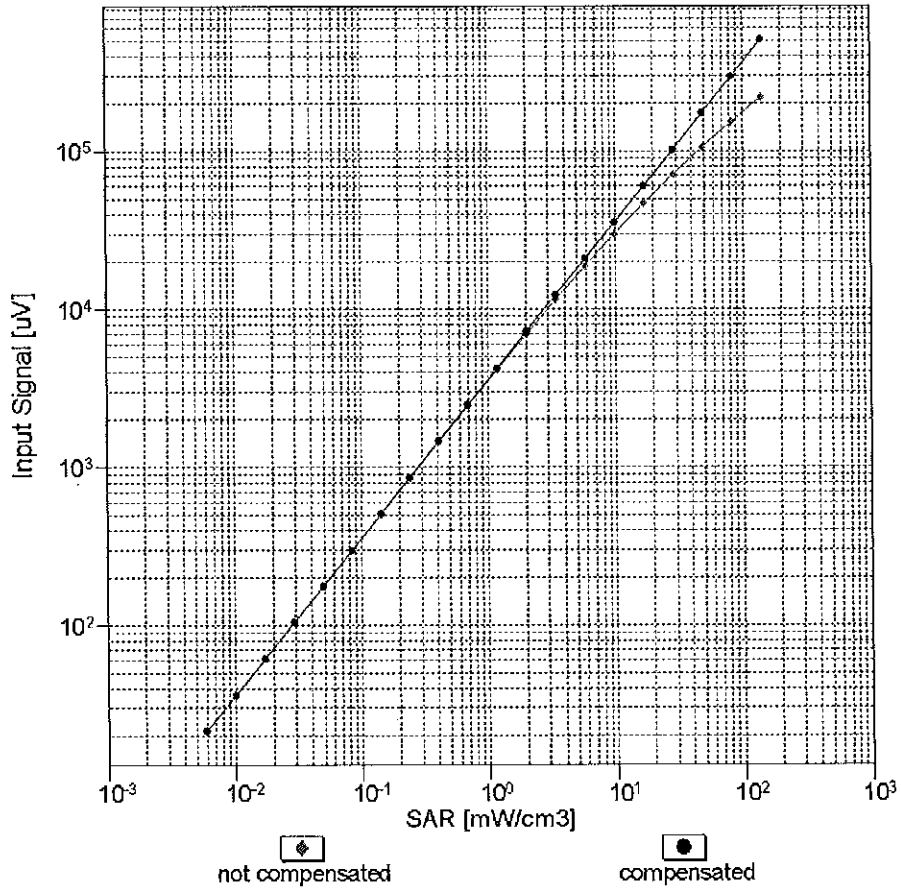

Uncertainty of Linearity Assessment: $\pm 0.6\%$ (k=2)

Conversion Factor Assessment

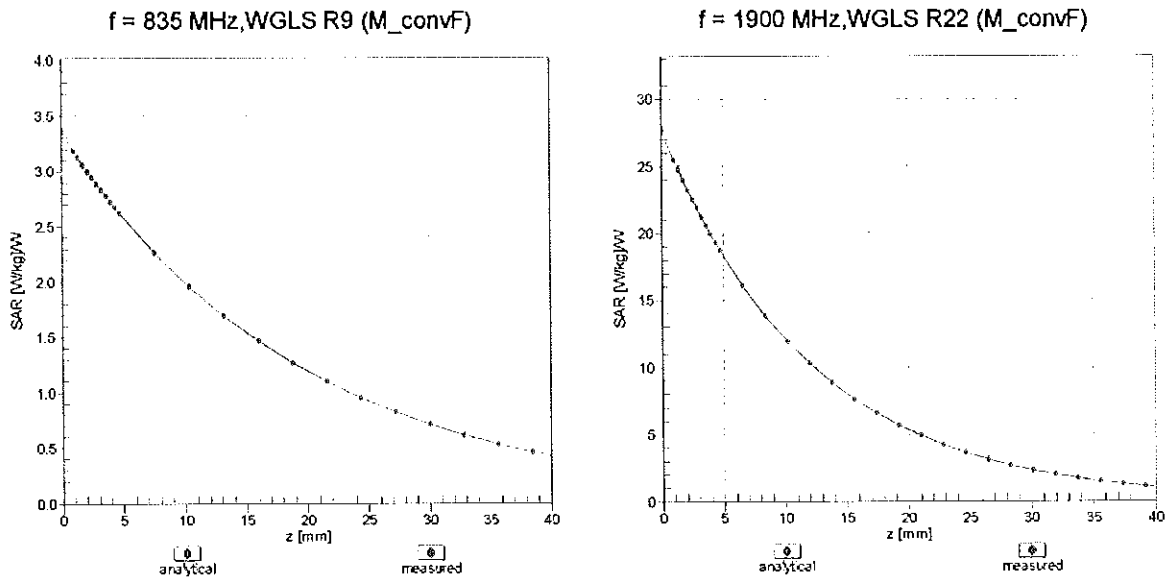

Deviation from Isotropy in Liquid Error (ϕ, θ), f = 900 MHz

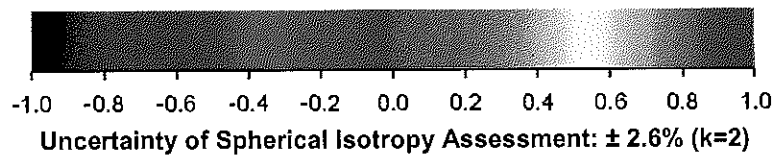
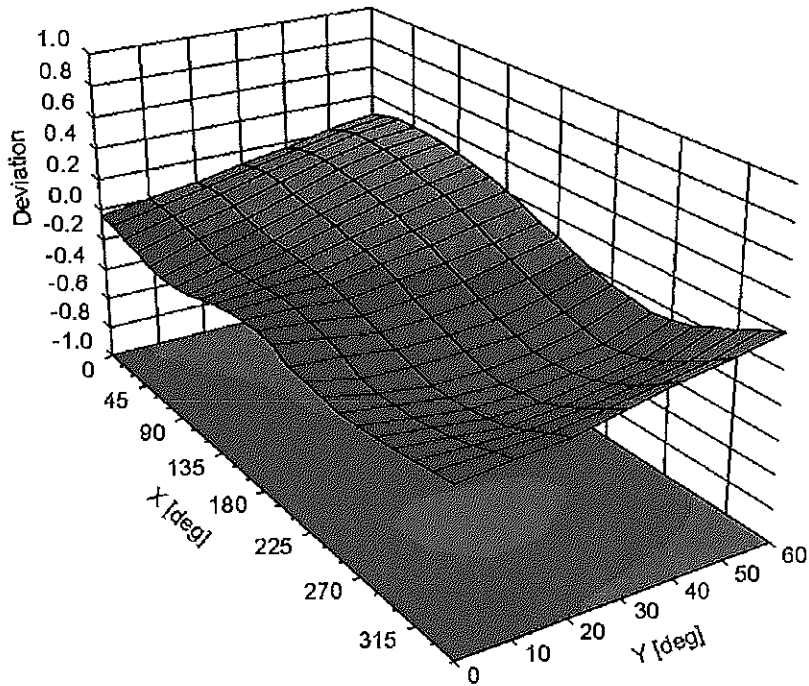

DASY/EASY - Parameters of Probe: EX3DV4 - SN:7308

Other Probe Parameters

Sensor Arrangement	Triangular
Connector Angle (°)	108.4
Mechanical Surface Detection Mode	enabled
Optical Surface Detection Mode	disabled
Probe Overall Length	337 mm
Probe Body Diameter	10 mm
Tip Length	9 mm
Tip Diameter	2.5 mm
Probe Tip to Sensor X Calibration Point	1 mm
Probe Tip to Sensor Y Calibration Point	1 mm
Probe Tip to Sensor Z Calibration Point	1 mm
Recommended Measurement Distance from Surface	1.4 mm

Appendix: Modulation Calibration Parameters

UID	Communication System Name		A dB	B dB $\sqrt{\mu V}$	C	D dB	VR mV	Max Unc ^E (k=2)
0	CW	X	0.00	0.00	1.00	0.00	134.5	$\pm 3.3\%$
		Y	0.00	0.00	1.00		130.8	
		Z	0.00	0.00	1.00		149.9	
10010- CAA	SAR Validation (Square, 100ms, 10ms)	X	2.82	69.38	11.47	10.00	20.0	$\pm 9.6\%$
		Y	8.85	81.60	16.75		20.0	
		Z	1.57	63.55	8.34		20.0	
10011- CAB	UMTS-FDD (WCDMA)	X	1.10	68.34	15.94	0.00	150.0	$\pm 9.6\%$
		Y	1.03	66.61	14.91		150.0	
		Z	1.05	68.21	15.74		150.0	
10012- CAB	IEEE 802.11b WiFi 2.4 GHz (DSSS, 1 Mbps)	X	1.19	64.20	15.65	0.41	150.0	$\pm 9.6\%$
		Y	1.20	63.83	15.29		150.0	
		Z	1.16	63.91	15.33		150.0	
10013- CAB	IEEE 802.11g WiFi 2.4 GHz (DSSS-OFDM, 6 Mbps)	X	4.89	66.77	17.26	1.46	150.0	$\pm 9.6\%$
		Y	4.97	66.66	17.21		150.0	
		Z	4.71	66.76	17.06		150.0	
10021- DAC	GSM-FDD (TDMA, GMSK)	X	100.00	115.21	27.27	9.39	50.0	$\pm 9.6\%$
		Y	100.00	118.99	29.62		50.0	
		Z	100.00	108.16	23.75		50.0	
10023- DAC	GPRS-FDD (TDMA, GMSK, TN 0)	X	100.00	114.49	26.98	9.57	50.0	$\pm 9.6\%$
		Y	100.00	118.59	29.46		50.0	
		Z	100.00	107.44	23.48		50.0	
10024- DAC	GPRS-FDD (TDMA, GMSK, TN 0-1)	X	100.00	117.36	27.41	6.56	60.0	$\pm 9.6\%$
		Y	100.00	118.20	28.43		60.0	
		Z	100.00	109.72	23.49		60.0	
10025- DAC	EDGE-FDD (TDMA, 8PSK, TN 0)	X	9.43	102.43	43.37	12.57	50.0	$\pm 9.6\%$
		Y	5.76	81.81	33.21		50.0	
		Z	6.64	89.92	37.39		50.0	
10026- DAC	EDGE-FDD (TDMA, 8PSK, TN 0-1)	X	12.23	103.58	38.33	9.56	60.0	$\pm 9.6\%$
		Y	13.89	103.56	37.54		60.0	
		Z	6.87	89.09	32.73		60.0	
10027- DAC	GPRS-FDD (TDMA, GMSK, TN 0-1-2)	X	100.00	121.12	28.38	4.80	80.0	$\pm 9.6\%$
		Y	100.00	119.35	28.26		80.0	
		Z	100.00	113.58	24.47		80.0	
10028- DAC	GPRS-FDD (TDMA, GMSK, TN 0-1-2-3)	X	100.00	126.40	29.97	3.55	100.0	$\pm 9.6\%$
		Y	100.00	121.68	28.61		100.0	
		Z	100.00	119.83	26.46		100.0	
10029- DAC	EDGE-FDD (TDMA, 8PSK, TN 0-1-2)	X	6.36	85.88	30.18	7.80	80.0	$\pm 9.6\%$
		Y	7.77	88.44	30.64		80.0	
		Z	4.37	77.58	26.51		80.0	
10030- CAA	IEEE 802.15.1 Bluetooth (GFSK, DH1)	X	100.00	116.71	26.74	5.30	70.0	$\pm 9.6\%$
		Y	100.00	116.86	27.45		70.0	
		Z	100.00	108.46	22.53		70.0	
10031- CAA	IEEE 802.15.1 Bluetooth (GFSK, DH3)	X	100.00	130.68	30.26	1.88	100.0	$\pm 9.6\%$
		Y	100.00	122.76	27.68		100.0	
		Z	100.00	121.33	25.72		100.0	

10032-CAA	IEEE 802.15.1 Bluetooth (GFSK, DH5)	X	100.00	146.47	35.43	1.17	100.0	± 9.6 %
		Y	100.00	130.05	29.64		100.0	
		Z	100.00	142.38	32.95		100.0	
10033-CAA	IEEE 802.15.1 Bluetooth (PI/4-DQPSK, DH1)	X	100.00	133.81	36.67	5.30	70.0	± 9.6 %
		Y	100.00	132.56	36.57		70.0	
		Z	18.79	102.95	27.19		70.0	
10034-CAA	IEEE 802.15.1 Bluetooth (PI/4-DQPSK, DH3)	X	7.76	92.37	23.91	1.88	100.0	± 9.6 %
		Y	6.00	87.65	22.68		100.0	
		Z	3.22	78.87	18.00		100.0	
10035-CAA	IEEE 802.15.1 Bluetooth (PI/4-DQPSK, DH5)	X	3.37	81.04	19.87	1.17	100.0	± 9.6 %
		Y	2.89	77.85	18.94		100.0	
		Z	2.06	74.00	15.93		100.0	
10036-CAA	IEEE 802.15.1 Bluetooth (8-DPSK, DH1)	X	100.00	134.35	36.91	5.30	70.0	± 9.6 %
		Y	100.00	133.01	36.79		70.0	
		Z	38.41	113.99	30.14		70.0	
10037-CAA	IEEE 802.15.1 Bluetooth (8-DPSK, DH3)	X	6.72	90.40	23.29	1.88	100.0	± 9.6 %
		Y	5.52	86.51	22.28		100.0	
		Z	2.77	77.09	17.35		100.0	
10038-CAA	IEEE 802.15.1 Bluetooth (8-DPSK, DH5)	X	3.40	81.53	20.18	1.17	100.0	± 9.6 %
		Y	2.93	78.34	19.24		100.0	
		Z	2.07	74.35	16.21		100.0	
10039-CAB	CDMA2000 (1xRTT, RC1)	X	2.05	73.74	16.48	0.00	150.0	± 9.6 %
		Y	1.78	70.97	15.59		150.0	
		Z	1.68	71.87	14.68		150.0	
10042-CAB	IS-54 / IS-136 FDD (TDMA/FDM, PI/4-DQPSK, Halfrate)	X	100.00	111.92	25.18	7.78	50.0	± 9.6 %
		Y	100.00	114.62	26.97		50.0	
		Z	100.00	105.38	21.87		50.0	
10044-CAA	IS-91/EIA/TIA-553 FDD (FDMA, FM)	X	0.00	97.13	0.41	0.00	150.0	± 9.6 %
		Y	0.00	93.19	1.28		150.0	
		Z	0.01	94.96	0.54		150.0	
10048-CAA	DECT (TDD, TDMA/FDM, GFSK, Full Slot, 24)	X	100.00	111.98	26.96	13.80	25.0	± 9.6 %
		Y	100.00	121.05	31.60		25.0	
		Z	34.07	91.91	20.28		25.0	
10049-CAA	DECT (TDD, TDMA/FDM, GFSK, Double Slot, 12)	X	1284.72	142.21	32.21	10.79	40.0	± 9.6 %
		Y	100.00	117.51	29.18		40.0	
		Z	145.96	109.32	23.74		40.0	
10056-CAA	UMTS-TDD (TD-SCDMA, 1.28 Mcps)	X	100.00	128.20	35.15	9.03	50.0	± 9.6 %
		Y	100.00	128.83	35.96		50.0	
		Z	100.00	122.10	31.77		50.0	
10058-DAC	EDGE-FDD (TDMA, 8PSK, TN 0-1-2-3)	X	4.71	78.88	26.31	6.55	100.0	± 9.6 %
		Y	5.67	81.33	26.92		100.0	
		Z	3.54	73.15	23.60		100.0	
10059-CAB	IEEE 802.11b WiFi 2.4 GHz (DSSS, 2 Mbps)	X	1.24	65.47	16.42	0.61	110.0	± 9.6 %
		Y	1.27	65.23	16.10		110.0	
		Z	1.17	64.77	15.84		110.0	
10060-CAB	IEEE 802.11b WiFi 2.4 GHz (DSSS, 5.5 Mbps)	X	100.00	144.38	38.50	1.30	110.0	± 9.6 %
		Y	100.00	138.88	36.40		110.0	
		Z	13.09	112.30	30.84		110.0	

10061-CAB	IEEE 802.11b WiFi 2.4 GHz (DSSS, 11 Mbps)	X	4.05	88.33	25.97	2.04	110.0	± 9.6 %
		Y	4.75	88.86	25.68		110.0	
		Z	2.16	77.73	21.68		110.0	
10062-CAB	IEEE 802.11a/h WiFi 5 GHz (OFDM, 6 Mbps)	X	4.69	66.76	16.65	0.49	100.0	± 9.6 %
		Y	4.76	66.60	16.58		100.0	
		Z	4.53	66.78	16.51		100.0	
10063-CAB	IEEE 802.11a/h WiFi 5 GHz (OFDM, 9 Mbps)	X	4.71	66.86	16.76	0.72	100.0	± 9.6 %
		Y	4.78	66.72	16.70		100.0	
		Z	4.54	66.86	16.60		100.0	
10064-CAB	IEEE 802.11a/h WiFi 5 GHz (OFDM, 12 Mbps)	X	4.99	67.12	16.99	0.86	100.0	± 9.6 %
		Y	5.09	67.02	16.95		100.0	
		Z	4.78	67.06	16.80		100.0	
10065-CAB	IEEE 802.11a/h WiFi 5 GHz (OFDM, 18 Mbps)	X	4.86	67.02	17.11	1.21	100.0	± 9.6 %
		Y	4.96	66.95	17.08		100.0	
		Z	4.65	66.90	16.87		100.0	
10066-CAB	IEEE 802.11a/h WiFi 5 GHz (OFDM, 24 Mbps)	X	4.88	67.05	17.29	1.46	100.0	± 9.6 %
		Y	4.99	66.99	17.27		100.0	
		Z	4.65	66.88	17.02		100.0	
10067-CAB	IEEE 802.11a/h WiFi 5 GHz (OFDM, 36 Mbps)	X	5.16	67.22	17.75	2.04	100.0	± 9.6 %
		Y	5.27	67.12	17.71		100.0	
		Z	4.93	67.13	17.49		100.0	
10068-CAB	IEEE 802.11a/h WiFi 5 GHz (OFDM, 48 Mbps)	X	5.20	67.26	17.98	2.55	100.0	± 9.6 %
		Y	5.34	67.28	18.00		100.0	
		Z	4.95	67.02	17.64		100.0	
10069-CAB	IEEE 802.11a/h WiFi 5 GHz (OFDM, 54 Mbps)	X	5.28	67.26	18.18	2.67	100.0	± 9.6 %
		Y	5.42	67.23	18.17		100.0	
		Z	5.02	67.05	17.83		100.0	
10071-CAB	IEEE 802.11g WiFi 2.4 GHz (DSSS/OFDM, 9 Mbps)	X	4.98	66.86	17.58	1.99	100.0	± 9.6 %
		Y	5.07	66.77	17.55		100.0	
		Z	4.79	66.80	17.35		100.0	
10072-CAB	IEEE 802.11g WiFi 2.4 GHz (DSSS/OFDM, 12 Mbps)	X	4.95	67.19	17.81	2.30	100.0	± 9.6 %
		Y	5.06	67.16	17.80		100.0	
		Z	4.74	67.03	17.53		100.0	
10073-CAB	IEEE 802.11g WiFi 2.4 GHz (DSSS/OFDM, 18 Mbps)	X	5.00	67.34	18.16	2.83	100.0	± 9.6 %
		Y	5.12	67.33	18.16		100.0	
		Z	4.79	67.17	17.85		100.0	
10074-CAB	IEEE 802.11g WiFi 2.4 GHz (DSSS/OFDM, 24 Mbps)	X	4.97	67.20	18.31	3.30	100.0	± 9.6 %
		Y	5.10	67.22	18.33		100.0	
		Z	4.78	67.07	17.99		100.0	
10075-CAB	IEEE 802.11g WiFi 2.4 GHz (DSSS/OFDM, 36 Mbps)	X	5.00	67.30	18.63	3.82	90.0	± 9.6 %
		Y	5.15	67.40	18.70		90.0	
		Z	4.78	67.05	18.23		90.0	
10076-CAB	IEEE 802.11g WiFi 2.4 GHz (DSSS/OFDM, 48 Mbps)	X	5.00	67.05	18.74	4.15	90.0	± 9.6 %
		Y	5.14	67.12	18.78		90.0	
		Z	4.81	66.90	18.39		90.0	
10077-CAB	IEEE 802.11g WiFi 2.4 GHz (DSSS/OFDM, 54 Mbps)	X	5.02	67.11	18.84	4.30	90.0	± 9.6 %
		Y	5.16	67.16	18.87		90.0	
		Z	4.84	66.97	18.50		90.0	

10081-CAB	CDMA2000 (1xRTT, RC3)	X	0.91	67.10	13.23	0.00	150.0	± 9.6 %
		Y	0.87	65.55	12.69		150.0	
		Z	0.76	65.80	11.60		150.0	
10082-CAB	IS-54 / IS-136 FDD (TDMA/FDM, PI/4-DQPSK, Fullrate)	X	0.67	60.00	4.34	4.77	80.0	± 9.6 %
		Y	0.83	60.00	4.98		80.0	
		Z	1.32	62.68	4.53		80.0	
10090-DAC	GPRS-FDD (TDMA, GMSK, TN 0-4)	X	100.00	117.37	27.43	6.56	60.0	± 9.6 %
		Y	100.00	118.23	28.46		60.0	
		Z	100.00	109.70	23.50		60.0	
10097-CAB	UMTS-FDD (HSDPA)	X	1.89	68.18	16.03	0.00	150.0	± 9.6 %
		Y	1.82	67.06	15.47		150.0	
		Z	1.87	68.73	15.97		150.0	
10098-CAB	UMTS-FDD (HSUPA, Subtest 2)	X	1.85	68.15	16.01	0.00	150.0	± 9.6 %
		Y	1.78	67.01	15.43		150.0	
		Z	1.83	68.68	15.95		150.0	
10099-DAC	EDGE-FDD (TDMA, 8PSK, TN 0-4)	X	12.41	103.93	38.44	9.56	60.0	± 9.6 %
		Y	14.05	103.81	37.62		60.0	
		Z	6.94	89.30	32.81		60.0	
10100-CAD	LTE-FDD (SC-FDMA, 100% RB, 20 MHz, QPSK)	X	3.20	70.68	16.98	0.00	150.0	± 9.6 %
		Y	3.15	69.96	16.53		150.0	
		Z	3.05	70.44	16.91		150.0	
10101-CAD	LTE-FDD (SC-FDMA, 100% RB, 20 MHz, 16-QAM)	X	3.27	67.67	16.10	0.00	150.0	± 9.6 %
		Y	3.29	67.34	15.87		150.0	
		Z	3.15	67.56	16.02		150.0	
10102-CAD	LTE-FDD (SC-FDMA, 100% RB, 20 MHz, 64-QAM)	X	3.37	67.61	16.17	0.00	150.0	± 9.6 %
		Y	3.39	67.30	15.96		150.0	
		Z	3.26	67.54	16.10		150.0	
10103-CAD	LTE-TDD (SC-FDMA, 100% RB, 20 MHz, QPSK)	X	6.70	77.76	21.71	3.98	65.0	± 9.6 %
		Y	7.25	78.01	21.66		65.0	
		Z	5.31	74.49	20.24		65.0	
10104-CAD	LTE-TDD (SC-FDMA, 100% RB, 20 MHz, 16-QAM)	X	6.39	74.88	21.30	3.98	65.0	± 9.6 %
		Y	7.01	75.63	21.49		65.0	
		Z	5.41	72.53	20.08		65.0	
10105-CAD	LTE-TDD (SC-FDMA, 100% RB, 20 MHz, 64-QAM)	X	5.93	73.22	20.87	3.98	65.0	± 9.6 %
		Y	6.37	73.62	20.93		65.0	
		Z	4.98	70.66	19.52		65.0	
10108-CAE	LTE-FDD (SC-FDMA, 100% RB, 10 MHz, QPSK)	X	2.79	69.92	16.81	0.00	150.0	± 9.6 %
		Y	2.76	69.17	16.35		150.0	
		Z	2.63	69.76	16.75		150.0	
10109-CAE	LTE-FDD (SC-FDMA, 100% RB, 10 MHz, 16-QAM)	X	2.93	67.55	16.01	0.00	150.0	± 9.6 %
		Y	2.94	67.14	15.76		150.0	
		Z	2.80	67.54	15.90		150.0	
10110-CAE	LTE-FDD (SC-FDMA, 100% RB, 5 MHz, QPSK)	X	2.27	69.10	16.46	0.00	150.0	± 9.6 %
		Y	2.25	68.23	15.96		150.0	
		Z	2.13	69.06	16.32		150.0	
10111-CAE	LTE-FDD (SC-FDMA, 100% RB, 5 MHz, 16-QAM)	X	2.65	68.45	16.32	0.00	150.0	± 9.6 %
		Y	2.64	67.76	16.00		150.0	
		Z	2.55	68.78	16.20		150.0	

10112-CAE	LTE-FDD (SC-FDMA, 100% RB, 10 MHz, 64-QAM)	X	3.05	67.53	16.06	0.00	150.0	± 9.6 %
		Y	3.07	67.13	15.82		150.0	
		Z	2.92	67.58	15.97		150.0	
10113-CAE	LTE-FDD (SC-FDMA, 100% RB, 5 MHz, 64-QAM)	X	2.80	68.56	16.43	0.00	150.0	± 9.6 %
		Y	2.80	67.90	16.13		150.0	
		Z	2.69	68.93	16.32		150.0	
10114-CAB	IEEE 802.11n (HT Greenfield, 13.5 Mbps, BPSK)	X	5.15	67.26	16.54	0.00	150.0	± 9.6 %
		Y	5.19	67.08	16.42		150.0	
		Z	4.99	67.20	16.47		150.0	
10115-CAB	IEEE 802.11n (HT Greenfield, 81 Mbps, 16-QAM)	X	5.43	67.37	16.60	0.00	150.0	± 9.6 %
		Y	5.52	67.34	16.56		150.0	
		Z	5.24	67.27	16.51		150.0	
10116-CAB	IEEE 802.11n (HT Greenfield, 135 Mbps, 64-QAM)	X	5.24	67.44	16.56	0.00	150.0	± 9.6 %
		Y	5.30	67.32	16.46		150.0	
		Z	5.08	67.39	16.50		150.0	
10117-CAB	IEEE 802.11n (HT Mixed, 13.5 Mbps, BPSK)	X	5.11	67.11	16.48	0.00	150.0	± 9.6 %
		Y	5.16	66.99	16.39		150.0	
		Z	4.99	67.15	16.47		150.0	
10118-CAB	IEEE 802.11n (HT Mixed, 81 Mbps, 16-QAM)	X	5.51	67.58	16.71	0.00	150.0	± 9.6 %
		Y	5.61	67.54	16.67		150.0	
		Z	5.31	67.44	16.61		150.0	
10119-CAB	IEEE 802.11n (HT Mixed, 135 Mbps, 64-QAM)	X	5.22	67.40	16.54	0.00	150.0	± 9.6 %
		Y	5.27	67.25	16.44		150.0	
		Z	5.07	67.38	16.51		150.0	
10140-CAD	LTE-FDD (SC-FDMA, 100% RB, 15 MHz, 16-QAM)	X	3.41	67.63	16.10	0.00	150.0	± 9.6 %
		Y	3.43	67.31	15.88		150.0	
		Z	3.28	67.57	16.02		150.0	
10141-CAD	LTE-FDD (SC-FDMA, 100% RB, 15 MHz, 64-QAM)	X	3.53	67.71	16.25	0.00	150.0	± 9.6 %
		Y	3.55	67.40	16.05		150.0	
		Z	3.40	67.71	16.20		150.0	
10142-CAD	LTE-FDD (SC-FDMA, 100% RB, 3 MHz, QPSK)	X	2.05	69.21	16.15	0.00	150.0	± 9.6 %
		Y	2.02	68.14	15.65		150.0	
		Z	1.90	69.18	15.79		150.0	
10143-CAD	LTE-FDD (SC-FDMA, 100% RB, 3 MHz, 16-QAM)	X	2.53	69.32	16.06	0.00	150.0	± 9.6 %
		Y	2.50	68.40	15.76		150.0	
		Z	2.39	69.52	15.59		150.0	
10144-CAD	LTE-FDD (SC-FDMA, 100% RB, 3 MHz, 64-QAM)	X	2.28	66.94	14.41	0.00	150.0	± 9.6 %
		Y	2.31	66.41	14.31		150.0	
		Z	2.06	66.49	13.57		150.0	
10145-CAE	LTE-FDD (SC-FDMA, 100% RB, 1.4 MHz, QPSK)	X	1.26	65.57	12.06	0.00	150.0	± 9.6 %
		Y	1.33	65.51	12.47		150.0	
		Z	0.90	62.72	9.31		150.0	
10146-CAE	LTE-FDD (SC-FDMA, 100% RB, 1.4 MHz, 16-QAM)	X	1.87	65.71	11.26	0.00	150.0	± 9.6 %
		Y	2.34	67.84	13.03		150.0	
		Z	1.05	60.97	7.27		150.0	
10147-CAE	LTE-FDD (SC-FDMA, 100% RB, 1.4 MHz, 64-QAM)	X	2.17	67.47	12.23	0.00	150.0	± 9.6 %
		Y	2.79	70.16	14.23		150.0	
		Z	1.11	61.38	7.60		150.0	

10149-CAD	LTE-FDD (SC-FDMA, 50% RB, 20 MHz, 16-QAM)	X	2.93	67.61	16.06	0.00	150.0	± 9.6 %
		Y	2.95	67.20	15.81		150.0	
		Z	2.81	67.60	15.95		150.0	
10150-CAD	LTE-FDD (SC-FDMA, 50% RB, 20 MHz, 64-QAM)	X	3.06	67.58	16.10	0.00	150.0	± 9.6 %
		Y	3.08	67.18	15.86		150.0	
		Z	2.93	67.64	16.01		150.0	
10151-CAD	LTE-TDD (SC-FDMA, 50% RB, 20 MHz, QPSK)	X	7.47	81.50	23.31	3.98	65.0	± 9.6 %
		Y	8.13	81.64	23.19		65.0	
		Z	5.82	78.02	21.74		65.0	
10152-CAD	LTE-TDD (SC-FDMA, 50% RB, 20 MHz, 16-QAM)	X	5.96	75.09	21.13	3.98	65.0	± 9.6 %
		Y	6.59	75.82	21.34		65.0	
		Z	4.95	72.53	19.69		65.0	
10153-CAD	LTE-TDD (SC-FDMA, 50% RB, 20 MHz, 64-QAM)	X	6.33	76.00	21.87	3.98	65.0	± 9.6 %
		Y	6.98	76.72	22.08		65.0	
		Z	5.31	73.57	20.52		65.0	
10154-CAE	LTE-FDD (SC-FDMA, 50% RB, 10 MHz, QPSK)	X	2.32	69.50	16.70	0.00	150.0	± 9.6 %
		Y	2.30	68.63	16.21		150.0	
		Z	2.17	69.43	16.55		150.0	
10155-CAE	LTE-FDD (SC-FDMA, 50% RB, 10 MHz, 16-QAM)	X	2.65	68.47	16.34	0.00	150.0	± 9.6 %
		Y	2.64	67.77	16.01		150.0	
		Z	2.55	68.82	16.23		150.0	
10156-CAE	LTE-FDD (SC-FDMA, 50% RB, 5 MHz, QPSK)	X	1.90	69.38	15.98	0.00	150.0	± 9.6 %
		Y	1.87	68.22	15.49		150.0	
		Z	1.73	69.10	15.35		150.0	
10157-CAE	LTE-FDD (SC-FDMA, 50% RB, 5 MHz, 16-QAM)	X	2.13	67.61	14.49	0.00	150.0	± 9.6 %
		Y	2.14	66.94	14.37		150.0	
		Z	1.88	66.88	13.39		150.0	
10158-CAE	LTE-FDD (SC-FDMA, 50% RB, 10 MHz, 64-QAM)	X	2.80	68.62	16.48	0.00	150.0	± 9.6 %
		Y	2.80	67.95	16.18		150.0	
		Z	2.70	69.02	16.37		150.0	
10159-CAE	LTE-FDD (SC-FDMA, 50% RB, 5 MHz, 64-QAM)	X	2.24	68.05	14.76	0.00	150.0	± 9.6 %
		Y	2.25	67.38	14.65		150.0	
		Z	1.97	67.26	13.62		150.0	
10160-CAD	LTE-FDD (SC-FDMA, 50% RB, 15 MHz, QPSK)	X	2.79	68.96	16.56	0.00	150.0	± 9.6 %
		Y	2.78	68.29	16.16		150.0	
		Z	2.67	69.03	16.52		150.0	
10161-CAD	LTE-FDD (SC-FDMA, 50% RB, 15 MHz, 16-QAM)	X	2.95	67.54	16.03	0.00	150.0	± 9.6 %
		Y	2.97	67.10	15.79		150.0	
		Z	2.82	67.63	15.91		150.0	
10162-CAD	LTE-FDD (SC-FDMA, 50% RB, 15 MHz, 64-QAM)	X	3.06	67.69	16.14	0.00	150.0	± 9.6 %
		Y	3.08	67.22	15.89		150.0	
		Z	2.94	67.84	16.05		150.0	
10166-CAE	LTE-FDD (SC-FDMA, 50% RB, 1.4 MHz, QPSK)	X	3.60	69.71	19.22	3.01	150.0	± 9.6 %
		Y	3.76	69.53	19.10		150.0	
		Z	3.14	68.43	18.52		150.0	
10167-CAE	LTE-FDD (SC-FDMA, 50% RB, 1.4 MHz, 16-QAM)	X	4.49	72.92	19.79	3.01	150.0	± 9.6 %
		Y	4.71	72.48	19.58		150.0	
		Z	3.64	70.88	18.81		150.0	

10168-CAE	LTE-FDD (SC-FDMA, 50% RB, 1.4 MHz, 64-QAM)	X	4.99	75.19	21.10	3.01	150.0	± 9.6 %
		Y	5.19	74.57	20.82		150.0	
		Z	4.03	73.14	20.19		150.0	
10169-CAD	LTE-FDD (SC-FDMA, 1 RB, 20 MHz, QPSK)	X	3.02	69.31	19.06	3.01	150.0	± 9.6 %
		Y	3.27	69.70	19.15		150.0	
		Z	2.51	66.78	17.76		150.0	
10170-CAD	LTE-FDD (SC-FDMA, 1 RB, 20 MHz, 16-QAM)	X	4.24	75.66	21.52	3.01	150.0	± 9.6 %
		Y	4.60	75.59	21.37		150.0	
		Z	3.08	71.28	19.66		150.0	
10171-AAD	LTE-FDD (SC-FDMA, 1 RB, 20 MHz, 64-QAM)	X	3.48	71.52	18.79	3.01	150.0	± 9.6 %
		Y	3.80	71.54	18.73		150.0	
		Z	2.62	68.04	17.18		150.0	
10172-CAD	LTE-TDD (SC-FDMA, 1 RB, 20 MHz, QPSK)	X	9.86	97.03	31.31	6.02	65.0	± 9.6 %
		Y	11.94	97.60	31.03		65.0	
		Z	3.49	77.54	23.86		65.0	
10173-CAD	LTE-TDD (SC-FDMA, 1 RB, 20 MHz, 16-QAM)	X	35.90	116.24	34.55	6.02	65.0	± 9.6 %
		Y	33.36	111.72	33.12		65.0	
		Z	6.56	87.15	25.45		65.0	
10174-CAD	LTE-TDD (SC-FDMA, 1 RB, 20 MHz, 64-QAM)	X	21.48	105.16	30.85	6.02	65.0	± 9.6 %
		Y	20.65	101.59	29.68		65.0	
		Z	4.70	80.63	22.56		65.0	
10175-CAE	LTE-FDD (SC-FDMA, 1 RB, 10 MHz, QPSK)	X	2.98	69.02	18.83	3.01	150.0	± 9.6 %
		Y	3.23	69.39	18.90		150.0	
		Z	2.49	66.55	17.55		150.0	
10176-CAE	LTE-FDD (SC-FDMA, 1 RB, 10 MHz, 16-QAM)	X	4.24	75.68	21.53	3.01	150.0	± 9.6 %
		Y	4.61	75.61	21.38		150.0	
		Z	3.09	71.30	19.67		150.0	
10177-CAG	LTE-FDD (SC-FDMA, 1 RB, 5 MHz, QPSK)	X	3.01	69.16	18.92	3.01	150.0	± 9.6 %
		Y	3.26	69.54	19.00		150.0	
		Z	2.50	66.65	17.62		150.0	
10178-CAE	LTE-FDD (SC-FDMA, 1 RB, 5 MHz, 16-QAM)	X	4.21	75.48	21.42	3.01	150.0	± 9.6 %
		Y	4.56	75.38	21.26		150.0	
		Z	3.07	71.19	19.60		150.0	
10179-CAE	LTE-FDD (SC-FDMA, 1 RB, 10 MHz, 64-QAM)	X	3.83	73.49	20.03	3.01	150.0	± 9.6 %
		Y	4.16	73.42	19.91		150.0	
		Z	2.83	69.59	18.31		150.0	
10180-CAE	LTE-FDD (SC-FDMA, 1 RB, 5 MHz, 64-QAM)	X	3.47	71.46	18.75	3.01	150.0	± 9.6 %
		Y	3.79	71.47	18.68		150.0	
		Z	2.62	68.01	17.15		150.0	
10181-CAD	LTE-FDD (SC-FDMA, 1 RB, 15 MHz, QPSK)	X	3.00	69.14	18.91	3.01	150.0	± 9.6 %
		Y	3.26	69.52	18.99		150.0	
		Z	2.50	66.64	17.62		150.0	
10182-CAD	LTE-FDD (SC-FDMA, 1 RB, 15 MHz, 16-QAM)	X	4.20	75.46	21.41	3.01	150.0	± 9.6 %
		Y	4.55	75.36	21.25		150.0	
		Z	3.07	71.17	19.59		150.0	
10183-AAC	LTE-FDD (SC-FDMA, 1 RB, 15 MHz, 64-QAM)	X	3.46	71.44	18.74	3.01	150.0	± 9.6 %
		Y	3.78	71.45	18.67		150.0	
		Z	2.62	68.00	17.14		150.0	

10184-CAD	LTE-FDD (SC-FDMA, 1 RB, 3 MHz, QPSK)	X	3.01	69.18	18.93	3.01	150.0	± 9.6 %
		Y	3.27	69.56	19.01		150.0	
		Z	2.51	66.67	17.63		150.0	
10185-CAD	LTE-FDD (SC-FDMA, 1 RB, 3 MHz, 16-QAM)	X	4.22	75.53	21.45	3.01	150.0	± 9.6 %
		Y	4.57	75.42	21.28		150.0	
		Z	3.08	71.23	19.63		150.0	
10186-AAD	LTE-FDD (SC-FDMA, 1 RB, 3 MHz, 64-QAM)	X	3.48	71.51	18.77	3.01	150.0	± 9.6 %
		Y	3.80	71.51	18.70		150.0	
		Z	2.63	68.05	17.17		150.0	
10187-CAE	LTE-FDD (SC-FDMA, 1 RB, 1.4 MHz, QPSK)	X	3.02	69.24	19.00	3.01	150.0	± 9.6 %
		Y	3.28	69.61	19.07		150.0	
		Z	2.52	66.73	17.71		150.0	
10188-CAE	LTE-FDD (SC-FDMA, 1 RB, 1.4 MHz, 16-QAM)	X	4.35	76.17	21.80	3.01	150.0	± 9.6 %
		Y	4.72	76.08	21.65		150.0	
		Z	3.15	71.69	19.93		150.0	
10189-AAE	LTE-FDD (SC-FDMA, 1 RB, 1.4 MHz, 64-QAM)	X	3.56	71.93	19.04	3.01	150.0	± 9.6 %
		Y	3.88	71.93	18.97		150.0	
		Z	2.67	68.37	17.41		150.0	
10193-CAB	IEEE 802.11n (HT Greenfield, 6.5 Mbps, BPSK)	X	4.54	66.68	16.24	0.00	150.0	± 9.6 %
		Y	4.59	66.47	16.13		150.0	
		Z	4.40	66.85	16.19		150.0	
10194-CAB	IEEE 802.11n (HT Greenfield, 39 Mbps, 16-QAM)	X	4.70	66.99	16.36	0.00	150.0	± 9.6 %
		Y	4.77	66.80	16.26		150.0	
		Z	4.55	67.09	16.33		150.0	
10195-CAB	IEEE 802.11n (HT Greenfield, 65 Mbps, 64-QAM)	X	4.74	67.02	16.38	0.00	150.0	± 9.6 %
		Y	4.81	66.83	16.27		150.0	
		Z	4.58	67.11	16.34		150.0	
10196-CAB	IEEE 802.11n (HT Mixed, 6.5 Mbps, BPSK)	X	4.54	66.74	16.25	0.00	150.0	± 9.6 %
		Y	4.60	66.55	16.16		150.0	
		Z	4.39	66.85	16.19		150.0	
10197-CAB	IEEE 802.11n (HT Mixed, 39 Mbps, 16-QAM)	X	4.72	67.01	16.37	0.00	150.0	± 9.6 %
		Y	4.78	66.83	16.27		150.0	
		Z	4.56	67.10	16.33		150.0	
10198-CAB	IEEE 802.11n (HT Mixed, 65 Mbps, 64-QAM)	X	4.75	67.04	16.39	0.00	150.0	± 9.6 %
		Y	4.81	66.85	16.28		150.0	
		Z	4.58	67.11	16.34		150.0	
10219-CAB	IEEE 802.11n (HT Mixed, 7.2 Mbps, BPSK)	X	4.49	66.76	16.22	0.00	150.0	± 9.6 %
		Y	4.55	66.56	16.12		150.0	
		Z	4.34	66.89	16.16		150.0	
10220-CAB	IEEE 802.11n (HT Mixed, 43.3 Mbps, 16-QAM)	X	4.71	66.98	16.36	0.00	150.0	± 9.6 %
		Y	4.78	66.81	16.26		150.0	
		Z	4.55	67.06	16.32		150.0	
10221-CAB	IEEE 802.11n (HT Mixed, 72.2 Mbps, 64-QAM)	X	4.75	66.96	16.37	0.00	150.0	± 9.6 %
		Y	4.82	66.78	16.27		150.0	
		Z	4.59	67.05	16.33		150.0	
10222-CAB	IEEE 802.11n (HT Mixed, 15 Mbps, BPSK)	X	5.08	67.12	16.48	0.00	150.0	± 9.6 %
		Y	5.14	67.00	16.39		150.0	
		Z	4.96	67.13	16.45		150.0	

10223-CAB	IEEE 802.11n (HT Mixed, 90 Mbps, 16-QAM)	X	5.38	67.33	16.60	0.00	150.0	± 9.6 %
		Y	5.45	67.20	16.51		150.0	
		Z	5.23	67.33	16.56		150.0	
10224-CAB	IEEE 802.11n (HT Mixed, 150 Mbps, 64-QAM)	X	5.13	67.23	16.46	0.00	150.0	± 9.6 %
		Y	5.19	67.11	16.37		150.0	
		Z	4.99	67.25	16.44		150.0	
10225-CAB	UMTS-FDD (HSPA+)	X	2.82	66.29	15.44	0.00	150.0	± 9.6 %
		Y	2.85	65.89	15.31		150.0	
		Z	2.69	66.42	15.13		150.0	
10226-CAA	LTE-TDD (SC-FDMA, 1 RB, 1.4 MHz, 16-QAM)	X	40.58	118.73	35.31	6.02	65.0	± 9.6 %
		Y	36.88	113.76	33.77		65.0	
		Z	6.94	88.26	25.92		65.0	
10227-CAA	LTE-TDD (SC-FDMA, 1 RB, 1.4 MHz, 64-QAM)	X	36.33	114.29	33.35	6.02	65.0	± 9.6 %
		Y	31.30	108.87	31.78		65.0	
		Z	6.95	87.06	24.80		65.0	
10228-CAA	LTE-TDD (SC-FDMA, 1 RB, 1.4 MHz, QPSK)	X	13.65	104.05	33.59	6.02	65.0	± 9.6 %
		Y	18.81	107.23	34.08		65.0	
		Z	4.50	82.80	25.97		65.0	
10229-CAB	LTE-TDD (SC-FDMA, 1 RB, 3 MHz, 16-QAM)	X	36.18	116.36	34.59	6.02	65.0	± 9.6 %
		Y	33.58	111.82	33.15		65.0	
		Z	6.61	87.25	25.49		65.0	
10230-CAB	LTE-TDD (SC-FDMA, 1 RB, 3 MHz, 64-QAM)	X	32.38	112.10	32.69	6.02	65.0	± 9.6 %
		Y	28.70	107.19	31.24		65.0	
		Z	6.54	85.97	24.36		65.0	
10231-CAB	LTE-TDD (SC-FDMA, 1 RB, 3 MHz, QPSK)	X	12.84	102.68	33.09	6.02	65.0	± 9.6 %
		Y	17.62	105.78	33.56		65.0	
		Z	4.35	82.09	25.62		65.0	
10232-CAD	LTE-TDD (SC-FDMA, 1 RB, 5 MHz, 16-QAM)	X	36.15	116.36	34.59	6.02	65.0	± 9.6 %
		Y	33.55	111.82	33.15		65.0	
		Z	6.59	87.23	25.48		65.0	
10233-CAD	LTE-TDD (SC-FDMA, 1 RB, 5 MHz, 64-QAM)	X	32.28	112.07	32.68	6.02	65.0	± 9.6 %
		Y	28.65	107.18	31.24		65.0	
		Z	6.52	85.93	24.35		65.0	
10234-CAD	LTE-TDD (SC-FDMA, 1 RB, 5 MHz, QPSK)	X	12.22	101.47	32.58	6.02	65.0	± 9.6 %
		Y	16.65	104.42	33.04		65.0	
		Z	4.24	81.51	25.28		65.0	
10235-CAD	LTE-TDD (SC-FDMA, 1 RB, 10 MHz, 16-QAM)	X	36.31	116.46	34.62	6.02	65.0	± 9.6 %
		Y	33.66	111.90	33.18		65.0	
		Z	6.60	87.26	25.49		65.0	
10236-CAD	LTE-TDD (SC-FDMA, 1 RB, 10 MHz, 64-QAM)	X	33.06	112.44	32.77	6.02	65.0	± 9.6 %
		Y	29.12	107.43	31.30		65.0	
		Z	6.60	86.11	24.40		65.0	
10237-CAD	LTE-TDD (SC-FDMA, 1 RB, 10 MHz, QPSK)	X	12.90	102.82	33.13	6.02	65.0	± 9.6 %
		Y	17.72	105.93	33.61		65.0	
		Z	4.35	82.12	25.64		65.0	
10238-CAD	LTE-TDD (SC-FDMA, 1 RB, 15 MHz, 16-QAM)	X	36.09	116.34	34.59	6.02	65.0	± 9.6 %
		Y	33.52	111.82	33.15		65.0	
		Z	6.58	87.20	25.47		65.0	

10239-CAD	LTE-TDD (SC-FDMA, 1 RB, 15 MHz, 64-QAM)	X	32.17	112.03	32.67	6.02	65.0	± 9.6 %
		Y	28.59	107.16	31.23		65.0	
		Z	6.49	85.89	24.34		65.0	
10240-CAD	LTE-TDD (SC-FDMA, 1 RB, 15 MHz, QPSK)	X	12.85	102.75	33.11	6.02	65.0	± 9.6 %
		Y	17.65	105.86	33.59		65.0	
		Z	4.34	82.09	25.63		65.0	
10241-CAA	LTE-TDD (SC-FDMA, 50% RB, 1.4 MHz, 16-QAM)	X	8.52	83.40	26.72	6.98	65.0	± 9.6 %
		Y	9.34	83.46	26.63		65.0	
		Z	6.49	79.39	24.77		65.0	
10242-CAA	LTE-TDD (SC-FDMA, 50% RB, 1.4 MHz, 64-QAM)	X	7.72	81.29	25.79	6.98	65.0	± 9.6 %
		Y	8.22	80.66	25.42		65.0	
		Z	5.72	76.85	23.63		65.0	
10243-CAA	LTE-TDD (SC-FDMA, 50% RB, 1.4 MHz, QPSK)	X	5.95	76.72	24.82	6.98	65.0	± 9.6 %
		Y	6.41	76.67	24.65		65.0	
		Z	4.75	73.34	22.98		65.0	
10244-CAB	LTE-TDD (SC-FDMA, 50% RB, 3 MHz, 16-QAM)	X	6.67	78.45	19.67	3.98	65.0	± 9.6 %
		Y	8.20	80.91	21.14		65.0	
		Z	3.50	69.23	14.35		65.0	
10245-CAB	LTE-TDD (SC-FDMA, 50% RB, 3 MHz, 64-QAM)	X	6.39	77.48	19.23	3.98	65.0	± 9.6 %
		Y	7.92	80.07	20.76		65.0	
		Z	3.42	68.65	14.03		65.0	
10246-CAB	LTE-TDD (SC-FDMA, 50% RB, 3 MHz, QPSK)	X	8.15	85.97	22.95	3.98	65.0	± 9.6 %
		Y	9.24	86.80	23.49		65.0	
		Z	4.03	75.23	17.77		65.0	
10247-CAD	LTE-TDD (SC-FDMA, 50% RB, 5 MHz, 16-QAM)	X	5.50	76.42	20.00	3.98	65.0	± 9.6 %
		Y	6.26	77.49	20.66		65.0	
		Z	3.95	71.61	16.94		65.0	
10248-CAD	LTE-TDD (SC-FDMA, 50% RB, 5 MHz, 64-QAM)	X	5.40	75.54	19.60	3.98	65.0	± 9.6 %
		Y	6.16	76.66	20.28		65.0	
		Z	3.89	70.88	16.59		65.0	
10249-CAD	LTE-TDD (SC-FDMA, 50% RB, 5 MHz, QPSK)	X	9.66	89.43	25.19	3.98	65.0	± 9.6 %
		Y	10.35	89.11	25.13		65.0	
		Z	5.64	80.91	21.33		65.0	
10250-CAD	LTE-TDD (SC-FDMA, 50% RB, 10 MHz, 16-QAM)	X	6.21	78.20	22.44	3.98	65.0	± 9.6 %
		Y	6.93	79.00	22.73		65.0	
		Z	4.95	74.96	20.57		65.0	
10251-CAD	LTE-TDD (SC-FDMA, 50% RB, 10 MHz, 64-QAM)	X	5.85	75.76	21.03	3.98	65.0	± 9.6 %
		Y	6.49	76.44	21.31		65.0	
		Z	4.69	72.73	19.17		65.0	
10252-CAD	LTE-TDD (SC-FDMA, 50% RB, 10 MHz, QPSK)	X	8.41	86.24	25.10	3.98	65.0	± 9.6 %
		Y	9.13	86.11	24.91		65.0	
		Z	5.95	81.04	22.79		65.0	
10253-CAD	LTE-TDD (SC-FDMA, 50% RB, 15 MHz, 16-QAM)	X	5.81	74.45	20.83	3.98	65.0	± 9.6 %
		Y	6.39	75.11	21.05		65.0	
		Z	4.88	72.13	19.42		65.0	
10254-CAD	LTE-TDD (SC-FDMA, 50% RB, 15 MHz, 64-QAM)	X	6.16	75.32	21.51	3.98	65.0	± 9.6 %
		Y	6.77	75.99	21.73		65.0	
		Z	5.19	73.05	20.14		65.0	

10255-CAD	LTE-TDD (SC-FDMA, 50% RB, 15 MHz, QPSK)	X	6.96	80.42	23.12	3.98	65.0	± 9.6 %
		Y	7.59	80.64	23.06		65.0	
		Z	5.51	77.21	21.58		65.0	
10256-CAA	LTE-TDD (SC-FDMA, 100% RB, 1.4 MHz, 16-QAM)	X	4.89	73.41	16.49	3.98	65.0	± 9.6 %
		Y	6.68	77.30	18.76		65.0	
		Z	2.46	64.75	10.88		65.0	
10257-CAA	LTE-TDD (SC-FDMA, 100% RB, 1.4 MHz, 64-QAM)	X	4.63	72.26	15.89	3.98	65.0	± 9.6 %
		Y	6.35	76.13	18.19		65.0	
		Z	2.42	64.27	10.52		65.0	
10258-CAA	LTE-TDD (SC-FDMA, 100% RB, 1.4 MHz, QPSK)	X	5.50	79.01	19.45	3.98	65.0	± 9.6 %
		Y	7.01	81.77	20.90		65.0	
		Z	2.56	68.30	13.54		65.0	
10259-CAB	LTE-TDD (SC-FDMA, 100% RB, 3 MHz, 16-QAM)	X	5.80	77.14	20.90	3.98	65.0	± 9.6 %
		Y	6.53	78.01	21.38		65.0	
		Z	4.38	73.08	18.36		65.0	
10260-CAB	LTE-TDD (SC-FDMA, 100% RB, 3 MHz, 64-QAM)	X	5.78	76.67	20.70	3.98	65.0	± 9.6 %
		Y	6.51	77.60	21.22		65.0	
		Z	4.39	72.73	18.19		65.0	
10261-CAB	LTE-TDD (SC-FDMA, 100% RB, 3 MHz, QPSK)	X	8.27	86.47	24.62	3.98	65.0	± 9.6 %
		Y	9.00	86.40	24.57		65.0	
		Z	5.46	80.05	21.57		65.0	
10262-CAD	LTE-TDD (SC-FDMA, 100% RB, 5 MHz, 16-QAM)	X	6.19	78.15	22.39	3.98	65.0	± 9.6 %
		Y	6.92	78.95	22.69		65.0	
		Z	4.94	74.88	20.51		65.0	
10263-CAD	LTE-TDD (SC-FDMA, 100% RB, 5 MHz, 64-QAM)	X	5.84	75.72	21.02	3.98	65.0	± 9.6 %
		Y	6.48	76.42	21.31		65.0	
		Z	4.68	72.71	19.16		65.0	
10264-CAD	LTE-TDD (SC-FDMA, 100% RB, 5 MHz, QPSK)	X	8.30	85.98	24.99	3.98	65.0	± 9.6 %
		Y	9.03	85.88	24.80		65.0	
		Z	5.88	80.81	22.67		65.0	
10265-CAD	LTE-TDD (SC-FDMA, 100% RB, 10 MHz, 16-QAM)	X	5.96	75.09	21.13	3.98	65.0	± 9.6 %
		Y	6.59	75.82	21.35		65.0	
		Z	4.95	72.53	19.70		65.0	
10266-CAD	LTE-TDD (SC-FDMA, 100% RB, 10 MHz, 64-QAM)	X	6.33	75.99	21.86	3.98	65.0	± 9.6 %
		Y	6.97	76.70	22.07		65.0	
		Z	5.31	73.56	20.51		65.0	
10267-CAD	LTE-TDD (SC-FDMA, 100% RB, 10 MHz, QPSK)	X	7.45	81.44	23.28	3.98	65.0	± 9.6 %
		Y	8.11	81.58	23.17		65.0	
		Z	5.81	77.97	21.72		65.0	
10268-CAD	LTE-TDD (SC-FDMA, 100% RB, 15 MHz, 16-QAM)	X	6.50	74.59	21.27	3.98	65.0	± 9.6 %
		Y	7.11	75.29	21.47		65.0	
		Z	5.58	72.49	20.14		65.0	
10269-CAD	LTE-TDD (SC-FDMA, 100% RB, 15 MHz, 64-QAM)	X	6.45	74.07	21.10	3.98	65.0	± 9.6 %
		Y	7.04	74.76	21.30		65.0	
		Z	5.59	72.11	20.01		65.0	
10270-CAD	LTE-TDD (SC-FDMA, 100% RB, 15 MHz, QPSK)	X	6.83	77.38	21.77	3.98	65.0	± 9.6 %
		Y	7.44	77.78	21.79		65.0	
		Z	5.71	75.01	20.64		65.0	

10274-CAB	UMTS-FDD (HSUPA, Subtest 5, 3GPP Rel8.10)	X	2.62	66.75	15.42	0.00	150.0	± 9.6 %
		Y	2.61	66.15	15.17		150.0	
		Z	2.54	67.07	15.23		150.0	
10275-CAB	UMTS-FDD (HSUPA, Subtest 5, 3GPP Rel8.4)	X	1.67	68.55	15.99	0.00	150.0	± 9.6 %
		Y	1.61	67.31	15.31		150.0	
		Z	1.61	68.63	15.84		150.0	
10277-CAA	PHS (QPSK)	X	1.74	60.91	6.37	9.03	50.0	± 9.6 %
		Y	2.31	62.75	8.24		50.0	
		Z	1.34	59.32	4.61		50.0	
10278-CAA	PHS (QPSK, BW 884MHz, Rolloff 0.5)	X	9.23	83.71	19.86	9.03	50.0	± 9.6 %
		Y	16.13	92.59	23.80		50.0	
		Z	2.80	66.68	11.50		50.0	
10279-CAA	PHS (QPSK, BW 884MHz, Rolloff 0.38)	X	9.55	84.14	20.09	9.03	50.0	± 9.6 %
		Y	16.22	92.62	23.87		50.0	
		Z	2.90	67.01	11.74		50.0	
10290-AAB	CDMA2000, RC1, SO55, Full Rate	X	1.55	69.78	14.51	0.00	150.0	± 9.6 %
		Y	1.48	68.23	14.09		150.0	
		Z	1.19	67.52	12.47		150.0	
10291-AAB	CDMA2000, RC3, SO55, Full Rate	X	0.89	66.83	13.08	0.00	150.0	± 9.6 %
		Y	0.85	65.35	12.57		150.0	
		Z	0.74	65.55	11.46		150.0	
10292-AAB	CDMA2000, RC3, SO32, Full Rate	X	1.27	72.61	16.13	0.00	150.0	± 9.6 %
		Y	1.03	68.80	14.67		150.0	
		Z	1.20	72.32	14.93		150.0	
10293-AAB	CDMA2000, RC3, SO3, Full Rate	X	2.34	81.60	20.09	0.00	150.0	± 9.6 %
		Y	1.43	73.64	17.27		150.0	
		Z	3.93	87.90	20.92		150.0	
10295-AAB	CDMA2000, RC1, SO3, 1/8th Rate 25 fr.	X	16.32	98.49	29.02	9.03	50.0	± 9.6 %
		Y	11.98	92.39	27.58		50.0	
		Z	18.77	96.90	26.52		50.0	
10297-AAC	LTE-FDD (SC-FDMA, 50% RB, 20 MHz, QPSK)	X	2.80	70.02	16.88	0.00	150.0	± 9.6 %
		Y	2.77	69.27	16.41		150.0	
		Z	2.65	69.87	16.82		150.0	
10298-AAC	LTE-FDD (SC-FDMA, 50% RB, 3 MHz, QPSK)	X	1.62	68.28	14.44	0.00	150.0	± 9.6 %
		Y	1.62	67.40	14.26		150.0	
		Z	1.32	66.56	12.71		150.0	
10299-AAC	LTE-FDD (SC-FDMA, 50% RB, 3 MHz, 16-QAM)	X	2.59	69.34	14.00	0.00	150.0	± 9.6 %
		Y	2.92	70.30	15.01		150.0	
		Z	1.54	64.05	10.22		150.0	
10300-AAC	LTE-FDD (SC-FDMA, 50% RB, 3 MHz, 64-QAM)	X	1.92	64.86	11.14	0.00	150.0	± 9.6 %
		Y	2.24	65.95	12.27		150.0	
		Z	1.26	61.60	8.20		150.0	
10301-AAA	IEEE 802.16e WiMAX (29:18, 5ms, 10MHz, QPSK, PUSC)	X	4.85	66.06	17.86	4.17	50.0	± 9.6 %
		Y	4.97	65.84	17.76		50.0	
		Z	4.42	65.27	17.23		50.0	
10302-AAA	IEEE 802.16e WiMAX (29:18, 5ms, 10MHz, QPSK, PUSC, 3 CTRL symbols)	X	5.22	66.19	18.31	4.96	50.0	± 9.6 %
		Y	5.38	66.17	18.31		50.0	
		Z	4.86	65.76	17.88		50.0	

10303-AAA	IEEE 802.16e WiMAX (31:15, 5ms, 10MHz, 64QAM, PUSC)	X	4.96	65.79	18.13	4.96	50.0	± 9.6 %
		Y	5.14	65.84	18.17		50.0	
		Z	4.61	65.34	17.65		50.0	
10304-AAA	IEEE 802.16e WiMAX (29:18, 5ms, 10MHz, 64QAM, PUSC)	X	4.78	65.69	17.62	4.17	50.0	± 9.6 %
		Y	4.94	65.66	17.62		50.0	
		Z	4.45	65.35	17.22		50.0	
10305-AAA	IEEE 802.16e WiMAX (31:15, 10ms, 10MHz, 64QAM, PUSC, 15 symbols)	X	4.24	66.91	19.40	6.02	35.0	± 9.6 %
		Y	4.54	67.57	19.86		35.0	
		Z	3.84	65.89	18.29		35.0	
10306-AAA	IEEE 802.16e WiMAX (29:18, 10ms, 10MHz, 64QAM, PUSC, 18 symbols)	X	4.62	66.22	19.11	6.02	35.0	± 9.6 %
		Y	4.86	66.59	19.39		35.0	
		Z	4.26	65.53	18.31		35.0	
10307-AAA	IEEE 802.16e WiMAX (29:18, 10ms, 10MHz, QPSK, PUSC, 18 symbols)	X	4.50	66.31	19.05	6.02	35.0	± 9.6 %
		Y	4.77	66.81	19.39		35.0	
		Z	4.12	65.47	18.17		35.0	
10308-AAA	IEEE 802.16e WiMAX (29:18, 10ms, 10MHz, 16QAM, PUSC)	X	4.47	66.49	19.18	6.02	35.0	± 9.6 %
		Y	4.73	66.98	19.51		35.0	
		Z	4.09	65.63	18.30		35.0	
10309-AAA	IEEE 802.16e WiMAX (29:18, 10ms, 10MHz, 16QAM, AMC 2x3, 18 symbols)	X	4.68	66.45	19.27	6.02	35.0	± 9.6 %
		Y	4.93	66.86	19.56		35.0	
		Z	4.28	65.63	18.41		35.0	
10310-AAA	IEEE 802.16e WiMAX (29:18, 10ms, 10MHz, QPSK, AMC 2x3, 18 symbols)	X	4.56	66.25	19.08	6.02	35.0	± 9.6 %
		Y	4.81	66.65	19.36		35.0	
		Z	4.20	65.54	18.28		35.0	
10311-AAC	LTE-FDD (SC-FDMA, 100% RB, 15 MHz, QPSK)	X	3.16	69.26	16.50	0.00	150.0	± 9.6 %
		Y	3.13	68.60	16.08		150.0	
		Z	3.01	69.09	16.45		150.0	
10313-AAA	IDEN 1:3	X	8.00	86.23	21.34	6.99	70.0	± 9.6 %
		Y	8.53	85.21	20.95		70.0	
		Z	3.31	75.28	17.31		70.0	
10314-AAA	IDEN 1:6	X	12.68	100.31	29.33	10.00	30.0	± 9.6 %
		Y	13.31	98.73	28.67		30.0	
		Z	5.19	85.23	24.17		30.0	
10315-AAB	IEEE 802.11b WiFi 2.4 GHz (DSSS, 1 Mbps, 96pc duty cycle)	X	1.10	64.07	15.53	0.17	150.0	± 9.6 %
		Y	1.10	63.56	15.08		150.0	
		Z	1.08	63.95	15.31		150.0	
10316-AAB	IEEE 802.11g WiFi 2.4 GHz (ERP-OFDM, 6 Mbps, 96pc duty cycle)	X	4.59	66.75	16.41	0.17	150.0	± 9.6 %
		Y	4.66	66.58	16.32		150.0	
		Z	4.43	66.78	16.29		150.0	
10317-AAB	IEEE 802.11a WiFi 5 GHz (OFDM, 6 Mbps, 96pc duty cycle)	X	4.59	66.75	16.41	0.17	150.0	± 9.6 %
		Y	4.66	66.58	16.32		150.0	
		Z	4.43	66.78	16.29		150.0	
10400-AAC	IEEE 802.11ac WiFi (20MHz, 64-QAM, 99pc duty cycle)	X	4.69	67.06	16.37	0.00	150.0	± 9.6 %
		Y	4.77	66.86	16.25		150.0	
		Z	4.51	67.11	16.31		150.0	
10401-AAC	IEEE 802.11ac WiFi (40MHz, 64-QAM, 99pc duty cycle)	X	5.41	67.26	16.54	0.00	150.0	± 9.6 %
		Y	5.45	67.06	16.42		150.0	
		Z	5.18	66.94	16.33		150.0	

10402-AAC	IEEE 802.11ac WiFi (80MHz, 64-QAM, 99pc duty cycle)	X	5.65	67.49	16.51	0.00	150.0	± 9.6 %
		Y	5.72	67.43	16.45		150.0	
		Z	5.51	67.47	16.48		150.0	
10403-AAB	CDMA2000 (1xEV-DO, Rev. 0)	X	1.55	69.78	14.51	0.00	115.0	± 9.6 %
		Y	1.48	68.23	14.09		115.0	
		Z	1.19	67.52	12.47		115.0	
10404-AAB	CDMA2000 (1xEV-DO, Rev. A)	X	1.55	69.78	14.51	0.00	115.0	± 9.6 %
		Y	1.48	68.23	14.09		115.0	
		Z	1.19	67.52	12.47		115.0	
10406-AAB	CDMA2000, RC3, SO32, SCH0, Full Rate	X	100.00	120.41	29.76	0.00	100.0	± 9.6 %
		Y	19.72	99.25	25.38		100.0	
		Z	22.86	100.95	24.14		100.0	
10410-AAC	LTE-TDD (SC-FDMA, 1 RB, 10 MHz, QPSK, UL Subframe=2,3,4,7,8,9)	X	100.00	125.71	31.88	3.23	80.0	± 9.6 %
		Y	100.00	124.16	31.78		80.0	
		Z	8.15	91.76	22.46		80.0	
10415-AAA	IEEE 802.11b WiFi 2.4 GHz (DSSS, 1 Mbps, 99pc duty cycle)	X	1.03	63.26	14.92	0.00	150.0	± 9.6 %
		Y	1.02	62.63	14.41		150.0	
		Z	1.03	63.39	14.88		150.0	
10416-AAA	IEEE 802.11g WiFi 2.4 GHz (ERP-OFDM, 6 Mbps, 99pc duty cycle)	X	4.54	66.72	16.31	0.00	150.0	± 9.6 %
		Y	4.59	66.51	16.19		150.0	
		Z	4.40	66.84	16.26		150.0	
10417-AAA	IEEE 802.11a/h WiFi 5 GHz (OFDM, 6 Mbps, 99pc duty cycle)	X	4.54	66.72	16.31	0.00	150.0	± 9.6 %
		Y	4.59	66.51	16.19		150.0	
		Z	4.40	66.84	16.26		150.0	
10418-AAA	IEEE 802.11g WiFi 2.4 GHz (DSSS-OFDM, 6 Mbps, 99pc duty cycle, Long preamble)	X	4.53	66.89	16.33	0.00	150.0	± 9.6 %
		Y	4.58	66.66	16.20		150.0	
		Z	4.40	67.05	16.32		150.0	
10419-AAA	IEEE 802.11g WiFi 2.4 GHz (DSSS-OFDM, 6 Mbps, 99pc duty cycle, Short preamble)	X	4.55	66.83	16.33	0.00	150.0	± 9.6 %
		Y	4.60	66.61	16.21		150.0	
		Z	4.41	66.98	16.30		150.0	
10422-AAA	IEEE 802.11n (HT Greenfield, 7.2 Mbps, BPSK)	X	4.66	66.83	16.34	0.00	150.0	± 9.6 %
		Y	4.72	66.62	16.23		150.0	
		Z	4.52	66.95	16.31		150.0	
10423-AAA	IEEE 802.11n (HT Greenfield, 43.3 Mbps, 16-QAM)	X	4.82	67.13	16.45	0.00	150.0	± 9.6 %
		Y	4.90	66.96	16.35		150.0	
		Z	4.65	67.21	16.40		150.0	
10424-AAA	IEEE 802.11n (HT Greenfield, 72.2 Mbps, 64-QAM)	X	4.75	67.09	16.43	0.00	150.0	± 9.6 %
		Y	4.82	66.90	16.32		150.0	
		Z	4.58	67.17	16.38		150.0	
10425-AAA	IEEE 802.11n (HT Greenfield, 15 Mbps, BPSK)	X	5.35	67.37	16.60	0.00	150.0	± 9.6 %
		Y	5.42	67.27	16.52		150.0	
		Z	5.19	67.35	16.55		150.0	
10426-AAA	IEEE 802.11n (HT Greenfield, 90 Mbps, 16-QAM)	X	5.36	67.42	16.62	0.00	150.0	± 9.6 %
		Y	5.42	67.27	16.52		150.0	
		Z	5.21	67.42	16.58		150.0	

10427-AAA	IEEE 802.11n (HT Greenfield, 150 Mbps, 64-QAM)	X	5.37	67.38	16.60	0.00	150.0	± 9.6 %
		Y	5.43	67.25	16.50		150.0	
		Z	5.18	67.23	16.48		150.0	
10430-AAB	LTE-FDD (OFDMA, 5 MHz, E-TM 3.1)	X	4.24	70.83	18.17	0.00	150.0	± 9.6 %
		Y	4.26	70.25	18.02		150.0	
		Z	4.20	71.89	18.27		150.0	
10431-AAB	LTE-FDD (OFDMA, 10 MHz, E-TM 3.1)	X	4.21	67.30	16.30	0.00	150.0	± 9.6 %
		Y	4.28	67.03	16.19		150.0	
		Z	4.03	67.45	16.18		150.0	
10432-AAB	LTE-FDD (OFDMA, 15 MHz, E-TM 3.1)	X	4.51	67.15	16.38	0.00	150.0	± 9.6 %
		Y	4.58	66.93	16.27		150.0	
		Z	4.34	67.27	16.32		150.0	
10433-AAB	LTE-FDD (OFDMA, 20 MHz, E-TM 3.1)	X	4.76	67.12	16.45	0.00	150.0	± 9.6 %
		Y	4.83	66.94	16.34		150.0	
		Z	4.59	67.20	16.40		150.0	
10434-AAA	W-CDMA (BS Test Model 1, 64 DPCH)	X	4.34	71.72	18.14	0.00	150.0	± 9.6 %
		Y	4.35	71.03	17.99		150.0	
		Z	4.31	72.81	18.12		150.0	
10435-AAC	LTE-TDD (SC-FDMA, 1 RB, 20 MHz, QPSK, UL Subframe=2,3,4,7,8,9)	X	100.00	125.48	31.77	3.23	80.0	± 9.6 %
		Y	100.00	123.97	31.69		80.0	
		Z	7.63	90.76	22.11		80.0	
10447-AAB	LTE-FDD (OFDMA, 5 MHz, E-TM 3.1, Clipping 44%)	X	3.51	67.35	15.60	0.00	150.0	± 9.6 %
		Y	3.58	66.99	15.55		150.0	
		Z	3.28	67.36	15.16		150.0	
10448-AAB	LTE-FDD (OFDMA, 10 MHz, E-TM 3.1, Clipping 44%)	X	4.06	67.09	16.17	0.00	150.0	± 9.6 %
		Y	4.12	66.80	16.05		150.0	
		Z	3.89	67.25	16.05		150.0	
10449-AAB	LTE-FDD (OFDMA, 15 MHz, E-TM 3.1, Clipping 44%)	X	4.33	66.98	16.28	0.00	150.0	± 9.6 %
		Y	4.39	66.75	16.16		150.0	
		Z	4.18	67.10	16.22		150.0	
10450-AAB	LTE-FDD (OFDMA, 20 MHz, E-TM 3.1, Clipping 44%)	X	4.53	66.89	16.30	0.00	150.0	± 9.6 %
		Y	4.58	66.69	16.19		150.0	
		Z	4.39	66.98	16.26		150.0	
10451-AAA	W-CDMA (BS Test Model 1, 64 DPCH, Clipping 44%)	X	3.39	67.51	15.20	0.00	150.0	± 9.6 %
		Y	3.48	67.19	15.21		150.0	
		Z	3.10	67.22	14.48		150.0	
10456-AAA	IEEE 802.11ac WiFi (160MHz, 64-QAM, 99pc duty cycle)	X	6.22	67.91	16.74	0.00	150.0	± 9.6 %
		Y	6.28	67.83	16.68		150.0	
		Z	6.11	67.90	16.72		150.0	
10457-AAA	UMTS-FDD (DC-HSDPA)	X	3.80	65.37	16.02	0.00	150.0	± 9.6 %
		Y	3.83	65.15	15.90		150.0	
		Z	3.74	65.57	15.99		150.0	
10458-AAA	CDMA2000 (1xEV-DO, Rev. B, 2 carriers)	X	3.21	66.83	14.57	0.00	150.0	± 9.6 %
		Y	3.31	66.55	14.68		150.0	
		Z	2.82	66.01	13.39		150.0	
10459-AAA	CDMA2000 (1xEV-DO, Rev. B, 3 carriers)	X	4.29	65.14	15.57	0.00	150.0	± 9.6 %
		Y	4.36	64.71	15.51		150.0	
		Z	4.04	65.27	15.07		150.0	

10460-AAA	UMTS-FDD (WCDMA, AMR)	X	0.96	69.26	16.86	0.00	150.0	± 9.6 %
		Y	0.88	67.02	15.53		150.0	
		Z	0.94	69.35	16.76		150.0	
10461-AAA	LTE-TDD (SC-FDMA, 1 RB, 1.4 MHz, QPSK, UL Subframe=2,3,4,7,8,9)	X	100.00	131.25	34.47	3.29	80.0	± 9.6 %
		Y	100.00	128.59	33.89		80.0	
		Z	3.16	81.29	20.28		80.0	
10462-AAA	LTE-TDD (SC-FDMA, 1 RB, 1.4 MHz, 16-QAM, UL Subframe=2,3,4,7,8,9)	X	18.15	90.54	19.55	3.23	80.0	± 9.6 %
		Y	100.00	110.06	25.23		80.0	
		Z	0.71	60.00	7.72		80.0	
10463-AAA	LTE-TDD (SC-FDMA, 1 RB, 1.4 MHz, 64-QAM, UL Subframe=2,3,4,7,8,9)	X	2.32	68.92	12.27	3.23	80.0	± 9.6 %
		Y	12.78	85.50	18.46		80.0	
		Z	0.72	60.00	7.06		80.0	
10464-AAA	LTE-TDD (SC-FDMA, 1 RB, 3 MHz, QPSK, UL Subframe=2,3,4,7,8,9)	X	100.00	128.50	33.02	3.23	80.0	± 9.6 %
		Y	100.00	126.31	32.66		80.0	
		Z	2.43	77.27	18.20		80.0	
10465-AAA	LTE-TDD (SC-FDMA, 1 RB, 3 MHz, 16-QAM, UL Subframe=2,3,4,7,8,9)	X	7.48	81.44	16.98	3.23	80.0	± 9.6 %
		Y	53.06	102.63	23.42		80.0	
		Z	0.71	60.00	7.65		80.0	
10466-AAA	LTE-TDD (SC-FDMA, 1 RB, 3 MHz, 64-QAM, UL Subframe=2,3,4,7,8,9)	X	1.86	66.75	11.37	3.23	80.0	± 9.6 %
		Y	7.10	79.26	16.56		80.0	
		Z	0.72	60.00	7.01		80.0	
10467-AAC	LTE-TDD (SC-FDMA, 1 RB, 5 MHz, QPSK, UL Subframe=2,3,4,7,8,9)	X	100.00	128.82	33.16	3.23	80.0	± 9.6 %
		Y	100.00	126.57	32.78		80.0	
		Z	2.60	78.29	18.60		80.0	
10468-AAC	LTE-TDD (SC-FDMA, 1 RB, 5 MHz, 16-QAM, UL Subframe=2,3,4,7,8,9)	X	9.21	83.60	17.62	3.23	80.0	± 9.6 %
		Y	76.07	106.68	24.37		80.0	
		Z	0.70	60.00	7.67		80.0	
10469-AAC	LTE-TDD (SC-FDMA, 1 RB, 5 MHz, 64-QAM, UL Subframe=2,3,4,7,8,9)	X	1.87	66.82	11.40	3.23	80.0	± 9.6 %
		Y	7.22	79.45	16.62		80.0	
		Z	0.72	60.00	7.01		80.0	
10470-AAC	LTE-TDD (SC-FDMA, 1 RB, 10 MHz, QPSK, UL Subframe=2,3,4,7,8,9)	X	100.00	128.87	33.17	3.23	80.0	± 9.6 %
		Y	100.00	126.61	32.79		80.0	
		Z	2.61	78.33	18.61		80.0	
10471-AAC	LTE-TDD (SC-FDMA, 1 RB, 10 MHz, 16-QAM, UL Subframe=2,3,4,7,8,9)	X	9.03	83.37	17.54	3.23	80.0	± 9.6 %
		Y	75.72	106.57	24.32		80.0	
		Z	0.70	60.00	7.66		80.0	
10472-AAC	LTE-TDD (SC-FDMA, 1 RB, 10 MHz, 64-QAM, UL Subframe=2,3,4,7,8,9)	X	1.85	66.72	11.34	3.23	80.0	± 9.6 %
		Y	7.17	79.36	16.58		80.0	
		Z	0.72	60.00	6.99		80.0	
10473-AAC	LTE-TDD (SC-FDMA, 1 RB, 15 MHz, QPSK, UL Subframe=2,3,4,7,8,9)	X	100.00	128.83	33.15	3.23	80.0	± 9.6 %
		Y	100.00	126.57	32.77		80.0	
		Z	2.60	78.28	18.59		80.0	
10474-AAC	LTE-TDD (SC-FDMA, 1 RB, 15 MHz, 16-QAM, UL Subframe=2,3,4,7,8,9)	X	8.86	83.19	17.49	3.23	80.0	± 9.6 %
		Y	73.20	106.22	24.25		80.0	
		Z	0.70	60.00	7.66		80.0	
10475-AAC	LTE-TDD (SC-FDMA, 1 RB, 15 MHz, 64-QAM, UL Subframe=2,3,4,7,8,9)	X	1.84	66.67	11.33	3.23	80.0	± 9.6 %
		Y	7.07	79.22	16.54		80.0	
		Z	0.72	60.00	6.99		80.0	

10477-AAC	LTE-TDD (SC-FDMA, 1 RB, 20 MHz, 16-QAM, UL Subframe=2,3,4,7,8,9)	X	7.55	81.52	16.98	3.23	80.0	± 9.6 %
		Y	56.45	103.26	23.54		80.0	
		Z	0.70	60.00	7.63		80.0	
10478-AAC	LTE-TDD (SC-FDMA, 1 RB, 20 MHz, 64-QAM, UL Subframe=2,3,4,7,8,9)	X	1.82	66.56	11.27	3.23	80.0	± 9.6 %
		Y	6.95	79.03	16.47		80.0	
		Z	0.72	60.00	6.98		80.0	
10479-AAA	LTE-TDD (SC-FDMA, 50% RB, 1.4 MHz, QPSK, UL Subframe=2,3,4,7,8,9)	X	10.99	93.23	25.61	3.23	80.0	± 9.6 %
		Y	9.79	90.18	24.96		80.0	
		Z	4.54	80.48	20.41		80.0	
10480-AAA	LTE-TDD (SC-FDMA, 50% RB, 1.4 MHz, 16-QAM, UL Subframe=2,3,4,7,8,9)	X	12.16	88.23	21.88	3.23	80.0	± 9.6 %
		Y	11.98	87.55	22.28		80.0	
		Z	2.88	70.37	14.48		80.0	
10481-AAA	LTE-TDD (SC-FDMA, 50% RB, 1.4 MHz, 64-QAM, UL Subframe=2,3,4,7,8,9)	X	8.71	82.91	19.80	3.23	80.0	± 9.6 %
		Y	9.82	84.02	20.80		80.0	
		Z	2.18	66.77	12.57		80.0	
10482-AAA	LTE-TDD (SC-FDMA, 50% RB, 3 MHz, QPSK, UL Subframe=2,3,4,7,8,9)	X	4.05	77.33	19.19	2.23	80.0	± 9.6 %
		Y	4.17	76.68	19.19		80.0	
		Z	2.07	68.66	14.58		80.0	
10483-AAA	LTE-TDD (SC-FDMA, 50% RB, 3 MHz, 16-QAM, UL Subframe=2,3,4,7,8,9)	X	4.93	75.57	17.70	2.23	80.0	± 9.6 %
		Y	6.34	78.50	19.36		80.0	
		Z	1.80	63.38	11.04		80.0	
10484-AAA	LTE-TDD (SC-FDMA, 50% RB, 3 MHz, 64-QAM, UL Subframe=2,3,4,7,8,9)	X	4.47	74.01	17.11	2.23	80.0	± 9.6 %
		Y	5.79	76.98	18.82		80.0	
		Z	1.76	62.89	10.79		80.0	
10485-AAC	LTE-TDD (SC-FDMA, 50% RB, 5 MHz, QPSK, UL Subframe=2,3,4,7,8,9)	X	4.05	77.49	20.34	2.23	80.0	± 9.6 %
		Y	4.20	76.76	20.09		80.0	
		Z	2.71	72.24	17.50		80.0	
10486-AAC	LTE-TDD (SC-FDMA, 50% RB, 5 MHz, 16-QAM, UL Subframe=2,3,4,7,8,9)	X	3.54	71.63	17.34	2.23	80.0	± 9.6 %
		Y	3.76	71.58	17.54		80.0	
		Z	2.51	67.51	14.60		80.0	
10487-AAC	LTE-TDD (SC-FDMA, 50% RB, 5 MHz, 64-QAM, UL Subframe=2,3,4,7,8,9)	X	3.49	71.03	17.07	2.23	80.0	± 9.6 %
		Y	3.74	71.08	17.31		80.0	
		Z	2.49	67.04	14.35		80.0	
10488-AAC	LTE-TDD (SC-FDMA, 50% RB, 10 MHz, QPSK, UL Subframe=2,3,4,7,8,9)	X	3.92	74.84	20.03	2.23	80.0	± 9.6 %
		Y	4.21	74.77	19.87		80.0	
		Z	2.99	71.49	18.31		80.0	
10489-AAC	LTE-TDD (SC-FDMA, 50% RB, 10 MHz, 16-QAM, UL Subframe=2,3,4,7,8,9)	X	3.58	70.14	18.01	2.23	80.0	± 9.6 %
		Y	3.82	70.22	18.04		80.0	
		Z	3.03	68.36	16.75		80.0	
10490-AAC	LTE-TDD (SC-FDMA, 50% RB, 10 MHz, 64-QAM, UL Subframe=2,3,4,7,8,9)	X	3.66	69.89	17.90	2.23	80.0	± 9.6 %
		Y	3.90	69.97	17.95		80.0	
		Z	3.10	68.21	16.67		80.0	
10491-AAC	LTE-TDD (SC-FDMA, 50% RB, 15 MHz, QPSK, UL Subframe=2,3,4,7,8,9)	X	4.00	72.50	19.16	2.23	80.0	± 9.6 %
		Y	4.28	72.62	19.08		80.0	
		Z	3.25	70.05	17.90		80.0	
10492-AAC	LTE-TDD (SC-FDMA, 50% RB, 15 MHz, 16-QAM, UL Subframe=2,3,4,7,8,9)	X	3.86	68.99	17.79	2.23	80.0	± 9.6 %
		Y	4.11	69.18	17.85		80.0	
		Z	3.37	67.61	16.86		80.0	

10493-AAC	LTE-TDD (SC-FDMA, 50% RB, 15 MHz, 64-QAM, UL Subframe=2,3,4,7,8,9)	X	3.92	68.82	17.72	2.23	80.0	± 9.6 %
		Y	4.17	69.02	17.78		80.0	
		Z	3.43	67.50	16.80		80.0	
10494-AAC	LTE-TDD (SC-FDMA, 50% RB, 20 MHz, QPSK, UL Subframe=2,3,4,7,8,9)	X	4.43	74.41	19.78	2.23	80.0	± 9.6 %
		Y	4.75	74.52	19.68		80.0	
		Z	3.49	71.39	18.37		80.0	
10495-AAC	LTE-TDD (SC-FDMA, 50% RB, 20 MHz, 16-QAM, UL Subframe=2,3,4,7,8,9)	X	3.90	69.39	18.01	2.23	80.0	± 9.6 %
		Y	4.16	69.65	18.06		80.0	
		Z	3.39	67.86	17.06		80.0	
10496-AAC	LTE-TDD (SC-FDMA, 50% RB, 20 MHz, 64-QAM, UL Subframe=2,3,4,7,8,9)	X	3.97	69.05	17.88	2.23	80.0	± 9.6 %
		Y	4.22	69.30	17.94		80.0	
		Z	3.47	67.65	16.99		80.0	
10497-AAA	LTE-TDD (SC-FDMA, 100% RB, 1.4 MHz, QPSK, UL Subframe=2,3,4,7,8,9)	X	2.87	72.14	16.05	2.23	80.0	± 9.6 %
		Y	3.23	72.92	16.83		80.0	
		Z	1.19	62.14	10.12		80.0	
10498-AAA	LTE-TDD (SC-FDMA, 100% RB, 1.4 MHz, 16-QAM, UL Subframe=2,3,4,7,8,9)	X	1.73	63.11	10.85	2.23	80.0	± 9.6 %
		Y	2.27	65.45	12.56		80.0	
		Z	1.15	60.00	7.68		80.0	
10499-AAA	LTE-TDD (SC-FDMA, 100% RB, 1.4 MHz, 64-QAM, UL Subframe=2,3,4,7,8,9)	X	1.65	62.30	10.28	2.23	80.0	± 9.6 %
		Y	2.18	64.69	12.05		80.0	
		Z	1.17	60.00	7.51		80.0	
10500-AAA	LTE-TDD (SC-FDMA, 100% RB, 3 MHz, QPSK, UL Subframe=2,3,4,7,8,9)	X	3.87	75.87	20.03	2.23	80.0	± 9.6 %
		Y	4.07	75.40	19.81		80.0	
		Z	2.80	71.83	17.80		80.0	
10501-AAA	LTE-TDD (SC-FDMA, 100% RB, 3 MHz, 16-QAM, UL Subframe=2,3,4,7,8,9)	X	3.57	71.05	17.60	2.23	80.0	± 9.6 %
		Y	3.78	70.97	17.70		80.0	
		Z	2.79	68.23	15.59		80.0	
10502-AAA	LTE-TDD (SC-FDMA, 100% RB, 3 MHz, 64-QAM, UL Subframe=2,3,4,7,8,9)	X	3.61	70.84	17.44	2.23	80.0	± 9.6 %
		Y	3.84	70.79	17.56		80.0	
		Z	2.82	68.03	15.41		80.0	
10503-AAC	LTE-TDD (SC-FDMA, 100% RB, 5 MHz, QPSK, UL Subframe=2,3,4,7,8,9)	X	3.87	74.62	19.92	2.23	80.0	± 9.6 %
		Y	4.15	74.55	19.77		80.0	
		Z	2.95	71.29	18.21		80.0	
10504-AAC	LTE-TDD (SC-FDMA, 100% RB, 5 MHz, 16-QAM, UL Subframe=2,3,4,7,8,9)	X	3.57	70.04	17.95	2.23	80.0	± 9.6 %
		Y	3.80	70.13	17.99		80.0	
		Z	3.01	68.26	16.69		80.0	
10505-AAC	LTE-TDD (SC-FDMA, 100% RB, 5 MHz, 64-QAM, UL Subframe=2,3,4,7,8,9)	X	3.64	69.79	17.85	2.23	80.0	± 9.6 %
		Y	3.88	69.88	17.89		80.0	
		Z	3.09	68.12	16.62		80.0	
10506-AAC	LTE-TDD (SC-FDMA, 100% RB, 10 MHz, QPSK, UL Subframe=2,3,4,7,8,9)	X	4.39	74.26	19.71	2.23	80.0	± 9.6 %
		Y	4.71	74.37	19.61		80.0	
		Z	3.46	71.26	18.30		80.0	
10507-AAC	LTE-TDD (SC-FDMA, 100% RB, 10 MHz, 16-QAM, UL Subframe=2,3,4,7,8,9)	X	3.89	69.33	17.97	2.23	80.0	± 9.6 %
		Y	4.14	69.59	18.03		80.0	
		Z	3.38	67.80	17.02		80.0	

10508-AAC	LTE-TDD (SC-FDMA, 100% RB, 10 MHz, 64-QAM, UL Subframe=2,3,4,7,8,9)	X	3.95	68.98	17.84	2.23	80.0	± 9.6 %
		Y	4.21	69.23	17.90		80.0	
		Z	3.46	67.59	16.95		80.0	
10509-AAC	LTE-TDD (SC-FDMA, 100% RB, 15 MHz, QPSK, UL Subframe=2,3,4,7,8,9)	X	4.62	72.40	18.91	2.23	80.0	± 9.6 %
		Y	4.92	72.59	18.86		80.0	
		Z	3.86	70.20	17.85		80.0	
10510-AAC	LTE-TDD (SC-FDMA, 100% RB, 15 MHz, 16-QAM, UL Subframe=2,3,4,7,8,9)	X	4.34	68.87	17.84	2.23	80.0	± 9.6 %
		Y	4.61	69.18	17.91		80.0	
		Z	3.85	67.53	17.06		80.0	
10511-AAC	LTE-TDD (SC-FDMA, 100% RB, 15 MHz, 64-QAM, UL Subframe=2,3,4,7,8,9)	X	4.39	68.57	17.74	2.23	80.0	± 9.6 %
		Y	4.65	68.86	17.81		80.0	
		Z	3.92	67.35	17.00		80.0	
10512-AAC	LTE-TDD (SC-FDMA, 100% RB, 20 MHz, QPSK, UL Subframe=2,3,4,7,8,9)	X	4.95	74.43	19.59	2.23	80.0	± 9.6 %
		Y	5.29	74.60	19.52		80.0	
		Z	3.97	71.52	18.28		80.0	
10513-AAC	LTE-TDD (SC-FDMA, 100% RB, 20 MHz, 16-QAM, UL Subframe=2,3,4,7,8,9)	X	4.24	69.19	17.98	2.23	80.0	± 9.6 %
		Y	4.52	69.55	18.06		80.0	
		Z	3.73	67.67	17.13		80.0	
10514-AAC	LTE-TDD (SC-FDMA, 100% RB, 20 MHz, 64-QAM, UL Subframe=2,3,4,7,8,9)	X	4.25	68.69	17.82	2.23	80.0	± 9.6 %
		Y	4.51	69.03	17.90		80.0	
		Z	3.78	67.33	17.02		80.0	
10515-AAA	IEEE 802.11b WiFi 2.4 GHz (DSSS, 2 Mbps, 99pc duty cycle)	X	0.99	63.46	15.00	0.00	150.0	± 9.6 %
		Y	0.98	62.78	14.45		150.0	
		Z	0.99	63.59	14.96		150.0	
10516-AAA	IEEE 802.11b WiFi 2.4 GHz (DSSS, 5.5 Mbps, 99pc duty cycle)	X	0.69	72.54	18.63	0.00	150.0	± 9.6 %
		Y	0.56	68.11	16.08		150.0	
		Z	0.67	72.15	18.45		150.0	
10517-AAA	IEEE 802.11b WiFi 2.4 GHz (DSSS, 11 Mbps, 99pc duty cycle)	X	0.85	65.62	15.80	0.00	150.0	± 9.6 %
		Y	0.82	64.42	14.91		150.0	
		Z	0.84	65.62	15.72		150.0	
10518-AAA	IEEE 802.11a/h WiFi 5 GHz (OFDM, 9 Mbps, 99pc duty cycle)	X	4.53	66.80	16.29	0.00	150.0	± 9.6 %
		Y	4.59	66.58	16.17		150.0	
		Z	4.39	66.94	16.26		150.0	
10519-AAA	IEEE 802.11a/h WiFi 5 GHz (OFDM, 12 Mbps, 99pc duty cycle)	X	4.71	67.02	16.40	0.00	150.0	± 9.6 %
		Y	4.78	66.84	16.30		150.0	
		Z	4.54	67.11	16.34		150.0	
10520-AAA	IEEE 802.11a/h WiFi 5 GHz (OFDM, 18 Mbps, 99pc duty cycle)	X	4.56	66.98	16.32	0.00	150.0	± 9.6 %
		Y	4.63	66.80	16.22		150.0	
		Z	4.40	67.05	16.26		150.0	
10521-AAA	IEEE 802.11a/h WiFi 5 GHz (OFDM, 24 Mbps, 99pc duty cycle)	X	4.49	66.97	16.31	0.00	150.0	± 9.6 %
		Y	4.56	66.79	16.20		150.0	
		Z	4.33	67.02	16.25		150.0	
10522-AAA	IEEE 802.11a/h WiFi 5 GHz (OFDM, 36 Mbps, 99pc duty cycle)	X	4.56	67.08	16.40	0.00	150.0	± 9.6 %
		Y	4.62	66.86	16.28		150.0	
		Z	4.38	67.14	16.34		150.0	

10523-AAA	IEEE 802.11a/h WiFi 5 GHz (OFDM, 48 Mbps, 99pc duty cycle)	X	4.44	66.96	16.26	0.00	150.0	± 9.6 %
		Y	4.50	66.72	16.12		150.0	
		Z	4.31	67.14	16.26		150.0	
10524-AAA	IEEE 802.11a/h WiFi 5 GHz (OFDM, 54 Mbps, 99pc duty cycle)	X	4.50	67.00	16.37	0.00	150.0	± 9.6 %
		Y	4.57	66.78	16.25		150.0	
		Z	4.33	67.10	16.33		150.0	
10525-AAA	IEEE 802.11ac WiFi (20MHz, MCS0, 99pc duty cycle)	X	4.49	66.06	15.96	0.00	150.0	± 9.6 %
		Y	4.54	65.82	15.83		150.0	
		Z	4.36	66.21	15.95		150.0	
10526-AAA	IEEE 802.11ac WiFi (20MHz, MCS1, 99pc duty cycle)	X	4.65	66.41	16.10	0.00	150.0	± 9.6 %
		Y	4.72	66.20	15.98		150.0	
		Z	4.49	66.49	16.07		150.0	
10527-AAA	IEEE 802.11ac WiFi (20MHz, MCS2, 99pc duty cycle)	X	4.58	66.37	16.05	0.00	150.0	± 9.6 %
		Y	4.64	66.16	15.92		150.0	
		Z	4.42	66.47	16.01		150.0	
10528-AAA	IEEE 802.11ac WiFi (20MHz, MCS3, 99pc duty cycle)	X	4.59	66.39	16.08	0.00	150.0	± 9.6 %
		Y	4.65	66.18	15.96		150.0	
		Z	4.43	66.48	16.04		150.0	
10529-AAA	IEEE 802.11ac WiFi (20MHz, MCS4, 99pc duty cycle)	X	4.59	66.39	16.08	0.00	150.0	± 9.6 %
		Y	4.65	66.18	15.96		150.0	
		Z	4.43	66.48	16.04		150.0	
10531-AAA	IEEE 802.11ac WiFi (20MHz, MCS6, 99pc duty cycle)	X	4.58	66.48	16.09	0.00	150.0	± 9.6 %
		Y	4.65	66.29	15.97		150.0	
		Z	4.40	66.51	16.02		150.0	
10532-AAA	IEEE 802.11ac WiFi (20MHz, MCS7, 99pc duty cycle)	X	4.44	66.34	16.02	0.00	150.0	± 9.6 %
		Y	4.51	66.14	15.90		150.0	
		Z	4.28	66.37	15.96		150.0	
10533-AAA	IEEE 802.11ac WiFi (20MHz, MCS8, 99pc duty cycle)	X	4.60	66.44	16.07	0.00	150.0	± 9.6 %
		Y	4.66	66.22	15.94		150.0	
		Z	4.44	66.56	16.05		150.0	
10534-AAA	IEEE 802.11ac WiFi (40MHz, MCS0, 99pc duty cycle)	X	5.13	66.46	16.12	0.00	150.0	± 9.6 %
		Y	5.19	66.32	16.03		150.0	
		Z	4.99	66.46	16.09		150.0	
10535-AAA	IEEE 802.11ac WiFi (40MHz, MCS1, 99pc duty cycle)	X	5.20	66.64	16.21	0.00	150.0	± 9.6 %
		Y	5.25	66.49	16.10		150.0	
		Z	5.03	66.59	16.15		150.0	
10536-AAA	IEEE 802.11ac WiFi (40MHz, MCS2, 99pc duty cycle)	X	5.07	66.60	16.17	0.00	150.0	± 9.6 %
		Y	5.12	66.44	16.06		150.0	
		Z	4.92	66.60	16.13		150.0	
10537-AAA	IEEE 802.11ac WiFi (40MHz, MCS3, 99pc duty cycle)	X	5.12	66.56	16.15	0.00	150.0	± 9.6 %
		Y	5.18	66.41	16.05		150.0	
		Z	4.98	66.58	16.13		150.0	
10538-AAA	IEEE 802.11ac WiFi (40MHz, MCS4, 99pc duty cycle)	X	5.21	66.56	16.19	0.00	150.0	± 9.6 %
		Y	5.28	66.45	16.11		150.0	
		Z	5.05	66.54	16.15		150.0	
10540-AAA	IEEE 802.11ac WiFi (40MHz, MCS6, 99pc duty cycle)	X	5.14	66.58	16.22	0.00	150.0	± 9.6 %
		Y	5.20	66.45	16.12		150.0	
		Z	4.98	66.51	16.15		150.0	

10541-AAA	IEEE 802.11ac WiFi (40MHz, MCS7, 99pc duty cycle)	X	5.12	66.46	16.14	0.00	150.0	± 9.6 %
		Y	5.18	66.32	16.05		150.0	
		Z	4.96	66.43	16.09		150.0	
10542-AAA	IEEE 802.11ac WiFi (40MHz, MCS8, 99pc duty cycle)	X	5.27	66.53	16.19	0.00	150.0	± 9.6 %
		Y	5.33	66.40	16.10		150.0	
		Z	5.12	66.52	16.15		150.0	
10543-AAA	IEEE 802.11ac WiFi (40MHz, MCS9, 99pc duty cycle)	X	5.34	66.55	16.23	0.00	150.0	± 9.6 %
		Y	5.41	66.44	16.14		150.0	
		Z	5.19	66.58	16.21		150.0	
10544-AAA	IEEE 802.11ac WiFi (80MHz, MCS0, 99pc duty cycle)	X	5.45	66.57	16.12	0.00	150.0	± 9.6 %
		Y	5.49	66.44	16.03		150.0	
		Z	5.33	66.54	16.08		150.0	
10545-AAA	IEEE 802.11ac WiFi (80MHz, MCS1, 99pc duty cycle)	X	5.64	66.98	16.28	0.00	150.0	± 9.6 %
		Y	5.69	66.86	16.18		150.0	
		Z	5.50	66.96	16.25		150.0	
10546-AAA	IEEE 802.11ac WiFi (80MHz, MCS2, 99pc duty cycle)	X	5.50	66.75	16.18	0.00	150.0	± 9.6 %
		Y	5.56	66.68	16.11		150.0	
		Z	5.36	66.66	16.11		150.0	
10547-AAA	IEEE 802.11ac WiFi (80MHz, MCS3, 99pc duty cycle)	X	5.57	66.80	16.19	0.00	150.0	± 9.6 %
		Y	5.64	66.72	16.12		150.0	
		Z	5.44	66.76	16.16		150.0	
10548-AAA	IEEE 802.11ac WiFi (80MHz, MCS4, 99pc duty cycle)	X	5.80	67.67	16.61	0.00	150.0	± 9.6 %
		Y	5.91	67.72	16.59		150.0	
		Z	5.58	67.38	16.44		150.0	
10550-AAA	IEEE 802.11ac WiFi (80MHz, MCS6, 99pc duty cycle)	X	5.54	66.80	16.21	0.00	150.0	± 9.6 %
		Y	5.59	66.67	16.11		150.0	
		Z	5.42	66.83	16.21		150.0	
10551-AAA	IEEE 802.11ac WiFi (80MHz, MCS7, 99pc duty cycle)	X	5.54	66.82	16.18	0.00	150.0	± 9.6 %
		Y	5.59	66.72	16.10		150.0	
		Z	5.36	66.63	16.07		150.0	
10552-AAA	IEEE 802.11ac WiFi (80MHz, MCS8, 99pc duty cycle)	X	5.46	66.64	16.10	0.00	150.0	± 9.6 %
		Y	5.51	66.51	16.00		150.0	
		Z	5.34	66.66	16.08		150.0	
10553-AAA	IEEE 802.11ac WiFi (80MHz, MCS9, 99pc duty cycle)	X	5.54	66.66	16.14	0.00	150.0	± 9.6 %
		Y	5.59	66.56	16.06		150.0	
		Z	5.39	66.61	16.09		150.0	
10554-AAB	IEEE 802.11ac WiFi (160MHz, MCS0, 99pc duty cycle)	X	5.86	66.92	16.20	0.00	150.0	± 9.6 %
		Y	5.89	66.81	16.12		150.0	
		Z	5.75	66.87	16.15		150.0	
10555-AAB	IEEE 802.11ac WiFi (160MHz, MCS1, 99pc duty cycle)	X	5.98	67.22	16.33	0.00	150.0	± 9.6 %
		Y	6.03	67.12	16.25		150.0	
		Z	5.84	67.10	16.25		150.0	
10556-AAB	IEEE 802.11ac WiFi (160MHz, MCS2, 99pc duty cycle)	X	6.00	67.27	16.35	0.00	150.0	± 9.6 %
		Y	6.05	67.16	16.27		150.0	
		Z	5.88	67.20	16.30		150.0	
10557-AAB	IEEE 802.11ac WiFi (160MHz, MCS3, 99pc duty cycle)	X	5.96	67.16	16.31	0.00	150.0	± 9.6 %
		Y	6.02	67.08	16.25		150.0	
		Z	5.84	67.08	16.25		150.0	

10558-AAB	IEEE 802.11ac WiFi (160MHz, MCS4, 99pc duty cycle)	X	6.01	67.32	16.41	0.00	150.0	± 9.6 %
		Y	6.07	67.25	16.34		150.0	
		Z	5.85	67.15	16.31		150.0	
10560-AAB	IEEE 802.11ac WiFi (160MHz, MCS6, 99pc duty cycle)	X	6.01	67.17	16.37	0.00	150.0	± 9.6 %
		Y	6.06	67.10	16.31		150.0	
		Z	5.87	67.07	16.30		150.0	
10561-AAB	IEEE 802.11ac WiFi (160MHz, MCS7, 99pc duty cycle)	X	5.93	67.15	16.40	0.00	150.0	± 9.6 %
		Y	5.98	67.06	16.32		150.0	
		Z	5.80	67.05	16.32		150.0	
10562-AAB	IEEE 802.11ac WiFi (160MHz, MCS8, 99pc duty cycle)	X	6.04	67.49	16.57	0.00	150.0	± 9.6 %
		Y	6.12	67.48	16.53		150.0	
		Z	5.85	67.23	16.41		150.0	
10563-AAB	IEEE 802.11ac WiFi (160MHz, MCS9, 99pc duty cycle)	X	6.18	67.55	16.56	0.00	150.0	± 9.6 %
		Y	6.43	68.00	16.75		150.0	
		Z	5.95	67.17	16.35		150.0	
10564-AAA	IEEE 802.11g WiFi 2.4 GHz (DSSS-OFDM, 9 Mbps, 99pc duty cycle)	X	4.86	66.88	16.45	0.46	150.0	± 9.6 %
		Y	4.92	66.69	16.36		150.0	
		Z	4.71	66.96	16.39		150.0	
10565-AAA	IEEE 802.11g WiFi 2.4 GHz (DSSS-OFDM, 12 Mbps, 99pc duty cycle)	X	5.08	67.30	16.76	0.46	150.0	± 9.6 %
		Y	5.16	67.15	16.67		150.0	
		Z	4.90	67.36	16.69		150.0	
10566-AAA	IEEE 802.11g WiFi 2.4 GHz (DSSS-OFDM, 18 Mbps, 99pc duty cycle)	X	4.91	67.15	16.58	0.46	150.0	± 9.6 %
		Y	4.99	67.00	16.50		150.0	
		Z	4.74	67.18	16.50		150.0	
10567-AAA	IEEE 802.11g WiFi 2.4 GHz (DSSS-OFDM, 24 Mbps, 99pc duty cycle)	X	4.94	67.52	16.92	0.46	150.0	± 9.6 %
		Y	5.01	67.38	16.84		150.0	
		Z	4.77	67.57	16.87		150.0	
10568-AAA	IEEE 802.11g WiFi 2.4 GHz (DSSS-OFDM, 36 Mbps, 99pc duty cycle)	X	4.83	66.96	16.38	0.46	150.0	± 9.6 %
		Y	4.90	66.77	16.27		150.0	
		Z	4.63	66.92	16.25		150.0	
10569-AAA	IEEE 802.11g WiFi 2.4 GHz (DSSS-OFDM, 48 Mbps, 99pc duty cycle)	X	4.90	67.63	17.00	0.46	150.0	± 9.6 %
		Y	4.96	67.44	16.88		150.0	
		Z	4.75	67.78	17.00		150.0	
10570-AAA	IEEE 802.11g WiFi 2.4 GHz (DSSS-OFDM, 54 Mbps, 99pc duty cycle)	X	4.93	67.48	16.92	0.46	150.0	± 9.6 %
		Y	5.00	67.29	16.82		150.0	
		Z	4.76	67.58	16.89		150.0	
10571-AAA	IEEE 802.11b WiFi 2.4 GHz (DSSS, 1 Mbps, 90pc duty cycle)	X	1.18	64.69	15.93	0.46	130.0	± 9.6 %
		Y	1.20	64.37	15.58		130.0	
		Z	1.13	64.22	15.49		130.0	
10572-AAA	IEEE 802.11b WiFi 2.4 GHz (DSSS, 2 Mbps, 90pc duty cycle)	X	1.19	65.27	16.29	0.46	130.0	± 9.6 %
		Y	1.21	64.91	15.92		130.0	
		Z	1.14	64.74	15.83		130.0	
10573-AAA	IEEE 802.11b WiFi 2.4 GHz (DSSS, 5.5 Mbps, 90pc duty cycle)	X	2.77	92.16	26.12	0.46	130.0	± 9.6 %
		Y	1.86	83.27	22.47		130.0	
		Z	1.57	83.20	23.00		130.0	
10574-AAA	IEEE 802.11b WiFi 2.4 GHz (DSSS, 11 Mbps, 90pc duty cycle)	X	1.31	71.26	19.39	0.46	130.0	± 9.6 %
		Y	1.31	70.26	18.63		130.0	
		Z	1.20	70.00	18.67		130.0	

10575-AAA	IEEE 802.11g WiFi 2.4 GHz (DSSS-OFDM, 6 Mbps, 90pc duty cycle)	X	4.64	66.67	16.51	0.46	130.0	± 9.6 %
		Y	4.71	66.50	16.43		130.0	
		Z	4.47	66.69	16.39		130.0	
10576-AAA	IEEE 802.11g WiFi 2.4 GHz (DSSS-OFDM, 9 Mbps, 90pc duty cycle)	X	4.66	66.83	16.58	0.46	130.0	± 9.6 %
		Y	4.73	66.66	16.49		130.0	
		Z	4.50	66.89	16.47		130.0	
10577-AAA	IEEE 802.11g WiFi 2.4 GHz (DSSS-OFDM, 12 Mbps, 90pc duty cycle)	X	4.86	67.11	16.74	0.46	130.0	± 9.6 %
		Y	4.94	66.97	16.66		130.0	
		Z	4.67	67.12	16.61		130.0	
10578-AAA	IEEE 802.11g WiFi 2.4 GHz (DSSS-OFDM, 18 Mbps, 90pc duty cycle)	X	4.76	67.25	16.83	0.46	130.0	± 9.6 %
		Y	4.84	67.12	16.76		130.0	
		Z	4.57	67.26	16.72		130.0	
10579-AAA	IEEE 802.11g WiFi 2.4 GHz (DSSS-OFDM, 24 Mbps, 90pc duty cycle)	X	4.52	66.57	16.17	0.46	130.0	± 9.6 %
		Y	4.61	66.44	16.10		130.0	
		Z	4.33	66.48	15.99		130.0	
10580-AAA	IEEE 802.11g WiFi 2.4 GHz (DSSS-OFDM, 36 Mbps, 90pc duty cycle)	X	4.57	66.63	16.21	0.46	130.0	± 9.6 %
		Y	4.66	66.47	16.12		130.0	
		Z	4.36	66.53	16.01		130.0	
10581-AAA	IEEE 802.11g WiFi 2.4 GHz (DSSS-OFDM, 48 Mbps, 90pc duty cycle)	X	4.65	67.30	16.78	0.46	130.0	± 9.6 %
		Y	4.73	67.15	16.70		130.0	
		Z	4.48	67.34	16.69		130.0	
10582-AAA	IEEE 802.11g WiFi 2.4 GHz (DSSS-OFDM, 54 Mbps, 90pc duty cycle)	X	4.47	66.35	15.97	0.46	130.0	± 9.6 %
		Y	4.56	66.21	15.89		130.0	
		Z	4.26	66.25	15.78		130.0	
10583-AAA	IEEE 802.11a/h WiFi 5 GHz (OFDM, 6 Mbps, 90pc duty cycle)	X	4.64	66.67	16.51	0.46	130.0	± 9.6 %
		Y	4.71	66.50	16.43		130.0	
		Z	4.47	66.69	16.39		130.0	
10584-AAA	IEEE 802.11a/h WiFi 5 GHz (OFDM, 9 Mbps, 90pc duty cycle)	X	4.66	66.83	16.58	0.46	130.0	± 9.6 %
		Y	4.73	66.66	16.49		130.0	
		Z	4.50	66.89	16.47		130.0	
10585-AAA	IEEE 802.11a/h WiFi 5 GHz (OFDM, 12 Mbps, 90pc duty cycle)	X	4.86	67.11	16.74	0.46	130.0	± 9.6 %
		Y	4.94	66.97	16.66		130.0	
		Z	4.67	67.12	16.61		130.0	
10586-AAA	IEEE 802.11a/h WiFi 5 GHz (OFDM, 18 Mbps, 90pc duty cycle)	X	4.76	67.25	16.83	0.46	130.0	± 9.6 %
		Y	4.84	67.12	16.76		130.0	
		Z	4.57	67.26	16.72		130.0	
10587-AAA	IEEE 802.11a/h WiFi 5 GHz (OFDM, 24 Mbps, 90pc duty cycle)	X	4.52	66.57	16.17	0.46	130.0	± 9.6 %
		Y	4.61	66.44	16.10		130.0	
		Z	4.33	66.48	15.99		130.0	
10588-AAA	IEEE 802.11a/h WiFi 5 GHz (OFDM, 36 Mbps, 90pc duty cycle)	X	4.57	66.63	16.21	0.46	130.0	± 9.6 %
		Y	4.66	66.47	16.12		130.0	
		Z	4.36	66.53	16.01		130.0	
10589-AAA	IEEE 802.11a/h WiFi 5 GHz (OFDM, 48 Mbps, 90pc duty cycle)	X	4.65	67.30	16.78	0.46	130.0	± 9.6 %
		Y	4.73	67.15	16.70		130.0	
		Z	4.48	67.34	16.69		130.0	
10590-AAA	IEEE 802.11a/h WiFi 5 GHz (OFDM, 54 Mbps, 90pc duty cycle)	X	4.47	66.35	15.97	0.46	130.0	± 9.6 %
		Y	4.56	66.21	15.89		130.0	
		Z	4.26	66.25	15.78		130.0	

10591-AAA	IEEE 802.11n (HT Mixed, 20MHz, MCS0, 90pc duty cycle)	X	4.79	66.72	16.61	0.46	130.0	± 9.6 %
		Y	4.86	66.57	16.53		130.0	
		Z	4.63	66.78	16.50		130.0	
10592-AAA	IEEE 802.11n (HT Mixed, 20MHz, MCS1, 90pc duty cycle)	X	4.94	67.05	16.74	0.46	130.0	± 9.6 %
		Y	5.02	66.91	16.66		130.0	
		Z	4.75	67.07	16.63		130.0	
10593-AAA	IEEE 802.11n (HT Mixed, 20MHz, MCS2, 90pc duty cycle)	X	4.86	66.96	16.62	0.46	130.0	± 9.6 %
		Y	4.94	66.83	16.55		130.0	
		Z	4.67	66.95	16.49		130.0	
10594-AAA	IEEE 802.11n (HT Mixed, 20MHz, MCS3, 90pc duty cycle)	X	4.91	67.12	16.77	0.46	130.0	± 9.6 %
		Y	5.00	66.98	16.70		130.0	
		Z	4.72	67.12	16.65		130.0	
10595-AAA	IEEE 802.11n (HT Mixed, 20MHz, MCS4, 90pc duty cycle)	X	4.88	67.08	16.67	0.46	130.0	± 9.6 %
		Y	4.96	66.94	16.59		130.0	
		Z	4.69	67.10	16.56		130.0	
10596-AAA	IEEE 802.11n (HT Mixed, 20MHz, MCS5, 90pc duty cycle)	X	4.82	67.08	16.68	0.46	130.0	± 9.6 %
		Y	4.90	66.94	16.60		130.0	
		Z	4.62	67.07	16.55		130.0	
10597-AAA	IEEE 802.11n (HT Mixed, 20MHz, MCS6, 90pc duty cycle)	X	4.77	66.98	16.56	0.46	130.0	± 9.6 %
		Y	4.85	66.85	16.49		130.0	
		Z	4.57	66.94	16.41		130.0	
10598-AAA	IEEE 802.11n (HT Mixed, 20MHz, MCS7, 90pc duty cycle)	X	4.75	67.19	16.80	0.46	130.0	± 9.6 %
		Y	4.83	67.08	16.74		130.0	
		Z	4.56	67.16	16.67		130.0	
10599-AAA	IEEE 802.11n (HT Mixed, 40MHz, MCS0, 90pc duty cycle)	X	5.46	67.23	16.81	0.46	130.0	± 9.6 %
		Y	5.53	67.13	16.74		130.0	
		Z	5.31	67.22	16.74		130.0	
10600-AAA	IEEE 802.11n (HT Mixed, 40MHz, MCS1, 90pc duty cycle)	X	5.59	67.67	17.00	0.46	130.0	± 9.6 %
		Y	5.69	67.62	16.95		130.0	
		Z	5.40	67.56	16.88		130.0	
10601-AAA	IEEE 802.11n (HT Mixed, 40MHz, MCS2, 90pc duty cycle)	X	5.48	67.41	16.88	0.46	130.0	± 9.6 %
		Y	5.56	67.33	16.83		130.0	
		Z	5.31	67.36	16.79		130.0	
10602-AAA	IEEE 802.11n (HT Mixed, 40MHz, MCS3, 90pc duty cycle)	X	5.59	67.49	16.85	0.46	130.0	± 9.6 %
		Y	5.65	67.34	16.75		130.0	
		Z	5.41	67.42	16.75		130.0	
10603-AAA	IEEE 802.11n (HT Mixed, 40MHz, MCS4, 90pc duty cycle)	X	5.65	67.74	17.10	0.46	130.0	± 9.6 %
		Y	5.74	67.66	17.04		130.0	
		Z	5.48	67.71	17.02		130.0	
10604-AAA	IEEE 802.11n (HT Mixed, 40MHz, MCS5, 90pc duty cycle)	X	5.49	67.31	16.87	0.46	130.0	± 9.6 %
		Y	5.53	67.10	16.74		130.0	
		Z	5.37	67.37	16.83		130.0	
10605-AAA	IEEE 802.11n (HT Mixed, 40MHz, MCS6, 90pc duty cycle)	X	5.58	67.57	17.01	0.46	130.0	± 9.6 %
		Y	5.65	67.44	16.92		130.0	
		Z	5.40	67.46	16.88		130.0	
10606-AAA	IEEE 802.11n (HT Mixed, 40MHz, MCS7, 90pc duty cycle)	X	5.32	66.88	16.52	0.46	130.0	± 9.6 %
		Y	5.42	66.88	16.50		130.0	
		Z	5.18	66.90	16.45		130.0	

10607-AAA	IEEE 802.11ac WiFi (20MHz, MCS0, 90pc duty cycle)	X	4.63	66.06	16.24	0.46	130.0	± 9.6 %
		Y	4.69	65.87	16.14		130.0	
		Z	4.48	66.14	16.16		130.0	
10608-AAA	IEEE 802.11ac WiFi (20MHz, MCS1, 90pc duty cycle)	X	4.81	66.46	16.41	0.46	130.0	± 9.6 %
		Y	4.89	66.28	16.31		130.0	
		Z	4.62	66.47	16.30		130.0	
10609-AAA	IEEE 802.11ac WiFi (20MHz, MCS2, 90pc duty cycle)	X	4.70	66.31	16.25	0.46	130.0	± 9.6 %
		Y	4.78	66.14	16.15		130.0	
		Z	4.52	66.31	16.13		130.0	
10610-AAA	IEEE 802.11ac WiFi (20MHz, MCS3, 90pc duty cycle)	X	4.75	66.46	16.40	0.46	130.0	± 9.6 %
		Y	4.83	66.29	16.31		130.0	
		Z	4.57	66.47	16.29		130.0	
10611-AAA	IEEE 802.11ac WiFi (20MHz, MCS4, 90pc duty cycle)	X	4.67	66.27	16.25	0.46	130.0	± 9.6 %
		Y	4.74	66.11	16.17		130.0	
		Z	4.48	66.27	16.14		130.0	
10612-AAA	IEEE 802.11ac WiFi (20MHz, MCS5, 90pc duty cycle)	X	4.68	66.43	16.31	0.46	130.0	± 9.6 %
		Y	4.76	66.26	16.21		130.0	
		Z	4.47	66.40	16.18		130.0	
10613-AAA	IEEE 802.11ac WiFi (20MHz, MCS6, 90pc duty cycle)	X	4.68	66.30	16.19	0.46	130.0	± 9.6 %
		Y	4.76	66.16	16.10		130.0	
		Z	4.47	66.22	16.03		130.0	
10614-AAA	IEEE 802.11ac WiFi (20MHz, MCS7, 90pc duty cycle)	X	4.62	66.47	16.40	0.46	130.0	± 9.6 %
		Y	4.70	66.33	16.32		130.0	
		Z	4.44	66.44	16.27		130.0	
10615-AAA	IEEE 802.11ac WiFi (20MHz, MCS8, 90pc duty cycle)	X	4.67	66.12	16.05	0.46	130.0	± 9.6 %
		Y	4.75	65.95	15.95		130.0	
		Z	4.48	66.11	15.92		130.0	
10616-AAA	IEEE 802.11ac WiFi (40MHz, MCS0, 90pc duty cycle)	X	5.28	66.50	16.42	0.46	130.0	± 9.6 %
		Y	5.35	66.40	16.35		130.0	
		Z	5.12	66.44	16.33		130.0	
10617-AAA	IEEE 802.11ac WiFi (40MHz, MCS1, 90pc duty cycle)	X	5.35	66.70	16.50	0.46	130.0	± 9.6 %
		Y	5.42	66.55	16.40		130.0	
		Z	5.16	66.57	16.37		130.0	
10618-AAA	IEEE 802.11ac WiFi (40MHz, MCS2, 90pc duty cycle)	X	5.24	66.70	16.51	0.46	130.0	± 9.6 %
		Y	5.30	66.57	16.42		130.0	
		Z	5.08	66.64	16.42		130.0	
10619-AAA	IEEE 802.11ac WiFi (40MHz, MCS3, 90pc duty cycle)	X	5.25	66.50	16.35	0.46	130.0	± 9.6 %
		Y	5.33	66.41	16.28		130.0	
		Z	5.09	66.45	16.26		130.0	
10620-AAA	IEEE 802.11ac WiFi (40MHz, MCS4, 90pc duty cycle)	X	5.34	66.53	16.41	0.46	130.0	± 9.6 %
		Y	5.42	66.46	16.35		130.0	
		Z	5.16	66.45	16.31		130.0	
10621-AAA	IEEE 802.11ac WiFi (40MHz, MCS5, 90pc duty cycle)	X	5.34	66.65	16.59	0.46	130.0	± 9.6 %
		Y	5.41	66.55	16.51		130.0	
		Z	5.17	66.56	16.48		130.0	
10622-AAA	IEEE 802.11ac WiFi (40MHz, MCS6, 90pc duty cycle)	X	5.35	66.81	16.66	0.46	130.0	± 9.6 %
		Y	5.42	66.71	16.59		130.0	
		Z	5.16	66.65	16.52		130.0	

10623-AAA	IEEE 802.11ac WiFi (40MHz, MCS7, 90pc duty cycle)	X	5.23	66.36	16.32	0.46	130.0	± 9.6 %
		Y	5.30	66.25	16.24		130.0	
		Z	5.05	66.22	16.17		130.0	
10624-AAA	IEEE 802.11ac WiFi (40MHz, MCS8, 90pc duty cycle)	X	5.42	66.55	16.47	0.46	130.0	± 9.6 %
		Y	5.50	66.45	16.40		130.0	
		Z	5.25	66.47	16.36		130.0	
10625-AAA	IEEE 802.11ac WiFi (40MHz, MCS9, 90pc duty cycle)	X	5.75	67.41	16.95	0.46	130.0	± 9.6 %
		Y	5.89	67.51	16.98		130.0	
		Z	5.34	66.63	16.50		130.0	
10626-AAA	IEEE 802.11ac WiFi (80MHz, MCS0, 90pc duty cycle)	X	5.59	66.56	16.38	0.46	130.0	± 9.6 %
		Y	5.64	66.46	16.31		130.0	
		Z	5.45	66.47	16.28		130.0	
10627-AAA	IEEE 802.11ac WiFi (80MHz, MCS1, 90pc duty cycle)	X	5.82	67.13	16.63	0.46	130.0	± 9.6 %
		Y	5.88	67.03	16.55		130.0	
		Z	5.67	67.05	16.54		130.0	
10628-AAA	IEEE 802.11ac WiFi (80MHz, MCS2, 90pc duty cycle)	X	5.61	66.64	16.32	0.46	130.0	± 9.6 %
		Y	5.68	66.59	16.27		130.0	
		Z	5.44	66.46	16.18		130.0	
10629-AAA	IEEE 802.11ac WiFi (80MHz, MCS3, 90pc duty cycle)	X	5.69	66.69	16.34	0.46	130.0	± 9.6 %
		Y	5.78	66.69	16.31		130.0	
		Z	5.54	66.62	16.26		130.0	
10630-AAA	IEEE 802.11ac WiFi (80MHz, MCS4, 90pc duty cycle)	X	6.09	68.10	17.05	0.46	130.0	± 9.6 %
		Y	6.25	68.29	17.11		130.0	
		Z	5.78	67.54	16.72		130.0	
10631-AAA	IEEE 802.11ac WiFi (80MHz, MCS5, 90pc duty cycle)	X	5.99	67.90	17.13	0.46	130.0	± 9.6 %
		Y	6.12	67.99	17.15		130.0	
		Z	5.75	67.56	16.92		130.0	
10632-AAA	IEEE 802.11ac WiFi (80MHz, MCS6, 90pc duty cycle)	X	5.79	67.18	16.78	0.46	130.0	± 9.6 %
		Y	5.85	67.07	16.70		130.0	
		Z	5.67	67.21	16.76		130.0	
10633-AAA	IEEE 802.11ac WiFi (80MHz, MCS7, 90pc duty cycle)	X	5.68	66.80	16.43	0.46	130.0	± 9.6 %
		Y	5.74	66.74	16.37		130.0	
		Z	5.48	66.57	16.27		130.0	
10634-AAA	IEEE 802.11ac WiFi (80MHz, MCS8, 90pc duty cycle)	X	5.66	66.82	16.49	0.46	130.0	± 9.6 %
		Y	5.73	66.76	16.44		130.0	
		Z	5.50	66.72	16.40		130.0	
10635-AAA	IEEE 802.11ac WiFi (80MHz, MCS9, 90pc duty cycle)	X	5.54	66.19	15.93	0.46	130.0	± 9.6 %
		Y	5.62	66.14	15.87		130.0	
		Z	5.36	66.00	15.77		130.0	
10636-AAB	IEEE 802.11ac WiFi (160MHz, MCS0, 90pc duty cycle)	X	6.00	66.92	16.46	0.46	130.0	± 9.6 %
		Y	6.05	66.85	16.41		130.0	
		Z	5.88	66.82	16.36		130.0	
10637-AAB	IEEE 802.11ac WiFi (160MHz, MCS1, 90pc duty cycle)	X	6.16	67.31	16.64	0.46	130.0	± 9.6 %
		Y	6.21	67.23	16.58		130.0	
		Z	6.00	67.12	16.50		130.0	
10638-AAB	IEEE 802.11ac WiFi (160MHz, MCS2, 90pc duty cycle)	X	6.16	67.28	16.60	0.46	130.0	± 9.6 %
		Y	6.21	67.20	16.54		130.0	
		Z	6.02	67.18	16.51		130.0	

10639-AAB	IEEE 802.11ac WiFi (160MHz, MCS3, 90pc duty cycle)	X	6.13	67.21	16.61	0.46	130.0	± 9.6 %
		Y	6.20	67.17	16.57		130.0	
		Z	5.98	67.06	16.49		130.0	
10640-AAB	IEEE 802.11ac WiFi (160MHz, MCS4, 90pc duty cycle)	X	6.13	67.23	16.57	0.46	130.0	± 9.6 %
		Y	6.21	67.21	16.53		130.0	
		Z	5.95	66.98	16.40		130.0	
10641-AAB	IEEE 802.11ac WiFi (160MHz, MCS5, 90pc duty cycle)	X	6.19	67.17	16.55	0.46	130.0	± 9.6 %
		Y	6.24	67.06	16.48		130.0	
		Z	6.04	67.04	16.44		130.0	
10642-AAB	IEEE 802.11ac WiFi (160MHz, MCS6, 90pc duty cycle)	X	6.22	67.37	16.82	0.46	130.0	± 9.6 %
		Y	6.28	67.33	16.77		130.0	
		Z	6.06	67.23	16.70		130.0	
10643-AAB	IEEE 802.11ac WiFi (160MHz, MCS7, 90pc duty cycle)	X	6.06	67.09	16.58	0.46	130.0	± 9.6 %
		Y	6.12	67.02	16.52		130.0	
		Z	5.91	66.93	16.45		130.0	
10644-AAB	IEEE 802.11ac WiFi (160MHz, MCS8, 90pc duty cycle)	X	6.20	67.52	16.82	0.46	130.0	± 9.6 %
		Y	6.31	67.59	16.83		130.0	
		Z	5.97	67.13	16.57		130.0	
10645-AAB	IEEE 802.11ac WiFi (160MHz, MCS9, 90pc duty cycle)	X	6.41	67.77	16.91	0.46	130.0	± 9.6 %
		Y	6.76	68.49	17.23		130.0	
		Z	6.10	67.18	16.56		130.0	
10646-AAD	LTE-TDD (SC-FDMA, 1 RB, 5 MHz, QPSK, UL Subframe=2,7)	X	32.54	128.38	44.23	9.30	60.0	± 9.6 %
		Y	33.21	124.21	42.28		60.0	
		Z	8.58	97.27	34.21		60.0	
10647-AAC	LTE-TDD (SC-FDMA, 1 RB, 20 MHz, QPSK, UL Subframe=2,7)	X	24.86	122.50	42.74	9.30	60.0	± 9.6 %
		Y	27.83	120.75	41.46		60.0	
		Z	7.33	94.04	33.20		60.0	
10648-AAA	CDMA2000 (1x Advanced)	X	0.71	63.99	11.07	0.00	150.0	± 9.6 %
		Y	0.72	63.38	11.01		150.0	
		Z	0.57	62.72	9.40		150.0	
10652-AAB	LTE-TDD (OFDMA, 5 MHz, E-TM 3.1, Clipping 44%)	X	3.64	67.29	16.91	2.23	80.0	± 9.6 %
		Y	3.79	67.25	16.93		80.0	
		Z	3.31	66.63	16.20		80.0	
10653-AAB	LTE-TDD (OFDMA, 10 MHz, E-TM 3.1, Clipping 44%)	X	4.13	66.44	16.95	2.23	80.0	± 9.6 %
		Y	4.30	66.53	16.99		80.0	
		Z	3.84	65.89	16.44		80.0	
10654-AAB	LTE-TDD (OFDMA, 15 MHz, E-TM 3.1, Clipping 44%)	X	4.11	66.04	16.93	2.23	80.0	± 9.6 %
		Y	4.26	66.17	16.97		80.0	
		Z	3.86	65.50	16.46		80.0	
10655-AAB	LTE-TDD (OFDMA, 20 MHz, E-TM 3.1, Clipping 44%)	X	4.17	66.02	16.96	2.23	80.0	± 9.6 %
		Y	4.32	66.18	17.01		80.0	
		Z	3.93	65.42	16.50		80.0	

^E Uncertainty is determined using the max. deviation from linear response applying rectangular distribution and is expressed for the square of the field value.



Accredited by the Swiss Accreditation Service (SAS)
The Swiss Accreditation Service is one of the signatories to the EA
Multilateral Agreement for the recognition of calibration certificates

Accreditation No.: **SCS 0108**

Client **PC Test**

Certificate No: **D750V3-1161_Jul16**

CALIBRATION CERTIFICATE

Object **D750V3 - SN:1161**

Calibration procedure(s) **QA CAL-05.v9
Calibration procedure for dipole validation kits above 700 MHz**

Calibration date: **July 13, 2016**

✓ PM
8/9/16
Extended
7/2017
SC ✓

This calibration certificate documents the traceability to national standards, which realize the physical units of measurements (SI).
The measurements and the uncertainties with confidence probability are given on the following pages and are part of the certificate.

All calibrations have been conducted in the closed laboratory facility: environment temperature (22 ± 3)°C and humidity < 70%.

Calibration Equipment used (M&TE critical for calibration)

Primary Standards	ID #	Cal Date (Certificate No.)	Scheduled Calibration
Power meter NRP	SN: 104778	06-Apr-16 (No. 217-02288/02289)	Apr-17
Power sensor NRP-Z91	SN: 103244	06-Apr-16 (No. 217-02288)	Apr-17
Power sensor NRP-Z91	SN: 103245	06-Apr-16 (No. 217-02289)	Apr-17
Reference 20 dB Attenuator	SN: 5058 (20k)	05-Apr-16 (No. 217-02292)	Apr-17
Type-N mismatch combination	SN: 5047.2 / 06327	05-Apr-16 (No. 217-02295)	Apr-17
Reference Probe EX3DV4	SN: 7349	15-Jun-16 (No. EX3-7349_Jun16)	Jun-17
DAE4	SN: 601	30-Dec-15 (No. DAE4-601_Dec15)	Dec-16
Secondary Standards	ID #	Check Date (in house)	Scheduled Check
Power meter EPM-442A	SN: GB37480704	07-Oct-15 (No. 217-02222)	In house check: Oct-16
Power sensor HP 8481A	SN: US37292783	07-Oct-15 (No. 217-02222)	In house check: Oct-16
Power sensor HP 8481A	SN: MY41092317	07-Oct-15 (No. 217-02223)	In house check: Oct-16
RF generator R&S SMT-06	SN: 100972	15-Jun-15 (in house check Jun-15)	In house check: Oct-16
Network Analyzer HP 8753E	SN: US37390585	18-Oct-01 (in house check Oct-15)	In house check: Oct-16

Calibrated by: **Claudio Leubler** (Name) / **Laboratory Technician** (Function) / *[Signature]* (Signature)

Approved by: **Katja Pokovic** (Name) / **Technical Manager** (Function) / *[Signature]* (Signature)

Issued: July 13, 2016

This calibration certificate shall not be reproduced except in full without written approval of the laboratory.



Accredited by the Swiss Accreditation Service (SAS)
The Swiss Accreditation Service is one of the signatories to the EA
Multilateral Agreement for the recognition of calibration certificates

Glossary:

TSL	tissue simulating liquid
ConvF	sensitivity in TSL / NORM x,y,z
N/A	not applicable or not measured

Calibration is Performed According to the Following Standards:

- a) IEEE Std 1528-2013, "IEEE Recommended Practice for Determining the Peak Spatial-Averaged Specific Absorption Rate (SAR) in the Human Head from Wireless Communications Devices: Measurement Techniques", June 2013
- b) IEC 62209-1, "Procedure to measure the Specific Absorption Rate (SAR) for hand-held devices used in close proximity to the ear (frequency range of 300 MHz to 3 GHz)", February 2005
- c) IEC 62209-2, "Procedure to determine the Specific Absorption Rate (SAR) for wireless communication devices used in close proximity to the human body (frequency range of 30 MHz to 6 GHz)", March 2010
- d) KDB 865664, "SAR Measurement Requirements for 100 MHz to 6 GHz"

Additional Documentation:

- e) DASY4/5 System Handbook

Methods Applied and Interpretation of Parameters:

- *Measurement Conditions:* Further details are available from the Validation Report at the end of the certificate. All figures stated in the certificate are valid at the frequency indicated.
- *Antenna Parameters with TSL:* The dipole is mounted with the spacer to position its feed point exactly below the center marking of the flat phantom section, with the arms oriented parallel to the body axis.
- *Feed Point Impedance and Return Loss:* These parameters are measured with the dipole positioned under the liquid filled phantom. The impedance stated is transformed from the measurement at the SMA connector to the feed point. The Return Loss ensures low reflected power. No uncertainty required.
- *Electrical Delay:* One-way delay between the SMA connector and the antenna feed point. No uncertainty required.
- *SAR measured:* SAR measured at the stated antenna input power.
- *SAR normalized:* SAR as measured, normalized to an input power of 1 W at the antenna connector.
- *SAR for nominal TSL parameters:* The measured TSL parameters are used to calculate the nominal SAR result.

The reported uncertainty of measurement is stated as the standard uncertainty of measurement multiplied by the coverage factor $k=2$, which for a normal distribution corresponds to a coverage probability of approximately 95%.

Measurement Conditions

DASY system configuration, as far as not given on page 1.

DASY Version	DASY5	V52.8.8
Extrapolation	Advanced Extrapolation	
Phantom	Modular Flat Phantom	
Distance Dipole Center - TSL	15 mm	with Spacer
Zoom Scan Resolution	dx, dy, dz = 5 mm	
Frequency	750 MHz \pm 1 MHz	

Head TSL parameters

The following parameters and calculations were applied.

	Temperature	Permittivity	Conductivity
Nominal Head TSL parameters	22.0 °C	41.9	0.89 mho/m
Measured Head TSL parameters	(22.0 \pm 0.2) °C	40.9 \pm 6 %	0.91 mho/m \pm 6 %
Head TSL temperature change during test	< 0.5 °C	----	----

SAR result with Head TSL

SAR averaged over 1 cm ³ (1 g) of Head TSL	Condition	
SAR measured	250 mW input power	2.09 W/kg
SAR for nominal Head TSL parameters	normalized to 1W	8.17 W/kg \pm 17.0 % (k=2)

SAR averaged over 10 cm ³ (10 g) of Head TSL	condition	
SAR measured	250 mW input power	1.37 W/kg
SAR for nominal Head TSL parameters	normalized to 1W	5.39 W/kg \pm 16.5 % (k=2)

Body TSL parameters

The following parameters and calculations were applied.

	Temperature	Permittivity	Conductivity
Nominal Body TSL parameters	22.0 °C	55.5	0.96 mho/m
Measured Body TSL parameters	(22.0 \pm 0.2) °C	55.1 \pm 6 %	0.99 mho/m \pm 6 %
Body TSL temperature change during test	< 0.5 °C	----	----

SAR result with Body TSL

SAR averaged over 1 cm ³ (1 g) of Body TSL	Condition	
SAR measured	250 mW input power	2.16 W/kg
SAR for nominal Body TSL parameters	normalized to 1W	8.43 W/kg \pm 17.0 % (k=2)

SAR averaged over 10 cm ³ (10 g) of Body TSL	condition	
SAR measured	250 mW input power	1.41 W/kg
SAR for nominal Body TSL parameters	normalized to 1W	5.53 W/kg \pm 16.5 % (k=2)

Appendix (Additional assessments outside the scope of SCS 0108)

Antenna Parameters with Head TSL

Impedance, transformed to feed point	55.6 Ω - 0.9 j Ω
Return Loss	- 25.4 dB

Antenna Parameters with Body TSL

Impedance, transformed to feed point	50.2 Ω - 4.0 j Ω
Return Loss	- 28.0 dB

General Antenna Parameters and Design

Electrical Delay (one direction)	1.033 ns
----------------------------------	----------

After long term use with 100W radiated power, only a slight warming of the dipole near the feedpoint can be measured.

The dipole is made of standard semirigid coaxial cable. The center conductor of the feeding line is directly connected to the second arm of the dipole. The antenna is therefore short-circuited for DC-signals. On some of the dipoles, small end caps are added to the dipole arms in order to improve matching when loaded according to the position as explained in the "Measurement Conditions" paragraph. The SAR data are not affected by this change. The overall dipole length is still according to the Standard.

No excessive force must be applied to the dipole arms, because they might bend or the soldered connections near the feedpoint may be damaged.

Additional EUT Data

Manufactured by	SPEAG
Manufactured on	November 19, 2015