



FCC RF Test Report

APPLICANT : LG Electronics Mobile Comm USA
EQUIPMENT : Smart phone
BRAND NAME : LG
MODEL NAME : LG-X220g
FCC ID : ZNFX220G
STANDARD : FCC Part 15 Subpart C §15.247
CLASSIFICATION : (DTS) Digital Transmission System

The product was received on Dec. 03, 2015 and testing was completed on Jan. 19, 2016. We, SPORTON INTERNATIONAL (KUNSHAN) INC., would like to declare that the tested sample has been evaluated in accordance with the test procedures and has been in compliance with the applicable technical standards.

The test results in this report apply exclusively to the tested model / sample. Without written approval of SPORTON INTERNATIONAL (KUNSHAN) INC., the test report shall not be reproduced except in full.

Prepared by: James Huang / Manager

Approved by: Jones Tsai / Manager



SPORTON INTERNATIONAL (KUNSHAN) INC.
No. 3-2, PingXiang Road, Kunshan, Jiangsu Province, P. R. China



TABLE OF CONTENTS

- 1 GENERAL DESCRIPTION 5**
 - 1.1 Applicant 5
 - 1.2 Manufacturer 5
 - 1.3 Product Feature of Equipment Under Test 5
 - 1.4 Product Specification subjective to this standard 5
 - 1.5 Modification of EUT 6
 - 1.6 Testing Location 6
 - 1.7 Applicable Standards 6
- 2 TEST CONFIGURATION OF EQUIPMENT UNDER TEST 7**
 - 2.1 Carrier Frequency Channel 7
 - 2.2 Pre-Scanned RF Power 8
 - 2.3 Test Mode 9
 - 2.4 Connection Diagram of Test System 10
 - 2.5 Support Unit used in test configuration and system 12
 - 2.6 EUT Operation Test Setup 12
 - 2.7 Measurement Results Explanation Example 12
- 3 TEST RESULT 13**
 - 3.1 6dB Bandwidth Measurement 13
 - 3.2 Output Power Measurement 15
 - 3.3 Power Spectral Density Measurement 16
 - 3.4 Conducted Band Edges and Spurious Emission Measurement 18
 - 3.5 Radiated Band Edges and Spurious Emission Measurement 33
 - 3.6 AC Conducted Emission Measurement 41
 - 3.7 Antenna Requirements 47
- 4 LIST OF MEASURING EQUIPMENT 48**
- 5 UNCERTAINTY OF EVALUATION 49**

APPENDIX A. CONDUCTED TEST RESULTS

APPENDIX B. RADIATED TEST RESULTS



REVISION HISTORY

| REPORT NO. | VERSION | DESCRIPTION | ISSUED DATE |
|------------|---------|-------------------------|---------------|
| FR5D0302C | Rev. 01 | Initial issue of report | Jan. 19, 2016 |
| | | | |
| | | | |
| | | | |
| | | | |
| | | | |
| | | | |
| | | | |
| | | | |
| | | | |
| | | | |
| | | | |
| | | | |
| | | | |
| | | | |
| | | | |



SUMMARY OF TEST RESULT

| Report Section | FCC Rule | Description | Limit | Result | Remark |
|----------------|--------------------|--|--------------------------------|--------|-------------------------------------|
| 3.1 | 15.247(a)(2) | 6dB Bandwidth | $\geq 0.5\text{MHz}$ | Pass | - |
| 3.2 | 15.247(b) | Power Output Measurement | $\leq 30\text{dBm}$ | Pass | - |
| 3.3 | 15.247(e) | Power Spectral Density | $\leq 8\text{dBm}/3\text{kHz}$ | Pass | - |
| 3.4 | 15.247(d) | Conducted Band Edges | $\leq 20\text{dBc}$ | Pass | - |
| | | Conducted Spurious Emission | | Pass | - |
| 3.5 | 15.247(d) | Radiated Band Edges and Radiated Spurious Emission | 15.209(a) & 15.247(d) | Pass | Under limit 2.18 dB at 2483.760 MHz |
| 3.6 | 15.207 | AC Conducted Emission | 15.207(a) | Pass | Under limit 7.34 dB at 4.360 MHz |
| 3.7 | 15.203 & 15.247(b) | Antenna Requirement | N/A | Pass | - |



1 General Description

1.1 Applicant

LG Electronics Mobile Comm USA
1000 Sylvan Avenue Englewood Cliffs, NJ 07632

1.2 Manufacturer

Arima Communications Corp.
6F, No.866, Jhongjheng Rd., Jhonghe Dist., New Taipei City 23586, Taiwan

1.3 Product Feature of Equipment Under Test

| Product Feature | |
|--|--|
| Equipment | Smart phone |
| Brand Name | LG |
| Model Name | LG-X220g |
| FCC ID | ZNFX220G |
| EUT supports Radios application | GSM/GPRS/EGPRS(Downlink Only)/WCDMA/HSPA/HSPA+(16QAM uplink is not supported)/WLAN 2.4GHz 802.11b/g/n HT20/HT40/Bluetooth v3.0 + EDR/Bluetooth v4.0 LE |
| IMEI Code | Conducted: 353468062997251 Radiation: 353468062997100 Conduction: 353468062997145 |
| HW Version | 5542MB-002 |
| SW Version | LGX220g-00-V08a-334-20-NOV-11-2015+0 |
| EUT Stage | Production Unit |

Remark: The above EUT's information was declared by manufacturer. Please refer to the specifications or user's manual for more detailed description.

1.4 Product Specification subjective to this standard

| Product Specification subjective to this standard | |
|---|--|
| Tx/Rx Channel Frequency Range | 802.11b/g/n : 2412 MHz ~ 2462 MHz |
| Maximum (Peak) Output Power to Antenna | 802.11b : 18.82 dBm (0.0762 W) 802.11g : 22.59 dBm (0.1816 W) 802.11n HT20 : 21.46 dBm (0.1400 W) 802.11n HT40 : 21.77 dBm (0.1503 W) |
| Antenna Type/Gain | 802.11b/g/n : IFA Antenna with gain -0.10 dBi |
| Type of Modulation | 802.11b : DSSS (DBPSK / DQPSK / CCK) 802.11g/n : OFDM (BPSK / QPSK / 16QAM / 64QAM) |



1.5 Modification of EUT

No modifications are made to the EUT during all test items.

1.6 Testing Location

| | | | | |
|---------------------------|---|-----------|---------|-----------------------------|
| Test Site | SPORTON INTERNATIONAL (KUNSHAN) INC. | | | |
| Test Site Location | No. 3-2, PingXiang Road, Kunshan, Jiangsu Province, P. R. China TEL: +86-0512-5790-0158 FAX: +86-0512-5790-0958 | | | |
| Test Site No. | Sporton Site No. | | | FCC Registration No. |
| | TH01-KS | 03CH03-KS | CO01-KS | 306251 |

Note: The test site complies with ANSI C63.4 2009 requirement.

1.7 Applicable Standards

According to the specifications of the manufacturer, the EUT must comply with the requirements of the following standards:

- FCC Part 15 Subpart C §15.247
- FCC KDB Publication No. 558074 D01 DTS Meas. Guidance v03r03
- ANSI C63.10-2013

Remark:

1. All test items were verified and recorded according to the standards and without any deviation during the test.
2. This EUT has also been tested and complied with the requirements of FCC Part 15, Subpart B, recorded in a separate test report.



2 Test Configuration of Equipment Under Test

The EUT has been associated with peripherals and configuration operated in a manner tended to maximize its emission characteristics in a typical application. Frequency range investigated: conducted emission (150 kHz to 30 MHz) and radiated emission (9 kHz to the 10th harmonic of the highest fundamental frequency or to 40 GHz, whichever is lower). For radiated measurement, pre-scanned in three orthogonal panels, X, Y, Z. The worst cases were recorded in this report.

The final configuration from all the combinations and the worst-case data rates were investigated by measuring the maximum power across all the data rates and modulation modes under section 2.2.

Based on the worst configuration found above, the RF power setting is set individually to meet FCC compliance limit for the final conducted and radiated tests shown in section 2.3.

2.1 Carrier Frequency Channel

| Frequency Band | Channel | Freq. (MHz) | Channel | Freq. (MHz) |
|-----------------|---------|-------------|---------|-------------|
| 2400-2483.5 MHz | 1 | 2412 | 7 | 2442 |
| | 2 | 2417 | 8 | 2447 |
| | 3 | 2422 | 9 | 2452 |
| | 4 | 2427 | 10 | 2457 |
| | 5 | 2432 | 11 | 2462 |
| | 6 | 2437 | - | - |



2.2 Pre-Scanned RF Power

Preliminary tests were performed in different data rate and data rate associated with the highest power were chosen for full test shown in the following tables.

| 2.4GHz 802.11b RF Output Power (dBm) | | | | | | |
|--------------------------------------|-----------------|-----------|---------------------|-------|---------|--------|
| Power vs. Channel | | | Power vs. Data Rate | | | |
| Channel | Frequency (MHz) | Data Rate | Channel | 2Mbps | 5.5Mbps | 11Mbps |
| | | 1Mbps | | | | |
| CH 01 | 2412 MHz | 18.26 | CH 06 | 18.81 | 18.75 | 18.74 |
| CH 06 | 2437 MHz | 18.82 | | | | |
| CH 11 | 2462 MHz | 18.18 | | | | |

| 2.4GHz 802.11g RF Output Power (dBm) | | | | | | | | | | |
|--------------------------------------|-----------------|-----------|---------------------|-------|--------|--------|--------|--------|--------|--------|
| Power vs. Channel | | | Power vs. Data Rate | | | | | | | |
| Channel | Frequency (MHz) | Data Rate | Channel | 9Mbps | 12Mbps | 18Mbps | 24Mbps | 36Mbps | 48Mbps | 54Mbps |
| | | 6Mbps | | | | | | | | |
| CH 01 | 2412 MHz | 19.62 | CH 02 | 19.75 | 19.65 | 19.53 | 19.56 | 19.67 | 19.81 | 19.81 |
| CH 02 | 2417 MHz | 21.51 | | | | | | | | 22.59 |
| CH 06 | 2437 MHz | 20.95 | | | | | | | | 22.18 |
| CH 10 | 2457 MHz | 21.45 | | | | | | | | 22.54 |
| CH 11 | 2462 MHz | 19.88 | | | | | | | | 20.04 |

| 2.4GHz 802.11n HT20 RF Output Power (dBm) | | | | | | | | | | |
|---|-----------------|-----------|---------------------|-------|-------|-------|-------|-------|-------|-------|
| Power vs. Channel | | | Power vs. MCS Index | | | | | | | |
| Channel | Frequency (MHz) | MCS Index | Channel | MCS1 | MCS2 | MCS3 | MCS4 | MCS5 | MCS6 | MCS7 |
| | | MCS0 | | | | | | | | |
| CH 01 | 2412 MHz | 20.51 | CH 01 | 20.06 | 20.27 | 20.39 | 20.44 | 21.36 | 21.44 | 21.46 |
| CH 06 | 2437 MHz | 20.18 | | | | | | | | 21.12 |
| CH 11 | 2462 MHz | 20.47 | | | | | | | | 21.38 |

| 2.4GHz 802.11n HT40 RF Output Power (dBm) | | | | | | | | | | |
|---|-----------------|-----------|---------------------|-------|-------|-------|-------|-------|-------|-------|
| Power vs. Channel | | | Power vs. MCS Index | | | | | | | |
| Channel | Frequency (MHz) | MCS Index | Channel | MCS1 | MCS2 | MCS3 | MCS4 | MCS5 | MCS6 | MCS7 |
| | | MCS0 | | | | | | | | |
| CH 03 | 2422 MHz | 21.04 | CH 03 | 20.48 | 20.53 | 20.55 | 20.46 | 21.57 | 21.65 | 21.77 |
| CH 06 | 2437 MHz | 20.87 | | | | | | | | 21.34 |
| CH 09 | 2452 MHz | 20.92 | | | | | | | | 21.52 |



2.3 Test Mode

Final test mode of conducted test items and radiated spurious emissions are considering the modulation and worse data rates from the power table described in section 2.2.

<2.4GHz>

| Modulation | Data Rate |
|--------------|-----------|
| 802.11b | 1 Mbps |
| 802.11g | 54 Mbps |
| 802.11n HT20 | MCS7 |
| 802.11n HT40 | MCS7 |

| Test Cases | |
|---|---|
| AC Conducted Emission | Mode 1: GSM850 Idle + Bluetooth Link + WLAN Link + Earphone + USB Cable (Charging from Adapter) |
| Remark: For Radiated Test Cases, The tests were performance with Adapter, Earphone, and USB Cable. | |

2.4 Connection Diagram of Test System

<WLAN 802.11g/n HT40 Tx Mode>

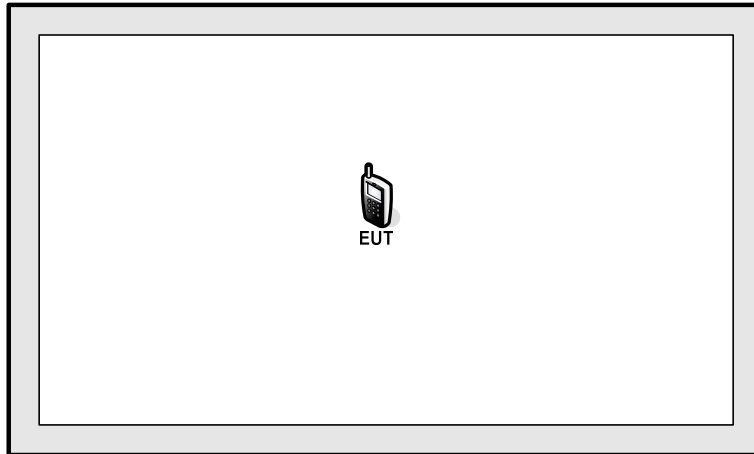

<WLAN 802.11b/n HT20 Tx Mode>

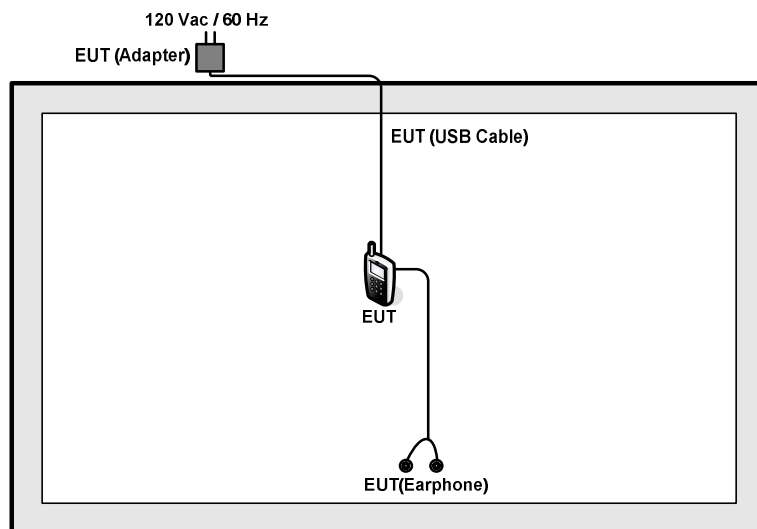

<AC Conducted Emission Mode>

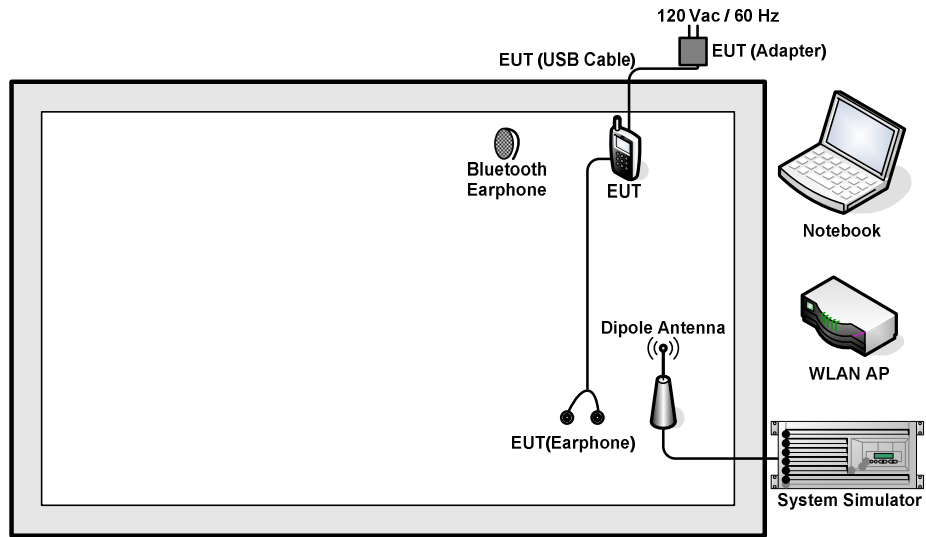

2.5 Support Unit used in test configuration and system

| Item | Equipment | Trade Name | Model Name | FCC ID | Data Cable | Power Cord |
|------|--------------------|------------|------------|-------------|------------|--|
| 1. | System Simulator | Anritsu | MT8820C | FCC DoC | N/A | Shielded, 1.5 m |
| 2. | Bluetooth Earphone | Nokia | BH-102 | PYAHS-107W | N/A | N/A |
| 3. | WLAN AP | D-Link | DIR-855 | KA2DIR855A2 | N/A | Shielded, 1.8 m |
| 4. | Notebook | Lenovo | G480 | N/A | N/A | AC I/P: Unshielded, 1.8 m DC O/P: Shielded, 1.8 m |
| 5. | SD Card | Kingston | 4GB | N/A | N/A | N/A |

2.6 EUT Operation Test Setup

For WLAN function, the engineering test program was provided and enabled to make EUT continuous transmit/receive.

For AC power line conducted emissions, the EUT was set to connect with the WLAN AP under large package sizes transmission.

2.7 Measurement Results Explanation Example

For all conducted test items:

The offset level is set in the spectrum analyzer to compensate the RF cable loss and attenuator factor between EUT conducted output port and spectrum analyzer. With the offset compensation, the spectrum analyzer reading level is exactly the EUT RF output level.

Example :

The spectrum analyzer offset is derived from RF cable loss.

Offset = RF cable loss.

Following shows an offset computation example with cable loss 5.5 dB.

$$\begin{aligned} \text{Offset(dB)} &= \text{RF cable loss(dB)}. \\ &= 5.5 \text{ (dB)} \end{aligned}$$

3 Test Result

3.1 6dB Bandwidth Measurement

3.1.1 Limit of 6dB Bandwidth

The minimum 6 dB bandwidth shall be at least 500 kHz.

3.1.2 Measuring Instruments

The measuring equipment is listed in the section 4 of this test report.

3.1.3 Test Procedures

1. The testing follows FCC KDB Publication No. 558074 DTS D01 Meas. Guidance v03r03.
2. The RF output of EUT was connected to the spectrum analyzer by RF cable and attenuator. The path loss was compensated to the results for each measurement.
3. Set to the maximum power setting and enable the EUT transmit continuously.
4. Make the measurement with the spectrum analyzer's resolution bandwidth (RBW) = 100 kHz. Set the Video bandwidth (VBW) = 300 kHz. In order to make an accurate measurement. The 6 dB bandwidth must be greater than 500 kHz.
5. Measure and record the results in the test report.

3.1.4 Test Setup





3.1.5 Test Result of 6dB Bandwidth

Please refer to Appendix A of this test report.

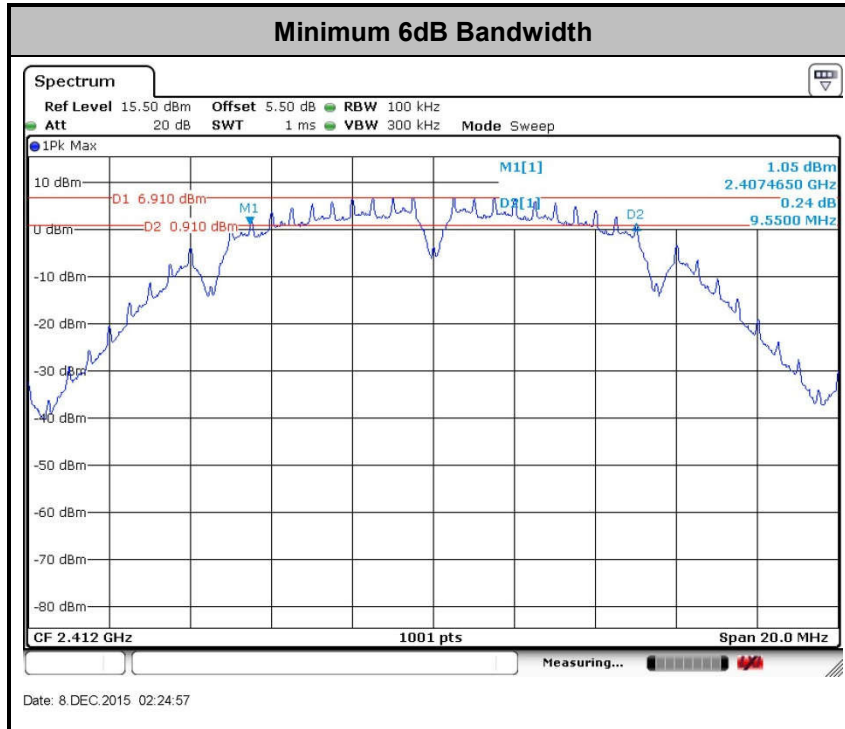

3.2 Output Power Measurement

3.2.1 Limit of Output Power

For systems using digital modulation in the 2400-2483.5MHz, the limit for peak output power is 30dBm. If transmitting Antenna of directional gain greater than 6dBi are used the peak output power from the intentional radiator shall be reduced below the above stated value by the amount in dB that the directional gain of the Antenna exceeds 6 dBi. In case of point-to-point operation, the limit has to be reduced by 1dB for every 3dB that the directional gain of the Antenna exceeds 6dBi.

3.2.2 Measuring Instruments

The measuring equipment is listed in the section 4 of this test report.

3.2.3 Test Procedures

1. The testing follows the Measurement Procedure of FCC KDB No. 558074 DTS D01 Meas. Guidance v03r03 section 9.1.2 PKPM1 Peak power meter method.
2. The RF output of EUT was connected to the power meter by RF cable and attenuator. The path loss was compensated to the results for each measurement.
3. Set to the maximum power setting and enable the EUT transmit continuously.
4. Measure the conducted output power and record the results in the test report.

3.2.4 Test Setup

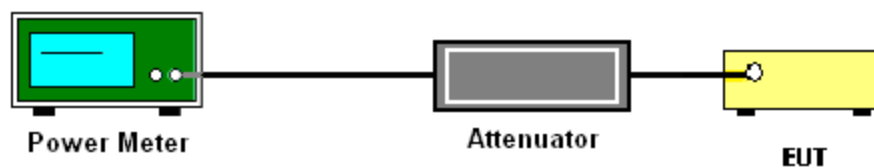

3.2.5 Test Result of Peak Output Power

Please refer to Appendix A of this test report.

3.2.6 Test Result of Average output Power (Reporting Only)

Please refer to Appendix A of this test report.

3.3 Power Spectral Density Measurement

3.3.1 Limit of Power Spectral Density

The peak power spectral density shall not be greater than 8dBm in any 3kHz band at any time interval of continuous transmission.

3.3.2 Measuring Instruments

The measuring equipment is listed in the section 4 of this test report.

3.3.3 Test Procedures

1. The testing follows Measurement Procedure 10.2 Method PKPSD of FCC KDB Publication No. 558074 D01 DTS Meas. Guidance v03r03
2. The RF output of EUT was connected to the spectrum analyzer by RF cable and attenuator. The path loss was compensated to the results for each measurement.
3. Set to the maximum power setting and enable the EUT transmit continuously.
4. Make the measurement with the spectrum analyzer's resolution bandwidth (RBW) = 3 kHz. Video bandwidth VBW = 10 kHz In order to make an accurate measurement, set the span to 1.5 times DTS Channel Bandwidth. (6dB BW)
5. Detector = peak, Sweep time = auto couple, Trace mode = max hold, Allow trace to fully stabilize. Use the peak marker function to determine the maximum power level.
6. Measure and record the results in the test report.

3.3.4 Test Setup

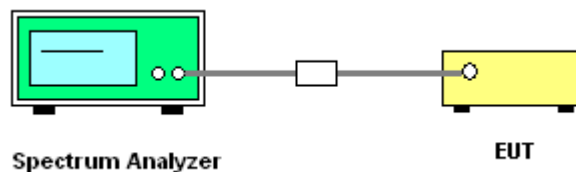



3.3.5 Test Result of Power Spectral Density

Please refer to Appendix A of this test report.

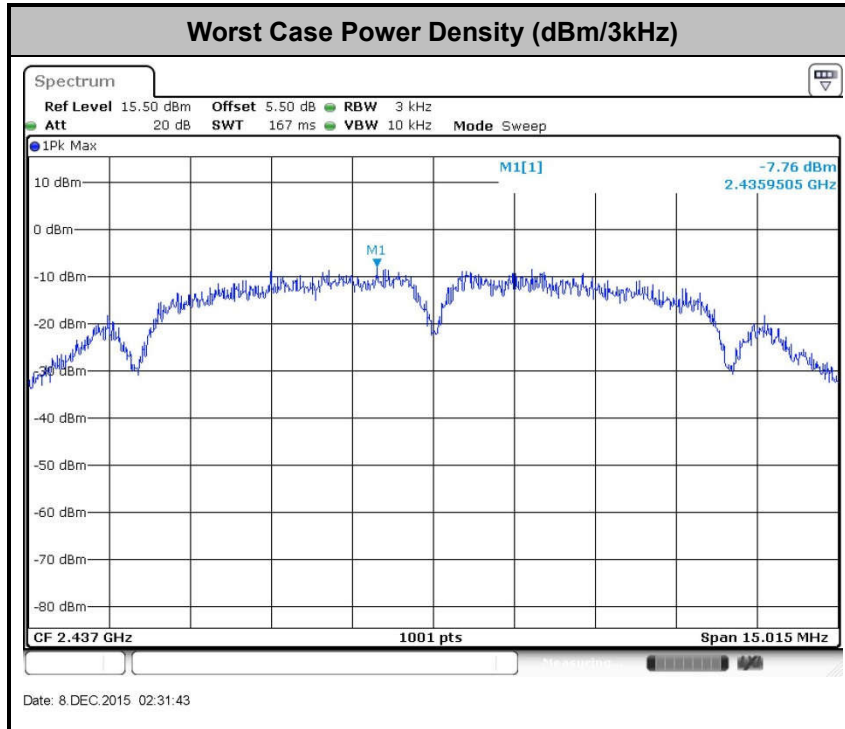

3.4 Conducted Band Edges and Spurious Emission Measurement

3.4.1 Limit of Conducted Band Edges and Spurious Emission Measurement

In any 100 kHz bandwidth outside of the authorized frequency band, the emissions which fall in the non-restricted bands shall be attenuated at least 20 dB / 30dB relative to the maximum PSD level in 100 kHz by RF conducted measurement and radiated emissions which fall in the restricted bands, as defined in Section 15.205(a), must also comply with the radiated emission limits specified in Section 15.209(a).

3.4.2 Measuring Instruments

The measuring equipment is listed in the section 4 of this test report.

3.4.3 Test Procedures

1. The testing follows FCC KDB Publication No. 558074 D01 DTS Meas. Guidance v03r03.
2. The RF output of EUT was connected to the spectrum analyzer by RF cable and attenuator. The path loss was compensated to the results for each measurement.
3. Set to the maximum power setting and enable the EUT transmit continuously.
4. Set RBW = 100 kHz, VBW=300 kHz, Peak Detector. Unwanted Emissions measured in any 100 kHz bandwidth outside of the authorized frequency band shall be attenuated by at least 20 dB relative to the maximum in-band peak PSD level in 100 kHz when maximum peak conducted output power procedure is used. If the transmitter complies with the conducted power limits based on the use of RMS averaging over a time interval, the attenuation required under this paragraph shall be 30 dB instead of 20 dB per 15.247(d).
5. Measure and record the results in the test report.
6. The RF fundamental frequency should be excluded against the limit line in the operating frequency band.

3.4.4 Test Setup

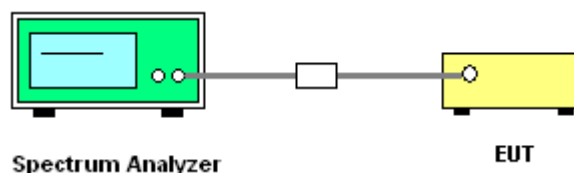



3.4.5 Test Result of Conducted Band Edges and Spurious Emission

| | | | |
|----------------|------------|---------------------|------------|
| Test Mode : | 802.11b | Temperature : | 24~25°C |
| Test Band : | 2.4GHz Low | Relative Humidity : | 49~51% |
| Test Channel : | 01 | Test Engineer : | Issac Song |

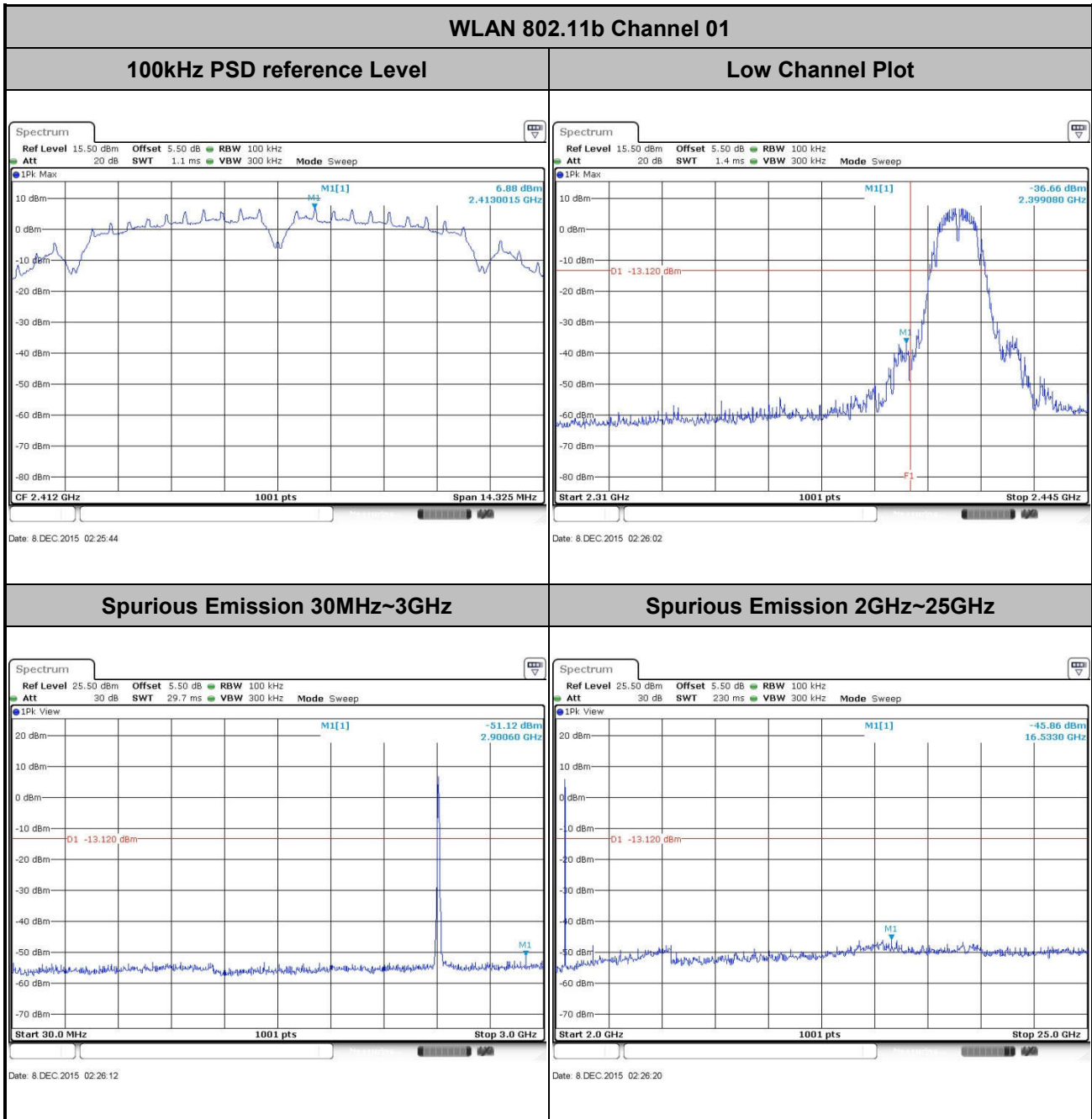



| | | | |
|----------------|------------|---------------------|------------|
| Test Mode : | 802.11b | Temperature : | 24~25°C |
| Test Band : | 2.4GHz Mid | Relative Humidity : | 49~51% |
| Test Channel : | 06 | Test Engineer : | Issac Song |

WLAN 802.11b Channel 06

100kHz PSD reference Level

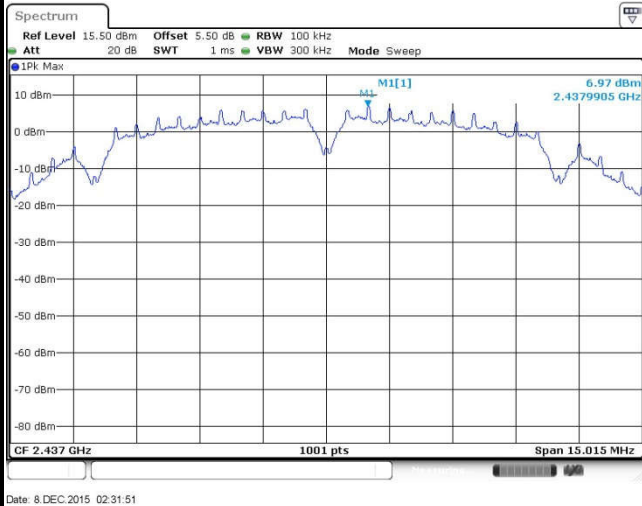

Spurious Emission 30MHz~3GHz

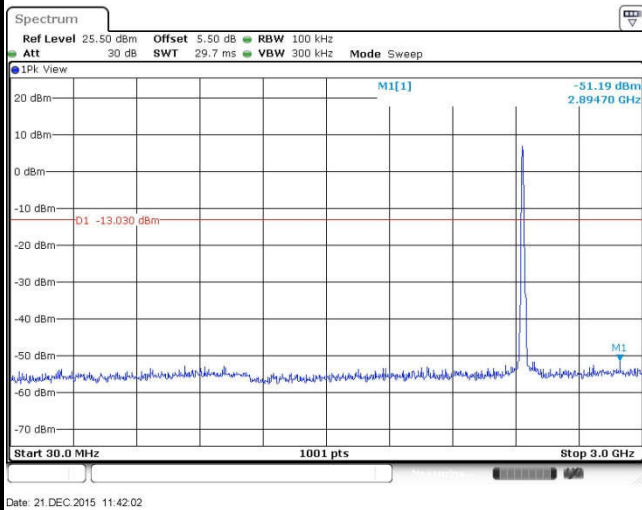

Spurious Emission 2GHz~25GHz

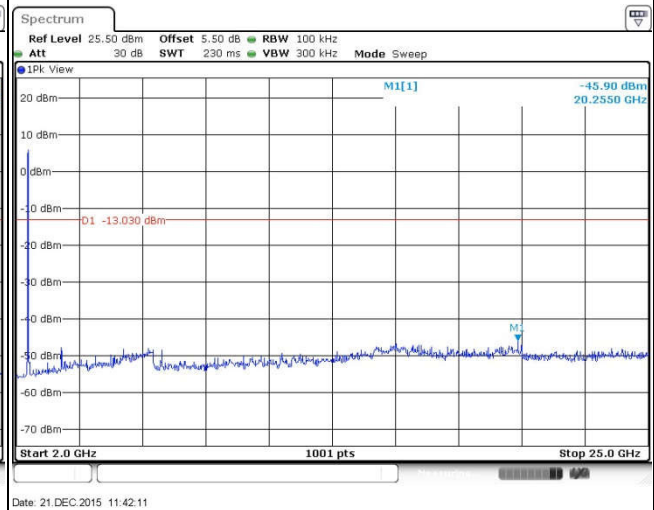



| | | | |
|----------------|-------------|---------------------|------------|
| Test Mode : | 802.11b | Temperature : | 24~25°C |
| Test Band : | 2.4GHz High | Relative Humidity : | 49~51% |
| Test Channel : | 11 | Test Engineer : | Issac Song |

WLAN 802.11b Channel 11

100kHz PSD reference Level

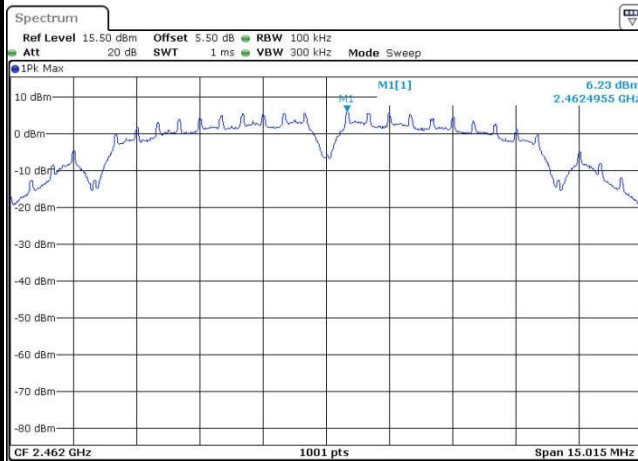

Date: 8 DEC.2015 02:34:07

High Channel Plot

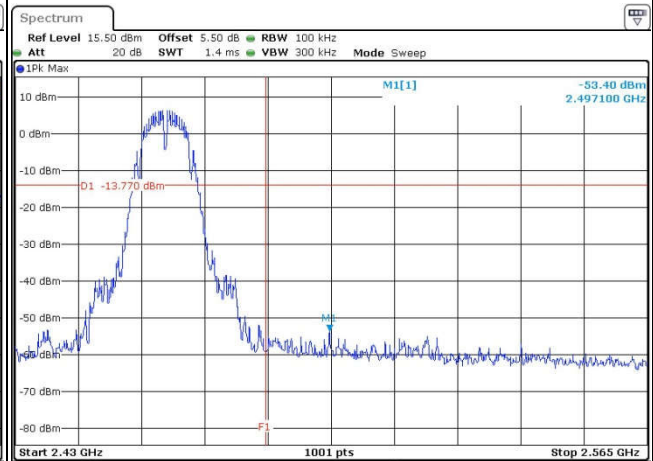

Date: 8 DEC.2015 02:34:21

Spurious Emission 30MHz~3GHz

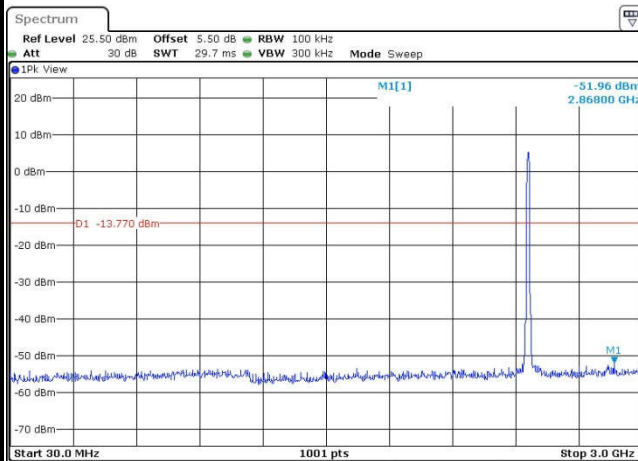

Date: 8 DEC.2015 02:34:32

Spurious Emission 2GHz~25GHz

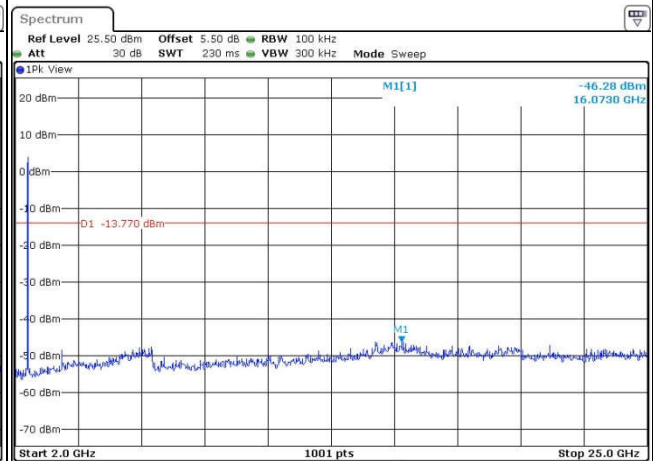

Date: 8 DEC.2015 02:34:40



| | | | |
|----------------|------------|---------------------|------------|
| Test Mode : | 802.11g | Temperature : | 24~25°C |
| Test Band : | 2.4GHz Low | Relative Humidity : | 49~51% |
| Test Channel : | 01 | Test Engineer : | Issac Song |

WLAN 802.11g Channel 01

100kHz PSD reference Level

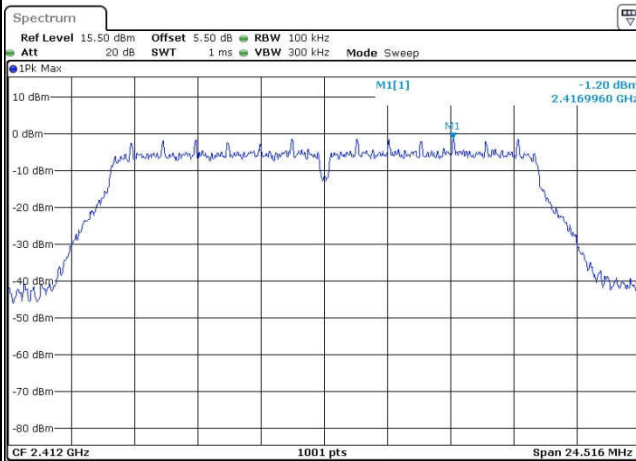

Date: 19 DEC.2015 03:15:49

Low Channel Plot

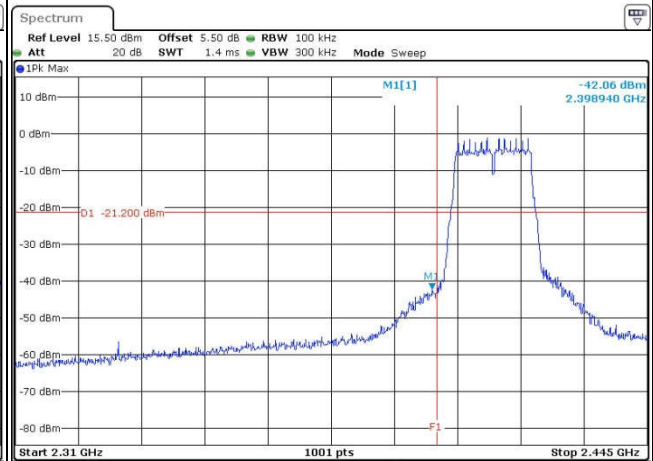

Date: 19 DEC.2015 03:16:30

Spurious Emission 30MHz~3GHz

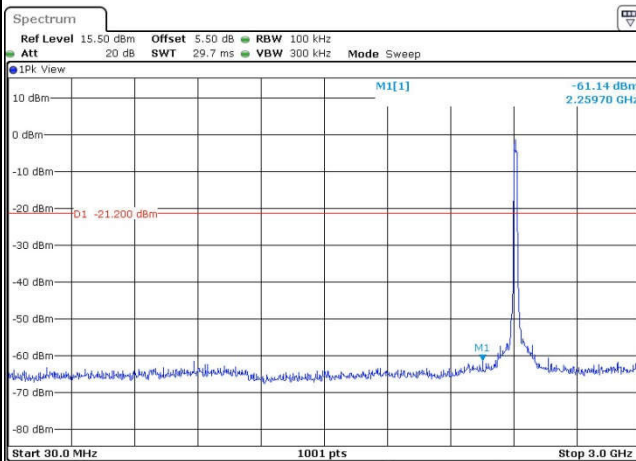

Date: 19 DEC.2015 03:19:28

Spurious Emission 2GHz~25GHz

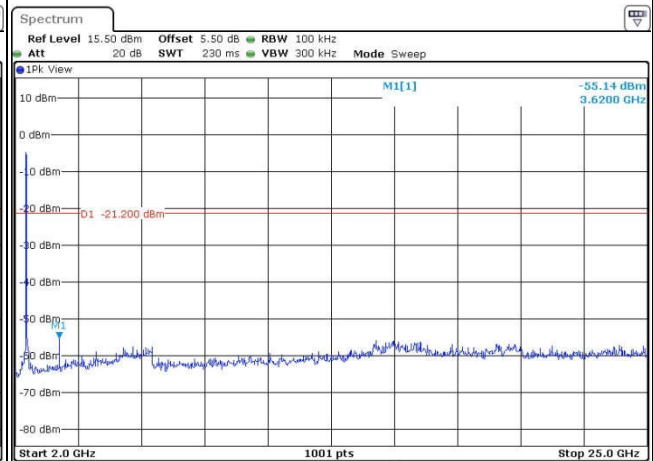

Date: 19 DEC.2015 03:19:37



| | | | |
|----------------|------------|---------------------|------------|
| Test Mode : | 802.11g | Temperature : | 24~25°C |
| Test Band : | 2.4GHz Low | Relative Humidity : | 49~51% |
| Test Channel : | 02 | Test Engineer : | Issac Song |

WLAN 802.11g Channel 01

100kHz PSD reference Level

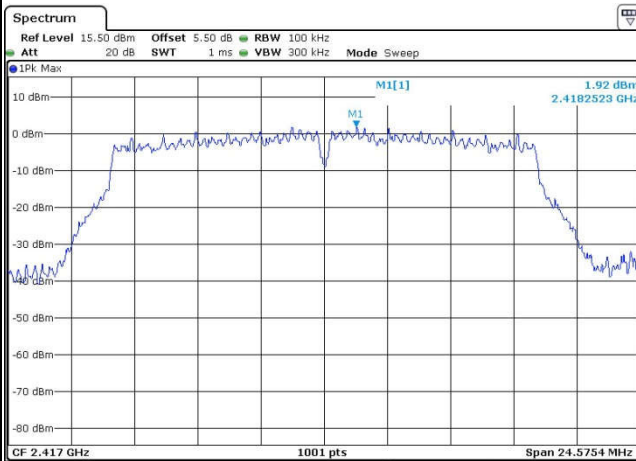

Date: 19 JAN 2016 13:39:59

Low Channel Plot

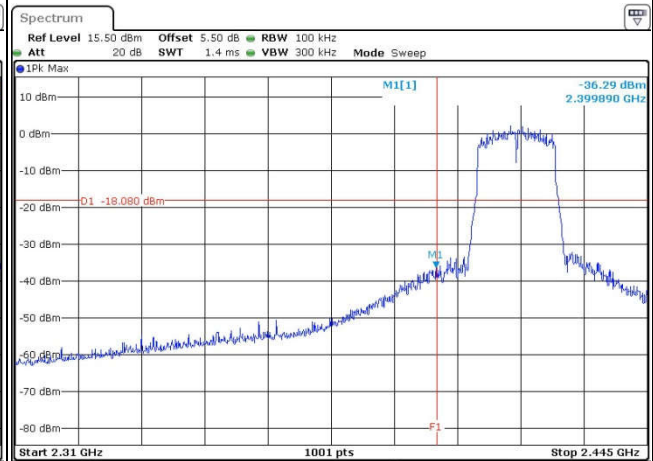

Date: 19 JAN 2016 13:42:57

Spurious Emission 30MHz~3GHz

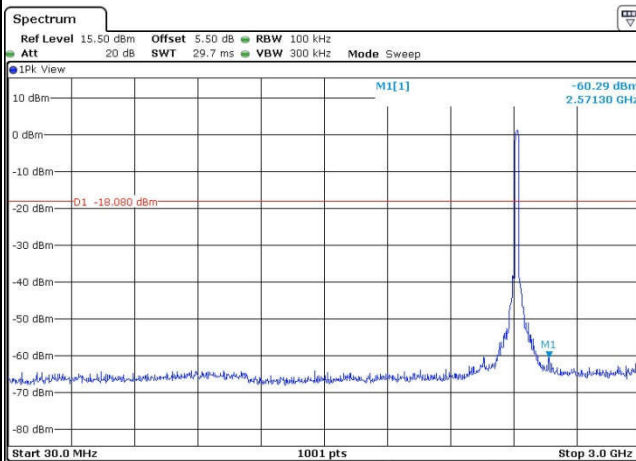

Date: 19 JAN 2016 13:46:14

Spurious Emission 2GHz~25GHz

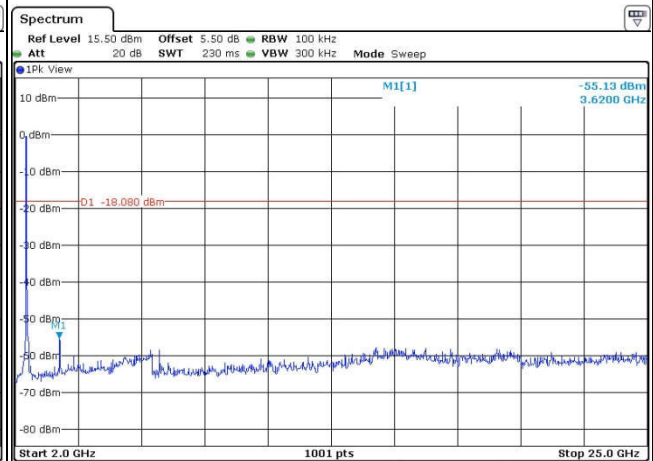

Date: 19 JAN 2016 13:47:52



| | | | |
|----------------|------------|---------------------|------------|
| Test Mode : | 802.11g | Temperature : | 24~25°C |
| Test Band : | 2.4GHz Mid | Relative Humidity : | 49~51% |
| Test Channel : | 06 | Test Engineer : | Issac Song |

WLAN 802.11g Channel 06

100kHz PSD reference Level

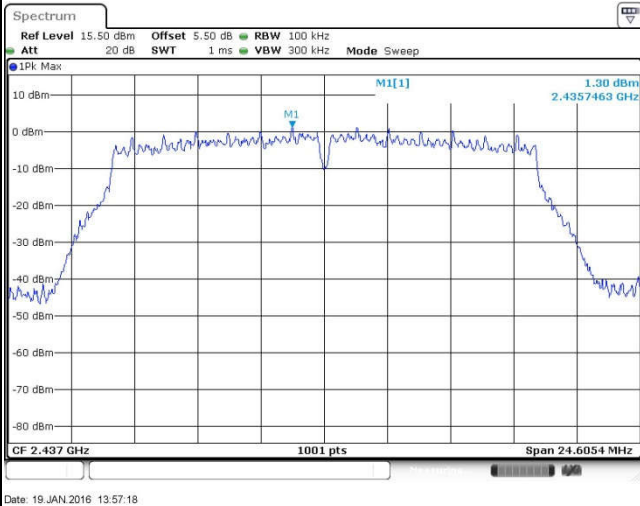

Spurious Emission 30MHz~3GHz

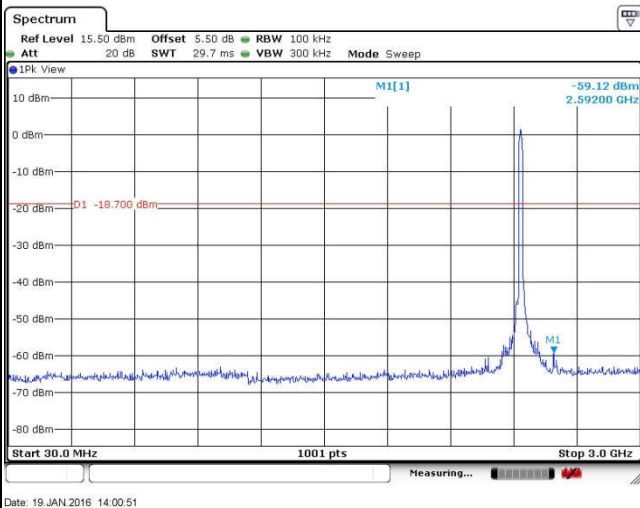

Spurious Emission 2GHz~25GHz

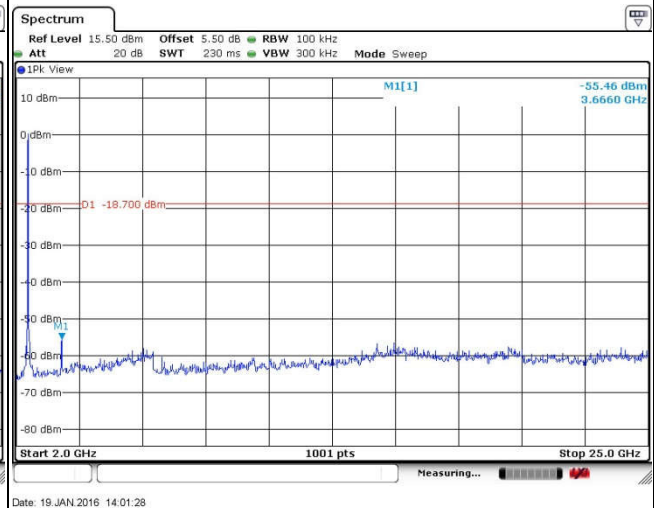



| | | | |
|----------------|-------------|---------------------|------------|
| Test Mode : | 802.11g | Temperature : | 24~25°C |
| Test Band : | 2.4GHz High | Relative Humidity : | 49~51% |
| Test Channel : | 10 | Test Engineer : | Issac Song |

WLAN 802.11g Channel 11

100kHz PSD reference Level

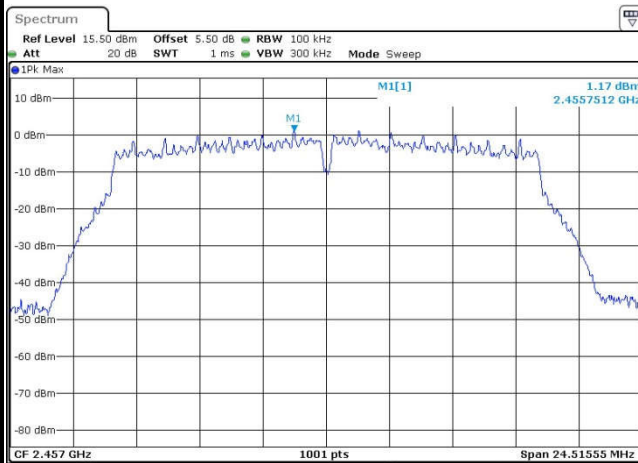

Date: 19.JAN.2016 14:06:49

High Channel Plot

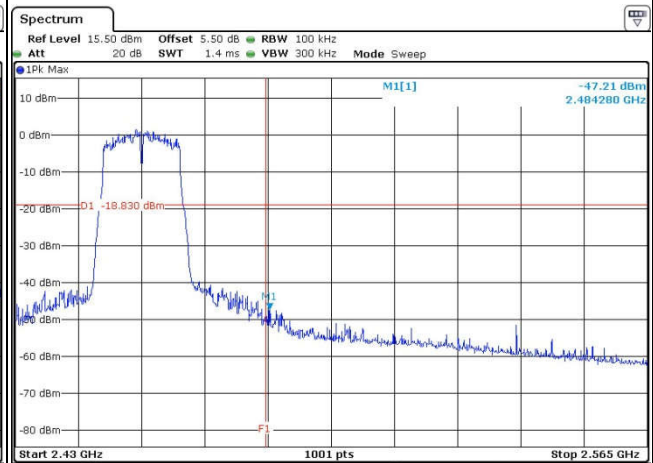

Date: 19.JAN.2016 14:09:38

Spurious Emission 30MHz~3GHz

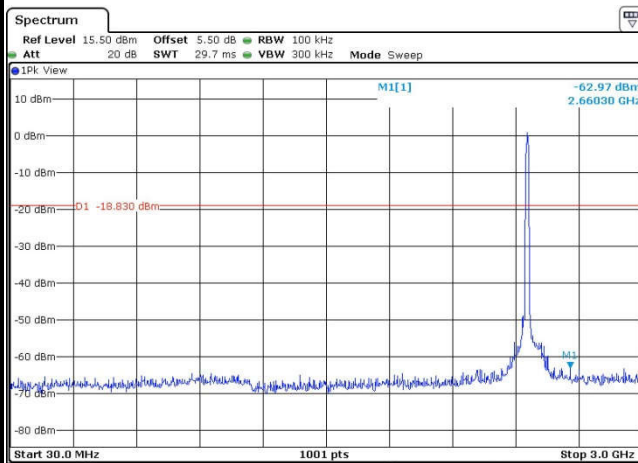

Date: 19.JAN.2016 14:12:49

Spurious Emission 2GHz~25GHz

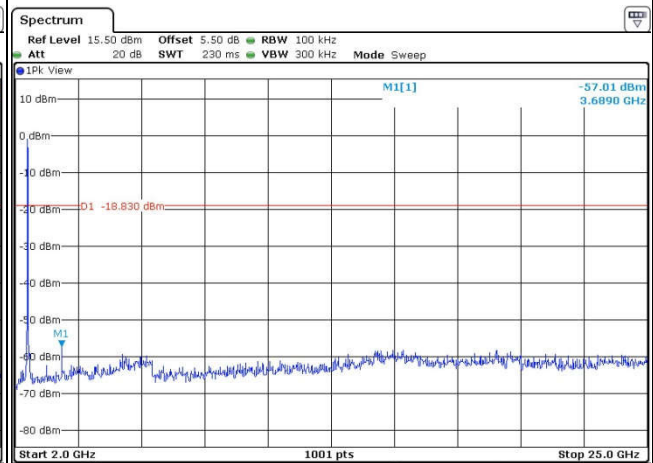

Date: 19.JAN.2016 14:13:30



| | | | |
|----------------|-------------|---------------------|------------|
| Test Mode : | 802.11g | Temperature : | 24~25°C |
| Test Band : | 2.4GHz High | Relative Humidity : | 49~51% |
| Test Channel : | 11 | Test Engineer : | Issac Song |

WLAN 802.11g Channel 11

100kHz PSD reference Level

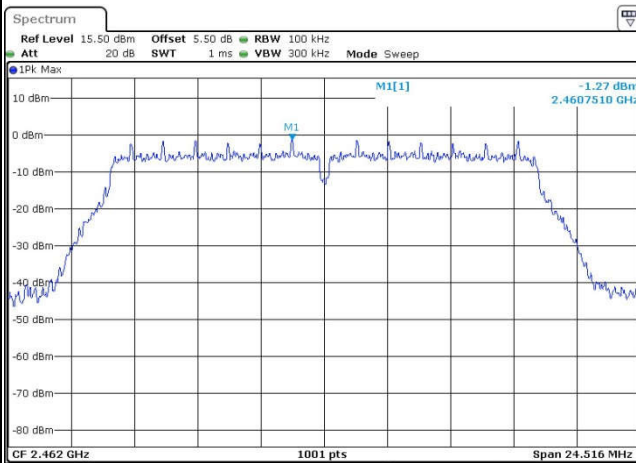

Date: 19 DEC.2015 03:30:21

High Channel Plot

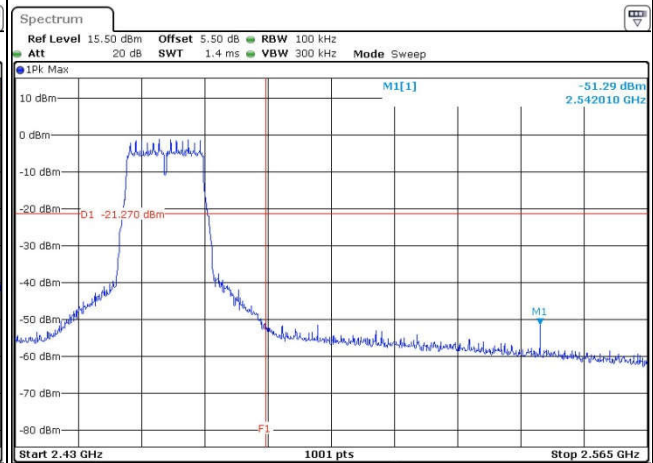

Date: 19 DEC.2015 03:30:40

Spurious Emission 30MHz~3GHz

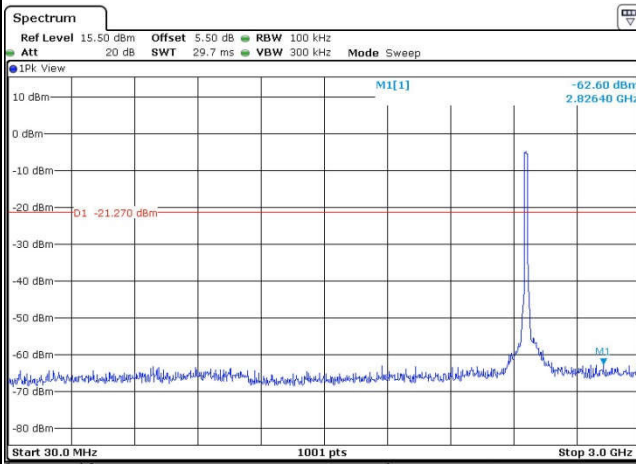

Date: 19 DEC.2015 03:32:19

Spurious Emission 2GHz~25GHz

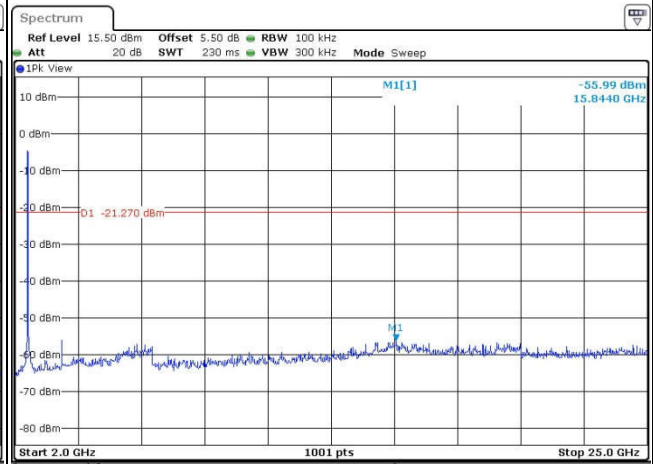

Date: 19 DEC.2015 03:31:37



| | | | |
|----------------|--------------|---------------------|------------|
| Test Mode : | 802.11n HT20 | Temperature : | 24~25°C |
| Test Band : | 2.4GHz Low | Relative Humidity : | 49~51% |
| Test Channel : | 01 | Test Engineer : | Issac Song |

WLAN 802.11n HT20 Channel 01

100kHz PSD reference Level

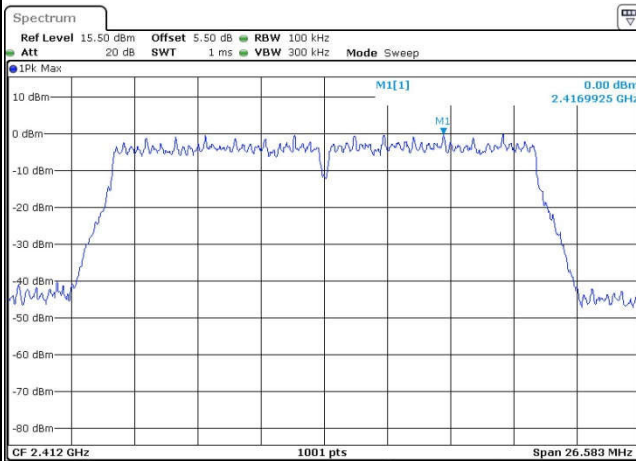

Date: 19 DEC. 2015 03:38:25

Low Channel Plot

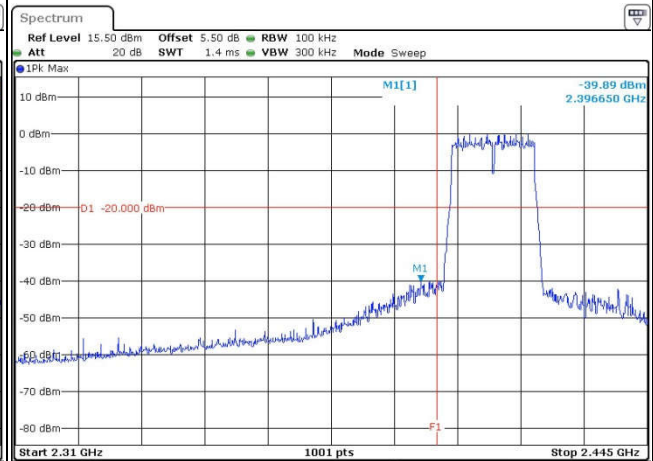

Date: 19 DEC. 2015 03:38:45

Spurious Emission 30MHz~3GHz

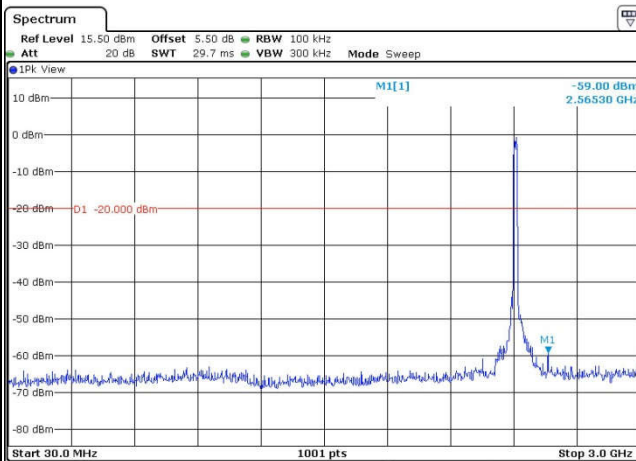

Date: 19 DEC. 2015 03:40:41

Spurious Emission 2GHz~25GHz

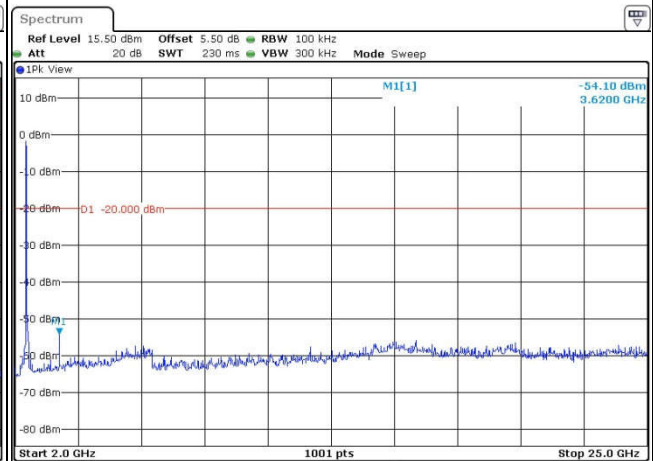

Date: 19 DEC. 2015 03:39:44



| | | | |
|----------------|--------------|---------------------|------------|
| Test Mode : | 802.11n HT20 | Temperature : | 24~25°C |
| Test Band : | 2.4GHz Mid | Relative Humidity : | 49~51% |
| Test Channel : | 06 | Test Engineer : | Issac Song |

WLAN 802.11n HT20 Channel 06

100kHz PSD reference Level

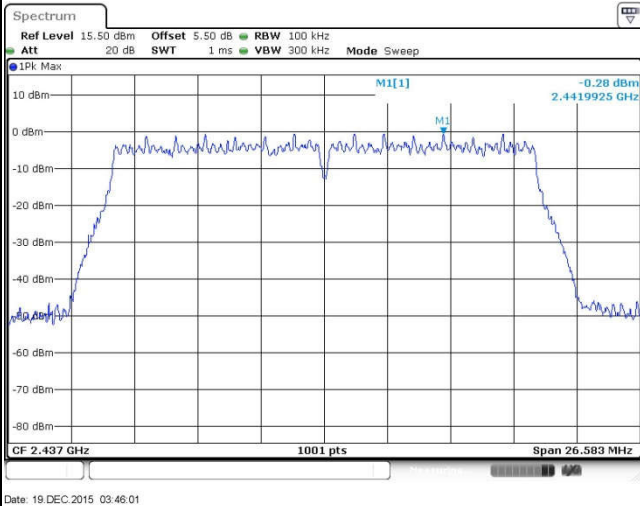

Spurious Emission 30MHz~3GHz

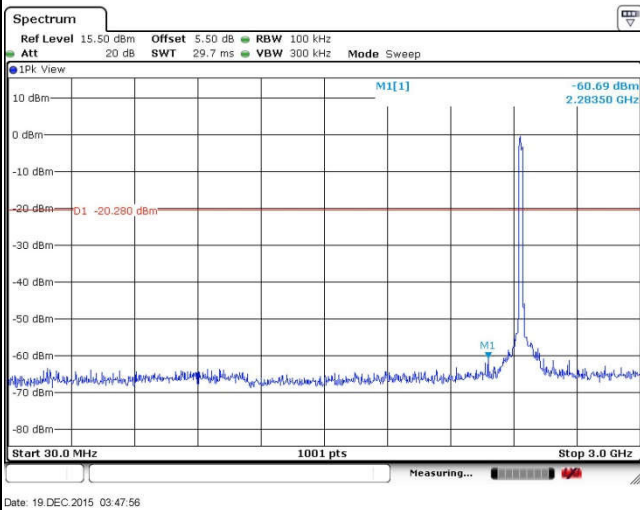

Spurious Emission 2GHz~25GHz

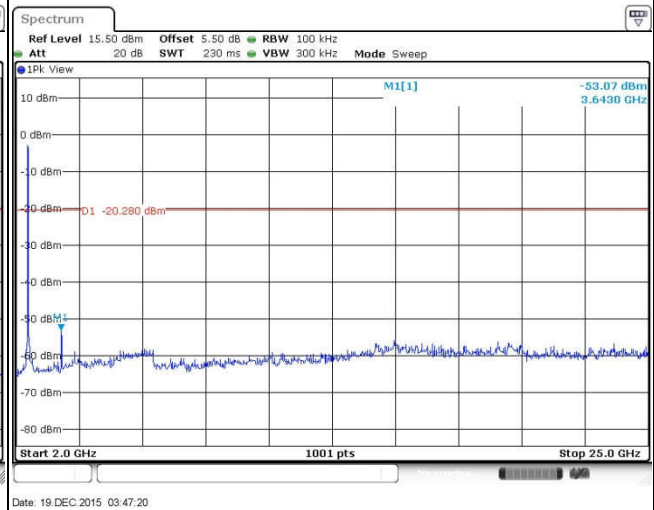



| | | | |
|----------------|--------------|---------------------|------------|
| Test Mode : | 802.11n HT20 | Temperature : | 24~25°C |
| Test Band : | 2.4GHz High | Relative Humidity : | 49~51% |
| Test Channel : | 11 | Test Engineer : | Issac Song |

WLAN 802.11n HT20 Channel 11

100kHz PSD reference Level

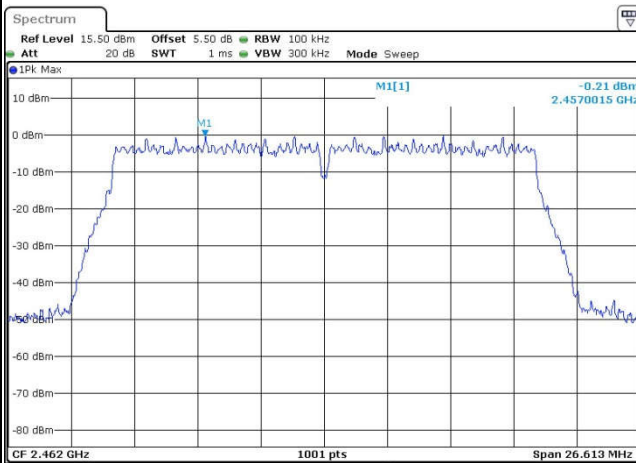

Date: 19 DEC.2015 03:51:59

High Channel Plot

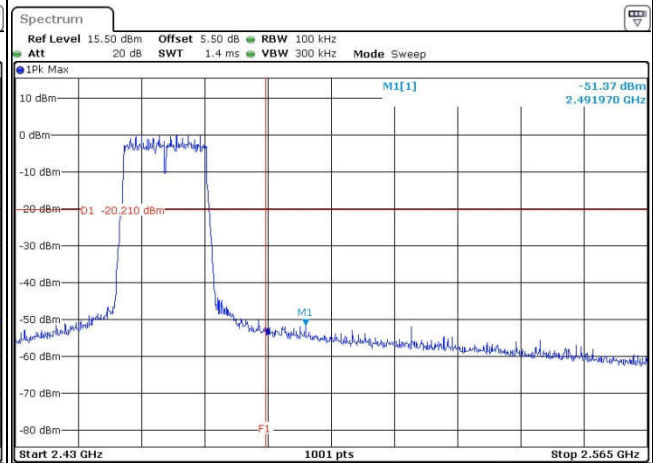

Date: 19 DEC.2015 03:52:20

Spurious Emission 30MHz~3GHz

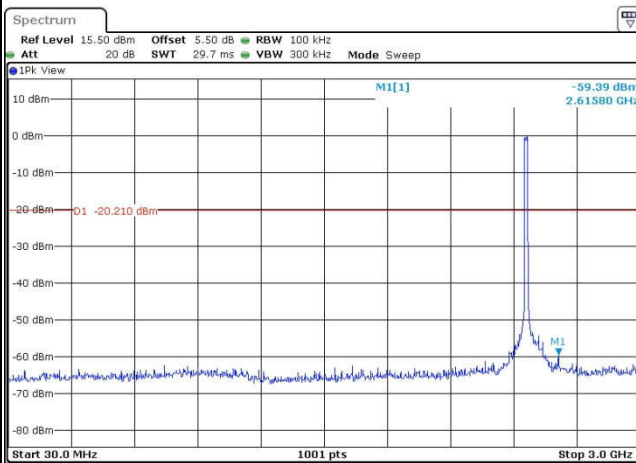

Date: 19 DEC.2015 03:58:04

Spurious Emission 2GHz~25GHz

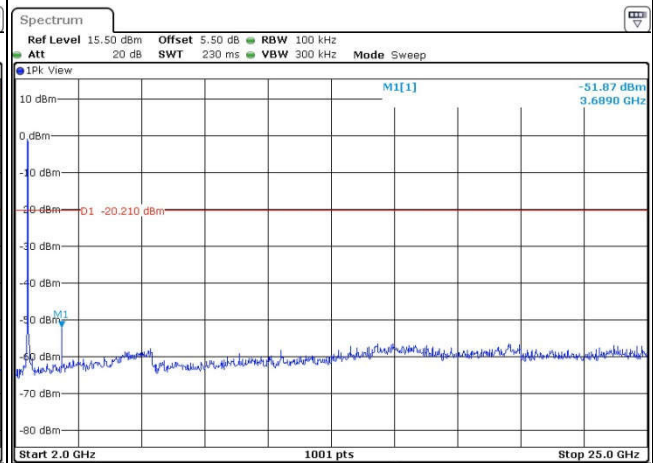

Date: 19 DEC.2015 03:58:12



| | | | |
|----------------|--------------|---------------------|------------|
| Test Mode : | 802.11n HT40 | Temperature : | 24~25°C |
| Test Band : | 2.4GHz Low | Relative Humidity : | 49~51% |
| Test Channel : | 03 | Test Engineer : | Issac Song |

WLAN 802.11n HT40 Channel 03

100kHz PSD reference Level

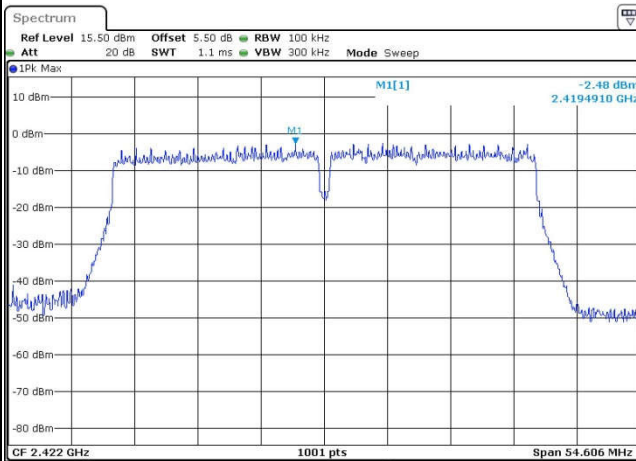

Date: 19 DEC. 2015 04:01:13

Low Channel Plot

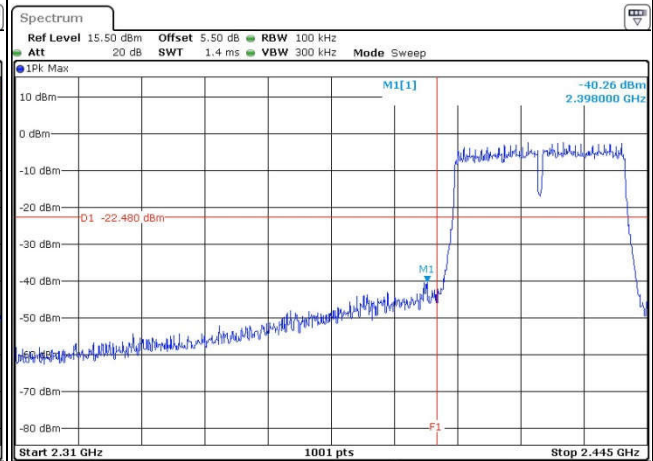

Date: 19 DEC. 2015 04:01:34

Spurious Emission 30MHz~3GHz

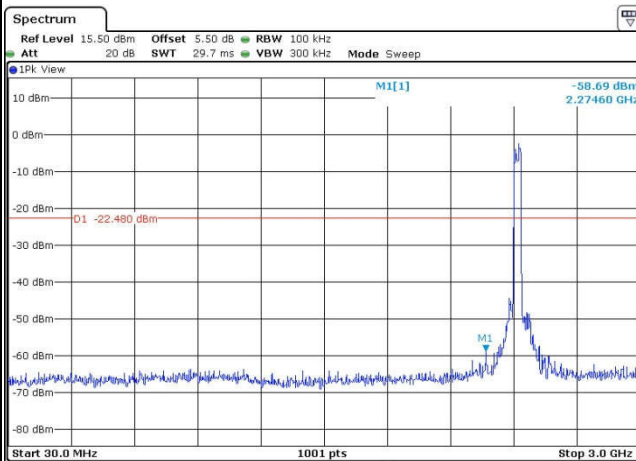

Date: 19 DEC. 2015 04:04:01

Spurious Emission 2GHz~25GHz

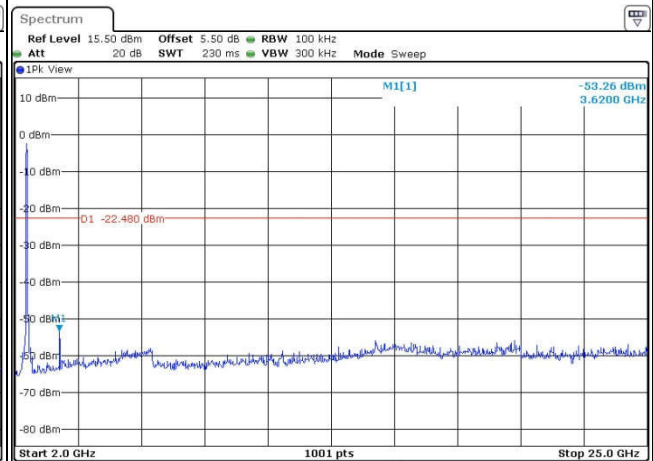

Date: 19 DEC. 2015 04:02:30



| | | | |
|----------------|--------------|---------------------|------------|
| Test Mode : | 802.11n HT40 | Temperature : | 24~25°C |
| Test Band : | 2.4GHz Mid | Relative Humidity : | 49~51% |
| Test Channel : | 06 | Test Engineer : | Issac Song |

WLAN 802.11n HT40 Channel 06

100kHz PSD reference Level

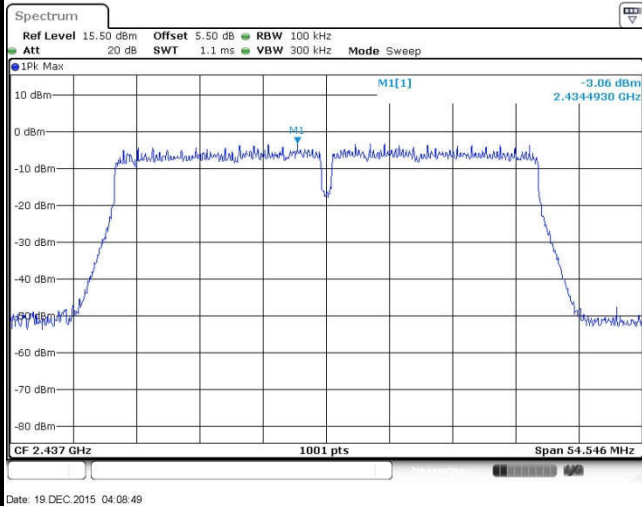

Spurious Emission 30MHz~3GHz

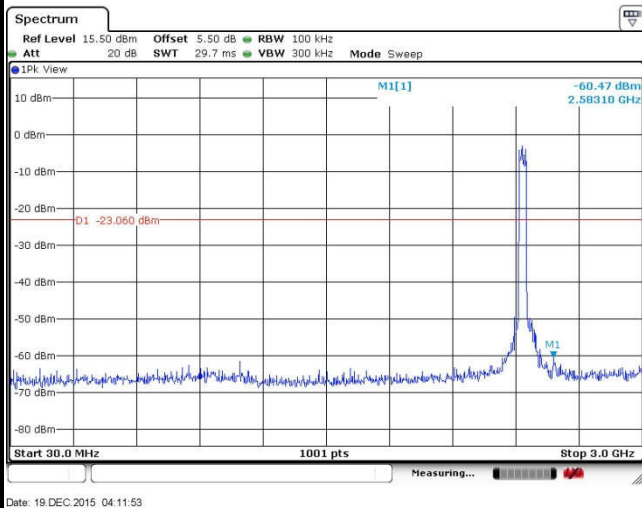

Spurious Emission 2GHz~25GHz

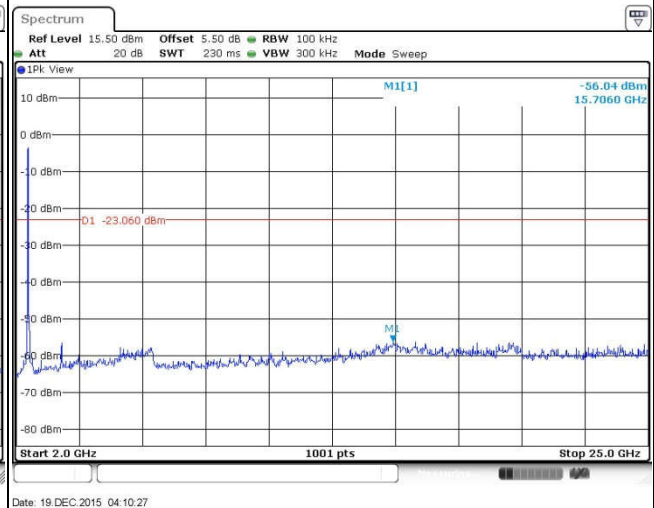



| | | | |
|----------------|--------------|---------------------|------------|
| Test Mode : | 802.11n HT40 | Temperature : | 24~25°C |
| Test Band : | 2.4GHz High | Relative Humidity : | 49~51% |
| Test Channel : | 09 | Test Engineer : | Issac Song |

WLAN 802.11n HT40 Channel 09

100kHz PSD reference Level

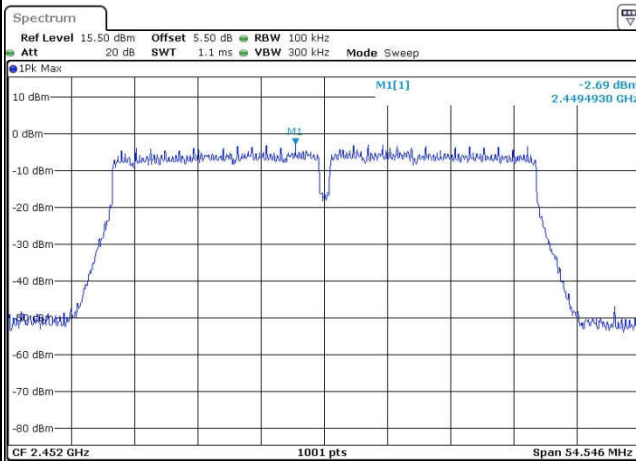

Date: 19 DEC.2015 04:18:07

High Channel Plot

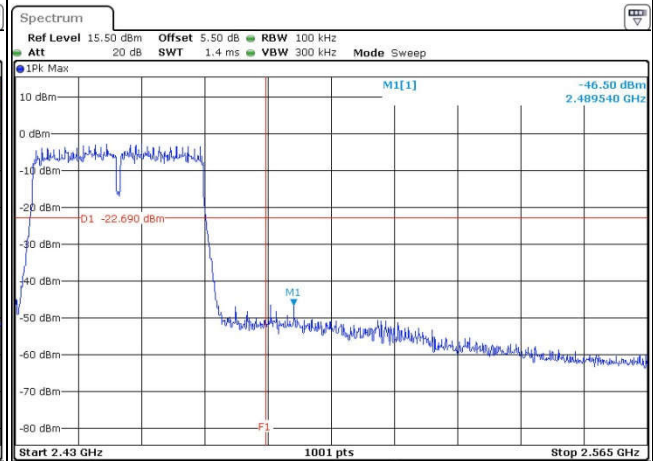

Date: 19 DEC.2015 04:18:19

Spurious Emission 30MHz~3GHz

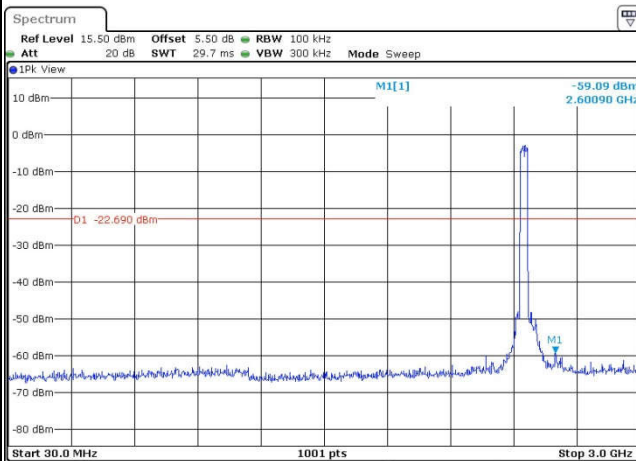

Date: 19 DEC.2015 04:18:48

Spurious Emission 2GHz~25GHz

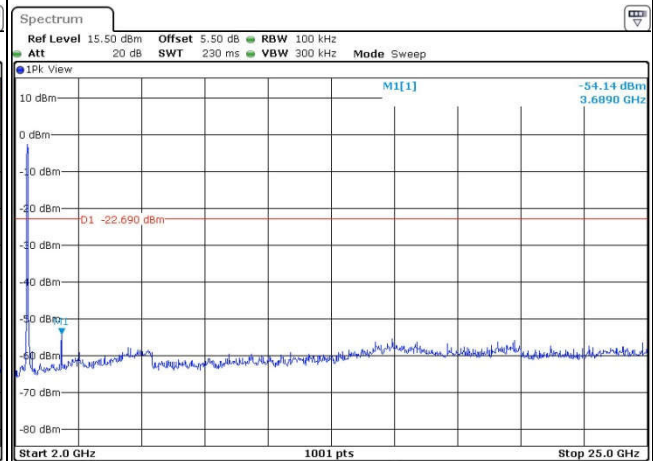

Date: 19 DEC.2015 04:18:57



3.5 Radiated Band Edges and Spurious Emission Measurement

3.5.1 Limit of Radiated band edge and Spurious Emission Measurement

In any 100 kHz bandwidth outside the intentional radiator frequency band, all harmonics/spurious must be at least 20 dB below the highest emission level within the authorized band. If the output power of this device was measured by spectrum analyzer, the attenuation under this paragraph shall be 30 dB instead of 20 dB. In addition, radiated emissions which fall in the restricted bands must also comply with the FCC section 15.209 limits as below.

| Frequency (MHz) | Field Strength (microvolts/meter) | Measurement Distance (meters) |
|-----------------|-----------------------------------|-------------------------------|
| 0.009 – 0.490 | 2400/F(kHz) | 300 |
| 0.490 – 1.705 | 24000/F(kHz) | 30 |
| 1.705 – 30.0 | 30 | 30 |
| 30 – 88 | 100 | 3 |
| 88 – 216 | 150 | 3 |
| 216 - 960 | 200 | 3 |
| Above 960 | 500 | 3 |

3.5.2 Measuring Instruments

The measuring equipment is listed in the section 4 of this test report.



3.5.3 Test Procedures

1. The testing follows FCC KDB Publication No. 558074 D01 DTS Meas. Guidance v03r03.
2. The EUT was arranged to its worst case and then tune the antenna tower (from 1 m to 4 m) and turntable (from 0 degree to 360 degrees) to find the maximum reading. A pre-amp and a high pass filter are used for the test in order to get better signal level.
3. The EUT was placed on a turntable with 0.8 meter for frequency below 1GHz and 1.5 meter for frequency above 1GHz respectively above ground.
4. The EUT was set 3 meters from the interference receiving antenna, which was mounted on the top of a variable height antenna tower.
5. Corrected Reading: Antenna Factor + Cable Loss + Read Level - Preamp Factor = Level
6. For measurement below 1GHz, If the emission level of the EUT measured by the peak detector is 3 dB lower than the applicable limit, the peak emission level will be reported. Otherwise, the emission measurement will be repeated using the quasi-peak detector and reported.
7. Use the following spectrum analyzer settings:
 - (1) Span shall wide enough to fully capture the emission being measured;
 - (2) Set RBW=100 kHz for $f < 1$ GHz; $VBW \geq RBW$; Sweep = auto; Detector function = peak; Trace = max hold;
 - (3) Set RBW = 1 MHz, VBW= 3MHz for $f \geq 1$ GHz for peak measurement.

For average measurement:

 - $VBW = 10$ Hz, when duty cycle is no less than 98 percent.
 - $VBW \geq 1/T$, when duty cycle is less than 98 percent where T is the minimum transmission duration over which the transmitter is on and is transmitting at its maximum power control level for the tested mode of operation.

| Band | Duty Cycle(%) | T(ms) | 1/T(kHz) | VBW Setting |
|---------------------|---------------|-------|----------|-------------|
| 802.11b | 99.05 | - | - | 10Hz |
| 802.11g | 82.98 | 0.18 | 5.70 | 10kHz |
| 2.4GHz 802.11n HT20 | 81.82 | 0.16 | 6.17 | 10kHz |
| 2.4GHz 802.11n HT40 | 72.59 | 0.10 | 10.20 | 11kHz |

3.5.4 Test Setup

For radiated emissions below 30MHz

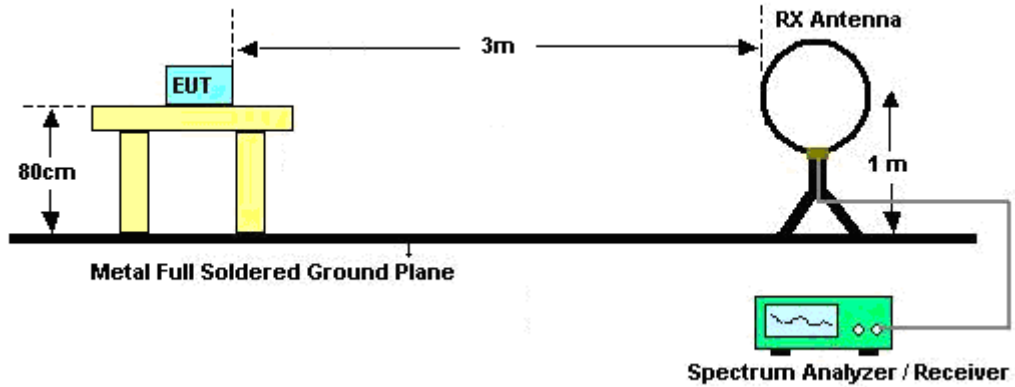

For radiated emissions from 30MHz to 1GHz

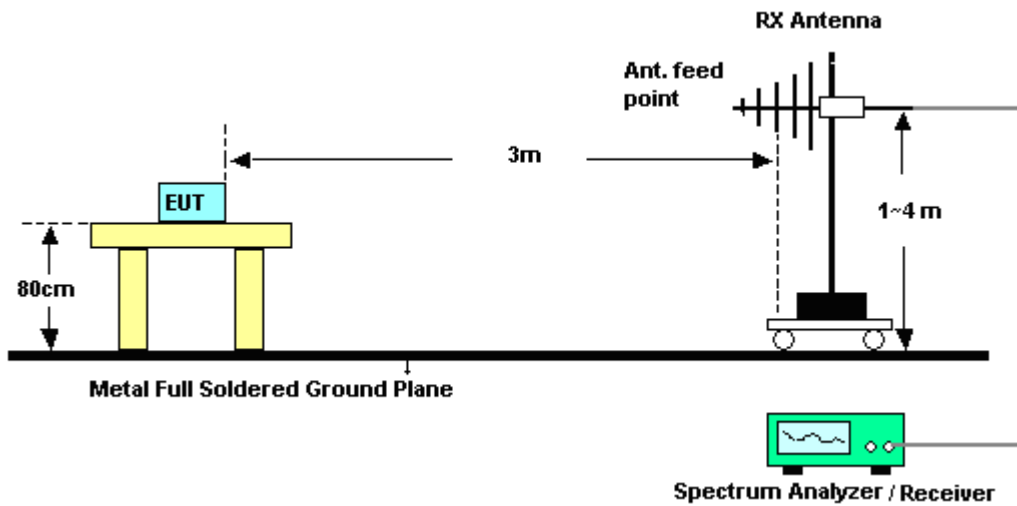

For radiated emissions above 1GHz

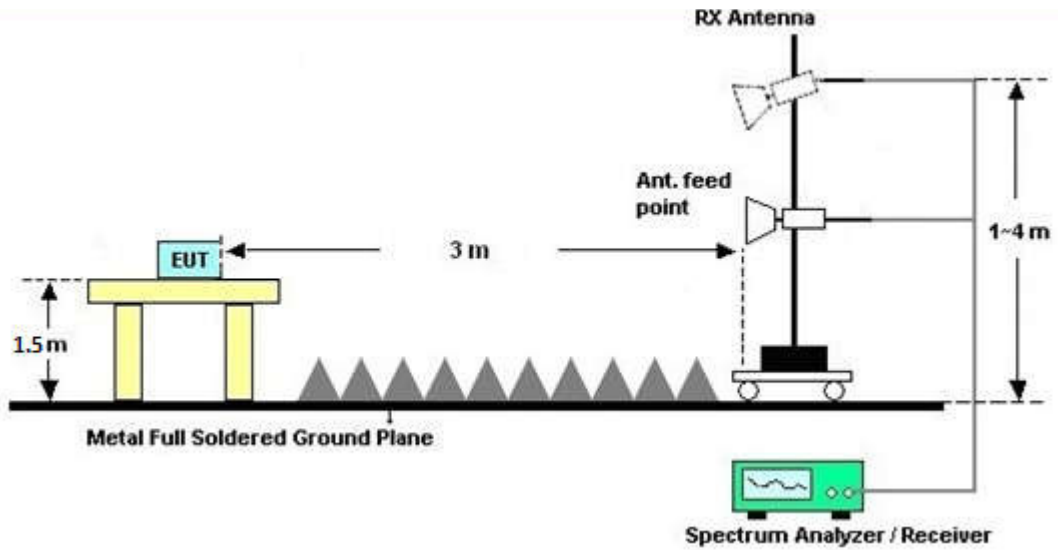

3.5.5 Test Results of Radiated Spurious Emissions (9kHz ~ 30MHz)

The low frequency, which started from 9 kHz to 30MHz, was pre-scanned and the result which was 20dB lower than the limit line per 15.31(o) was not reported.

3.5.6 Test Result of Radiated Spurious at Band Edges

Please refer to Appendix B.



3.5.7 Duty Cycle Plot

802.11b

Data Rate: 1Mbps

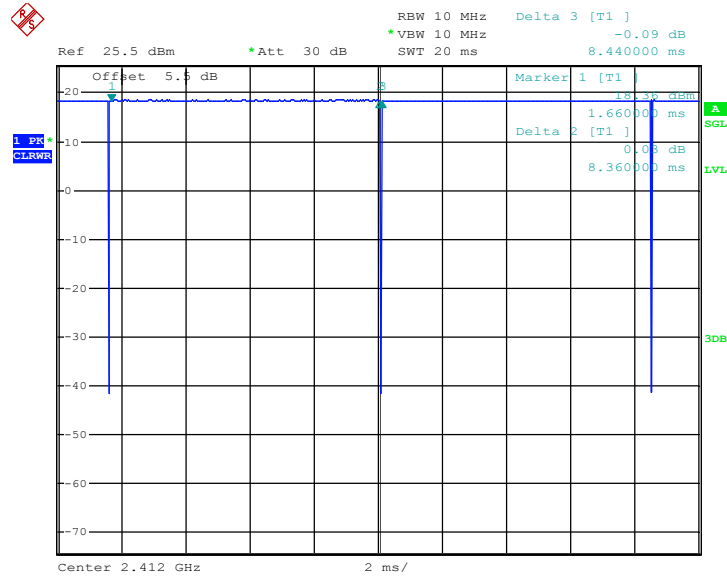

Date: 5.DEC.2015 00:46:24



802.11g

Data Rate: 54Mbps

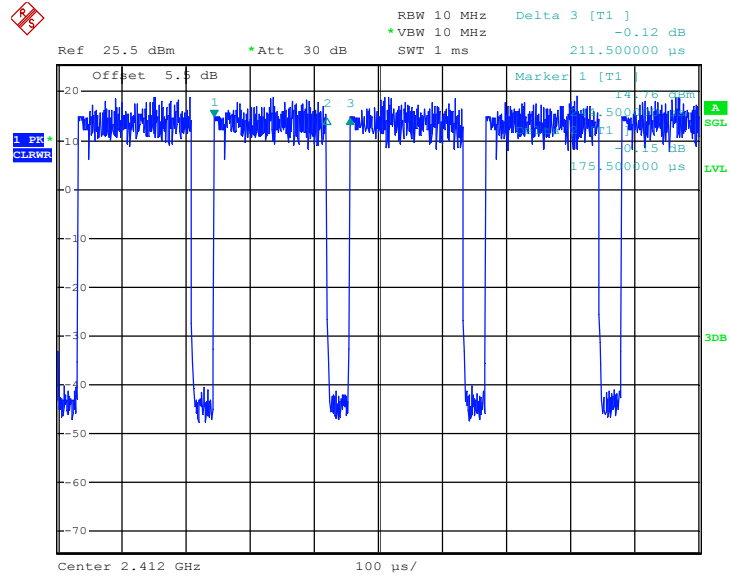

Date: 5.DEC.2015 00:54:38



802.11n HT20

Data Rate: MCS7

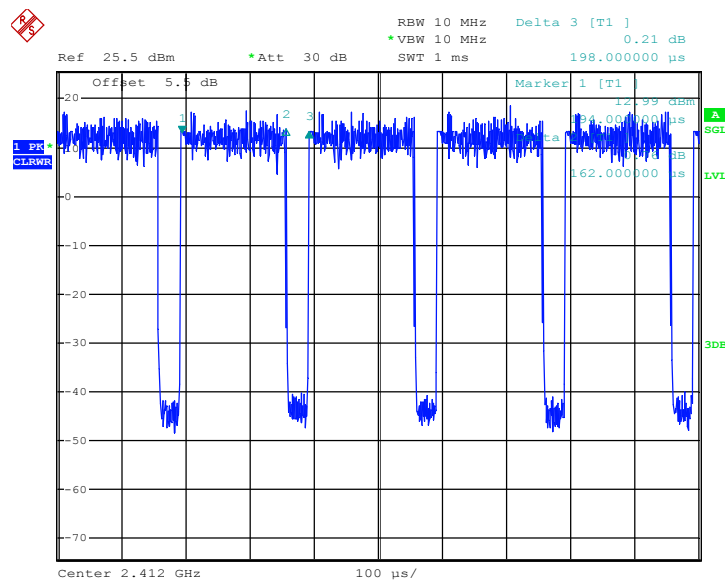

Date: 5.DEC.2015 00:59:59



802.11n HT40

Data Rate: MCS7

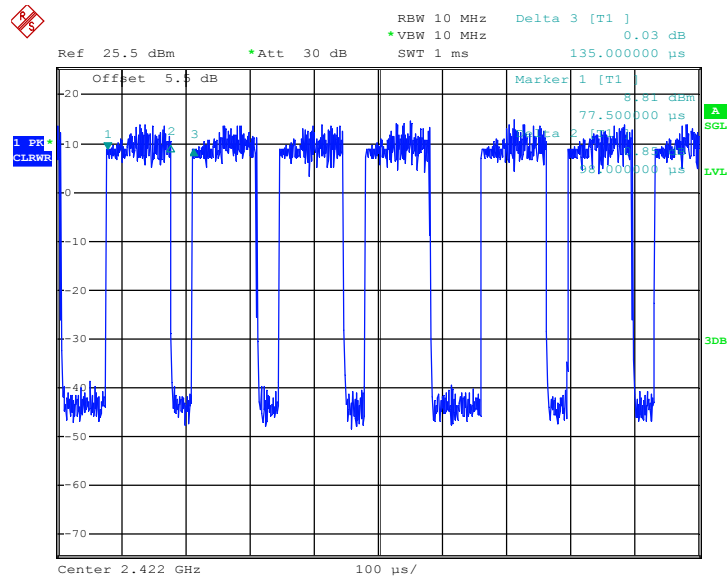

Date: 5.DEC.2015 01:09:22

3.5.8 Test Result of Radiated Spurious Emission (30MHz ~ 10th Harmonic)

Please refer to Appendix B.



3.6 AC Conducted Emission Measurement

3.6.1 Limit of AC Conducted Emission

For equipment that is designed to be connected to the public utility (AC) power line, the radio frequency voltage that is conducted back onto the AC power line on any frequency or frequencies within the band 150 kHz to 30 MHz shall not exceed the limits in the following table.

| Frequency of Emission (MHz) | Conducted Limit (dB μ V) | |
|--------------------------------|------------------------------|-----------|
| | Quasi-Peak | Average |
| 0.15-0.5 | 66 to 56* | 56 to 46* |
| 0.5-5 | 56 | 46 |
| 5-30 | 60 | 50 |

*Decreases with the logarithm of the frequency.

3.6.2 Measuring Instruments

The measuring equipment is listed in the section 4 of this test report.

3.6.3 Test Procedures

1. The EUT was placed 0.4 meter from the conducting wall of the shielding room, and it was kept at least 80 centimeters from any other grounded conducting surface.
2. Connect EUT to the power mains through a line impedance stabilization network (LISN).
3. All the support units are connecting to the other LISN.
4. The LISN provides 50 ohm coupling impedance for the measuring instrument.
5. The FCC states that a 50 ohm, 50 microhenry LISN should be used.
6. Both sides of AC line were checked for maximum conducted interference.
7. The frequency range from 150 kHz to 30 MHz was searched.
8. Set the test-receiver system to Peak Detect Function and specified bandwidth (IF bandwidth = 9kHz) with Maximum Hold Mode.

3.6.4 Test Setup

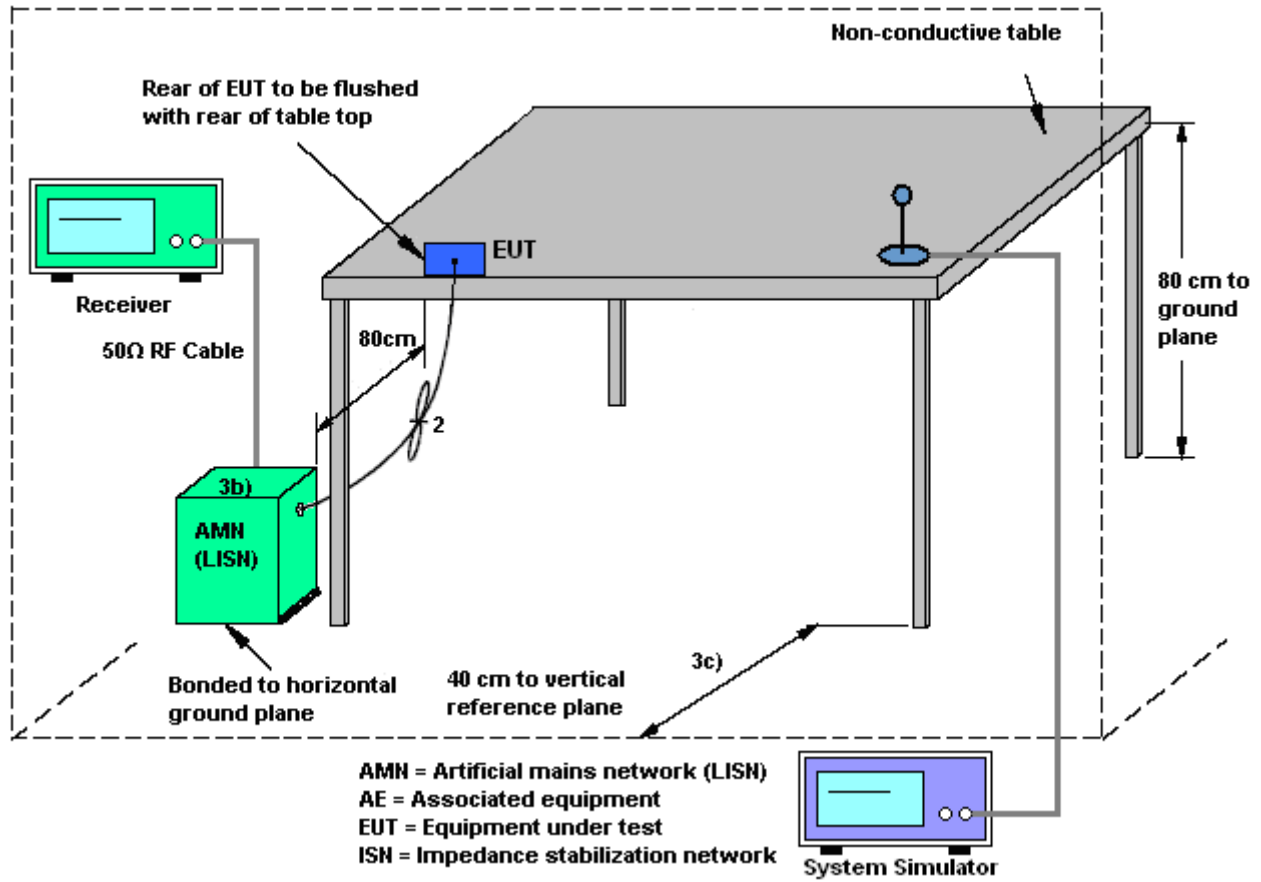



3.6.5 Test Result of AC Conducted Emission

| | | | |
|-----------------|---|---------------------|---------|
| Test Mode : | Mode 1 | Temperature : | 22~24°C |
| Test Engineer : | Amos Zhang | Relative Humidity : | 43~45% |
| Test Voltage : | 120Vac / 60Hz | Phase : | Line |
| Function Type : | GSM850 Idle + Bluetooth Link + WLAN Link + Earphone + USB Cable (Charging from Adapter) | | |

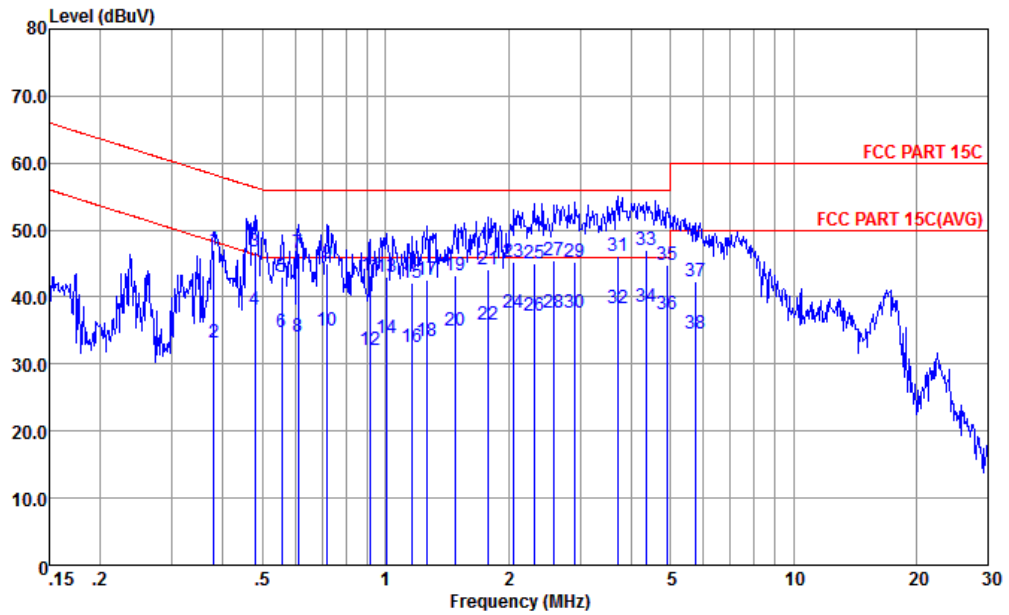

Site : CO01-kS
 Condition : FCC PART 15C LISN-L-20151024 LINE

| | Freq | Level | Over | Limit | Read | LISN | Cable | |
|----|------|-------|--------|-------|-------|--------|-------|---------|
| | MHz | dBuV | Limit | Line | Level | Factor | Loss | Remark |
| | | | dB | dBuV | dBuV | dB | dB | |
| 1 | 0.38 | 47.10 | -11.20 | 58.30 | 36.70 | 0.23 | 10.17 | QP |
| 2 | 0.38 | 33.30 | -15.00 | 48.30 | 22.90 | 0.23 | 10.17 | Average |
| 3 | 0.48 | 46.69 | -9.67 | 56.36 | 36.30 | 0.23 | 10.16 | QP |
| 4 | 0.48 | 38.19 | -8.17 | 46.36 | 27.80 | 0.23 | 10.16 | Average |
| 5 | 0.56 | 42.99 | -13.01 | 56.00 | 32.60 | 0.23 | 10.16 | QP |
| 6 | 0.56 | 34.69 | -11.31 | 46.00 | 24.30 | 0.23 | 10.16 | Average |
| 7 | 0.61 | 46.59 | -9.41 | 56.00 | 36.19 | 0.24 | 10.16 | QP |
| 8 | 0.61 | 34.19 | -11.81 | 46.00 | 23.79 | 0.24 | 10.16 | Average |
| 9 | 0.72 | 44.99 | -11.01 | 56.00 | 34.60 | 0.24 | 10.15 | QP |
| 10 | 0.72 | 34.89 | -11.11 | 46.00 | 24.50 | 0.24 | 10.15 | Average |
| 11 | 0.92 | 43.19 | -12.81 | 56.00 | 32.80 | 0.25 | 10.14 | QP |
| 12 | 0.92 | 31.99 | -14.01 | 46.00 | 21.60 | 0.25 | 10.14 | Average |
| 13 | 1.00 | 42.99 | -13.01 | 56.00 | 32.60 | 0.25 | 10.14 | QP |
| 14 | 1.00 | 33.89 | -12.11 | 46.00 | 23.50 | 0.25 | 10.14 | Average |
| 15 | 1.17 | 42.07 | -13.93 | 56.00 | 31.70 | 0.23 | 10.14 | QP |
| 16 | 1.17 | 32.57 | -13.43 | 46.00 | 22.20 | 0.23 | 10.14 | Average |
| 17 | 1.27 | 42.46 | -13.54 | 56.00 | 32.09 | 0.23 | 10.14 | QP |



| | | | |
|-----------------|---|---------------------|---------|
| Test Mode : | Mode 1 | Temperature : | 22~24°C |
| Test Engineer : | Amos Zhang | Relative Humidity : | 43~45% |
| Test Voltage : | 120Vac / 60Hz | Phase : | Line |
| Function Type : | GSM850 Idle + Bluetooth Link + WLAN Link + Earphone + USB Cable (Charging from Adapter) | | |

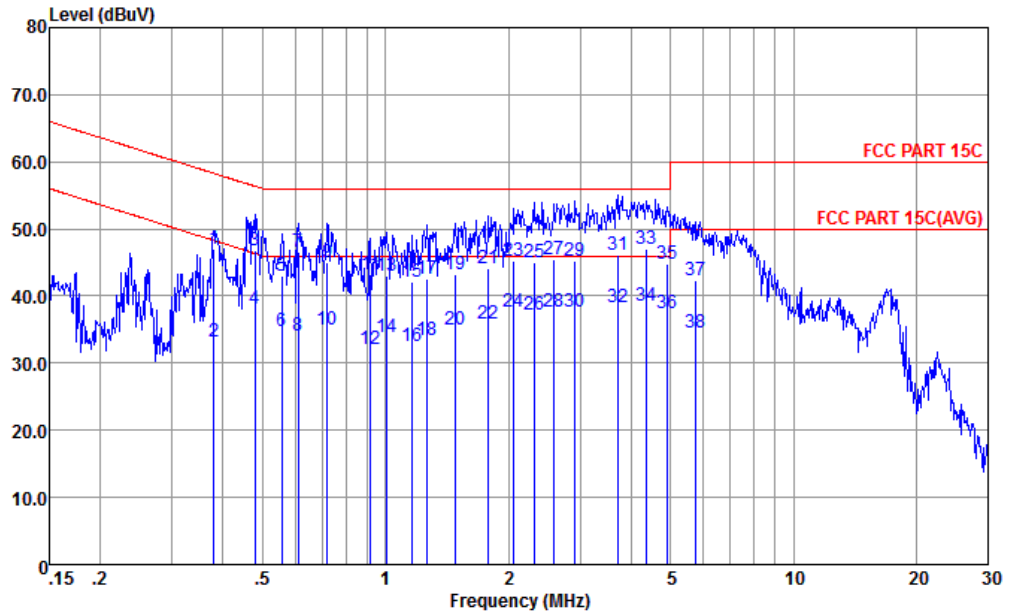

Site : CO01-kS
 Condition : FCC PART 15C LISN-L-20151024 LINE

| | Freq | Level | Over Limit | Limit Line | Read Level | LISN Factor | Cable Loss | Remark |
|------|------|-------|------------|------------|------------|-------------|------------|---------|
| | MHz | dBuV | dB | dBuV | dBuV | dB | dB | |
| 18 | 1.27 | 33.46 | -12.54 | 46.00 | 23.09 | 0.23 | 10.14 | Average |
| 19 | 1.48 | 43.25 | -12.75 | 56.00 | 32.90 | 0.21 | 10.14 | QP |
| 20 | 1.48 | 34.95 | -11.05 | 46.00 | 24.60 | 0.21 | 10.14 | Average |
| 21 | 1.79 | 44.23 | -11.77 | 56.00 | 33.90 | 0.19 | 10.14 | QP |
| 22 | 1.79 | 35.83 | -10.17 | 46.00 | 25.50 | 0.19 | 10.14 | Average |
| 23 | 2.07 | 45.22 | -10.78 | 56.00 | 34.90 | 0.18 | 10.14 | QP |
| 24 | 2.07 | 37.72 | -8.28 | 46.00 | 27.40 | 0.18 | 10.14 | Average |
| 25 | 2.31 | 44.93 | -11.07 | 56.00 | 34.60 | 0.18 | 10.15 | QP |
| 26 | 2.31 | 37.13 | -8.87 | 46.00 | 26.80 | 0.18 | 10.15 | Average |
| 27 | 2.59 | 45.43 | -10.57 | 56.00 | 35.10 | 0.18 | 10.15 | QP |
| 28 | 2.59 | 37.73 | -8.27 | 46.00 | 27.40 | 0.18 | 10.15 | Average |
| 29 | 2.92 | 45.24 | -10.76 | 56.00 | 34.91 | 0.18 | 10.15 | QP |
| 30 | 2.92 | 37.74 | -8.26 | 46.00 | 27.41 | 0.18 | 10.15 | Average |
| 31 | 3.70 | 46.15 | -9.85 | 56.00 | 35.80 | 0.19 | 10.16 | QP |
| 32 | 3.70 | 38.25 | -7.75 | 46.00 | 27.90 | 0.19 | 10.16 | Average |
| 33 | 4.36 | 47.06 | -8.94 | 56.00 | 36.70 | 0.19 | 10.17 | QP |
| 34 * | 4.36 | 38.66 | -7.34 | 46.00 | 28.30 | 0.19 | 10.17 | Average |
| 35 | 4.90 | 44.87 | -11.13 | 56.00 | 34.50 | 0.19 | 10.18 | QP |
| 36 | 4.90 | 37.47 | -8.53 | 46.00 | 27.10 | 0.19 | 10.18 | Average |
| 37 | 5.77 | 42.30 | -17.70 | 60.00 | 31.89 | 0.21 | 10.20 | QP |
| 38 | 5.77 | 34.60 | -15.40 | 50.00 | 24.19 | 0.21 | 10.20 | Average |



| | | | |
|-----------------|---|---------------------|---------|
| Test Mode : | Mode 1 | Temperature : | 22~24°C |
| Test Engineer : | Amos Zhang | Relative Humidity : | 43~45% |
| Test Voltage : | 120Vac / 60Hz | Phase : | Neutral |
| Function Type : | GSM850 Idle + Bluetooth Link + WLAN Link + Earphone + USB Cable (Charging from Adapter) | | |

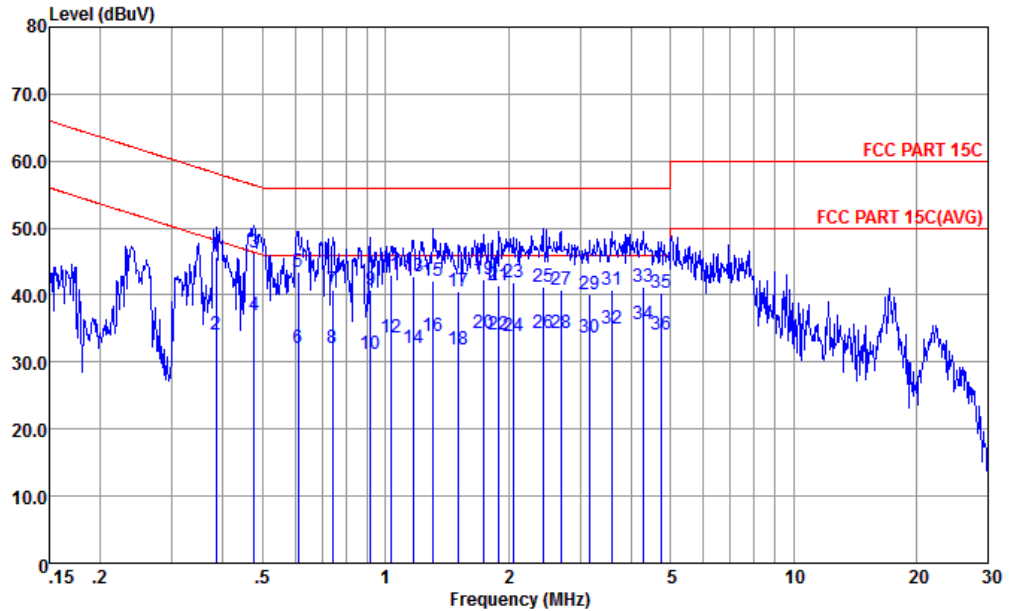

Site : CO01-kS
 Condition : FCC PART 15C LISN-N-20151024 NEUTRAL

| | Freq | Level | Over Limit | Limit Line | Read Level | LISN Factor | Cable Loss | Remark |
|-----|------|-------|------------|------------|------------|-------------|------------|---------|
| | MHz | dBuV | dB | dBuV | dBuV | dB | dB | |
| 1 | 0.39 | 45.69 | -12.48 | 58.17 | 35.20 | 0.32 | 10.17 | QP |
| 2 | 0.39 | 34.09 | -14.08 | 48.17 | 23.60 | 0.32 | 10.17 | Average |
| 3 | 0.48 | 46.38 | -10.03 | 56.41 | 35.90 | 0.32 | 10.16 | QP |
| 4 * | 0.48 | 36.98 | -9.43 | 46.41 | 26.50 | 0.32 | 10.16 | Average |
| 5 | 0.61 | 43.39 | -12.61 | 56.00 | 32.90 | 0.33 | 10.16 | QP |
| 6 | 0.61 | 32.09 | -13.91 | 46.00 | 21.60 | 0.33 | 10.16 | Average |
| 7 | 0.74 | 40.79 | -15.21 | 56.00 | 30.30 | 0.34 | 10.15 | QP |
| 8 | 0.74 | 32.09 | -13.91 | 46.00 | 21.60 | 0.34 | 10.15 | Average |
| 9 | 0.92 | 40.80 | -15.20 | 56.00 | 30.30 | 0.36 | 10.14 | QP |
| 10 | 0.92 | 31.30 | -14.70 | 46.00 | 20.80 | 0.36 | 10.14 | Average |
| 11 | 1.03 | 43.01 | -12.99 | 56.00 | 32.50 | 0.37 | 10.14 | QP |
| 12 | 1.03 | 33.61 | -12.39 | 46.00 | 23.10 | 0.37 | 10.14 | Average |
| 13 | 1.17 | 42.81 | -13.19 | 56.00 | 32.30 | 0.37 | 10.14 | QP |
| 14 | 1.17 | 32.11 | -13.89 | 46.00 | 21.60 | 0.37 | 10.14 | Average |
| 15 | 1.31 | 42.11 | -13.89 | 56.00 | 31.60 | 0.37 | 10.14 | QP |
| 16 | 1.31 | 33.81 | -12.19 | 46.00 | 23.30 | 0.37 | 10.14 | Average |
| 17 | 1.51 | 40.62 | -15.38 | 56.00 | 30.10 | 0.38 | 10.14 | QP |



| | | | |
|-----------------|---|---------------------|---------|
| Test Mode : | Mode 1 | Temperature : | 22~24°C |
| Test Engineer : | Amos Zhang | Relative Humidity : | 43~45% |
| Test Voltage : | 120Vac / 60Hz | Phase : | Neutral |
| Function Type : | GSM850 Idle + Bluetooth Link + WLAN Link + Earphone + USB Cable (Charging from Adapter) | | |

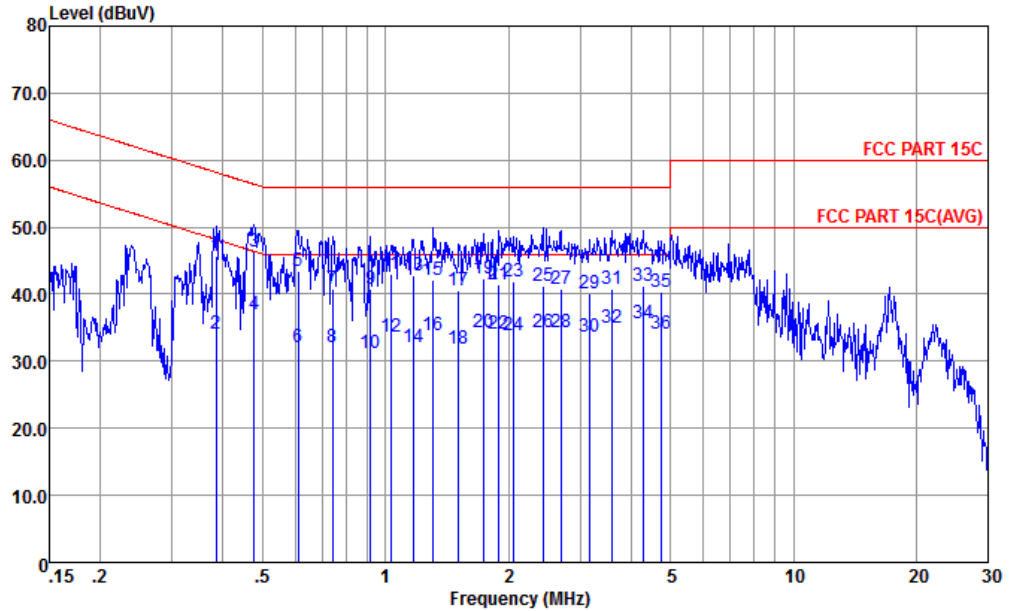

Site : CO01-kS
 Condition : FCC PART 15C LISN-N-20151024 NEUTRAL

| | Freq | Level | Over Limit | Limit Line | Read Level | LISN Factor | Cable Loss | Remark |
|----|------|-------|------------|------------|------------|-------------|------------|---------|
| | MHz | dBuV | dB | dBuV | dBuV | dB | dB | |
| 18 | 1.51 | 31.92 | -14.08 | 46.00 | 21.40 | 0.38 | 10.14 | Average |
| 19 | 1.73 | 42.42 | -13.58 | 56.00 | 31.90 | 0.38 | 10.14 | QP |
| 20 | 1.73 | 34.32 | -11.68 | 46.00 | 23.80 | 0.38 | 10.14 | Average |
| 21 | 1.90 | 41.42 | -14.58 | 56.00 | 30.90 | 0.38 | 10.14 | QP |
| 22 | 1.90 | 34.12 | -11.88 | 46.00 | 23.60 | 0.38 | 10.14 | Average |
| 23 | 2.05 | 41.82 | -14.18 | 56.00 | 31.30 | 0.38 | 10.14 | QP |
| 24 | 2.05 | 33.82 | -12.18 | 46.00 | 23.30 | 0.38 | 10.14 | Average |
| 25 | 2.43 | 41.12 | -14.88 | 56.00 | 30.59 | 0.38 | 10.15 | QP |
| 26 | 2.43 | 34.42 | -11.58 | 46.00 | 23.89 | 0.38 | 10.15 | Average |
| 27 | 2.69 | 40.82 | -15.18 | 56.00 | 30.30 | 0.37 | 10.15 | QP |
| 28 | 2.69 | 34.22 | -11.78 | 46.00 | 23.70 | 0.37 | 10.15 | Average |
| 29 | 3.16 | 40.13 | -15.87 | 56.00 | 29.60 | 0.37 | 10.16 | QP |
| 30 | 3.16 | 33.73 | -12.27 | 46.00 | 23.20 | 0.37 | 10.16 | Average |
| 31 | 3.58 | 40.83 | -15.17 | 56.00 | 30.30 | 0.37 | 10.16 | QP |
| 32 | 3.58 | 35.03 | -10.97 | 46.00 | 24.50 | 0.37 | 10.16 | Average |
| 33 | 4.27 | 41.13 | -14.87 | 56.00 | 30.60 | 0.36 | 10.17 | QP |
| 34 | 4.27 | 35.63 | -10.37 | 46.00 | 25.10 | 0.36 | 10.17 | Average |
| 35 | 4.75 | 40.34 | -15.66 | 56.00 | 29.80 | 0.36 | 10.18 | QP |
| 36 | 4.75 | 34.14 | -11.86 | 46.00 | 23.60 | 0.36 | 10.18 | Average |



3.7 Antenna Requirements

3.7.1 Standard Applicable

If directional gain of transmitting antennas is greater than 6dBi, the power shall be reduced by the same level in dB comparing to gain minus 6dBi. For the fixed point-to-point operation, the power shall be reduced by one dB for every 3 dB that the directional gain of the antenna exceeds 6 dBi. The use of a permanently attached antenna or of an antenna that uses a unique coupling to the intentional radiator shall be considered sufficient to comply with the FCC rule.

3.7.2 Antenna Anti-Replacement Construction

An embedded-in antenna design is used.

3.7.3 Antenna Gain

The antenna peak gain of EUT is less than 6 dBi. Therefore, it is not necessary to reduce maximum peak output power limit.



4 List of Measuring Equipment

| Instrument | Manufacturer | Model No. | Serial No. | Characteristics | Calibration Date | Test Date | Due Date | Remark |
|-----------------------------------|--------------|-----------|-------------|-------------------------|------------------|---------------------------------|---------------|-----------------------|
| Spectrum Analyzer | R&S | FSV30 | 101338 | 9kHz~30GHz | May 04, 2015 | Dec. 08, 2015~ Jan. 19, 2016 | May 03, 2016 | Conducted (TH01-KS) |
| Pulse Power Senor | Anritsu | MA2411B | 0917070 | 30MHz~40GHz | Jan. 23, 2015 | Dec. 08, 2015~ Jan. 19, 2016 | Jan. 22, 2016 | Conducted (TH01-KS) |
| Power Meter | Anritsu | ML2495A | 1005002 | 50MHz Bandwidth | Jan. 23, 2015 | Dec. 08, 2015~ Jan. 19, 2016 | Jan. 22, 2016 | Conducted (TH01-KS) |
| EMI Test Receiver | R&S | ESR7 | 101403 | 9kHz~7GHz;Ma x 30dBm | Sep. 10, 2015 | Dec. 05, 2015~ Dec. 23, 2015 | Sep. 09, 2016 | Radiation (03CH03-KS) |
| EXA Spectrum Analyzer | Keysight | N9010A | MY55150244 | 10Hz-44GHz | Jun. 05, 2015 | Dec. 05, 2015~ Dec. 23, 2015 | Jun. 04, 2016 | Radiation (03CH03-KS) |
| Loop Antenna | R&S | HFH2-Z2 | 100321 | 9kHz~30MHz | Nov. 10, 2015 | Dec. 05, 2015~ Dec. 23, 2015 | Nov. 09, 2016 | Radiation (03CH03-KS) |
| Bilog Antenna | TeseQ | CBL6112D | 35406 | 25MHz-2GHz | Jun. 25, 2015 | Dec. 05, 2015~ Dec. 23, 2015 | Jun. 24, 2016 | Radiation (03CH03-KS) |
| Horn Antenna | Schwarzbeck | BBHA9120D | 9120D-1356 | 1GHz~18GHz | Jun. 25, 2015 | Dec. 05, 2015~ Dec. 23, 2015 | Jun. 24, 2016 | Radiation (03CH03-KS) |
| SHF-EHF Horn | Schwarzbeck | BBHA 9170 | BBHA170249 | 15GHz ~40GHz | Mar. 03, 2015 | Dec. 05, 2015~ Dec. 23, 2015 | Mar. 02, 2016 | Radiation (03CH03-KS) |
| Amplifier | Burgeon | BPA-530 | 102212 | 0.01MHz-3000MHz | Aug. 10, 2015 | Dec. 05, 2015~ Dec. 23, 2015 | Aug. 09, 2016 | Radiation (03CH03-KS) |
| Amplifier | Agilent | 8449B | 3008A02370 | 1GHz~26.5GHz | Oct. 24, 2015 | Dec. 05, 2015~ Dec. 23, 2015 | Oct. 23, 2016 | Radiation (03CH03-KS) |
| AC Power Source | Chroma | 61601 | F104090004 | N/A | NCR | Dec. 05, 2015~ Dec. 23, 2015 | NCR | Radiation (03CH03-KS) |
| Turn Table | ChamPro | EM 1000-T | 060762-T | 0~360 degree | NCR | Dec. 05, 2015~ Dec. 23, 2015 | NCR | Radiation (03CH03-KS) |
| Antenna Mast | ChamPro | EM 1000-A | 060762-A | 1 m~4 m | NCR | Dec. 05, 2015~ Dec. 23, 2015 | NCR | Radiation (03CH03-KS) |
| EMI Test Receiver | R&S | ESR7 | 101403 | 9kHz~7GHz;Ma x 30dBm | Sep. 10, 2015 | Dec. 08, 2015 | Sep. 09, 2016 | Conduction (CO01-KS) |
| AC LISN | MessTec | AN3016 | 060103 | 9kHz~30MHz | Oct. 24, 2015 | Dec. 08, 2015 | Oct. 23, 2016 | Conduction (CO01-KS) |
| AC LISN (for auxiliary equipment) | MessTec | AN3016 | 060105 | 9kHz~30MHz | Oct. 24, 2015 | Dec. 08, 2015 | Oct. 23, 2016 | Conduction (CO01-KS) |
| AC Power Source | Chroma | 61602 | ABP00000811 | AC 0V~300V, 45Hz~1000Hz | Oct. 24, 2015 | Dec. 08, 2015 | Oct. 23, 2016 | Conduction (CO01-KS) |



5 Uncertainty of Evaluation

Uncertainty of Conducted Emission Measurement (150kHz ~ 30MHz)

| | |
|---|-------|
| Measuring Uncertainty for a Level of Confidence of 95% ($U = 2Uc(y)$) | 2.3dB |
|---|-------|

Uncertainty of Radiated Emission Measurement (30 MHz ~ 1000 MHz)

| | |
|---|-------|
| Measuring Uncertainty for a Level of Confidence of 95% ($U = 2Uc(y)$) | 4.5dB |
|---|-------|



Appendix A. Conducted Test Results

A1 - DTS Part

| | | | | |
|----------------|-----------------------|--------------------|-------|----|
| Test Engineer: | Issac Song | Temperature: | 24~25 | °C |
| Test Date: | 2015/12/8 ~ 2016/1/19 | Relative Humidity: | 49~51 | % |

TEST RESULTS DATA
6dB and 99% Occupied Bandwidth

| 2.4GHz Band | | | | | | | | |
|-------------|-----------|-----------------|-----|-------------|-----------------------|--------------|--------------------|-----------|
| Mod. | Data Rate | N _{TX} | CH. | Freq. (MHz) | 99% Occupied BW (MHz) | 6dB BW (MHz) | 6dB BW Limit (MHz) | Pass/Fail |
| 11b | 1Mbps | 1 | 1 | 2412 | 12.54 | 9.55 | 0.50 | Pass |
| 11b | 1Mbps | 1 | 6 | 2437 | 12.64 | 10.01 | 0.50 | Pass |
| 11b | 1Mbps | 1 | 11 | 2462 | 12.54 | 10.01 | 0.50 | Pass |
| 11g | 54Mbps | 1 | 1 | 2412 | 18.03 | 16.34 | 0.50 | Pass |
| 11g | 54Mbps | 1 | 2 | 2417 | 17.68 | 16.38 | 0.50 | Pass |
| 11g | 54Mbps | 1 | 6 | 2437 | 17.38 | 16.40 | 0.50 | Pass |
| 11g | 54Mbps | 1 | 10 | 2457 | 17.43 | 16.34 | 0.50 | Pass |
| 11g | 54Mbps | 1 | 11 | 2462 | 17.88 | 16.34 | 0.50 | Pass |
| HT20 | MCS7 | 1 | 1 | 2412 | 18.38 | 17.72 | 0.50 | Pass |
| HT20 | MCS7 | 1 | 6 | 2437 | 18.38 | 17.72 | 0.50 | Pass |
| HT20 | MCS7 | 1 | 11 | 2462 | 18.38 | 17.74 | 0.50 | Pass |
| HT40 | MCS7 | 1 | 3 | 2422 | 36.46 | 36.40 | 0.50 | Pass |
| HT40 | MCS7 | 1 | 6 | 2437 | 36.36 | 36.36 | 0.50 | Pass |
| HT40 | MCS7 | 1 | 9 | 2452 | 36.46 | 36.36 | 0.50 | Pass |

TEST RESULTS DATA
Peak Power Table

| 2.4GHz Band | | | | | | | | | | |
|-------------|-----------|-----------------|-----|-------------|----------------------------|-----------------------------|----------|------------------|------------------------|------------|
| Mod. | Data Rate | N _{TX} | CH. | Freq. (MHz) | Peak Conducted Power (dBm) | Conducted Power Limit (dBm) | DG (dBi) | EIRP Power (dBm) | EIRP Power Limit (dBm) | Pass /Fail |
| 11b | 1Mbps | 1 | 1 | 2412 | 18.26 | 30.00 | 0.05 | 18.31 | 36.00 | Pass |
| 11b | 1Mbps | 1 | 6 | 2437 | 18.82 | 30.00 | 0.05 | 18.87 | 36.00 | Pass |
| 11b | 1Mbps | 1 | 11 | 2462 | 18.18 | 30.00 | 0.05 | 18.23 | 36.00 | Pass |
| 11g | 54Mbps | 1 | 1 | 2412 | 19.81 | 30.00 | 0.05 | 19.86 | 36.00 | Pass |
| 11g | 54Mbps | 1 | 2 | 2417 | 22.59 | 30.00 | 0.05 | 22.64 | 36.00 | Pass |
| 11g | 54Mbps | 1 | 6 | 2437 | 22.18 | 30.00 | 0.05 | 22.23 | 36.00 | Pass |
| 11g | 54Mbps | 1 | 10 | 2457 | 22.54 | 30.00 | 0.05 | 22.59 | 36.00 | Pass |
| 11g | 54Mbps | 1 | 11 | 2462 | 20.04 | 30.00 | 0.05 | 20.09 | 36.00 | Pass |
| HT20 | MCS7 | 1 | 1 | 2412 | 21.46 | 30.00 | 0.05 | 21.51 | 36.00 | Pass |
| HT20 | MCS7 | 1 | 6 | 2437 | 21.12 | 30.00 | 0.05 | 21.17 | 36.00 | Pass |
| HT20 | MCS7 | 1 | 11 | 2462 | 21.38 | 30.00 | 0.05 | 21.43 | 36.00 | Pass |
| HT40 | MCS7 | 1 | 3 | 2422 | 21.77 | 30.00 | 0.05 | 21.82 | 36.00 | Pass |
| HT40 | MCS7 | 1 | 6 | 2437 | 21.34 | 30.00 | 0.05 | 21.39 | 36.00 | Pass |
| HT40 | MCS7 | 1 | 9 | 2452 | 21.52 | 30.00 | 0.05 | 21.57 | 36.00 | Pass |

TEST RESULTS DATA
Average Power Table
(Reporting Only)

| 2.4GHz Band | | | | | | |
|-------------|-----------|-----------------|-----|-------------|------------------|-------------------------------|
| Mod. | Data Rate | N _{TX} | CH. | Freq. (MHz) | Duty Factor (dB) | Average Conducted Power (dBm) |
| 11b | 1Mbps | 1 | 1 | 2412 | 0.04 | 15.33 |
| 11b | 1Mbps | 1 | 6 | 2437 | 0.04 | 16.05 |
| 11b | 1Mbps | 1 | 11 | 2462 | 0.04 | 15.19 |
| 11g | 54Mbps | 1 | 1 | 2412 | 0.12 | 9.72 |
| 11g | 54Mbps | 1 | 2 | 2417 | 0.12 | 12.88 |
| 11g | 54Mbps | 1 | 6 | 2437 | 0.12 | 12.08 |
| 11g | 54Mbps | 1 | 10 | 2457 | 0.12 | 12.66 |
| 11g | 54Mbps | 1 | 11 | 2462 | 0.12 | 9.85 |
| HT20 | MCS7 | 1 | 1 | 2412 | 0.12 | 10.76 |
| HT20 | MCS7 | 1 | 6 | 2437 | 0.12 | 10.35 |
| HT20 | MCS7 | 1 | 11 | 2462 | 0.12 | 10.56 |
| HT40 | MCS7 | 1 | 3 | 2422 | 0.23 | 10.77 |
| HT40 | MCS7 | 1 | 6 | 2437 | 0.23 | 10.13 |
| HT40 | MCS7 | 1 | 9 | 2452 | 0.23 | 10.44 |

TEST RESULTS DATA
Peak Power Density

| 2.4GHz Band | | | | | | | | |
|-------------|-----------|-----------------|-----|-------------|----------------------|----------|----------------------------|-----------|
| Mod. | Data Rate | N _{TX} | CH. | Freq. (MHz) | Peak PSD (dBm /3kHz) | DG (dBi) | Peak PSD Limit (dBm /3kHz) | Pass/Fail |
| 11b | 1Mbps | 1 | 1 | 2412 | -7.91 | 0.05 | 8.00 | Pass |
| 11b | 1Mbps | 1 | 6 | 2437 | -7.76 | 0.05 | 8.00 | Pass |
| 11b | 1Mbps | 1 | 11 | 2462 | -7.89 | 0.05 | 8.00 | Pass |
| 11g | 54Mbps | 1 | 1 | 2412 | -15.10 | 0.05 | 8.00 | Pass |
| 11g | 54Mbps | 1 | 2 | 2417 | -12.70 | 0.05 | 8.00 | Pass |
| 11g | 54Mbps | 1 | 6 | 2437 | -12.40 | 0.05 | 8.00 | Pass |
| 11g | 54Mbps | 1 | 10 | 2457 | -12.76 | 0.05 | 8.00 | Pass |
| 11g | 54Mbps | 1 | 11 | 2462 | -14.08 | 0.05 | 8.00 | Pass |
| HT20 | MCS7 | 1 | 1 | 2412 | -14.29 | 0.05 | 8.00 | Pass |
| HT20 | MCS7 | 1 | 6 | 2437 | -14.84 | 0.05 | 8.00 | Pass |
| HT20 | MCS7 | 1 | 11 | 2462 | -13.85 | 0.05 | 8.00 | Pass |
| HT40 | MCS7 | 1 | 3 | 2422 | -15.64 | 0.05 | 8.00 | Pass |
| HT40 | MCS7 | 1 | 6 | 2437 | -17.30 | 0.05 | 8.00 | Pass |
| HT40 | MCS7 | 1 | 9 | 2452 | -17.51 | 0.05 | 8.00 | Pass |



Appendix B. Radiated Spurious Emission

| WIFI | 2.4GHz 2400~2483.5MHz WIFI 802.11b (Band Edge @ 3m) | |
|---------|---|----------|
| ANT | CH01 2412MHz | |
| 1 | Horizontal | Vertical |
| Peak | | |
| Average | | |

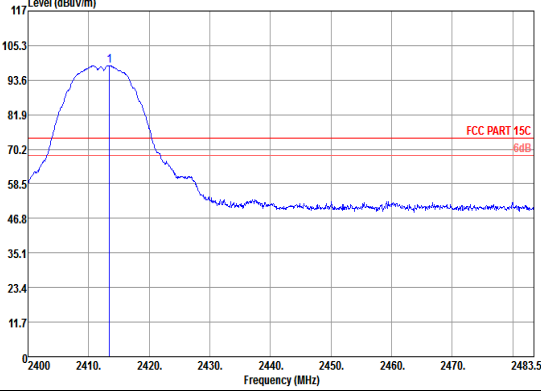
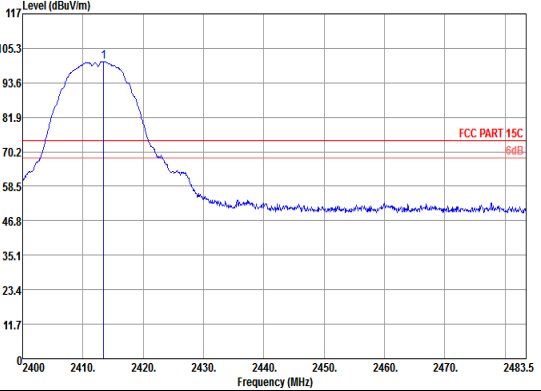
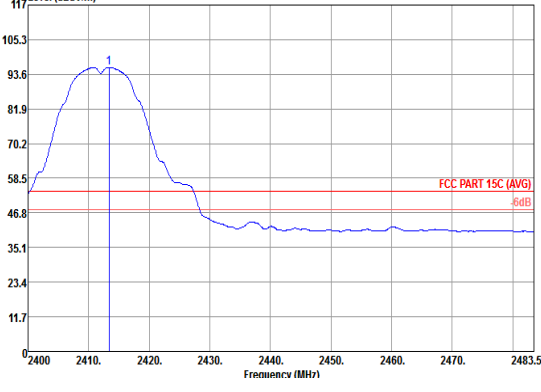
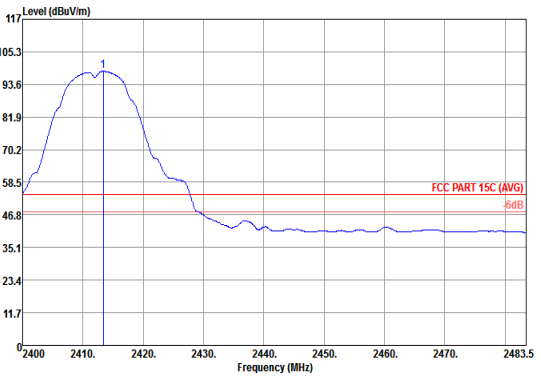

| WIFI | 2.4GHz 2400~2483.5MHz WIFI 802.11b (Fundamental Emission @ 3m) | |
|---------|--|---|
| ANT | CH01 2412MHz | |
| 1 | Horizontal | Vertical |
| Peak |  |  |
| Average |  |  |

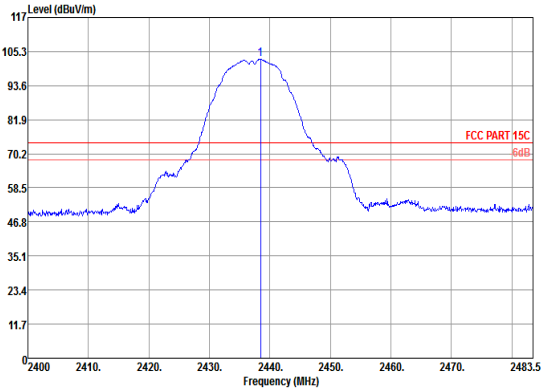
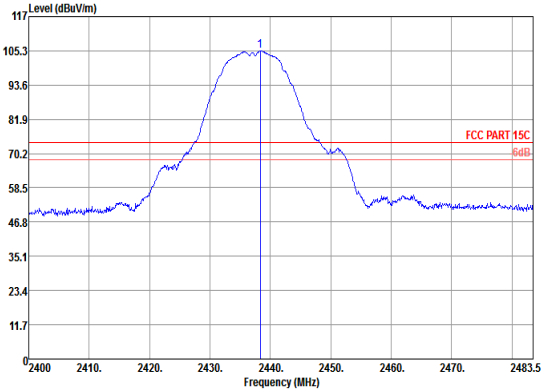
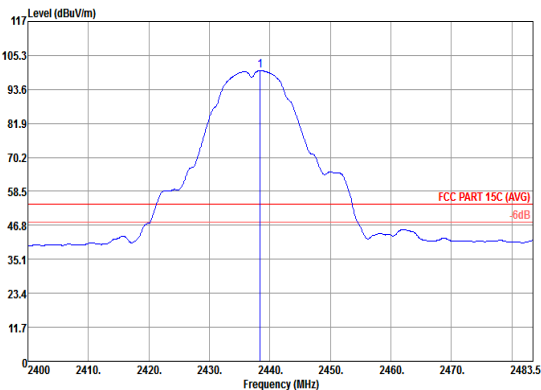
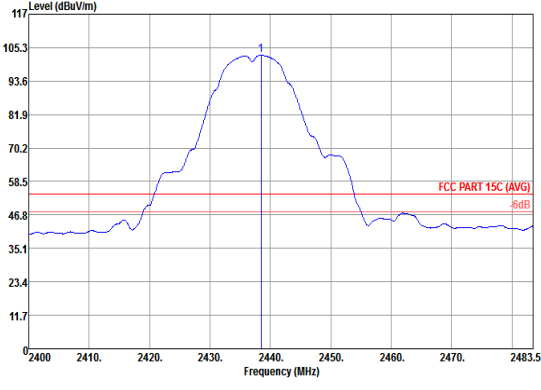

| WIFI | 2.4GHz 2400~2483.5MHz WIFI 802.11b (Fundamental Emission @ 3m) | |
|---------|--|---|
| ANT | CH06 2437MHz | |
| 1 | Horizontal | Vertical |
| Peak |  |  |
| Average |  |  |

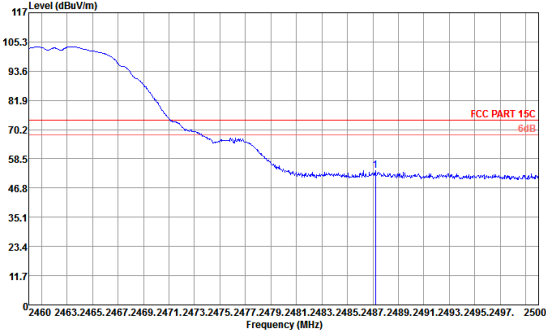
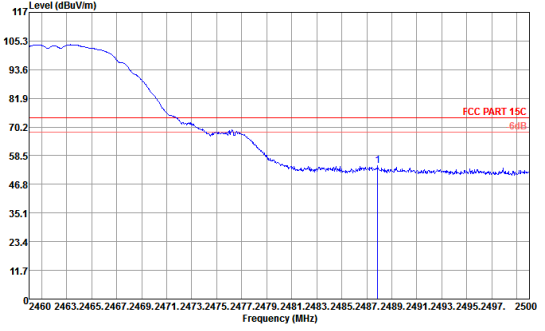
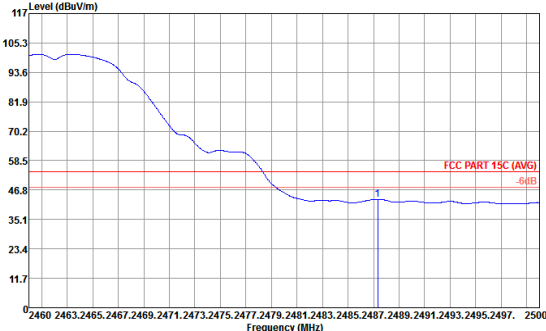
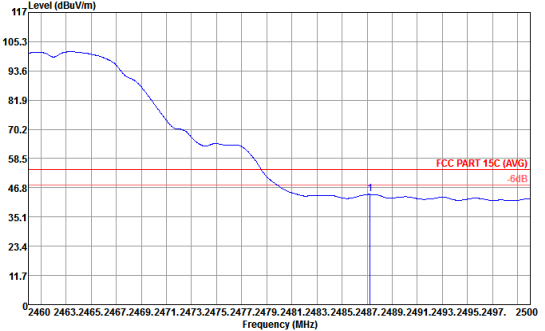

| WIFI | 2.4GHz 2400~2483.5MHz WIFI 802.11b (Band Edge @ 3m) | |
|---------|--|---|
| ANT | CH11 2462MHz | |
| 1 | Horizontal | Vertical |
| Peak |  |  |
| Average |  |  |

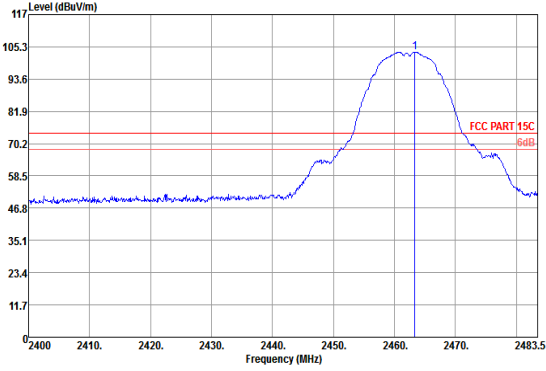
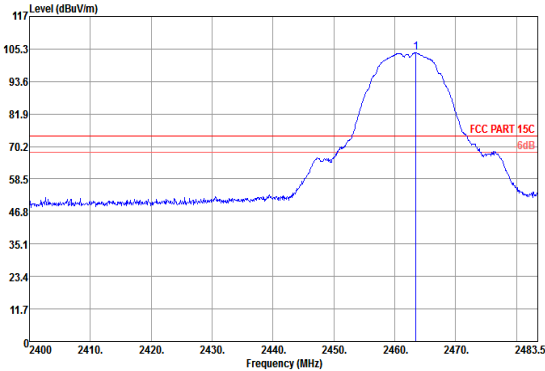
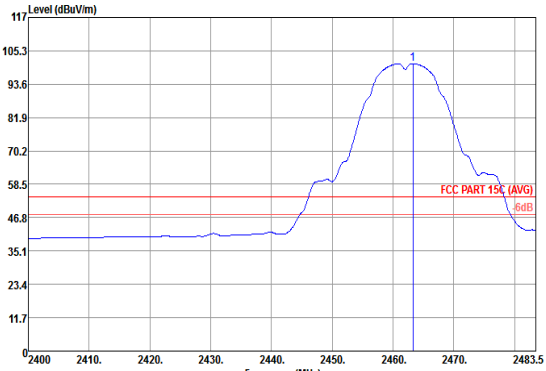
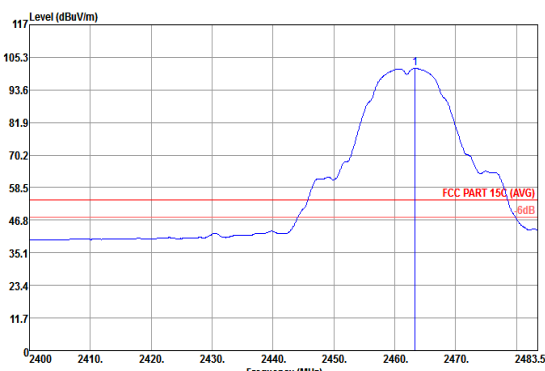

| WIFI | 2.4GHz 2400~2483.5MHz WIFI 802.11b (Fundamental Emission @ 3m) | |
|---------|--|---|
| ANT | CH11 2462MHz | |
| 1 | Horizontal | Vertical |
| Peak |  |  |
| Average |  |  |

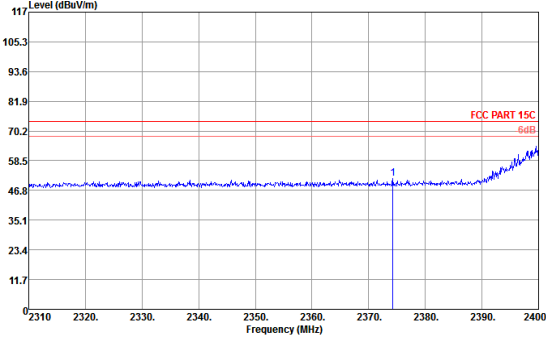
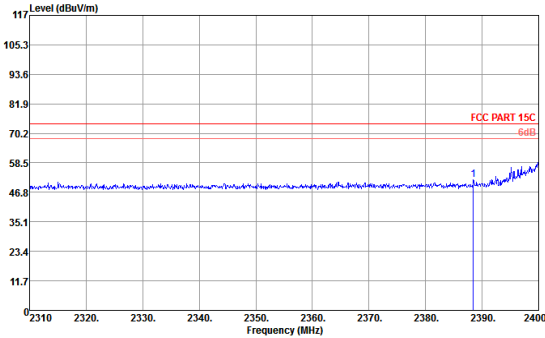
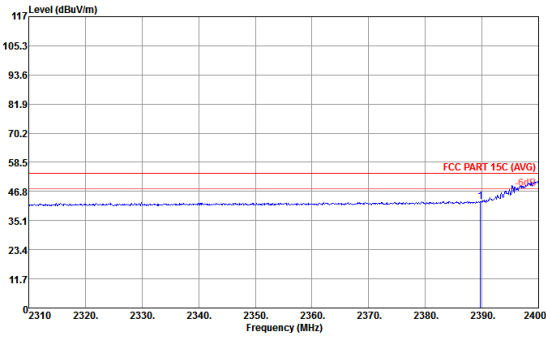
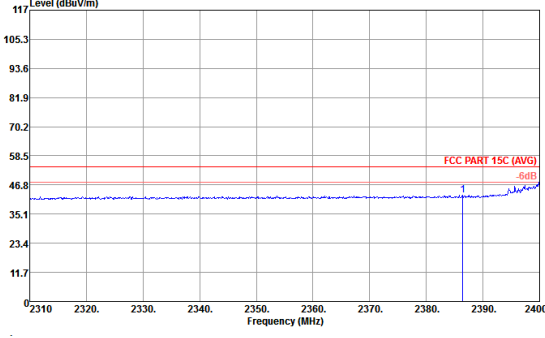

| WIFI | 2.4GHz 2400~2483.5MHz WIFI 802.11g (Band Edge @ 3m) | |
|---------|--|---|
| ANT | CH01 2412MHz | |
| 1 | Horizontal | Vertical |
| Peak |  |  |
| Average |  |  |

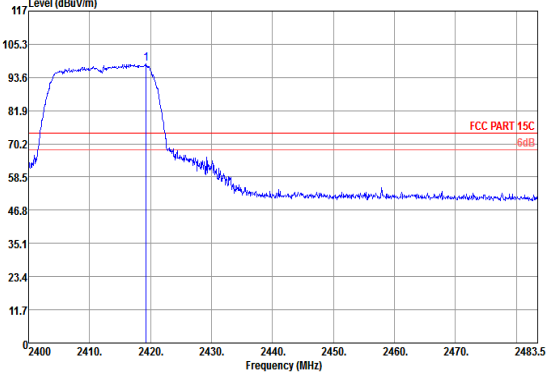
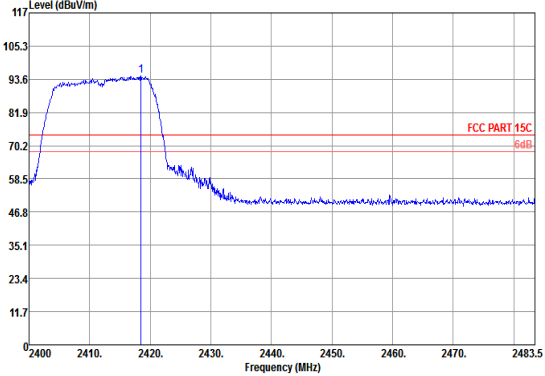
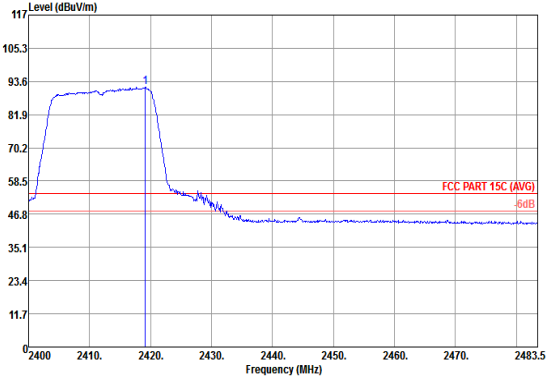
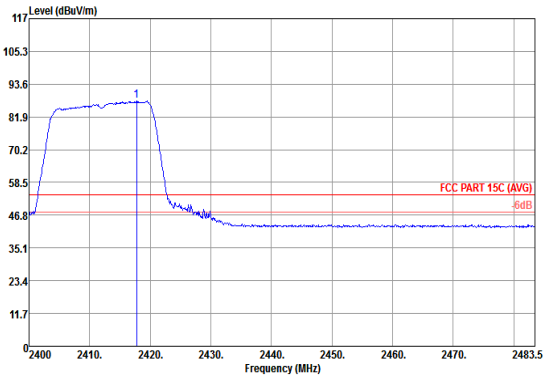

| WIFI | 2.4GHz 2400~2483.5MHz WIFI 802.11g (Fundamental Emission @ 3m) | |
|---------|--|---|
| ANT | CH01 2412MHz | |
| 1 | Horizontal | Vertical |
| Peak |  |  |
| Average |  |  |

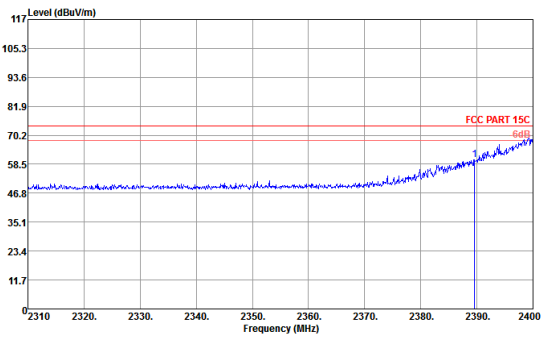
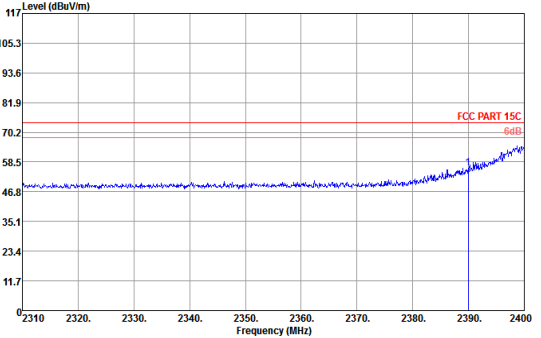
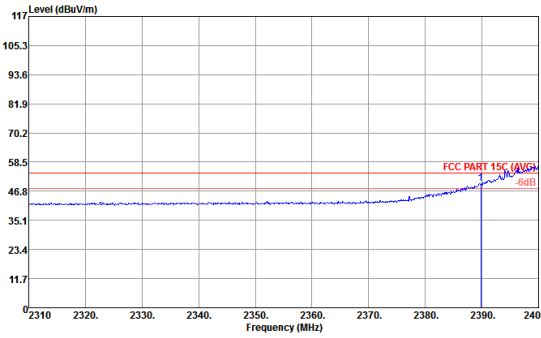
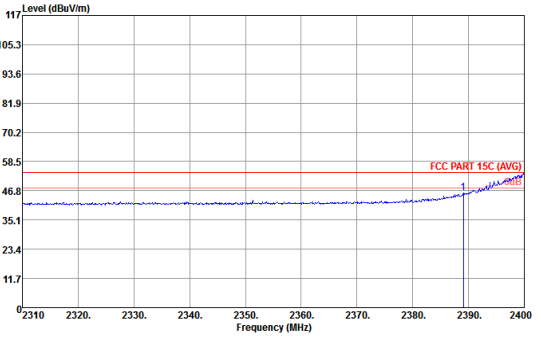

| WIFI | 2.4GHz 2400~2483.5MHz WIFI 802.11g (Band Edge @ 3m) | |
|---------|--|---|
| ANT | CH02 2417MHz | |
| 1 | Horizontal | Vertical |
| Peak |  |  |
| Average |  |  |

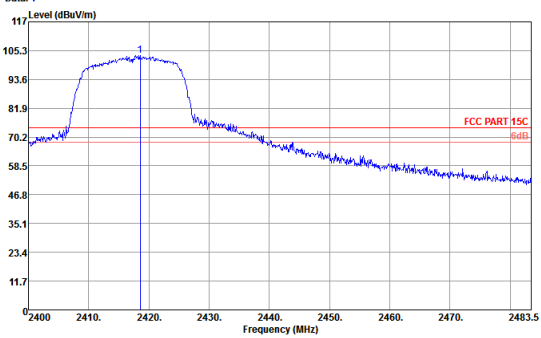
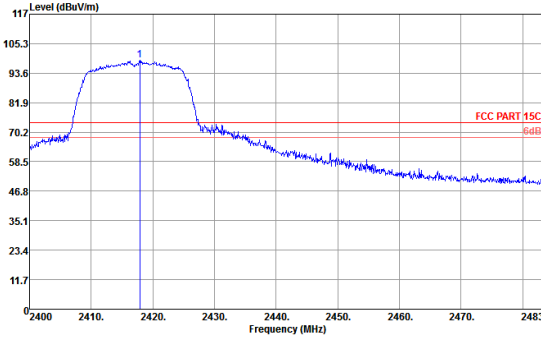
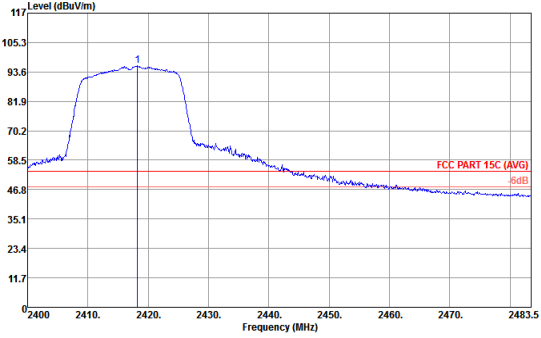
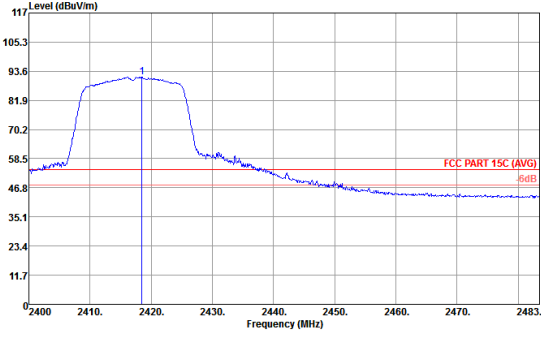

| WIFI | 2.4GHz 2400~2483.5MHz WIFI 802.11g (Fundamental Emission @ 3m) | |
|---------|--|---|
| ANT | CH02 2417MHz | |
| 1 | Horizontal | Vertical |
| Peak |  |  |
| Average |  |  |

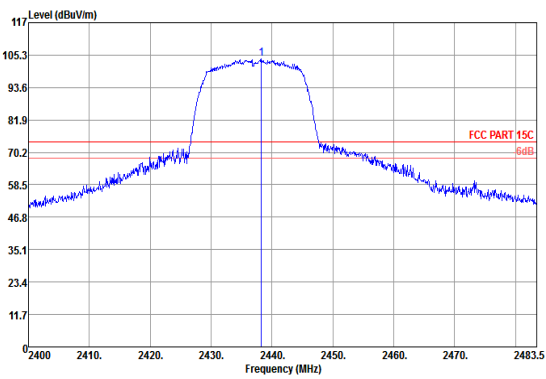
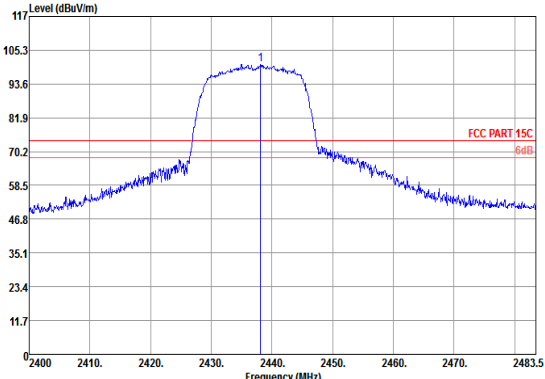
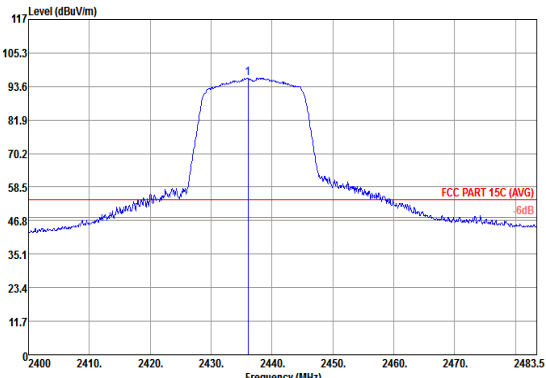
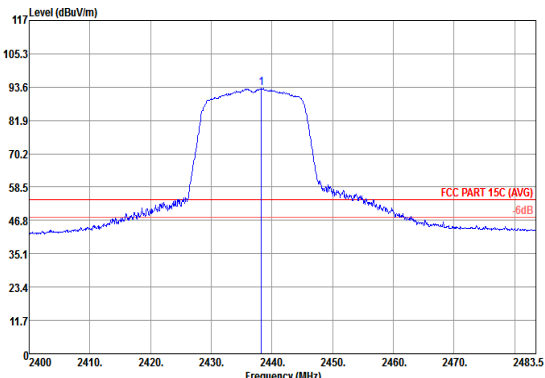

| WIFI | 2.4GHz 2400~2483.5MHz WIFI 802.11g (Fundamental Emission @ 3m) | |
|---------|--|---|
| ANT | CH06 2437MHz | |
| 1 | Horizontal | Vertical |
| Peak |  |  |
| Average |  |  |

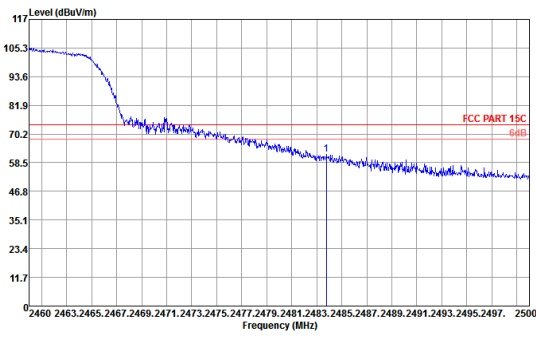
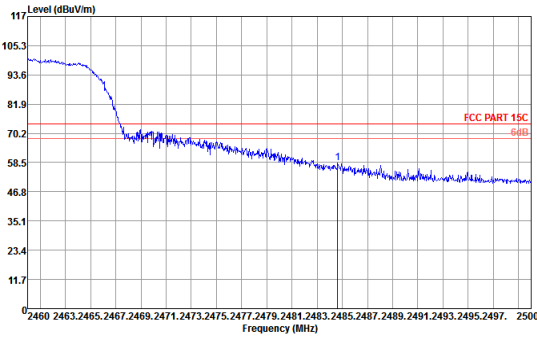
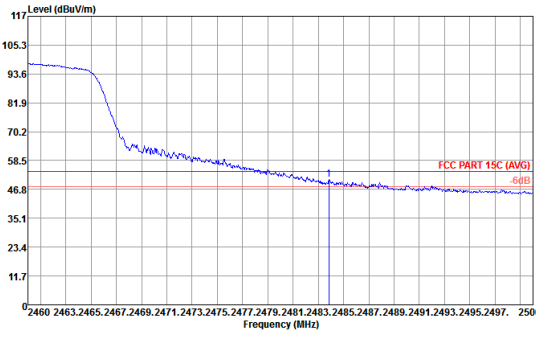
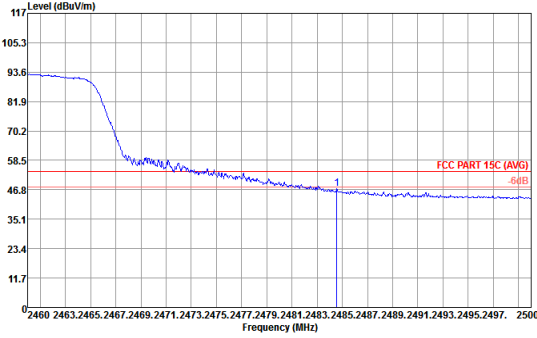

| WIFI | 2.4GHz 2400~2483.5MHz WIFI 802.11g (Band Edge @ 3m) | |
|---------|--|---|
| ANT | CH10 2457MHz | |
| 1 | Horizontal | Vertical |
| Peak |  <p>Level (dBuV/m) vs Frequency (MHz) plot for Peak Horizontal. The y-axis ranges from 11.7 to 117 dBuV/m. The x-axis ranges from 2460 to 2500 MHz. A blue line shows the signal level, which starts at approximately 105.3 dBuV/m at 2460 MHz and drops to about 70.2 dBuV/m by 2470 MHz, then continues to decrease with noise. A red horizontal line is labeled 'FCC PART 15C -6dB'. A vertical blue line is at 2457 MHz.</p> |  <p>Level (dBuV/m) vs Frequency (MHz) plot for Peak Vertical. The y-axis ranges from 11.7 to 117 dBuV/m. The x-axis ranges from 2460 to 2500 MHz. A blue line shows the signal level, which starts at approximately 105.3 dBuV/m at 2460 MHz and drops to about 70.2 dBuV/m by 2470 MHz, then continues to decrease with noise. A red horizontal line is labeled 'FCC PART 15C -6dB'. A vertical blue line is at 2457 MHz.</p> |
| Average |  <p>Level (dBuV/m) vs Frequency (MHz) plot for Average Horizontal. The y-axis ranges from 11.7 to 117 dBuV/m. The x-axis ranges from 2460 to 2500 MHz. A blue line shows the average signal level, which starts at approximately 93.6 dBuV/m at 2460 MHz and drops to about 58.5 dBuV/m by 2470 MHz, then continues to decrease with noise. A red horizontal line is labeled 'FCC PART 15C (AVG) -6dB'. A vertical blue line is at 2457 MHz.</p> |  <p>Level (dBuV/m) vs Frequency (MHz) plot for Average Vertical. The y-axis ranges from 11.7 to 117 dBuV/m. The x-axis ranges from 2460 to 2500 MHz. A blue line shows the average signal level, which starts at approximately 93.6 dBuV/m at 2460 MHz and drops to about 58.5 dBuV/m by 2470 MHz, then continues to decrease with noise. A red horizontal line is labeled 'FCC PART 15C (AVG) -6dB'. A vertical blue line is at 2457 MHz.</p> |

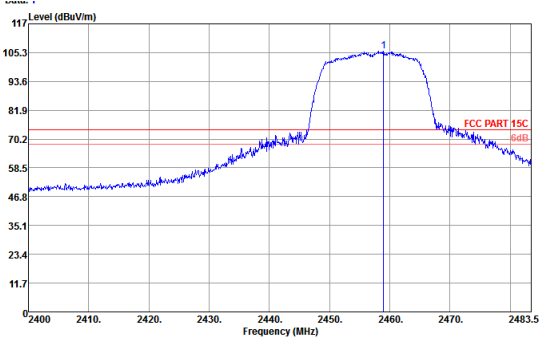
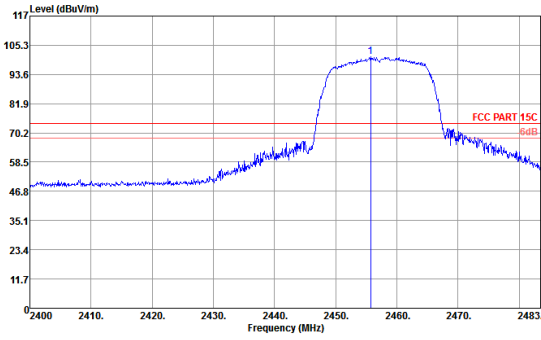
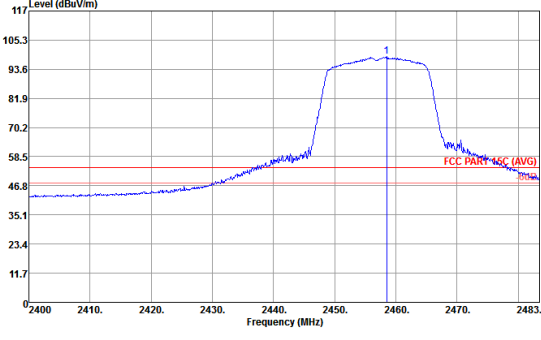
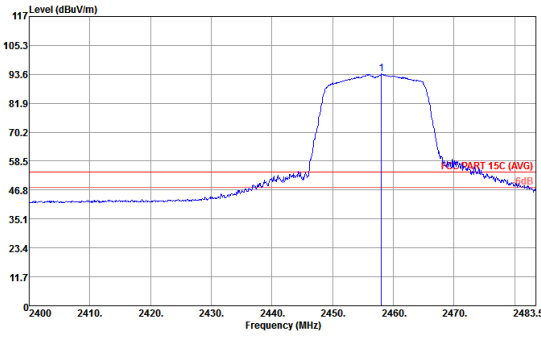

| WIFI | 2.4GHz 2400~2483.5MHz WIFI 802.11g (Fundamental Emission @ 3m) | |
|---------|--|---|
| ANT | CH10 2457MHz | |
| 1 | Horizontal | Vertical |
| Peak |  |  |
| Average |  |  |

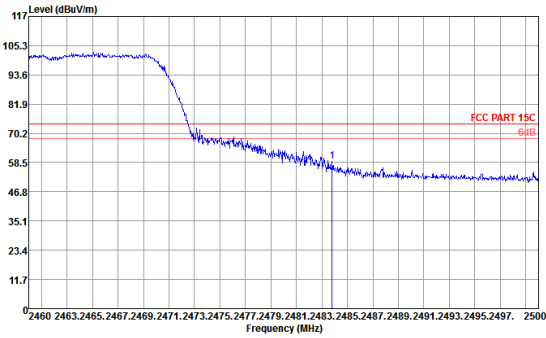
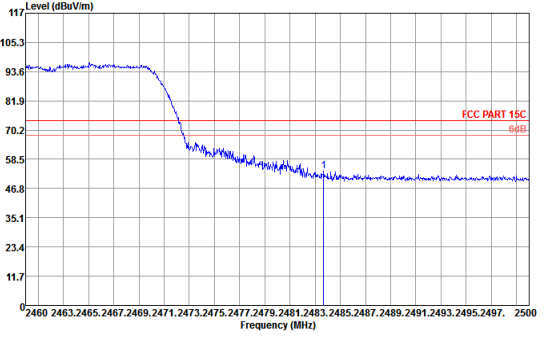
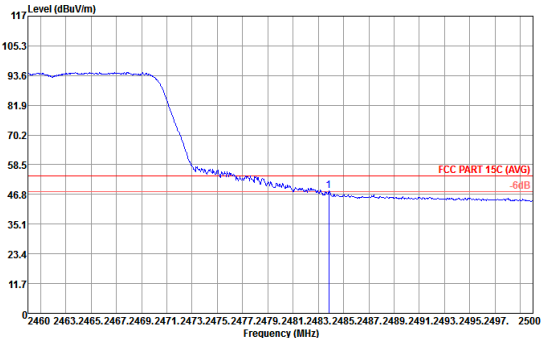
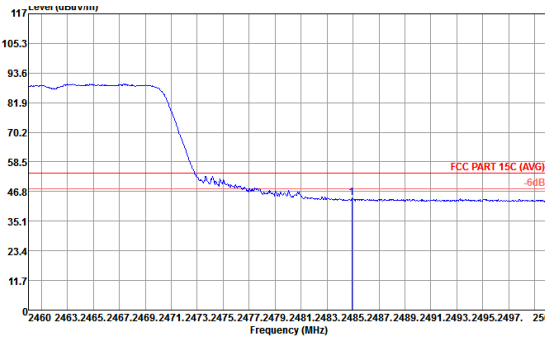

| WIFI | 2.4GHz 2400~2483.5MHz WIFI 802.11g (Band Edge @ 3m) | |
|---------|--|---|
| ANT | CH11 2462MHz | |
| 1 | Horizontal | Vertical |
| Peak |  <p>Level (dBuV/m) vs Frequency (MHz) for Horizontal orientation. The plot shows a signal level starting at approximately 105.3 dBuV/m at 2460 MHz, dropping to about 70.2 dBuV/m by 2470 MHz, and then fluctuating between 58.5 and 60 dBuV/m up to 2500 MHz. A red horizontal line at 70.2 dBuV/m is labeled 'FCC PART 15C -6dB'. A vertical blue line is at 2462 MHz.</p> |  <p>Level (dBuV/m) vs Frequency (MHz) for Vertical orientation. The plot shows a signal level starting at approximately 105.3 dBuV/m at 2460 MHz, dropping to about 70.2 dBuV/m by 2470 MHz, and then fluctuating between 58.5 and 60 dBuV/m up to 2500 MHz. A red horizontal line at 70.2 dBuV/m is labeled 'FCC PART 15C -6dB'. A vertical blue line is at 2462 MHz.</p> |
| Average |  <p>Level (dBuV/m) vs Frequency (MHz) for Horizontal orientation (Average). The plot shows a smoothed signal level starting at approximately 93.6 dBuV/m at 2460 MHz, dropping to about 58.5 dBuV/m by 2470 MHz, and then fluctuating between 46.8 and 50 dBuV/m up to 2500 MHz. A red horizontal line at 58.5 dBuV/m is labeled 'FCC PART 15C (AVG) -6dB'. A vertical blue line is at 2462 MHz.</p> |  <p>Level (dBuV/m) vs Frequency (MHz) for Vertical orientation (Average). The plot shows a smoothed signal level starting at approximately 93.6 dBuV/m at 2460 MHz, dropping to about 58.5 dBuV/m by 2470 MHz, and then fluctuating between 46.8 and 50 dBuV/m up to 2500 MHz. A red horizontal line at 58.5 dBuV/m is labeled 'FCC PART 15C (AVG) -6dB'. A vertical blue line is at 2462 MHz.</p> |

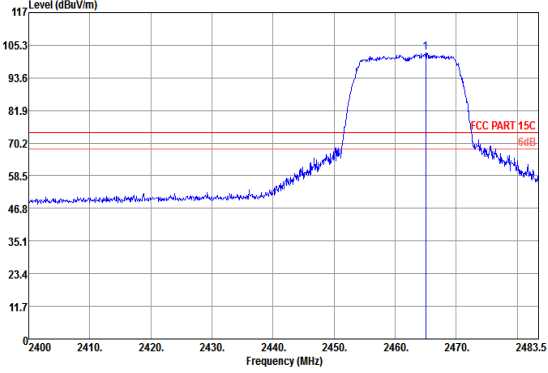
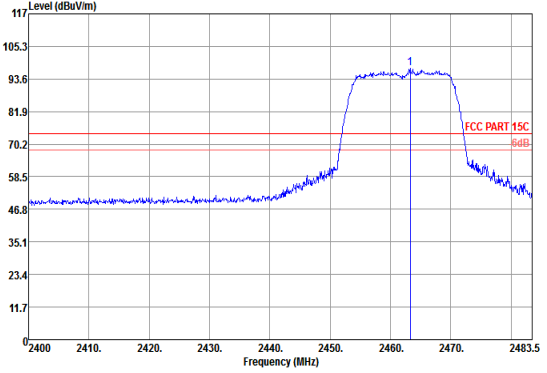
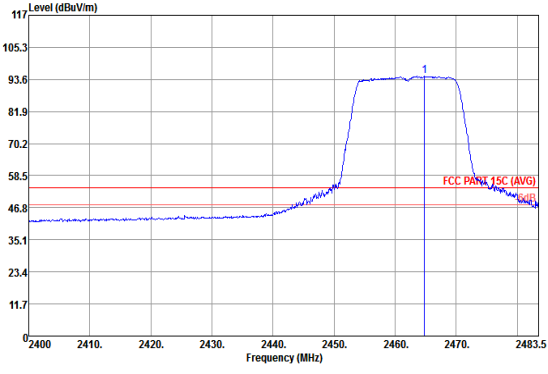
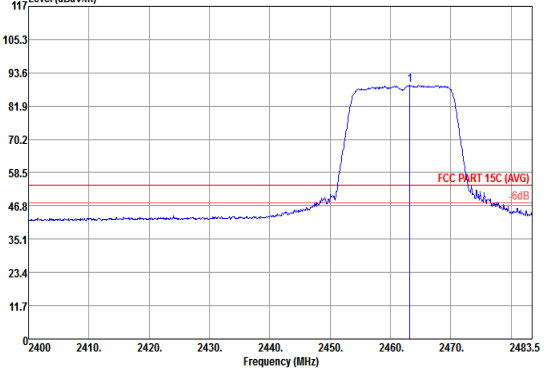

| WIFI | 2.4GHz 2400~2483.5MHz WIFI 802.11g (Fundamental Emission @ 3m) | |
|---------|--|---|
| ANT | CH11 2462MHz | |
| 1 | Horizontal | Vertical |
| Peak |  |  |
| Average |  |  |

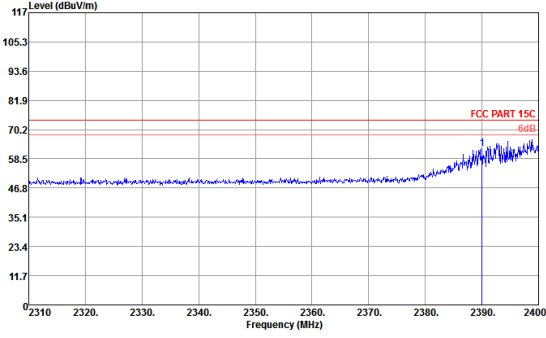
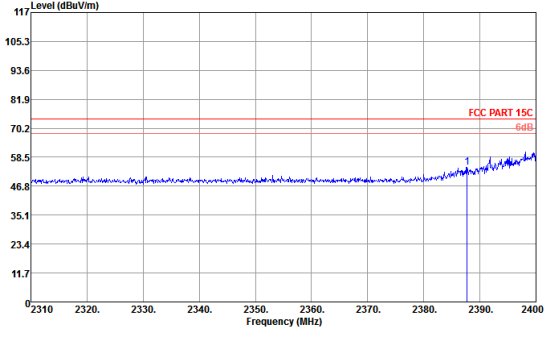
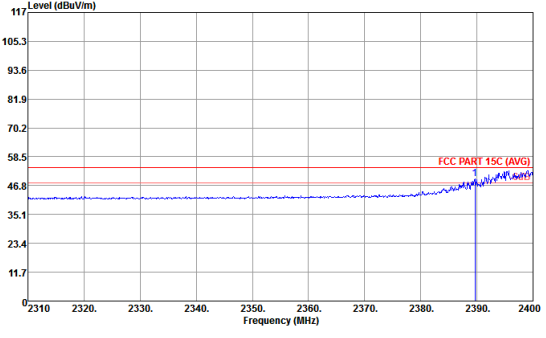
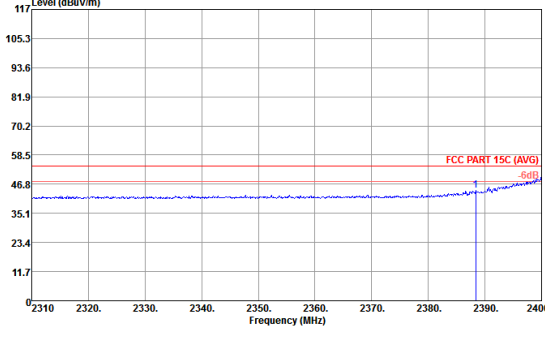

| WIFI | 2.4GHz 2400~2483.5MHz WIFI 802.11n HT20 (Band Edge @ 3m) | |
|---------|--|---|
| ANT | CH01 2412MHz | |
| 1 | Horizontal | Vertical |
| Peak |  |  |
| Average |  |  |

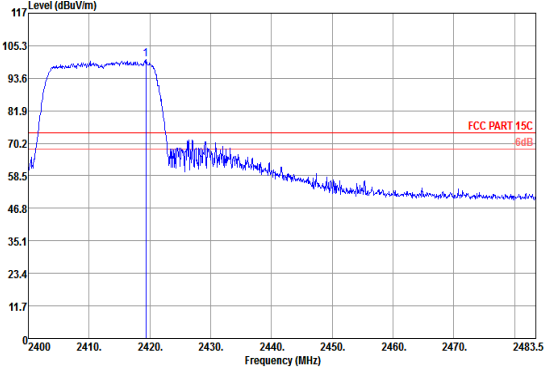
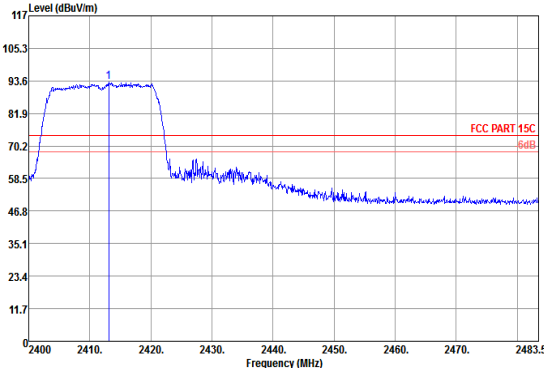
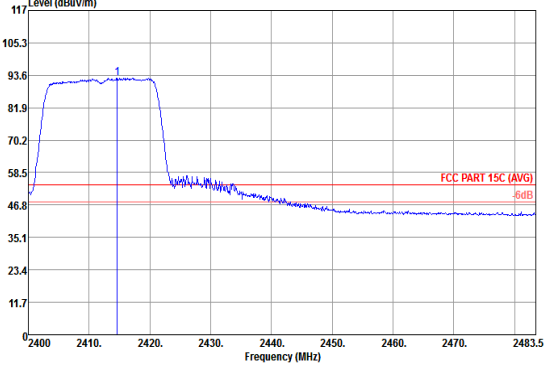
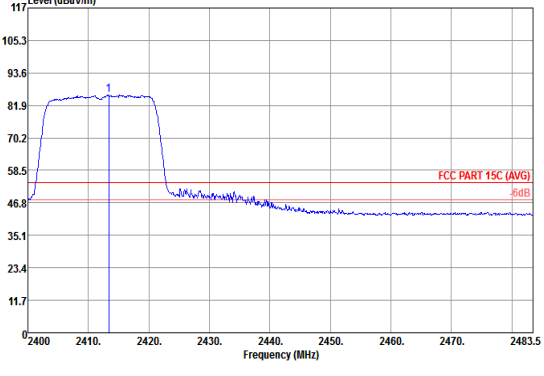

| WIFI | 2.4GHz 2400~2483.5MHz WIFI 802.11n HT20 (Fundamental Emission @ 3m) | |
|---------|--|---|
| ANT | CH01 2412MHz | |
| 1 | Horizontal | Vertical |
| Peak |  |  |
| Average |  |  |



| WIFI | 2.4GHz 2400~2483.5MHz WIFI 802.11n HT20 (Fundamental Emission @ 3m) | |
|---------|---|----------|
| ANT | CH06 2437MHz | |
| 1 | Horizontal | Vertical |
| Peak | | |
| Average | | |

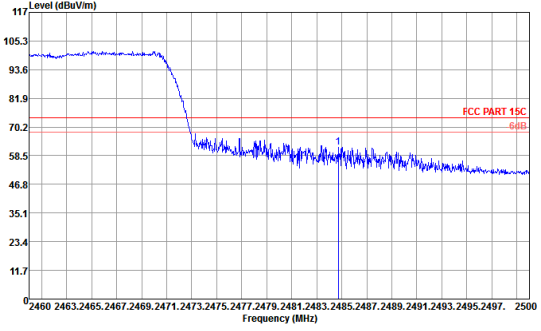
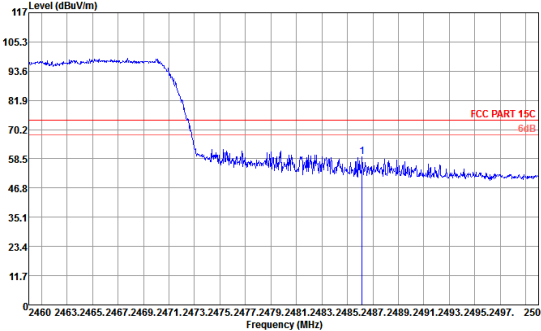
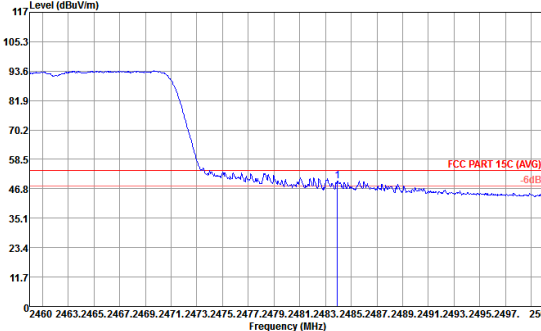
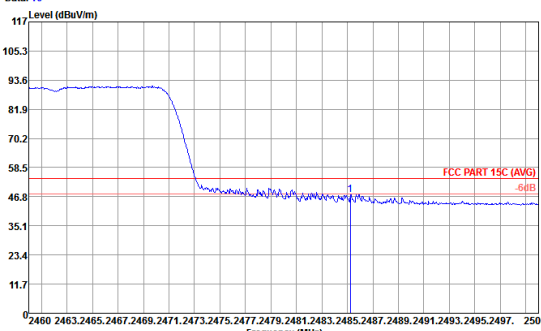

| WIFI | 2.4GHz 2400~2483.5MHz WIFI 802.11n HT20 (Band Edge @ 3m) | |
|---------|--|---|
| ANT | CH11 2462MHz | |
| 1 | Horizontal | Vertical |
| Peak |  |  |
| Average |  |  |

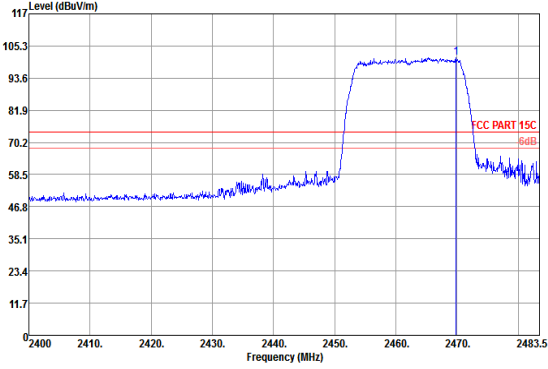
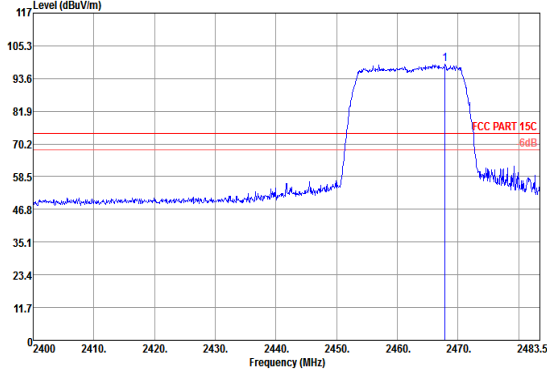
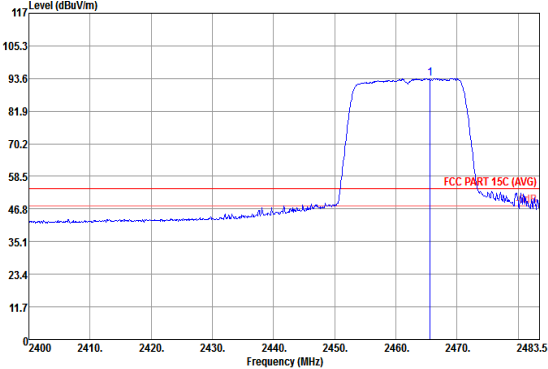
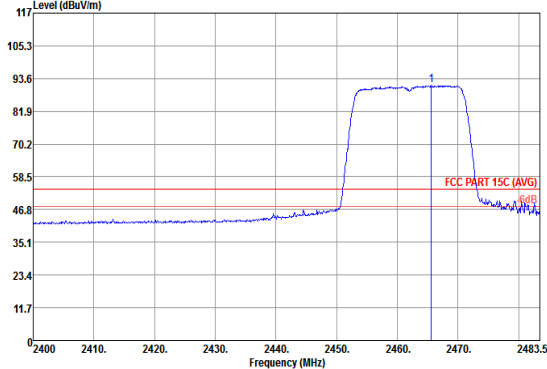

| WIFI | 2.4GHz 2400~2483.5MHz WIFI 802.11n HT20 (Fundamental Emission @ 3m) | |
|---------|--|---|
| ANT | CH11 2462MHz | |
| 1 | Horizontal | Vertical |
| Peak |  |  |
| Average |  |  |



| WIFI | 2.4GHz 2400~2483.5MHz WIFI 802.11n HT40 (Band Edge @ 3m) | |
|---------|--|------------|
| ANT | CH03 2422MHz | |
| 1 | Horizontal | Horizontal |
| Peak | | |
| Average | | |
| 1 | Vertical | Vertical |
| Peak | | |

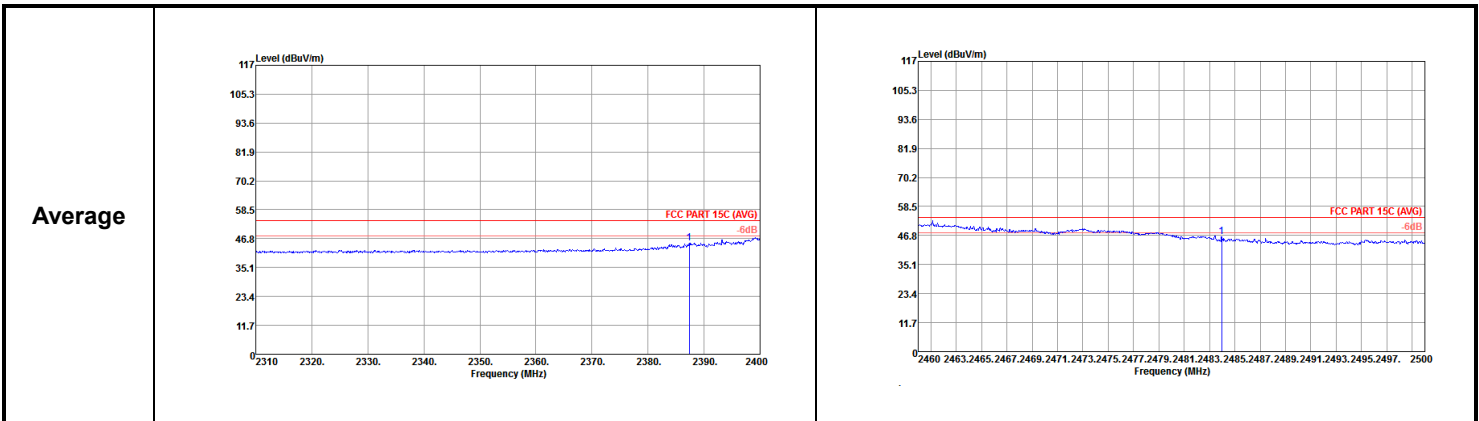

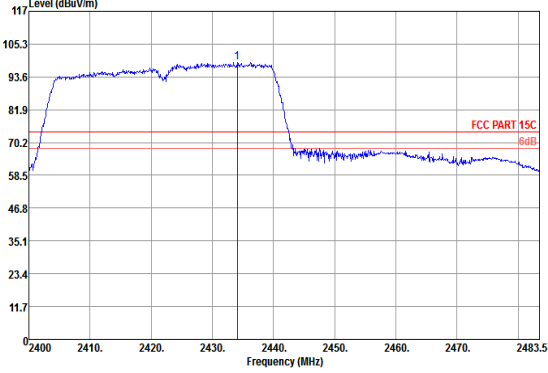
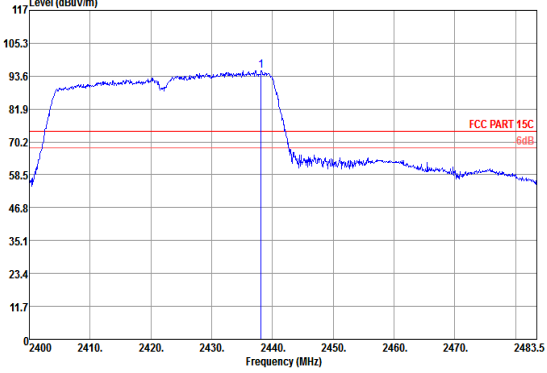
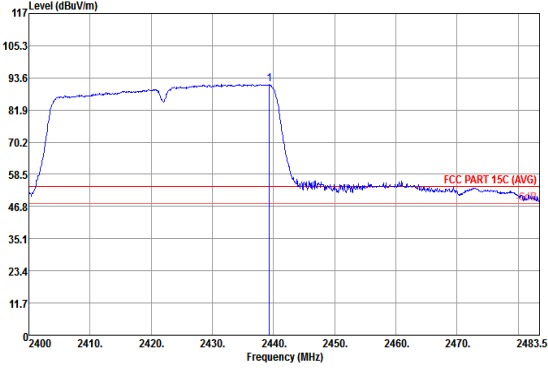
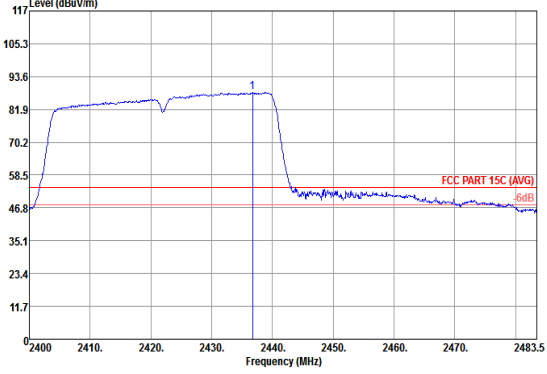

| WIFI | 2.4GHz 2400~2483.5MHz WIFI 802.11n HT40 (Fundamental Emission @ 3m) | |
|---------|--|---|
| ANT | CH03 2422MHz | |
| 1 | Horizontal | Vertical |
| Peak |  |  |
| Average |  |  |



| | | |
|---------|---|------------|
| WIFI | 2.4GHz 2400~2483.5MHz WIFI 802.11 n HT40 (Band Edge @ 3m) | |
| ANT | CH06 2437MHz | |
| 1 | Horizontal | Horizontal |
| Peak | | |
| Average | | |
| 1 | Vertical | Vertical |
| Peak | | |

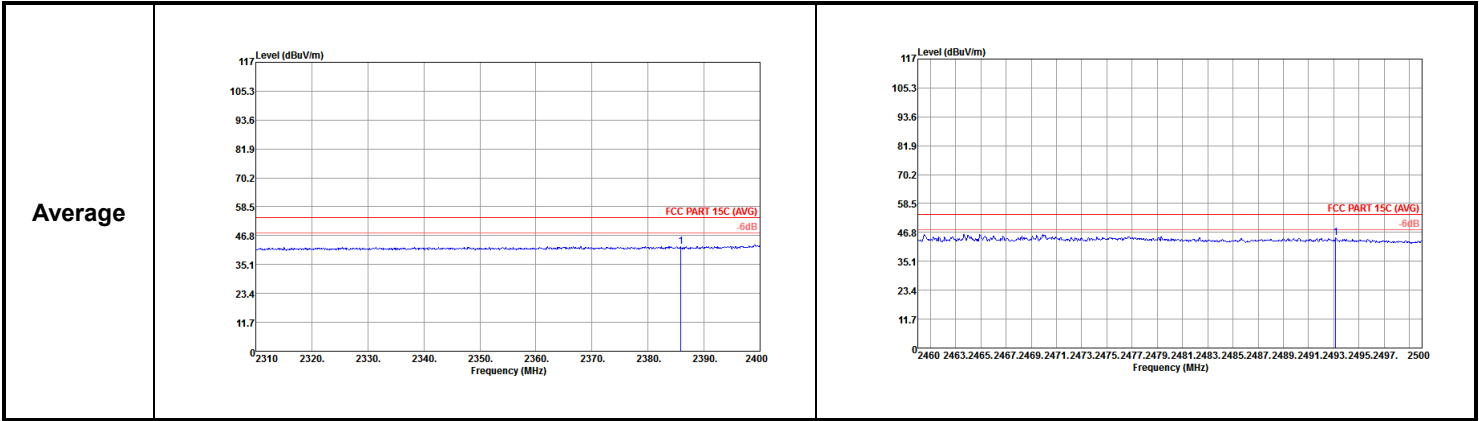

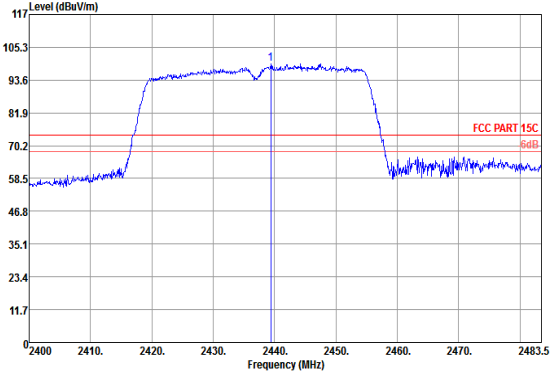
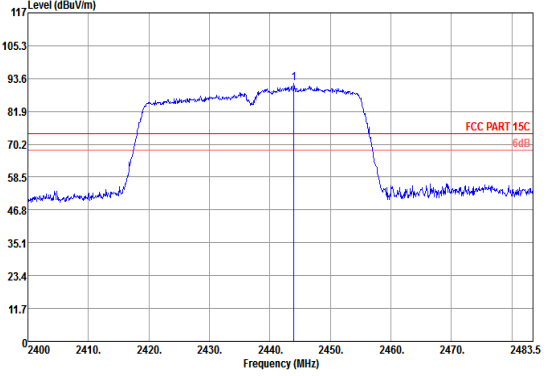
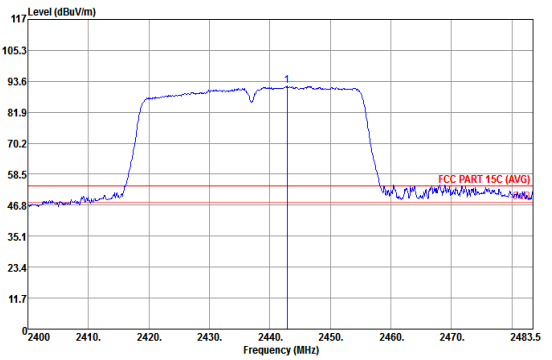
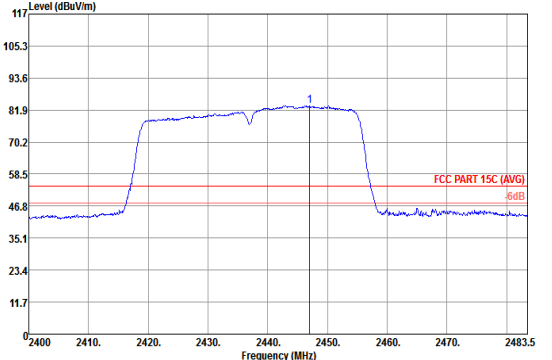

| WIFI | 2.4GHz 2400~2483.5MHz WIFI 802.11n HT40 (Fundamental Emission @ 3m) | |
|---------|--|---|
| ANT | CH06 2437MHz | |
| 1 | Horizontal | Vertical |
| Peak |  |  |
| Average |  |  |



| WIFI | 2.4GHz 2400~2483.5MHz WIFI 802.11 n HT40 (Band Edge @ 3m) | |
|---------|---|------------|
| ANT | CH09 2452MHz | |
| 1 | Horizontal | Horizontal |
| Peak | | |
| Average | | |
| 1 | Vertical | Vertical |
| Peak | | |

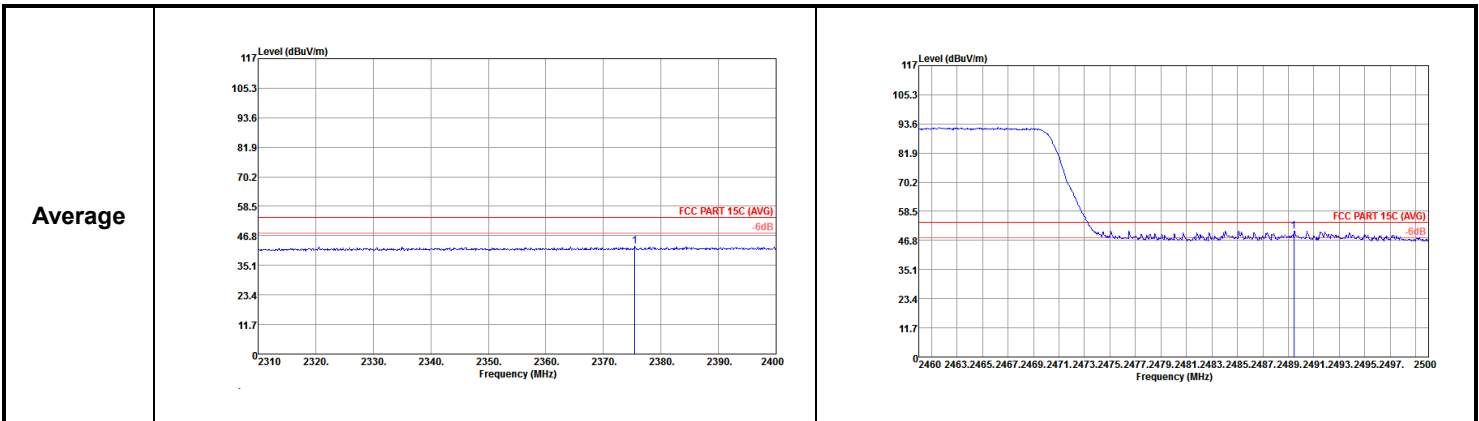

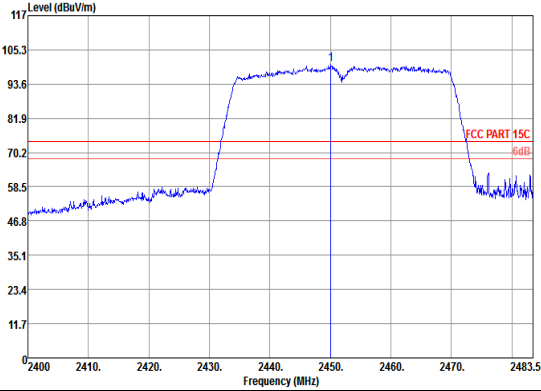
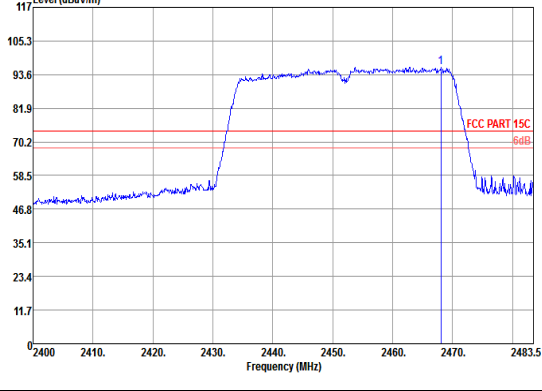
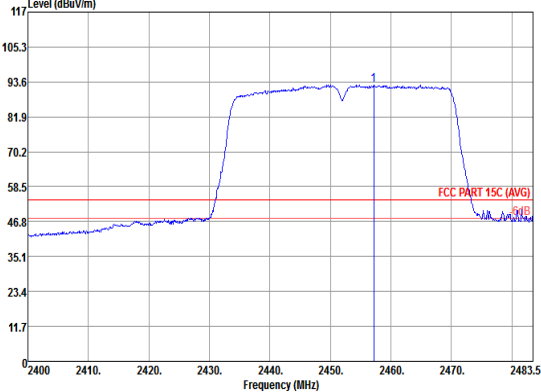
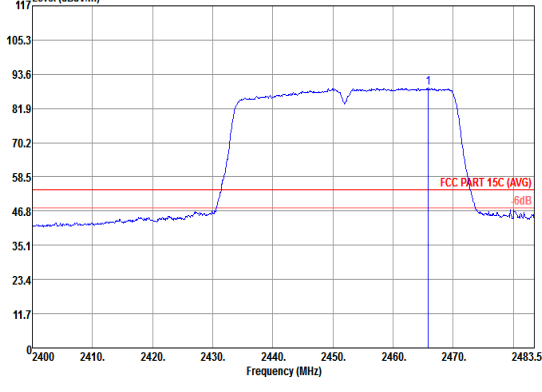

| WIFI | 2.4GHz 2400~2483.5MHz WIFI 802.11 n HT40 (Fundamental Emission @ 3m) | |
|---------|--|---|
| ANT | CH09 2452MHz | |
| 1 | Horizontal | Vertical |
| Peak |  |  |
| Average |  |  |



| | | |
|------|--|----------|
| WIFI | 2.4GHz 2400~2483.5MHz WIFI 802.11b (Harmonic @ 3m) | |
| ANT | CH01 2412MHz | |
| 1 | Horizontal | Vertical |
| Peak | | |
| WIFI | 2.4GHz 2400~2483.5MHz WIFI 802.11b (Harmonic @ 3m) | |
| ANT | CH06 2437MHz | |
| 1 | Horizontal | Vertical |
| Peak | | |
| WIFI | 2.4GHz 2400~2483.5MHz WIFI 802.11b (Harmonic @ 3m) | |
| ANT | CH11 2462MHz | |
| 1 | Horizontal | Vertical |
| Peak | | |



| | | |
|------|--|----------|
| WIFI | 2.4GHz 2400~2483.5MHz WIFI 802.11g (Harmonic @ 3m) | |
| ANT | CH01 2412MHz | |
| 1 | Horizontal | Vertical |
| Peak | | |
| WIFI | 2.4GHz 2400~2483.5MHz WIFI 802.11g (Harmonic @ 3m) | |
| ANT | CH02 2417MHz | |
| 1 | Horizontal | Vertical |
| Peak | | |
| WIFI | 2.4GHz 2400~2483.5MHz WIFI 802.11g (Harmonic @ 3m) | |
| ANT | CH06 2437MHz | |
| 1 | Horizontal | Vertical |
| Peak | | |



| | | |
|------|--|----------|
| WIFI | 2.4GHz 2400~2483.5MHz WIFI 802.11g (Harmonic @ 3m) | |
| ANT | CH10 2457MHz | |
| 1 | Horizontal | Vertical |
| Peak | | |
| WIFI | 2.4GHz 2400~2483.5MHz WIFI 802.11g (Harmonic @ 3m) | |
| ANT | CH11 2462MHz | |
| 1 | Horizontal | Vertical |
| Peak | | |



| | | |
|------|---|----------|
| WIFI | 2.4GHz 2400~2483.5MHz WIFI 802.11n HT20 (Harmonic @ 3m) | |
| ANT | CH01 2412MHz | |
| 1 | Horizontal | Vertical |
| Peak | | |
| WIFI | 2.4GHz 2400~2483.5MHz WIFI 802.11n HT20 (Harmonic @ 3m) | |
| ANT | CH06 2437MHz | |
| 1 | Horizontal | Vertical |
| Peak | | |
| WIFI | 2.4GHz 2400~2483.5MHz WIFI 802.11n HT20 (Harmonic @ 3m) | |
| ANT | CH11 2462MHz | |
| 1 | Horizontal | Vertical |
| Peak | | |



| | | |
|------|---|----------|
| WIFI | 2.4GHz 2400~2483.5MHz WIFI 802.11n HT40 (Harmonic @ 3m) | |
| ANT | CH03 2422MHz | |
| 1 | Horizontal | Vertical |
| Peak | | |
| WIFI | 2.4GHz 2400~2483.5MHz WIFI 802.11n HT40 (Harmonic @ 3m) | |
| ANT | CH06 2437MHz | |
| 1 | Horizontal | Vertical |
| Peak | | |
| WIFI | 2.4GHz 2400~2483.5MHz WIFI 802.11n HT40 (Harmonic @ 3m) | |
| ANT | CH09 2452MHz | |
| 1 | Horizontal | Vertical |
| Peak | | |

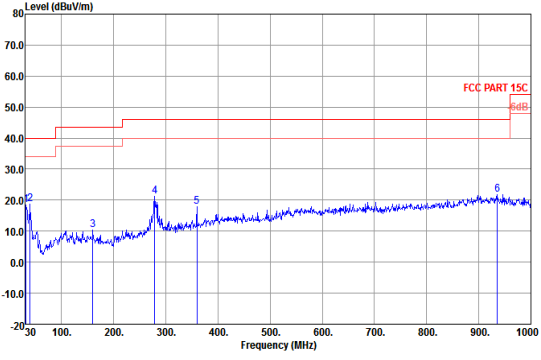
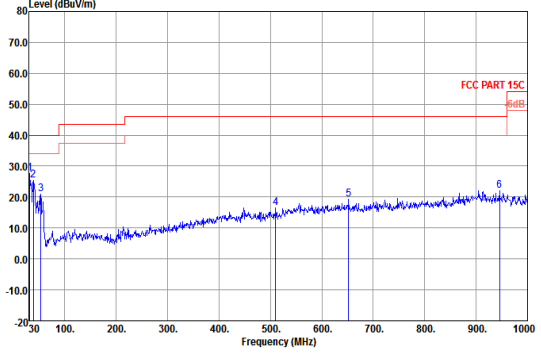

| WIFI | Emission below 1GHz | |
|------|---|--|
| ANT | 2.4GHz WIFI 802.11n HT40 (LF) | |
| 1 | Horizontal | Vertical |
| Peak |  |  |



2.4GHz 2400~2483.5MHz

WIFI 802.11b (Band Edge @ 3m)

| WIFI | Note | Frequency | Level | Over | Limit | Read | Antenna | Cable | Preamp | Ant | Table | Peak | Pol. |
|-----------------------------|---|-----------|------------|--------|------------|----------|----------|--------|--------|--------|---------|-------|-------|
| Ant. | | | | Limit | Line | Level | Factor | Loss | Factor | Pos | Pos | Avg. | |
| 1 | | (MHz) | (dBμV/m) | (dB) | (dBμV/m) | (dBμV) | (dB/m) | (dB) | (dB) | (cm) | (deg) | (P/A) | (H/V) |
| 802.11b CH 01 2412MHz | | 2339.25 | 51.38 | -22.62 | 74 | 56.01 | 26.86 | 5.52 | 37.01 | 300 | 24 | P | H |
| | | 2389.47 | 40.83 | -13.17 | 54 | 45.26 | 27 | 5.59 | 37.02 | 300 | 24 | A | H |
| | * | 2413.444 | 98.44 | - | - | 102.7 | 27.13 | 5.61 | 37 | 300 | 24 | P | H |
| | * | 2413.36 | 95.95 | - | - | 100.21 | 27.13 | 5.61 | 37 | 300 | 24 | A | H |
| | | 2389.02 | 52.04 | -21.96 | 74 | 56.47 | 27 | 5.59 | 37.02 | 171 | 128 | P | V |
| | | 2389.38 | 42 | -12 | 54 | 46.43 | 27 | 5.59 | 37.02 | 171 | 128 | A | V |
| | * | 2413.444 | 100.86 | - | - | 105.12 | 27.13 | 5.61 | 37 | 171 | 128 | P | V |
| | * | 2413.36 | 98.3 | - | - | 102.56 | 27.13 | 5.61 | 37 | 171 | 128 | A | V |
| 802.11b CH 06 2437MHz | * | 2438.493 | 102.6 | - | - | 106.53 | 27.39 | 5.65 | 36.97 | 296 | 38 | P | H |
| | * | 2438.41 | 100.05 | - | - | 103.98 | 27.39 | 5.65 | 36.97 | 296 | 38 | A | H |
| | * | 2438.326 | 105.19 | - | - | 109.12 | 27.39 | 5.65 | 36.97 | 100 | 185 | P | V |
| | * | 2438.493 | 102.62 | - | - | 106.55 | 27.39 | 5.65 | 36.97 | 100 | 185 | A | V |
| 802.11b CH 11 2462MHz | * | 2463.376 | 103.4 | - | - | 107.18 | 27.51 | 5.67 | 36.96 | 202 | 31 | P | H |
| | * | 2463.293 | 100.82 | - | - | 104.6 | 27.51 | 5.67 | 36.96 | 202 | 31 | A | H |
| | | 2487.2 | 53.87 | -20.13 | 74 | 57.48 | 27.64 | 5.69 | 36.94 | 202 | 31 | P | H |
| | | 2487.32 | 43.1 | -10.9 | 54 | 46.71 | 27.64 | 5.69 | 36.94 | 202 | 31 | A | H |
| | * | 2463.46 | 103.85 | - | - | 107.63 | 27.51 | 5.67 | 36.96 | 100 | 188 | P | V |
| | * | 2463.376 | 101.29 | - | - | 105.07 | 27.51 | 5.67 | 36.96 | 100 | 188 | A | V |
| | | 2487.88 | 54.43 | -19.57 | 74 | 57.88 | 27.77 | 5.71 | 36.93 | 100 | 188 | P | V |
| | | 2487.24 | 44.16 | -9.84 | 54 | 47.77 | 27.64 | 5.69 | 36.94 | 100 | 188 | A | V |
| Remark | <ol style="list-style-type: none"> No other spurious found. All results are PASS against Peak and Average limit line. | | | | | | | | | | | | |



2.4GHz 2400~2483.5MHz
WIFI 802.11b (Harmonic @ 3m)

Table with 14 columns: WIFI Ant. 1, Note, Frequency (MHz), Level (dBµV/m), Over Limit (dB), Limit Line (dBµV/m), Read Level (dBµV), Antenna Factor (dB/m), Cable Loss (dB), Preamp Factor (dB), Ant Pos (cm), Table Pos (deg), Peak Avg. (P/A), Pol. (H/V). Rows include data for CH 01 (2412MHz), CH 06 (2437MHz), and CH 11 (2462MHz).



2.4GHz 2400~2483.5MHz
WIFI 802.11g (Band Edge @ 3m)

Table with 14 columns: WIFI Ant. 1, Note, Frequency (MHz), Level (dBµV/m), Over Limit (dB), Limit Line (dBµV/m), Read Level (dBµV), Antenna Factor (dB/m), Cable Loss (dB), Preamp Factor (dB), Ant Pos (cm), Table Pos (deg), Peak Avg. (P/A), Pol. (H/V). Rows include data for 802.11g CH 01 (2412MHz) and CH 02 (2417MHz).



**2.4GHz 2400~2483.5MHz
WIFI 802.11g (Band Edge @ 3m)**

| WIFI Ant. 1 | Note | Frequency (MHz) | Level (dBμV/m) | Over Limit (dB) | Limit Line (dBμV/m) | Read Level (dBμV) | Antenna Factor (dB/m) | Cable Loss (dB) | Preamp Factor (dB) | Ant Pos (cm) | Table Pos (deg) | Peak Avg. (P/A) | Pol. (H/V) |
|-----------------------------|---|-------------------|------------------|-------------------|-----------------------|---------------------|-------------------------|-------------------|----------------------|----------------|-------------------|-------------------|--------------|
| 802.11g CH 06 2437MHz | * | 2438.243 | 103.89 | - | - | 107.82 | 27.39 | 5.65 | 36.97 | 165 | 235 | P | H |
| | * | 2436.072 | 96.51 | - | - | 100.61 | 27.26 | 5.63 | 36.99 | 165 | 235 | A | H |
| | * | 2438.159 | 100.51 | - | - | 104.44 | 27.39 | 5.65 | 36.97 | 364 | 97 | P | V |
| | * | 2438.243 | 93.14 | - | - | 97.07 | 27.39 | 5.65 | 36.97 | 364 | 97 | A | V |
| 802.11g CH 10 2457MHz | * | 2458.951 | 105.87 | - | - | 109.65 | 27.51 | 5.67 | 36.96 | 163 | 231 | P | H |
| | * | 2458.533 | 98.72 | - | - | 102.5 | 27.51 | 5.67 | 36.96 | 163 | 231 | A | H |
| | | 2483.76 | 61.8 | -12.2 | 74 | 65.41 | 27.64 | 5.69 | 36.94 | 163 | 231 | P | H |
| | ! | 2483.84 | 50.8 | -3.2 | 54 | 54.41 | 27.64 | 5.69 | 36.94 | 163 | 231 | A | H |
| | * | 2455.695 | 100.7 | - | - | 104.48 | 27.51 | 5.67 | 36.96 | 397 | 93 | P | V |
| | * | 2458.032 | 93.71 | - | - | 97.49 | 27.51 | 5.67 | 36.96 | 397 | 93 | A | V |
| | | 2484.64 | 58.32 | -15.68 | 74 | 61.93 | 27.64 | 5.69 | 36.94 | 397 | 93 | P | V |
| | | 2484.56 | 47.13 | -6.87 | 54 | 50.74 | 27.64 | 5.69 | 36.94 | 397 | 93 | A | V |
| 802.11g CH 11 2462MHz | * | 2465.046 | 102.62 | - | - | 106.4 | 27.51 | 5.67 | 36.96 | 107 | 31 | P | H |
| | * | 2464.796 | 94.73 | - | - | 98.51 | 27.51 | 5.67 | 36.96 | 107 | 31 | A | H |
| | | 2483.8 | 59.08 | -14.92 | 74 | 62.69 | 27.64 | 5.69 | 36.94 | 107 | 31 | P | H |
| | ! | 2483.84 | 48.35 | -5.65 | 54 | 51.96 | 27.64 | 5.69 | 36.94 | 107 | 31 | A | H |
| | * | 2463.293 | 97.49 | - | - | 101.27 | 27.51 | 5.67 | 36.96 | 100 | 28 | P | V |
| | * | 2463.209 | 89.19 | - | - | 92.97 | 27.51 | 5.67 | 36.96 | 100 | 28 | A | V |
| | | 2483.68 | 53.71 | -20.29 | 74 | 57.32 | 27.64 | 5.69 | 36.94 | 100 | 28 | P | V |
| | | 2484.92 | 44.21 | -9.79 | 54 | 47.82 | 27.64 | 5.69 | 36.94 | 100 | 28 | A | V |
| Remark | 1. No other spurious found. 2. All results are PASS against Peak and Average limit line. | | | | | | | | | | | | |



2.4GHz 2400~2483.5MHz
WIFI 802.11g (Harmonic @ 3m)

Table with 14 columns: WIFI Ant. 1, Note, Frequency (MHz), Level (dBµV/m), Over Limit (dB), Limit Line (dBµV/m), Read Level (dBµV), Antenna Factor (dB/m), Cable Loss (dB), Preamp Factor (dB), Ant Pos (cm), Table Pos (deg), Peak Avg. (P/A), Pol. (H/V). Rows include channels CH 01, CH 02, CH 06, CH 10, and CH 11 with their respective frequency and measurement data.

Remark

- 1. No other spurious found.
2. All results are PASS against Peak and Average limit line.



**2.4GHz 2400~2483.5MHz
WIFI 802.11n HT20 (Band Edge @ 3m)**

| WIFI Ant. 1 | Note | Frequency (MHz) | Level (dBμV/m) | Over Limit (dB) | Limit Line (dBμV/m) | Read Level (dBμV) | Antenna Factor (dB/m) | Cable Loss (dB) | Preamp Factor (dB) | Ant Pos (cm) | Table Pos (deg) | Peak Avg. (P/A) | Pol. (H/V) |
|-------------------------------|---|-------------------|------------------|-------------------|-----------------------|---------------------|-------------------------|-------------------|----------------------|----------------|-------------------|-------------------|--------------|
| 802.11n HT20 CH 01 2412MHz | | 2390 | 62.61 | -11.39 | 74 | 67.04 | 27 | 5.59 | 37.02 | 326 | 198 | P | H |
| | ! | 2389.65 | 49.53 | -4.47 | 54 | 53.96 | 27 | 5.59 | 37.02 | 326 | 198 | A | H |
| | * | 2419.372 | 100.25 | - | - | 104.51 | 27.13 | 5.61 | 37 | 326 | 198 | P | H |
| | * | 2414.613 | 92.52 | - | - | 96.78 | 27.13 | 5.61 | 37 | 326 | 198 | A | H |
| | | 2387.76 | 54.59 | -19.41 | 74 | 59.02 | 27 | 5.59 | 37.02 | 100 | 22 | P | V |
| | | 2388.39 | 44.4 | -9.6 | 54 | 48.83 | 27 | 5.59 | 37.02 | 100 | 22 | A | V |
| | * | 2413.11 | 93.13 | - | - | 97.39 | 27.13 | 5.61 | 37 | 100 | 22 | P | V |
| | * | 2413.36 | 85.63 | - | - | 89.89 | 27.13 | 5.61 | 37 | 100 | 22 | A | V |
| 802.11n HT20 CH 06 2437MHz | * | 2442.585 | 101.73 | - | - | 105.66 | 27.39 | 5.65 | 36.97 | 163 | 217 | P | H |
| | * | 2442.668 | 94.67 | - | - | 98.6 | 27.39 | 5.65 | 36.97 | 163 | 217 | A | H |
| | * | 2443.503 | 97.13 | - | - | 101.06 | 27.39 | 5.65 | 36.97 | 249 | 46 | P | V |
| | * | 2442.167 | 90.33 | - | - | 94.26 | 27.39 | 5.65 | 36.97 | 249 | 46 | A | V |
| 802.11n HT20 CH 11 2462MHz | * | 2469.889 | 101.13 | - | - | 104.91 | 27.51 | 5.67 | 36.96 | 307 | 221 | P | H |
| | * | 2465.631 | 93.7 | - | - | 97.48 | 27.51 | 5.67 | 36.96 | 307 | 221 | A | H |
| | | 2484.72 | 62 | -12 | 74 | 65.61 | 27.64 | 5.69 | 36.94 | 307 | 221 | P | H |
| | ! | 2483.92 | 50.01 | -3.99 | 54 | 53.62 | 27.64 | 5.69 | 36.94 | 307 | 221 | A | H |
| | * | 2467.885 | 98.9 | - | - | 102.68 | 27.51 | 5.67 | 36.96 | 100 | 73 | P | V |
| | * | 2465.631 | 91.31 | - | - | 95.09 | 27.51 | 5.67 | 36.96 | 100 | 73 | A | V |
| | | 2486.16 | 59.18 | -14.82 | 74 | 62.79 | 27.64 | 5.69 | 36.94 | 100 | 73 | P | V |
| | 2485.24 | 47.67 | -6.33 | 54 | 51.28 | 27.64 | 5.69 | 36.94 | 100 | 73 | A | V | |
| Remark | 1. No other spurious found. 2. All results are PASS against Peak and Average limit line. | | | | | | | | | | | | |



**2.4GHz 2400~2483.5MHz
WIFI 802.11n HT20 (Harmonic @ 3m)**

| WIFI Ant. 1 | Note | Frequency (MHz) | Level (dBμV/m) | Over Limit (dB) | Limit Line (dBμV/m) | Read Level (dBμV) | Antenna Factor (dB/m) | Cable Loss (dB) | Preamp Factor (dB) | Ant Pos (cm) | Table Pos (deg) | Peak Avg. (P/A) | Pol. (H/V) |
|-------------------------------|---|-------------------|------------------|-------------------|-----------------------|---------------------|-------------------------|-------------------|----------------------|----------------|-------------------|-----------------|------------|
| 802.11n HT20 CH 01 2412MHz | | 4824 | 42.97 | -31.03 | 74 | 40.29 | 31.51 | 7.85 | 36.68 | 128 | 317 | P | H |
| | | 4824 | 44.17 | -29.83 | 74 | 41.49 | 31.51 | 7.85 | 36.68 | 162 | 219 | P | V |
| 802.11n HT20 CH 06 2437MHz | | 4875 | 42.31 | -31.69 | 74 | 39.49 | 31.59 | 7.89 | 36.66 | 100 | 360 | P | H |
| | | 7311 | 45.91 | -28.09 | 74 | 38.99 | 34.03 | 9.58 | 36.69 | 100 | 0 | P | H |
| | | 4875 | 42.08 | -31.92 | 74 | 39.26 | 31.59 | 7.89 | 36.66 | 100 | 360 | P | V |
| | | 7311 | 45.45 | -28.55 | 74 | 38.53 | 34.03 | 9.58 | 36.69 | 100 | 0 | P | V |
| 802.11n HT20 CH 11 2462MHz | | 4924 | 42.54 | -31.46 | 74 | 39.6 | 31.67 | 7.92 | 36.65 | 164 | 81 | P | H |
| | | 7386 | 44.51 | -29.49 | 74 | 37.24 | 34.29 | 9.76 | 36.78 | 259 | 133 | P | H |
| | | 4923 | 43.58 | -30.42 | 74 | 40.64 | 31.67 | 7.92 | 36.65 | 138 | 274 | P | V |
| | | 7386 | 45.07 | -28.93 | 74 | 37.8 | 34.29 | 9.76 | 36.78 | 128 | 197 | P | V |
| Remark | 1. No other spurious found. 2. All results are PASS against Peak and Average limit line. | | | | | | | | | | | | |



**2.4GHz 2400~2483.5MHz
WIFI 802.11n HT40 (Band Edge @ 3m)**

| WIFI Ant. 1 | Note | Frequency (MHz) | Level (dBμV/m) | Over Limit (dB) | Limit Line (dBμV/m) | Read Level (dBμV) | Antenna Factor (dB/m) | Cable Loss (dB) | Preamp Factor (dB) | Ant Pos (cm) | Table Pos (deg) | Peak Avg. (P/A) | Pol. (H/V) |
|----------------------------|------|-------------------|------------------|-------------------|-----------------------|---------------------|-------------------------|-------------------|----------------------|----------------|-------------------|-------------------|--------------|
| 802.11n HT40 CH 03 2422MHz | | 2388.66 | 61.53 | -12.47 | 74 | 65.96 | 27 | 5.59 | 37.02 | 100 | 235 | P | H |
| | ! | 2388.75 | 49.49 | -4.51 | 54 | 53.92 | 27 | 5.59 | 37.02 | 100 | 235 | A | H |
| | * | 2434.068 | 98.84 | - | - | 102.94 | 27.26 | 5.63 | 36.99 | 100 | 235 | P | H |
| | * | 2439.329 | 91.24 | - | - | 95.17 | 27.39 | 5.65 | 36.97 | 100 | 235 | A | H |
| | | 2483.72 | 62.09 | -11.91 | 74 | 65.7 | 27.64 | 5.69 | 36.94 | 100 | 235 | P | H |
| | ! | 2484.2 | 50.01 | -3.99 | 54 | 53.62 | 27.64 | 5.69 | 36.94 | 100 | 235 | A | H |
| | | 2388.66 | 56.03 | -17.97 | 74 | 60.46 | 27 | 5.59 | 37.02 | 371 | 84 | P | V |
| | | 2387.4 | 44.97 | -9.03 | 54 | 49.4 | 27 | 5.59 | 37.02 | 371 | 84 | A | V |
| | * | 2438.159 | 95.63 | - | - | 99.56 | 27.39 | 5.65 | 36.97 | 371 | 84 | P | V |
| | * | 2436.74 | 87.92 | - | - | 91.85 | 27.39 | 5.65 | 36.97 | 371 | 84 | A | V |
| | | 2483.64 | 57.31 | -16.69 | 74 | 60.92 | 27.64 | 5.69 | 36.94 | 371 | 84 | P | V |
| | | 2483.96 | 46.31 | -7.69 | 54 | 49.92 | 27.64 | 5.69 | 36.94 | 371 | 84 | A | V |
| 802.11n HT40 CH 06 2437MHz | | 2390 | 53.51 | -20.49 | 74 | 57.94 | 27 | 5.59 | 37.02 | 100 | 235 | P | H |
| | | 2390 | 43.22 | -10.78 | 54 | 47.65 | 27 | 5.59 | 37.02 | 100 | 235 | A | H |
| | * | 2439.412 | 99.54 | - | - | 103.47 | 27.39 | 5.65 | 36.97 | 100 | 235 | P | H |
| | * | 2442.835 | 91.79 | - | - | 95.72 | 27.39 | 5.65 | 36.97 | 100 | 235 | A | H |
| | | 2484.2 | 63.09 | -10.91 | 74 | 66.7 | 27.64 | 5.69 | 36.94 | 100 | 235 | P | H |
| | ! | 2483.76 | 51.82 | -2.18 | 54 | 55.43 | 27.64 | 5.69 | 36.94 | 100 | 235 | A | H |
| | | 2355.81 | 51.21 | -22.79 | 74 | 55.78 | 26.91 | 5.54 | 37.02 | 100 | 156 | P | V |
| | | 2385.87 | 42.49 | -11.51 | 54 | 46.92 | 27 | 5.59 | 37.02 | 100 | 156 | A | V |
| | * | 2444.004 | 91.85 | - | - | 95.78 | 27.39 | 5.65 | 36.97 | 100 | 156 | P | V |
| | * | 2447.01 | 83.52 | - | - | 87.45 | 27.39 | 5.65 | 36.97 | 100 | 156 | A | V |
| | | 2489.8 | 55.54 | -18.46 | 74 | 58.99 | 27.77 | 5.71 | 36.93 | 100 | 156 | P | V |
| | | 2493.16 | 44.56 | -9.44 | 54 | 48.01 | 27.77 | 5.71 | 36.93 | 100 | 156 | A | V |



| | | | | | | | | | | | | | |
|---|---|----------|--------|--------|----|--------|-------|------|-------|-----|----|---|---|
| 802.11n HT40 CH 09 2452MHz | | 2364.99 | 51.08 | -22.92 | 74 | 55.65 | 26.91 | 5.54 | 37.02 | 114 | 56 | P | H |
| | | 2377.5 | 42.55 | -11.45 | 54 | 47.05 | 26.95 | 5.57 | 37.02 | 114 | 56 | A | H |
| | * | 2450.1 | 100.24 | - | - | 104.17 | 27.39 | 5.65 | 36.97 | 114 | 56 | P | H |
| | * | 2457.198 | 92.52 | - | - | 96.3 | 27.51 | 5.67 | 36.96 | 114 | 56 | A | H |
| | | 2484.12 | 63.64 | -10.36 | 74 | 67.25 | 27.64 | 5.69 | 36.94 | 114 | 56 | P | H |
| | ! | 2489.44 | 50.63 | -3.37 | 54 | 54.08 | 27.77 | 5.71 | 36.93 | 114 | 56 | A | H |
| | | 2344.92 | 51 | -23 | 74 | 55.63 | 26.86 | 5.52 | 37.01 | 368 | 94 | P | V |
| | | 2375.43 | 42.67 | -11.33 | 54 | 47.17 | 26.95 | 5.57 | 37.02 | 368 | 94 | A | V |
| | * | 2468.052 | 96.11 | - | - | 99.89 | 27.51 | 5.67 | 36.96 | 368 | 94 | P | V |
| | * | 2465.882 | 88.91 | - | - | 92.69 | 27.51 | 5.67 | 36.96 | 368 | 94 | A | V |
| | | 2490.04 | 58.68 | -15.32 | 74 | 62.13 | 27.77 | 5.71 | 36.93 | 368 | 94 | P | V |
| | | 2483.96 | 46.33 | -7.67 | 54 | 49.94 | 27.64 | 5.69 | 36.94 | 368 | 94 | A | V |
| Remark | 1. No other spurious found. 2. All results are PASS against Peak and Average limit line. | | | | | | | | | | | | |



2.4GHz 2400~2483.5MHz
WIFI 802.11n HT40 (Harmonic @ 3m)

Table with 14 columns: WIFI Ant. 1, Note, Frequency (MHz), Level (dBµV/m), Over Limit (dB), Limit Line (dBµV/m), Read Level (dBµV), Antenna Factor (dB/m), Cable Loss (dB), Preamp Factor (dB), Ant Pos (cm), Table Pos (deg), Peak Avg. (P/A), Pol. (H/V). Rows include data for 802.11n HT40 CH 03 (2422MHz) and CH 06 (2437MHz), and 802.11n HT40 CH 09 (2452MHz).

Remark

- 1. No other spurious found.
2. All results are PASS against Peak and Average limit line.



Emission below 1GHz

2.4GHz WIFI 802.11n HT40 (LF)

| WIFI | Note | Frequency | Level | Over | Limit | Read | Antenna | Cable | Preamp | Ant | Table | Peak | Pol. |
|---------------------------------|--|-----------|------------|--------|------------|----------|----------|--------|--------|--------|---------|---------|---------|
| Ant. | | | | Limit | Line | Level | Factor | Loss | Factor | Pos | Pos | Avg. | |
| 1 | | (MHz) | (dBμV/m) | (dB) | (dBμV/m) | (dBμV) | (dB/m) | (dB) | (dB) | (cm) | (deg) | (P/A) | (H/V) |
| 2.4GHz 802.11n HT40 LF | | 31.94 | 18.4 | -21.6 | 40 | 31.94 | 18.22 | 0.79 | 32.55 | - | - | P | H |
| | | 39.7 | 18.65 | -21.35 | 40 | 36.12 | 14.3 | 0.79 | 32.56 | 100 | 214 | P | H |
| | | 159.98 | 10.49 | -33.01 | 43.5 | 30.13 | 11.33 | 1.44 | 32.41 | - | - | P | H |
| | | 278.32 | 21.29 | -24.71 | 46 | 38.89 | 12.61 | 1.9 | 32.11 | - | - | P | H |
| | | 359.8 | 17.83 | -28.17 | 46 | 32.67 | 15.29 | 2.15 | 32.28 | - | - | P | H |
| | | 935.98 | 21.88 | -24.12 | 46 | 27.84 | 21.9 | 3.57 | 31.43 | - | - | P | H |
| | | 31.94 | 27.58 | -12.42 | 40 | 41.12 | 18.22 | 0.79 | 32.55 | 100 | 219 | P | V |
| | | 38.73 | 25.43 | -14.57 | 40 | 42.39 | 14.79 | 0.79 | 32.54 | - | - | P | V |
| | | 53.28 | 21.08 | -18.92 | 40 | 44.92 | 7.92 | 0.79 | 32.55 | - | - | P | V |
| | | 510.15 | 16.41 | -29.59 | 46 | 28.42 | 17.45 | 2.64 | 32.1 | - | - | P | V |
| | | 651.77 | 19.39 | -26.61 | 46 | 28.69 | 19.42 | 2.92 | 31.64 | - | - | P | V |
| | 945.68 | 22.06 | -23.94 | 46 | 28.07 | 21.69 | 3.68 | 31.38 | - | - | P | V | |
| Remark | 1. No other spurious found. 2. All results are PASS against limit line. | | | | | | | | | | | | |



Note symbol

| | |
|-----|--|
| * | Fundamental Frequency which can be ignored. However, the level of any unwanted emissions shall not exceed the level of the fundamental frequency. |
| ! | Test result is over limit line. |
| P/A | Peak or Average |
| H/V | Horizontal or Vertical |



A calculation example for radiated spurious emission is shown as below:

| WIFI | Note | Frequency | Level | Over | Limit | Read | Antenna | Cable | Preamp | Ant | Table | Peak | Pol. |
|---------|------|-----------|------------|--------|------------|----------|----------|--------|--------|--------|---------|---------|---------|
| Ant. | | | | Limit | Line | Level | Factor | Loss | Factor | Pos | Pos | Avg. | |
| 1 | | (MHz) | (dBμV/m) | (dB) | (dBμV/m) | (dBμV) | (dB/m) | (dB) | (dB) | (cm) | (deg) | (P/A) | (H/V) |
| 802.11b | | 2390 | 55.45 | -18.55 | 74 | 54.51 | 32.22 | 4.58 | 35.86 | 103 | 308 | P | H |
| CH 01 | | | | | | | | | | | | | |
| 2412MHz | | 2390 | 43.54 | -10.46 | 54 | 42.6 | 32.22 | 4.58 | 35.86 | 103 | 308 | A | H |

- Level(dBμV/m) =
Antenna Factor(dB/m) + Cable Loss(dB) + Read Level(dBμV) - Preamp Factor(dB)
- Over Limit(dB) = Level(dBμV/m) – Limit Line(dBμV/m)

For Peak Limit @ 2390MHz:

- Level(dBμV/m)
= Antenna Factor(dB/m) + Cable Loss(dB) + Read Level(dBμV) - Preamp Factor(dB)
= 32.22(dB/m) + 4.58(dB) + 54.51(dBμV) – 35.86 (dB)
= 55.45 (dBμV/m)
- Over Limit(dB)
= Level(dBμV/m) – Limit Line(dBμV/m)
= 55.45(dBμV/m) – 74(dBμV/m)
= -18.55(dB)

For Average Limit @ 2390MHz:

- Level(dBμV/m)
= Antenna Factor(dB/m) + Cable Loss(dB) + Read Level(dBμV) - Preamp Factor(dB)
= 32.22(dB/m) + 4.58(dB) + 42.6(dBμV) – 35.86 (dB)
= 43.54 (dBμV/m)
- Over Limit(dB)
= Level(dBμV/m) – Limit Line(dBμV/m)
= 43.54(dBμV/m) – 54(dBμV/m)
= -10.46(dB)

Both peak and average measured complies with the limit line, so test result is “PASS”.