

# EMI TEST REPORT

## FCC CERTIFICATION

**Applicant:**

LG Electronics MobileComm U.S.A., Inc.  
1000 Sylvan Avenue, Englewood Cliffs NJ 07632  
United States

**Date of Receipt: September 27, 2017****Date of Issue: October 13, 2017****Test Report No. HCT-E-1710-F002****FCC ID :****ZNFX210MA****Rule Part(s) / Standard(s):** FCC CFR 47 PART 15 Subpart B Class B**FCC Classification:** JBP (Part 15 B – Class B Computing Device Peripheral)**EUT Type:** Multi-band GSM/WCDMA/LTE Phone with WLAN, Bluetooth**Model Name:** LM-X210MA**Additional Model Name:** LM-X210TAT, LMX210TAT, X210TAT, LMX210MA, X210MA,  
LM-X210TA, LMX210TA, X210TA**Date of Test:** October 07, 2017 – October 09, 2017

The device bearing the trade name and model specified above, has been shown to comply with the applicable technical standards as indicated in the measurement report and was tested in accordance with the measurement procedures specified in ANSI C63.4-2014. (See Test Report if any modifications were made for compliance)

I attest to the accuracy of data. All measurements reported herein were performed by me or were made under my supervision and are correct to the best of my knowledge and belief. I assume full responsibility for the completeness of these measurements and vouch for the qualifications of all persons taking them.

HCT certifies that no party to application has been denied the FCC benefits pursuant to Section 5301 of the Anti-Drug Abuse Act of 1988, 21 U.S.C 862

**Tested By**

**Dong-Hwan Seo**  
Test Engineer  
EMC Team  
Certification Division

**Reviewed By**

**Jin-Pyo Hong**  
Technical Manager  
EMC Team  
Certification Division

This report only responds to the tested sample and may not be reproduced, except in full, without written approval of the HCT Co., Ltd.



## REVISION HISTORY

*The revision history for this document is shown in table.*

Version	Issue Date	Description
HCT-E-1710-F002	October 13, 2017	Initial Release



## TABLE OF CONTENTS

	<b>PAGE</b>
1. GENERAL INFORMATION .....	4
1.1 Description of EUT .....	4
1.2 Related Submittal(s) / Grant(s) .....	5
1.3 Test Facility .....	5
1.4 Calibration of Measuring Instrument .....	5
1.5 Tested System Details .....	6
1.6 Cable Description .....	7
1.7 Noise Suppression Parts on Cable. (I/O Cable) .....	7
2. MEASUREMENT UNCERTAINTY .....	8
3. DESCRIPTION OF TEST .....	9
3.1 Measurement of Conducted Emission .....	9
3.2 Measurement of Radiated Measurements .....	10
4. PRELIMINARY TEST .....	12
4.1 Conducted Emission Test .....	12
4.2 Radiated Emission Test .....	12
5. CONDUCTED AND RADIATED EMISSION TEST SUMMARY .....	13
5.1 Conducted Emission Test .....	13
5.2 Radiated Emission Test .....	20
6. LIST OF TEST EQUIPMENT .....	22
7. CONCLUSION .....	23
8. APPENDIX A_ TEST SETUP PHOTOGRAPHS .....	24



## 1. GENERAL INFORMATION

### 1.1 Description of EUT

Its basic purpose is used for communications.

FCC ID	ZNFX210MA
Model	LM-X210MA
Additional Model	LM-X210TAT, LMX210TAT, X210TAT, LMX210MA, X210MA, LM-X210TA, LMX210TA, X210TA
EUT Type	Multi-band GSM/WCDMA/LTE Phone with WLAN, Bluetooth
TX Frequency	824.20 MHz to 848.80 MHz (GSM 850) 1 850.20 MHz to 1 909.80 MHz (GSM 1 900) 826.40 MHz to 846.60 MHz (WCDMA B5) 1 852.4 MHz to 1 907.6 MHz (WCDMA B2) 1712.4 MHz to 1752.6 MHz (WCDMA B4) 1 850 MHz to 1 910 MHz (LTE B2) 1 710 MHz to 1 755 MHz (LTE B4) 824 MHz to 849 MHz (LTE B5) 699 MHz to 716 MHz (LTE B12) 1 710 MHz to 1 780 MHz (LTE B66) 2 402 MHz to 2 480 MHz (Bluetooth) 2 412 MHz to 2 462 MHz (WiFi 2.4 GHz) 5 180 MHz to 5 240 MHz (WiFi 5 GHz_UNII 1) 5 260 MHz to 5 320 MHz (WiFi 5 GHz_UNII 2A) 5 500 MHz to 5 720 MHz (WiFi 5 GHz_UNII 2C) 5 745 MHz to 5 825 MHz (WiFi 5 GHz_UNII 3)
RX Frequency	869.20 MHz to 893.80 MHz (GSM 850) 1 930.20 MHz to 1 989.80 MHz (GSM 1 900) 871.40 MHz to 891.60 MHz (WCDMA B5) 1 932.4 MHz to 1 987.6 MHz (WCDMA B2) 2 112.4 MHz to 2 152.6 MHz (WCDMA B4) 1 930 MHz to 1 990 MHz (LTE B2) 2 110 MHz to 2 155 MHz (LTE B4) 869 MHz to 894 MHz (LTE B5) 729 MHz to 746 MHz (LTE B12) 2 110 MHz to 2 200 MHz (LTE B66) 2 402 MHz to 2 480 MHz (Bluetooth) 2 412 MHz to 2 462 MHz (WiFi 2.4 GHz) 5 180 MHz to 5 240 MHz (WiFi 5 GHz_UNII 1) 5 260 MHz to 5 320 MHz (WiFi 5 GHz_UNII 2A) 5 500 MHz to 5 720 MHz (WiFi 5 GHz_UNII 2C) 5 745 MHz to 5 825 MHz (WiFi 5 GHz_UNII 3)



## 1.2 Related Submittal(s) / Grant(s)

Original submittal only.

## 1.3 Test Facility

Test site is located at 74, SEOICHEON-RO, 578BEON-GIL, MAJANG-MYEON, ICHEON-SI, GYEONGGI-DO, SOUTH KOREA. Those measurement facilities are constructed in conformance with the requirements of ANSI C63.4-2014.

Measurement Facilities	Registration Number
Radiated Field strength measurement facility 3 m Semi Anechoic chamber	90661 (July 07, 2015)
Radiated Field strength measurement facility 10 m Semi Anechoic chamber	

## 1.4 Calibration of Measuring Instrument

The measuring equipment, which was utilized in performing the tests documented herein, has been calibrated in accordance with the manufacturers recommendations for utilizing calibration equipments, which is traceable to recognized national standards.

Especially, all antenna for measurement is calibrated in accordance with the requirements of C63.5 (Version : 2006).



## 1.5 Tested System Details

All equipment descriptions used in the tested system (including inserted cards) are:

Device Type	Model Name	Serial Number	Manufacturer	FCC ID / DoC
EUT	LM-X210MA	-	LG	ZNFX210MA
Data cable	EAD62377921	-	LEAGTECH	-
Earphone	EAB64168751	-	I-Sound	-
Notebook PC	ProBook6560b	5CB2053MXF	HP	DoC
Notebook PC adaptor	Series PPP009L-E	-	LITE-On Technology	-
RJ45 cable	-	-	-	-
Gateway	TL-WR747N	-	TP-LINK	-
Gateway adaptor	T120150-2H1	-	TP-LINK	-
Serial mouse	Serial 2 button mouse	02031069	Radio shack	FSUGMZE3
Micro SD card	SanDisk Extreme 32 GB SD Card	-	SanDisk	-



## 1.6 Cable Description

Product Name	Port	Power Cord Shielded (Y/N)	I/O Cable Shielded (Y/N)	Length (m)
EUT	Micro USB	Y	Y	(P,D)1.0
	Earphone	N/A	Y	(D)1.2
Notebook PC	RJ 45	N/A	N	(D)1.6
	Serial (Mouse)	N/A	Y	(D)1.8
	DC in	N	N/A	(P)1.8
Gateway	DC in	N	N/A	(P)1.8

\* The marked “(D)” means the data cable and “(P)” means the power cable.

## 1.7 Noise Suppression Parts on Cable. (I/O Cable)

Product Name	Port	Ferrite Bead (Y/N)	Location	Metal Hood (Y/N)	Location
EUT	Micro USB	N	N/A	Y	Both End
	Earphone	N	N/A	Y	EUT End
Notebook PC	RJ 45	N	N/A	N	N/A
	Serial (Mouse)	N	N/A	Y	Notebook PC End



## 2. MEASUREMENT UNCERTAINTY

The measurement uncertainties shown below were calculated in accordance with the requirements of ANSI C63.4-2014.

All measurement uncertainty values are shown with a coverage factor of  $k = 2$  to indicate a 95 % level of confidence. The measurement data shown herein meets or exceeds the  $U_{\text{CISPR}}$  measurement uncertainty values specified in CISPR 16-4-2 and, thus, can be compared directly to specified limits to determine compliance.

Parameter	Expanded Uncertainty (dB)
Conducted Emission (0.15 MHz to 30 MHz)	1.82 dB ( $k = 2$ )
Radiated Emissions (30 MHz to 1 GHz)	5.20 dB ( $k = 2$ )
Radiated Emissions (1 GHz to 18 GHz)	5.24 dB ( $k = 2$ )
Radiated Emissions (18 GHz to 40 GHz)	5.40 dB ( $k = 2$ )





### 3. DESCRIPTION OF TEST

#### 3.1 Measurement of Conducted Emission

The test procedure was in accordance with ANSI C63.4-2014, Clause 7.3

- a. The EUT was placed 0.4 meters from the conducting wall of the shielded room with EUT being connected to the power mains through a line impedance stabilization network (LISN).  
If the EUT is connected to the PC through USB, the AC power-line adapter of the PC is directly connected to a line impedance stabilization network (LISN).  
Other support units were connected to the power mains through another LISN. The two LISNs provide 50 Ohm/ 50uH of coupling impedance for the measuring instrument.
- b. Both conducted lines are measured in Quasi-Peak and Average mode, including the worst-case data points for each tested configuration.
- c. The frequency range from 150 kHz to 30 MHz was searched.

#### [ Conducted Emission Limits ]

Frequency (MHz)	Resolution Bandwidth (kHz)	Quasi-Peak (dB(μV))	Average (dB(μV))
0.15 to 0.5	9	66 to 56*	56 to 46*
0.5 to 5	9	56	46
5 to 30	9	60	50

*\*Decreases with the logarithm of the frequency.*



### 3.2 Measurement of Radiated Emission

The test procedure was in accordance with ANSI C63.4-2014, Clause 8.3

- a. The EUT was placed on the top of a turn table 0.8 meters above the ground at a semi-anechoic chamber. The table was rotated 360 degrees to determine the position of the highest radiation.
- b. The EUT was set 3 m away from the interference-receiving antenna, which was mounted on the top of a variable-height antenna tower.
- c. The antenna height is varied from 1 m to 4 m above the ground to determine the maximum value of the field strength. Both horizontal and vertical polarizations of the antenna are set to make the measurement.
- d. For each suspected emission, the EUT was arranged to its worst case and then the antenna was tuned to heights from 1 m to 4 m and the turn table was turned from 0 degrees to 360 degrees to find the maximum reading.
- e. The test-receiver system was set to Quasi-Peak detect function and specified bandwidth with maximum hold mode when the test frequency is below 1 GHz.
- f. The test-receiver system was set to Peak and Average detect function and specified bandwidth with maximum hold mode when the test frequency is above 1 GHz.
- g. Place the measurement antenna away from each area of the EUT determined to be a source of emissions at the specified measurement distance, while keeping the measurement antenna aimed at the source of emissions at each frequency of significant emissions, with polarization oriented for maximum response.(1 GHz to 40 GHz)

#### [ Radiated Emission Limits ]

Frequency (MHz)	Antenna Distance (m)	Field Strength (μV/m)	Quasi-Peak (dB(μV)/m)
30 to 88	3	100	40.0
88 to 216	3	150	43.5
216 to 960	3	200	46.0
Above 960	3	500	54.0
Frequency (MHz)	Antenna Distance (m)	Peak (dB(μV)/m)	Average (dB(μV)/m)
Above 1 000	3	74	54



### 3.2.1 Frequency Range of Radiated Measurements

An unintentional radiator, including a digital device, the spectrum shall be investigated from the lowest radio frequency signal generated or used in the device, without going below the lowest frequency for which a Radiated Emission limit is specified, up to the frequency shown in the following table

Highest frequency generated or used in the device or on which the device operates or tunes (MHz)	Upper frequency of measurement range (MHz)
Below 1.705	30
1.705 to 108	1 000
108 to 500	2 000
500 to 1 000	5 000
Above 1 000	5 <sup>th</sup> harmonic of the highest frequency or 40 GHz, whichever is lower

### 3.3 Configuration of Tested System

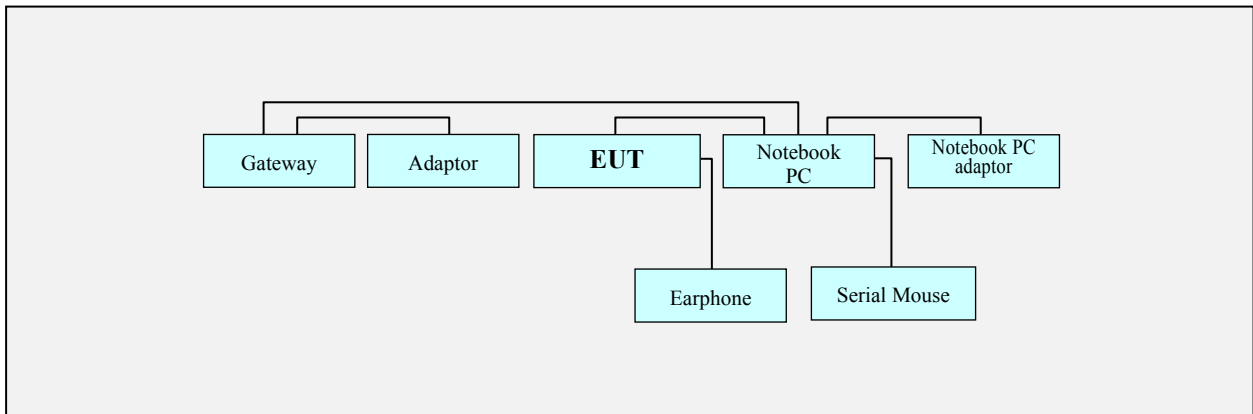

**Non-Conductive Table**  
 Power Line: 120 VAC, 60 Hz



## 4. PRELIMINARY TEST

### 4.1 Conducted Emission Test

It was tested Data Communication mode, after connecting all peripheral devices.

**Operation Mode:**       Data Communication mode

### 4. 2 Radiated Emission Test

It was tested Data Communication mode, after connecting all peripheral devices.

**Operation Mode:**       Data Communication mode



## 5. CONDUCTED AND RADIATED EMISSION TEST SUMMARY

### 5.1 Conducted Emission Test

The test results of conducted emission at mains ports provide the following information:

Rule Part / Standard	FCC PART 15 Subpart B Class B
Detector	Quasi-Peak, CISPR-Average
Bandwidth	9 kHz (6 dB)
Operation Mode	Data Communication mode
Kind of Test Site	Shielded Room
Temperature	23.0 °C
Relative Humidity	59.4 %
Test Date	October 09, 2017

#### ***- Calculation Formula:***

1. Conductor L1 = Hot, Conductor N = Neutral
2. Corr. = LISN Factor + Cable Loss
3. QuasiPeak or CAverage= Receiver Reading + Corr.
4. Margin = Limit – QuasiPeak or CAverage



Figure 1: Conducted Emission, AC Main Port, Data Communication Mode, Line (L1)

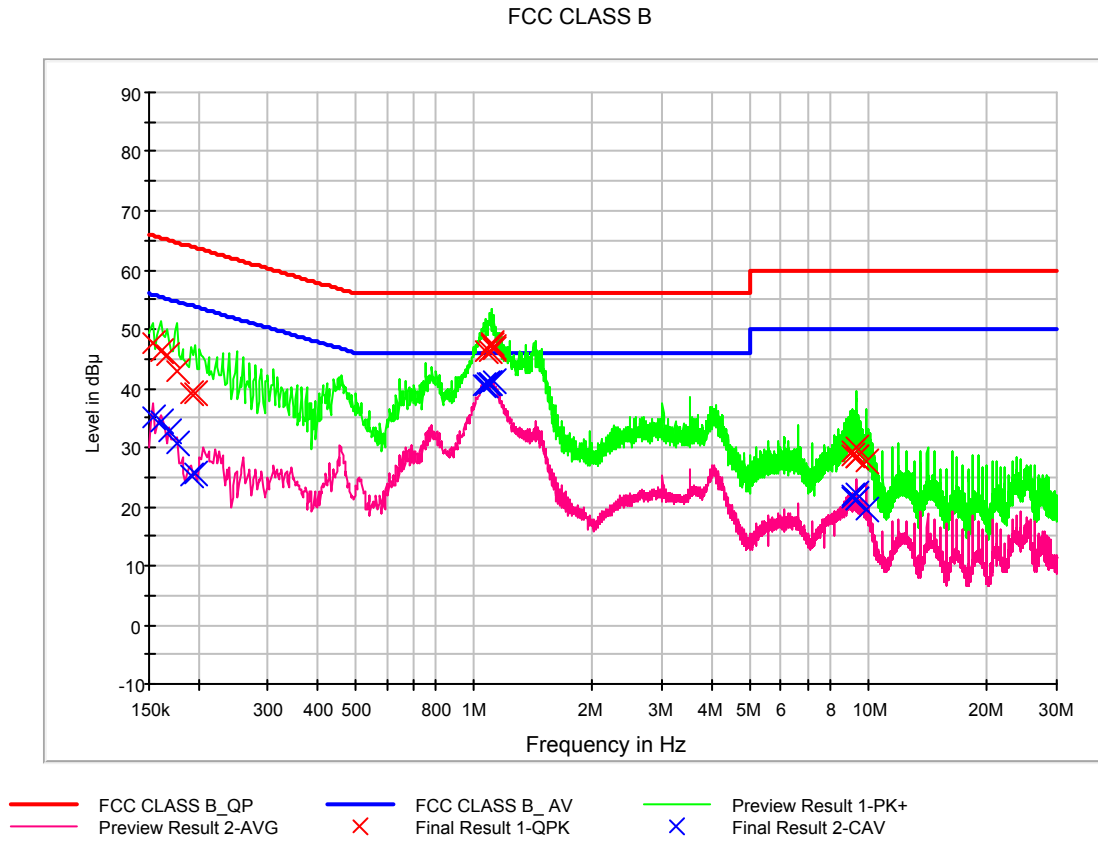



### QuasiPeak Final Result, Line (L1)

Frequency (MHz)	QuasiPeak (dBuV)	Bandwidth (kHz)	Line	Corr. (dB)	Margin (dB)	Limit (dBuV)
0.154000	47.5	9.000	L1	9.6	18.3	65.8
0.160000	46.4	9.000	L1	9.6	19.0	65.5
0.166000	45.7	9.000	L1	9.6	19.5	65.2
0.176000	42.8	9.000	L1	9.6	21.9	64.7
0.192000	39.2	9.000	L1	9.6	24.8	63.9
0.196000	39.1	9.000	L1	9.6	24.7	63.8
1.066000	46.3	9.000	L1	9.7	9.7	56.0
1.092000	46.4	9.000	L1	9.7	9.6	56.0
1.106000	47.4	9.000	L1	9.7	8.6	56.0
1.114000	47.5	9.000	L1	9.7	8.5	56.0
1.118000	46.8	9.000	L1	9.7	9.2	56.0
1.124000	46.8	9.000	L1	9.7	9.2	56.0
9.094000	29.4	9.000	L1	10.0	30.6	60.0
9.142000	28.7	9.000	L1	10.0	31.3	60.0
9.268000	28.4	9.000	L1	10.0	31.6	60.0
9.298000	29.9	9.000	L1	10.0	30.1	60.0
9.302000	28.3	9.000	L1	10.0	31.7	60.0
9.836000	27.5	9.000	L1	10.1	32.5	60.0



### CAverage Final Result, Line (L1)

Frequency (MHz)	CAverage (dBuV)	Bandwidth (kHz)	Line	Corr. (dB)	Margin (dB)	Limit (dBuV)
0.154000	35.0	9.000	L1	9.6	20.8	55.8
0.160000	34.3	9.000	L1	9.6	21.1	55.5
0.168000	32.7	9.000	L1	9.6	22.4	55.1
0.176000	30.6	9.000	L1	9.6	24.1	54.7
0.192000	25.4	9.000	L1	9.6	28.6	53.9
0.196000	25.6	9.000	L1	9.6	28.2	53.8
1.060000	40.5	9.000	L1	9.7	5.5	46.0
1.068000	40.5	9.000	L1	9.7	5.5	46.0
1.086000	41.0	9.000	L1	9.7	5.0	46.0
1.092000	40.7	9.000	L1	9.7	5.3	46.0
1.098000	41.0	9.000	L1	9.7	5.0	46.0
1.116000	41.1	9.000	L1	9.7	4.9	46.0
9.094000	21.5	9.000	L1	10.0	28.5	50.0
9.142000	21.8	9.000	L1	10.0	28.2	50.0
9.268000	22.1	9.000	L1	10.0	27.9	50.0
9.298000	21.1	9.000	L1	10.0	28.9	50.0
9.302000	21.2	9.000	L1	10.0	28.8	50.0
9.836000	19.6	9.000	L1	10.1	30.4	50.0





Figure 2: Conducted Emission, AC Main Port, Data Communication Mode, Line (N)

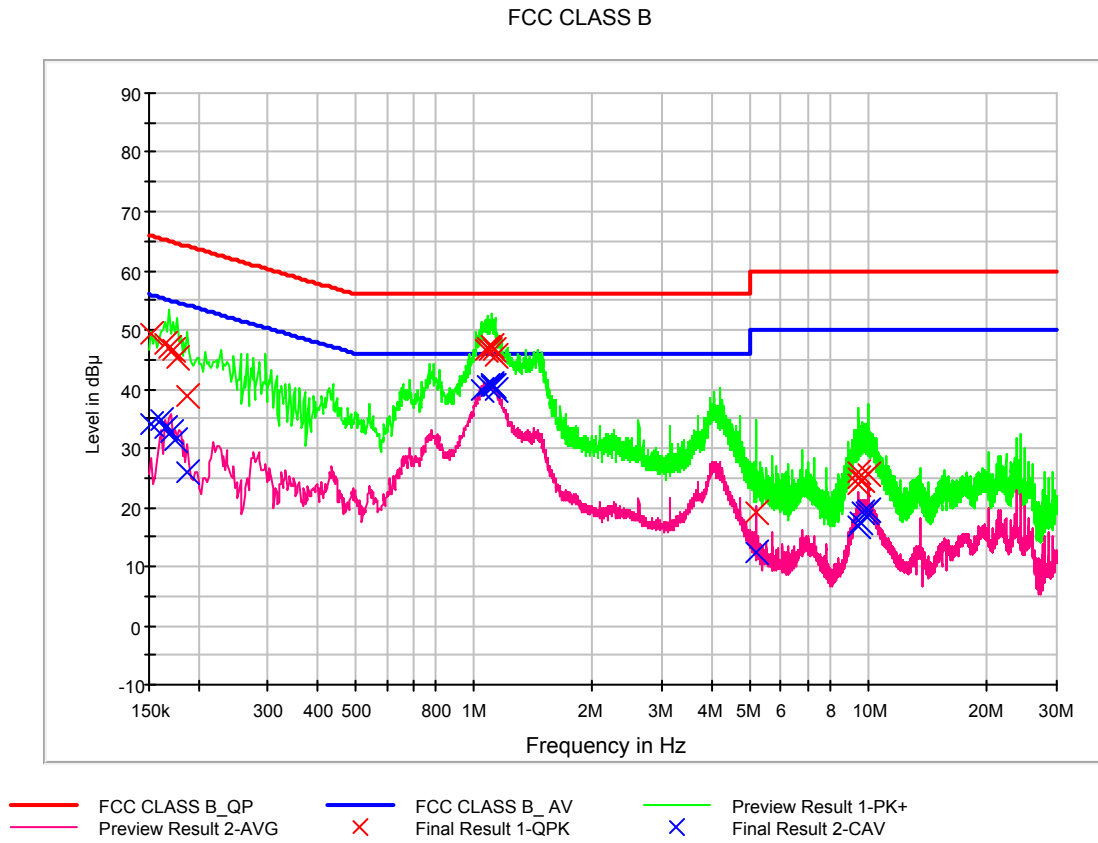



### QuasiPeak Final Result, Line (N)

Frequency (MHz)	QuasiPeak (dBuV)	Bandwidth (kHz)	Line	Corr. (dB)	Margin (dB)	Limit (dBuV)
0.152000	49.2	9.000	N	9.6	16.6	65.9
0.164000	47.7	9.000	N	9.6	17.6	65.3
0.168000	47.0	9.000	N	9.6	18.0	65.1
0.172000	46.5	9.000	N	9.6	18.4	64.9
0.176000	45.1	9.000	N	9.6	19.5	64.7
0.188000	38.9	9.000	N	9.6	25.2	64.1
1.064000	46.5	9.000	N	9.7	9.5	56.0
1.086000	47.1	9.000	N	9.7	8.9	56.0
1.092000	46.7	9.000	N	9.7	9.3	56.0
1.108000	47.2	9.000	N	9.7	8.8	56.0
1.120000	46.6	9.000	N	9.7	9.4	56.0
1.132000	45.7	9.000	N	9.7	10.3	56.0
5.190000	19.0	9.000	N	9.9	41.0	60.0
9.430000	24.8	9.000	N	10.1	35.2	60.0
9.440000	23.9	9.000	N	10.1	36.1	60.0
9.444000	25.9	9.000	N	10.1	34.1	60.0
9.610000	24.6	9.000	N	10.1	35.4	60.0
9.976000	25.5	9.000	N	10.1	34.5	60.0



## CAverage Final Result, Line (N)

Frequency (MHz)	CAverage (dBuV)	Bandwidth (kHz)	Line	Corr. (dB)	Margin (dB)	Limit (dBuV)
0.152000	33.9	9.000	N	9.6	21.9	55.9
0.160000	34.7	9.000	N	9.6	20.8	55.5
0.164000	33.6	9.000	N	9.6	21.7	55.3
0.170000	32.8	9.000	N	9.6	22.2	55.0
0.174000	31.5	9.000	N	9.6	23.3	54.8
0.188000	26.1	9.000	N	9.6	28.1	54.1
1.044000	39.7	9.000	N	9.7	6.3	46.0
1.080000	40.7	9.000	N	9.7	5.3	46.0
1.104000	40.6	9.000	N	9.7	5.4	46.0
1.110000	40.7	9.000	N	9.7	5.3	46.0
1.120000	40.4	9.000	N	9.7	5.6	46.0
1.132000	39.8	9.000	N	9.7	6.2	46.0
5.190000	12.4	9.000	N	9.9	37.6	50.0
9.440000	16.8	9.000	N	10.1	33.2	50.0
9.566000	17.6	9.000	N	10.1	32.4	50.0
9.672000	19.0	9.000	N	10.1	31.0	50.0
9.856000	19.0	9.000	N	10.1	31.0	50.0
9.976000	19.5	9.000	N	10.1	30.5	50.0



## 5.2 Radiated Emission Test

The test results of radiated emission provide the following information:

### -For Measurement Below 1 GHz

Rule Part / Standard	FCC PART 15 Subpart B Class B
Detector	Quasi-Peak
Bandwidth	120 kHz (6 dB)
Operation Mode	Data Communication mode
Kind of Test Site	3 m semi anechoic chamber
Temperature	23.8 °C
Relative Humidity	56.5 %
Test Date	October 08, 2017

Frequency (MHz)	Quasi Peak (dB $\mu$ V/m)	Antenna Height (cm)	POL. (H/V)	Azimuth (deg)	Corr. (dB)	Margin (dB)	Limit (dB $\mu$ V/m)
30.661798	28.7	100.0	V	24.0	21.8	11.3	40.0
47.801600	34.4	100.0	V	268.0	23.2	5.6	40.0
85.762400	30.8	250.0	H	315.0	18.1	9.2	40.0
125.000000	30.9	124.0	V	279.0	21.5	12.6	43.5
266.564000	35.1	125.0	H	150.0	22.8	10.9	46.0
374.996800	36.7	100.0	H	180.0	26.0	9.3	46.0

### - Calculation Formula:

1. POL. H = Horizontal, POL. V = Vertical
2. QuasiPeak = Reading (Receiver Reading) + Corr.
3. Corr. (Correction Factor) = Antenna Factor + Cable Loss
4. Margin = Limit - QuasiPeak



## -For Measurement Above 1 GHz

Rule Part / Standard	FCC PART 15 Subpart B Class B
Detector	Peak mode: Peak (RBW: 1 MHz, VBW: 3 MHz) CISPR-Average mode: Peak (RBW: 1 MHz, VBW: 10 Hz)
Highest Operating Frequency	5 825 MHz
Upper Frequency	1 GHz to 29.125 GHz
Operation Mode	Data Communication mode
Kind of Test Site	3 m semi anechoic chamber
Temperature	24.0 °C
Relative Humidity	55.6 %
Test Date	October 07, 2017

Frequency (MHz)	Peak (dB $\mu$ V/m)	Antenna Height (cm)	POL. (H/V)	Azimuth (deg)	Corr. (dB)	Margin (dB)	Limit (dB $\mu$ V/m)
1400.015000	48.3	319.5	V	234.0	-12.9	25.7	74.0
2078.490000	48.1	100.0	V	59.0	-11.5	25.9	74.0
2664.660000	49.1	99.8	V	3.0	-9.4	24.9	74.0
2999.680000	43.1	250.1	V	84.0	-8.7	30.9	74.0
4490.645000	41.3	250.2	V	15.0	-5.4	32.7	74.0
5994.125000	45.9	99.8	V	115.0	-2.2	28.1	74.0

Frequency (MHz)	CAverage (dB $\mu$ V/m)	Antenna Height (cm)	POL. (H/V)	Azimuth (deg)	Corr. (dB)	Margin (dB)	Limit (dB $\mu$ V/m)
1400.015000	47.0	319.5	V	234.0	-12.9	7.0	54.0
2078.490000	23.3	100.0	V	59.0	-11.5	30.7	54.0
2664.660000	24.0	99.8	V	3.0	-9.4	30.0	54.0
2999.680000	30.5	250.1	V	84.0	-8.7	23.5	54.0
4490.645000	27.2	250.2	V	15.0	-5.4	26.8	54.0
5994.125000	30.5	99.8	V	115.0	-2.2	23.5	54.0

### - Calculation Formula:

1. POL. H = Horizontal, POL. V = Vertical
2. Peak or CAverage = Reading (Receiver Reading) + Corr.
3. Corr. (Correction Factor) = Antenna Factor+ Cable Loss –Amplifier Gain
4. Margin = Limit - Peak or CAverage



## 6. LIST OF TEST EQUIPMENT

<u>Type</u>	<u>Manufacturer</u>	<u>Model Name</u>	<u>Serial Number</u>	<u>Calibration Cycle</u>	<u>CAL Date</u>
<u>Conducted Emission</u>					
<input type="checkbox"/> EMI Test Receiver	Rohde & Schwarz	ESCI	100584	1 year	06.20.2017
<input checked="" type="checkbox"/> EMI Test Receiver	Rohde & Schwarz	ESCI	100033	1 year	06.27.2017
<input checked="" type="checkbox"/> LISN	Rohde & Schwarz	ESH3-Z5	100282	1 year	05.22.2017
<input checked="" type="checkbox"/> LISN	Rohde & Schwarz	ENV216	100073	1 year	12.23.2016
<input type="checkbox"/> LISN	Rohde & Schwarz	ENV216	100073	1 year	07.18.2017
<input type="checkbox"/> Software	Rohde & Schwarz	EMC32 VER8.54.0	-	-	-
<u>Radiated Emission</u>					
-For measurement below 1 GHz					
<input checked="" type="checkbox"/> EMI Test Receiver	Rohde & Schwarz	ESU40	100524	1 year	08.16.2017
<input checked="" type="checkbox"/> Trilog Antenna	Schwarzbeck	VULB 9168	760	2 year	04.06.2017
<input checked="" type="checkbox"/> Antenna master	HD GmbH	MA240	240/520	N/A	-
<input checked="" type="checkbox"/> Antenna master controller	HD GmbH	HD 100	100/637	N/A	-
<input checked="" type="checkbox"/> Turn Table	INNCO Systems	1060-2M	-	N/A	-
<input checked="" type="checkbox"/> Turn Table controller	INNCO Systems	CO2000	-	N/A	-
<input type="checkbox"/> EMI Test Receiver	Rohde & Schwarz	ESU26	100241	1 year	08.16.2017
<input type="checkbox"/> Antenna master	INNCO Systems	MA4000-EP	MA4000/283	N/A	-
<input type="checkbox"/> Turn Table	INNCO Systems	DT3000-3T	DT3000/69	N/A	-
<input checked="" type="checkbox"/> Software	Rohde & Schwarz	EMC32 VER8.40.0	-	-	-
-For measurement above 1 GHz					
<input checked="" type="checkbox"/> EMI Test Receiver	Rohde & Schwarz	ESU40	100524	1 year	08.16.2017
<input checked="" type="checkbox"/> Antenna master	INNCO Systems	MA4000-XP-ET	48709515	N/A	-
<input checked="" type="checkbox"/> Antenna master controller	INNCO Systems	CO 3000	CO 3000/870/ 35990515/L	N/A	-
<input checked="" type="checkbox"/> Turn Table	INNCO Systems	1060-2M	-	N/A	-
<input checked="" type="checkbox"/> Turn Table controller	INNCO	CO2000	-	N/A	-
<input checked="" type="checkbox"/> Power Amplifier	CERNEX	CBLU5183530	24348	1 year	06.01.2017
<input checked="" type="checkbox"/> Power Amplifier	CERNEX	CBL18265035	21873	1 year	01.19.2017
<input checked="" type="checkbox"/> Power Amplifier	CERNEX	CBL26405040	19660	1 year	07.11.2017
<input checked="" type="checkbox"/> Horn Antenna	Schwarzbeck	BBHA 9120D	296	2 year	10.12.2016
<input checked="" type="checkbox"/> Horn Antenna	Schwarzbeck	BBHA 9170	BBHA9170124	2 year	04.25.2017
<input type="checkbox"/> Antenna master controller	HD GmbH	HD 100	100/637	N/A	-
<input type="checkbox"/> Power Amplifier	CERNEX	CBLU1183540	21691	1 year	06.28.2017
<input type="checkbox"/> Antenna master	HD GmbH	MA240	240/520	N/A	-
<input type="checkbox"/> Horn Antenna	Schwarzbeck	BBHA 9120D	1300	2 year	06.30.2017
<input type="checkbox"/> EMI Test Receiver	Rohde & Schwarz	ESU26	100241	1 year	08.16.2017
<input type="checkbox"/> Turn Table	INNCO Systems	DT3000-3T	DT3000/69	N/A	-
<input checked="" type="checkbox"/> Software	Rohde & Schwarz	EMC32 VER8.40.0	-	-	-



## 7. CONCLUSION

The data collected shows that the **EUT Type: Multi-band GSM/WCDMA/LTE Phone with WLAN, Bluetooth, Model: LM-X210MA, FCC ID: ZNFX210MA** complies with §15.107 and §15.109 of the FCC rules.



## 8. APPENDIX A. TEST SETUP PHOTOGRAPHS

Please refer to Appendix A