



# FCC RF Test Report

**APPLICANT** : LG Electronics Mobile Comm USA  
**EQUIPMENT** : Smart phone  
**BRAND NAME** : LG  
**MODEL NAME** : LG-X180g, X180g, LGX180g  
**FCC ID** : ZNFX180G  
**STANDARD** : FCC 47 CFR Part 2, 22(H), 24(E)  
**CLASSIFICATION** : PCS Licensed Transmitter Held to Ear (PCE)

The product was received on Aug. 19, 2015 and testing was completed on Oct. 21, 2015. We, SPORTON INTERNATIONAL (KUNSHAN) INC., would like to declare that the tested sample has been evaluated in accordance with the test procedures given in ANSI / TIA / EIA-603-D-2010 and has been in compliance with the applicable technical standards.

The test results in this report apply exclusively to the tested model / sample. Without written approval of SPORTON INTERNATIONAL (KUNSHAN) INC., the test report shall not be reproduced except in full.

Prepared by: James Huang / Manager

Approved by: Jones Tsai / Manager



**SPORTON INTERNATIONAL (KUNSHAN) INC.**  
**No. 3-2, PingXiang Road, Kunshan, Jiangsu Province, P. R. China**



# TABLE OF CONTENTS

**REVISION HISTORY.....3**

**SUMMARY OF TEST RESULT .....4**

**1 GENERAL DESCRIPTION .....5**

    1.1 Applicant.....5

    1.2 Manufacturer .....5

    1.3 Product Feature of Equipment Under Test .....5

    1.4 Product Specification subjective to this standard .....6

    1.5 Modification of EUT .....6

    1.6 Maximum ERP/EIRP Power, Frequency Tolerance, and Emission Designator .....7

    1.7 Testing Location .....7

    1.8 Applicable Standards .....7

**2 TEST CONFIGURATION OF EQUIPMENT UNDER TEST.....8**

    2.1 Test Mode.....8

    2.2 Connection Diagram of Test System ..... 10

    2.3 Support Unit used in test configuration ..... 11

    2.4 Measurement Results Explanation Example ..... 11

**3 TEST RESULT..... 12**

    3.1 Conducted Output Power Measurement..... 12

    3.2 Peak-to-Average Ratio ..... 14

    3.3 Effective Radiated Power and Effective Isotropic Radiated Power Measurement .....20

    3.4 99% Occupied Bandwidth and 26dB Bandwidth Measurement.....24

    3.5 Band Edge Measurement.....39

    3.6 Conducted Spurious Emission Measurement.....48

    3.7 Field Strength of Spurious Radiation Measurement .....61

    3.8 Frequency Stability Measurement.....67

**4 LIST OF MEASURING EQUIPMENT .....72**

**5 UNCERTAINTY OF EVALUATION .....73**



### REVISION HISTORY

REPORT NO.	VERSION	DESCRIPTION	ISSUED DATE
FG581902	Rev. 01	Initial issue of report	Nov. 13, 2015
FG581902	Rev. 02	1. Revised ANSI / TIA / EIA-603-C-2004 to ANSI / TIA / EIA-603-D-2010 2. Added L/H channel for conducted spurious emission.	Nov. 17, 2015



### SUMMARY OF TEST RESULT

Report Section	FCC Rule	Description	Limit	Result	Remark
3.1	§2.1046	Conducted Output Power	N/A	PASS	-
3.2	§24.232(d)	Peak-to-Average Ratio	<13 dB	PASS	-
3.3	§22.913(a)(2)	Effective Radiated Power	< 7 Watts	PASS	-
	§24.232(c)	Equivalent Isotropic Radiated Power	< 2 Watts	PASS	-
3.4	§2.1049	Occupied Bandwidth	N/A	PASS	-
3.5	§2.1051 §22.917(a) §24.238(a)	Band Edge Measurement	< 43+10log <sub>10</sub> (P[Watts])	PASS	-
3.6	§2.1051 §22.917(a) §24.238(a)	Conducted Spurious Emission	< 43+10log <sub>10</sub> (P[Watts])	PASS	-
3.7	§2.1053 §22.917(a) §24.238(a)	Field Strength of Spurious Radiation	< 43+10log <sub>10</sub> (P[Watts])	PASS	Under limit 29.52 dB at 7521.000 MHz
3.8	§2.1055 §22.355	Frequency Stability for Temperature & Voltage	< 2.5 ppm for Part 22 Within Authorized Band	PASS	-
	§2.1055 §24.235				



# 1 General Description

## 1.1 Applicant

**LG Electronics Mobile Comm USA**  
1000 Sylvan Avenue Englewood Cliffs, NJ 07632

## 1.2 Manufacturer

**Arima Communications Corp.**  
6F,No.866,Jhongjheng Rd., Jhonghe Dist., New Taipei City 23586, Taiwan

## 1.3 Product Feature of Equipment Under Test

Product Feature	
Equipment	Smart phone
Brand Name	LG
Model Name	LG-X180g, X180g, LGX180g
FCC ID	ZNFX180G
EUT supports Radios application	GSM/GPRS/EGPRS(Downlink Only)/ WCDMA/HSPA/HSPA+(Downlink Only) WLAN 2.4GHz 802.11b/g/n HT20/ HT40 Bluetooth v3.0 + EDR/Bluetooth v4.0 LE
IMEI Code	Conducted:354597070000044 Radiation:354597070011272/354597070011200
HW Version	5528MB-005
SW Version	V08a
EUT Stage	Production Unit

**Remark:** The above EUT's information was declared by manufacturer. Please refer to the specifications or user's manual for more detailed description.

### 1.4 Product Specification subjective to this standard

Product Specification subjective to this standard	
<b>Tx Frequency</b>	GSM850: 824.2 MHz ~ 848.8 MHz GSM1900: 1850.2 MHz ~ 1909.8MHz WCDMA Band V: 826.4 MHz ~ 846.6 MHz WCDMA Band II: 1852.4 MHz ~ 1907.6 MHz
<b>Rx Frequency</b>	GSM850: 869.2 MHz ~ 893.8 MHz GSM1900: 1930.2 MHz ~ 1989.8 MHz WCDMA Band V: 871.4 MHz ~ 891.6 MHz WCDMA Band II: 1932.4 MHz ~ 1987.6 MHz
<b>Maximum Output Power to Antenna</b>	GSM850 : 33.42 dBm GSM1900 : 30.48 dBm WCDMA Band V : 23.96 dBm WCDMA Band II : 23.18 dBm
<b>Antenna Type</b>	IFA Antenna
<b>Type of Modulation</b>	GSM: GMSK GPRS: GMSK EDGE: GMSK / 8PSK(Downlink Only) WCDMA: QPSK (Uplink) HSDPA: QPSK (Uplink) HSUPA: QPSK (Uplink) HSPA+: 16QAM (Downlink Only)

### 1.5 Modification of EUT

No modifications are made to the EUT during all test items.

### 1.6 Maximum ERP/EIRP Power, Frequency Tolerance, and Emission Designator

FCC Rule	System	Type of Modulation	Maximum ERP/EIRP (W)	Frequency Tolerance (ppm)	Emission Designator
Part 22	GSM850 GSM	GMSK	0.9268	0.0574	246KGXW
Part 22	WCDMA Band V RMC 12.2Kbps	QPSK	0.0914	0.0741	4M16F9W
Part 24	GSM1900 GSM	GMSK	0.7063	0.0255	246KGXW
Part 24	WCDMA Band II RMC 12.2Kbps	QPSK	0.2143	0.0255	4M16F9W

### 1.7 Testing Location

<b>Test Site</b>	SPORTON INTERNATIONAL (KUNSHAN) INC.		
<b>Test Site Location</b>	No. 3-2, PingXiang Road, Kunshan, Jiangsu Province, P. R. China TEL: +86-0512-5790-0158 FAX: +86-0512-5790-0958		
<b>Test Site No.</b>	<b>Sporton Site No.</b>		<b>FCC Registration No.</b>
	TH01-KS	03CH02-KS	418269

### 1.8 Applicable Standards

According to the specifications of the manufacturer, the EUT must comply with the requirements of the following standards:

- FCC 47 CFR Part 2, 22(H), 24(E)
- ANSI / TIA / EIA-603-D-2010
- FCC KDB 971168 D01 Power Meas. License Digital Systems v02r02

**Remark:**

1. All test items were verified and recorded according to the standards and without any deviation during the test.
2. This EUT has also been tested and complied with the requirements of FCC Part 15, Subpart B, recorded in a separate test report.



## 2 Test Configuration of Equipment Under Test

### 2.1 Test Mode

Antenna port conducted and radiated test items were performed according to KDB 971168 D01 Power Meas. License Digital Systems v02r02 with maximum output power.

Radiated measurements were performed with rotating EUT in different three orthogonal test planes to find the maximum emission.

Radiated emissions were investigated as following frequency range:

1. 30 MHz to 10th harmonic for GSM850 and WCDMA Band V.
2. 30 MHz to 10th harmonic for GSM1900 and WCDMA Band II.

All modes and data rates and positions were investigated.

Test modes are chosen to be reported as the worst case configuration below:

Test Modes		
Band	Radiated TCs	Conducted TCs
GSM 850	■ GSM Link	■ GSM Link
GSM 1900	■ GSM Link	■ GSM Link
WCDMA Band V	■ RMC 12.2Kbps Link	■ RMC 12.2Kbps Link
WCDMA Band II	■ RMC 12.2Kbps Link	■ RMC 12.2Kbps Link





Conducted Power Measurement Results:

Conducted Power (*Unit: dBm)						
Band	GSM850			GSM1900		
Channel	128	189	251	512	661	810
Frequency	824.2	836.4	848.8	1850.2	1880.0	1909.8
GSM	33.42	33.31	33.25	30.48	30.44	30.43
GPRS class 8	33.37	33.28	33.20	30.47	30.45	30.40
GPRS class 10	31.66	31.65	31.63	28.71	28.74	28.91
GPRS class 11	28.43	28.47	28.48	25.45	25.52	25.81
GPRS class 12	26.87	26.91	26.92	23.91	24.00	24.23

Conducted Power (*Unit: dBm)						
Band	WCDMA Band V			WCDMA Band II		
Channel	4132	4182	4233	9262	9400	9538
Frequency	826.4	836.4	846.6	1852.4	1880.0	1907.6
AMR 12.2Kbps	23.91	23.95	23.90	23.07	23.10	23.16
RMC 12.2Kbps	23.92	23.96	23.90	23.08	23.11	23.18
HSDPA Subtest-1	22.94	22.98	22.83	22.11	22.14	22.17
HSDPA Subtest-2	22.93	22.95	22.79	22.10	22.11	22.15
HSDPA Subtest-3	22.36	22.35	22.33	21.63	21.52	21.81
HSDPA Subtest-4	22.33	22.37	22.31	21.61	21.50	21.79
HSUPA Subtest-1	20.68	20.77	20.75	19.89	19.99	20.12
HSUPA Subtest-2	20.24	20.35	20.51	19.88	19.97	20.10
HSUPA Subtest-3	21.71	21.76	21.82	20.87	20.94	21.16
HSUPA Subtest-4	20.21	20.33	20.45	19.39	19.48	19.98
HSUPA Subtest-5	21.77	21.85	21.94	21.18	21.29	21.38

## 2.2 Connection Diagram of Test System

Part 22H

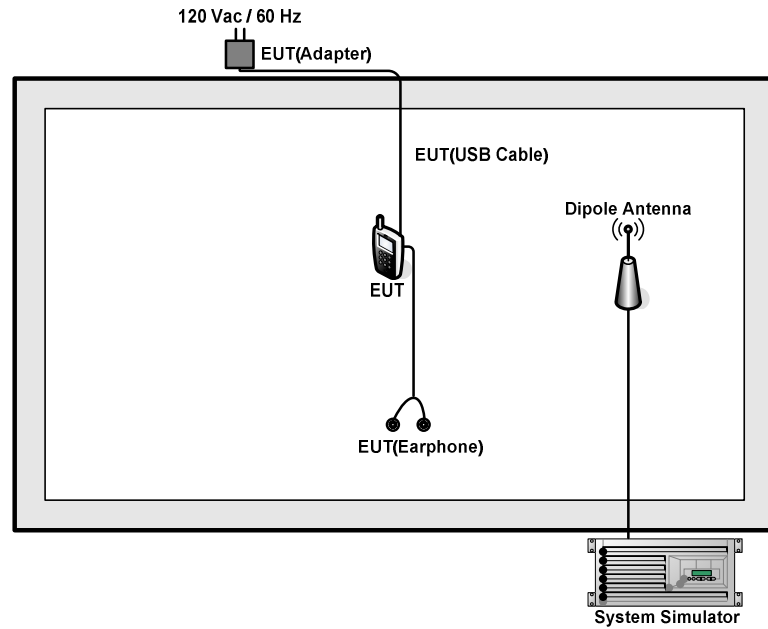

Part 24E

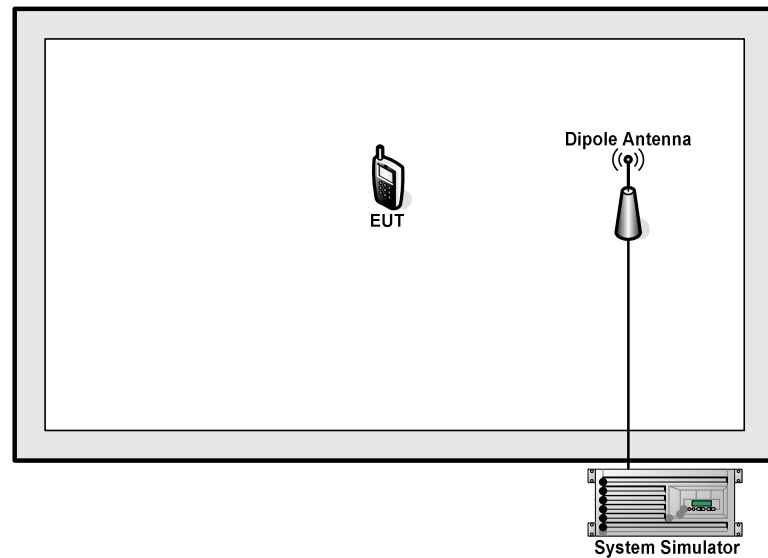



### 2.3 Support Unit used in test configuration

Item	Equipment	Trade Name	Model No.	FCC ID	Data Cable	Power Cord
1.	System Simulator	R&S	CMU 200	N/A	N/A	Unshielded, 1.8 m
2.	DC Power Supply	GW INSTEK	GPS-3030D	N/A	N/A	Unshielded, 1.8 m

### 2.4 Measurement Results Explanation Example

For all conducted test items:

The offset level is set in the spectrum analyzer to compensate the RF cable loss and attenuator factor between RF conducted output port and spectrum analyzer. With the offset compensation, the spectrum analyzer reading level will be exactly the RF output level.

The spectrum analyzer offset is derived from RF cable loss and attenuator factor.

*Offset = RF cable loss + attenuator factor.*

The following shows an offset computation example with RF cable loss 4.5 dB and a 10dB attenuator.

Example :

$$\begin{aligned} \text{Offset(dB)} &= \text{RF cable loss(dB)} + \text{attenuator factor(dB)}. \\ &= 4.5 + 10 = 14.5 \text{ (dB)} \end{aligned}$$

### **3 Test Result**

#### **3.1 Conducted Output Power Measurement**

##### **3.1.1 Description of the Conducted Output Power Measurement**

A system simulator was used to establish communication with the EUT. Its parameters were set to enforce EUT transmitting at the maximum power. The measured power in the radio frequency on the transmitter output terminals shall be reported.

##### **3.1.2 Measuring Instruments**

The measuring equipment is listed in the section 4 of this test report.

##### **3.1.3 Test Procedures**

1. The transmitter output port was connected to the system simulator.
2. Set EUT at maximum power through system simulator.
3. Select lowest, middle, and highest channels for each band and different modulation.
4. Measure the maximum burst average power for GSM and maximum average power for other modulation signal.

##### **3.1.4 Test Setup**

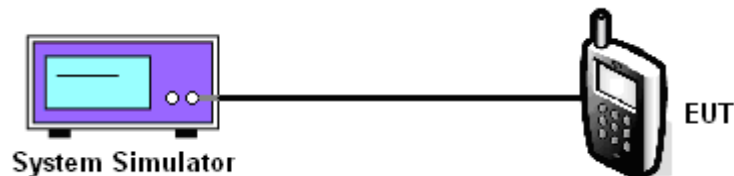

### 3.1.5 Test Result of Conducted Output Power

Cellular Band						
Modes	GSM850 (GSM)			WCDMA Band V (RMC 12.2Kbps)		
Channel	128 (Low)	189 (Mid)	251 (High)	4132 (Low)	4182 (Mid)	4233 (High)
Frequency (MHz)	824.2	836.4	848.8	826.4	836.4	846.6
Conducted Power (dBm)	33.42	33.31	33.25	23.92	23.96	23.90

PCS Band						
Modes	GSM1900 (GSM)			WCDMA Band II (RMC 12.2Kbps)		
Channel	512 (Low)	661 (Mid)	810 (High)	9262 (Low)	9400 (Mid)	9538 (High)
Frequency (MHz)	1850.2	1880	1909.8	1852.4	1880	1907.6
Conducted Power (dBm)	30.48	30.44	30.43	23.08	23.11	23.18

**Note:** maximum burst average power for GSM, and maximum average power for WCDMA.

## 3.2 Peak-to-Average Ratio

### 3.2.1 Description of the PAR Measurement

The peak-to-average ratio (PAR) of the transmission may not exceed 13 dB.

### 3.2.2 Measuring Instruments

The measuring equipment is listed in the section 4 of this test report.

### 3.2.3 Test Procedures

1. The testing follows FCC KDB 971168 v02r02 Section 5.7.1.
2. The EUT was connected to the spectrum analyzer and system simulator via a power divider.
3. For GSM/EGPRS operating modes:
  - a. Set EUT in maximum power output.
  - b. Set the RBW = 1MHz, VBW = 3MHz, Peak detector on spectrum analyzer for first trace.
  - c. Set the RBW = 1MHz, VBW = 3MHz, RMS detector on spectrum analyzer for second trace.
  - d. The wanted burst signal is triggered by spectrum analyzer, and measured respectively the peak level and Mean level without burst-off time, after system simulator has synchronized with the spectrum analyzer.
4. For UMTS operating modes:
  - a. Set the CCDF (Complementary Cumulative Distribution Function) option on the spectrum analyzer.
  - b. The highest RF powers were measured and recorded the maximum PAPR level associated with a probability of 0.1 %.
5. Record the deviation as Peak to Average Ratio.

### 3.2.4 Test Setup

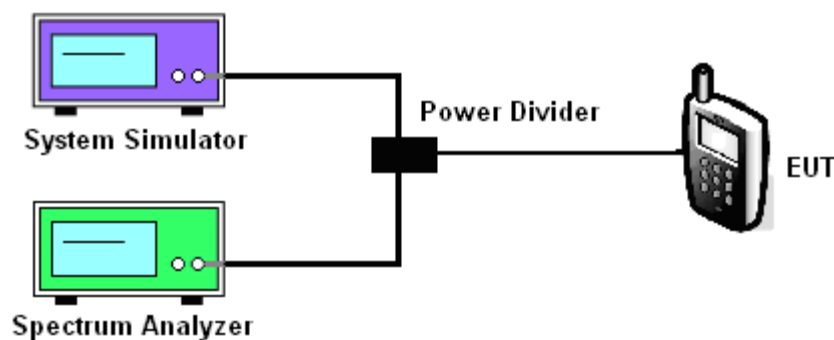



### 3.2.5 Test Result of Peak-to-Average Ratio

PCS Band						
Modes	GSM1900 (GSM)			WCDMA Band II (RMC 12.2Kbps)		
Channel	512 (Low)	661 (Mid)	810 (High)	9262 (Low)	9400 (Mid)	9538 (High)
Frequency (MHz)	1850.2	1880	1909.8	1852.4	1880	1907.6
Peak-to-Average Ratio (dB)	0.26	0.26	0.27	3.04	3.00	2.88



### 3.2.6 Test Result (Plots) of Peak-to-Average Ratio

<b>Band :</b>	GSM 1900	<b>Test Mode :</b>	GSM Link (GMSK)
---------------	----------	--------------------	-----------------

Peak-to-Average Ratio on Channel 512 (1850.2 MHz)

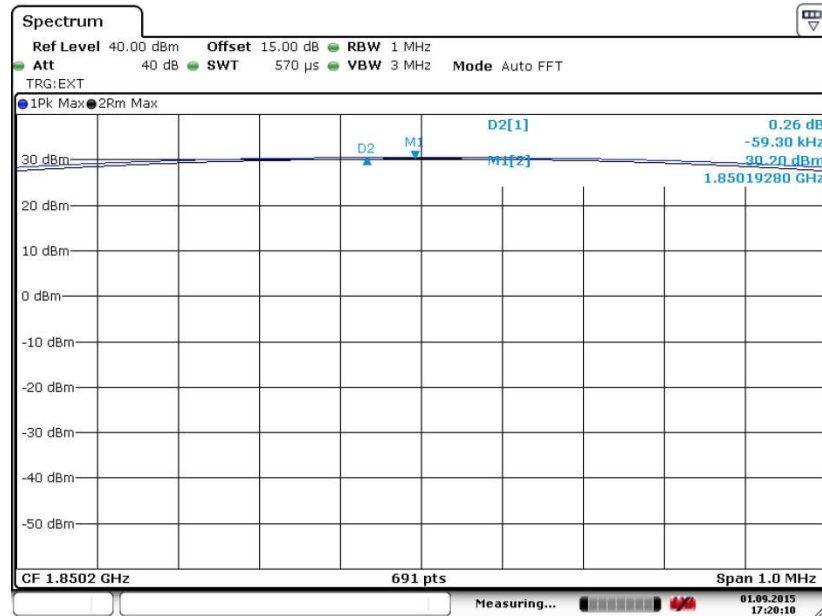

Date: 1.SEP.2015 17:20:10

Peak-to-Average Ratio on Channel 661 (1880.0 MHz)

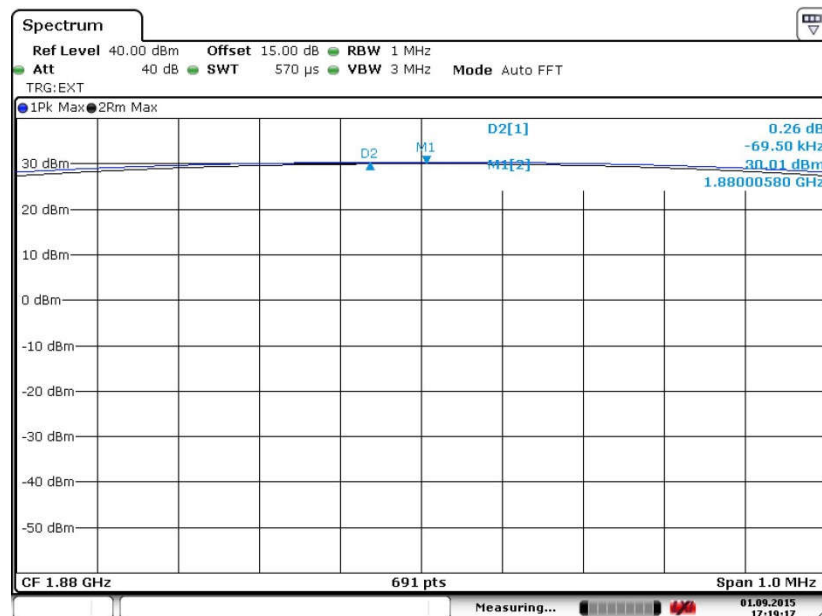

Date: 1.SEP.2015 17:19:17





Peak-to-Average Ratio on Channel 810 (1909.8 MHz)

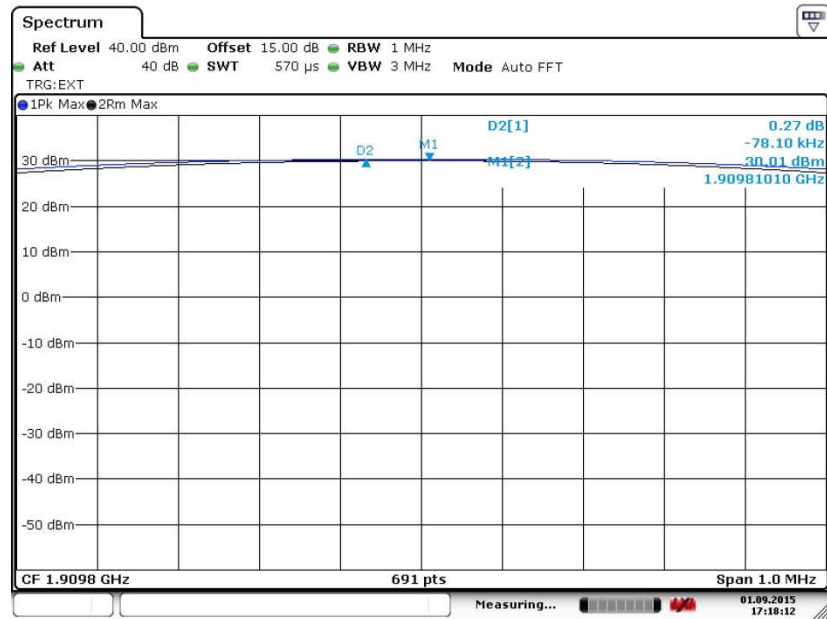

Date: 1.SEP.2015 17:18:12



<b>Band :</b>	WCDMA Band II	<b>Test Mode :</b>	RMC 12.2Kbps Link (QPSK)
---------------	---------------	--------------------	--------------------------

**Peak-to-Average Ratio on Channel 9262 (1852.4 MHz)**

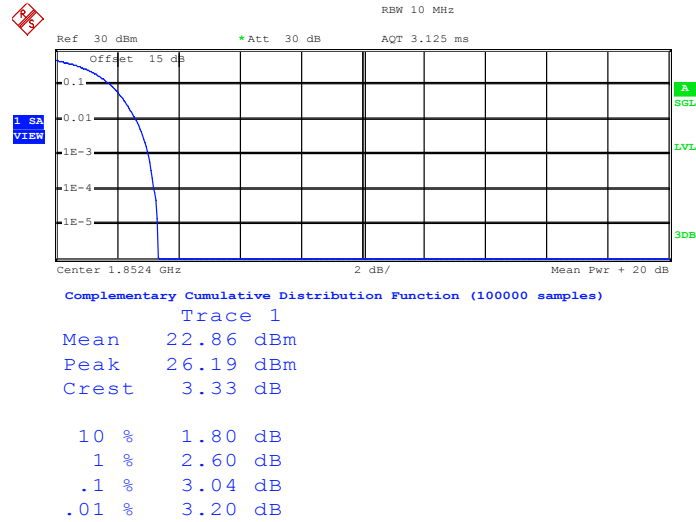

Date: 1.SEP.2015 03:58:27

**Peak-to-Average Ratio on Channel 9400 (1880.0 MHz)**

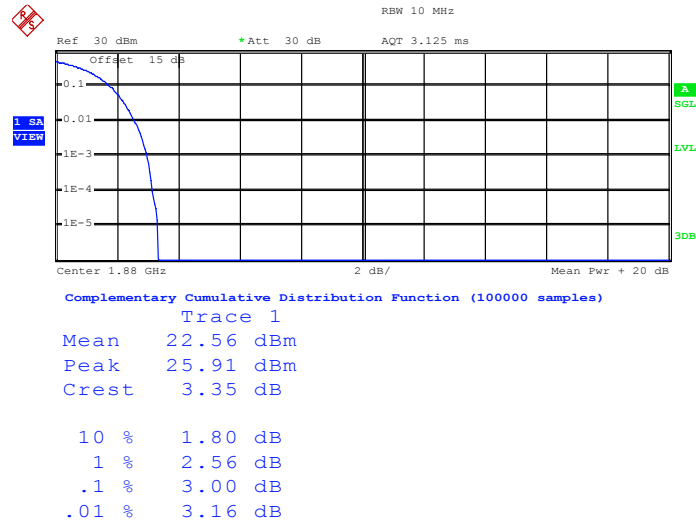

Date: 1.SEP.2015 03:57:35



Peak-to-Average Ratio on Channel 9538 (1907.6 MHz)

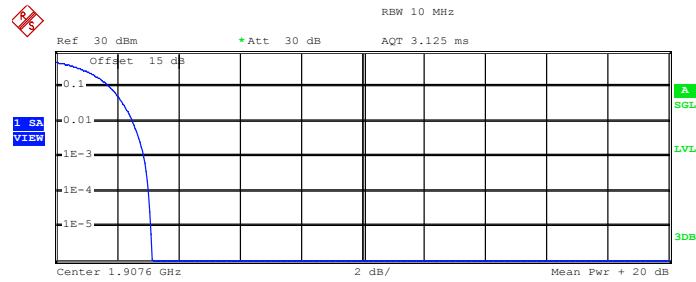

Complementary Cumulative Distribution Function (100000 samples)

Trace 1

Mean	22.54 dBm
Peak	25.70 dBm
Crest	3.16 dB
10 %	1.76 dB
1 %	2.52 dB
.1 %	2.88 dB
.01 %	3.04 dB

Date: 1.SEP.2015 03:56:51



### 3.3 Effective Radiated Power and Effective Isotropic Radiated Power Measurement

#### 3.3.1 Description of the ERP/EIRP Measurement

The substitution method, in ANSI / TIA / EIA-603-D-2010, was used for ERP/EIRP measurement, and the spectrum analyzer configuration follows KDB 971168 D01 Power Meas. License Digital Systems v02r02. The ERP of mobile transmitters must not exceed 7 Watts and the EIRP of mobile transmitters are limited to 2 Watts.

#### 3.3.2 Measuring Instruments

The measuring equipment is listed in the section 4 of this test report.

#### 3.3.3 Test Procedures

1. The testing follows FCC KDB 971168 v02r02 Section 5.2.1. (for CDMA/WCDMA), Section 5.2.2.2 (for GSM/GPRS/EDGE) and ANSI / TIA-603-D-2010 Section 2.2.17.
2. The EUT was placed on a non-conductive rotating platform 0.8 meters high in a semi-anechoic chamber. The radiated emission at the fundamental frequency was measured at 3 m with a test antenna and a spectrum analyzer with RMS detector per section 5. of KDB 971168 D01.
3. During the measurement, the system simulator parameters were set to force the EUT transmitting at maximum output power. The maximum emission was recorded from analyzer power level (LVL) from the 360 degrees rotation of the turntable and the test antenna raised and lowered over a range from 1 to 4 meters in both horizontally and vertically polarized orientations.
4. Effective Isotropic Radiated Power (EIRP) was measured by substitution method according to TIA/EIA-603-D. The EUT was replaced by the substitution antenna at same location, and then a known power from S.G. was applied into the dipole antenna through a Tx cable, and then recorded the maximum Analyzer reading through raised and lowered the test antenna. The correction factor (in dB) = S.G. - Tx Cable loss + Substitution antenna gain - Analyzer reading. Then the EUT's EIRP was calculated with the correction factor,  $EIRP = LVL + \text{Correction factor}$  and  $ERP = EIRP - 2.15$ . Take the record of the output power at substitution antenna.



	GSM/GPRS/EDGE	WCDMA/HSPA
SPAN	500kHz	10MHz
RBW	10kHz	100kHz
VBW	30kHz	300kHz
Detector	RMS	RMS
Trace	Average	Average
Average Type	Power	Power
Sweep Count	100	100



3.3.4 Test Result of ERP

GSM850 (GSM) Radiated Power ERP					
Channel	Frequency (MHz)	Horizontal		Vertical	
		ERP(dBm)	ERP(W)	ERP(dBm)	ERP(W)
Lowest	824.20	29.67	0.9268	16.03	0.0401
Middle	836.40	29.48	0.8872	16.32	0.0429
Highest	848.80	29.44	0.8790	16.80	0.0479
Limit	ERP < 7W	Result		PASS	

WCDMA Band V (RMC 12.2Kbps) Radiated Power ERP					
Channel	Frequency (MHz)	Horizontal		Vertical	
		ERP(dBm)	ERP(W)	ERP(dBm)	ERP(W)
Lowest	826.40	18.61	0.0726	7.60	0.0058
Middle	836.40	18.17	0.0656	7.97	0.0063
Highest	846.60	19.61	0.0914	9.81	0.0096
Limit	ERP < 7W	Result		PASS	



3.3.5 Test Result of EIRP

GSM1900 (GSM) Radiated Power EIRP					
Channel	Frequency (MHz)	Horizontal		Vertical	
		EIRP(dBm)	EIRP(W)	EIRP(dBm)	EIRP(W)
Lowest	1850.20	27.39	0.5483	27.20	0.5248
Middle	1880.00	27.74	0.5943	27.49	0.5610
Highest	1909.80	28.49	0.7063	28.47	0.7031
Limit	EIRP < 2W	Result		PASS	

WCDMA Band II (RMC 12.2Kbps) Radiated Power EIRP					
Channel	Frequency (MHz)	Horizontal		Vertical	
		EIRP(dBm)	EIRP(W)	EIRP(dBm)	EIRP(W)
Lowest	1852.40	21.32	0.1355	21.71	0.1483
Middle	1880.00	22.56	0.1803	23.14	0.2061
Highest	1907.60	22.65	0.1841	23.31	0.2143
Limit	EIRP < 2W	Result		PASS	



### 3.4 99% Occupied Bandwidth and 26dB Bandwidth Measurement

#### 3.4.1 Description of 99% Occupied Bandwidth and 26dB Bandwidth Measurement

The 99% occupied bandwidth is the width of a frequency band such that, below the lower and above the upper frequency limits, the mean powers emitted are each equal to a specified percentage 0.5% of the total mean transmitted power.

The emission bandwidth is defined as the width of the signal between two points, located at the 2 sides of the carrier frequency, outside of which all emissions are attenuated at least 26 dB below the transmitter power.

#### 3.4.2 Measuring Instruments

The measuring equipment is listed in the section 4 of this test report.

#### 3.4.3 Test Procedures

1. The testing follows FCC KDB 971168 v02r02 Section 4.2.
2. The EUT was connected to spectrum analyzer and system simulator via a power divider.
3. The spectrum analyzer center frequency is set to the nominal EUT channel center frequency. The span range for the spectrum analyzer shall be between two and five times the anticipated OBW.
4. The nominal resolution bandwidth (RBW) shall be in the range of 1 to 5 % of the anticipated OBW, and the VBW shall be at least 3 times the RBW.
5. Set the detection mode to peak, and the trace mode to max hold.
6. Determine the reference value: Set the EUT to transmit a modulated signal. Allow the trace to stabilize. Set the spectrum analyzer marker to the highest level of the displayed trace.  
(this is the reference value)
7. Determine the “-26 dB down amplitude” as equal to (Reference Value – X).
8. Place two markers, one at the lowest and the other at the highest frequency of the envelope of the spectral display such that each marker is at or slightly below the “-X dB down amplitude” determined in step 6. If a marker is below this “-X dB down amplitude” value it shall be placed as close as possible to this value. The OBW is the positive frequency difference between the two markers.

Use the 99 % power bandwidth function of the spectrum analyzer and report the measured bandwidth.



### 3.4.4 Test Setup

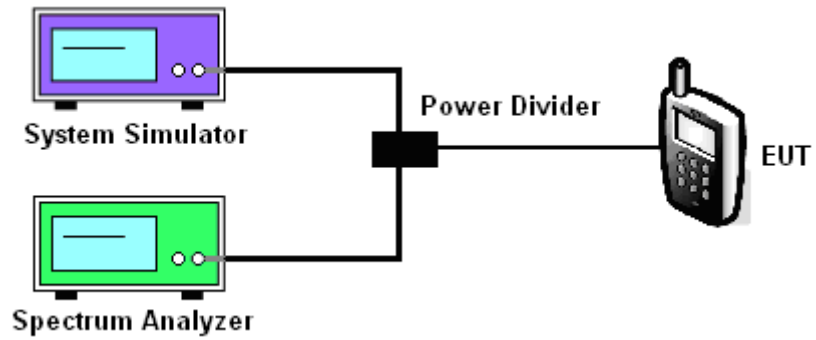



3.4.5 Test Result of Occupied Bandwidth and 26dB Bandwidth

Cellular Band			
Modes	GSM850 (GSM)		
Channel	128 (Low)	189 (Mid)	251 (High)
Frequency (MHz)	824.2	836.4	848.8
99% OBW (kHz)	246.00	244.00	244.00
26dB BW (kHz)	316.00	310.00	314.00

PCS Band			
Modes	GSM1900 (GSM)		
Channel	512 (Low)	661 (Mid)	810 (High)
Frequency (MHz)	1850.2	1880	1909.8
99% OBW (kHz)	244.00	244.00	246.00
26dB BW (kHz)	316.00	314.00	312.00

Cellular Band			
Modes	WCDMA Band V (RMC 12.2Kbps)		
Channel	4132 (Low)	4182 (Mid)	4233 (High)
Frequency (MHz)	826.4	836.4	846.6
99% OBW (MHz)	4.16	4.16	4.16
26dB BW (MHz)	4.72	4.72	4.70

PCS Band			
Modes	WCDMA Band II (RMC 12.2Kbps)		
Channel	9262 (Low)	9400 (Mid)	9538 (High)
Frequency (MHz)	1852.4	1880	1907.6
99% OBW (MHz)	4.16	4.16	4.16
26dB BW (MHz)	4.70	4.70	4.70



### 3.4.6 Test Result (Plots) of Occupied Bandwidth and 26dB Bandwidth

Band :	GSM 850	Test Mode :	GSM Link (GMSK)
--------	---------	-------------	-----------------

#### 99% Occupied Bandwidth Plot on Channel 128 (824.2 MHz)

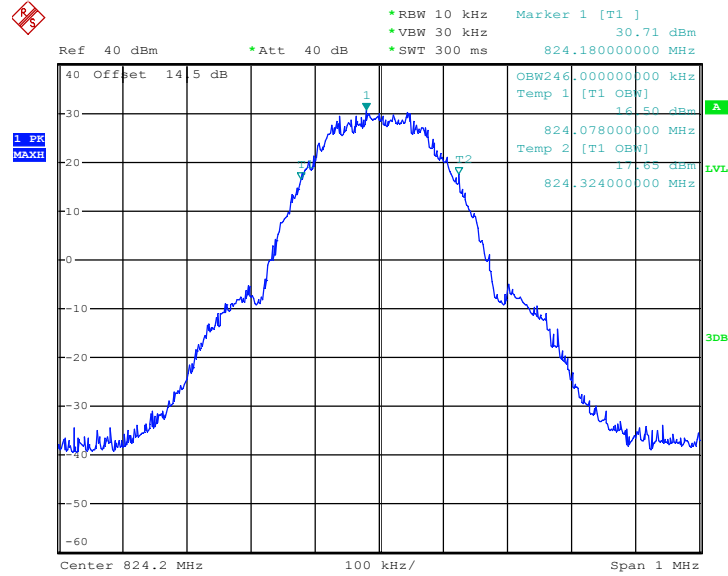

Date: 1.SEP.2015 02:44:13

#### 26dB Bandwidth Plot on Channel 128 (824.2 MHz)

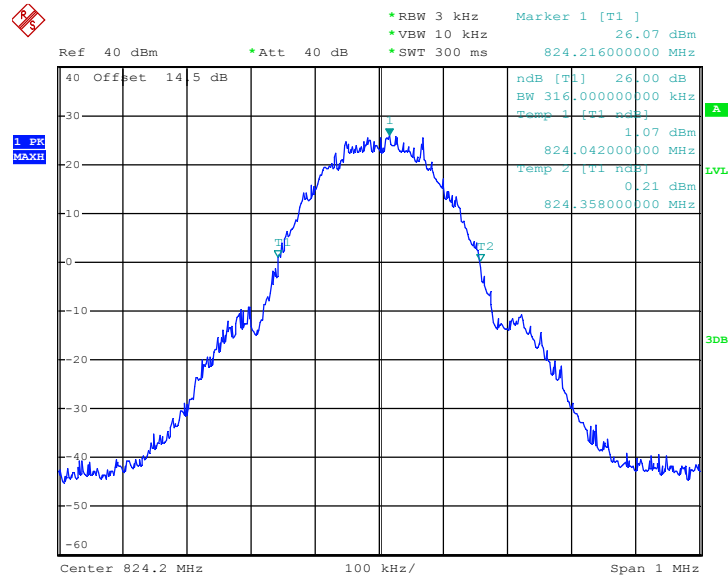

Date: 1.SEP.2015 02:28:27



99% Occupied Bandwidth Plot on Channel 189 (836.4 MHz)

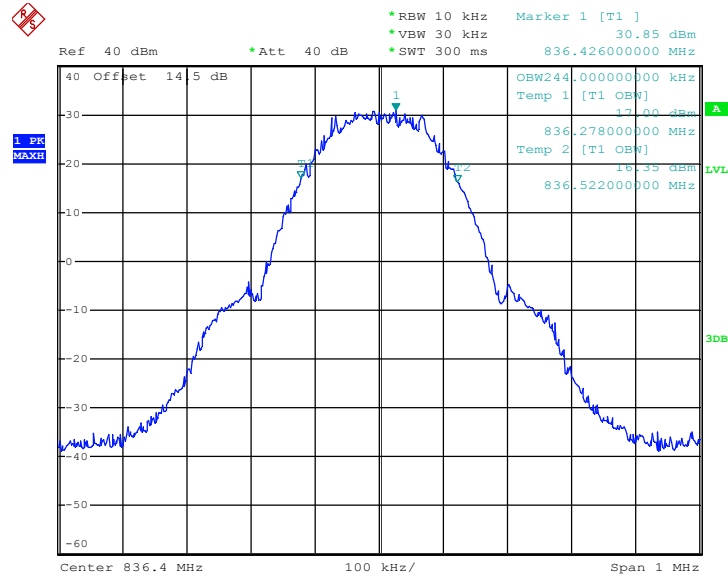

Date: 1.SEP.2015 02:43:14

26dB Bandwidth Plot on Channel 189 (836.4 MHz)

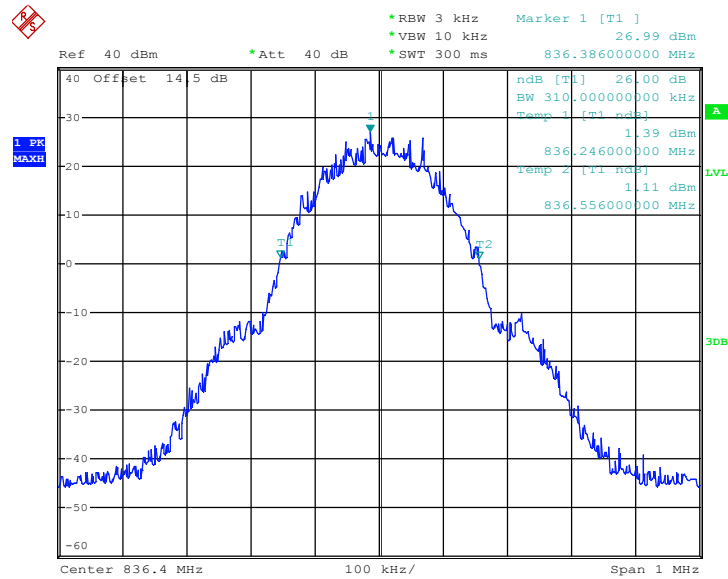

Date: 1.SEP.2015 02:29:37



99% Occupied Bandwidth Plot on Channel 251 (848.8 MHz)

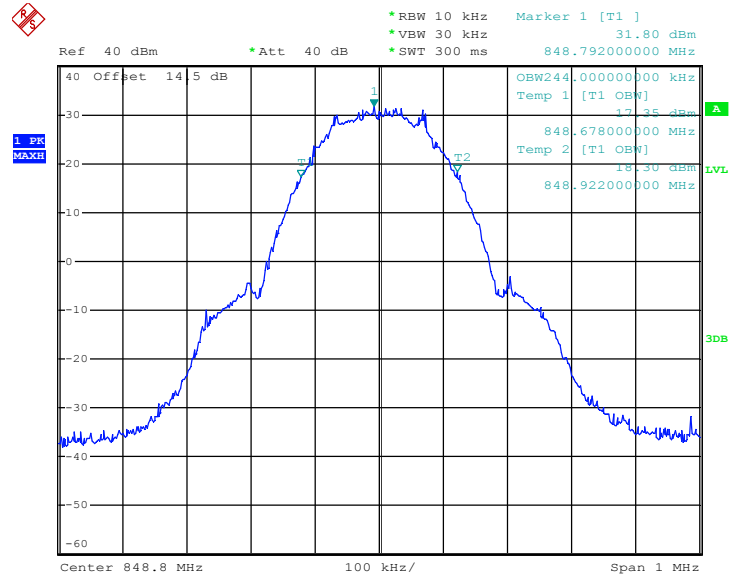

Date: 1.SEP.2015 02:34:42

26dB Bandwidth Plot on Channel 251 (848.8 MHz)

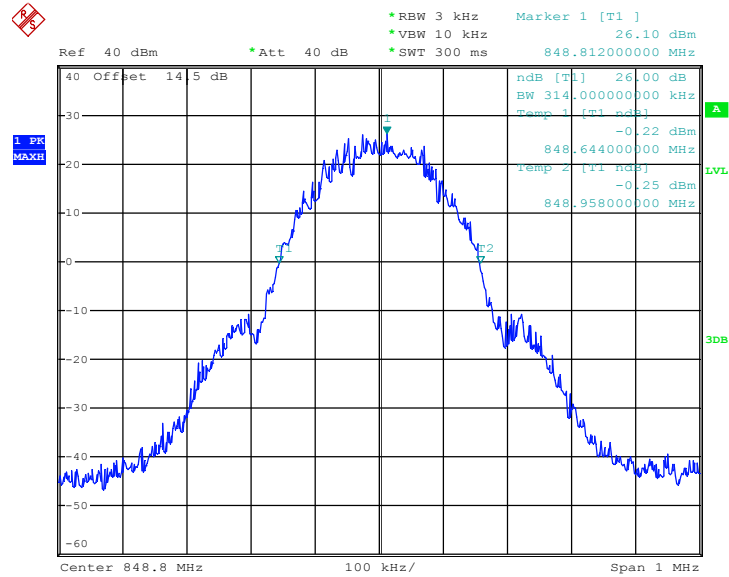

Date: 1.SEP.2015 02:30:22



Band :	GSM 1900	Test Mode :	GSM Link (GMSK)
--------	----------	-------------	-----------------

99% Occupied Bandwidth Plot on Channel 512 (1850.2 MHz)

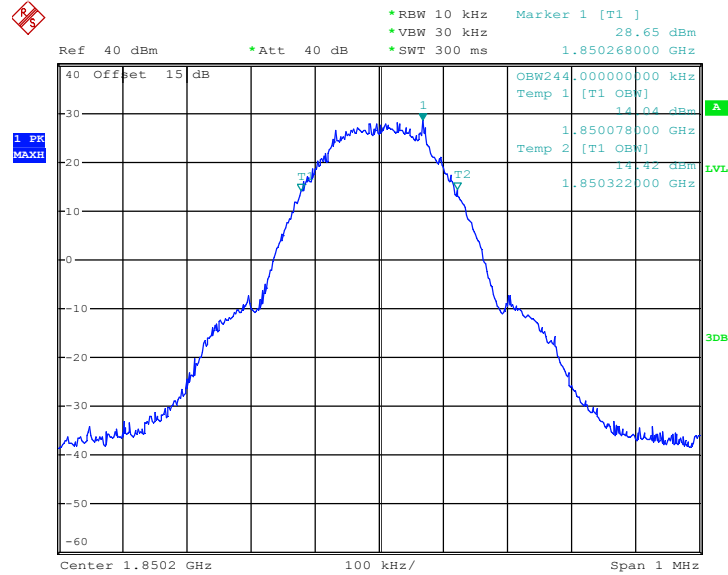

Date: 1.SEP.2015 04:20:02

26dB Bandwidth Plot on Channel 512 (1850.2 MHz)

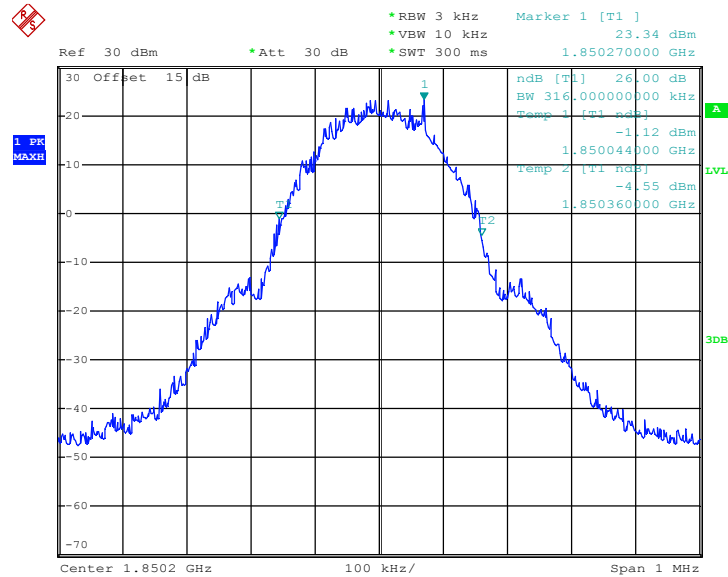

Date: 1.SEP.2015 04:09:35



99% Occupied Bandwidth Plot on Channel 661 (1880.0 MHz)

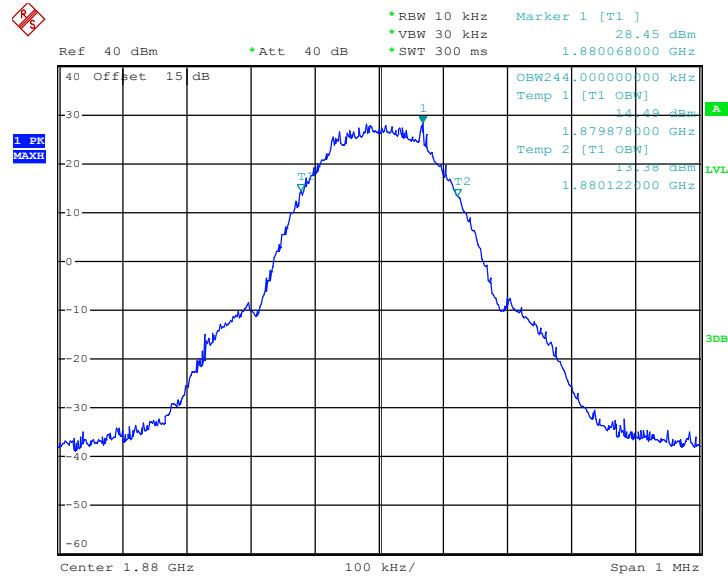

Date: 1.SEP.2015 04:18:34

26dB Bandwidth Plot on Channel 661 (1880.0 MHz)

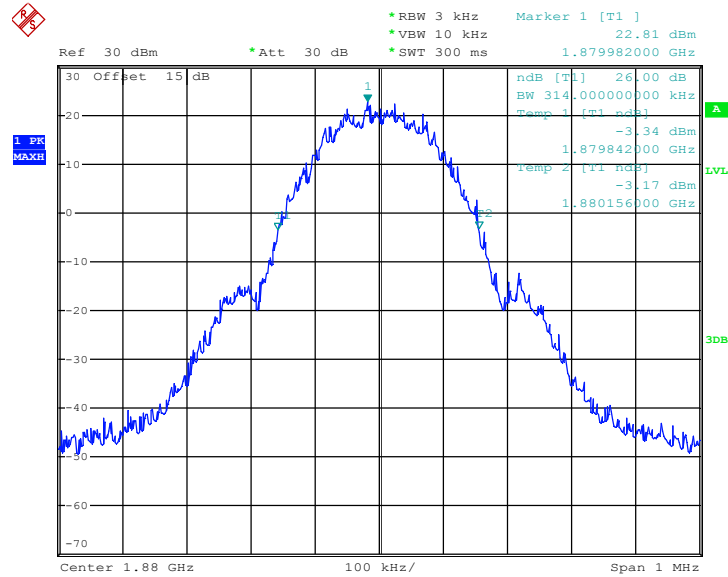

Date: 1.SEP.2015 04:10:22



99% Occupied Bandwidth Plot on Channel 810 (1909.8 MHz)

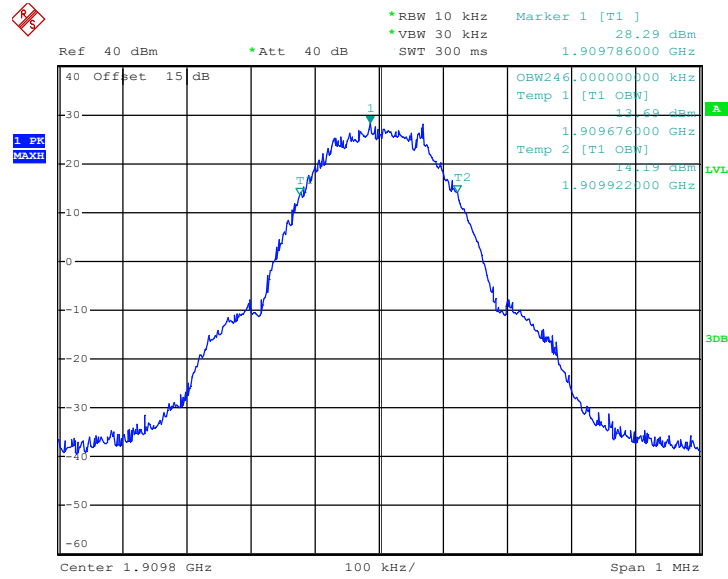

Date: 1.SEP.2015 04:14:01

26dB Bandwidth Plot on Channel 810 (1909.8 MHz)

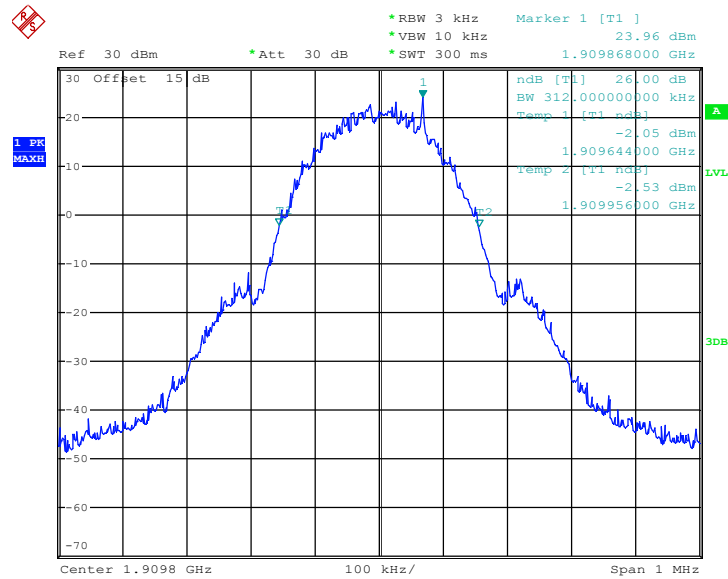

Date: 1.SEP.2015 04:11:43





Band :	WCDMA Band V	Test Mode :	RMC 12.2Kbps Link (QPSK)
--------	--------------	-------------	--------------------------

99% Occupied Bandwidth Plot on Channel 4132 (826.4 MHz)

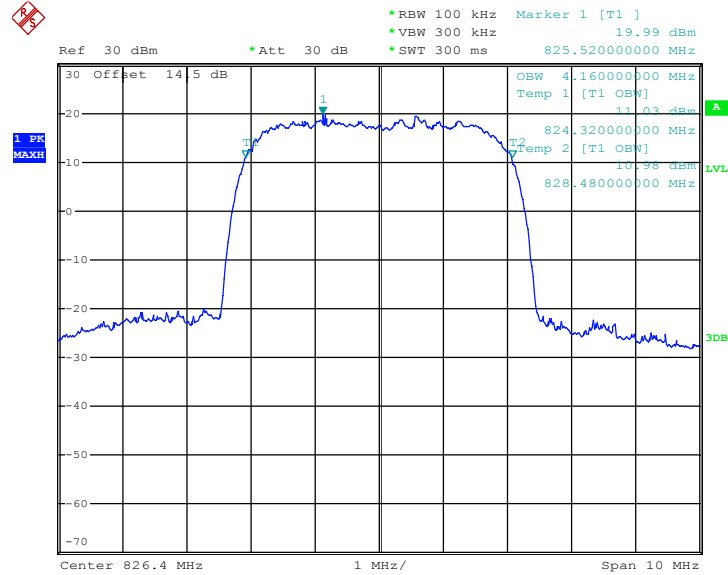

Date: 1.SEP.2015 03:38:15

26dB Bandwidth Plot on Channel 4132 (826.4 MHz)

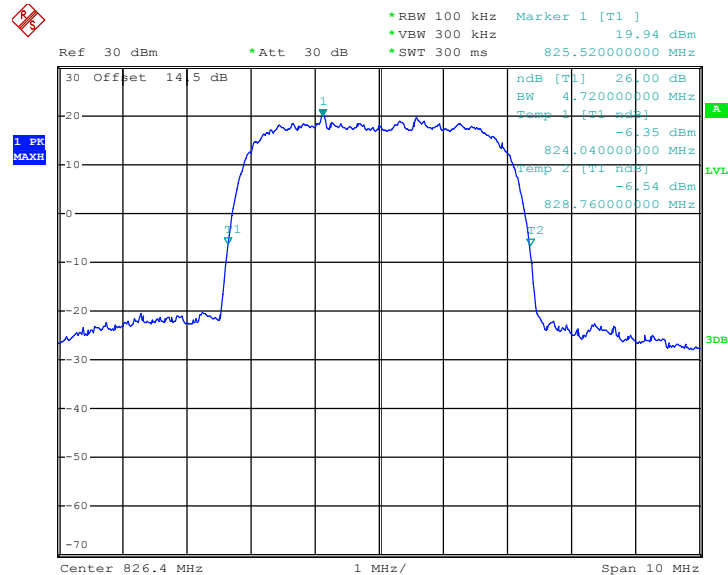

Date: 1.SEP.2015 03:32:28



99% Occupied Bandwidth Plot on Channel 4182 (836.4 MHz)

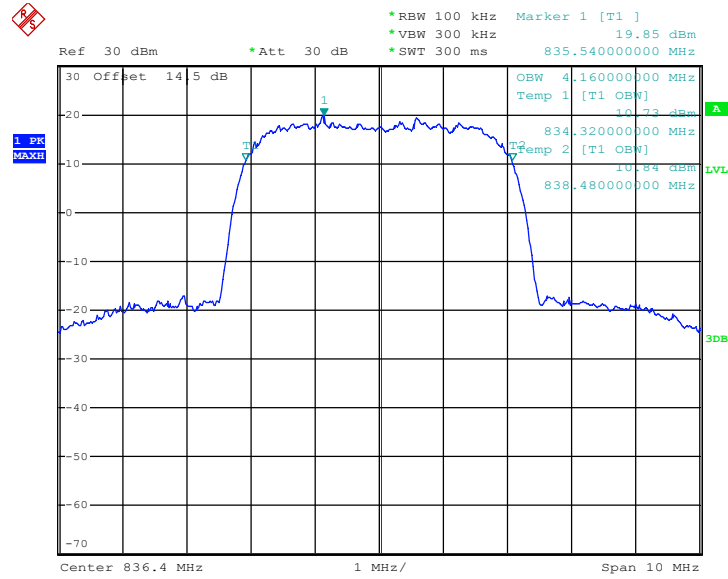

Date: 1.SEP.2015 03:37:32

26dB Bandwidth Plot on Channel 4182 (836.4 MHz)

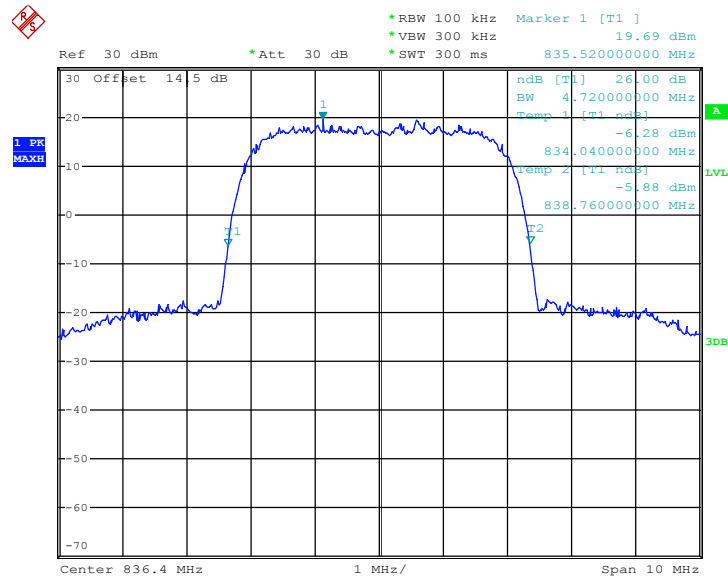

Date: 1.SEP.2015 03:32:52



99% Occupied Bandwidth Plot on Channel 4233 (846.6 MHz)

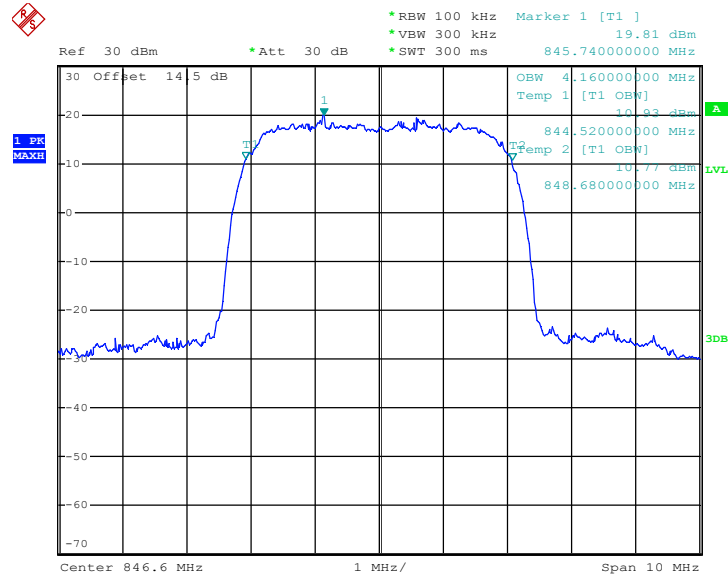

Date: 1.SEP.2015 03:34:10

26dB Bandwidth Plot on Channel 4233 (846.6 MHz)

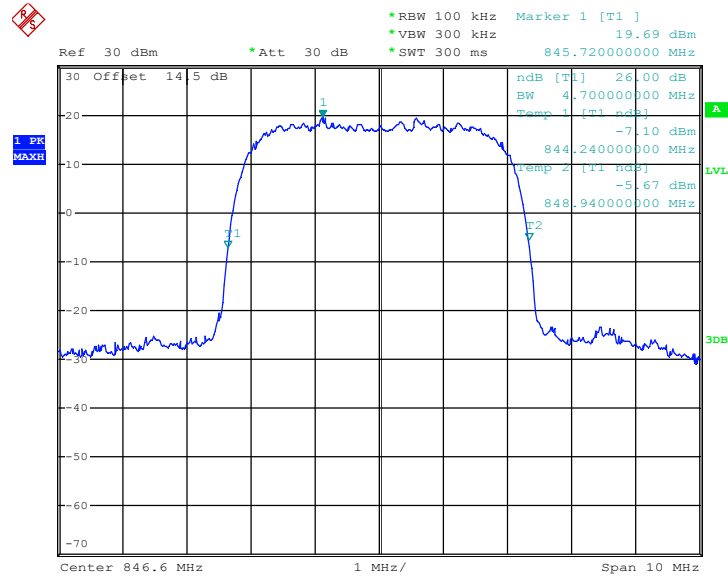

Date: 1.SEP.2015 03:33:30



<b>Band :</b>	WCDMA Band II	<b>Test Mode :</b>	RMC 12.2Kbps Link (QPSK)
---------------	---------------	--------------------	--------------------------

99% Occupied Bandwidth Plot on Channel 9262 (1852.4 MHz)

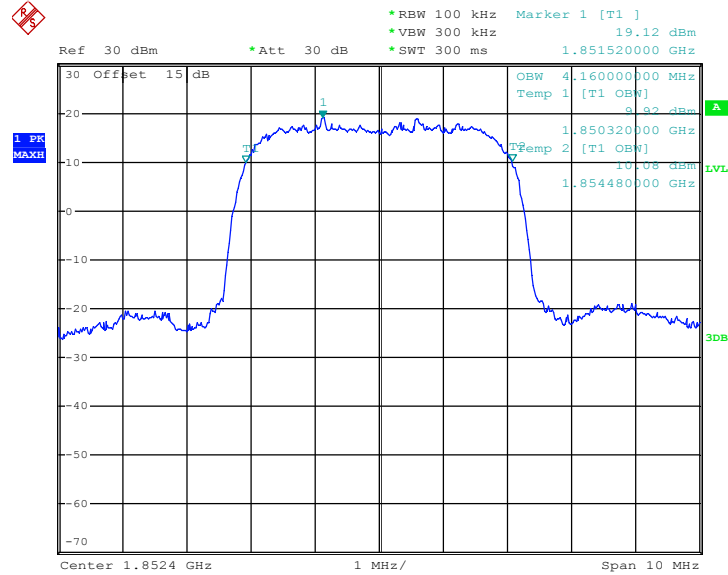

Date: 1.SEP.2015 04:04:23

26dB Bandwidth Plot on Channel 9262 (1852.4 MHz)

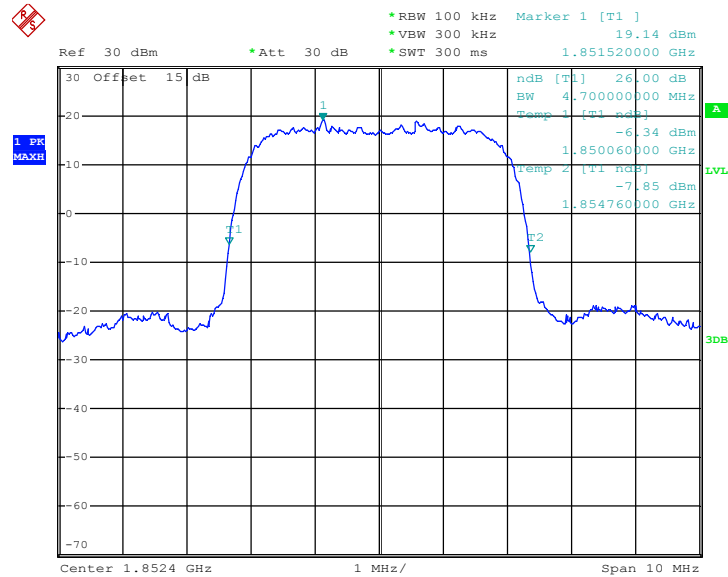

Date: 1.SEP.2015 04:00:16



99% Occupied Bandwidth Plot on Channel 9400 (1880.0 MHz)

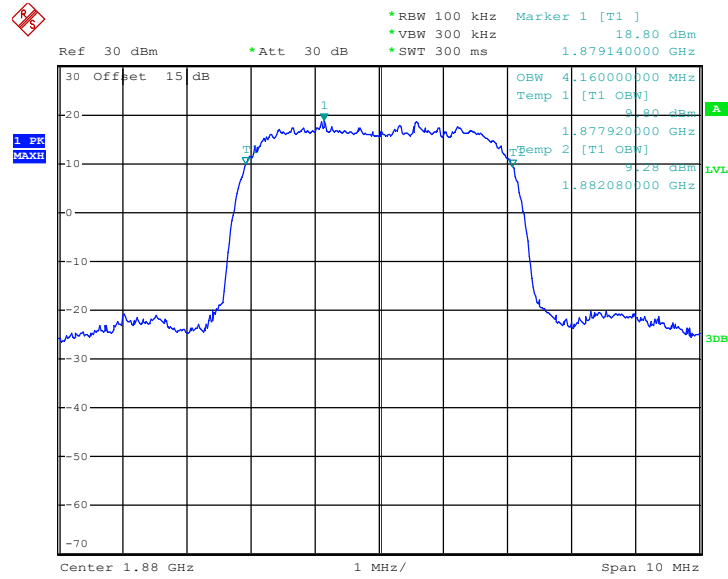

Date: 1.SEP.2015 04:03:46

26dB Bandwidth Plot on Channel 9400 (1880.0 MHz)

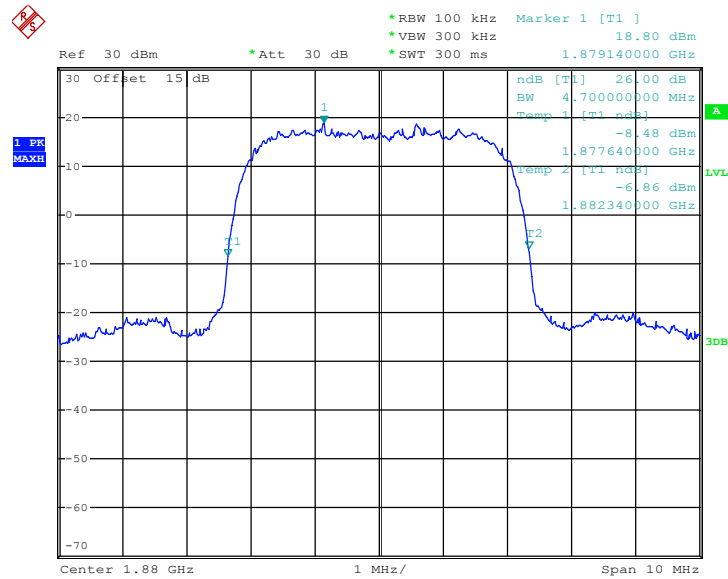

Date: 1.SEP.2015 04:00:51



99% Occupied Bandwidth Plot on Channel 9538 (1907.6 MHz)

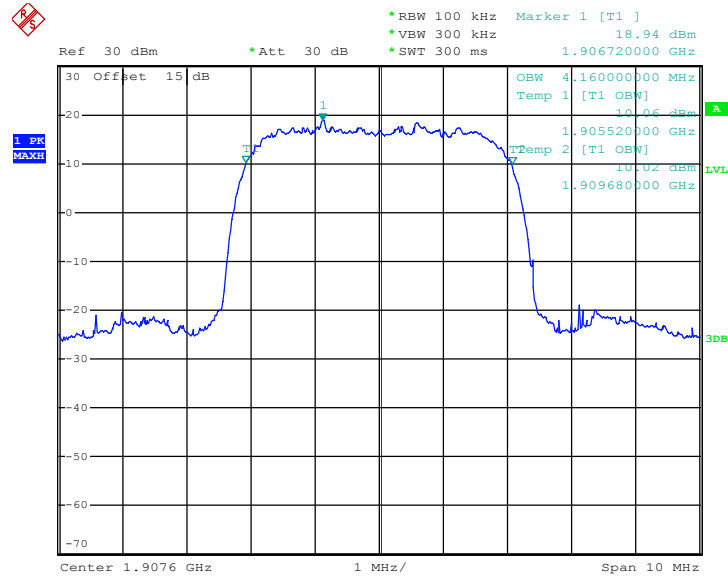

Date: 1.SEP.2015 04:02:07

26dB Bandwidth Plot on Channel 9538 (1907.6 MHz)

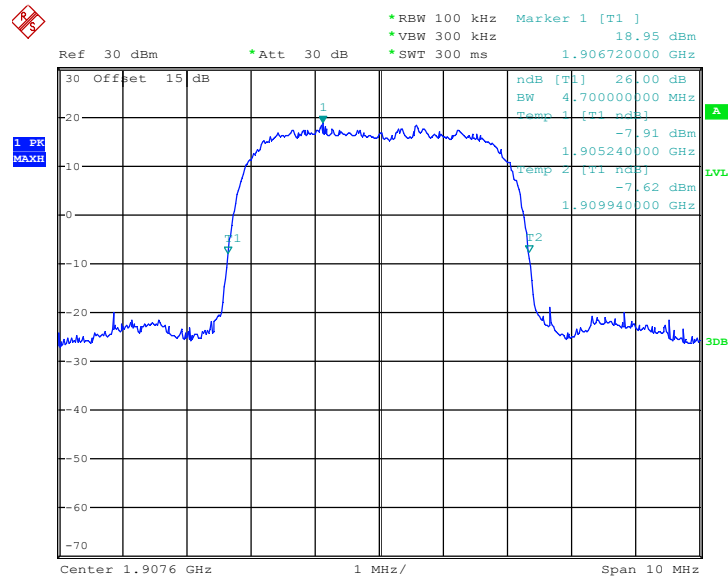

Date: 1.SEP.2015 04:01:30

## 3.5 Band Edge Measurement

### 3.5.1 Description of Band Edge Measurement

The power of any emission outside of the authorized operating frequency ranges must be lower than the transmitter power (P) by a factor of at least  $43 + 10 \log (P)$  dB.

### 3.5.2 Measuring Instruments

The measuring equipment is listed in the section 4 of this test report.

### 3.5.3 Test Procedures

1. The testing follows FCC KDB 971168 v02r02 Section 6.0.
2. The EUT was connected to the spectrum analyzer and system simulator via a power divider.
3. The RF output of EUT was connected to the spectrum analyzer by an RF cable and attenuator. The path loss was compensated to the results for each measurement.
4. The band edges of low and high channels for the highest RF powers were measured.
5. The RF fundamental frequency should be excluded against the limit line in the operating frequency band.
6. The limit line is derived from  $43 + 10\log(P)$  dB below the transmitter power P(Watts)  
 $= P(W) - [43 + 10\log(P)] \text{ (dB)}$   
 $= [30 + 10\log(P)] \text{ (dBm)} - [43 + 10\log(P)] \text{ (dB)}$   
 $= -13\text{dBm}.$

### 3.5.4 Test Setup

<Conducted Band Edge >

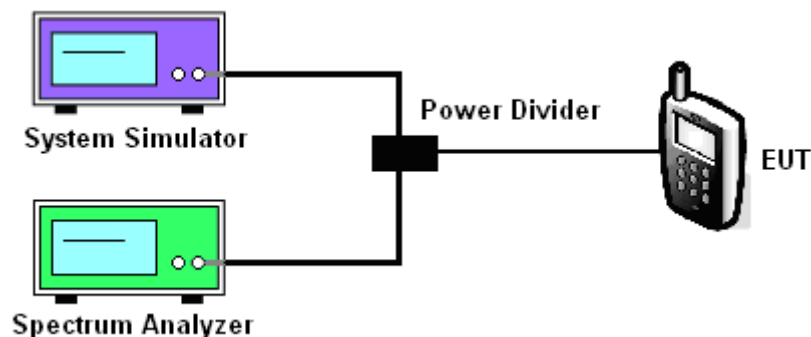



### Test Result (Plots) of Conducted Band Edge

Band :	GSM850	Test Mode :	GSM Link (GMSK)
--------	--------	-------------	-----------------

#### Lower Band Edge Plot on Channel 128 (824.2 MHz)

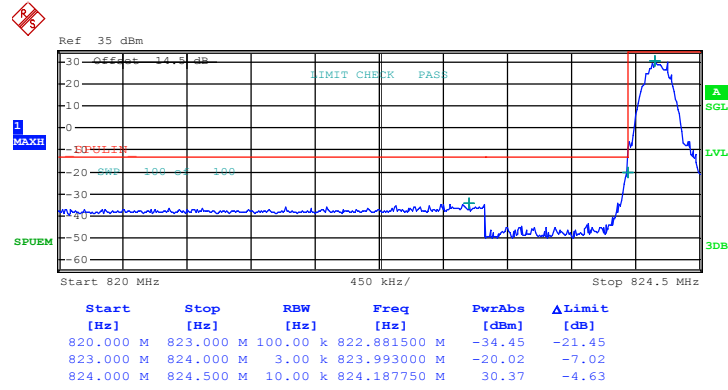

Date: 1.SEP.2015 02:50:07





Band :	GSM850	Test Mode :	GSM Link (GMSK)
--------	--------	-------------	-----------------

Higher Band Edge Plot on Channel 251 (848.8 MHz)

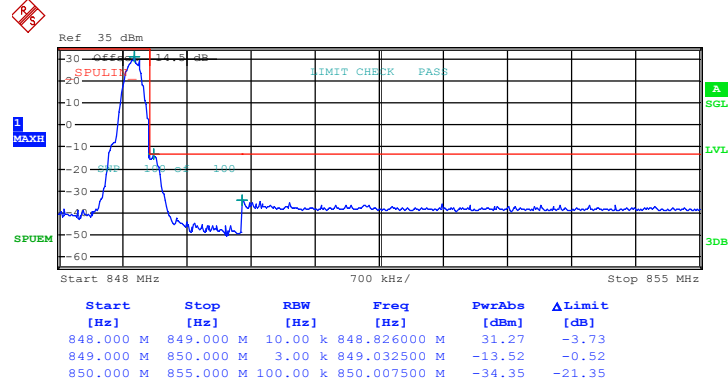

Date: 1.SEP.2015 02:52:09



Band :	GSM1900	Test Mode :	GSM Link (GMSK)
--------	---------	-------------	-----------------

Lower Band Edge Plot on Channel 512 (1850.2 MHz)

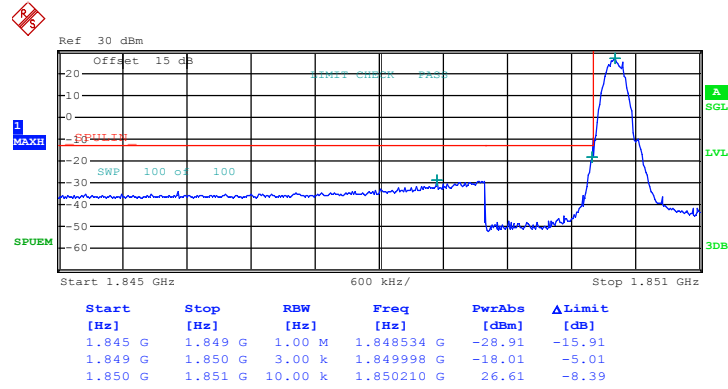

Date: 1.SEP.2015 04:30:01



<b>Band :</b>	GSM1900	<b>Test Mode :</b>	GSM Link (GMSK)
---------------	---------	--------------------	-----------------

Higher Band Edge Plot on Channel 810 (1909.8 MHz)

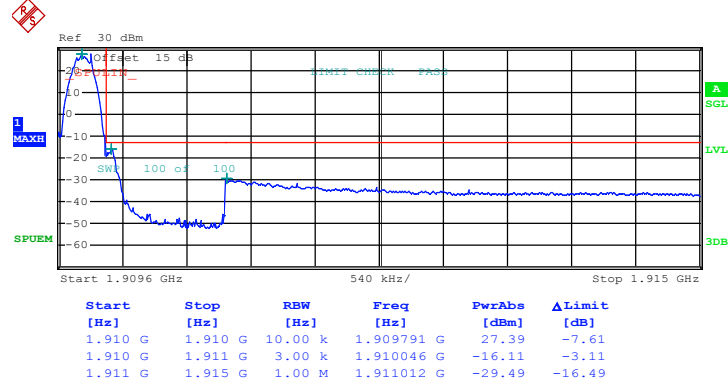

Date: 1.SEP.2015 04:32:37



Band :	WCDMA Band V	Test Mode :	RMC 12.2Kbps Link (QPSK)
--------	--------------	-------------	--------------------------

Lower Band Edge Plot on Channel 4132 (826.4 MHz)

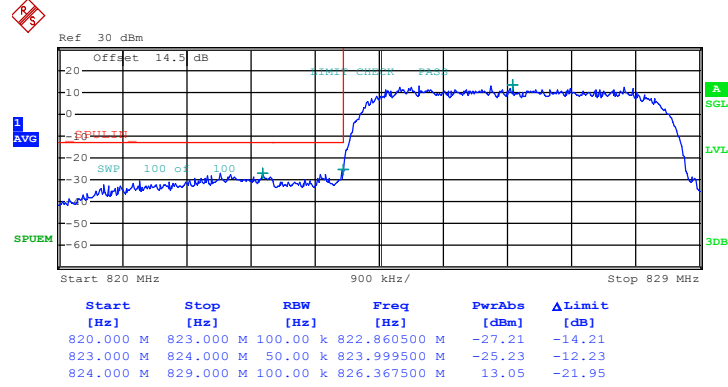

Date: 1.SEP.2015 03:46:13



Band :	WCDMA Band V	Test Mode :	RMC 12.2Kbps Link (QPSK)
--------	--------------	-------------	--------------------------

Higher Band Edge Plot on Channel 4233 (846.6 MHz)

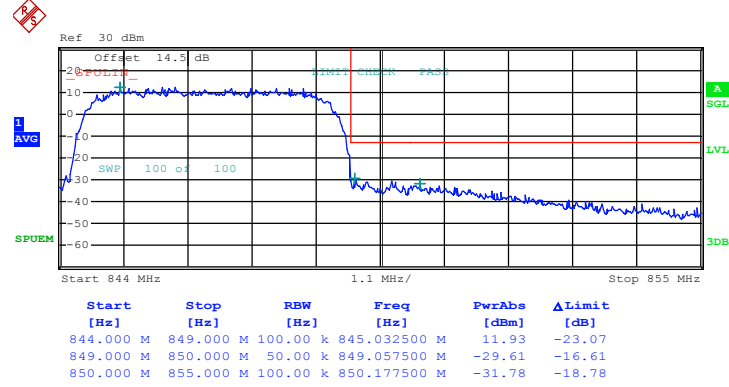

Date: 1.SEP.2015 03:48:13



Band :	WCDMA Band II	Test Mode :	RMC 12.2Kbps Link (QPSK)
--------	---------------	-------------	--------------------------

Lower Band Edge Plot on Channel 9262 (1852.4 MHz)

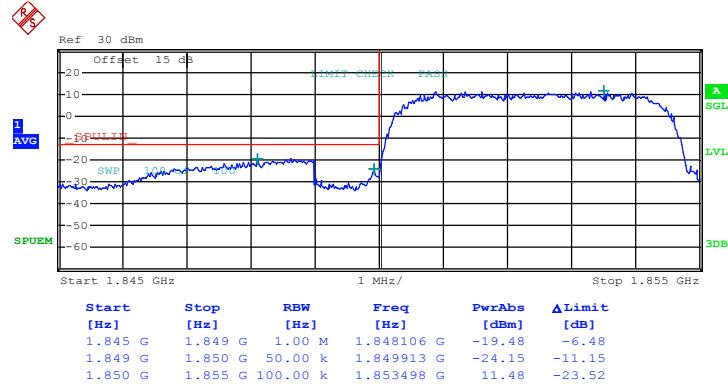

Date: 1.SEP.2015 03:53:22



<b>Band :</b>	WCDMA Band II	<b>Test Mode :</b>	RMC 12.2Kbps Link (QPSK)
---------------	---------------	--------------------	--------------------------

Higher Band Edge Plot on Channel 9538 (1907.6 MHz)

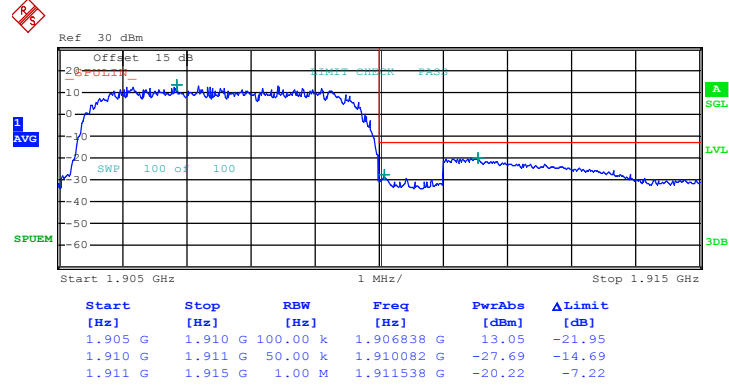

Date: 1.SEP.2015 03:55:40

## 3.6 Conducted Spurious Emission Measurement

### 3.6.1 Description of Conducted Spurious Emission Measurement

The power of any emission outside of the authorized operating frequency ranges must be lower than the transmitter power (P) by a factor of at least  $43 + 10 \log (P)$  dB.

It is measured by means of a calibrated spectrum analyzer and scanned from 30 MHz up to a frequency including its 10<sup>th</sup> harmonic.

### 3.6.2 Measuring Instruments

The measuring equipment is listed in the section 4 of this test report.

### 3.6.3 Test Procedures

1. The testing follows FCC KDB 971168 v02r02 Section 6.0.
2. The EUT was connected to the spectrum analyzer and system simulator via a power divider.
3. The RF output of EUT was connected to the spectrum analyzer by an RF cable and attenuator. The path loss was compensated to the results for each measurement.
4. The middle channel for the highest RF power within the transmitting frequency was measured.
5. The conducted spurious emission for the whole frequency range was taken.
6. The RF fundamental frequency should be excluded against the limit line in the operating frequency band.
7. The limit line is derived from  $43 + 10\log(P)$  dB below the transmitter power P(Watts)  
 $= P(W) - [43 + 10\log(P)]$  (dB)  
 $= [30 + 10\log(P)]$  (dBm) -  $[43 + 10\log(P)]$  (dB)  
 $= -13\text{dBm}$ .

### 3.6.4 Test Setup

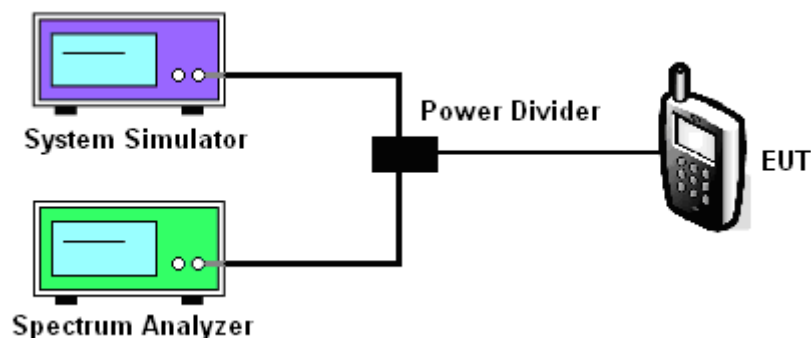





### 3.6.5 Test Result (Plots) of Conducted Spurious Emission

<b>Band :</b>	GSM850	<b>Channel :</b>	CH128
<b>Test Mode :</b>	GSM Link (GMSK)	<b>Frequency :</b>	824.2 MHz

Conducted Spurious Emission Plot between 30MHz ~ 9GHz

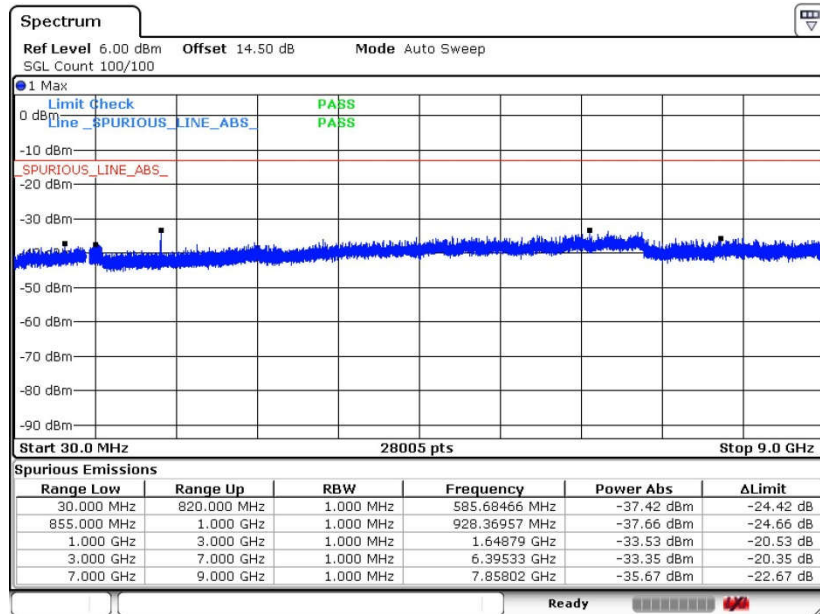

Date: 1.SEP.2015 17:47:30



<b>Band :</b>	GSM850	<b>Channel :</b>	CH189
<b>Test Mode :</b>	GSM Link (GMSK)	<b>Frequency :</b>	836.4 MHz

Conducted Spurious Emission Plot between 30MHz ~ 9GHz

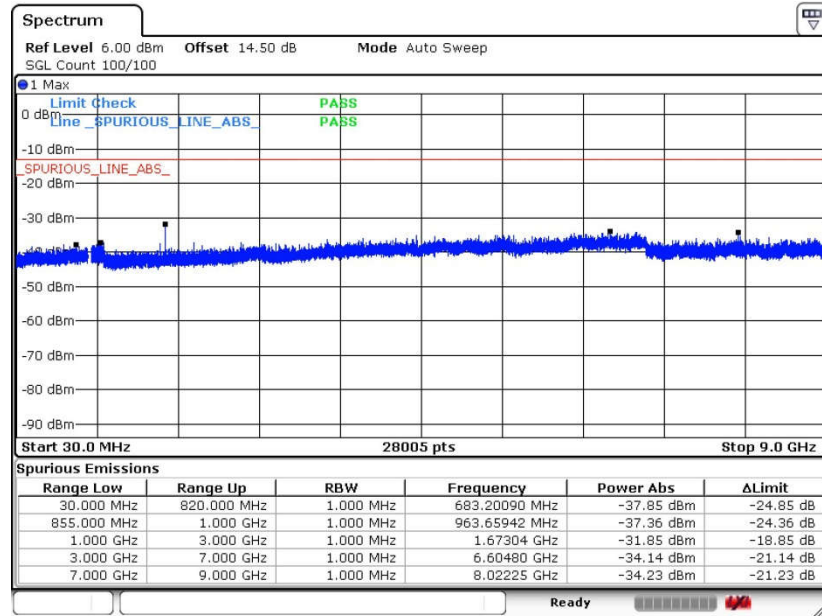

Date: 1.SEP.2015 17:48:17



<b>Band :</b>	GSM850	<b>Channel :</b>	CH 251
<b>Test Mode :</b>	GSM Link (GMSK)	<b>Frequency :</b>	848.8 MHz

Conducted Spurious Emission Plot between 30MHz ~ 9GHz

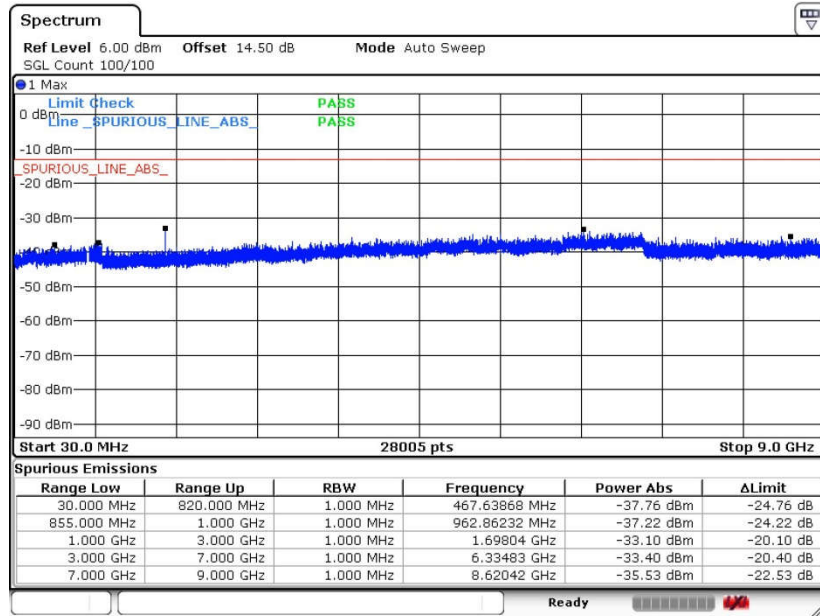

Date: 1.SEP.2015 17:48:45



<b>Band :</b>	GSM1900	<b>Channel :</b>	CH512
<b>Test Mode :</b>	GSM Link (GMSK)	<b>Frequency :</b>	1850.2 MHz

Conducted Spurious Emission Plot between 30MHz ~ 19.1GHz

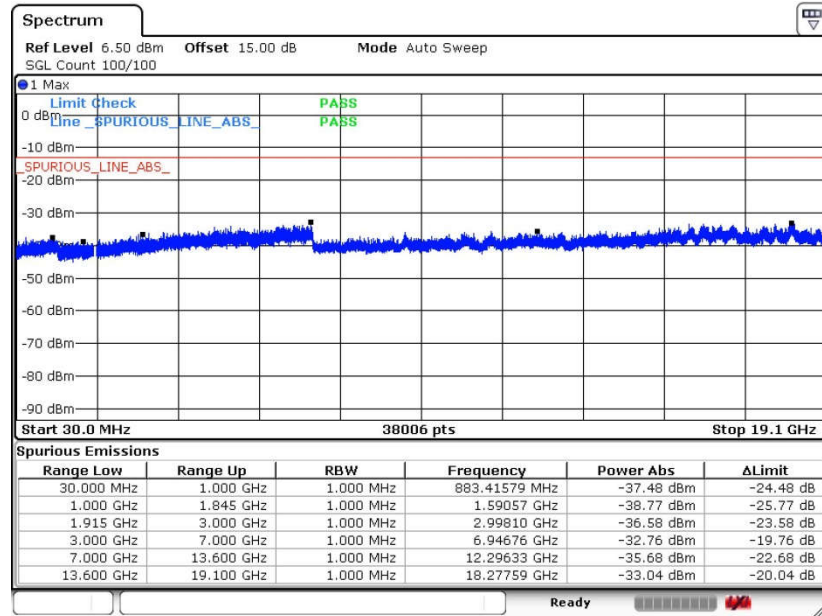

Date: 1.SEP.2015 19:20:01



<b>Band :</b>	GSM1900	<b>Channel :</b>	CH661
<b>Test Mode :</b>	GSM Link (GMSK)	<b>Frequency :</b>	1880.0 MHz

Conducted Spurious Emission Plot between 30MHz ~ 19.1GHz

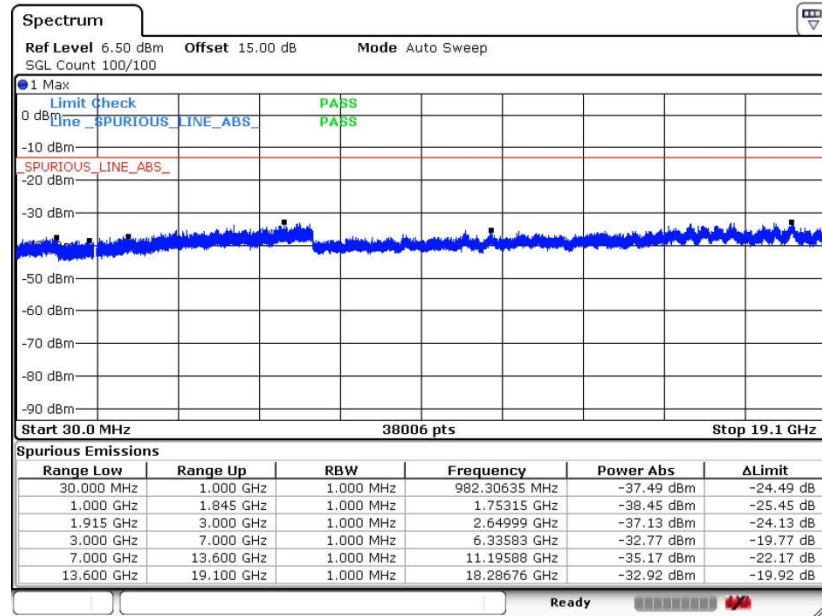

Date: 1.SEP.2015 19:20:43



<b>Band :</b>	GSM1900	<b>Channel :</b>	CH810
<b>Test Mode :</b>	GSM Link (GMSK)	<b>Frequency :</b>	1909.8 MHz

Conducted Spurious Emission Plot between 30MHz ~ 19.1GHz

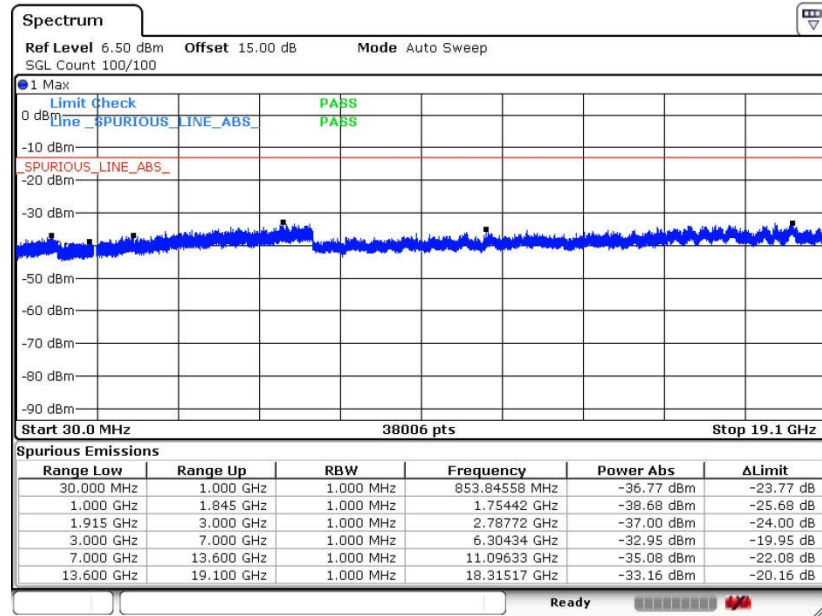

Date: 1.SEP.2015 19:21:35



<b>Band :</b>	WCDMA Band V	<b>Channel :</b>	CH4132
<b>Test Mode :</b>	RMC 12.2Kbps Link (QPSK)	<b>Frequency :</b>	826.4 MHz

Conducted Spurious Emission Plot between 30MHz ~ 9GHz

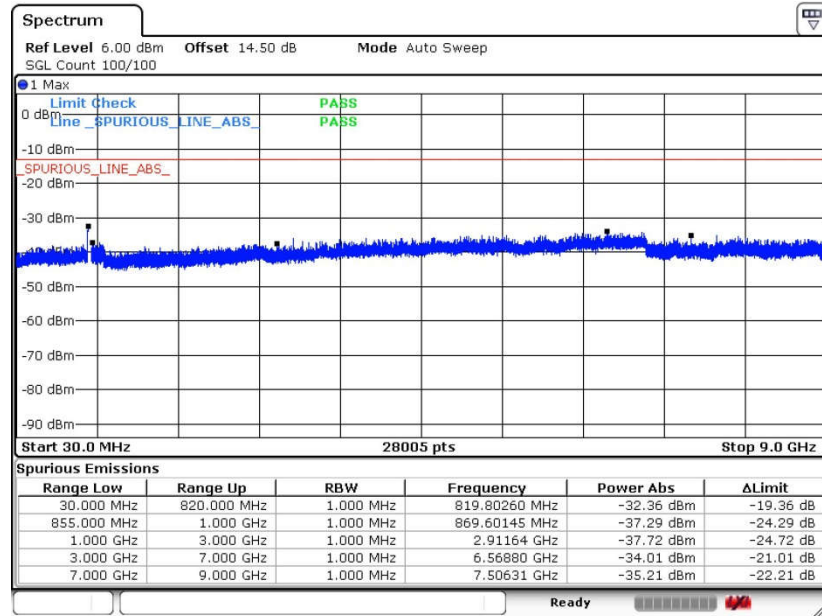

Date: 1.SEP.2015 17:55.44



<b>Band :</b>	WCDMA Band V	<b>Channel :</b>	CH4182
<b>Test Mode :</b>	RMC 12.2Kbps Link (QPSK)	<b>Frequency :</b>	836.4 MHz

Conducted Spurious Emission Plot between 30MHz ~ 9GHz

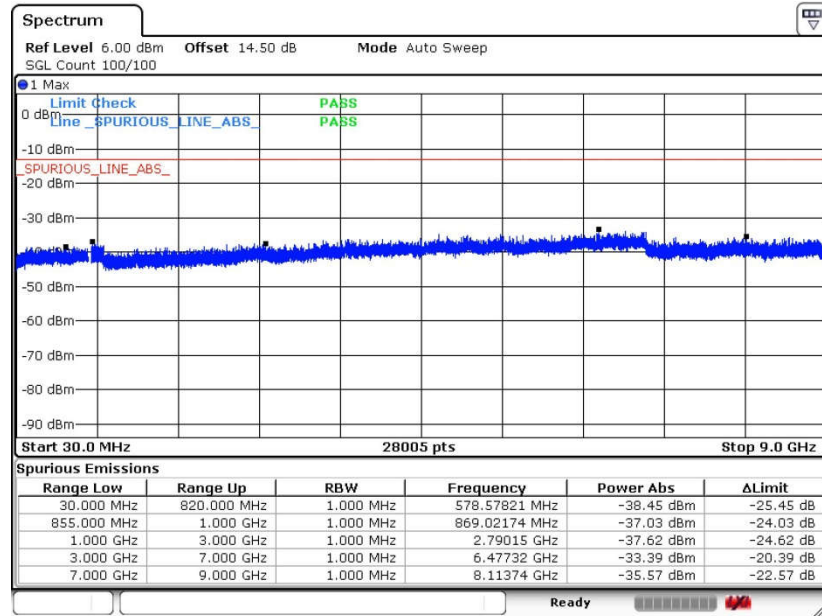

Date: 1.SEP.2015 17:56:19





<b>Band :</b>	WCDMA Band V	<b>Channel :</b>	CH4233
<b>Test Mode :</b>	RMC 12.2Kbps Link (QPSK)	<b>Frequency :</b>	846.6 MHz

Conducted Spurious Emission Plot between 30MHz ~ 9GHz

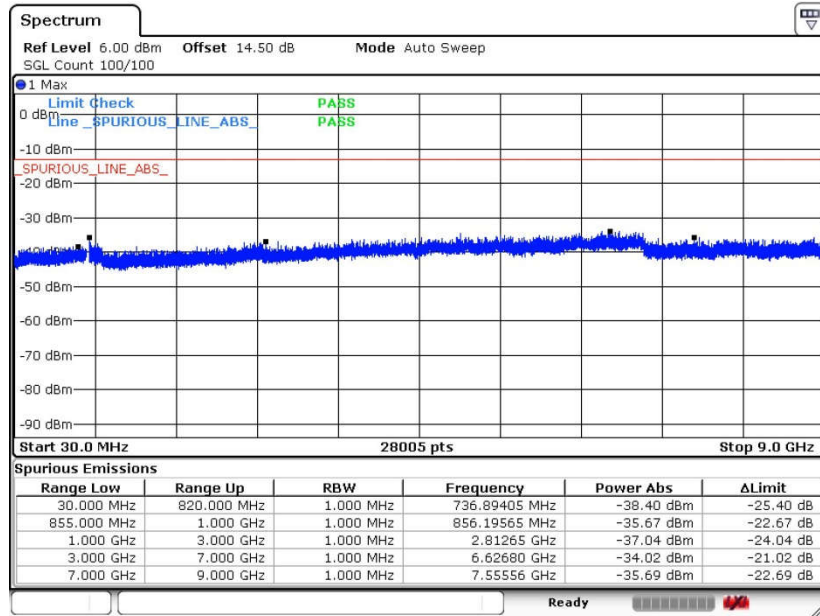

Date: 1.SEP.2015 17:57:20



<b>Band :</b>	WCDMA Band II	<b>Channel :</b>	CH9262
<b>Test Mode :</b>	RMC 12.2Kbps Link (QPSK)	<b>Frequency :</b>	1852.4MHz

Conducted Spurious Emission Plot between 30MHz ~ 19.1GHz

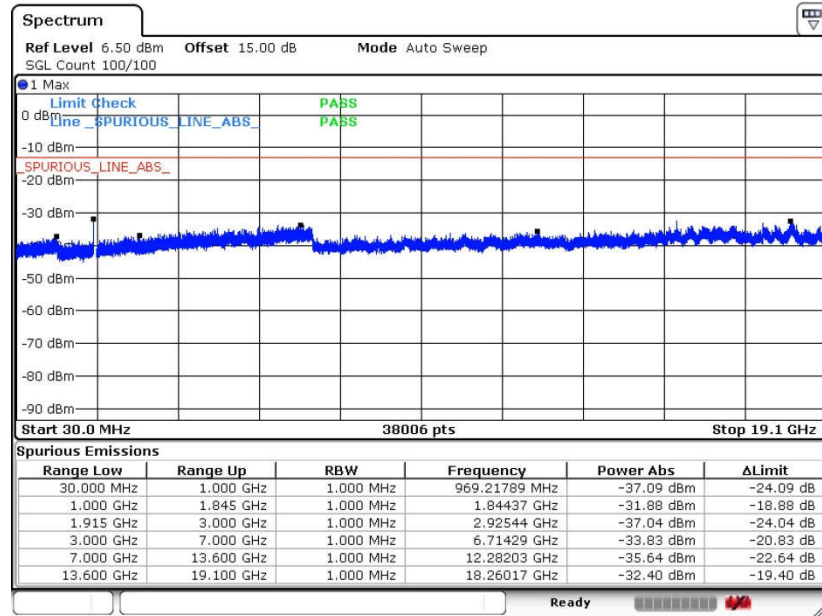

Date: 1.SEP.2015 19:30:27



<b>Band :</b>	WCDMA Band II	<b>Channel :</b>	CH9400
<b>Test Mode :</b>	RMC 12.2Kbps Link (QPSK)	<b>Frequency :</b>	1880.0 MHz

Conducted Spurious Emission Plot between 30MHz ~ 19.1GHz

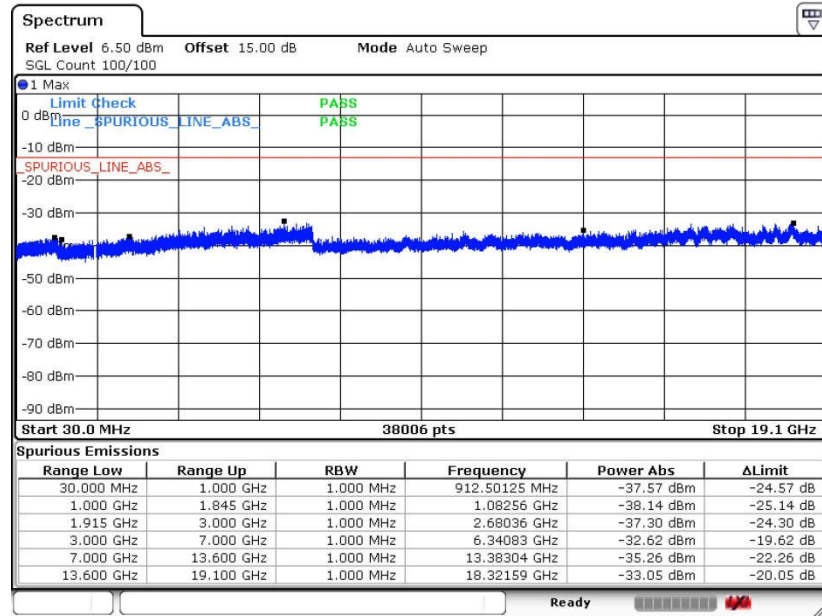

Date: 1.SEP.2015 19:31:21



<b>Band :</b>	WCDMA Band II	<b>Channel :</b>	CH9538
<b>Test Mode :</b>	RMC 12.2Kbps Link (QPSK)	<b>Frequency :</b>	1907.6 MHz

Conducted Spurious Emission Plot between 30MHz ~ 19.1GHz

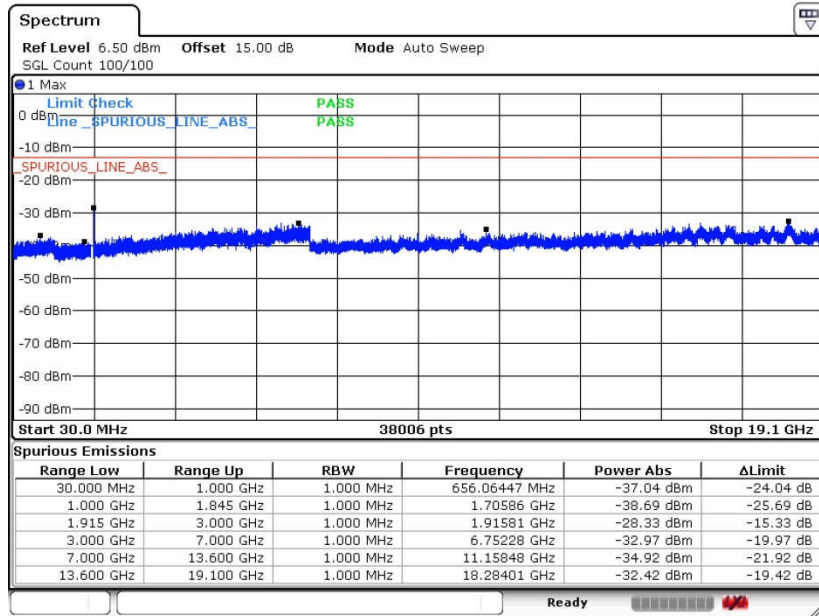

Date: 1.SEP.2015 19:32:10



### 3.7 Field Strength of Spurious Radiation Measurement

#### 3.7.1 Description of Field Strength of Spurious Radiated Measurement

The power of any emission outside of the authorized operating frequency ranges must be attenuated below the transmitter power (P) by a factor of at least  $43 + 10 \log (P)$  dB. The spectrum is scanned from 30 MHz up to a frequency including its 10th harmonic.

#### 3.7.2 Measuring Instruments

The measuring equipment is listed in the section 4 of this test report.

#### 3.7.3 Test Procedures

1. The testing follows FCC KDB 971168 v02r02 Section 5.8 and ANSI / TIA-603-D-2010 Section 2.2.12.
2. The EUT was placed on a rotatable wooden table 0.8 meters above the ground.
3. The EUT was set 3 meters from the receiving antenna, which was mounted on the antenna tower.
4. The table was rotated 360 degrees to determine the position of the highest spurious emission.
5. The height of the receiving antenna is varied between one meter and four meters to search for the maximum spurious emission for both horizontal and vertical polarizations.
6. Make the measurement with the spectrum analyzer's RBW = 1MHz, VBW = 3MHz, taking record of maximum spurious emission.
7. A horn antenna was substituted in place of the EUT and was driven by a signal generator.
8. Tune the output power of signal generator to the same emission level with EUT maximum spurious emission.
9. Taking the record of output power at antenna port.
10. Repeat step 7 to step 8 for another polarization.
11.  $EIRP (dBm) = S.G. Power - Tx Cable Loss + Tx Antenna Gain$
12.  $ERP (dBm) = EIRP - 2.15$
13. The RF fundamental frequency should be excluded against the limit line in the operating frequency band.
14. The limit line is derived from  $43 + 10\log(P)$  dB below the transmitter power P(Watts)  
 $= P(W) - [43 + 10\log(P)] (dB)$   
 $= [30 + 10\log(P)] (dBm) - [43 + 10\log(P)] (dB)$   
 $= -13dBm.$

### 3.7.4 Test Setup

For radiated emissions from 30MHz to 1GHz

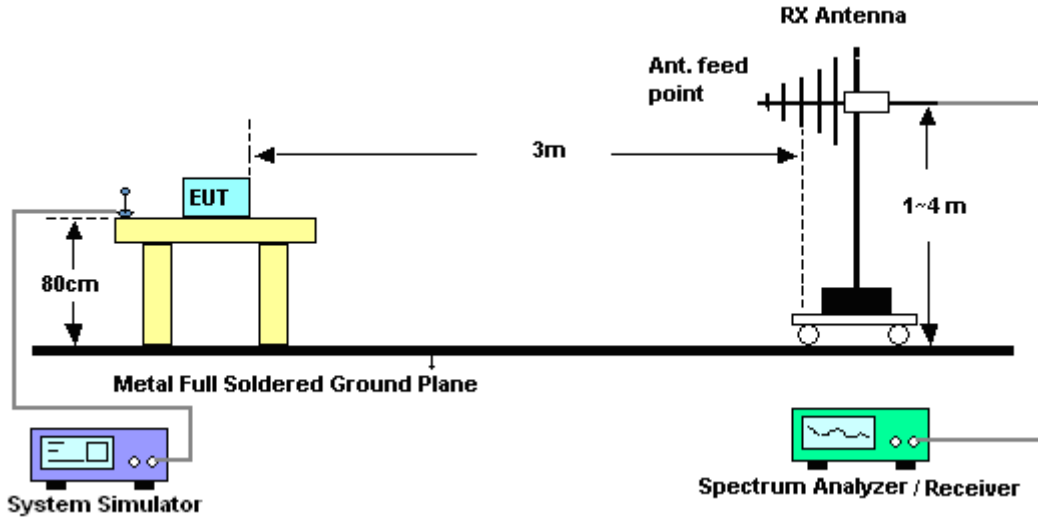

For radiated emissions above 1GHz

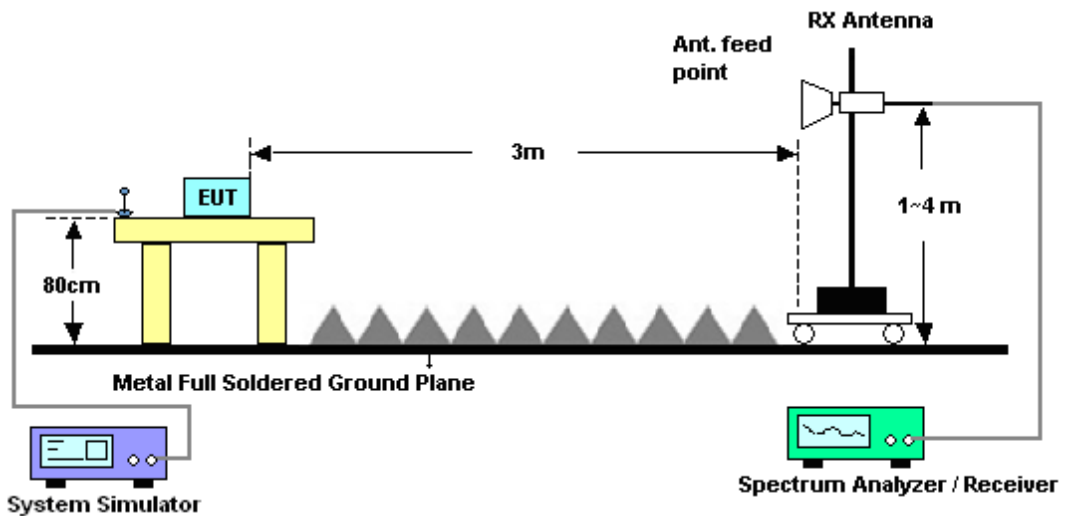



3.7.5 Test Result of Field Strength of Spurious Radiated

<b>Band :</b>	GSM850		<b>Temperature :</b>	22~23°C					
<b>Test Mode :</b>	GSM Link (GMSK)		<b>Relative Humidity :</b>	42~43%					
<b>Test Engineer :</b>	Star Wei		<b>Polarization :</b>	Horizontal					
<b>Remark :</b>	Spurious emissions within 30-1000MHz were found more than 20dB below limit line.								
Frequency ( MHz )	ERP ( dBm )	Limit ( dBm )	Over Limit ( dB )	SPA Reading ( dBm )	S.G. Power ( dBm )	TX Cable loss ( dB )	TX Antenna Gain ( dBi )	Polarization ( H/V )	Result
1674	-49.97	-13	-36.97	-50.62	-51.99	1.73	5.90	H	Pass
2510	-53.04	-13	-40.04	-57.53	-55.58	2.11	6.80	H	Pass
3345	-58.65	-13	-45.65	-63.73	-61.43	2.47	7.40	H	Pass

<b>Band :</b>	GSM850		<b>Temperature :</b>	22~23°C					
<b>Test Mode :</b>	GSM Link (GMSK)		<b>Relative Humidity :</b>	42~43%					
<b>Test Engineer :</b>	Star Wei		<b>Polarization :</b>	Vertical					
<b>Remark :</b>	Spurious emissions within 30-1000MHz were found more than 20dB below limit line.								
Frequency ( MHz )	ERP ( dBm )	Limit ( dBm )	Over Limit ( dB )	SPA Reading ( dBm )	S.G. Power ( dBm )	TX Cable loss ( dB )	TX Antenna Gain ( dBi )	Polarization ( H/V )	Result
1674	-50.22	-13	-37.22	-52.1	-52.24	1.73	5.90	V	Pass
2510	-50.62	-13	-37.62	-56.31	-53.16	2.11	6.80	V	Pass
3345	-58.46	-13	-45.46	-63.75	-61.24	2.47	7.40	V	Pass



<b>Band :</b>	GSM1900		<b>Temperature :</b>	22~23°C					
<b>Test Mode :</b>	GSM Link (GMSK)		<b>Relative Humidity :</b>	42~43%					
<b>Test Engineer :</b>	Star Wei		<b>Polarization :</b>	Horizontal					
<b>Remark :</b>	Spurious emissions within 30-1000MHz were found more than 20dB below limit line.								
Frequency ( MHz )	EIRP ( dBm )	Limit ( dBm )	Over Limit ( dB )	SPA Reading ( dBm )	S.G. Power ( dBm )	TX Cable loss ( dB )	TX Antenna Gain ( dBi )	Polarization ( H/V )	Result
3759	-54.68	-13	-41.68	-64.24	-59.68	2.60	7.60	H	Pass
5640	-51.40	-13	-38.40	-65.39	-58.40	3.10	10.10	H	Pass
7521	-48.49	-13	-35.49	-67.22	-54.65	5.77	11.93	H	Pass

<b>Band :</b>	GSM1900		<b>Temperature :</b>	22~23°C					
<b>Test Mode :</b>	GSM Link (GMSK)		<b>Relative Humidity :</b>	42~43%					
<b>Test Engineer :</b>	Star Wei		<b>Polarization :</b>	Vertical					
<b>Remark :</b>	Spurious emissions within 30-1000MHz were found more than 20dB below limit line.								
Frequency ( MHz )	EIRP ( dBm )	Limit ( dBm )	Over Limit ( dB )	SPA Reading ( dBm )	S.G. Power ( dBm )	TX Cable loss ( dB )	TX Antenna Gain ( dBi )	Polarization ( H/V )	Result
3759	-54.31	-13	-41.31	-64.83	-59.31	2.60	7.60	V	Pass
5640	-51.84	-13	-38.84	-66.3	-58.84	3.10	10.10	V	Pass
7521	-48.50	-13	-35.50	-66.42	-54.66	5.77	11.93	V	Pass





<b>Band :</b>	WCDMA Band V		<b>Temperature :</b>	22~23°C					
<b>Test Mode :</b>	RMC 12.2Kbps Link (QPSK)		<b>Relative Humidity :</b>	42~43%					
<b>Test Engineer :</b>	Star Wei		<b>Polarization :</b>	Horizontal					
<b>Remark :</b>	Spurious emissions within 30-1000MHz were found more than 20dB below limit line.								
Frequency ( MHz )	ERP ( dBm )	Limit ( dBm )	Over Limit ( dB )	SPA Reading ( dBm )	S.G. Power ( dBm )	TX Cable loss ( dB )	TX Antenna Gain ( dBi )	Polarization ( H/V )	Result
1672	-55.68	-13	-42.68	-57.86	-57.57	1.86	5.90	H	Pass
2509	-53.77	-13	-40.77	-62.80	-56.11	2.31	6.80	H	Pass
3345	-53.50	-13	-40.50	-66.13	-55.90	2.85	7.40	H	Pass

<b>Band :</b>	WCDMA Band V		<b>Temperature :</b>	22~23°C					
<b>Test Mode :</b>	RMC 12.2Kbps Link (QPSK)		<b>Relative Humidity :</b>	42~43%					
<b>Test Engineer :</b>	Star Wei		<b>Polarization :</b>	Vertical					
<b>Remark :</b>	Spurious emissions within 30-1000MHz were found more than 20dB below limit line.								
Frequency ( MHz )	ERP ( dBm )	Limit ( dBm )	Over Limit ( dB )	SPA Reading ( dBm )	S.G. Power ( dBm )	TX Cable loss ( dB )	TX Antenna Gain ( dBi )	Polarization ( H/V )	Result
1672	-60.64	-13	-47.64	-59.50	-62.53	1.86	5.90	V	Pass
2509	-52.75	-13	-39.75	-63.72	-55.09	2.31	6.80	V	Pass
3345	-52.46	-13	-39.46	-66.44	-54.86	2.85	7.40	V	Pass



<b>Band :</b>	WCDMA Band II		<b>Temperature :</b>	22~23°C					
<b>Test Mode :</b>	RMC 12.2Kbps Link (QPSK)		<b>Relative Humidity :</b>	42~43%					
<b>Test Engineer :</b>	Star Wei		<b>Polarization :</b>	Horizontal					
<b>Remark :</b>	Spurious emissions within 30-1000MHz were found more than 20dB below limit line.								
Frequency ( MHz )	EIRP ( dBm )	Limit ( dBm )	Over Limit ( dB )	SPA Reading ( dBm )	S.G. Power ( dBm )	TX Cable loss ( dB )	TX Antenna Gain ( dBi )	Polarization ( H/V )	Result
3759	-51.87	-13	-38.87	-66.07	-56.47	3	7.60	H	Pass
5640	-47.82	-13	-34.82	-61.61	-54.08	3.84	10.10	H	Pass
7521	-42.52	-13	-29.52	-62.30	-50.02	4.43	11.93	H	Pass

<b>Band :</b>	WCDMA Band II		<b>Temperature :</b>	22~23°C					
<b>Test Mode :</b>	RMC 12.2Kbps Link (QPSK)		<b>Relative Humidity :</b>	42~43%					
<b>Test Engineer :</b>	Star Wei		<b>Polarization :</b>	Vertical					
<b>Remark :</b>	Spurious emissions within 30-1000MHz were found more than 20dB below limit line.								
Frequency ( MHz )	EIRP ( dBm )	Limit ( dBm )	Over Limit ( dB )	SPA Reading ( dBm )	S.G. Power ( dBm )	TX Cable loss ( dB )	TX Antenna Gain ( dBi )	Polarization ( H/V )	Result
3759	-53.12	-13	-40.12	-65.61	-57.72	3	7.60	V	Pass
5640	-49.30	-13	-36.30	-61.71	-55.56	3.84	10.10	V	Pass
7521	-45.23	-13	-32.23	-63.02	-52.73	4.43	11.93	V	Pass



## 3.8 Frequency Stability Measurement

### 3.8.1 Description of Frequency Stability Measurement

The frequency stability shall be measured by variation of ambient temperature and variation of primary supply voltage to ensure that the fundamental emission stays within the authorized frequency block. The frequency stability of the transmitter shall be maintained within  $\pm 0.00025\%$  ( $\pm 2.5\text{ppm}$ ) of the center frequency.

### 3.8.2 Measuring Instruments

The measuring equipment is listed in the section 4 of this test report.

### 3.8.3 Test Procedures for Temperature Variation

1. The testing follows FCC KDB 971168 v02r02 Section 9.0.
2. The EUT was set up in the thermal chamber and connected with the system simulator.
3. With power OFF, the temperature was decreased to  $-30^{\circ}\text{C}$  and the EUT was stabilized before testing. Power was applied and the maximum change in frequency was recorded within one minute.
4. With power OFF, the temperature was raised in  $10^{\circ}\text{C}$  steps up to  $50^{\circ}\text{C}$ . The EUT was stabilized at each step for at least half an hour. Power was applied and the maximum frequency change was recorded within one minute.

### 3.8.4 Test Procedures for Voltage Variation

1. The testing follows FCC KDB 971168 v02r02 Section 9.0.
2. The EUT was placed in a temperature chamber at  $25\pm 5^{\circ}\text{C}$  and connected with the system simulator.
3. The power supply voltage to the EUT was varied from BEP to 115% of the nominal value measured at the input to the EUT.
4. The variation in frequency was measured for the worst case.

### 3.8.5 Test Setup

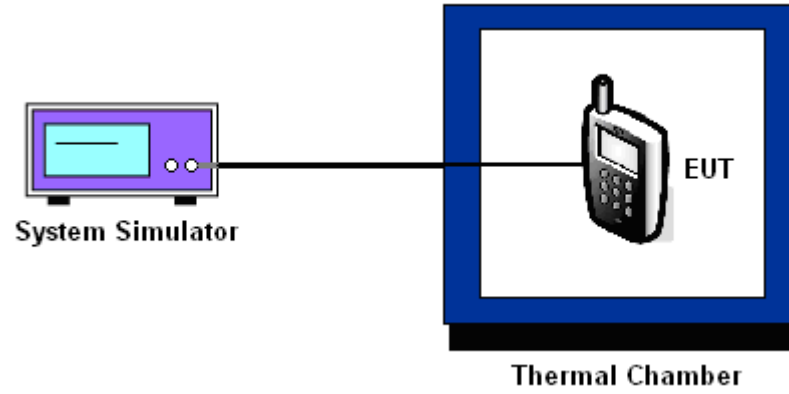



3.8.6 Test Result of Temperature Variation

<b>Band :</b>	GSM 850	<b>Channel :</b>	189
<b>Limit (ppm) :</b>	2.5	<b>Frequency :</b>	836.4 MHz

Temperature (°C)	GSM	Result
	Deviation (ppm)	
50	0.0574	PASS
40	0.0167	
30	0.0430	
20(Ref.)	0.0000	
10	0.0395	
0	0.0143	
-10	0.0132	
-20	0.0275	
-30	0.0574	

<b>Band :</b>	GSM 1900	<b>Channel :</b>	661
<b>Limit (ppm) :</b>	within authorized band	<b>Frequency :</b>	1880.0 MHz

Temperature (°C)	GSM	Result
	Deviation (ppm)	
50	0.0255	PASS
40	0.0160	
30	0.0223	
20(Ref.)	0.0000	
10	0.0005	
0	0.0149	
-10	0.0053	
-20	0.0016	
-30	0.0138	

Note: The frequency fundamental emissions stay within the authorized frequency block based on the frequency deviation measured is small.



<b>Band :</b>	WCDMA Band V	<b>Channel :</b>	4182
<b>Limit (ppm) :</b>	2.5	<b>Frequency :</b>	836.4 MHz

Temperature (°C)	RMC 12.2Kbps		Result
	Deviation (ppm)		
50	0.0670		PASS
40	0.0741		
30	0.0191		
20(Ref.)	0.0000		
10	0.0167		
0	0.0478		
-10	0.0347		
-20	0.0562		
-30	0.0215		

<b>Band :</b>	WCDMA Band II	<b>Channel :</b>	9400
<b>Limit (ppm) :</b>	within authorized band	<b>Frequency :</b>	1880.0 MHz

Temperature (°C)	RMC 12.2Kbps		Result
	Deviation (ppm)		
50	0.0255		PASS
40	0.0245		
30	0.0223		
20(Ref.)	0.0000		
10	0.0074		
0	0.0138		
-10	0.0032		
-20	0.0154		
-30	0.0032		

Note: The frequency fundamental emissions stay within the authorized frequency block based on the frequency deviation measured is small.



3.8.7 Test Result of Voltage Variation

Band & Channel	Mode	Voltage (Volt)	Deviation (ppm)	Limit (ppm)	Result
GSM 850 CH189	GSM	4.3	0.0191	2.5	PASS
		3.8	0.0454		
		BEP	0.0155		
GSM 1900 CH661	GSM	4.3	0.0011	(Note 3.)	
		3.8	0.0016		
		BEP	0.0202		
WCDMA Band V CH4182	RMC 12.2Kbps	4.3	0.0275	2.5	
		3.8	0.0550		
		BEP	0.0646		
WCDMA Band II CH9400	RMC 12.2Kbps	4.3	0.0069	(Note 3.)	
		3.8	0.0005		
		BEP	0.0170		

Note:

1. Normal Voltage = 3.8V.
2. Battery End Point (BEP) = 3.5 V.
3. The frequency fundamental emissions stay within the authorized frequency block based on the frequency deviation measured is small.



## 4 List of Measuring Equipment

Instrument	Manufacturer	Model No.	Serial No.	Characteristics	Calibration Date	Test Date	Due Date	Remark
Spectrum Analyzer	R&S	FSP40	100319	9kHz~40GHz	Oct. 28, 2014	Sep. 01, 2015	Oct. 27, 2015	Conducted (TH01-KS)
Spectrum Analyzer	R&S	FSV30	100845	9kHz~30GHz	Oct. 28, 2014	Sep. 01, 2015	Oct. 27, 2015	Conducted (TH01-KS)
Thermal Chamber	Ten Billion	TTC-B3S	TBN-960502	-40~+150°C	Oct. 25, 2014	Sep. 01, 2015	Oct. 24, 2015	Conducted (TH01-KS)
EMI Test Receiver	R&S	ESR7	101403	9kHz~7GHz; Max 30dBm	Sep. 10, 2015	Sep. 13, 2015~ Oct. 21, 2015	Sep. 09, 2016	Radiation (03CH02-KS)
Spectrum Analyzer	R&S	FSV40	101040	10kHz~40GHz;Ma x 30dBm	Sep. 10, 2015	Sep. 13, 2015~ Oct. 21, 2015	Sep. 09, 2016	Radiation (03CH02-KS)
Bilog Antenna	TeseQ	CBL6112D	37879	30MHz-2GHz	Sep. 12, 2015	Sep. 13, 2015~ Oct. 21, 2015	Sep. 11, 2016	Radiation (03CH02-KS)
Double Ridge Horn Antenna	ETS-Lindgren	3117	75957	1GHz~18GHz	Nov. 08, 2014	Sep. 13, 2015~ Oct. 21, 2015	Nov. 07, 2015	Radiation (03CH02-KS)
Active Horn Antenna	com-power	AHA-118	701030	1GHz~18GHz	Nov. 08, 2014	Sep. 13, 2015~ Oct. 21, 2015	Nov. 07, 2015	Radiation (03CH02-KS)
SHF-EHF Horn	Schwarzbeck	BBHA 9170	BBHA17024 9	15GHz ~40GHz	Mar. 03, 2015	Sep. 13, 2015~ Oct. 21, 2015	Mar. 02, 2016	Radiation (03CH02-KS)
Amplifier	com-power	PA-103A	161069	1kHz~1000MHz / 32 dB	May 04, 2015	Sep. 13, 2015~ Oct. 21, 2015	May 03, 2016	Radiation (03CH02-KS)
Amplifier	Agilent	8449B	3008A02384	1GHz~26.5GHz Gain 30dB	Oct. 28, 2014	Sep. 13, 2015~ Oct. 21, 2015	Oct. 27, 2015	Radiation (03CH02-KS)
AC Power Source	Chroma	61601	6160100024 73	N/A	NCR	Sep. 13, 2015~ Oct. 21, 2015	NCR	Radiation (03CH02-KS)
Turn Table	MF	MF7802	N/A	0~360 degree	NCR	Sep. 13, 2015~ Oct. 21, 2015	NCR	Radiation (03CH02-KS)
Antenna Mast	MF	MF7802	N/A	1 m~4 m	NCR	Sep. 13, 2015~ Oct. 21, 2015	NCR	Radiation (03CH02-KS)





## 5 Uncertainty of Evaluation

### Uncertainty of Radiated Emission Measurement (30 MHz ~ 1000 MHz)

Measuring Uncertainty for a Level of Confidence of 95% ( $U = 2Uc(y)$ )	5.1dB
-------------------------------------------------------------------------	-------