



FCC RF Test Report

APPLICANT : LG Electronics Inc.
EQUIPMENT : Cellular/PCS GSM/WCDMA Phone with WLAN,
Bluetooth
BRAND NAME : LG
MODEL NAME : LG-X170g, X170g, LGX170g, LG-X165g, X165g,
LGX165g
FCC ID : ZNFX170G
STANDARD : FCC Part 15 Subpart C §15.247
CLASSIFICATION : (DTS) Digital Transmission System

The product was received on Mar. 27, 2015 and testing was completed on Apr. 24, 2015. We, SPORTON INTERNATIONAL (KUNSHAN) INC., would like to declare that the tested sample has been evaluated in accordance with the test procedures and has been in compliance with the applicable technical standards.

The test results in this report apply exclusively to the tested model / sample. Without written approval of SPORTON INTERNATIONAL (KUNSHAN) INC., the test report shall not be reproduced except in full.

Reviewed by: Joseph Lin / Supervisor

Approved by: Jones Tsai / Manager



SPORTON INTERNATIONAL (KUNSHAN) INC.
No. 3-2, PingXiang Road, Kunshan, Jiangsu Province, P. R. China



TABLE OF CONTENTS

REVISION HISTORY..... 3

SUMMARY OF TEST RESULT 4

1 GENERAL DESCRIPTION 5

 1.1 Applicant 5

 1.2 Manufacturer 5

 1.3 Product Feature of Equipment Under Test 5

 1.4 Product Specification subjective to this standard 5

 1.5 Modification of EUT 6

 1.6 Testing Location 6

 1.7 Applicable Standards 7

2 TEST CONFIGURATION OF EQUIPMENT UNDER TEST 8

 2.1 Carrier Frequency Channel 8

 2.2 Pre-Scanned RF Power 9

 2.3 Test Mode 10

 2.4 Connection Diagram of Test System 11

 2.5 Support Unit used in test configuration and system 12

 2.6 EUT Operation Test Setup 12

 2.7 Measurement Results Explanation Example 12

3 TEST RESULT 13

 3.1 6dB Bandwidth Measurement 13

 3.2 Output Power Measurement 15

 3.3 Power Spectral Density Measurement 16

 3.4 Conducted Band Edges and Spurious Emission Measurement 18

 3.5 Radiated Band Edges and Spurious Emission Measurement 31

 3.6 AC Conducted Emission Measurement 35

 3.7 Antenna Requirements 39

4 LIST OF MEASURING EQUIPMENT 40

5 UNCERTAINTY OF EVALUATION 41

APPENDIX A. CONDUCTED TEST RESULTS

APPENDIX B. RADIATED TEST RESULTS



REVISION HISTORY

REPORT NO.	VERSION	DESCRIPTION	ISSUED DATE
FR532709C	Rev. 01	Initial issue of report	Jun. 12, 2015



SUMMARY OF TEST RESULT

Report Section	FCC Rule	Description	Limit	Result	Remark
3.1	15.247(a)(2)	6dB Bandwidth	$\geq 0.5\text{MHz}$	Pass	-
3.2	15.247(b)	Power Output Measurement	$\leq 30\text{dBm}$	Pass	-
3.3	15.247(e)	Power Spectral Density	$\leq 8\text{dBm}/3\text{kHz}$	Pass	-
3.4	15.247(d)	Conducted Band Edges	$\leq 20\text{dBc}$	Pass	-
		Conducted Spurious Emission		Pass	-
3.5	15.247(d)	Radiated Band Edges and Radiated Spurious Emission	15.209(a) & 15.247(d)	Pass	Under limit 6.01 dB at 2389.830 MHz
3.6	15.207	AC Conducted Emission	15.207(a)	Pass	Under limit 8.87 dB at 0.560 MHz
3.7	15.203 & 15.247(b)	Antenna Requirement	N/A	Pass	-



1 General Description

1.1 Applicant

LG Electronics Inc.
60-39, Gasan-dong, Gumcheon-gu, Seoul, 153-023, Korea

1.2 Manufacturer

Arima Communications Corp.
6F, No. 866, Jhongjheng Rd., Jhonghe Dist., New Taipei City 23586, Taiwan

1.3 Product Feature of Equipment Under Test

Product Feature	
Equipment	Cellular/PCS GSM/WCDMA Phone with WLAN, Bluetooth
Brand Name	LG
Model Name	LG-X170g, X170g, LGX170g, LG-X165g, X165g, LGX165g
FCC ID	ZNFX170G
EUT supports Radios application	GSM/GPRS/EGPRS(Downlink Only)/ WCDMA/HSPA/HSPA+(Downlink Only) WLAN2.4GHz 802.11b/g/n HT20/HT40 Bluetooth v3.0+EDR/Bluetooth v4.0 LE
IMEI Code	Conducted: 353468062286713/353468062286721 Conduction: 353468062286739/353468062286747 Radiated: 353468062286671/353468062286689
HW Version	v0.2
SW Version	v08a
EUT Stage	Production Unit

Remark: The above EUT's information was declared by manufacturer. Please refer to the specifications or user's manual for more detailed description.

1.4 Product Specification subjective to this standard

Product Specification subjective to this standard	
Tx/Rx Channel Frequency Range	802.11b/g/n : 2412 MHz ~ 2462 MHz
Maximum (Peak) Output Power to Antenna	802.11b : 18.86 dBm (0.0769 W) 802.11g : 21.73 dBm (0.1489 W) 802.11n HT20 : 20.15 dBm (0.1035 W) 802.11n HT40 : 21.32 dBm (0.1355 W)
Antenna Type	802.11b/g/n : IFA Antenna with gain 1.61 dBi
Type of Modulation	802.11b : DSSS (DBPSK / DQPSK / CCK) 802.11g/n : OFDM (BPSK / QPSK / 16QAM / 64QAM)



1.5 Modification of EUT

No modifications are made to the EUT during all test items.

1.6 Testing Location

Sporton Lab is accredited to ISO 17025 by Taiwan Accreditation Foundation (TAF code : 1190) and the FCC designation No. TW1022 under the FCC 2.948(e) by Mutual Recognition Agreement (MRA) in FCC Test.

Test Site	SPORTON INTERNATIONAL INC.	
Test Site Location	No. 52, Hwa Ya 1 st Rd., Hwa Ya Technology Park, Kwei-Shan District, Tao Yuan City, Taiwan, R.O.C. TEL: +886-3-327-3456 FAX: +886-3-328-4978	
Test Site No.	Sporton Site No.	
	03CH07-HY	

Test Site	SPORTON INTERNATIONAL (KUNSHAN) INC.	
Test Site Location	No. 3-2, PingXiang Road, Kunshan, Jiangsu Province, P. R. China TEL: +86-0512-5790-0158 FAX: +86-0512-5790-0958	
Test Site No.	Sporton Site No.	
	TH01-KS	CO01-KS

Note: The test site complies with ANSI C63.4 2009 requirement.



1.7 Applicable Standards

According to the specifications of the manufacturer, the EUT must comply with the requirements of the following standards:

- ♦ FCC Part 15 Subpart C §15.247
- ♦ FCC KDB Publication No. 558074 D01 DTS Meas. Guidance v03r02
- ♦ ANSI C63.10-2013

Remark:

1. All test items were verified and recorded according to the standards and without any deviation during the test.
2. FCC permits the use of the 1.5 meter table as an alternative in C63.10-2013 through inquiry tracking number 961829.
3. This EUT has also been tested and complied with the requirements of FCC Part 15, Subpart B, recorded in a separate test report.



2 Test Configuration of Equipment Under Test

The EUT has been associated with peripherals and configuration operated in a manner tended to maximize its emission characteristics in a typical application. Frequency range investigated: conducted emission (150 kHz to 30 MHz) and radiated emission (9 kHz to the 10th harmonic of the highest fundamental frequency or to 40 GHz, whichever is lower). For radiated measurement, pre-scanned in three orthogonal panels, X, Y, Z. The worst cases (Z plane) were recorded in this report.

The final configuration from all the combinations and the worst-case data rates were investigated by measuring the maximum power across all the data rates and modulation modes under section 2.2.

Based on the worst configuration found above, the RF power setting is set individually to meet FCC compliance limit for the final conducted and radiated tests shown in section 2.3.

2.1 Carrier Frequency Channel

Frequency Band	Channel	Freq. (MHz)	Channel	Freq. (MHz)
2400-2483.5 MHz	1	2412	7	2442
	2	2417	8	2447
	3	2422	9	2452
	4	2427	10	2457
	5	2432	11	2462
	6	2437	-	-



2.2 Pre-Scanned RF Power

Preliminary tests were performed in different data rate and data rate associated with the highest power were chosen for full test shown in the following tables.

2.4GHz 802.11b mode				
Data Rate (MHz)	1M bps	2M bps	5.5M bps	11M bps
Peak Power (dBm)	18.86	18.83	18.31	18.82

2.4GHz 802.11g mode								
Data Rate (MHz)	6M bps	9M bps	12M bps	18M bps	24M bps	36M bps	48M bps	54M bps
Peak Power (dBm)	21.73	21.66	21.51	21.65	21.25	21.61	21.12	21.56

2.4GHz 802.11n HT20 mode								
Data Rate (MHz)	MCS0	MCS1	MCS2	MCS3	MCS4	MCS5	MCS6	MCS7
Peak Power (dBm)	20.15	20.06	19.52	19.62	19.83	19.06	19.73	19.67

2.4GHz 802.11n HT40 mode								
Data Rate (MHz)	MCS0	MCS1	MCS2	MCS3	MCS4	MCS5	MCS6	MCS7
Peak Power (dBm)	21.32	19.58	19.37	19.54	19.77	19.79	19.55	19.77



2.3 Test Mode

Final test mode of conducted test items and radiated spurious emissions are considering the modulation and worse data rates from the power table described in section 2.2.

<2.4GHz>

Modulation	Data Rate
802.11b	1 Mbps
802.11g	6 Mbps
802.11n HT20	MCS0
802.11n HT40	MCS0

Test Cases	
AC Conducted	Mode 1 : GSM850 Idle + Bluetooth Link + WLAN Link + Earphone + USB Cable (Charging from Adapter 1) +
Emission	SIM 1
Remark: For Radiated Test Cases, The tests were performance with Adapter 1, Earphone, and USB Cable.	

2.4 Connection Diagram of Test System

<WLAN Tx Mode>

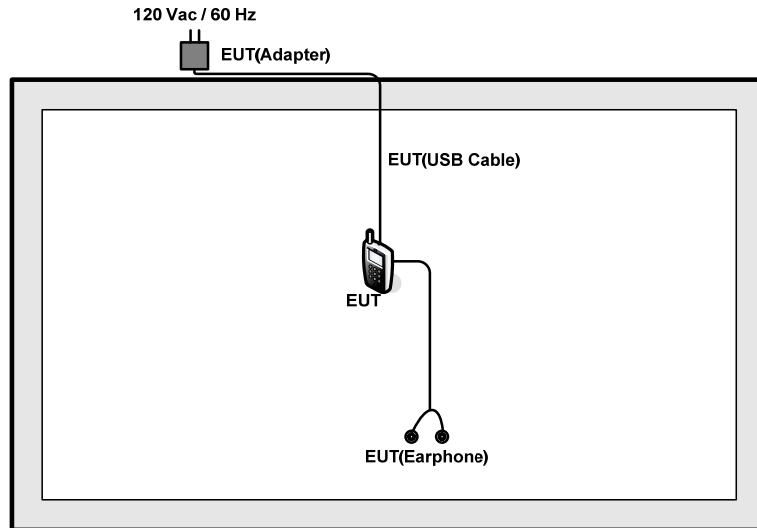

<AC Conducted Emission Mode>

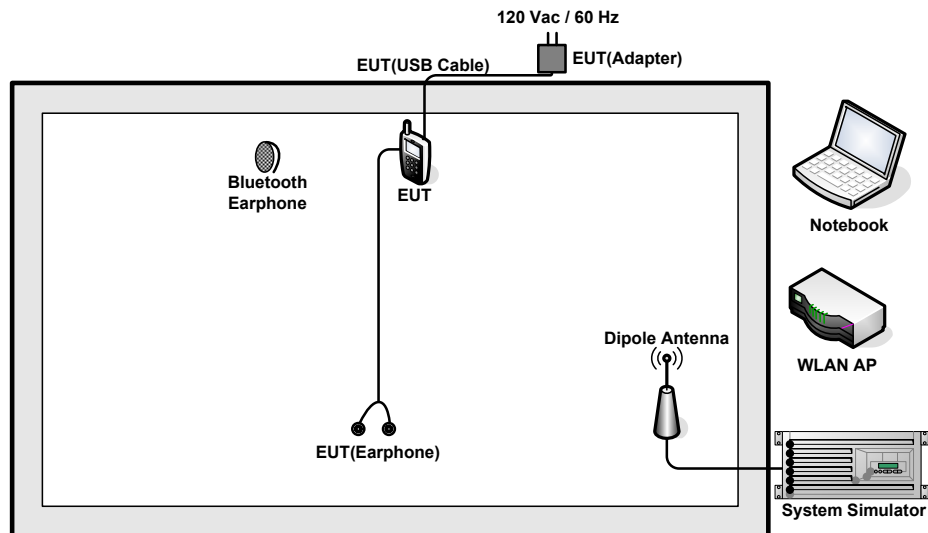

2.5 Support Unit used in test configuration and system

Item	Equipment	Trade Name	Model Name	FCC ID	Data Cable	Power Cord
1.	System Simulator	R&S	CMU 200	N/A	N/A	Unshielded, 1.8 m
2.	WLAN AP	LINKSYS	WRT600N	Q87-WRT600NV11	N/A	Unshielded, 1.8 m
3.	Notebook	Lenovo	G480	PRC4	N/A	AC I/P: Unshielded, 1.2 m DC O/P: Shielded, 1.8 m
4.	Bluetooth Earphone	Nokia	BH-1026	QTLBH-106	N/A	N/A

2.6 EUT Operation Test Setup

For WLAN RF test items, an engineering test program was provided and enabled to make EUT continuously transmit/receive.

For AC power line conducted emissions, the EUT was set to connect with the WLAN AP under large package sizes transmission.

2.7 Measurement Results Explanation Example

For all conducted test items:

The offset level is set in the spectrum analyzer to compensate the RF cable loss between EUT conducted output port and spectrum analyzer. With the offset compensation, the spectrum analyzer reading level is exactly the EUT RF output level.

Example :

The spectrum analyzer offset is derived from RF cable loss.

Offset = RF cable loss.

Following shows an offset computation example with cable loss 5.5 dB.

$$\begin{aligned} \text{Offset(dB)} &= \text{RF cable loss(dB)}. \\ &= 5.5 \text{ (dB)} \end{aligned}$$

3 Test Result

3.1 6dB Bandwidth Measurement

3.1.1 Limit of 6dB Bandwidth

The minimum 6 dB bandwidth shall be at least 500 kHz.

3.1.2 Measuring Instruments

The measuring equipment is listed in the section 4 of this test report.

3.1.3 Test Procedures

1. The testing follows FCC KDB Publication No. 558074 DTS D01 Meas. Guidance v03r02.
2. The RF output of EUT was connected to the spectrum analyzer by RF cable and attenuator. The path loss was compensated to the results for each measurement.
3. Set to the maximum power setting and enable the EUT transmit continuously.
4. Make the measurement with the spectrum analyzer's resolution bandwidth (RBW) = 100 kHz. Set the Video bandwidth (VBW) = 300 kHz. In order to make an accurate measurement. The 6 dB bandwidth must be greater than 500 kHz.
5. Measure and record the results in the test report.

3.1.4 Test Setup





3.1.5 Test Result of 6dB Bandwidth

Please refer to Appendix A of this test report.

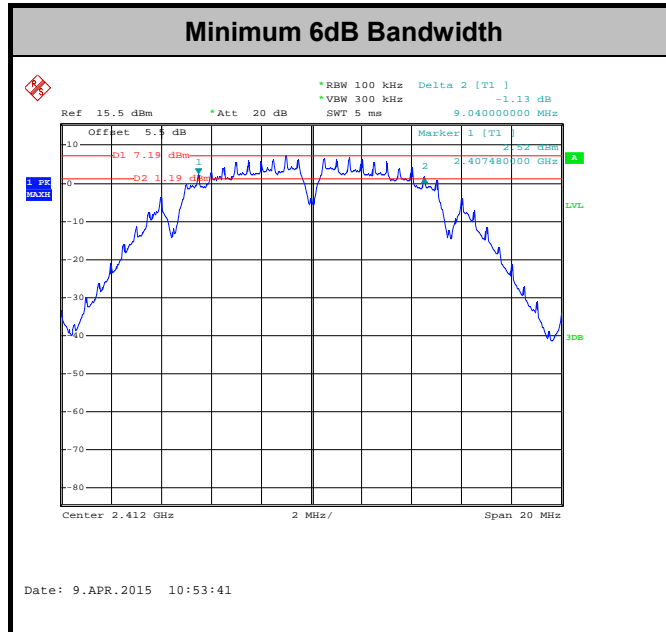

3.2 Output Power Measurement

3.2.1 Limit of Output Power

For systems using digital modulation in the 2400-2483.5MHz, the limit for peak output power is 30dBm. If transmitting Antenna of directional gain greater than 6dBi are used the peak output power from the intentional radiator shall be reduced below the above stated value by the amount in dB that the directional gain of the Antenna exceeds 6 dBi. In case of point-to-point operation, the limit has to be reduced by 1dB for every 3dB that the directional gain of the Antenna exceeds 6dBi.

3.2.2 Measuring Instruments

The measuring equipment is listed in the section 4 of this test report.

3.2.3 Test Procedures

1. The testing follows the Measurement Procedure of FCC KDB No. 558074 DTS D01 Meas. Guidance v03r02.
2. The RF output of EUT was connected to the power meter by RF cable and attenuator. The path loss was compensated to the results for each measurement.
3. Set to the maximum power setting and enable the EUT transmit continuously.
4. Measure the conducted output power and record the results in the test report.

3.2.4 Test Setup

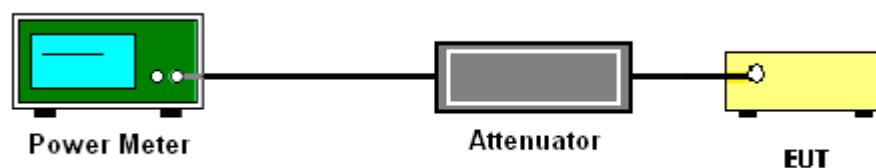

3.2.5 Test Result of Peak Output Power

Please refer to Appendix A of this test report.

3.2.6 Test Result of Average output Power (Reporting Only)

Please refer to Appendix A of this test report.

3.3 Power Spectral Density Measurement

3.3.1 Limit of Power Spectral Density

The peak power spectral density shall not be greater than 8dBm in any 3kHz band at any time interval of continuous transmission.

3.3.2 Measuring Instruments

The measuring equipment is listed in the section 4 of this test report.

3.3.3 Test Procedures

1. The testing follows Measurement Procedure 10.2 Method PKPSD of FCC KDB Publication No. 558074 D01 DTS Meas. Guidance v03r02
2. The RF output of EUT was connected to the spectrum analyzer by RF cable and attenuator. The path loss was compensated to the results for each measurement.
3. Set to the maximum power setting and enable the EUT transmit continuously.
4. Make the measurement with the spectrum analyzer's resolution bandwidth (RBW) = 3 kHz. Video bandwidth VBW = 10 kHz In order to make an accurate measurement, set the span to 1.5 times DTS Channel Bandwidth. (6dB BW)
5. Detector = peak, Sweep time = auto couple, Trace mode = max hold, Allow trace to fully stabilize. Use the peak marker function to determine the maximum power level.
6. Measure and record the results in the test report.

3.3.4 Test Setup

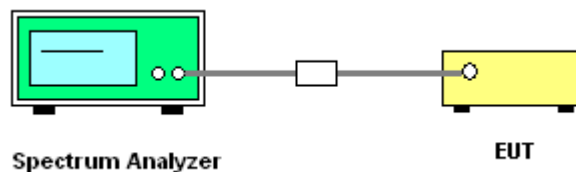



3.3.5 Test Result of Power Spectral Density

Please refer to Appendix A of this test report.

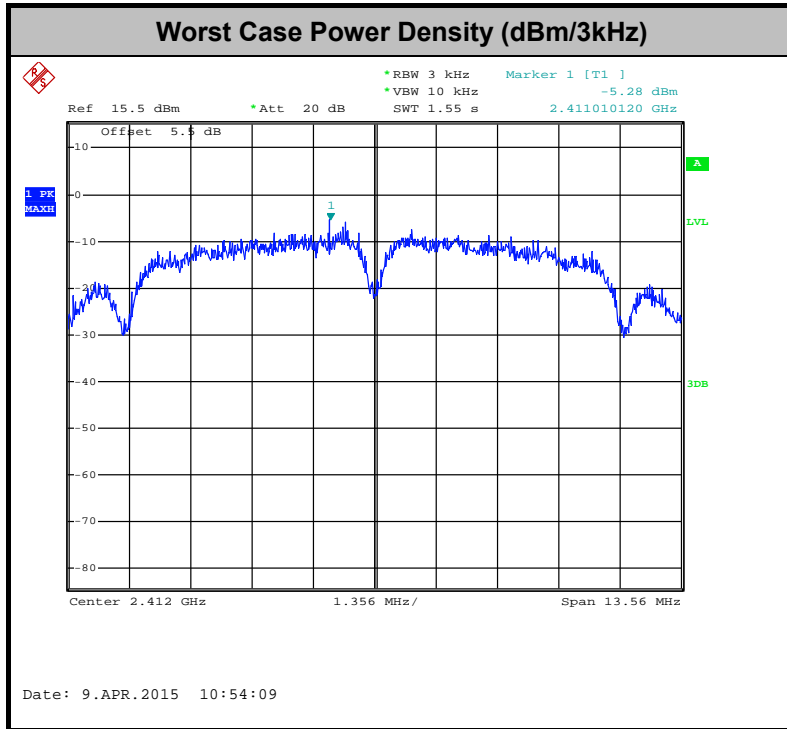

3.4 Conducted Band Edges and Spurious Emission Measurement

3.4.1 Limit of Conducted Band Edges and Spurious Emission Measurement

In any 100 kHz bandwidth outside of the authorized frequency band, the emissions which fall in the non-restricted bands shall be attenuated at least 20 dB / 30dB relative to the maximum PSD level in 100 kHz by RF conducted measurement and radiated emissions which fall in the restricted bands, as defined in Section 15.205(a), must also comply with the radiated emission limits specified in Section 15.209(a).

3.4.2 Measuring Instruments

The measuring equipment is listed in the section 4 of this test report.

3.4.3 Test Procedures

1. The testing follows FCC KDB Publication No. 558074 D01 DTS Meas. Guidance v03r02.
2. The RF output of EUT was connected to the spectrum analyzer by RF cable and attenuator. The path loss was compensated to the results for each measurement.
3. Set to the maximum power setting and enable the EUT transmit continuously.
4. Set RBW = 100 kHz, VBW=300 kHz, Peak Detector. Unwanted Emissions measured in any 100 kHz bandwidth outside of the authorized frequency band shall be attenuated by at least 20 dB relative to the maximum in-band peak PSD level in 100 kHz when maximum peak conducted output power procedure is used. If the transmitter complies with the conducted power limits based on the use of RMS averaging over a time interval, the attenuation required under this paragraph shall be 30 dB instead of 20 dB per 15.247(d).
5. Measure and record the results in the test report.
6. The RF fundamental frequency should be excluded against the limit line in the operating frequency band.

3.4.4 Test Setup

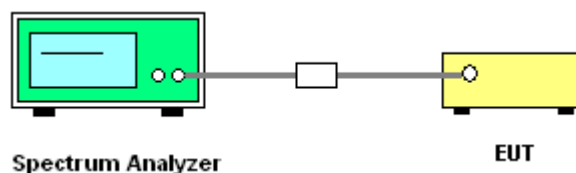



3.4.5 Test Result of Conducted Band Edges and Spurious Emission

Test Mode :	802.11b	Temperature :	21~25°C
Test Band :	2.4GHz Low	Relative Humidity :	51~54%
Test Channel :	01	Test Engineer :	Issac Song

WLAN 802.11b Channel 01

100kHz PSD reference Level	Low Channel Plot
-----------------------------------	-------------------------

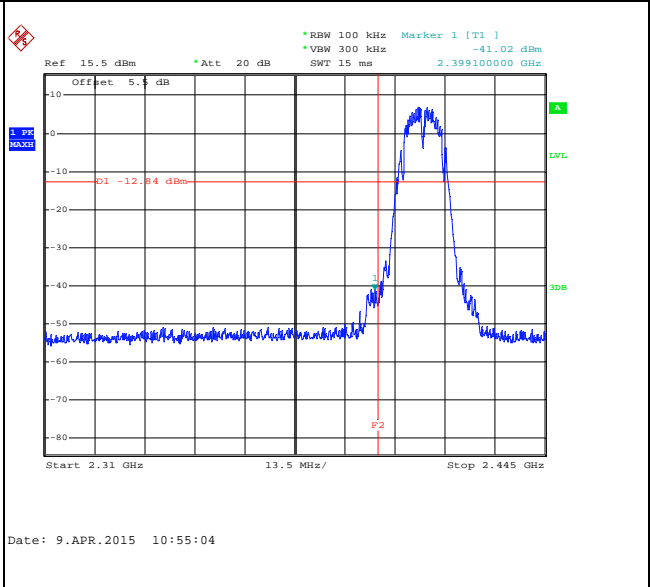
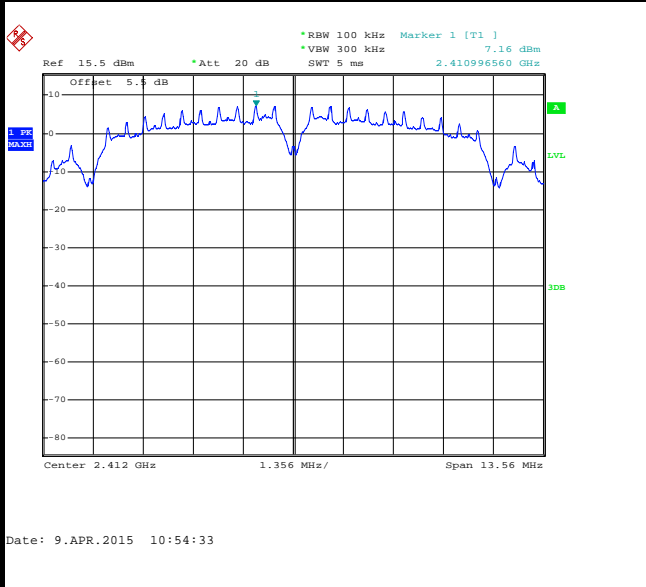

Spurious Emission 30MHz~3GHz

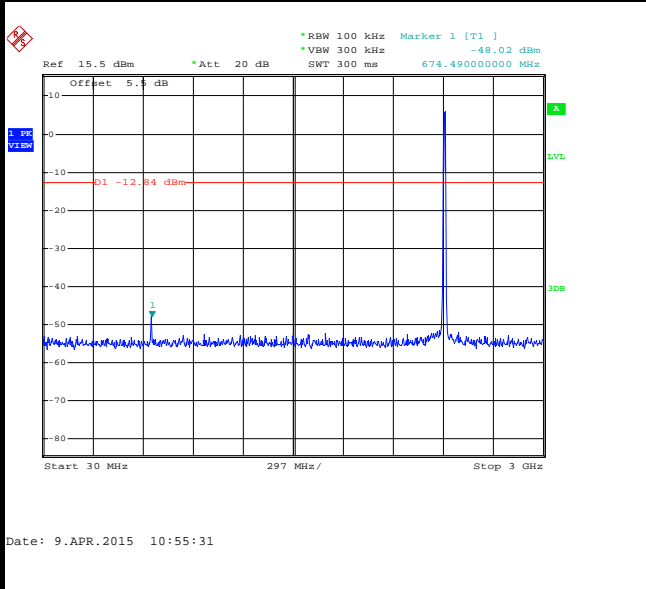

Spurious Emission 2GHz~25GHz

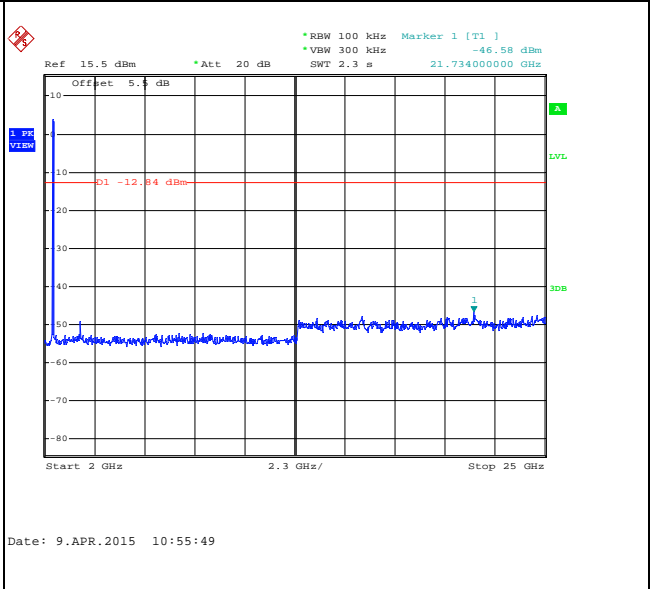



Test Mode :	802.11b	Temperature :	21~25°C
Test Band :	2.4GHz Mid	Relative Humidity :	51~54%
Test Channel :	06	Test Engineer :	Issac Song

WLAN 802.11b Channel 06

100kHz PSD reference Level

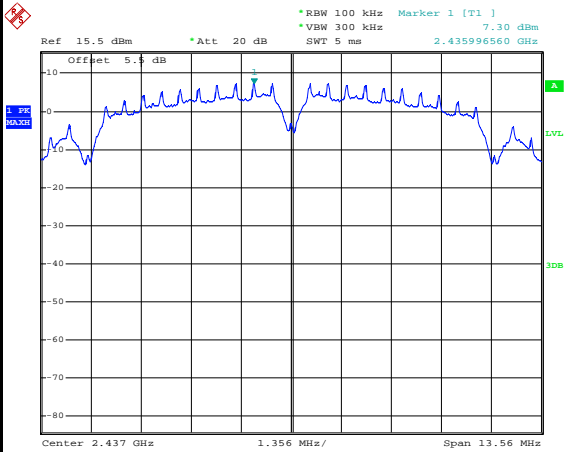

Date: 9.APR.2015 11:04:42

Spurious Emission 30MHz~3GHz

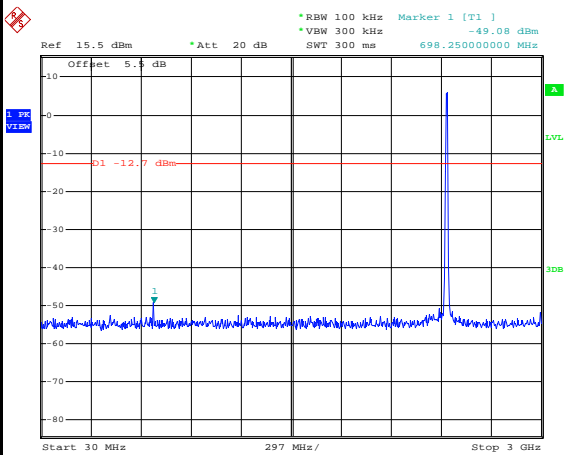

Date: 9.APR.2015 11:05:07

Spurious Emission 2GHz~25GHz

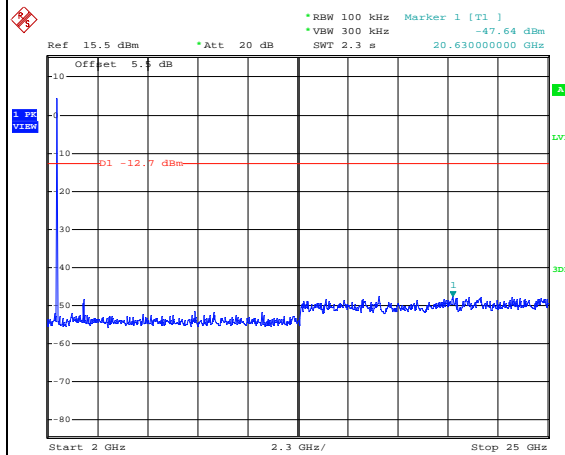

Date: 9.APR.2015 11:05:25



Test Mode :	802.11b	Temperature :	21~25°C
Test Band :	2.4GHz High	Relative Humidity :	51~54%
Test Channel :	11	Test Engineer :	Issac Song

WLAN 802.11b Channel 11

100kHz PSD reference Level

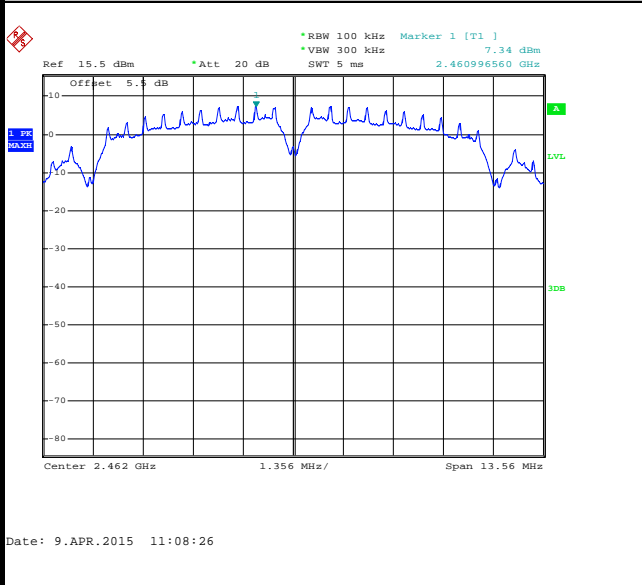

High Channel Plot

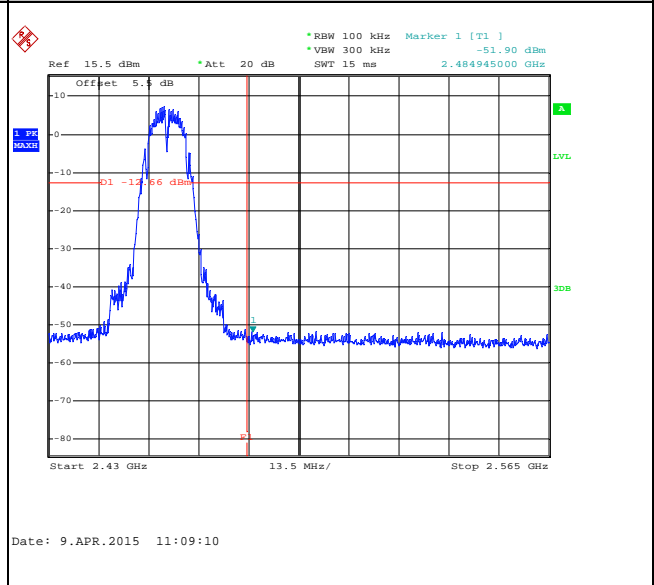

Spurious Emission 30MHz~3GHz

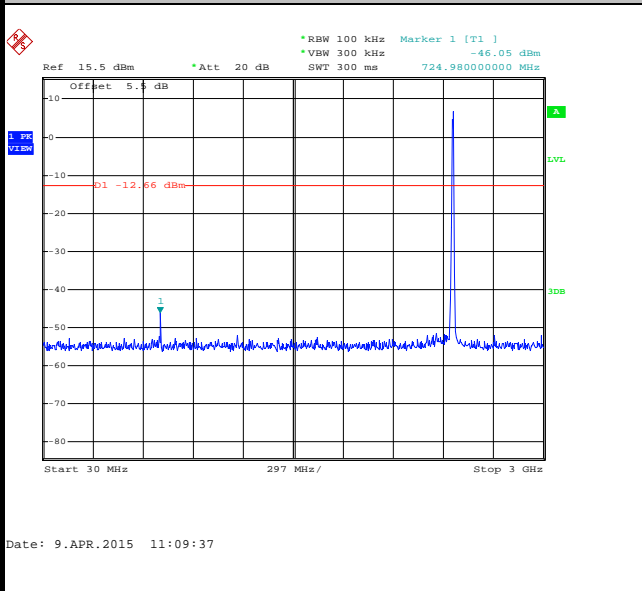

Spurious Emission 2GHz~25GHz

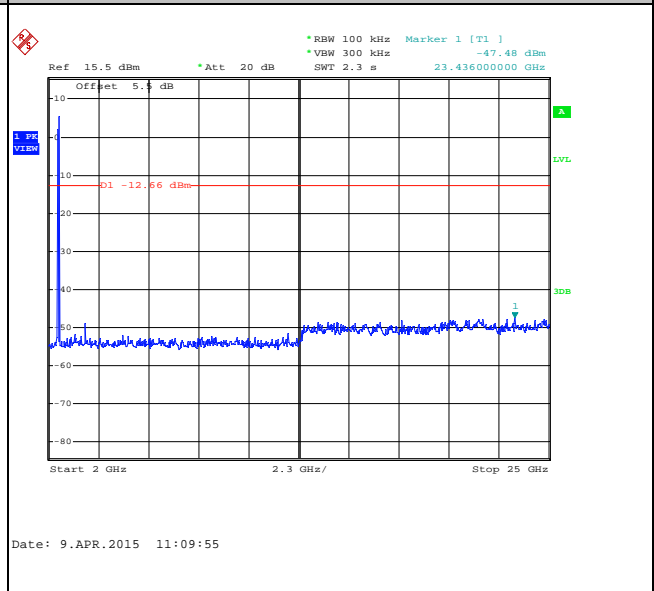



Test Mode :	802.11g	Temperature :	21~25°C
Test Band :	2.4GHz Low	Relative Humidity :	51~54%
Test Channel :	01	Test Engineer :	Issac Song

WLAN 802.11g Channel 01

100kHz PSD reference Level

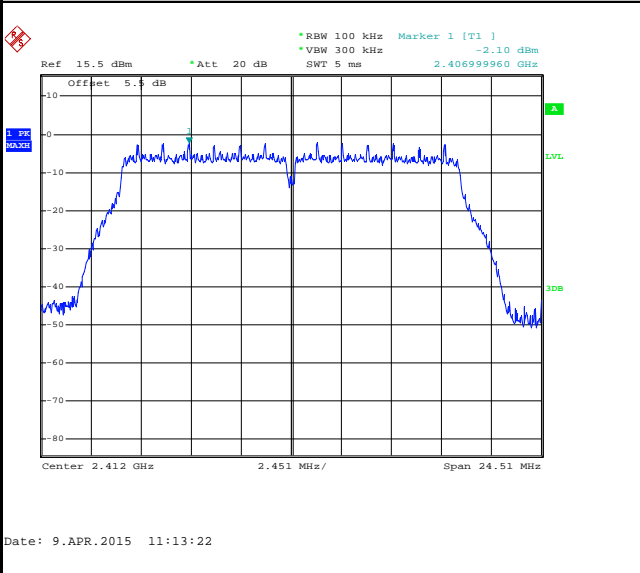

Low Channel Plot

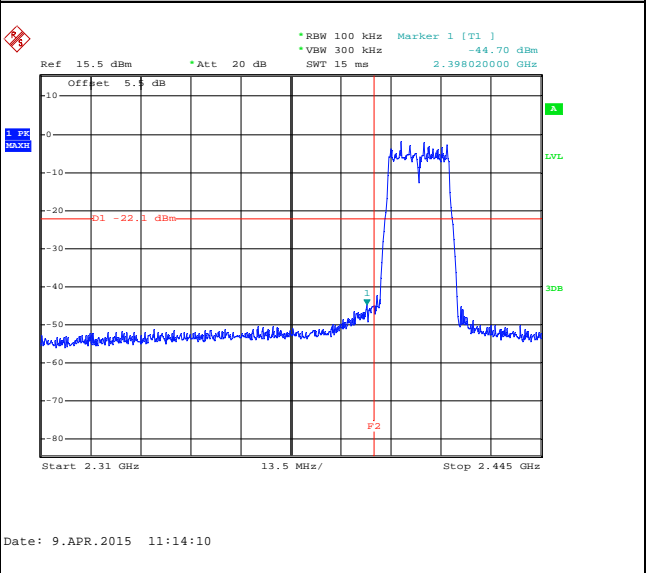

Spurious Emission 30MHz~3GHz

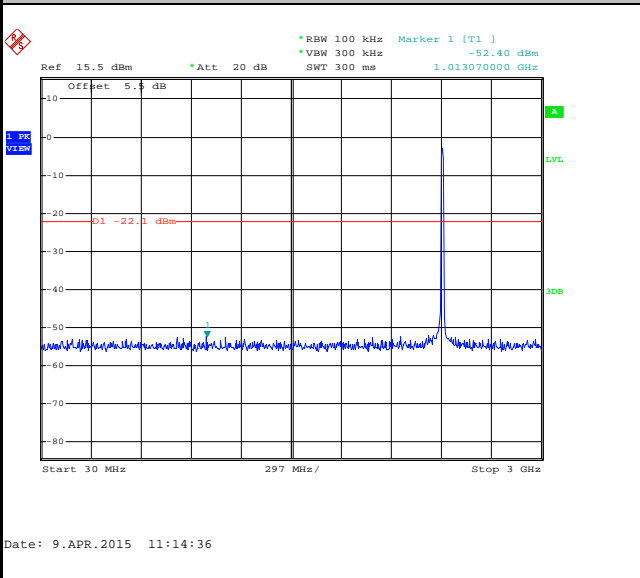

Spurious Emission 2GHz~25GHz

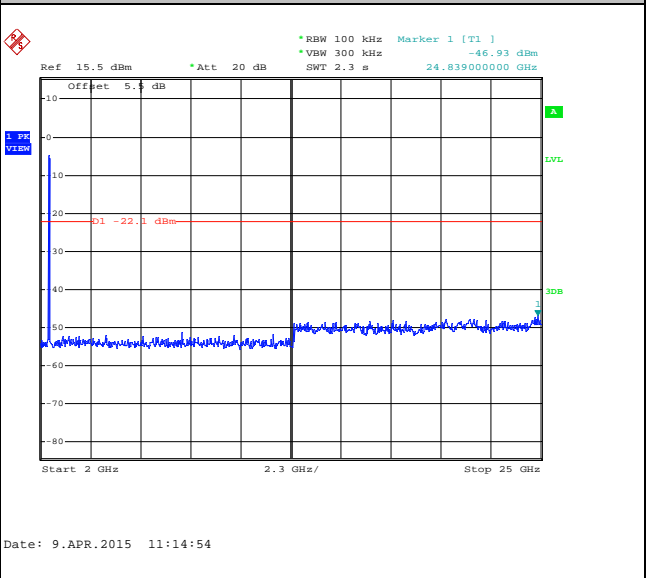



Test Mode :	802.11g	Temperature :	21~25°C
Test Band :	2.4GHz Mid	Relative Humidity :	51~54%
Test Channel :	06	Test Engineer :	Issac Song

WLAN 802.11g Channel 06

100kHz PSD reference Level

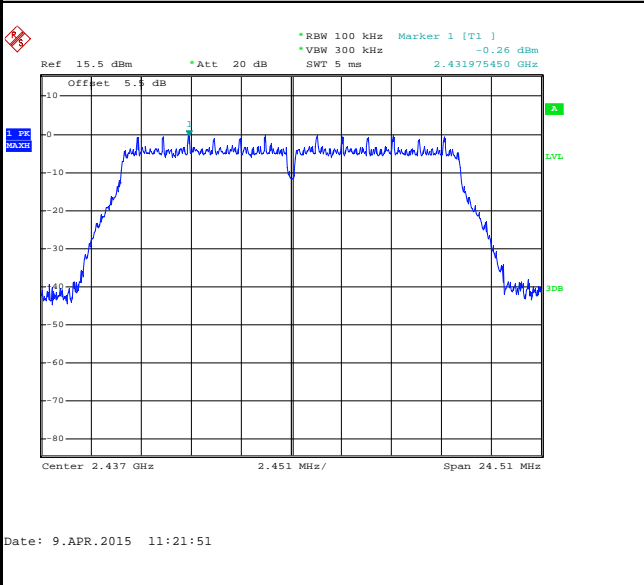

Spurious Emission 30MHz~3GHz

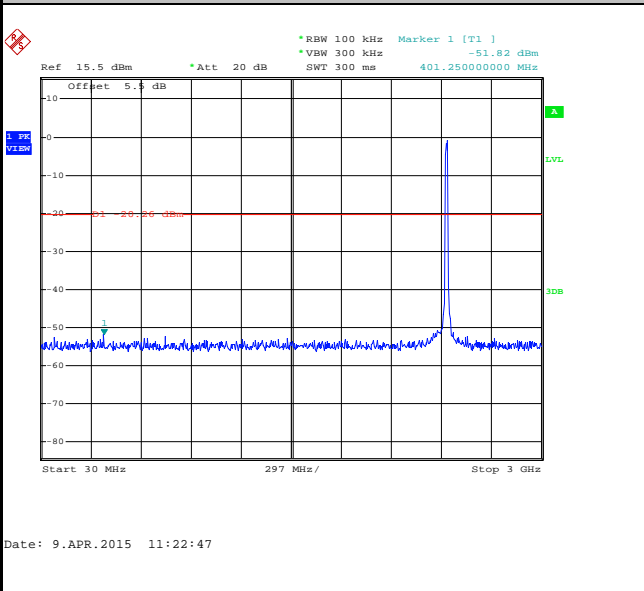

Spurious Emission 2GHz~25GHz

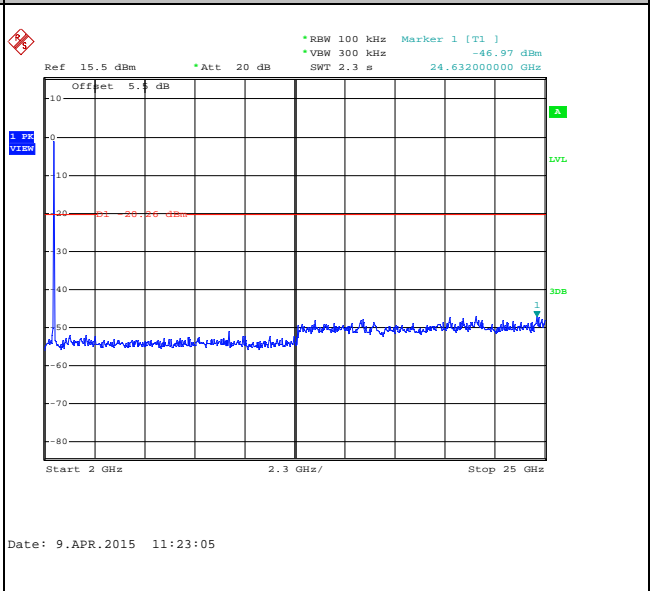



Test Mode :	802.11g	Temperature :	21~25°C
Test Band :	2.4GHz High	Relative Humidity :	51~54%
Test Channel :	11	Test Engineer :	Issac Song

WLAN 802.11g Channel 11

100kHz PSD reference Level

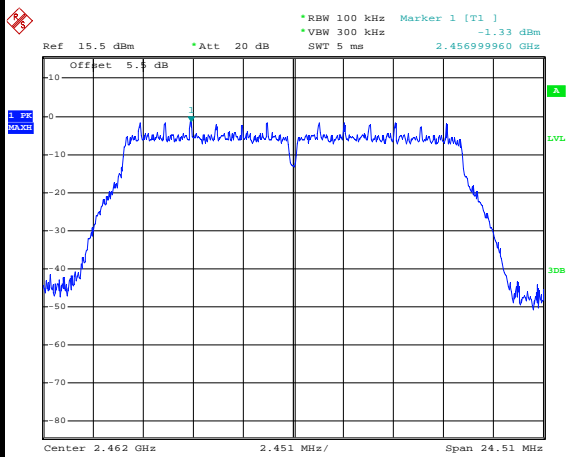

Date: 9.APR.2015 11:26:42

High Channel Plot

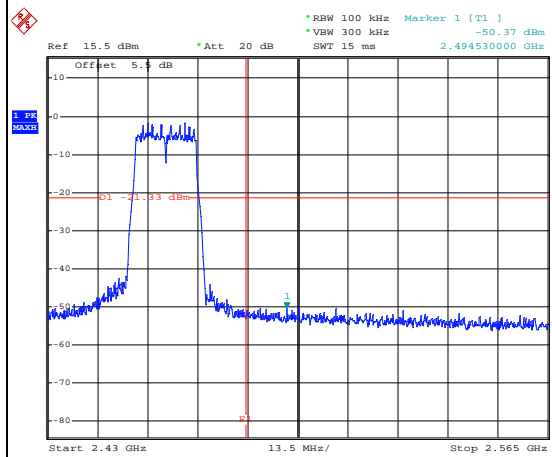

Date: 9.APR.2015 11:27:05

Spurious Emission 30MHz~3GHz

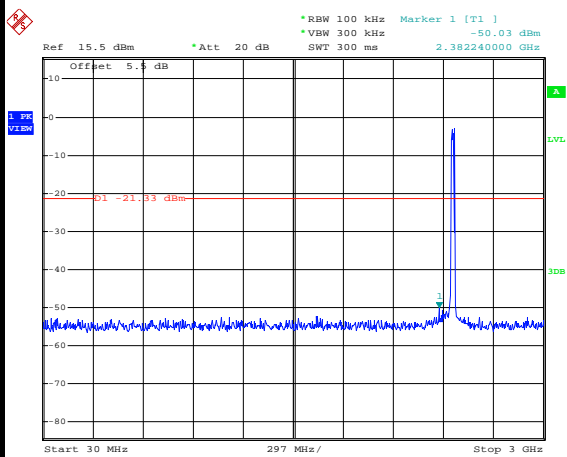

Date: 9.APR.2015 11:27:29

Spurious Emission 2GHz~25GHz

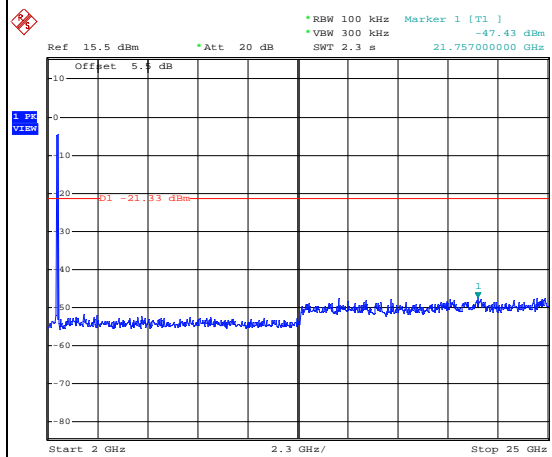

Date: 9.APR.2015 11:27:46



Test Mode :	802.11n HT20	Temperature :	21~25°C
Test Band :	2.4GHz Low	Relative Humidity :	51~54%
Test Channel :	01	Test Engineer :	Issac Song

WLAN 802.11n HT20 Channel 01

100kHz PSD reference Level

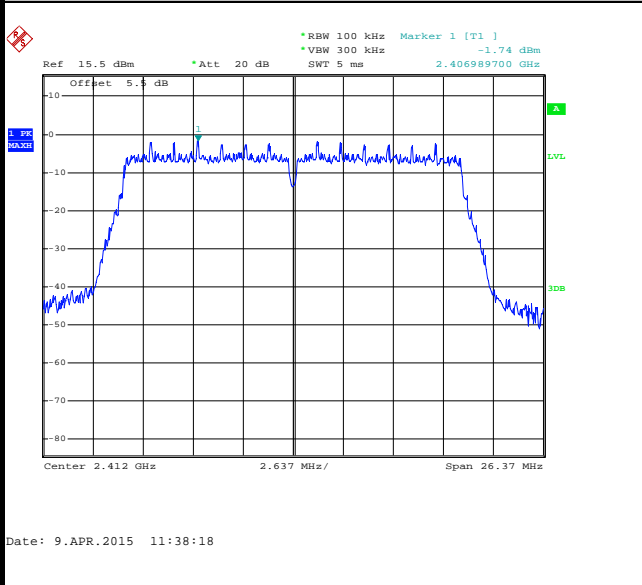

Low Channel Plot

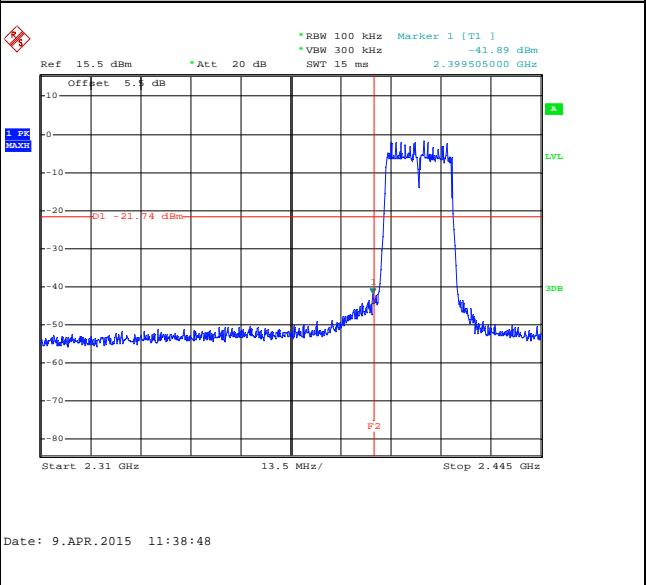

Spurious Emission 30MHz~3GHz

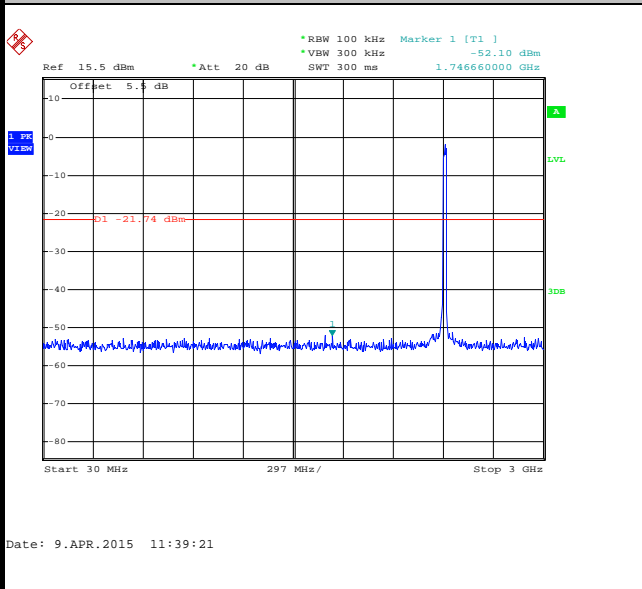

Spurious Emission 2GHz~25GHz

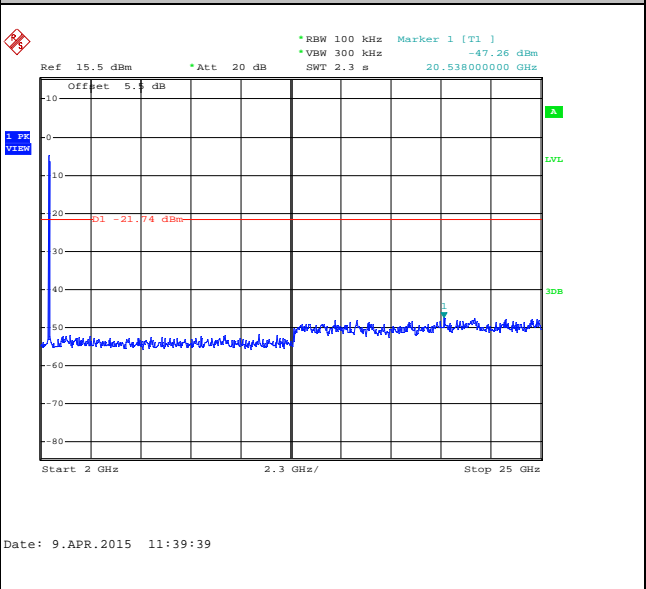



Test Mode :	802.11n HT20	Temperature :	21~25°C
Test Band :	2.4GHz Mid	Relative Humidity :	51~54%
Test Channel :	06	Test Engineer :	Issac Song

WLAN 802.11n HT20 Channel 06

100kHz PSD reference Level

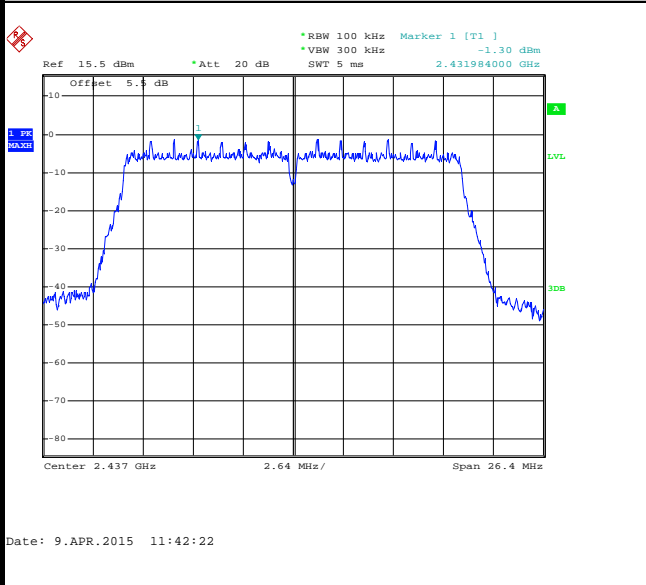

Spurious Emission 30MHz~3GHz

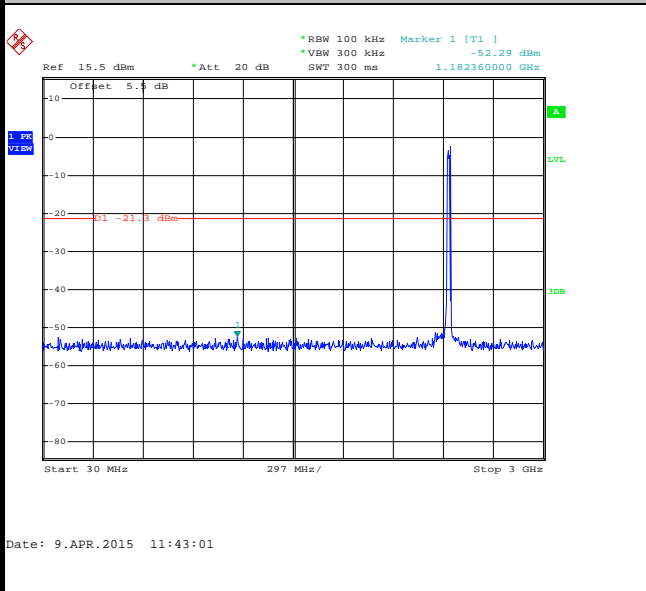

Spurious Emission 2GHz~25GHz

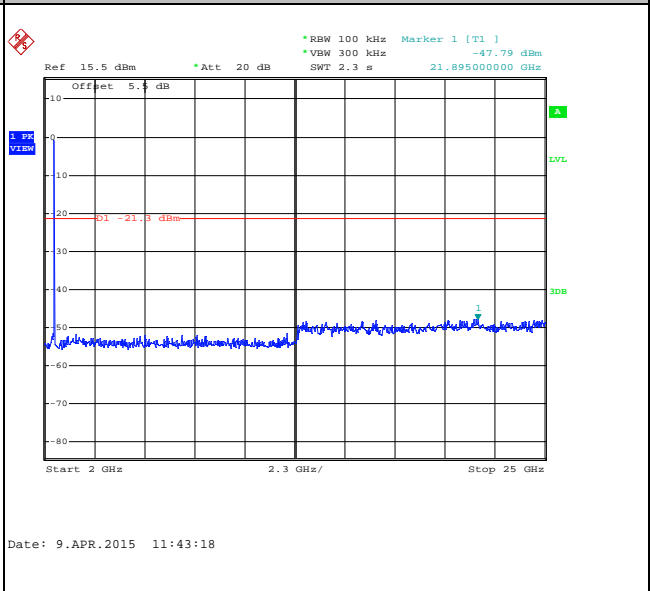



Test Mode :	802.11n HT20	Temperature :	21~25°C
Test Band :	2.4GHz High	Relative Humidity :	51~54%
Test Channel :	11	Test Engineer :	Issac Song

WLAN 802.11n HT20 Channel 11

100kHz PSD reference Level

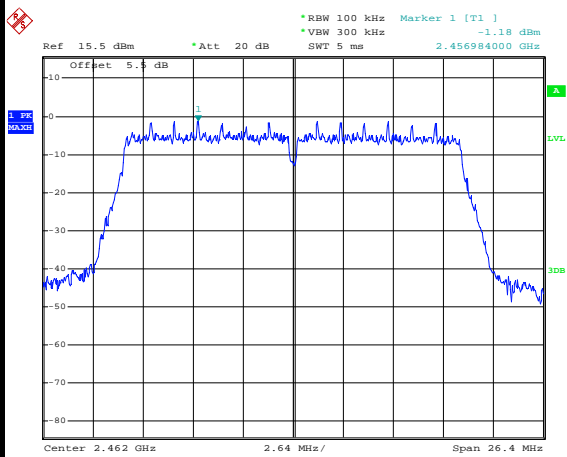

Date: 9.APR.2015 11:46:55

High Channel Plot

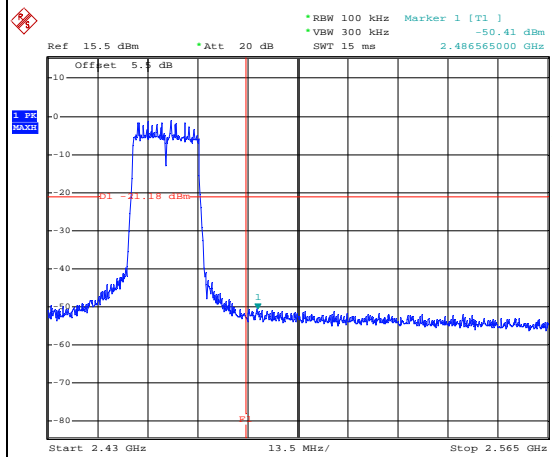

Date: 9.APR.2015 11:47:14

Spurious Emission 30MHz~3GHz

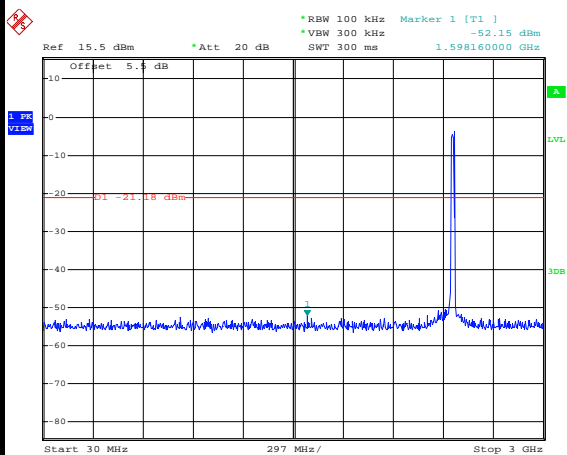

Date: 9.APR.2015 11:49:57

Spurious Emission 2GHz~25GHz

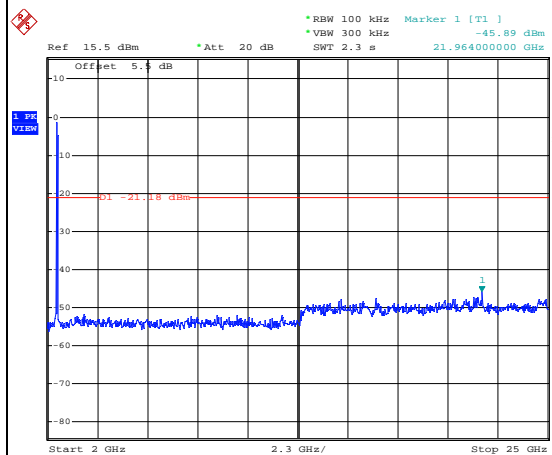

Date: 9.APR.2015 11:50:15



Test Mode :	802.11n HT40	Temperature :	21~25°C
Test Band :	2.4GHz Low	Relative Humidity :	51~54%
Test Channel :	03	Test Engineer :	Issac Song

WLAN 802.11n HT40 Channel 03

100kHz PSD reference Level

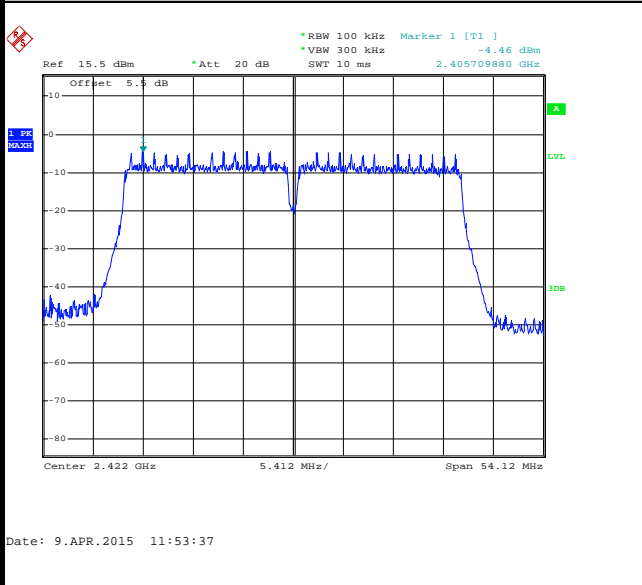

Low Channel Plot

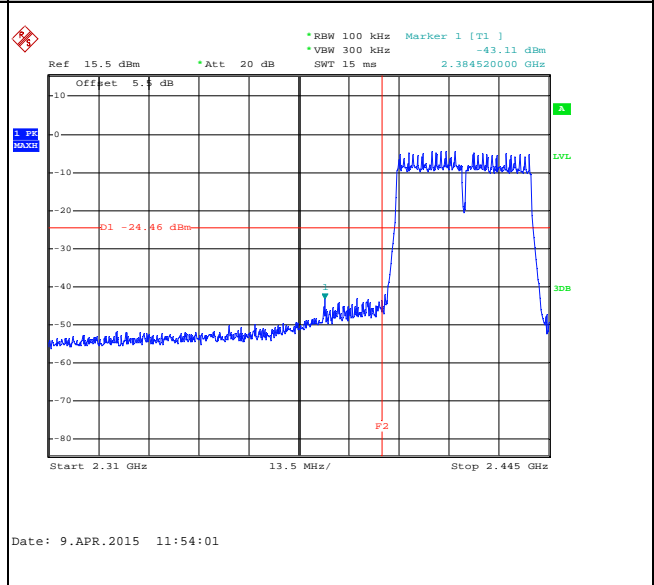

Spurious Emission 30MHz~3GHz

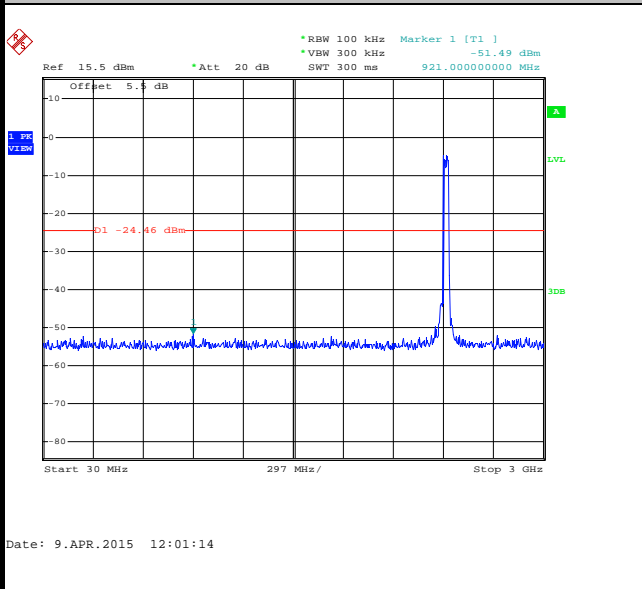

Spurious Emission 2GHz~25GHz

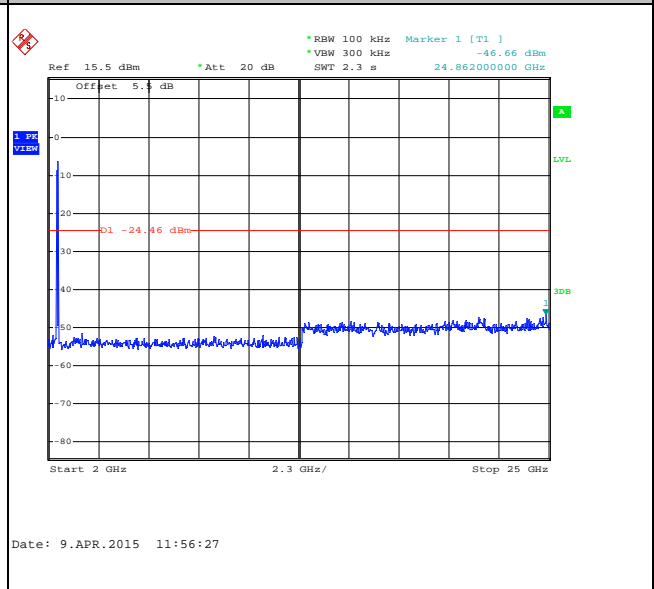



Test Mode :	802.11n HT40	Temperature :	21~25°C
Test Band :	2.4GHz Mid	Relative Humidity :	51~54%
Test Channel :	06	Test Engineer :	Issac Song

WLAN 802.11n HT40 Channel 06

100kHz PSD reference Level

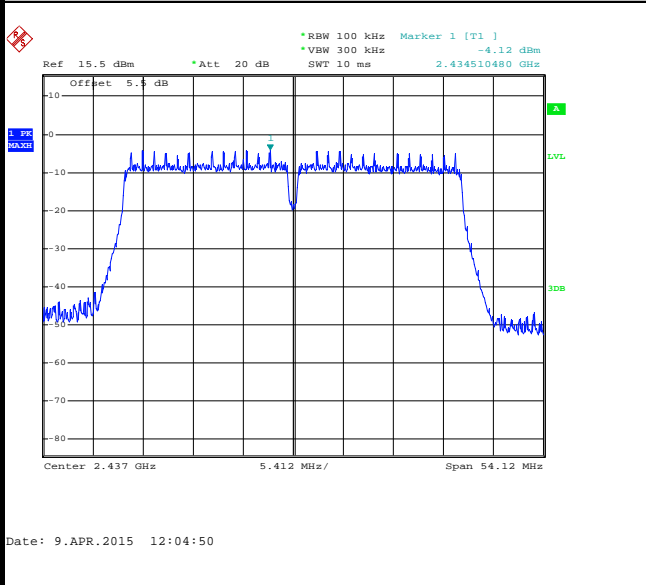

Spurious Emission 30MHz~3GHz

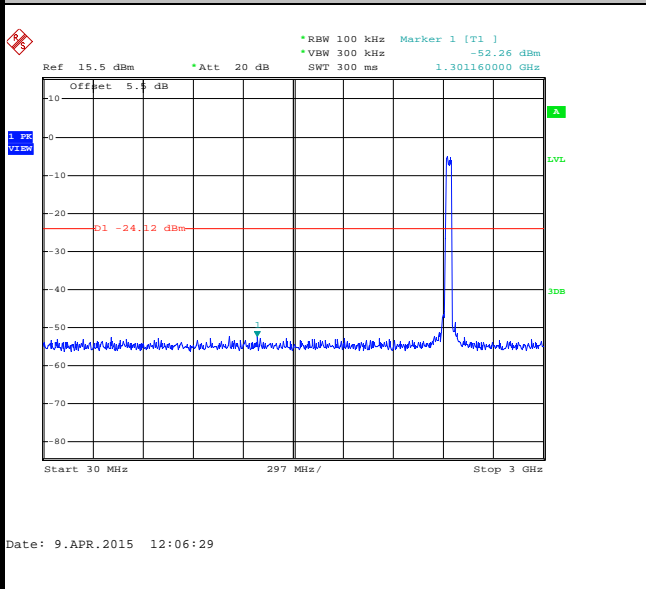

Spurious Emission 2GHz~25GHz

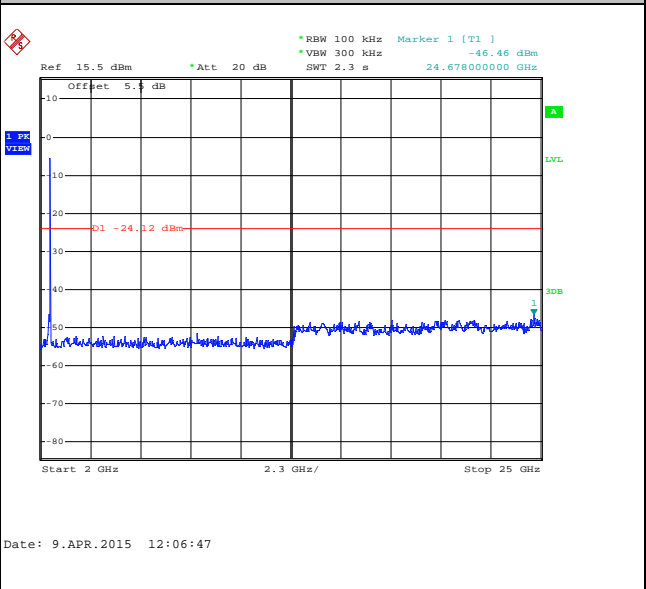



Test Mode :	802.11n HT40	Temperature :	21~25°C
Test Band :	2.4GHz High	Relative Humidity :	51~54%
Test Channel :	09	Test Engineer :	Issac Song

WLAN 802.11n HT40 Channel 09

100kHz PSD reference Level

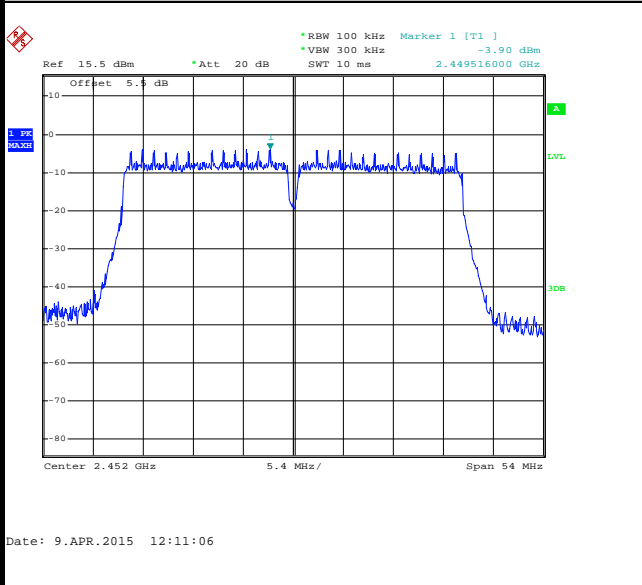

High Channel Plot

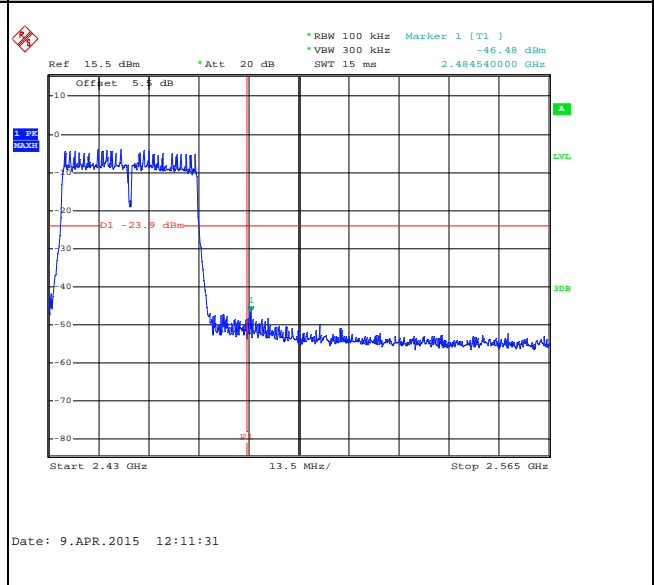

Spurious Emission 30MHz~3GHz

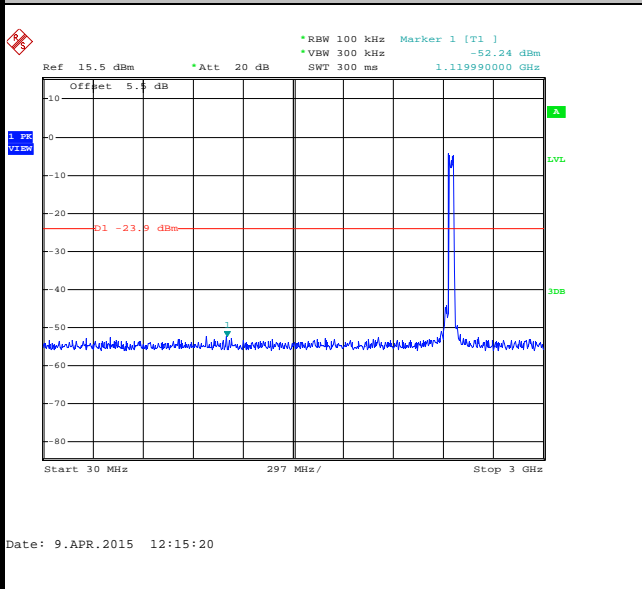

Spurious Emission 2GHz~25GHz

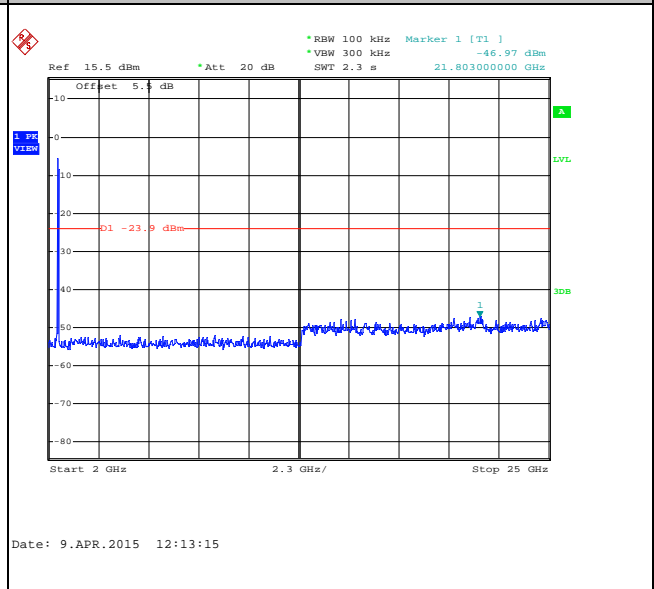



3.5 Radiated Band Edges and Spurious Emission Measurement

3.5.1 Limit of Radiated band edge and Spurious Emission Measurement

In any 100 kHz bandwidth outside the intentional radiator frequency band, all harmonics/spurious must be at least 20 dB below the highest emission level within the authorized band. If the output power of this device was measured by spectrum analyzer, the attenuation under this paragraph shall be 30 dB instead of 20 dB. In addition, radiated emissions which fall in the restricted bands must also comply with the FCC section 15.209 limits as below.

Frequency (MHz)	Field Strength (microvolts/meter)	Measurement Distance (meters)
0.009 – 0.490	2400/F(kHz)	300
0.490 – 1.705	24000/F(kHz)	30
1.705 – 30.0	30	30
30 – 88	100	3
88 – 216	150	3
216 - 960	200	3
Above 960	500	3

3.5.2 Measuring Instruments

The measuring equipment is listed in the section 4 of this test report.



3.5.3 Test Procedures

1. The testing follows FCC KDB Publication No. 558074 D01 DTS Meas. Guidance v03r02.
2. The EUT was arranged to its worst case and then tune the antenna tower (from 1 m to 4 m) and turntable (from 0 degree to 360 degrees) to find the maximum reading. A pre-amp and a high pass filter are used for the test in order to get better signal level.
3. The EUT was placed on a turntable with 0.8 meter for frequency below 1GHz and 1.5 meter for frequency above 1GHz respectively above ground.
4. The EUT was set 3 meters from the interference receiving antenna, which was mounted on the top of a variable height antenna tower.
5. Corrected Reading: Antenna Factor + Cable Loss + Read Level - Preamp Factor = Level
6. For measurement below 1GHz, If the emission level of the EUT measured by the peak detector is 3 dB lower than the applicable limit, the peak emission level will be reported. Otherwise, the emission measurement will be repeated using the quasi-peak detector and reported.
7. Use the following spectrum analyzer settings:
 - (1) Span shall wide enough to fully capture the emission being measured;
 - (2) Set RBW=100 kHz for $f < 1$ GHz; $VBW \geq RBW$; Sweep = auto; Detector function = peak; Trace = max hold;
 - (3) Set RBW = 1 MHz, VBW= 3MHz for $f \geq 1$ GHz for peak measurement.

For average measurement:

 - $VBW = 10$ Hz, when duty cycle is no less than 98 percent.
 - $VBW \geq 1/T$, when duty cycle is less than 98 percent where T is the minimum transmission duration over which the transmitter is on and is transmitting at its maximum power control level for the tested mode of operation.

Band	Duty Cycle(%)	T(ms)	1/T(kHz)	VBW Setting
802.11b	98.13	-	-	10Hz
802.11g	89.10	1.39	0.72	1kHz
2.4GHz 802.11n HT20	88.36	1.31	0.77	1kHz
2.4GHz 802.11n HT40	79.13	0.65	1.53	3kHz

3.5.4 Test Setup

For radiated emissions below 30MHz

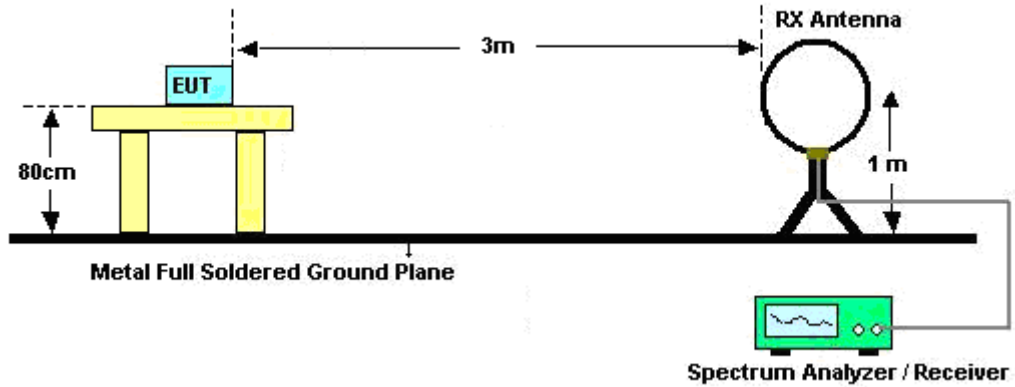

For radiated emissions from 30MHz to 1GHz

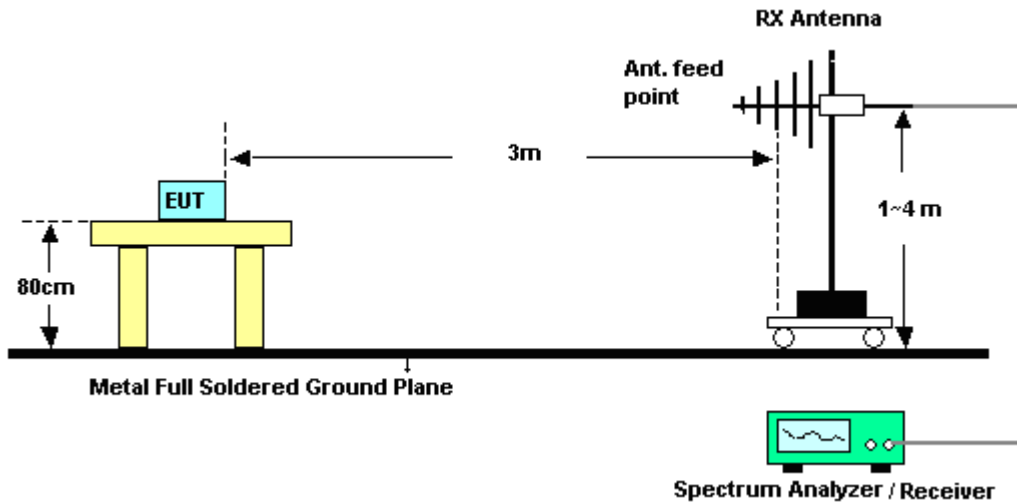

For radiated emissions above 1GHz

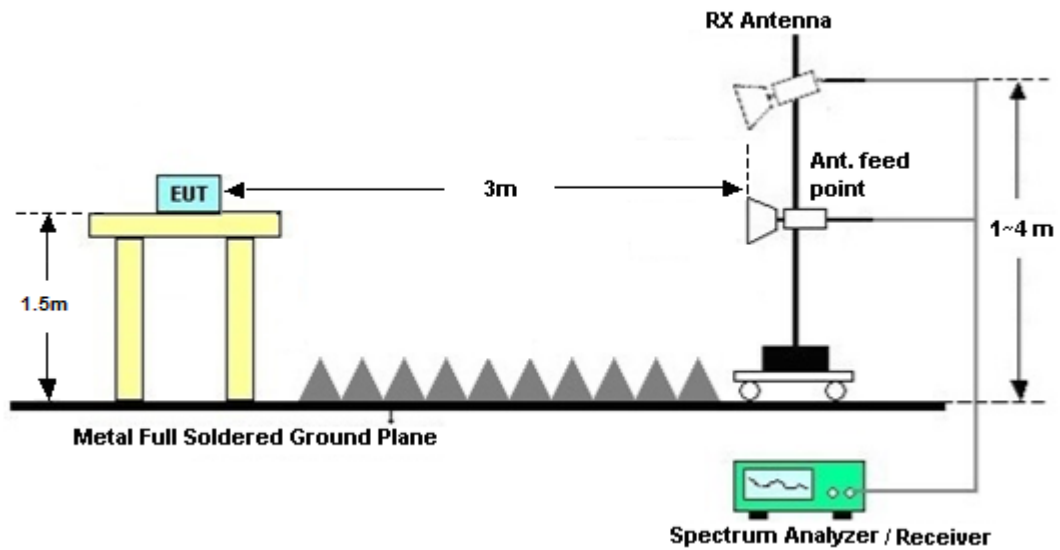

3.5.5 Test Results of Radiated Spurious Emissions (9kHz ~ 30MHz)

The low frequency, which started from 9 kHz to 30MHz, was pre-scanned and the result which was 20dB lower than the limit line per 15.31(o) was not reported.

3.5.6 Test Result of Radiated Spurious at Band Edges

Please refer to Appendix B.

3.5.7 Test Result of Radiated Spurious Emission (30MHz ~ 10th Harmonic)

Please refer to Appendix B.



3.6 AC Conducted Emission Measurement

3.6.1 Limit of AC Conducted Emission

For equipment that is designed to be connected to the public utility (AC) power line, the radio frequency voltage that is conducted back onto the AC power line on any frequency or frequencies within the band 150 kHz to 30 MHz shall not exceed the limits in the following table.

Frequency of Emission (MHz)	Conducted Limit (dB μ V)	
	Quasi-Peak	Average
0.15-0.5	66 to 56*	56 to 46*
0.5-5	56	46
5-30	60	50

*Decreases with the logarithm of the frequency.

3.6.2 Measuring Instruments

The measuring equipment is listed in the section 4 of this test report.

3.6.3 Test Procedures

1. The EUT was placed 0.4 meter from the conducting wall of the shielding room, and it was kept at least 80 centimeters from any other grounded conducting surface.
2. Connect EUT to the power mains through a line impedance stabilization network (LISN).
3. All the support units are connecting to the other LISN.
4. The LISN provides 50 ohm coupling impedance for the measuring instrument.
5. The FCC states that a 50 ohm, 50 microhenry LISN should be used.
6. Both sides of AC line were checked for maximum conducted interference.
7. The frequency range from 150 kHz to 30 MHz was searched.
8. Set the test-receiver system to Peak Detect Function and specified bandwidth (IF bandwidth = 9kHz) with Maximum Hold Mode.

3.6.4 Test Setup

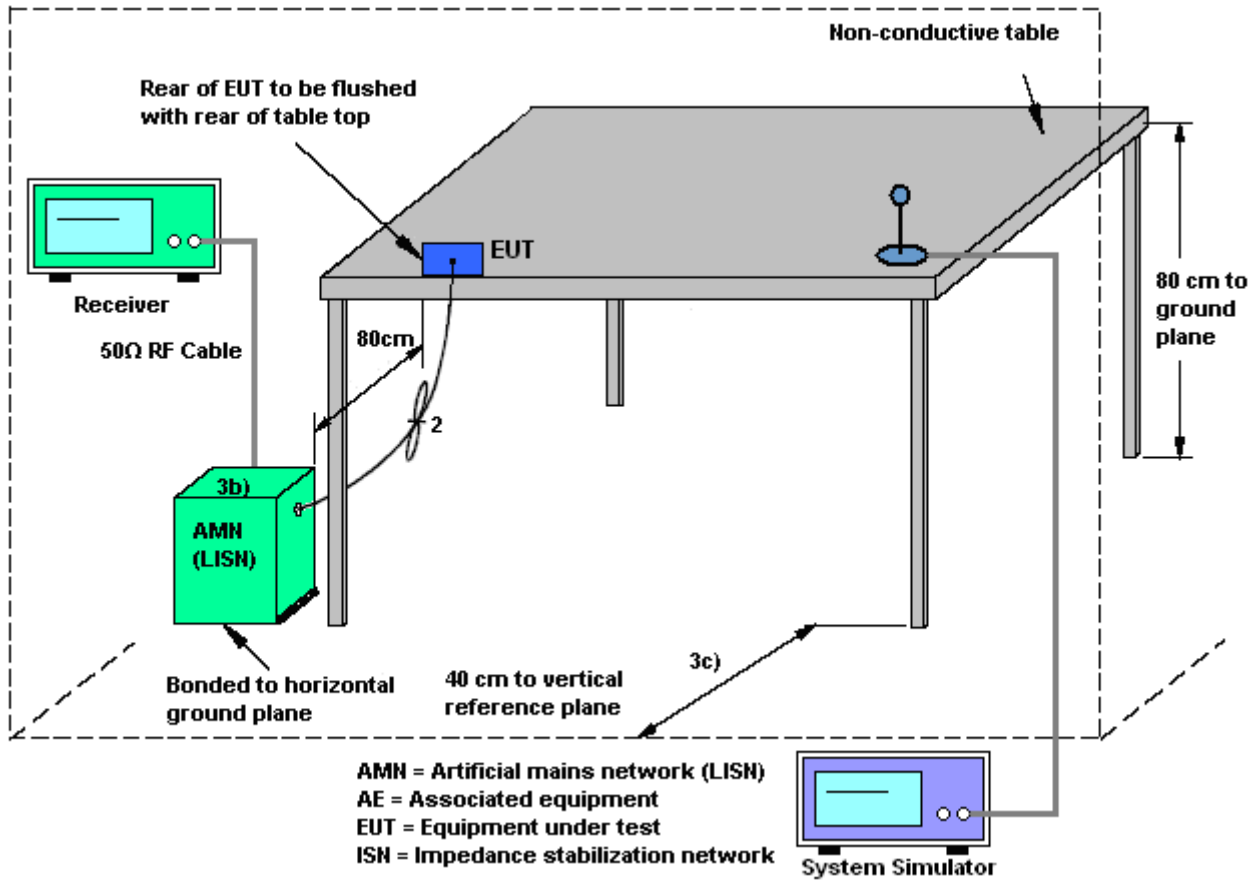



3.6.5 Test Result of AC Conducted Emission

Test Mode :	Mode 1	Temperature :	22~24°C
Test Engineer :	Amos Zhang	Relative Humidity :	37~39%
Test Voltage :	120Vac / 60Hz	Phase :	Line
Function Type :	GSM850 Idle + Bluetooth Link + WLAN Link + Earphone + USB Cable (Charging from Adapter 1) + SIM 1		

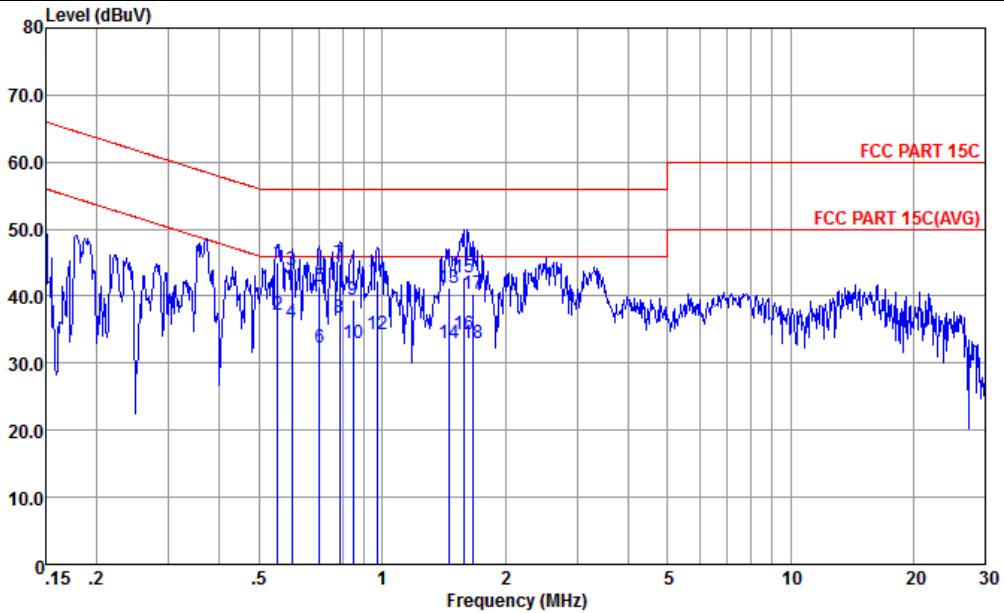

Site : CO01-KS
 Condition : FCC PART 15C LISN-L20140306 LINE

	Freq	Level	Over	Limit	Read	LISN	Cable	Remark
	MHz	dBuV	Limit	Line	Level	Factor	Loss	
			dB	dBuV	dBuV	dB	dB	
1	0.56	45.03	-10.97	56.00	34.20	0.20	10.63	QP
2 *	0.56	37.13	-8.87	46.00	26.30	0.20	10.63	Average
3	0.60	43.93	-12.07	56.00	33.10	0.20	10.63	QP
4	0.60	36.03	-9.97	46.00	25.20	0.20	10.63	Average
5	0.70	41.44	-14.56	56.00	30.60	0.20	10.64	QP
6	0.70	32.34	-13.66	46.00	21.50	0.20	10.64	Average
7	0.79	44.72	-11.28	56.00	33.90	0.17	10.65	QP
8	0.79	36.72	-9.28	46.00	25.90	0.17	10.65	Average
9	0.85	39.39	-16.61	56.00	28.60	0.14	10.65	QP
10	0.85	33.09	-12.91	46.00	22.30	0.14	10.65	Average
11	0.97	42.25	-13.75	56.00	31.50	0.10	10.65	QP
12	0.97	34.35	-11.65	46.00	23.60	0.10	10.65	Average
13	1.46	41.28	-14.72	56.00	30.50	0.10	10.68	QP
14	1.46	33.08	-12.92	46.00	22.30	0.10	10.68	Average
15	1.59	42.89	-13.11	56.00	32.10	0.10	10.69	QP
16	1.59	34.39	-11.61	46.00	23.60	0.10	10.69	Average
17	1.67	40.39	-15.61	56.00	29.60	0.10	10.69	QP
18	1.67	32.89	-13.11	46.00	22.10	0.10	10.69	Average



Test Mode :	Mode 1	Temperature :	22~24°C
Test Engineer :	Amos Zhang	Relative Humidity :	37~39%
Test Voltage :	120Vac / 60Hz	Phase :	Neutral
Function Type :	GSM850 Idle + Bluetooth Link + WLAN Link + Earphone + USB Cable (Charging from Adapter 1) + SIM 1		

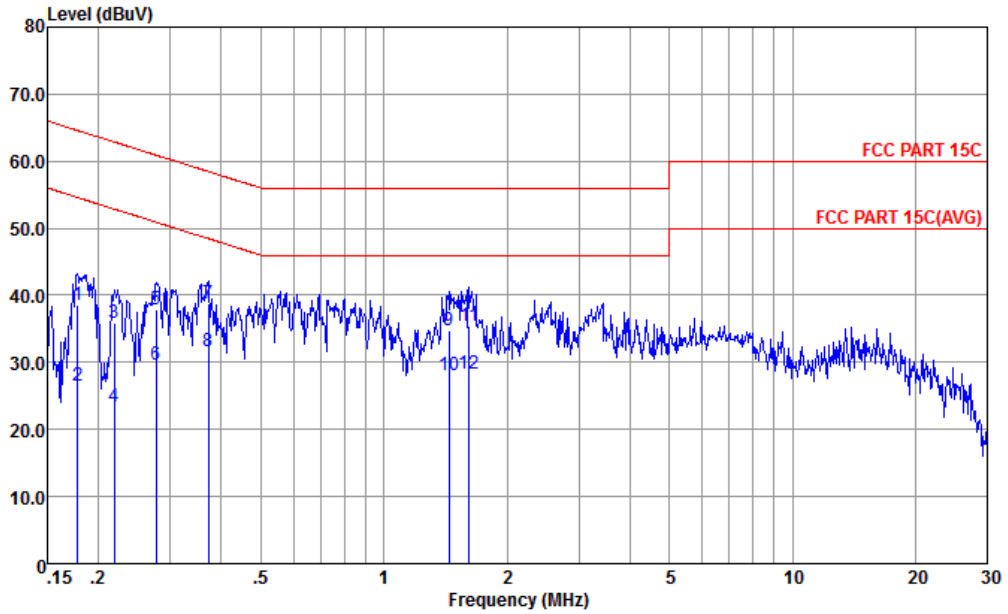

Site : CO01-KS
 Condition : FCC PART 15C LISN-N20140306 NEUTRAL

	Freq	Level	Over	Limit	Read	LISN	Cable	Remark
	MHz	dBuV	Limit	Line	Level	Factor	Loss	
			dB	dBuV	dBuV	dB	dB	
1	0.18	38.58	-26.01	64.59	26.80	1.33	10.45	QP
2	0.18	26.58	-28.01	54.59	14.80	1.33	10.45	Average
3	0.22	35.77	-27.11	62.88	24.30	0.96	10.51	QP
4	0.22	23.37	-29.51	52.88	11.90	0.96	10.51	Average
5	0.28	37.87	-23.03	60.90	26.50	0.82	10.55	QP
6	0.28	29.67	-21.23	50.90	18.30	0.82	10.55	Average
7	0.37	38.67	-19.80	58.47	27.61	0.45	10.61	QP
8 *	0.37	31.57	-16.90	48.47	20.51	0.45	10.61	Average
9	1.44	34.68	-21.32	56.00	23.90	0.10	10.68	QP
10	1.44	27.98	-18.02	46.00	17.20	0.10	10.68	Average
11	1.62	35.39	-20.61	56.00	24.60	0.10	10.69	QP
12	1.62	28.29	-17.71	46.00	17.50	0.10	10.69	Average



3.7 Antenna Requirements

3.7.1 Standard Applicable

If directional gain of transmitting antennas is greater than 6dBi, the power shall be reduced by the same level in dB comparing to gain minus 6dBi. For the fixed point-to-point operation, the power shall be reduced by one dB for every 3 dB that the directional gain of the antenna exceeds 6 dBi. The use of a permanently attached antenna or of an antenna that uses a unique coupling to the intentional radiator shall be considered sufficient to comply with the FCC rule.

3.7.2 Antenna Anti-Replacement Construction

An embedded-in antenna design is used.

3.7.3 Antenna Gain

The antenna peak gain of EUT is less than 6 dBi. Therefore, it is not necessary to reduce maximum peak output power limit.



4 List of Measuring Equipment

Instrument	Manufacturer	Model No.	Serial No.	Characteristics	Calibration Date	Test Date	Due Date	Remark
Spectrum Analyzer	R&S	FSP40	100319	9kHz~40GHz	Oct. 28, 2014	Apr. 09, 2015	Oct. 27, 2015	Conducted (TH01-KS)
Pulse Power Sensor	Anritsu	MA2411B	0917070	30MHz~40GHz	Jan. 23, 2015	Apr. 09, 2015	Jan. 22, 2016	Conducted (TH01-KS)
Power Meter	Anritsu	ML2495A	1005002	50MHz Bandwidth	Jan. 23, 2015	Apr. 09, 2015	Jan. 22, 2016	Conducted (TH01-KS)
EMI Test Receiver	Rohde & Schwarz	ESCI 7	100724	9 kHz~7 GHz	Aug. 30, 2014	Apr. 24, 2015	Aug. 29, 2015	Radiation (03CH07-HY)
Signal Analyzer	Rohde & Schwarz	FSV 30	101749	10Hz ~ 30GHz	Mar. 10, 2015	Apr. 24, 2015	Mar. 09, 2016	Radiation (03CH07-HY)
Loop Antenna	R&S	HFH2-Z2	100315	9 kHz~30 MHz	Jul. 28, 2014	Apr. 24, 2015	Jul. 27, 2015	Radiation (03CH07-HY)
Bilog Antenna	Schaffner	CBL6111C	2726	30MHz ~ 1GHz	Sep. 27, 2014	Apr. 24, 2015	Sep. 26, 2015	Radiation (03CH07-HY)
Double Ridge Horn Antenna	ESCO	3117	75962	1GHz~18GHz	Aug. 19, 2014	Apr. 24, 2015	Aug. 18, 2015	Radiation (03CH07-HY)
SHF-EHF Horn Antenna	SCHWARZBECK	BBHA 9170	BBHA9170251	18GHz~40GHz	Oct. 02, 2014	Apr. 24, 2015	Oct. 01, 2015	Radiation (03CH07-HY)
Preamplifier	COM-POWER	PA-103A	161241	10 MHz ~ 1000MHz	Mar. 12, 2015	Apr. 24, 2015	Mar. 11, 2016	Radiation (03CH07-HY)
Preamplifier	Agilent	8449B	3008A02362	1 GHz~26.5 GHz	Oct. 21, 2014	Apr. 24, 2015	Oct. 20, 2015	Radiation (03CH07-HY)
Turn Table	ChainTek	ChainTek 3000	N/A	0 ~ 360 degree	N/A	Apr. 24, 2015	N/A	Radiation (03CH07-HY)
Antenna Mast	ChainTek	ChainTek 3000	N/A	N/A	N/A	Apr. 24, 2015	N/A	Radiation (03CH07-HY)
EMI Receiver	R&S	ESCI7	100768	9kHz~7GHz;	May 04, 2014	Apr. 07, 2015	May 03, 2015	Conduction (CO01-KS)
AC LISN	MessTec	AN3016	060103	9kHz~30MHz	Oct. 25, 2014	Apr. 07, 2015	Oct. 24, 2015	Conduction (CO01-KS)
AC LISN (for auxiliary equipment)	MessTec	AN3016	060105	9kHz~30MHz	Oct. 25, 2014	Apr. 07, 2015	Oct. 24, 2015	Conduction (CO01-KS)
AC Power Source	Chroma	61602	ABP00000811	AC 0V~300V, 45Hz~1000Hz	Oct. 25, 2014	Apr. 07, 2015	Oct. 24, 2015	Conduction (CO01-KS)



5 Uncertainty of Evaluation

Uncertainty of Conducted Emission Measurement (150kHz ~ 30MHz)

Measuring Uncertainty for a Level of Confidence of 95% ($U = 2Uc(y)$)	2.3 dB
-------------------------------------------------------------------------	--------

Uncertainty of Radiated Emission Measurement (30 MHz ~ 1000 MHz)

Measuring Uncertainty for a Level of Confidence of 95% ($U = 2Uc(y)$)	4.5 dB
-------------------------------------------------------------------------	--------



Appendix A. Conducted Test Results

Test Engineer:	Issac Song	Temperature:	21~25	°C
Test Date:	2015/4/9	Relative Humidity:	51~54	%

TEST RESULTS DATA
6dB and 99% Occupied Bandwidth

2.4GHz Band								
Mod.	Data Rate	NTX	CH.	Freq. (MHz)	99% Occupied BW (MHz)	6dB BW (MHz)	6dB BW Limit (MHz)	Pass/Fail
11b	1Mbps	1	1	2412	12.45	9.04	0.50	Pass
11b	1Mbps	1	6	2437	12.40	9.04	0.50	Pass
11b	1Mbps	1	11	2462	12.45	9.04	0.50	Pass
11g	6Mbps	1	1	2412	17.80	16.34	0.50	Pass
11g	6Mbps	1	6	2437	17.70	16.34	0.50	Pass
11g	6Mbps	1	11	2462	17.80	16.34	0.50	Pass
HT20	MCS0	1	1	2412	18.50	17.58	0.50	Pass
HT20	MCS0	1	6	2437	18.45	17.60	0.50	Pass
HT20	MCS0	1	11	2462	18.50	17.60	0.50	Pass
HT40	MCS0	1	3	2422	36.60	36.08	0.50	Pass
HT40	MCS0	1	6	2437	36.50	36.08	0.50	Pass
HT40	MCS0	1	9	2452	36.60	36.00	0.50	Pass

TEST RESULTS DATA
Peak Power Table

2.4GHz Band										
Mod.	Data Rate	NTX	CH.	Freq. (MHz)	Peak Conducted Power (dBm)	Conducted Power Limit (dBm)	DG (dBi)	EIRP Power (dBm)	EIRP Power Limit (dBm)	Pass /Fail
11b	1Mbps	1	1	2412	18.48	30.00	1.61	20.09	36.00	Pass
11b	1Mbps	1	6	2437	18.66	30.00	1.61	20.27	36.00	Pass
11b	1Mbps	1	11	2462	18.86	30.00	1.61	20.47	36.00	Pass
11g	6Mbps	1	1	2412	19.54	30.00	1.61	21.15	36.00	Pass
11g	6Mbps	1	6	2437	21.73	30.00	1.61	23.34	36.00	Pass
11g	6Mbps	1	11	2462	19.96	30.00	1.61	21.57	36.00	Pass
HT20	MCS0	1	1	2412	19.67	30.00	1.61	21.28	36.00	Pass
HT20	MCS0	1	6	2437	20.15	30.00	1.61	21.76	36.00	Pass
HT20	MCS0	1	11	2462	20.09	30.00	1.61	21.70	36.00	Pass
HT40	MCS0	1	3	2422	19.97	30.00	1.61	21.58	36.00	Pass
HT40	MCS0	1	6	2437	21.09	30.00	1.61	22.70	36.00	Pass
HT40	MCS0	1	9	2452	21.32	30.00	1.61	22.93	36.00	Pass

TEST RESULTS DATA
Average Power Table
(Reporting Only)

2.4GHz Band						
Mod.	Data Rate	N _{TX}	CH.	Freq. (MHz)	Duty Factor (dB)	Average Conducted Power (dBm)
11b	1Mbps	1	1	2412	0.08	15.34
11b	1Mbps	1	6	2437	0.08	15.61
11b	1Mbps	1	11	2462	0.08	15.82
11g	6Mbps	1	1	2412	0.50	9.29
11g	6Mbps	1	6	2437	0.50	10.89
11g	6Mbps	1	11	2462	0.50	9.84
HT20	MCS0	1	1	2412	0.54	9.46
HT20	MCS0	1	6	2437	0.54	9.88
HT20	MCS0	1	11	2462	0.54	9.67
HT40	MCS0	1	3	2422	1.02	8.73
HT40	MCS0	1	6	2437	1.02	9.73
HT40	MCS0	1	9	2452	1.02	10.16

TEST RESULTS DATA
Peak Power Density

2.4GHz Band								
Mod.	Data Rate	NTX	CH.	Freq. (MHz)	Peak PSD (dBm /3kHz)	DG (dBi)	Peak PSD Limit (dBm /3kHz)	Pass/Fail
11b	1Mbps	1	1	2412	-5.28	1.61	8.00	Pass
11b	1Mbps	1	6	2437	-6.95	1.61	8.00	Pass
11b	1Mbps	1	11	2462	-6.99	1.61	8.00	Pass
11g	6Mbps	1	1	2412	-16.25	1.61	8.00	Pass
11g	6Mbps	1	6	2437	-14.13	1.61	8.00	Pass
11g	6Mbps	1	11	2462	-15.74	1.61	8.00	Pass
HT20	MCS0	1	1	2412	-15.07	1.61	8.00	Pass
HT20	MCS0	1	6	2437	-15.51	1.61	8.00	Pass
HT20	MCS0	1	11	2462	-15.20	1.61	8.00	Pass
HT40	MCS0	1	3	2422	-18.83	1.61	8.00	Pass
HT40	MCS0	1	6	2437	-18.01	1.61	8.00	Pass
HT40	MCS0	1	9	2452	-18.74	1.61	8.00	Pass



Appendix B. Radiated Spurious Emission

15C 2.4GHz 2400~2483.5MHz

WIFI 802.11b (Band Edge @ 3m)

WIFI	Note	Frequency (MHz)	Level (dBμV/m)	Over Limit (dB)	Limit Line (dBμV/m)	Read Level (dBμV)	Antenna Factor (dB/m)	Cable Loss (dB)	Preamp Factor (dB)	Ant Pos (cm)	Table Pos (deg)	Peak Avg. (P/A)	Pol. (H/V)
802.11b CH 01 2412MHz		2332.32	59.12	-14.88	74	53.65	32.09	7.6	34.22	111	47	P	H
		2390	45.34	-8.66	54	39.71	32.18	7.75	34.3	111	47	A	H
	*	2413.36	107.29	-	-	101.64	32.2	7.75	34.3	111	47	P	H
	*	2412.69	102.58	-	-	96.93	32.2	7.75	34.3	111	47	A	H
		2313.24	58.81	-15.19	74	53.33	32.07	7.6	34.19	284	80	P	V
		2390	45.55	-8.45	54	39.92	32.18	7.75	34.3	284	80	A	V
	*	2410.69	107.3	-	-	101.65	32.2	7.75	34.3	284	80	P	V
	*	2411.19	102.55	-	-	96.9	32.2	7.75	34.3	284	80	A	V
802.11b CH 06 2437MHz		2377.41	59.23	-14.77	74	53.66	32.16	7.68	34.27	100	43	P	H
		2388.3	45.44	-8.56	54	39.78	32.18	7.75	34.27	100	43	A	H
	*	2435.66	106.69	-	-	100.99	32.22	7.83	34.35	100	43	P	H
	*	2436.24	101.91	-	-	96.21	32.22	7.83	34.35	100	43	A	H
		2488.32	59.06	-14.94	74	53.28	32.3	7.91	34.43	100	43	P	H
		2485.76	45.17	-8.83	54	39.41	32.28	7.91	34.43	100	43	A	H
		2368.68	59.11	-14.89	74	53.54	32.16	7.68	34.27	138	257	P	V
		2374.71	45.02	-8.98	54	39.45	32.16	7.68	34.27	138	257	A	V
	*	2438.49	104.55	-	-	98.83	32.24	7.83	34.35	138	257	P	V
	*	2437.74	99.89	-	-	94.17	32.24	7.83	34.35	138	257	A	V
		2494.6	59.76	-14.24	74	54.03	32.3	7.91	34.48	138	257	P	V
	2490.8	45.19	-8.81	54	39.41	32.3	7.91	34.43	138	257	A	V	



802.11b CH 11 2462MHz	*	2460.71	106.5	-	-	100.72	32.26	7.91	34.39	100	59	P	H
	*	2461.29	101.76	-	-	95.98	32.26	7.91	34.39	100	59	A	H
		2496.84	58.92	-15.08	74	53.19	32.3	7.91	34.48	100	59	P	H
		2487.48	45.51	-8.49	54	39.75	32.28	7.91	34.43	100	59	A	H
	*	2460.79	106.82	-	-	101.04	32.26	7.91	34.39	109	285	P	V
	*	2461.29	102.08	-	-	96.3	32.26	7.91	34.39	109	285	A	V
		2495.32	59.73	-14.27	74	54	32.3	7.91	34.48	109	285	P	V
		2488.24	45.41	-8.59	54	39.63	32.3	7.91	34.43	109	285	A	V
Remark	1. No other spurious found. 2. All results are PASS against Peak and Average limit line.												



15C 2.4GHz 2400~2483.5MHz

WIFI 802.11b (Harmonic @ 3m)

WIFI	Note	Frequency (MHz)	Level (dBμV/m)	Over Limit (dB)	Limit Line (dBμV/m)	Read Level (dBμV)	Antenna Factor (dB/m)	Cable Loss (dB)	Preamp Factor (dB)	Ant Pos (cm)	Table Pos (deg)	Peak Avg. (P/A)	Pol. (H/V)
802.11b CH 01 2412MHz		4824	41.09	-32.91	74	55.31	34.26	11.16	59.64	100	0	P	H
		4824	41.69	-32.31	74	55.91	34.26	11.16	59.64	100	0	P	V
802.11b CH 06 2437MHz		4874	41.24	-32.76	74	55.3	34.3	11.21	59.57	100	0	P	H
		7311	43.64	-30.36	74	51.43	35.6	15.08	58.47	100	0	P	H
		4872	41.54	-32.46	74	55.6	34.3	11.21	59.57	100	0	P	V
		7311	43.24	-30.76	74	51.03	35.6	15.08	58.47	100	0	P	V
802.11b CH 11 2462MHz		4926	43.59	-30.41	74	57.48	34.34	11.27	59.5	100	0	P	H
		7386	44.07	-29.93	74	51.91	35.6	15.14	58.58	100	0	P	H
		4926	42.45	-31.55	74	56.34	34.34	11.27	59.5	100	0	P	V
		7386	46.38	-27.62	74	54.22	35.6	15.14	58.58	100	0	P	V
Remark	1. No other spurious found. 2. All results are PASS against Peak and Average limit line.												



**15C 2.4GHz 2400~2483.5MHz
WIFI 802.11g (Band Edge @ 3m)**

WIFI	Note	Frequency (MHz)	Level (dBμV/m)	Over Limit (dB)	Limit Line (dBμV/m)	Read Level (dBμV)	Antenna Factor (dB/m)	Cable Loss (dB)	Preamp Factor (dB)	Ant Pos (cm)	Table Pos (deg)	Peak Avg. (P/A)	Pol. (H/V)
802.11g CH 01 2412MHz		2357.34	59.96	-14.04	74	54.4	32.13	7.68	34.25	113	56	P	H
		2390	46.85	-7.15	54	41.22	32.18	7.75	34.3	113	56	A	H
	*	2412	103.25	-	-	97.6	32.2	7.75	34.3	113	56	P	H
	*	2412	92.64	-	-	86.99	32.2	7.75	34.3	113	56	A	H
		2338.62	59.2	-14.8	74	53.71	32.11	7.6	34.22	105	204	P	V
		2389.47	46.16	-7.84	54	40.5	32.18	7.75	34.27	105	204	A	V
	*	2412.19	102.37	-	-	96.72	32.2	7.75	34.3	105	204	P	V
	*	2413.11	91.51	-	-	85.86	32.2	7.75	34.3	105	204	A	V
802.11g CH 06 2437MHz		2356.44	60.29	-13.71	74	54.73	32.13	7.68	34.25	100	56	P	H
		2388.75	46.73	-7.27	54	41.07	32.18	7.75	34.27	100	56	A	H
	*	2437.99	105.63	-	-	99.91	32.24	7.83	34.35	100	56	P	H
	*	2437	94.67	-	-	88.95	32.24	7.83	34.35	100	56	A	H
		2486.56	59.83	-14.17	74	54.07	32.28	7.91	34.43	100	56	P	H
		2490.88	46.3	-7.7	54	40.52	32.3	7.91	34.43	100	56	A	H
		2357.34	59.12	-14.88	74	53.56	32.13	7.68	34.25	100	201	P	V
		2356.98	46.16	-7.84	54	40.6	32.13	7.68	34.25	100	201	A	V
	*	2437	102.08	-	-	96.36	32.24	7.83	34.35	100	201	P	V
	*	2437	91.94	-	-	86.22	32.24	7.83	34.35	100	201	A	V
		2492.52	59.79	-14.21	74	54.06	32.3	7.91	34.48	100	201	P	V
		2485.48	46.35	-7.65	54	40.59	32.28	7.91	34.43	100	201	A	V



802.11g CH 11 2462MHz	*	2458.53	102.84	-	-	97.14	32.26	7.83	34.39	100	64	P	H
	*	2458.95	92.21	-	-	86.51	32.26	7.83	34.39	100	64	A	H
		2484.92	59.53	-14.47	74	53.77	32.28	7.91	34.43	100	64	P	H
		2485.04	46.6	-7.4	54	40.84	32.28	7.91	34.43	100	64	A	H
	*	2462	103.31	-	-	97.53	32.26	7.91	34.39	400	294	P	V
	*	2460.71	93.21	-	-	87.43	32.26	7.91	34.39	400	294	A	V
		2487.92	59.25	-14.75	74	53.47	32.3	7.91	34.43	400	294	P	V
		2484.2	46.15	-7.85	54	40.39	32.28	7.91	34.43	400	294	A	V
Remark	1. No other spurious found. 2. All results are PASS against Peak and Average limit line.												



15C 2.4GHz 2400~2483.5MHz

WIFI 802.11g (Harmonic @ 3m)

WIFI	Note	Frequency (MHz)	Level (dBμV/m)	Over Limit (dB)	Limit Line (dBμV/m)	Read Level (dBμV)	Antenna Factor (dB/m)	Cable Loss (dB)	Preamp Factor (dB)	Ant Pos (cm)	Table Pos (deg)	Peak Avg. (P/A)	Pol. (H/V)
802.11g CH 01 2412MHz		4824	41.72	-32.28	74	55.94	34.26	11.16	59.64	100	0	P	H
		4824	42.28	-31.72	74	56.5	34.26	11.16	59.64	100	0	P	V
802.11g CH 06 2437MHz		4872	42.26	-31.74	74	56.32	34.3	11.21	59.57	100	0	P	H
		7311	43.26	-30.74	74	51.05	35.6	15.08	58.47	100	0	P	H
		4874	41.57	-32.43	74	55.63	34.3	11.21	59.57	100	0	P	V
802.11g CH 11 2462MHz		7311	46.17	-27.83	74	53.96	35.6	15.08	58.47	100	0	P	V
		4926	42.46	-31.54	74	56.35	34.34	11.27	59.5	100	0	P	H
		7386	43.98	-30.02	74	51.82	35.6	15.14	58.58	100	0	P	H
		4926	41.74	-32.26	74	55.63	34.34	11.27	59.5	100	0	P	V
		7386	43.99	-30.01	74	51.83	35.6	15.14	58.58	100	0	P	V

Remark	1. No other spurious found. 2. All results are PASS against Peak and Average limit line.
---------------	---------------------------------------------------------------------------------------------



**15C 2.4GHz 2400~2483.5MHz
WIFI 802.11n HT20 (Band Edge @ 3m)**

WIFI	Note	Frequency (MHz)	Level (dBμV/m)	Over Limit (dB)	Limit Line (dBμV/m)	Read Level (dBμV)	Antenna Factor (dB/m)	Cable Loss (dB)	Preamp Factor (dB)	Ant Pos (cm)	Table Pos (deg)	Peak Avg. (P/A)	Pol. (H/V)
802.11n HT20 CH 01 2412MHz		2388.93	60.6	-13.4	74	54.94	32.18	7.75	34.27	112	53	P	H
		2389.2	47.24	-6.76	54	41.58	32.18	7.75	34.27	112	53	A	H
	*	2412	104.98	-	-	99.33	32.2	7.75	34.3	112	53	P	H
	*	2412	94.47	-	-	88.82	32.2	7.75	34.3	112	53	A	H
		2389.11	62.49	-11.51	74	56.83	32.18	7.75	34.27	324	71	P	V
		2389.83	47.99	-6.01	54	42.36	32.18	7.75	34.3	324	71	A	V
	*	2412	103.91	-	-	98.26	32.2	7.75	34.3	324	71	P	V
	*	2412	93.71	-	-	88.06	32.2	7.75	34.3	324	71	A	V
802.11n HT20 CH 06 2437MHz		2381.64	59.76	-14.24	74	54.12	32.16	7.75	34.27	100	54	P	H
		2388.3	46.72	-7.28	54	41.06	32.18	7.75	34.27	100	54	A	H
	*	2437	104.69	-	-	98.97	32.24	7.83	34.35	100	54	P	H
	*	2437	93.78	-	-	88.06	32.24	7.83	34.35	100	54	A	H
		2485.72	59.17	-14.83	74	53.41	32.28	7.91	34.43	100	54	P	H
		2487.8	46.19	-7.81	54	40.41	32.3	7.91	34.43	100	54	A	H
		2330.7	59.14	-14.86	74	53.67	32.09	7.6	34.22	315	106	P	V
		2355.36	45.87	-8.13	54	40.31	32.13	7.68	34.25	315	106	A	V
	*	2437	102.54	-	-	96.82	32.24	7.83	34.35	315	106	P	V
	*	2437	92.39	-	-	86.67	32.24	7.83	34.35	315	106	A	V
		2490.24	59.79	-14.21	74	54.01	32.3	7.91	34.43	315	106	P	V
	2487.68	46.03	-7.97	54	40.25	32.3	7.91	34.43	315	106	A	V	



802.11n HT20 CH 11 2462MHz	*	2462	102.44	-	-	96.66	32.26	7.91	34.39	100	39	P	H
	*	2462	92.25	-	-	86.47	32.26	7.91	34.39	100	39	A	H
		2495.48	59.74	-14.26	74	54.01	32.3	7.91	34.48	100	39	P	H
		2483.92	46.44	-7.56	54	40.68	32.28	7.91	34.43	100	39	A	H
	*	2462	103.26	-	-	97.48	32.26	7.91	34.39	110	293	P	V
	*	2462	91.8	-	-	86.02	32.26	7.91	34.39	110	293	A	V
		2484.6	59.99	-14.01	74	54.23	32.28	7.91	34.43	110	293	P	V
		2487.24	46.36	-7.64	54	40.6	32.28	7.91	34.43	110	293	A	V
Remark	1. No other spurious found. 2. All results are PASS against Peak and Average limit line.												



15C 2.4GHz 2400~2483.5MHz
WIFI 802.11n HT20 (Harmonic @ 3m)

WIFI	Note	Frequency (MHz)	Level (dBμV/m)	Over Limit (dB)	Limit Line (dBμV/m)	Read Level (dBμV)	Antenna Factor (dB/m)	Cable Loss (dB)	Preamp Factor (dB)	Ant Pos (cm)	Table Pos (deg)	Peak Avg. (P/A)	Pol. (H/V)
802.11n HT20 CH 01 2412MHz		4824	42.03	-31.97	74	56.25	34.26	11.16	59.64	100	0	P	H
		4824	41.97	-32.03	74	56.19	34.26	11.16	59.64	100	0	P	V
802.11n HT20 CH 06 2437MHz		4874	41.88	-32.12	74	55.94	34.3	11.21	59.57	100	0	P	H
		7308	43.1	-30.9	74	50.89	35.6	15.08	58.47	100	0	P	H
		4874	41.92	-32.08	74	55.98	34.3	11.21	59.57	100	0	P	V
		7308	43.9	-30.1	74	51.69	35.6	15.08	58.47	100	0	P	V
802.11n HT20 CH 11 2462MHz		4926	42.65	-31.35	74	56.54	34.34	11.27	59.5	100	0	P	H
		7386	43.51	-30.49	74	51.35	35.6	15.14	58.58	100	0	P	H
		4926	42.27	-31.73	74	56.16	34.34	11.27	59.5	100	0	P	V
		7386	43.4	-30.6	74	51.24	35.6	15.14	58.58	100	0	P	V
Remark	1. No other spurious found. 2. All results are PASS against Peak and Average limit line.												



**15C 2.4GHz 2400~2483.5MHz
WIFI 802.11n HT40 (Band Edge @ 3m)**

WIFI	Note	Frequency (MHz)	Level (dBμV/m)	Over Limit (dB)	Limit Line (dBμV/m)	Read Level (dBμV)	Antenna Factor (dB/m)	Cable Loss (dB)	Preamp Factor (dB)	Ant Pos (cm)	Table Pos (deg)	Peak Avg. (P/A)	Pol. (H/V)
802.11n HT40 CH 03 2422MHz		2389.83	63.82	-10.18	74	58.19	32.18	7.75	34.3	114	43	P	H
		2390	47.63	-6.37	54	42	32.18	7.75	34.3	114	43	A	H
	*	2422	99.81	-	-	94.11	32.22	7.83	34.35	114	43	P	H
	*	2422	89.37	-	-	83.67	32.22	7.83	34.35	114	43	A	H
		2492.92	59.63	-14.37	74	53.9	32.3	7.91	34.48	114	43	P	H
		2492.96	46.19	-7.81	54	40.46	32.3	7.91	34.48	114	43	A	H
		2388.57	64.42	-9.58	74	58.76	32.18	7.75	34.27	139	287	P	V
		2389.74	47.73	-6.27	54	42.07	32.18	7.75	34.27	139	287	A	V
	*	2422	97.84	-	-	92.14	32.22	7.83	34.35	139	287	P	V
	*	2422	86.98	-	-	81.28	32.22	7.83	34.35	139	287	A	V
		2486.32	59.1	-14.9	74	53.34	32.28	7.91	34.43	139	287	P	V
		2484.28	46.33	-7.67	54	40.57	32.28	7.91	34.43	139	287	A	V
802.11n HT40 CH 06 2437MHz		2385.78	59.66	-14.34	74	54	32.18	7.75	34.27	100	54	P	H
		2388.21	46.93	-7.07	54	41.27	32.18	7.75	34.27	100	54	A	H
	*	2437	99.37	-	-	93.65	32.24	7.83	34.35	100	54	P	H
	*	2437	89.01	-	-	83.29	32.24	7.83	34.35	100	54	A	H
		2490.76	59.48	-14.52	74	53.7	32.3	7.91	34.43	100	54	P	H
		2483.8	46.41	-7.59	54	40.65	32.28	7.91	34.43	100	54	A	H
		2379.48	58.87	-15.13	74	53.3	32.16	7.68	34.27	326	345	P	V
		2387.22	46.61	-7.39	54	40.95	32.18	7.75	34.27	326	345	A	V
	*	2437	101.85	-	-	96.13	32.24	7.83	34.35	326	345	P	V
	*	2437	91.33	-	-	85.61	32.24	7.83	34.35	326	345	A	V
		2491.96	60.1	-13.9	74	54.37	32.3	7.91	34.48	326	345	P	V
		2488.72	46.5	-7.5	54	40.72	32.3	7.91	34.43	326	345	A	V



802.11n HT40 CH 09 2452MHz		2389.92	59.48	-14.52	74	53.85	32.18	7.75	34.3	100	44	P	H
		2389.29	46.58	-7.42	54	40.92	32.18	7.75	34.27	100	44	A	H
	*	2452	100.85	-	-	95.17	32.24	7.83	34.39	100	44	P	H
	*	2452	90.4	-	-	84.72	32.24	7.83	34.39	100	44	A	H
		2484.96	60.62	-13.38	74	54.86	32.28	7.91	34.43	100	44	P	H
		2484.16	47.24	-6.76	54	41.48	32.28	7.91	34.43	100	44	A	H
		2381.55	59.26	-14.74	74	53.62	32.16	7.75	34.27	366	346	P	V
		2359.23	46.31	-7.69	54	40.75	32.13	7.68	34.25	366	346	A	V
	*	2452	101.29	-	-	95.61	32.24	7.83	34.39	366	346	P	V
	*	2452	90.3	-	-	84.62	32.24	7.83	34.39	366	346	A	V
		2487.84	60.83	-13.17	74	55.05	32.3	7.91	34.43	366	346	P	V
		2485.48	47.43	-6.57	54	41.67	32.28	7.91	34.43	366	346	A	V
Remark	1. No other spurious found. 2. All results are PASS against Peak and Average limit line.												



15C 2.4GHz 2400~2483.5MHz
WIFI 802.11n HT40 (Harmonic @ 3m)

WIFI	Note	Frequency (MHz)	Level (dBμV/m)	Over Limit (dB)	Limit Line (dBμV/m)	Read Level (dBμV)	Antenna Factor (dB/m)	Cable Loss (dB)	Preamp Factor (dB)	Ant Pos (cm)	Table Pos (deg)	Peak Avg. (P/A)	Pol. (H/V)
802.11n HT40 CH 03 2422MHz		4845	41.4	-32.6	74	55.58	34.28	11.16	59.62	100	0	P	H
		7266	43.87	-30.13	74	51.64	35.6	15.06	58.43	100	0	P	H
		4845	42.24	-31.76	74	56.42	34.28	11.16	59.62	100	0	P	V
		7266	45.21	-28.79	74	52.98	35.6	15.06	58.43	100	0	P	V
802.11n HT40 CH 06 2437MHz		4875	42.22	-31.78	74	56.28	34.3	11.21	59.57	100	0	P	H
		7311	43.06	-30.94	74	50.85	35.6	15.08	58.47	100	0	P	H
		4875	40.98	-33.02	74	55.04	34.3	11.21	59.57	100	0	P	V
		7311	43.72	-30.28	74	51.51	35.6	15.08	58.47	100	0	P	V
802.11n HT40 CH 09 2452MHz		4902	41.58	-32.42	74	55.5	34.33	11.27	59.52	100	0	P	H
		7356	43.79	-30.21	74	51.61	35.6	15.11	58.53	100	0	P	H
		4902	41.81	-32.19	74	55.73	34.33	11.27	59.52	100	0	P	V
		7356	43.65	-30.35	74	51.47	35.6	15.11	58.53	100	0	P	V
Remark	1. No other spurious found. 2. All results are PASS against Peak and Average limit line.												



**15C Emission below 1GHz
2.4GHz WIFI 802.11n HT20 (LF)**

WIFI	Note	Frequency (MHz)	Level (dBμV/m)	Over Limit (dB)	Limit Line (dBμV/m)	Read Level (dBμV)	Antenna Factor (dB/m)	Cable Loss (dB)	Preamp Factor (dB)	Ant Pos (cm)	Table Pos (deg)	Peak Avg. (P/A)	Pol. (H/V)
2.4GHz 802.11n HT20 LF		81.57	28.69	-11.31	40	50.58	7.22	2.06	31.17	135	218	P	H
		219	29.02	-16.98	46	48.05	9.29	2.69	31.01	-	-	P	H
		244.92	28.7	-17.3	46	44.84	11.9	2.96	31	-	-	P	H
		461.7	28.09	-17.91	46	37.7	17.42	3.77	30.8	-	-	P	H
		792.1	27.3	-18.7	46	31.08	21.92	4.62	30.32	-	-	P	H
		985.3	29.61	-24.39	54	29.95	24.89	5.03	30.26	-	-	P	H
		49.98	32.47	-7.53	40	53.5	8.4	1.77	31.2	-	-	P	V
		112.35	36.63	-6.87	43.5	54.46	10.96	2.38	31.17	100	154	P	V
		202.53	22.02	-21.48	43.5	41.3	9.13	2.69	31.1	-	-	P	V
		461.7	27.64	-18.36	46	37.25	17.42	3.77	30.8	-	-	P	V
		693.4	27.89	-18.11	46	33.41	20.54	4.35	30.41	-	-	P	V
	932.8	28.84	-17.16	46	30.11	24.3	4.8	30.37	-	-	P	V	
Remark	1. No other spurious found. 2. All results are PASS against limit line.												



Note symbol

*	Fundamental Frequency which can be ignored. However, the level of any unwanted emissions shall not exceed the level of the fundamental frequency per 15.209(c).
!	Test result is over limit line.
P/A	Peak or Average
H/V	Horizontal or Vertical



A calculation example for radiated spurious emission is shown as below:

WIFI Ant. 1+2	Note	Frequency (MHz)	Level (dBμV/m)	Over Limit (dB)	Limit Line (dBμV/m)	Read Level (dBμV)	Antenna Factor (dB/m)	Cable Loss (dB)	Preamp Factor (dB)	Ant Pos (cm)	Table Pos (deg)	Peak Avg. (P/A)	Pol. (H/V)
802.11b CH 01 2412MHz		2390	55.45	-18.55	74	54.51	32.22	4.58	35.86	103	308	P	H
		2390	43.54	-10.46	54	42.6	32.22	4.58	35.86	103	308	A	H

- Level(dBμV/m) =
Antenna Factor(dB/m) + Cable Loss(dB) + Read Level(dBμV) - Preamp Factor(dB)
- Over Limit(dB) = Level(dBμV/m) – Limit Line(dBμV/m)

For Peak Limit @ 2390MHz:

- Level(dBμV/m)
= Antenna Factor(dB/m) + Cable Loss(dB) + Read Level(dBμV) - Preamp Factor(dB)
= 32.22(dB/m) + 4.58(dB) + 54.51(dBμV) – 35.86 (dB)
= 55.45 (dBμV/m)
- Over Limit(dB)
= Level(dBμV/m) – Limit Line(dBμV/m)
= 55.45(dBμV/m) – 74(dBμV/m)
= -18.55(dB)

For Average Limit @ 2390MHz:

- Level(dBμV/m)
= Antenna Factor(dB/m) + Cable Loss(dB) + Read Level(dBμV) - Preamp Factor(dB)
= 32.22(dB/m) + 4.58(dB) + 42.6(dBμV) – 35.86 (dB)
= 43.54 (dBμV/m)
- Over Limit(dB)
= Level(dBμV/m) – Limit Line(dBμV/m)
= 43.54(dBμV/m) – 54(dBμV/m)
= -10.46(dB)

Both peak and average measured complies with the limit line, so test result is “PASS”.