

FCC RF Test Report

APPLICANT : LG Electronics Inc.
EQUIPMENT : Mobile Phone
BRAND NAME : LG
MODEL NAME : LG-X130g, X130g, LGX130g
MARKETING NAME : X130g
FCC ID : ZNFX130G
STANDARD : FCC Part 15 Subpart C §15.247
CLASSIFICATION : (DTS) Digital Transmission System

The product was testing completed on May 15, 2014. We, SPORTON INTERNATIONAL (KUNSHAN) INC., would like to declare that the tested sample has been evaluated in accordance with the test procedures and the testing has shown the tested sample to be in compliance with the applicable technical standards.

The test results in this report apply exclusively to the tested model / sample. Without written approval of SPORTON INTERNATIONAL (KUNSHAN) INC., the test report shall not be reproduced except in full.



Reviewed by: Joseph Lin / Supervisor



Approved by: Jones Tsai / Manager



SPORTON INTERNATIONAL (KUNSHAN) INC.
No. 3-2, PingXiang Road, Kunshan, Jiangsu Province, P.R.C.



TABLE OF CONTENTS

REVISION HISTORY..... 3

SUMMARY OF TEST RESULT 4

1 GENERAL DESCRIPTION 5

 1.1 Applicant 5

 1.2 Manufacturer 5

 1.3 Feature of Equipment Under Test 5

 1.4 Product Specification of Equipment Under Test 5

 1.5 Modification of EUT 6

 1.6 Testing Site 6

 1.7 Applicable Standards 6

2 TEST CONFIGURATION OF EQUIPMENT UNDER TEST 7

 2.1 Carrier Frequency Channel 7

 2.2 Pre-Scanned RF Power 8

 2.3 Test Mode 10

 2.4 Connection Diagram of Test System 11

 2.5 Support Unit used in test configuration and system 12

 2.6 EUT Operation Test Setup 12

 2.7 Measurement Results Explanation Example 12

3 TEST RESULT 13

 3.1 6dB Bandwidth Measurement 13

 3.2 Output Power Measurement 15

 3.3 Power Spectral Density Measurement 18

 3.4 Conducted Band Edges and Spurious Emission Measurement 20

 3.5 Radiated Band Edges and Spurious Emission Measurement 33

 3.6 AC Conducted Emission Measurement 55

 3.7 Antenna Requirements 61

4 LIST OF MEASURING EQUIPMENT 62

5 UNCERTAINTY OF EVALUATION 63

APPENDIX A. SETUP PHOTOGRAPHS

SUMMARY OF TEST RESULT

Report Section	FCC Rule	Description	Limit	Result	Remark
3.1	15.247(a)(2)	6dB Bandwidth	$\geq 0.5\text{MHz}$	Pass	-
3.2	15.247(b)	Power Output Measurement	$\leq 30\text{dBm}$	Pass	-
3.3	15.247(e)	Power Spectral Density	$\leq 8\text{dBm}/3\text{kHz}$	Pass	-
3.4	15.247(d)	Conducted Band Edges	$\leq 20\text{dBc}$	Pass	-
		Conducted Spurious Emission		Pass	-
3.5	15.247(d)	Radiated Band Edges and Radiated Spurious Emission	15.209(a) & 15.247(d)	Pass	Under limit 4.06 dB at 2483.770 MHz
3.6	15.207	AC Conducted Emission	15.207(a)	Pass	Under limit 8.68 dB at 0.410 MHz
3.7	15.203 & 15.247(b)	Antenna Requirement	N/A	Pass	-



1 General Description

1.1 Applicant

LG Electronics Inc.
60-39, Gasan-dong, Gumcheon-gu, Seoul, 153-023, Korea

1.2 Manufacturer

Arima Communication Corp.
6F, No.866, Jhongjheng Rd., Jhonghe Dist., New Taipei City 23586, Taiwan

1.3 Feature of Equipment Under Test

Product Feature	
Equipment	Mobile Phone
Brand Name	LG
Model Name	LG-X130g, X130g, LGX130g
Marketing Name	X130g
FCC ID	ZNFX130G
EUT supports Radios application	GSM/GPRS/EGPRS(Downlink Only)/WCDMA/HSPA/ WLAN2.4GHz 802.11b/g/n HT20/HT40/ Bluetooth v3.0 + EDR/Bluetooth v4.0 LE
HW Version	5502MB-002
EUT Stage	Identical Prototype

Remark: The above EUT's information was declared by manufacturer. Please refer to the specifications or user's manual for more detailed description.

1.4 Product Specification of Equipment Under Test

Product Specification subjective to this standard	
Tx/Rx Channel Frequency Range	2412 MHz ~ 2462 MHz
Maximum (Peak) Output Power to Antenna	802.11b : 18.32 dBm (0.0679 W) 802.11g : 21.46 dBm (0.1400 W) 802.11n HT20 : 20.69 dBm (0.1172 W) 802.11n HT40 : 20.84 dBm (0.1213 W)
Antenna Type	IFA Antenna with gain 1.38 dBi
Type of Modulation	802.11b : DSSS (DBPSK / DQPSK / CCK) 802.11g/n : OFDM (BPSK / QPSK / 16QAM / 64QAM)



1.5 Modification of EUT

No modifications are made to the EUT during all test items.

1.6 Testing Site

Test Site	SPORTON INTERNATIONAL (KUNSHAN) INC.			
Test Site Location	No. 3-2, PingXiang Road, Kunshan, Jiangsu Province, P.R.C. TEL: +86-0512-5790-0158 FAX: +86-0512-5790-0958			
Test Site No.	Sporton Site No.			FCC/IC Registration No.
	TH01-KS	03CH01-KS	CO01-KS	149928/4086E-1

Note: The test site complies with ANSI C63.4 2003 requirement.

1.7 Applicable Standards

According to the specifications of the manufacturer, the EUT must comply with the requirements of the following standards:

- FCC Part 15 Subpart C §15.247
- FCC KDB Publication No. 558074 D01 DTS Meas. Guidance v03r01
- ANSI C63.4-2003

Remark:

1. All test items were verified and recorded according to the standards and without any deviation during the test.
2. This EUT has also been tested and complied with the requirements of FCC Part 15, Subpart B, recorded in a separate test report.



2 Test Configuration of Equipment Under Test

The EUT has been associated with peripherals and configuration operated in a manner tended to maximize its emission characteristics in a typical application. Frequency range investigated: conducted emission (150 kHz to 30 MHz) and radiated emission (9 kHz to the 10th harmonic of the highest fundamental frequency or to 40 GHz, whichever is lower). For radiated measurement, pre-scanned in three orthogonal panels, X, Y, Z. The worst cases (Y plane) were recorded in this report.

The final configuration from all the combinations and the worst-case data rates were investigated by measuring the maximum power across all the data rates and modulation modes under section 2.2.

Based on the worst configuration found above, the RF power setting is set individually to meet FCC compliance limit for the final conducted and radiated tests shown in section 2.3.

2.1 Carrier Frequency Channel

Frequency Band	Channel	Freq. (MHz)	Channel	Freq. (MHz)
2400-2483.5 MHz	1	2412	7	2442
	2	2417	8	2447
	3	2422	9	2452
	4	2427	10	2457
	5	2432	11	2462
	6	2437	-	-



2.2 Pre-Scanned RF Power

Preliminary tests were performed in different data rate and data rate associated with the highest power were chosen for full test shown in the following tables.

2.4GHz 802.11b RF Power (dBm)						
Power vs. Channel			Power vs. Data Rate			
Channel	Frequency (MHz)	Data Rate	Channel	2Mbps	5.5Mbps	11Mbps
		1Mbps				
CH 1	2412	18.09	CH 11	17.71	17.67	17.70
CH 6	2437	18.28				
CH 11	2462	18.32				

2.4GHz 802.11g RF Power (dBm)										
Power vs. Channel			Power vs. Data Rate							
Channel	Frequency (MHz)	Data Rate	Channel	9Mbps	12Mbps	18Mbps	24Mbps	36Mbps	48Mbps	54Mbps
		6Mbps								
CH 1	2412	21.12	CH 11	21.37	21.20	21.23	21.27	21.32	21.45	21.31
CH 6	2437	21.40								
CH 11	2462	21.46								

2.4GHz 802.11n HT20 RF Power (dBm)										
Power vs. Channel			Power vs. MCS Index							
Channel	Frequency (MHz)	MCS Index	Channel	MCS1	MCS2	MCS3	MCS4	MCS5	MCS6	MCS7
		MCS0								
CH 1	2412	20.26	CH 6	20.53	20.42	20.39	20.23	20.02	20.40	20.31
CH 6	2437	20.69								
CH 11	2462	20.68								



2.4GHz 802.11n HT40 RF Power (dBm)										
Power vs. Channel			Power vs. MCS Index							
Channel	Frequency (MHz)	MCS Index	Channel	MCS1	MCS2	MCS3	MCS4	MCS5	MCS6	MCS7
		MCS0								
CH 03	2422 MHz	20.62	CH 09	20.81	20.03	19.71	19.05	19.18	18.95	19.42
CH 06	2437 MHz	20.78								
CH 09	2452 MHz	20.84								



2.3 Test Mode

Final results of test modes, data rates and test channels are shown as following table.

Test Cases				
	Test Items	Mode	Data Rate	Test Channel
Conducted TCs	6dB BW Power Spectral Density	802.11b	1 Mbps	1/6/11
		802.11g	6 Mbps	1/6/11
		802.11n HT20	MCS0	1/6/11
		802.11n HT40	MCS0	3/6/9
	Output Power	802.11b	1 Mbps	1/6/11
		802.11g	6 Mbps	1/6/11
		802.11n HT20	MCS0	1/6/11
		802.11n HT40	MCS0	3/6/9
	Conducted Band Edge	802.11b	1 Mbps	1/11
		802.11g	6 Mbps	1/11
		802.11n HT20	MCS0	1/11
		802.11n HT40	MCS0	3/9
	Conducted Spurious Emission	802.11b	1 Mbps	1/6/11
		802.11g	6 Mbps	1/6/11
		802.11n HT20	MCS0	1/6/11
		802.11n HT40	MCS0	3/6/9
Radiated TCs	Radiated Band Edge	802.11b	1 Mbps	1/11
		802.11g	6 Mbps	1/11
		802.11n HT20	MCS0	1/11
		802.11n HT40	MCS0	3/9
	Radiated Spurious Emission	802.11b	1 Mbps	1/6/11
		802.11g	6 Mbps	1/6/11
		802.11n HT20	MCS0	1/6/11
		802.11n HT40	MCS0	3/6/9
AC Conducted Emission	Mode 1 : GSM850 Idle + Bluetooth Link + WLAN Link + USB Cable (Charging from Adapter) + Earphone			
Remark: For radiated test cases, the tests were performed with adapter, earphone, and USB cable.				

2.4 Connection Diagram of Test System

<WLAN Tx Mode>

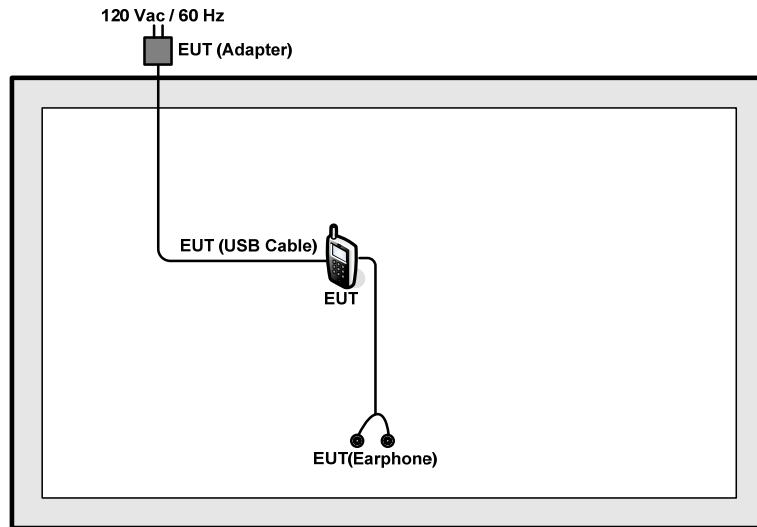

<AC Conducted Emission Mode>

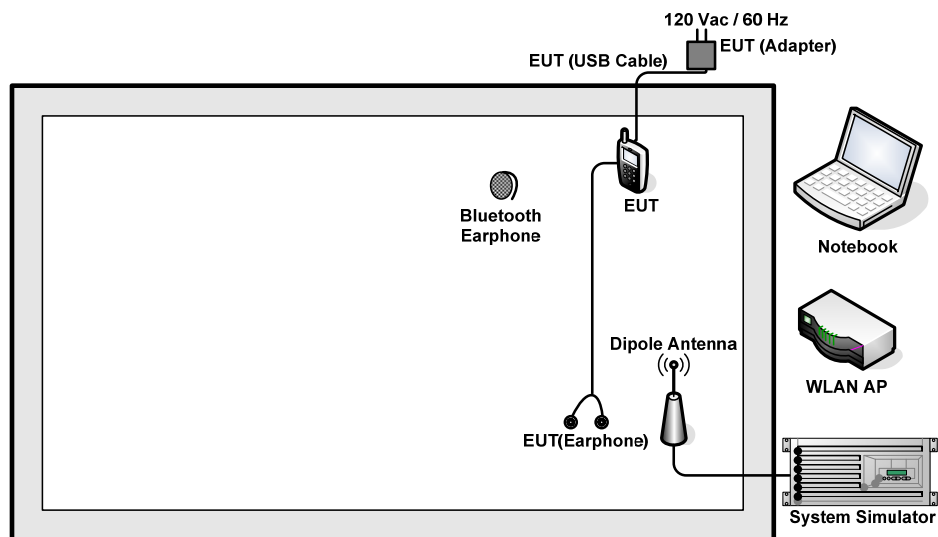

2.5 Support Unit used in test configuration and system

Item	Equipment	Trade Name	Model Name	FCC ID	Data Cable	Power Cord
1.	System Simulator	R&S	CMU 200	N/A	N/A	Unshielded, 1.8 m
2.	WLAN AP	D-Link	DIR-855	KA2DIR855A2	N/A	Unshielded, 1.8 m
3.	Notebook	Lenovo	G480	PRC4	N/A	AC I/P: Unshielded, 1.8 m DC O/P: Shielded, 1.8 m
4.	Bluetooth Earphone	Nokia	BH-106	QTLBH-106	N/A	N/A

2.6 EUT Operation Test Setup

For WLAN RF test items, an engineering test program was provided and enabled to make EUT continuously transmit/receive.

For AC power line conducted emissions, the EUT was set to connect with the WLAN AP under large package sizes transmission.

2.7 Measurement Results Explanation Example

For all conducted test items:

The offset level is set in the spectrum analyzer to compensate the RF cable loss and attenuator factor between EUT conducted output port and spectrum analyzer. With the offset compensation, the spectrum analyzer reading level is exactly the EUT RF output level.

Example:

The spectrum analyzer offset is derived from RF cable loss and attenuator factor.

Offset = RF cable loss + attenuator factor.

Following shows an offset computation example with cable loss 6.5 dB and 10dB attenuator.

$$\begin{aligned}
 \text{Offset(dB)} &= \text{RF cable loss(dB)} + \text{attenuator factor(dB)} \\
 &= 6.5 + 10 = 16.5 \text{ (dB)}
 \end{aligned}$$

3 Test Result

3.1 6dB Bandwidth Measurement

3.1.1 Limit of 6dB Bandwidth

The minimum 6 dB bandwidth shall be at least 500 kHz.

3.1.2 Measuring Instruments

The measuring equipment is listed in the section 4 of this test report.

3.1.3 Test Procedures

1. The testing follows FCC KDB Publication No. 558074 DTS D01 Meas. Guidance v03r01.
2. The RF output of EUT was connected to the spectrum analyzer by RF cable and attenuator. The path loss was compensated to the results for each measurement.
3. Set to the maximum power setting and enable the EUT transmit continuously.
4. Make the measurement with the spectrum analyzer's resolution bandwidth (RBW) = 100 kHz. Set the Video bandwidth (VBW) = 300 kHz. In order to make an accurate measurement. The 6 dB bandwidth must be greater than 500 kHz.
5. Measure and record the results in the test report.

3.1.4 Test Setup

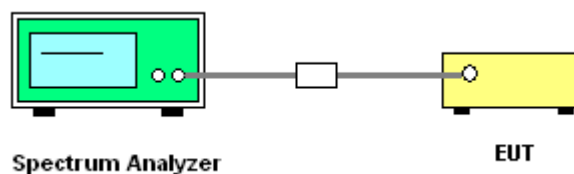



3.1.5 Test Result of 6dB Bandwidth

Test Band :	2.4GHz	Temperature :	23~24°C
Test Engineer :	Adonis Li	Relative Humidity :	47~48%

Mod.	Data Rate	N _{TX}	Channel	Freq. (MHz)	6dB Bandwidth (MHz)	6dB Bandwidth Min. Limit (MHz)	Pass/Fail
11b	1Mbps	1	1	2412	9.50	0.5	Pass
11b	1Mbps	1	6	2437	10.02	0.5	Pass
11b	1Mbps	1	11	2462	10.00	0.5	Pass
11g	6Mbps	1	1	2412	15.34	0.5	Pass
11g	6Mbps	1	6	2437	15.14	0.5	Pass
11g	6Mbps	1	11	2462	15.42	0.5	Pass
HT20	MCS0	1	1	2412	17.58	0.5	Pass
HT20	MCS0	1	6	2437	17.58	0.5	Pass
HT20	MCS0	1	11	2462	17.60	0.5	Pass
HT40	MCS0	1	3	2422	36.00	0.5	Pass
HT40	MCS0	1	6	2437	35.88	0.5	Pass
HT40	MCS0	1	9	2452	36.04	0.5	Pass

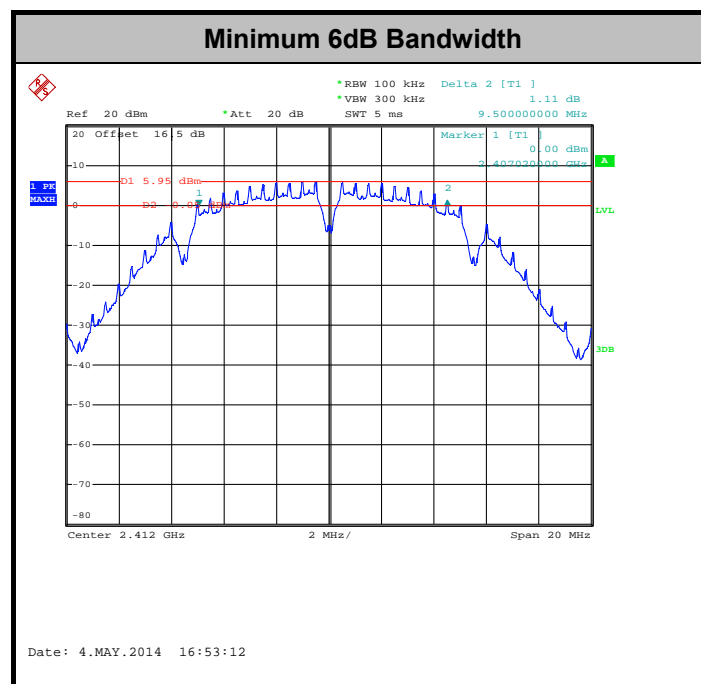

3.2 Output Power Measurement

3.2.1 Limit of Output Power

For systems using digital modulation in the 2400-2483.5MHz, the limit for peak output power is 30dBm. If transmitting Antenna of directional gain greater than 6dBi are used the peak output power from the intentional radiator shall be reduced below the above stated value by the amount in dB that the directional gain of the Antenna exceeds 6 dBi. In case of point-to-point operation, the limit has to be reduced by 1dB for every 3dB that the directional gain of the Antenna exceeds 6dBi.

3.2.2 Measuring Instruments

The measuring equipment is listed in the section 4 of this test report.

3.2.3 Test Procedures

1. The testing follows the Measurement Procedure of FCC KDB No. 558074 DTS D01 Meas. Guidance v03r01.
2. The RF output of EUT was connected to the power meter by RF cable and attenuator. The path loss was compensated to the results for each measurement.
3. Set to the maximum power setting and enable the EUT transmit continuously.
4. Measure the conducted output power and record the results in the test report.

3.2.4 Test Setup

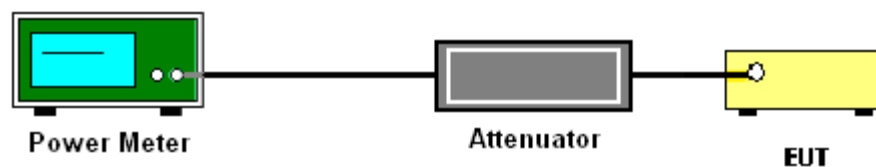



3.2.5 Test Result of Peak Output Power

Test Mode :	2.4GHz	Temperature :	23~24°C
Test Engineer :	Adonis Li	Relative Humidity :	47~48%

Mod.	Data Rate	N _{TX}	Channel	Freq. (MHz)	RF Output Power (dBm)	Power Limit (dBm)	DG (dBi)	Pass/Fail
11b	1Mbps	1	1	2412	18.09	30	1.38	Pass
11b	1Mbps	1	6	2437	18.28	30	1.38	Pass
11b	1Mbps	1	11	2462	18.32	30	1.38	Pass
11g	6Mbps	1	1	2412	21.12	30	1.38	Pass
11g	6Mbps	1	6	2437	21.40	30	1.38	Pass
11g	6Mbps	1	11	2462	21.46	30	1.38	Pass
HT20	MCS0	1	1	2412	20.26	30	1.38	Pass
HT20	MCS0	1	6	2437	20.69	30	1.38	Pass
HT20	MCS0	1	11	2462	20.68	30	1.38	Pass
HT40	MCS0	1	3	2422	20.62	30	1.38	Pass
HT40	MCS0	1	6	2437	20.78	30	1.38	Pass
HT40	MCS0	1	9	2452	20.84	30	1.38	Pass

Note: Measured power (dBm) has offset with cable loss.



3.2.6 Test Result of Average output Power (Reporting Only)

Test Mode :	2.4GHz	Temperature :	23~24°C
Test Engineer :	Adonis Li	Relative Humidity :	47~48%

Mod.	Data Rate	N _{TX}	Channel	Freq. (MHz)	Duty Factor (dB)	Average Output Power (dBm)	Power Limit (dBm)	DG (dBi)	Pass/Fail
11b	1Mbps	1	1	2412	0.08	15.75	30	1.38	Pass
11b	1Mbps	1	6	2437	0.08	15.69	30	1.38	Pass
11b	1Mbps	1	11	2462	0.08	15.77	30	1.38	Pass
11g	6Mbps	1	1	2412	0.53	11.79	30	1.38	Pass
11g	6Mbps	1	6	2437	0.53	11.93	30	1.38	Pass
11g	6Mbps	1	11	2462	0.53	12.42	30	1.38	Pass
HT20	MCS0	1	1	2412	0.51	9.72	30	1.38	Pass
HT20	MCS0	1	6	2437	0.51	10.10	30	1.38	Pass
HT20	MCS0	1	11	2462	0.51	9.94	30	1.38	Pass
HT40	MCS0	1	3	2422	1.01	8.78	30	1.38	Pass
HT40	MCS0	1	6	2437	1.01	8.97	30	1.38	Pass
HT40	MCS0	1	9	2452	1.01	9.40	30	1.38	Pass

Note: Measured power (dBm) has offset with cable loss and duty factor.

3.3 Power Spectral Density Measurement

3.3.1 Limit of Power Spectral Density

The peak power spectral density shall not be greater than 8dBm in any 3kHz band at any time interval of continuous transmission.

3.3.2 Measuring Instruments

The measuring equipment is listed in the section 4 of this test report.

3.3.3 Test Procedures

1. The testing follows Measurement Procedure 10.2 Method PKPSD of FCC KDB Publication No. 558074 D01 DTS Meas. Guidance v03r01
2. The RF output of EUT was connected to the spectrum analyzer by RF cable and attenuator. The path loss was compensated to the results for each measurement.
3. Set to the maximum power setting and enable the EUT transmit continuously.
4. Make the measurement with the spectrum analyzer's resolution bandwidth (RBW) = 3 kHz. Video bandwidth VBW = 10 kHz in order to make an accurate measurement, set the span to 1.5 times DTS Channel Bandwidth. (6dB BW)
5. Detector = peak, Sweep time = auto couple, Trace mode = max hold, Allow trace to fully stabilize. Use the peak marker function to determine the maximum power level.
6. Measure and record the results in the test report.

3.3.4 Test Setup

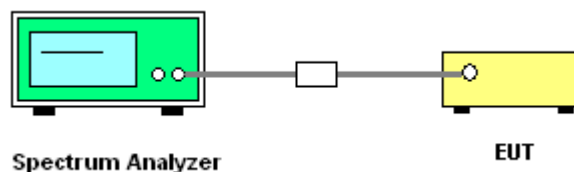



3.3.5 Test Result of Power Spectral Density

Test Mode :	2.4GHz	Temperature :	23~24°C
Test Engineer :	Adonis Li	Relative Humidity :	47~48%

Mod.	Data Rate	N _{TX}	Channel	Freq. (MHz)	Peak Power Density (dBm/3kHz)	Max. Limits (dBm/3kHz)	DG (dBi)	Pass/Fail
11b	1Mbps	1	1	2412	-8.15	8	1.38	Pass
11b	1Mbps	1	6	2437	-7.86	8	1.38	Pass
11b	1Mbps	1	11	2462	-7.47	8	1.38	Pass
11g	6Mbps	1	1	2412	-13.31	8	1.38	Pass
11g	6Mbps	1	6	2437	-11.78	8	1.38	Pass
11g	6Mbps	1	11	2462	-12.50	8	1.38	Pass
HT20	MCS0	1	1	2412	-14.67	8	1.38	Pass
HT20	MCS0	1	6	2437	-14.11	8	1.38	Pass
HT20	MCS0	1	11	2462	-14.61	8	1.38	Pass
HT40	MCS0	1	3	2422	-19.47	8	1.38	Pass
HT40	MCS0	1	6	2437	-19.59	8	1.38	Pass
HT40	MCS0	1	9	2452	-18.90	8	1.38	Pass

Note: Measured power density (dBm) has offset with cable loss.

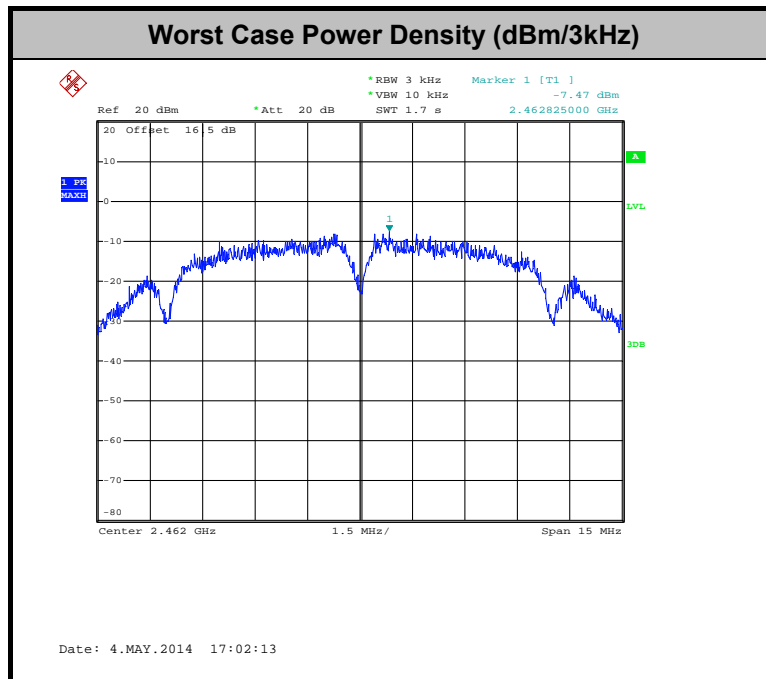

3.4 Conducted Band Edges and Spurious Emission Measurement

3.4.1 Limit of Conducted Band Edges and Spurious Emission Measurement

In any 100 kHz bandwidth outside of the authorized frequency band, the emissions which fall in the non-restricted bands shall be attenuated at least 20 dB / 30dB relative to the maximum PSD level in 100 kHz by RF conducted measurement and radiated emissions which fall in the restricted bands, as defined in Section 15.205(a), must also comply with the radiated emission limits specified in Section 15.209(a).

3.4.2 Measuring Instruments

The measuring equipment is listed in the section 4 of this test report.

3.4.3 Test Procedures

1. The testing follows FCC KDB Publication No. 558074 D01 DTS Meas. Guidance v03r01.
2. The RF output of EUT was connected to the spectrum analyzer by RF cable and attenuator. The path loss was compensated to the results for each measurement.
3. Set to the maximum power setting and enable the EUT transmit continuously.
4. Set RBW = 100 kHz, VBW=300 kHz, Peak Detector. Unwanted Emissions measured in any 100 kHz bandwidth outside of the authorized frequency band shall be attenuated by at least 20 dB relative to the maximum in-band peak PSD level in 100 kHz when maximum peak conducted output power procedure is used. If the transmitter complies with the conducted power limits based on the use of RMS averaging over a time interval, the attenuation required under this paragraph shall be 30 dB instead of 20 dB per 15.247(d).
5. Measure and record the results in the test report.
6. The RF fundamental frequency should be excluded against the limit line in the operating frequency band.

3.4.4 Test Setup

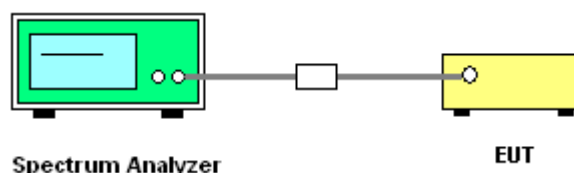



3.4.5 Test Result of Conducted Band Edges and Spurious Emission

Test Mode :	802.11b	Temperature :	23~24°C
Test Band :	2.4GHz Low	Relative Humidity :	47~48%
Test Channel :	01	Test Engineer :	Adonis Li

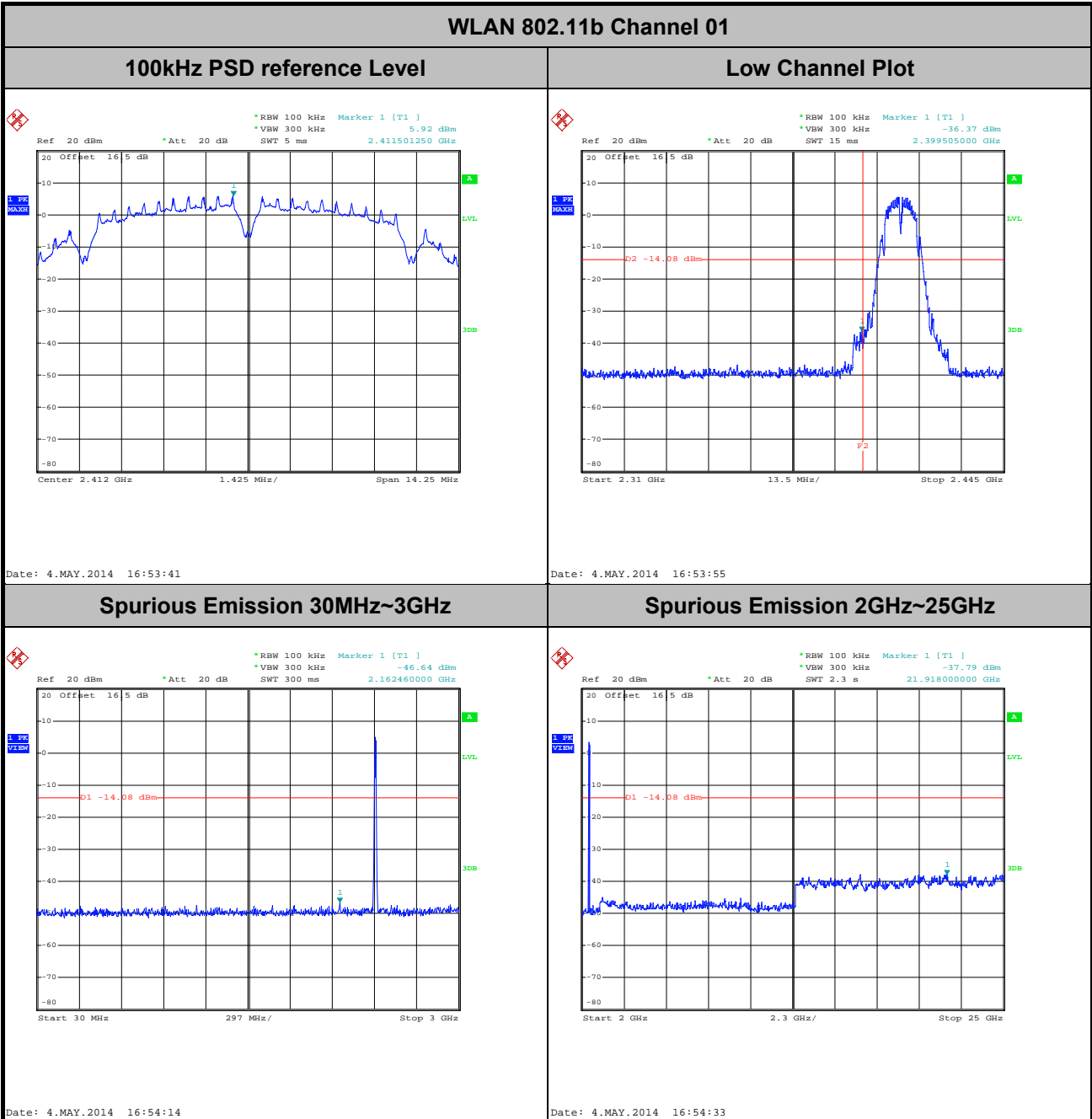



Test Mode :	802.11b	Temperature :	23~24°C
Test Band :	2.4GHz Mid	Relative Humidity :	47~48%
Test Channel :	06	Test Engineer :	Adonis Li

WLAN 802.11b Channel 06

100kHz PSD reference Level

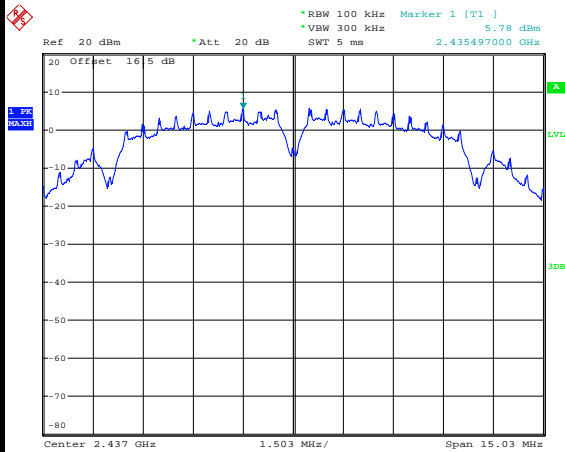

Date: 4.MAY.2014 16:58:17

Spurious Emission 30MHz~3GHz

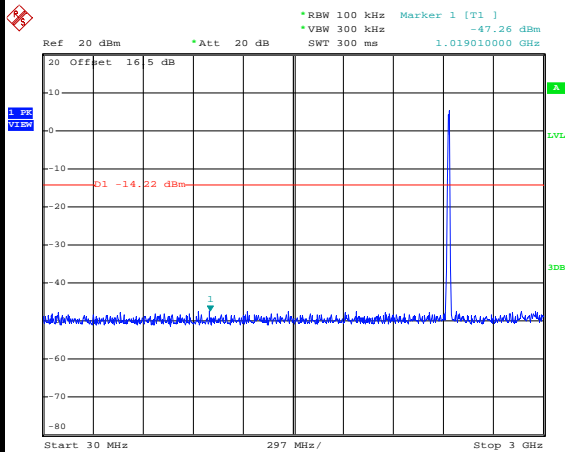

Date: 4.MAY.2014 16:58:37

Spurious Emission 2GHz~25GHz

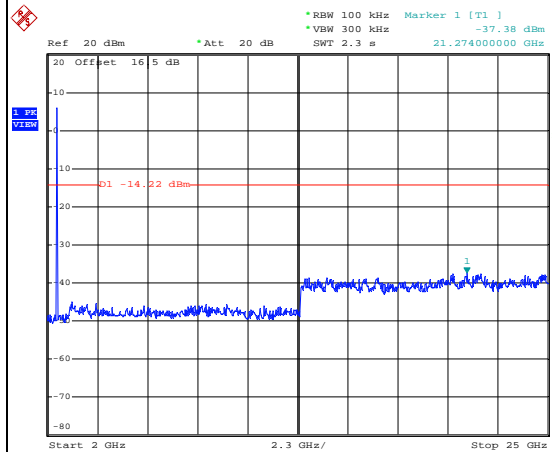

Date: 4.MAY.2014 16:58:56



Test Mode :	802.11b	Temperature :	23~24°C
Test Band :	2.4GHz High	Relative Humidity :	47~48%
Test Channel :	11	Test Engineer :	Adonis Li

WLAN 802.11b Channel 11

100kHz PSD reference Level

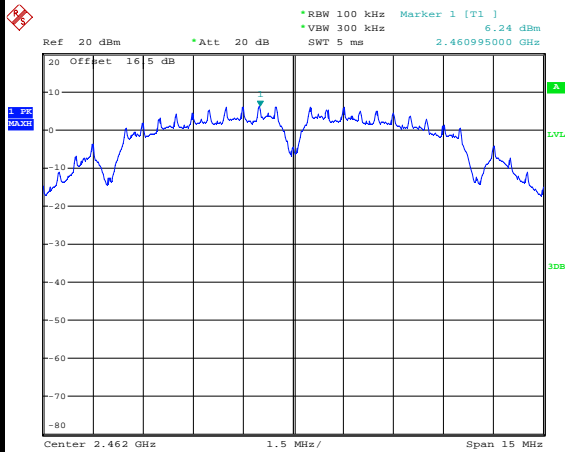

Date: 4.MAY.2014 17:02:21

High Channel Plot

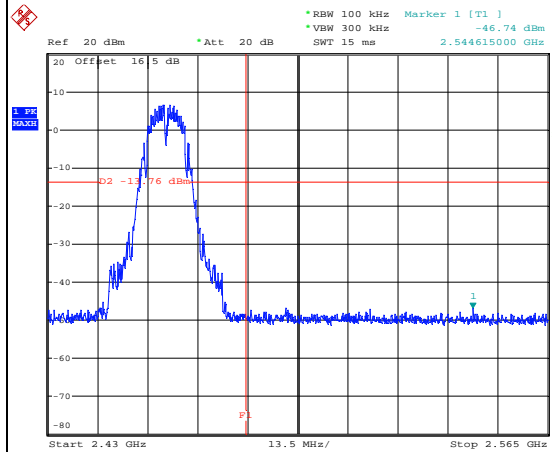

Date: 4.MAY.2014 17:02:35

Spurious Emission 30MHz~3GHz

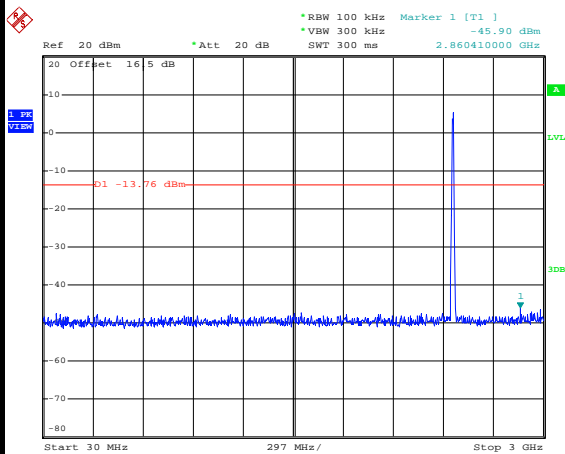

Date: 4.MAY.2014 17:02:54

Spurious Emission 2GHz~25GHz

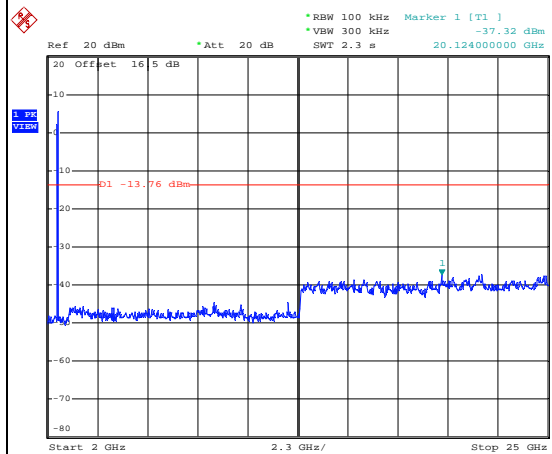

Date: 4.MAY.2014 17:03:13



Test Mode :	802.11g	Temperature :	23~24°C
Test Band :	2.4GHz Low	Relative Humidity :	47~48%
Test Channel :	01	Test Engineer :	Adonis Li

WLAN 802.11g Channel 01

100kHz PSD reference Level

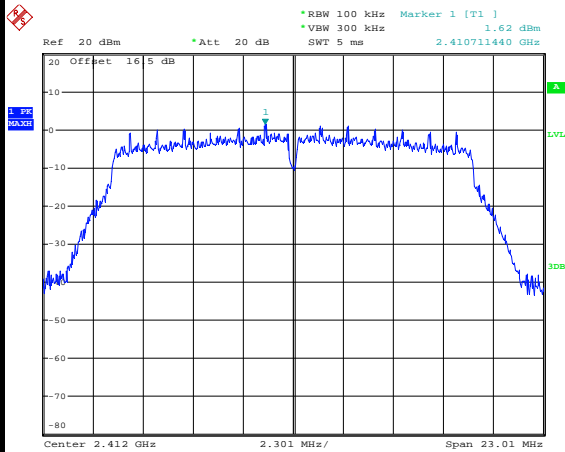

Date: 14.MAY.2014 11:19:23

Low Channel Plot

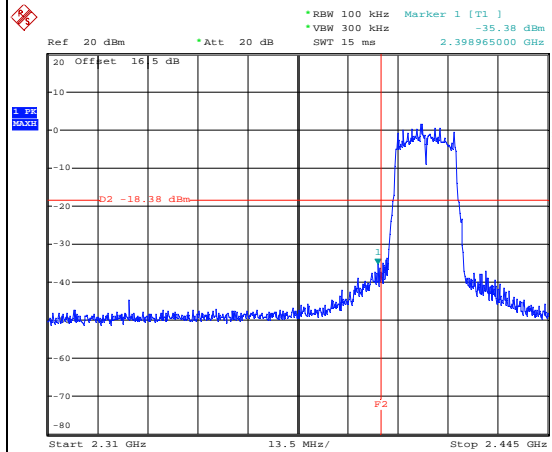

Date: 14.MAY.2014 11:19:37

Spurious Emission 30MHz~3GHz

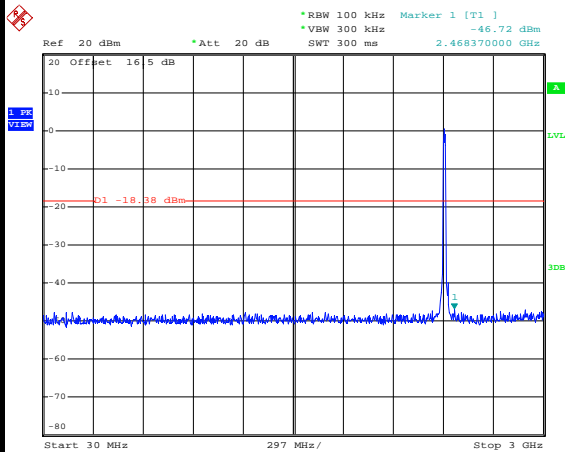

Date: 14.MAY.2014 11:19:56

Spurious Emission 2GHz~25GHz

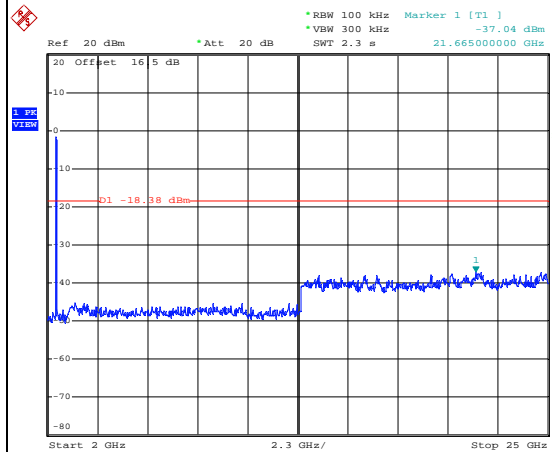

Date: 14.MAY.2014 11:20:15



Test Mode :	802.11g	Temperature :	23~24°C
Test Band :	2.4GHz Mid	Relative Humidity :	47~48%
Test Channel :	06	Test Engineer :	Adonis Li

WLAN 802.11g Channel 06

100kHz PSD reference Level

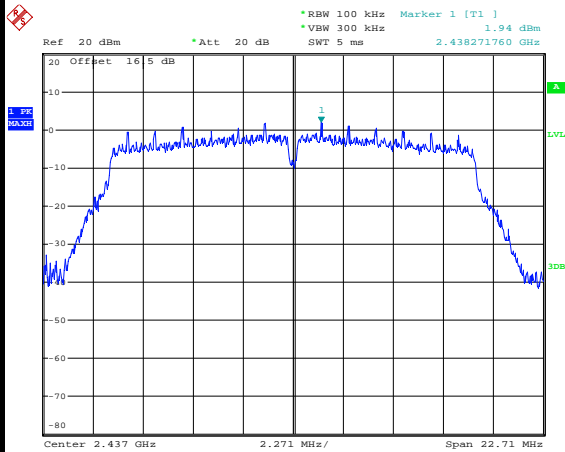

Date: 14.MAY.2014 11:39:06

Spurious Emission 30MHz~3GHz

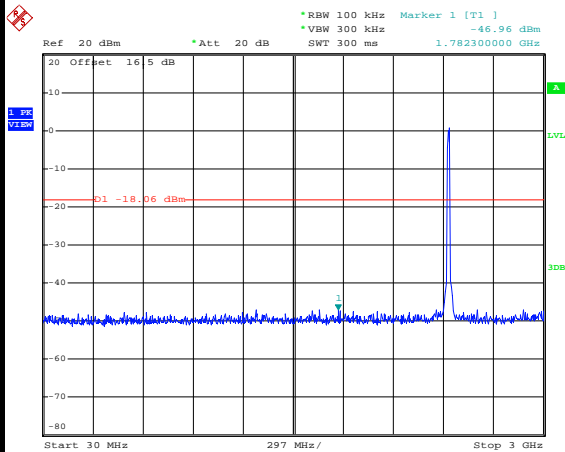

Date: 14.MAY.2014 11:39:26

Spurious Emission 2GHz~25GHz

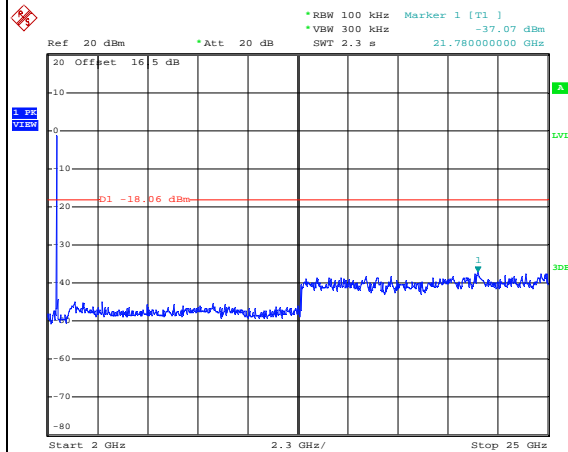

Date: 14.MAY.2014 11:39:44



Test Mode :	802.11g	Temperature :	23~24°C
Test Band :	2.4GHz High	Relative Humidity :	47~48%
Test Channel :	11	Test Engineer :	Adonis Li

WLAN 802.11g Channel 11

100kHz PSD reference Level

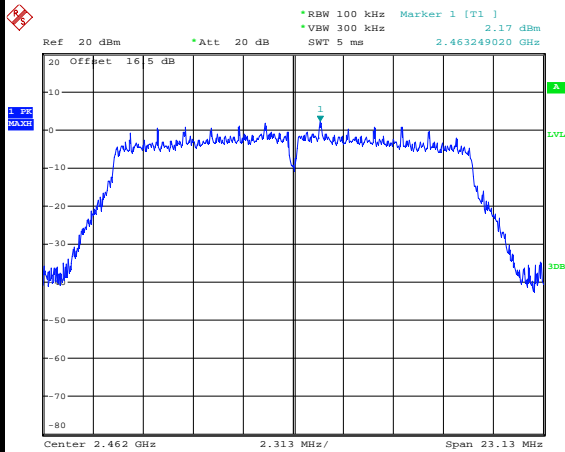

Date: 14.MAY.2014 11:47:14

High Channel Plot

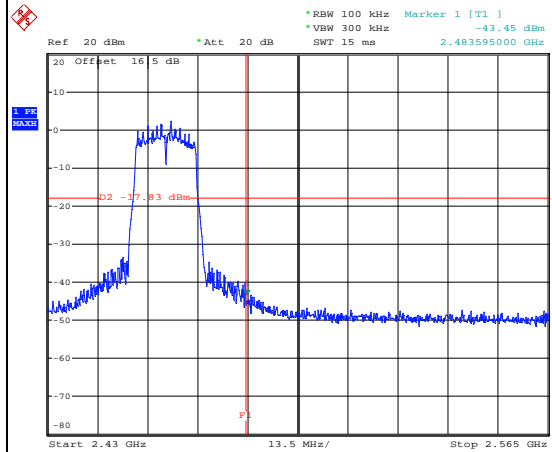

Date: 14.MAY.2014 11:47:28

Spurious Emission 30MHz~3GHz

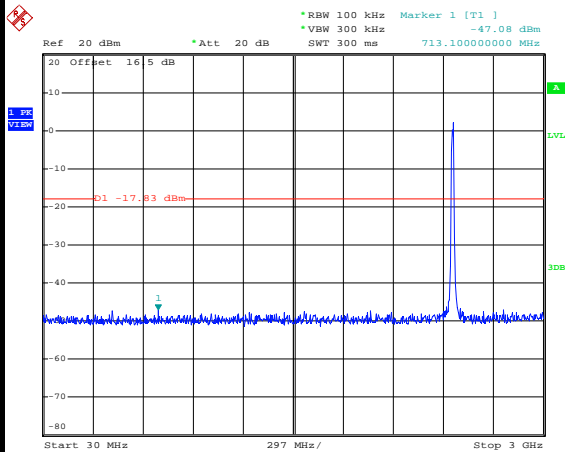

Date: 14.MAY.2014 11:47:47

Spurious Emission 2GHz~25GHz

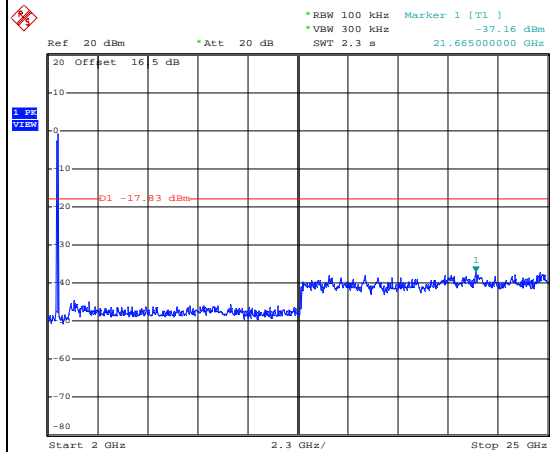

Date: 14.MAY.2014 11:48:06



Test Mode :	802.11n HT20	Temperature :	23~24°C
Test Band :	2.4GHz Low	Relative Humidity :	47~48%
Test Channel :	01	Test Engineer :	Adonis Li

WLAN 802.11n HT20 Channel 01

100kHz PSD reference Level

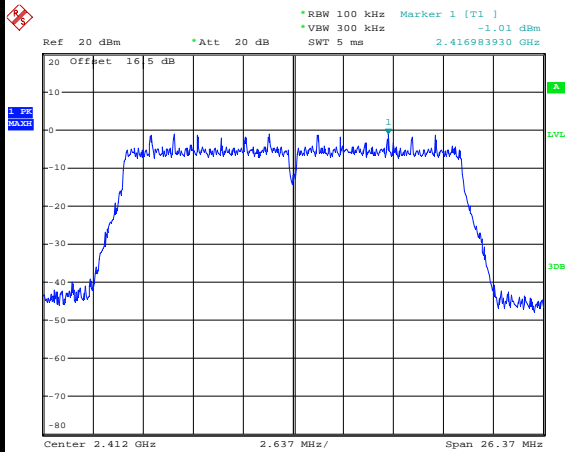

Date: 14.MAY.2014 11:51:42

Low Channel Plot

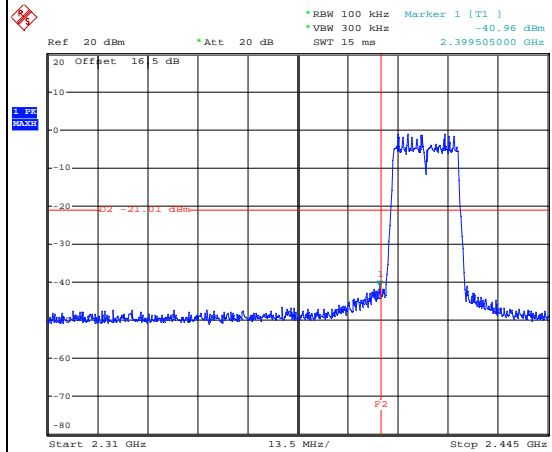

Date: 14.MAY.2014 11:51:56

Spurious Emission 30MHz~3GHz

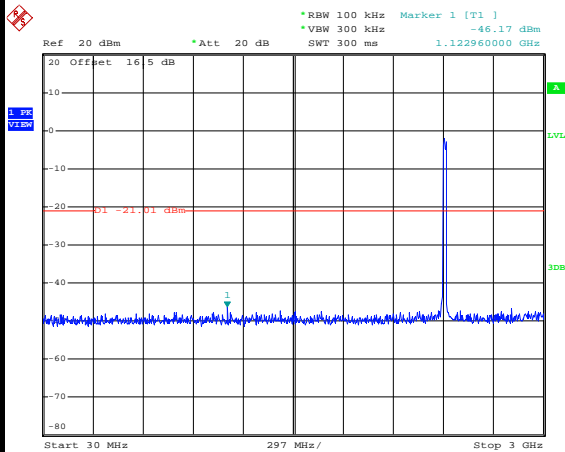

Date: 14.MAY.2014 11:52:15

Spurious Emission 2GHz~25GHz

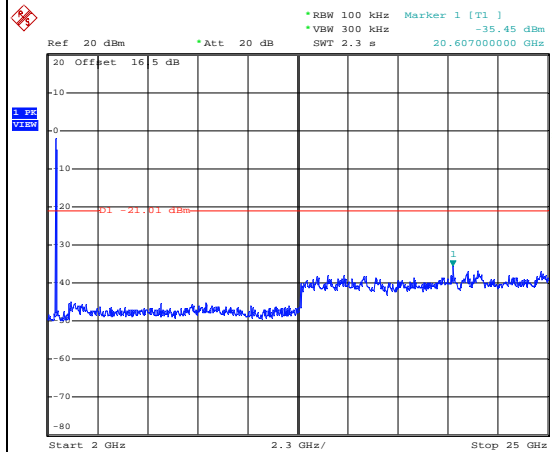

Date: 14.MAY.2014 11:52:34



Test Mode :	802.11n HT20	Temperature :	23~24°C
Test Band :	2.4GHz Mid	Relative Humidity :	47~48%
Test Channel :	06	Test Engineer :	Adonis Li

WLAN 802.11n HT20 Channel 06

100kHz PSD reference Level

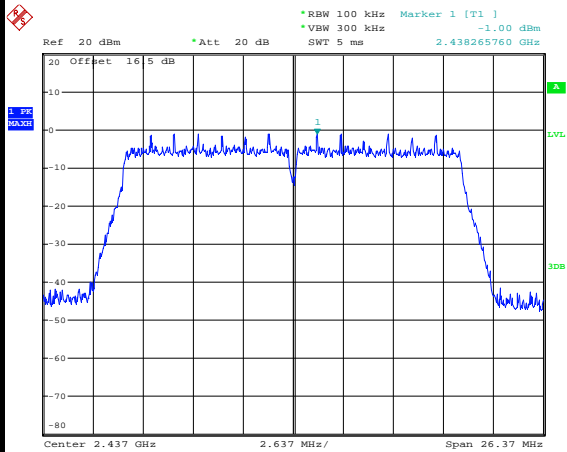

Date: 14.MAY.2014 11:56:23

Spurious Emission 30MHz~3GHz

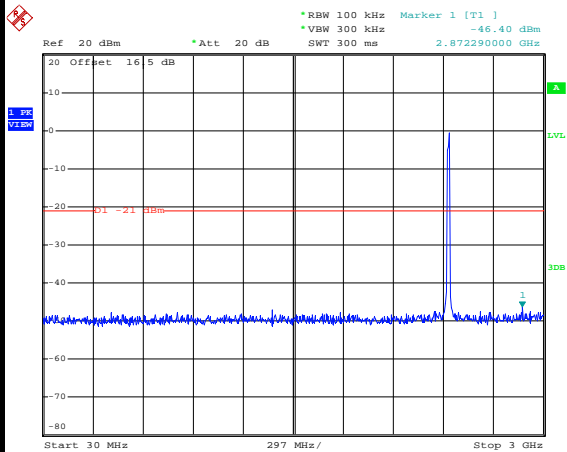

Date: 14.MAY.2014 11:57:40

Spurious Emission 2GHz~25GHz

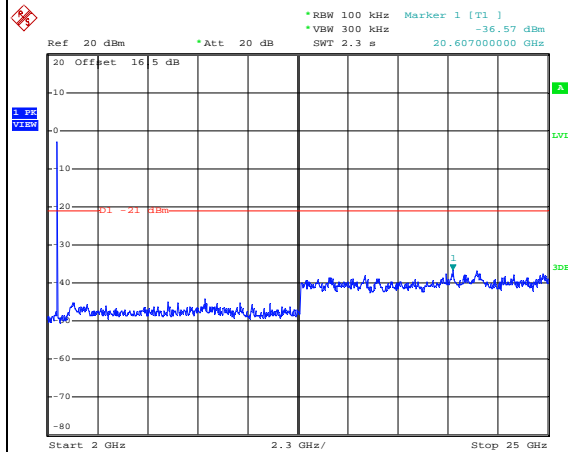

Date: 14.MAY.2014 11:57:59



Test Mode :	802.11n HT20	Temperature :	23~24°C
Test Band :	2.4GHz High	Relative Humidity :	47~48%
Test Channel :	11	Test Engineer :	Adonis Li

WLAN 802.11n HT20 Channel 11

100kHz PSD reference Level

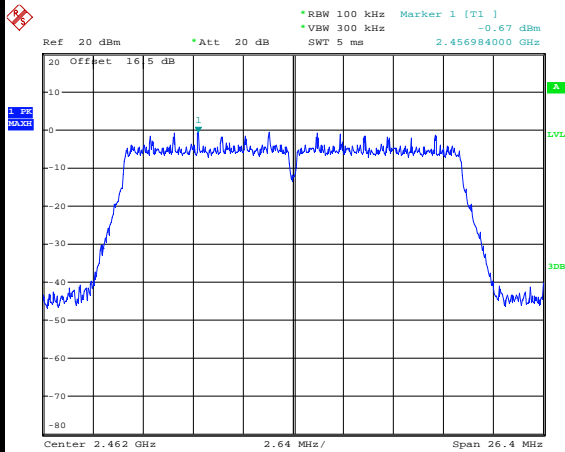

Date: 14.MAY.2014 12:01:23

High Channel Plot

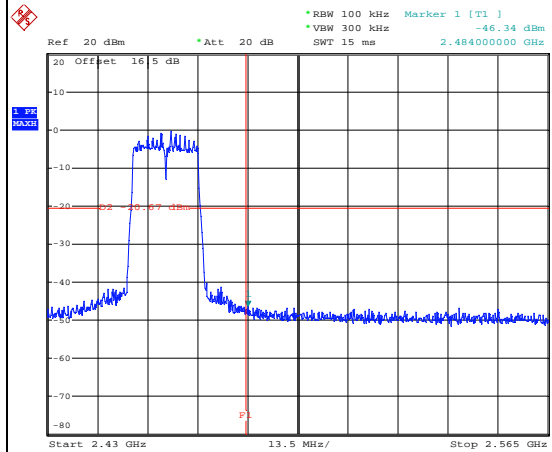

Date: 14.MAY.2014 12:01:37

Spurious Emission 30MHz~3GHz

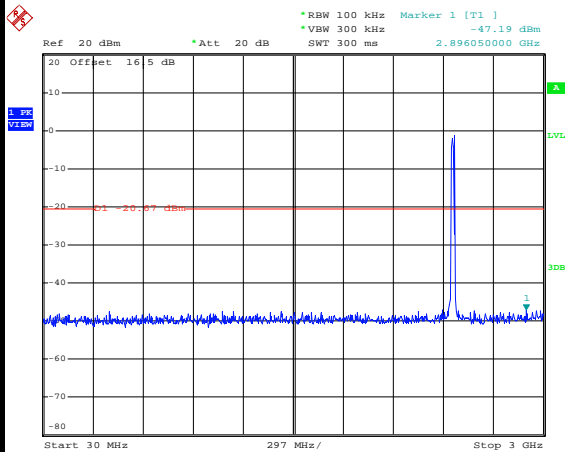

Date: 14.MAY.2014 12:01:56

Spurious Emission 2GHz~25GHz

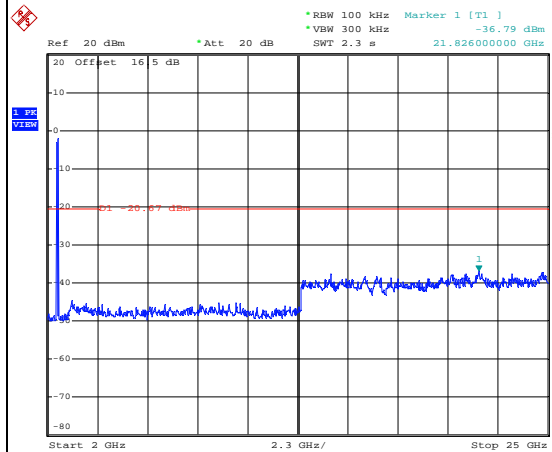

Date: 14.MAY.2014 12:02:14



Test Mode :	802.11n HT40	Temperature :	23~24°C
Test Band :	2.4GHz Low	Relative Humidity :	47~48%
Test Channel :	03	Test Engineer :	Adonis Li

WLAN 802.11n HT40 Channel 03

100kHz PSD reference Level

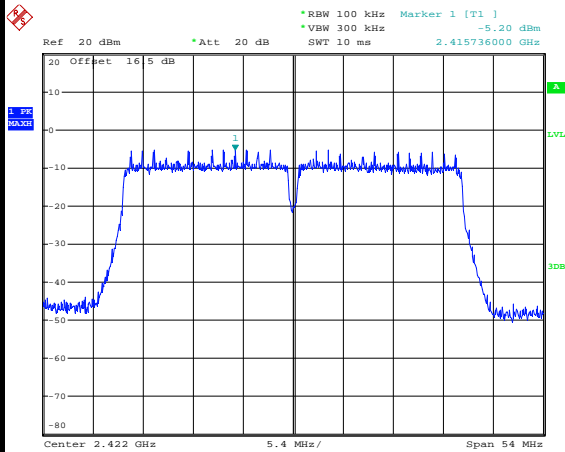

Date: 14.MAY.2014 12:12:50

Low Channel Plot

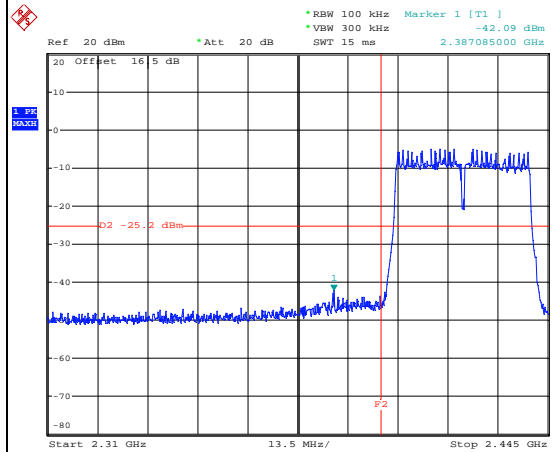

Date: 14.MAY.2014 12:13:04

Spurious Emission 30MHz~3GHz

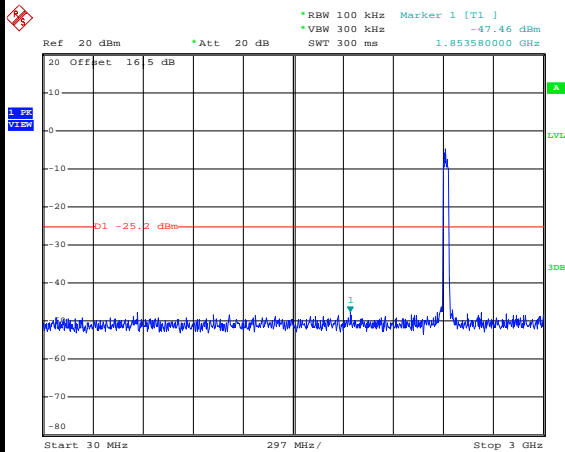

Date: 14.MAY.2014 12:59:14

Spurious Emission 2GHz~25GHz

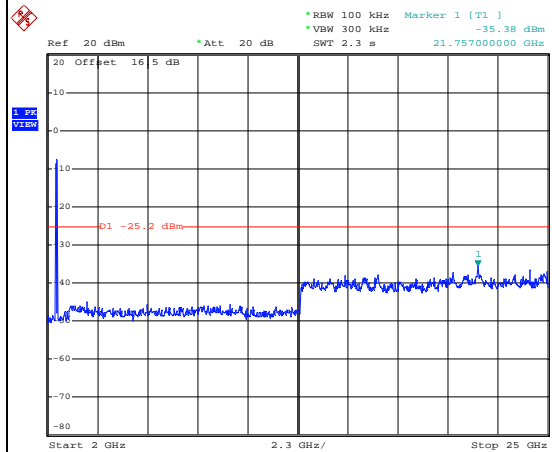

Date: 14.MAY.2014 12:14:52



Test Mode :	802.11n HT40	Temperature :	23~24°C
Test Band :	2.4GHz Mid	Relative Humidity :	47~48%
Test Channel :	06	Test Engineer :	Adonis Li

WLAN 802.11n HT40 Channel 06

100kHz PSD reference Level

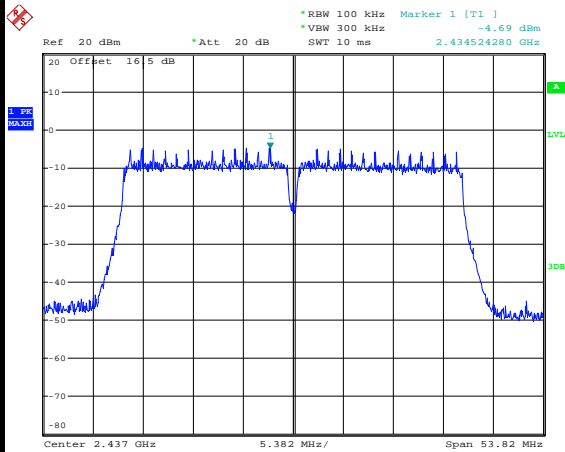

Date: 14.MAY.2014 12:18:45

Spurious Emission 30MHz~3GHz

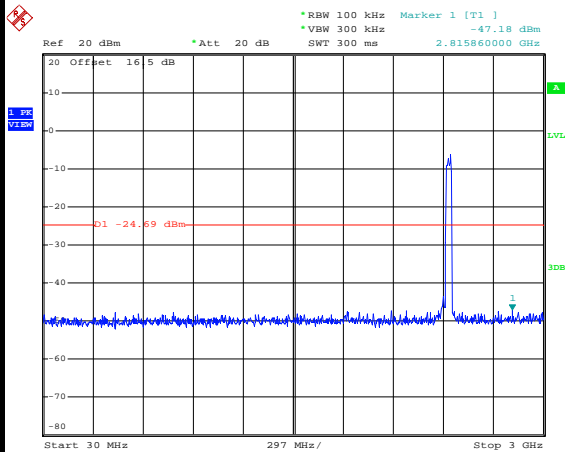

Date: 14.MAY.2014 14:52:32

Spurious Emission 2GHz~25GHz

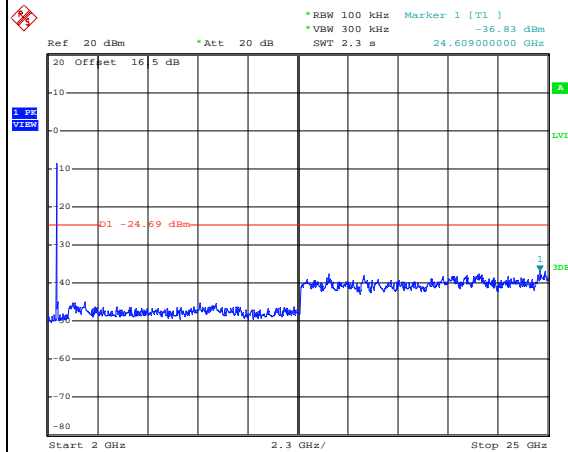

Date: 14.MAY.2014 14:52:51



Test Mode :	802.11n HT40	Temperature :	23~24°C
Test Band :	2.4GHz High	Relative Humidity :	47~48%
Test Channel :	09	Test Engineer :	Adonis Li

WLAN 802.11n HT40 Channel 09

100kHz PSD reference Level

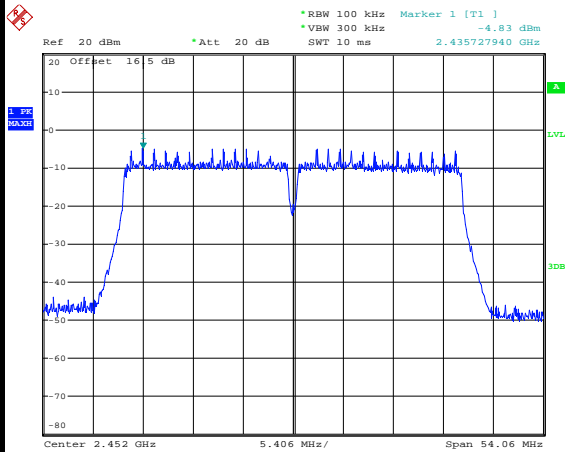

Date: 14.MAY.2014 12:23:29

High Channel Plot

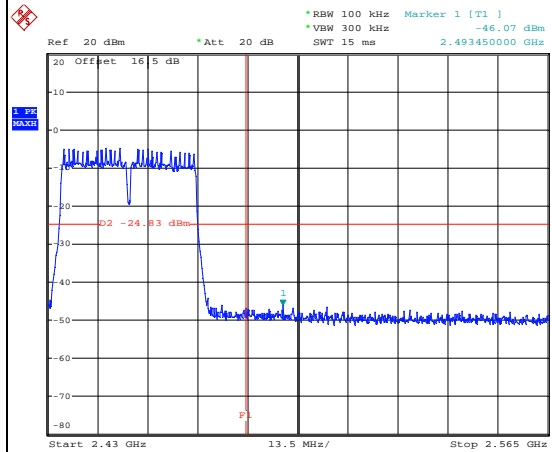

Date: 14.MAY.2014 12:23:43

Spurious Emission 30MHz~3GHz

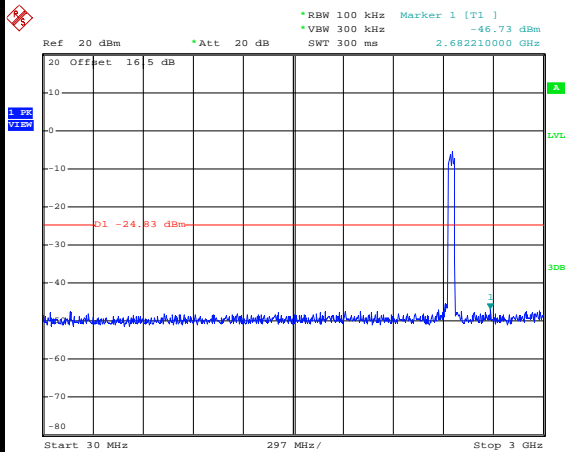

Date: 14.MAY.2014 12:24:02

Spurious Emission 2GHz~25GHz

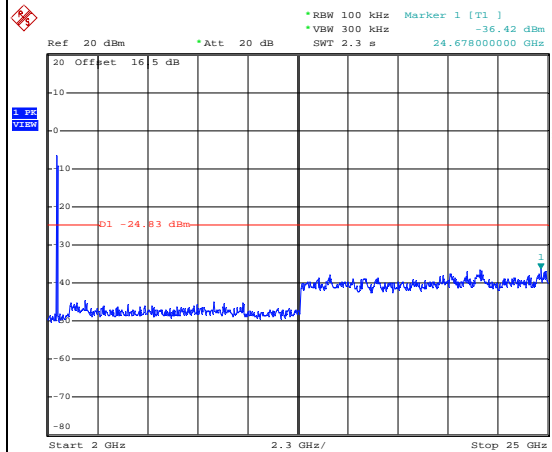

Date: 14.MAY.2014 12:24:21



3.5 Radiated Band Edges and Spurious Emission Measurement

3.5.1 Limit of Radiated band edge and Spurious Emission Measurement

In any 100 kHz bandwidth outside the intentional radiator frequency band, all harmonics/spurious must be at least 20 dB below the highest emission level within the authorized band. If the output power of this device was measured by spectrum analyzer, the attenuation under this paragraph shall be 30 dB instead of 20 dB. In addition, radiated emissions which fall in the restricted bands must also comply with the FCC section 15.209 limits as below.

Frequency (MHz)	Field Strength (microvolts/meter)	Measurement Distance (meters)
0.009 – 0.490	2400/F(kHz)	300
0.490 – 1.705	24000/F(kHz)	30
1.705 – 30.0	30	30
30 – 88	100	3
88 – 216	150	3
216 - 960	200	3
Above 960	500	3

3.5.2 Measuring Instruments

The measuring equipment is listed in the section 4 of this test report.



3.5.3 Test Procedures

1. The testing follows FCC KDB Publication No. 558074 D01 DTS Meas. Guidance v03r01.
2. The EUT was arranged to its worst case and then tune the antenna tower (from 1 m to 4 m) and turntable (from 0 degree to 360 degrees) to find the maximum reading. A pre-amp and a high pass filter are used for the test in order to get better signal level.
3. The EUT was placed on a turntable with 0.8 meter above ground.
4. The EUT was set 3 meters from the interference receiving antenna, which was mounted on the top of a variable height antenna tower.
5. Corrected Reading: Antenna Factor + Cable Loss + Read Level - Preamp Factor = Level
6. For measurement below 1GHz, If the emission level of the EUT measured by the peak detector is 3 dB lower than the applicable limit, the peak emission level will be reported. Otherwise, the emission measurement will be repeated using the quasi-peak detector and reported.
7. Use the following spectrum analyzer settings:
 - (1) Span shall wide enough to fully capture the emission being measured;
 - (2) Set RBW=100 kHz for f < 1 GHz; VBW ≥ RBW; Sweep = auto; Detector function = peak; Trace = max hold;
 - (3) Set RBW = 1 MHz, VBW= 3MHz for f ≥ 1 GHz for peak measurement.
 For average measurement:
 - VBW = 10 Hz, when duty cycle is no less than 98 percent.
 - VBW ≥ 1/T, when duty cycle is less than 98 percent where T is the minimum transmission duration over which the transmitter is on and is transmitting at its maximum power control level for the tested mode of operation.

Band	Duty Cycle (%)	T(ms)	1/T(kHz)	VBW Setting
802.11b	98.13	-	-	10Hz
802.11g	88.54	1.390	0.719	1kHz
2.4GHz 802.11n HT20	88.96	1.306	0.766	1kHz
2.4GHz 802.11n HT40	79.32	0.652	1.534	3kHz

3.5.4 Test Setup

For radiated emissions below 30MHz

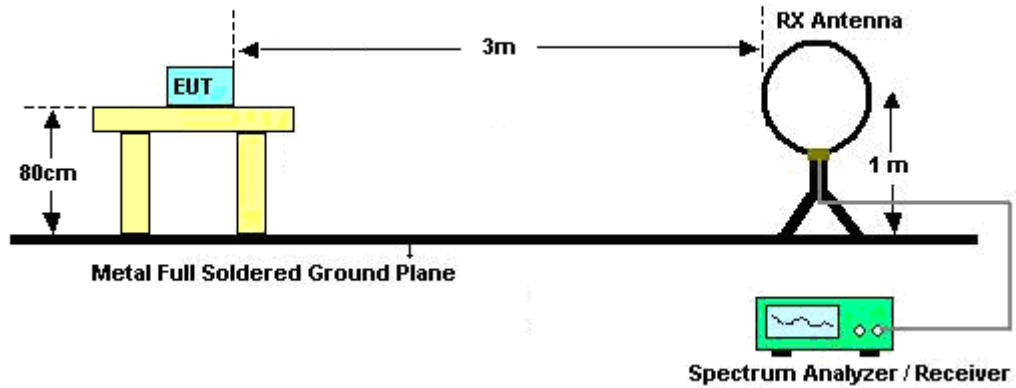

For radiated emissions from 30MHz to 1GHz

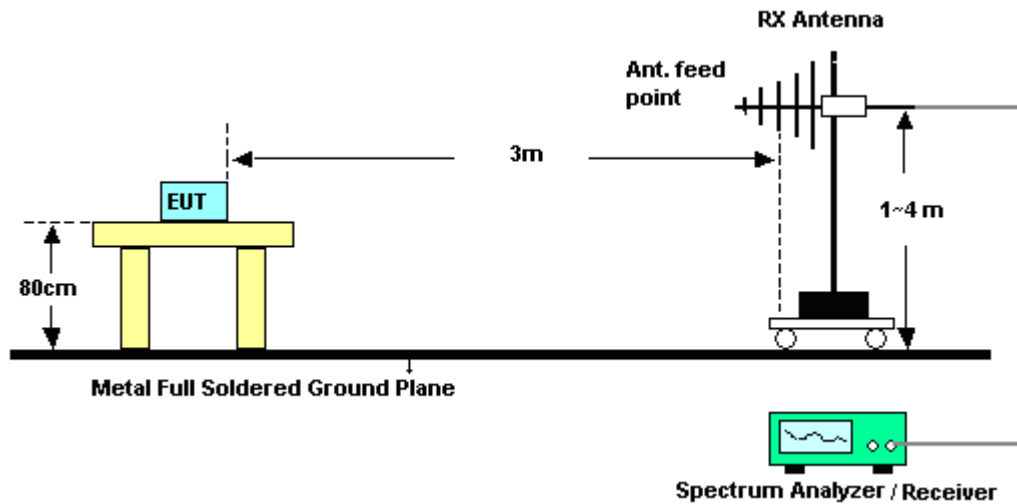

For radiated emissions above 1GHz

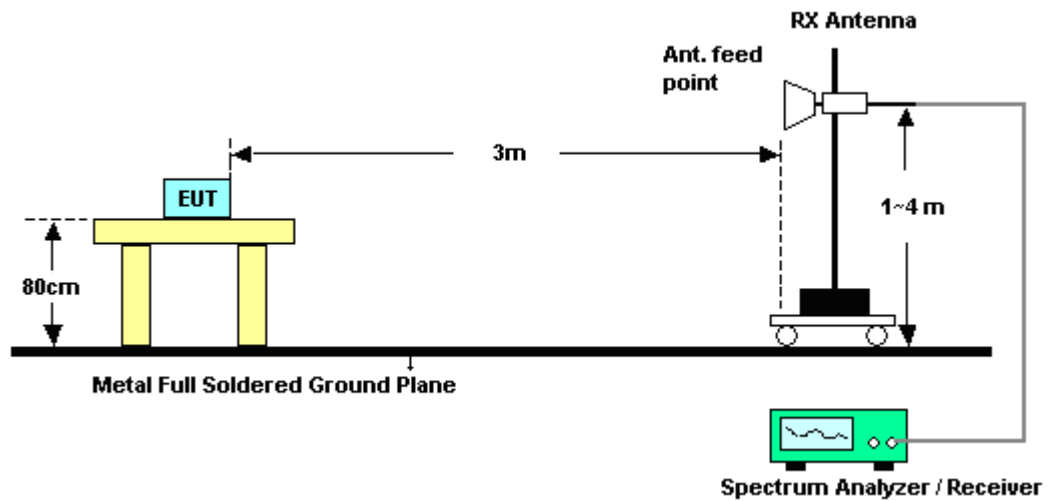

3.5.5 Test Results of Radiated Spurious Emissions (9kHz ~ 30MHz)

The low frequency, which started from 9 kHz to 30MHz, was pre-scanned and the result which was 20dB lower than the limit line per 15.31(o) was not reported.



3.5.6 Test Result of Radiated Spurious at Band Edges

Test Mode :	802.11b	Temperature :	23~24°C
Test Band :	Low	Relative Humidity :	43~44%
Test Channel :	01	Test Engineer :	Stone Gu

ANTENNA POLARITY : HORIZONTAL										
Frequency (MHz)	Level (dBμV/m)	Over Limit (dB)	Limit Line (dBμV/m)	Read Level (dBμV)	Antenna Factor (dB)	Cable Loss (dB)	Preamp Factor (dB)	Ant Pos (cm)	Table Pos (deg)	Remark
2369.13	56.39	-17.61	74	53.24	32.83	3.58	33.26	100	229	Peak
2389.83	42.03	-11.97	54	38.84	32.86	3.59	33.26	100	229	Average

ANTENNA POLARITY : VERTICAL										
Frequency (MHz)	Level (dBμV/m)	Over Limit (dB)	Limit Line (dBμV/m)	Read Level (dBμV)	Antenna Factor (dB)	Cable Loss (dB)	Preamp Factor (dB)	Ant Pos (cm)	Table Pos (deg)	Remark
2376.87	54.9	-19.1	74	51.75	32.83	3.58	33.26	100	116	Peak
2377.05	38.94	-15.06	54	35.79	32.83	3.58	33.26	100	116	Average

Test Mode :	802.11b	Temperature :	23~24°C
Test Band :	High	Relative Humidity :	43~44%
Test Channel :	11	Test Engineer :	Stone Gu

ANTENNA POLARITY : HORIZONTAL										
Frequency (MHz)	Level (dBμV/m)	Over Limit (dB)	Limit Line (dBμV/m)	Read Level (dBμV)	Antenna Factor (dB)	Cable Loss (dB)	Preamp Factor (dB)	Ant Pos (cm)	Table Pos (deg)	Remark
2484.46	52.23	-21.77	74	48.86	33.01	3.65	33.29	100	228	Peak
2485.51	41.39	-12.61	54	38.02	33.01	3.65	33.29	100	221	Average

ANTENNA POLARITY : VERTICAL										
Frequency (MHz)	Level (dBμV/m)	Over Limit (dB)	Limit Line (dBμV/m)	Read Level (dBμV)	Antenna Factor (dB)	Cable Loss (dB)	Preamp Factor (dB)	Ant Pos (cm)	Table Pos (deg)	Remark
2485	49.06	-24.94	74	45.69	33.01	3.65	33.29	100	189	Peak
2485.51	36.99	-17.01	54	33.62	33.01	3.65	33.29	100	189	Average



Test Mode :	802.11g	Temperature :	23~24°C
Test Band :	Low	Relative Humidity :	43~44%
Test Channel :	01	Test Engineer :	Stone Gu

ANTENNA POLARITY : HORIZONTAL										
Frequency (MHz)	Level (dBμV/m)	Over Limit (dB)	Limit Line (dBμV/m)	Read Level (dBμV)	Antenna Factor (dB)	Cable Loss (dB)	Preamp Factor (dB)	Ant Pos (cm)	Table Pos (deg)	Remark
2389.2	69.46	-4.54	74	66.27	32.86	3.59	33.26	187	169	Peak
2389.74	48.04	-5.96	54	44.85	32.86	3.59	33.26	187	169	Average

ANTENNA POLARITY : VERTICAL										
Frequency (MHz)	Level (dBμV/m)	Over Limit (dB)	Limit Line (dBμV/m)	Read Level (dBμV)	Antenna Factor (dB)	Cable Loss (dB)	Preamp Factor (dB)	Ant Pos (cm)	Table Pos (deg)	Remark
2388.93	65.63	-8.37	74	62.44	32.86	3.59	33.26	100	335	Peak
2389.83	44.55	-9.45	54	41.36	32.86	3.59	33.26	100	335	Average

Test Mode :	802.11g	Temperature :	23~24°C
Test Band :	High	Relative Humidity :	43~44%
Test Channel :	11	Test Engineer :	Stone Gu

ANTENNA POLARITY : HORIZONTAL										
Frequency (MHz)	Level (dBμV/m)	Over Limit (dB)	Limit Line (dBμV/m)	Read Level (dBμV)	Antenna Factor (dB)	Cable Loss (dB)	Preamp Factor (dB)	Ant Pos (cm)	Table Pos (deg)	Remark
2483.77	69.94	-4.06	74	66.57	33.01	3.65	33.29	100	227	Peak
2483.56	46.07	-7.93	54	42.7	33.01	3.65	33.29	100	227	Average

ANTENNA POLARITY : VERTICAL										
Frequency (MHz)	Level (dBμV/m)	Over Limit (dB)	Limit Line (dBμV/m)	Read Level (dBμV)	Antenna Factor (dB)	Cable Loss (dB)	Preamp Factor (dB)	Ant Pos (cm)	Table Pos (deg)	Remark
2483.74	64.26	-9.74	74	60.89	33.01	3.65	33.29	176	189	Peak
2483.65	42.72	-11.28	54	39.35	33.01	3.65	33.29	176	189	Average



Test Mode :	802.11n HT20	Temperature :	23~24°C
Test Band :	Low	Relative Humidity :	43~44%
Test Channel :	01	Test Engineer :	Stone Gu

ANTENNA POLARITY : HORIZONTAL										
Frequency (MHz)	Level (dBμV/m)	Over Limit (dB)	Limit Line (dBμV/m)	Read Level (dBμV)	Antenna Factor (dB)	Cable Loss (dB)	Preamp Factor (dB)	Ant Pos (cm)	Table Pos (deg)	Remark
2389.65	64.87	-9.13	74	61.68	32.86	3.59	33.26	100	330	Peak
2389.74	44.15	-9.85	54	40.96	32.86	3.59	33.26	100	330	Average

ANTENNA POLARITY : VERTICAL										
Frequency (MHz)	Level (dBμV/m)	Over Limit (dB)	Limit Line (dBμV/m)	Read Level (dBμV)	Antenna Factor (dB)	Cable Loss (dB)	Preamp Factor (dB)	Ant Pos (cm)	Table Pos (deg)	Remark
2389.92	63.72	-10.28	74	60.53	32.86	3.59	33.26	100	347	Peak
2389.92	43.39	-10.61	54	40.2	32.86	3.59	33.26	100	347	Average

Test Mode :	802.11n HT20	Temperature :	23~24°C
Test Band :	High	Relative Humidity :	43~44%
Test Channel :	11	Test Engineer :	Stone Gu

ANTENNA POLARITY : HORIZONTAL										
Frequency (MHz)	Level (dBμV/m)	Over Limit (dB)	Limit Line (dBμV/m)	Read Level (dBμV)	Antenna Factor (dB)	Cable Loss (dB)	Preamp Factor (dB)	Ant Pos (cm)	Table Pos (deg)	Remark
2484.79	69.91	-4.09	74	66.54	33.01	3.65	33.29	100	226	Peak
2483.56	42.03	-11.97	54	38.66	33.01	3.65	33.29	100	225	Average

ANTENNA POLARITY : VERTICAL										
Frequency (MHz)	Level (dBμV/m)	Over Limit (dB)	Limit Line (dBμV/m)	Read Level (dBμV)	Antenna Factor (dB)	Cable Loss (dB)	Preamp Factor (dB)	Ant Pos (cm)	Table Pos (deg)	Remark
2483.5	65.08	-8.92	74	61.71	33.01	3.65	33.29	198	117	Peak
2483.59	40.49	-13.51	54	37.12	33.01	3.65	33.29	198	117	Average



Test Mode :	802.11n HT40	Temperature :	23~24°C
Test Band :	Low	Relative Humidity :	43~44%
Test Channel :	03	Test Engineer :	Stone Gu

ANTENNA POLARITY : HORIZONTAL										
Frequency (MHz)	Level (dBμV/m)	Over Limit (dB)	Limit Line (dBμV/m)	Read Level (dBμV)	Antenna Factor (dB)	Cable Loss (dB)	Preamp Factor (dB)	Ant Pos (cm)	Table Pos (deg)	Remark
2388.48	68.21	-5.79	74	65.02	32.86	3.59	33.26	100	232	Peak
2389.74	49.68	-4.32	54	46.49	32.86	3.59	33.26	100	232	Average
2483.98	51.31	-22.69	74	47.94	33.01	3.65	33.29	145	338	Peak
2483.56	36.26	-17.74	54	32.89	33.01	3.65	33.29	145	338	Average

ANTENNA POLARITY : VERTICAL										
Frequency (MHz)	Level (dBμV/m)	Over Limit (dB)	Limit Line (dBμV/m)	Read Level (dBμV)	Antenna Factor (dB)	Cable Loss (dB)	Preamp Factor (dB)	Ant Pos (cm)	Table Pos (deg)	Remark
2388.21	64.38	-9.62	74	61.19	32.86	3.59	33.26	125	216	Peak
2389.74	46.49	-7.51	54	43.3	32.86	3.59	33.26	125	216	Average
2484.19	47.96	-26.04	74	44.59	33.01	3.65	33.29	157	333	Peak
2492.86	34.3	-19.7	54	30.89	33.05	3.66	33.3	157	333	Average



Test Mode :	802.11n HT40	Temperature :	23~24°C
Test Band :	High	Relative Humidity :	43~44%
Test Channel :	09	Test Engineer :	Stone Gu

ANTENNA POLARITY : HORIZONTAL										
Frequency (MHz)	Level (dBμV/m)	Over Limit (dB)	Limit Line (dBμV/m)	Read Level (dBμV)	Antenna Factor (dB)	Cable Loss (dB)	Preamp Factor (dB)	Ant Pos (cm)	Table Pos (deg)	Remark
2383.62	62.28	-11.72	74	59.13	32.83	3.58	33.26	152	336	Peak
2389.92	43.04	-10.96	54	39.85	32.86	3.59	33.26	124	335	Average
2483.59	68.54	-5.46	74	65.17	33.01	3.65	33.29	100	231	Peak
2483.74	41.46	-12.54	54	38.09	33.01	3.65	33.29	100	231	Average

ANTENNA POLARITY : VERTICAL										
Frequency (MHz)	Level (dBμV/m)	Over Limit (dB)	Limit Line (dBμV/m)	Read Level (dBμV)	Antenna Factor (dB)	Cable Loss (dB)	Preamp Factor (dB)	Ant Pos (cm)	Table Pos (deg)	Remark
2389.92	58.32	-15.68	74	55.13	32.86	3.59	33.26	100	338	Peak
2389.38	39.8	-14.2	54	36.61	32.86	3.59	33.26	100	260	Average
2484.4	65.12	-8.88	74	61.75	33.01	3.65	33.29	145	191	Peak
2483.59	40.19	-13.81	54	36.82	33.01	3.65	33.29	145	191	Average

3.5.7 Test Result of Radiated Spurious Emission (30MHz ~ 10th Harmonic)

Note: Pre-scanned all test modes and only choose the worst case mode recorded in the test report for radiated spurious emission below 1GHz.

Test Mode :	802.11b	Temperature :	23~24°C
Test Channel :	01	Relative Humidity :	43~44%
Test Engineer :	Stone Gu	Polarization :	Horizontal
Remark :	1. 2412 MHz is fundamental signal which can be ignored. 2. Average measurement was not performed if peak level went lower than the average limit.		

Frequency (MHz)	Level (dB μ V/m)	Over Limit (dB)	Limit Line (dB μ V/m)	Read Level (dB μ V)	Antenna Factor (dB)	Cable Loss (dB)	Preamp Factor (dB)	Ant Pos (cm)	Table Pos (deg)	Remark
2412	106.05	-	-	102.75	32.95	3.63	33.28	127	326	Peak
2412	100.17	-	-	96.87	32.95	3.63	33.28	127	326	Average
4824	47.96	-26.04	74	41.34	35.17	5.25	33.8	100	0	Peak

Test Mode :	802.11b	Temperature :	23~24°C
Test Channel :	01	Relative Humidity :	43~44%
Test Engineer :	Stone Gu	Polarization :	Vertical
Remark :	1. 2412 MHz is fundamental signal which can be ignored. 2. Average measurement was not performed if peak level went lower than the average limit.		

Frequency (MHz)	Level (dB μ V/m)	Over Limit (dB)	Limit Line (dB μ V/m)	Read Level (dB μ V)	Antenna Factor (dB)	Cable Loss (dB)	Preamp Factor (dB)	Ant Pos (cm)	Table Pos (deg)	Remark
2412	102.88	-	-	99.65	32.89	3.61	33.27	100	342	Peak
2412	96.96	-	-	93.73	32.89	3.61	33.27	100	342	Average
4826	50.14	-23.86	74	43.52	35.17	5.25	33.8	110	120	Peak



Test Mode :	802.11b	Temperature :	23~24°C
Test Channel :	06	Relative Humidity :	43~44%
Test Engineer :	Stone Gu	Polarization :	Horizontal
Remark :	1. 2437 MHz is fundamental signal which can be ignored. 2. Average measurement was not performed if peak level went lower than the average limit.		

Frequency (MHz)	Level (dBμV/m)	Over Limit (dB)	Limit Line (dBμV/m)	Read Level (dBμV)	Antenna Factor (dB)	Cable Loss (dB)	Preamp Factor (dB)	Ant Pos (cm)	Table Pos (deg)	Remark
2437	106.99	-	-	103.69	32.95	3.63	33.28	127	335	Peak
2437	100.79	-	-	97.49	32.95	3.63	33.28	127	335	Average
4874	47.24	-26.76	74	40.58	35.18	5.28	33.8	100	0	Peak
7312	49.73	-24.27	74	41.05	36.2	6.61	34.13	200	103	Peak

Test Mode :	802.11b	Temperature :	23~24°C
Test Channel :	06	Relative Humidity :	43~44%
Test Engineer :	Stone Gu	Polarization :	Vertical
Remark :	1. 2437 MHz is fundamental signal which can be ignored. 2. Average measurement was not performed if peak level went lower than the average limit.		

Frequency (MHz)	Level (dBμV/m)	Over Limit (dB)	Limit Line (dBμV/m)	Read Level (dBμV)	Antenna Factor (dB)	Cable Loss (dB)	Preamp Factor (dB)	Ant Pos (cm)	Table Pos (deg)	Remark
2437	101.94	-	-	98.64	32.95	3.63	33.28	100	311	Peak
2437	95.19	-	-	91.89	32.95	3.63	33.28	100	311	Average
4874	47.96	-26.04	74	41.3	35.18	5.28	33.8	120	0	Peak
7312	48.93	-25.07	74	40.25	36.2	6.61	34.13	120	0	Peak



Test Mode :	802.11b	Temperature :	23~24°C
Test Channel :	11	Relative Humidity :	43~44%
Test Engineer :	Stone Gu	Polarization :	Horizontal
Remark :	1. 2462 MHz is fundamental signal which can be ignored. 2. Average measurement was not performed if peak level went lower than the average limit.		

Frequency (MHz)	Level (dBμV/m)	Over Limit (dB)	Limit Line (dBμV/m)	Read Level (dBμV)	Antenna Factor (dB)	Cable Loss (dB)	Preamp Factor (dB)	Ant Pos (cm)	Table Pos (deg)	Remark
2462	107.04	-	-	103.71	32.98	3.64	33.29	100	335	Peak
2462	100.73	-	-	97.4	32.98	3.64	33.29	100	335	Average
4924	46.93	-27.07	74	40.23	35.19	5.31	33.8	200	0	Peak
7386	49.11	-24.89	74	40.33	36.24	6.7	34.16	100	320	Peak

Test Mode :	802.11b	Temperature :	23~24°C
Test Channel :	11	Relative Humidity :	43~44%
Test Engineer :	Stone Gu	Polarization :	Vertical
Remark :	1. 2462 MHz is fundamental signal which can be ignored. 2. Average measurement was not performed if peak level went lower than the average limit.		

Frequency (MHz)	Level (dBμV/m)	Over Limit (dB)	Limit Line (dBμV/m)	Read Level (dBμV)	Antenna Factor (dB)	Cable Loss (dB)	Preamp Factor (dB)	Ant Pos (cm)	Table Pos (deg)	Remark
2462	100.86	-	-	97.53	32.98	3.64	33.29	120	340	Peak
2462	94.89	-	-	91.56	32.98	3.64	33.29	120	340	Average
4924	46.35	-27.65	74	39.65	35.19	5.31	33.8	100	210	Peak
7386	48.62	-25.38	74	39.84	36.24	6.7	34.16	100	0	Peak



Test Mode :	802.11g	Temperature :	23~24°C
Test Channel :	01	Relative Humidity :	43~44%
Test Engineer :	Stone Gu	Polarization :	Horizontal
Remark :	1. 2412 MHz is fundamental signal which can be ignored. 2. Average measurement was not performed if peak level went lower than the average limit.		

Frequency (MHz)	Level (dBμV/m)	Over Limit (dB)	Limit Line (dBμV/m)	Read Level (dBμV)	Antenna Factor (dB)	Cable Loss (dB)	Preamp Factor (dB)	Ant Pos (cm)	Table Pos (deg)	Remark
2412	106.78	-	-	103.55	32.89	3.61	33.27	187	169	Peak
2412	96.06	-	-	92.83	32.89	3.61	33.27	187	169	Average
4824	45.86	-28.14	74	39.24	35.17	5.25	33.8	120	10	Peak

Test Mode :	802.11g	Temperature :	23~24°C
Test Channel :	01	Relative Humidity :	43~44%
Test Engineer :	Stone Gu	Polarization :	Vertical
Remark :	1. 2412 MHz is fundamental signal which can be ignored. 2. Average measurement was not performed if peak level went lower than the average limit.		

Frequency (MHz)	Level (dBμV/m)	Over Limit (dB)	Limit Line (dBμV/m)	Read Level (dBμV)	Antenna Factor (dB)	Cable Loss (dB)	Preamp Factor (dB)	Ant Pos (cm)	Table Pos (deg)	Remark
2412	101.99	-	-	98.76	32.89	3.61	33.27	100	335	Peak
2412	91.62	-	-	88.39	32.89	3.61	33.27	100	335	Average
4824	46.14	-27.86	74	39.52	35.17	5.25	33.8	200	0	Peak



Test Mode :	802.11g	Temperature :	23~24°C
Test Channel :	06	Relative Humidity :	43~44%
Test Engineer :	Stone Gu	Polarization :	Horizontal
Remark :	1. 2437 MHz is fundamental signal which can be ignored. 2. Average measurement was not performed if peak level went lower than the average limit.		

Frequency (MHz)	Level (dBμV/m)	Over Limit (dB)	Limit Line (dBμV/m)	Read Level (dBμV)	Antenna Factor (dB)	Cable Loss (dB)	Preamp Factor (dB)	Ant Pos (cm)	Table Pos (deg)	Remark
2437	105.78	-	-	102.48	32.95	3.63	33.28	100	332	Peak
2437	95.07	-	-	91.77	32.95	3.63	33.28	100	332	Average
4874	47.48	-26.52	74	40.82	35.18	5.28	33.8	200	301	Peak
7312	48.46	-25.54	74	39.78	36.2	6.61	34.13	100	0	Peak

Test Mode :	802.11g	Temperature :	23~24°C
Test Channel :	06	Relative Humidity :	43~44%
Test Engineer :	Stone Gu	Polarization :	Vertical
Remark :	1. 2437 MHz is fundamental signal which can be ignored. 2. Average measurement was not performed if peak level went lower than the average limit.		

Frequency (MHz)	Level (dBμV/m)	Over Limit (dB)	Limit Line (dBμV/m)	Read Level (dBμV)	Antenna Factor (dB)	Cable Loss (dB)	Preamp Factor (dB)	Ant Pos (cm)	Table Pos (deg)	Remark
2437	100.93	-	-	97.63	32.95	3.63	33.28	100	339	Peak
2437	90.24	-	-	86.94	32.95	3.63	33.28	100	339	Average
4874	47.59	-26.41	74	40.93	35.18	5.28	33.8	100	320	Peak
7312	49.11	-24.89	74	40.43	36.2	6.61	34.13	100	0	Peak



Test Mode :	802.11g	Temperature :	23~24°C
Test Channel :	11	Relative Humidity :	43~44%
Test Engineer :	Stone Gu	Polarization :	Horizontal
Remark :	1. 2462 MHz is fundamental signal which can be ignored. 2. Average measurement was not performed if peak level went lower than the average limit.		

Frequency (MHz)	Level (dBμV/m)	Over Limit (dB)	Limit Line (dBμV/m)	Read Level (dBμV)	Antenna Factor (dB)	Cable Loss (dB)	Preamp Factor (dB)	Ant Pos (cm)	Table Pos (deg)	Remark
43.58	27.14	-12.86	40	50.11	10.03	0.62	33.62	200	0	Peak
151.25	23.2	-20.3	43.5	45.7	9.96	1.12	33.58	-	-	Peak
343.31	25.88	-20.12	46	43.19	14.35	1.7	33.36	-	-	Peak
551.86	21.58	-24.42	46	33.99	18.5	2.1	33.01	-	-	Peak
875.84	22.9	-23.1	46	32.31	20.48	2.68	32.57	-	-	Peak
945.68	28.72	-17.28	46	37.64	20.71	2.81	32.44	-	-	Peak
2462	105.01	-	-	101.68	32.98	3.64	33.29	100	234	Peak
2462	94	-	-	90.67	32.98	3.64	33.29	100	234	Average
4924	47.21	-26.79	74	40.51	35.19	5.31	33.8	100	300	Peak
7386	49	-25	74	40.22	36.24	6.7	34.16	100	201	Peak



Test Mode :	802.11g	Temperature :	23~24°C
Test Channel :	11	Relative Humidity :	43~44%
Test Engineer :	Stone Gu	Polarization :	Vertical
Remark :	1. 2462 MHz is fundamental signal which can be ignored. 2. Average measurement was not performed if peak level went lower than the average limit.		

Frequency (MHz)	Level (dBμV/m)	Over Limit (dB)	Limit Line (dBμV/m)	Read Level (dBμV)	Antenna Factor (dB)	Cable Loss (dB)	Preamp Factor (dB)	Ant Pos (cm)	Table Pos (deg)	Remark
48.43	34.5	-5.5	40	59.32	8.12	0.65	33.59	100	0	Peak
128.94	26.77	-16.73	43.5	47.61	11.71	1.04	33.59	-	-	Peak
343.31	23.53	-22.47	46	40.84	14.35	1.7	33.36	-	-	Peak
550.89	22.81	-23.19	46	35.22	18.5	2.1	33.01	-	-	Peak
909.79	29.16	-16.84	46	38.35	20.49	2.75	32.43	-	-	Peak
945.68	28.2	-17.8	46	37.12	20.71	2.81	32.44	-	-	Peak
2462	101.83	-	-	98.5	32.98	3.64	33.29	175	188	Peak
2462	91.3	-	-	87.97	32.98	3.64	33.29	175	188	Average
4924	47.24	-26.76	74	40.54	35.19	5.31	33.8	200	0	Peak
7386	48.72	-25.28	74	39.94	36.24	6.7	34.16	100	300	Peak



Test Mode :	2.4GHz 802.11n HT20	Temperature :	23~24°C
Test Channel :	01	Relative Humidity :	43~44%
Test Engineer :	Stone Gu	Polarization :	Horizontal
Remark :	1. 2412 MHz is fundamental signal which can be ignored. 2. Average measurement was not performed if peak level went lower than the average limit.		

Frequency (MHz)	Level (dBμV/m)	Over Limit (dB)	Limit Line (dBμV/m)	Read Level (dBμV)	Antenna Factor (dB)	Cable Loss (dB)	Preamp Factor (dB)	Ant Pos (cm)	Table Pos (deg)	Remark
2412	102.79	-	-	99.56	32.89	3.61	33.27	100	330	Peak
2412	91.24	-	-	88.01	32.89	3.61	33.27	100	330	Average
4824	46.81	-27.19	74	40.19	35.17	5.25	33.8	100	0	Peak

Test Mode :	2.4GHz 802.11n HT20	Temperature :	23~24°C
Test Channel :	01	Relative Humidity :	43~44%
Test Engineer :	Stone Gu	Polarization :	Vertical
Remark :	1. 2412 MHz is fundamental signal which can be ignored. 2. Average measurement was not performed if peak level went lower than the average limit.		

Frequency (MHz)	Level (dBμV/m)	Over Limit (dB)	Limit Line (dBμV/m)	Read Level (dBμV)	Antenna Factor (dB)	Cable Loss (dB)	Preamp Factor (dB)	Ant Pos (cm)	Table Pos (deg)	Remark
2412	99.98	-	-	96.75	32.89	3.61	33.27	100	347	Peak
2412	88.17	-	-	84.94	32.89	3.61	33.27	100	347	Average
4824	46.54	-27.46	74	39.92	35.17	5.25	33.8	200	103	Peak



Test Mode :	2.4GHz 802.11n HT20	Temperature :	23~24°C
Test Channel :	06	Relative Humidity :	43~44%
Test Engineer :	Stone Gu	Polarization :	Horizontal
Remark :	1. 2437 MHz is fundamental signal which can be ignored. 2. Average measurement was not performed if peak level went lower than the average limit.		

Frequency (MHz)	Level (dBμV/m)	Over Limit (dB)	Limit Line (dBμV/m)	Read Level (dBμV)	Antenna Factor (dB)	Cable Loss (dB)	Preamp Factor (dB)	Ant Pos (cm)	Table Pos (deg)	Remark
2437	103.81	-	-	100.51	32.95	3.63	33.28	152	340	Peak
2437	92.58	-	-	89.28	32.95	3.63	33.28	152	340	Average
4874	47.44	-26.56	74	40.78	35.18	5.28	33.8	100	0	Peak
7312	48.43	-25.57	74	39.75	36.2	6.61	34.13	200	0	Peak

Test Mode :	2.4GHz 802.11n HT20	Temperature :	23~24°C
Test Channel :	06	Relative Humidity :	43~44%
Test Engineer :	Stone Gu	Polarization :	Vertical
Remark :	1. 2437 MHz is fundamental signal which can be ignored. 2. Average measurement was not performed if peak level went lower than the average limit.		

Frequency (MHz)	Level (dBμV/m)	Over Limit (dB)	Limit Line (dBμV/m)	Read Level (dBμV)	Antenna Factor (dB)	Cable Loss (dB)	Preamp Factor (dB)	Ant Pos (cm)	Table Pos (deg)	Remark
2437	99.08	-	-	95.78	32.95	3.63	33.28	100	338	Peak
2437	87.37	-	-	84.07	32.95	3.63	33.28	100	338	Average
4874	49.22	-24.78	74	42.56	35.18	5.28	33.8	200	310	Peak
7312	48.68	-25.32	74	40	36.2	6.61	34.13	100	0	Peak



Test Mode :	2.4GHz 802.11n HT20	Temperature :	23~24°C
Test Channel :	11	Relative Humidity :	43~44%
Test Engineer :	Stone Gu	Polarization :	Horizontal
Remark :	1. 2462 MHz is fundamental signal which can be ignored. 2. Average measurement was not performed if peak level went lower than the average limit.		

Frequency (MHz)	Level (dBμV/m)	Over Limit (dB)	Limit Line (dBμV/m)	Read Level (dBμV)	Antenna Factor (dB)	Cable Loss (dB)	Preamp Factor (dB)	Ant Pos (cm)	Table Pos (deg)	Remark
2462	102.71	-	-	99.38	32.98	3.64	33.29	100	227	Peak
2462	91.54	-	-	88.21	32.98	3.64	33.29	100	227	Average
4924	48.25	-25.75	74	41.55	35.19	5.31	33.8	100	201	Peak
7386	48.67	-25.33	74	39.89	36.24	6.7	34.16	200	0	Peak

Test Mode :	2.4GHz 802.11n HT20	Temperature :	23~24°C
Test Channel :	11	Relative Humidity :	43~44%
Test Engineer :	Stone Gu	Polarization :	Vertical
Remark :	1. 2462 MHz is fundamental signal which can be ignored. 2. Average measurement was not performed if peak level went lower than the average limit.		

Frequency (MHz)	Level (dBμV/m)	Over Limit (dB)	Limit Line (dBμV/m)	Read Level (dBμV)	Antenna Factor (dB)	Cable Loss (dB)	Preamp Factor (dB)	Ant Pos (cm)	Table Pos (deg)	Remark
2462	99.22	-	-	95.89	32.98	3.64	33.29	119	211	Peak
2462	87.58	-	-	84.25	32.98	3.64	33.29	119	211	Average
4924	47.65	-26.35	74	40.95	35.19	5.31	33.8	200	0	Peak
7386	49.01	-24.99	74	40.23	36.24	6.7	34.16	100	0	Peak



Test Mode :	2.4GHz 802.11n HT40	Temperature :	23~24°C
Test Channel :	03	Relative Humidity :	43~44%
Test Engineer :	Stone Gu	Polarization :	Horizontal
Remark :	1. 2422 MHz is fundamental signal which can be ignored. 2. Average measurement was not performed if peak level went lower than the average limit.		

Frequency (MHz)	Level (dBμV/m)	Over Limit (dB)	Limit Line (dBμV/m)	Read Level (dBμV)	Antenna Factor (dB)	Cable Loss (dB)	Preamp Factor (dB)	Ant Pos (cm)	Table Pos (deg)	Remark
2422	98.17	-	-	94.91	32.92	3.62	33.28	100	228	Peak
2422	88.13	-	-	84.87	32.92	3.62	33.28	100	228	Average
4844	46.14	-27.86	74	39.5	35.18	5.26	33.8	120	0	Peak
7266	48.75	-25.25	74	40.11	36.19	6.56	34.11	100	0	Peak

Test Mode :	2.4GHz 802.11n HT40	Temperature :	23~24°C
Test Channel :	03	Relative Humidity :	43~44%
Test Engineer :	Stone Gu	Polarization :	Vertical
Remark :	1. 2422 MHz is fundamental signal which can be ignored. 2. Average measurement was not performed if peak level went lower than the average limit.		

Frequency (MHz)	Level (dBμV/m)	Over Limit (dB)	Limit Line (dBμV/m)	Read Level (dBμV)	Antenna Factor (dB)	Cable Loss (dB)	Preamp Factor (dB)	Ant Pos (cm)	Table Pos (deg)	Remark
2422	96	-	-	92.74	32.92	3.62	33.28	100	257	Peak
2422	85.91	-	-	82.65	32.92	3.62	33.28	100	257	Average
4844	46.02	-27.98	74	39.38	35.18	5.26	33.8	100	320	Peak
7266	48.67	-25.33	74	40.03	36.19	6.56	34.11	100	0	Peak



Test Mode :	2.4GHz 802.11n HT40	Temperature :	23~24°C
Test Channel :	06	Relative Humidity :	43~44%
Test Engineer :	Stone Gu	Polarization :	Horizontal
Remark :	1. 2437 MHz is fundamental signal which can be ignored. 2. Average measurement was not performed if peak level went lower than the average limit.		

Frequency (MHz)	Level (dBμV/m)	Over Limit (dB)	Limit Line (dBμV/m)	Read Level (dBμV)	Antenna Factor (dB)	Cable Loss (dB)	Preamp Factor (dB)	Ant Pos (cm)	Table Pos (deg)	Remark
2437	99.77	-	-	96.47	32.95	3.63	33.28	100	338	Peak
2437	88.82	-	-	85.52	32.95	3.63	33.28	100	338	Average
4874	46.51	-27.49	74	39.85	35.18	5.28	33.8	120	300	Peak
7312	49.74	-24.26	74	41.06	36.2	6.61	34.13	100	0	Peak

Test Mode :	2.4GHz 802.11n HT40	Temperature :	23~24°C
Test Channel :	06	Relative Humidity :	43~44%
Test Engineer :	Stone Gu	Polarization :	Vertical
Remark :	1. 2437 MHz is fundamental signal which can be ignored. 2. Average measurement was not performed if peak level went lower than the average limit.		

Frequency (MHz)	Level (dBμV/m)	Over Limit (dB)	Limit Line (dBμV/m)	Read Level (dBμV)	Antenna Factor (dB)	Cable Loss (dB)	Preamp Factor (dB)	Ant Pos (cm)	Table Pos (deg)	Remark
2437	94.11	-	-	90.81	32.95	3.63	33.28	100	343	Peak
2437	84.05	-	-	80.75	32.95	3.63	33.28	100	343	Average
4874	48.42	-25.58	74	41.76	35.18	5.28	33.8	100	0	Peak
7312	48.89	-25.11	74	40.21	36.2	6.61	34.13	100	0	Peak



Test Mode :	2.4GHz 802.11n HT40	Temperature :	23~24°C
Test Channel :	09	Relative Humidity :	43~44%
Test Engineer :	Stone Gu	Polarization :	Horizontal
Remark :	1. 2452 MHz is fundamental signal which can be ignored. 2. Average measurement was not performed if peak level went lower than the average limit.		

Frequency (MHz)	Level (dBμV/m)	Over Limit (dB)	Limit Line (dBμV/m)	Read Level (dBμV)	Antenna Factor (dB)	Cable Loss (dB)	Preamp Factor (dB)	Ant Pos (cm)	Table Pos (deg)	Remark
2452	99.03	-	-	95.73	32.95	3.63	33.28	154	338	Peak
2452	88.69	-	-	85.39	32.95	3.63	33.28	154	338	Average
4904	46.07	-27.93	74	39.38	35.19	5.3	33.8	200	0	Peak
7356	48.96	-25.04	74	40.23	36.22	6.66	34.15	100	0	Peak

Test Mode :	2.4GHz 802.11n HT40	Temperature :	23~24°C
Test Channel :	09	Relative Humidity :	43~44%
Test Engineer :	Stone Gu	Polarization :	Vertical
Remark :	1. 2452 MHz is fundamental signal which can be ignored. 2. Average measurement was not performed if peak level went lower than the average limit.		

Frequency (MHz)	Level (dBμV/m)	Over Limit (dB)	Limit Line (dBμV/m)	Read Level (dBμV)	Antenna Factor (dB)	Cable Loss (dB)	Preamp Factor (dB)	Ant Pos (cm)	Table Pos (deg)	Remark
2452	96.89	-	-	93.59	32.95	3.63	33.28	147	210	Peak
2452	85.21	-	-	81.91	32.95	3.63	33.28	147	210	Average
4904	46.51	-27.49	74	39.82	35.19	5.3	33.8	200	0	Peak
7356	49.3	-24.7	74	40.57	36.22	6.66	34.15	200	0	Peak

3.6 AC Conducted Emission Measurement

3.6.1 Limit of AC Conducted Emission

For equipment that is designed to be connected to the public utility (AC) power line, the radio frequency voltage that is conducted back onto the AC power line on any frequency or frequencies within the band 150 kHz to 30 MHz shall not exceed the limits in the following table.

Frequency of Emission (MHz)	Conducted Limit (dB μ V)	
	Quasi-Peak	Average
0.15-0.5	66 to 56*	56 to 46*
0.5-5	56	46
5-30	60	50

*Decreases with the logarithm of the frequency.

3.6.2 Measuring Instruments

The measuring equipment is listed in the section 4 of this test report.

3.6.3 Test Procedures

1. The EUT was placed 0.4 meter from the conducting wall of the shielding room, and it was kept at least 80 centimeters from any other grounded conducting surface.
2. Connect EUT to the power mains through a line impedance stabilization network (LISN).
3. All the support units are connecting to the other LISN.
4. The LISN provides 50 ohm coupling impedance for the measuring instrument.
5. The FCC states that a 50 ohm, 50 microhenry LISN should be used.
6. Both sides of AC line were checked for maximum conducted interference.
7. The frequency range from 150 kHz to 30 MHz was searched.
8. Set the test-receiver system to Peak Detect Function and specified bandwidth with Maximum Hold Mode.

3.6.4 Test Setup

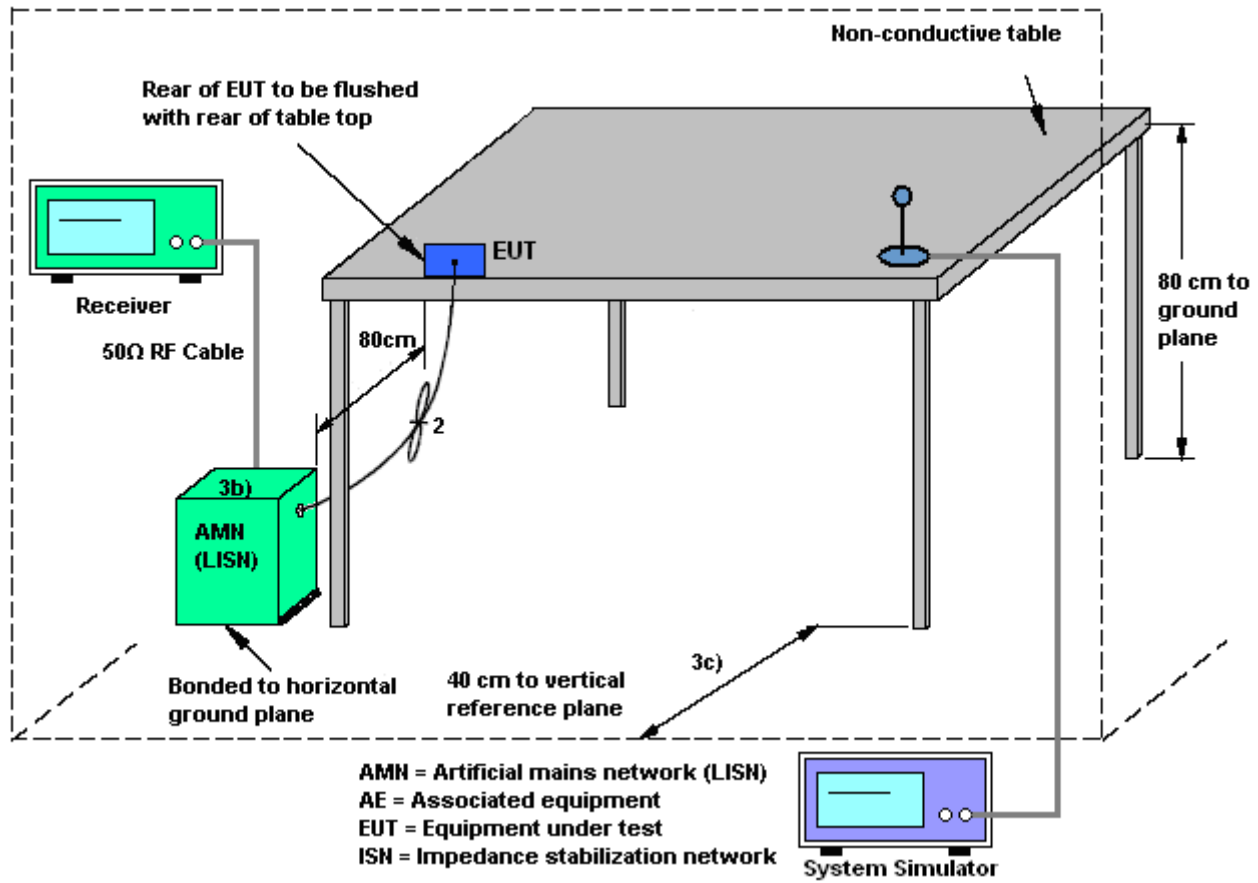



3.6.5 Test Result of AC Conducted Emission

Test Mode :	Mode 1	Temperature :	21~23°C
Test Engineer :	Eligah Wang	Relative Humidity :	37~39%
Test Voltage :	120Vac / 60Hz	Phase :	Line
Function Type :	GSM850 Idle + Bluetooth Link + WLAN Link + USB Cable (Charging from Adapter) + Earphone		

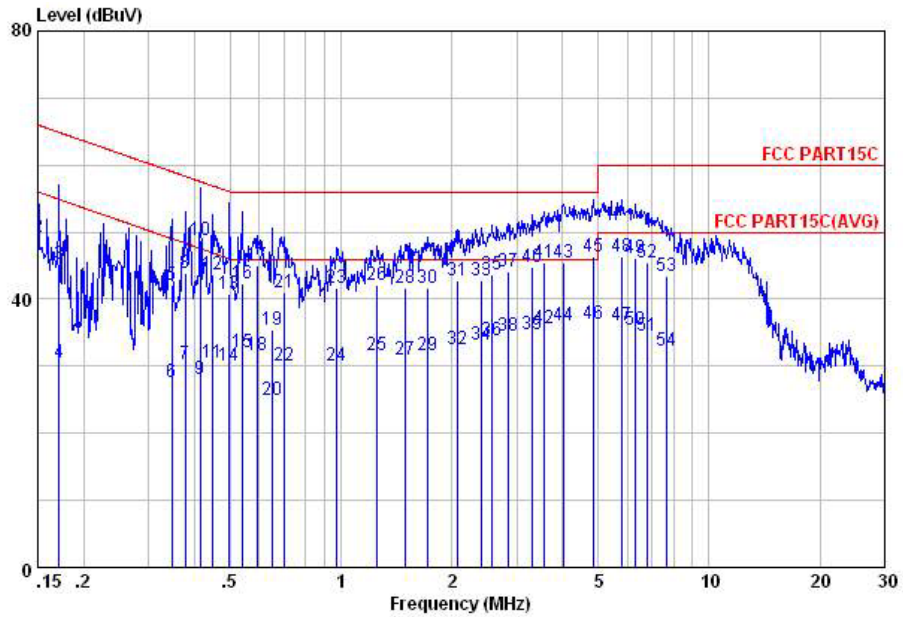

Site : C001-KS
 Condition: FCC PART15C LISN-L20130306 LINE

	Freq	Level	Over	Limit	Read	LISN	Cable	Remark
	MHz	dBuV	dB	dBuV	dBuV	dB	dB	
1	0.15	35.47	-20.53	56.00	22.80	1.95	10.72	Average
2	0.15	49.27	-16.73	66.00	36.60	1.95	10.72	QP
3	0.17	45.27	-19.63	64.90	33.10	1.53	10.64	QP
4	0.17	30.47	-24.43	54.90	18.30	1.53	10.64	Average
5	0.35	42.07	-16.98	59.05	31.30	0.45	10.32	QP
6	0.35	27.67	-21.38	49.05	16.90	0.45	10.32	Average
7	0.38	30.26	-18.08	48.34	19.60	0.36	10.30	Average
8	0.38	43.96	-14.38	58.34	33.30	0.36	10.30	QP
9	0.41	28.17	-19.38	47.55	17.60	0.29	10.28	Average
10	0.41	48.87	-8.68	57.55	38.30	0.29	10.28	QP
11	0.45	30.42	-16.47	46.89	19.90	0.25	10.27	Average
12	0.45	43.62	-13.27	56.89	33.10	0.25	10.27	QP
13	0.50	40.87	-15.18	56.05	30.41	0.20	10.26	QP
14	0.50	30.07	-15.98	46.05	19.61	0.20	10.26	Average
15	0.54	32.06	-13.94	46.00	21.60	0.20	10.26	Average
16	0.54	42.26	-13.74	56.00	31.80	0.20	10.26	QP
17	0.59	45.04	-10.96	56.00	34.60	0.20	10.24	QP
18	0.59	31.54	-14.46	46.00	21.10	0.20	10.24	Average
19	0.65	35.32	-20.68	56.00	24.90	0.20	10.22	QP
20	0.65	25.02	-20.98	46.00	14.60	0.20	10.22	Average
21	0.70	41.01	-14.99	56.00	30.60	0.20	10.21	QP
22	0.70	30.01	-15.99	46.00	19.60	0.20	10.21	Average
23	0.97	41.59	-14.41	56.00	31.31	0.10	10.18	QP
24	0.97	30.19	-15.81	46.00	19.91	0.10	10.18	Average
25	1.26	31.58	-14.42	46.00	21.30	0.10	10.18	Average
26	1.26	42.08	-13.92	56.00	31.80	0.10	10.18	QP
27	1.49	30.89	-15.11	46.00	20.60	0.10	10.19	Average
28	1.49	41.59	-14.41	56.00	31.30	0.10	10.19	QP



Test Mode :	Mode 1	Temperature :	21~23°C
Test Engineer :	Eligah Wang	Relative Humidity :	37~39%
Test Voltage :	120Vac / 60Hz	Phase :	Line
Function Type :	GSM850 Idle + Bluetooth Link + WLAN Link + USB Cable (Charging from Adapter) + Earphone		

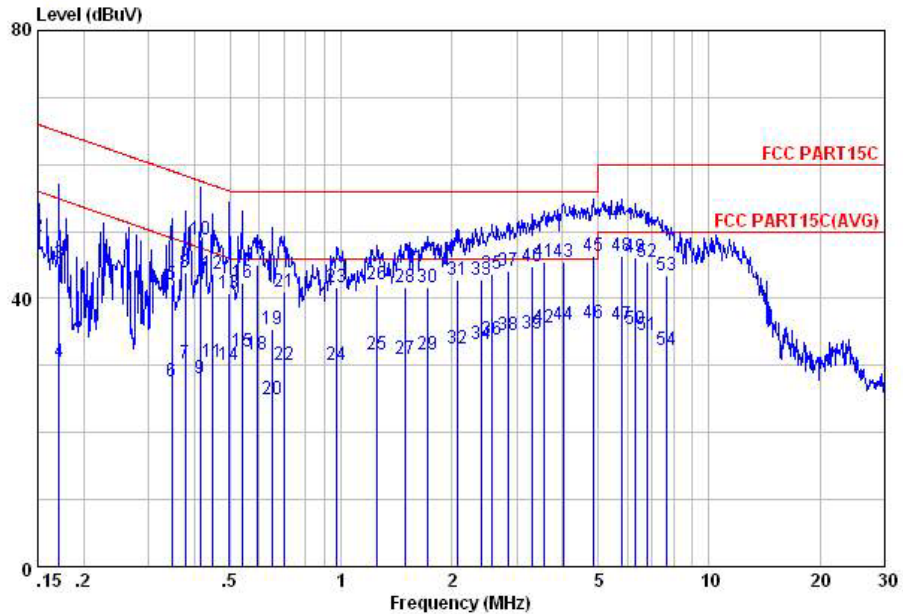

Site : C001-KS
 Condition: FCC PART15C LISN-L20130306 LINE

	Freq	Level	Over	Limit	Read	LISN	Cable	Remark
	MHz	dBuV	Limit	Line	Level	Factor	Loss	
		dBuV	dB	dBuV	dBuV	dB	dB	
29	1.73	31.59	-14.41	46.00	21.30	0.10	10.19	Average
30	1.73	41.59	-14.41	56.00	31.30	0.10	10.19	QP
31	2.08	42.69	-13.31	56.00	32.40	0.10	10.19	QP
32	2.08	32.59	-13.41	46.00	22.30	0.10	10.19	Average
33	2.41	42.71	-13.29	56.00	32.40	0.11	10.20	QP
34	2.41	33.21	-12.79	46.00	22.90	0.11	10.20	Average
35	2.58	43.72	-12.28	56.00	33.39	0.12	10.21	QP
36	2.58	33.92	-12.08	46.00	23.59	0.12	10.21	Average
37	2.84	44.14	-11.86	56.00	33.79	0.13	10.22	QP
38	2.84	34.64	-11.36	46.00	24.29	0.13	10.22	Average
39	3.31	34.69	-11.31	46.00	24.30	0.16	10.23	Average
40	3.31	44.69	-11.31	56.00	34.30	0.16	10.23	QP
41	3.57	45.51	-10.49	56.00	35.11	0.17	10.23	QP
42	3.57	35.71	-10.29	46.00	25.31	0.17	10.23	Average
43	4.01	45.52	-10.48	56.00	35.10	0.18	10.24	QP
44	4.01	36.02	-9.98	46.00	25.60	0.18	10.24	Average
45	4.85	46.35	-9.65	56.00	35.89	0.20	10.26	QP
46	4.85	36.35	-9.65	46.00	25.89	0.20	10.26	Average
47	5.80	36.08	-13.92	50.00	25.60	0.20	10.28	Average
48	5.80	46.38	-13.62	60.00	35.90	0.20	10.28	QP
49	6.32	46.10	-13.90	60.00	35.60	0.20	10.30	QP
50	6.32	35.40	-14.60	50.00	24.90	0.20	10.30	Average
51	6.81	34.62	-15.38	50.00	24.10	0.20	10.32	Average
52	6.81	45.42	-14.58	60.00	34.90	0.20	10.32	QP
53	7.65	43.43	-16.57	60.00	32.90	0.20	10.33	QP
54	7.65	32.33	-17.67	50.00	21.80	0.20	10.33	Average



Test Mode :	Mode 1	Temperature :	21~23°C
Test Engineer :	Eligah Wang	Relative Humidity :	37~39%
Test Voltage :	120Vac / 60Hz	Phase :	Neutral
Function Type :	GSM850 Idle + Bluetooth Link + WLAN Link + USB Cable (Charging from Adapter) + Earphone		

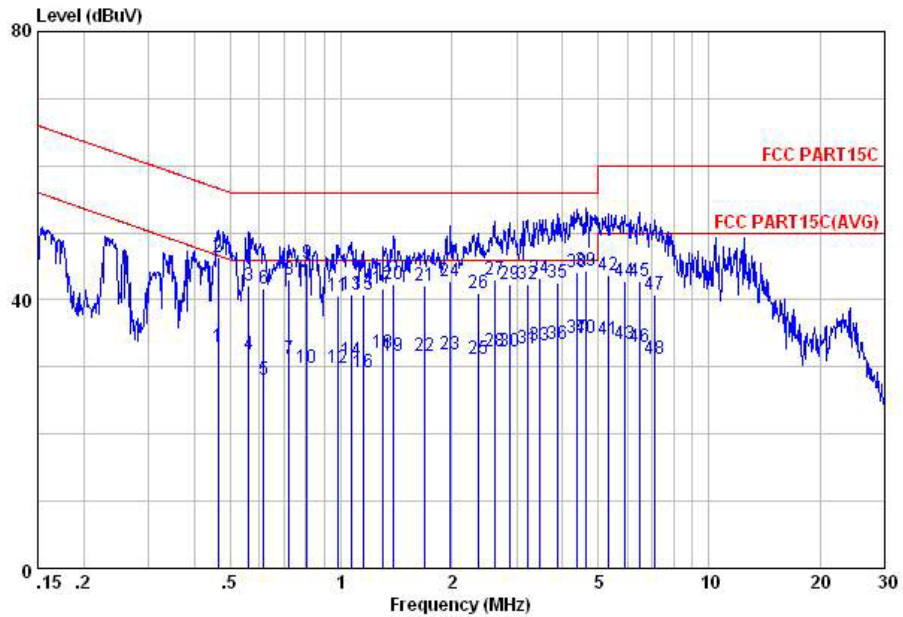

Site : C001-KS
 Condition: FCC PART15C LISM-N20130306 NEUTRAL

	Freq	Level	Over	Limit	Read	LISM	Cable	Remark
	MHz	dBuV	Limit	Line	Level	Factor	Loss	
			dB	dBuV	dBuV	dB	dB	
1	0.46	32.90	-13.73	46.63	22.30	0.33	10.27	Average
2	0.46	46.40	-10.23	56.63	35.80	0.33	10.27	QP
3	0.56	42.12	-13.88	56.00	31.60	0.27	10.25	QP
4	0.56	31.82	-14.18	46.00	21.30	0.27	10.25	Average
5	0.62	28.07	-17.93	46.00	17.60	0.23	10.24	Average
6	0.62	41.77	-14.23	56.00	31.30	0.23	10.24	QP
7	0.72	31.30	-14.70	46.00	20.90	0.19	10.21	Average
8	0.72	43.00	-13.00	56.00	32.60	0.19	10.21	QP
9	0.81	45.46	-10.54	56.00	35.10	0.16	10.20	QP
10	0.81	29.96	-16.04	46.00	19.60	0.16	10.20	Average
11	0.98	40.59	-15.41	56.00	30.31	0.10	10.18	QP
12	0.98	29.89	-16.11	46.00	19.61	0.10	10.18	Average
13	1.07	40.88	-15.12	56.00	30.60	0.10	10.18	QP
14	1.07	30.88	-15.12	46.00	20.60	0.10	10.18	Average
15	1.15	40.88	-15.12	56.00	30.60	0.10	10.18	QP
16	1.15	29.18	-16.82	46.00	18.90	0.10	10.18	Average
17	1.30	41.68	-14.32	56.00	31.40	0.10	10.18	QP
18	1.30	32.08	-13.92	46.00	21.80	0.10	10.18	Average
19	1.39	31.58	-14.42	46.00	21.30	0.10	10.18	Average
20	1.39	42.38	-13.62	56.00	32.10	0.10	10.18	QP
21	1.68	42.09	-13.91	56.00	31.80	0.10	10.19	QP
22	1.68	31.69	-14.31	46.00	21.40	0.10	10.19	Average
23	1.98	31.89	-14.11	46.00	21.60	0.10	10.19	Average
24	1.98	42.89	-13.11	56.00	32.60	0.10	10.19	QP
25	2.37	31.21	-14.79	46.00	20.90	0.11	10.20	Average
26	2.37	41.11	-14.89	56.00	30.80	0.11	10.20	QP
27	2.61	42.92	-13.08	56.00	32.59	0.12	10.21	QP
28	2.61	32.22	-13.78	46.00	21.89	0.12	10.21	Average



Test Mode :	Mode 1	Temperature :	21~23°C
Test Engineer :	Eligah Wang	Relative Humidity :	37~39%
Test Voltage :	120Vac / 60Hz	Phase :	Neutral
Function Type :	GSM850 Idle + Bluetooth Link + WLAN Link + USB Cable (Charging from Adapter) + Earphone		

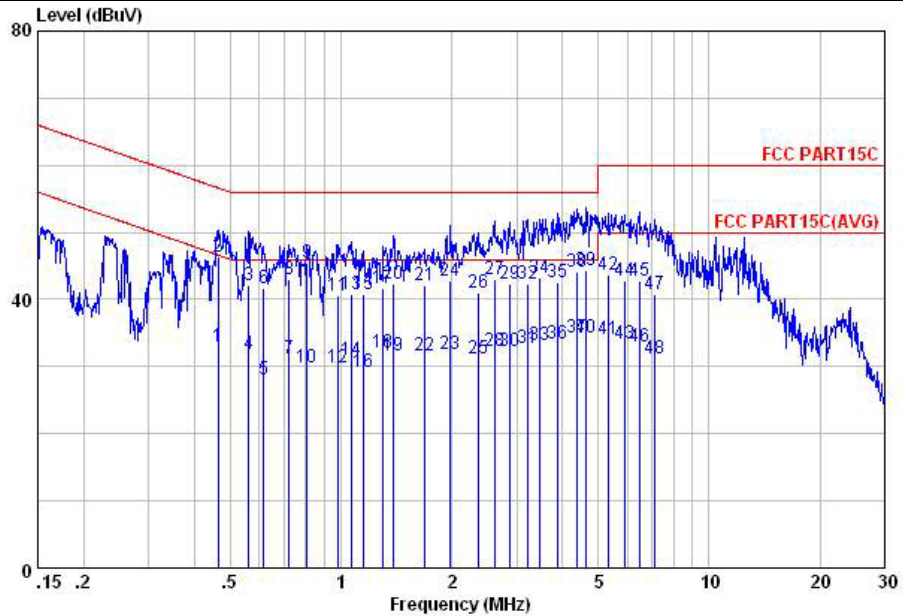

Site : C001-KS
 Condition: FCC PART15C LISM-M20130306 NEUTRAL

	Freq	Level	Over	Limit	Read	LISM	Cable	Remark
	MHz	dBuV	Limit	Line	Level	Factor	Loss	
			dB	dBuV	dBuV	dB	dB	
29	2.87	42.25	-13.75	56.00	31.90	0.13	10.22	QP
30	2.87	32.25	-13.75	46.00	21.90	0.13	10.22	Average
31	3.21	32.78	-13.22	46.00	22.40	0.15	10.23	Average
32	3.21	42.28	-13.72	56.00	31.90	0.15	10.23	QP
33	3.45	33.30	-12.70	46.00	22.90	0.17	10.23	Average
34	3.45	43.20	-12.80	56.00	32.80	0.17	10.23	QP
35	3.86	42.52	-13.48	56.00	32.10	0.18	10.24	QP
36	3.86	33.52	-12.48	46.00	23.10	0.18	10.24	Average
37	4.38	34.34	-11.66	46.00	23.90	0.19	10.25	Average
38	4.38	44.04	-11.96	56.00	33.60	0.19	10.25	QP
39	4.65	44.25	-11.75	56.00	33.80	0.20	10.25	QP
40	4.65	34.25	-11.75	46.00	23.80	0.20	10.25	Average
41	5.33	34.07	-15.93	50.00	23.60	0.20	10.27	Average
42	5.33	43.57	-16.43	60.00	33.10	0.20	10.27	QP
43	5.90	33.38	-16.62	50.00	22.90	0.20	10.28	Average
44	5.90	42.78	-17.22	60.00	32.30	0.20	10.28	QP
45	6.45	42.81	-17.19	60.00	32.30	0.20	10.31	QP
46	6.45	32.91	-17.09	50.00	22.40	0.20	10.31	Average
47	7.14	40.82	-19.18	60.00	30.30	0.20	10.32	QP
48	7.14	31.22	-18.78	50.00	20.70	0.20	10.32	Average



3.7 Antenna Requirements

3.7.1 Standard Applicable

If directional gain of transmitting antennas is greater than 6dBi, the power shall be reduced by the same level in dB comparing to gain minus 6dBi. For the fixed point-to-point operation, the power shall be reduced by one dB for every 3 dB that the directional gain of the antenna exceeds 6 dBi. The use of a permanently attached antenna or of an antenna that uses a unique coupling to the intentional radiator shall be considered sufficient to comply with the FCC rule.

3.7.2 Antenna Anti-Replacement Construction

An embedded-in antenna design is used.

3.7.3 Antenna Gain

The antenna peak gain of EUT is less than 6 dBi. Therefore, it is not necessary to reduce maximum peak output power limit.



4 List of Measuring Equipment

Instrument	Manufacturer	Model No.	Serial No.	Characteristics	Calibration Date	Test Date	Due Date	Remark
Spectrum Analyzer	R&S	FSP40	100319	9kHz~40GHz	Dec. 28, 2013	May 04, 2014~ May 14, 2014	Dec. 27, 2014	Conducted (TH01-KS)
Pulse Power Sensor	Anritsu	MA2411B	0917070	30MHz~40GHz	Feb. 27, 2014	May 04, 2014~ May 14, 2014	Feb. 26, 2015	Conducted (TH01-KS)
Power Meter	Anritsu	ML2495A	1005002	50MHz Bandwidth	Feb. 27, 2014	May 04, 2014~ May 14, 2014	Feb. 26, 2015	Conducted (TH01-KS)
EMI Test Receiver	R&S	ESCI	100534	9kHz~3GHz	Nov. 05, 2013	May 15, 2014	Nov. 04, 2014	Radiation (03CH01-KS)
Spectrum Analyzer	R&S	FSP30	101399	9kHz~30GHz	May 23, 2013	May 15, 2014	May 22, 2014	Radiation (03CH01-KS)
Loop Antenna	R&S	HFH2-Z2	100321	9kHz~30MHz	Oct. 09, 2013	May 15, 2014	Oct. 08, 2014	Radiation (03CH01-KS)
Bilog Antenna	SCHAFFNER	CBL6112D	23182	25MHz~2GHz	Jan. 08, 2014	May 15, 2014	Jan. 07, 2015	Radiation (03CH01-KS)
Double Ridge Horn Antenna	EMCO	3117	00075959	1GHz~18GHz	Jan. 08, 2014	May 15, 2014	Jan. 07, 2015	Radiation (03CH01-KS)
SHF-EHF Horn	Schwarzbeck	BBHA 9170	BBHA1702 49	15GHz~40GHz	Mar. 10, 2014	May 15, 2014	Mar. 09, 2015	Radiation (03CH01-KS)
Active Horn Antenna	com-power	AHA-118	701030	1GHz~18GHz	Nov. 18, 2013	May 15, 2014	Nov. 17, 2014	Radiation (03CH01-KS)
Amplifier	com-power	PA-103A	161073	1MHz~1GHz	May 04, 2014	May 15, 2014	May 03, 2015	Radiation (03CH01-KS)
Amplifier	Agilent	8449B	3008A023 71	1GHz~26.5GHz	Dec.10, 2013	May 15, 2014	Dec. 09, 2014	Radiation (03CH01-KS)
Turn Table	MF	MF7802	N/A	0~360 degree	NCR	May 15, 2014	NCR	Radiation (03CH01-KS)
Antenna Mast	MF	MF7802	N/A	1 m~4 m	NCR	May 15, 2014	NCR	Radiation (03CH01-KS)
EMI Receiver	R&S	ESCI7	100768	9kHz~7GHz	May 23, 2013	May 06, 2014	May 22, 2014	Conduction (CO01-KS)
AC LISN	MessTec	AN3016	060103	9kHz~30MHz	Dec. 10, 2013	May 06, 2014	Dec. 09, 2014	Conduction (CO01-KS)
AC LISN (for auxiliary equipment)	MessTec	AN3016	060105	9kHz~30MHz	Dec. 10, 2013	May 06, 2014	Dec. 09, 2014	Conduction (CO01-KS)
AC Power Source	Chroma	61602	ABP00000 0811	AC 0V~300V, 45Hz~1000Hz	Dec. 10, 2013	May 06, 2014	Dec. 09, 2014	Conduction (CO01-KS)



5 Uncertainty of Evaluation

Uncertainty of Conducted Emission Measurement (150kHz ~ 30MHz)

Measuring Uncertainty for a Level of Confidence of 95% ($U = 2Uc(y)$)	2.26
---	------

Uncertainty of Radiated Emission Measurement (30 MHz ~ 1000 MHz)

Measuring Uncertainty for a Level of Confidence of 95% ($U = 2Uc(y)$)	2.54
---	------