

EMI TEST REPORT

FCC CERTIFICATION

Applicant:

LG Electronics MobileComm U.S.A., Inc.
1000 Sylvan Avenue, Englewood Cliffs NJ 07632

Date of Receipt: October 18, 2016**Date of Issue: November 14, 2016****Test Report No. HCT-E-1611-F009****HCT FRN: 0005866421****FCC ID :****ZNFW280**

Rule Part(s) / Standard(s): FCC CFR 47 PART 15 Subpart B Class B
FCC Classification: JBP (Part 15 B – Class B Computing Device Peripheral)
EUT Type: Portable Wrist Device
Model Name: LG-W280
Additional Model Name(s): LGW280, W280, LG-W280A, LGW280A, W280A, LG-W280V, LGW280V, W280V
Date of Test: November 09, 2016 - November 10, 2016

The device bearing the trade name and model specified above, has been shown to comply with the applicable technical standards as indicated in the measurement report and was tested in accordance with the measurement procedures specified in ANSI C63.4-2014. (See Test Report if any modifications were made for compliance)

I attest to the accuracy of data. All measurements reported herein were performed by me or were made under my supervision and are correct to the best of my knowledge and belief. I assume full responsibility for the completeness of these measurements and vouch for the qualifications of all persons taking them.

HCT certifies that no party to application has been denied the FCC benefits pursuant to Section 5301 of the Anti-Drug Abuse Act of 1988, 21 U.S.C 862

Tested By

Jea-Woong Lee
Test Engineer
EMC Team
Certification Division

Reviewed By

Jin-Pyo Hong
Technical Manager
EMC Team
Certification Division

This report only responds to the tested sample and may not be reproduced, except in full, without written approval of the HCT Co., Ltd.



DOCUMENT HISTORY

The revision history for this document is shown in table.

Version	Date	Description
HCT-E-1611-F009	November 14, 2016	Initial Release



TABLE OF CONTENTS

	PAGE
1. GENERAL INFORMATION	4
1.1 Description of EUT	4
1.2 Related Submittal(s) / Grant(s).....	4
1.3 Test Facility	5
1.4 Calibration of Measuring Instrument	5
1.5 Tested System Details.....	6
1.6 Cable Description	7
1.7 Noise Suppression Parts on Cable. (I/O Cable)	7
2. MEASUREMENT UNCERTAINTY	8
3. DESCRIPTION OF TEST	9
3.1 Measurement of Conducted Emission.....	9
3.2 Measurement of Radiated Measurements	10
4. PRELIMINARY TEST	12
4.1 Conducted Emission Test	12
4. 2 Radiated Emission Test	12
5. CONDUCTED AND RADIATED EMISSION TEST SUMMARY	13
5.1 Conducted Emission Test	13
5.2 Radiated Emission Test	20
6. LIST OF TEST EQUIPMENT	22
7. CONCLUSION	23

ATTACHMENT: TEST SETUP PHOTOGRAPHS



1. GENERAL INFORMATION

1.1 Description of EUT

Its basic purpose is used for communications.

FCC ID	ZNFW280
Model	LG-W280
Additional Model(s)	LGW280, W280, LG-W280A, LGW280A, W280A, LG-W280V, LGW280V, W280V
EUT Type	Portable Wrist Device
TX Frequency	824.2 MHz to 848.8 MHz (GSM 850) 1 850.2 MHz to 1 909.8 MHz (GSM 1 900) 826.4 MHz to 846.6 MHz (WCDMA 850) 1 852.4 MHz to 1 907.6 MHz (WCDMA 1 900) 1712.4 MHz to 1752.6 MHz (WCDMA 1 700) 1 850 MHz to 1 910 MHz (LTE B2) 1 710 MHz to 1 755 MHz (LTE B4) 824 MHz to 849 MHz (LTE B5) 777 MHz to 787 MHz (LTE B13) 2 402 MHz to 2 480 MHz (Bluetooth) 2 412 MHz to 2 462 MHz (WiFi 2.4 GHz band)
RX Frequency	869.2 MHz to 893.8 MHz (GSM 850) 1 930.2 MHz to 1 989.8 MHz (GSM 1 900) 871.4 MHz to 891.6 MHz (WCDMA 850) 1 932.4 MHz to 1 987.6 MHz (WCDMA 1 900) 2 112.4 MHz to 2 152.6 MHz (WCDMA 1 700) 1 930 MHz to 1 990 MHz (LTE B2) 2 110 MHz to 2 155 MHz (LTE B4) 869 MHz to 894 MHz (LTE B5) 746 MHz to 756 MHz (LTE B13) 2 402 MHz to 2 480 MHz (Bluetooth) 2 412 MHz to 2 462 MHz (WiFi 2.4 GHz band) 13.56 MHz (NFC)

1.2 Related Submittal(s) / Grant(s)

Original submittal only.



1.3 Test Facility

Test site is located at 74, SEOICHEON-RO, 578BEON-GIL, MAJANG-MYEON, ICHEON-SI, GYEONGGI-DO, SOUTH KOREA. Those measurement facilities are constructed in conformance with the requirements of ANSI C63.4-2014.

Measurement Facilities	Registration Number
Radiated Field strength measurement facility (3 m)	90661 (July 07, 2015)
Radiated Field strength measurement facility (10 m)	90661 (July 07, 2015)

1.4 Calibration of Measuring Instrument

The measuring equipment, which was utilized in performing the tests documented herein, has been calibrated in accordance with the manufacturers recommendations for utilizing calibration equipments, which is traceable to recognized national standards.

Especially, all antenna for measurement is calibrated in accordance with the requirements of C63.5 (Version : 2006).



1.5 Tested System Details

All equipment descriptions used in the tested system (including inserted cards) are:

Device Type	Model Name	Manufacturer	FCC ID / DoC	Connected To
EUT	LG-W280	LG	ZNFW280	Wireless charging PAD
USB cable	EAD63849205	Ningbo Broad	-	Wireless charging PAD, Notebook PC
Wireless charging PAD	WCD-H100	LGIT	-	Notebook PC
Notebook PC	ProBook6560b	HP	DoC	Gateway , Wireless charging PAD, Notebook PC adaptor, RJ45 cable, Serial mouse
Notebook PC adaptor	Series PPP009L-E	LITE-ON Technology	-	Notebook PC
Gateway	TL-WR747N	TP-LINK	-	RJ45 cable, Gateway adaptor
Gateway adaptor	T120150-2H1	TP-LINK	-	Gateway
Serial mouse	Serial 2 button mouse	Radio shack	FSUGMZE3	Notebook PC
RJ45 cable	-	-	-	Notebook PC, Gateway



1.6 Cable Description

Product Name	Port	Power Cord Shielded (Y/N)	I/O Cable Shielded (Y/N)	Length (m)
EUT	-	-	-	-
Wireless charging PAD	USB type C	Y	Y	(P)1.0
Notebook PC	RJ 45	N/A	N	(D)2.5
	Serial (Mouse)	N/A	Y	(D)1.8
	DC in	N	N/A	(P)1.8
Gateway	DC in	N	N/A	(P)1.8

* The marked “(D)” means the data cable and “(P)” means the power cable.

1.7 Noise Suppression Parts on Cable. (I/O Cable)

Product Name	Port	Ferrite Bead (Y/N)	Location	Metal Hood (Y/N)	Location
EUT	-	-	-	-	Both End
Wireless charging PAD	USB type C	N	N/A	Y	Both End
Notebook PC	RJ 45	N	N/A	N	N/A
	Serial (Mouse)	N	N/A	Y	Notebook PC End



2. MEASUREMENT UNCERTAINTY

The measurement uncertainties shown below were calculated in accordance with the requirements of ANSI C63.4-2014.

All measurement uncertainty values are shown with a coverage factor of $k = 2$ to indicate a 95 % level of confidence. The measurement data shown herein meets or exceeds the U_{CISPR} measurement uncertainty values specified in CISPR 16-4-2 and, thus, can be compared directly to specified limits to determine compliance.

Parameter	Expanded Uncertainty (dB)
Conducted Emission	$\pm 1.82 \text{ dB } (k = 2)$
Radiated Emissions (30 MHz to 1 GHz)	$\pm 5.06 \text{ dB } (k = 2)$
Radiated Emissions (1 GHz to 6 GHz)	$\pm 5.0 \text{ dB } (k = 2)$
Radiated Emissions (6 GHz to 18 GHz)	$\pm 5.4 \text{ dB } (k = 2)$



3. DESCRIPTION OF TEST

3.1 Measurement of Conducted Emission

The test procedure was in accordance with ANSI C63.4-2014, Clause 7.3

- a. The EUT was placed 0.4 meters from the conducting wall of the shielded room with EUT being connected to the power mains through a line impedance stabilization network (LISN).
If the EUT is connected to the PC through USB, the AC power-line adapter of the PC is directly connected to a line impedance stabilization network (LISN).
Other support units were connected to the power mains through another LISN. The two LISNs provide 50 Ohm/ 50uH of coupling impedance for the measuring instrument.
- b. Both conducted lines are measured in Quasi-Peak and Average mode, including the worst-case data points for each tested configuration.
- c. The frequency range from 150 kHz to 30 MHz was searched.

[Conducted Emission Limits]

Frequency (MHz)	Resolution Bandwidth (kHz)	Quasi-Peak (dB(μV))	Average (dB(μV))
0.15 to 0.5	9	66 to 56*	56 to 46*
0.5 to 5	9	56	46
5 to 30	9	60	50

**Decreases with the logarithm of the frequency.*



3.2 Measurement of Radiated Emission

The test procedure was in accordance with ANSI C63.4-2014, Clause 8.3

- a. The EUT was placed on the top of a turn table 0.8 meters above the ground at a semi-anechoic chamber. The table was rotated 360 degrees to determine the position of the highest radiation.
- b. The EUT was set 3 m away from the interference-receiving antenna, which was mounted on the top of a variable-height antenna tower.
- c. The antenna height is varied from 1 m to 4 m above the ground to determine the maximum value of the field strength. Both horizontal and vertical polarizations of the antenna are set to make the measurement.
- d. For each suspected emission, the EUT was arranged to its worst case and then the antenna was tuned to heights from 1 m to 4 m and the turn table was turned from 0 degrees to 360 degrees to find the maximum reading.
- e. The test-receiver system was set to Quasi-Peak detect function and specified bandwidth with maximum hold mode when the test frequency is below 1 GHz.
- f. The test-receiver system was set to Peak and Average detect function and specified bandwidth with maximum hold mode when the test frequency is above 1 GHz.
- g. Place the measurement antenna away from each area of the EUT determined to be a source of emissions at the specified measurement distance, while keeping the measurement antenna aimed at the source of emissions at each frequency of significant emissions, with polarization oriented for maximum response.(1 GHz to 40 GHz)

[Radiated Emission Limits]

Frequency (MHz)	Antenna Distance (m)	Field Strength ($\mu\text{V}/\text{m}$)	Quasi-Peak ($\text{dB}(\mu\text{V})/\text{m}$)
30 to 88	3	100	40.0
88 to 216	3	150	43.5
216 to 960	3	200	46.0
Above 960	3	500	54.0
Frequency (MHz)	Antenna Distance (m)	Peak ($\text{dB}(\mu\text{V})/\text{m}$)	Average ($\text{dB}(\mu\text{V})/\text{m}$)
Above 1 000	3	74	54



3.2.1 Frequency Range of Radiated Measurements

An unintentional radiator, including a digital device, the spectrum shall be investigated from the lowest radio frequency signal generated or used in the device, without going below the lowest frequency for which a Radiated Emission limit is specified, up to the frequency shown in the following table

Highest frequency generated or used in the device or on which the device operates or tunes (MHz)	Upper frequency of measurement range (MHz)
Below 1.705	30
1.705 to 108	1 000
108 to 500	2 000
500 to 1 000	5 000
Above 1 000	5 th harmonic of the highest frequency or 40 GHz, whichever is lower

3.3 Configuration of Tested System

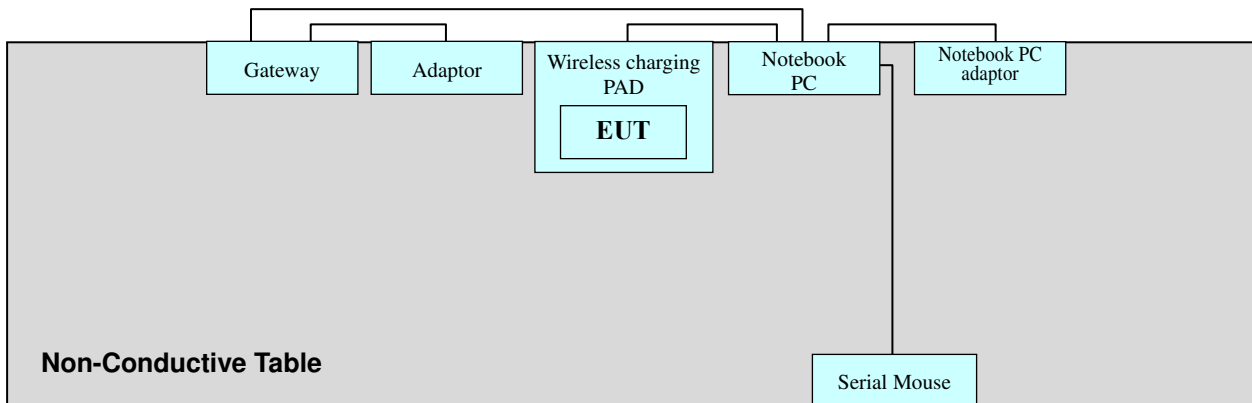

Power Line: 120 VAC, 60 Hz



4. PRELIMINARY TEST

4.1 Conducted Emission Test

It was tested Charging mode, after connecting all peripheral devices.

Operation Mode: Charging mode

4.2 Radiated Emission Test

It was tested Charging mode, after connecting all peripheral devices.

Operation Mode: Charging mode



5. CONDUCTED AND RADIATED EMISSION TEST SUMMARY

5.1 Conducted Emission Test

The test results of conducted emission at mains ports provide the following information:

Rule Part / Standard	FCC PART 15 Subpart B Class B
Detector	Quasi-Peak, CISPR-Average
Bandwidth	9 kHz (6 dB)
Operation Mode	Charging mode
Kind of Test Site	Shielded Room
Temperature	22.4 °C
Relative Humidity	29.9 %
Test Date	November 10, 2016

- Calculation Formula:

1. Conductor L1 = Hot, Conductor N = Neutral
2. Corr. = LISN Factor + Cable Loss
3. QuasiPeak or CAverage= Receiver Reading + Corr.
4. Margin = Limit – QuasiPeak or CAverage



Figure 1: Spectral Diagrams, Conducted Emission, AC Main Port, Line (L1)

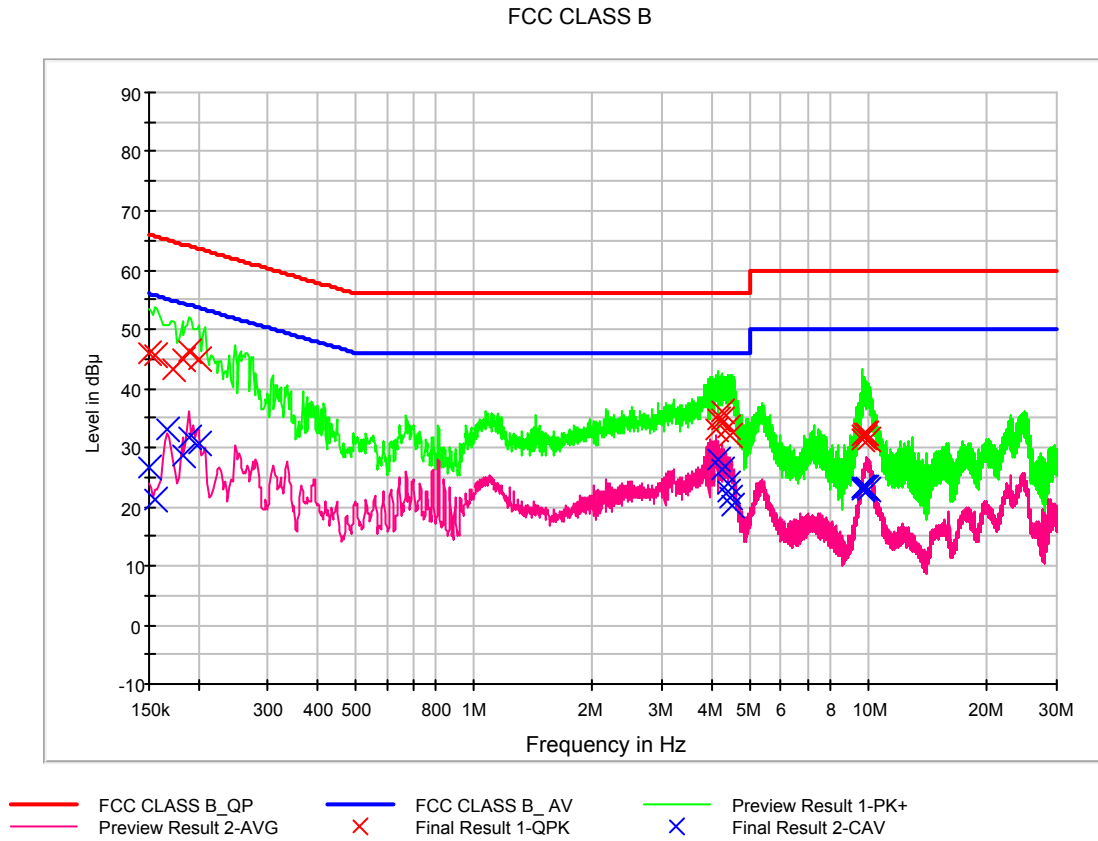



QuasiPeak Final Result, Line (L1)

Frequency (MHz)	QuasiPeak (dBuV)	Bandwidth (kHz)	Line	Corr. (dB)	Margin (dB)	Limit (dBuV)
0.150000	45.9	9.000	L1	9.7	20.1	66.0
0.156000	45.6	9.000	L1	9.7	20.1	65.7
0.172000	43.1	9.000	L1	9.7	21.8	64.9
0.182000	44.8	9.000	L1	9.7	19.6	64.4
0.190000	46.2	9.000	L1	9.7	17.9	64.0
0.200000	44.9	9.000	L1	9.7	18.7	63.6
4.128000	33.1	9.000	L1	9.9	22.9	56.0
4.158000	34.6	9.000	L1	9.9	21.4	56.0
4.230000	35.9	9.000	L1	9.9	20.1	56.0
4.242000	34.8	9.000	L1	9.9	21.2	56.0
4.420000	33.4	9.000	L1	9.9	22.6	56.0
4.458000	32.1	9.000	L1	9.9	23.9	56.0
9.618000	31.5	9.000	L1	10.1	28.5	60.0
9.670000	32.2	9.000	L1	10.1	27.8	60.0
9.704000	32.4	9.000	L1	10.1	27.6	60.0
9.814000	31.8	9.000	L1	10.1	28.2	60.0
9.840000	32.2	9.000	L1	10.1	27.8	60.0
9.950000	31.3	9.000	L1	10.1	28.7	60.0



CAverage Final Result, Line (L1)

Frequency (MHz)	CAverage (dBuV)	Bandwidth (kHz)	Line	Corr. (dB)	Margin (dB)	Limit (dBuV)
0.150000	26.5	9.000	L1	9.7	29.5	56.0
0.156000	21.2	9.000	L1	9.7	34.5	55.7
0.166000	32.9	9.000	L1	9.7	22.3	55.2
0.182000	28.8	9.000	L1	9.7	25.6	54.4
0.190000	31.8	9.000	L1	9.7	22.2	54.0
0.200000	30.8	9.000	L1	9.7	22.8	53.6
4.160000	28.0	9.000	L1	9.9	18.0	46.0
4.240000	26.3	9.000	L1	9.9	19.7	46.0
4.382000	22.6	9.000	L1	9.9	23.4	46.0
4.420000	24.0	9.000	L1	9.9	22.0	46.0
4.458000	21.6	9.000	L1	9.9	24.4	46.0
4.516000	20.2	9.000	L1	9.9	25.8	46.0
9.618000	22.9	9.000	L1	10.1	27.1	50.0
9.670000	23.1	9.000	L1	10.1	26.9	50.0
9.698000	23.1	9.000	L1	10.1	26.9	50.0
9.714000	23.3	9.000	L1	10.1	26.7	50.0
9.884000	23.3	9.000	L1	10.1	26.7	50.0
9.950000	22.8	9.000	L1	10.1	27.2	50.0



Figure 2: Spectral Diagrams, Conducted Emission, AC Main Port, Line (N)

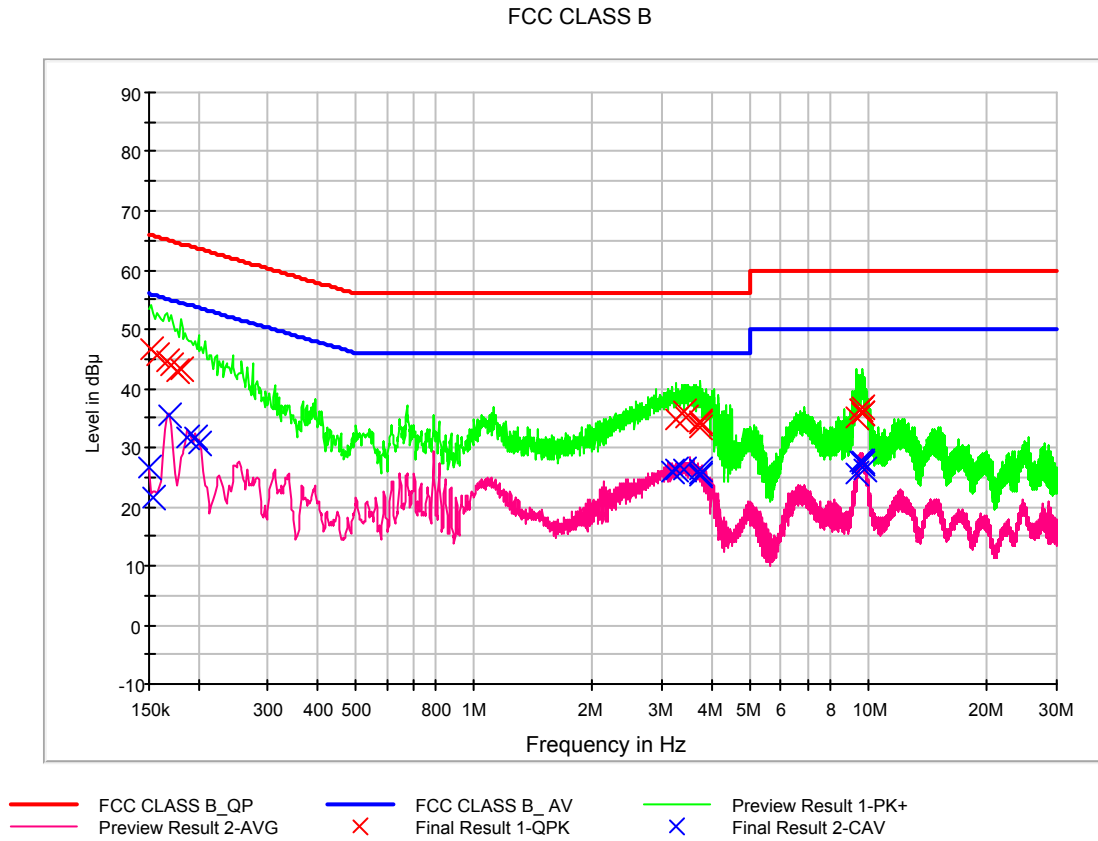



QuasiPeak Final Result, Line (N)

Frequency (MHz)	QuasiPeak (dBuV)	Bandwidth (kHz)	Line	Corr. (dB)	Margin (dB)	Limit (dBuV)
0.152000	46.5	9.000	N	9.7	19.4	65.9
0.158000	45.4	9.000	N	9.7	20.1	65.6
0.166000	44.7	9.000	N	9.7	20.5	65.2
0.170000	44.0	9.000	N	9.7	21.0	65.0
0.176000	43.0	9.000	N	9.7	21.7	64.7
0.180000	43.2	9.000	N	9.7	21.3	64.5
3.250000	34.7	9.000	N	9.8	21.4	56.0
3.410000	36.2	9.000	N	9.8	19.8	56.0
3.454000	35.0	9.000	N	9.8	21.0	56.0
3.726000	34.2	9.000	N	9.8	21.8	56.0
3.748000	34.3	9.000	N	9.8	21.7	56.0
3.758000	33.4	9.000	N	9.8	22.6	56.0
9.346000	34.9	9.000	N	10.0	25.1	60.0
9.526000	36.3	9.000	N	10.0	23.7	60.0
9.558000	36.5	9.000	N	10.0	23.5	60.0
9.610000	36.6	9.000	N	10.0	23.4	60.0
9.686000	35.7	9.000	N	10.0	24.3	60.0
9.696000	35.8	9.000	N	10.0	24.2	60.0



CAverage Final Result, Line (N)

Frequency (MHz)	CAverage (dBuV)	Bandwidth (kHz)	Line	Corr. (dB)	Margin (dB)	Limit (dBuV)
0.150000	26.8	9.000	N	9.7	29.2	56.0
0.154000	21.5	9.000	N	9.7	34.3	55.8
0.168000	35.6	9.000	N	9.7	19.5	55.1
0.188000	31.8	9.000	N	9.7	22.3	54.1
0.196000	31.6	9.000	N	9.7	22.2	53.8
0.200000	30.8	9.000	N	9.7	22.8	53.6
3.182000	26.1	9.000	N	9.8	19.9	46.0
3.250000	26.2	9.000	N	9.8	19.8	46.0
3.390000	26.2	9.000	N	9.8	19.8	46.0
3.726000	25.7	9.000	N	9.8	20.3	46.0
3.748000	26.3	9.000	N	9.8	19.7	46.0
3.758000	25.3	9.000	N	9.8	20.7	46.0
9.346000	25.7	9.000	N	10.0	24.3	50.0
9.532000	27.7	9.000	N	10.0	22.3	50.0
9.626000	27.7	9.000	N	10.0	22.3	50.0
9.686000	27.3	9.000	N	10.0	22.7	50.0
9.696000	27.3	9.000	N	10.0	22.7	50.0
9.768000	26.2	9.000	N	10.0	23.8	50.0



5.2 Radiated Emission Test

The test results of radiated emission provide the following information:

-For Measurement Below 1 GHz

Rule Part / Standard	FCC PART 15 Subpart B Class B
Detector	Quasi-Peak
Bandwidth	120 kHz (6 dB)
Operation Mode	Charging mode
Kind of Test Site	3 m semi anechoic chamber
Temperature	21.6 °C
Relative Humidity	32.0 %
Test Date	November 09, 2016

Frequency (MHz)	Quasi Peak (dB μ V/m)	Antenna Height (cm)	POL. (H/V)	Azimuth (deg)	Corr. (dB)	Margin (dB)	Limit (dB μ V/m)
45.915200	25.1	134.0	V	42.0	22.7	14.9	40.0
58.788800	31.4	100.0	V	345.0	22.5	8.6	40.0
63.512000	33.8	100.0	V	125.0	22.0	6.2	40.0
122.676000	23.6	100.0	V	193.0	20.8	19.9	43.5
174.742400	24.4	100.0	V	155.0	21.9	19.1	43.5
265.616800	32.6	116.0	H	71.0	22.6	13.4	46.0

- Calculation Formula:

1. POL. H = Horizontal, POL. V = Vertical
2. QuasiPeak = Reading (Receiver Reading) + Corr.
3. Corr. (Correction Factor) = Antenna Factor + Cable Loss
4. Margin = Limit - QuasiPeak



-For Measurement Above 1 GHz

Rule Part / Standard	FCC PART 15 Subpart B Class B
Detector	Peak mode: Peak (RBW: 1 MHz, VBW: 3 MHz) CISPR-Average mode: Peak (RBW: 1 MHz, VBW: 10 Hz)
Highest Operating Frequency	2 480 MHz
Upper Frequency of Measurement Range	1 GHz to 12.4 GHz
Operation Mode	Charging mode
Kind of Test Site	3 m semi anechoic chamber
Temperature	21.6 °C
Relative Humidity	32.0 %
Test Date	November 09, 2016

Frequency (MHz)	Peak (dB μ V/m)	Antenna Height (cm)	POL. (H/V)	Azimuth (deg)	Corr. (dB)	Margin (dB)	Limit (dB μ V/m)
1330.560000	41.7	362.9	V	207.0	-13.0	32.3	74.0
1399.995000	47.5	352.5	V	40.0	-12.8	26.5	74.0
1991.580000	48.9	111.6	V	215.0	-12.2	25.1	74.0
2075.900000	47.3	99.9	V	228.0	-11.8	26.7	74.0
2588.985000	48.7	358.7	V	208.0	-9.3	25.3	74.0
2663.925000	46.3	126.6	V	174.0	-9.1	27.7	74.0

Frequency (MHz)	CAverage (dB μ V/m)	Antenna Height (cm)	POL. (H/V)	Azimuth (deg)	Corr. (dB)	Margin (dB)	Limit (dB μ V/m)
1330.560000	22.7	362.9	V	207.0	-13.0	31.3	54.0
1399.995000	46.1	352.5	V	40.0	-12.8	7.9	54.0
1991.580000	30.4	111.6	V	215.0	-12.2	23.6	54.0
2075.900000	30.7	99.9	V	228.0	-11.8	23.3	54.0
2588.985000	29.0	358.7	V	208.0	-9.3	25.0	54.0
2663.925000	27.1	126.6	V	174.0	-9.1	26.9	54.0

- Calculation Formula:

1. POL. H = Horizontal, POL. V = Vertical
2. Peak or CAverage = Reading (Receiver Reading) + Corr.
3. Corr. (Correction Factor) = Antenna Factor+ Cable Loss –Amplifier Gain
4. Margin = Limit - Peak or CAverage



6. LIST OF TEST EQUIPMENT

<u>Type</u>	<u>Manufacturer</u>	<u>Model Name</u>	<u>Serial Number</u>	<u>Calibration Cycle</u>	<u>CAL Date</u>
<u>Conducted Emission</u>					
<input checked="" type="checkbox"/> EMI Test Receiver	Rohde & Schwarz	ESCI	100584	1 year	12.28.2015
<input checked="" type="checkbox"/> LISN	Rohde & Schwarz	ESH3-Z5	100282	1 year	06.09.2016
<input checked="" type="checkbox"/> LISN	Rohde & Schwarz	ENV216	100073	1 year	12.28.2015
<input type="checkbox"/> Software	Rohde & Schwarz	EMC32	-	-	-
<u>Radiated Emission</u>					
-For measurement below 1 GHz					
<input type="checkbox"/> EMI Test Receiver	Rohde & Schwarz	ESI40	831564103	1 year	03.30.2016
<input type="checkbox"/> EMI Test Receiver	Rohde & Schwarz	ESIB26	100298	1 year	02.11.2016
<input checked="" type="checkbox"/> EMI Test Receiver	Rohde & Schwarz	ESU40	100514	1 year	10.10.2016
<input checked="" type="checkbox"/> Trilog Antenna	Schwarzbeck	VULB9168	255	2 year	04.15.2015
<input checked="" type="checkbox"/> 6dB Attenuator	HP	8491A	24257	2 year	04.15.2015
<input checked="" type="checkbox"/> Antenna master	HD GmbH	MA240	240/520	N/A	-
<input checked="" type="checkbox"/> Antenna master controller	HD GmbH	HD 100	100/637	N/A	-
<input checked="" type="checkbox"/> Turn Table	EMCO	1060-2M	-	N/A	-
<input checked="" type="checkbox"/> Turn Table controller	EMCO	2090	9702-1224	N/A	-
<input type="checkbox"/> EMI Test Receiver	Rohde & Schwarz	ESU 26	100241	1 year	05.27.2016
<input type="checkbox"/> Antenna master	INNCO Systems	MA4000-EP	MA4000/283	N/A	-
<input type="checkbox"/> Turn Table	INNCO Systems	DT3000-3T	DT3000/69	N/A	-
<input checked="" type="checkbox"/> Software	Rohde & Schwarz	EMC32	-	-	-
-For measurement above 1 GHz					
<input type="checkbox"/> EMI Test Receiver	Rohde & Schwarz	ESI40	831564103	1 year	03.30.2016
<input type="checkbox"/> EMI Test Receiver	Rohde & Schwarz	ESIB26	100298	1 year	02.11.2016
<input checked="" type="checkbox"/> EMI Test Receiver	Rohde & Schwarz	ESU40	100514	1 year	10.10.2016
<input type="checkbox"/> Antenna master	HD GmbH	MA240	240/520	N/A	-
<input type="checkbox"/> Antenna master controller	HD GmbH	HD 100	100/637	N/A	-
<input checked="" type="checkbox"/> Antenna master	INNCO Systems	MA4000-XP-ET	48709515	N/A	-
<input checked="" type="checkbox"/> Antenna master controller	INNCO Systems	CO 3000	CO 3000/870/ 35990515	N/A	-
<input checked="" type="checkbox"/> Turn Table	EMCO	1060-2M	-	N/A	-
<input checked="" type="checkbox"/> Turn Table controller	EMCO	2090	9702-1224	N/A	-
<input type="checkbox"/> Power Amplifier	CERNEX	CBLU1183540	21691	1 year	07.04.2016
<input checked="" type="checkbox"/> Power Amplifier	CERNEX	CBLU5183530	24348	1 year	06.07.2016
<input checked="" type="checkbox"/> Horn Antenna	Schwarzbeck	BBHA 9120D	296	2 year	10.12.2016
<input type="checkbox"/> Horn Antenna	Schwarzbeck	BBHA 9170	BBHA9170541	2 year	09.03.2015
<input type="checkbox"/> Power Amplifier	CERNEX	CBL18265035	22966	1 year	07.11.2016
<input type="checkbox"/> Power Amplifier	CERNEX	CBL26405040	19660	1 year	07.15.2016
<input type="checkbox"/> Horn Antenna	Schwarzbeck	BBHA 9120D	1300	2 year	08.25.2016
<input type="checkbox"/> EMI Test Receiver	Rohde & Schwarz	ESU 26	100241	1 year	05.27.2016
<input type="checkbox"/> Turn Table	INNCO Systems	DT3000-3T	DT3000/69	N/A	-
<input checked="" type="checkbox"/> Software	Rohde & Schwarz	EMC32	-	-	-



7. CONCLUSION

The data collected shows that the **EUT Type: Portable Wrist Device, Model: LG-W280, FCC ID: ZNFW280** complies with §15.107 and §15.109 of the FCC rules.