

20120529_SystemPerformanceCheck-D1900V2 SN 5d043

Frequency: 1900 MHz; Duty Cycle: 1:1; Room Ambient Temperature: 24.0°C; Liquid Temperature: 23.0°C
Medium parameters used: $f = 1900$ MHz; $\sigma = 1.535$ mho/m; $\epsilon_r = 51.46$; $\rho = 1000$ kg/m³

DASY5 Configuration:

- Electronics: DAE3 Sn500; Calibrated: 7/14/2011
- Probe: EX3DV4 - SN3773; ConvF(7.11, 7.11, 7.11); Calibrated: 3/14/2012
- Sensor-Surface: 2.5mm (Mechanical Surface Detection)
- Phantom: ELI v5.0 (A); Type: QDOVA001BB; Serial: 1120

Body/Pin=100 mW/Area Scan (7x7x1): Measurement grid: dx=15mm, dy=15mm

Maximum value of SAR (measured) = 4.764 mW/g

Body/Pin=100 mW/Zoom Scan (7x7x7)/Cube 0: Measurement grid: dx=5mm, dy=5mm, dz=5mm

Reference Value = 60.640 V/m; Power Drift = 0.01 dB

Peak SAR (extrapolated) = 7.5900

SAR(1 g) = 4.16 mW/g; SAR(10 g) = 2.17 mW/g

Maximum value of SAR (measured) = 5.596 mW/g

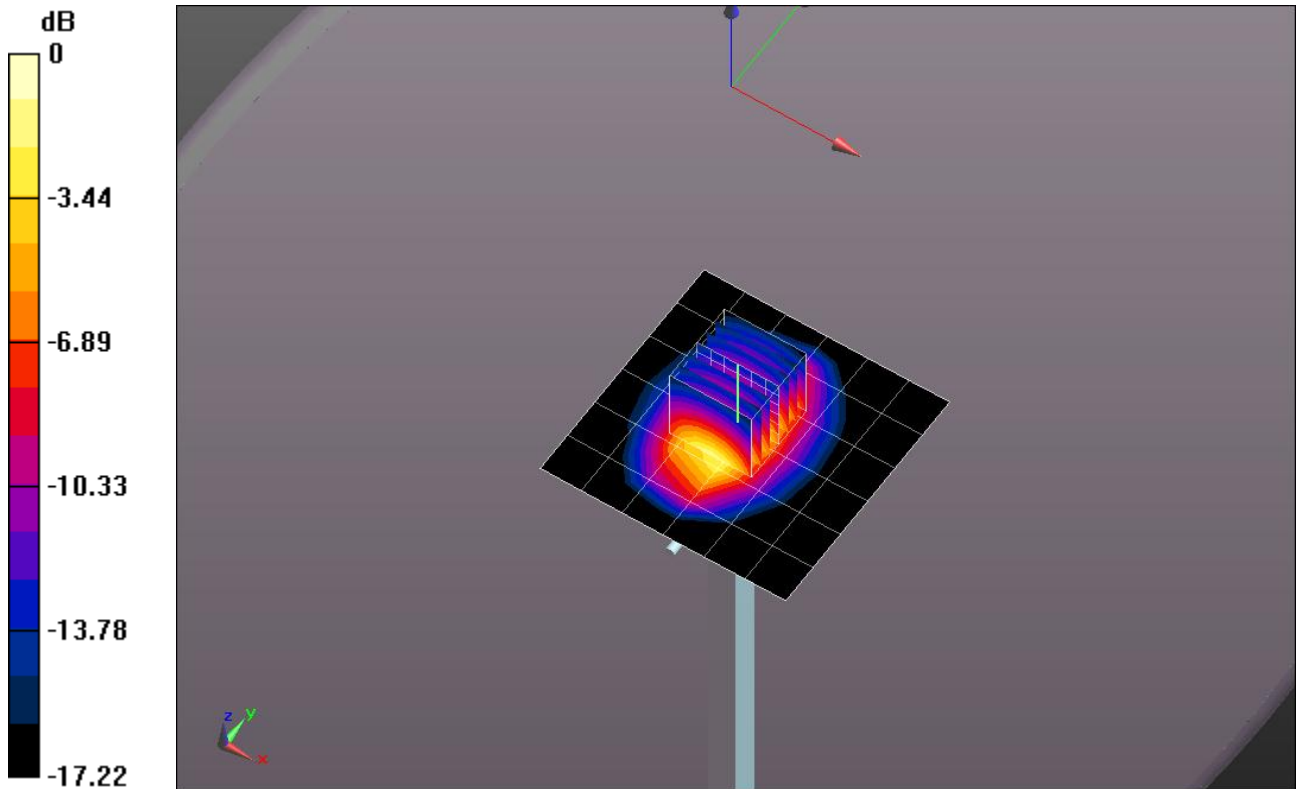

0 dB = 5.600mW/g = 14.96 dB mW/g

20120529_SystemPerformanceCheck-D1900V2 SN 5d043

Frequency: 1900 MHz; Duty Cycle: 1:1

Body/Pin=100 mW/Z Scan (1x1x21): Measurement grid: dx=20mm, dy=20mm, dz=5mm
Maximum value of SAR (measured) = 4.001 mW/g

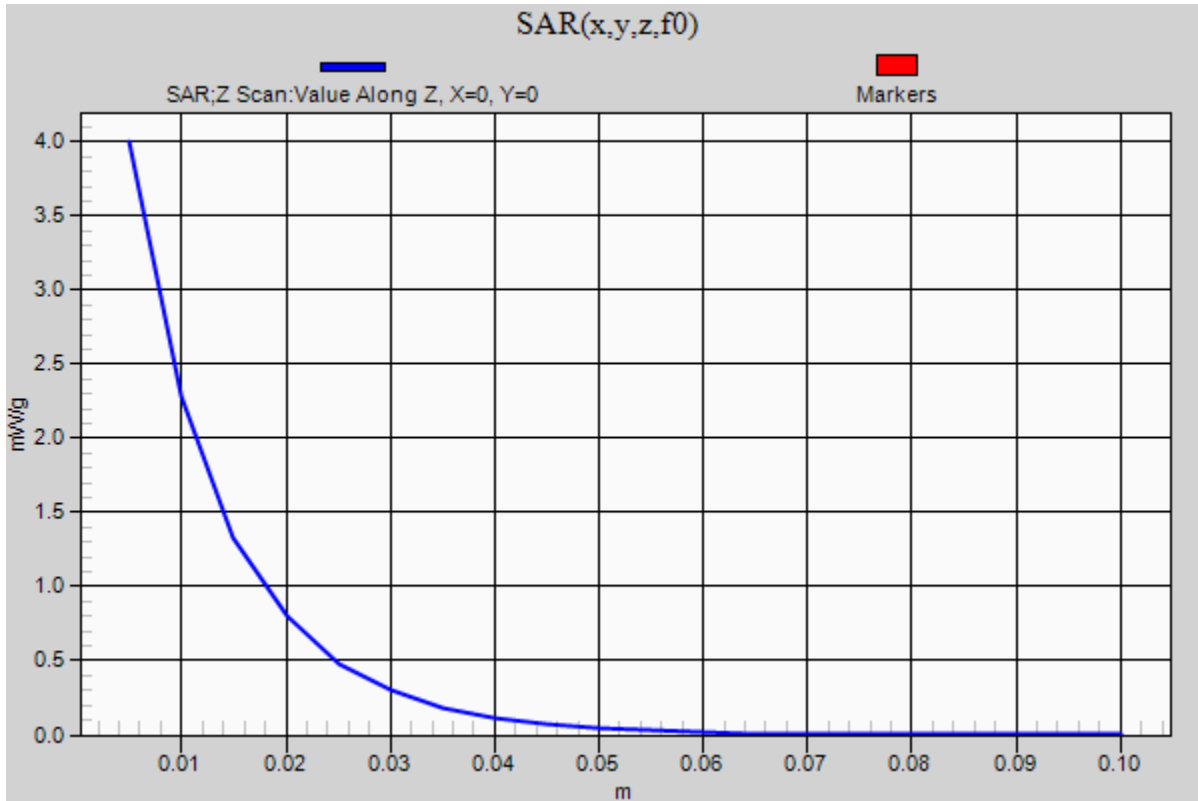

20120530_SystemPerformanceCheck-D835V2 SN 4d002

Frequency: 835 MHz; Duty Cycle: 1:1; Room Ambient Temperature: 24.0°C; Liquid Temperature: 23.0°C

Medium parameters used: $f = 835 \text{ MHz}$; $\sigma = 0.991 \text{ mho/m}$; $\epsilon_r = 54.567$; $\rho = 1000 \text{ kg/m}^3$

DASY5 Configuration:

- Electronics: DAE3 Sn500; Calibrated: 7/14/2011
- Probe: EX3DV4 - SN3773; ConvF(8.74, 8.74, 8.74); Calibrated: 3/14/2012
- Sensor-Surface: 2.5mm (Mechanical Surface Detection)
- Phantom: ELI v5.0 (B); Type: QDOVA001BB; Serial: 1118

Body/Pin=100 mW/Area Scan (7x7x1): Measurement grid: dx=15mm, dy=15mm

Maximum value of SAR (measured) = 1.106 mW/g

Body/Pin=100 mW/Zoom Scan (7x7x7)/Cube 0: Measurement grid: dx=5mm, dy=5mm, dz=5mm

Reference Value = 35.515 V/m; Power Drift = 0.03 dB

Peak SAR (extrapolated) = 1.5010

SAR(1 g) = 1.02 mW/g; SAR(10 g) = 0.669 mW/g

Maximum value of SAR (measured) = 1.235 mW/g

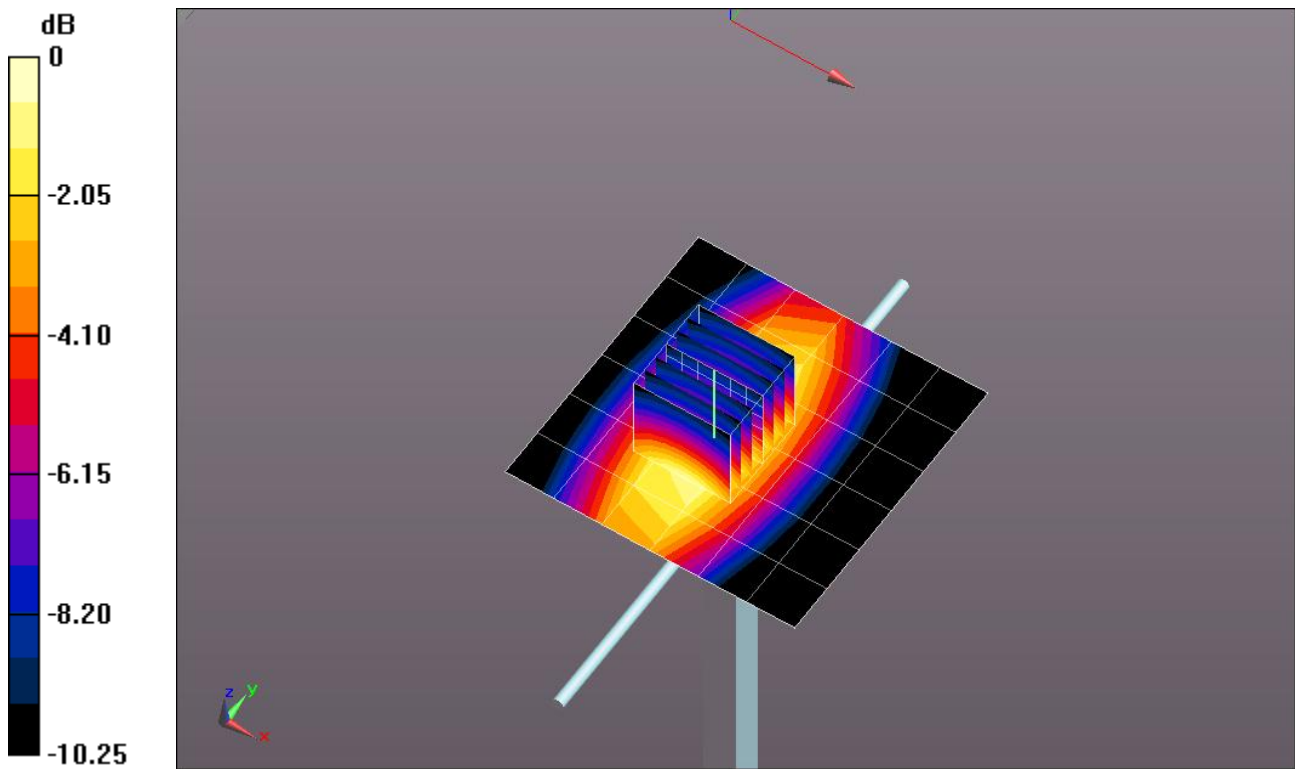

0 dB = 1.240mW/g = 1.87 dB mW/g

20120530_SystemPerformanceCheck-D835V2 SN 4d002

Frequency: 835 MHz; Duty Cycle: 1:1

Body/Pin=100 mW/Z Scan (1x1x21): Measurement grid: dx=20mm, dy=20mm, dz=5mm
Maximum value of SAR (measured) = 0.820 mW/g

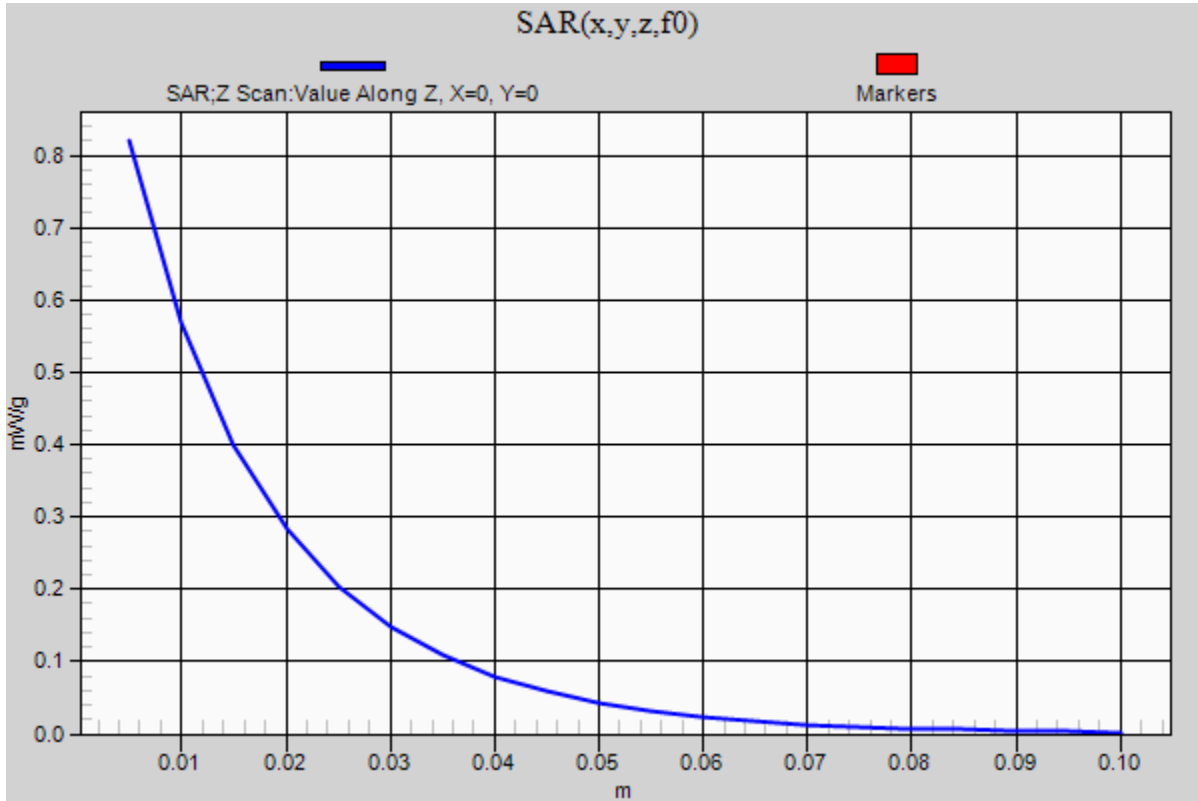

20120531_SystemPerformanceCheck-D835V2 SN 4d002

Frequency: 835 MHz; Duty Cycle: 1:1; Room Ambient Temperature: 24.0°C; Liquid Temperature: 23.0°C
 Medium parameters used: $f = 835 \text{ MHz}$; $\sigma = 0.891 \text{ mho/m}$; $\epsilon_r = 42.264$; $\rho = 1000 \text{ kg/m}^3$

DASY5 Configuration:

- Electronics: DAE3 Sn500; Calibrated: 7/14/2011
- Probe: EX3DV4 - SN3773; ConvF(8.79, 8.79, 8.79); Calibrated: 3/14/2012
- Sensor-Surface: 2.5mm (Mechanical Surface Detection)
- Phantom: SAM; Type: QD000P40CD; Serial: 1632

Head/Pin=100 mW/Area Scan (7x7x1): Measurement grid: dx=15mm, dy=15mm

Maximum value of SAR (measured) = 0.983 mW/g

Head/Pin=100 mW/Zoom Scan (7x7x7)/Cube 0: Measurement grid: dx=5mm, dy=5mm, dz=5mm

Reference Value = 35.934 V/m; Power Drift = -0.0029 dB

Peak SAR (extrapolated) = 1.4100

SAR(1 g) = 0.934 mW/g; SAR(10 g) = 0.611 mW/g

Maximum value of SAR (measured) = 1.138 mW/g

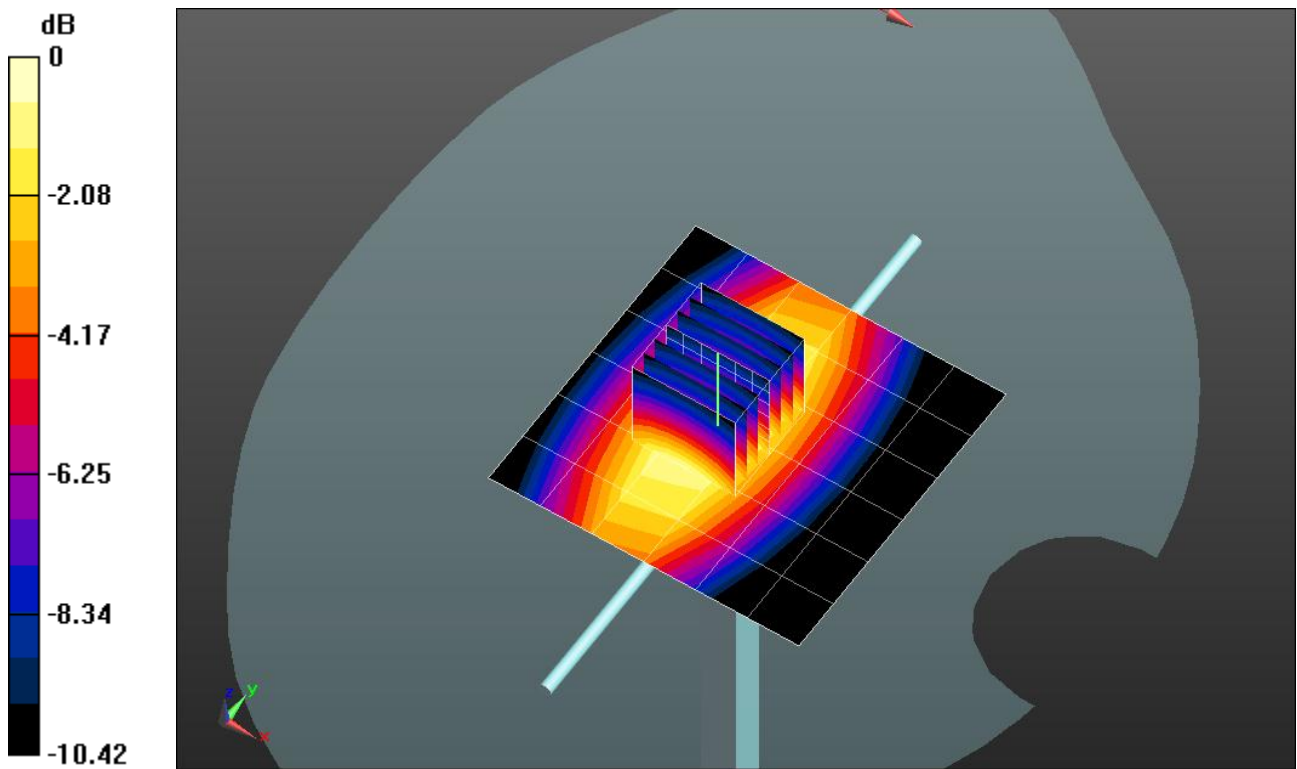

0 dB = 1.140mW/g = 1.14 dB mW/g

20120531_SystemPerformanceCheck-D835V2 SN 4d002

Frequency: 835 MHz; Duty Cycle: 1:1

Head/Pin=100 mW/Z Scan (1x1x21): Measurement grid: dx=20mm, dy=20mm, dz=5mm
Maximum value of SAR (measured) = 0.791 mW/g

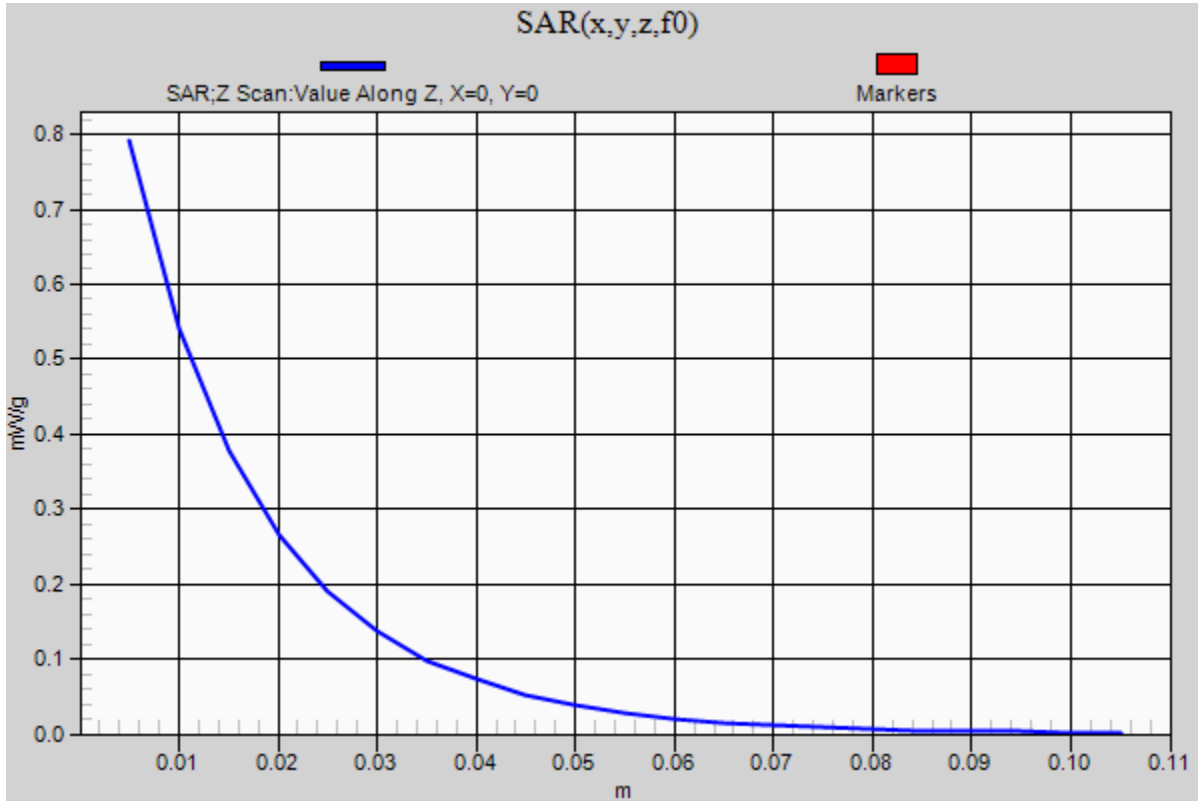

20120531_SystemPerformanceCheck-D1900V2 SN 5d043

Frequency: 1900 MHz; Duty Cycle: 1:1; Room Ambient Temperature: 24.0°C; Liquid Temperature: 23.0°C

Medium parameters used: $f = 1900$ MHz; $\sigma = 1.41$ mho/m; $\epsilon_r = 38.541$; $\rho = 1000$ kg/m³

DASY5 Configuration:

- Electronics: DAE4 Sn1257; Calibrated: 10/25/2011
- Probe: EX3DV4 - SN3773; ConvF(7.51, 7.51, 7.51); Calibrated: 3/14/2012
- Sensor-Surface: 2.5mm (Mechanical Surface Detection)
- Phantom: SAM; Type: QD000P40CD; Serial: 1632

Head/Pin=100 mW/Area Scan (7x7x1): Measurement grid: dx=15mm, dy=15mm

Maximum value of SAR (measured) = 3.931 mW/g

Head/Pin=100 mW/Zoom Scan (7x7x7)/Cube 0: Measurement grid: dx=5mm, dy=5mm, dz=5mm

Reference Value = 60.581 V/m; Power Drift = 0.02 dB

Peak SAR (extrapolated) = 7.3330

SAR(1 g) = 4.01 mW/g; SAR(10 g) = 2.09 mW/g

Maximum value of SAR (measured) = 5.389 mW/g

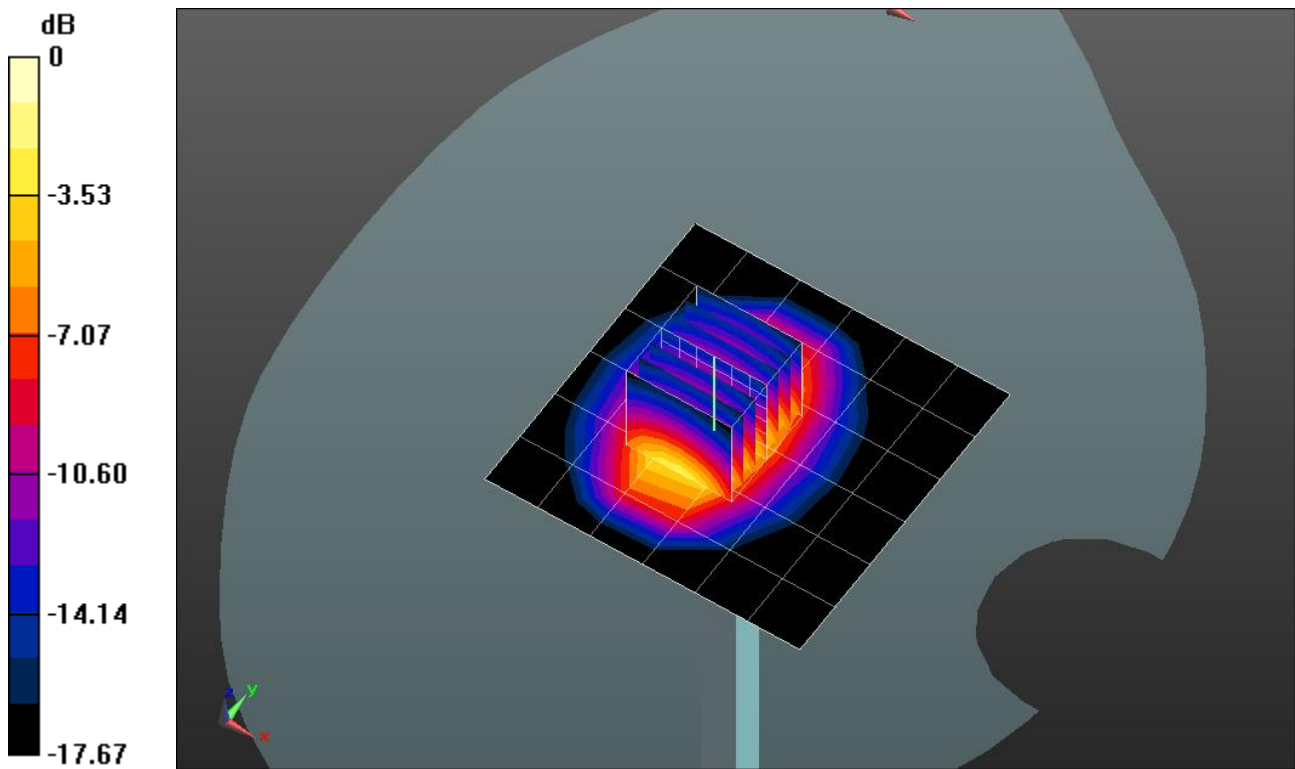

0 dB = 5.390mW/g = 14.63 dB mW/g

20120531_SystemPerformanceCheck-D1900V2 SN 5d043

Frequency: 1900 MHz; Duty Cycle: 1:1

Head/Pin=100 mW/Z Scan (1x1x21): Measurement grid: dx=20mm, dy=20mm, dz=5mm
Maximum value of SAR (measured) = 3.070 mW/g

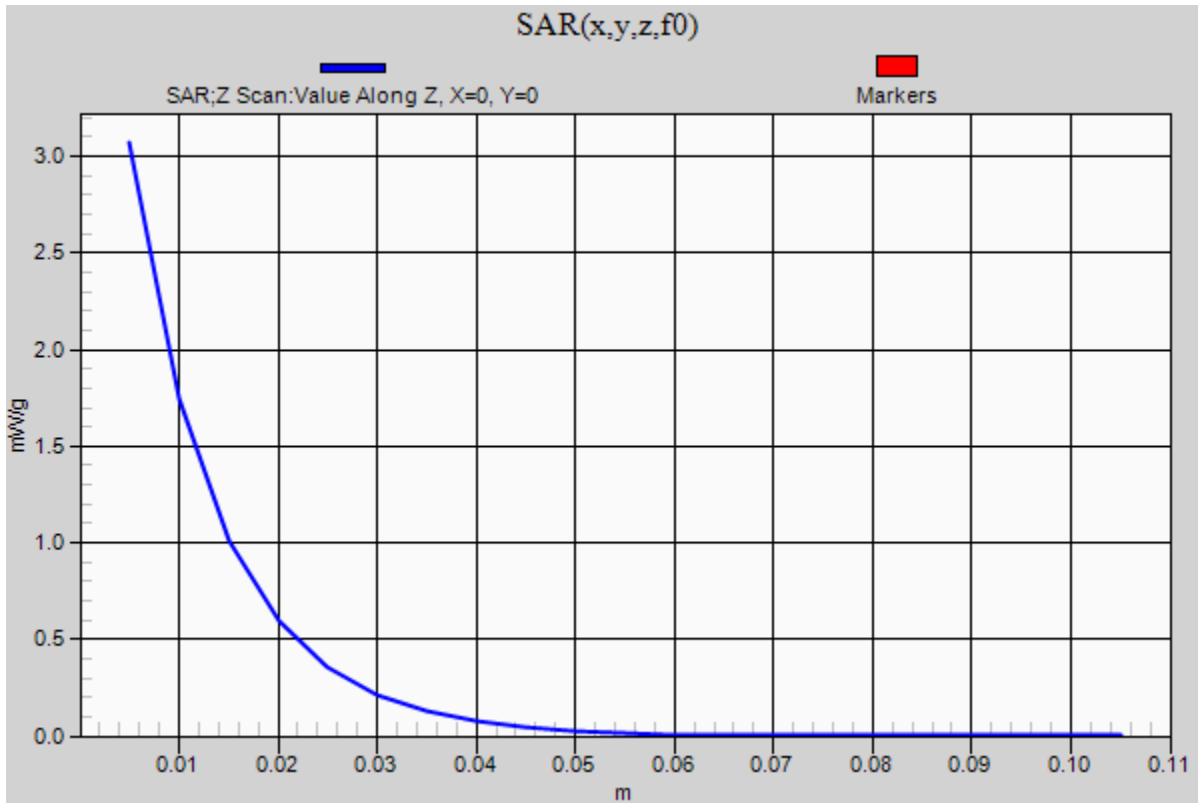

20120605_SystemPerformanceCheck-D1900V2 SN 5d043

Frequency: 1800 MHz; Duty Cycle: 1:1; Room Ambient Temperature: 24.0°C; Liquid Temperature: 23.0°C

Medium parameters used: $f = 1800$ MHz; $\sigma = 1.44$ mho/m; $\epsilon_r = 51.583$; $\rho = 1000$ kg/m³

DASY5 Configuration:

- Electronics: DAE4 Sn1259; Calibrated: 2/13/2012
- Probe: EX3DV4 - SN3686; ConvF(7.44, 7.44, 7.44); Calibrated: 2/16/2012
- Sensor-Surface: 2.5mm (Mechanical Surface Detection)
- Phantom: ELI v5.0 (A); Type: QDOVA001BB; Serial: 1120

Body/Pin=100 mW/Area Scan (7x7x1): Measurement grid: dx=15mm, dy=15mm

Maximum value of SAR (measured) = 4.201 mW/g

Body/Pin=100 mW/Zoom Scan (7x7x7)/Cube 0: Measurement grid: dx=5mm, dy=5mm, dz=5mm

Reference Value = 60.180 V/m; Power Drift = 0.02 dB

Peak SAR (extrapolated) = 6.9050

SAR(1 g) = 3.86 mW/g; SAR(10 g) = 2.01 mW/g

Maximum value of SAR (measured) = 5.217 mW/g

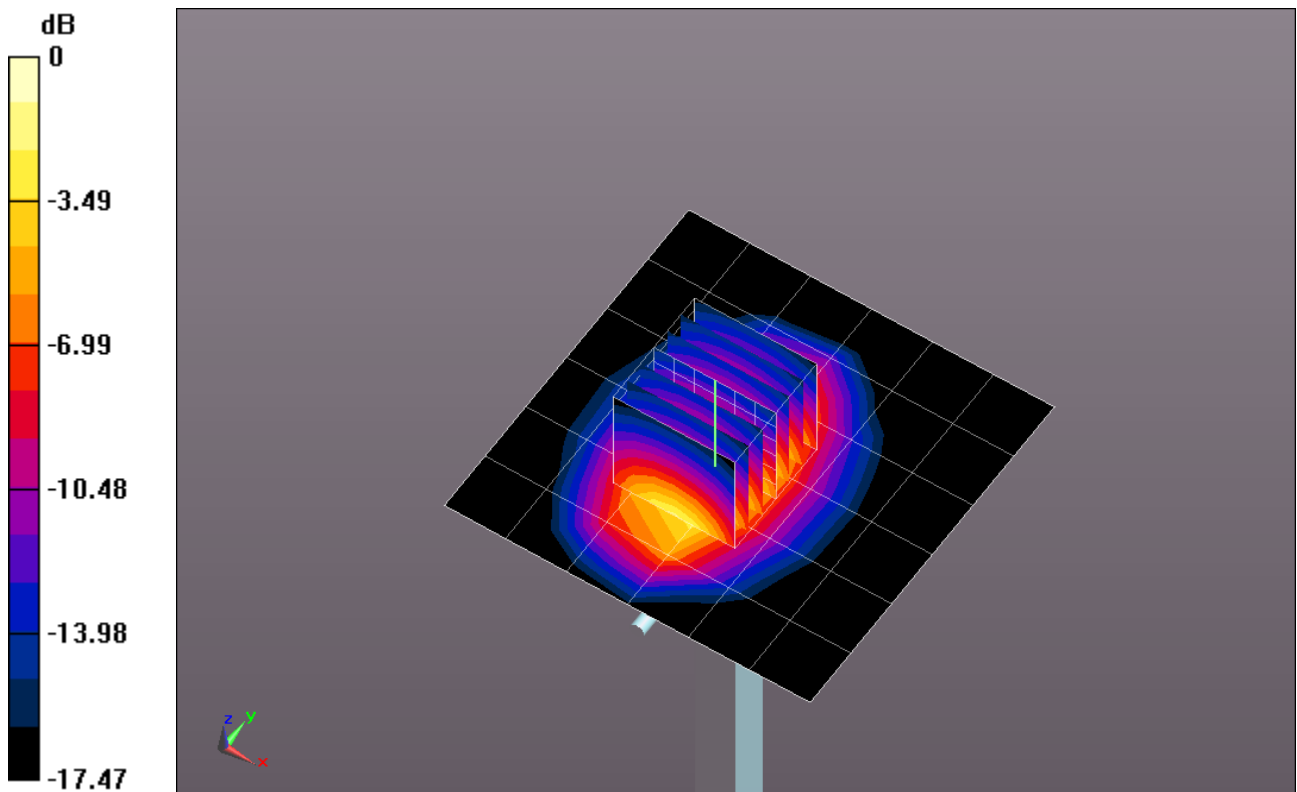

0 dB = 5.220mW/g = 14.35 dB mW/g

20120605_SystemPerformanceCheck-D1900V2 SN 5d043

Frequency: 1800 MHz; Duty Cycle: 1:1

Body/Pin=100 mW/Z Scan (1x1x21): Measurement grid: dx=20mm, dy=20mm, dz=5mm
Maximum value of SAR (measured) = 3.025 mW/g

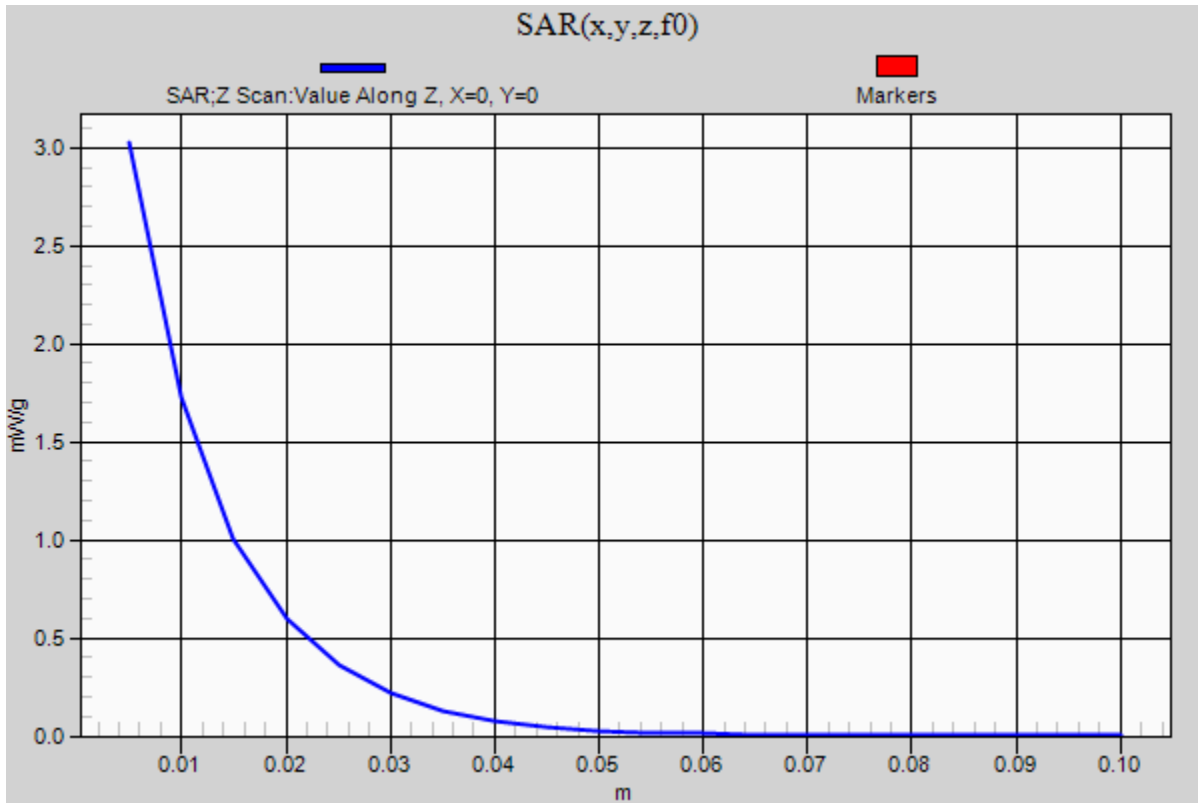

20120605_SystemPerformanceCheck-D1750V2 SN 1050

Frequency: 1750 MHz; Duty Cycle: 1:1; Room Ambient Temperature: 24.0°C; Liquid Temperature: 23.0°C
Medium parameters used: $f = 1750$ MHz; $\sigma = 1.36$ mho/m; $\epsilon_r = 39.851$; $\rho = 1000$ kg/m³

DASY5 Configuration:

- Electronics: DAE4 Sn1259; Calibrated: 2/13/2012
- Probe: EX3DV4 - SN3686; ConvF(7.65, 7.65, 7.65); Calibrated: 2/16/2012
- Sensor-Surface: 2.5mm (Mechanical Surface Detection)
- Phantom: SAM; Type: QD000P40CD; Serial: 1629

Head/Pin=100 mW/Area Scan (7x7x1): Measurement grid: dx=15mm, dy=15mm

Maximum value of SAR (measured) = 4.422 mW/g

Head/Pin=100 mW/Zoom Scan (7x7x7)/Cube 0: Measurement grid: dx=5mm, dy=5mm, dz=5mm

Reference Value = 51.604 V/m; Power Drift = -0.03 dB

Peak SAR (extrapolated) = 6.6100

SAR(1 g) = 3.59 mW/g; SAR(10 g) = 1.9 mW/g

Maximum value of SAR (measured) = 4.848 mW/g

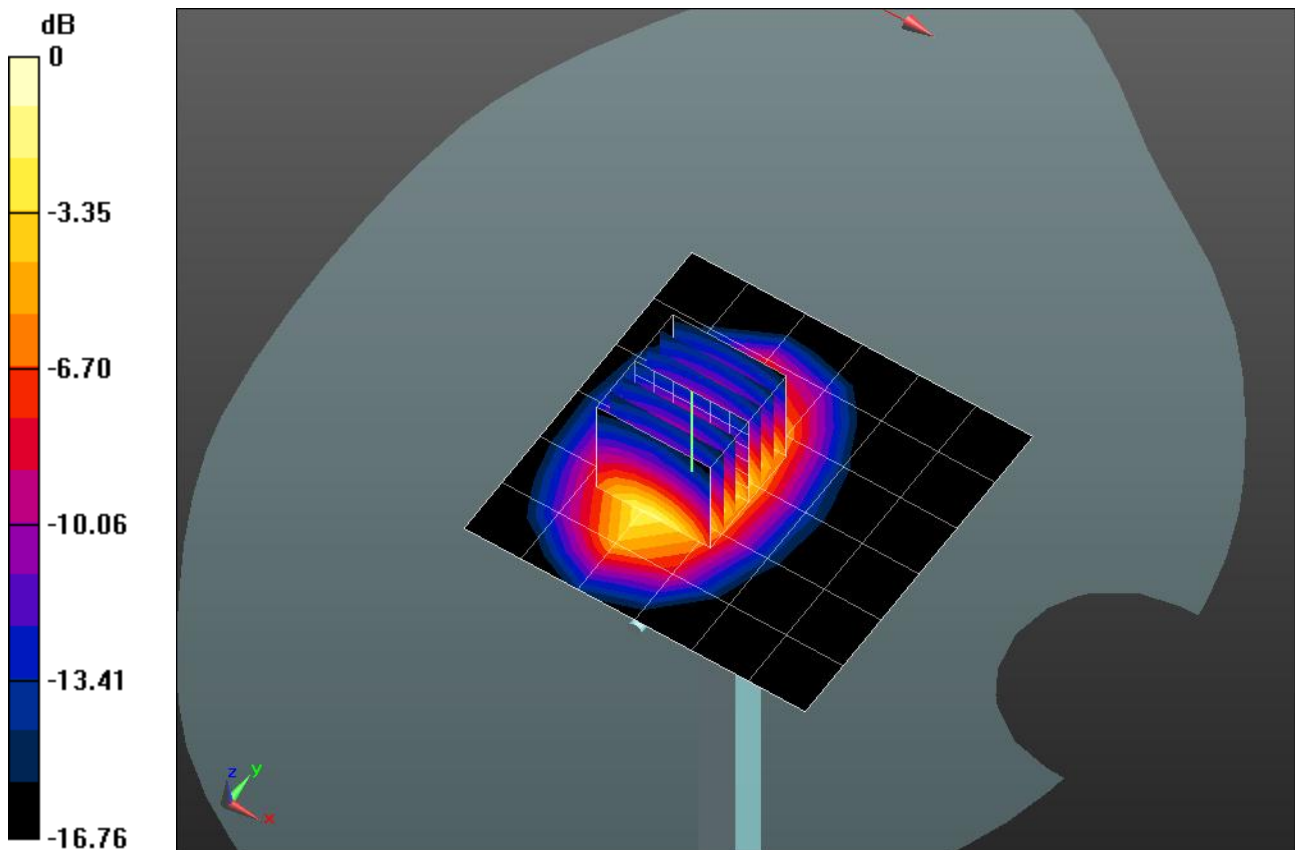

0 dB = 4.850mW/g = 13.71 dB mW/g

20120605_SystemPerformanceCheck-D1750V2 SN 1050

Frequency: 1750 MHz; Duty Cycle: 1:1

Head/Pin=100 mW/Z Scan (1x1x21): Measurement grid: dx=20mm, dy=20mm, dz=5mm
Maximum value of SAR (measured) = 2.199 mW/g

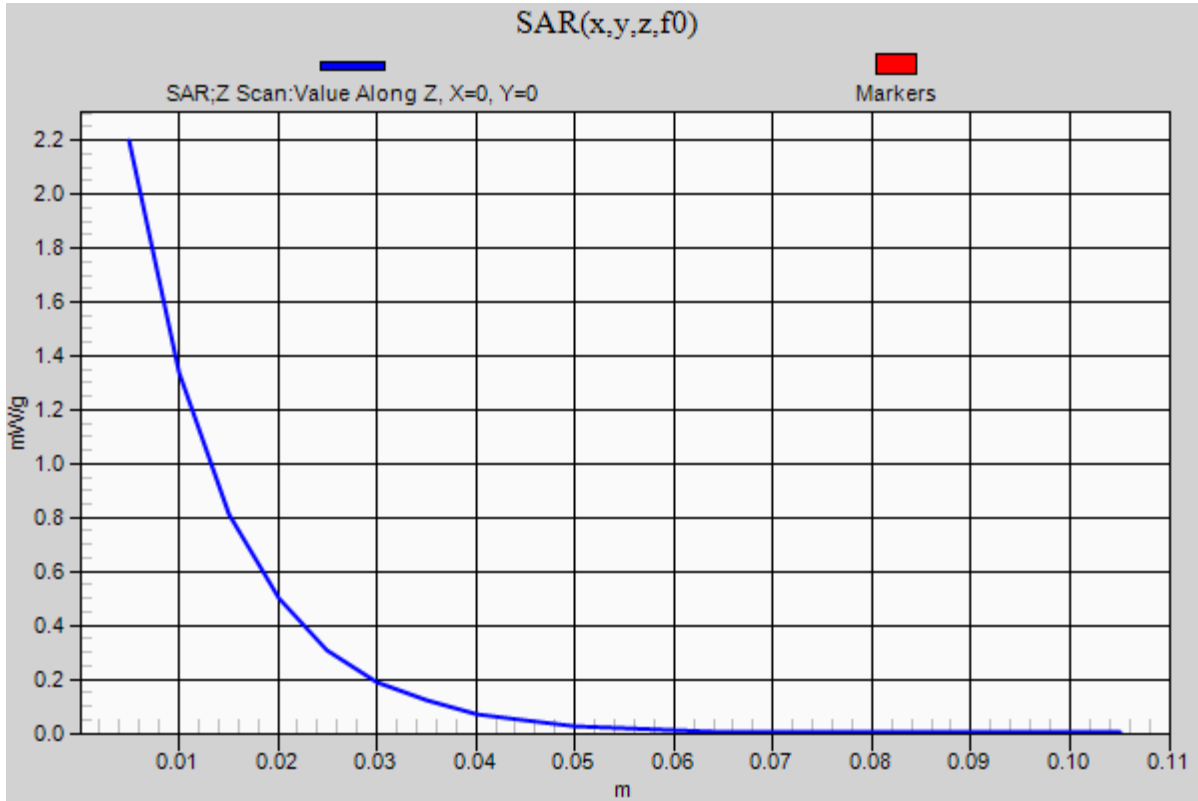

20120606_SystemPerformanceCheck-D1750V2 SN 1050

Frequency: 1750 MHz; Duty Cycle: 1:1; Room Ambient Temperature: 24.0°C; Liquid Temperature: 23.0°C
Medium parameters used: $f = 1750$ MHz; $\sigma = 1.437$ mho/m; $\epsilon_r = 52.881$; $\rho = 1000$ kg/m³

DASY5 Configuration:

- Electronics: DAE4 Sn1259; Calibrated: 2/13/2012
- Probe: EX3DV4 - SN3686; ConvF(7.44, 7.44, 7.44); Calibrated: 2/16/2012
- Sensor-Surface: 2.5mm (Mechanical Surface Detection)
- Phantom: ELI v5.0 (B); Type: QDOVA001BB; Serial: 1118

Body/Pin=100 mW/Area Scan (7x7x1): Measurement grid: dx=15mm, dy=15mm

Maximum value of SAR (measured) = 4.365 mW/g

Body/Pin=100 mW/Zoom Scan (7x7x7)/Cube 0: Measurement grid: dx=5mm, dy=5mm, dz=5mm

Reference Value = 53.139 V/m; Power Drift = 0.13 dB

Peak SAR (extrapolated) = 6.4880

SAR(1 g) = 3.75 mW/g; SAR(10 g) = 2.01 mW/g

Maximum value of SAR (measured) = 4.980 mW/g

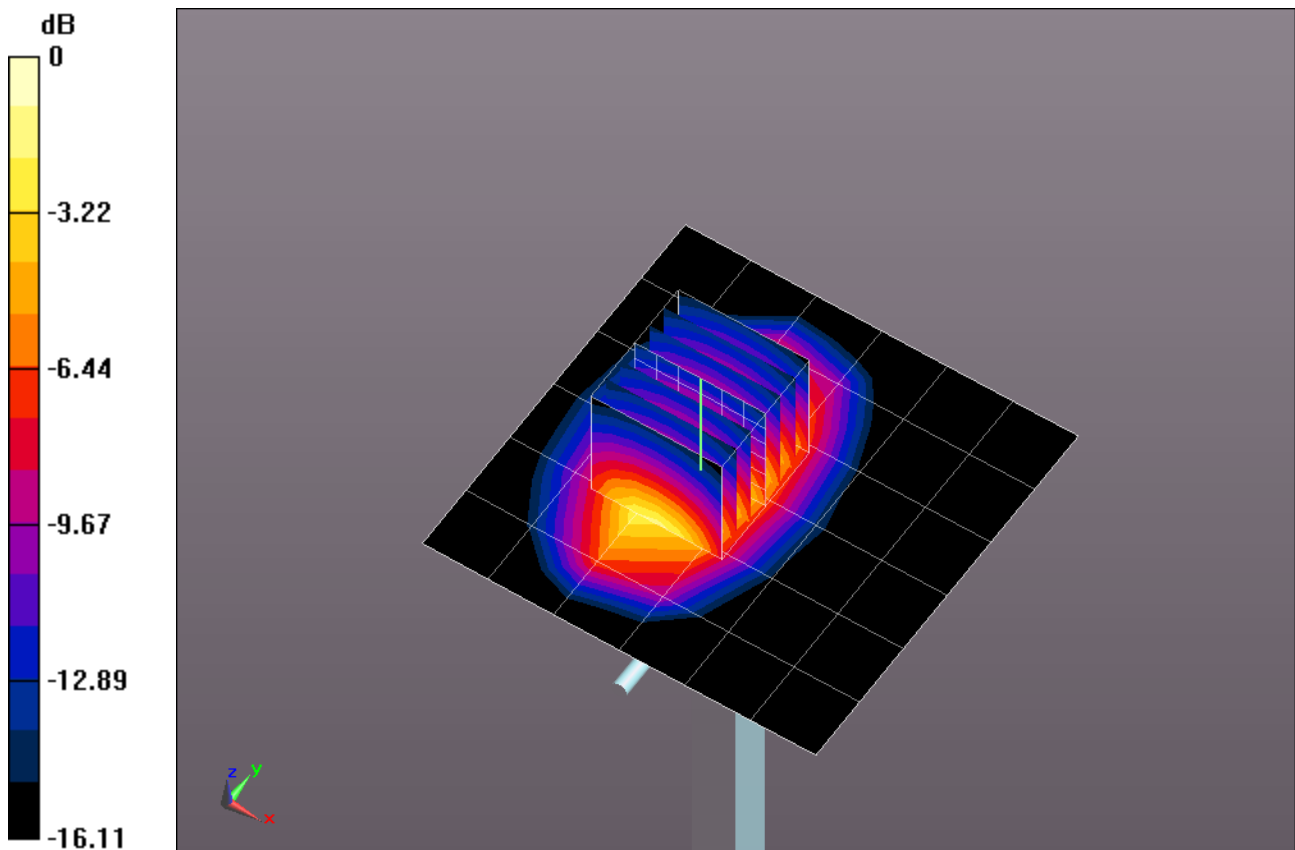

0 dB = 4.980mW/g = 13.94 dB mW/g

20120606_SystemPerformanceCheck-D1750V2 SN 1050

Frequency: 1750 MHz; Duty Cycle: 1:1

Body/Pin=100 mW/Z Scan (1x1x21): Measurement grid: dx=20mm, dy=20mm, dz=5mm
Maximum value of SAR (measured) = 2.940 mW/g

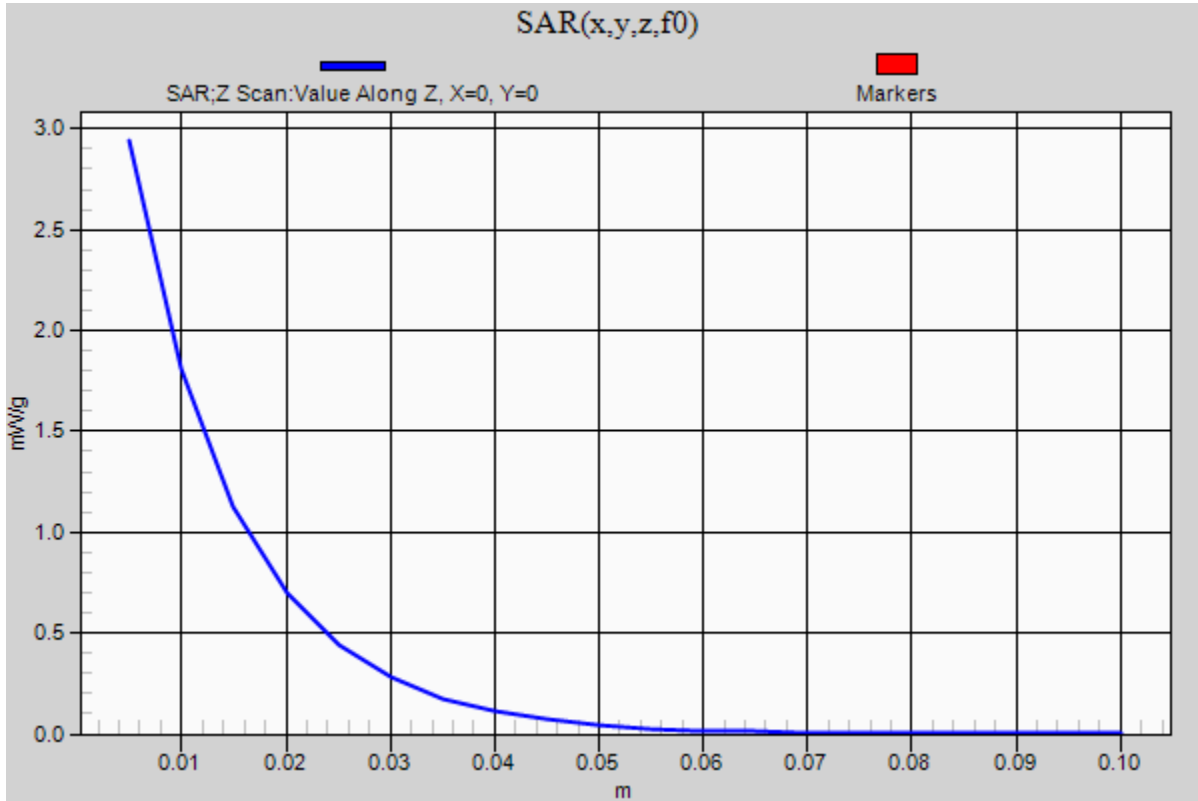

20120607_SystemPerformanceCheck-D1750V2 SN 1050

Frequency: 1750 MHz; Duty Cycle: 1:1; Room Ambient Temperature: 24.0°C; Liquid Temperature: 23.0°C
Medium parameters used: $f = 1750$ MHz; $\sigma = 1.351$ mho/m; $\epsilon_r = 39.291$; $\rho = 1000$ kg/m³

DASY5 Configuration:

- Electronics: DAE4 Sn1259; Calibrated: 2/13/2012
- Probe: EX3DV4 - SN3686; ConvF(7.65, 7.65, 7.65); Calibrated: 2/16/2012
- Sensor-Surface: 2.5mm (Mechanical Surface Detection)
- Phantom: SAM; Type: QD000P40CD; Serial: 1629

Head/Pin=100 mW/Area Scan (7x7x1): Measurement grid: dx=15mm, dy=15mm

Maximum value of SAR (measured) = 4.517 mW/g

Head/Pin=100 mW/Zoom Scan (7x7x7)/Cube 0: Measurement grid: dx=5mm, dy=5mm, dz=5mm

Reference Value = 47.701 V/m; Power Drift = 0.11 dB

Peak SAR (extrapolated) = 6.3960

SAR(1 g) = 3.49 mW/g; SAR(10 g) = 1.85 mW/g

Maximum value of SAR (measured) = 4.659 mW/g

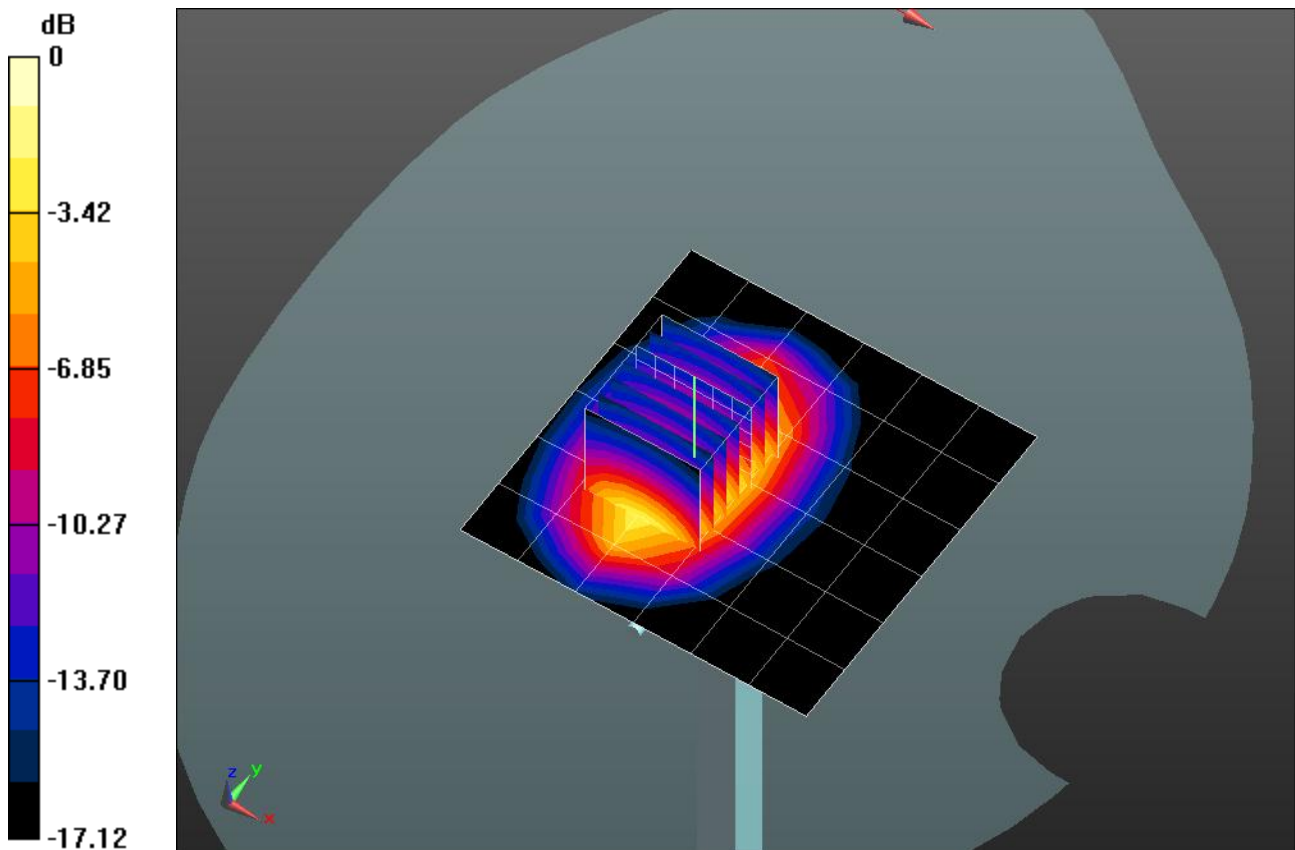

0 dB = 4.660mW/g = 13.37 dB mW/g

20120607_SystemPerformanceCheck-D1750V2 SN 1050

Frequency: 1750 MHz; Duty Cycle: 1:1

Head/Pin=100 mW/Z Scan (1x1x21): Measurement grid: dx=20mm, dy=20mm, dz=5mm
Maximum value of SAR (measured) = 2.068 mW/g

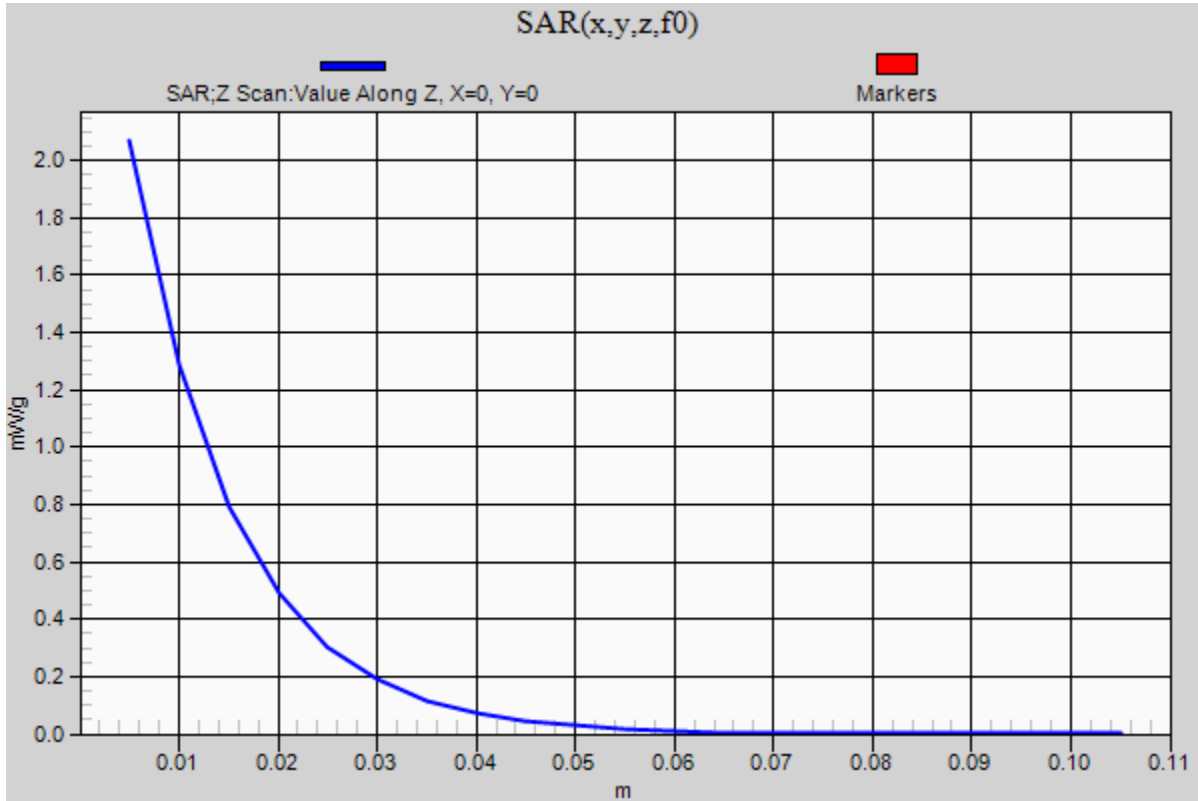

20120608_SystemPerformanceCheck-D1750V2 SN 1050

Frequency: 1750 MHz; Duty Cycle: 1:1; Room Ambient Temperature: 24.0°C; Liquid Temperature: 23.0°C
Medium parameters used: $f = 1750$ MHz; $\sigma = 1.472$ mho/m; $\epsilon_r = 53.259$; $\rho = 1000$ kg/m³

DASY5 Configuration:

- Electronics: DAE4 Sn1259; Calibrated: 2/13/2012
- Probe: EX3DV4 - SN3686; ConvF(7.44, 7.44, 7.44); Calibrated: 2/16/2012
- Sensor-Surface: 2.5mm (Mechanical Surface Detection)
- Phantom: ELI v5.0 (B); Type: QDOVA001BB; Serial: 1118

Body/Pin=100 mW/Area Scan (7x7x1): Measurement grid: dx=15mm, dy=15mm

Maximum value of SAR (measured) = 3.586 mW/g

Body/Pin=100 mW/Zoom Scan (7x7x7)/Cube 0: Measurement grid: dx=5mm, dy=5mm, dz=5mm

Reference Value = 53.447 V/m; Power Drift = 0.09 dB

Peak SAR (extrapolated) = 5.9620

SAR(1 g) = 3.46 mW/g; SAR(10 g) = 1.86 mW/g

Maximum value of SAR (measured) = 4.564 mW/g

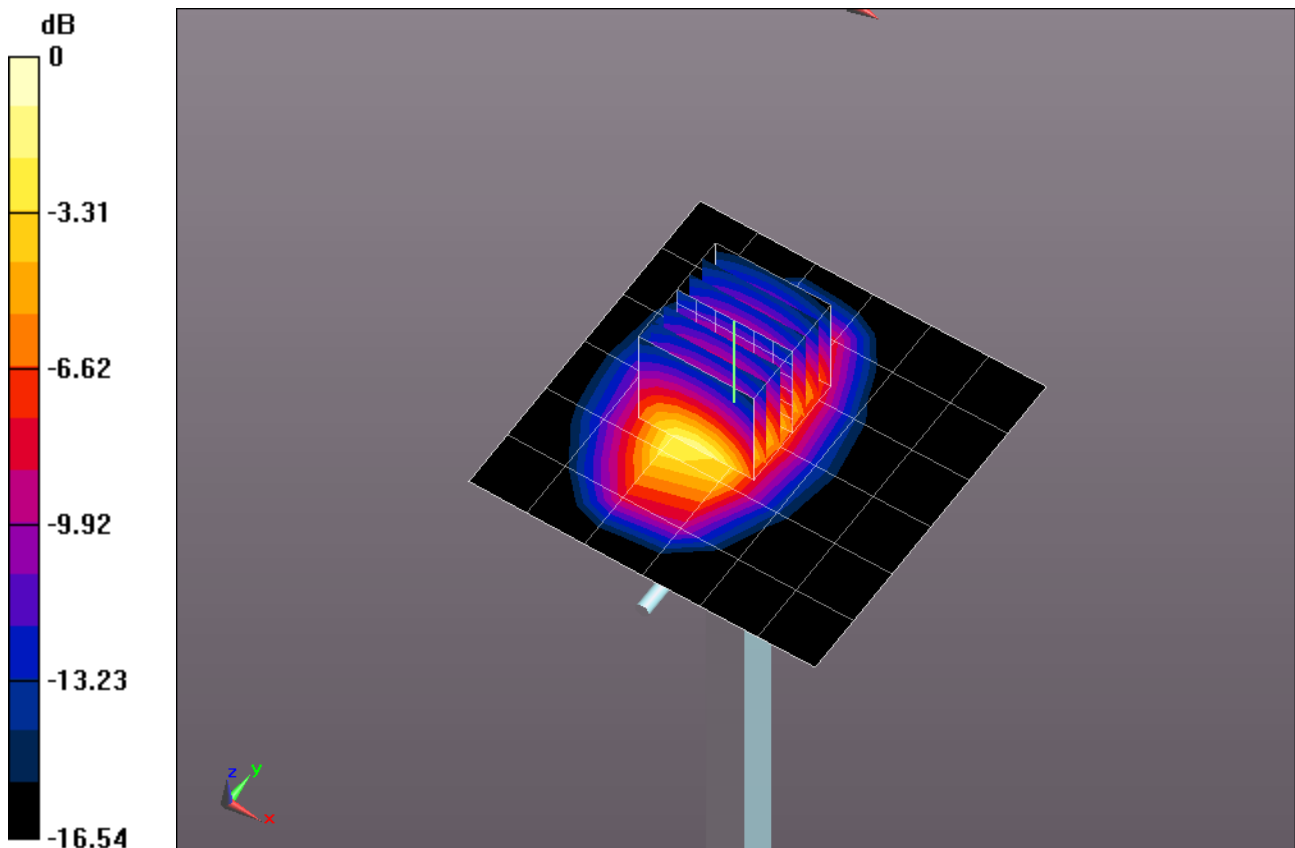

0 dB = 4.560mW/g = 13.18 dB mW/g

20120608_SystemPerformanceCheck-D1750V2 SN 1050

Frequency: 1750 MHz; Duty Cycle: 1:1

Body/Pin=100 mW/Z Scan (1x1x21): Measurement grid: dx=20mm, dy=20mm, dz=5mm
Maximum value of SAR (measured) = 2.737 mW/g

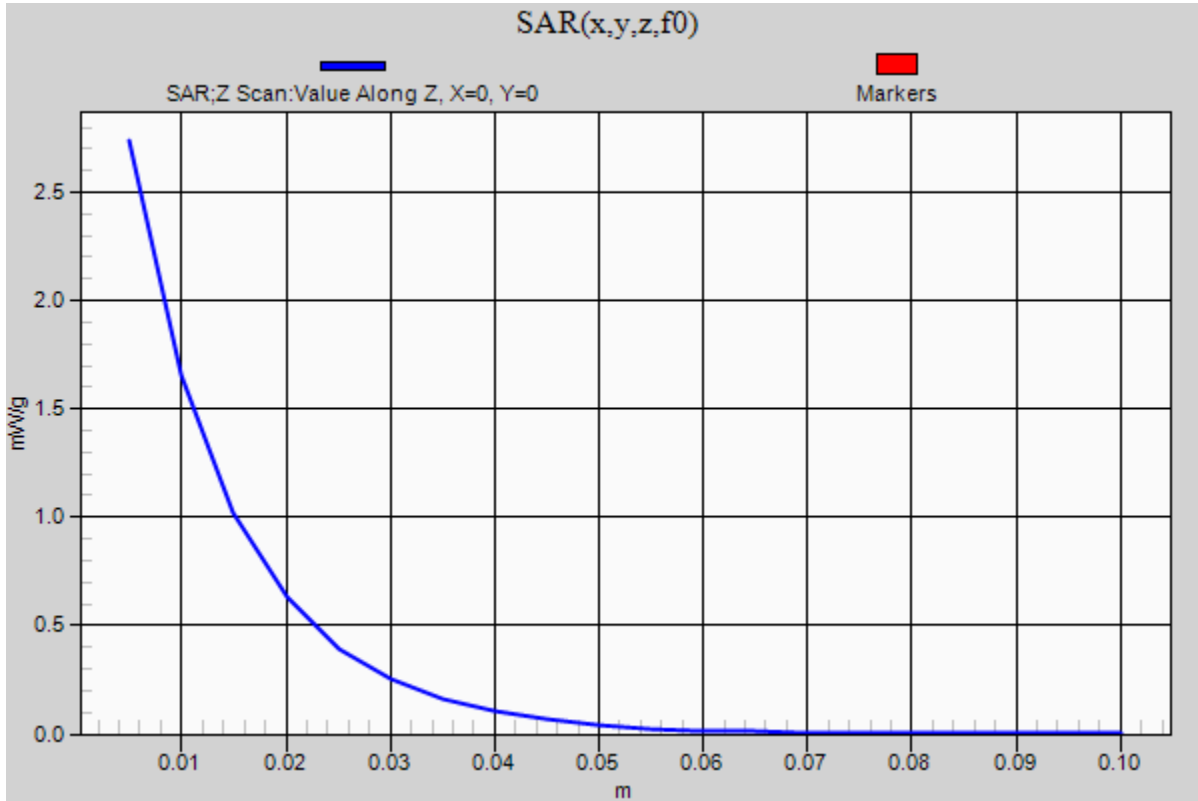

20120608_SystemPerformanceCheck-D2450V2 SN 748

Frequency: 2450 MHz; Duty Cycle: 1:1; Room Ambient Temperature: 24.0°C; Liquid Temperature: 23.0°C

Medium parameters used: $f = 2450$ MHz; $\sigma = 1.803$ mho/m; $\epsilon_r = 40.659$; $\rho = 1000$ kg/m³

DASY5 Configuration:

- Area Scan setting - Find Secondary Maximum Within: 2.0 dB and with a peak SAR value greater than 0.0012W/kg
- Electronics: DAE4 Sn1258; Calibrated: 3/8/2012
- Probe: EX3DV4 - SN3772; ConvF(6.64, 6.64, 6.64); Calibrated: 2/16/2012;
- Sensor-Surface: 2.5mm (Mechanical Surface Detection)
- Phantom: SAM v5.0 (A); Type: QD000P40CC; Serial: 1602

Head/Pin=100 mW/Area Scan (7x7x1): Measurement grid: dx=15mm, dy=15mm

Maximum value of SAR (measured) = 4.82 mW/g

Head/Pin=100 mW/Zoom Scan (7x7x7)/Cube 0: Measurement grid: dx=5mm, dy=5mm, dz=5mm

Reference Value = 62.450 V/m; Power Drift = 0.02 dB

Peak SAR (extrapolated) = 10.695 mW/g

SAR(1 g) = 5.01 mW/g; SAR(10 g) = 2.29 mW/g

Maximum value of SAR (measured) = 7.13 mW/g

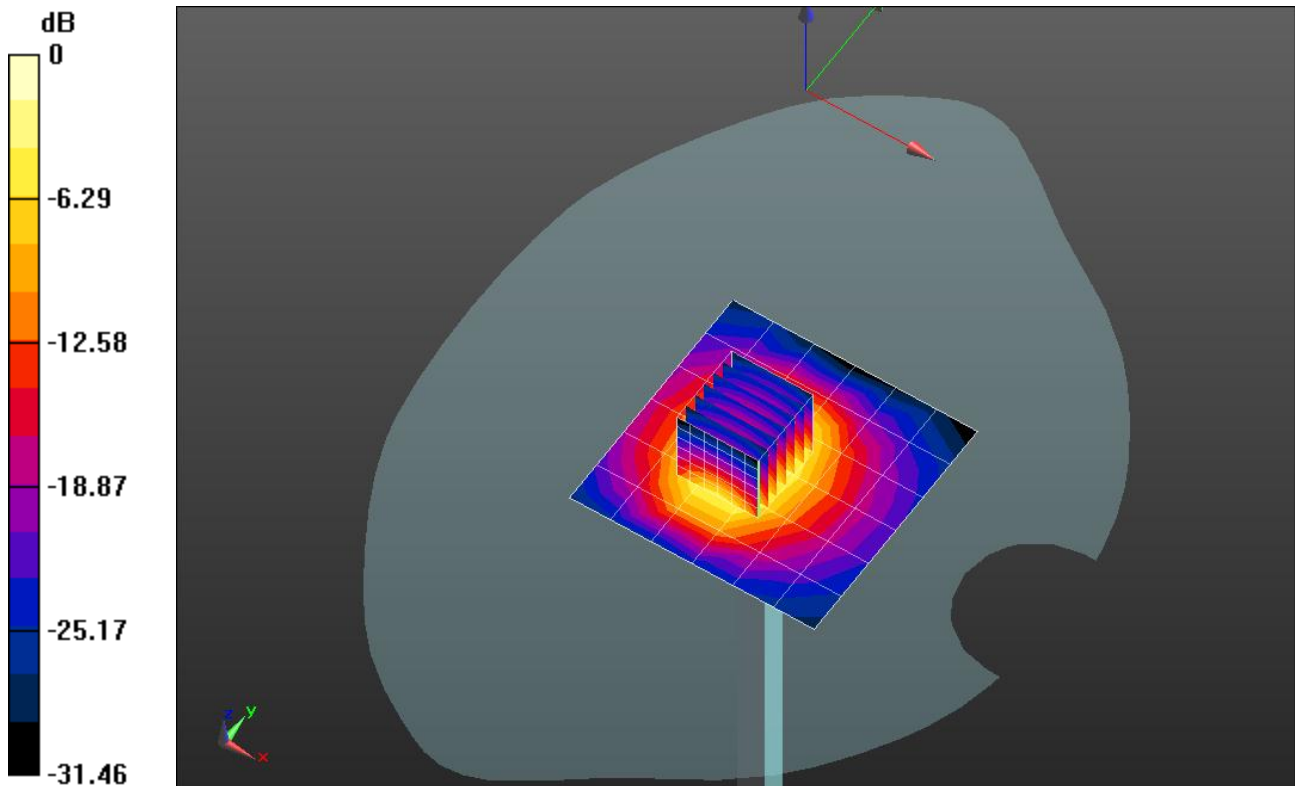

0 dB = 4.82 mW/g = 13.66 dB mW/g

20120608_SystemPerformanceCheck-D2450V2 SN 748

Frequency: 2450 MHz; Duty Cycle: 1:1

Head/Pin=100 mW/Z Scan (1x1x21): Measurement grid: dx=20mm, dy=20mm, dz=5mm
Maximum value of SAR (measured) = 3.25 mW/g

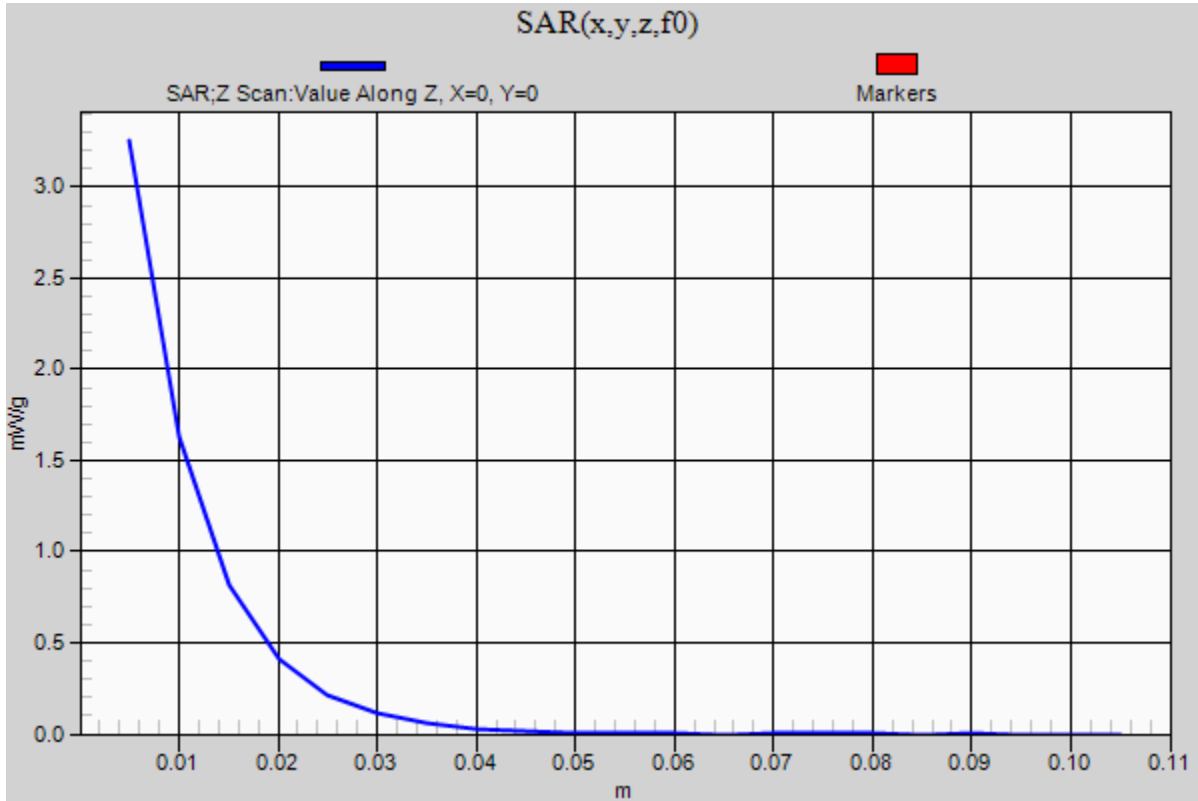

20120608_SystemPerformanceCheck-D2450V2 SN 748

Frequency: 2450 MHz; Duty Cycle: 1:1; Room Ambient Temperature: 24.0°C; Liquid Temperature: 23.0°C
 Medium parameters used: $f = 2450$ MHz; $\sigma = 1.994$ mho/m; $\epsilon_r = 53.921$; $\rho = 1000$ kg/m³

DASY5 Configuration:

- Electronics: DAE4 Sn1258; Calibrated: 3/8/2012
- Probe: EX3DV4 - SN3772; ConvF(6.65, 6.65, 6.65); Calibrated: 2/16/2012
- Sensor-Surface: 2.5mm (Mechanical Surface Detection)
- Phantom: ELI v5.0 (B); Type: QDOVA001BB; Serial: 1099

Body/Pin=100 mW/Area Scan (7x7x1): Measurement grid: dx=15mm, dy=15mm

Maximum value of SAR (measured) = 5.440 mW/g

Body/Pin=100 mW/Zoom Scan (7x7x7)/Cube 0: Measurement grid: dx=5mm, dy=5mm, dz=5mm

Reference Value = 60.210 V/m; Power Drift = 0.02 dB

Peak SAR (extrapolated) = 10.4930

SAR(1 g) = 5.07 mW/g; SAR(10 g) = 2.35 mW/g

Maximum value of SAR (measured) = 7.209 mW/g

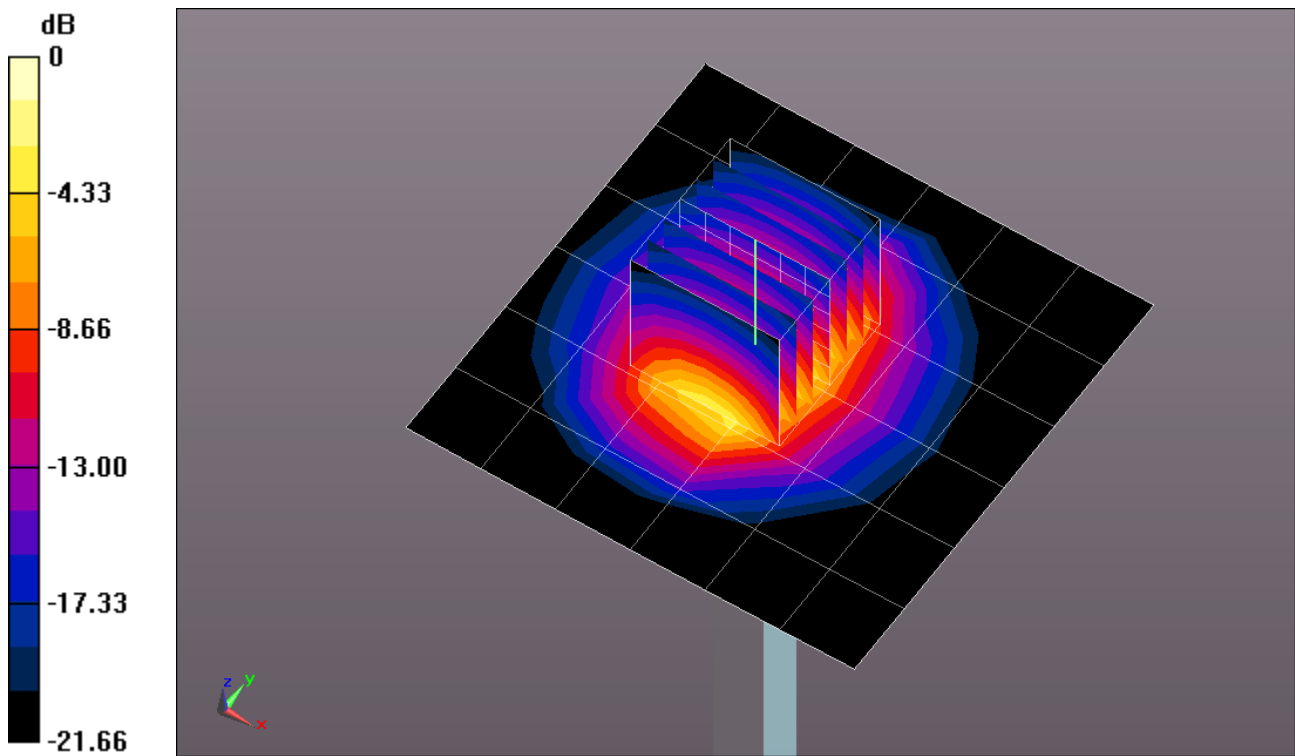

0 dB = 7.210mW/g = 17.16 dB mW/g

20120608_SystemPerformanceCheck-D2450V2 SN 748

Frequency: 2450 MHz; Duty Cycle: 1:1

Body/Pin=100 mW/Z Scan (1x1x21): Measurement grid: dx=20mm, dy=20mm, dz=5mm
Maximum value of SAR (measured) = 5.926 mW/g

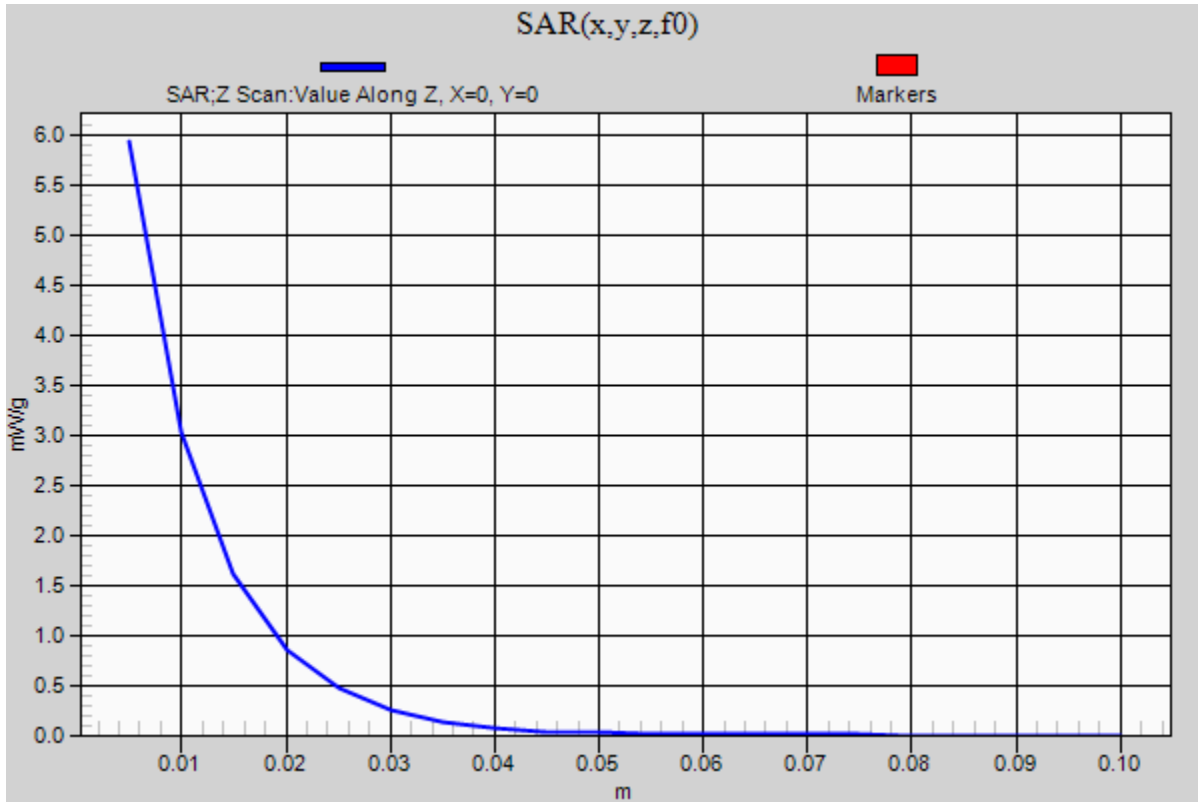

20120608_SystemPerformanceCheck-D835V2 SN 4d002

Frequency: 835 MHz; Duty Cycle: 1:1; Room Ambient Temperature: 24.0°C; Liquid Temperature: 23.0°C
Medium parameters used: $f = 835 \text{ MHz}$; $\sigma = 0.982 \text{ mho/m}$; $\epsilon_r = 54.858$; $\rho = 1000 \text{ kg/m}^3$

DASY5 Configuration:

- Electronics: DAE4 Sn1259; Calibrated: 2/13/2012
- Probe: EX3DV4 - SN3686; ConvF(8.73, 8.73, 8.73); Calibrated: 2/16/2012
- Sensor-Surface: 2.5mm (Mechanical Surface Detection)
- Phantom: ELI v5.0 (A); Type: QDOVA001BB; Serial: 1120

Body/Pin=100 mW/Area Scan (7x7x1): Measurement grid: dx=15mm, dy=15mm

Maximum value of SAR (measured) = 1.040 mW/g

Body/Pin=100 mW/Zoom Scan (7x7x7)/Cube 0: Measurement grid: dx=5mm, dy=5mm, dz=5mm

Reference Value = 34.434 V/m; Power Drift = 0.06 dB

Peak SAR (extrapolated) = 1.4360

SAR(1 g) = 0.974 mW/g; SAR(10 g) = 0.642 mW/g

Maximum value of SAR (measured) = 1.181 mW/g

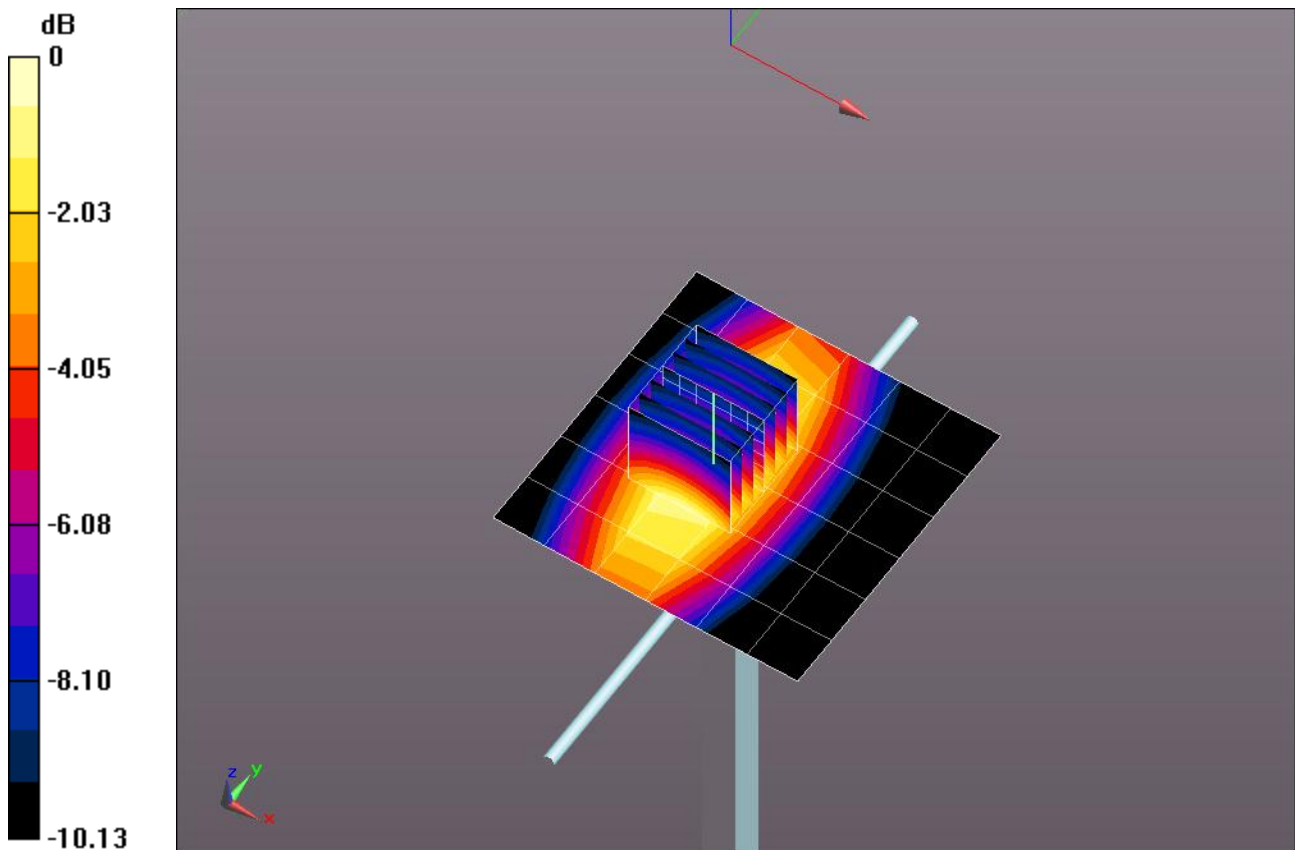

0 dB = 1.180mW/g = 1.44 dB mW/g

20120608_SystemPerformanceCheck-D835V2 SN 4d002

Frequency: 835 MHz; Duty Cycle: 1:1

Body/Pin=100 mW/Z Scan (1x1x21): Measurement grid: dx=20mm, dy=20mm, dz=5mm
Maximum value of SAR (measured) = 0.735 mW/g

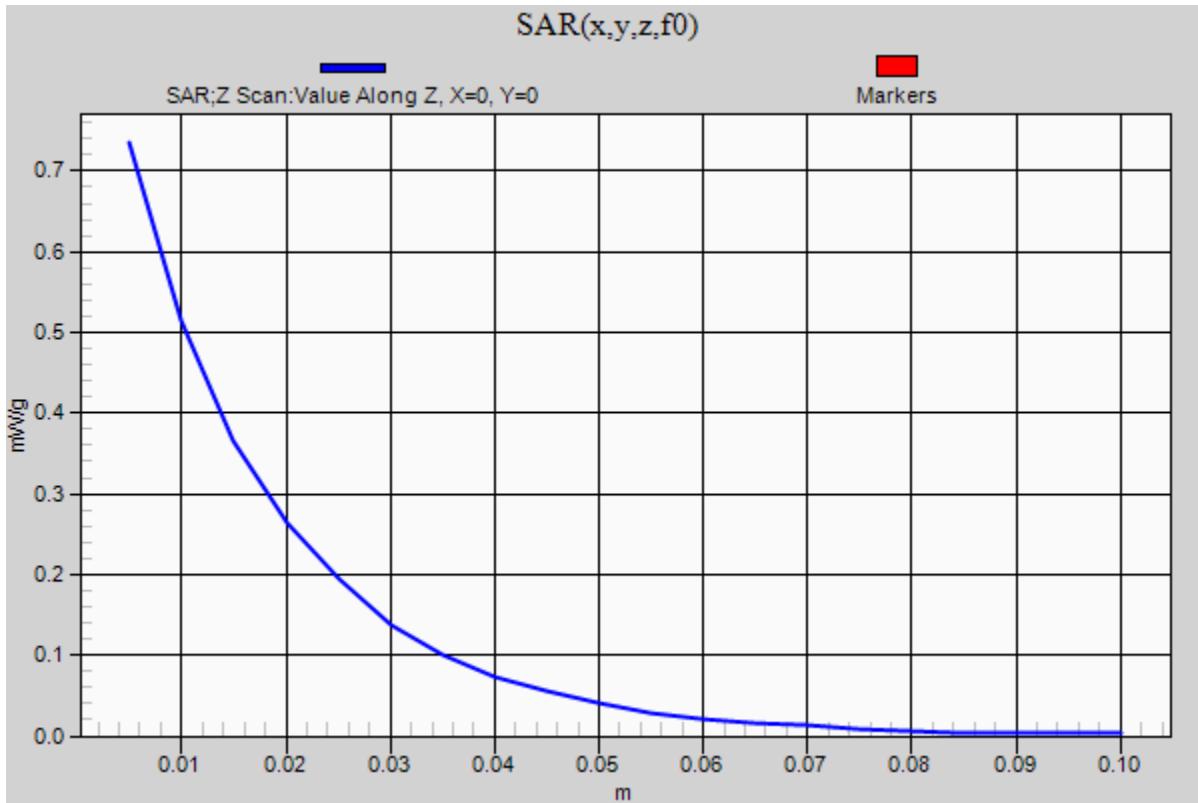

20120608_SystemPerformanceCheck-D1900V2 SN 5d043

Frequency: 1900 MHz; Duty Cycle: 1:1; Room Ambient Temperature: 24.0°C; Liquid Temperature: 23.0°C
Medium parameters used: $f = 1900$ MHz; $\sigma = 1.538$ mho/m; $\epsilon_r = 51.526$; $\rho = 1000$ kg/m³

DASY5 Configuration:

- Electronics: DAE4 Sn1259; Calibrated: 2/13/2012
- Probe: EX3DV4 - SN3686; ConvF(7.04, 7.04, 7.04); Calibrated: 2/16/2012
- Sensor-Surface: 2.5mm (Mechanical Surface Detection)
- Phantom: ELI v5.0 (B); Type: QDOVA001BB; Serial: 1118

Body/Pin=100 mW/Area Scan (7x7x1): Measurement grid: dx=15mm, dy=15mm

Maximum value of SAR (measured) = 4.615 mW/g

Body/Pin=100 mW/Zoom Scan (7x7x7)/Cube 0: Measurement grid: dx=5mm, dy=5mm, dz=5mm

Reference Value = 53.442 V/m; Power Drift = 0.13 dB

Peak SAR (extrapolated) = 7.2950

SAR(1 g) = 4.03 mW/g; SAR(10 g) = 2.11 mW/g

Maximum value of SAR (measured) = 5.454 mW/g

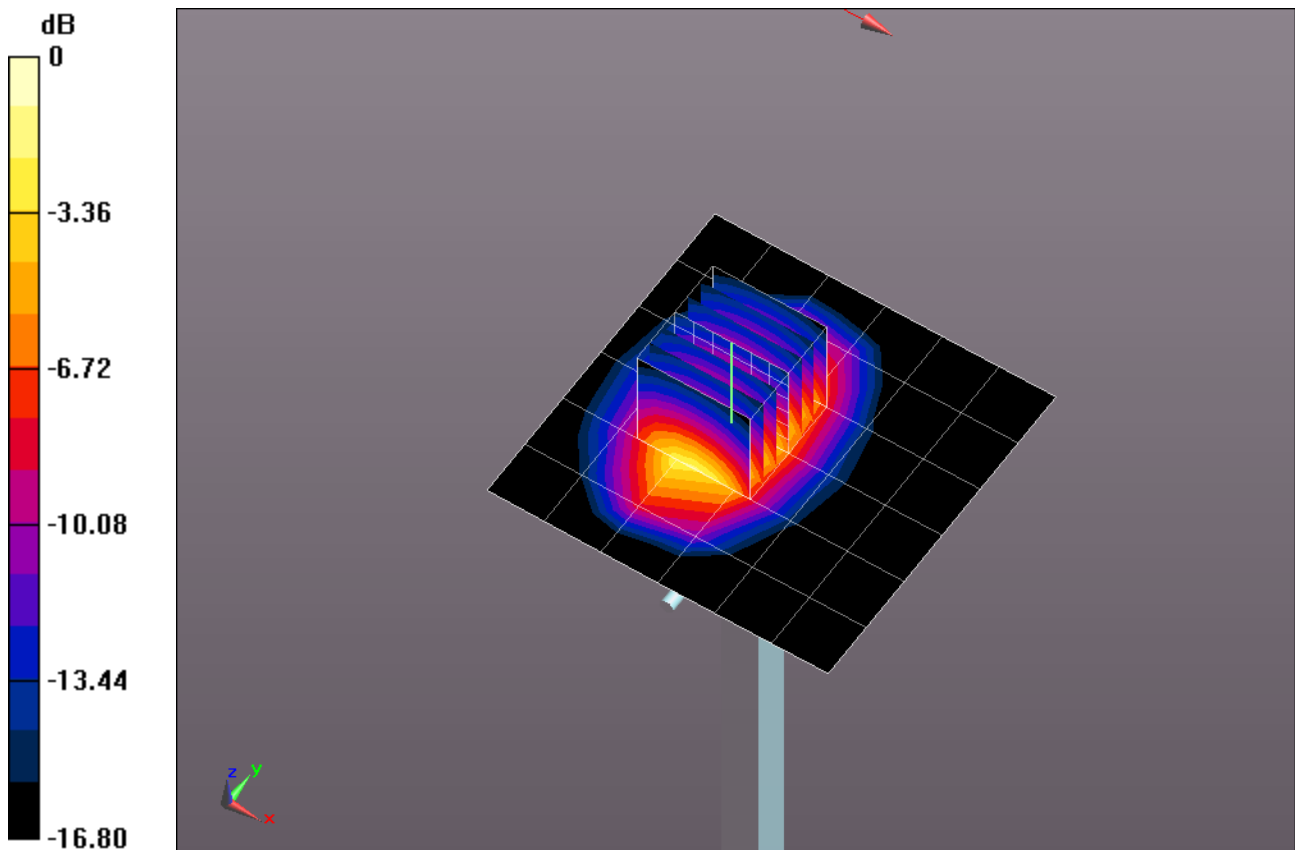

0 dB = 5.450mW/g = 14.73 dB mW/g

20120608_SystemPerformanceCheck-D1900V2 SN 5d043

Frequency: 1900 MHz; Duty Cycle: 1:1

Body/Pin=100 mW/Z Scan (1x1x21): Measurement grid: dx=20mm, dy=20mm, dz=5mm
Maximum value of SAR (measured) = 2.468 mW/g

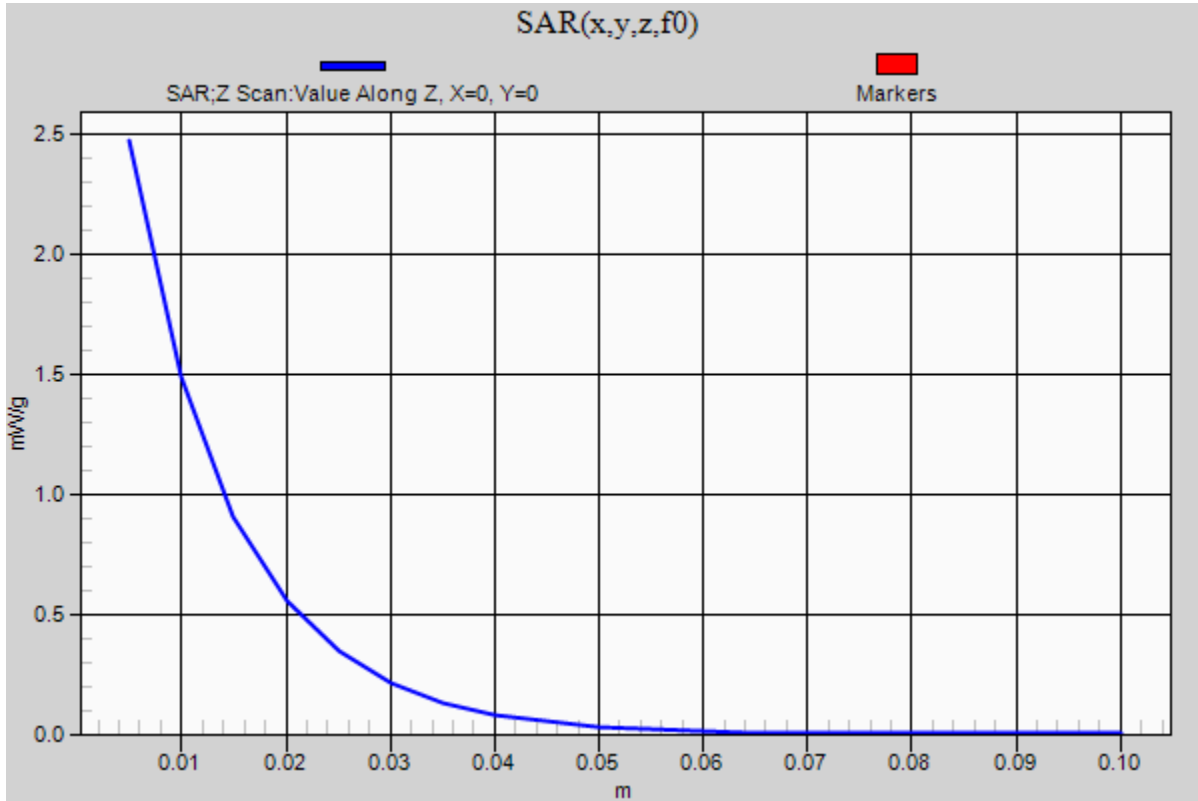

20120609_SystemPerformanceCheck-D835V2 SN 4d002

Frequency: 835 MHz; Duty Cycle: 1:1; Room Ambient Temperature: 24.0°C; Liquid Temperature: 23.0°C

Medium parameters used: $f = 835 \text{ MHz}$; $\sigma = 0.88 \text{ mho/m}$; $\epsilon_r = 42.026$; $\rho = 1000 \text{ kg/m}^3$

DASY5 Configuration:

- Electronics: DAE4 Sn1258; Calibrated: 3/8/2012
- Probe: EX3DV4 - SN3772; ConvF(8.67, 8.67, 8.67); Calibrated: 2/16/2012
- Sensor-Surface: 2.5mm (Mechanical Surface Detection)
- Phantom: SAM v5.0 (B); Type: QD000P40CD; Serial: 1628

Head/Pin=100 mW/Area Scan (7x7x1): Measurement grid: $dx=15\text{mm}$, $dy=15\text{mm}$

Maximum value of SAR (measured) = 1.029 mW/g

Head/Pin=100 mW/Zoom Scan (7x7x7)/Cube 0: Measurement grid: $dx=5\text{mm}$, $dy=5\text{mm}$, $dz=5\text{mm}$

Reference Value = 36.973 V/m; Power Drift = -0.11 dB

Peak SAR (extrapolated) = 1.4490

SAR(1 g) = 0.959 mW/g; SAR(10 g) = 0.627 mW/g

Maximum value of SAR (measured) = 1.173 mW/g

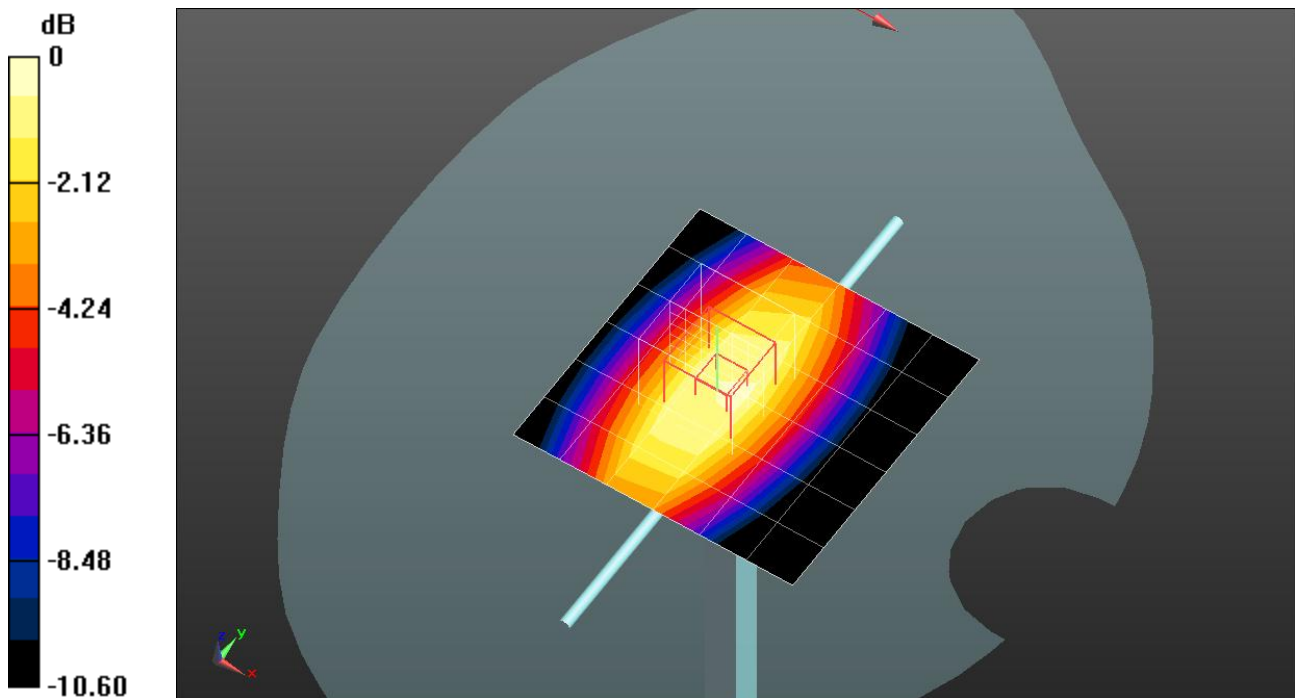

0 dB = 1.170mW/g = 1.36 dB mW/g

20120609_SystemPerformanceCheck-D835V2 SN 4d002

Frequency: 835 MHz; Duty Cycle: 1:1

Head/Pin=100 mW/Z Scan (1x1x21): Measurement grid: dx=20mm, dy=20mm, dz=5mm
Maximum value of SAR (measured) = 0.811 mW/g

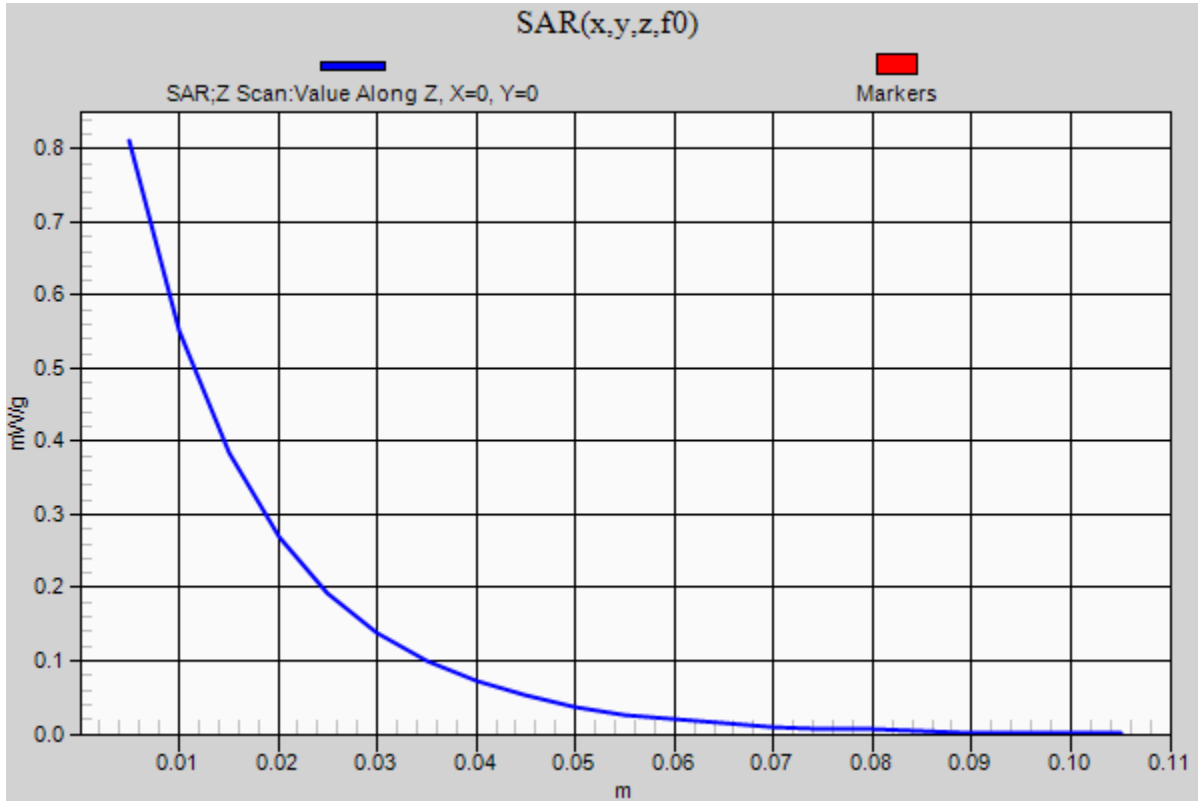

20120609_SystemPerformanceCheck-D1900V2 SN 5d043

Frequency: 1900 MHz; Duty Cycle: 1:1; Room Ambient Temperature: 24.0°C; Liquid Temperature: 23.0°C
Medium parameters used: $f = 1900$ MHz; $\sigma = 1.415$ mho/m; $\epsilon_r = 40.544$; $\rho = 1000$ kg/m³

DASY5 Configuration:

- Electronics: DAE4 Sn1259; Calibrated: 2/13/2012
- Probe: EX3DV4 - SN3686; ConvF(7.51, 7.51, 7.51); Calibrated: 2/16/2012
- Sensor-Surface: 2.5mm (Mechanical Surface Detection)
- Phantom: SAM; Type: QD000P40CD; Serial: 1629

Head/Pin=100 mW/Area Scan (7x7x1): Measurement grid: dx=15mm, dy=15mm

Maximum value of SAR (measured) = 4.889 mW/g

Head/Pin=100 mW/Zoom Scan (7x7x7)/Cube 0: Measurement grid: dx=5mm, dy=5mm, dz=5mm

Reference Value = 54.924 V/m; Power Drift = 0.04 dB

Peak SAR (extrapolated) = 7.5940

SAR(1 g) = 4.01 mW/g; SAR(10 g) = 2.08 mW/g

Maximum value of SAR (measured) = 5.472 mW/g

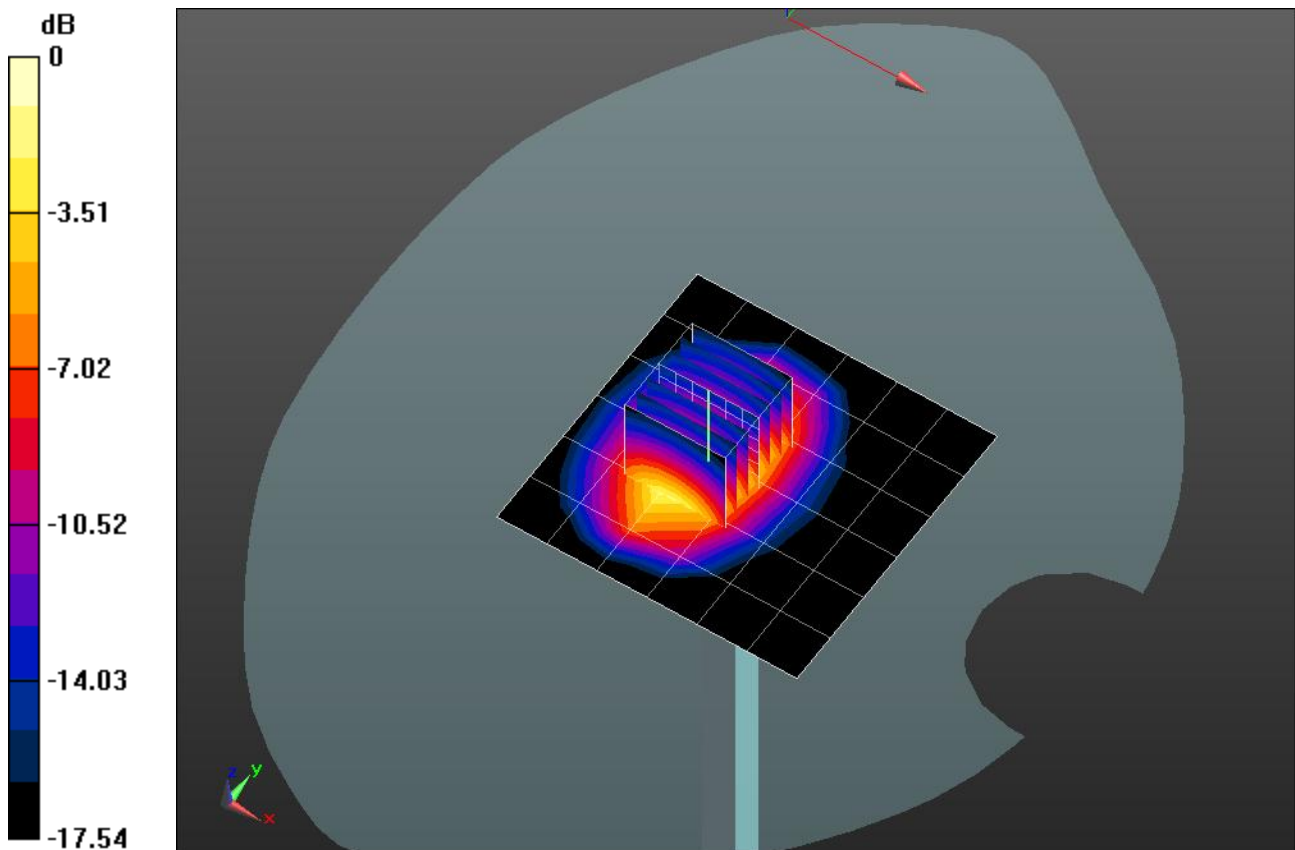

0 dB = 5.470mW/g = 14.76 dB mW/g

20120609_SystemPerformanceCheck-D1900V2 SN 5d043

Frequency: 1900 MHz; Duty Cycle: 1:1

Head/Pin=100 mW/Z Scan (1x1x21): Measurement grid: dx=20mm, dy=20mm, dz=5mm
Maximum value of SAR (measured) = 2.720 mW/g

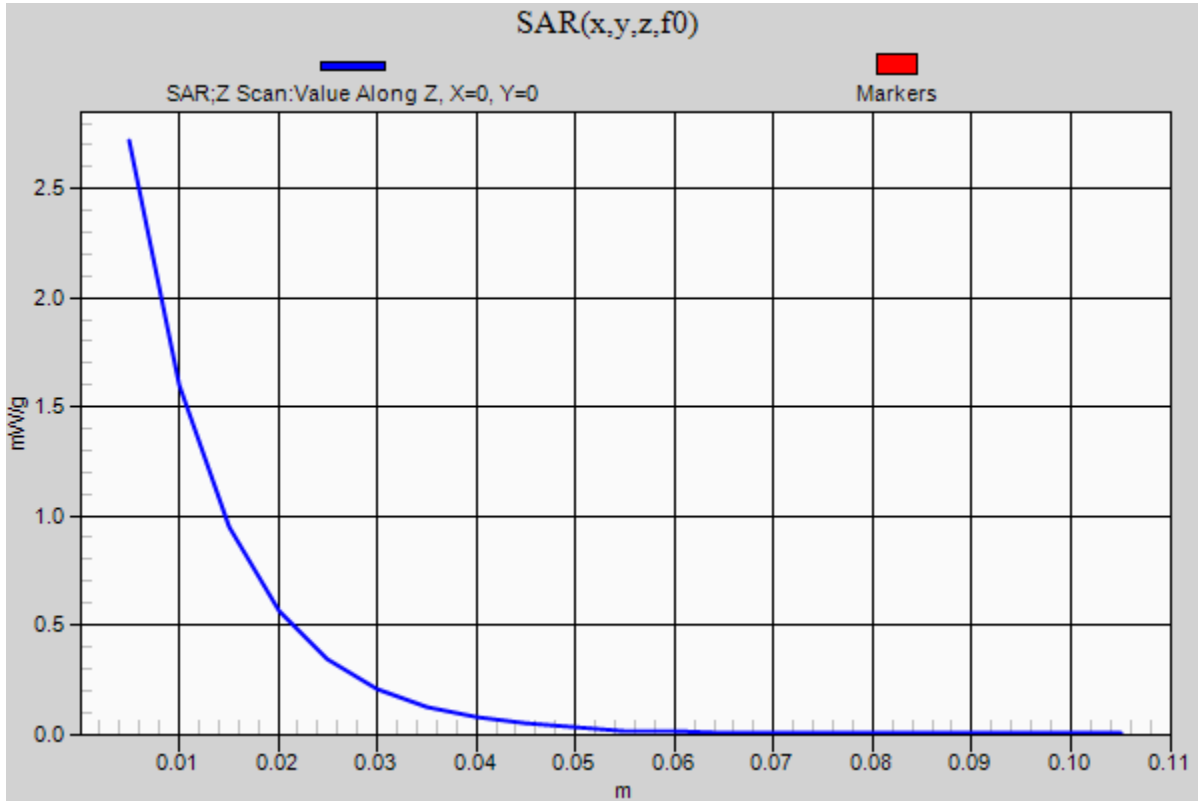

20120615_SystemPerformanceCheck-D1900V2 SN 5d043

Frequency: 1900 MHz; Duty Cycle: 1:1; Room Ambient Temperature: 24.0°C; Liquid Temperature: 23.0°C
Medium parameters used: $f = 1900$ MHz; $\sigma = 1.567$ mho/m; $\epsilon_r = 51.357$; $\rho = 1000$ kg/m³

DASY5 Configuration:

- Electronics: DAE4 Sn1259; Calibrated: 2/13/2012
- Probe: EX3DV4 - SN3686; ConvF(7.04, 7.04, 7.04); Calibrated: 2/16/2012
- Sensor-Surface: 2.5mm (Mechanical Surface Detection)
- Phantom: ELI v5.0 (B); Type: QDOVA001BB; Serial: 1118

Body/Pin=100 mW/Area Scan (7x7x1): Measurement grid: dx=15mm, dy=15mm

Maximum value of SAR (measured) = 4.422 mW/g

Body/Pin=100 mW/Zoom Scan (7x7x7)/Cube 0: Measurement grid: dx=5mm, dy=5mm, dz=5mm

Reference Value = 56.618 V/m; Power Drift = 0.11 dB

Peak SAR (extrapolated) = 7.6020

SAR(1 g) = 4.2 mW/g; SAR(10 g) = 2.2 mW/g

Maximum value of SAR (measured) = 5.660 mW/g

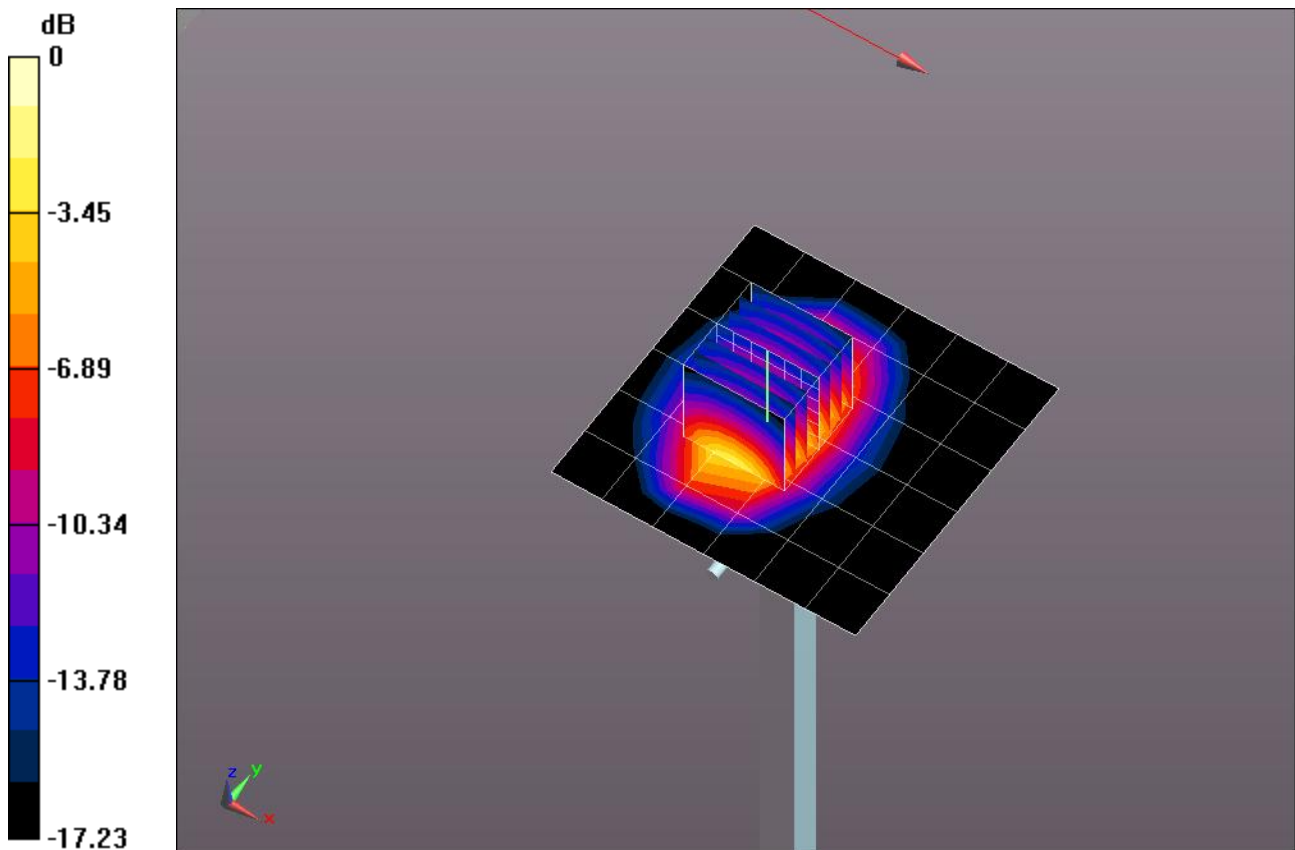

0 dB = 5.660mW/g = 15.06 dB mW/g

20120615_SystemPerformanceCheck-D1900V2 SN 5d043

Frequency: 1900 MHz; Duty Cycle: 1:1

Body/Pin=100 mW/Z Scan (1x1x21): Measurement grid: dx=20mm, dy=20mm, dz=5mm
Maximum value of SAR (measured) = 3.539 mW/g

