



**FCC OET BULLETIN 65 SUPPLEMENT C 01-01
IEEE Std 1528-2003**

SAR EVALUATION REPORT

For

**Cellular/PCS CDMA/EVDO/GSM/GPRS/EDGE, PCS WCDMA/HSPA and AWS LTE Phone with
Bluetooth, WLAN, & NFC**

**Model: LG-VS950, VS950, LGVS950
FCC ID: ZNFVS950**

**Report Number: 12U14390-5B
Issue Date: 5/25/2012**

Prepared for

**LG ELECTRONICS MOBILECOMM U.S.A., INC.
1000 SYLVAN AVENUE
ENGLEWOOD CLIFFS, NJ 07632**

Prepared by

**COMPLIANCE CERTIFICATION SERVICES (UL CCS)
47173 BENICIA STREET
FREMONT, CA 94538, U.S.A.
TEL: (510) 771-1000
FAX: (510) 661-0888**



NVLAP LAB CODE 200065-0

Revision History

<u>Rev.</u>	<u>Issue Date</u>	<u>Revisions</u>	<u>Revised By</u>
--	5/15/2012	Initial Issue	--
A	5/15/2012	1. Updated client address 2. Updated Model Name 3. Revised Tune-up Tolerance	Bobby Bayani
B	5/25/2012	1. Sec. 1: Updated client address 2. Sec. 7: Updated Summary of highest 1-g SAR value	Bobby Bayani

Table of Contents

1. Attestation of Test Results..... 6

2. Test Methodology 7

3. Facilities and Accreditation 7

4. Calibration and Uncertainty 8

 4.1. *Measuring Instrument Calibration 8*

 4.2. *Measurement Uncertainty..... 9*

5. Measurement System Description and Setup..... 10

6. SAR Measurement Procedure..... 11

 6.1. *Normal SAR Measurement Procedure..... 11*

 6.2. *Volume Scan Procedures 12*

7. Summary of Highest 1-g SAR 13

8. Device Under Test..... 14

 8.1. *Band and Air Interfaces 14*

 8.2. *Hotspot (Wireless router) Exposure Condition 14*

 8.3. *Simultaneous Transmission..... 15*

 8.4. *KDB 941225 D05 SAR for LTE Devices v01..... 16*

9. Summary of Test Configurations..... 18

 9.1. *Head Exposure Condition for WWAN, LTE and WiFi..... 18*

 9.2. *Body Exposure Conditions for GSM850/1900/W-CDMA Band II/CDMA (BC0/BC1) 1xRTT..... 18*

 9.3. *Body Exposure Conditions for CDMA (BC0/BC1), 1xEVDO..... 18*

 9.4. *Body Exposure Conditions for LTE Band 13..... 19*

 9.5. *Body Exposure Conditions for WiFi..... 19*

10. RF Output Power Measurement 20

 10.1. *GSM850..... 20*

 10.2. *GSM1900..... 21*

 10.3. *W-CDMA Band II..... 22*

 10.4. *CDMA BC0..... 26*

 10.5. *CDMA BC1..... 27*

 10.6. *LTE Band 13..... 28*

 10.7. *Power Reduction for SV-DO..... 30*

 10.8. *Power Reduction for SV-LTE Band 13 30*

 10.9. *Wi-Fi (2.4 GHz) 31*

10.10. Bluetooth..... 31

11. Tissue Dielectric Properties 32

11.1. Composition of Ingredients for the Tissue Material Used in the SAR Tests 33

11.2. Tissue Dielectric Parameter Check Results..... 34

12. System Performance Check 36

12.1. System Performance Check Measurement Conditions..... 36

12.2. Reference SAR Values for System Performance Check..... 36

12.3. System Performance Check Results 37

13. SAR Test Results 38

13.1. GSM850..... 38

13.1.1. Head SAR 38

13.1.2. Body SAR 38

13.2. GSM1900..... 39

13.2.1. Head SAR 39

13.2.2. Body SAR 39

13.3. W-CDMA Band II..... 40

13.3.1. Head SAR 40

13.3.2. Body & Hotspot SAR 40

13.4. CDMA BC0..... 41

13.4.1. Head SAR 41

13.4.2. Body & Hotspot SAR 42

13.5. CDMA BC1..... 43

13.5.1. Head SAR 43

13.5.2. Body & Hotspot SAR 44

13.6. LTE Band 13..... 45

13.6.1. Head SAR 45

13.6.2. Body & Hotspot SAR 46

13.7. Wi-Fi (2.4 GHz Band) 47

13.7.1. Head SAR 47

13.7.2. Body & Hotspot SAR 47

14. Summary of Highest SAR Values..... 48

14.1. SAR Plots (from Summary of Highest SAR Values) 49



15. Simultaneous Transmission SAR Analysis..... 85

15.1. Head Exposure Conditions..... 85

15.1.1. Sum of the SAR for GSM, W-CDMA, & WiFi 85

15.1.2.	Sum of the SAR for SV-DO & WiFi.....	86
15.1.3.	Sum of the SAR for SV-LTE & WiFi.....	87
15.2.	<i>Body Exposure Conditions</i>	88
15.2.1.	Sum of the SAR for WCDMA & WiFi	88
15.2.2.	Sum of the SAR for SV-DO & WiFi.....	89
15.2.3.	Sum of the SAR for SV-LTE & WiFi.....	90
15.3.	<i>SAR Peak Location Separation Distance Calculations and Figures</i>	91
15.4.	<i>Multi-Band Volume Scan Combined Results</i>	101
16.	Appendixes	102
16.1.	<i>System Performance Check Plots</i>	102
16.2.	<i>SAR Test Plots for GSM850</i>	102
16.3.	<i>SAR Test Plots for GSM1900</i>	102
16.4.	<i>SAR Test Plots for W-CDMA (UMTS) Band II</i>	102
16.5.	<i>SAR Test Plots for CDMA BC0</i>	102
16.6.	<i>SAR Test Plots for CDMA BC1</i>	102
16.7.	<i>SAR Test Plots for LTE Band 13</i>	102
16.8.	<i>SAR Test Plots for WiFi 2.4 GHz Band</i>	102
16.9.	<i>SAR test plots for SV-LTE Volume Scans</i>	102
16.10.	<i>SAR test plots for SV-LTE Multi band results</i>	102
16.11.	<i>Calibration Certificate for E-Field Probe EX3DV4 - SN 3773</i>	102
16.12.	<i>Calibration Certificate for D750V3 - SN 1019</i>	102
16.13.	<i>Calibration Certificate for D835V2 - SN 4d002</i>	102
16.14.	<i>Calibration Certificate for D1900V2 - SN 5d043</i>	102
16.15.	<i>Calibration Certificate for D2450V2 - SN 748</i>	102
17.	External Photos	103
18.	Antenna Locations & Separation Distances	104
19.	Setup Photos	106

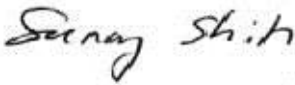
1. Attestation of Test Results

Applicant	LG ELECTRONICS MOBILECOMM U.S.A., INC.	
DUT description	Cellular/PCS CDMA/EVDO/GSM/GPRS/EDGE, PCS WCDMA/HSPA and AWS LTE Phone with Bluetooth, WLAN, & NFC	
Model	LG-VS950, VS950, LGVS950	
Test device is	An identical prototype	
Device category	Portable	
Exposure category	General Population/Uncontrolled Exposure	
Highest 1-g SAR	Refer to Sec. 7 Summary of Highest 1-g SAR	
Date tested	4/25/2012 – 5/4/2012	
	Applicable Standards	Test Results
	FCC OET Bulletin 65 Supplement C 01-01, IEEE Std 1528-2003	Pass
<p>Compliance Certification Services, Inc. (UL CCS) tested the above equipment in accordance with the requirements set forth in the above standards. All indications of Pass/Fail in this report are opinions expressed by UL CCS based on interpretations and/or observations of test results. Measurement Uncertainties were not taken into account and are published for informational purposes only. The test results show that the equipment tested is capable of demonstrating compliance with the requirements as documented in this report.</p> <p>Note: The results documented in this report apply only to the tested sample, under the conditions and modes of operation as described herein. This document may not be altered or revised in any way unless done so by UL CCS and all revisions are duly noted in the revisions section. Any alteration of this document not carried out by UL CCS will constitute fraud and shall nullify the document. This report must not be used by the client to claim product certification, approval, or endorsement by NVLAP, NIST, any agency of the Federal Government, or any agency of any government (NIST Handbook 150, Annex A). This report is written to support regulatory compliance of the applicable standards stated above.</p>		
Approved & Released For UL CCS By:		Tested By:
		
Sunny Shih Engineering Leader Compliance Certification Services (UL CCS)		Bobby Bayani SAR Engineer Compliance Certification Services (UL CCS)

2. Test Methodology

The tests documented in this report were performed in accordance with FCC OET Bulletin 65 Supplement C Edition 01-01, IEEE STD 1528-2003 and the following KDB Procedures:

- 648474 D01 SAR Handsets Multi Xmitter and Ant, v01r05
- 248227 D01 SAR meas for 802 11abg v01r02
- 941225 D01 SAR test for 3G devices v02
- 941225 D03 SAR Test Reduction GSM GPRS EDGE v01
- 941225 D05 SAR for LTE Devices v01
- 941225 D06 Hot Spot SAR v01
- PBA: 181634

3. Facilities and Accreditation

The test sites and measurement facilities used to collect data are located at 47173 Benicia Street, Fremont, California, USA.

UL CCS is accredited by NVLAP, Laboratory Code 200065-0. The full scope of accreditation can be viewed at <http://www.ccsemc.com>.

4. Calibration and Uncertainty

4.1. Measuring Instrument Calibration

The measuring equipment used to perform the tests documented in this report has been calibrated in accordance with the manufacturers' recommendations, and is traceable to recognized national standards.

Name of Equipment	Manufacturer	Type/Model	Serial No.	Cal. Due date		
				MM	DD	Year
Dielectronic Probe kit	HP	85070C	N/A	N/A		
Base Station Simulator	Agilent	8960	GB46160222	6	17	2012
Base Station Simulator	R & S	CMU200	54-1005296	6	24	2012
Base Station Simulator	R & S	CMW500	10-300233773	12	14	2012
ESA Series Network Analyzer	Agilent	E5071B	MY42100131	2	11	2013
Synthesized Signal Generator	HP	83732B	US34490599	7	14	2012
E-Field Probe	SPEAG	EX3DV4	3773	3	14	2013
Thermometer	ERTCO	639-1S	1718	7	19	2012
Data Acquisition Electronics	SPEAG	DAE3	500	7	14	2012
System Validation Dipole	SPEAG	D750V3	1019	2	9	2013
System Validation Dipole	SPEAG	D835V2	4d002	3	6	2013
System Validation Dipole	SPEAG	D1900V2	5d043	11	10	2012
System Validation Dipole	SPEAG	D2450V2	748	2	7	2013
Power Meter	HP	437B	3125U16345	5	13	2012
Power Sensor	HP	8481A	2702A60780	5	13	2012
Amplifier	MITEQ	4D00400600-50-30P	1620606	N/A		
Directional coupler	Werlatone	C8060-102	2141	N/A		

4.2. Measurement Uncertainty

Measurement uncertainty for 300 MHz to 3 GHz averaged over 1 gram					
Component	Error, %	Distribution	Divisor	Sensitivity	U (Xi), %
Measurement System					
Probe Calibration (k=1)	6.00	Normal	1	1	6.00
Axial Isotropy	1.15	Rectangular	1.732	0.7071	0.47
Hemispherical Isotropy	2.30	Rectangular	1.732	0.7071	0.94
Boundary Effect	0.90	Rectangular	1.732	1	0.52
Probe Linearity	3.45	Rectangular	1.732	1	1.99
System Detection Limits	1.00	Rectangular	1.732	1	0.58
Readout Electronics	0.30	Normal	1	1	0.30
Response Time	0.80	Rectangular	1.732	1	0.46
Integration Time	2.60	Rectangular	1.732	1	1.50
RF Ambient Conditions - Noise	3.00	Rectangular	1.732	1	1.73
RF Ambient Conditions - Reflections	3.00	Rectangular	1.732	1	1.73
Probe Positioner Mechanical Tolerance	0.40	Rectangular	1.732	1	0.23
Probe Positioning with respect to Phantom	2.90	Rectangular	1.732	1	1.67
Extrapolation, Interpolation and Integration	1.00	Rectangular	1.732	1	0.58
Test Sample Related					
Test Sample Positioning	2.90	Normal	1	1	2.90
Device Holder Uncertainty	3.60	Normal	1	1	3.60
Output Power Variation - SAR Drift	5.00	Rectangular	1.732	1	2.89
Phantom and Tissue Parameters					
Phantom Uncertainty (shape and thickness)	4.00	Rectangular	1.732	1	2.31
Liquid Conductivity - deviation from target	5.00	Rectangular	1.732	0.64	1.85
Liquid Conductivity - measurement	4.21	Normal	1	0.64	2.69
Liquid Permittivity - deviation from target	5.00	Rectangular	1.732	0.6	1.73
Liquid Permittivity - measurement uncertainty	-4.06	Normal	1	0.6	-2.44
Combined Standard Uncertainty Uc(y) =					10.40
Expanded Uncertainty U, Coverage Factor = 2, > 95 % Confidence =				20.79 %	
Expanded Uncertainty U, Coverage Factor = 2, > 95 % Confidence =				1.64 dB	

5. Measurement System Description and Setup

The DASY5 system used for performing compliance tests consists of the following items:

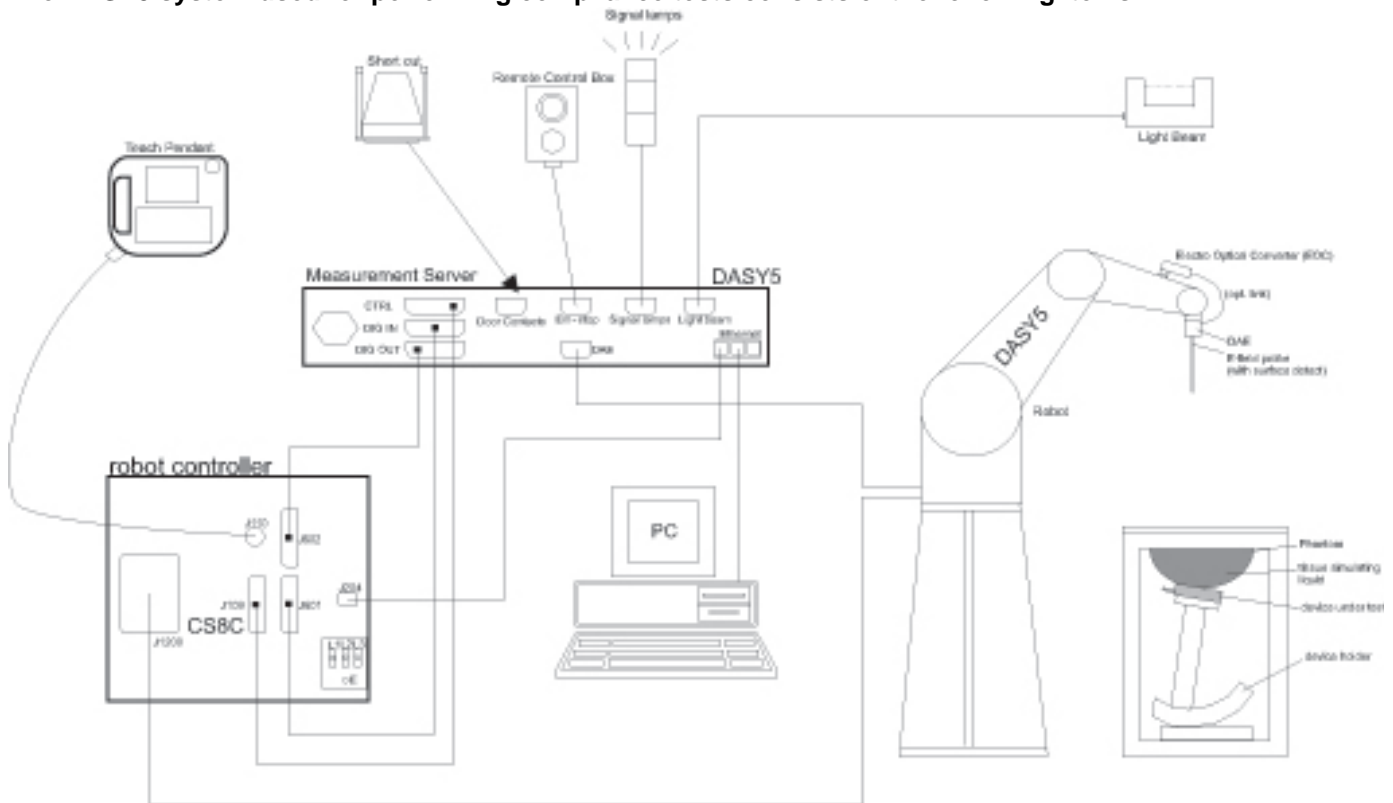

- A standard high precision 6-axis robot with controller, teach pendant and software. An arm extension for accommodating the data acquisition electronics (DAE).
- An isotropic Field probe optimized and calibrated for the targeted measurement.
- A data acquisition electronics (DAE) which performs the signal amplification, signal multiplexing, AD-conversion, offset measurements, mechanical surface detection, collision detection, etc. The unit is battery powered with standard or rechargeable batteries. The signal is optically transmitted to the EOC.
- The Electro-optical converter (EOC) performs the conversion from optical to electrical signals for the digital communication to the DAE. To use optical surface detection, a special version of the EOC is required. The EOC signal is transmitted to the measurement server.
- The function of the measurement server is to perform the time critical tasks such as signal filtering, control of the robot operation and fast movement interrupts.
- The Light Beam used is for probe alignment. This improves the (absolute) accuracy of the probe positioning.
- A computer running WinXP or Win7 and the DASY5 software.
- Remote control and teach pendant as well as additional circuitry for robot safety such as warning lamps, etc.
- The phantom, the device holder and other accessories according to the targeted measurement.

6. SAR Measurement Procedure

6.1. Normal SAR Measurement Procedure

Step 1: Power Reference Measurement

The Power Reference Measurement and Power Drift Measurements are for monitoring the power drift of the device under test in the batch process. The minimum distance of probe sensors to surface determines the closest measurement point to phantom surface. The minimum distance of probe sensors to surface is 2.1 mm. This distance cannot be smaller than the distance of sensor calibration points to probe tip as defined in the probe properties.

Step 2: Area Scan

The Area Scan is used as a fast scan in two dimensions to find the area of high field values, before doing a fine measurement around the hot spot. The sophisticated interpolation routines implemented in DASY software can find the maximum locations even in relatively coarse grids. When an Area Scan has measured all reachable points, it computes the field maximal found in the scanned area, within a range of the global maximum. The range (in dB) is specified in the standards for compliance testing. For example, a 2 dB range is required in IEEE Standard 1528 and IEC 62209 standards, whereby 3 dB is a requirement when compliance is assessed in accordance with the ARIB standard (Japan). If only one Zoom Scan follows the Area Scan, then only the absolute maximum will be taken as reference. For cases where multiple maximums are detected, the number of Zoom Scans has to be increased accordingly.

Step 3: Zoom Scan

Zoom Scans are used to assess the peak spatial SAR values within a cubic averaging volume containing 1 g and 10 g of simulated tissue. The Zoom Scan measures $\geq 7 \times 7 \times 9$ (above 4.5 GHz) or $5 \times 5 \times 7$ (below 3 GHz) points within a cube whose base faces are centered on the maxima found in a preceding area scan job within the same procedure. When the measurement is done, the Zoom Scan evaluates the averaged SAR for 1 g and 10 g and displays these values next to the job's label.

Step 4: Power drift measurement

The Power Drift Measurement measures the field at the same location as the most recent power reference measurement within the same procedure, and with the same settings. The Power Drift Measurement gives the field difference in dB from the reading conducted within the last Power Reference Measurement. This allows a user to monitor the power drift of the device under test within a batch process. The measurement procedure is the same as Step 1.

Step 5: Z-Scan (FCC only)

The Z Scan measures points along a vertical straight line. The line runs along the Z-axis of a one-dimensional grid. In order to get a reasonable extrapolation the extrapolated distance should not be larger than the step size in Z-direction.

6.2. Volume Scan Procedures

Step 1: Power Reference Measurement

The Power Reference Measurement and Power Drift Measurements are for monitoring the power drift of the device under test in the batch process. The minimum distance of probe sensors to surface determines the closest measurement point to phantom surface. The minimum distance of probe sensors to surface is 2.1 mm. This distance cannot be smaller than the distance of sensor calibration points to probe tip as defined in the probe properties.

Step 2: Area Scan

The Area Scan is used as a fast scan in two dimensions to find the area of high field values, before doing a fine measurement around the hot spot. The sophisticated interpolation routines implemented in DASY software can find the maximum locations even in relatively coarse grids. When an Area Scan has measured all reachable points, it computes the field maximal found in the scanned area, within a range of the global maximum. The range (in dB) is specified in the standards for compliance testing. For example, a 2 dB range is required in IEEE Standard 1528 and IEC 62209 standards, whereby 3 dB is a requirement when compliance is assessed in accordance with the ARIB standard (Japan). If only one Zoom Scan follows the Area Scan, then only the absolute maximum will be taken as reference. For cases where multiple maximums are detected, the number of Zoom Scans has to be increased accordingly.

Step 3: Zoom Scan

Zoom Scans are used to assess the peak spatial SAR values within a cubic averaging volume containing 1 g and 10 g of simulated tissue. The Zoom Scan measures $\geq 7 \times 7 \times 9$ (above 4.5 GHz) or $5 \times 5 \times 7$ (below 3 GHz) points within a cube whose base faces are centered on the maxima found in a preceding area scan job within the same procedure. When the measurement is done, the Zoom Scan evaluates the averaged SAR for 1 g and 10 g and displays these values next to the job's label.

Step 4: Volume Scan

Volume Scans are used to assess peak SAR and averaged SAR measurements in largely extended 3-dimensional volumes within any phantom. This measurement does not need any previous area scan. The grid can be anchored to a user specific point or to the current probe location.

Step 5: Power drift measurement

The Power Drift Measurement measures the field at the same location as the most recent power reference measurement within the same procedure, and with the same settings. The Power Drift Measurement gives the field difference in dB from the reading conducted within the last Power Reference Measurement. This allows a user to monitor the power drift of the device under test within a batch process. The measurement procedure is the same as Step 1.

7. Summary of Highest 1-g SAR

Worst Case SAR data for each Frequency Band

FCC Rule Parts	Freq. Range	Highest 1-g SAR	Limit
22	824-849 MHz	Head: 0.332 W/kg (Left Touch) (1xEV-DO) Body & Hotspot: 0.894 W/kg (Rear w/ 10mm distance) (1xRTT) w/ headset	1.6 W/kg
24	1850-1910 MHz	Head: 0.801 W/kg (Right Touch) (1xRTT) Body & Hotspot: 1.24 W/kg (Rear w/ 10mm distance) (1xRTT)	
27 (LTE Band 13)	777-787 MHz	Head: 0.134 W/kg (Left Touch) Body & Hotspot: 0.576 W/kg (Rear w/ 10 mm distance)	
15.247	2412-2462 MHz	Head: 0.151 W/kg (Right Touch) Body & Hotspot: 0.139 W/kg (Rear w/ 10 mm distance)	
Simultaneous transmission condition		1.526 W/kg (Sec. 15.2.2) (The highest SAR across exposure conditions)	

8. Device Under Test

Cellular/PCS CDMA/EVDO/GSM/GPRS/EDGE, PCS WCDMA/HSPA and AWS LTE Phone with Bluetooth, WLAN , & NFC Model: LG-VS950, VS950, LGVS950	
Normal operation	<ul style="list-style-type: none"> - Held to head, - Body (Rear and Front sides) with 10 mm separation distance. - Hotspot (wireless router) with 10 mm separation distance to all sides and edges.
Accessory	1. Headset

8.1. Band and Air Interfaces

Tx Frequency Bands	<ul style="list-style-type: none"> - GSM850: 824 - 849 MHz - GSM1900: 1850 - 1910 MHz - W-CDMA Band II: 1850 - 1910 MHz - CDMA BC 0: 824 - 849 MHz - CDMA BC 1: 1850 - 1910 MHz - LTE Band 13: 777 - 787 MHz - 802.11ab/g/n: 2412 - 2462 MHz, b / g / HT20 - Bluetooth: 2402 - 2480 MHz
GPRS Multi-Slot Class:	10
GPRS Class:	B
DTM Class:	Not supported

8.2. Hotspot (Wireless router) Exposure Condition

The device is capable of personal hotspot mode. The hotspot mode can be enabled by the user.

8.3. Simultaneous Transmission

*** Simultaneous Transmission Scenario**

No.	Capable TX Configuration	CDMA 1xRTT	CDMA EVDO	LTE	GSM Voice	GSM GPRS/EDGE	WCDMA	WiFi 2.4Ghz
1	CDMA 1xRTT		O	O	X	X	X	O
2	CDMA EVDO	O		X	X	X	X	O
3	LTE	O	X		X	X	X	O
4	GSM voice	X	X	X		X	X	O
5	GSM GPRS/EDGE	X	X	X	X		X	X
6	WCDMA	X	X	X	X	X		O
7	WiFi 2.4Ghz	O	O	O	O	X	O	
8	Bluetooth 2.4Ghz	SAR testing is not required						
9	NFC	SAR testing is not required						

*** Worst Case Simultaneous SAR Cases**

No.	Capable TX Configuration	Head SAR	Body SAR	Hotspot SAR	Power Reduction (EVDO)	Power Reduction (LTE)	Note
1	GSM 850 Voice + WiFi 2.4Ghz	O	X	X	X	X	GSM voice + WiFi
2	GSM 1900 Voice + WiFi 2.4Ghz	O	X	X	X	X	GSM voice + WiFi
3	GSM 850 GPRS/EDGE	X	O	X	X	X	GSM GPRS/EDGE
4	GSM 1900 GPRS/EDGE	X	O	X	X	X	GSM GPRS/EDGE
5	WCDMA 1900 + WiFi 2.4Ghz	O	O	O	X	X	WCDMA + WiFi
6	CDMA BC0 1xRTT + CDMA BC0 EvDO + WiFi 2.4Ghz	O	O	O	O	X	WiFi Hotspot + SVDO
7	CDMA BC0 1xRTT + CDMA BC1 EvDO + WiFi 2.4Ghz	O	O	O	O	X	WiFi Hotspot + SVDO
8	CDMA BC0 1xRTT + LTE B13 + WiFi 2.4Ghz	O	O	O	X	O	WiFi Hotspot + SVLTE
9	CDMA BC1 1xRTT + CDMA BC0 EvDO+ WiFi 2.4Ghz	O	O	O	O	X	WiFi Hotspot + SVDO
10	CDMA BC1 1xRTT + CDMA BC1 EvDO+ WiFi 2.4Ghz	O	O	O	O	X	WiFi Hotspot + SVDO
11	CDMA BC1 1xRTT + LTE B13+ WiFi 2.4Ghz	O	O	O	X	O	WiFi Hotspot + SVLTE

* Hotspot support : LTE, WCDMA, CDMA 1xRTT and EvDO [GPRS/EDGE is not supported Hotspot]
 * SVLTE, SVDO is supported
 * BT and NFC SAR testing is not required

O = Can Transmit Simultaneously
 X = Cannot Transmit Simultaneously

Notes:

1. WiFi 2.4 GHz and BT cannot transmit simultaneously

8.4. KDB 941225 D05 SAR for LTE Devices v01

#	Description	Information																																						
1	Identify the operating frequency range of each LTE transmission band used by the device	Band 13: 777 - 787 MHz																																						
2	Identify the channel bandwidths used in each frequency band; 1.4, 3, 5, 10, 15, 20 MHz etc	Band 13: 10 MHz																																						
3	Identify the high, middle and low (H, M, L) channel numbers and frequencies in each LTE frequency band	LTE Band13 - Bandwidth: 10MHz Ch No.: 23230 Frequency: 782MHz																																						
4	Specify the UE category and uplink modulations used	The UE Category is 3 Uplink modulations: QPSK, 16QAM																																						
5	Descriptions of the LTE transmitter and antenna implementation & identify whether it is a standalone transmitter operating independently of other wireless transmitters in the device or sharing hardware components and/or antenna(s) with other transmitters etc.	This model(VS950) has the same HW and one Tx antenna for CDMA US PCS (BC1) EVDO/LTE Band 13/W-CDMA Band II. For details, please refer to the Section of the antenna distance document.																																						
6	Identify the LTE voice/data requirements in each operating mode and exposure condition with respect to head and body test configurations, antenna locations, handset flip-cover or slide positions, antenna diversity conditions, etc.	Exposure conditions 1. Body SAR is required. 2. Hotspot SAR: Front, Rear, Edge 3 and Edge 4 require assessment for SAR evaluation. 3. Please refer to the Section of the antenna distance document for definition of edges and test positions, and the Section for the specific test positions required for LTE Band 13.																																						
7	Identify if Maximum Power Reduction (MPR) is optional or mandatory, i.e. built-in by design: a) only mandatory MPR may be considered during SAR testing, when the maximum output power is permanently limited by the MPR implemented within the UE; and only for the applicable RB (resource block) configurations specified in LTE standards b) A-MPR (additional MPR) must be disabled.	As per 3GPP TS 36.101: Table 6.2.3-1: Maximum Power Reduction (MPR) for Power Class 3 <table border="1" data-bbox="699 1142 1461 1304"> <thead> <tr> <th rowspan="2">Modulation</th> <th colspan="6">Channel bandwidth / Transmission bandwidth (RB)</th> <th rowspan="2">MPR (dB)</th> </tr> <tr> <th>1.4 MHz</th> <th>3.0 MHz</th> <th>5 MHz</th> <th>10 MHz</th> <th>15 MHz</th> <th>20 MHz</th> </tr> </thead> <tbody> <tr> <td>QPSK</td> <td>> 5</td> <td>> 4</td> <td>> 8</td> <td>> 12</td> <td>> 16</td> <td>> 18</td> <td>≤ 1</td> </tr> <tr> <td>16 QAM</td> <td>≤ 5</td> <td>≤ 4</td> <td>≤ 8</td> <td>≤ 12</td> <td>≤ 16</td> <td>≤ 18</td> <td>≤ 1</td> </tr> <tr> <td>16 QAM</td> <td>> 5</td> <td>> 4</td> <td>> 8</td> <td>> 12</td> <td>> 16</td> <td>> 18</td> <td>≤ 2</td> </tr> </tbody> </table> MPR is permanently built-in by design. A-MPR was disabled	Modulation	Channel bandwidth / Transmission bandwidth (RB)						MPR (dB)	1.4 MHz	3.0 MHz	5 MHz	10 MHz	15 MHz	20 MHz	QPSK	> 5	> 4	> 8	> 12	> 16	> 18	≤ 1	16 QAM	≤ 5	≤ 4	≤ 8	≤ 12	≤ 16	≤ 18	≤ 1	16 QAM	> 5	> 4	> 8	> 12	> 16	> 18	≤ 2
Modulation	Channel bandwidth / Transmission bandwidth (RB)						MPR (dB)																																	
	1.4 MHz	3.0 MHz	5 MHz	10 MHz	15 MHz	20 MHz																																		
QPSK	> 5	> 4	> 8	> 12	> 16	> 18	≤ 1																																	
16 QAM	≤ 5	≤ 4	≤ 8	≤ 12	≤ 16	≤ 18	≤ 1																																	
16 QAM	> 5	> 4	> 8	> 12	> 16	> 18	≤ 2																																	
8	Include the maximum average conducted output power measured on the required test channels for each channel bandwidth and UL modulation used in each frequency band: a) with 1 RB allocated at the upper edge of a channel b) with 1 RB allocated at the lower edge of a channel c) using 50% RB allocation centered within a channel d) using 100% RB allocation	Refer to the Section of the RF output power table																																						

KDB 941225 D05 SAR for LTE devices v01 (Continued)

#	Description	Information																
9	Identify all other U.S. wireless operating modes (3G, Wi-Fi, WiMax, Bluetooth etc), device/exposure configurations (head and body, antenna and handset flip-cover or slide positions, antenna diversity conditions etc.) and frequency bands used for these modes	* Supported band & Exposure conditions 1) Bluetooth 2.4GHz - Exposure Conditions: BT SAR is not required due to the lower power & antenna separation distance. 2) WiFi 2.4GHz - Exposure Conditions: Head/Body SAR required * WiFi hotspot is supported. 3) Supported WWAN bands: GSM850/1900, W-CDMA Band II, & CDMA BC0/BC1 -Exposure Conditions: Head and Body SAR required.																
10	Include the maximum average conducted output power measured for the other wireless mode and frequency bands	See the section of RF output power measurements																
11	Identify the simultaneous transmission conditions for the voice and data configurations supported by all wireless modes, device configurations and frequency bands, for the head and body exposure conditions and device operating configurations (handset flip or cover positions, antenna diversity conditions etc.)	Refer to the table in the section of Simultaneous Transmission																
12	When power reduction is applied to certain wireless modes to satisfy SAR compliance for simultaneous transmission conditions, other equipment certification or operating requirements, include the maximum average conducted output power measured in each power reduction mode applicable to the simultaneous voice/data transmission configurations for such wireless configurations and frequency bands; and also include details of the power reduction implementation and measurement setup	<p>1. Power Reduction operation table for SVDO Mode</p> <table border="1"> <thead> <tr> <th>Mode</th> <th>CDMA Current Voice Power for BC0 & BC1 (1xRTT target Power = BC0 24.3dBm) (1xRTT target Power = BC1 23.7dBm)</th> <th>CDMA EVDO Max. Power for BC0 & BC1 (EVDO target Power = 23.7dBm)</th> </tr> </thead> <tbody> <tr> <td rowspan="2">SVDO</td> <td>P < 15.5 dBm</td> <td>23.7dBm(Limited)</td> </tr> <tr> <td>P ≥ 15.5 dBm</td> <td>18.7dBm(Limited)</td> </tr> </tbody> </table> <p>2. Power Reduction operation table for SVLTE Mode</p> <table border="1"> <thead> <tr> <th>Mode</th> <th>CDMA Current Voice Power for BC0 & BC1 (1xRTT target Power = BC0 24.3dBm) (1xRTT target Power = BC1 23.7dBm)</th> <th>LTE Max. Power for BC13 (LTE target Power = 22.8dBm)</th> </tr> </thead> <tbody> <tr> <td rowspan="2">SVLTE</td> <td>P < 18.5 dBm</td> <td>22.8dBm(Limited)</td> </tr> <tr> <td>P ≥ 18.5 dBm</td> <td>18.8dBm(Limited)</td> </tr> </tbody> </table>	Mode	CDMA Current Voice Power for BC0 & BC1 (1xRTT target Power = BC0 24.3dBm) (1xRTT target Power = BC1 23.7dBm)	CDMA EVDO Max. Power for BC0 & BC1 (EVDO target Power = 23.7dBm)	SVDO	P < 15.5 dBm	23.7dBm(Limited)	P ≥ 15.5 dBm	18.7dBm(Limited)	Mode	CDMA Current Voice Power for BC0 & BC1 (1xRTT target Power = BC0 24.3dBm) (1xRTT target Power = BC1 23.7dBm)	LTE Max. Power for BC13 (LTE target Power = 22.8dBm)	SVLTE	P < 18.5 dBm	22.8dBm(Limited)	P ≥ 18.5 dBm	18.8dBm(Limited)
Mode	CDMA Current Voice Power for BC0 & BC1 (1xRTT target Power = BC0 24.3dBm) (1xRTT target Power = BC1 23.7dBm)	CDMA EVDO Max. Power for BC0 & BC1 (EVDO target Power = 23.7dBm)																
SVDO	P < 15.5 dBm	23.7dBm(Limited)																
	P ≥ 15.5 dBm	18.7dBm(Limited)																
Mode	CDMA Current Voice Power for BC0 & BC1 (1xRTT target Power = BC0 24.3dBm) (1xRTT target Power = BC1 23.7dBm)	LTE Max. Power for BC13 (LTE target Power = 22.8dBm)																
SVLTE	P < 18.5 dBm	22.8dBm(Limited)																
	P ≥ 18.5 dBm	18.8dBm(Limited)																
13	Include descriptions of the test equipment, test software, built-in test firmware etc. required to support testing the device when power reduction is applied to one or more transmitters/antennas for simultaneous voice/data transmission	Not Applicable																
14	When appropriate, include a SAR test plan proposal with respect to the above	Not Applicable																
15	If applicable, include preliminary SAR test data and/or supporting information in laboratory testing inquiries to address specific issues and concerns or for requesting further test reduction considerations appropriate for the device; for example, simultaneous transmission configurations	Not applicable																

9. Summary of Test Configurations

Refer to Section 18 “Antenna Location and Separation Distances” for the specific details of the antenna-to-antenna and antenna-to-edge(s) distances.

9.1. Head Exposure Condition for WWAN, LTE and WiFi

Test Configurations	SAR Required	Note
Left Touch	Yes	
Left Tilt (15°)	Yes	
Right Touch	Yes	
Right Tilt (15°)	Yes	

9.2. Body Exposure Conditions for GSM850/1900/W-CDMA Band II/CDMA (BC0/BC1) 1xRTT

Test Configurations	Antenna-to-edge/surface	SAR Required	Note
Rear	< 25 mm	Yes	
Front	< 25 mm	Yes	
Edge 1	117 mm	No	SAR is not required because the distance from the antenna to the edge is > 2.5 cm as per KDB 941225 D06 Hot Spot SAR v01
Edge 2	9 mm	Yes	
Edge 3	2 mm	Yes	
Edge 4	33 mm	No	SAR is not required because the distance from the antenna to the edge is > 2.5 cm as per KDB 941225 D06 Hot Spot SAR v01

9.3. Body Exposure Conditions for CDMA (BC0/BC1), 1xEVDO

Test Configurations	Antenna-to-edge/surface	SAR Required	Note
Rear	< 25 mm	Yes	
Front	< 25 mm	Yes	
Edge 1	3.5 mm	Yes	
Edge 2	1.8 mm	Yes	
Edge 3	90 mm	No	SAR is not required because the distance from the antenna to the edge is > 2.5 cm as per KDB 941225 D06 Hot Spot SAR v01
Edge 4	68.2 mm	No	Ditto

9.4. Body Exposure Conditions for LTE Band 13

Test Configurations	Antenna-to-edge/surface	SAR Required	Note
Rear	< 25 mm	Yes	
Front	< 25 mm	Yes	
Edge 1	124 mm	No	SAR is not required because the distance from the antenna to the edge is > 2.5 cm as per KDB 941225 D06 Hot Spot SAR v01
Edge 2	66 mm	No	Ditto
Edge 3	2 mm	Yes	
Edge 4	9 mm	Yes	

9.5. Body Exposure Conditions for WiFi

Test Configurations	Antenna-to-edge/surface	SAR Required	Note
Rear	< 25 mm	Yes	
Front	< 25 mm	Yes	
Edge 1	4.5 mm	Yes	
Edge 2	32.8 mm	No	SAR is not required because the distance from the antenna to the edge is > 2.5 cm as per KDB 941225 D06 Hot Spot SAR v01
Edge 3	119 mm	No	Ditto
Edge 4	34.7 mm	No	Ditto

10. RF Output Power Measurement

10.1. GSM850

Target Power: 32.3 dBm

Tune-up Tolerance: +0.7 dB

GSM (GMSK) Voice Mode

Band	Ch No.	Freq. (MHz)	Avg burst Pwr (dBm)			
850	128	824.2	32.8			
	190	836.6	32.6			
	251	848.8	32.5			
Band	Ch No.	f (MHz)	Avg burst Pwr (dBm)			
			1 slot	Frame Avg Pwr	2 slots	Frame Avg Pwr
850	128	824.2	32.8	23.8	31.5	25.5
	190	836.6	32.6	23.6	31.3	25.3
	251	848.8	32.5	23.5	31.3	25.3

EGPRS (8PSK) - Coding Scheme: MCS5

Band	Ch No.	f (MHz)	Avg burst Pwr (dBm)			
850	128	824.2	26.9	17.9	25.4	19.4
	190	836.6	26.8	17.8	25.3	19.3
	251	848.8	26.9	17.9	25.4	19.4

Notes:

The worst-case configuration and mode for SAR testing is determined to be as follows:

- Head: GMSK Voice Mode
- Body: GMSK (GPRS) mode with 2 time slots, based on the output power measurements above
- SAR is not required for EGPRS (8PSK) Mode because its output power is less than that of GPRS Mode

10.2. GSM1900

Target Power: 29.0 dBm
 Tune-up Tolerance: +0.7 dB

GSM (GMSK) Voice Mode

Band	Ch No.	Freq. (MHz)	Avg burst Pwr (dBm)
1900	512	1850.2	29.2
	661	1880.0	29.3
	810	1909.8	29.2

GPRS (GMSK) - Coding Scheme: CS1

Band	Ch No.	f (MHz)	Avg burst Pwr (dBm)			
			1 slot	Frame Avg Pwr	2 slots	Frame Avg Pwr
1900	512	1850.2	29.3	20.3	28.5	22.5
	661	1880.0	29.4	20.4	28.5	22.5
	810	1909.8	29.3	20.3	28.5	22.5

EGPRS (8PSK) - Coding Scheme: MCS5

Band	Ch No.	f (MHz)	Avg burst Pwr (dBm)			
			1 slot	Frame Avg Pwr	2 slots	Frame Avg Pwr
1900	512	1850.2	25.7	16.7	24.4	18.4
	661	1880.0	26.0	17.0	24.5	18.5
	810	1909.8	25.9	16.9	24.5	18.5

Notes:

The worst-case configuration and mode for SAR testing is determined to be as follows:

- Head: GMSK Voice Mode
- Body: GMSK (GPRS) mode with 2 time slots, based on the output power measurements above
- SAR is not required for EGPRS (8PSK) Mode because its output power is less than that of GPRS Mode

10.3. W-CDMA Band II

Target Power: 22.5 dBm
 Tune-up Tolerance: +0.7 dB

Release 99

The following tests were completed according to the test requirements outlined in section 5.2 of the 3GPP TS34.121-1 specification. The DUT supports power Class 3, which has a nominal maximum output power of 24 dBm (+1.7/-3.7).

Mode	Subtest	Rel99
WCDMA General Settings	Loopback Mode	Test Mode 1
	Rel99 RMC	12.2kbps RMC
	Power Control Algorithm	Algorithm2
	β_c/β_d	8/15

Results

Band	Mode	UL Ch No.	Freq. (MHz)	Avg Pwr (dBm)
W-CDMA (UMTS) Band II	Rel 99 (RMC, 12.2 kbps)	9262	1852.4	22.8
		9400	1880.0	23.0
		9538	1907.6	22.8

HSDPA

The following 4 Sub-tests were completed according to Release 6 procedures in section 5.2 of 3GPP TS34.121. A summary of these settings are illustrated below:

Mode	HSDPA	HSDPA	HSDPA	HSDPA
Subtest	1	2	3	4
W-CDMA General Settings	Loopback Mode			
	Test Mode 1			
	Rel99 RMC			
	12.2kbps RMC			
	HSDPA FRC			
	H-Set1			
	Power Control Algorithm			
	Algorithm 2			
	β_c	2/15	12/15	15/15
β_d	15/15	15/15	8/15	4/15
Bd (SF)				
64				
β_c/β_d	2/15	12/15	15/8	15/4
β_{hs}	4/15	24/15	30/15	30/15
CM (dB)	0	1	1.5	1.5
HSDPA Specific Settings	D_{ACK}			
	8			
	D_{NAK}			
	8			
	DCQI			
	8			
	Ack-Nack repetition factor			
3				
CQI Feedback (Table 5.2B.4)				
4ms				
CQI Repetition Factor (Table 5.2B.4)				
2				
$A_{hs} = \beta_{hs}/\beta_c$				
30/15				

Results

Mode	UL Ch No.	Freq. (MHz)	Target MPR	Meas. MPR	Avg Pwr (dBm)
Subtest 1	9262	1852.4	0	0	22.9
	9400	1880.0	0	0	22.9
	9538	1907.6	0	0	22.8
Subtest 2	9262	1852.4	0	0	22.9
	9400	1880.0	0	0	23.0
	9538	1907.6	0	0	22.8
Subtest 3	9262	1852.4	0.5	0.5	22.3
	9400	1880.0	0.5	0.5	22.5
	9538	1907.6	0.5	0.4	22.3
Subtest 4	9262	1852.4	0.5	0.5	22.4
	9400	1880.0	0.5	0.6	22.4
	9538	1907.6	0.5	0.4	22.3

Note(s):

- KDB 941225 D01 – Body SAR is not required for HSDPA when the maximum average output of each RF channel with HSDPA active is less than ¼ dB higher than that measured without HSDPA using 12.2 kbps RMC or the maximum SAR for 12.2 kbps RMC is < 75% of the SAR limit.
- *: Please refer to the separately attached document *MPR HSUPA Issue_ZNFVS950* for a detailed explanation/justification from the manufacturer on why MPR was not implemented for this particular mode on this device.

HSPA (HSDPA & HSUPA)

The following 5 Sub-tests were completed according to Release 6 procedures in section 5.2 of 3GPP TS34.121. A summary of these settings are illustrated below:

Mode	HSPA	HSPA	HSPA	HSPA	HSPA	
Subtest	1	2	3	4	5	
WCDMA General Settings	Loopback Mode					
	Test Mode 1					
	Rel99 RMC					
	12.2kbps RMC					
	HSDPA FRC					
	H-Set1					
	HSUPA Test					
	HSUPA Loopback					
	Power Control Algorithm					
	Algorithm2					
	β_c	11/15	6/15	15/15	2/15	15/15
	β_d	15/15	15/15	9/15	15/15	15/15
β_{ec}	209/225	12/15	30/15	2/15	24/15	
β_c/β_d	11/15	6/15	15/9	2/15	15/15	
β_{hs}	22/15	12/15	30/15	4/15	30/15	
β_{ed}	1309/225	94/75	47/15	56/75	134/15	
CM (dB)	1.0	3.0	2.0	3.0	1.0	
MPR (dB)	0	2	1	2	0	
HSDPA Specific Settings	DACK					
	8					
	DNAK					
	8					
	DCQI					
	8					
Ack-Nack repetition factor						
3						
CQI Feedback (Table 5.2B.4)						
4ms						
CQI Repetition Factor (Table 5.2B.4)						
2						
$A_{hs} = \beta_{hs}/\beta_c$						
30/15						
HSUPA Specific Settings	D E-DPCCH	6	8	8	5	7
	DHARQ	0	0	0	0	0
	AG Index	20	12	15	17	21
	ETFCI (from 34.121 Table C.11.1.3)	75	67	92	71	81
	Associated Max UL Data Rate kbps	242.1	174.9	482.8	205.8	308.9
	Reference E_TFCIs	E-TFCI 11 E-TFCI PO 4 E-TFCI 67 E-TFCI PO 18 E-TFCI 71 E-TFCI PO 23 E-TFCI 75 E-TFCI PO 26 E-TFCI 81 E-TFCI PO 27		E-TFCI 11 E-TFCI PO 4 E-TFCI 92 E-TFCI PO 18		E-TFCI 11 E-TFCI PO 4 E-TFCI 67 E-TFCI PO 18 E-TFCI 71 E-TFCI PO 23 E-TFCI 75 E-TFCI PO 26 E-TFCI 81 E-TFCI PO 27

Results

Mode	UL Ch No.	Freq. (MHz)	Target MPR	*Meas. MPR	Avg Pwr (dBm)
Subtest 1	9262	1852.4	0	-0.1	22.9
	9400	1880.0	0	0.0	23.0
	9538	1907.6	0	-0.1	22.9
Subtest 2	9262	1852.4	2	-0.1	22.9
	9400	1880.0	2	0.0	23.0
	9538	1907.6	2	-0.1	22.9
Subtest 3	9262	1852.4	1	0.3	22.5
	9400	1880.0	1	0.5	22.5
	9538	1907.6	1	0.3	22.5
Subtest 4	9262	1852.4	2	-0.1	22.9
	9400	1880.0	2	0.0	22.9
	9538	1907.6	2	-0.1	22.9
Subtest 5	9262	1852.4	0	0.3	22.6
	9400	1880.0	0	0.4	22.6
	9538	1907.6	0	0.3	22.4

Note(s):

- KDB 941225 D01 – Body SAR is not required for handsets with HSPA capabilities when the maximum average output of each RF channel with HSUPA/HSDPA active is less than ¼ dB higher than that measured without HSUPA/HSDPA using 12.2 kbps RMC and the maximum SAR for 12.2kbps RMC is ≤ 75% of the SAR limit.
- *: Please refer to the separately attached document *MPR HSUPA Issue_ZNFVS950* for a detailed explanation/justification from the manufacturer on why MPR was not implemented for this particular mode on this device.

10.4. CDMA BC0

1xRTT

Target Power: 24.3 dBm

Tune-up Tolerance: +0.7 dB

CDMA			Avg Pwr (dBm)		
			RC1 - SO55	RC3 - SO55	RC3 - SO32
Band	Ch	Freq. (MHz)	(Loopback)	(Loopback)	(+F-SCH)
BC 0	1013	824.7	25.0	24.9	24.9
	384	836.52	25.0	24.9	25.0
	777	848.31	24.9	24.9	25.0

1xEv-Do Rel. 0

Target Power: 23.7 dBm

Tune-up Tolerance: +0.7 dB

Band	FTAP Rate	RTAP Rate	Channel	f (MHz)	Avg Pwr (dBm)
BC0	307.2 kbps (2 slot, QPSK)	153.6 kbps	1013	824.7	24.3
			384	836.52	24.4
			777	848.31	24.2

1xEv-Do Rev. A

Target Power: 23.7 dBm

Tune-up Tolerance: +0.7 dB

Band	FETAP Traffic Format	RETAP Data Payload Size	Channel	f (MHz)	Avg Pwr (dBm)
BC0	307.2k, QPSK/ ACK channel is transmitted at all the slots	4096	1013	824.7	24.0
			384	836.52	24.4
			777	848.31	24.2

10.5. CDMA BC1

1xRTT

Target Power: 23.7 dBm

Tune-up Tolerance: +0.7 dB

CDMA			Avg Pwr (dBm)		
			RC1 - SO55	RC3 - SO55	RC3 - SO32
Band	Ch	Freq. (MHz)	(Loopback)	(Loopback)	(+F-SCH)
BC 1	25	1851.25	24.3	24.3	24.2
	600	1880	24.3	24.2	24.2
	1175	1908.75	24.4	24.3	24.3

1xEv-Do Rel. 0

Target Power: 23.7 dBm

Tune-up Tolerance: +0.7 dB

Band	FTAP Rate	RTAP Rate	Channel	f (MHz)	Avg Pwr (dBm)
BC1	307.2 kbps (2 slot, QPSK)	153.6 kbps	25	1851.25	24.2
			600	1880	24.3
			1175	1908.75	24.2

1xEv-Do Rev. A

Target Power: 23.7 dBm

Tune-up Tolerance: +0.7 dB

Band	FETAP Traffic Format	RETAP Data Payload Size	Channel	f (MHz)	Avg Pwr (dBm)
BC1	307.2k, QPSK/ ACK channel is transmitted at all the slots	4096	25	1851.25	24.4
			600	1880	24.3
			1175	1908.75	24.2

10.6. LTE Band 13

Target Power: 22.8 dBm
 Tune-up Tolerance: +0.7 dB

The following tests were conducted according to the test requirements outlined in section 6.2 of the 3GPP TS36.101 specification.

UE Power Class: 3 (23 +/- 2dBm). The allowed Maximum Power Reduction (MPR) for the maximum output power due to higher order modulation and transmit bandwidth configuration (resource blocks) is specified in Table 6.2.3-1 of the 3GPP TS36.101.

Table 6.2.3-1: Maximum Power Reduction (MPR) for Power Class 3

Modulation	Channel bandwidth / Transmission bandwidth (RB)						MPR (dB)
	1.4 MHz	3.0 MHz	5 MHz	10 MHz	15 MHz	20 MHz	
QPSK	> 5	> 4	> 8	> 12	> 16	> 18	≤ 1
16 QAM	≤ 5	≤ 4	≤ 8	≤ 12	≤ 16	≤ 18	≤ 1
16 QAM	> 5	> 4	> 8	> 12	> 16	> 18	≤ 2

The allowed A-MPR values specified below in Table 6.2.4.-1 of 3GPP TS36.101 are in addition to the allowed MPR requirements. All the measurements below were performed with A-MPR disabled, by using Network Signaling Value of "NS_01".

Table 6.2.4-1: Additional Maximum Power Reduction (A-MPR)

Network Signalling value	Requirements (sub-clause)	E-UTRA Band	Channel bandwidth (MHz)	Resources Blocks (N_{RB})	A-MPR (dB)
NS_01	6.6.2.1.1	Table 5.5-1	1.4, 3, 5, 10, 15, 20	Table 5.6-1	NA
NS_03	6.6.2.2.1	2, 4, 10, 23, 25, 35, 36	3	>5	≤ 1
			5	>6	≤ 1
			10	>6	≤ 1
			15	>8	≤ 1
			20	>10	≤ 1
NS_04	6.6.2.2.2	41	5	>6	≤ 1
			10, 15, 20	See Table 6.2.4-4	
NS_05	6.6.3.3.1	1	10,15,20	≥ 50	≤ 1
NS_06	6.6.2.2.3	12, 13, 14, 17	1.4, 3, 5, 10	Table 5.6-1	n/a
NS_07	6.6.2.2.3	13	10	Table 6.2.4-2	Table 6.2.4-2
	6.6.3.3.2				
NS_08	6.6.3.3.3	19	10, 15	> 44	≤ 3
NS_09	6.6.3.3.4	21	10, 15	> 40	≤ 1
				> 55	≤ 2
NS_10		20	15, 20	Table 6.2.4-3	Table 6.2.4-3
NS_11	6.6.2.2.1	23 ¹	1.4, 3, 5, 10	Table 6.2.4-5	Table 6.2.4-5
..					
NS_32	-	-	-	-	-

Note 1: Applies to the lower block of Band 23, i.e. a carrier placed in the 2000-2010 MHz region.

Band 13

BW	Ch	Freq. (MHz)	Mode	UL RB Allocation	UL RB Start	Target MPR	Meas. MPR	Avg Pwr (dBm)
10	23230	782.0	QPSK	25	12	1	1	22.5
				1	0	0	0	23.5
				1	49	0	0	23.4
				50	0	1	1	22.3
			16QAM	25	12	2	2	21.4
				1	0	1	1	22.4
				1	49	1	1	22.4
				50	0	2	2	21.4

Note(s):

* When the power reduction due to proximity sensor is activated, the maximum conducted power is reduced, but the MPR for different resource block configurations/allocations is disabled.

10.7. Power Reduction for SV-DO

CDMA 1xRTT (BC0) to 1xEVDO (BC0 & BC1)

R & S CMU200 #1		R&S CMU 200					
CDMA BC0 1xRTT		BC0 1xEVDO			BC1 1xEVDO		
		Output Power [dBm]			Output Power [dBm]		
Ch. #	Output Power [dBm]	1013	384	777	25	600	1175
1013	15	24.4	24.3	24.4	24.3	24.3	24.3
	16	19.4	19.3	19.4	19.3	19.3	19.4
384	15	24.4	24.2	24.4	24.4	24.4	24.4
	16	19.4	19.3	19.4	19.3	19.4	19.3
777	15	24.4	24.2	24.3	24.4	24.3	24.4
	16	19.2	19.3	19.2	19.3	19.3	19.3

CDMA 1xRTT (BC1) to 1xEVDO (BC0 & BC1)

R & S CMU200 #1		R&S CMU 200					
CDMA BC1 1xRTT		BC0 1xEVDO			BC1 1xEVDO		
		Output Power [dBm]			Output Power [dBm]		
Ch. #	Output Power [dBm]	1013.0	384.0	777.0	25.0	600.0	1175.0
25	15	24.3	24.3	24.3	24.3	24.3	24.4
	16	19.2	19.4	19.3	19.1	19.4	19.3
600	15	24.4	24.4	24.3	24.4	24.3	24.4
	16	19.4	19.4	19.3	19.3	19.3	19.4
1175	15	24.4	24.2	24.2	24.4	24.4	24.4
	16	19.2	19.3	19.4	19.4	19.3	19.3

10.8. Power Reduction for SV-LTE Band 13

CDMA 1xRTT (BC0) to SV-LTE Band 13 (QPSK, 16QAM)

Agilent 8960		R&S CMW 500							
CDMA BC0 1xRTT		QPSK				16QAM			
		Output Power [dBm]				Output Power [dBm]			
Ch. #	Output Power [dBm]	1RB, 0 offset	1RB 49 offset	25RB 12 offset	50RB	1RB, 0 offset	1RB 49 offset	25RB 12 offset	50RB
1013	18	23.5	23.5	22.5	22.5	22.5	22.4	21.3	21.4
	19	19.5	19.5	19.5	19.4	19.5	19.3	19.4	19.5
384	18	23.5	23.2	22.4	22.3	22.5	22.1	21.2	21.3
	19	19.5	19.4	19.3	19.4	19.2	19.3	19.5	19.5
777	18	23.5	23.0	22.3	22.4	22.5	22.2	21.3	21.2
	19	19.5	19.5	19.3	19.4	19.5	19.5	19.3	19.5

CDMA 1xRTT (BC1) to SV-LTE Band 13 (QPSK, 16QAM)

Agilent 8960		R&S CMW 500							
CDMA BC1 1xRTT		QPSK				16QAM			
		Output Power [dBm]				Output Power [dBm]			
Ch. #	Output Power [dBm]	1RB, 0 offset	1RB 49 offset	25RB 12 offset	50RB	1RB, 0 offset	1RB 49 offset	25RB 12 offset	50RB
25	18	23.5	23.0	22.4	22.4	22.5	22.5	21.3	21.4
	19	19.3	19.5	19.5	19.4	19.4	19.5	19.5	19.5
600	18	23.5	23.0	22.4	22.4	22.5	22.4	21.4	21.4
	19	19.5	19.5	19.5	19.4	19.5	19.5	19.4	19.5
1175	18	23.5	23.0	22.4	22.5	22.5	22.4	21.4	21.4
	19	19.5	19.5	19.4	19.5	19.5	19.4	19.4	19.5

10.9. Wi-Fi (2.4 GHz)

Required Test Channels per KDB 248227 D01

Mode	Band	GHz	Channel	"Default Test Channels"	
				802.11b	802.11g
802.11b/g	2.4 GHz	2.412	1 [#]	√	∇
		2.437	6	√	∇
		2.462	11 [#]	√	∇

Notes:

√ = "default test channels"

∇ = possible 802.11g channels with maximum average output ¼ dB ≥ the "default test channels"

= when output power is reduced for channel 1 and /or 11 to meet restricted band requirements the highest output channels closest to each of these channels should be tested.

Output power table

Band (MHz)	Mode	Ch #	Freq. (MHz)	Measured Avg Pwr(dBm)
2.4	802.11b	1	2412	12.4
		6	2437	12.7
		11	2462	12.8
	802.11g	1	2412	12.3
		6	2437	12.5
		11	2462	12.7
	802.11n (HT20)	1	2412	11.1
		6	2437	11.5
		11	2462	11.2

Note(s):

- SAR is not required for 802.11g/HT20 channels when the maximum average output power is less than 1/4 dB higher than that measured on the corresponding 802.11a/b channels. As per KDB 248227

10.10. Bluetooth

Mode	Channel #	Freq. (MHz)	Conducted Avg Power	
			(dBm)	(mW)
GFSK	0	2402	10.3	10.72
	39	2441	10.1	10.23
	78	2480	9.2	8.32
8PSK	0	2402	8.0	6.31
	39	2441	7.9	6.17
	78	2480	6.9	4.90

Note(s):

According to KDB 648474, Table 2, Unlicensed transmitters

When there is simultaneous transmission, Stand-alone SAR not required due to

- Output ≤ 2 · P_{Ref} (13.8dBm / 24 mW) and antenna is ≥ 5.0 cm from other antennas
- Output ≤ P_{Ref} (10.79dBm / 12 mW) and antenna is ≥ 2.5 cm from other antennas
- Output ≤ P_{Ref} (10.79dBm / 12 mW) and antenna is < 2.5 cm from other antennas

11. Tissue Dielectric Properties

IEEE Std 1528-2003 Table 2

Target Frequency (MHz)	Head	
	ϵ_r	σ (S/m)
300	45.3	0.87
450	43.5	0.87
835	41.5	0.90
900	41.5	0.97
1450	40.5	1.20
1800 – 2000	40.0	1.40
2450	39.2	1.80
2600	39.0	1.96
3000	38.5	2.40

FCC OET Bulletin 65 Supplement C 01-01

Target Frequency (MHz)	Head		Body	
	ϵ_r	σ (S/m)	ϵ_r	σ (S/m)
150	52.3	0.76	61.9	0.80
300	45.3	0.87	58.2	0.92
450	43.5	0.87	56.7	0.94
835	41.5	0.90	55.2	0.97
900	41.5	0.97	55.0	1.05
915	41.5	0.98	55.0	1.06
1450	40.5	1.20	54.0	1.30
1610	40.3	1.29	53.8	1.40
1800 – 2000	40.0	1.40	53.3	1.52
2450	39.2	1.80	52.7	1.95
3000	38.5	2.40	52.0	2.73
5000	36.2	4.45	49.3	5.07
5100	36.1	4.55	49.1	5.18
5200	36.0	4.66	49.0	5.30
5300	35.9	4.76	48.9	5.42
5400	35.8	4.86	48.7	5.53
5500	35.6	4.96	48.6	5.65
5600	35.5	5.07	48.5	5.77
5700	35.4	5.17	48.3	5.88
5800	35.3	5.27	48.2	6.00

11.1. Composition of Ingredients for the Tissue Material Used in the SAR Tests

The following tissue formulations are provided for reference only as some of the parameters have not been thoroughly verified. The composition of ingredients may be modified accordingly to achieve the desired target tissue parameters required for routine SAR evaluation.

Ingredients (% by weight)	Frequency (MHz)									
	450		835		915		1900		2450	
Tissue Type	Head	Body	Head	Body	Head	Body	Head	Body	Head	Body
Water	38.56	51.16	41.45	52.4	41.05	56.0	54.9	40.4	62.7	73.2
Salt (NaCl)	3.95	1.49	1.45	1.4	1.35	0.76	0.18	0.5	0.5	0.04
Sugar	56.32	46.78	56.0	45.0	56.5	41.76	0.0	58.0	0.0	0.0
HEC	0.98	0.52	1.0	1.0	1.0	1.21	0.0	1.0	0.0	0.0
Bactericide	0.19	0.05	0.1	0.1	0.1	0.27	0.0	0.1	0.0	0.0
Triton X-100	0.0	0.0	0.0	0.0	0.0	0.0	0.0	0.0	36.8	0.0
DGBE	0.0	0.0	0.0	0.0	0.0	0.0	44.92	0.0	0.0	26.7
Dielectric Constant	43.42	58.0	42.54	56.1	42.0	56.8	39.9	54.0	39.8	52.5
Conductivity (S/m)	0.85	0.83	0.91	0.95	1.0	1.07	1.42	1.45	1.88	1.78

Salt: 99+% Pure Sodium Chloride Sugar: 98+% Pure Sucrose
 Water: De-ionized, 16 MΩ+ resistivity HEC: Hydroxyethyl Cellulose
 DGBE: 99+% Di(ethylene glycol) butyl ether, [2-(2-butoxyethoxy)ethanol]
 Triton X-100 (ultra pure): Polyethylene glycol mono [4-(1,1, 3, 3-tetramethylbutyl)phenyl]ether

MSL/HSL750 (Body and Head liquids for 700 – 800 MHz)

Item	Head Tissue Simulation Liquids HSL750 Muscle (body) Tissue Simulation Liquids MSL750
Type No	SL AAH 075
Manufacturer	SPEAG
The item is composed of the following ingredients:	
H ² O	Water, 35 – 58%
Sucrose	Sugar, white, refined, 40-60%
NaCl	Sodium Chloride, 0-6%
Hydroxyethyl-cellulose	Medium Viscosity (CAS# 9004-62-0), <0.3%
Preventol-D7	Preservative: aqueous preparation, (CAS# 55965-84-9), containing 5-chloro-2-methyl-3(2H)-isothiazolone and 2-methyl-3(2H)-isothiazolone, 0.1-0.7%

11.2. Tissue Dielectric Parameter Check Results

Tissue dielectric parameters were measured at the low, middle and high frequency of each operating frequency range of the test device.

Date	Freq. (MHz)	Liquid Parameters		Measured	Target	Delta (%)	Limit ±(%)	
4/26/2012	Body 1900	e'	52.9222	Relative Permittivity (ϵ_r):	52.92	53.30	-0.71	5
		e"	14.3584	Conductivity (σ):	1.52	1.52	-0.20	5
	Body 1850	e'	53.1097	Relative Permittivity (ϵ_r):	53.11	53.30	-0.36	5
		e"	14.2090	Conductivity (σ):	1.46	1.52	-3.84	5
	Body 1880	e'	53.0110	Relative Permittivity (ϵ_r):	53.01	53.30	-0.54	5
		e"	14.3083	Conductivity (σ):	1.50	1.52	-1.60	5
Body 1910	e'	52.8729	Relative Permittivity (ϵ_r):	52.87	53.30	-0.80	5	
	e"	14.3809	Conductivity (σ):	1.53	1.52	0.48	5	
4/27/2012	Head 1900	e'	41.1846	Relative Permittivity (ϵ_r):	41.18	40.00	2.96	5
		e"	13.6664	Conductivity (σ):	1.44	1.40	3.13	5
	Head 1850	e'	41.3621	Relative Permittivity (ϵ_r):	41.36	40.00	3.41	5
		e"	13.5277	Conductivity (σ):	1.39	1.40	-0.60	5
	Head 1880	e'	41.2795	Relative Permittivity (ϵ_r):	41.28	40.00	3.20	5
		e"	13.6214	Conductivity (σ):	1.42	1.40	1.71	5
Head 1910	e'	41.1313	Relative Permittivity (ϵ_r):	41.13	40.00	2.83	5	
	e"	13.6910	Conductivity (σ):	1.45	1.40	3.86	5	
4/28/2012	Head 835	e'	42.6812	Relative Permittivity (ϵ_r):	42.68	41.50	2.85	5
		e"	19.3911	Conductivity (σ):	0.90	0.90	0.03	5
	Head 820	e'	42.8676	Relative Permittivity (ϵ_r):	42.87	41.60	3.04	5
		e"	19.4328	Conductivity (σ):	0.89	0.90	-1.38	5
	Head 850	e'	42.4973	Relative Permittivity (ϵ_r):	42.50	41.50	2.40	5
		e"	19.3490	Conductivity (σ):	0.91	0.92	-0.06	5
4/30/2012	Body 835	e'	53.8289	Relative Permittivity (ϵ_r):	53.83	55.20	-2.48	5
		e"	21.7710	Conductivity (σ):	1.01	0.97	4.21	5
	Body 820	e'	53.9684	Relative Permittivity (ϵ_r):	53.97	55.28	-2.37	5
		e"	21.8134	Conductivity (σ):	0.99	0.97	2.70	5
	Body 850	e'	53.6790	Relative Permittivity (ϵ_r):	53.68	55.16	-2.68	5
		e"	21.7090	Conductivity (σ):	1.03	0.99	3.94	5
5/1/2012	Head 2450	e'	39.2411	Relative Permittivity (ϵ_r):	39.24	39.20	0.10	5
		e"	13.0731	Conductivity (σ):	1.78	1.80	-1.06	5
	Head 2410	e'	39.3582	Relative Permittivity (ϵ_r):	39.36	39.28	0.20	5
		e"	12.9344	Conductivity (σ):	1.73	1.76	-1.54	5
	Head 2435	e'	39.2908	Relative Permittivity (ϵ_r):	39.29	39.24	0.14	5
		e"	13.0207	Conductivity (σ):	1.76	1.78	-1.09	5
Head 2475	e'	39.1391	Relative Permittivity (ϵ_r):	39.14	39.17	-0.07	5	
	e"	13.1551	Conductivity (σ):	1.81	1.83	-0.91	5	
5/1/2012	Body 2450	e'	50.6224	Relative Permittivity (ϵ_r):	50.62	52.70	-3.94	5
		e"	14.4705	Conductivity (σ):	1.97	1.95	1.09	5
	Body 2410	e'	50.7653	Relative Permittivity (ϵ_r):	50.77	52.76	-3.78	5
		e"	14.2937	Conductivity (σ):	1.92	1.91	0.42	5
	Body 2435	e'	50.6772	Relative Permittivity (ϵ_r):	50.68	52.73	-3.89	5
		e"	14.4037	Conductivity (σ):	1.95	1.93	0.99	5
Body 2475	e'	50.5320	Relative Permittivity (ϵ_r):	50.53	52.67	-4.06	5	
	e"	14.5761	Conductivity (σ):	2.01	1.99	1.05	5	

Tissue Dielectric Parameter Check Results (continued)

Date	Freq. (MHz)	Liquid Parameters		Measured	Target	Delta (%)	Limit ±(%)	
5/1/2012	Body 750	e'	56.4153	Relative Permittivity (ϵ_r):	56.42	55.55	1.56	5
		e"	23.1069	Conductivity (σ):	0.96	0.96	0.06	5
	Body 775	e'	56.2134	Relative Permittivity (ϵ_r):	56.21	55.45	1.38	5
		e"	22.8782	Conductivity (σ):	0.99	0.97	2.16	5
	Body 790	e'	56.1071	Relative Permittivity (ϵ_r):	56.11	55.39	1.29	5
		e"	22.7611	Conductivity (σ):	1.00	0.97	3.48	5
5/2/2012	Head 750	e'	41.6482	Relative Permittivity (ϵ_r):	41.65	41.96	-0.75	5
		e"	21.3390	Conductivity (σ):	0.89	0.89	-0.36	5
	Head 780	e'	41.3110	Relative Permittivity (ϵ_r):	41.31	41.81	-1.19	5
		e"	21.1304	Conductivity (σ):	0.92	0.90	2.35	5
	Head 790	e'	41.2195	Relative Permittivity (ϵ_r):	41.22	41.76	-1.29	5
		e"	21.0726	Conductivity (σ):	0.93	0.90	3.29	5
5/3/2012	Body 750	e'	56.2792	Relative Permittivity (ϵ_r):	56.28	55.55	1.32	5
		e"	23.1560	Conductivity (σ):	0.97	0.96	0.27	5
	Body 775	e'	56.0448	Relative Permittivity (ϵ_r):	56.04	55.45	1.07	5
		e"	22.9231	Conductivity (σ):	0.99	0.97	2.36	5
	Body 790	e'	55.9288	Relative Permittivity (ϵ_r):	55.93	55.39	0.97	5
		e"	22.8016	Conductivity (σ):	1.00	0.97	3.67	5
5/3/2012	Body 835	e'	53.9865	Relative Permittivity (ϵ_r):	53.99	55.20	-2.20	5
		e"	21.2104	Conductivity (σ):	0.98	0.97	1.52	5
	Body 820	e'	54.1384	Relative Permittivity (ϵ_r):	54.14	55.28	-2.06	5
		e"	21.2580	Conductivity (σ):	0.97	0.97	0.08	5
	Body 850	e'	53.8396	Relative Permittivity (ϵ_r):	53.84	55.16	-2.39	5
		e"	21.1475	Conductivity (σ):	1.00	0.99	1.25	5
5/4/2012	Body 2450	e'	52.8854	Relative Permittivity (ϵ_r):	52.89	52.70	0.35	5
		e"	14.6493	Conductivity (σ):	2.00	1.95	2.34	5
	Body 2410	e'	53.0303	Relative Permittivity (ϵ_r):	53.03	52.76	0.51	5
		e"	14.5043	Conductivity (σ):	1.94	1.91	1.90	5
	Body 2435	e'	52.9385	Relative Permittivity (ϵ_r):	52.94	52.73	0.40	5
		e"	14.5918	Conductivity (σ):	1.98	1.93	2.31	5
Body 2475	e'	52.7956	Relative Permittivity (ϵ_r):	52.80	52.67	0.24	5	
	e"	14.7706	Conductivity (σ):	2.03	1.99	2.40	5	
5/4/2012	Body 1900	e'	53.8727	Relative Permittivity (ϵ_r):	53.87	53.30	1.07	5
		e"	14.4731	Conductivity (σ):	1.53	1.52	0.59	5
	Body 1850	e'	54.0064	Relative Permittivity (ϵ_r):	54.01	53.30	1.33	5
		e"	14.2953	Conductivity (σ):	1.47	1.52	-3.26	5
	Body 1880	e'	53.9380	Relative Permittivity (ϵ_r):	53.94	53.30	1.20	5
		e"	14.4240	Conductivity (σ):	1.51	1.52	-0.80	5
	Body 1910	e'	53.8329	Relative Permittivity (ϵ_r):	53.83	53.30	1.00	5
		e"	14.4973	Conductivity (σ):	1.54	1.52	1.29	5

12. System Performance Check

The system performance check is performed prior to any usage of the system in order to verify SAR system measurement accuracy. The system performance check verifies that the system operates within its specifications of $\pm 10\%$.

12.1. System Performance Check Measurement Conditions

- The measurements were performed in the flat section of the TWIN SAM or ELI phantom, shell thickness: 2.0 ± 0.2 mm (bottom plate) filled with Body or Head simulating liquid of the following parameters.
- The DASY system with an E-Field Probe was used for the measurements.
- The dipole was mounted on the small tripod so that the dipole feed point was positioned below the center marking of the flat phantom section and the dipole was oriented parallel to the body axis (the long side of the phantom). The standard measuring distance was 10 mm (above 1 GHz) and 15 mm (below 1 GHz) from dipole center to the simulating liquid surface.
- The coarse grid with a grid spacing of 15 mm was aligned with the dipole.
 For 5 GHz band - The coarse grid with a grid spacing of 10 mm was aligned with the dipole.
- Special 7x7x7 (below 3 GHz) and/or 8x8x7 (above 3 GHz) fine cube was chosen for the cube.
- Distance between probe sensors and phantom surface was set to 3 mm.
 For 5 GHz band - Distance between probe sensors and phantom surface was set to 2.5 mm
- The dipole input power (forward power) was 100 mW.
- The results are normalized to 1 W input power.

12.2. Reference SAR Values for System Performance Check

The reference SAR values can be obtained from the calibration certificate of system validation dipoles

System Dipole	Serial No.	Cal. Date	Freq. (MHz)	SAR Measured (mW/g)		
				1g/10g	Head	Body
D750V3	1019	2/9/12	750	1g	8.64	8.84
				10g	5.64	5.84
D835V2	4d002	3/6/12	835	1g	9.24	9.64
				10g	6.04	6.32
D1900V2	5d043	11/10/11	1900	1g	40.8	42.0
				10g	21.2	22.0
D2450V2	748	2/7/12	2450	1g	53.6	50.8
				10g	24.8	23.6

12.3. System Performance Check Results

Date Tested	System Dipole		T.S. Liquid	SAR Measured (Normalized to 1 W)		Target (Ref. Value)	Delta (%)	Tolerance (%)
	Type	Serial No.		1g	10g			
4/26/2012	D1900V2	5d043	Body	1g	42.0	42.0	0.00	±10
				10g	22.1	22.0	0.45	
4/27/2012	D1900V2	5d043	Head	1g	41.1	40.8	0.74	±10
				10g	21.3	21.2	0.47	
4/28/2012	D835V2	4d002	Head	1g	9.79	9.64	1.56	±10
				10g	6.41	6.32	1.42	
4/30/2012	D835V2	4d002	Body	1g	9.67	10.2	-5.20	±10
				10g	6.34	6.68	-5.09	
5/1/2012	D2450	748	Head	1g	49.4	53.6	-7.84	±10
				10g	22.7	24.8	-8.47	
5/1/2012	D2450	748	Body	1g	50.9	50.8	0.20	±10
				10g	23.6	23.6	0.00	
5/1/2012	D750V3	1019	Body	1g	8.91	8.84	0.79	±10
				10g	5.64	5.84	-3.42	
5/2/2012	D750V3	1019	Head	1g	8.95	8.64	3.59	±10
				10g	5.54	5.64	-1.77	
5/3/2012	D750V3	1019	Body	1g	9.72	8.84	9.95	±10
				10g	6.15	5.84	5.31	
5/3/2012	D835V2	4d002	Body	1g	9.81	10.2	-3.82	±10
				10g	6.37	6.68	-4.64	
5/4/2012	D2450V2	748	Body	1g	54.10	50.8	6.50	±10
				10g	24.90	23.64	5.33	
5/4/2012	D1900V2	5d043	Body	1g	41.2	42.0	-1.90	±10
				10g	21.7	22.0	-1.36	

13. SAR Test Results

13.1. GSM850

13.1.1. Head SAR

Test Position	Mode	Ch #.	Freq. (MHz)	Avg Pwr (dBm)	SAR (mW/g)		Note
					1-g	10-g	
Left Touch	Voice	128	824.20	32.8			1
		190	836.60	32.6	0.157	0.126	
		251	848.80	32.5			1
Left Tilt (15°)	Voice	128	824.20	32.8			1
		190	836.60	32.6	0.094	0.076	
		251	848.80	32.5			1
Right Touch	Voice	128	824.20	32.8			1
		190	836.60	32.6	0.153	0.123	
		251	848.80	32.5			1
Right Tilt (15°)	Voice	128	824.20	32.8			1
		190	836.60	32.6	0.099	0.079	
		251	848.80	32.5			1

13.1.2. Body SAR

Test Position	Mode	Dist. (mm)	Ch #.	Freq. (MHz)	Avg Pwr (dBm)	SAR (mW/g)		Note
						1-g	10-g	
Rear	GPRS 2 slots	10	128	824.20	31.5			1
			190	836.60	31.3	0.703	0.432	
			190	836.60	31.3	0.674	0.385	2
			251	848.80	31.3			1
Front	GPRS 2 slots	10	128	824.20	31.5			1
			190	836.60	31.3	0.307	0.219	
			251	848.80	31.3			1

GPRS/EDGE is not supported Hotspot function

Note(s):

- SAR test was performed in the middle channel only as the measured level was < 50% of the SAR limit as stated in FCC "Public Notice DA 02-1438" by the SCC-34/SC-2. Testing in the low and high channel is optional.
- With headset attached.

13.2. GSM1900

13.2.1. Head SAR

Test Position	Mode	Ch #.	Freq. (MHz)	Avg Pwr (dBm)	SAR (mW/g)		Note
					1-g	10-g	
Left Touch	Voice	512	1850.2	29.2			1
		661	1880.0	29.3	0.142	0.094	
		810	1909.8	29.2			1
Left Tilt (15°)	Voice	512	1850.2	29.2			1
		661	1880.0	29.3	0.092	0.057	
		810	1909.8	29.2			1
Right Touch	Voice	512	1850.2	29.2			1
		661	1880.0	29.3	0.287	0.185	
		810	1909.8	29.2			1
Right Tilt (15°)	Voice	512	1850.2	29.2			1
		661	1880.0	29.3	0.072	0.045	
		810	1909.8	29.2			1

13.2.2. Body SAR

Test Position	Mode	Dist. (mm)	Ch #.	Freq. (MHz)	Avg Pwr (dBm)	SAR (mW/g)		Note
						1-g	10-g	
Rear	GPRS 2 slots	10	512	1850.2	28.5			1
			661	1880.0	28.5	0.709	0.404	
			661	1880.0	28.5	0.708	0.402	2
			810	1909.8	28.5			1
Front	GPRS 2 slots	10	512	1850.2	28.5			1
			661	1880.0	28.5	0.385	0.235	
			810	1909.8	28.5			1

GPRS/EDGE is not supported Hotspot function

Note(s):

1. According to FCC "Public Notice DA 02-1438" by the SCC-34/SC-2, when the SAR measured for the middle channel is < 50% of the SAR limit, testing for the low and high channel is optional.
2. With headset attached.

13.3. W-CDMA Band II

Test reduction considerations

Body SAR is not required for handsets with HSPA capabilities when the maximum average output of each RF channel with HSUPA/HSDPA active is less than ¼ dB higher than that measured without HSUPA/HSDPA using 12.2 kbps RMC and the maximum SAR for 12.2kbps RMC is ≤ 75% of the SAR limit as per KDB 941225 D01

13.3.1. Head SAR

Test Position	Mode	Ch #.	Freq. (MHz)	Avg Pwr (dBm)	SAR (mW/g)		Note
					1-g	10-g	
Left Touch	Rel 99 RMC 12.2kbps	9262	1852.4	22.8			1
		9400	1880.0	23.0	0.243	0.160	
		9538	1907.6	22.8			1
Left Tilt (15°)	Rel 99 RMC 12.2kbps	9262	1852.4	22.8			1
		9400	1880.0	23.0	0.156	0.098	
		9538	1907.6	22.8			1
Right Touch	Rel 99 RMC 12.2kbps	9262	1852.4	22.8			1
		9400	1880.0	23.0	0.564	0.362	
		9538	1907.6	22.8			1
Right Tilt (15°)	Rel 99 RMC 12.2kbps	9262	1852.4	22.8			1
		9400	1880.0	23.0	0.131	0.082	
		9538	1907.6	22.8			1

13.3.2. Body & Hotspot SAR

Test Position	Mode	Dist. (mm)	Ch #.	Freq. (MHz)	Avg Pwr (dBm)	SAR (mW/g)		Note
						1-g	10-g	
Rear	Rel 99 RMC 12.2kbps	10	9262	1852.4	22.8	0.824	0.467	
			9400	1880.0	23.0	0.828	0.459	
			9400	1880.0	23.0	0.815	0.456	2
			9538	1907.6	22.8	0.677	0.371	
Front	Rel 99 RMC 12.2kbps	10	9262	1852.4	22.8			1
			9400	1880.0	23.0	0.410	0.242	
Edge 1	Rel 99 RMC 12.2kbps	10	9262	1852.4	22.8			3
			9400	1880.0	23.0			3
			9538	1907.6	22.8			3
Edge 2	Rel 99 RMC 12.2kbps	10	9262	1852.4	22.8			1
			9400	1880.0	23.0	0.312	0.186	
Edge 3	Rel 99 RMC 12.2kbps	10	9262	1852.4	22.8			1
			9400	1880.0	23.0	0.457	0.242	
			9538	1907.6	22.8			1
Edge 4	Rel 99 RMC 12.2kbps	10	9262	1852.4	22.8			3
			9400	1880.0	23.0			3
			9538	1907.6	22.8			3

Note(s):

1. According to FCC "Public Notice DA 02-1438" by the SCC-34/SC-2, when the SAR measured for the middle channel is < 50% of the SAR limit, testing for the low and high channel is optional.
2. With headset attached.
3. SAR is not required because the distance from the tested antenna to this edge is greater than 2.5 cm.

13.4. CDMA BC0

13.4.1. Head SAR

Test Position	Mode	Ch #.	Freq. (MHz)	Avg Pwr (dBm)	SAR (mW/g)		Note
					1-g	10-g	
Left Touch	1xRTT (RC3 SO55)	1013	824.7	24.9			1
		384	836.5	24.9	0.261	0.210	
		777	848.3	24.9			1
Left Tilt (15°)	1xRTT (RC3 SO55)	1013	824.7	24.9			1
		384	836.5	24.9	0.154	0.123	
		777	848.3	24.9			1
Right Touch	1xRTT (RC3 SO55)	1013	824.7	24.9			1
		384	836.5	24.9	0.223	0.177	
		777	848.3	24.9			1
Right Tilt (15°)	1xRTT (RC3 SO55)	1013	824.7	24.9			1
		384	836.5	24.9	0.152	0.120	
		777	848.3	24.9			1
Test Position	Mode	Ch #.	Freq. (MHz)	Avg Pwr (dBm)	SAR (mW/g)		Note
Left Touch	1xEVDO (Rel. 0)	1013	824.7	24.3			1
		384	836.5	24.4	0.332	0.208	
		777	848.3	24.2			1
Left Tilt (15°)	1xEVDO (Rel. 0)	1013	824.7	24.3			1
		384	836.5	24.4	0.260	0.177	
		777	848.3	24.2			1
Right Touch	1xEVDO (Rel. 0)	1013	824.7	24.3			1
		384	836.5	24.4	0.174	0.119	
		777	848.3	24.2			1
Right Tilt (15°)	1xEVDO (Rel. 0)	1013	824.7	24.3			1
		384	836.5	24.4	0.148	0.106	
		777	848.3	24.2			1

Note(s):

1. According to FCC "Public Notice DA 02-1438" by the SCC-34/SC-2, when the SAR measured for the middle channel is < 50% of the SAR limit, testing for the low and high channel is optional.

13.4.2. Body & Hotspot SAR

Test Position	Mode	Dist. (mm)	Ch #.	Freq. (MHz)	Avg Pwr (dBm)	SAR (mW/g)		Note
						1-g	10-g	
Rear	1xRTT (RC3 SO32)	10	1013	824.7	24.9	0.700	0.442	
			384	836.5	25.0	0.822	0.501	
			777	848.3	25.0	0.864	0.516	
			777	848.3	25.0	0.894	0.542	2
Front	1xRTT (RC3 SO32)	10	1013	824.7	24.9			1
			384	836.5	25.0	0.364	0.264	
			777	848.3	25.0			1
Edge 1	1xRTT (RC3 SO32)	10	1013	824.7	24.9			3
			384	836.5	25.0			3
			777	848.3	25.0			3
Edge 2	1xRTT (RC3 SO32)	10	1013	824.7	24.9			1
			384	836.5	25.0	0.124	0.086	
			777	848.3	25.0			1
Edge 3	1xRTT (RC3 SO32)	10	1013	824.7	24.9			1
			384	836.5	25.0	0.189	0.112	
			777	848.3	25.0			1
Edge 4	1xRTT (RC3 SO32)	10	1013	824.7	24.9			3
			384	836.5	25.0			3
			777	848.3	25.0			3
Test Position	Mode	Dist. (mm)	Ch #.	Freq. (MHz)	Avg Pwr (dBm)	SAR (mW/g)		Note
Rear	1xEVDO (Rel. 0)	10	1013	824.7	24.3			1
			384	836.5	24.4	0.493	0.281	
			384	836.5	24.4	0.482	0.275	2
			777	848.3	24.2			1
Front	1xEVDO (Rel. 0)	10	1013	824.7	24.3			1
			384	836.5	24.4	0.162	0.115	
			777	848.3	24.2			1
Edge 1	1xEVDO (Rel. 0)	10	1013	824.7	24.3			1
			384	836.5	24.4	0.094	0.064	
			777	848.3	24.2			1
Edge 2	1xEVDO (Rel. 0)	10	1013	824.7	24.3			1
			384	836.5	24.4	0.153	0.086	
			777	848.3	24.2			1
Edge 3	1xEVDO (Rel. 0)	10	1013	824.7	24.3			3
			384	836.5	24.4			3
			777	848.3	24.2			3
Edge 4	1xEVDO (Rel. 0)	10	1013	824.7	24.3			3
			384	836.5	24.4			3
			777	848.3	24.2			3

Note(s):

1. According to FCC "Public Notice DA 02-1438" by the SCC-34/SC-2, when the SAR measured for the middle channel is < 50% of the SAR limit, testing for the low and high channel is optional.
2. With headset attached.
3. SAR is not required because the distance from the tested antenna to this edge is greater than 2.5 cm.

13.5. CDMA BC1

13.5.1. Head SAR

Test Position	Mode	Ch #.	Freq. (MHz)	Avg Pwr (dBm)	SAR (mW/g)		Note
					1-g	10-g	
Left Touch	1xRTT (RC3 SO55)	25	1851.25	24.3			1
		600	1880.00	24.2	0.348	0.228	
		1175	1908.75	24.3			1
Left Tilt (15°)	1xRTT (RC3 SO55)	25	1851.25	24.3			1
		600	1880.00	24.2	0.241	0.148	
		1175	1908.75	24.3			1
Right Touch	1xRTT (RC3 SO55)	25	1851.25	24.3	0.783	0.508	
		600	1880.00	24.2	0.801	0.517	
		1175	1908.75	24.3	0.604	0.387	
Right Tilt (15°)	1xRTT (RC3 SO55)	25	1851.25	24.3			1
		600	1880.00	24.2	0.210	0.130	
		1175	1908.75	24.3			1
Test Position	Mode	Ch #.	Freq. (MHz)	Avg Pwr (dBm)	SAR (mW/g)		Note
Left Touch	1xEVDO (Rel. 0)	25	1851.25	24.2			1
		600	1880.00	24.3	0.613	0.292	
		1175	1908.75	24.2			1
Left Tilt (15°)	1xEVDO (Rel. 0)	25	1851.25	24.2			1
		600	1880.00	24.3	0.282	0.139	
		1175	1908.75	24.2			1
Right Touch	1xEVDO (Rel. 0)	25	1851.25	24.2			1
		600	1880.00	24.3	0.138	0.080	
		1175	1908.75	24.2			1
Right Tilt (15°)	1xEVDO (Rel. 0)	25	1851.25	24.2			1
		600	1880.00	24.3	0.062	0.037	
		1175	1908.75	24.2			1

Note(s):

1. According to FCC "Public Notice DA 02-1438" by the SCC-34/SC-2, when the SAR measured for the middle channel is < 50% of the SAR limit, testing for the low and high channel is optional.
2. With headset attached.

13.5.2. Body & Hotspot SAR

Test Position	Mode	Dist. (mm)	Ch #.	Freq. (MHz)	Avg Pwr (dBm)	SAR (mW/g)		Note
						1-g	10-g	
Rear	1xRTT (RC3 SO32)	10	25	1851.25	24.2	1.240	0.699	
			25	1851.25	24.2	1.240	0.692	2
			600	1880.00	24.2	1.200	0.658	
			1175	1908.75	24.3	1.030	0.571	
Front	1xRTT (RC3 SO32)	10	25	1851.25	24.2			1
			600	1880.00	24.2	0.582	0.345	
			1175	1908.75	24.3			1
Edge 1	1xRTT (RC3 SO32)	10	25	1851.25	24.2			3
			600	1880.00	24.2			3
			1175	1908.75	24.3			3
Edge 2	1xRTT (RC3 SO32)	10	25	1851.25	24.2			1
			600	1880.00	24.2	0.409	0.246	
			1175	1908.75	24.3			1
Edge 3	1xRTT (RC3 SO32)	10	25	1851.25	24.2			1
			600	1880.00	24.2	0.643	0.338	
			1175	1908.75	24.3			1
Edge 4	1xRTT (RC3 SO32)	10	25	1851.25	24.2			3
			600	1880.00	24.2			3
			1175	1908.75	24.3			3
Test Position	Mode	Dist. (mm)	Ch #.	Freq. (MHz)	Avg Pwr (dBm)	SAR (mW/g)		Note
Rear	1xEVDO (Rel. 0)	10	25	1851.25	24.2	0.918	0.476	
			600	1880.00	24.3	1.030	0.532	
			600	1880.00	24.3	1.030	0.530	2
			1175	1908.75	24.2	0.787	0.403	
Front	1xEVDO (Rel. 0)	10	25	1851.25	24.2			1
			600	1880.00	24.3	0.122	0.068	
			1175	1908.75	24.2			1
Edge 1	1xEVDO (Rel. 0)	10	25	1851.25	24.2			1
			600	1880.00	24.3	0.061	0.036	
			1175	1908.75	24.2			1
Edge 2	1xEVDO (Rel. 0)	10	25	1851.25	24.2			1
			600	1880.00	24.3	0.436	0.235	
			1175	1908.75	24.2			1
Edge 3	1xEVDO (Rel. 0)	10	25	1851.25	24.2			3
			600	1880.00	24.3			3
			1175	1908.75	24.2			3
Edge 4	1xEVDO (Rel. 0)	10	25	1851.25	24.2			3
			600	1880.00	24.3			3
			1175	1908.75	24.2			3

Note(s):

1. According to FCC "Public Notice DA 02-1438" by the SCC-34/SC-2, when the SAR measured for the middle channel is < 50% of the SAR limit, testing for the low and high channel is optional.
2. With headset attached.
3. SAR is not required because the distance from the tested antenna to this edge is greater than 2.5 cm.

13.6. LTE Band 13

13.6.1. Head SAR

Test Position	Mode	UL Ch #.	Freq. (MHz)	UL RB Allocatio	UL RB Start	MPR	Avg Pwr (dBm)	SAR (mW/g)		Note
								1-g	10-g	
Left Touch	QPSK	23230	782.0	25	12	1	22.5	0.076	0.060	
				1	0	0	23.5	0.114	0.090	
				1	49	0	23.4	0.134	0.103	
				50	0	1	22.3			1
	16QAM	23230	782.0	25	12	1	21.4	0.061	0.048	
				1	0	0	22.4	0.094	0.073	
				1	49	0	22.4	0.110	0.085	
				50	0	1	21.4			1
Left Tilt (15°)	QPSK	23230	782.0	25	12	1	22.5	0.054	0.043	
				1	0	0	23.5	0.081	0.065	
				1	49	0	23.4	0.094	0.075	
				50	0	1	22.3			1
	16QAM	23230	782.0	25	12	1	21.4	0.045	0.036	
				1	0	0	22.4	0.070	0.056	
				1	49	0	22.4	0.077	0.061	
				50	0	1	21.4			1
Right Touch	QPSK	23230	782.0	25	12	1	22.5	0.073	0.057	
				1	0	0	23.5	0.108	0.084	
				1	49	0	23.4	0.112	0.087	
				50	0	1	22.3			1
	16QAM	23230	782.0	25	12	1	21.4	0.054	0.043	
				1	0	0	22.4	0.085	0.067	
				1	49	0	22.4	0.095	0.074	
				50	0	1	21.4			1
Right Tilt (15°)	QPSK	23230	782.0	25	12	1	22.5	0.033	0.026	
				1	0	0	23.5	0.052	0.042	
				1	49	0	23.4	0.053	0.043	
				50	0	1	22.3			1
	16QAM	23230	782.0	25	12	1	21.4	0.032	0.026	
				1	0	0	22.4	0.061	0.049	
				1	49	0	22.4	0.064	0.052	
				50	0	1	21.4			1

Note(s):

- Testing for 100% RB allocation is not required because the SAR value for 50% RB allocation is $\leq 1.45W/Kg$, as per KDB 941225 D05 SAR for LTE Devices v01

13.6.2. Body & Hotspot SAR

Test Position	Mode	Dist. (mm)	UL Ch #.	Freq. (MHz)	UL RB Allocatio	UL RB Start	MPR	Avg Pwr (dBm)	SAR (mW/g)		Note	
									1-g	10-g		
Rear	QPSK	10	23230	782.0	25	12	1	22.5	0.370	0.223		
					1	0	0	23.5	0.520	0.313		
					1	49	0	23.4	0.576	0.348		
					1	49	0	23.4	0.571	0.340	2	
					50	0	1	22.3			1	
	16QAM	10	23230	782.0	25	12	1	21.4	0.288	0.174		
					1	0	0	22.4	0.416	0.250		
					1	49	0	22.4	0.472	0.282		
					1	49	0	22.4	0.467	0.284	2	
					50	0	1	21.4			1	
Front	QPSK	10	23230	782.0	25	12	1	22.5	0.152	0.096		
					1	0	0	23.5	0.213	0.135		
					1	49	0	23.4	0.232	0.146		
					1	49	0	23.4	0.232	0.147	2	
					50	0	1	22.3			1	
	16QAM	10	23230	782.0	25	12	1	21.4	0.122	0.077		
					1	0	0	22.4	0.169	0.108		
					1	49	0	22.4	0.191	0.122		
					50	0	1	21.4			1	
					Edge 3	QPSK	10	23230	782.0	25	12	1
1	0	0	23.5	0.233						0.146		
1	49	0	23.4	0.261						0.165		
50	0	1	22.3								1	
16QAM	10	23230	782.0	25						12	1	21.4
				1		0	0	22.4	0.183	0.115		
				1		49	0	22.4	0.215	0.136		
				50		0	1	21.4			1	
				Edge 4		QPSK	10	23230	782.0	25	12	1
1	0	0	23.5							0.128	0.090	
1	49	0	23.4		0.143					0.099		
50	0	1	22.3								1	
16QAM	10	23230	782.0		25					12	1	21.4
					1	0	0	22.4	0.105	0.073		
					1	49	0	22.4	0.121	0.084		
					50	0	1	21.4			1	

Note(s):

1. Testing for 100% RB allocation is not required because the SAR value for 50% RB allocation is $\leq 1.45W/Kg$, as per KDB 941225 D05 SAR for LTE Devices v01
2. With headset attached.

13.7. Wi-Fi (2.4 GHz Band)

13.7.1. Head SAR

Test Position	Mode	Ch #.	Freq. (MHz)	Avg Pwr (dBm)	SAR (mW/g)		Note
					1-g	10-g	
Left Touch	802.11b	1	2412	12.4			
		6	2437	12.7			
		11	2462	12.8	0.115	0.051	
Left Tilt (15°)	802.11b	1	2412	12.4			
		6	2437	12.7			
		11	2462	12.8	0.105	0.051	
Right Touch	802.11b	1	2412	12.4			
		6	2437	12.7			
		11	2462	12.8	0.151	0.068	
Right Tilt (15°)	802.11b	1	2412	12.4			
		6	2437	12.7			
		11	2462	12.8	0.115	0.055	

13.7.2. Body & Hotspot SAR

Test Position	Mode	Dist. (mm)	Ch #.	Freq. (MHz)	Avg Pwr (dBm)	SAR (mW/g)		Note
						1-g	10-g	
Rear	802.11b	10	1	2412	12.4			1
			6	2437	12.7			1
			11	2462	12.8	0.139	0.069	
			11	2462	12.8	0.121	0.060	2
Front	802.11b	10	1	2412	12.4			1
			6	2437	12.7			1
			11	2462	12.8	0.050	0.027	
Edge 1	802.11b	10	1	2412	12.4			1
			6	2437	12.7			1
			11	2462	12.8	0.055	0.029	
Edge 2	802.11b	10	1	2412	12.4			3
			6	2437	12.7			3
			11	2462	12.8			3
Edge 3	802.11b	10	1	2412	12.4			3
			6	2437	12.7			3
			11	2462	12.8			3
Edge 4	802.11b	10	1	2412	12.4			3
			6	2437	12.7			3
			11	2462	12.8			3

Note(s):

- For frequency bands with an operating range of < 100 MHz, when the SAR measured for the highest output power channel within is ≤ 0.8 W/kg, SAR for the remaining channels is not required. Per KDB 447498 1) e) i)
- With headset attached.
- SAR is not required because the distance from the tested antenna to this edge is greater than 2.5 cm.

14. Summary of Highest SAR Values

Results for highest SAR values for each frequency band and mode

Technology/Band	Test configuration		Mode	Highest 1g SAR (W/kg)
GSM850	Head	Left Touch	GSM	0.157
	Body	Rear	GPRS 2 slot	0.703
GSM1900	Head	Right Touch	GSM	0.287
	Body & Hotspot	Rear	GPRS 2 slot	0.709
W-CDMA Band II	Head	Right Touch	Rel 99 RMC 12.2kbps	0.564
	Body & Hotspot	Rear	Rel 99 RMC 12.2kbps	0.828
CDMA BC0	Head	Left Touch	1xRTT (RC3, SO55)	0.261
	Head	Left Touch	1xEVDO (Rel.0)	0.332
	Body & Hotspot	Rear	1xRTT (RC3, SO32) with headset	0.894
	Body & Hotspot	Rear	1xEVDO (Rel.0)	0.493
CDMA BC1	Head	Right Touch	1xRTT (RC3, SO55)	0.801
	Head	Left Touch	1xEVDO (Rel.0)	0.613
	Body & Hotspot	Rear	1xRTT (RC3, SO32)	1.24
	Body & Hotspot	Rear	1xEVDO (Rel.0)	1.03
LTE band 13	Head	Left Touch	10 MHz (QPSK) RB 1/49	0.134
	Body & Hotspot	Rear	10 MHz (QPSK) RB 1/49	0.576
WiFi 2.4 GHz	Head	Right Touch	802.11b 1Mbps	0.151
	Body & Hotspot	Rear	802.11b 1Mbps	0.139

14.1. SAR Plots (from Summary of Highest SAR Values)

Test Laboratory: UL CCS SAR Lab C

Date: 4/28/2012

GSM850

Frequency: 836.6 MHz; Duty Cycle: 1:8.00018; Room Ambient Temperature: 24.0°C; Liquid Temperature: 23.0°C
Medium parameters used (interpolated): $f = 836.6$ MHz; $\sigma = 0.902$ mho/m; $\epsilon_r = 42.661$; $\rho = 1000$ kg/m³

DASY5 Configuration:

- Electronics: DAE3 Sn500; Calibrated: 7/14/2011
- Probe: EX3DV4 - SN3773; ConvF(8.79, 8.79, 8.79); Calibrated: 3/14/2012
- Sensor-Surface: 2.5mm (Mechanical Surface Detection)
- Phantom: SAM; Type: QD000P40CD; Serial: 1632

LHS/Touch_GSM ch 190/Area Scan (9x13x1): Measurement grid: dx=15mm, dy=15mm

[Info: Interpolated medium parameters used for SAR evaluation.](#)

Maximum value of SAR (measured) = 0.168 mW/g

LHS/Touch_GSM ch 190/Zoom Scan (5x5x7)/Cube 0: Measurement grid: dx=8mm, dy=8mm, dz=5mm

Reference Value = 13.774 V/m; Power Drift = 0.0038 dB

Peak SAR (extrapolated) = 0.1860

SAR(1 g) = 0.157 mW/g; SAR(10 g) = 0.126 mW/g

[Info: Interpolated medium parameters used for SAR evaluation.](#)

Maximum value of SAR (measured) = 0.171 mW/g

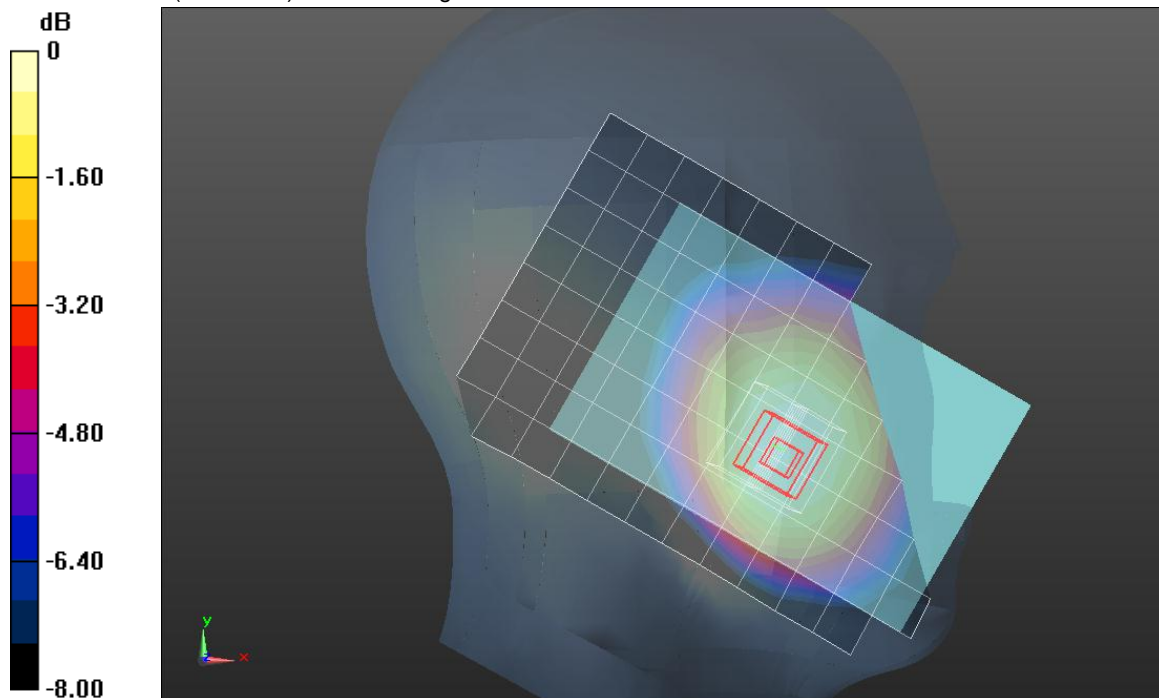

0 dB = 0.170mW/g = -15.39 dB mW/g

GSM850

Frequency: 836.6 MHz; Duty Cycle: 1:8.00018

LHS/Touch_GSM ch 190/Z Scan (1x1x21): Measurement grid: dx=20mm, dy=20mm, dz=5mm

Info: [Interpolated medium parameters used for SAR evaluation.](#)

Maximum value of SAR (measured) = 0.167 mW/g

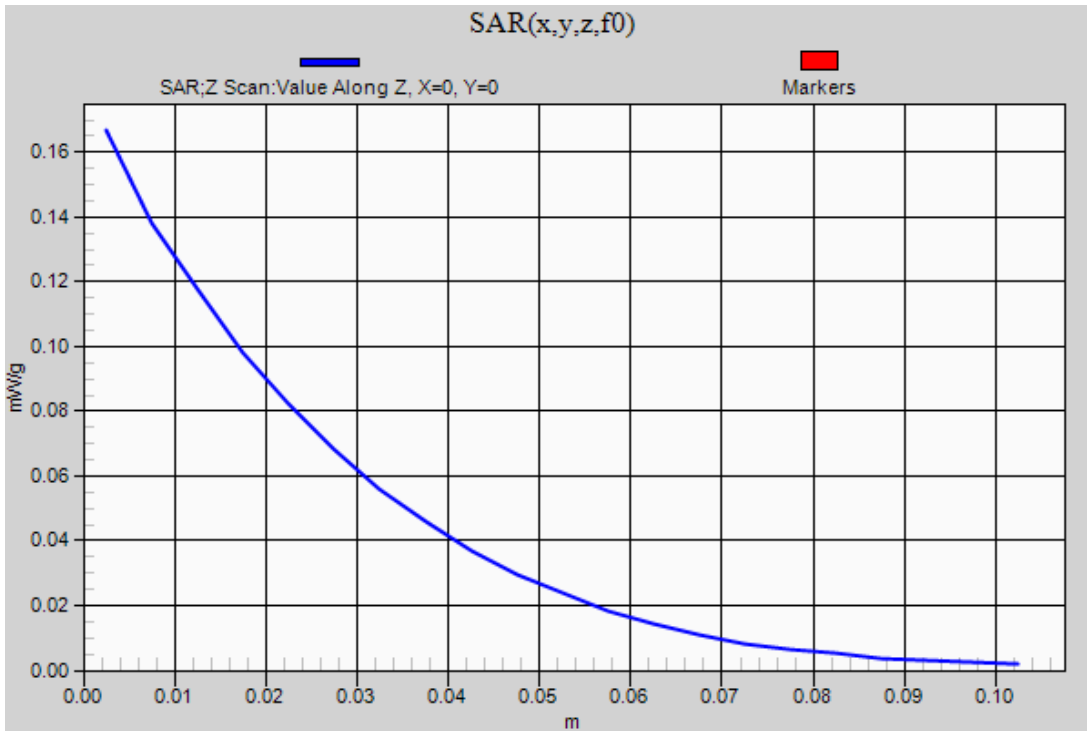

Test Laboratory: UL CCS SAR Lab C

Date: 4/30/2012

GSM850

Frequency: 836.6 MHz; Duty Cycle: 1:4.00037; Room Ambient Temperature: 24.0°C; Liquid Temperature: 23.0°C
Medium parameters used (interpolated): $f = 836.6$ MHz; $\sigma = 1.013$ mho/m; $\epsilon_r = 53.814$; $\rho = 1000$ kg/m³

DASY5 Configuration:

- Electronics: DAE3 Sn500; Calibrated: 7/14/2011
- Probe: EX3DV4 - SN3773; ConvF(8.74, 8.74, 8.74); Calibrated: 3/14/2012
- Sensor-Surface: 2.5mm (Mechanical Surface Detection (Locations From Previous Scan Used)), Sensor-Surface: 2.5mm (Mechanical Surface Detection)
- Phantom: ELI v5.0 (A); Type: QDOVA001BB; Serial: 1120

Rear/GPRS 2 slot, ch 190/Area Scan (10x13x1): Measurement grid: dx=15mm, dy=15mm

[Info: Interpolated medium parameters used for SAR evaluation.](#)

Maximum value of SAR (measured) = 0.814 mW/g

Rear/GPRS 2 slot, ch 190/Zoom Scan (5x5x7)/Cube 0: Measurement grid: dx=8mm, dy=8mm, dz=5mm

Reference Value = 28.935 V/m; Power Drift = -0.02 dB

Peak SAR (extrapolated) = 1.1530

SAR(1 g) = 0.703 mW/g; SAR(10 g) = 0.432 mW/g

[Info: Interpolated medium parameters used for SAR evaluation.](#)

Maximum value of SAR (measured) = 0.896 mW/g

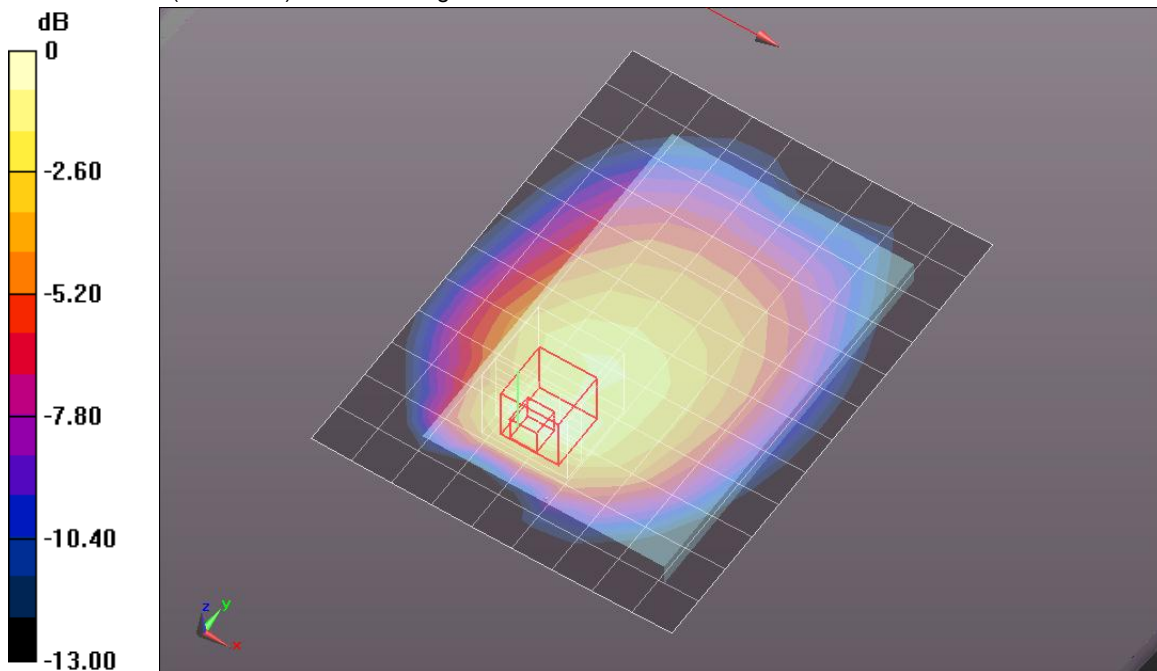

0 dB = 0.900mW/g = -0.92 dB mW/g

GSM850

Frequency: 836.6 MHz; Duty Cycle: 1:4.00037

Rear/GPRS 2 slot, ch 190/Z Scan (1x1x21): Measurement grid: dx=20mm, dy=20mm, dz=5mm

Info: [Interpolated medium parameters used for SAR evaluation.](#)

Maximum value of SAR (measured) = 0.815 mW/g

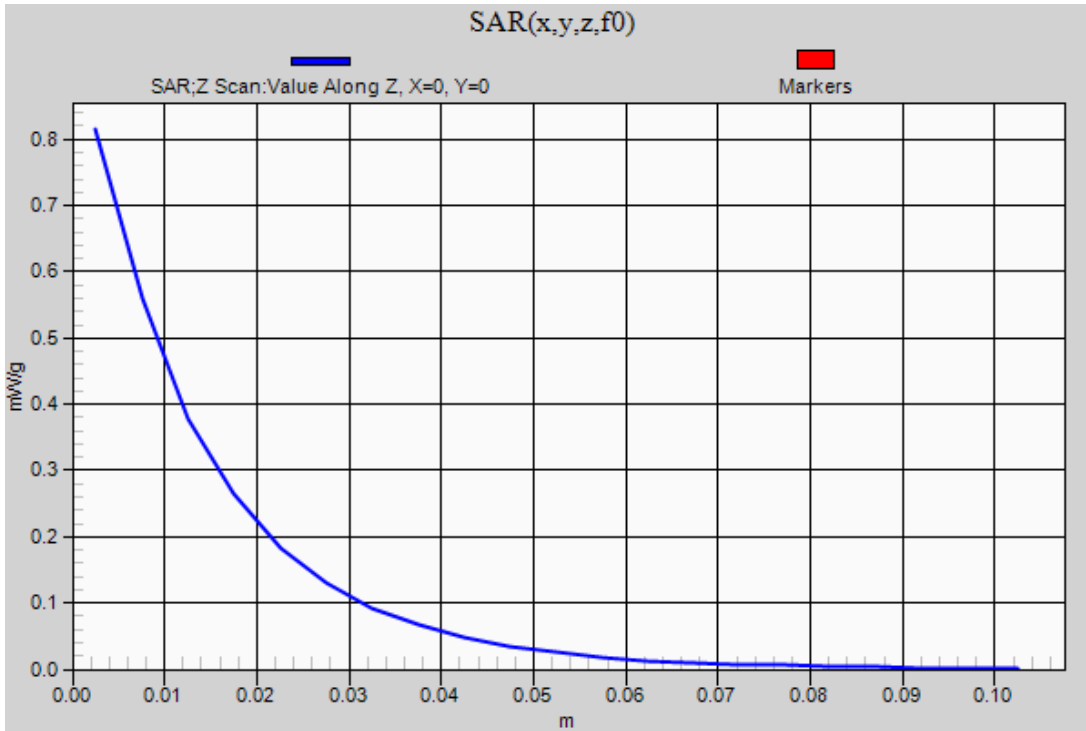

Test Laboratory: UL CCS SAR Lab C

Date: 4/27/2012

GSM1900

Frequency: 1880 MHz; Duty Cycle: 1:8.00018; Room Ambient Temperature: 24.0°C; Liquid Temperature: 23.0°C
Medium parameters used: $f = 1880$ MHz; $\sigma = 1.425$ mho/m; $\epsilon_r = 41.279$; $\rho = 1000$ kg/m³

DASY5 Configuration:

- Electronics: DAE3 Sn500; Calibrated: 7/14/2011
- Probe: EX3DV4 - SN3773; ConvF(7.51, 7.51, 7.51); Calibrated: 3/14/2012
- Sensor-Surface: 2.5mm (Mechanical Surface Detection)
- Phantom: SAM; Type: QD000P40CD; Serial: 1632

RHS/Touch_GSM ch 661/Area Scan (9x13x1): Measurement grid: dx=15mm, dy=15mm

Maximum value of SAR (measured) = 0.326 mW/g

RHS/Touch_GSM ch 661/Zoom Scan (5x5x7)/Cube 0: Measurement grid: dx=8mm, dy=8mm, dz=5mm

Reference Value = 15.607 V/m; Power Drift = -0.00078 dB

Peak SAR (extrapolated) = 0.4130

SAR(1 g) = 0.287 mW/g; SAR(10 g) = 0.185 mW/g

Maximum value of SAR (measured) = 0.335 mW/g

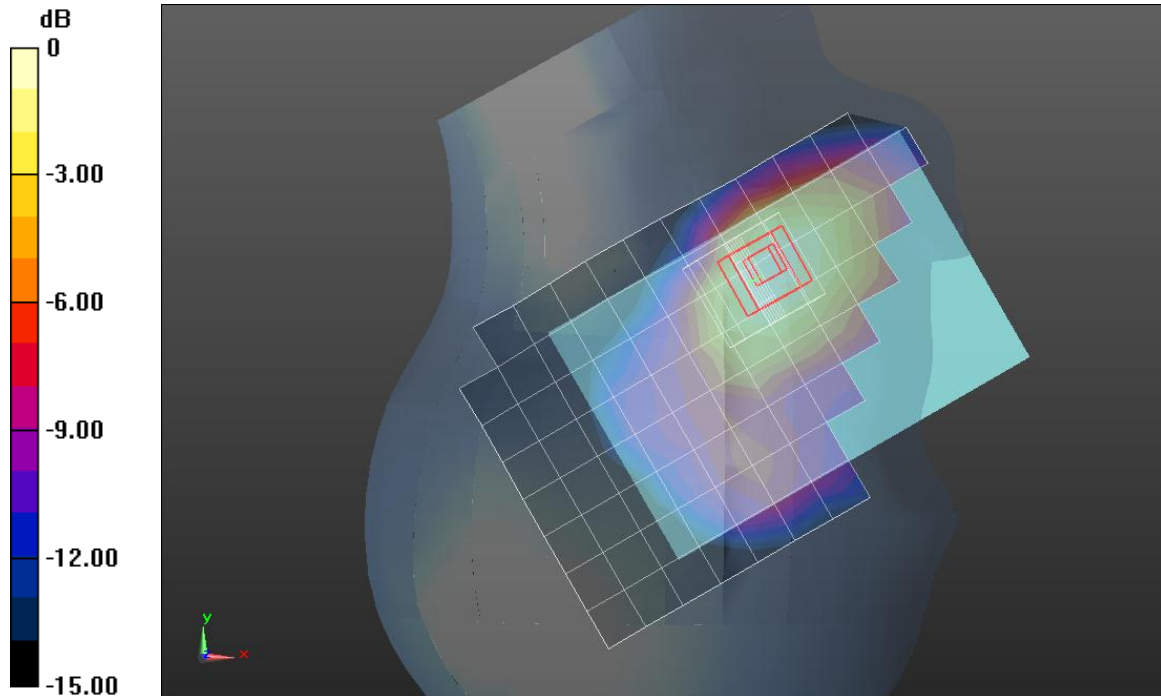

0 dB = 0.340mW/g = -9.37 dB mW/g

GSM1900

Frequency: 1880 MHz; Duty Cycle: 1:8.00018

RHS/Touch_GSM ch 661/Z Scan (1x1x21): Measurement grid: dx=20mm, dy=20mm, dz=5mm
Maximum value of SAR (measured) = 0.333 mW/g

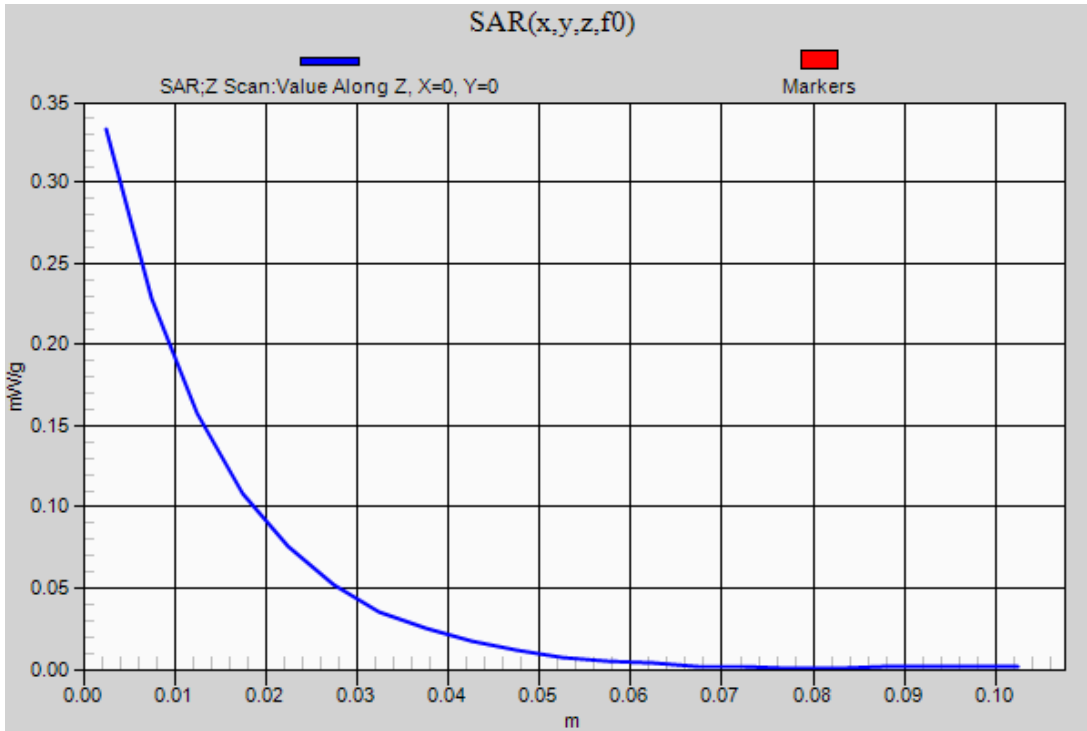

Test Laboratory: UL CCS SAR Lab C

Date: 4/26/2012

GSM1900

Frequency: 1880 MHz; Duty Cycle: 1:4.00037; Room Ambient Temperature: 24.0°C; Liquid Temperature: 23.0°C
Medium parameters used: $f = 1880$ MHz; $\sigma = 1.496$ mho/m; $\epsilon_r = 53.011$; $\rho = 1000$ kg/m³

DASY5 Configuration:

- Electronics: DAE3 Sn500; Calibrated: 7/14/2011
- Probe: EX3DV4 - SN3773; ConvF(7.11, 7.11, 7.11); Calibrated: 3/14/2012
- Sensor-Surface: 2.5mm (Mechanical Surface Detection)
- Phantom: ELI v5.0 (A); Type: QDOVA001BB; Serial: 1120

Rear/GPRS 2 slot, ch 661/Area Scan (10x13x1): Measurement grid: dx=15mm, dy=15mm

Maximum value of SAR (measured) = 0.898 mW/g

Rear/GPRS 2 slot, ch 661/Zoom Scan (5x5x7)/Cube 0: Measurement grid: dx=8mm, dy=8mm, dz=5mm

Reference Value = 24.752 V/m; Power Drift = 0.05 dB

Peak SAR (extrapolated) = 1.2220

SAR(1 g) = 0.709 mW/g; SAR(10 g) = 0.404 mW/g

Maximum value of SAR (measured) = 0.905 mW/g

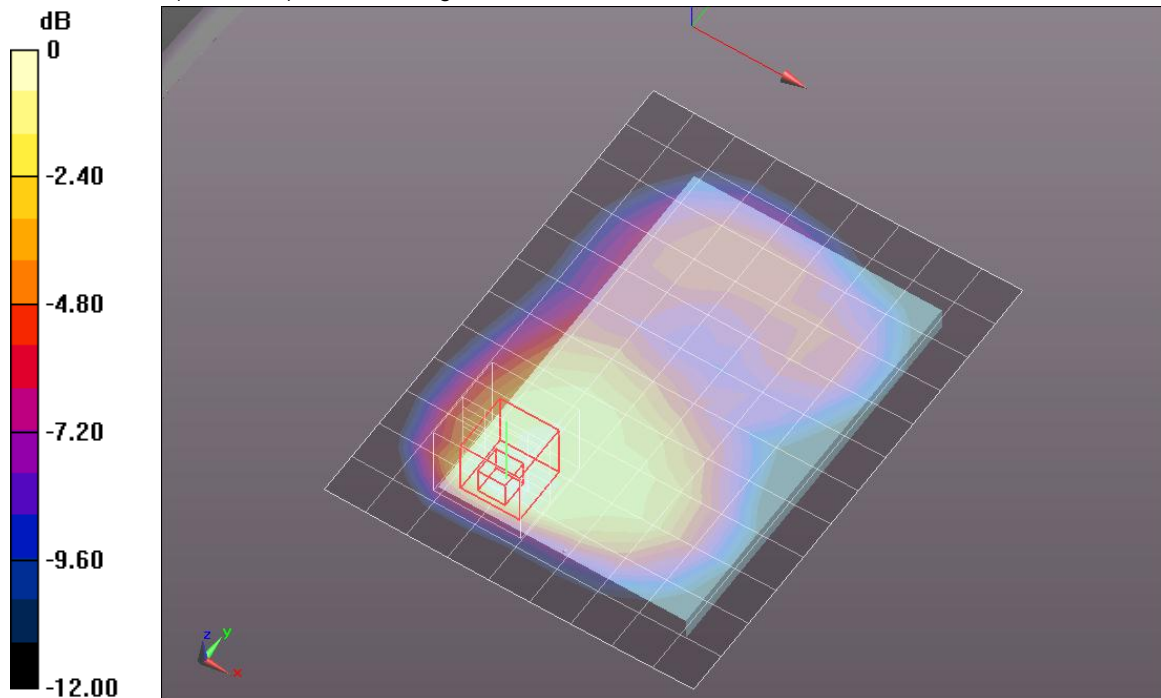

0 dB = 0.900mW/g = -0.92 dB mW/g

GSM1900

Frequency: 1880 MHz; Duty Cycle: 1:4.00037

Rear/GPRS 2 slot, ch 661/Z Scan (1x1x21): Measurement grid: dx=20mm, dy=20mm, dz=5mm

Maximum value of SAR (measured) = 0.903 mW/g

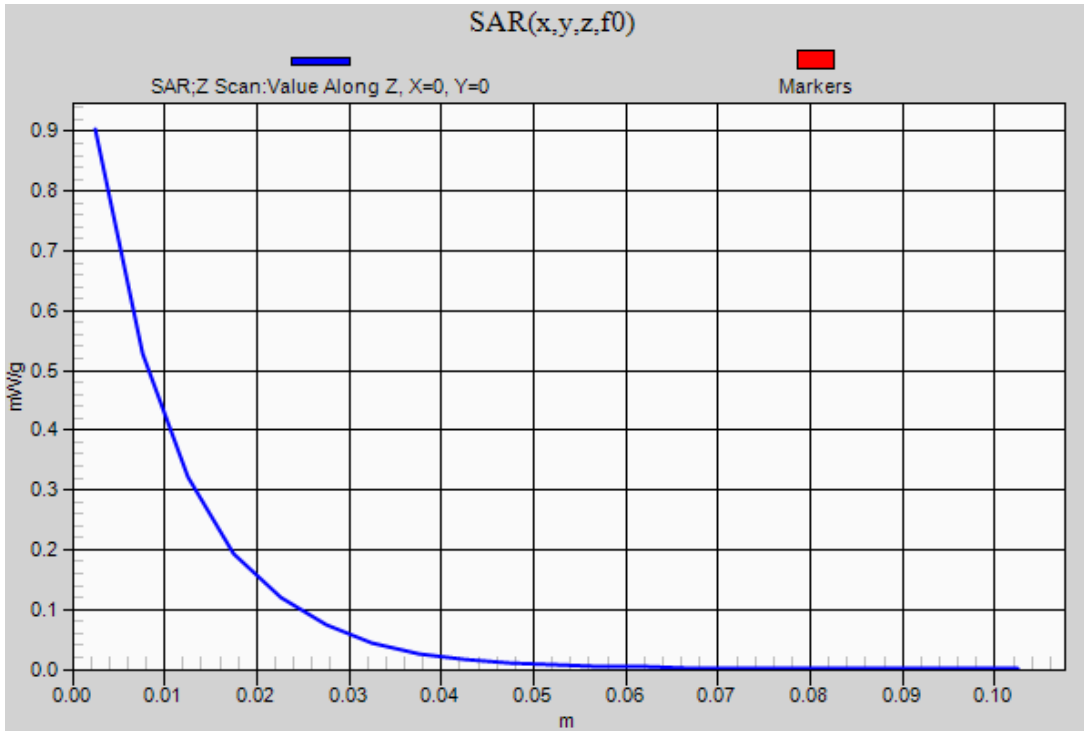

Test Laboratory: UL CCS SAR Lab C

Date: 4/27/2012

W-CDMA Band II

Frequency: 1880 MHz; Duty Cycle: 1:1; Room Ambient Temperature: 24.0°C; Liquid Temperature: 23.0°C
Medium parameters used: $f = 1880$ MHz; $\sigma = 1.425$ mho/m; $\epsilon_r = 41.279$; $\rho = 1000$ kg/m³

DASY5 Configuration:

- Electronics: DAE3 Sn500; Calibrated: 7/14/2011
- Probe: EX3DV4 - SN3773; ConvF(7.51, 7.51, 7.51); Calibrated: 3/14/2012
- Sensor-Surface: 2.5mm (Mechanical Surface Detection)
- Phantom: SAM; Type: QD000P40CD; Serial: 1632

RHS/Touch_R99, ch 9400/Area Scan (9x13x1): Measurement grid: dx=15mm, dy=15mm
Maximum value of SAR (measured) = 0.665 mW/g

RHS/Touch_R99, ch 9400/Zoom Scan (5x5x7)/Cube 0: Measurement grid: dx=8mm, dy=8mm, dz=5mm
Reference Value = 21.927 V/m; Power Drift = -0.08 dB
Peak SAR (extrapolated) = 0.8100
SAR(1 g) = 0.564 mW/g; SAR(10 g) = 0.362 mW/g
Maximum value of SAR (measured) = 0.661 mW/g

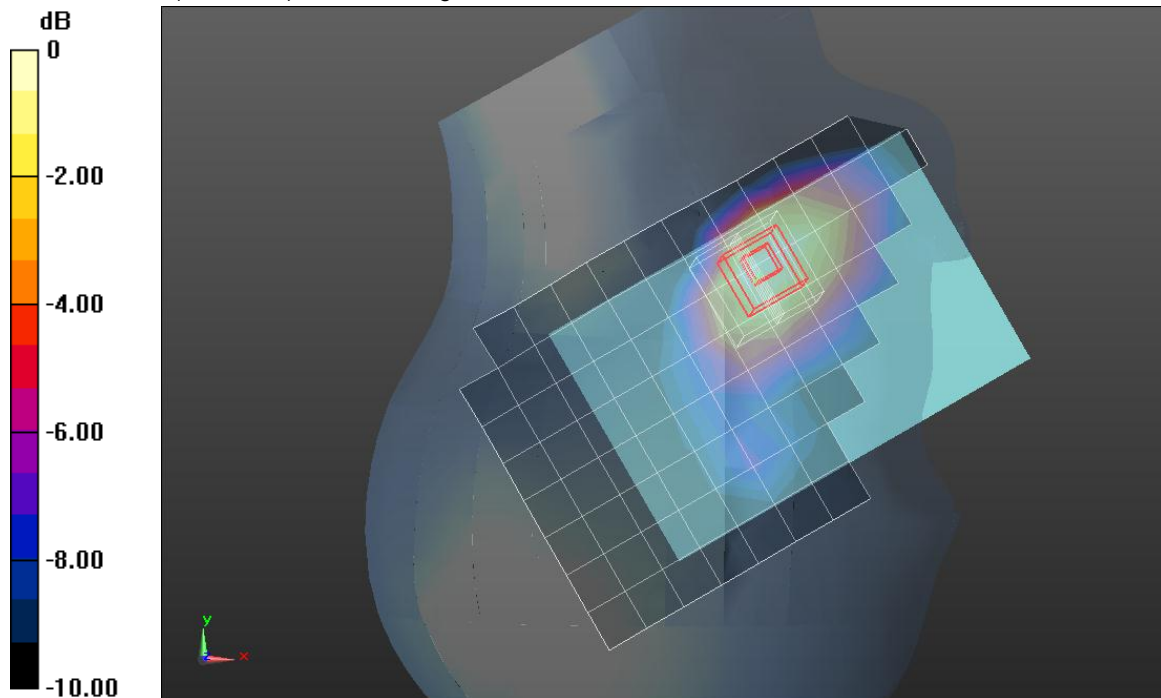

0 dB = 0.660mW/g = -3.61 dB mW/g

Test Laboratory: UL CCS SAR Lab C

Date: 4/27/2012

W-CDMA Band II

Frequency: 1880 MHz; Duty Cycle: 1:1

RHS/Touch_R99, ch 9400/Z Scan (1x1x21): Measurement grid: dx=20mm, dy=20mm, dz=5mm
Maximum value of SAR (measured) = 0.649 mW/g

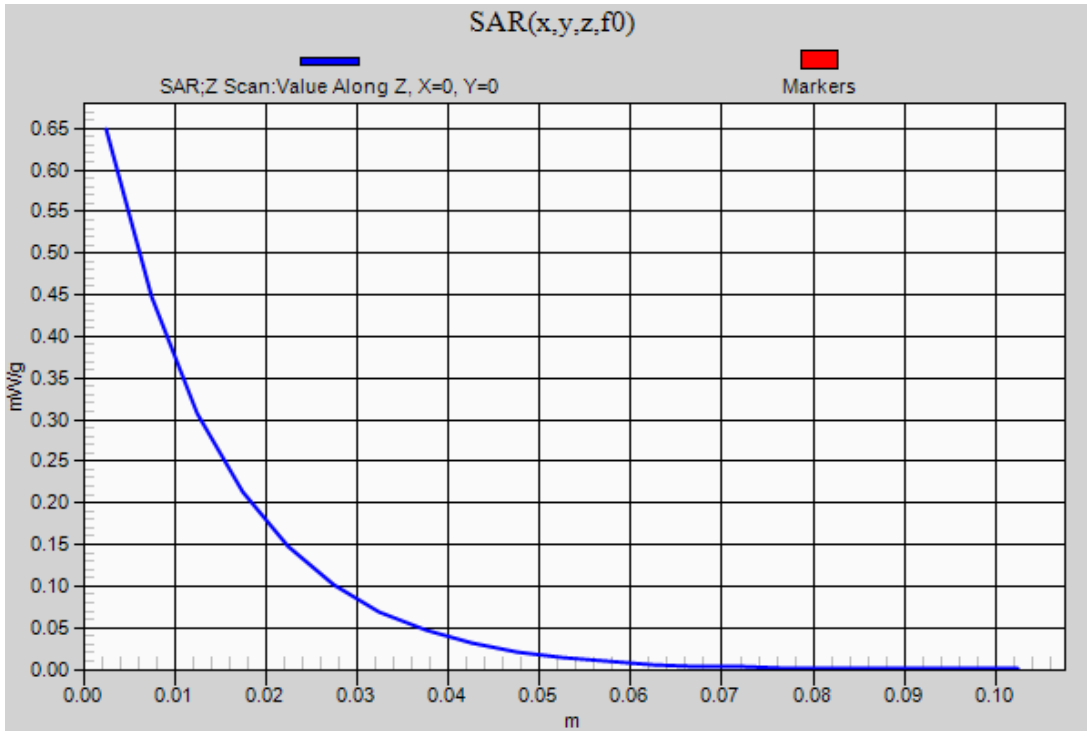

Test Laboratory: UL CCS SAR Lab C

Date: 4/26/2012

W-CDMA Band II

Frequency: 1880 MHz; Duty Cycle: 1:1; Room Ambient Temperature: 24.0°C; Liquid Temperature: 23.0°C
Medium parameters used: $f = 1880$ MHz; $\sigma = 1.496$ mho/m; $\epsilon_r = 53.011$; $\rho = 1000$ kg/m³

DASY5 Configuration:

- Electronics: DAE3 Sn500; Calibrated: 7/14/2011
- Probe: EX3DV4 - SN3773; ConvF(7.11, 7.11, 7.11); Calibrated: 3/14/2012
- Sensor-Surface: 2.5mm (Mechanical Surface Detection (Locations From Previous Scan Used)), Sensor-Surface: 2.5mm (Mechanical Surface Detection)
- Phantom: ELI v5.0 (A); Type: QDOVA001BB; Serial: 1120

Rear/R99, ch 9400/Area Scan (10x13x1): Measurement grid: dx=15mm, dy=15mm

Maximum value of SAR (measured) = 1.025 mW/g

Rear/R99, ch 9400/Zoom Scan (5x5x7)/Cube 0: Measurement grid: dx=8mm, dy=8mm, dz=5mm

Reference Value = 26.543 V/m; Power Drift = 0.02 dB

Peak SAR (extrapolated) = 1.4530

SAR(1 g) = 0.828 mW/g; SAR(10 g) = 0.459 mW/g

Maximum value of SAR (measured) = 1.085 mW/g

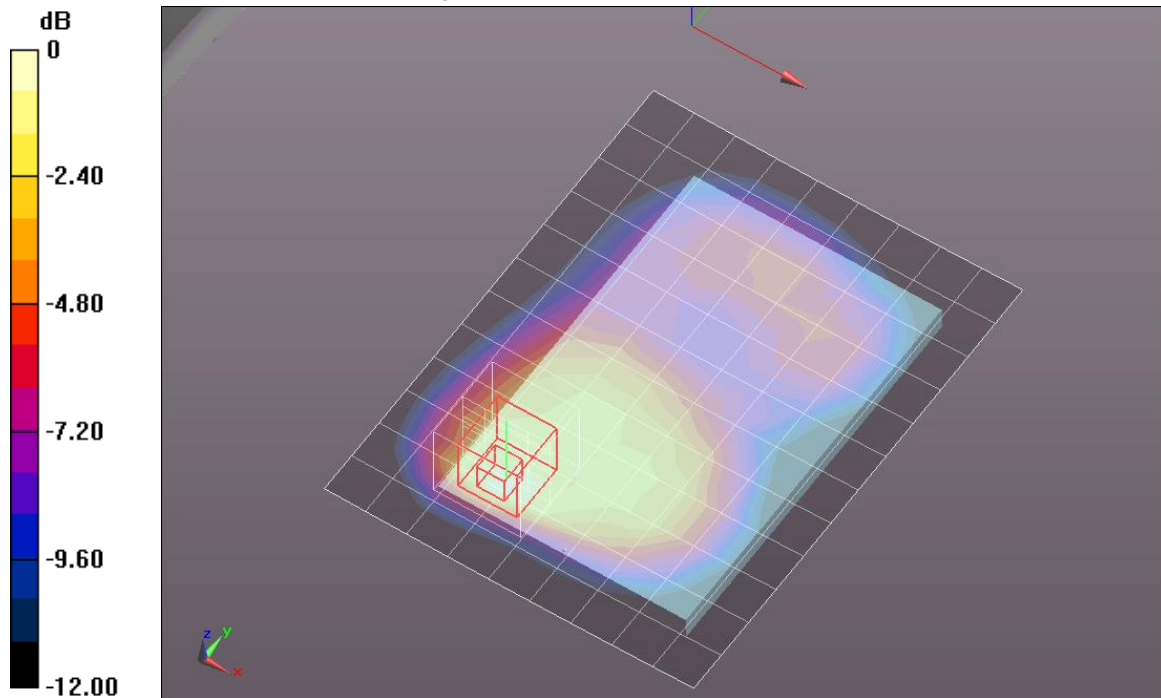

0 dB = 1.090mW/g = 0.75 dB mW/g

Test Laboratory: UL CCS SAR Lab C

Date: 4/27/2012

W-CDMA Band II

Frequency: 1880 MHz; Duty Cycle: 1:1

Rear/R99, ch 9400/Z Scan (1x1x21): Measurement grid: dx=20mm, dy=20mm, dz=5mm
Maximum value of SAR (measured) = 1.061 mW/g

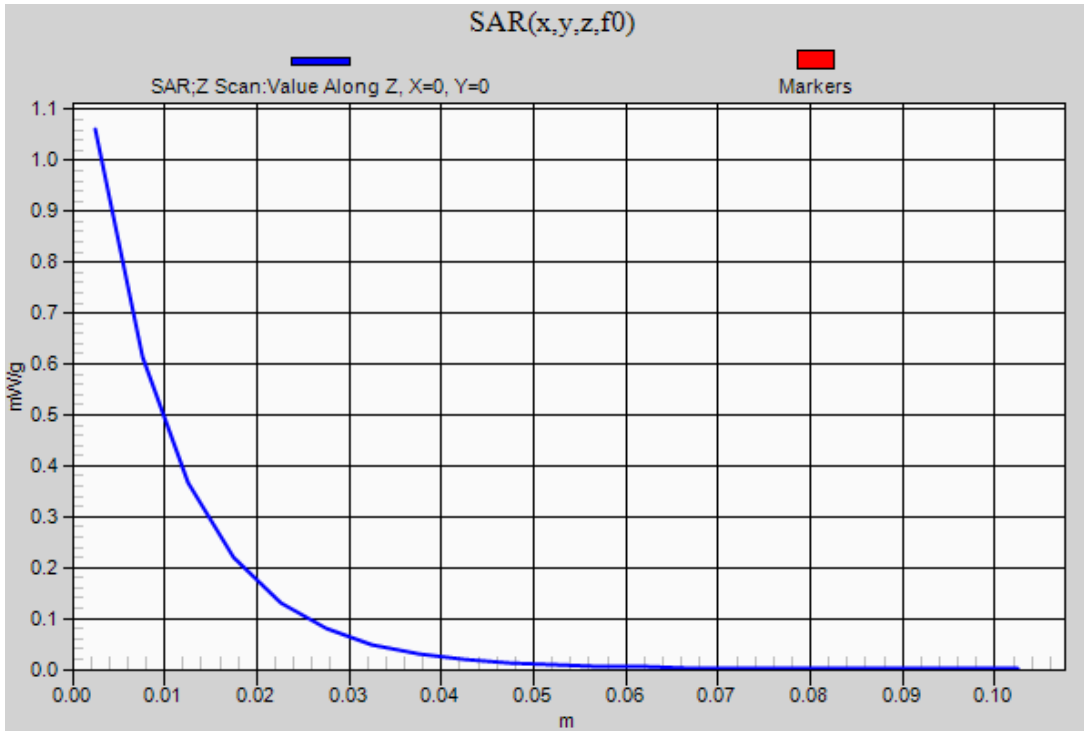

Test Laboratory: UL CCS SAR Lab C

Date: 4/28/2012

CDMA BC1

Frequency: 836.52 MHz; Duty Cycle: 1:1; Room Ambient Temperature: 24.0°C; Liquid Temperature: 23.0°C
Medium parameters used (interpolated): $f = 836.52$ MHz; $\sigma = 0.902$ mho/m; $\epsilon_r = 42.662$; $\rho = 1000$ kg/m³

DASY5 Configuration:

- Electronics: DAE3 Sn500; Calibrated: 7/14/2011
- Probe: EX3DV4 - SN3773; ConvF(8.79, 8.79, 8.79); Calibrated: 3/14/2012
- Sensor-Surface: 2.5mm (Mechanical Surface Detection (Locations From Previous Scan Used)), Sensor-Surface: 2.5mm (Mechanical Surface Detection)
- Phantom: SAM; Type: QD000P40CD; Serial: 1632

LHS/Touch_1xRTT RC3 SO55, ch 384/Area Scan (9x13x1): Measurement grid: dx=15mm, dy=15mm

[Info: Interpolated medium parameters used for SAR evaluation.](#)

Maximum value of SAR (measured) = 0.294 mW/g

LHS/Touch_1xRTT RC3 SO55, ch 384/Zoom Scan (5x5x7)/Cube 0: Measurement grid: dx=8mm, dy=8mm, dz=5mm

Reference Value = 17.866 V/m; Power Drift = -0.02 dB

Peak SAR (extrapolated) = 0.3110

SAR(1 g) = 0.261 mW/g; SAR(10 g) = 0.210 mW/g

[Info: Interpolated medium parameters used for SAR evaluation.](#)

Maximum value of SAR (measured) = 0.285 mW/g

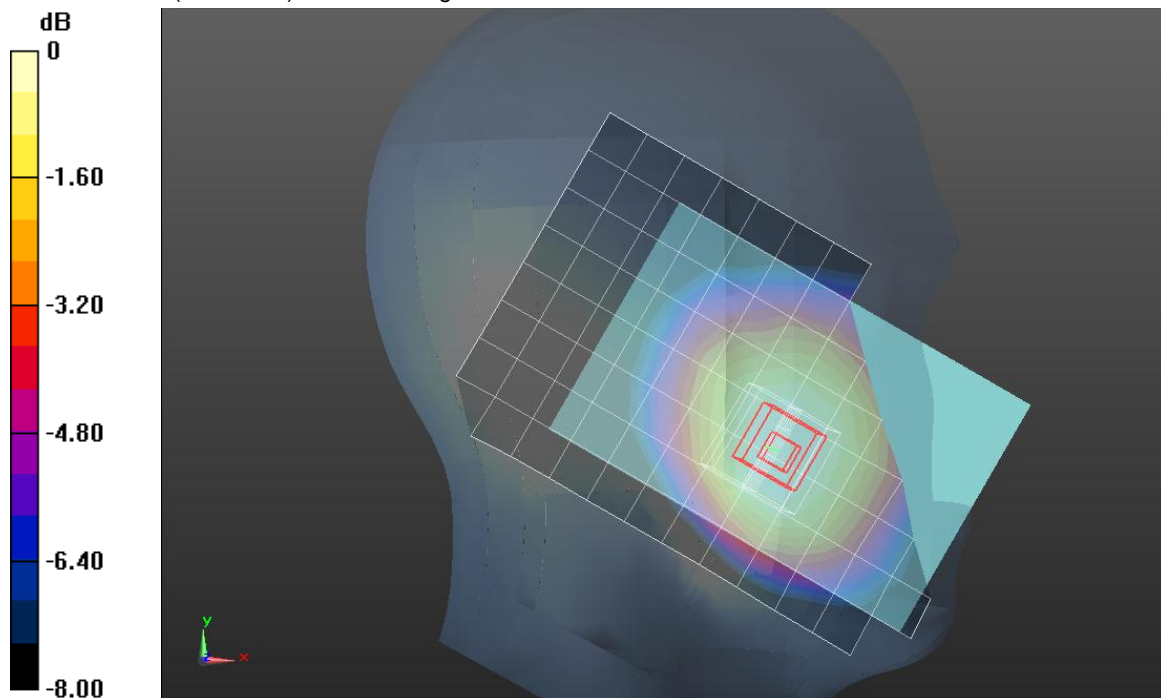

0 dB = 0.290mW/g = -10.75 dB mW/g

CDMA BC1

Frequency: 836.52 MHz; Duty Cycle: 1:1

LHS/Touch_1xRTT RC3 SO55, ch 384/Z Scan (1x1x21): Measurement grid: dx=20mm, dy=20mm, dz=5mm

Info: [Interpolated medium parameters used for SAR evaluation.](#)

Maximum value of SAR (measured) = 0.279 mW/g

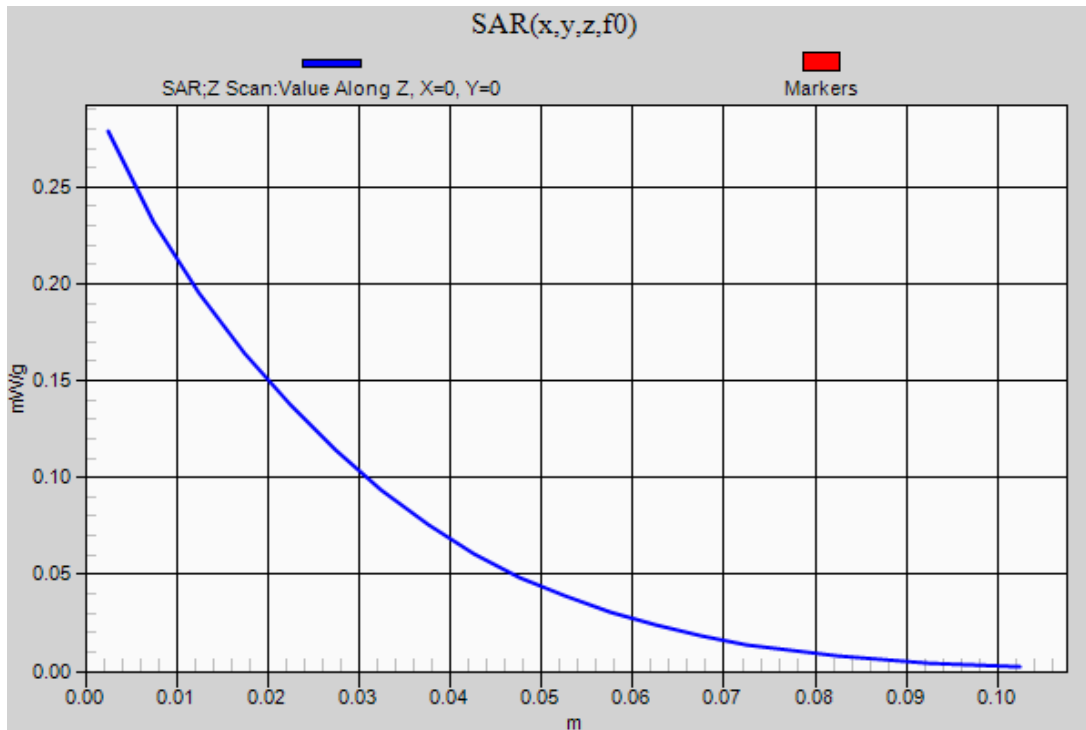

Test Laboratory: UL CCS SAR Lab C

Date: 4/29/2012

CDMA BC0

Frequency: 836.52 MHz; Duty Cycle: 1:1; Room Ambient Temperature: 24.0°C; Liquid Temperature: 23.0°C
Medium parameters used (interpolated): $f = 836.52$ MHz; $\sigma = 0.902$ mho/m; $\epsilon_r = 42.662$; $\rho = 1000$ kg/m³

DASY5 Configuration:

- Electronics: DAE3 Sn500; Calibrated: 7/14/2011
- Probe: EX3DV4 - SN3773; ConvF(8.79, 8.79, 8.79); Calibrated: 3/14/2012
- Sensor-Surface: 2.5mm (Mechanical Surface Detection (Locations From Previous Scan Used)), Sensor-Surface: 2.5mm (Mechanical Surface Detection)
- Phantom: SAM; Type: QD000P40CD; Serial: 1632

LHS/Touch_1xEVDO Rel 0, ch 384/Area Scan (9x13x1): Measurement grid: dx=15mm, dy=15mm

[Info: Interpolated medium parameters used for SAR evaluation.](#)

Maximum value of SAR (measured) = 0.444 mW/g

LHS/Touch_1xEVDO Rel 0, ch 384/Zoom Scan (5x5x7)/Cube 0: Measurement grid: dx=8mm, dy=8mm, dz=5mm

Reference Value = 22.853 V/m; Power Drift = -0.04 dB

Peak SAR (extrapolated) = 0.7000

SAR(1 g) = 0.332 mW/g; SAR(10 g) = 0.208 mW/g

[Info: Interpolated medium parameters used for SAR evaluation.](#)

Maximum value of SAR (measured) = 0.458 mW/g

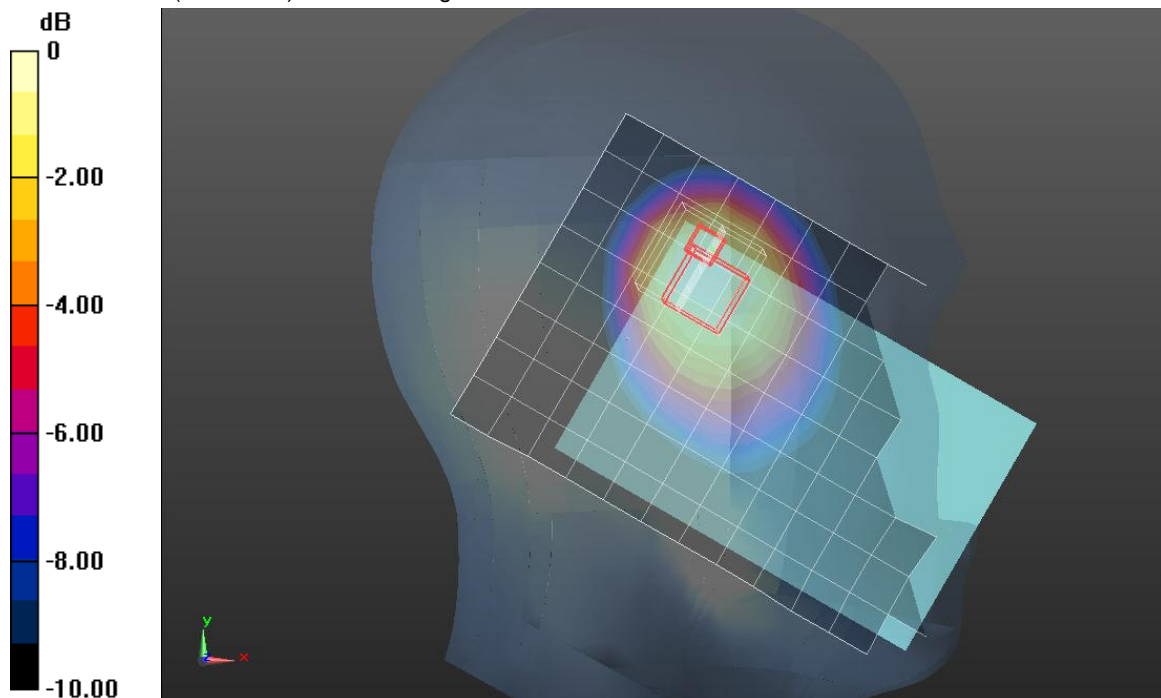

0 dB = 0.460mW/g = -6.74 dB mW/g

Test Laboratory: UL CCS SAR Lab C

Date: 4/29/2012

CDMA BC0

Frequency: 836.52 MHz; Duty Cycle: 1:1

LHS/Touch_1xEVDO Rel 0, ch 384/Z Scan (1x1x21): Measurement grid: dx=20mm, dy=20mm, dz=5mm

Info: [Interpolated medium parameters used for SAR evaluation.](#)

Maximum value of SAR (measured) = 0.457 mW/g

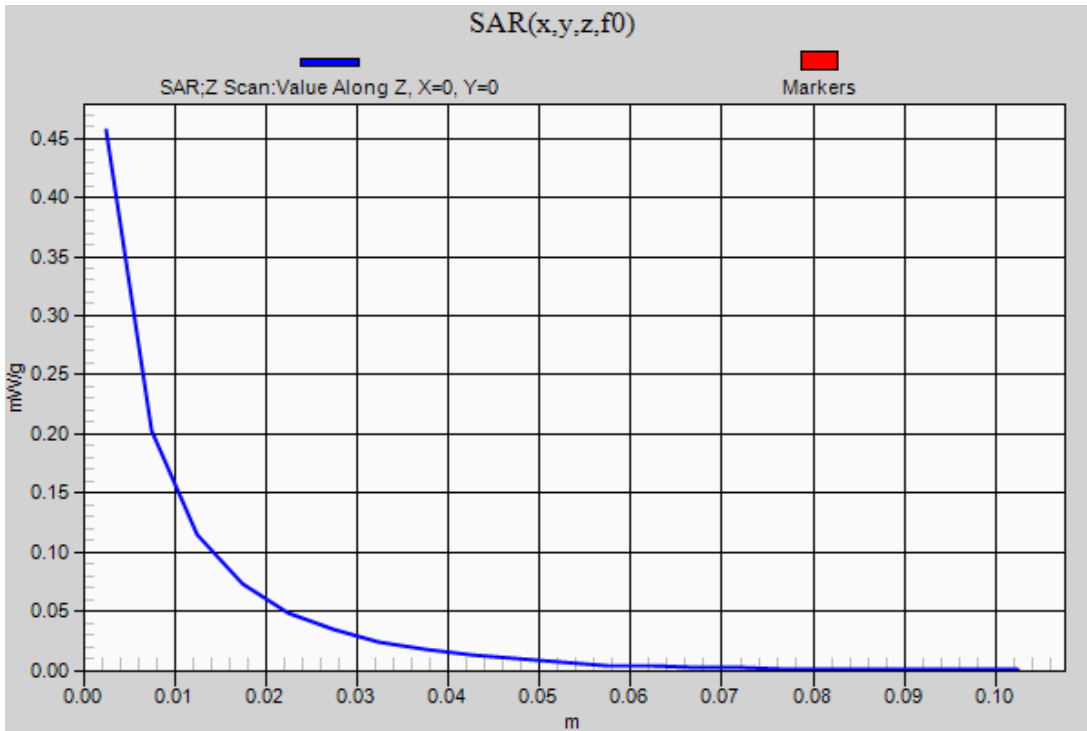

Test Laboratory: UL CCS SAR Lab C

Date: 4/30/2012

CDMA BC0

Frequency: 848.31 MHz; Duty Cycle: 1:1; Room Ambient Temperature: 24.0°C; Liquid Temperature: 23.0°C
Medium parameters used (interpolated): $f = 848.31$ MHz; $\sigma = 1.025$ mho/m; $\epsilon_r = 53.697$; $\rho = 1000$ kg/m³

DASY5 Configuration:

- Electronics: DAE3 Sn500; Calibrated: 7/14/2011
- Probe: EX3DV4 - SN3773; ConvF(8.74, 8.74, 8.74); Calibrated: 3/14/2012
- Sensor-Surface: 2.5mm (Mechanical Surface Detection (Locations From Previous Scan Used)), Sensor-Surface: 2.5mm (Mechanical Surface Detection)
- Phantom: ELI v5.0 (A); Type: QDOVA001BB; Serial: 1120

Rear/1xRTT RC3 SO32, ch 777 w/headset/Area Scan (10x13x1): Measurement grid: dx=15mm, dy=15mm

Info: [Interpolated medium parameters used for SAR evaluation.](#)

Maximum value of SAR (measured) = 1.142 mW/g

Rear/1xRTT RC3 SO32, ch 777 w/headset/Zoom Scan (5x5x7)/Cube 0: Measurement grid:

dx=8mm, dy=8mm, dz=5mm

Reference Value = 34.049 V/m; Power Drift = -0.0011 dB

Peak SAR (extrapolated) = 1.4690

SAR(1 g) = 0.894 mW/g; SAR(10 g) = 0.542 mW/g

Info: [Interpolated medium parameters used for SAR evaluation.](#)

Maximum value of SAR (measured) = 1.054 mW/g

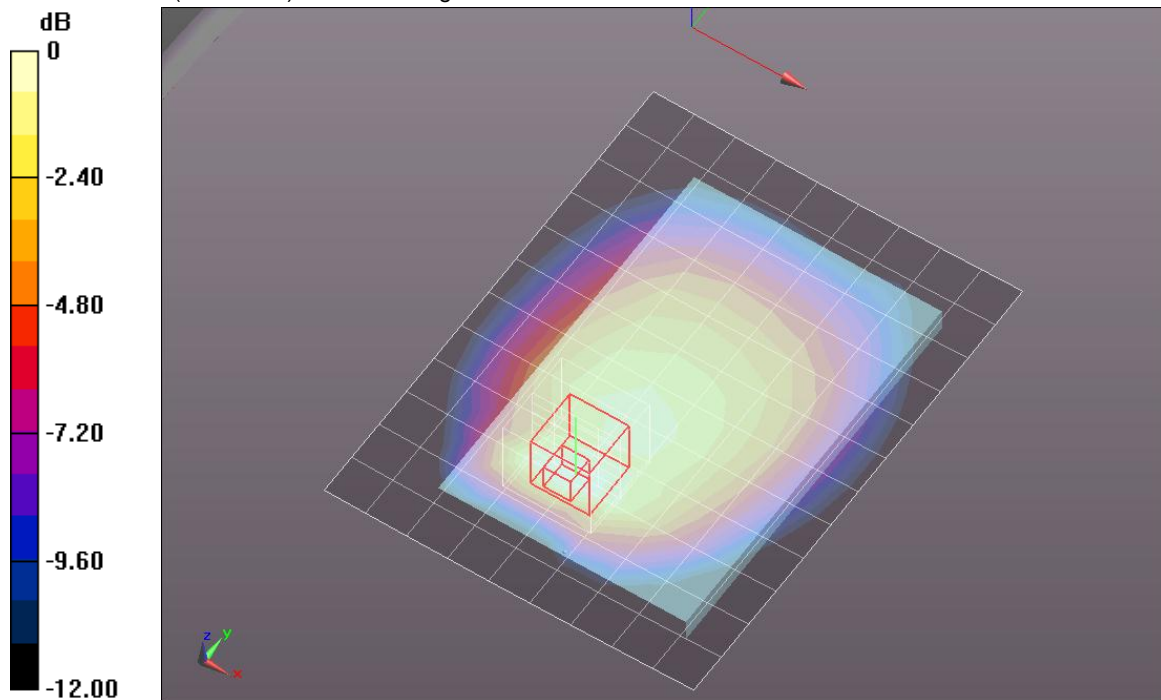

0 dB = 1.050mW/g = 0.42 dB mW/g

CDMA BC0

Frequency: 848.31 MHz; Duty Cycle: 1:1

Rear/1xRTT RC3 SO32, ch 777 w/headset/Z Scan (1x1x21): Measurement grid: dx=20mm, dy=20mm, dz=5mm

Info: [Interpolated medium parameters used for SAR evaluation.](#)

Maximum value of SAR (measured) = 1.149 mW/g

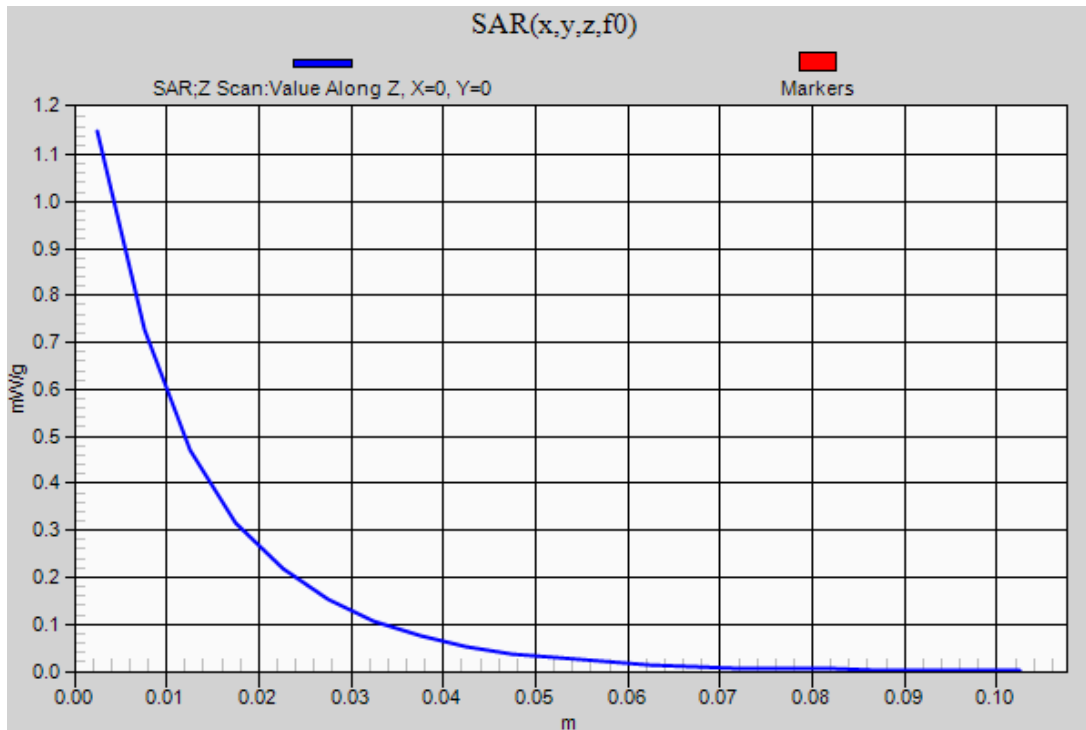

Test Laboratory: UL CCS SAR Lab C

Date: 5/1/2012

CDMA BC0

Frequency: 836.52 MHz; Duty Cycle: 1:1; Room Ambient Temperature: 24.0°C; Liquid Temperature: 23.0°C
Medium parameters used (interpolated): $f = 836.52$ MHz; $\sigma = 1.013$ mho/m; $\epsilon_r = 53.814$; $\rho = 1000$ kg/m³

DASY5 Configuration:

- Electronics: DAE3 Sn500; Calibrated: 7/14/2011
- Probe: EX3DV4 - SN3773; ConvF(8.74, 8.74, 8.74); Calibrated: 3/14/2012
- Sensor-Surface: 2.5mm (Mechanical Surface Detection (Locations From Previous Scan Used)), Sensor-Surface: 2.5mm (Mechanical Surface Detection)
- Phantom: ELI v5.0 (A); Type: QDOVA001BB; Serial: 1120

Rear/1xEVDO Rel 0, ch 384/Area Scan (10x13x1): Measurement grid: dx=15mm, dy=15mm

[Info: Interpolated medium parameters used for SAR evaluation.](#)

Maximum value of SAR (measured) = 0.596 mW/g

Rear/1xEVDO Rel 0, ch 384/Zoom Scan (5x5x7)/Cube 0: Measurement grid: dx=8mm, dy=8mm, dz=5mm

Reference Value = 24.646 V/m; Power Drift = -0.02 dB

Peak SAR (extrapolated) = 0.8860

SAR(1 g) = 0.493 mW/g; SAR(10 g) = 0.281 mW/g

[Info: Interpolated medium parameters used for SAR evaluation.](#)

Maximum value of SAR (measured) = 0.633 mW/g

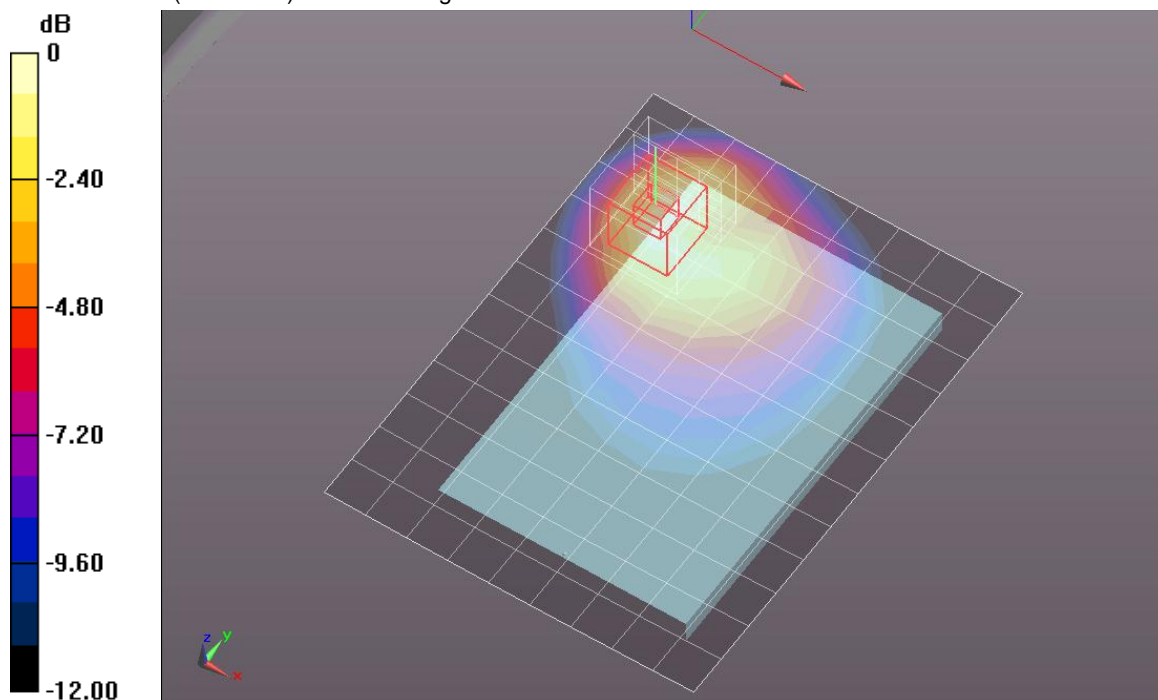

0 dB = 0.630mW/g = -4.01 dB mW/g

CDMA BC0

Frequency: 836.52 MHz; Duty Cycle: 1:1

Rear/1xEVDO Rel 0, ch 384/Z Scan (1x1x21): Measurement grid: dx=20mm, dy=20mm, dz=5mm

Info: [Interpolated medium parameters used for SAR evaluation.](#)

Maximum value of SAR (measured) = 0.588 mW/g

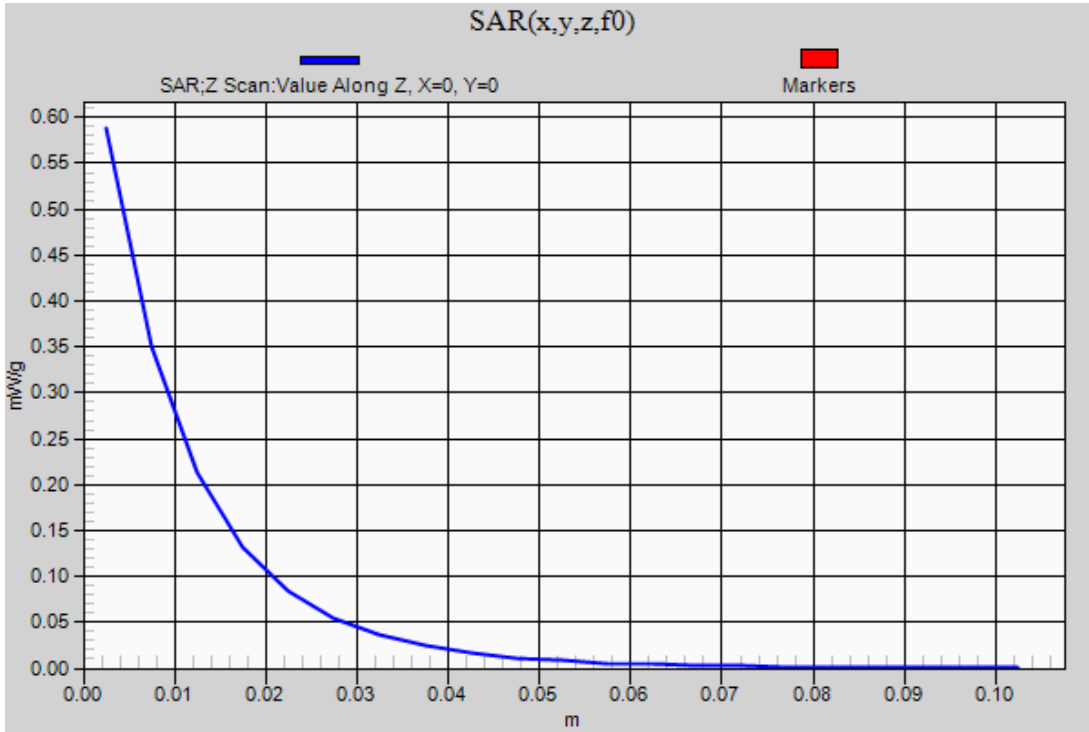

Test Laboratory: UL CCS SAR Lab C

Date: 4/27/2012

CDMA BC1

Frequency: 1880 MHz; Duty Cycle: 1:1; Room Ambient Temperature: 24.0°C; Liquid Temperature: 23.0°C
Medium parameters used: $f = 1880$ MHz; $\sigma = 1.425$ mho/m; $\epsilon_r = 41.279$; $\rho = 1000$ kg/m³

DASY5 Configuration:

- Electronics: DAE3 Sn500; Calibrated: 7/14/2011
- Probe: EX3DV4 - SN3773; ConvF(7.51, 7.51, 7.51); Calibrated: 3/14/2012
- Sensor-Surface: 2.5mm (Mechanical Surface Detection (Locations From Previous Scan Used)), Sensor-Surface: 2.5mm (Mechanical Surface Detection)
- Phantom: SAM; Type: QD000P40CD; Serial: 1632

RHS/Touch_1xRTT RC3 SO55, ch 600/Area Scan (9x13x1): Measurement grid: dx=15mm, dy=15mm
Maximum value of SAR (measured) = 0.919 mW/g

RHS/Touch_1xRTT RC3 SO55, ch 600/Zoom Scan (5x5x7)/Cube 0: Measurement grid: dx=8mm, dy=8mm, dz=5mm
Reference Value = 25.720 V/m; Power Drift = 0.00011 dB
Peak SAR (extrapolated) = 1.1370
SAR(1 g) = 0.801 mW/g; SAR(10 g) = 0.517 mW/g
Maximum value of SAR (measured) = 0.932 mW/g

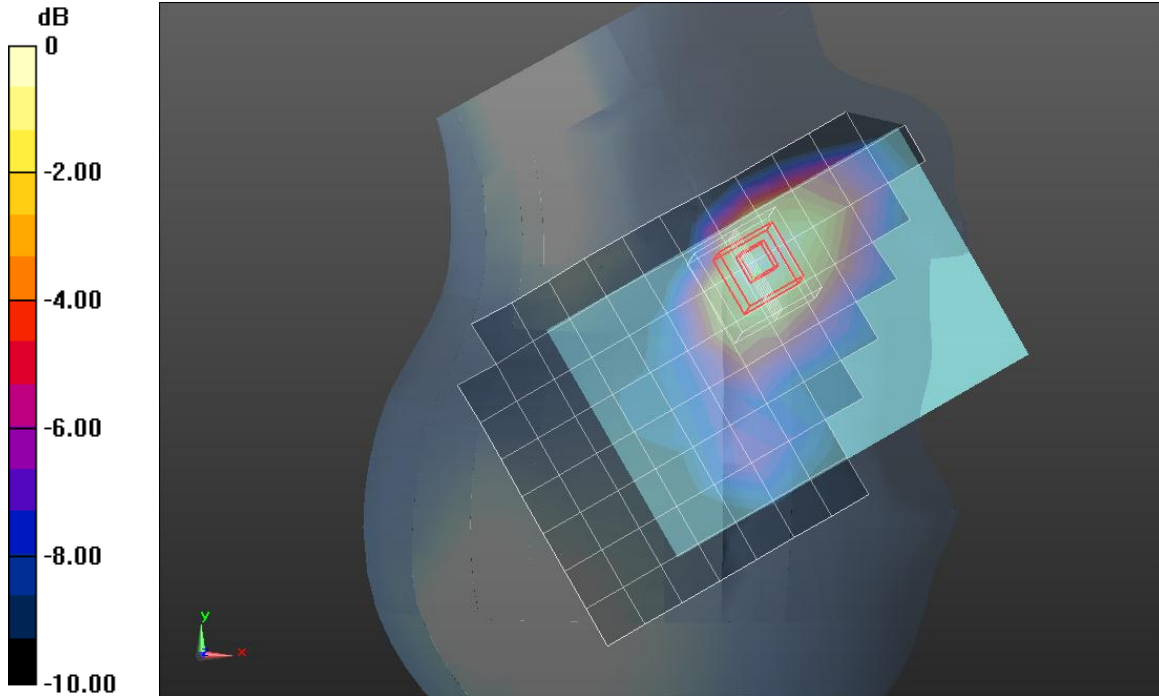

0 dB = 0.930mW/g = -0.63 dB mW/g

CDMA BC1

Frequency: 1880 MHz; Duty Cycle: 1:1

RHS/Touch_1xRTT RC3 SO55, ch 600/Z Scan (1x1x21): Measurement grid: dx=20mm, dy=20mm, dz=5mm

Maximum value of SAR (measured) = 0.911 mW/g

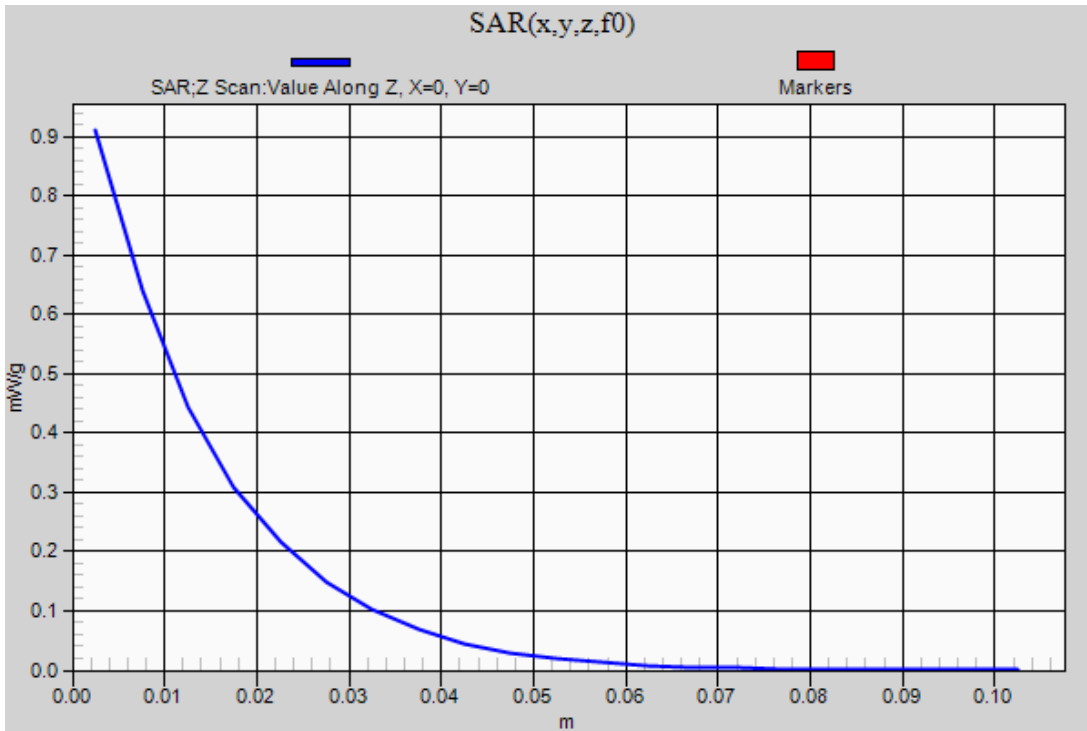

Test Laboratory: UL CCS SAR Lab C

Date: 4/27/2012

CDMA BC1

Frequency: 1880 MHz; Duty Cycle: 1:1; Room Ambient Temperature: 24.0°C; Liquid Temperature: 23.0°C

Medium parameters used: $f = 1880$ MHz; $\sigma = 1.425$ mho/m; $\epsilon_r = 41.279$; $\rho = 1000$ kg/m³

DASY5 Configuration:

- Electronics: DAE3 Sn500; Calibrated: 7/14/2011

- Probe: EX3DV4 - SN3773; ConvF(7.51, 7.51, 7.51); Calibrated: 3/14/2012

- Sensor-Surface: 2.5mm (Mechanical Surface Detection (Locations From Previous Scan Used)), Sensor-Surface: 2.5mm (Mechanical Surface Detection)

- Phantom: SAM; Type: QD000P40CD; Serial: 1632

LHS/Touch_1xEVDO Rel 0, ch 600/Area Scan (9x13x1): Measurement grid: dx=15mm, dy=15mm

Maximum value of SAR (measured) = 0.726 mW/g

LHS/Touch_1xEVDO Rel 0, ch 600/Zoom Scan (5x5x7)/Cube 0: Measurement grid: dx=8mm,

dy=8mm, dz=5mm

Reference Value = 22.719 V/m; Power Drift = 0.10 dB

Peak SAR (extrapolated) = 1.2240

SAR(1 g) = 0.613 mW/g; SAR(10 g) = 0.292 mW/g

Maximum value of SAR (measured) = 0.782 mW/g

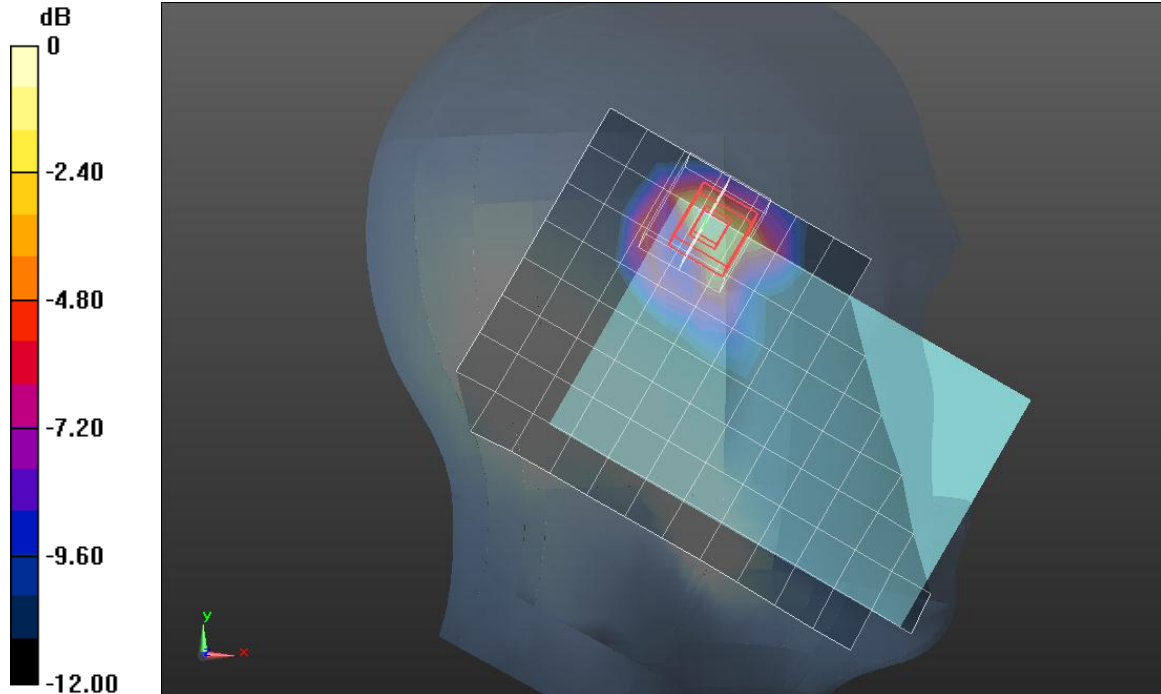

0 dB = 0.780mW/g = -2.16 dB mW/g

Test Laboratory: UL CCS SAR Lab C

Date: 4/27/2012

CDMA BC1

Frequency: 1880 MHz; Duty Cycle: 1:1

LHS/Touch_1xEVDO Rel 0, ch 600/Z Scan (1x1x21): Measurement grid: dx=20mm, dy=20mm, dz=5mm
Maximum value of SAR (measured) = 0.732 mW/g

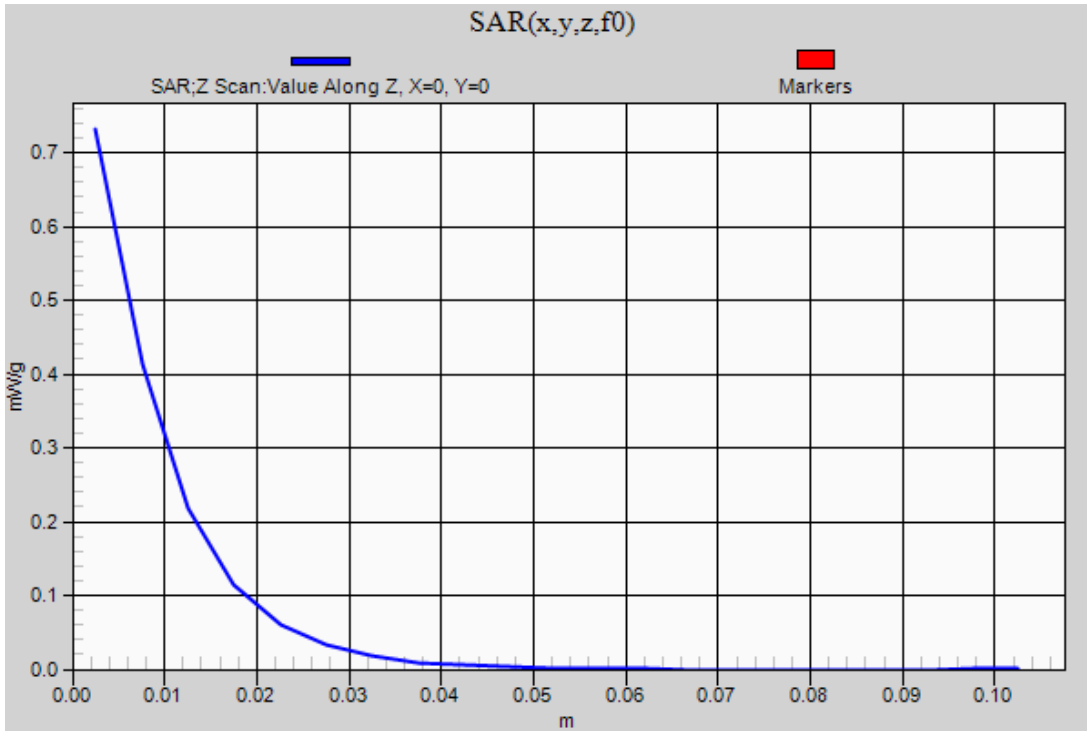

Test Laboratory: UL CCS SAR Lab C

Date: 4/26/2012

CDMA BC1

Frequency: 1851.25 MHz; Duty Cycle: 1:1; Room Ambient Temperature: 24.0°C; Liquid Temperature: 23.0°C
Medium parameters used (interpolated): $f = 1851.25$ MHz; $\sigma = 1.464$ mho/m; $\epsilon_r = 53.107$; $\rho = 1000$ kg/m³

DASY5 Configuration:

- Electronics: DAE3 Sn500; Calibrated: 7/14/2011
- Probe: EX3DV4 - SN3773; ConvF(7.11, 7.11, 7.11); Calibrated: 3/14/2012
- Sensor-Surface: 2.5mm (Mechanical Surface Detection (Locations From Previous Scan Used)), Sensor-Surface: 2.5mm (Mechanical Surface Detection)
- Phantom: ELI v5.0 (A); Type: QDOVA001BB; Serial: 1120

Rear/1xRTT RC3 SO55, ch 25/Area Scan (10x13x1): Measurement grid: dx=15mm, dy=15mm

[Info: Interpolated medium parameters used for SAR evaluation.](#)

Maximum value of SAR (measured) = 1.696 mW/g

Rear/1xRTT RC3 SO55, ch 25/Zoom Scan (5x5x7)/Cube 0: Measurement grid: dx=8mm, dy=8mm, dz=5mm

Reference Value = 33.308 V/m; Power Drift = 0.13 dB

Peak SAR (extrapolated) = 2.1720

SAR(1 g) = 1.24 mW/g; SAR(10 g) = 0.699 mW/g

[Info: Interpolated medium parameters used for SAR evaluation.](#)

Maximum value of SAR (measured) = 1.552 mW/g

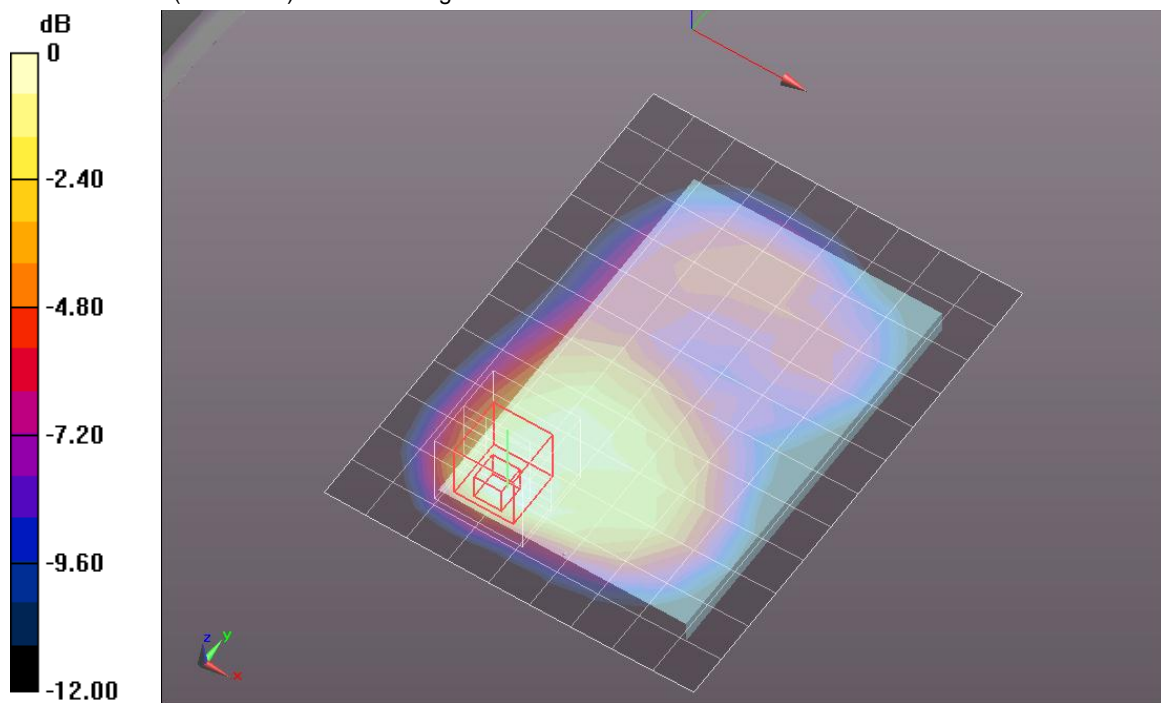

0 dB = 1.550mW/g = 3.81 dB mW/g

CDMA BC1

Frequency: 1851.25 MHz; Duty Cycle: 1:1

Rear/1xRTT RC3 SO55, ch 25/Z Scan (1x1x21): Measurement grid: dx=20mm, dy=20mm, dz=5mm

Info: [Interpolated medium parameters used for SAR evaluation.](#)

Maximum value of SAR (measured) = 1.642 mW/g

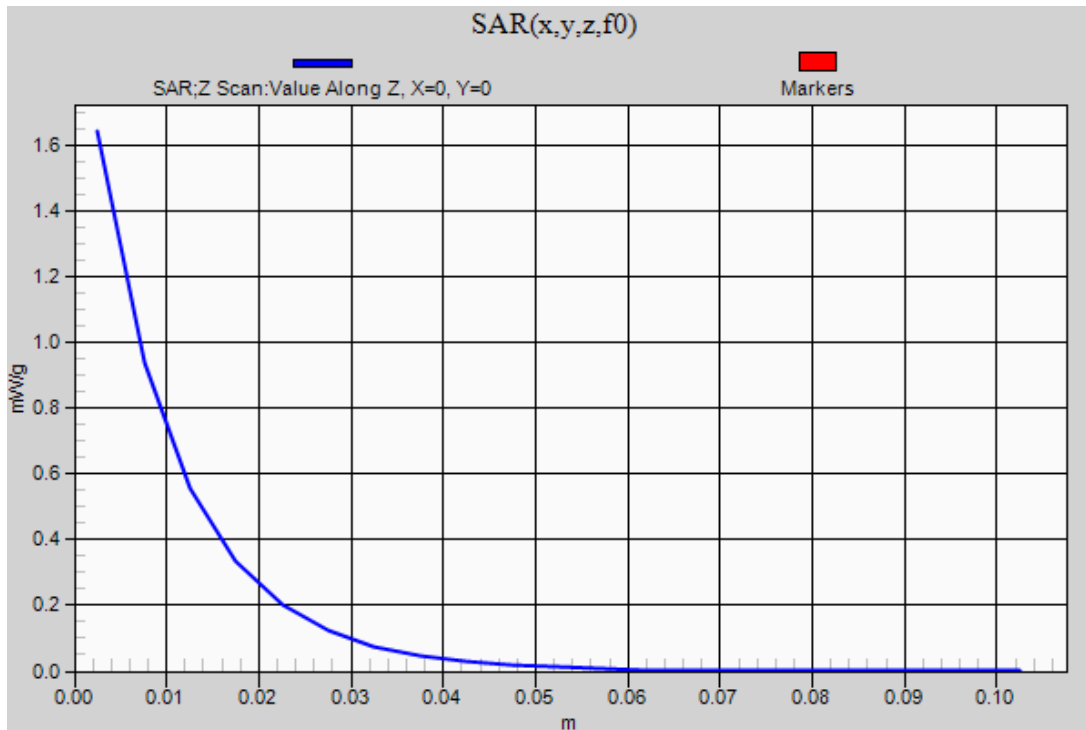

Test Laboratory: UL CCS SAR Lab C

Date: 4/27/2012

CDMA BC1

Frequency: 1880 MHz; Duty Cycle: 1:1; Room Ambient Temperature: 24.0°C; Liquid Temperature: 23.0°C
Medium parameters used: $f = 1880$ MHz; $\sigma = 1.496$ mho/m; $\epsilon_r = 53.011$; $\rho = 1000$ kg/m³

DASY5 Configuration:

- Electronics: DAE3 Sn500; Calibrated: 7/14/2011
- Probe: EX3DV4 - SN3773; ConvF(7.11, 7.11, 7.11); Calibrated: 3/14/2012
- Sensor-Surface: 2.5mm (Mechanical Surface Detection (Locations From Previous Scan Used)), Sensor-Surface: 2.5mm (Mechanical Surface Detection)
- Phantom: ELI v5.0 (A); Type: QDOVA001BB; Serial: 1120

Rear/1xEVDO Rel 0, ch 600/Area Scan (10x13x1): Measurement grid: dx=15mm, dy=15mm
Maximum value of SAR (measured) = 1.320 mW/g

Rear/1xEVDO Rel 0, ch 600/Zoom Scan (5x5x7)/Cube 0: Measurement grid: dx=8mm, dy=8mm, dz=5mm
Reference Value = 30.119 V/m; Power Drift = -0.14 dB
Peak SAR (extrapolated) = 1.7970
SAR(1 g) = 1.03 mW/g; SAR(10 g) = 0.532 mW/g
Maximum value of SAR (measured) = 1.338 mW/g

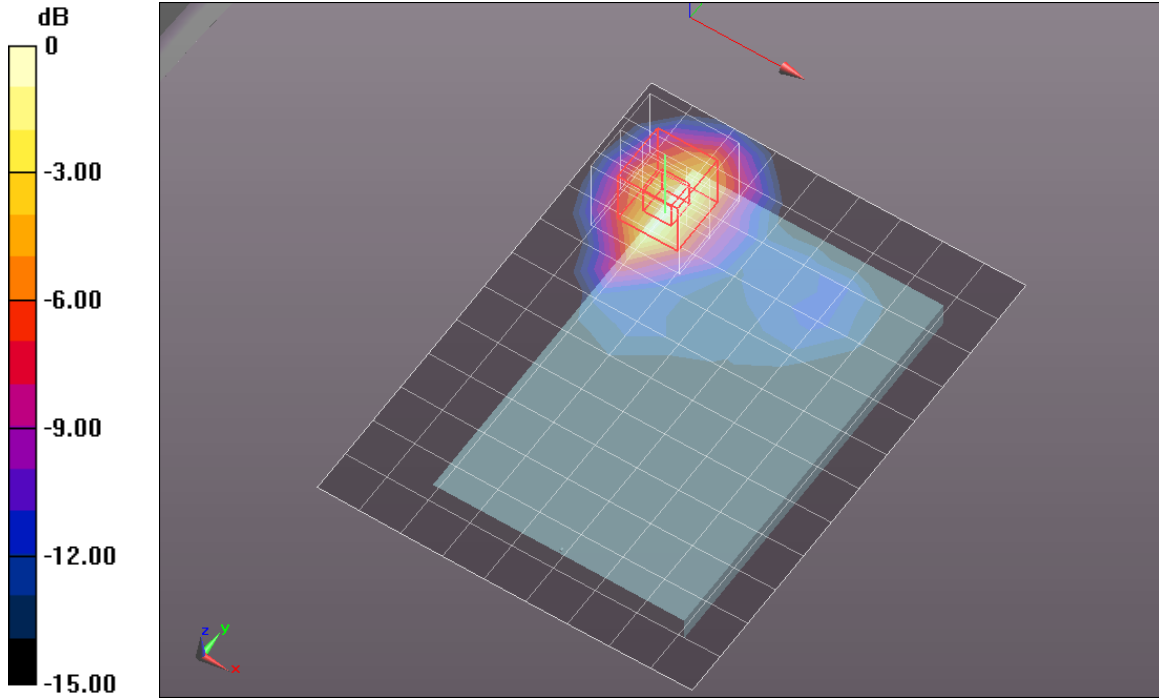

0 dB = 1.340mW/g = 2.54 dB mW/g

CDMA BC1

Frequency: 1880 MHz; Duty Cycle: 1:1

Rear/1xEVDO Rel 0, ch 600/Z Scan (1x1x21): Measurement grid: dx=20mm, dy=20mm, dz=5mm
Maximum value of SAR (measured) = 1.289 mW/g

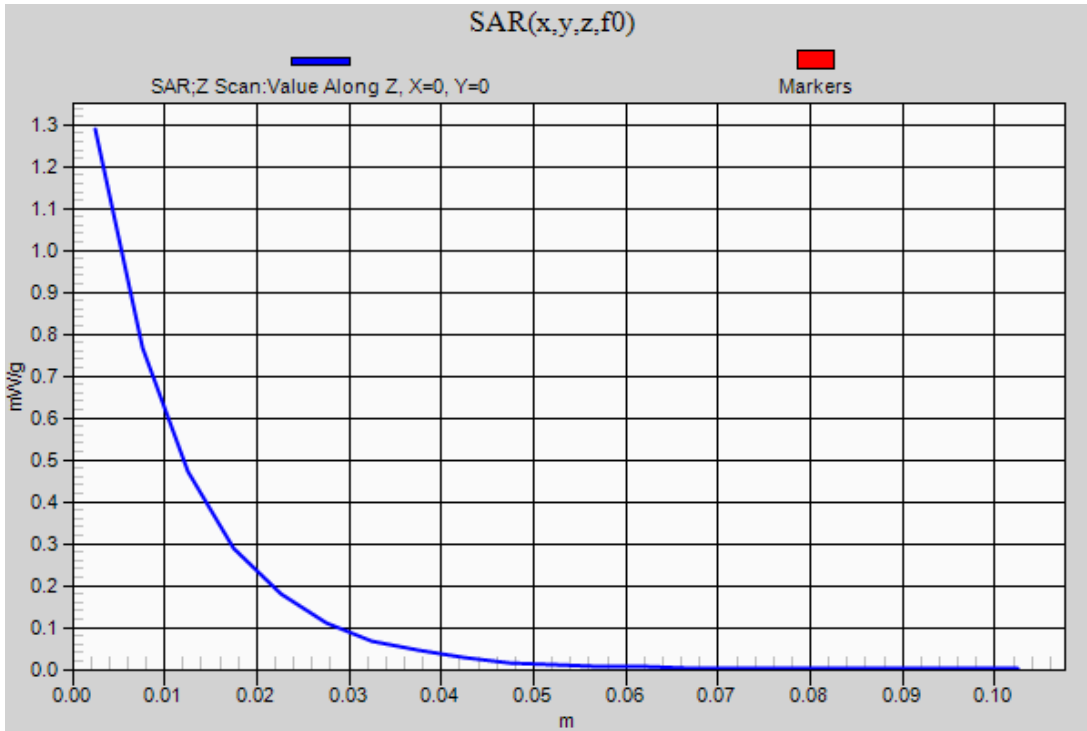

Test Laboratory: UL CCS SAR Lab C

Date: 5/2/2012

LTE Band 13

Frequency: 782 MHz; Duty Cycle: 1:1; Room Ambient Temperature: 24.0°C; Liquid Temperature: 23.0°C
Medium parameters used (interpolated): $f = 782 \text{ MHz}$; $\sigma = 0.919 \text{ mho/m}$; $\epsilon_r = 41.293$; $\rho = 1000 \text{ kg/m}^3$

DASY5 Configuration:

- Electronics: DAE3 Sn500; Calibrated: 7/14/2011
- Probe: EX3DV4 - SN3773; ConvF(9.16, 9.16, 9.16); Calibrated: 3/14/2012
- Sensor-Surface: 2.5mm (Mechanical Surface Detection (Locations From Previous Scan Used)), Sensor-Surface: 2.5mm (Mechanical Surface Detection)
- Phantom: SAM; Type: QD000P40CD; Serial: 1632

LHS/Touch_10MHz QPSK_RB1/49_Ch M/Area Scan (9x13x1): Measurement grid: dx=15mm, dy=15mm

Info: [Interpolated medium parameters used for SAR evaluation.](#)

Maximum value of SAR (measured) = 0.148 mW/g

LHS/Touch_10MHz QPSK_RB1/49_Ch M/Zoom Scan (5x5x7)/Cube 0: Measurement grid: dx=8mm, dy=8mm, dz=5mm

Reference Value = 12.722 V/m; Power Drift = 0.11 dB

Peak SAR (extrapolated) = 0.1660

SAR(1 g) = 0.134 mW/g; SAR(10 g) = 0.103 mW/g

Info: [Interpolated medium parameters used for SAR evaluation.](#)

Maximum value of SAR (measured) = 0.149 mW/g

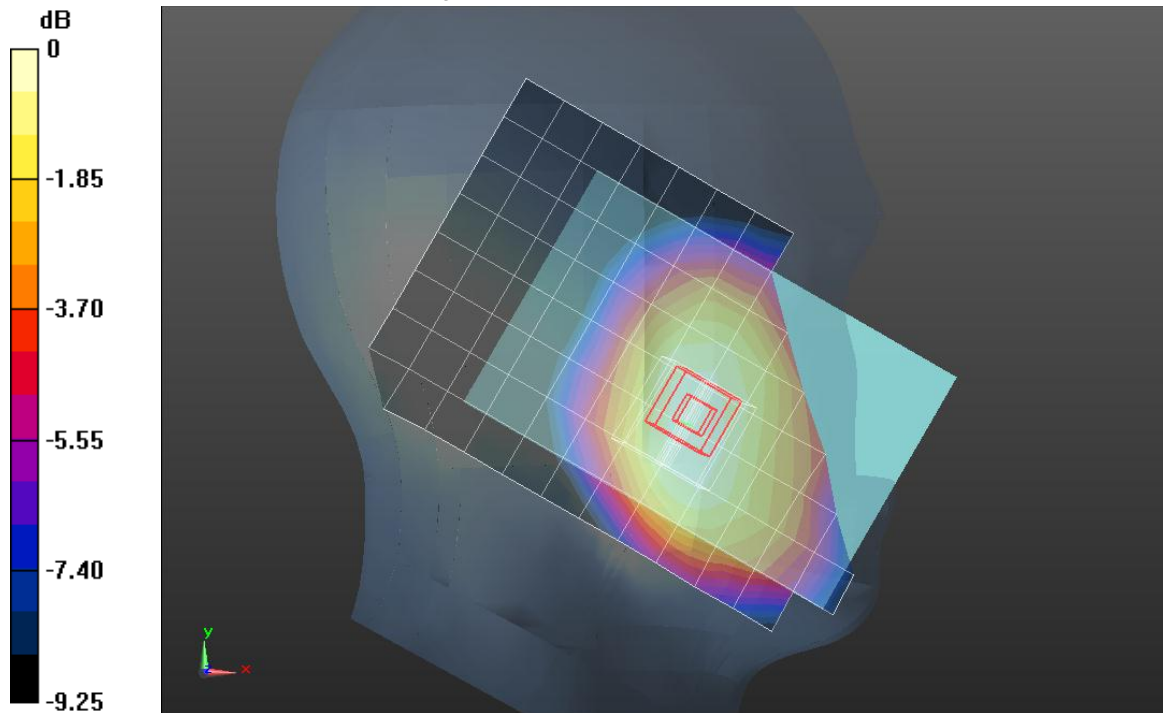

0 dB = 0.150mW/g = -16.48 dB mW/g

LTE Band 13

Frequency: 782 MHz; Duty Cycle: 1:1

LHS/Touch_10MHz QPSK_RB1/49_Ch M/Z Scan (1x1x21): Measurement grid: dx=20mm, dy=20mm, dz=5mm

Info: [Interpolated medium parameters used for SAR evaluation.](#)

Maximum value of SAR (measured) = 0.150 mW/g

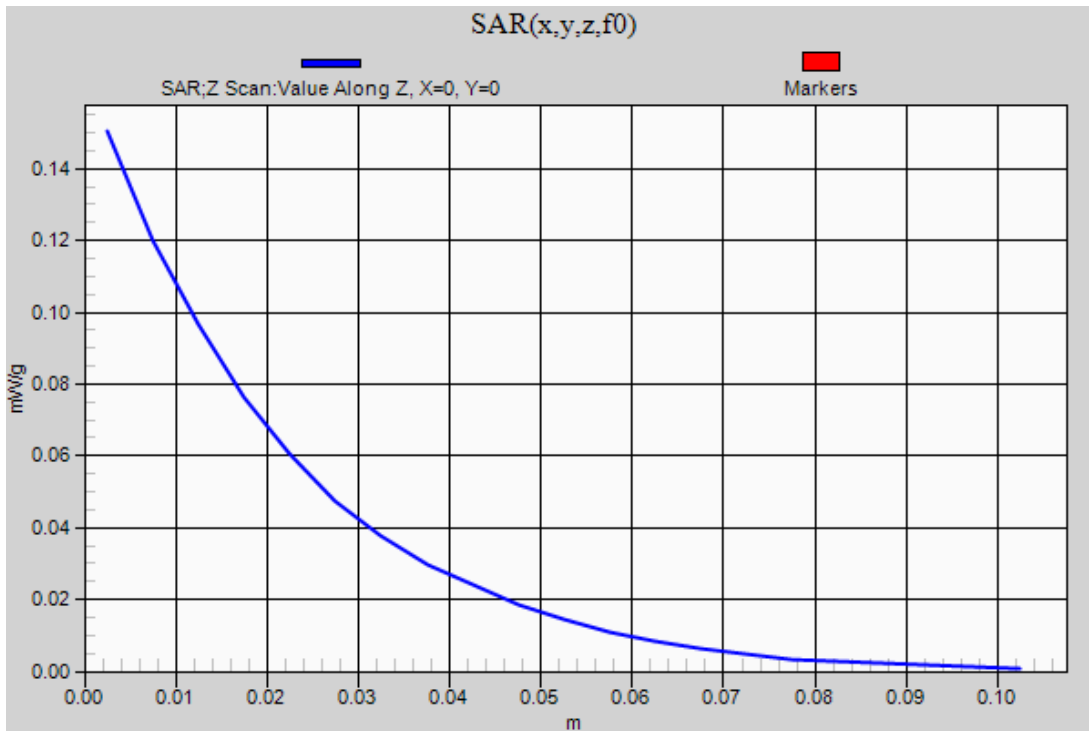

Test Laboratory: UL CCS SAR Lab C

Date: 5/2/2012

LTE Band 13

Frequency: 782 MHz; Duty Cycle: 1:1; Room Ambient Temperature: 24.0°C; Liquid Temperature: 23.0°C
Medium parameters used (interpolated): $f = 782 \text{ MHz}$; $\sigma = 0.993 \text{ mho/m}$; $\epsilon_r = 56.164$; $\rho = 1000 \text{ kg/m}^3$

DASY5 Configuration:

- Electronics: DAE3 Sn500; Calibrated: 7/14/2011
- Probe: EX3DV4 - SN3773; ConvF(8.92, 8.92, 8.92); Calibrated: 3/14/2012
- Sensor-Surface: 2.5mm (Mechanical Surface Detection (Locations From Previous Scan Used)), Sensor-Surface: 2.5mm (Mechanical Surface Detection)
- Phantom: ELI v5.0 (A); Type: QDOVA001BB; Serial: 1120

Rear/10MHz QPSK_RB1/49_Ch M/Area Scan (10x13x1): Measurement grid: $dx=15\text{mm}$, $dy=15\text{mm}$

[Info: Interpolated medium parameters used for SAR evaluation.](#)

Maximum value of SAR (measured) = 0.710 mW/g

Rear/10MHz QPSK_RB1/49_Ch M/Zoom Scan (5x5x7)/Cube 0: Measurement grid: $dx=8\text{mm}$, $dy=8\text{mm}$, $dz=5\text{mm}$

Reference Value = 27.191 V/m; Power Drift = -0.05 dB

Peak SAR (extrapolated) = 0.9790

SAR(1 g) = 0.576 mW/g; SAR(10 g) = 0.348 mW/g

[Info: Interpolated medium parameters used for SAR evaluation.](#)

Maximum value of SAR (measured) = 0.712 mW/g

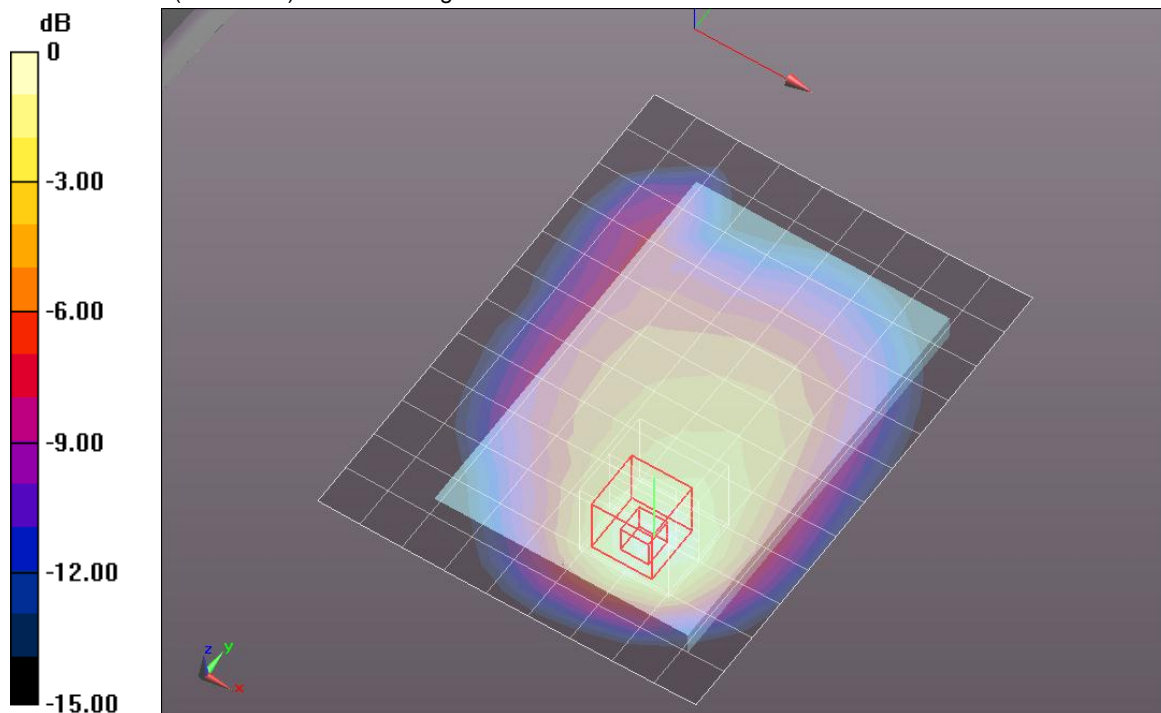

0 dB = 0.710mW/g = -2.97 dB mW/g

Test Laboratory: UL CCS SAR Lab C

Date: 5/2/2012

LTE Band 13

Frequency: 782 MHz; Duty Cycle: 1:1

Rear/10MHz QPSK_RB1/49_Ch M/Z Scan (1x1x21): Measurement grid: dx=20mm, dy=20mm, dz=5mm

Info: [Interpolated medium parameters used for SAR evaluation.](#)

Maximum value of SAR (measured) = 0.713 mW/g

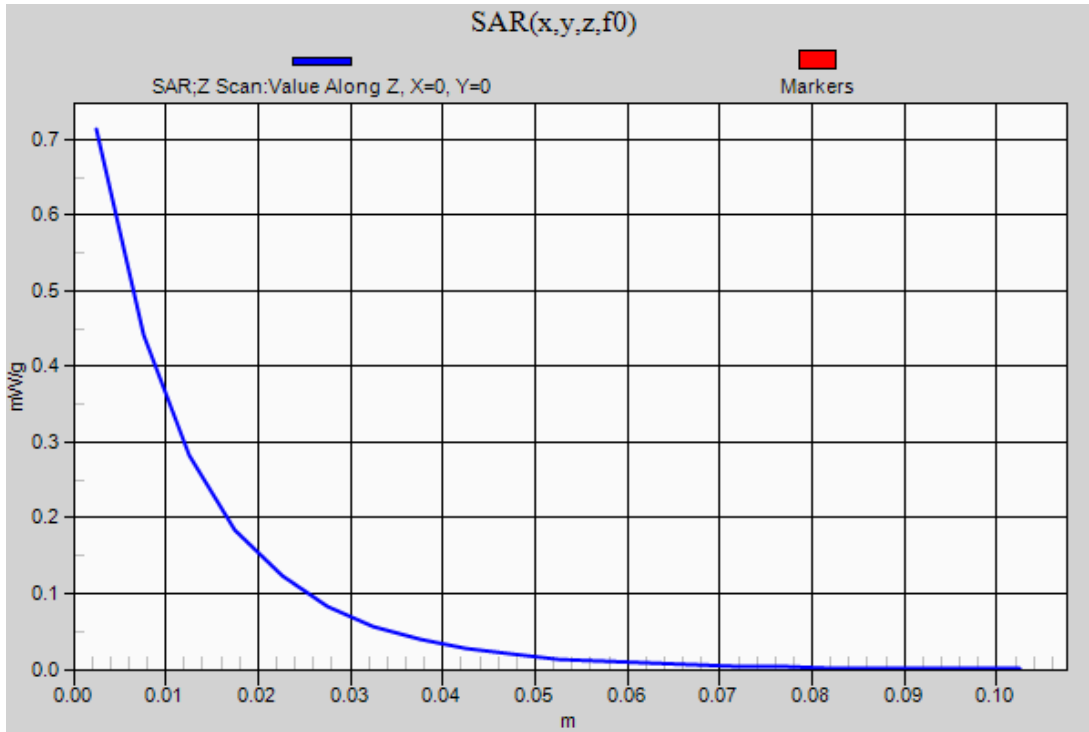

Test Laboratory: UL CCS SAR Lab C

Date: 5/1/2012

WiFi 2.4GHz

Frequency: 2462 MHz; Duty Cycle: 1:1; Room Ambient Temperature: 24.0°C; Liquid Temperature: 23.0°C
Medium parameters used (interpolated): $f = 2462$ MHz; $\sigma = 1.796$ mho/m; $\epsilon_r = 39.194$; $\rho = 1000$ kg/m³

DASY5 Configuration:

- Electronics: DAE3 Sn500; Calibrated: 7/14/2011
- Probe: EX3DV4 - SN3773; ConvF(6.67, 6.67, 6.67); Calibrated: 3/14/2012
- Sensor-Surface: 2.5mm (Mechanical Surface Detection)
- Phantom: SAM; Type: QD000P40CD; Serial: 1632

RHS/Touch, ch 11/Area Scan (8x13x1): Measurement grid: dx=15mm, dy=15mm

[Info: Interpolated medium parameters used for SAR evaluation.](#)

Maximum value of SAR (measured) = 0.184 mW/g

RHS/Touch, ch 11/Zoom Scan (5x5x7)/Cube 0: Measurement grid: dx=8mm, dy=8mm, dz=5mm

Reference Value = 8.985 V/m; Power Drift = 0.13 dB

Peak SAR (extrapolated) = 0.3130

SAR(1 g) = 0.151 mW/g; SAR(10 g) = 0.068 mW/g

[Info: Interpolated medium parameters used for SAR evaluation.](#)

Maximum value of SAR (measured) = 0.196 mW/g

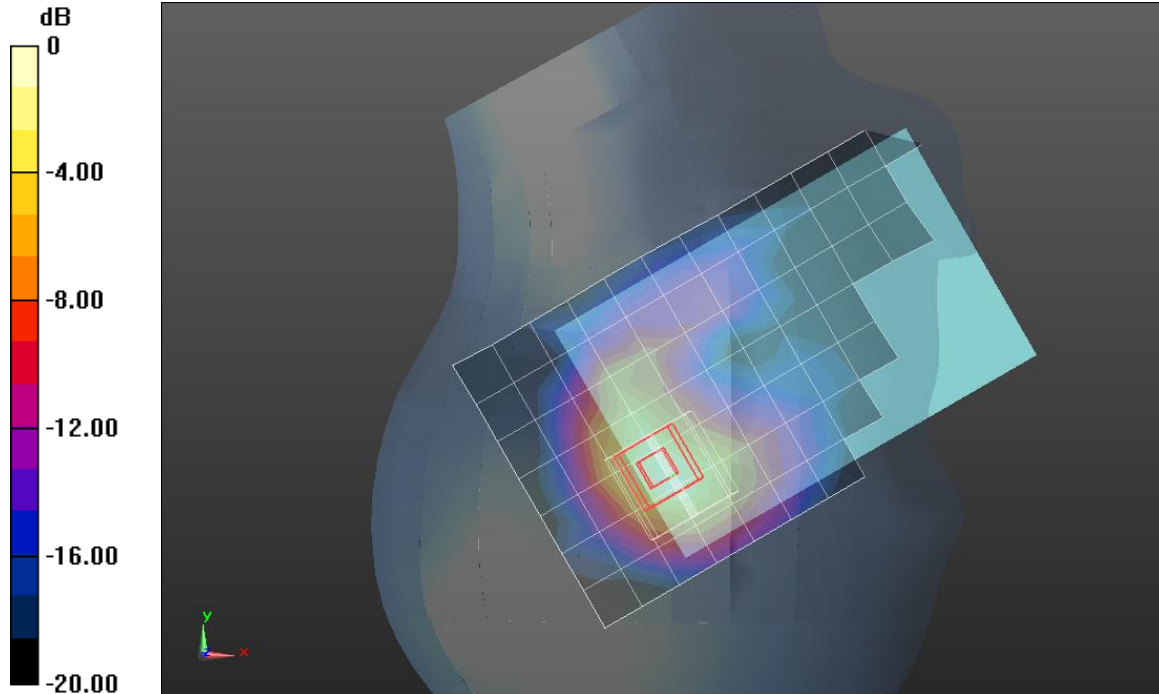

0 dB = 0.200mW/g = -13.98 dB mW/g

WiFi 2.4GHz

Frequency: 2462 MHz; Duty Cycle: 1:1

RHS/Touch, ch 11/Z Scan (1x1x21): Measurement grid: dx=20mm, dy=20mm, dz=5mm

[Info: Interpolated medium parameters used for SAR evaluation.](#)

Maximum value of SAR (measured) = 0.142 mW/g

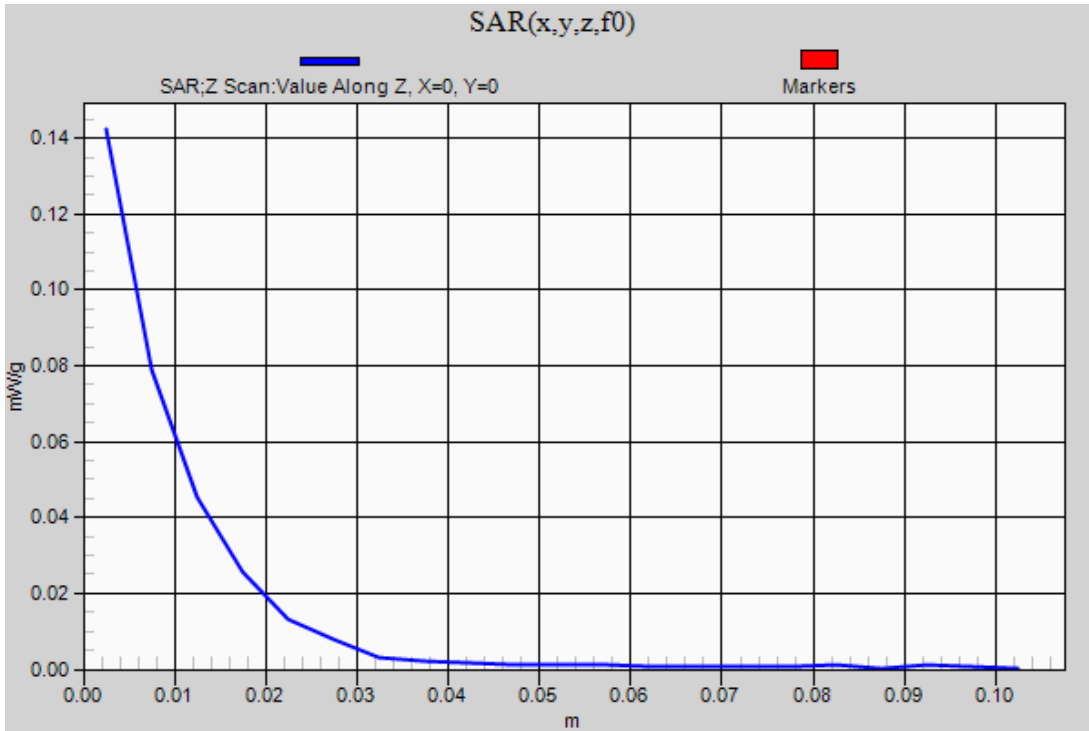

Test Laboratory: UL CCS SAR Lab C

Date: 5/1/2012

WiFi 2.4GHz

Frequency: 2462 MHz; Duty Cycle: 1:1; Room Ambient Temperature: 24.0°C; Liquid Temperature: 23.0°C
Medium parameters used (interpolated): $f = 2462$ MHz; $\sigma = 1.989$ mho/m; $\epsilon_r = 50.58$; $\rho = 1000$ kg/m³

DASY5 Configuration:

- Electronics: DAE3 Sn500; Calibrated: 7/14/2011
- Probe: EX3DV4 - SN3773; ConvF(6.67, 6.67, 6.67); Calibrated: 3/14/2012
- Sensor-Surface: 2.5mm (Mechanical Surface Detection)
- Phantom: ELI v5.0 (A); Type: QDOVA001BB; Serial: 1120

Rear/Ch 11/Area Scan (10x13x1): Measurement grid: dx=15mm, dy=15mm

[Info: Interpolated medium parameters used for SAR evaluation.](#)

Maximum value of SAR (measured) = 0.187 mW/g

Rear/Ch 11/Zoom Scan (5x5x7)/Cube 0: Measurement grid: dx=8mm, dy=8mm, dz=5mm

Reference Value = 9.739 V/m; Power Drift = -0.0026 dB

Peak SAR (extrapolated) = 0.2780

SAR(1 g) = 0.139 mW/g; SAR(10 g) = 0.069 mW/g

[Info: Interpolated medium parameters used for SAR evaluation.](#)

Maximum value of SAR (measured) = 0.183 mW/g

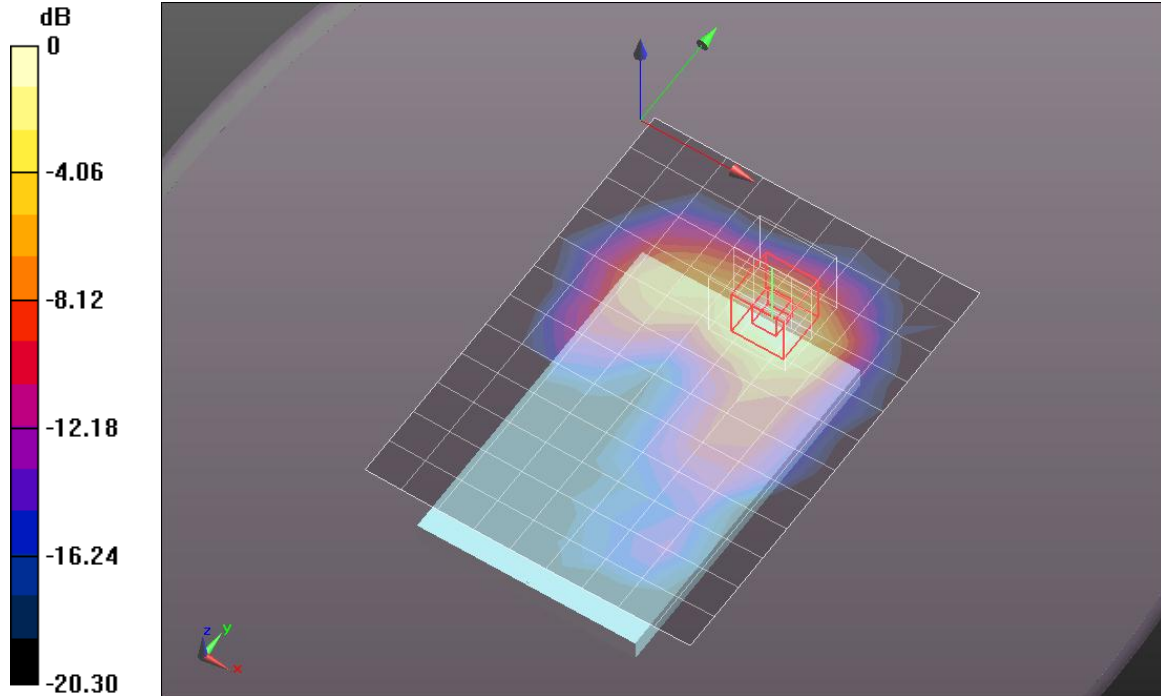

0 dB = 0.180mW/g = -14.89 dB mW/g

WiFi 2.4GHz

Frequency: 2462 MHz; Duty Cycle: 1:1

Rear/Ch 11/Z Scan (1x1x21): Measurement grid: dx=20mm, dy=20mm, dz=5mm

[Info: Interpolated medium parameters used for SAR evaluation.](#)

Maximum value of SAR (measured) = 0.186 mW/g

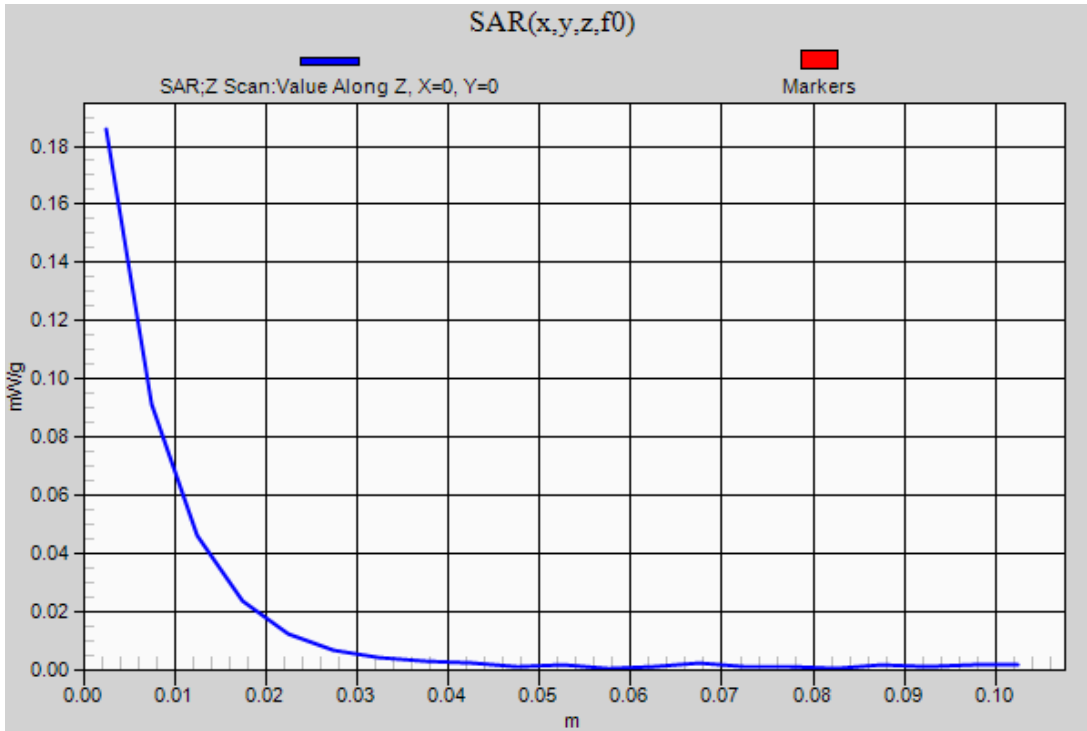

15. Simultaneous Transmission SAR Analysis

As its max average power is 10.72 mW [$<60/f(\text{GHz})$ mW], standalone SAR is not required for Bluetooth. Therefore, Bluetooth need not be considered in the simultaneous transmission SAR evaluation of other transmitters.

15.1. Head Exposure Conditions

15.1.1. Sum of the SAR for GSM, W-CDMA, & WiFi

Test Position	Voice			Data	Σ 1-g SAR (mW/g)
	GSM 850	GSM 1900	W-CDMA Band II	WiFi 2.4 GHz	
Left Touch	0.157			0.115	0.272
		0.142		0.115	0.257
			0.243	0.115	0.358
Left Tilt	0.094			0.105	0.199
		0.092		0.105	0.197
			0.156	0.105	0.261
Right Touch	0.153			0.151	0.304
		0.287		0.151	0.438
			0.564	0.151	0.715
Right Tilt	0.099			0.115	0.214
		0.072		0.115	0.187
			0.131	0.115	0.246

SAR to Peak Location Separation Ratio (SPLSR)

As the Sum of the SAR is not greater than 1.6 W/kg SPLSR assessment is not required.

Conclusion:

- Simultaneous transmission SAR measurement (Volume Scan) is not required because the sum of the 1-g SAR is < 1.6 W/kg.

15.1.2. Sum of the SAR for SV-DO & WiFi

Test Position	Voice		Data			Σ 1-g SAR (mW/g)
	CDMA BC0 1xRTT	CDMA BC1 1xRTT	CDMA BC0 1xEVDO	CDMA BC1 1xEVDO	WiFi 2.4 GHz	
Left Touch	0.261		0.332		0.115	0.708
	0.261			0.613	0.115	0.989
		0.348	0.332		0.115	0.795
		0.348		0.613	0.115	1.076
Left Tilt	0.154		0.260		0.105	0.519
	0.154			0.282	0.105	0.541
		0.241	0.260		0.105	0.606
		0.241		0.282	0.105	0.628
Right Touch	0.223		0.174		0.151	0.548
	0.223			0.138	0.151	0.512
		0.801	0.174		0.151	1.126
		0.801		0.138	0.151	1.090
RightTilt	0.152		0.148		0.115	0.415
	0.152			0.062	0.115	0.329
		0.210	0.148		0.115	0.473
		0.210		0.062	0.115	0.387

SAR to Peak Location Separation Ratio (SPLSR)

As the Sum of the SAR is not greater than 1.6 W/kg SPLSR assessment is not required.

Conclusion:

- Simultaneous transmission SAR measurement (Volume Scan) is not required because the sum of the 1-g SAR is < 1.6 W/kg.

15.1.3. Sum of the SAR for SV-LTE & WiFi

Test Position	Voice		Data		Σ 1-g SAR (mW/g)
	CDMA BC0 1xRTT	CDMA BC1 1xRTT	LTE Band 13	WiFi 2.4 GHz	
Left Touch	0.261		0.134	0.115	0.510
		0.348	0.134	0.115	0.597
Left Tilt	0.154		0.094	0.105	0.353
		0.241	0.094	0.105	0.440
Right Touch	0.223		0.112	0.151	0.486
		0.801	0.112	0.151	1.064
RightTilt	0.152		0.64	0.115	0.907
		0.210	0.64	0.115	0.965

SAR to Peak Location Separation Ratio (SPLSR)

As the Sum of the SAR is not greater than 1.6 W/kg SPLSR assessment is not required.

Conclusion:

- Simultaneous transmission SAR measurement (Volume Scan) is not required because the sum of the 1-g SAR is < 1.6 W/kg.

15.2. Body Exposure Conditions

15.2.1. Sum of the SAR for WCDMA & WiFi

Test Position	Data		Σ 1-g SAR (mW/g)
	WCDMA Band II	WiFi 2.4 GHz	
Rear	0.828	0.139	0.967
Front	0.41	0.050	0.460
Edge 1	0	0.055	0.055
Edge 2	0.312	0	0.312
Edge 3	0.457	0	0.457
Edge 4	0	0	0

SAR to Peak Location Separation Ratio (SPLSR)

As the Sum of the SAR is not greater than 1.6 W/kg SPLSR assessment is not required.

Conclusion:

- Simultaneous transmission SAR measurement (Volume Scan) is not required because the sum of the 1-g SAR is < 1.6 W/kg.

15.2.2. Sum of the SAR for SV-DO & WiFi

Test Position	Voice		Data			Σ 1-g SAR (mW/g)
	CDMA BC0 1xRTT	CDMA BC1 1xRTT	CDMA BC0 1xEVDO	CDMA BC1 1xEVDO	WiFi 2.4 GHz	
Rear	0.894		0.493		0.139	1.526
	0.894			1.03	0.139	2.063
		1.24	0.493		0.139	1.872
		1.24		1.03	0.139	2.409
Front	0.364		0.162		0.050	0.576
	0.364			0.122	0.050	0.536
		0.582	0.162		0.050	0.794
		0.582		0.122	0.050	0.754
Edge 1	0		0.094		0.055	0.149
	0			0.061	0.055	0.116
		0	0.094		0.055	0.149
		0		0.061	0.055	0.116
Edge 2	0.124		0.153		0	0.277
	0.124			0.436	0	0.560
		0.409	0.153		0	0.562
		0.409		0.436	0	0.845
Edge 3	0.189		0		0	0.189
	0.189			0	0	0.189
		0.643	0		0	0.643
		0.643		0	0	0.643
Edge 4	0		0		0	0
	0			0	0	0
		0	0		0	0
		0		0	0	0

SAR to Peak Location Separation Ratio (SPLSR)

Case #	Test Position	Worst-case combination					Σ 1-g SAR (mW/g)	Calculated distance (cm)	SPLSR	Figure
		CDMA BC0 1xRTT	CDMA BC1 1xRTT	CDMA BC0 1xEVDO	CDMA BC1 1xEVDO	WiFi 2.4 GHz				
1	Rear	0.894			1.030	0.139	2.063			
		0.894				0.139	1.033	12.17	0.085	1
					1.030	0.139	1.169	5.05	0.231	2
		0.894			1.030		1.924	10.83	0.178	3
2	Rear		1.24	0.493		0.139	1.872			
			1.24			0.139	1.379	13.81	0.100	4
				0.493		0.139	0.632	5.31	0.119	5
			1.24	0.493			1.733	11.56	0.150	6
3	Rear		1.24		1.030	0.139	2.409			
			1.24			0.139	1.379	13.81	0.100	4
					1.030	0.139	1.169	5.05	0.231	2
			1.24		1.030		2.270	11.83	0.192	7

Conclusion:

- Simultaneous transmission SAR measurement (Volume Scan) is not required because the sum of the 1-g SAR is < 1.6 W/kg and the SPLSR for at least one antenna pairing combination is < 0.3.

15.2.3. Sum of the SAR for SV-LTE & WiFi

Test Position	Voice		Data		Σ 1-g SAR (mW/g)
	CDMA BC0 1xRTT	CDMA BC1 1xRTT	LTE Band 13	WiFi 2.4 GHz	
Rear	0.894		0.576	0.139	1.609
		1.24	0.576	0.139	1.955
Front	0.364		0.232	0.050	0.646
		0.582	0.232	0.050	0.864
Edge 1	0		0	0.055	0.055
		0	0	0.055	0.055
Edge 2	0.124		0	0	0.124
		0.409	0	0	0.409
Edge 3	0.189		0.261	0	0.450
		0.643	0.261	0	0.904
Edge 4	0		0.143	0	0.143
		0	0.143	0	0.143

SAR to Peak Location Separation Ratio (SPLSR)

Case #	Test Position	Worst-case combination				Σ 1-g SAR (mW/g)	Calculated distance (cm)	SPLSR	Figure
		CDMA BC0 1xRTT	CDMA BC1 1xRTT	LTE Band 13	WiFi 2.4 GHz				
4	Rear	0.894		0.576	0.139	1.609			
		0.894			0.139	1.033	12.17	0.085	1
				0.576	0.139	0.715	12.44	0.057	8
		0.894		0.576		1.470	3.33	0.441	9
5	Rear		1.240	0.576	0.139	1.955			
			1.240		0.139	1.379	13.81	0.100	4
				0.576	0.139	0.715	12.44	0.057	8
			1.240	0.576		1.816	5.08	0.357	10

Conclusion:

- Simultaneous transmission SAR measurement (Volume Scan) is required for Cases #4 and #5 because the sum of the 1-g SAR is > 1.6 W/kg and the SPLSR for at least one antenna pairing combination is > 0.3.

15.3. SAR Peak Location Separation Distance Calculations and Figures

Figure (1)

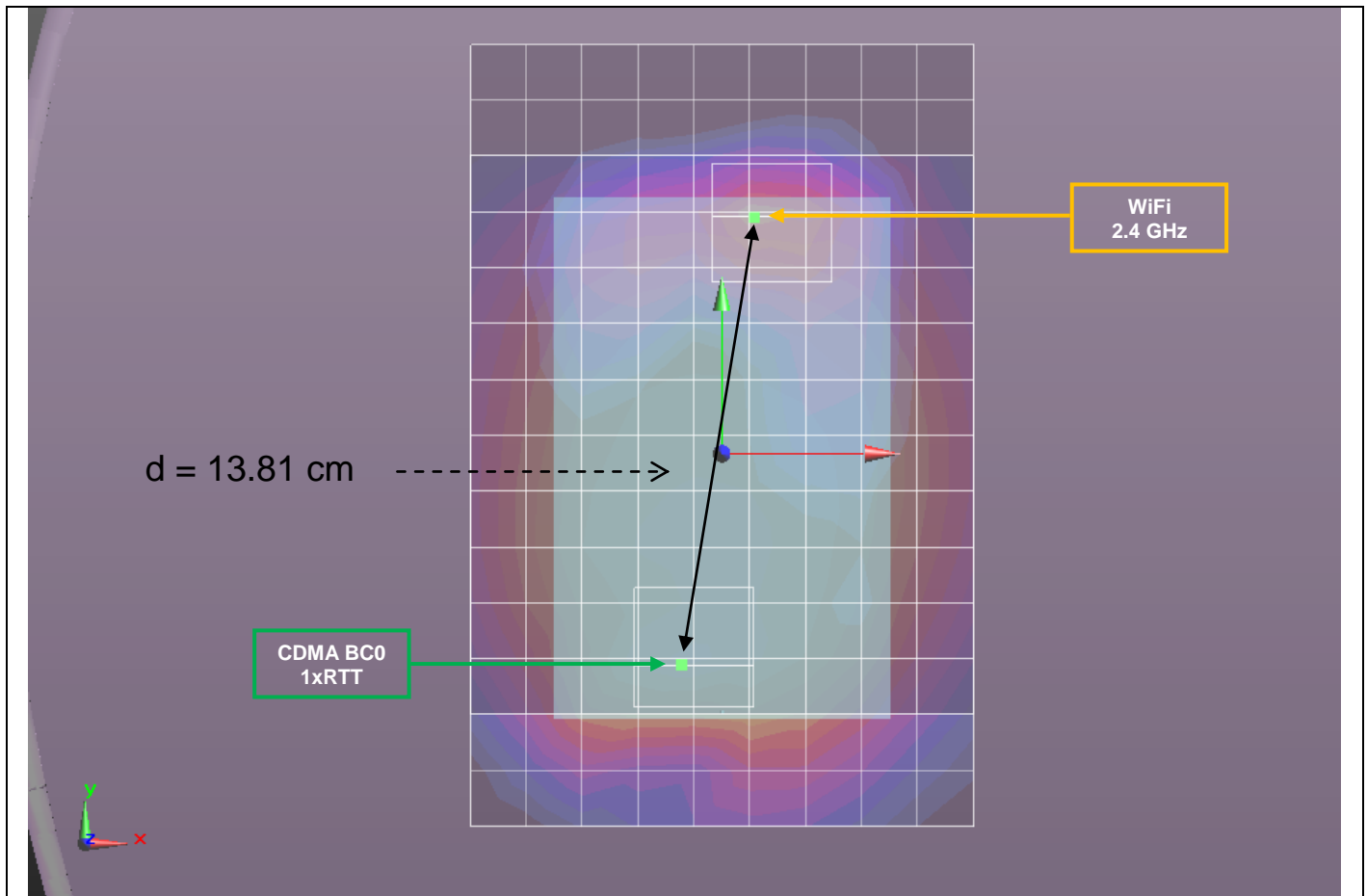

Mode	Peak SAR mW/g	X m	Y m	Z m
CDMA BC0, 1xRTT	1.47	-0.0091	-0.0568	-0.185
WiFi 2.4 GHz	0.278	0.0087	0.0636	-0.185
d: Calculated distance (cm)				
12.17				

The Peak Location Separation Distance is computed by using the formula below:

$$\sqrt{3} \sqrt{(X1-X2)^2+(Y1-Y2)^2+(Z1-Z2)^2}$$

Figure (2)

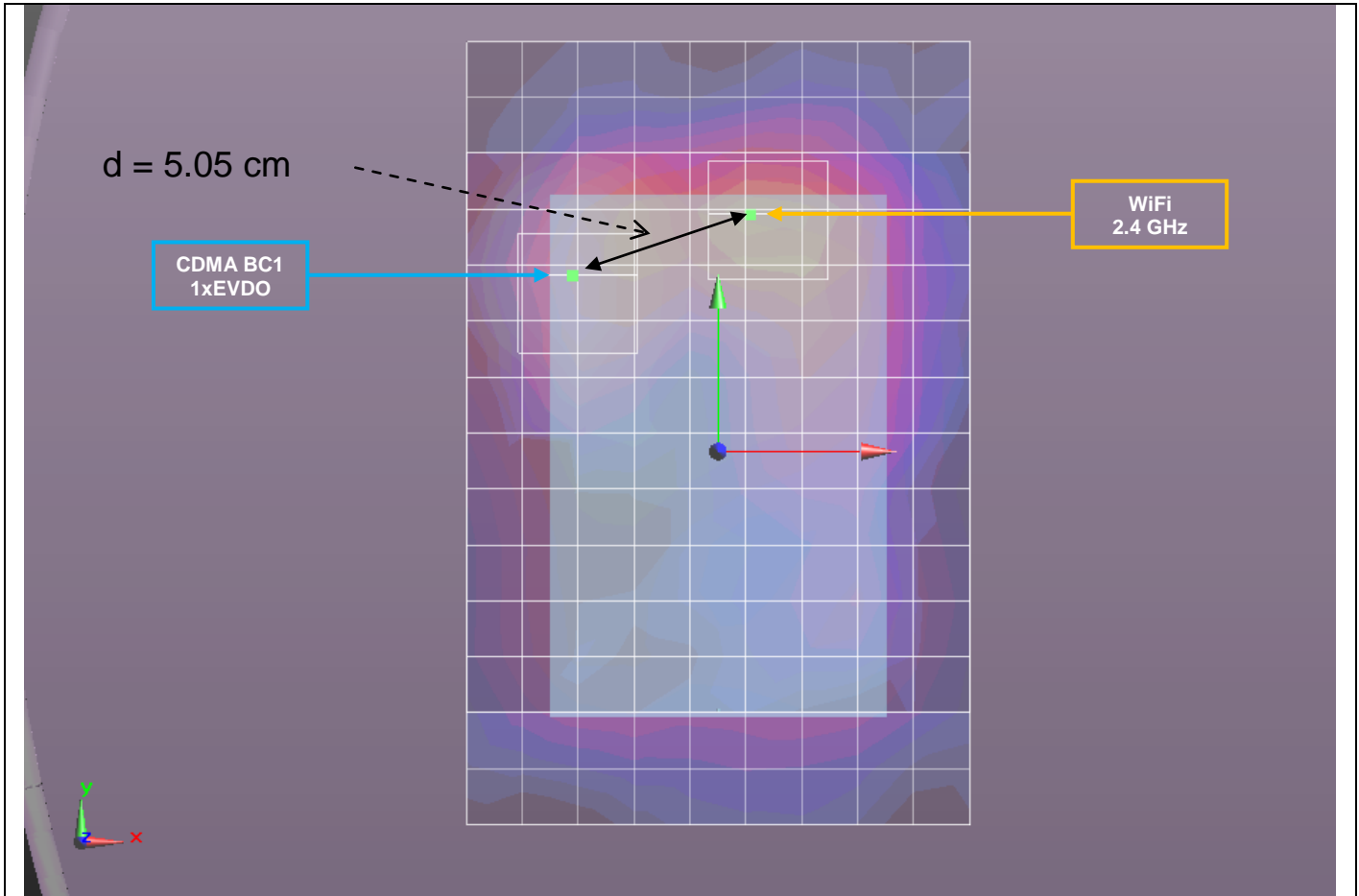

Mode	Peak SAR	X	Y	Z
	mW/g	m	m	m
CDMA BC1, 1xEVDO	1.8	-0.0391	0.0473	-0.184
WiFi 2.4 GHz	0.278	0.0087	0.0636	-0.185

d: Calculated distance (cm)
5.05

The Peak Location Separation Distance is computed by using the formula below:
 $\sqrt[3]{(X1-X2)^2+(Y1-Y2)^2+(Z1-Z2)^2}$

Figure (3)

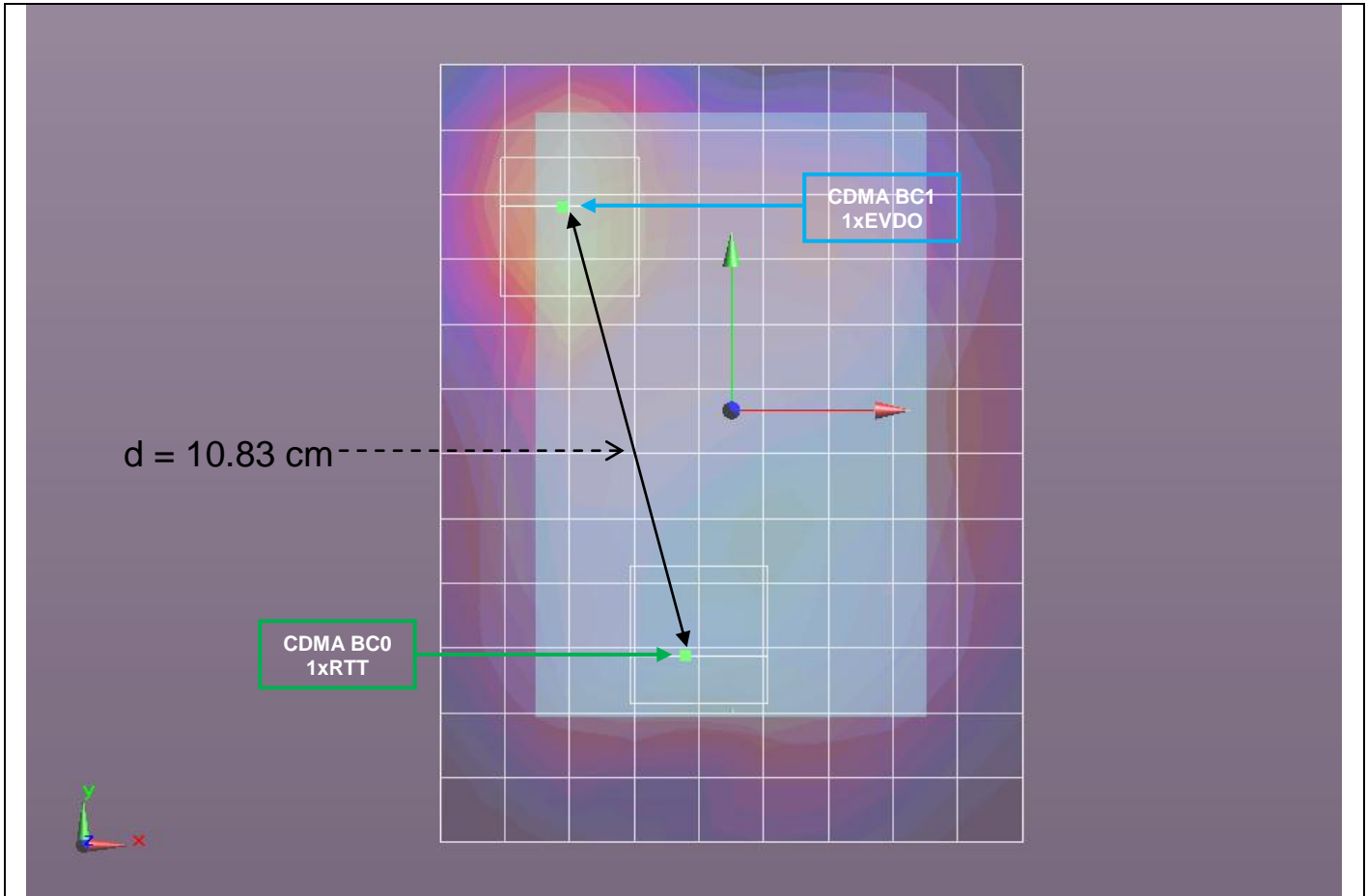

Mode	Peak SAR mW/g	X m	Y m	Z m
CDMA BC0, 1xRTT	1.47	-0.0091	-0.0568	-0.185
CDMA BC1, 1xEVDO	1.8	-0.0391	0.0473	-0.184

d: Calculated distance (cm)
10.83

The Peak Location Separation Distance is computed by using the formula below:
 $\sqrt[3]{(X1-X2)^2+(Y1-Y2)^2+(Z1-Z2)^2}$

Figure (4)

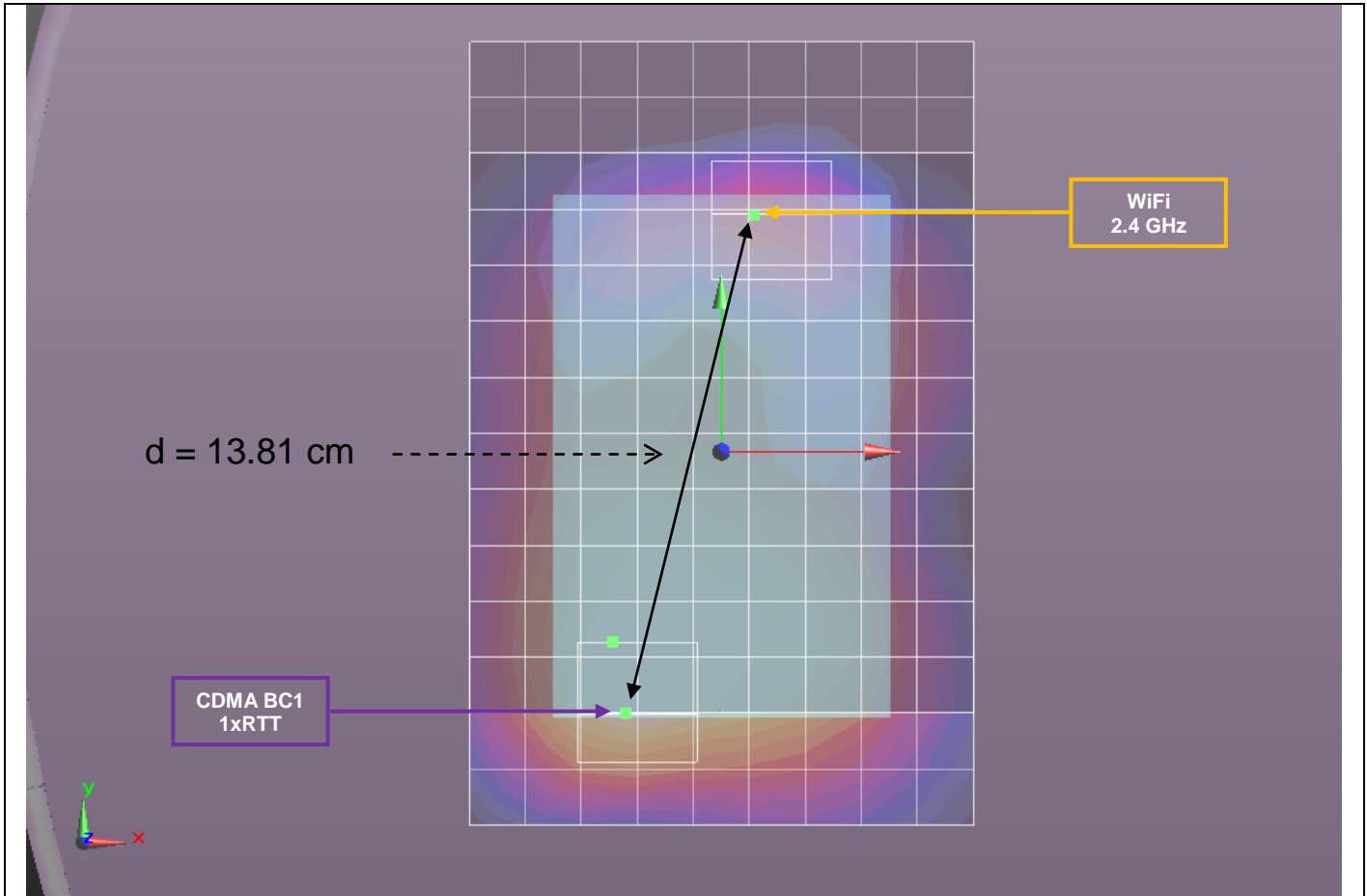

Mode	Peak SAR	X	Y	Z
	mW/g	m	m	m
CDMA BC1, 1xRTT	2.13	-0.0256	-0.0702	-0.184
WiFi 2.4 GHz	0.278	0.0087	0.0636	-0.185
d: Calculated distance (cm)				
13.81				

The Peak Location Separation Distance is computed by using the formula below:

$$\sqrt[3]{(X1-X2)^2+(Y1-Y2)^2+(Z1-Z2)^2}$$

Figure (5)

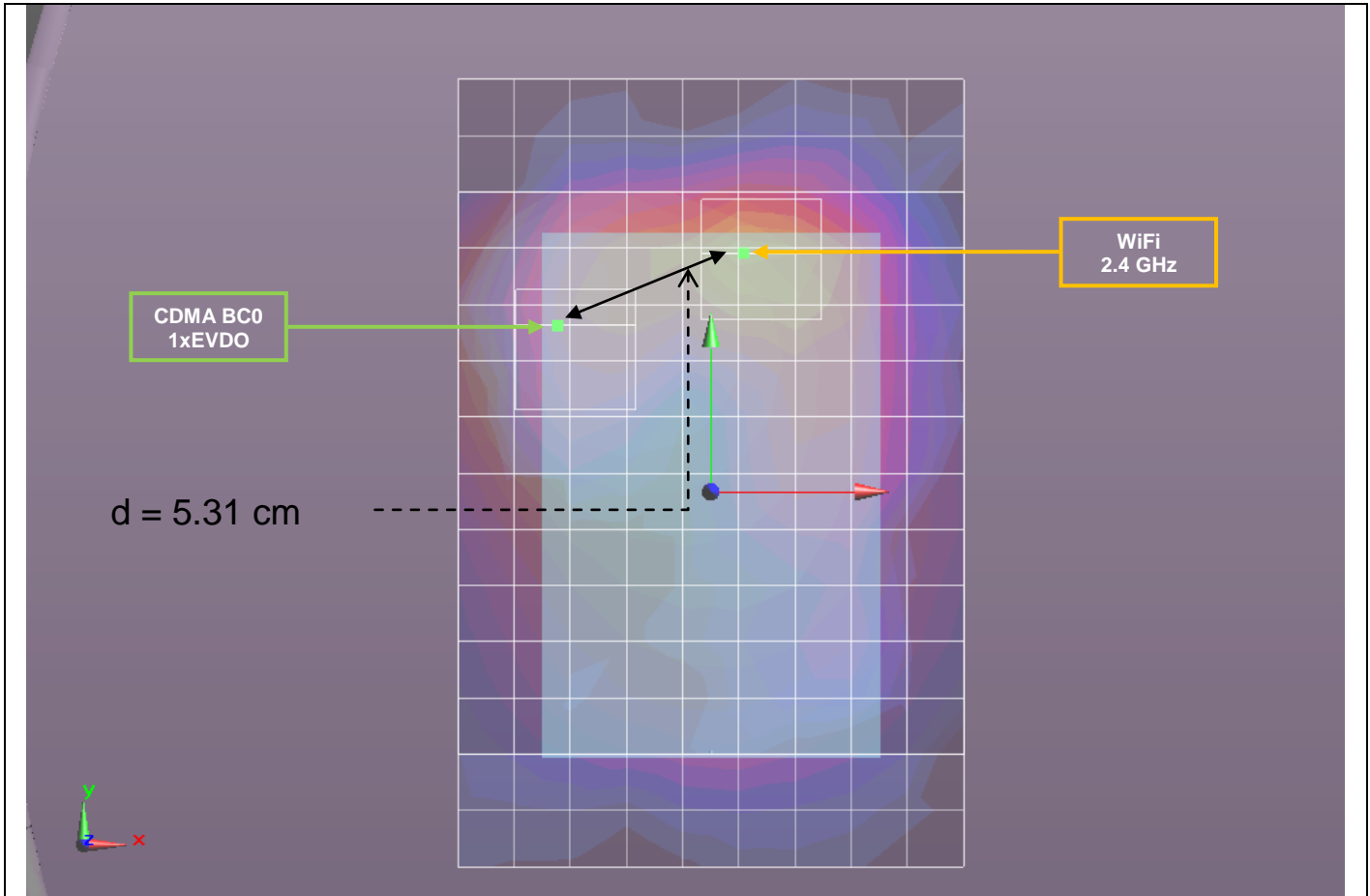

Mode	Peak SAR mW/g	X m	Y m	Z m
CDMA BC0, 1xEVDO	0.886	-0.0408	0.0444	-0.185
WiFi 2.4 GHz	0.278	0.0087	0.0636	-0.185

d: Calculated distance (cm)
5.31

The Peak Location Separation Distance is computed by using the formula below:

$$\sqrt[3]{(X1-X2)^2+(Y1-Y2)^2+(Z1-Z2)^2}$$

Figure (6)

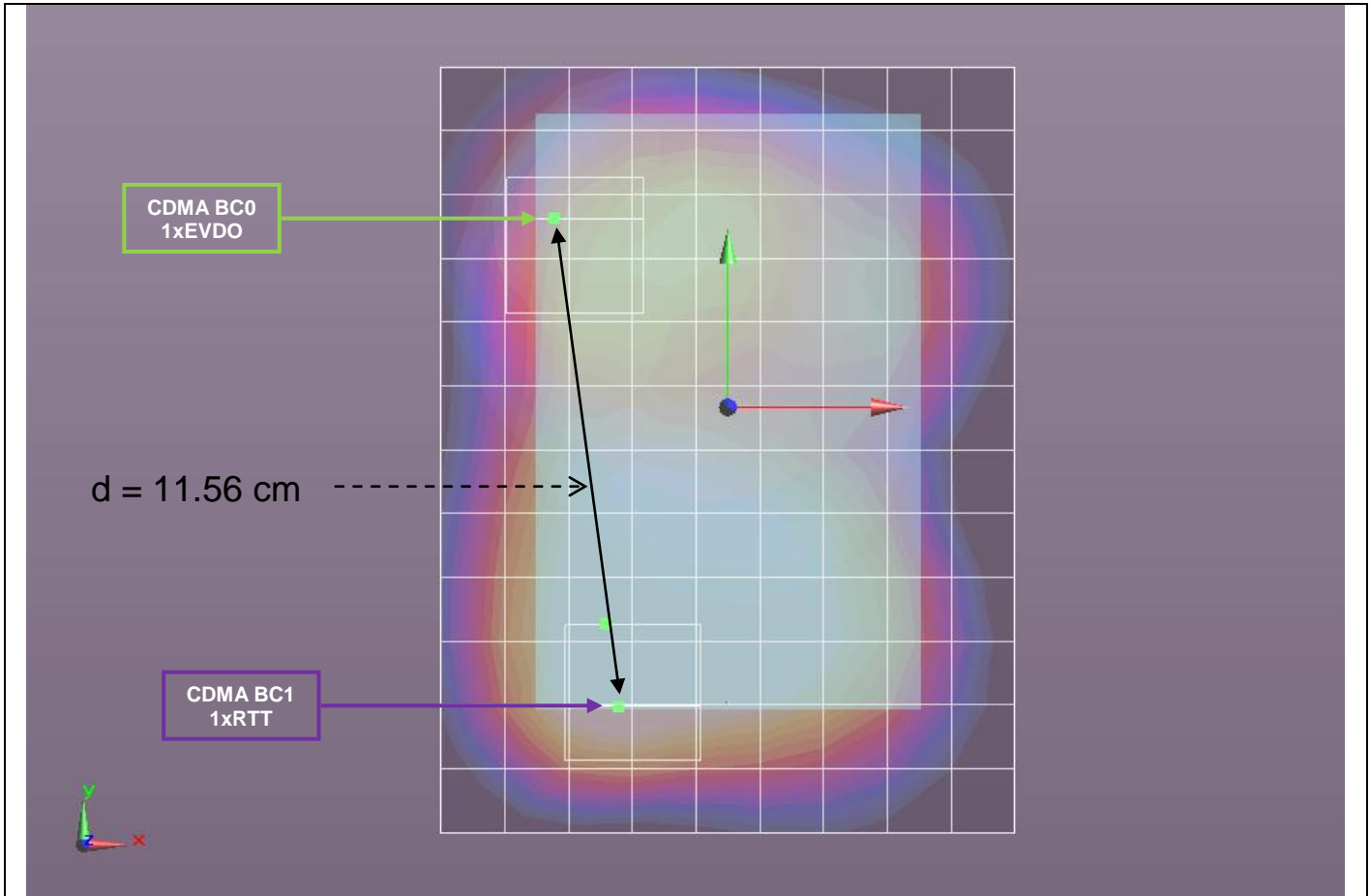

Mode	Peak SAR	X	Y	Z
	mW/g	m	m	m
CDMA BC1, 1xRTT	2.13	-0.0256	-0.0702	-0.184
CDMA BC0, 1xEVDO	0.886	-0.0408	0.0444	-0.185

d: Calculated distance (cm)
11.56

The Peak Location Separation Distance is computed by using the formula below:

$$\sqrt[3]{(X1-X2)^2+(Y1-Y2)^2+(Z1-Z2)^2}$$

Figure (7)

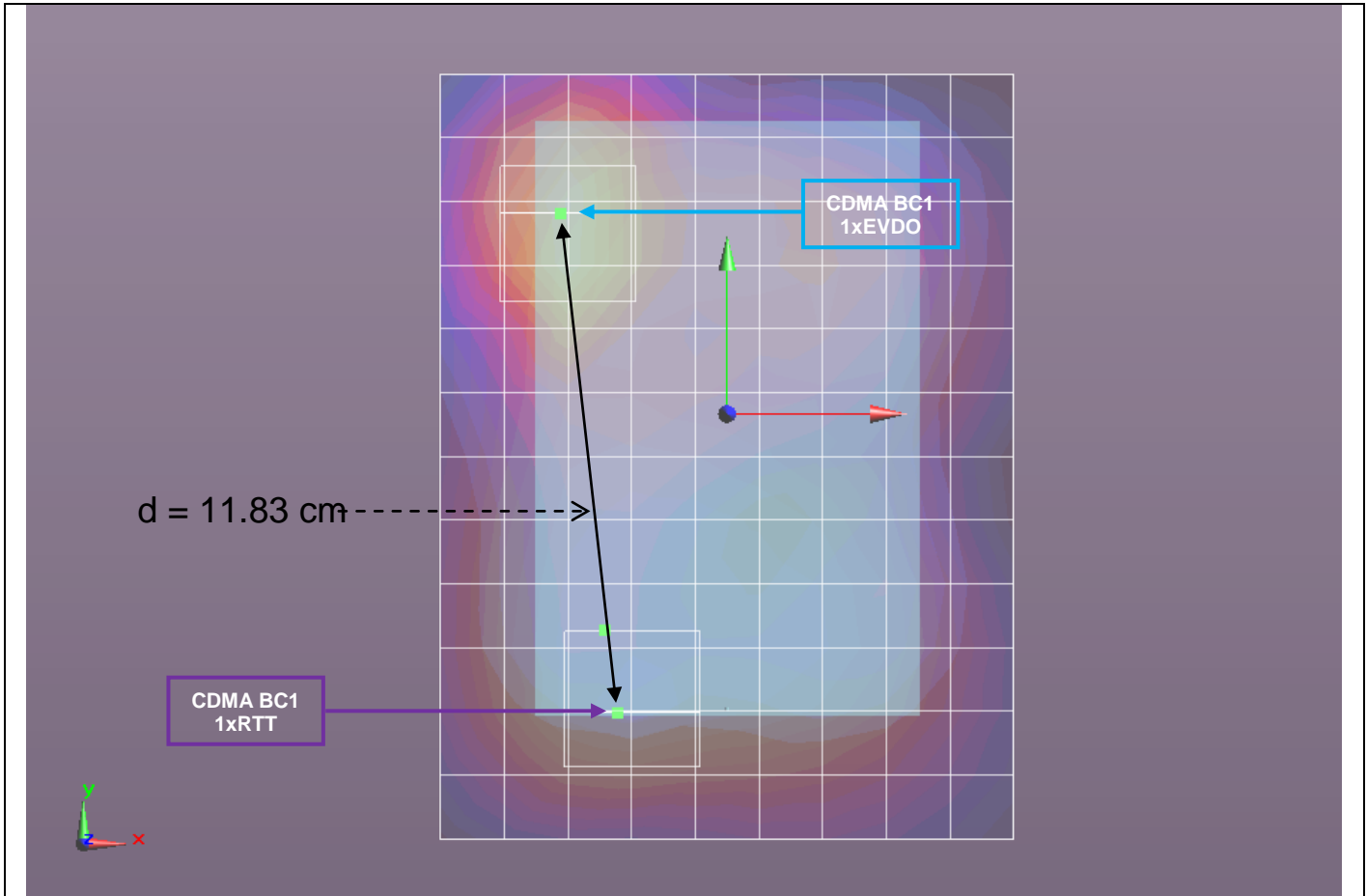

Mode	Peak SAR mW/g	X m	Y m	Z m
CDMA BC1, 1xRTT	2.13	-0.0256	-0.0702	-0.184
CDMA BC1, 1xEVDO	1.8	-0.0391	0.0473	-0.184

d: Calculated distance (cm)
11.83

The Peak Location Separation Distance is computed by using the formula below:

$$\sqrt[3]{(X1-X2)^2+(Y1-Y2)^2+(Z1-Z2)^2}$$

Figure (8)

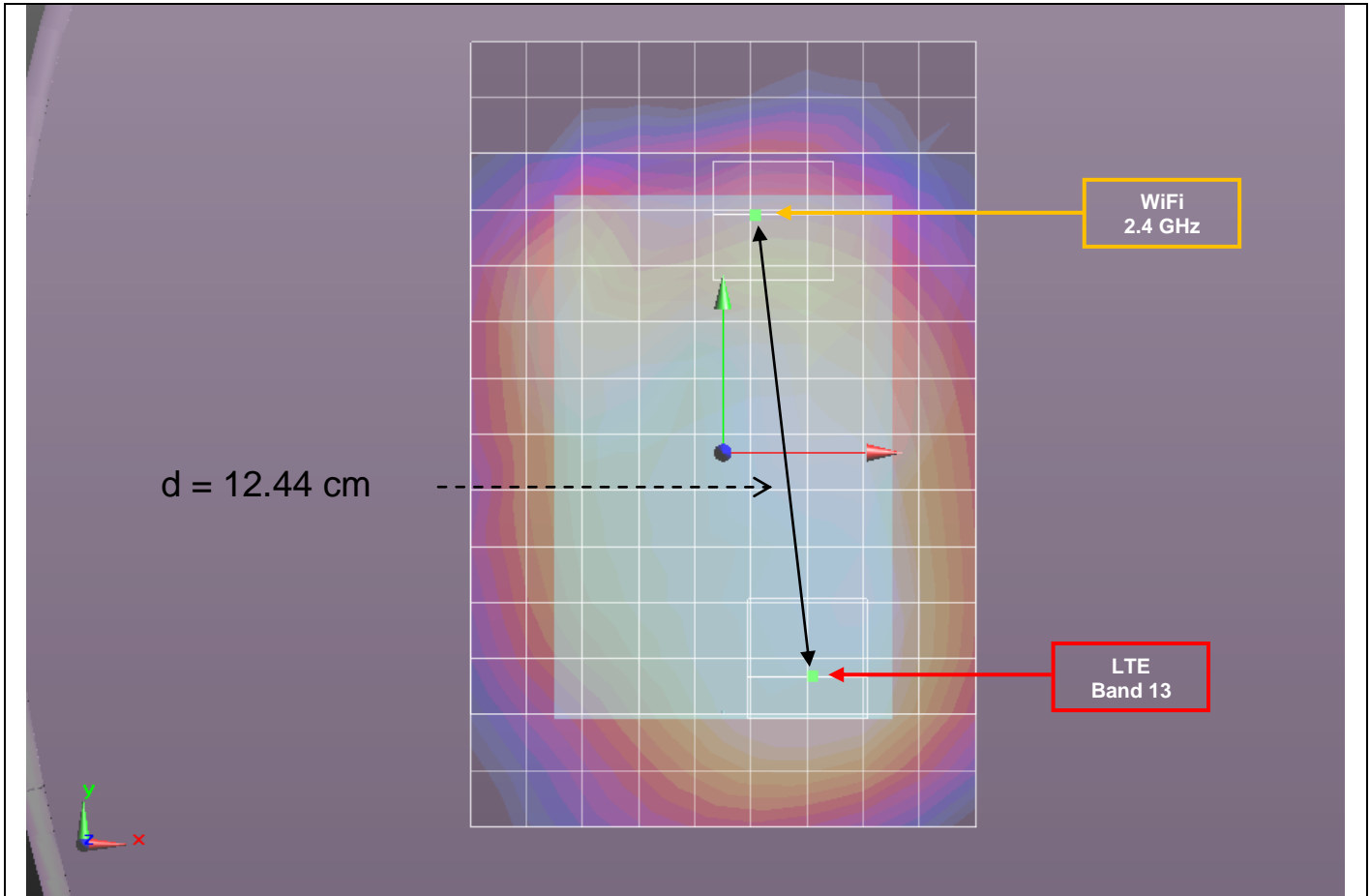

Mode	Peak SAR mW/g	X m	Y m	Z m
LTE Band 13	0.979	0.0241	-0.0598	-0.185
WiFi 2.4 GHz	0.278	0.0087	0.0636	-0.185

d: Calculated distance (cm)
12.44

The Peak Location Separation Distance is computed by using the formula below:

$$\sqrt[3]{\text{QRT}((X1-X2)^2+(Y1-Y2)^2+(Z1-Z2)^2)}$$

Figure (9)

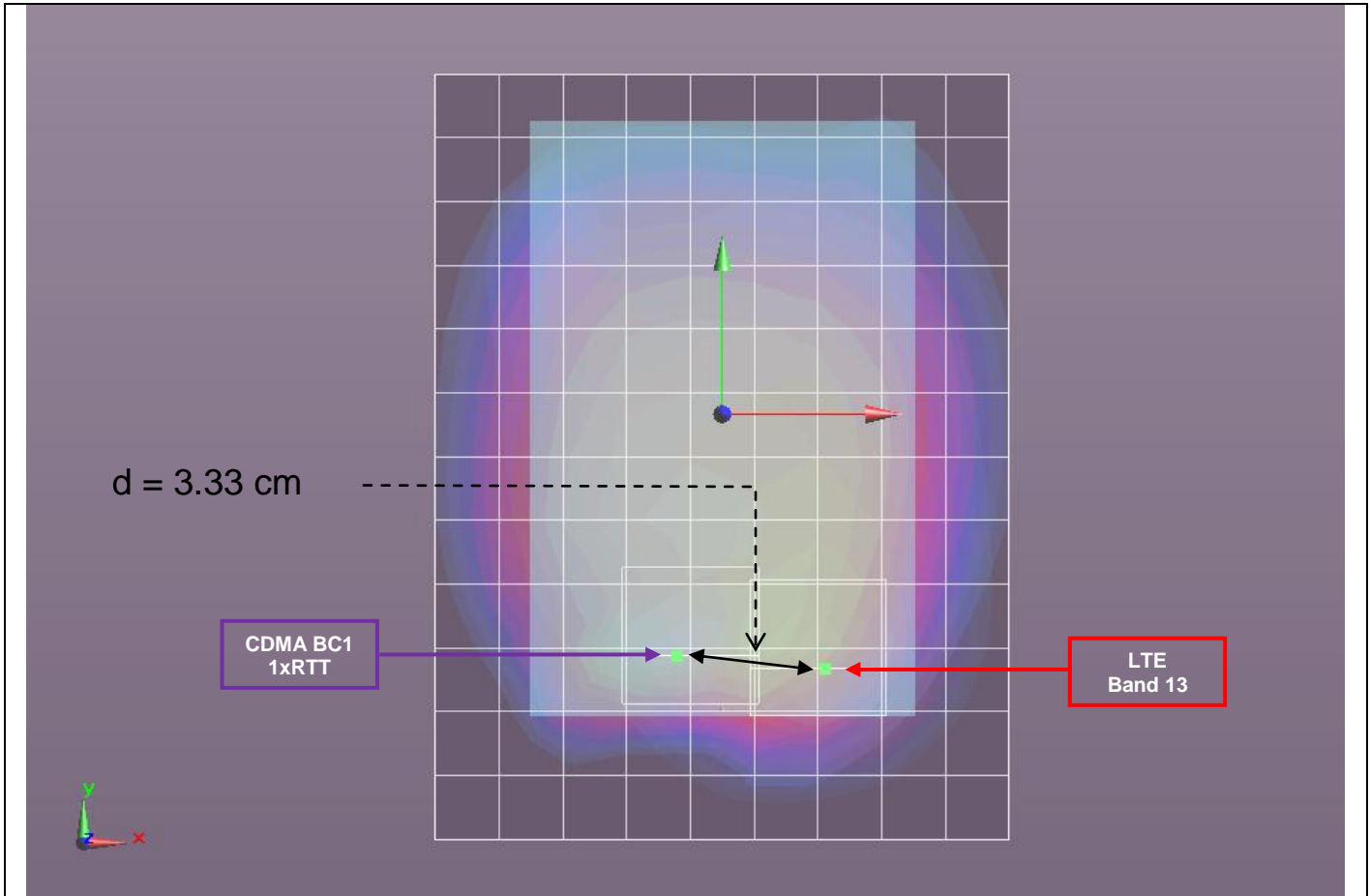

Mode	Peak SAR mW/g	X m	Y m	Z m
CDMA BC0, 1xRTT	1.47	-0.0091	-0.0568	-0.185
LTE Band 13	0.979	0.0241	-0.0598	-0.185

d: Calculated distance (cm)
3.33

The Peak Location Separation Distance is computed by using the formula below:

$$\sqrt[3]{\text{QRT}((X1-X2)^2+(Y1-Y2)^2+(Z1-Z2)^2)}$$

Figure (10)

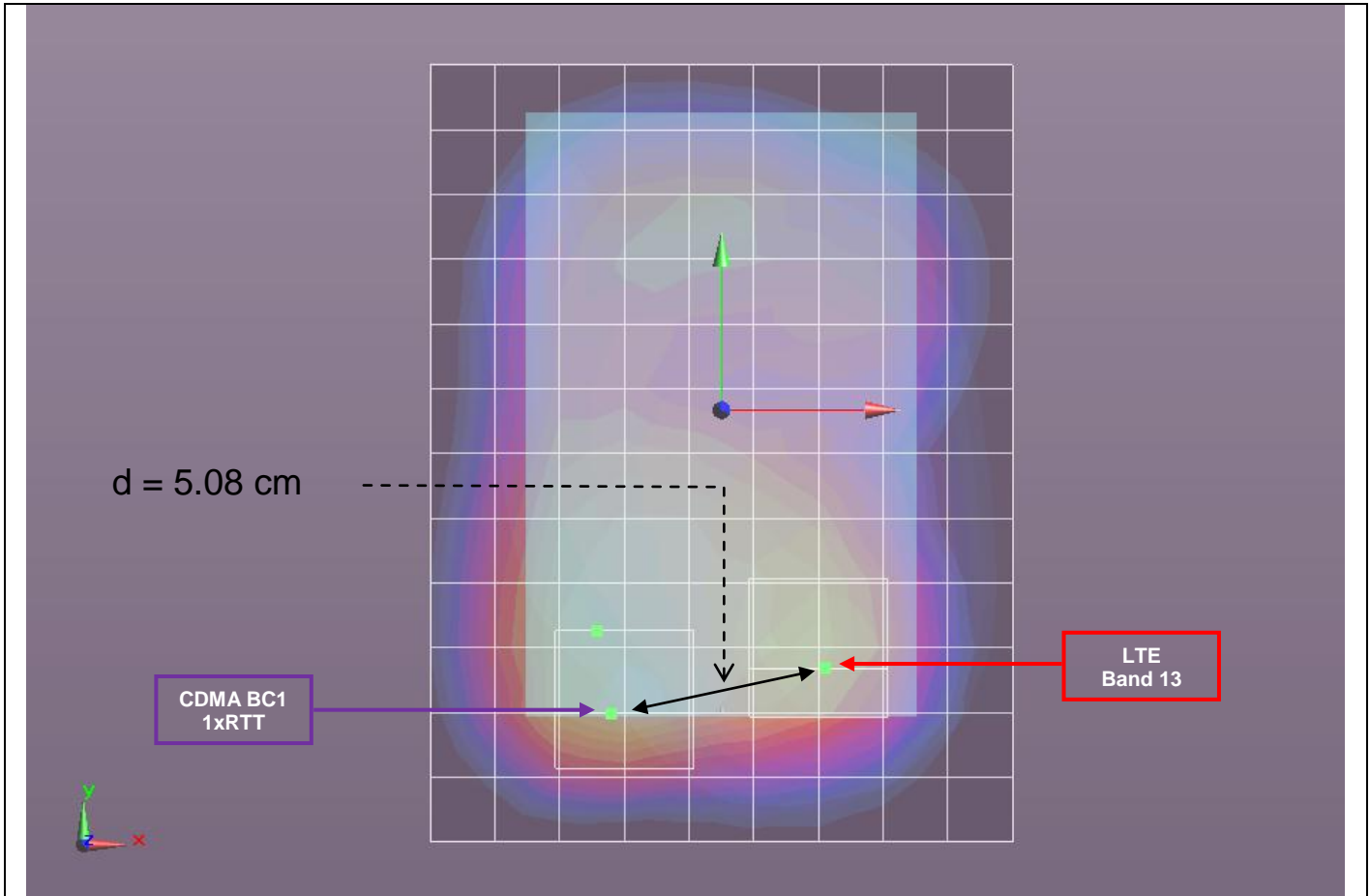

Mode	Peak SAR	X	Y	Z
	mW/g	m	m	m
CDMA BC1, 1xRTT	2.13	-0.0256	-0.0702	-0.184
LTE Band 13	0.979	0.0241	-0.0598	-0.185

d: Calculated distance (cm)
5.08

The Peak Location Separation Distance is computed by using the formula below:

$$\sqrt[3]{(X1-X2)^2+(Y1-Y2)^2+(Z1-Z2)^2}$$

15.4. Multi-Band Volume Scan Combined Results

Case #	Test position	Multi-band	Standalone Results		Multi-Band Combined Results
			Zoom Scan	Volume Scan	
4	Rear	CDMA BC0 1xRTT	0.894	0.865	1.05
		LTE Band 13	0.576	0.573	
		WiFi 2.4GHz	0.139	0.144	
5	Rear	CDMA BC1 1xRTT	1.24	1.2	1.26
		LTE Band 13	0.576	0.573	
		WiFi 2.4GHz	0.139	0.144	

Note(s):

1. See Appendix 16.9_SAR test plots for SV-LTE volume scans.
2. See Appendix 16.10_SAR test plots for SV-LTE Multi band results

16. Appendixes

Refer to separated files for the following appendixes.

- 16.1. System Performance Check Plots
- 16.2. SAR Test Plots for GSM850
- 16.3. SAR Test Plots for GSM1900
- 16.4. SAR Test Plots for W-CDMA (UMTS) Band II
- 16.5. SAR Test Plots for CDMA BC0
- 16.6. SAR Test Plots for CDMA BC1
- 16.7. SAR Test Plots for LTE Band 13
- 16.8. SAR Test Plots for WiFi 2.4 GHz Band
- 16.9. SAR test plots for SV-LTE Volume Scans
- 16.10. SAR test plots for SV-LTE Multi band results
- 16.11. Calibration Certificate for E-Field Probe EX3DV4 - SN 3773
- 16.12. Calibration Certificate for D750V3 - SN 1019
- 16.13. Calibration Certificate for D835V2 - SN 4d002
- 16.14. Calibration Certificate for D1900V2 - SN 5d043
- 16.15. Calibration Certificate for D2450V2 - SN 748