



FCC CFR47 PART 20.19

ANSI C63.19-2007

(Class II Permissive Change)

HAC RF EMISSIONS TEST REPORT

For

Cellular/PCS CDMA/GSM/WCDMA & LTE Phone w/ BT & WLAN + NFC

Model: LG-VS930

FCC ID: ZNFVS930

REPORT NUMBER: 12U14433-8

ISSUE DATE: 6/18/2012

Prepared for

**LG ELECTRONICS MOBILECOMM U.S.A., INC.
1000 SYLVAN AVE. ENGLEWOOD CLIFFS, NJ
UNITED STATES 07632**

Prepared by

**COMPLIANCE CERTIFICATION SERVICES (UL CCS)
47173 BENICIA STREET
FREMONT, CA 94538, U.S.A.
TEL: (510) 771-1000
FAX: (510) 661-0888**



NVLAP LAB CODE 200065-0

Revision History

<u>Rev.</u>	<u>Issue Date</u>	<u>Revisions</u>	<u>Revised By</u>
--	6/18/2012	Initial Issue	--

Tablet of Contents

1. Attestation of Test Results	4
2. Test Methodology	5
3. Facilities and Accreditation	5
4. Calibration and Uncertainty	6
4.1. <i>Measuring Instrument Calibration</i>	6
4.2. <i>Measurement Uncertainty</i>	7
5. Equipment Under Test	8
5.1. <i>List of Air Interfaces/Bands & Operating Modes</i>	8
6. System Specifications	9
7. System Validation	10
7.1. <i>System Validation Results</i>	11
8. Probe Modulation Factor (PMF)	12
8.1. <i>PMF Measurement Results</i>	14
9. HAC RF Emissions Test Procedure	15
10. RF Emissions Measurement Criteria	17
11. HAC (RF Emissions) Test Results	18
11.1. <i>E-Field Emissions</i>	18
11.2. <i>H- Field Emissions</i>	19
12. Worst-case Test Plots	20
13. Appendixes	24
13.1. <i>System Validation Plots</i>	24
13.2. <i>E-field emissions test plots</i>	24
13.3. <i>H-field emissions test plots</i>	24
13.4. <i>Calibration Certificate - E-Field Probe ER3DV6 - SN 2339</i>	24
13.5. <i>Calibration Certificate - H-Field Probe H3DV6 - SN 6157</i>	24
13.6. <i>Calibration Certificate for Dipole CD835V3 - SN 1014</i>	24
13.7. <i>Calibration Certificate for Dipole CD1880V3 - SN 1122</i>	24
14. Setup Photo	25

1. Attestation of Test Results

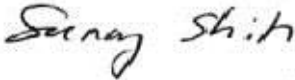
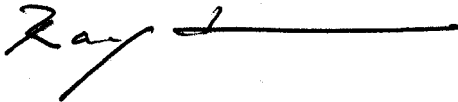
Applicant name	LG ELECTRONICS MOBILECOMM U.S.A., INC.		
DUT description	Cellular/PCS CDMA/GSM/WCDMA & LTE Phone w/ BT & WLAN + NFC		
Model name	ZNFVS930 IMEI:990000760007379		
Test device is	An identical prototype		
Device category	Portable		
Exposure category	General Population/Uncontrolled Exposure		
Dates tested	6/6/2012 – 6/7/2012		
Maximum E/H-Filed Emissions			
Max. E-Field emissions	Part 22 - Cellular band:	154.6V/m (M4)	
	Part 24 - PCS band:	50.327 V/m (M3)	
Max. H-Field emissions	Part 22 - Cellular band:	0.233 A/m (M4)	
	Part 24 - PCS band:	0.155 A/m (M3)	
Hearing Aid Near-Field Category: M3			
Applicable Standards		Test Results	
ANSI C63.19-2007		Pass	
<p>Compliance Certification Services, Inc. (UL CCS) tested the above equipment in accordance with the requirements set forth in the above standards. All indications of Pass/Fail in this report are opinions expressed by UL CCS based on interpretations and/or observations of test results. Measurement Uncertainties were not taken into account and are published for informational purposes only. The test results show that the equipment tested is capable of demonstrating compliance with the requirements as documented in this report.</p> <p>Note: The results documented in this report apply only to the tested sample, under the conditions and modes of operation as described herein. This document may not be altered or revised in any way unless done so by UL CCS and all revisions are duly noted in the revisions section. Any alteration of this document not carried out by UL CCS will constitute fraud and shall nullify the document. This report must not be used by the client to claim product certification, approval, or endorsement by NVLAP, NIST, any agency of the Federal Government, or any agency of any government (NIST Handbook 150, Annex A). This report is written to support regulatory compliance of the applicable standards stated above.</p>			
Approved & Released For UL CCS By:		Tested By:	
			
Sunny Shih Engineering Leader Compliance Certification Services (UL CCS)		Ray Su SAR Engineer Compliance Certification Services (UL CCS)	

2. Test Methodology

The tests documented in this report were performed in accordance with ANSI C63.19-2007 Methods of Measurement of Compatibility between Wireless Communications Devices and Hearing Aids and FCC KDB 285076 D01 HAC Guidance v02r01

3. Facilities and Accreditation

The test sites and measurement facilities used to collect data are located at 47173 Benicia Street, Fremont, California, USA.

UL CCS is accredited by NVLAP, Laboratory Code 200065-0. The full scope of accreditation can be viewed at <http://www.ccsemc.com>.

4. Calibration and Uncertainty

4.1. Measuring Instrument Calibration

The measuring equipment utilized to perform the tests documented in this report has been calibrated in accordance with the manufacturer's recommendations, and is traceable to recognized national standards.

Name of Equipment	Manufacturer	Type/Model	Serial No.	Cal. Due date		
				MM	DD	Year
Robot - Six Axes	Stäubli	TX90 XL	N/A	N/A		
Robot Remote Control	Stäubli	CS8C	N/A	N/A		
DASY5 Measurement Server	SPEAG	SEUMS001BA	1041	N/A		
Probe Alignment Unit	SPEAG	LB (V2)	261	N/A		
Data Acquisition Electronics	SPEAG	DAE4	1257	10	25	2012
Radio Communication Tester	R & S	CMU 200	1005296	6	24	2012
E-Field Probe	SPEAG	ER3DV6	2339	1	20	2013
H-Field Probe	SPEAG	H3DV6	6157	1	30	2013
Calibration Dipole	SPEAG	CD835V3	1014	3	8	2013
Calibration Dipole	SPEAG	CD1880V3	1122	3	8	2013
Amplifier	MITEQ	4D00400600-50-30P	1620606	N/A		
Directional coupler	Werlatone	C8060-102	2141	N/A		

4.2. Measurement Uncertainty

HAC Uncertainty Budget According to ANSI PC63.19

Error Description	Uncertainty value ($\pm\%$)	Probe Dist.	Div.	(Ci) E	(Ci) H	Std. Unc.($\pm\%$)	
						E	H
Measurement System							
Probe Calibration	5.10	N	1	1	1	5.1	5.1
Axial Isotropy	4.70	R	1.732	1	1	2.7	2.7
Sensor Displacement	16.50	R	1.732	1	0.145	9.5	1.4
Boundary Effects	2.40	R	1.732	1	1	1.4	1.4
Linearity	4.70	R	1.732	1	1	2.7	2.7
Scaling to Peak Envelope Power	2.00	R	1.732	1	1	1.2	1.2
System Detection Limit	1.00	R	1.732	1	1	0.6	0.6
Readout Electronics	0.30	N	1	1	1	0.3	0.3
Response Time	0.80	R	1.732	1	1	0.5	0.5
Integration Time	2.60	R	1.732	1	1	1.5	1.5
RF Ambient Conditions	3.00	R	1.732	1	1	1.7	1.7
RF Reflections	12.00	R	1.732	1	1	6.9	6.9
Probe Positioner	1.20	R	1.732	1	0.67	0.7	0.5
Probe Positioning	4.70	R	1.732	1	0.67	2.7	1.8
Extrapolation and Interpolation	1.00	R	1.732	1	1	0.6	0.6
Test sample Related							
Test Positioning Vertical	4.70	R	1.732	1	0.67	2.7	1.8
Test Positioning Lateral	1.00	R	1.732	1	1	0.6	0.6
Device Holder and Phantom	2.40	R	1.732	1	1	1.4	1.4
Power Drift	5.00	R	1.732	1	1	2.9	2.9
Phantom and Setup Related							
Phantom Thickness	2.40	R	1.732	1	0.67	1.4	0.9
Combined Std. Uncertainty						14.7	10.9
Expanded Std. Uncertainty on Power						29.4	21.8
Expanded Std. Uncertainty on Field						14.7	10.9
Notes for table							
1. N - Nomal							
2. R - Rectangular							
3. Div. - Divisor used to obtain standard uncertainty							
4. Ci - is te sensitivity coefficient							

5. Equipment Under Test

Cellular/PCS CDMA/GSM/WCDMA & LTE Phone w/ BT & WLAN + NFC	
Model: ZNFVS930	
Normal operation:	Held to head
Accessory:	1. Standard cover 2. Wireless Charging Battery Cover

5.1. List of Air Interfaces/Bands & Operating Modes

Air-Interface	Bands (MHz)	Type	C63.19/ Tested	Simultaneous Transmissions Note: Not to be tested	Concurrent single transmission	Reduced power 20.19 (c) (1)	Voice Over Digital Transport (Data)
GSM	850	VO	Yes	Yes: WiFi and Bluetooth	Yes: GPRS/EDGE, LTE, WiFi and Bluetooth	N/A	N/A
	1900		Yes				
	GPRS/EDGE	DT	N/A	N/A	Yes: * see note	N/A	N/A
CDMA	800	VO	Yes	Yes LTE, EV-DO, WiFi and Bluetooth	Yes: EV-DO, LTE, WiFi and Bluetooth	N/A	N/A
	1900		Yes				
	EV-DO	DT	N/A	N/A	Yes: * see note	Yes: **SVDO mode only	Yes
LTE	Band 13	DT	N/A	Yes EV-DO, WiFi and Bluetooth	Yes: * see note	Yes: **SVLTE mode only	Yes
W-CDMA	Band II R 99	VO	Yes	Yes WiFi or Bluetooth	Yes: HSPA, WiFi and Bluetooth	N/A	N/A
	HSPA	DT	N/A	N/A	Yes: * see note	N/A	Yes
WiFi	2450	DT	N/A	Yes CDMA,GSM,W-CDMA, LTE, EV-DO and Bluetooth	N/A	N/A	Yes
	5000	DT	N/A	N/A	N/A	N/A	Yes
Bluetooth	2400	DT	N/A	Yes CDMA,GSM,W-CDMA, LTE, EV-DO and WiFi	N/A	N/A	N/A
VO Voice CMRS/PTSN Service Only V/D Voice CMRS/PSTN and Data Service DT Digital Transport				Note: * HAC Rating was not base on concurrent voice and data modes, Noncurrent mode was found to represent worst case rating. For M rating Note: ** SVDO: CDMA voice and EVDO Simultaneously transmission SVLTE: CDMA voice and LTE Simultaneously transmission			

6. System Specifications

E-field and H-field measurements are performed using the DASY5 automated dosimetric assessment system. The DASY5 is made by Schmid & Partner Engineering AG (SPEAG) in Zurich, Switzerland.

The DASY5 HAC Extension consists of the following parts:

Test Arch Phantom

The specially designed Test Arch allows high precision positioning of both the device and any of the validation dipoles.

ER3DV6 Isotropic E-Field Probe

Construction:	One dipole parallel, two dipoles normal to probe axis Built-in shielding against static charges PEEK enclosure material (resistant to organic solvents, e.g., glycoether)
Calibration:	In air from 100 MHz to 3.0 GHz (absolute accuracy $\pm 6.0\%$, $k=2$)
Frequency:	100 MHz to > 6 GHz; Linearity: ± 0.2 dB (100 MHz to 3 GHz)
Directivity:	± 0.2 dB in air (rotation around probe axis) ± 0.4 dB in air (rotation normal to probe axis)
Dynamic Range:	2 V/m to > 1000 V/m; Linearity: ± 0.2 dB
Dimensions:	Overall length: 330 mm (Tip: 16 mm) Tip diameter: 8 mm (Body: 12 mm) Distance from probe tip to dipole centers: 2.5 mm The closest part of the sensor element is 1.1 mm closer to the tip
Application:	General near-field measurements up to 6 GHz Field component measurements

H3DV6 3-Dimensional H-Field Probe

Construction:	Three concentric loop sensors with 3.8 mm loop diameters resistively loaded detector diodes for linear response Built-in shielding against static charges PEEK enclosure material (resistant to organic solvents, e.g., glycoether)
Frequency:	200 MHz to 3 GHz (absolute accuracy $\pm 6.0\%$, $k=2$); Output linearized
Directivity:	± 0.25 dB (spherical isotropy error)
Dynamic Range:	10 mA/m to 2 A/m at 1 GHz
E-Field Interference:	< 10% at 3 GHz (for plane wave)
Dimensions:	Overall length: 330 mm (Tip: 40 mm) Tip diameter: 6 mm (Body: 12 mm) Distance from probe tip to dipole centers: 3 mm The closest part of the sensor element is 1.9 mm closer to the tip
Application:	General magnetic near-field measurements up to 3 GHz Field component measurements Surface current measurements Measurements in air or liquids Low interaction with the measured field

7. System Validation

The test setup was validated when first configured and verified periodically thereafter to ensure proper function. The procedure provided in this section is a validation procedure using dipole antennas for which the field levels were computed by numeric modeling.

Procedure

Place a dipole antenna meeting the requirements given in ANSI-PC63.19 2007 in the normally occupied by the WD.

The dipole antenna serves as a known source for an electrical and magnetic output. Position the E-field and H-field probes so that:

- The probes and their cables are parallel to the coaxial feed of the dipole antenna
- The probe cables and the coaxial feed of the dipole antenna approach the measurement area from opposite directions; and
- The center point of the probe element(s) are 10 mm from the closest surface of the dipole elements.

Scan the length of the dipole with both E-field and H-field probes and record the maximum values for each. Compare the readings to expected values.

Setup diagram

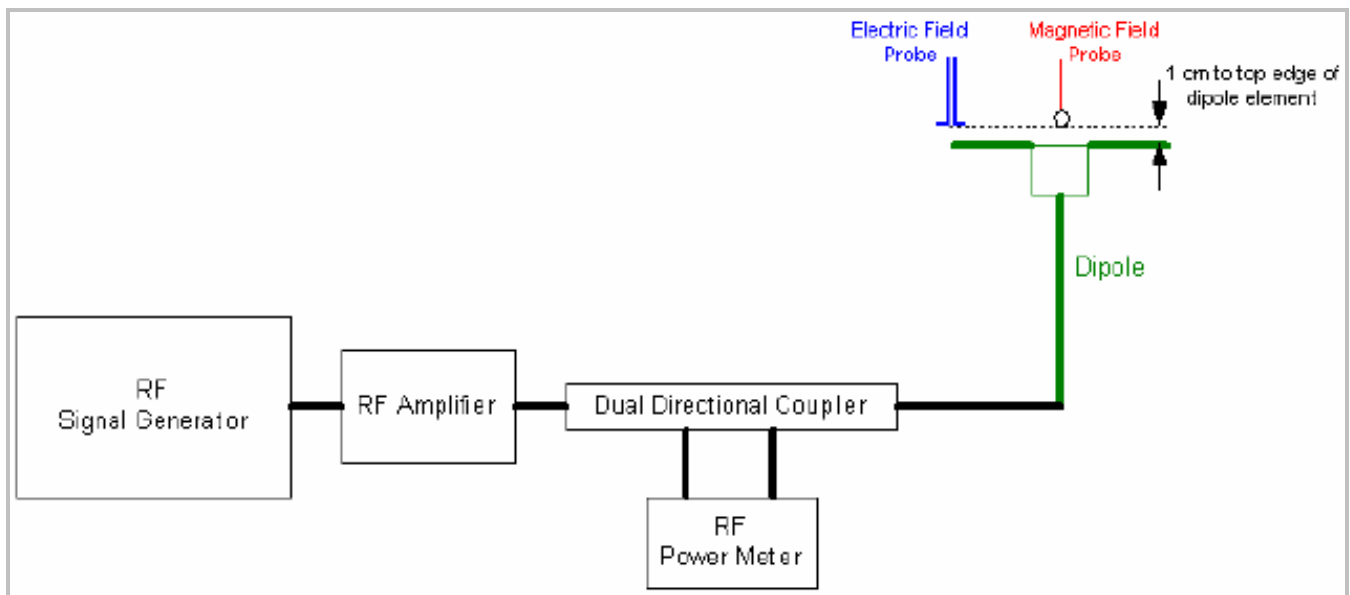

7.1. System Validation Results

E-field

Calibration Dipole	f (MHz)	Input Power (mW)	Max. measured from		Average max. above arm (V/m)	E-field Target Values (V/m) (From SPEAG)	Deviation ¹⁾ (%)
			above high end (V/m)	above low end (V/m)			
CD835V3 SN 1014	835	100	159.2	154.9	157.05	171.0	-8.16
CD1880V3 SN 1122	1880	100	148.4	148.3	148.35	140.3	5.74

H-field

Calibration Dipole	f (MHz)	Input Power (mW)	Measured H-field (A/m)	H-field Target Values (A/m) (From SPEAG)	Deviation ¹⁾ (%)
CD835V3 SN 1014	835	100	0.460	0.475	-3.16
CD1880V3 SN 1122	1880	100	0.470	0.464	1.29

Notes:

- 1) Delta (Deviation) % = 100 * (Measured value minus Target value) divided by the Target value. Deltas within ±25% are acceptable, of which 12% is deviation and 13% is measurement uncertainty.
- 2) The maximum E-field or H-field were evaluated and compared to the target values provided by SPEAG in the calibration certificate of specific dipoles.
- 3) Please refer to the attachment for detailed measurement data and plots.

8. Probe Modulation Factor (PMF)

Purpose

The HAC Standard requires measurement of the peak envelope E- and H-fields of the wireless device (WD). Para. 4.2.2.1, and C.3.1 of the standard describes the Probe Modulation Response Factor that shall be applied to convert the probe reading to Peak Envelope Field.

Definitions

The Probe Modulation Factor (PMF) is defined as the ratio of the field readings for a CW and a modulated signal with the equivalent Field Envelope Peak as defined in the Standard (Chapter C.3.1).

Evaluation Procedure for Unknown PMF (DASY4 Application note, Section 28.8)

The proposed measurement setup corresponds to the procedure as required in the Standard, Chapter C.3.1.

1. Install a calibration dipole for the appropriate frequency band under the Test Arch Phantom and select the proper phantom section according to the probe type installed (E- or H-field). Move the probe to the field reference point. (Do not move the probe between the subsequent CW and modulated measurements.)
2. Install the field probe in the setup.
3. The modulated signal to the dipole must be monitored to record peak amplitude and compared to a CW signal with the same peak envelope level (e.g., with a directional coupler and a spectrum analyzer in zero span mode set to the operating frequency). To determine the peak envelope level of the modulated signal properly, the settings of a spectrum analyzer shall be as follows:
 - Resolution bandwidth \geq emission bandwidth (4 MHz for UMTS bands, 300 kHz)
 - Video bandwidth \geq 20 kHz
 - Span: zero
 - Center Frequency: nominal center frequency of channel
 - Detection: RMS detection with averaging turned on
 - Trigger: Video or IF trigger, adjusted to give a stable display of the transmission
 - Sweep rate: Sufficiently rapid to permit the transmit pulse to be resolved accurately. The sweep shall be long enough to show a complete transmission. The sweep time may be set to allow a full transmission cycle, displaying the on and off time.
4. Define a DASY4 document and set the procedure properties (frequency, modulation frequency and crest factor) according to the measured signal. Define a multimeter job for the field reading.
5. Define a second procedure for the evaluation of the CW signal (frequency set as above, modulation frequency = 0, crest factor = 1) and a multimeter job.

PMF Measurement Setup Diagram

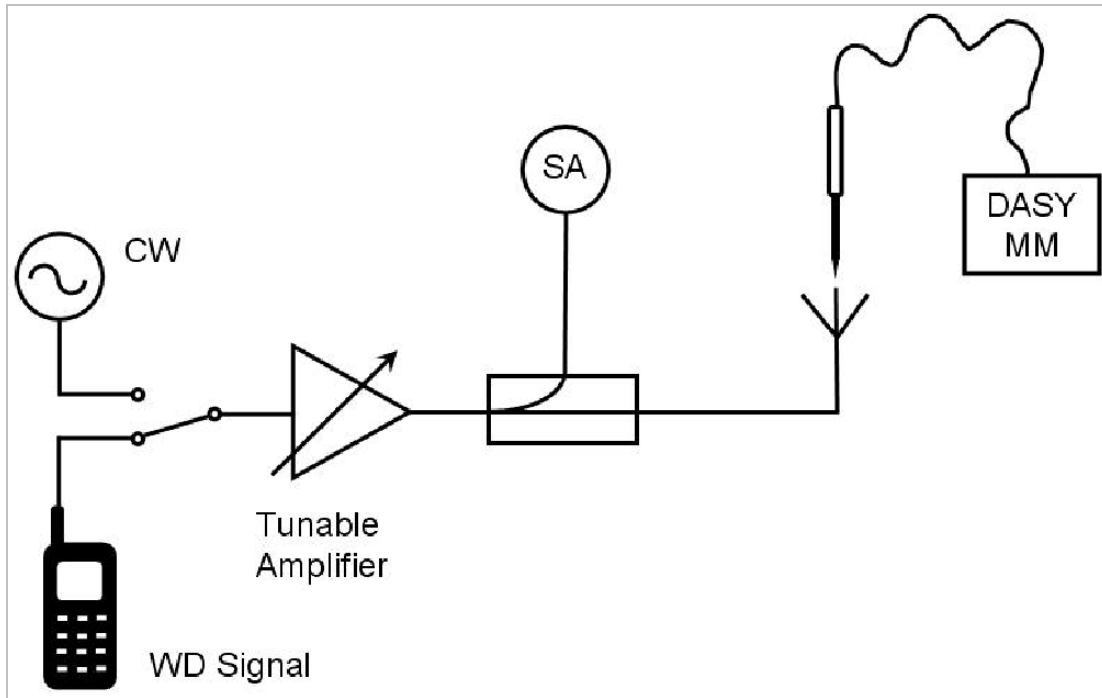

The HAC measurement procedure is as follows:

- a) Modulated signals (WD and 80% AM) measurement:
 - 1) Connect the modulated signal using the appropriate frequency via the cable to the dipole.
 - 2) The signal to the dipole must be monitored to record peak amplitude with a directional coupler and a spectrum analyzer.
 - 3) Run the multimeter job in the procedure with the corresponding modulation setting in continuous mode.
 - 4) Read the envelope peak on the monitor in order to adjust the CW signal later to the same level.
- b) CW signal measurement:
 - 1) Change the signal to CW at the same center frequency, without touching or moving the dipole and probe in the setup.
 - 2) Adjust the CW signal amplitude to the same peak level on the spectrum analyzer (keep the same bandwidth and attenuation for CW and modulated signals).
 - 3) Run the multimeter job in the CW procedure in continuous mode.
 - 4) Read the multimeter total field display and note it together with modulation type and frequency.
 - 5) Calculate the Probe Modulation Factor as the ratio between the CW multimeter field reading and the reading for the applicable modulation. I.e., $PMF = \frac{E_{cw}}{E_{mod}}$ and similar for H.

8.1. PMF Measurement Results

GSM

Probe	Frequency (MHz)	Type of signal	E-field V/m	PMF
E-Field Probe	835	GSM	54.4	2.79
		CW	152.0	
	1880	GSM	29.8	2.82
		CW	83.9	
Probe	Frequency (MHz)	Type of signal	H-field A/m	PMF
H-Field Probe	835	GSM	0.144	2.79
		CW	0.402	
	1880	GSM	0.132	2.84
		CW	0.375	

W-CDMA

Probe	Frequency (MHz)	Type of signal	E-field V/m	PMF
E-Field Probe	835	UMTS	49.66	0.89
		CW	44.30	
	1880	UMTS	36.90	0.96
		CW	35.30	
Probe	Frequency (MHz)	Type of signal	H-field A/m	PMF
H-Field Probe	835	UMTS	0.144	0.90
		CW	0.129	
	1880	UMTS	0.128	0.95
		CW	0.122	

CDMA

Probe	Frequency (MHz)	Type of signal	E-field V/m	PMF
E-Field Probe	835	CDMA (RC3/SO55)	64.6	0.95
		CW	61.4	
	1880	CDMA (RC3/SO55)	44.7	0.95
		CW	42.6	
Probe	Frequency (MHz)	Type of signal	H-field A/m	PMF
H-Field Probe	835	CDMA (RC3/SO55)	0.260	0.96
		CW	0.249	
	1880	CDMA (RC3/SO55)	0.190	0.98
		CW	0.187	

9. HAC RF Emissions Test Procedure

The following are step-by-step test procedures.

1. Confirm proper operation of the field probe, probe measurement system and other instrumentation and the positioning system.
2. Position the WD in its intended test position.
3. Configure the WD normal operation for maximum rated RF output power, at the desired channel and other operating parameters, (e.g. test mode) as intended for the test.
4. The center sub-grid shall be centered on the center of the WD output (acoustic or T-coil output), as appropriate. Locate the field probe at the initial test position in the 5 x 5 cm grid, which is contained in the measurement plane, see illustrated in Figure 5.
5. Record the reading.
6. Scan the entire 5 x 5 cm region in equally spaced increments and record the reading at each measurement point. The distance between measurement points shall be sufficient to assure the identification of the peak reading.
7. Identify the five contiguous sub-grids around the center sub-grid with the lowest maximum strength readings. Thus the 6 areas to be used to determine the WD's peak emissions are identified and outlined for the final manual scan. Please note that a maximum of five blocks can be excluded for both E- and H-field measurements for the WD output being measured. State another way, the center sub-grid and 3 other must be common to both the E- and H-field measurements.
8. Identify the highest field reading within the non-excluded sub-grids identified in step 7.
9. Convert the highest field reading within identified in step 8 to peak V/m or A/m, as appropriate.
10. Repeat steps 1-10 for both the E- and H-field measurements.
11. Compare this reading to the categories in ANSI-PC63.19 and record the resulting category. The lowest category number listed in ANSI-PC63.19 obtained in step 10 for either E or H field determines the M category for the audio coupling mode assessment. Record the WD category rating.

Test flowchart Per ANSI-PC63.19 2007

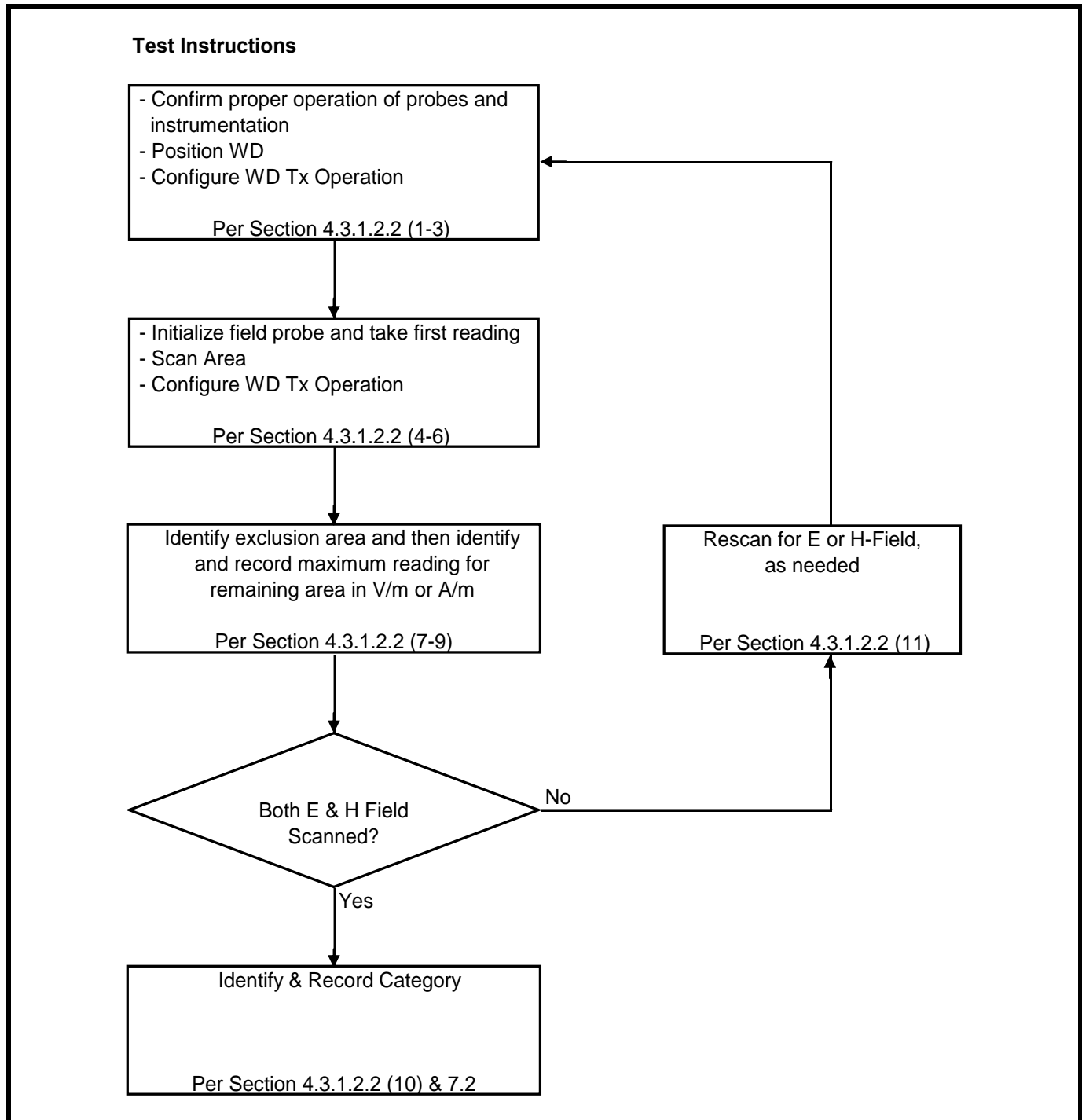

10. RF Emissions Measurement Criteria

Telephone near-field Categories in linear units

		Telephone RF Parameters			
		< 960 MHz		> 960 MHz	
Category	AWF	E-Field Emissions (V/m)	H-Field Emissions (A/m)	E-Field Emissions (V/m)	H-Field Emissions (A/m)
M3	0	199.5 to 354.8	0.60 to 1.07	63.1 to 112.2	0.19 to 0.34
	-5	149.6 to 266.1	0.45 to 0.80	47.3 to 84.1	0.14 to 0.25
M4	0	< 199.5	< 0.60	< 63.1	< 0.19
	-5	< 149.6	< 0.45	< 47.3	< 0.14

11. HAC (RF Emissions) Test Results

11.1. E-Field Emissions

Standard cover

Operating Mode	Ch. No.	f (MHz)	PMF	Peak E-Field (V/m)	M-Rating
GSM850	128	824.2	2.79	145.9	M4
	190	836.6		144.6	M4
	251	848.8		136.3	M4
GSM1900	512	1850.2	2.82	48.875	M3
	661	1880.0		48.393	M3
	810	1909.8		51.522	M3
W-CDMA band II R99 RMC 12.2kbps	9262	1852.4	0.96	18.537	M4
	9400	1880.0		21.627	M4
	9538	1907.6		26.599	M4
CDMA BC0 1xRTT (RC3, SO55)	1013	824.70	0.95	55.962	M4
	384	836.52		55.090	M4
	777	848.31		54.087	M4
CDMA BC1 1xRTT (RC3, SO55)	25	1851.25	0.95	22.190	M4
	600	1880.00		21.699	M4
	1175	1908.75		22.411	M4

Wireless Charging Battery Cover

Operating Mode	Ch. No.	f (MHz)	PMF	Peak E-Field (V/m)	M-Rating
GSM850	128	824.2	2.79	154.6	M3
	190	836.6		151.0	M3
	251	848.8		141.3	M4
GSM1900	512	1850.2	2.82	46.380	M4
	661	1880.0		46.929	M4
	810	1909.8		50.327	M3
W-CDMA band II R99 RMC 12.2kbps	9262	1852.4	0.96	17.671	M4
	9400	1880.0		19.983	M4
	9538	1907.6		24.151	M4
CDMA BC0 1xRTT (RC3, SO55)	1013	824.70	0.95	54.861	M4
	384	836.52		52.818	M4
	777	848.31		51.828	M4
CDMA BC1 1xRTT (RC3, SO55)	25	1851.25	0.95	21.406	M4
	600	1880.00		22.148	M4
	1175	1908.75		21.983	M4

11.2. H-Field Emissions

Standard cover

Operating Mode	Ch. No.	f (MHz)	PMF	Peak H-Field (A/m)	M-Rating
GSM850	128	824.2	2.79	0.232	M4
	190	836.6		0.228	M4
	251	848.8		0.201	M4
GSM1900	512	1850.2	2.84	0.143	M3
	661	1880.0		0.142	M3
	810	1909.8		0.155	M3
W-CDMA band II R99 RMC 12.2kbps	9262	1852.4	0.95	0.054	M4
	9400	1880.0		0.060	M4
	9538	1907.6		0.074	M4
CDMA BC0 1xRTT (RC3, SO55)	1013	824.70	0.96	0.094	M4
	384	836.52		0.088	M4
	777	848.31		0.083	M4
CDMA BC1 1xRTT (RC3, SO55)	25	1851.25	0.98	0.066	M4
	600	1880.00		0.070	M4
	1175	1908.75		0.069	M4

Wireless Charging Battery Cover

Operating Mode	Ch. No.	f (MHz)	PMF	Peak H-Field (A/m)	M-Rating
GSM850	128	824.2	2.79	0.233	M4
	190	836.6		0.225	M4
	251	848.8		0.205	M4
GSM1900	512	1850.2	2.84	0.137	M4
	661	1880.0		0.138	M4
	810	1909.8		0.149	M3
W-CDMA band II R99 RMC 12.2kbps	9262	1852.4	0.95	0.052	M4
	9400	1880.0		0.059	M4
	9538	1907.6		0.070	M4
CDMA BC0 1xRTT (RC3, SO55)	1013	824.70	0.96	0.088	M4
	384	836.52		0.084	M4
	777	848.31		0.080	M4
CDMA BC1 1xRTT (RC3, SO55)	25	1851.25	0.98	0.064	M4
	600	1880.00		0.067	M4
	1175	1908.75		0.067	M4

12. Worst-case Test Plots

E-field worst-cast test plot for Part 22

Date: 6/6/2012

Test Laboratory: UL CCS SAR Lab C

GSM 850 with Wireless Charging Battery Cover

Communication System: GPRS-FDD (TDMA, GMSK, 1 slot); Frequency: 824.4 MHz; Duty Cycle: 1:8.00018

Phantom section: RF Section

DASY4 Configuration:

- Probe: ER3DV6 - SN2339; ConvF(1, 1, 1); Calibrated: 1/20/2012
- Sensor-Surface: (Fix Surface)
- Electronics: DAE4 Sn1257; Calibrated: 10/25/2011
- Phantom: HAC Test Arch with AMCC; Type: SD HAC P01 BB
- Measurement SW: DASY52, Version 52.8 (0); SEMCAD X Version 14.4.5 (3634)

E-Field/L ch/Hearing Aid Compatibility Test (101x101x1): Measurement grid: dx=5mm, dy=5mm

Maximum value of peak Total field = 154.6 V/m

Probe Modulation Factor = 2.790

Device Reference Point: 0, 0, -6.3 mm

Reference Value = 71.633 V/m; Power Drift = -0.02 dB

Hearing Aid Near-Field Category: M3 (AWF -5 dB)

Peak E-field in V/m

Grid 1 147.1 M4	Grid 2 153.9 M3	Grid 3 147.2 M4
Grid 4 143.2 M4	Grid 5 154.6 M3	Grid 6 148.8 M4
Grid 7 136.2 M4	Grid 8 148.8 M4	Grid 9 143.2 M4

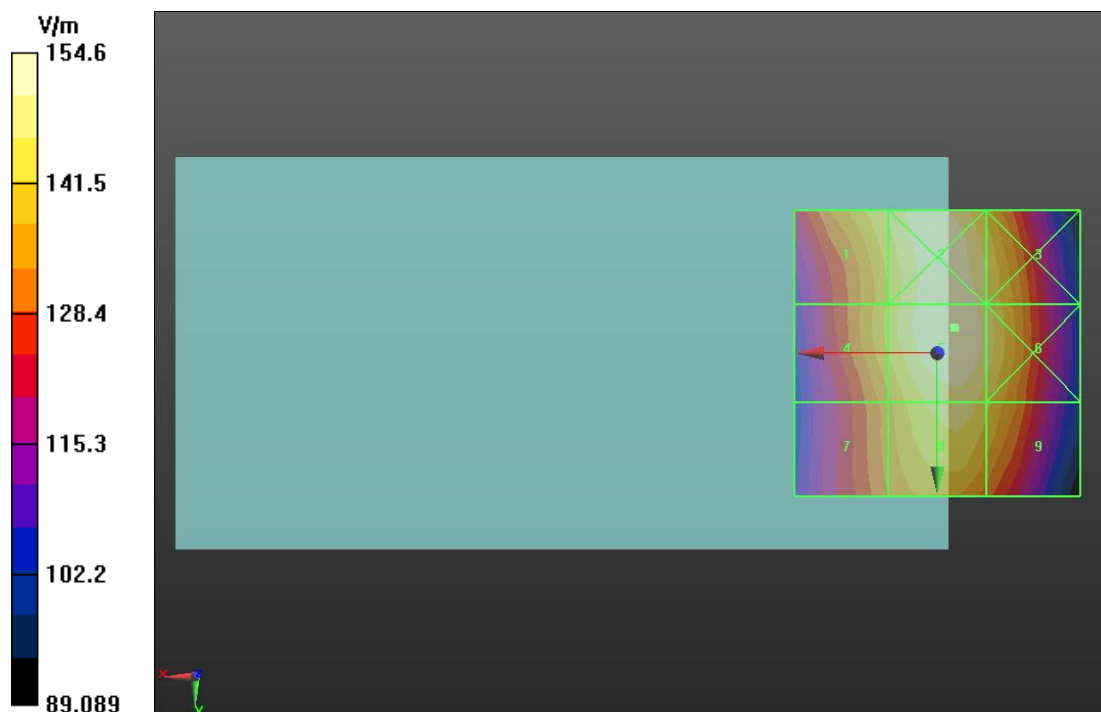

E-field worst-cast test plot for Part 24

Date: 6/6/2012

Test Laboratory: UL CCS SAR Lab C

GSM 1900 with Wireless Charging Battery Cover

Communication System: GPRS-FDD (TDMA, GMSK, 1 slot); Frequency: 1909.8 MHz; Duty Cycle: 1:8.00018
 Phantom section: RF Section
 DASY4 Configuration:
 - Probe: ER3DV6 - SN2339; ConvF(1, 1, 1); Calibrated: 1/20/2012
 - Sensor-Surface: (Fix Surface)
 - Electronics: DAE4 Sn1257; Calibrated: 10/25/2011
 - Phantom: HAC Test Arch with AMCC; Type: SD HAC P01 BB
 - Measurement SW: DASY52, Version 52.8 (0);SEMCAD X Version 14.4.5 (3634)

E-Field/H ch/Hearing Aid Compatibility Test (101x101x1): Measurement grid: dx=5mm, dy=5mm
 Maximum value of peak Total field = 50.327 V/m
 Probe Modulation Factor = 2.820
 Device Reference Point: 0, 0, -6.3 mm
 Reference Value = 20.176 V/m; Power Drift = 0.0044 dB
Hearing Aid Near-Field Category: M3 (AWF -5 dB)

Peak E-field in V/m

Grid 1 38.283 M4	Grid 2 50.327 M3	Grid 3 50.215 M3
Grid 4 39.490 M4	Grid 5 48.699 M3	Grid 6 48.695 M3
Grid 7 54.016 M3	Grid 8 52.787 M3	Grid 9 49.691 M3

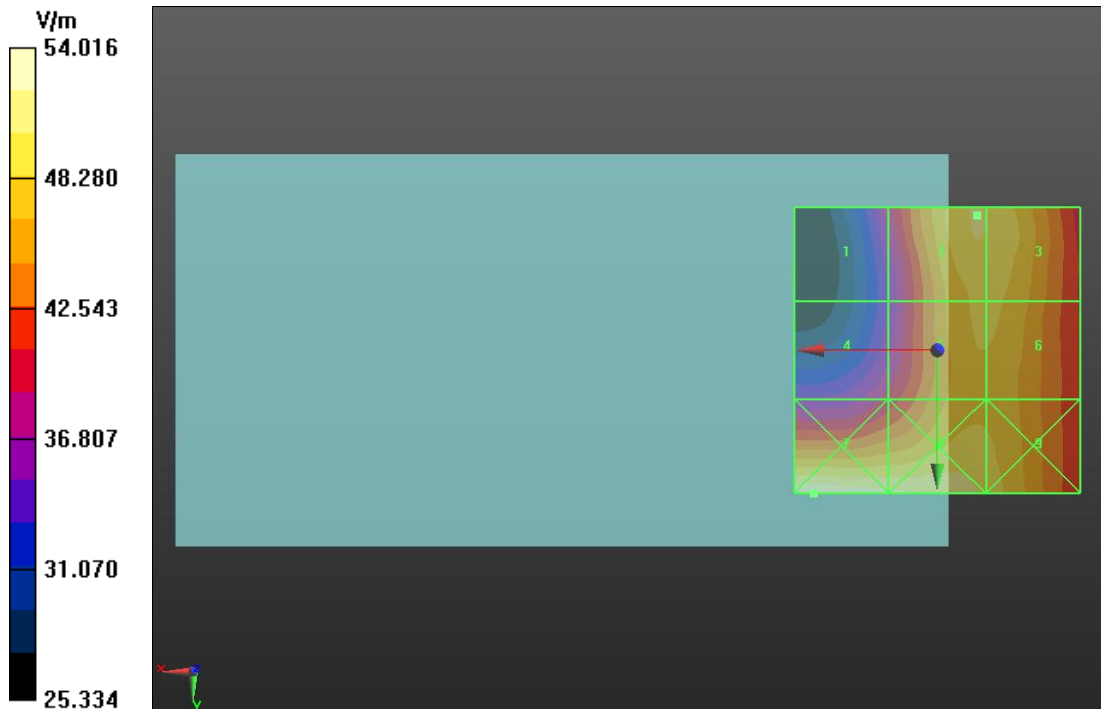

H-field worst-cast test plot for Part 22

Date: 6/6/2012

Test Laboratory: UL CCS SAR Lab C

GSM 850 with Wireless Charging Battery Cover

Communication System: GPRS-FDD (TDMA, GMSK, 1 slot); Frequency: 824.4 MHz; Duty Cycle: 1:8.00018

Phantom section: RF Section

DASY4 Configuration:

- Probe: H3DV6 - SN6157; ; Calibrated: 1/30/2012
- Sensor-Surface: (Fix Surface)
- Electronics: DAE4 Sn1257; Calibrated: 10/25/2011
- Phantom: HAC Test Arch with AMCC; Type: SD HAC P01 BB
- Measurement SW: DASY52, Version 52.8 (0);SEMCAD X Version 14.4.5 (3634)

H-Field/L ch/Hearing Aid Compatibility Test (101x101x1): Measurement grid: dx=5mm, dy=5mm

Maximum value of peak Total field = 0.233 A/m

Probe Modulation Factor = 2.790

Device Reference Point: 0, 0, -6.3 mm

Reference Value = 0.060 A/m; Power Drift = 0.06 dB

Hearing Aid Near-Field Category: M4 (AWF -5 dB)

Peak H-field in A/m

Grid 1 0.270 M4	Grid 2 0.192 M4	Grid 3 0.121 M4
Grid 4 0.278 M4	Grid 5 0.211 M4	Grid 6 0.134 M4
Grid 7 0.314 M4	Grid 8 0.233 M4	Grid 9 0.143 M4

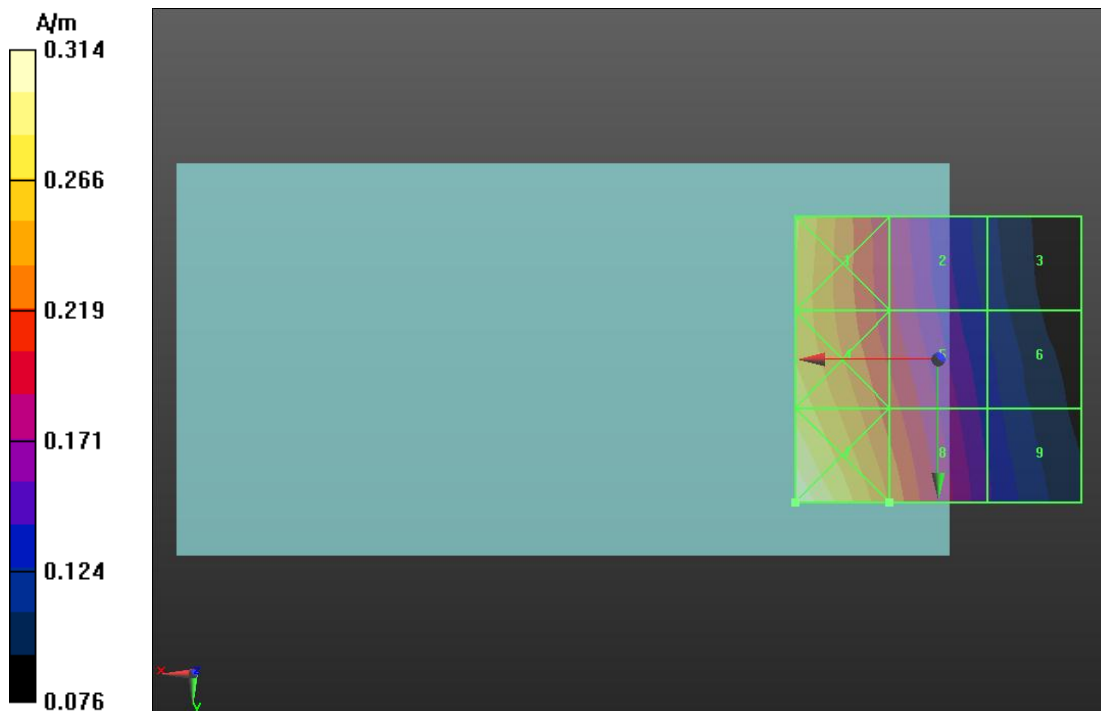

H-field worst-cast test plot for Part 24

Date: 6/6/2012

Test Laboratory: UL CCS SAR Lab C

GSM 1900 with Standard cover

Communication System: GPRS-FDD (TDMA, GMSK, 1 slot); Frequency: 1909.8 MHz; Duty Cycle: 1:8.00018
 Phantom section: RF Section
 DASY4 Configuration:
 - Probe: H3DV6 - SN6157; ; Calibrated: 1/30/2012
 - Sensor-Surface: (Fix Surface)
 - Electronics: DAE4 Sn1257; Calibrated: 10/25/2011
 - Phantom: HAC Test Arch with AMCC; Type: SD HAC P01 BB
 - Measurement SW: DASY52, Version 52.8 (0);SEMCAD X Version 14.4.5 (3634)

H-Field/H ch/Hearing Aid Compatibility Test (101x101x1): Measurement grid: dx=5mm, dy=5mm
 Maximum value of peak Total field = 0.155 A/m
 Probe Modulation Factor = 2.840
 Device Reference Point: 0, 0, -6.3 mm
 Reference Value = 0.053 A/m; Power Drift = -0.0073 dB
Hearing Aid Near-Field Category: M3 (AWF -5 dB)

Peak H-field in A/m

Grid 1 0.149 M3	Grid 2 0.135 M4	Grid 3 0.110 M4
Grid 4 0.155 M3	Grid 5 0.155 M3	Grid 6 0.130 M4
Grid 7 0.200 M3	Grid 8 0.173 M3	Grid 9 0.136 M4

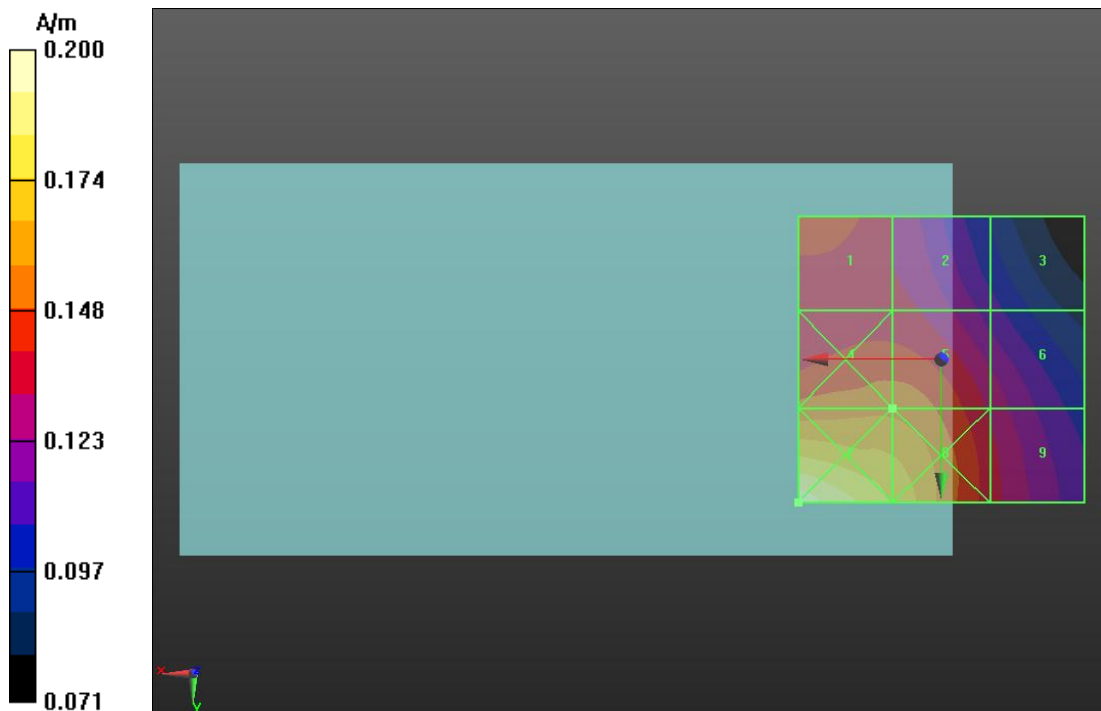

13. Appendixes

Refer to separated files for the following appendixes

- 13.1. System Validation Plots**
- 13.2. E-field emissions test plots**
- 13.3. H-field emissions test plots**
- 13.4. Calibration Certificate - E-Field Probe ER3DV6 - SN 2339**
- 13.5. Calibration Certificate - H-Field Probe H3DV6 - SN 6157**
- 13.6. Calibration Certificate for Dipole CD835V3 - SN 1014**
- 13.7. Calibration Certificate for Dipole CD1880V3 - SN 1122**