



SAR EVALUATION REPORT

Applicant Name:
 LG Electronics MobileComm U.S.A., Inc.
 1000 Sylvan Avenue
 Englewood Cliffs, NJ 07632
 United States

Date of Testing:
 06/02/14 - 06/04/14
Test Site/Location:
 PCTEST Lab, Columbia, MD, USA
Document Serial No.:
 0Y1406021127.ZNF

FCC ID:	ZNFVK410
APPLICANT:	LG ELECTRONICS MOBILECOMM U.S.A., INC.

DUT Type: Portable Tablet
Application Type: Certification
FCC Rule Part(s): CFR §2.1093
Model(s): LG-VK410, VK410, LGVK410

Equipment Class	Band & Mode	Tx Frequency	SAR
			1 gm Body (W/kg)
TNB	LTE Band 13	782 MHz	0.71
TNB	LTE Band 4 (AWS)	1712.5 - 1752.5 MHz	0.77
DTS	2.4 GHz WLAN	2412 - 2462 MHz	0.43
DTS	5.8 GHz WLAN	5745 - 5825 MHz	0.21
NII	5.2 GHz WLAN	5180 - 5240 MHz	0.63
NII	5.3 GHz WLAN	5260 - 5320 MHz	0.65
NII	5.5 GHz WLAN	5500 - 5700 MHz	0.42
DSS/DTS	Bluetooth	2402 - 2480 MHz	N/A
Simultaneous SAR per KDB 690783 D01v01r02:			1.26

This wireless portable device has been shown to be capable of compliance for localized specific absorption rate (SAR) for uncontrolled environment/general population exposure limits specified in ANSI/IEEE C95.1-1992 and has been tested in accordance with the measurement procedures specified in Section 1.7 of this report; for North American frequency bands only.

I attest to the accuracy of data. All measurements reported herein were performed by me or were made under my supervision and are correct to the best of my knowledge and belief. I assume full responsibility for the completeness of these measurements and vouch for the qualifications of all persons taking them. Test results reported herein relate only to the item(s) tested.

 Randy Ortanez
 President







FCC ID: ZNFVK410		SAR EVALUATION REPORT		Reviewed by: Quality Manager
Document S/N: 0Y1406021127.ZNF	Test Dates: 06/02/14 - 06/04/14	DUT Type: Portable Tablet	Page 1 of 47	

TABLE OF CONTENTS

1	DEVICE UNDER TEST	3
2	LTE INFORMATION	8
3	INTRODUCTION	9
4	DOSIMETRIC ASSESSMENT	10
5	SAR TESTING PROCEDURES	11
6	RF EXPOSURE LIMITS	12
7	FCC MEASUREMENT PROCEDURES.....	13
8	RF CONDUCTED POWERS.....	16
9	SYSTEM VERIFICATION.....	29
10	SAR DATA SUMMARY	31
11	FCC MULTI-TX AND ANTENNA SAR CONSIDERATIONS.....	34
12	SAR MEASUREMENT VARIABILITY	41
13	EQUIPMENT LIST.....	42
14	MEASUREMENT UNCERTAINTIES	43
15	CONCLUSION.....	45
16	REFERENCES	46
APPENDIX A: SAR TEST PLOTS		
APPENDIX B: SAR DIPOLE VERIFICATION PLOTS		
APPENDIX C: PROBE AND DIPOLE CALIBRATION CERTIFICATES		
APPENDIX D: SAR TISSUE SPECIFICATIONS		
APPENDIX E: SAR SYSTEM VALIDATION		
APPENDIX F: SAR TEST SETUP PHOTOGRAPHS		
APPENDIX G: SENSOR TRIGGERING DATA SUMMARY		

FCC ID: ZNFVK410	 PCTEST ENGINEERING LABORATORY, INC.	SAR EVALUATION REPORT	 LG	Reviewed by: Quality Manager
Document S/N: OY1406021127.ZNF	Test Dates: 06/02/14 - 06/04/14	DUT Type: Portable Tablet		Page 2 of 47

1 DEVICE UNDER TEST



1.1 Device Overview

Band & Mode	Operating Modes	Tx Frequency
LTE Band 13	Data	782 MHz
LTE Band 4 (AWS)	Data	1712.5 - 1752.5 MHz
2.4 GHz WLAN	Data	2412 - 2462 MHz
5.8 GHz WLAN	Data	5745 - 5825 MHz
5.2 GHz WLAN	Data	5180 - 5240 MHz
5.3 GHz WLAN	Data	5260 - 5320 MHz
5.5 GHz WLAN	Data	5500 - 5700 MHz
Bluetooth	Data	2402 - 2480 MHz

1.2 Power Reduction for SAR

This device uses a sensor for SAR compliance. The sensor is activated when used in close proximity to the user's body. The sensor triggers power reduction for data modes and is only applicable for tablet operations.

Since the device is a full size tablet, the Body SAR was evaluated per FCC KDB Publication 616217 D04 for full sized tablets.

FCC ID: ZNFVK410	 PCTEST ENGINEERING LABORATORY, INC.	SAR EVALUATION REPORT	 LG	Reviewed by: Quality Manager
Document S/N: 0Y1406021127.ZNF	Test Dates: 06/02/14 - 06/04/14	DUT Type: Portable Tablet	Page 3 of 47	

1.3 Nominal and Maximum Output Power Specifications

This device operates using the following maximum and nominal output power specifications. SAR values were scaled to the maximum allowed power to determine compliance per KDB Publication 447498 D01v05.



1.3.1 Maximum Power

Mode / Band		Modulated Average (dBm)
LTE Band 13	Maximum	24.2
	Nominal	23.7
LTE Band 4 (AWS)	Maximum	24.2
	Nominal	23.7

Mode / Band		Modulated Average (dBm)
IEEE 802.11b (2.4 GHz)	Maximum	12.5
	Nominal	11.5
IEEE 802.11g (2.4 GHz)	Maximum	9.0
	Nominal	8.0
IEEE 802.11n (2.4 GHz)	Maximum	8.0
	Nominal	7.0
IEEE 802.11a (5 GHz)	Maximum	11.0
	Nominal	10.0
IEEE 802.11n (5 GHz) (20 Mhz and 40 MHz BW)	Maximum	10.0
	Nominal	9.0
Bluetooth	Maximum	9.0
	Nominal	8.0
Bluetooth LE	Maximum	6.0
	Nominal	5.0

1.3.2 Reduced Power (Body at 0mm)

Mode / Band		Modulated Average (dBm)
LTE Band 13	Maximum	20.2
	Nominal	19.7
LTE Band 4 (AWS)	Maximum	14.2
	Nominal	13.7

FCC ID: ZNFVK410	 PCTEST ENGINEERING LABORATORY, INC.	SAR EVALUATION REPORT	 LG	Reviewed by: Quality Manager
Document S/N: OY1406021127.ZNF	Test Dates: 06/02/14 - 06/04/14	DUT Type: Portable Tablet	Page 4 of 47	

1.4 DUT Antenna Locations

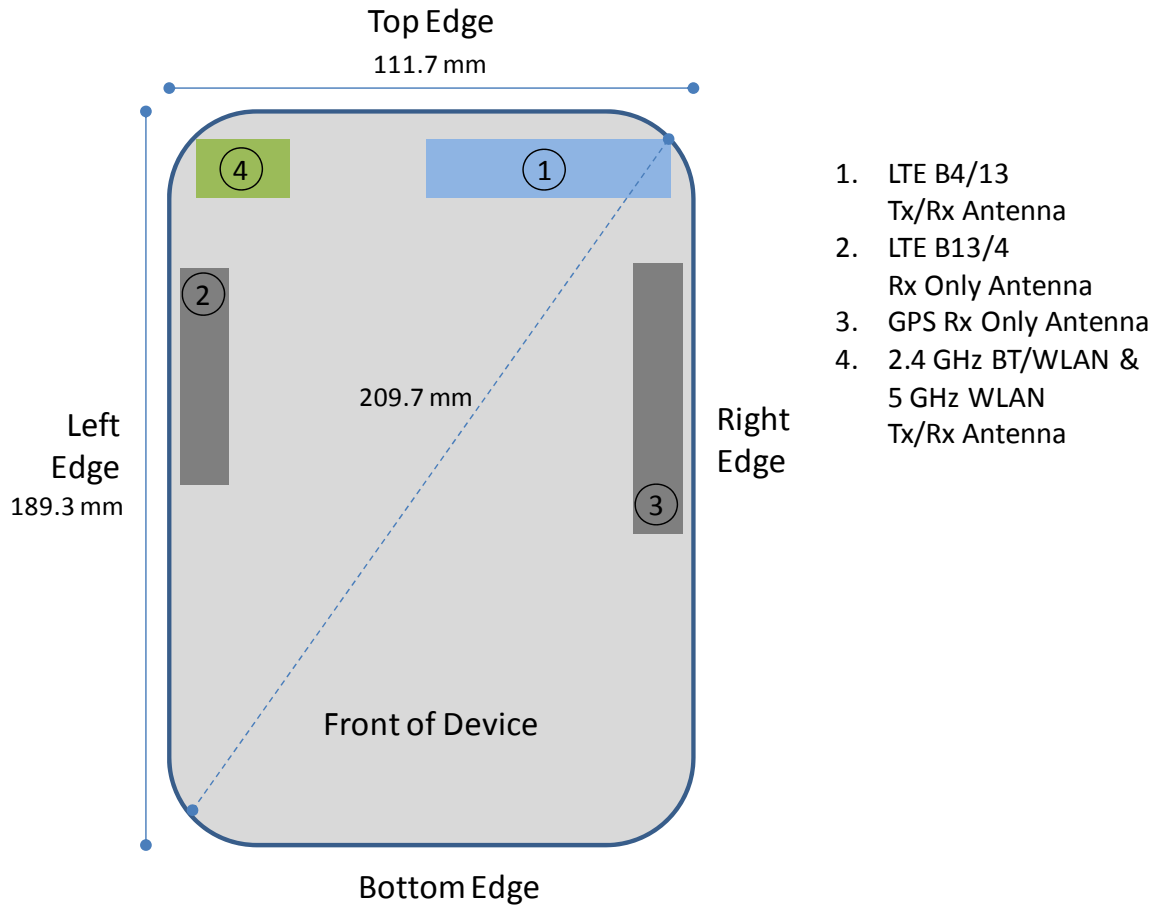



Figure 1-1
DUT Antenna Locations

Note: Exact antenna dimensions and separation distances are shown in the Technical Descriptions in the FCC Filing.

Table 1-1
Sides for SAR Testing

Mode	Back	Front	Top	Bottom	Right	Left
LTE Band 13	Yes	No	Yes	No	Yes	Yes
LTE Band 4 (AWS)	Yes	No	Yes	No	Yes	Yes
2.4 GHz WLAN	Yes	No	Yes	No	No	Yes
5 GHz WLAN	Yes	No	Yes	No	No	Yes

Note: Per FCC KDB 616217 D04v01r01, Particular DUT edges were not required to be evaluated for SAR based on the SAR exclusion threshold in KDB 447498 D01v05r01.

FCC ID: ZNFVK410		SAR EVALUATION REPORT		Reviewed by: Quality Manager
Document S/N: OY1406021127.ZNF	Test Dates: 06/02/14 - 06/04/14	DUT Type: Portable Tablet		Page 5 of 47

1.5 Simultaneous Transmission Capabilities

According to FCC KDB Publication 447498 D05v01, transmitters are considered to be transmitting simultaneously when there is overlapping transmission, with the exception of transmissions during network hand-offs with maximum hand-off duration less than 30 seconds. Possible transmission paths for the DUT are shown in Figure 1-2 and are color-coded to indicate communication modes which share the same path. Modes which share the same transmission path cannot transmit simultaneously with one another.

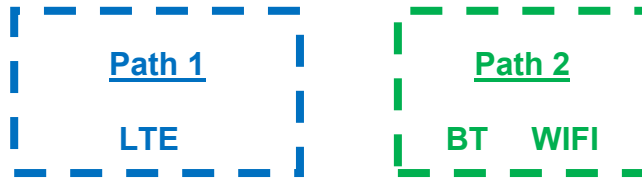

Figure 1-2
Simultaneous Transmission Paths

This device contains multiple transmitters that may operate simultaneously, and therefore requires a simultaneous transmission analysis according to FCC KDB Publication 447498 D01v05 3) procedures.

Table 1-2
Simultaneous Transmission Scenarios

No.	Capable Transmit Configuration	Body
1	LTE + 2.4 GHz WI-FI	Yes
2	LTE + 5 GHz WI-FI	Yes
3	LTE + 2.4 GHz Bluetooth	Yes

Notes:

1. 2.4 GHz WI-FI, 2.4 GHz Bluetooth, and 5 GHz WI-FI share the same antenna path and cannot transmit simultaneously.

1.6 SAR Test Exclusions Applied



(A) WIFI/BT

Per FCC KDB 447498 D01v05, the SAR exclusion threshold for distances <50mm is defined by the following equation:

$$\frac{\text{Max Power of Channel (mW)}}{\text{Test Separation Dist (mm)}} * \sqrt{\text{Frequency(GHz)}} \leq 3.0$$

Based on the maximum conducted power of Bluetooth (rounded to the nearest mW) and the antenna to user separation distance, Bluetooth SAR was not required; $[(8/5) * \sqrt{2.441}] = 2.5 < 3.0$. Per KDB Publication 447498 D01v05, the maximum power of the channel was rounded to the nearest mW before calculation.

This device supports 20 MHz and 40 MHz Bandwidths for IEEE 802.11n for 5 GHz WIFI only. IEEE 802.11n was not evaluated for SAR since the average output power of 20 MHz and 40 MHz bandwidths was not more than 0.25 dB higher than the average output power of IEEE 802.11a.

FCC ID: ZNFVK410		SAR EVALUATION REPORT		Reviewed by: Quality Manager
Document S/N: OY1406021127.ZNF	Test Dates: 06/02/14 - 06/04/14	DUT Type: Portable Tablet		Page 6 of 47

(B) Licensed Transmitter(s)

LTE SAR for the higher modulations and lower bandwidths were not tested since the maximum average output power of all required channels and configurations was not more than 0.5 dB higher than the highest bandwidth; and the reported LTE SAR for the highest bandwidth was less than 1.45 W/kg for all configurations according to FCC KDB 941225 D05v02.



1.7 Guidance Applied

- FCC KDB Publication 941225 D01v02r02, D02v02r02, D05v02r03 (4G)
- FCC KDB Publication 248227 D01v01r02 (SAR Considerations for 802.11 Devices)
- FCC KDB Publication 447498 D01v05 (General SAR Guidance)
- FCC KDB Publication 865664 D01-D02 (SAR Measurements up to 6 GHz)
- FCC KDB Publication 616217 D04 (Tablet SAR Considerations)

1.8 Device Serial Numbers

Several samples with identical hardware were used to support SAR testing. The manufacturer has confirmed that the device(s) tested have the same physical, mechanical and thermal characteristics and are within operational tolerances expected for production units.



	Maximum Power Serial Number	Reduced Power Serial Number
LTE Band 13	0206-4	0206-5
LTE Band 4 (AWS)	0206-4	0206-5
2.4 GHz WLAN	0206-11	-
5 GHz WLAN	0206-11	-

FCC ID: ZNFVK410	 PCTEST ENGINEERING LABORATORY, INC.	SAR EVALUATION REPORT	 LG	Reviewed by: Quality Manager
Document S/N: OY1406021127.ZNF	Test Dates: 06/02/14 - 06/04/14	DUT Type: Portable Tablet	Page 7 of 47	

2

LTE INFORMATION

LTE Information			
FCC ID	ZNFVK410		
Form Factor	Portable Tablet		
Frequency Range of each LTE transmission band	LTE Band 13 (782 MHz)		
	LTE Band 4 (AWS) (1712.5 - 1752.5 MHz)		
Channel Bandwidths	LTE Band 13: 10 MHz		
	LTE Band 4 (AWS): 5 MHz, 10 MHz, 15 MHz, 20 MHz		
Channel Numbers and Frequencies (MHz)	Low	Mid	High
LTE Band 13: 10 MHz	782 (23230)	782 (23230)	782 (23230)
LTE Band 4 (AWS): 5 MHz	1712.5 (19975)	1732.5 (20175)	1752.5 (20375)
LTE Band 4 (AWS): 10 MHz	1715 (20000)	1732.5 (20175)	1750 (20350)
LTE Band 4 (AWS): 15 MHz	1717.5 (20025)	1732.5 (20175)	1747.5 (20325)
LTE Band 4 (AWS): 20 MHz	1720 (20050)	1732.5 (20175)	1745 (20300)
UE Category	3		
Modulations Supported in UL	QPSK, 16QAM		
LTE MPR Permanently implemented per 3GPP TS 36.101 section 6.2.3~6.2.5? (manufacturer attestation to be provided)	YES		
A-MPR (Additional MPR) disabled for SAR Testing?	YES		

FCC ID: ZNFVK410	 PCTEST ENGINEERING LABORATORY, INC.	SAR EVALUATION REPORT	 LG	Reviewed by: Quality Manager
Document S/N: OY1406021127.ZNF	Test Dates: 06/02/14 - 06/04/14	DUT Type: Portable Tablet		Page 8 of 47

3 INTRODUCTION

The FCC and Industry Canada have adopted the guidelines for evaluating the environmental effects of radio frequency (RF) radiation in ET Docket 93-62 on Aug. 6, 1996 and Health Canada Safety Code 6 to protect the public and workers from the potential hazards of RF emissions due to FCC-regulated portable devices. [1]

The safety limits used for the environmental evaluation measurements are based on the criteria published by the American National Standards Institute (ANSI) for localized specific absorption rate (SAR) in IEEE/ANSI C95.1-1992 Standard for Safety Levels with Respect to Human Exposure to Radio Frequency Electromagnetic Fields, 3 kHz to 300 GHz [3] and Health Canada RF Exposure Guidelines Safety Code 6 [22]. The measurement procedure described in IEEE/ANSI C95.3-2002 Recommended Practice for the Measurement of Potentially Hazardous Electromagnetic Fields - RF and Microwave [4] is used for guidance in measuring the Specific Absorption Rate (SAR) due to the RF radiation exposure from the Equipment Under Test (EUT). These criteria for SAR evaluation are similar to those recommended by the International Committee for Non-Ionizing Radiation Protection (ICNIRP) in Biological Effects and Exposure Criteria for Radiofrequency Electromagnetic Fields,” Report No. Vol 74. SAR is a measure of the rate of energy absorption due to exposure to an RF transmitting source. SAR values have been related to threshold levels for potential biological hazards.

3.1 SAR Definition

Specific Absorption Rate is defined as the time derivative (rate) of the incremental energy (dU) absorbed by (dissipated in) an incremental mass (dm) contained in a volume element (dV) of a given density (ρ). It is also defined as the rate of RF energy absorption per unit mass at a point in an absorbing body (see Equation 3-1).

Equation 3-1
SAR Mathematical Equation

$$SAR = \frac{d}{dt} \left(\frac{dU}{dm} \right) = \frac{d}{dt} \left(\frac{dU}{\rho dv} \right)$$



SAR is expressed in units of Watts per Kilogram (W/kg).

$$SAR = \frac{\sigma \cdot E^2}{\rho}$$

where:

- σ = conductivity of the tissue-simulating material (S/m)
- ρ = mass density of the tissue-simulating material (kg/m³)
- E = Total RMS electric field strength (V/m)

NOTE: The primary factors that control rate of energy absorption were found to be the wavelength of the incident field in relation to the dimensions and geometry of the irradiated organism, the orientation of the organism in relation to the polarity of field vectors, the presence of reflecting surfaces, and whether conductive contact is made by the organism with a ground plane.[6]

FCC ID: ZNFVK410	 <small>PCTEST ENGINEERING LABORATORY, INC.</small>	SAR EVALUATION REPORT		Reviewed by: Quality Manager
Document S/N: OY1406021127.ZNF	Test Dates: 06/02/14 - 06/04/14	DUT Type: Portable Tablet	Page 9 of 47	

4 DOSIMETRIC ASSESSMENT

4.1 Measurement Procedure

The evaluation was performed using the following procedure compliant to FCC KDB Publication 865664 D01v01 and IEEE 1528-2013:

1. The SAR distribution at the exposed side of the head or body was measured at a distance no greater than 5.0 mm from the inner surface of the shell. The area covered the entire dimension of the device-head and body interface and the horizontal grid resolution was determined per FCC KDB Publication 865664 D01v01 (See Table 4-1) and IEEE 1528-2013.
2. The point SAR measurement was taken at the maximum SAR region determined from Step 1 to enable the monitoring of SAR fluctuations/drifts during the 1g/10g cube evaluation. SAR at this fixed point was measured and used as a reference value.
3. Based on the area scan data, the peak of the region with maximum SAR was determined by spline interpolation. Around this point, a volume was assessed according to the measurement resolution and volume size requirements of FCC KDB Publication 865664 D01v01 (See Table 4-1) and IEEE 1528-2013. On the basis of this data set, the spatial peak SAR value was evaluated with the following procedure (see references or the DASY manual online for more details):
 - a. SAR values at the inner surface of the phantom are extrapolated from the measured values along the line away from the surface with spacing no greater than that in Table 4-1. The extrapolation was based on a least-squares algorithm. A polynomial of the fourth order was calculated through the points in the z-axis (normal to the phantom shell).
 - b. After the maximum interpolated values were calculated between the points in the cube, the SAR was averaged over the spatial volume (1g or 10g) using a 3D-Spline interpolation algorithm. The 3D-spline is composed of three one-dimensional splines with the “Not a knot” condition (in x, y, and z directions). The volume was then integrated with the trapezoidal algorithm. One thousand points (10 x 10 x 10) were obtained through interpolation, in order to calculate the averaged SAR.
 - c. All neighboring volumes were evaluated until no neighboring volume with a higher average value was found.
4. The SAR reference value, at the same location as step 2, was re-measured after the zoom scan was complete to calculate the SAR drift. If the drift deviated by more than 5%, the SAR test and drift measurements were repeated.

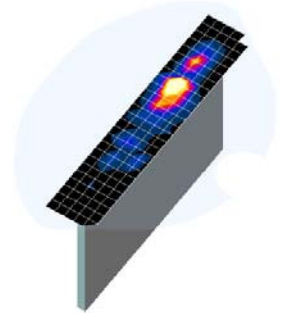

Figure 4-1
Sample SAR Area Scan

Table 4-1
Area and Zoom Scan Resolutions per FCC KDB Publication 865664 D01v01*

Frequency	Maximum Area Scan Resolution (mm) ($\Delta x_{\text{area}}, \Delta y_{\text{area}}$)	Maximum Zoom Scan Resolution (mm) ($\Delta x_{\text{zoom}}, \Delta y_{\text{zoom}}$)	Maximum Zoom Scan Spatial Resolution (mm)			Minimum Zoom Scan Volume (mm) (x,y,z)
			Uniform Grid	Graded Grid		
			$\Delta z_{\text{zoom}}(n)$	$\Delta z_{\text{zoom}}(1)^*$	$\Delta z_{\text{zoom}}(n>1)^*$	
≤ 2 GHz	≤ 15	≤ 8	≤ 5	≤ 4	≤ 1.5* $\Delta z_{\text{zoom}}(n-1)$	≥ 30
2-3 GHz	≤ 12	≤ 5	≤ 5	≤ 4	≤ 1.5* $\Delta z_{\text{zoom}}(n-1)$	≥ 30
3-4 GHz	≤ 12	≤ 5	≤ 4	≤ 3	≤ 1.5* $\Delta z_{\text{zoom}}(n-1)$	≥ 28
4-5 GHz	≤ 10	≤ 4	≤ 3	≤ 2.5	≤ 1.5* $\Delta z_{\text{zoom}}(n-1)$	≥ 25
5-6 GHz	≤ 10	≤ 4	≤ 2	≤ 2	≤ 1.5* $\Delta z_{\text{zoom}}(n-1)$	≥ 22

*Also compliant to IEEE 1528-2013 Table 6

FCC ID: ZNFVK410	SAR EVALUATION REPORT		Reviewed by: Quality Manager
Document S/N: OY1406021127.ZNF	Test Dates: 06/02/14 - 06/04/14	DUT Type: Portable Tablet	Page 10 of 47

5 SAR TESTING PROCEDURES

5.1 SAR Testing for Tablet per KDB Publication 616217 D04v01

This device can be used in full sized tablet exposure conditions, due to its size. Per FCC KDB 616217, the back surface and edges of the tablet should be tested for SAR compliance with the tablet touching the phantom. The SAR Exclusion Threshold in KDB 447498 D01v05 can be applied to determine SAR test exclusion for adjacent edge configurations. The closest distance from the antenna to an adjacent tablet edge is used to determine if SAR testing is required for the adjacent edges, with the adjacent edge positioned against the phantom and the edge containing the antenna positioned perpendicular to the phantom.



5.2 Proximity Sensor Considerations

This device uses a proximity sensor to reduce data powers in tablet-device use conditions.

While the device's antenna is within a certain distance of the user, the sensor activates and reduces the maximum output power allowed. However, the sensor is not active when the device is moved beyond the sensor triggering distance and the maximum output power is no longer limited. Therefore, an additional exposure condition is needed in the vicinity of the triggering distance to ensure SAR is compliant when the device is allowed to operate at a non-reduced output power level.

FCC KDB 616217 D04 Section 6 was used as a guideline for selecting SAR test distances for this device at these additional exposure conditions. Since the sensor activation distance for the back side of the device is 15 mm, a conservative distance of 14 mm was tested for SAR on the back side at maximum power. Since the sensor activation distance for the top edge of the device is 17 mm, a conservative distance of 16 mm was tested for SAR on the top edge at maximum power. Since the sensor activation distance for the right edge of the device is 8 mm, a conservative distance of 7 mm was tested for SAR on the right edge at maximum power. Sensor triggering distance summary data is included in Appendix G. The sensor does not trigger power reduction from the front of the device.

The sensor is designed to support sufficient detection range and sensitivity to cover regions of the sensors in all applicable directions since the sensor entirely covers the antenna.

FCC ID: ZNFVK410		SAR EVALUATION REPORT		Reviewed by: Quality Manager
Document S/N: OY1406021127.ZNF	Test Dates: 06/02/14 - 06/04/14	DUT Type: Portable Tablet	Page 11 of 47	

6 RF EXPOSURE LIMITS

6.1 Uncontrolled Environment

UNCONTROLLED ENVIRONMENTS are defined as locations where there is the exposure of individuals who have no knowledge or control of their exposure. The general population/uncontrolled exposure limits are applicable to situations in which the general public may be exposed or in which persons who are exposed as a consequence of their employment may not be made fully aware of the potential for exposure or cannot exercise control over their exposure. Members of the general public would come under this category when exposure is not employment-related; for example, in the case of a wireless transmitter that exposes persons in its vicinity.



6.2 Controlled Environment

CONTROLLED ENVIRONMENTS are defined as locations where there is exposure that may be incurred by persons who are aware of the potential for exposure, (i.e. as a result of employment or occupation). In general, occupational/controlled exposure limits are applicable to situations in which persons are exposed as a consequence of their employment, who have been made fully aware of the potential for exposure and can exercise control over their exposure. This exposure category is also applicable when the exposure is of a transient nature due to incidental passage through a location where the exposure levels may be higher than the general population/uncontrolled limits, but the exposed person is fully aware of the potential for exposure and can exercise control over his or her exposure by leaving the area or by some other appropriate means.

Table 6-1
SAR Human Exposure Specified in ANSI/IEEE C95.1-1992 and Health Canada Safety Code 6

HUMAN EXPOSURE LIMITS		
	UNCONTROLLED ENVIRONMENT <i>General Population</i> (W/kg) or (mW/g)	CONTROLLED ENVIRONMENT <i>Occupational</i> (W/kg) or (mW/g)
Peak Spatial Average SAR Head	1.6	8.0
Whole Body SAR	0.08	0.4
Peak Spatial Average SAR Hands, Feet, Ankle, Wrists, etc.	4.0	20

1. The Spatial Peak value of the SAR averaged over any 1 gram of tissue (defined as a tissue volume in the shape of a cube) and over the appropriate averaging time.
2. The Spatial Average value of the SAR averaged over the whole body.
3. The Spatial Peak value of the SAR averaged over any 10 grams of tissue (defined as a tissue volume in the shape of a cube) and over the appropriate averaging time.

FCC ID: ZNFVK410	 PCTEST ENGINEERING LABORATORY, INC.	SAR EVALUATION REPORT	 LG	Reviewed by: Quality Manager
Document S/N: OY1406021127.ZNF	Test Dates: 06/02/14 - 06/04/14	DUT Type: Portable Tablet		Page 12 of 47

7 FCC MEASUREMENT PROCEDURES

Power measurements were performed using a base station simulator under digital average power.

7.1 Measured and Reported SAR

Per FCC KDB Publication 447498 D01v05, When SAR is not measured at the maximum power level allowed for production units, the results must be scaled to the maximum tune-up tolerance limit according to the power applied to the individual channels tested to determine compliance. For simultaneous transmission, the measured aggregate SAR must be scaled according to the sum of the differences between the maximum tune-up tolerance and actual power used to test each transmitter. When SAR is measured at or scaled to the maximum tune-up tolerance limit, the results are referred to as *reported* SAR. The highest *reported* SAR results are identified on the grant of equipment authorization according to procedures in KDB 690783 D01v01r02.

7.2 Procedures Used to Establish RF Signal for SAR

The following procedures are according to FCC KDB Publication 941225 D01 "SAR Measurement Procedures for 3G Devices" v02, October 2007.

The device was placed into a simulated call using a base station simulator in a RF shielded chamber. Establishing connections in this manner ensure a consistent means for testing SAR and are recommended for evaluating SAR [4]. Devices under test were evaluated prior to testing, with a fully charged battery and were configured to operate at maximum output power. In order to verify that the device was tested throughout the SAR test at maximum output power, the SAR measurement system measures a "point SAR" at an arbitrary reference point at the start and end of the 1 gram SAR evaluation, to assess for any power drifts during the evaluation. If the power drift deviated by more than 5%, the SAR test and drift measurements were repeated.

7.3 SAR Measurement Conditions for LTE

LTE modes were tested according to FCC KDB 941225 D05v02 publication. Please see notes after the tabulated SAR data for required test configurations. Establishing connections with base station simulators ensure a consistent means for testing SAR and are recommended for evaluating SAR [4]. The R&S CMW500 was used for LTE output power measurements and SAR testing. Closed loop power control was used so the UE transmits with maximum output power during SAR testing. SAR tests were performed with the same number of RB and RB offsets transmitting on all TTI frames (maximum TTI).

7.3.1 Spectrum Plots for RB Configurations



A properly configured base station simulator was used for SAR tests and power measurements. Therefore, spectrum plots for RB configurations were not required to be included in this report.

7.3.2 MPR

MPR is permanently implemented for this device by the manufacturer. The specific manufacturer target MPR is indicated alongside the SAR results. MPR is enabled for this device, according to 3GPP TS36.101 Section 6.2.3 – 6.2.5 under Table 6.2.3-1.

7.3.3 A-MPR

A-MPR (Additional MPR) has been disabled for all SAR tests by setting NS=01 on the base station simulator.

FCC ID: ZNFVK410	 PCTEST ENGINEERING LABORATORY, INC.	SAR EVALUATION REPORT	 LG	Reviewed by: Quality Manager
Document S/N: OY1406021127.ZNF	Test Dates: 06/02/14 - 06/04/14	DUT Type: Portable Tablet		Page 13 of 47

7.3.4 Required RB Size and RB Offsets for SAR Testing

According to FCC KDB 941225 D05v02r01:



- a. Per Section 5.2.1, SAR is required for QPSK 1 RB Allocation for the largest bandwidth
 - i. The required channel and offset combination with the highest maximum output power is required for SAR.
 - ii. When the reported SAR is ≤ 0.8 W/kg, testing of the remaining RB offset configurations and required test channels is not required. Otherwise, SAR is required for the remaining required test channels using the RB offset configuration with highest output power for that channel.
 - iii. When the reported SAR for a required test channel is > 1.45 W/kg, SAR is required for all RB offset configurations for that channel.
- b. Per Section 5.2.2, SAR is required for 50% RB allocation using the largest bandwidth following the same procedures outlined in Section 5.2.1.
- c. Per Section 5.2.3, QPSK SAR is not required for the 100% allocation when the highest maximum output power for the 100% allocation is less than the highest maximum output power of the 1 RB and 50% RB allocations and the reported SAR for the 1 RB and 50% RB allocations is < 0.8 W/kg.
- d. Per Section 5.2.4 and 5.3, SAR tests for higher order modulations and lower bandwidths configurations are not required when the conducted power of the required test configurations determined by Sections 5.2.1 through 5.2.3 is less than or equal to $\frac{1}{2}$ dB higher than the equivalent configuration using QPSK modulation and when the QPSK SAR for those configurations is < 1.45 W/kg.

7.4 SAR Testing with 802.11 Transmitters

Normal network operating configurations are not suitable for measuring the SAR of 802.11 a/b/g/n transmitters. Unpredictable fluctuations in network traffic and antenna diversity conditions can introduce undesirable variations in SAR results. The SAR for these devices should be measured using chipset based test mode software to ensure the results are consistent and reliable. See KDB Publication 248227 D01v01r02 for more details.

7.4.1 General Device Setup

Chipset based test mode software is hardware dependent and generally varies among manufacturers. The device operating parameters established in test mode for SAR measurements must be identical to those programmed in production units, including output power levels, amplifier gain settings and other RF performance tuning parameters. The test frequencies should correspond to actual channel frequencies defined for domestic use. SAR for devices with switched diversity should be measured with only one antenna transmitting at a time during each SAR measurement, according to a fixed modulation and data rate. The same data pattern should be used for all measurements.



FCC ID: ZNFVK410	 PCTEST ENGINEERING LABORATORY, INC.	SAR EVALUATION REPORT	 LG	Reviewed by: Quality Manager
Document S/N: OY1406021127.ZNF	Test Dates: 06/02/14 - 06/04/14	DUT Type: Portable Tablet	Page 14 of 47	

7.4.2 Frequency Channel Configurations [24]

For 2.4 GHz, the highest average RF output power channel between the low, mid and high channel at the lowest data rate was selected for SAR evaluation in 802.11b mode. 802.11g/n modes and higher data rates for 802.11b were additionally evaluated for SAR if the output power of the respective mode was 0.25 dB or higher than the powers of the SAR configurations tested in the 802.11b mode.

For 5 GHz, the highest average RF output power channel across the default test channels at the lowest data rate was selected for SAR evaluation in 802.11a. When the adjacent channels are higher in power than the default channels, these “required channels” were considered instead of the default channels for SAR testing. 802.11n modes and higher data rates for 802.11a/n were evaluated only if the respective mode was higher than 0.25 dB or more than the 802.11a mode.

If the maximum extrapolated peak SAR of the zoom scan for the highest output channel was less than 1.6 W/kg and if the 1g averaged SAR was less than 0.8 W/kg, SAR testing was not required for the other test channels in the band.

FCC ID: ZNFVK410		SAR EVALUATION REPORT		Reviewed by: Quality Manager
Document S/N: 0Y1406021127.ZNF	Test Dates: 06/02/14 - 06/04/14	DUT Type: Portable Tablet		Page 15 of 47

8 RF CONDUCTED POWERS

8.1 LTE Conducted Powers



8.1.1 LTE Band 13

Table 8-1
LTE Band 13 Conducted Powers – 10 MHz Bandwidth
Maximum Power

	Frequency [MHz]	Channel	Bandwidth [MHz]	Modulation	RB Size	RB Offset	Conducted Power [dBm]	MPR Allowed per 3GPP [dB]	MPR [dB]
Mid	782.0	23230	10	QPSK	1	0	24.19	0	0
	782.0	23230	10	QPSK	1	25	24.04	0	0
	782.0	23230	10	QPSK	1	49	24.14	0	0
	782.0	23230	10	QPSK	25	0	23.12	0-1	1
	782.0	23230	10	QPSK	25	12	23.13	0-1	1
	782.0	23230	10	QPSK	25	25	23.09	0-1	1
	782.0	23230	10	QPSK	50	0	23.10	0-1	1
	782.0	23230	10	16QAM	1	0	23.17	0-1	1
	782.0	23230	10	16QAM	1	25	23.19	0-1	1
	782.0	23230	10	16QAM	1	49	23.13	0-1	1
	782.0	23230	10	16QAM	25	0	22.09	0-2	2
	782.0	23230	10	16QAM	25	12	22.14	0-2	2
	782.0	23230	10	16QAM	25	25	22.16	0-2	2
	782.0	23230	10	16QAM	50	0	22.10	0-2	2

Table 8-2
LTE Band 13 Conducted Powers - 10 MHz Bandwidth
Reduced Power – Body at 0 mm

	Frequency [MHz]	Channel	Bandwidth [MHz]	Modulation	RB Size	RB Offset	Conducted Power [dBm]	MPR Allowed per 3GPP [dB]	MPR [dB]
Mid	782.0	23230	10	QPSK	1	0	20.05	0	0
	782.0	23230	10	QPSK	1	25	20.15	0	0
	782.0	23230	10	QPSK	1	49	20.17	0	0
	782.0	23230	10	QPSK	25	0	20.08	0-1	0
	782.0	23230	10	QPSK	25	12	20.14	0-1	0
	782.0	23230	10	QPSK	25	25	20.09	0-1	0
	782.0	23230	10	QPSK	50	0	19.91	0-1	0
	782.0	23230	10	16QAM	1	0	19.98	0-1	0
	782.0	23230	10	16QAM	1	25	20.01	0-1	0
	782.0	23230	10	16QAM	1	49	19.91	0-1	0
	782.0	23230	10	16QAM	25	0	19.94	0-2	0
	782.0	23230	10	16QAM	25	12	20.05	0-2	0
	782.0	23230	10	16QAM	25	25	19.85	0-2	0
	782.0	23230	10	16QAM	50	0	19.94	0-2	0

FCC ID: ZNFVK410	 PCTEST <small>ENGINEERING LABORATORY, INC.</small>	SAR EVALUATION REPORT	 LG	Reviewed by: Quality Manager
Document S/N: OY1406021127.ZNF	Test Dates: 06/02/14 - 06/04/14	DUT Type: Portable Tablet		Page 16 of 47

8.1.2 LTE Band 4 (AWS)

Table 8-3
LTE Band 4 (AWS) Conducted Powers – 20 MHz Bandwidth
Maximum Power

	Frequency [MHz]	Channel	Bandwidth [MHz]	Modulation	RB Size	RB Offset	Conducted Power [dBm]	MPR Allowed per 3GPP [dB]	MPR [dB]
Mid	1732.5	20175	20	QPSK	1	0	24.15	0	0
	1732.5	20175	20	QPSK	1	50	24.09	0	0
	1732.5	20175	20	QPSK	1	99	24.10	0	0
	1732.5	20175	20	QPSK	50	0	22.95	0-1	1
	1732.5	20175	20	QPSK	50	25	23.07	0-1	1
	1732.5	20175	20	QPSK	50	50	23.08	0-1	1
	1732.5	20175	20	QPSK	100	0	23.01	0-1	1
	1732.5	20175	20	16QAM	1	0	23.03	0-1	1
	1732.5	20175	20	16QAM	1	50	22.97	0-1	1
	1732.5	20175	20	16QAM	1	99	23.04	0-1	1
	1732.5	20175	20	16QAM	50	0	22.13	0-2	2
	1732.5	20175	20	16QAM	50	25	22.08	0-2	2
	1732.5	20175	20	16QAM	50	50	22.08	0-2	2
1732.5	20175	20	16QAM	100	0	22.12	0-2	2	

Note: LTE Band 4 (AWS) at 10 MHz bandwidth does not support three non-overlapping channels. Per KDB Publication 941225 D05v02, when a device supports overlapping channel assignment in a channel bandwidth configuration, the middle channel of the group of overlapping channels should be selected for testing.





FCC ID: ZNFVK410		SAR EVALUATION REPORT		Reviewed by: Quality Manager
Document S/N: OY1406021127.ZNF	Test Dates: 06/02/14 - 06/04/14	DUT Type: Portable Tablet		Page 17 of 47

Table 8-4
LTE Band 4 (AWS) Conducted Powers – 15 MHz Bandwidth
Maximum Power

	Frequency [MHz]	Channel	Bandwidth [MHz]	Modulation	RB Size	RB Offset	Conducted Power [dBm]	MPR Allowed per 3GPP [dB]	MPR [dB]
Low	1717.5	20025	15	QPSK	1	0	24.03	0	0
	1717.5	20025	15	QPSK	1	36	24.09	0	0
	1717.5	20025	15	QPSK	1	74	23.92	0	0
	1717.5	20025	15	QPSK	36	0	22.98	0-1	1
	1717.5	20025	15	QPSK	36	18	22.83	0-1	1
	1717.5	20025	15	QPSK	36	37	22.85	0-1	1
	1717.5	20025	15	QPSK	75	0	22.87	0-1	1
	1717.5	20025	15	16QAM	1	0	23.09	0-1	1
	1717.5	20025	15	16QAM	1	36	22.72	0-1	1
	1717.5	20025	15	16QAM	1	74	23.07	0-1	1
	1717.5	20025	15	16QAM	36	0	22.00	0-2	2
	1717.5	20025	15	16QAM	36	18	22.01	0-2	2
1717.5	20025	15	16QAM	36	37	22.08	0-2	2	
1717.5	20025	15	16QAM	75	0	21.85	0-2	2	
Mid	1732.5	20175	15	QPSK	1	0	23.83	0	0
	1732.5	20175	15	QPSK	1	36	23.77	0	0
	1732.5	20175	15	QPSK	1	74	23.72	0	0
	1732.5	20175	15	QPSK	36	0	22.87	0-1	1
	1732.5	20175	15	QPSK	36	18	23.06	0-1	1
	1732.5	20175	15	QPSK	36	37	22.71	0-1	1
	1732.5	20175	15	QPSK	75	0	22.92	0-1	1
	1732.5	20175	15	16QAM	1	0	23.00	0-1	1
	1732.5	20175	15	16QAM	1	36	22.78	0-1	1
	1732.5	20175	15	16QAM	1	74	23.00	0-1	1
	1732.5	20175	15	16QAM	36	0	21.88	0-2	2
	1732.5	20175	15	16QAM	36	18	21.91	0-2	2
1732.5	20175	15	16QAM	36	37	21.72	0-2	2	
1732.5	20175	15	16QAM	75	0	21.84	0-2	2	
High	1747.5	20325	15	QPSK	1	0	23.97	0	0
	1747.5	20325	15	QPSK	1	36	23.76	0	0
	1747.5	20325	15	QPSK	1	74	23.96	0	0
	1747.5	20325	15	QPSK	36	0	22.74	0-1	1
	1747.5	20325	15	QPSK	36	18	22.78	0-1	1
	1747.5	20325	15	QPSK	36	37	23.06	0-1	1
	1747.5	20325	15	QPSK	75	0	22.75	0-1	1
	1747.5	20325	15	16QAM	1	0	23.06	0-1	1
	1747.5	20325	15	16QAM	1	36	22.81	0-1	1
	1747.5	20325	15	16QAM	1	74	22.99	0-1	1
	1747.5	20325	15	16QAM	36	0	21.88	0-2	2
	1747.5	20325	15	16QAM	36	18	22.00	0-2	2
1747.5	20325	15	16QAM	36	37	22.04	0-2	2	
1747.5	20325	15	16QAM	75	0	21.72	0-2	2	

FCC ID: ZNFVK410	 PCTEST <small>ENGINEERING LABORATORY, INC.</small>	SAR EVALUATION REPORT		Reviewed by: Quality Manager
Document S/N: OY1406021127.ZNF	Test Dates: 06/02/14 - 06/04/14	DUT Type: Portable Tablet	Page 18 of 47	

**Table 8-5
LTE Band 4 (AWS) Conducted Powers – 10 MHz Bandwidth
Maximum Power**

	Frequency [MHz]	Channel	Bandwidth [MHz]	Modulation	RB Size	RB Offset	Conducted Power [dBm]	MPR Allowed per 3GPP [dB]	MPR [dB]
Low	1715	20000	10	QPSK	1	0	23.84	0	0
	1715	20000	10	QPSK	1	25	24.04	0	0
	1715	20000	10	QPSK	1	49	23.92	0	0
	1715	20000	10	QPSK	25	0	22.80	0-1	1
	1715	20000	10	QPSK	25	12	23.07	0-1	1
	1715	20000	10	QPSK	25	25	22.77	0-1	1
	1715	20000	10	QPSK	50	0	22.87	0-1	1
	1715	20000	10	16QAM	1	0	23.07	0-1	1
	1715	20000	10	16QAM	1	25	23.05	0-1	1
	1715	20000	10	16QAM	1	49	23.05	0-1	1
	1715	20000	10	16QAM	25	0	21.92	0-2	2
	1715	20000	10	16QAM	25	12	22.07	0-2	2
	1715	20000	10	16QAM	25	25	22.07	0-2	2
	1715	20000	10	16QAM	50	0	22.06	0-2	2
Mid	1732.5	20175	10	QPSK	1	0	23.96	0	0
	1732.5	20175	10	QPSK	1	25	24.00	0	0
	1732.5	20175	10	QPSK	1	49	24.17	0	0
	1732.5	20175	10	QPSK	25	0	23.01	0-1	1
	1732.5	20175	10	QPSK	25	12	23.09	0-1	1
	1732.5	20175	10	QPSK	25	25	23.13	0-1	1
	1732.5	20175	10	QPSK	50	0	23.08	0-1	1
	1732.5	20175	10	16QAM	1	0	22.97	0-1	1
	1732.5	20175	10	16QAM	1	25	23.04	0-1	1
	1732.5	20175	10	16QAM	1	49	23.01	0-1	1
	1732.5	20175	10	16QAM	25	0	21.99	0-2	2
	1732.5	20175	10	16QAM	25	12	22.06	0-2	2
	1732.5	20175	10	16QAM	25	25	22.08	0-2	2
	1732.5	20175	10	16QAM	50	0	22.00	0-2	2
High	1750	20350	10	QPSK	1	0	23.88	0	0
	1750	20350	10	QPSK	1	25	23.79	0	0
	1750	20350	10	QPSK	1	49	24.06	0	0
	1750	20350	10	QPSK	25	0	22.74	0-1	1
	1750	20350	10	QPSK	25	12	23.02	0-1	1
	1750	20350	10	QPSK	25	25	23.07	0-1	1
	1750	20350	10	QPSK	50	0	22.82	0-1	1
	1750	20350	10	16QAM	1	0	23.03	0-1	1
	1750	20350	10	16QAM	1	25	22.73	0-1	1
	1750	20350	10	16QAM	1	49	22.82	0-1	1
	1750	20350	10	16QAM	25	0	22.05	0-2	2
	1750	20350	10	16QAM	25	12	22.02	0-2	2
	1750	20350	10	16QAM	25	25	21.92	0-2	2
	1750	20350	10	16QAM	50	0	21.85	0-2	2



FCC ID: ZNFVK410	 PCTEST ENGINEERING LABORATORY, INC.	SAR EVALUATION REPORT	 LG	Reviewed by: Quality Manager
Document S/N: OY1406021127.ZNF	Test Dates: 06/02/14 - 06/04/14	DUT Type: Portable Tablet		Page 19 of 47

Table 8-6
LTE Band 4 (AWS) Conducted Powers – 5 MHz Bandwidth
Maximum Power

	Frequency [MHz]	Channel	Bandwidth [MHz]	Modulation	RB Size	RB Offset	Conducted Power [dBm]	MPR Allowed per 3GPP [dB]	MPR [dB]
Low	1712.5	19975	5	QPSK	1	0	23.89	0	0
	1712.5	19975	5	QPSK	1	12	23.89	0	0
	1712.5	19975	5	QPSK	1	24	23.91	0	0
	1712.5	19975	5	QPSK	12	0	23.01	0-1	1
	1712.5	19975	5	QPSK	12	6	23.07	0-1	1
	1712.5	19975	5	QPSK	12	13	22.96	0-1	1
	1712.5	19975	5	QPSK	25	0	22.86	0-1	1
	1712.5	19975	5	16-QAM	1	0	22.81	0-1	1
	1712.5	19975	5	16-QAM	1	12	23.04	0-1	1
	1712.5	19975	5	16-QAM	1	24	23.03	0-1	1
	1712.5	19975	5	16-QAM	12	0	21.89	0-2	2
	1712.5	19975	5	16-QAM	12	6	22.02	0-2	2
	1712.5	19975	5	16-QAM	12	13	22.02	0-2	2
1712.5	19975	5	16-QAM	25	0	21.77	0-2	2	
Mid	1732.5	20175	5	QPSK	1	0	23.89	0	0
	1732.5	20175	5	QPSK	1	12	23.88	0	0
	1732.5	20175	5	QPSK	1	24	24.05	0	0
	1732.5	20175	5	QPSK	12	0	22.76	0-1	1
	1732.5	20175	5	QPSK	12	6	22.95	0-1	1
	1732.5	20175	5	QPSK	12	13	22.73	0-1	1
	1732.5	20175	5	QPSK	25	0	23.08	0-1	1
	1732.5	20175	5	16-QAM	1	0	23.08	0-1	1
	1732.5	20175	5	16-QAM	1	12	22.97	0-1	1
	1732.5	20175	5	16-QAM	1	24	22.90	0-1	1
	1732.5	20175	5	16-QAM	12	0	22.01	0-2	2
	1732.5	20175	5	16-QAM	12	6	21.88	0-2	2
	1732.5	20175	5	16-QAM	12	13	22.07	0-2	2
1732.5	20175	5	16-QAM	25	0	21.94	0-2	2	
High	1752.5	20375	5	QPSK	1	0	24.08	0	0
	1752.5	20375	5	QPSK	1	12	23.88	0	0
	1752.5	20375	5	QPSK	1	24	23.74	0	0
	1752.5	20375	5	QPSK	12	0	23.01	0-1	1
	1752.5	20375	5	QPSK	12	6	22.99	0-1	1
	1752.5	20375	5	QPSK	12	13	23.02	0-1	1
	1752.5	20375	5	QPSK	25	0	22.87	0-1	1
	1752.5	20375	5	16-QAM	1	0	22.72	0-1	1
	1752.5	20375	5	16-QAM	1	12	22.96	0-1	1
	1752.5	20375	5	16-QAM	1	24	23.03	0-1	1
	1752.5	20375	5	16-QAM	12	0	21.78	0-2	2
	1752.5	20375	5	16-QAM	12	6	22.02	0-2	2
	1752.5	20375	5	16-QAM	12	13	21.89	0-2	2
1752.5	20375	5	16-QAM	25	0	21.84	0-2	2	



FCC ID: ZNFVK410	 PCTEST ENGINEERING LABORATORY, INC.	SAR EVALUATION REPORT		Reviewed by: Quality Manager
Document S/N: OY1406021127.ZNF	Test Dates: 06/02/14 - 06/04/14	DUT Type: Portable Tablet		Page 20 of 47

Table 8-7
LTE Band 4 (AWS) Conducted Powers – 20 MHz Bandwidth
Reduced Power – Body at 0 mm

	Frequency [MHz]	Channel	Bandwidth [MHz]	Modulation	RB Size	RB Offset	Conducted Power [dBm]	MPR Allowed per 3GPP [dB]	MPR [dB]
Mid	1732.5	20175	20	QPSK	1	0	14.18	0	0
	1732.5	20175	20	QPSK	1	50	14.08	0	0
	1732.5	20175	20	QPSK	1	99	14.01	0	0
	1732.5	20175	20	QPSK	50	0	14.15	0-1	0
	1732.5	20175	20	QPSK	50	25	14.14	0-1	0
	1732.5	20175	20	QPSK	50	50	14.10	0-1	0
	1732.5	20175	20	QPSK	100	0	14.06	0-1	0
	1732.5	20175	20	16QAM	1	0	13.87	0-1	0
	1732.5	20175	20	16QAM	1	50	14.00	0-1	0
	1732.5	20175	20	16QAM	1	99	14.10	0-1	0
	1732.5	20175	20	16QAM	50	0	13.90	0-2	0
	1732.5	20175	20	16QAM	50	25	14.12	0-2	0
	1732.5	20175	20	16QAM	50	50	14.11	0-2	0
	1732.5	20175	20	16QAM	100	0	14.05	0-2	0

Note: LTE Band 4 (AWS) at 10 MHz bandwidth does not support three non-overlapping channels. Per KDB Publication 941225 D05v02, when a device supports overlapping channel assignment in a channel bandwidth configuration, the middle channel of the group of overlapping channels should be selected for testing.



FCC ID: ZNFVK410		SAR EVALUATION REPORT		Reviewed by: Quality Manager
Document S/N: OY1406021127.ZNF	Test Dates: 06/02/14 - 06/04/14	DUT Type: Portable Tablet	Page 21 of 47	

Table 8-8
LTE Band 4 (AWS) Conducted Powers – 15 MHz Bandwidth
Reduced Power – Body at 0 mm

	Frequency [MHz]	Channel	Bandwidth [MHz]	Modulation	RB Size	RB Offset	Conducted Power [dBm]	MPR Allowed per 3GPP [dB]	MPR [dB]
Low	1717.5	20025	15	QPSK	1	0	14.19	0	0
	1717.5	20025	15	QPSK	1	36	13.95	0	0
	1717.5	20025	15	QPSK	1	74	14.02	0	0
	1717.5	20025	15	QPSK	36	0	13.89	0-1	0
	1717.5	20025	15	QPSK	36	18	14.05	0-1	0
	1717.5	20025	15	QPSK	36	37	14.18	0-1	0
	1717.5	20025	15	QPSK	75	0	13.90	0-1	0
	1717.5	20025	15	16QAM	1	0	14.15	0-1	0
	1717.5	20025	15	16QAM	1	36	13.91	0-1	0
	1717.5	20025	15	16QAM	1	74	13.76	0-1	0
	1717.5	20025	15	16QAM	36	0	13.86	0-2	0
	1717.5	20025	15	16QAM	36	18	14.11	0-2	0
1717.5	20025	15	16QAM	36	37	13.88	0-2	0	
1717.5	20025	15	16QAM	75	0	13.89	0-2	0	
Mid	1732.5	20175	15	QPSK	1	0	13.80	0	0
	1732.5	20175	15	QPSK	1	36	13.84	0	0
	1732.5	20175	15	QPSK	1	74	14.10	0	0
	1732.5	20175	15	QPSK	36	0	13.79	0-1	0
	1732.5	20175	15	QPSK	36	18	13.72	0-1	0
	1732.5	20175	15	QPSK	36	37	14.15	0-1	0
	1732.5	20175	15	QPSK	75	0	14.15	0-1	0
	1732.5	20175	15	16QAM	1	0	14.02	0-1	0
	1732.5	20175	15	16QAM	1	36	13.76	0-1	0
	1732.5	20175	15	16QAM	1	74	13.79	0-1	0
	1732.5	20175	15	16QAM	36	0	13.73	0-2	0
	1732.5	20175	15	16QAM	36	18	14.01	0-2	0
1732.5	20175	15	16QAM	36	37	14.10	0-2	0	
1732.5	20175	15	16QAM	75	0	14.04	0-2	0	
High	1747.5	20325	15	QPSK	1	0	13.83	0	0
	1747.5	20325	15	QPSK	1	36	14.00	0	0
	1747.5	20325	15	QPSK	1	74	13.73	0	0
	1747.5	20325	15	QPSK	36	0	13.71	0-1	0
	1747.5	20325	15	QPSK	36	18	14.07	0-1	0
	1747.5	20325	15	QPSK	36	37	13.84	0-1	0
	1747.5	20325	15	QPSK	75	0	14.19	0-1	0
	1747.5	20325	15	16QAM	1	0	13.83	0-1	0
	1747.5	20325	15	16QAM	1	36	13.86	0-1	0
	1747.5	20325	15	16QAM	1	74	13.96	0-1	0
	1747.5	20325	15	16QAM	36	0	13.80	0-2	0
	1747.5	20325	15	16QAM	36	18	14.01	0-2	0
1747.5	20325	15	16QAM	36	37	13.90	0-2	0	
1747.5	20325	15	16QAM	75	0	14.03	0-2	0	



FCC ID: ZNFVK410		SAR EVALUATION REPORT		Reviewed by: Quality Manager
Document S/N: OY1406021127.ZNF	Test Dates: 06/02/14 - 06/04/14	DUT Type: Portable Tablet		Page 22 of 47

Table 8-9
LTE Band 4 (AWS) Conducted Powers – 10 MHz Bandwidth
Reduced Power – Body at 0 mm

	Frequency [MHz]	Channel	Bandwidth [MHz]	Modulation	RB Size	RB Offset	Conducted Power [dBm]	MPR Allowed per 3GPP [dB]	MPR [dB]
Low	1715	20000	10	QPSK	1	0	14.11	0	0
	1715	20000	10	QPSK	1	25	13.89	0	0
	1715	20000	10	QPSK	1	49	13.96	0	0
	1715	20000	10	QPSK	25	0	14.07	0-1	0
	1715	20000	10	QPSK	25	12	14.02	0-1	0
	1715	20000	10	QPSK	25	25	13.94	0-1	0
	1715	20000	10	QPSK	50	0	14.18	0-1	0
	1715	20000	10	16QAM	1	0	14.05	0-1	0
	1715	20000	10	16QAM	1	25	14.11	0-1	0
	1715	20000	10	16QAM	1	49	13.88	0-1	0
	1715	20000	10	16QAM	25	0	14.00	0-2	0
	1715	20000	10	16QAM	25	12	14.16	0-2	0
	1715	20000	10	16QAM	25	25	13.90	0-2	0
1715	20000	10	16QAM	50	0	14.03	0-2	0	
Mid	1732.5	20175	10	QPSK	1	0	13.91	0	0
	1732.5	20175	10	QPSK	1	25	14.18	0	0
	1732.5	20175	10	QPSK	1	49	13.75	0	0
	1732.5	20175	10	QPSK	25	0	13.96	0-1	0
	1732.5	20175	10	QPSK	25	12	14.19	0-1	0
	1732.5	20175	10	QPSK	25	25	13.88	0-1	0
	1732.5	20175	10	QPSK	50	0	14.19	0-1	0
	1732.5	20175	10	16QAM	1	0	14.00	0-1	0
	1732.5	20175	10	16QAM	1	25	13.87	0-1	0
	1732.5	20175	10	16QAM	1	49	14.15	0-1	0
	1732.5	20175	10	16QAM	25	0	13.97	0-2	0
	1732.5	20175	10	16QAM	25	12	14.11	0-2	0
	1732.5	20175	10	16QAM	25	25	13.99	0-2	0
1732.5	20175	10	16QAM	50	0	14.12	0-2	0	
High	1750	20350	10	QPSK	1	0	14.00	0	0
	1750	20350	10	QPSK	1	25	14.02	0	0
	1750	20350	10	QPSK	1	49	14.01	0	0
	1750	20350	10	QPSK	25	0	13.98	0-1	0
	1750	20350	10	QPSK	25	12	13.98	0-1	0
	1750	20350	10	QPSK	25	25	13.89	0-1	0
	1750	20350	10	QPSK	50	0	14.10	0-1	0
	1750	20350	10	16QAM	1	0	14.04	0-1	0
	1750	20350	10	16QAM	1	25	13.92	0-1	0
	1750	20350	10	16QAM	1	49	14.17	0-1	0
	1750	20350	10	16QAM	25	0	14.04	0-2	0
	1750	20350	10	16QAM	25	12	13.93	0-2	0
	1750	20350	10	16QAM	25	25	13.96	0-2	0
1750	20350	10	16QAM	50	0	13.86	0-2	0	





FCC ID: ZNFVK410		SAR EVALUATION REPORT		Reviewed by: Quality Manager
Document S/N: OY1406021127.ZNF	Test Dates: 06/02/14 - 06/04/14	DUT Type: Portable Tablet	Page 23 of 47	

Table 8-10
LTE Band 4 (AWS) Conducted Powers – 5 MHz Bandwidth
Reduced Power – Body at 0 mm

	Frequency [MHz]	Channel	Bandwidth [MHz]	Modulation	RB Size	RB Offset	Conducted Power [dBm]	MPR Allowed per 3GPP [dB]	MPR [dB]
Low	1712.5	19975	5	QPSK	1	0	14.10	0	0
	1712.5	19975	5	QPSK	1	12	13.74	0	0
	1712.5	19975	5	QPSK	1	24	14.01	0	0
	1712.5	19975	5	QPSK	12	0	13.86	0-1	0
	1712.5	19975	5	QPSK	12	6	14.04	0-1	0
	1712.5	19975	5	QPSK	12	13	13.80	0-1	0
	1712.5	19975	5	QPSK	25	0	13.79	0-1	0
	1712.5	19975	5	16-QAM	1	0	14.19	0-1	0
	1712.5	19975	5	16-QAM	1	12	13.72	0-1	0
	1712.5	19975	5	16-QAM	1	24	14.06	0-1	0
	1712.5	19975	5	16-QAM	12	0	14.03	0-2	0
	1712.5	19975	5	16-QAM	12	6	14.18	0-2	0
1712.5	19975	5	16-QAM	12	13	13.83	0-2	0	
1712.5	19975	5	16-QAM	25	0	13.99	0-2	0	
Mid	1732.5	20175	5	QPSK	1	0	13.87	0	0
	1732.5	20175	5	QPSK	1	12	13.95	0	0
	1732.5	20175	5	QPSK	1	24	14.02	0	0
	1732.5	20175	5	QPSK	12	0	13.93	0-1	0
	1732.5	20175	5	QPSK	12	6	14.01	0-1	0
	1732.5	20175	5	QPSK	12	13	13.91	0-1	0
	1732.5	20175	5	QPSK	25	0	14.06	0-1	0
	1732.5	20175	5	16-QAM	1	0	14.04	0-1	0
	1732.5	20175	5	16-QAM	1	12	14.01	0-1	0
	1732.5	20175	5	16-QAM	1	24	14.05	0-1	0
	1732.5	20175	5	16-QAM	12	0	13.74	0-2	0
	1732.5	20175	5	16-QAM	12	6	13.71	0-2	0
1732.5	20175	5	16-QAM	12	13	14.03	0-2	0	
1732.5	20175	5	16-QAM	25	0	14.04	0-2	0	
High	1752.5	20375	5	QPSK	1	0	14.16	0	0
	1752.5	20375	5	QPSK	1	12	14.13	0	0
	1752.5	20375	5	QPSK	1	24	13.86	0	0
	1752.5	20375	5	QPSK	12	0	14.11	0-1	0
	1752.5	20375	5	QPSK	12	6	13.93	0-1	0
	1752.5	20375	5	QPSK	12	13	13.95	0-1	0
	1752.5	20375	5	QPSK	25	0	13.85	0-1	0
	1752.5	20375	5	16-QAM	1	0	13.83	0-1	0
	1752.5	20375	5	16-QAM	1	12	14.07	0-1	0
	1752.5	20375	5	16-QAM	1	24	13.71	0-1	0
	1752.5	20375	5	16-QAM	12	0	13.82	0-2	0
	1752.5	20375	5	16-QAM	12	6	14.00	0-2	0
1752.5	20375	5	16-QAM	12	13	13.84	0-2	0	
1752.5	20375	5	16-QAM	25	0	14.16	0-2	0	

FCC ID: ZNFVK410	 PCTEST ENGINEERING LABORATORY, INC.	SAR EVALUATION REPORT		Reviewed by: Quality Manager
Document S/N: OY1406021127.ZNF	Test Dates: 06/02/14 - 06/04/14	DUT Type: Portable Tablet		Page 24 of 47

8.2 WLAN Conducted Powers

Table 8-11
IEEE 802.11b Average RF Power

Mode	Freq [MHz]	Channel	802.11b Conducted Power [dBm]			
			Data Rate [Mbps]			
			1	2	5.5	11
802.11b	2412	1*	11.27	11.27	11.25	11.25
802.11b	2437	6*	11.22	11.24	11.29	11.27
802.11b	2462	11*	11.99	11.97	11.99	11.98

Table 8-12
IEEE 802.11g Average RF Power

Mode	Freq [MHz]	Channel	802.11g Conducted Power [dBm]							
			Data Rate [Mbps]							
			6	9	12	18	24	36	48	54
802.11g	2412	1	7.86	7.94	7.98	7.91	7.96	7.99	7.98	7.90
802.11g	2437	6	7.90	7.87	7.94	8.04	7.89	7.92	7.95	7.88
802.11g	2462	11	7.77	7.85	7.78	7.86	7.79	7.85	7.81	7.78

Table 8-13
IEEE 802.11n Average RF Power

Mode	Freq [MHz]	Channel	802.11n (2.4GHz) Conducted Power [dBm]							
			Data Rate [Mbps]							
			6.5	13	19.5	26	39	52	58.5	65
802.11n	2412	1	6.90	6.86	6.77	6.90	6.95	6.94	6.98	6.95
802.11n	2437	6	6.90	6.91	6.85	6.91	6.93	6.95	6.95	7.06
802.11n	2462	11	6.87	6.71	6.84	6.83	6.88	6.80	6.99	6.84



FCC ID: ZNFVK410	 PCTEST ENGINEERING LABORATORY, INC.	SAR EVALUATION REPORT	 LG	Reviewed by: Quality Manager
Document S/N: OY1406021127.ZNF	Test Dates: 06/02/14 - 06/04/14	DUT Type: Portable Tablet		Page 25 of 47

Table 8-14
IEEE 802.11a Average RF Power

Mode	Freq [MHz]	Channel	802.11a Conducted Power [dBm]							
			Data Rate [Mbps]							
			6	9	12	18	24	36	48	54
802.11a	5180	36*	9.27	9.39	9.43	9.31	9.35	9.39	9.43	9.30
802.11a	5200	40	9.51	9.68	9.66	9.47	9.58	9.65	9.68	9.54
802.11a	5220	44	9.42	9.52	9.66	9.48	9.49	9.54	9.61	9.45
802.11a	5240	48*	9.46	9.62	9.57	9.57	9.61	9.54	9.59	9.42
802.11a	5260	52*	9.43	9.36	9.41	9.55	9.28	9.31	9.38	9.35
802.11a	5280	56	9.21	9.08	9.27	9.34	9.09	9.09	9.18	9.16
802.11a	5300	60	9.84	9.74	9.84	9.96	9.77	9.73	9.76	9.83
802.11a	5320	64*	10.15	10.12	10.04	10.30	10.03	10.05	10.05	10.11
802.11a	5500	100	10.01	9.99	9.96	10.11	9.97	9.97	9.98	10.02
802.11a	5520	104*	10.07	10.02	10.06	10.15	9.99	9.99	10.04	10.07
802.11a	5540	108	10.05	10.10	9.99	10.16	10.00	9.99	10.06	10.06
802.11a	5560	112	10.15	10.18	10.12	10.22	10.06	10.16	10.13	10.13
802.11a	5580	116*	10.11	10.15	10.13	10.17	10.14	10.08	10.14	10.10
802.11a	5600	120	N/A	N/A	N/A	N/A	N/A	N/A	N/A	N/A
802.11a	5620	124	N/A	N/A	N/A	N/A	N/A	N/A	N/A	N/A
802.11a	5640	128	N/A	N/A	N/A	N/A	N/A	N/A	N/A	N/A
802.11a	5660	132	10.12	10.17	10.08	10.19	10.06	10.14	10.04	10.18
802.11a	5680	136*	9.93	9.92	9.97	10.12	9.91	9.90	9.88	9.91
802.11a	5700	140	9.97	9.89	9.91	10.07	9.89	9.93	9.98	10.00
802.11a	5745	149*	10.24	10.21	10.36	10.31	10.35	10.29	9.92	10.10
802.11a	5765	153	10.43	10.40	10.38	10.32	10.33	10.30	10.14	10.07
802.11a	5785	157*	10.44	10.34	10.33	10.41	10.28	10.26	10.38	10.32
802.11a	5805	161	10.09	10.07	10.11	10.23	10.05	10.19	10.11	10.17
802.11a	5825	165*	10.11	10.08	10.09	10.15	10.23	10.17	10.04	10.02

Per FCC KDB Publication 443999 and RSS-210 A9.2(3), transmission on channels which overlap the 5600-5650 MHz is prohibited as a client. This device does not transmit any beacons or initiate any transmissions in 5.3 and 5.5 GHz Band.

(*) – indicates default channels per KDB Publication 248227 D01v01r02. When the adjacent channels are higher in power than the default channels, these “required channels” are considered for SAR testing instead of the default channels.



FCC ID: ZNFVK410		SAR EVALUATION REPORT		Reviewed by: Quality Manager
Document S/N: OY1406021127.ZNF	Test Dates: 06/02/14 - 06/04/14	DUT Type: Portable Tablet		Page 26 of 47

Table 8-15
IEEE 802.11n Average RF Power – 20 MHz Bandwidth

Mode	Freq [MHz]	Channel	20MHz BW 802.11n (5GHz) Conducted Power [dBm]							
			Data Rate [Mbps]							
			6.5	13	19.5	26	39	52	58.5	65
802.11n	5180	36	8.72	8.75	8.85	8.60	8.59	8.35	8.44	8.45
802.11n	5200	40	8.61	8.82	8.98	8.57	8.64	8.35	8.49	8.52
802.11n	5220	44	8.77	8.52	8.64	8.38	8.39	8.18	8.20	8.25
802.11n	5240	48	8.50	8.61	8.59	8.43	8.40	8.50	8.46	8.44
802.11n	5260	52	8.61	8.61	8.59	8.43	8.40	8.50	8.46	8.44
802.11n	5280	56	8.52	9.26	9.16	9.04	9.00	9.11	9.07	9.06
802.11n	5300	60	9.23	9.22	9.24	8.99	8.96	9.17	9.07	9.04
802.11n	5320	64	9.22	9.21	8.98	8.95	8.97	9.01	8.95	9.02
802.11n	5500	100	8.96	9.21	8.98	8.95	8.97	9.01	8.95	9.02
802.11n	5520	104	9.11	9.31	9.10	9.11	9.12	9.14	9.11	9.08
802.11n	5540	108	9.09	9.46	9.14	9.07	9.09	9.12	9.07	9.09
802.11n	5560	112	9.12	9.34	9.07	9.19	9.11	9.15	9.12	9.20
802.11n	5580	116	9.13	9.22	9.08	9.15	9.23	9.17	9.15	9.16
802.11n	5600	120	N/A	N/A	N/A	N/A	N/A	N/A	N/A	N/A
802.11n	5620	124	N/A	N/A	N/A	N/A	N/A	N/A	N/A	N/A
802.11n	5640	128	N/A	N/A	N/A	N/A	N/A	N/A	N/A	N/A
802.11n	5660	132	9.16	9.30	9.00	9.08	9.08	9.10	9.04	9.16
802.11n	5680	136	9.05	9.28	9.02	9.00	9.03	9.03	9.04	9.12
802.11n	5700	140	9.01	9.38	9.34	9.32	9.39	9.40	9.29	9.34
802.11n	5745	149	9.51	9.38	9.34	9.32	9.39	9.40	9.29	9.34
802.11n	5765	153	9.45	9.21	9.26	9.29	9.36	9.31	9.29	9.18
802.11n	5785	157	9.42	9.08	9.04	8.99	9.15	9.01	8.97	9.01
802.11n	5805	161	9.18	8.94	8.83	8.90	8.84	8.94	8.83	8.88
802.11n	5825	165	9.03	9.02	8.89	8.94	8.96	9.06	8.85	8.84

Per FCC KDB Publication 443999 and RSS-210 A9.2(3), transmission on channels which overlap the 5600-5650 MHz is prohibited as a client. This device does not transmit any beacons or initiate any transmissions in 5.3 and 5.5 GHz Band.



FCC ID: ZNFVK410	 PCTEST ENGINEERING LABORATORY, INC.	SAR EVALUATION REPORT	 LG	Reviewed by: Quality Manager
Document S/N: OY1406021127.ZNF	Test Dates: 06/02/14 - 06/04/14	DUT Type: Portable Tablet		Page 27 of 47

Table 8-16
IEEE 802.11n Average RF Power – 40 MHz Bandwidth

Mode	Freq [MHz]	Channel	40MHz BW 802.11n (5GHz) Conducted Power [dBm]							
			Data Rate [Mbps]							
			13.5	27	40.5	54	81	108	121.5	135
802.11n	5190	38	9.32	9.14	9.33	9.16	9.09	9.18	9.10	9.15
802.11n	5230	46	9.03	9.13	9.25	9.21	9.16	9.29	9.17	9.05
802.11n	5270	54	9.19	8.96	9.06	9.01	9.05	9.07	9.02	8.95
802.11n	5310	62	9.35	9.81	9.88	9.53	9.52	9.54	9.71	9.61
802.11n	5510	102	9.39	9.60	9.65	9.38	9.35	9.32	9.46	9.37
802.11n	5550	110	9.61	9.59	9.55	9.52	9.50	9.40	9.44	9.45
802.11n	5590	118	N/A	N/A	N/A	N/A	N/A	N/A	N/A	N/A
802.11n	5630	126	N/A	N/A	N/A	N/A	N/A	N/A	N/A	N/A
802.11n	5670	134	9.68	9.65	9.66	9.51	9.55	9.44	9.57	9.42
802.11n	5755	151	9.98	9.95	9.22	9.26	9.44	9.46	9.40	9.29
802.11n	5795	159	9.35	9.40	9.42	9.35	9.34	9.29	9.34	9.28

Per FCC KDB Publication 443999 and RSS-210 A9.2(3), transmission on channels which overlap the 5600-5650 MHz is prohibited as a client. This device does not transmit any beacons or initiate any transmissions in 5.3 and 5.5 GHz Band.

Justification for reduced test configurations for WIFI channels per KDB Publication 248227 D01v01r02 and October 2012/April 2013 FCC/TCB Meeting Notes:

- For 2.4 GHz, highest average RF output power channel for the lowest data rate for IEEE 802.11b were selected for SAR evaluation. Other IEEE 802.11 modes (including 802.11g/n) were not investigated since the average output powers over all channels and data rates were not more than 0.25 dB higher than the tested channel in the lowest data rate of IEEE 802.11b mode.
- For 5 GHz, highest average RF output power channel for the lowest data rate for IEEE 802.11a were selected for SAR evaluation. Other IEEE 802.11 modes (including 802.11n 20 MHz and 40 MHz) were not investigated since the average output powers over all channels and data rates were not more than 0.25 dB higher than the tested channel in the lowest data rate of IEEE 802.11a mode.
- When the maximum extrapolated peak SAR of the zoom scan for the maximum output channel is <1.6 W/kg and the reported 1g averaged SAR is <0.8 W/kg, SAR testing on other channels is not required. Otherwise, the other default (or corresponding required) test channels were additionally tested using the lowest data rate.
- The bolded data rate and channel above were tested for SAR.

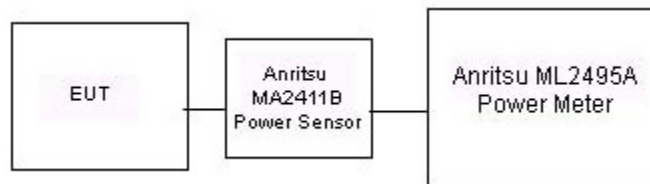



Figure 8-1
Power Measurement Setup

FCC ID: ZNFVK410		SAR EVALUATION REPORT		Reviewed by: Quality Manager
Document S/N: OY1406021127.ZNF	Test Dates: 06/02/14 - 06/04/14	DUT Type: Portable Tablet	Page 28 of 47	



9 SYSTEM VERIFICATION

9.1 Tissue Verification

**Table 9-1
Measured Tissue Properties**

Calibrated for Tests Performed on:	Tissue Type	Tissue Temp During Calibration (C°)	Measured Frequency (MHz)	Measured Conductivity, σ (S/m)	Measured Dielectric Constant, ϵ	TARGET Conductivity, σ (S/m)	TARGET Dielectric Constant, ϵ	% dev σ	% dev ϵ
06/02/2014	750B	23.0	740	0.968	55.615	0.963	55.570	0.52%	0.08%
			755	0.981	55.465	0.964	55.512	1.76%	-0.08%
			770	0.995	55.314	0.965	55.453	3.11%	-0.25%
			785	1.010	55.179	0.966	55.395	4.55%	-0.39%
06/04/2014	1750B	22.8	1710	1.414	53.024	1.463	53.537	-3.35%	-0.96%
			1750	1.457	52.864	1.488	53.432	-2.08%	-1.06%
			1790	1.497	52.719	1.514	53.326	-1.12%	-1.14%
06/02/2014	2450B	22.4	2401	1.883	51.238	1.903	52.765	-1.05%	-2.89%
			2450	1.952	51.042	1.950	52.700	0.10%	-3.15%
			2499	2.017	50.848	2.019	52.638	-0.10%	-3.40%
06/02/2014	5200B-5800B	24.5	5200	5.243	47.101	5.299	49.014	-1.06%	-3.90%
			5240	5.300	47.083	5.346	48.960	-0.86%	-3.83%
			5260	5.324	47.042	5.369	48.933	-0.84%	-3.86%
			5300	5.376	47.023	5.416	48.879	-0.74%	-3.80%
			5320	5.408	46.986	5.439	48.851	-0.57%	-3.82%
			5500	5.644	46.819	5.650	48.607	-0.11%	-3.68%
			5520	5.668	46.783	5.673	48.580	-0.09%	-3.70%
			5560	5.726	46.722	5.720	48.526	0.10%	-3.72%
			5600	5.772	46.705	5.766	48.471	0.10%	-3.64%
			5660	5.848	46.569	5.837	48.390	0.19%	-3.76%
			5765	5.976	46.393	5.959	48.248	0.29%	-3.84%
			5785	5.998	46.375	5.982	48.220	0.27%	-3.83%
			5800	6.004	46.303	6.000	48.200	0.07%	-3.94%
5825	6.038	46.295	6.029	48.166	0.15%	-3.88%			

The above measured tissue parameters were used in the DASY software. The DASY software was used to perform interpolation to determine the dielectric parameters at the SAR test device frequencies (per KDB Publication 865664 and IEEE 1528-2013 6.6.1.2). The tissue parameters listed in the SAR test plots may slightly differ from the table above due to significant digit rounding in the software.

FCC ID: ZNFVK410	 PCTEST ENGINEERING LABORATORY, INC.	SAR EVALUATION REPORT	 LG	Reviewed by: Quality Manager
Document S/N: OY1406021127.ZNF	Test Dates: 06/02/14 - 06/04/14	DUT Type: Portable Tablet		Page 29 of 47

9.2 Test System Verification

Prior to SAR assessment, the system is verified to $\pm 10\%$ of the SAR measurement on the reference dipole at the time of calibration by the calibration facility. Full system validation status and result summary can be found in Appendix E.

Table 9-2
System Verification Results

System Verification TARGET & MEASURED												
SAR System #	Tissue Frequency (MHz)	Tissue Type	Date:	Amb. Temp (°C)	Liquid Temp (°C)	Input Power (W)	Dipole SN	Probe SN	Measured SAR _{1g} (W/kg)	1 W Target SAR _{1g} (W/kg)	1 W Normalized SAR _{1g} (W/kg)	Deviation _{1g} (%)
J	750	BODY	06/02/2014	23.3	23.0	0.100	1003	3332	0.903	8.770	9.030	2.96%
K	1750	BODY	06/04/2014	24.0	22.8	0.100	1051	3333	3.840	37.400	38.400	2.67%
G	2450	BODY	06/02/2014	24.5	23.0	0.100	719	3258	5.050	51.700	50.500	-2.32%
A	5200	BODY	06/02/2014	24.3	24.5	0.100	1007	3920	7.280	72.600	72.800	0.28%
A	5300	BODY	06/02/2014	24.4	24.5	0.100	1007	3920	7.540	74.700	75.400	0.94%
A	5500	BODY	06/02/2014	24.5	24.5	0.100	1007	3920	7.010	75.900	70.100	-7.64%
A	5600	BODY	06/02/2014	24.5	24.5	0.100	1007	3920	7.540	77.300	75.400	-2.46%
A	5800	BODY	06/02/2014	24.5	24.5	0.100	1007	3920	6.900	72.900	69.000	-5.35%

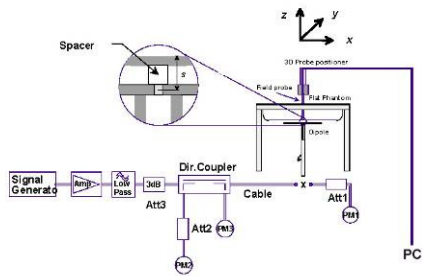



Figure 9-1
System Verification Setup Diagram



Figure 9-2
System Verification Setup Photo

FCC ID: ZNFVK410		SAR EVALUATION REPORT		Reviewed by: Quality Manager
Document S/N: OY1406021127.ZNF	Test Dates: 06/02/14 - 06/04/14	DUT Type: Portable Tablet		Page 30 of 47

10 SAR DATA SUMMARY



10.1 Standalone Body SAR Data

**Table 10-1
LTE Band 13 Body SAR Data**

MEASUREMENT RESULTS																			
FREQUENCY		Mode	Bandwidth [MHz]	Maximum Allowed Power [dBm]	Conducted Power [dBm]	Power Drift [dB]	MPR [dB]	Device Serial Number	Modulation	RB Size	RB Offset	Spacing	Side	Duty Cycle	SAR (1g) (W/kg)	Scaling Factor	Scaled SAR (1g) (W/kg)	Plot #	
MHz	Ch.																		
782.00	23230	Mid	LTE Band 13	10	24.2	24.19	0.04	0	0206-4	QPSK	1	0	14 mm	back	1:1	0.316	1.002	0.317	
782.00	23230	Mid	LTE Band 13	10	23.2	23.13	0.00	1	0206-4	QPSK	25	12	14 mm	back	1:1	0.232	1.016	0.236	
782.00	23230	Mid	LTE Band 13	10	24.2	24.19	0.03	0	0206-4	QPSK	1	0	16 mm	top	1:1	0.106	1.002	0.106	
782.00	23230	Mid	LTE Band 13	10	23.2	23.13	0.08	1	0206-4	QPSK	25	12	16 mm	top	1:1	0.035	1.016	0.036	
782.00	23230	Mid	LTE Band 13	10	24.2	24.19	0.14	0	0206-4	QPSK	1	0	7 mm	right	1:1	0.240	1.002	0.240	
782.00	23230	Mid	LTE Band 13	10	23.2	23.13	0.07	1	0206-4	QPSK	25	12	7 mm	right	1:1	0.187	1.016	0.190	
782.00	23230	Mid	LTE Band 13	10	24.2	24.19	0.08	0	0206-4	QPSK	1	0	0 mm	left	1:1	0.710	1.002	0.711	A1
782.00	23230	Mid	LTE Band 13	10	23.2	23.13	0.08	1	0206-4	QPSK	25	12	0 mm	left	1:1	0.455	1.016	0.462	
782.00	23230	Mid	LTE Band 13	10	20.2	20.17	-0.01	0	0206-5	QPSK	1	49	0 mm	back	1:1	0.565	1.007	0.569	
782.00	23230	Mid	LTE Band 13	10	20.2	20.14	-0.06	0	0206-5	QPSK	25	12	0 mm	back	1:1	0.605	1.014	0.613	
782.00	23230	Mid	LTE Band 13	10	20.2	20.17	-0.07	0	0206-5	QPSK	1	49	0 mm	top	1:1	0.216	1.007	0.218	
782.00	23230	Mid	LTE Band 13	10	20.2	20.14	-0.05	0	0206-5	QPSK	25	12	0 mm	top	1:1	0.241	1.014	0.244	
782.00	23230	Mid	LTE Band 13	10	20.2	20.17	0.02	0	0206-5	QPSK	1	49	0 mm	right	1:1	0.359	1.007	0.362	
782.00	23230	Mid	LTE Band 13	10	20.2	20.14	0.05	0	0206-5	QPSK	25	12	0 mm	right	1:1	0.296	1.014	0.300	
ANSI / IEEE C95.1 1992 - SAFETY LIMIT Spatial Peak Uncontrolled Exposure/General Population								Body 1.6 W/kg (mW/g) averaged over 1 gram											

**Table 10-2
LTE Band 4 (AWS) Body SAR Data**

MEASUREMENT RESULTS																			
FREQUENCY		Mode	Bandwidth [MHz]	Maximum Allowed Power [dBm]	Conducted Power [dBm]	Power Drift [dB]	MPR [dB]	Device Serial Number	Modulation	RB Size	RB Offset	Spacing	Side	Duty Cycle	SAR (1g) (W/kg)	Scaling Factor	Scaled SAR (1g) (W/kg)	Plot #	
MHz	Ch.																		
1732.50	20175	Mid	LTE Band 4 (AWS)	20	24.2	24.15	-0.03	0	0206-4	QPSK	1	0	14 mm	back	1:1	0.463	1.012	0.469	
1732.50	20175	Mid	LTE Band 4 (AWS)	20	23.2	23.08	-0.06	1	0206-4	QPSK	50	50	14 mm	back	1:1	0.328	1.028	0.337	
1732.50	20175	Mid	LTE Band 4 (AWS)	20	24.2	24.15	-0.01	0	0206-4	QPSK	1	0	16 mm	top	1:1	0.340	1.012	0.344	
1732.50	20175	Mid	LTE Band 4 (AWS)	20	23.2	23.08	0.00	1	0206-4	QPSK	50	50	16 mm	top	1:1	0.282	1.028	0.290	
1732.50	20175	Mid	LTE Band 4 (AWS)	20	24.2	24.15	0.04	0	0206-4	QPSK	1	0	7 mm	right	1:1	0.761	1.012	0.770	A2
1732.50	20175	Mid	LTE Band 4 (AWS)	20	23.2	23.08	0.09	1	0206-4	QPSK	50	50	7 mm	right	1:1	0.593	1.028	0.610	
1732.50	20175	Mid	LTE Band 4 (AWS)	20	24.2	24.15	0.08	0	0206-4	QPSK	1	0	0 mm	left	1:1	0.467	1.012	0.473	
1732.50	20175	Mid	LTE Band 4 (AWS)	20	23.2	23.08	0.06	1	0206-4	QPSK	50	50	0 mm	left	1:1	0.388	1.028	0.399	
1732.50	20175	Mid	LTE Band 4 (AWS)	20	14.2	14.18	0.03	0	0206-5	QPSK	1	0	0 mm	back	1:1	0.584	1.005	0.587	
1732.50	20175	Mid	LTE Band 4 (AWS)	20	14.2	14.15	0.04	0	0206-5	QPSK	50	0	0 mm	back	1:1	0.588	1.012	0.595	
1732.50	20175	Mid	LTE Band 4 (AWS)	20	14.2	14.18	-0.03	0	0206-5	QPSK	1	0	0 mm	top	1:1	0.171	1.005	0.172	
1732.50	20175	Mid	LTE Band 4 (AWS)	20	14.2	14.15	0.01	0	0206-5	QPSK	50	0	0 mm	top	1:1	0.171	1.012	0.173	
1732.50	20175	Mid	LTE Band 4 (AWS)	20	14.2	14.18	0.03	0	0206-5	QPSK	1	0	0 mm	right	1:1	0.182	1.005	0.183	
1732.50	20175	Mid	LTE Band 4 (AWS)	20	14.2	14.15	0.03	0	0206-5	QPSK	50	0	0 mm	right	1:1	0.185	1.012	0.187	
ANSI / IEEE C95.1 1992 - SAFETY LIMIT Spatial Peak Uncontrolled Exposure/General Population								Body 1.6 W/kg (mW/g) averaged over 1 gram											



FCC ID: ZNFVK410		SAR EVALUATION REPORT		Reviewed by: Quality Manager
Document S/N: OY1406021127.ZNF	Test Dates: 06/02/14 - 06/04/14	DUT Type: Portable Tablet	Page 31 of 47	

**Table 10-3
DTS Body SAR Data**

MEASUREMENT RESULTS															
FREQUENCY		Mode	Service	Maximum Allowed Power [dBm]	Conducted Power [dBm]	Power Drift [dB]	Spacing	Device Serial Number	Data Rate (Mbps)	Side	Duty Cycle	SAR (1g)	Scaling Factor	Scaled SAR (1g)	Plot #
MHz	Ch.											(W/kg)		(W/kg)	
2462	11	IEEE 802.11b	DSSS	12.5	11.99	0.20	0 mm	0206-11	1	back	1:1	0.383	1.125	0.431	A3
2462	11	IEEE 802.11b	DSSS	12.5	11.99	0.04	0 mm	0206-11	1	top	1:1	0.168	1.125	0.189	
2462	11	IEEE 802.11b	DSSS	12.5	11.99	0.03	0 mm	0206-11	1	left	1:1	0.244	1.125	0.275	
5785	157	IEEE 802.11a	OFDM	11.0	10.44	0.15	0 mm	0206-11	6	back	1:1	0.183	1.138	0.208	A4
5785	157	IEEE 802.11a	OFDM	11.0	10.44	0.17	0 mm	0206-11	6	top	1:1	0.024	1.138	0.027	
5785	157	IEEE 802.11a	OFDM	11.0	10.44	-0.15	0 mm	0206-11	6	left	1:1	0.146	1.138	0.166	
ANSI / IEEE C95.1 1992 - SAFETY LIMIT Spatial Peak Uncontrolled Exposure/General Population							Body 1.6 W/kg (mW/g) averaged over 1 gram								

**Table 10-4
NII Body SAR Data**

MEASUREMENT RESULTS															
FREQUENCY		Mode	Service	Maximum Allowed Power [dBm]	Conducted Power [dBm]	Power Drift [dB]	Spacing	Device Serial Number	Data Rate (Mbps)	Side	Duty Cycle	SAR (1g)	Scaling Factor	Scaled SAR (1g)	Plot #
MHz	Ch.											(W/kg)		(W/kg)	
5200	40	IEEE 802.11a	OFDM	11.0	9.51	0.04	0 mm	0206-11	6	back	1:1	0.363	1.409	0.511	
5240	48	IEEE 802.11a	OFDM	11.0	9.46	0.03	0 mm	0206-11	6	back	1:1	0.438	1.426	0.625	
5200	40	IEEE 802.11a	OFDM	11.0	9.51	0.19	0 mm	0206-11	6	top	1:1	0.173	1.409	0.244	
5200	40	IEEE 802.11a	OFDM	11.0	9.51	-0.13	0 mm	0206-11	6	left	1:1	0.145	1.409	0.204	
5260	52	IEEE 802.11a	OFDM	11.0	9.43	0.04	0 mm	0206-11	6	back	1:1	0.454	1.435	0.651	A5
5320	64	IEEE 802.11a	OFDM	11.0	10.15	0.06	0 mm	0206-11	6	back	1:1	0.431	1.216	0.524	
5320	64	IEEE 802.11a	OFDM	11.0	10.15	-0.01	0 mm	0206-11	6	top	1:1	0.187	1.216	0.227	
5260	52	IEEE 802.11a	OFDM	11.0	9.43	-0.14	0 mm	0206-11	6	left	1:1	0.204	1.435	0.293	
5320	64	IEEE 802.11a	OFDM	11.0	10.15	-0.12	0 mm	0206-11	6	left	1:1	0.240	1.216	0.292	
5520	104	IEEE 802.11a	OFDM	11.0	10.07	0.06	0 mm	0206-11	6	back	1:1	0.338	1.239	0.419	
5560	112	IEEE 802.11a	OFDM	11.0	10.15	0.03	0 mm	0206-11	6	back	1:1	0.333	1.216	0.405	
5660	132	IEEE 802.11a	OFDM	11.0	10.12	0.15	0 mm	0206-11	6	back	1:1	0.261	1.225	0.320	
5560	112	IEEE 802.11a	OFDM	11.0	10.15	0.06	0 mm	0206-11	6	top	1:1	0.082	1.216	0.100	
5560	112	IEEE 802.11a	OFDM	11.0	10.15	-0.15	0 mm	0206-11	6	left	1:1	0.259	1.216	0.315	
ANSI / IEEE C95.1 1992 - SAFETY LIMIT Spatial Peak Uncontrolled Exposure/General Population							Body 1.6 W/kg (mW/g) averaged over 1 gram								

FCC ID: ZNFVK410		SAR EVALUATION REPORT		Reviewed by: Quality Manager
Document S/N: OY1406021127.ZNF	Test Dates: 06/02/14 - 06/04/14	DUT Type: Portable Tablet		Page 32 of 47

10.2 SAR Test Notes

General Notes:



1. The test data reported are the worst-case SAR values according to test procedures specified in FCC KDB 616217, and FCC KDB Publication 447498 D01v05.
2. Batteries are fully charged at the beginning of the SAR measurements.
3. Liquid tissue depth was at least 15.0 cm for all frequencies.
4. The manufacturer has confirmed that the device(s) tested have the same physical, mechanical and thermal characteristics and are within operational tolerances expected for production units.
5. SAR results were scaled to the maximum allowed power to demonstrate compliance per FCC KDB Publication 447498 D01v05.
6. Per FCC KDB 865664 D01 v01, variability SAR tests were not performed since the measured SAR results for a frequency band were not greater than 0.8 W/kg. Please see Section 12 for variability analysis.
7. Per FCC KDB 616217 D04 Section 4.3, SAR tests are required for the back surface and edges of the tablet with the tablet touching the phantom. The SAR Exclusion Threshold in FCC KDB 447498 D01v05 was applied to determine SAR test exclusion for adjacent edge configurations. SAR tests were required for top, right, and left edge for the main antenna and top and left edge for the BT/WLAN antenna.

LTE Notes:

1. LTE Considerations: LTE test configurations are determined according to SAR Evaluation Considerations for LTE Devices in FCC KDB Publication 941225 D05v02r01. The general test procedures used for testing can be found in Section 7.3.4.
2. MPR is permanently implemented for this device by the manufacturer. The specific manufacturer target MPR is indicated alongside the SAR results. MPR is enabled for this device, according to 3GPP TS36.101 Section 6.2.3 – 6.2.5 under Table 6.2.3-1.
3. A-MPR was disabled for all SAR tests by setting NS=01 on the base station simulator. SAR tests were performed with the same number of RB and RB offsets transmitting on all TTI frames (maximum TTI).

WLAN Notes:

1. There is no proximity sensor power reduction mechanism applied for WLAN or Bluetooth.
2. Justification for reduced test configurations for WIFI channels per KDB Publication 248227 D01v01r02 and October 2012 FCC/TCB Meeting Notes for 2.4 GHz WIFI: Highest average RF output power channel for the lowest data rate was selected for SAR evaluation in 802.11b. Other IEEE 802.11 modes (including 802.11g/n) were not investigated since the average output powers over all channels and data rates were not more than 0.25 dB higher than the tested channel in the lowest data rate of IEEE 802.11b mode.
3. Justification for reduced test configurations for WIFI channels per KDB Publication 248227 D01v01r02 and October 2012 FCC/TCB Meeting Notes for 5 GHz WIFI: Highest average RF output power channel for the lowest data rate was selected for SAR evaluation in 802.11a. Other IEEE 802.11 modes (including 802.11n 20 MHz and 40 MHz bandwidths) were not investigated since the average output powers over all channels and data rates were not more than 0.25 dB higher than the tested channel in the lowest data rate of IEEE 802.11a mode.
4. WIFI transmission was verified using an uncalibrated spectrum analyzer.
5. When the maximum extrapolated peak SAR of the zoom scan for the maximum output channel is >1.6 W/kg or the reported 1g averaged SAR is >0.8 W/kg, SAR testing on other default channels was required.

FCC ID: ZNFVK410	 PCTEST ENGINEERING LABORATORY, INC.	SAR EVALUATION REPORT	 LG	Reviewed by: Quality Manager
Document S/N: OY1406021127.ZNF	Test Dates: 06/02/14 - 06/04/14	DUT Type: Portable Tablet	Page 33 of 47	

11 FCC MULTI-TX AND ANTENNA SAR CONSIDERATIONS

11.1 Introduction

The following procedures adopted from FCC KDB Publication 447498 D01v05 are applicable to handsets with built-in unlicensed transmitters such as 802.11a/b/g/n and Bluetooth devices which may simultaneously transmit with the licensed transmitter.

11.2 Simultaneous Transmission Procedures

This device contains transmitters that may operate simultaneously. Therefore simultaneous transmission analysis is required. Per FCC KDB 447498 D01v05 IV.C.1.iii and IEEE 1528-2013 Section 6.3.4.1.2, simultaneous transmission SAR test exclusion may be applied when the sum of the 1-g SAR for all the simultaneous transmitting antennas in a specific physical test configuration is ≤ 1.6 W/kg. When standalone SAR is not required to be measured, per FCC KDB 447498 D01v05 4.3.2 2), the following equation must be used to estimate the standalone 1g SAR for simultaneous transmission assessment involving that transmitter.



$$\text{Estimated SAR} = \frac{\sqrt{f(\text{GHz})}}{7.5} * \frac{(\text{Max Power of channel, mW})}{\text{Min. Separation Distance, mm}}$$

**Table 11-1
Estimated SAR**

Mode	Frequency	Maximum Allowed Power	Separation Distance (Body)	Estimated SAR (Body)
	[MHz]	[dBm]	[mm]	[W/kg]
Bluetooth	2441	9.00	5*	0.333
Bluetooth	2441	9.00	14	0.119
Bluetooth	2441	9.00	16	0.104

Notes:

- (*) - Per FCC KDB Publication 447498, when the test separation distance is < 5 mm, a distance of 5 mm is applied to determine estimated SAR.
- Per KDB Publication 447498 D01v05, the maximum power of the channel was rounded to the nearest mW before calculation.
- When the test separation distance was > 50 mm, an estimated SAR of 0.4 W/kg was used to determine simultaneous transmission SAR exclusion, for configurations excluded per FCC KDB Publication 447498 D01v05. When the test separation distance was < 50 mm, an estimated SAR was determined per FCC KDB Publication 447498 D01v05.

FCC ID: ZNFVK410	 PCTEST ENGINEERING LABORATORY, INC.	SAR EVALUATION REPORT	 LG	Reviewed by: Quality Manager
Document S/N: OY1406021127.ZNF	Test Dates: 06/02/14 - 06/04/14	DUT Type: Portable Tablet		Page 34 of 47

11.3 Body Simultaneous Transmission Analysis

Table 11-2
Simultaneous Transmission Scenario with 2.4 GHz WLAN (Body at 0.0 cm)

Simult Tx	Configuration	LTE Band 13 SAR (W/kg)	2.4 GHz WLAN SAR (W/kg)	Σ SAR (W/kg)
Body SAR	Back	0.613	0.431	1.044
	Top	0.244	0.189	0.433
	Bottom	0.400	0.400	0.800
	Right	0.362	0.400	0.762
	Left	0.711	0.275	0.986

Simult Tx	Configuration	LTE Band 4 (AWS) SAR (W/kg)	2.4 GHz WLAN SAR (W/kg)	Σ SAR (W/kg)
Body SAR	Back	0.595	0.431	1.026
	Top	0.173	0.189	0.362
	Bottom	0.400	0.400	0.800
	Right	0.187	0.400	0.587
	Left	0.473	0.275	0.748



FCC ID: ZNFVK410	 PCTEST ENGINEERING LABORATORY, INC.	SAR EVALUATION REPORT	 LG	Reviewed by: Quality Manager
Document S/N: 0Y1406021127.ZNF	Test Dates: 06/02/14 - 06/04/14	DUT Type: Portable Tablet	Page 35 of 47	

Table 11-3
Simultaneous Transmission Scenario with 5 GHz WLAN (Body at 0.0 cm)

Simult Tx	Configuration	LTE Band 13 SAR (W/kg)	5 GHz WLAN SAR (W/kg)	Σ SAR (W/kg)
Body SAR	Back	0.613	0.651	1.264
	Top	0.244	0.244	0.488
	Bottom	0.400	0.400	0.800
	Right	0.362	0.400	0.762
	Left	0.711	0.315	1.026

Simult Tx	Configuration	LTE Band 4 (AWS) SAR (W/kg)	5 GHz WLAN SAR (W/kg)	Σ SAR (W/kg)
Body SAR	Back	0.595	0.651	1.246
	Top	0.173	0.244	0.417
	Bottom	0.400	0.400	0.800
	Right	0.187	0.400	0.587
	Left	0.473	0.315	0.788



FCC ID: ZNFVK410		SAR EVALUATION REPORT		Reviewed by: Quality Manager
Document S/N: OY1406021127.ZNF	Test Dates: 06/02/14 - 06/04/14	DUT Type: Portable Tablet	Page 36 of 47	

Table 11-4
Simultaneous Transmission Scenario with 2.4 GHz Bluetooth (Body at 0.0 cm)

Simult Tx	Configuration	LTE Band 13 SAR (W/kg)	Bluetooth SAR (W/kg)	Σ SAR (W/kg)
Body SAR	Back	0.613	0.333	0.946
	Top	0.244	0.333	0.577
	Bottom	0.400	0.400	0.800
	Right	0.362	0.400	0.762
	Left	0.711	0.333	1.044

Simult Tx	Configuration	LTE Band 4 (AWS) SAR (W/kg)	Bluetooth SAR (W/kg)	Σ SAR (W/kg)
Body SAR	Back	0.595	0.333	0.928
	Top	0.173	0.333	0.506
	Bottom	0.400	0.400	0.800
	Right	0.187	0.400	0.587
	Left	0.473	0.333	0.806

Note: Bluetooth SAR was not required to be measured per FCC KDB 447498. Estimated SAR results were used in the above table to determine simultaneous transmission SAR test exclusion.



FCC ID: ZNFVK410		SAR EVALUATION REPORT		Reviewed by: Quality Manager
Document S/N: 0Y1406021127.ZNF	Test Dates: 06/02/14 - 06/04/14	DUT Type: Portable Tablet		Page 37 of 47

Table 11-5
Simultaneous Transmission Scenario with 2.4 GHz WLAN (Body at 1.4 cm)

Configuration	Mode	LTE SAR (W/kg)	2.4 GHz WLAN SAR (W/kg)	Σ SAR (W/kg)
Back Side	LTE Band 13	0.317	< 0.431	< 0.748
Back Side	LTE Band 4 (AWS)	0.469	< 0.431	< 0.900

Table 11-6
Simultaneous Transmission Scenario with 5 GHz WLAN (Body at 1.4 cm)

Configuration	Mode	LTE SAR (W/kg)	5 GHz WLAN SAR (W/kg)	Σ SAR (W/kg)
Back Side	LTE Band 13	0.317	< 0.651	< 0.968
Back Side	LTE Band 4 (AWS)	0.469	< 0.651	< 1.120

Table 11-7
Simultaneous Transmission Scenario with 2.4 GHz Bluetooth (Body at 1.4 cm)

Configuration	Mode	LTE SAR (W/kg)	Bluetooth SAR (W/kg)	Σ SAR (W/kg)
Back Side	LTE Band 13	0.317	0.119	0.436
Back Side	LTE Band 4 (AWS)	0.469	0.119	0.588

Note: Bluetooth SAR was not required to be measured per FCC KDB 447498. Estimated SAR results were used in the above table to determine simultaneous transmission SAR test exclusion.



FCC ID: ZNFVK410		SAR EVALUATION REPORT		Reviewed by: Quality Manager
Document S/N: 0Y1406021127.ZNF	Test Dates: 06/02/14 - 06/04/14	DUT Type: Portable Tablet		Page 38 of 47

Table 11-8
Simultaneous Transmission Scenario with 2.4 GHz WLAN (Body at 1.6 cm)

Configuration	Mode	LTE SAR (W/kg)	2.4 GHz WLAN SAR (W/kg)	Σ SAR (W/kg)
Top Edge	LTE Band 13	0.106	< 0.189	< 0.295
Top Edge	LTE Band 4 (AWS)	0.344	< 0.189	< 0.533

Table 11-9
Simultaneous Transmission Scenario with 5 GHz WLAN (Body at 1.6 cm)

Configuration	Mode	LTE SAR (W/kg)	5 GHz WLAN SAR (W/kg)	Σ SAR (W/kg)
Top Edge	LTE Band 13	0.106	< 0.244	< 0.350
Top Edge	LTE Band 4 (AWS)	0.344	< 0.244	< 0.588

Table 11-10
Simultaneous Transmission Scenario with 2.4 GHz Bluetooth (Body at 1.6 cm)

Configuration	Mode	LTE SAR (W/kg)	Bluetooth SAR (W/kg)	Σ SAR (W/kg)
Top Edge	LTE Band 13	0.106	0.104	0.210
Top Edge	LTE Band 4 (AWS)	0.344	0.104	0.448



FCC ID: ZNFVK410		SAR EVALUATION REPORT		Reviewed by: Quality Manager
Document S/N: OY1406021127.ZNF	Test Dates: 06/02/14 - 06/04/14	DUT Type: Portable Tablet	Page 39 of 47	

Table 11-11
Simultaneous Transmission Scenario with 2.4 GHz WLAN (Body at 0.7 cm)

Configuration	Mode	LTE SAR (W/kg)	2.4 GHz WLAN SAR (W/kg)	Σ SAR (W/kg)
Right Edge	LTE Band 13	0.240	0.400	0.640
Right Edge	LTE Band 4 (AWS)	0.770	0.400	1.170

Table 11-12
Simultaneous Transmission Scenario with 5 GHz WLAN (Body at 0.7 cm)

Configuration	Mode	LTE SAR (W/kg)	5 GHz WLAN SAR (W/kg)	Σ SAR (W/kg)
Right Edge	LTE Band 13	0.240	0.400	0.640
Right Edge	LTE Band 4 (AWS)	0.770	0.400	1.170

Table 11-13
Simultaneous Transmission Scenario with 2.4 GHz Bluetooth (Body at 0.7 cm)



Configuration	Mode	LTE SAR (W/kg)	Bluetooth SAR (W/kg)	Σ SAR (W/kg)
Right Edge	LTE Band 13	0.240	0.400	0.640
Right Edge	LTE Band 4 (AWS)	0.770	0.400	1.170

Notes:

1. When the test separation distance was > 50 mm, an estimated SAR of 0.4 W/kg was used to determine simultaneous transmission SAR exclusion, for configuration excluded per FCC KDB 447498 D01v05. Therefore, an estimated SAR of 0.4 W/kg for 2.4 GHz WLAN, 5 GHz WLAN, and Bluetooth was used to evaluate the simultaneous sums.
2. For body SAR summations for back side at 1.4 cm and top edge at 1.6 cm, 2.4 GHz WLAN and 5 GHz WLAN SAR values for 0.0 cm were used since the 0.0 cm test distance for 2.4 GHz WLAN and 5 GHz WLAN were more conservative. "<" denotes that the 0.0 cm 2.4 GHz WLAN and 5 GHz WLAN SAR values were used for summation purposes.

11.4 Simultaneous Transmission Conclusion

The above numerical summed SAR results for all the worst-case simultaneous transmission conditions were below the SAR limit. Therefore, the above analysis is sufficient to determine that simultaneous transmission cases will not exceed the SAR limit and therefore no measured volumetric simultaneous SAR summation is required per FCC KDB Publication 447498 D01v05 and IEEE 1528-2013 Section 6.3.4.1.2.

FCC ID: ZNFVK410		SAR EVALUATION REPORT		Reviewed by: Quality Manager
Document S/N: OY1406021127.ZNF	Test Dates: 06/02/14 - 06/04/14	DUT Type: Portable Tablet		Page 40 of 47



12 SAR MEASUREMENT VARIABILITY

12.1 Measurement Variability

Per FCC KDB Publication 865664 D01v01, all measured SAR values were <0.8 W/kg. Therefore, no SAR measurement variability analysis was required.

12.2 Measurement Uncertainty



The measured SAR was <1.5 W/kg for all frequency bands. Therefore, per KDB Publication 865664 D01v01, the extended measurement uncertainty analysis per IEEE 1528-2003 was not required.

FCC ID: ZNFVK410		SAR EVALUATION REPORT		Reviewed by: Quality Manager
Document S/N: 0Y1406021127.ZNF	Test Dates: 06/02/14 - 06/04/14	DUT Type: Portable Tablet		Page 41 of 47

13 EQUIPMENT LIST

Manufacturer	Model	Description	Cal Date	Cal Interval	Cal Due	Serial Number
Agilent	8594A	(9kHz-2.9GHz) Spectrum Analyzer	N/A	N/A	N/A	3051A00187
Agilent	8648D	(9kHz-4GHz) Signal Generator	4/15/2014	Annual	4/15/2015	3629U00687
Agilent	8753E	(30kHz-6GHz) Network Analyzer	7/23/2013	Annual	7/23/2014	US37390350
Agilent	8753ES	S-Parameter Network Analyzer	10/29/2013	Annual	10/29/2014	US39170122
Agilent	E4438C	ESG Vector Signal Generator	4/1/2014	Annual	4/1/2015	MY47270002
Agilent	E8257D	(250kHz-20GHz) Signal Generator	4/15/2014	Annual	4/15/2015	MY45470194
Agilent	N5182A	MXG Vector Signal Generator	4/15/2014	Annual	4/15/2015	MY47420800
Amplifier Research	15S1G6	Amplifier	CBT	N/A	CBT	433971
Amplifier Research	15S1G6	Amplifier	CBT	N/A	CBT	433974
Anritsu	MA24106A	USB Power Sensor	1/3/2014	Annual	1/3/2015	1349509
Anritsu	MA24106A	USB Power Sensor	1/3/2014	Annual	1/3/2015	1349514
Anritsu	MA2411B	Pulse Power Sensor	3/25/2014	Annual	3/25/2015	1207470
Anritsu	MA2411B	Pulse Power Sensor	2/3/2014	Annual	2/3/2015	1339018
Anritsu	MA2481A	Power Sensor	10/30/2013	Annual	10/30/2014	5605
Anritsu	ML2469A	Power Meter	3/14/2014	Annual	3/14/2015	1306009
Anritsu	ML2495A	Power Meter	10/31/2013	Annual	10/31/2014	1039008
COMTECH	AR85729-5	Solid State Amplifier	CBT	N/A	CBT	M1S5A00-009
COMTECH	AR85729-5/5759B	Solid State Amplifier	CBT	N/A	CBT	M3W1A00-1002
Fisher Scientific	15-077-960	Digital Thermometer	12/4/2013	Biennial	12/4/2015	130764558
Fisher Scientific	15-078J	Long Stem Thermometer	10/30/2012	Biennial	10/30/2014	122626059
Fisher Scientific	S97611	Thermometer	4/12/2013	Biennial	4/12/2015	130219304
MCL	BW-N6W5+	6dB Attenuator	CBT	N/A	CBT	1139
MiniCircuits	SLP-2400+	Low Pass Filter	CBT	N/A	CBT	R8979500903
MiniCircuits	VLF-6000+	Low Pass Filter	CBT	N/A	CBT	N/A
MiniCircuits	VLF-6000+	Low Pass Filter	CBT	N/A	CBT	N/A
Mini-Circuits	BW-N20W5	Power Attenuator	CBT	N/A	CBT	1226
Mini-Circuits	BW-N20W5+	DC to 18 GHz Precision Fixed 20 dB Attenuator	CBT	N/A	CBT	N/A
Mini-Circuits	NLP-1200+	Low Pass Filter DC to 1000 MHz	CBT	N/A	CBT	N/A
Mini-Circuits	NLP-2950+	Low Pass Filter DC to 2700 MHz	CBT	N/A	CBT	N/A
Mitutoyo	CD-6"CSX	Digital Caliper	5/8/2014	Biennial	5/8/2016	13264162
Mitutoyo	CD-6"CSX	Digital Caliper	5/8/2014	Biennial	5/8/2016	13264165
Narda	4014C-6	4 - 8 GHz SMA 6 dB Directional Coupler	CBT	N/A	CBT	N/A
Narda	4772-3	Attenuator (3dB)	CBT	N/A	CBT	9406
Narda	BW-S3W2	Attenuator (3dB)	CBT	N/A	CBT	120
Pasternack	PE2208-6	Bidirectional Coupler	CBT	N/A	CBT	N/A
Pasternack	PE2209-10	Bidirectional Coupler	CBT	N/A	CBT	N/A
Rohde & Schwarz	CMW500	LTE Radio Communication Tester	10/18/2013	Annual	10/18/2014	100976
Seekonk	NC-100	Torque Wrench	3/18/2014	Biennial	3/18/2016	22313
Seekonk	NC-100	Torque Wrench 5/16", 8" lbs	3/18/2014	Biennial	3/18/2016	N/A
Seekonk	NC-100	Torque Wrench	3/18/2014	Biennial	3/18/2016	N/A
SPEAG	D1750V2	1750 MHz SAR Dipole	4/10/2014	Annual	4/10/2015	1051
SPEAG	D2450V2	2450 MHz SAR Dipole	8/23/2013	Annual	8/23/2014	719
SPEAG	D5GHzV2	5 GHz SAR Dipole	9/23/2013	Annual	9/23/2014	1007
SPEAG	D750V3	750 MHz Dipole	1/20/2014	Annual	1/20/2015	1003
SPEAG	DAE4	Dasy Data Acquisition Electronics	12/12/2013	Annual	12/12/2014	649
SPEAG	DAE4	Dasy Data Acquisition Electronics	2/26/2014	Annual	2/26/2015	665
SPEAG	DAE4	Dasy Data Acquisition Electronics	11/18/2013	Annual	11/18/2014	1407
SPEAG	DAE4	Dasy Data Acquisition Electronics	11/19/2013	Annual	11/19/2014	1408
SPEAG	DAK-3.5	Dielectric Assessment Kit	5/6/2014	Annual	5/6/2015	1070
SPEAG	DAKS-3.5	Portable Dielectric Assessment Kit	8/18/2013	Annual	8/18/2014	1009
SPEAG	ES3DV3	SAR Probe	2/25/2014	Annual	2/25/2015	3258
SPEAG	ES3DV3	SAR Probe	11/25/2013	Annual	11/25/2014	3332
SPEAG	ES3DV3	SAR Probe	11/22/2013	Annual	11/22/2014	3333
SPEAG	EX3DV4	SAR Probe	12/18/2013	Annual	12/18/2014	3920
Tektronix	RSA6114A	Real Time Spectrum Analyzer	4/16/2014	Annual	4/16/2015	B010177
VWR	23226-658	Long Stem Thermometer	6/27/2012	Biennial	6/27/2014	122363923
VWR	36934-158	Wall-Mounted Thermometer	4/29/2014	Biennial	4/29/2016	111859323

Note: CBT (Calibrated Before Testing). Prior to testing, the measurement paths containing a cable, amplifier, attenuator, coupler or filter were connected to a calibrated source (i.e. a signal generator) to determine the losses of the measurement path. The power meter offset was then adjusted to compensate for the measurement system losses. This level offset is stored within the power meter before measurements are made. This calibration verification procedure applies to the system verification and output power measurements. The calibrated reading is then taken directly from the power meter after compensation of the losses for all final power measurements.



FCC ID: ZNFVK410		SAR EVALUATION REPORT		Reviewed by: Quality Manager
Document S/N: OY1406021127.ZNF	Test Dates: 06/02/14 - 06/04/14	DUT Type: Portable Tablet		Page 42 of 47

14 MEASUREMENT UNCERTAINTIES

Applicable for frequencies less than 3000 MHz.

a	b	c	d	e= f(d,k)	f	g	h = c x f/e	i = c x g/e	k
Uncertainty Component	IEEE 1528 Sec.	Tol. (± %)	Prob. Dist.	Div.	c _i 1gm	c _i 10gms	1gm u _i (± %)	10gms u _i (± %)	v _i
Measurement System									
Probe Calibration	E.2.1	6.0	N	1	1.0	1.0	6.0	6.0	∞
Axial Isotropy	E.2.2	0.25	N	1	0.7	0.7	0.2	0.2	∞
Hemishperical Isotropy	E.2.2	1.3	N	1	1.0	1.0	1.3	1.3	∞
Boundary Effect	E.2.3	0.4	N	1	1.0	1.0	0.4	0.4	∞
Linearity	E.2.4	0.3	N	1	1.0	1.0	0.3	0.3	∞
System Detection Limits	E.2.5	5.1	N	1	1.0	1.0	5.1	5.1	∞
Readout Electronics	E.2.6	1.0	N	1	1.0	1.0	1.0	1.0	∞
Response Time	E.2.7	0.8	R	1.73	1.0	1.0	0.5	0.5	∞
Integration Time	E.2.8	2.6	R	1.73	1.0	1.0	1.5	1.5	∞
RF Ambient Conditions	E.6.1	3.0	R	1.73	1.0	1.0	1.7	1.7	∞
Probe Positioner Mechanical Tolerance	E.6.2	0.4	R	1.73	1.0	1.0	0.2	0.2	∞
Probe Positioning w/ respect to Phantom	E.6.3	2.9	R	1.73	1.0	1.0	1.7	1.7	∞
Extrapolation, Interpolation & Integration algorithms for Max. SAR Evaluation	E.5	1.0	R	1.73	1.0	1.0	0.6	0.6	∞
Test Sample Related									
Test Sample Positioning	E.4.2	6.0	N	1	1.0	1.0	6.0	6.0	287
Device Holder Uncertainty	E.4.1	3.32	R	1.73	1.0	1.0	1.9	1.9	∞
Output Power Variation - SAR drift measurement	6.6.2	5.0	R	1.73	1.0	1.0	2.9	2.9	∞
Phantom & Tissue Parameters									
Phantom Uncertainty (Shape & Thickness tolerances)	E.3.1	4.0	R	1.73	1.0	1.0	2.3	2.3	∞
Liquid Conductivity - deviation from target values	E.3.2	5.0	R	1.73	0.64	0.43	1.8	1.2	∞
Liquid Conductivity - measurement uncertainty	E.3.3	3.8	N	1	0.64	0.43	2.4	1.6	6
Liquid Permittivity - deviation from target values	E.3.2	5.0	R	1.73	0.60	0.49	1.7	1.4	∞
Liquid Permittivity - measurement uncertainty	E.3.3	4.5	N	1	0.60	0.49	2.7	2.2	6
Combined Standard Uncertainty (k=1)				RSS			12.1	11.7	299
Expanded Uncertainty (95% CONFIDENCE LEVEL)				k=2			24.2	23.5	



The above measurement uncertainties are according to IEEE Std. 1528-2003

FCC ID: ZNFVK410	 PCTEST ENGINEERING LABORATORY, INC.	SAR EVALUATION REPORT			Reviewed by: Quality Manager
Document S/N: OY1406021127.ZNF	Test Dates: 06/02/14 - 06/04/14	DUT Type: Portable Tablet			Page 43 of 47

Applicable for frequencies up to 6 GHz.

a	b	c	d	e= f(d,k)	f	g	h= c x f/e	i= c x g/e	k	
Uncertainty Component	IEEE 1528 Sec.	Tol. (± %)	Prob. Dist.	Div.	c _i 1gm	c _i 10 gms	1gm u _i (± %)	10gms u _i (± %)	v _i	
Measurement System										
Probe Calibration	E.2.1	6.55	N	1	1.0	1.0	6.6	6.6	∞	
Axial Isotropy	E.2.2	0.25	N	1	0.7	0.7	0.2	0.2	∞	
Hemishperical Isotropy	E.2.2	1.3	N	1	1.0	1.0	1.3	1.3	∞	
Boundary Effect	E.2.3	0.4	N	1	1.0	1.0	0.4	0.4	∞	
Linearity	E.2.4	0.3	N	1	1.0	1.0	0.3	0.3	∞	
System Detection Limits	E.2.5	5.1	N	1	1.0	1.0	5.1	5.1	∞	
Readout Electronics	E.2.6	1.0	N	1	1.0	1.0	1.0	1.0	∞	
Response Time	E.2.7	0.8	R	1.73	1.0	1.0	0.5	0.5	∞	
Integration Time	E.2.8	2.6	R	1.73	1.0	1.0	1.5	1.5	∞	
RF Ambient Conditions	E.6.1	3.0	R	1.73	1.0	1.0	1.7	1.7	∞	
Probe Positioner Mechanical Tolerance	E.6.2	0.4	R	1.73	1.0	1.0	0.2	0.2	∞	
Probe Positioning w/ respect to Phantom	E.6.3	2.9	R	1.73	1.0	1.0	1.7	1.7	∞	
Extrapolation, Interpolation & Integration algorithms for Max. SAR Evaluation	E.5	1.0	R	1.73	1.0	1.0	0.6	0.6	∞	
Test Sample Related										
Test Sample Positioning	E.4.2	6.0	N	1	1.0	1.0	6.0	6.0	287	
Device Holder Uncertainty	E.4.1	3.32	R	1.73	1.0	1.0	1.9	1.9	∞	
Output Power Variation - SAR drift measurement	6.6.2	5.0	R	1.73	1.0	1.0	2.9	2.9	∞	
Phantom & Tissue Parameters										
Phantom Uncertainty (Shape & Thickness tolerances)	E.3.1	4.0	R	1.73	1.0	1.0	2.3	2.3	∞	
Liquid Conductivity - deviation from target values	E.3.2	5.0	R	1.73	0.64	0.43	1.8	1.2	∞	
Liquid Conductivity - measurement uncertainty	E.3.3	3.8	N	1	0.64	0.43	2.4	1.6	6	
Liquid Permittivity - deviation from target values	E.3.2	5.0	R	1.73	0.60	0.49	1.7	1.4	∞	
Liquid Permittivity - measurement uncertainty	E.3.3	4.5	N	1	0.60	0.49	2.7	2.2	6	
Combined Standard Uncertainty (k=1)							RSS	12.4	12.0	299
Expanded Uncertainty (95% CONFIDENCE LEVEL)							k=2	24.7	24.0	

The above measurement uncertainties are according to IEEE Std. 1528-2003



FCC ID: ZNFVK410	 PCTEST ENGINEERING LABORATORY, INC.	SAR EVALUATION REPORT		Reviewed by: Quality Manager
Document S/N: OY1406021127.ZNF	Test Dates: 06/02/14 - 06/04/14	DUT Type: Portable Tablet		Page 44 of 47

15 CONCLUSION

15.1 Measurement Conclusion



The SAR evaluation indicates that the EUT complies with the RF radiation exposure limits of the FCC and Industry Canada, with respect to all parameters subject to this test. These measurements were taken to simulate the RF effects of RF exposure under worst-case conditions. Precise laboratory measures were taken to assure repeatability of the tests. The results and statements relate only to the item(s) tested.

Please note that the absorption and distribution of electromagnetic energy in the body are very complex phenomena that depend on the mass, shape, and size of the body, the orientation of the body with respect to the field vectors, and the electrical properties of both the body and the environment. Other variables that may play a substantial role in possible biological effects are those that characterize the environment (e.g. ambient temperature, air velocity, relative humidity, and body insulation) and those that characterize the individual (e.g. age, gender, activity level, debilitation, or disease). Because various factors may interact with one another to vary the specific biological outcome of an exposure to electromagnetic fields, any protection guide should consider maximal amplification of biological effects as a result of field-body interactions, environmental conditions, and physiological variables. [3]



FCC ID: ZNFVK410		SAR EVALUATION REPORT		Reviewed by: Quality Manager
Document S/N: 0Y1406021127.ZNF	Test Dates: 06/02/14 - 06/04/14	DUT Type: Portable Tablet		Page 45 of 47

16 REFERENCES

- [1] Federal Communications Commission, ET Docket 93-62, Guidelines for Evaluating the Environmental Effects of Radiofrequency Radiation, Aug. 1996.
- [2] ANSI/IEEE C95.1-2005, American National Standard safety levels with respect to human exposure to radio frequency electromagnetic fields, 3kHz to 300GHz, New York: IEEE, 2006.
- [3] ANSI/IEEE C95.1-1992, American National Standard safety levels with respect to human exposure to radio frequency electromagnetic fields, 3kHz to 300GHz, New York: IEEE, Sept. 1992.
- [4] ANSI/IEEE C95.3-2002, IEEE Recommended Practice for the Measurement of Potentially Hazardous Electromagnetic Fields - RF and Microwave, New York: IEEE, December 2002.
- [5] IEEE Standards Coordinating Committee 39 –Standards Coordinating Committee 34 – IEEE Std. 1528-2003, Recommended Practice for Determining the Peak Spatial-Average Specific Absorption Rate (SAR) in the Human Body Due to Wireless Communications Devices.
- [6] NCRP, National Council on Radiation Protection and Measurements, Biological Effects and Exposure Criteria for RadioFrequency Electromagnetic Fields, NCRP Report No. 86, 1986. Reprinted Feb. 1995.
- [7] T. Schmid, O. Egger, N. Kuster, Automated E-field scanning system for dosimetric assessments, IEEE Transaction on Microwave Theory and Techniques, vol. 44, Jan. 1996, pp. 105-113.
- [8] K. Pokovic, T. Schmid, N. Kuster, Robust setup for precise calibration of E-field probes in tissue simulating liquids at mobile communications frequencies, ICECOM97, Oct. 1997, pp. -124.
- [9] K. Pokovic, T. Schmid, and N. Kuster, E-field Probe with improved isotropy in brain simulating liquids, Proceedings of the ELMAR, Zadar, Croatia, June 23-25, 1996, pp. 172-175.
- [10] Schmid & Partner Engineering AG, Application Note: Data Storage and Evaluation, June 1998, p2.
- [11] V. Hombach, K. Meier, M. Burkhardt, E. Kuhn, N. Kuster, The Dependence of EM Energy Absorption upon Human Modeling at 900 MHz, IEEE Transaction on Microwave Theory and Techniques, vol. 44 no. 10, Oct. 1996, pp. 1865-1873.
- [12] N. Kuster and Q. Balzano, Energy absorption mechanism by biological bodies in the near field of dipole antennas above 300MHz, IEEE Transaction on Vehicular Technology, vol. 41, no. 1, Feb. 1992, pp. 17-23.
- [13] G. Hartsgrrove, A. Kraszewski, A. Surowiec, Simulated Biological Materials for Electromagnetic Radiation Absorption Studies, University of Ottawa, Bioelectromagnetics, Canada: 1987, pp. 29-36.
- [14] Q. Balzano, O. Garay, T. Manning Jr., Electromagnetic Energy Exposure of Simulated Users of Portable Cellular Telephones, IEEE Transactions on Vehicular Technology, vol. 44, no.3, Aug. 1995.
- [15] W. Gander, Computermathematick, Birkhaeuser, Basel, 1992.
- [16] W.H. Press, S.A. Teukolsky, W.T. Vetterling, and B.P. Flannery, Numerical Recipes in C, The Art of Scientific Computing, Second edition, Cambridge University Press, 1992.
- [17] N. Kuster, R. Kastle, T. Schmid, Dosimetric evaluation of mobile communications equipment with known precision, IEEE Transaction on Communications, vol. E80-B, no. 5, May 1997, pp. 645-652.

FCC ID: ZNFVK410	 PCTEST ENGINEERING LABORATORY, INC.	SAR EVALUATION REPORT	 LG	Reviewed by: Quality Manager
Document S/N: OY1406021127.ZNF	Test Dates: 06/02/14 - 06/04/14	DUT Type: Portable Tablet	Page 46 of 47	

- [18] CENELEC CLC/SC111B, European Prestandard (prENV 50166-2), Human Exposure to Electromagnetic Fields High-frequency: 10kHz-300GHz, Jan. 1995.
- [19] Prof. Dr. Niels Kuster, ETH, Eidgenössische Technische Hochschule Zürich, Dosimetric Evaluation of the Cellular Phone.
- [20] IEC 62209-1, Human exposure to radio frequency fields from hand-held and body-mounted wireless communication devices - Human models, instrumentation, and procedures - Part 1: Procedure to determine the specific absorption rate (SAR) for hand-held devices used in close proximity to the ear (frequency range of 300 MHz to 3 GHz), Feb. 2005.
- [21] Industry Canada RSS-102 Radio Frequency Exposure Compliance of Radiocommunication Apparatus (All Frequency Bands) Issue 4, March 2010.
- [22] Health Canada Safety Code 6 Limits of Human Exposure to Radio Frequency Electromagnetic Fields in the Frequency Range from 3 kHz – 300 GHz, 2009
- [23] FCC SAR Test Procedures for 2G-3G Devices, Mobile Hotspot and UMPC Devices KDB Publications 941225, D01-D07
- [24] SAR Measurement procedures for IEEE 802.11a/b/g KDB Publication 248227 D01v01r02
- [25] FCC SAR Considerations for Handsets with Multiple Transmitters and Antennas, KDB Publications 648474 D02-D04
- [26] FCC SAR Evaluation Considerations for Laptop, Notebook, Netbook and Tablet Computers, FCC KDB Publication 616217 D04
- [27] FCC SAR Measurement and Reporting Requirements for 100MHz – 6 GHz, KDB Publications 865664 D01-D02
- [28] FCC General RF Exposure Guidance and SAR Procedures for Dongles, KDB Publication 447498, D01-D02
- [29] Anexo à Resolução No. 533, de 10 de Setembro de 2009.
- [30] IEC 62209-2, Human exposure to radio frequency fields from hand-held and body-mounted wireless communication devices - Human models, instrumentation, and procedures - Part 2: Procedure to determine the specific absorption rate (SAR) for wireless communication devices used in close proximity to the human body (frequency range of 30 MHz to 6 GHz), Mar. 2010.

FCC ID: ZNFVK410	 SAR EVALUATION REPORT 		Reviewed by: Quality Manager
Document S/N: OY1406021127.ZNF	Test Dates: 06/02/14 - 06/04/14	DUT Type: Portable Tablet	Page 47 of 47

APPENDIX A: SAR TEST DATA

PCTEST ENGINEERING LABORATORY, INC.

DUT: ZNFVK410; Type: Portable Tablet; Serial: 0206-4

Communication System: UID 0, LTE Band 13; Frequency: 782 MHz; Duty Cycle: 1:1

Medium: 750 Body Medium parameters used (interpolated):

$f = 782 \text{ MHz}$; $\sigma = 1.007 \text{ S/m}$; $\epsilon_r = 55.206$; $\rho = 1000 \text{ kg/m}^3$

Phantom section: Flat Section; Space: 0.0 cm

Test Date: 06-02-2014; Ambient Temp: 23.3°C; Tissue Temp: 23.0°C

Probe: ES3DV3 - SN3332; ConvF(6.21, 6.21, 6.21); Calibrated: 11/25/2013;

Sensor-Surface: 4mm (Mechanical Surface Detection)

Electronics: DAE4 Sn1407; Calibrated: 11/18/2013

Phantom: ELI v5.0; Type: QDOVA001BB; Serial: 1226

Measurement SW: DASY52, Version 52.8 (7); SEMCAD X Version 14.6.10 (7331)

Mode: LTE Band 13, Body SAR, Left Edge, Mid.ch
10 MHz Bandwidth, QPSK, 1 RB, 0 RB Offset

Area Scan (11x17x1): Measurement grid: dx=5mm, dy=15mm

Zoom Scan (5x5x7)/Cube 0: Measurement grid: dx=8mm, dy=8mm, dz=5mm

Reference Value = 27.73 V/m; Power Drift = 0.08 dB

Peak SAR (extrapolated) = 1.18 W/kg

SAR(1 g) = 0.710 W/kg

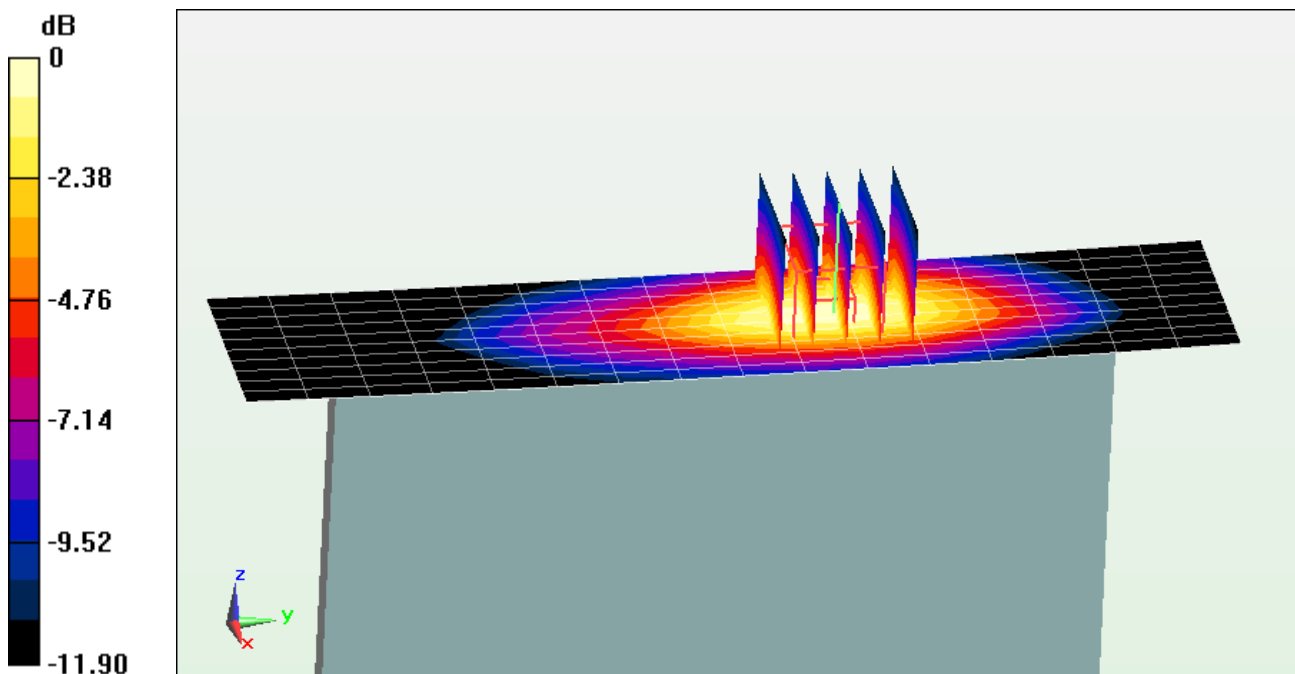

0 dB = 0.796 W/kg = -0.99 dBW/kg

PCTEST ENGINEERING LABORATORY, INC.

DUT: ZNFVK410; Type: Portable Tablet; Serial: 0206-4

Communication System: UID 0, LTE Band 4 (AWS); Frequency: 1732.5 MHz; Duty Cycle: 1:1

Medium: 1750 Body Medium parameters used (interpolated):

$f = 1732.5 \text{ MHz}$; $\sigma = 1.438 \text{ S/m}$; $\epsilon_r = 52.934$; $\rho = 1000 \text{ kg/m}^3$

Phantom section: Flat Section; Space: 0.7 cm

Test Date: 06-04-2014; Ambient Temp: 24.0°C; Tissue Temp: 22.8°C

Probe: ES3DV3 - SN3333; ConvF(4.95, 4.95, 4.95); Calibrated: 11/22/2013;

Sensor-Surface: 4mm (Mechanical Surface Detection)

Electronics: DAE4 Sn1408; Calibrated: 11/19/2013

Phantom: ELI v5.0; Type: QDOVA001BB; Serial: 1229

Measurement SW: DASY52, Version 52.8 (7); SEMCAD X Version 14.6.10 (7331)

Mode: LTE Band 4 (AWS), Body SAR, Right Edge, Mid.ch
20 MHz Bandwidth, QPSK, 1 RB, 0 RB Offset

Area Scan (11x17x1): Measurement grid: dx=5mm, dy=15mm

Zoom Scan (5x5x7)/Cube 0: Measurement grid: dx=8mm, dy=8mm, dz=5mm

Reference Value = 24.39 V/m; Power Drift = 0.04 dB

Peak SAR (extrapolated) = 1.20 W/kg

SAR(1 g) = 0.761 W/kg

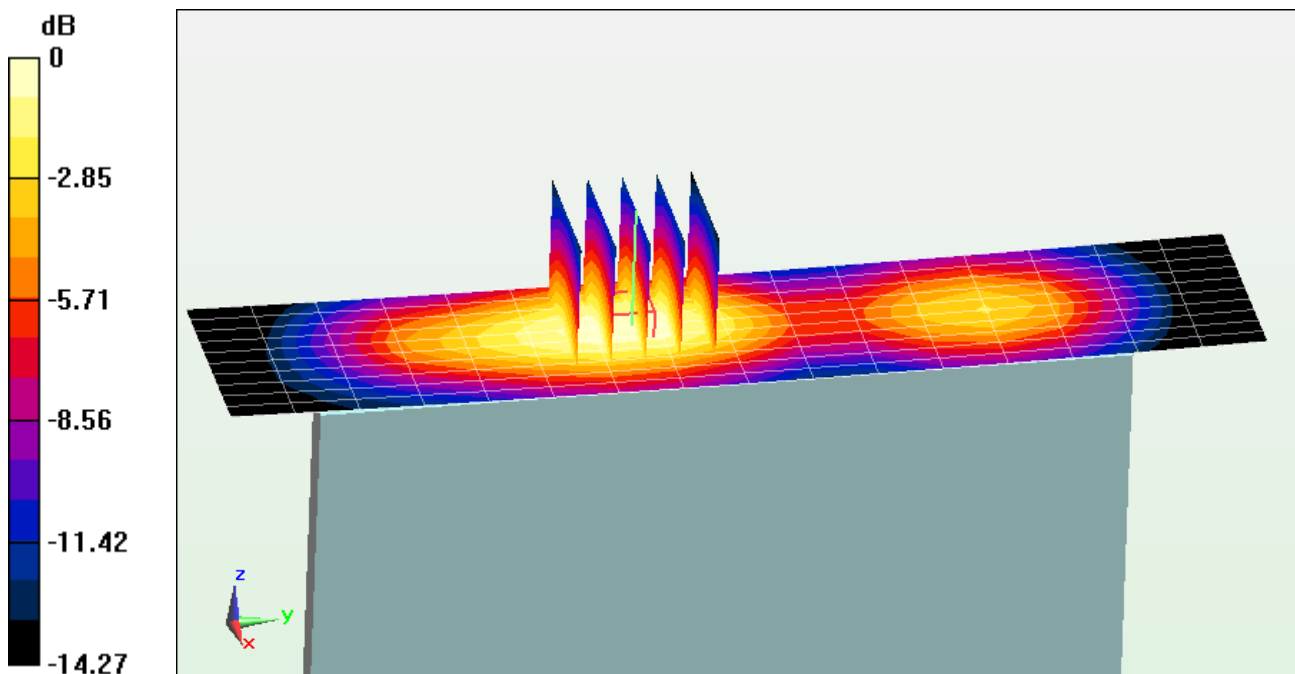

0 dB = 0.832 W/kg = -0.80 dBW/kg

PCTEST ENGINEERING LABORATORY, INC.

DUT: ZNFVK410; Type: Portable Tablet; Serial: 0206-11

Communication System: UID 0, IEEE 802.11b; Frequency: 2462 MHz; Duty Cycle: 1:1

Medium: 2450 Body Medium parameters used (interpolated):

$f = 2462 \text{ MHz}$; $\sigma = 1.968 \text{ S/m}$; $\epsilon_r = 50.994$; $\rho = 1000 \text{ kg/m}^3$

Phantom section: Flat Section; Space: 0.0 cm

Test Date: 06-02-2014; Ambient Temp: 24.5°C; Tissue Temp: 23.0°C

Probe: ES3DV3 - SN3258; ConvF(4.14, 4.14, 4.14); Calibrated: 2/25/2014;

Sensor-Surface: 3mm (Mechanical Surface Detection)

Electronics: DAE4 Sn665; Calibrated: 2/26/2014

Phantom: ELI v5.0; Type: QDOVA002AA; Serial: TP-1158

Measurement SW: DASY52, Version 52.8 (7); SEMCAD X Version 14.6.10 (7331)

Mode: IEEE 802.11b, Body SAR, Ch 11, 1 Mbps, Back Side

Area Scan (14x20x1): Measurement grid: dx=12mm, dy=12mm

Zoom Scan (7x7x7)/Cube 0: Measurement grid: dx=5mm, dy=5mm, dz=5mm

Reference Value = 12.82 V/m; Power Drift = 0.20 dB

Peak SAR (extrapolated) = 0.935 W/kg

SAR(1 g) = 0.383 W/kg

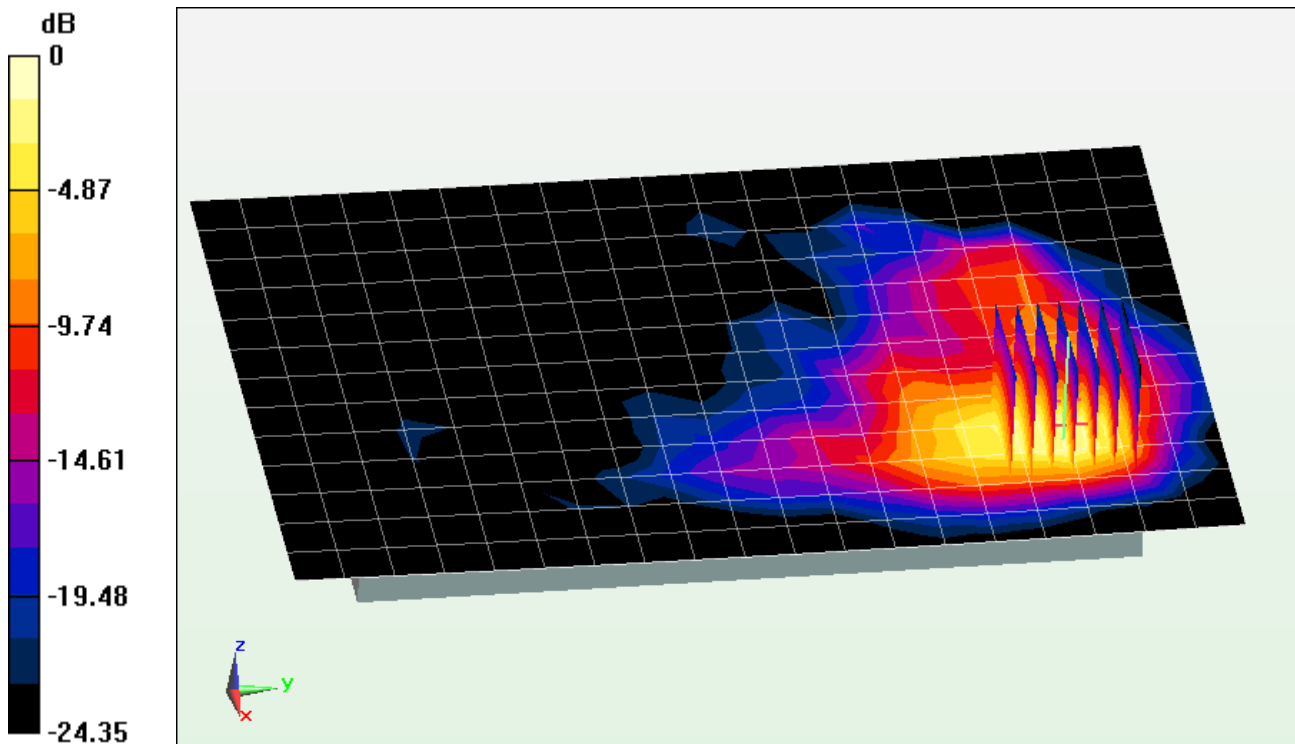

0 dB = 0.511 W/kg = -2.92 dBW/kg

PCTEST ENGINEERING LABORATORY, INC.

DUT: ZNFVK410; Type: Portable Tablet; Serial: 0206-11

Communication System: UID 0, IEEE 802.11a 5.2-5.8 GHz Band; Frequency: 5785 MHz; Duty Cycle: 1:1

Medium: 5 GHz Body Medium parameters used:

$f = 5785 \text{ MHz}$; $\sigma = 5.998 \text{ S/m}$; $\epsilon_r = 46.375$; $\rho = 1000 \text{ kg/m}^3$

Phantom section: Flat Section; Space: 0.0 cm

Test Date: 06-02-2014; Ambient Temp: 24.5°C; Tissue Temp: 24.5°C

Probe: EX3DV4 - SN3920; ConvF(4, 4, 4); Calibrated: 12/18/2013;

Sensor-Surface: 1.4mm (Mechanical Surface Detection)

Electronics: DAE4 Sn649; Calibrated: 12/12/2013

Phantom: SAM Sub; Type: SAM 4.0; Serial: TP-1357

Measurement SW: DASY4, Version 4.7 (80); SEMCAD X Version 14.6.10 (7331)

Mode: IEEE 802.11a, 5.8 GHz, Body SAR, Ch 157, 6 Mbps, Back Side

Area Scan (17x24x1): Measurement grid: dx=10mm, dy=10mm

Zoom Scan (8x8x7)/Cube 0: Measurement grid: dx=4mm, dy=4mm, dz=1.4mm, Graded Ratio=1.4

Reference Value = 3.687 V/m; Power Drift = 0.15 dB

Peak SAR (extrapolated) = 0.848 W/kg

SAR(1 g) = 0.183 W/kg

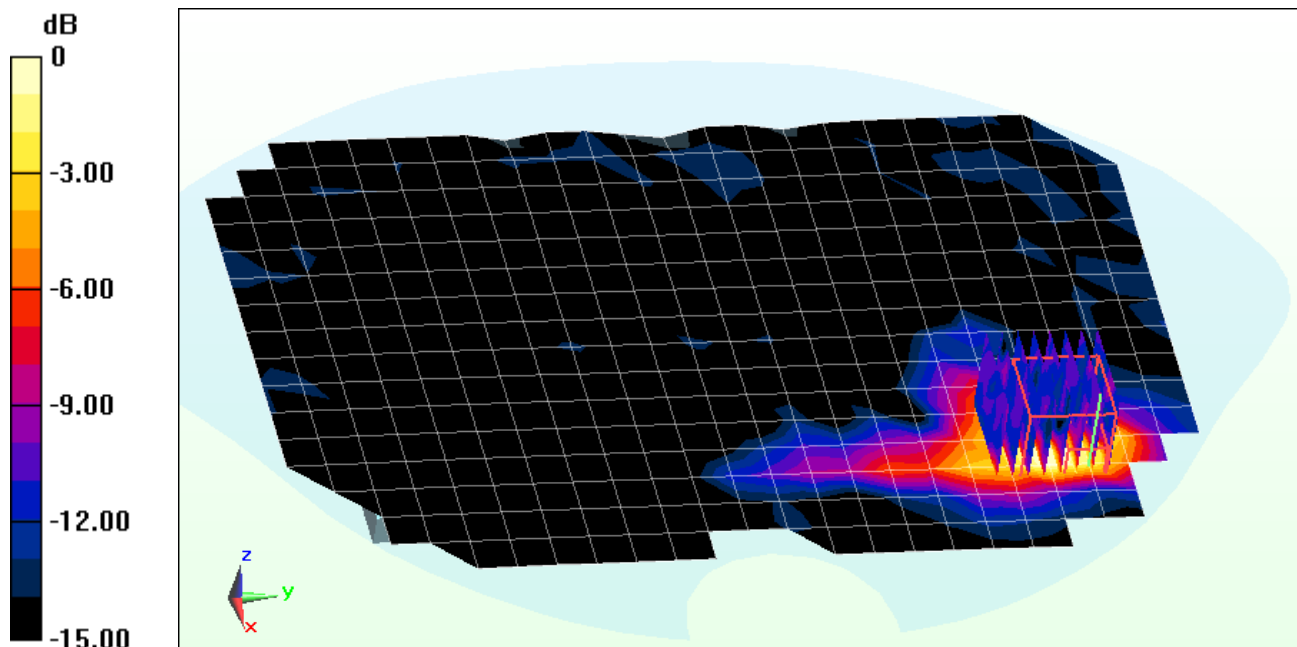

0 dB = 0.435 W/kg = -3.62 dBW/kg

PCTEST ENGINEERING LABORATORY, INC.

DUT: ZNFVK410; Type: Portable Tablet; Serial: 0206-11

Communication System: UID 0, IEEE 802.11a 5.2-5.8 GHz Band; Frequency: 5260 MHz; Duty Cycle: 1:1

Medium: 5 GHz Body Medium parameters used:

$f = 5260 \text{ MHz}$; $\sigma = 5.324 \text{ S/m}$; $\epsilon_r = 47.042$; $\rho = 1000 \text{ kg/m}^3$

Phantom section: Flat Section; Space: 0.0 cm

Test Date: 06-02-2014; Ambient Temp: 24.4°C; Tissue Temp: 24.5°C

Probe: EX3DV4 - SN3920; ConvF(4.11, 4.11, 4.11); Calibrated: 12/18/2013;

Sensor-Surface: 1.4mm (Mechanical Surface Detection)

Electronics: DAE4 Sn649; Calibrated: 12/12/2013

Phantom: SAM Sub; Type: SAM 4.0; Serial: TP-1357

Measurement SW: DASY4, Version 4.7 (80); SEMCAD X Version 14.6.10 (7331)

Mode: IEEE 802.11a, 5.3 GHz, Body SAR, Ch 52, 6 Mbps, Back Side

Area Scan (17x24x1): Measurement grid: dx=10mm, dy=10mm

Zoom Scan (8x8x7)/Cube 0: Measurement grid: dx=4mm, dy=4mm, dz=1.4mm; Graded Ratio=1.4

Reference Value = 7.628 V/m; Power Drift = 0.04 dB

Peak SAR (extrapolated) = 2.29 W/kg

SAR(1 g) = 0.454 W/kg

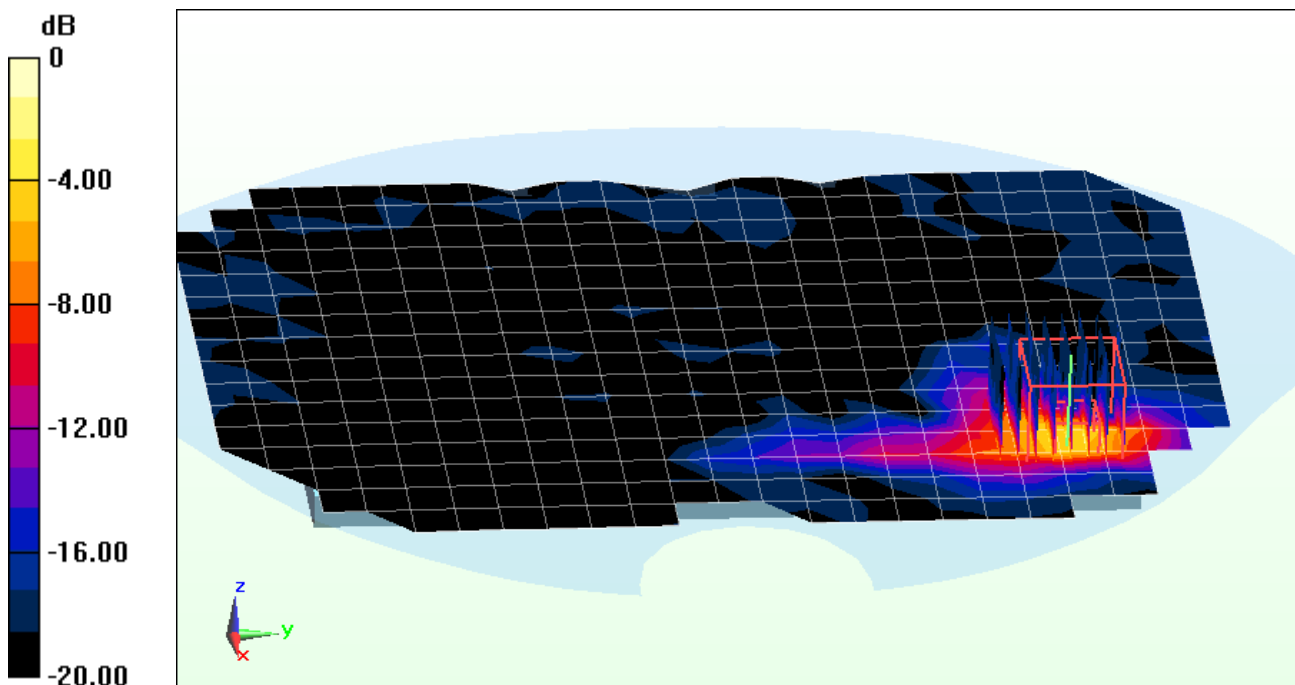

0 dB = 1.16 W/kg = 0.64 dBW/kg

APPENDIX B: SYSTEM VERIFICATION

PCTEST ENGINEERING LABORATORY, INC.

DUT: Dipole 750 MHz; Type: D750V3; Serial: 1003

Communication System: UID 0, CW; Frequency: 750 MHz; Duty Cycle: 1:1

Medium: 740 Body Medium parameters used (interpolated):

$f = 750 \text{ MHz}$; $\sigma = 0.977 \text{ S/m}$; $\epsilon_r = 55.515$; $\rho = 1000 \text{ kg/m}^3$

Phantom section: Flat Section; Space: 1.5 cm

Test Date: 06-02-2014; Ambient Temp: 23.3°C; Tissue Temp: 23.0°C

Probe: ES3DV3 - SN3332; ConvF(6.21, 6.21, 6.21); Calibrated: 11/25/2013;

Sensor-Surface: 4mm (Mechanical Surface Detection)

Electronics: DAE4 Sn1407; Calibrated: 11/18/2013

Phantom: ELI v5.0; Type: QDOVA001BB; Serial: 1226

Measurement SW: DASY52, Version 52.8 (7); SEMCAD X Version 14.6.10 (7331)

750 MHz System Verification

Area Scan (7x15x1): Measurement grid: dx=15mm, dy=15mm

Zoom Scan (5x5x7)/Cube 0: Measurement grid: dx=8mm, dy=8mm, dz=5mm

Input Power = 20 dBm (100 mW)

Peak SAR (extrapolated) = 1.32 W/kg

SAR(1 g) = 0.903 W/kg

Deviation = 2.96 %

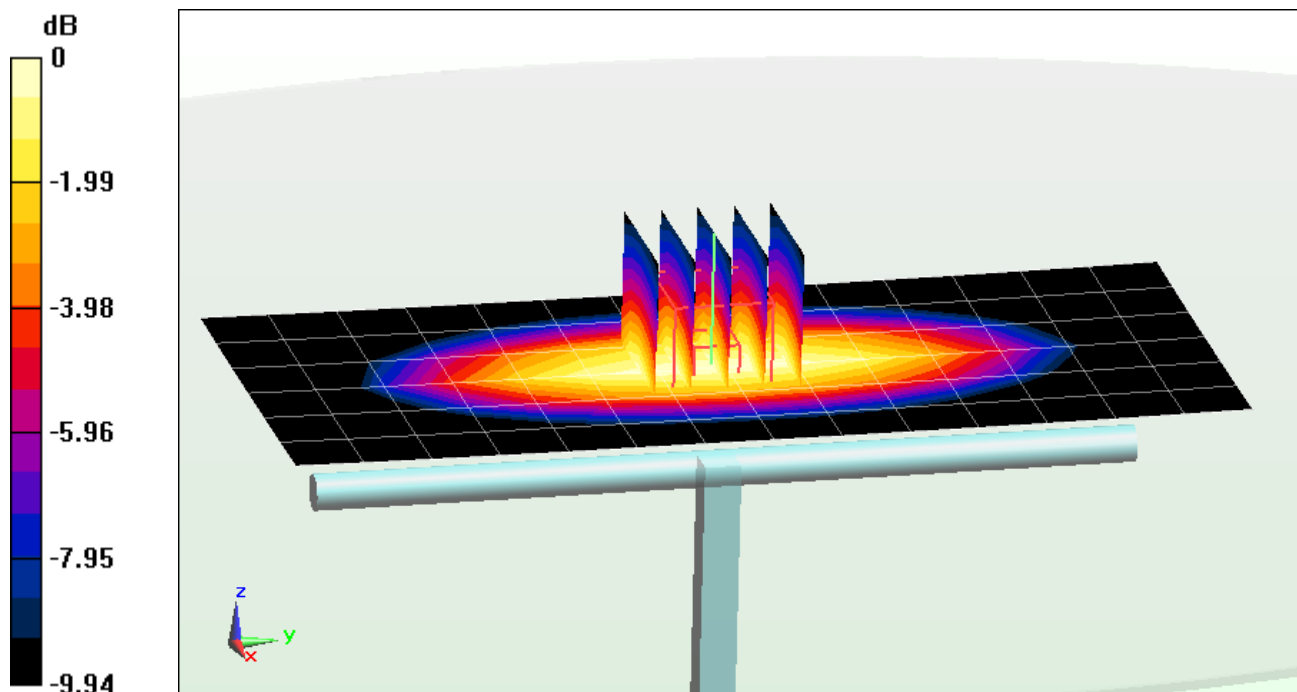

0 dB = 0.973 W/kg = -0.12 dBW/kg

PCTEST ENGINEERING LABORATORY, INC.

DUT: Dipole 1750 MHz; Type: D1750V2; Serial: 1051

Communication System: UID 0, CW; Frequency: 1750 MHz; Duty Cycle: 1:1

Medium: 1750 Body Medium parameters used:

$f = 1750 \text{ MHz}$; $\sigma = 1.457 \text{ S/m}$; $\epsilon_r = 52.864$; $\rho = 1000 \text{ kg/m}^3$

Phantom section: Flat Section; Space: 1.0 cm

Test Date: 06-04-2014; Ambient Temp: 24.0°C; Tissue Temp: 22.8°C

Probe: ES3DV3 - SN3333; ConvF(4.95, 4.95, 4.95); Calibrated: 11/22/2013;

Sensor-Surface: 4mm (Mechanical Surface Detection)

Electronics: DAE4 Sn1408; Calibrated: 11/19/2013

Phantom: ELI v5.0; Type: QDOVA001BB; Serial: 1229

Measurement SW: DASY52, Version 52.8 (7); SEMCAD X Version 14.6.10 (7331)

1750 MHz System Verification

Area Scan (7x9x1): Measurement grid: dx=15mm, dy=15mm

Zoom Scan (5x5x7)/Cube 0: Measurement grid: dx=8mm, dy=8mm, dz=5mm

Input Power = 20 dBm (100 mW)

Peak SAR (extrapolated) = 6.80 W/kg

SAR(1 g) = 3.84 W/kg

Deviation = 2.67 %

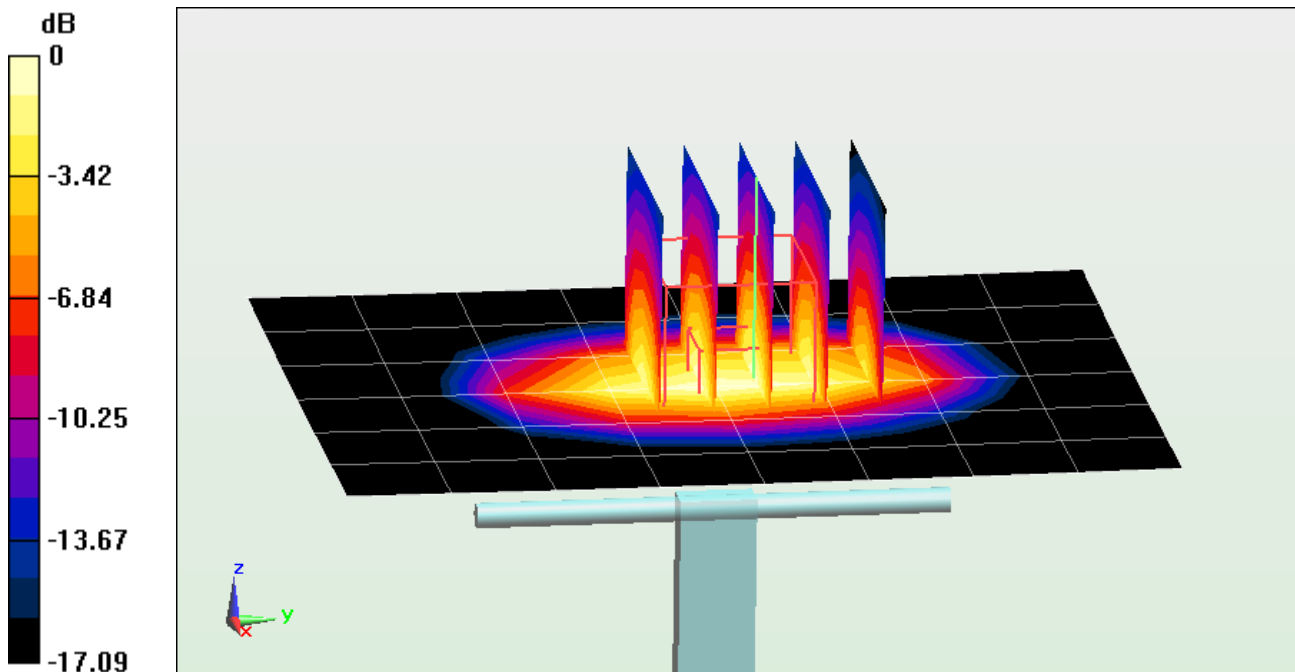

0 dB = 4.22 W/kg = 6.25 dBW/kg

PCTEST ENGINEERING LABORATORY, INC.

DUT: Dipole 2450 MHz; Type: D2450V2; Serial: 719

Communication System: UID 0, CW; Frequency: 2450 MHz; Duty Cycle: 1:1

Medium: 2450 Body Medium parameters used:

$f = 2450 \text{ MHz}$; $\sigma = 1.952 \text{ S/m}$; $\epsilon_r = 51.042$; $\rho = 1000 \text{ kg/m}^3$

Phantom section: Flat Section; Space: 1.0 cm

Test Date: 06-02-2014; Ambient Temp: 24.5°C; Tissue Temp: 23.0°C

Probe: ES3DV3 - SN3258; ConvF(4.14, 4.14, 4.14); Calibrated: 2/25/2014;

Sensor-Surface: 3mm (Mechanical Surface Detection)

Electronics: DAE4 Sn665; Calibrated: 2/26/2014

Phantom: ELI v5.0; Type: QDOVA002AA; Serial: TP-1158

Measurement SW: DASY52, Version 52.8 (7); SEMCAD X Version 14.6.10 (7331)

2450 MHz System Verification

Area Scan (8x9x1): Measurement grid: dx=12mm, dy=12mm

Zoom Scan (7x7x7)/Cube 0: Measurement grid: dx=5mm, dy=5mm, dz=5mm

Input Power = 20 dBm (100 mW)

Peak SAR (extrapolated) = 10.4 W/kg

SAR(1 g) = 5.05 W/kg

Deviation = -2.32 %

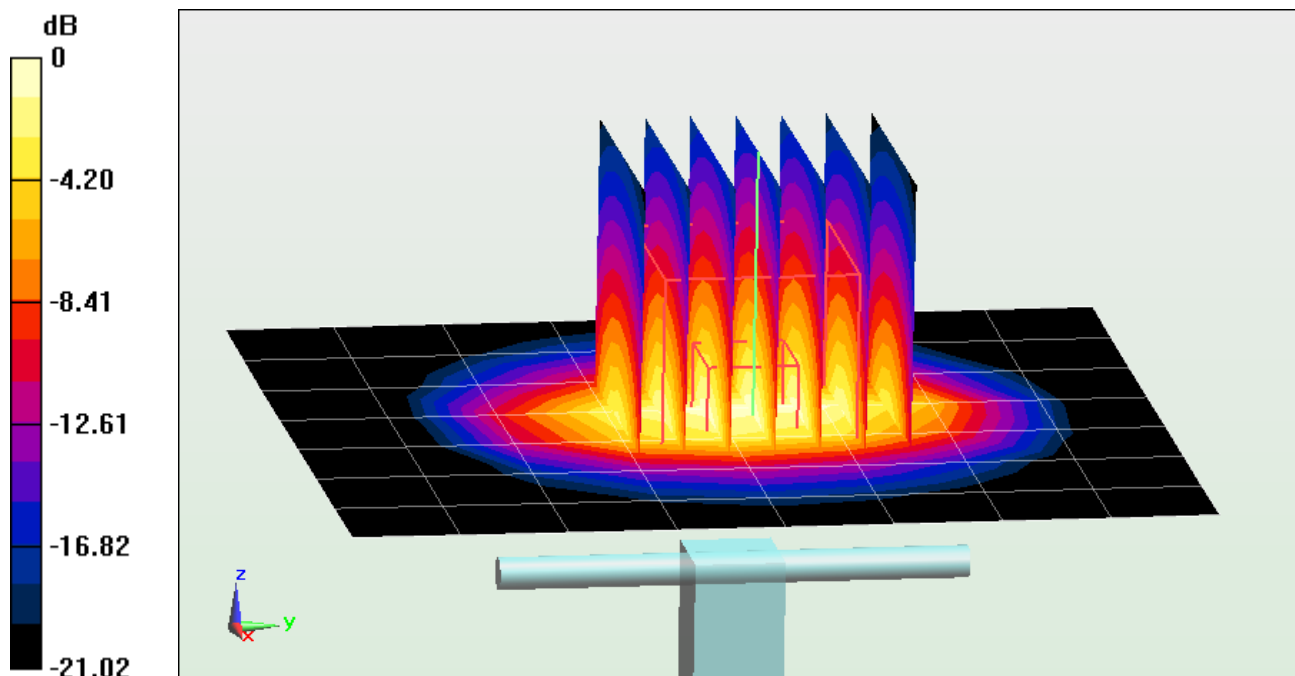

0 dB = 6.67 W/kg = 8.24 dBW/kg

PCTEST ENGINEERING LABORATORY, INC.

DUT: Dipole 5200 MHz; Type: D5GHzV2; Serial: 1007

Communication System: UID 0, CW; Frequency: 5200 MHz; Duty Cycle: 1:1

Medium: 5 GHz Body Medium parameters used:

$f = 5200 \text{ MHz}$; $\sigma = 5.243 \text{ S/m}$; $\epsilon_r = 47.101$; $\rho = 1000 \text{ kg/m}^3$

Phantom section: Flat Section; Space: 1.0 cm

Test Date: 06-02-2014; Ambient Temp: 24. $\bar{\text{C}}$; Tissue Temp: 24.5°C

Probe: EX3DV4 - SN3920; ConvF(4.23, 4.23, 4.23); Calibrated: 12/18/2013;

Sensor-Surface: 1.4mm (Mechanical Surface Detection)

Electronics: DAE4 Sn649; Calibrated: 12/12/2013

Phantom: SAM Sub; Type: SAM 4.0; Serial: TP-1357

Measurement SW: DASY4, Version 4.7 (80); SEMCAD X Version 14.6.10 (7331)

5200 MHz System Verification

Area Scan (7x9x1): Measurement grid: dx=10mm, dy=10mm

Zoom Scan (9x9x7)/Cube 0: Measurement grid: dx=4mm, dy=4mm, dz=1.4mm, Graded Ratio=1.4

Input Power = 20 dBm (100 mW)

Peak SAR (extrapolated) = 32.8 W/kg

SAR(1 g) = 7.28 W/kg

Deviation = 0.28 %

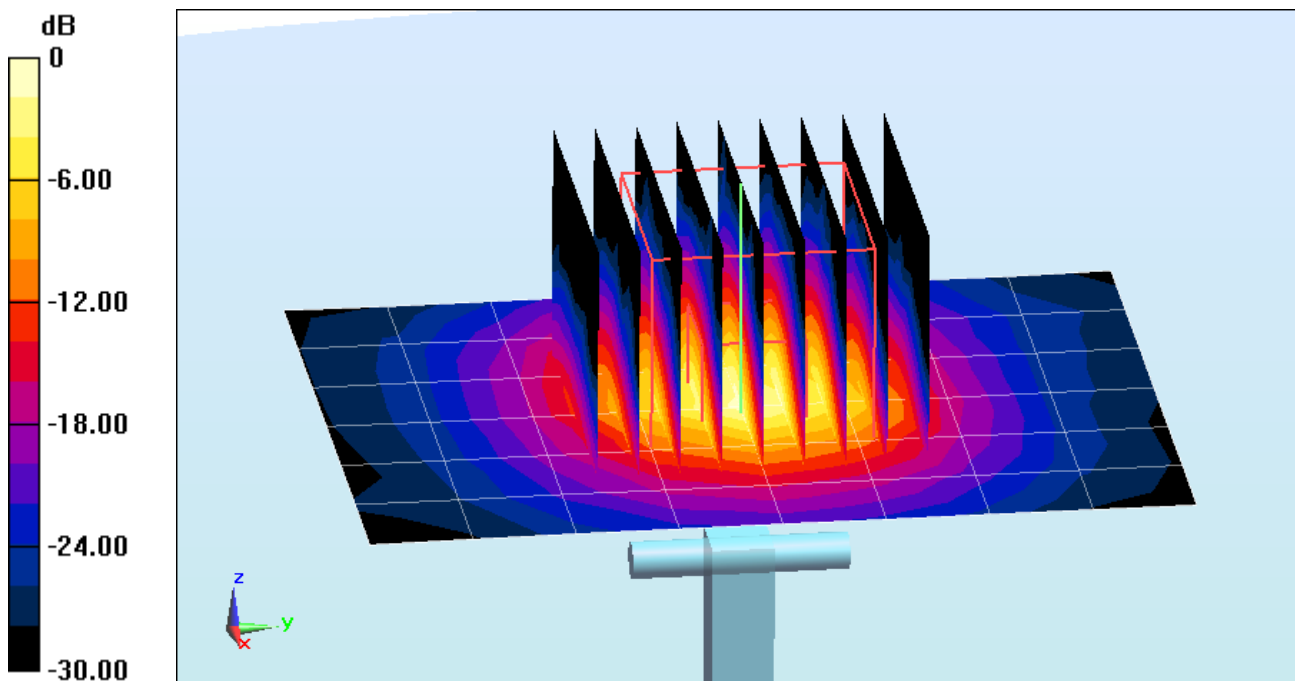

0 dB = 18.2 W/kg = 12.60 dBW/kg

PCTEST ENGINEERING LABORATORY, INC.

DUT: Dipole 5300 MHz; Type: D5GHzV2; Serial: 1007

Communication System: UID 0, CW; Frequency: 5300 MHz; Duty Cycle: 1:1

Medium: 5 GHz Body Medium parameters used:

$f = 5300 \text{ MHz}$; $\sigma = 5.376 \text{ S/m}$; $\epsilon_r = 47.023$; $\rho = 1000 \text{ kg/m}^3$

Phantom section: Flat Section; Space: 1.0 cm

Test Date: 06-02-2014; Ambient Temp: 24.4°C; Tissue Temp: 24.5°C

Probe: EX3DV4 - SN3920; ConvF(4.11, 4.11, 4.11); Calibrated: 12/18/2013;

Sensor-Surface: 1.4mm (Mechanical Surface Detection)

Electronics: DAE4 Sn649; Calibrated: 12/12/2013

Phantom: SAM Sub; Type: SAM 4.0; Serial: TP-1357

Measurement SW: DASY4, Version 4.7 (80); SEMCAD X Version 14.6.10 (7331)

5300 MHz System Verification

Area Scan (7x9x1): Measurement grid: dx=10mm, dy=10mm

Zoom Scan (9x9x7)/Cube 0: Measurement grid: dx=4mm, dy=4mm, dz=1.4mm; Graded Ratio=1.4

Input Power = 20 dBm (100 mW)

Peak SAR (extrapolated) = 33.2 W/kg

SAR(1 g) = 7.54 W/kg

Deviation = 0.94 %

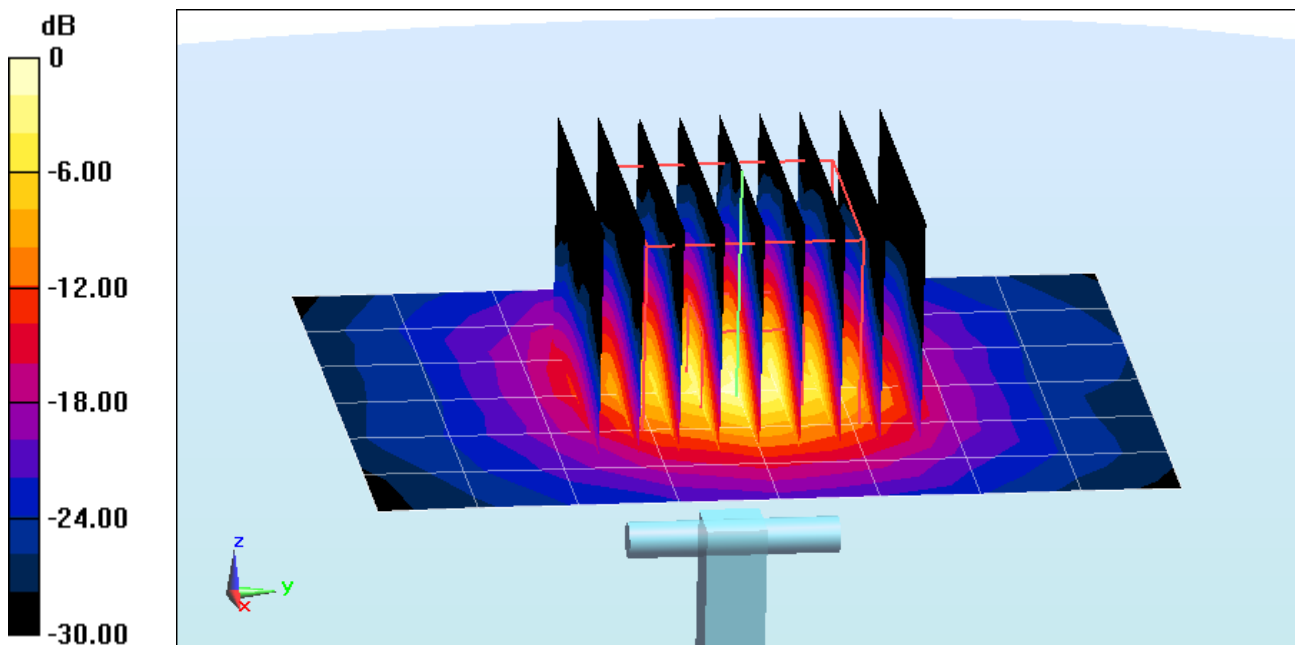

0 dB = 19.2 W/kg = 12.83 dBW/kg

PCTEST ENGINEERING LABORATORY, INC.

DUT: Dipole 5500 MHz; Type: D5GHzV2; Serial: 1007

Communication System: UID 0, CW; Frequency: 5500 MHz; Duty Cycle: 1:1

Medium: 5 GHz Body Medium parameters used:

$f = 5500 \text{ MHz}$; $\sigma = 5.644 \text{ S/m}$; $\epsilon_r = 46.819$; $\rho = 1000 \text{ kg/m}^3$

Phantom section: Flat Section; Space: 1.0 cm

Test Date: 06-02-2014; Ambient Temp: 24.5°C; Tissue Temp: 24.5°C

Probe: EX3DV4 - SN3920; ConvF(3.8, 3.8, 3.8); Calibrated: 12/18/2013;

Sensor-Surface: 1.4mm (Mechanical Surface Detection)

Electronics: DAE4 Sn649; Calibrated: 12/12/2013

Phantom: SAM Sub; Type: SAM 4.0; Serial: TP-1357

Measurement SW: DASY4, Version 4.7 (80); SEMCAD X Version 14.6.10 (7331)

5500 MHz System Verification

Area Scan (7x9x1): Measurement grid: dx=10mm, dy=10mm

Zoom Scan (9x9x7)/Cube 0: Measurement grid: dx=4mm, dy=4mm, dz=1.4mm; Graded Ratio=1.4

Input Power = 20 dBm (100 mW)

Peak SAR (extrapolated) = 36.3 W/kg

SAR(1 g) = 7.01 W/kg

Deviation = -7.64 %

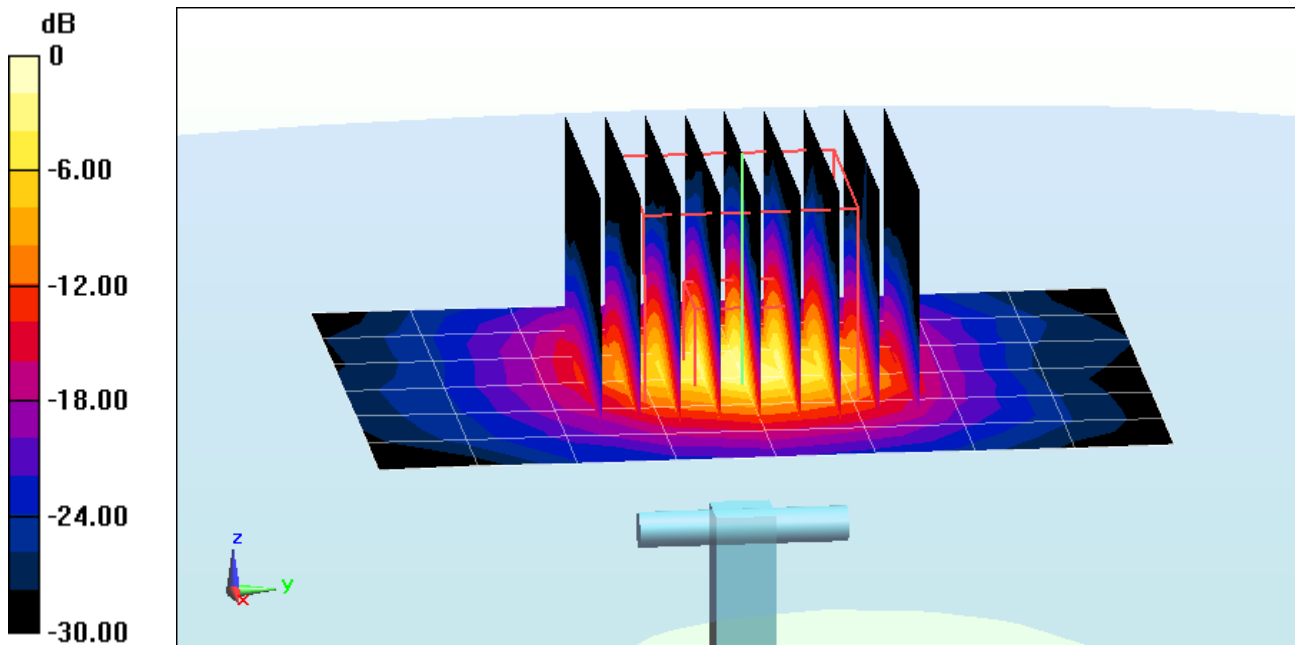

0 dB = 18.4 W/kg = 12.65 dBW/kg

PCTEST ENGINEERING LABORATORY, INC.

DUT: Dipole 5600 MHz; Type: D5GHzV2; Serial: 1007

Communication System: UID 0, CW; Frequency: 5600 MHz; Duty Cycle: 1:1

Medium: 5 GHz Body Medium parameters used:

$f = 5600 \text{ MHz}$; $\sigma = 5.772 \text{ S/m}$; $\epsilon_r = 46.705$; $\rho = 1000 \text{ kg/m}^3$

Phantom section: Flat Section; Space: 1.0 cm

Test Date: 06-02-2014; Ambient Temp: 24.5°C; Tissue Temp: 24.5°C

Probe: EX3DV4 - SN3920; ConvF(3.62, 3.62, 3.62); Calibrated: 12/18/2013;

Sensor-Surface: 1.4mm (Mechanical Surface Detection)

Electronics: DAE4 Sn649; Calibrated: 12/12/2013

Phantom: SAM Sub; Type: SAM 4.0; Serial: TP-1357

Measurement SW: DASY4, Version 4.7 (80); SEMCAD X Version 14.6.10 (7331)

5600 MHz System Verification

Area Scan (7x9x1): Measurement grid: dx=10mm, dy=10mm

Zoom Scan (9x9x7)/Cube 0: Measurement grid: dx=4mm, dy=4mm, dz=1.4mm; Graded Ratio=1.4

Input Power = 20 dBm (100 mW)

Peak SAR (extrapolated) = 37.1 W/kg

SAR(1 g) = 7.54 W/kg

Deviation = -2.46 %

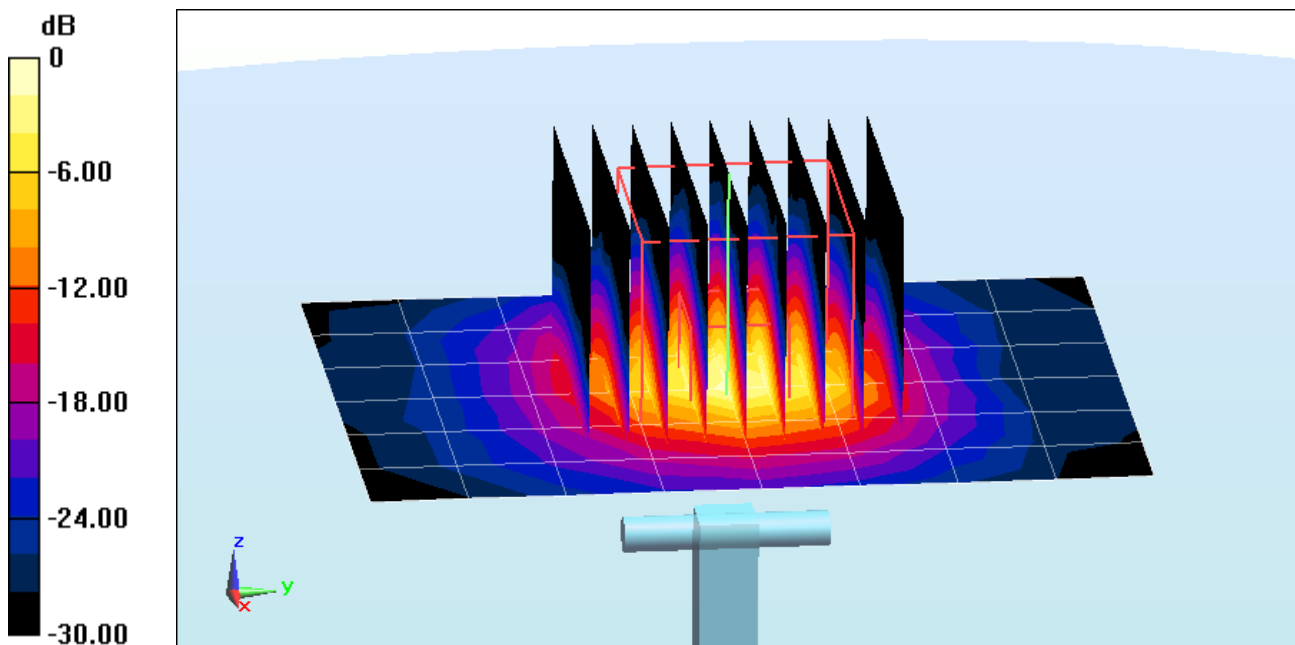

0 dB = 19.5 W/kg = 12.90 dBW/kg

PCTEST ENGINEERING LABORATORY, INC.

DUT: Dipole 5800 MHz; Type: D5GHzV2; Serial: 1007

Communication System: UID 0, CW; Frequency: 5800 MHz; Duty Cycle: 1:1

Medium: 5 GHz Body Medium parameters used:

$f = 5800 \text{ MHz}$; $\sigma = 6.004 \text{ S/m}$; $\epsilon_r = 46.303$; $\rho = 1000 \text{ kg/m}^3$

Phantom section: Flat Section; Space: 1.0 cm

Test Date: 06-02-2014; Ambient Temp: 24.5°C; Tissue Temp: 24.5°C

Probe: EX3DV4 - SN3920; ConvF(4, 4, 4); Calibrated: 12/18/2013;

Sensor-Surface: 1.4mm (Mechanical Surface Detection)

Electronics: DAE4 Sn649; Calibrated: 12/12/2013

Phantom: SAM Sub; Type: SAM 4.0; Serial: TP-1357

Measurement SW: DASY4, Version 4.7 (80); SEMCAD X Version 14.6.10 (7331)

5800 MHz System Verification

Area Scan (7x9x1): Measurement grid: dx=10mm, dy=10mm

Zoom Scan (9x9x7)/Cube 0: Measurement grid: dx=4mm, dy=4mm, dz=1.4mm; Graded Ratio=1.4

Input Power = 20 dBm (100 mW)

Peak SAR (extrapolated) = 36.5 W/kg

SAR(1 g) = 6.9 W/kg

Deviation = -5.35 %

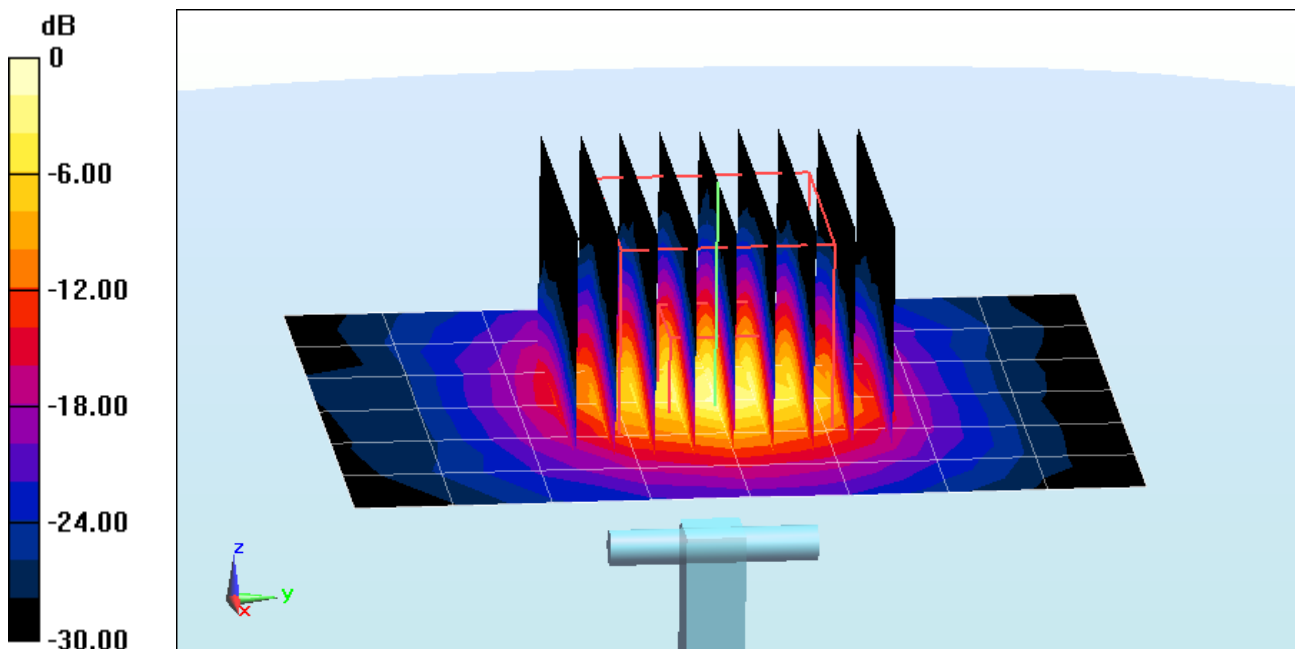

APPENDIX C: PROBE CALIBRATION



Accredited by the Swiss Accreditation Service (SAS)
The Swiss Accreditation Service is one of the signatories to the EA
Multilateral Agreement for the recognition of calibration certificates

Accreditation No.: **SCS 108**

Client **PC Test**

Certificate No: **ES3-3332_Nov13**

CALIBRATION CERTIFICATE

Object **ES3DV3 - SN:3332**

Calibration procedure(s) **QA CAL-01.v9, QA CAL-23.v5, QA CAL-25.v6
Calibration procedure for dosimetric E-field probes**

Calibration date: **November 25, 2013**

VCC
1/12/13

This calibration certificate documents the traceability to national standards, which realize the physical units of measurements (SI).
The measurements and the uncertainties with confidence probability are given on the following pages and are part of the certificate.

All calibrations have been conducted in the closed laboratory facility: environment temperature (22 ± 3)°C and humidity < 70%.

Calibration Equipment used (M&TE critical for calibration)

Primary Standards	ID	Cal Date (Certificate No.)	Scheduled Calibration
Power meter E4419B	GB41293874	04-Apr-13 (No. 217-01733)	Apr-14
Power sensor E4412A	MY41498087	04-Apr-13 (No. 217-01733)	Apr-14
Reference 3 dB Attenuator	SN: S5054 (3c)	04-Apr-13 (No. 217-01737)	Apr-14
Reference 20 dB Attenuator	SN: S5277 (20x)	04-Apr-13 (No. 217-01735)	Apr-14
Reference 30 dB Attenuator	SN: S5129 (30b)	04-Apr-13 (No. 217-01738)	Apr-14
Reference Probe ES3DV2	SN: 3013	28-Dec-12 (No. ES3-3013_Dec12)	Dec-13
DAE4	SN: 660	4-Sep-13 (No. DAE4-660_Sep13)	Sep-14
Secondary Standards	ID	Check Date (in house)	Scheduled Check
RF generator HP 8648C	US3642U01700	4-Aug-99 (in house check Apr-13)	In house check: Apr-15
Network Analyzer HP 8753E	US37390585	18-Oct-01 (in house check Oct-13)	In house check: Oct-14

	Name	Function	Signature
Calibrated by:	Leif Klysner	Laboratory Technician	
Approved by:	Katja Pokovic	Technical Manager	

Issued: November 25, 2013

This calibration certificate shall not be reproduced except in full without written approval of the laboratory.



Accredited by the Swiss Accreditation Service (SAS)

Accreditation No.: **SCS 108**

The Swiss Accreditation Service is one of the signatories to the EA Multilateral Agreement for the recognition of calibration certificates

Glossary:

TSL	tissue simulating liquid
NORM _{x,y,z}	sensitivity in free space
ConvF	sensitivity in TSL / NORM _{x,y,z}
DCP	diode compression point
CF	crest factor (1/duty_cycle) of the RF signal
A, B, C, D	modulation dependent linearization parameters
Polarization φ	φ rotation around probe axis
Polarization ϑ	ϑ rotation around an axis that is in the plane normal to probe axis (at measurement center), i.e., $\vartheta = 0$ is normal to probe axis
Connector Angle	information used in DASY system to align probe sensor X to the robot coordinate system

Calibration is Performed According to the Following Standards:

- IEEE Std 1528-2013, "IEEE Recommended Practice for Determining the Peak Spatial-Averaged Specific Absorption Rate (SAR) in the Human Head from Wireless Communications Devices: Measurement Techniques", June 2013
- IEC 62209-1, "Procedure to measure the Specific Absorption Rate (SAR) for hand-held devices used in close proximity to the ear (frequency range of 300 MHz to 3 GHz)", February 2005

Methods Applied and Interpretation of Parameters:

- NORM_{x,y,z}**: Assessed for E-field polarization $\vartheta = 0$ ($f \leq 900$ MHz in TEM-cell; $f > 1800$ MHz: R22 waveguide). NORM_{x,y,z} are only intermediate values, i.e., the uncertainties of NORM_{x,y,z} does not affect the E^2 -field uncertainty inside TSL (see below *ConvF*).
- NORM(*f*)_{x,y,z} = NORM_{x,y,z} * frequency_response** (see Frequency Response Chart). This linearization is implemented in DASY4 software versions later than 4.2. The uncertainty of the frequency response is included in the stated uncertainty of *ConvF*.
- DCP_{x,y,z}**: DCP are numerical linearization parameters assessed based on the data of power sweep with CW signal (no uncertainty required). DCP does not depend on frequency nor media.
- PAR**: PAR is the Peak to Average Ratio that is not calibrated but determined based on the signal characteristics
- A_{x,y,z}; B_{x,y,z}; C_{x,y,z}; D_{x,y,z}; VR_{x,y,z}; A, B, C, D** are numerical linearization parameters assessed based on the data of power sweep for specific modulation signal. The parameters do not depend on frequency nor media. VR is the maximum calibration range expressed in RMS voltage across the diode.
- ConvF and Boundary Effect Parameters**: Assessed in flat phantom using E-field (or Temperature Transfer Standard for $f \leq 800$ MHz) and inside waveguide using analytical field distributions based on power measurements for $f > 800$ MHz. The same setups are used for assessment of the parameters applied for boundary compensation (alpha, depth) of which typical uncertainty values are given. These parameters are used in DASY4 software to improve probe accuracy close to the boundary. The sensitivity in TSL corresponds to NORM_{x,y,z} * ConvF whereby the uncertainty corresponds to that given for ConvF. A frequency dependent ConvF is used in DASY version 4.4 and higher which allows extending the validity from ± 50 MHz to ± 100 MHz.
- Spherical isotropy (3D deviation from isotropy)**: in a field of low gradients realized using a flat phantom exposed by a patch antenna.
- Sensor Offset**: The sensor offset corresponds to the offset of virtual measurement center from the probe tip (on probe axis). No tolerance required.
- Connector Angle**: The angle is assessed using the information gained by determining the NORM_x (no uncertainty required).

Probe ES3DV3

SN:3332

Manufactured: January 24, 2012
Calibrated: November 25, 2013

Calibrated for DASY/EASY Systems
(Note: non-compatible with DASY2 system!)

DASY/EASY - Parameters of Probe: ES3DV3 - SN:3332

Basic Calibration Parameters

	Sensor X	Sensor Y	Sensor Z	Unc (k=2)
Norm ($\mu\text{V}/(\text{V}/\text{m})^2$) ^A	0.94	1.16	0.97	± 10.1 %
DCP (mV) ^B	103.5	101.0	111.0	

Modulation Calibration Parameters

UID	Communication System Name		A dB	B dB $\sqrt{\mu\text{V}}$	C	D dB	VR mV	Unc ^E (k=2)
0	CW	X	0.0	0.0	1.0	0.00	179.7	±2.5 %
		Y	0.0	0.0	1.0		147.3	
		Z	0.0	0.0	1.0		188.8	

The reported uncertainty of measurement is stated as the standard uncertainty of measurement multiplied by the coverage factor k=2, which for a normal distribution corresponds to a coverage probability of approximately 95%.

^A The uncertainties of NormX,Y,Z do not affect the E²-field uncertainty inside TSL (see Pages 5 and 6).

^B Numerical linearization parameter: uncertainty not required.

^E Uncertainty is determined using the max. deviation from linear response applying rectangular distribution and is expressed for the square of the field value.

DASY/EASY - Parameters of Probe: ES3DV3 - SN:3332

Calibration Parameter Determined in Head Tissue Simulating Media

f (MHz) ^C	Relative Permittivity ^F	Conductivity (S/m) ^F	ConvF X	ConvF Y	ConvF Z	Alpha ^G	Depth ^G (mm)	Unct. (k=2)
750	41.9	0.89	6.46	6.46	6.46	0.52	1.42	± 12.0 %
850	41.5	0.92	6.29	6.29	6.29	0.78	1.17	± 12.0 %
1750	40.1	1.37	5.27	5.27	5.27	0.80	1.10	± 12.0 %
1900	40.0	1.40	5.06	5.06	5.06	0.80	1.18	± 12.0 %
2450	39.2	1.80	4.50	4.50	4.50	0.80	1.19	± 12.0 %
2600	39.0	1.96	4.38	4.38	4.38	0.76	1.31	± 12.0 %

^C Frequency validity of ± 100 MHz only applies for DASY v4.4 and higher (see Page 2), else it is restricted to ± 50 MHz. The uncertainty is the RSS of the ConvF uncertainty at calibration frequency and the uncertainty for the indicated frequency band.

^F At frequencies below 3 GHz, the validity of tissue parameters (ϵ and σ) can be relaxed to ± 10% if liquid compensation formula is applied to measured SAR values. At frequencies above 3 GHz, the validity of tissue parameters (ϵ and σ) is restricted to ± 5%. The uncertainty is the RSS of the ConvF uncertainty for indicated target tissue parameters.

^G Alpha/Depth are determined during calibration. SPEAG warrants that the remaining deviation due to the boundary effect after compensation is always less than ± 1% for frequencies below 3 GHz and below ± 2% for frequencies between 3-6 GHz at any distance larger than half the probe tip diameter from the boundary.

DASY/EASY - Parameters of Probe: ES3DV3 - SN:3332

Calibration Parameter Determined in Body Tissue Simulating Media

f (MHz) ^C	Relative Permittivity ^F	Conductivity (S/m) ^F	ConvF X	ConvF Y	ConvF Z	Alpha ^G	Depth ^G (mm)	Unct. (k=2)
750	55.5	0.96	6.21	6.21	6.21	0.80	1.19	± 12.0 %
850	55.2	0.99	6.08	6.08	6.08	0.51	1.48	± 12.0 %
1750	53.4	1.49	4.93	4.93	4.93	0.42	1.72	± 12.0 %
1900	53.3	1.52	4.70	4.70	4.70	0.48	1.59	± 12.0 %
2450	52.7	1.95	4.24	4.24	4.24	0.80	1.01	± 12.0 %
2600	52.5	2.16	4.07	4.07	4.07	0.80	0.50	± 12.0 %

^C Frequency validity of ± 100 MHz only applies for DASY v4.4 and higher (see Page 2), else it is restricted to ± 50 MHz. The uncertainty is the RSS of the ConvF uncertainty at calibration frequency and the uncertainty for the indicated frequency band.

^F At frequencies below 3 GHz, the validity of tissue parameters (ϵ and σ) can be relaxed to ± 10% if liquid compensation formula is applied to measured SAR values. At frequencies above 3 GHz, the validity of tissue parameters (ϵ and σ) is restricted to ± 5%. The uncertainty is the RSS of the ConvF uncertainty for indicated target tissue parameters.

^G Alpha/Depth are determined during calibration. SPEAG warrants that the remaining deviation due to the boundary effect after compensation is always less than ± 1% for frequencies below 3 GHz and below ± 2% for frequencies between 3-6 GHz at any distance larger than half the probe tip diameter from the boundary.

Frequency Response of E-Field (TEM-Cell:ifi110 EXX, Waveguide: R22)

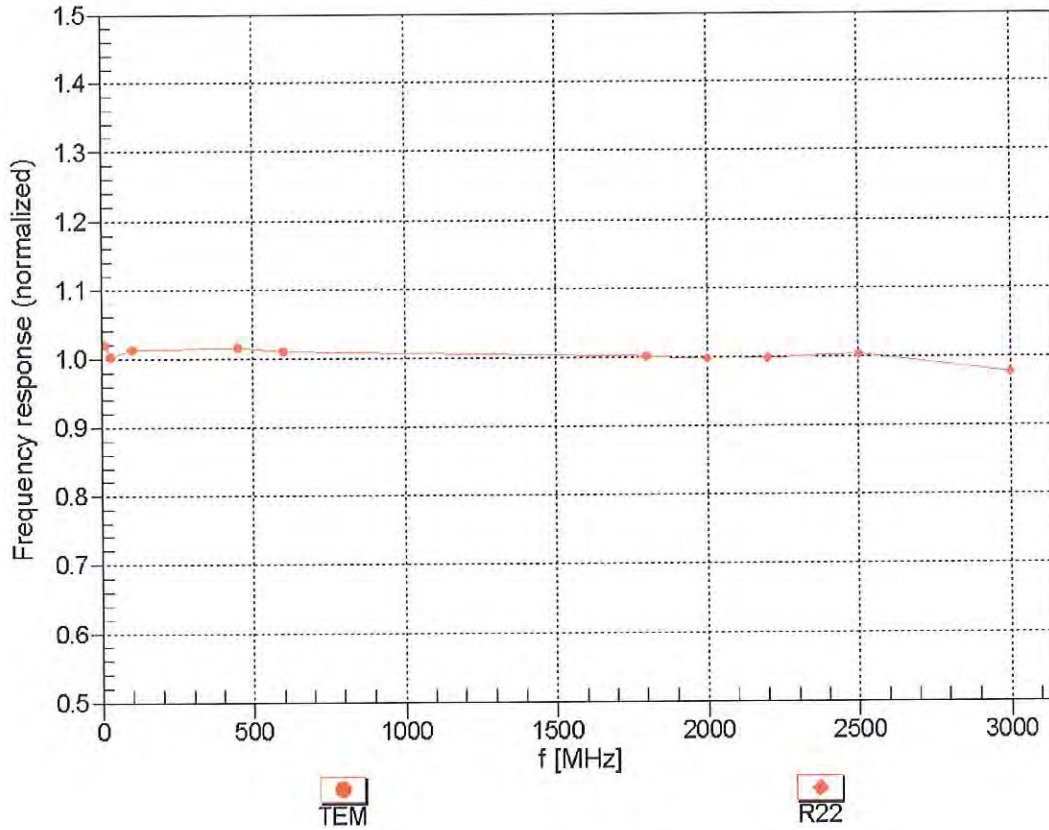

Uncertainty of Frequency Response of E-field: $\pm 6.3\%$ (k=2)

Receiving Pattern (ϕ), $\vartheta = 0^\circ$

f=600 MHz,TEM

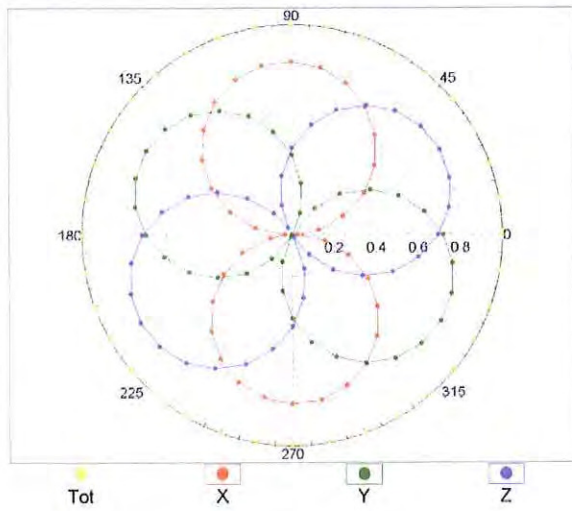

f=1800 MHz,R22

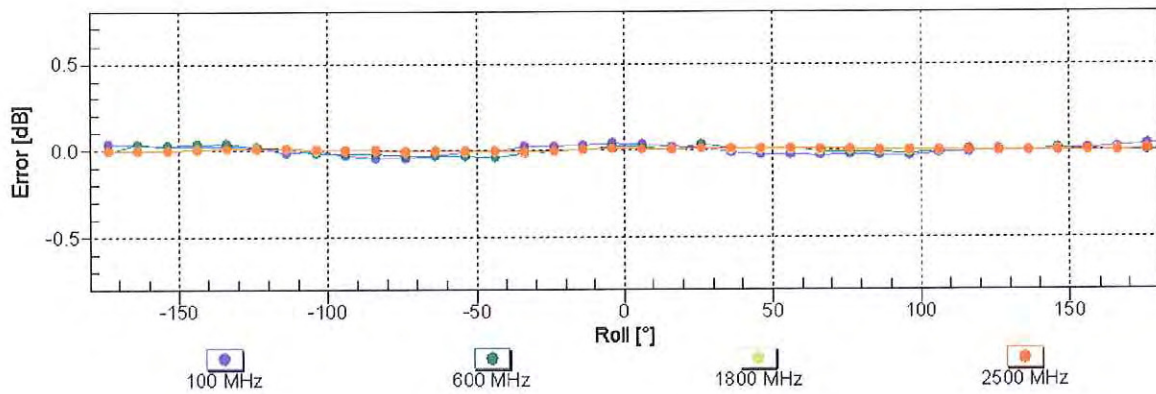
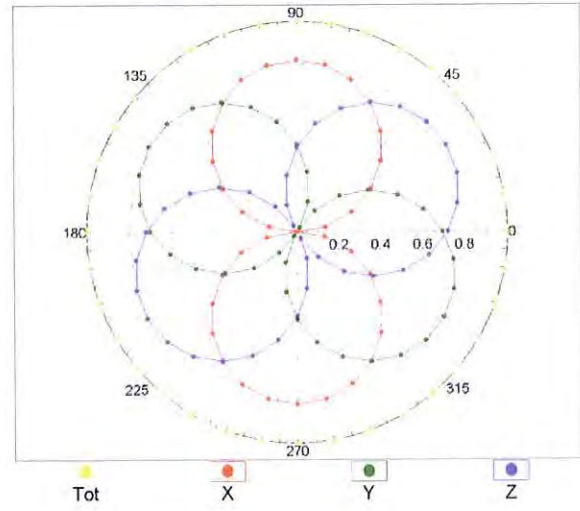

Uncertainty of Axial Isotropy Assessment: $\pm 0.5\%$ ($k=2$)

Dynamic Range $f(\text{SAR}_{\text{head}})$ (TEM cell , $f = 900 \text{ MHz}$)

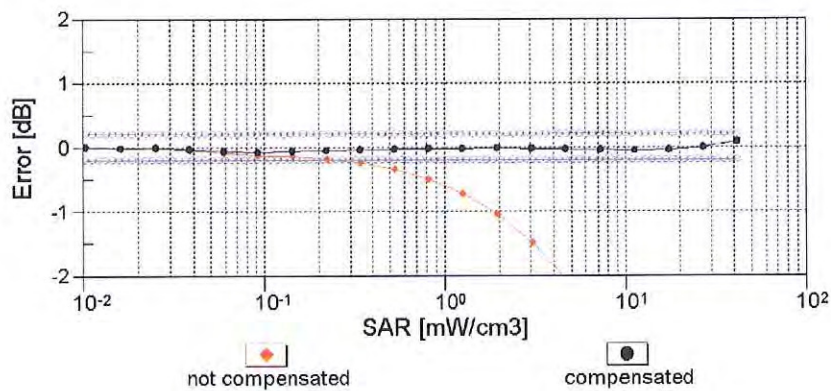
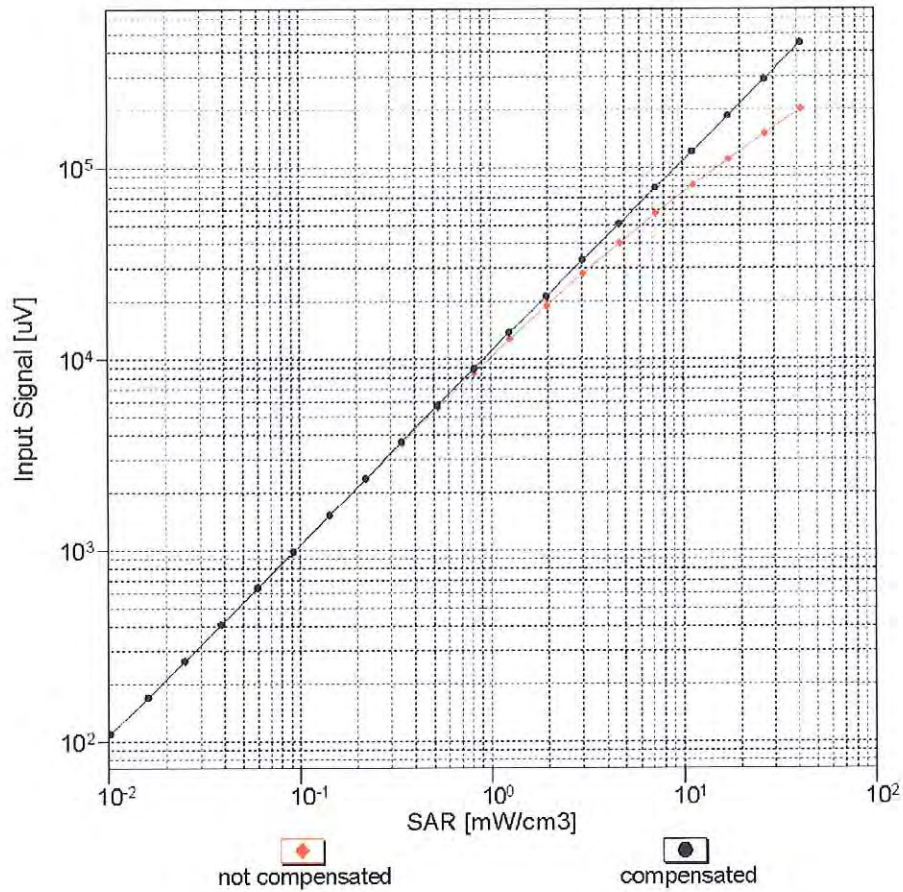

Uncertainty of Linearity Assessment: $\pm 0.6\%$ ($k=2$)

Conversion Factor Assessment

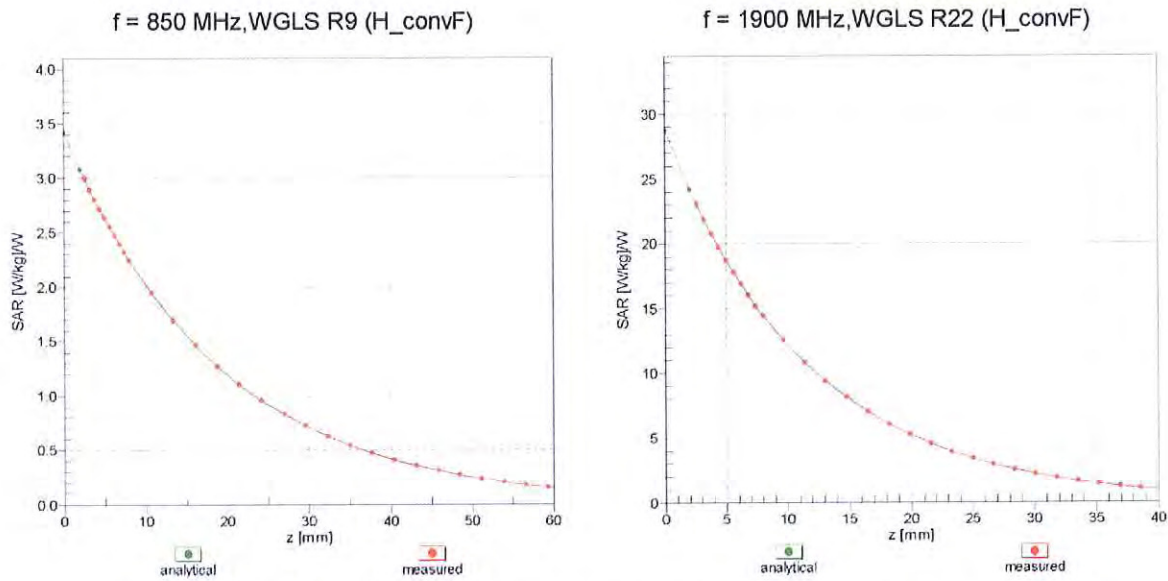

Deviation from Isotropy in Liquid Error (ϕ, ϑ), f = 900 MHz

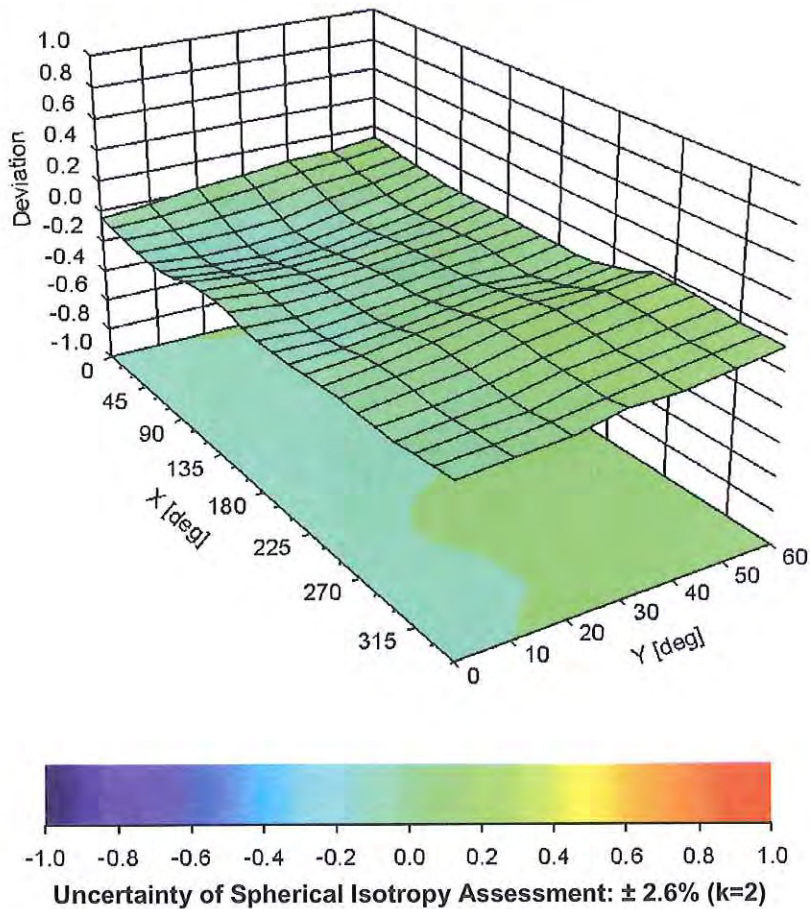

DASY/EASY - Parameters of Probe: ES3DV3 - SN:3332**Other Probe Parameters**

Sensor Arrangement	Triangular
Connector Angle (°)	-3.9
Mechanical Surface Detection Mode	enabled
Optical Surface Detection Mode	disabled
Probe Overall Length	337 mm
Probe Body Diameter	10 mm
Tip Length	10 mm
Tip Diameter	4 mm
Probe Tip to Sensor X Calibration Point	2 mm
Probe Tip to Sensor Y Calibration Point	2 mm
Probe Tip to Sensor Z Calibration Point	2 mm
Recommended Measurement Distance from Surface	3 mm



Accredited by the Swiss Accreditation Service (SAS)
The Swiss Accreditation Service is one of the signatories to the EA
Multilateral Agreement for the recognition of calibration certificates

Accreditation No.: **SCS 108**

Client **PC Test**

Certificate No: **ES3-3333_Nov13**

CALIBRATION CERTIFICATE

Object **ES3DV3 - SN:3333**

Calibration procedure(s) **QA CAL 01.15, QA CAL 23.15, QA CAL 25.15
Calibration procedure for dielectric E-field probes**

Calibration date: **November 22, 2013**

*KOK
11/21/14*

This calibration certificate documents the traceability to national standards, which realize the physical units of measurements (SI).
The measurements and the uncertainties with confidence probability are given on the following pages and are part of the certificate.

All calibrations have been conducted in the closed laboratory facility: environment temperature (22 ± 3)°C and humidity < 70%.

Calibration Equipment used (M&TE critical for calibration)

Primary Standards	ID	Cal Date (Certificate No.)	Scheduled Calibration
Power meter E4419B	GB41293874	04-Apr-13 (No. 217-01733)	Apr-14
Power sensor E4412A	MY41498087	04-Apr-13 (No. 217-01733)	Apr-14
Reference 3 dB Attenuator	SN: S5054 (3c)	04-Apr-13 (No. 217-01737)	Apr-14
Reference 20 dB Attenuator	SN: S5277 (20x)	04-Apr-13 (No. 217-01735)	Apr-14
Reference 30 dB Attenuator	SN: S5129 (30b)	04-Apr-13 (No. 217-01738)	Apr-14
Reference Probe ES3DV2	SN: 3013	28-Dec-12 (No. ES3-3013_Dec12)	Dec-13
DAE4	SN: 660	4-Sep-13 (No. DAE4-660_Sep13)	Sep-14
Secondary Standards	ID	Check Date (in house)	Scheduled Check
RF generator HP 8648C	US3642U01700	4-Aug-99 (in house check Apr-13)	In house check: Apr-15
Network Analyzer HP 8753E	US37390585	18-Oct-01 (in house check Oct-13)	In house check: Oct-14

	Name	Function	Signature
Calibrated by:	Jeton Kastrati	Laboratory Technician	<i>[Signature]</i>
Approved by:	Katja Pokovic	Technical Manager	<i>[Signature]</i>

Issued: November 25, 2013

This calibration certificate shell not be reproduced except in full without written approval of the laboratory.



Accredited by the Swiss Accreditation Service (SAS)

Accreditation No.: **SCS 108**

The Swiss Accreditation Service is one of the signatories to the EA
Multilateral Agreement for the recognition of calibration certificates

Glossary:

TSL	tissue simulating liquid
NORM _{x,y,z}	sensitivity in free space
ConvF	sensitivity in TSL / NORM _{x,y,z}
DCP	diode compression point
CF	crest factor (1/duty_cycle) of the RF signal
A, B, C, D	modulation dependent linearization parameters
Polarization ϕ	ϕ rotation around probe axis
Polarization ϑ	ϑ rotation around an axis that is in the plane normal to probe axis (at measurement center), i.e., $\vartheta = 0$ is normal to probe axis
Connector Angle	information used in DASY system to align probe sensor X to the robot coordinate system

Calibration is Performed According to the Following Standards:

- IEEE Std 1528-2013, "IEEE Recommended Practice for Determining the Peak Spatial-Averaged Specific Absorption Rate (SAR) in the Human Head from Wireless Communications Devices: Measurement Techniques", June 2013
- IEC 62209-1, "Procedure to measure the Specific Absorption Rate (SAR) for hand-held devices used in close proximity to the ear (frequency range of 300 MHz to 3 GHz)", February 2005

Methods Applied and Interpretation of Parameters:

- NORM_{x,y,z}**: Assessed for E-field polarization $\vartheta = 0$ ($f \leq 900$ MHz in TEM-cell; $f > 1800$ MHz: R22 waveguide). NORM_{x,y,z} are only intermediate values, i.e., the uncertainties of NORM_{x,y,z} does not affect the E²-field uncertainty inside TSL (see below ConvF).
- NORM(f)_{x,y,z}** = NORM_{x,y,z} * frequency_response (see Frequency Response Chart). This linearization is implemented in DASY4 software versions later than 4.2. The uncertainty of the frequency response is included in the stated uncertainty of ConvF.
- DCP_{x,y,z}**: DCP are numerical linearization parameters assessed based on the data of power sweep with CW signal (no uncertainty required). DCP does not depend on frequency nor media.
- PAR**: PAR is the Peak to Average Ratio that is not calibrated but determined based on the signal characteristics
- A_{x,y,z}; B_{x,y,z}; C_{x,y,z}; D_{x,y,z}; VR_{x,y,z}; A, B, C, D** are numerical linearization parameters assessed based on the data of power sweep for specific modulation signal. The parameters do not depend on frequency nor media. VR is the maximum calibration range expressed in RMS voltage across the diode.
- ConvF and Boundary Effect Parameters**: Assessed in flat phantom using E-field (or Temperature Transfer Standard for $f \leq 800$ MHz) and inside waveguide using analytical field distributions based on power measurements for $f > 800$ MHz. The same setups are used for assessment of the parameters applied for boundary compensation (alpha, depth) of which typical uncertainty values are given. These parameters are used in DASY4 software to improve probe accuracy close to the boundary. The sensitivity in TSL corresponds to NORM_{x,y,z} * ConvF whereby the uncertainty corresponds to that given for ConvF. A frequency dependent ConvF is used in DASY version 4.4 and higher which allows extending the validity from ± 50 MHz to ± 100 MHz.
- Spherical isotropy (3D deviation from isotropy)**: in a field of low gradients realized using a flat phantom exposed by a patch antenna.
- Sensor Offset**: The sensor offset corresponds to the offset of virtual measurement center from the probe tip (on probe axis). No tolerance required.
- Connector Angle**: The angle is assessed using the information gained by determining the NORM_x (no uncertainty required).

Probe ES3DV3

SN:3333

Manufactured: January 24, 2012
Calibrated: November 22, 2013

Calibrated for DASY/EASY Systems
(Note: non-compatible with DASY2 system!)

DASY/EASY - Parameters of Probe: ES3DV3 - SN:3333

Basic Calibration Parameters

	Sensor X	Sensor Y	Sensor Z	Unc (k=2)
Norm ($\mu\text{V}/(\text{V}/\text{m})^2$) ^A	1.08	0.90	0.88	$\pm 10.1 \%$
DCP (mV) ^B	104.9	103.3	101.7	

Modulation Calibration Parameters

UID	Communication System Name		A dB	B dB $\sqrt{\mu\text{V}}$	C	D dB	VR mV	Unc ^E (k=2)
0	CW	X	0.0	0.0	1.0	0.00	140.9	$\pm 2.2 \%$
		Y	0.0	0.0	1.0		132.0	
		Z	0.0	0.0	1.0		170.3	

The reported uncertainty of measurement is stated as the standard uncertainty of measurement multiplied by the coverage factor $k=2$, which for a normal distribution corresponds to a coverage probability of approximately 95%.

^A The uncertainties of NormX,Y,Z do not affect the E^2 -field uncertainty inside TSL (see Pages 5 and 6).

^B Numerical linearization parameter: uncertainty not required.

^E Uncertainty is determined using the max. deviation from linear response applying rectangular distribution and is expressed for the square of the field value.

DASY/EASY - Parameters of Probe: ES3DV3 - SN:3333

Calibration Parameter Determined in Head Tissue Simulating Media

f (MHz) ^C	Relative Permittivity ^F	Conductivity (S/m) ^F	ConvF X	ConvF Y	ConvF Z	Alpha ^G	Depth ^G (mm)	Unct. (k=2)
750	41.9	0.89	6.56	6.56	6.56	0.44	1.54	± 12.0 %
850	41.5	0.92	6.30	6.30	6.30	0.46	1.48	± 12.0 %
1750	40.1	1.37	5.23	5.23	5.23	0.77	1.17	± 12.0 %
1900	40.0	1.40	5.05	5.05	5.05	0.80	1.19	± 12.0 %
2450	39.2	1.80	4.42	4.42	4.42	0.74	1.31	± 12.0 %
2600	39.0	1.96	4.28	4.28	4.28	0.80	1.30	± 12.0 %

^C Frequency validity of ± 100 MHz only applies for DASY v4.4 and higher (see Page 2), else it is restricted to ± 50 MHz. The uncertainty is the RSS of the ConvF uncertainty at calibration frequency and the uncertainty for the indicated frequency band.

^F At frequencies below 3 GHz, the validity of tissue parameters (ϵ and σ) can be relaxed to ± 10% if liquid compensation formula is applied to measured SAR values. At frequencies above 3 GHz, the validity of tissue parameters (ϵ and σ) is restricted to ± 5%. The uncertainty is the RSS of the ConvF uncertainty for indicated target tissue parameters.

^G Alpha/Depth are determined during calibration. SPEAG warrants that the remaining deviation due to the boundary effect after compensation is always less than ± 1% for frequencies below 3 GHz and below ± 2% for frequencies between 3-6 GHz at any distance larger than half the probe tip diameter from the boundary.

DASY/EASY - Parameters of Probe: ES3DV3 - SN:3333

Calibration Parameter Determined in Body Tissue Simulating Media

f (MHz) ^C	Relative Permittivity ^F	Conductivity (S/m) ^F	ConvF X	ConvF Y	ConvF Z	Alpha ^G	Depth ^G (mm)	Unct. (k=2)
750	55.5	0.96	6.11	6.11	6.11	0.33	1.90	± 12.0 %
850	55.2	0.99	6.07	6.07	6.07	0.80	1.19	± 12.0 %
1750	53.4	1.49	4.95	4.95	4.95	0.80	1.26	± 12.0 %
1900	53.3	1.52	4.71	4.71	4.71	0.49	1.54	± 12.0 %
2450	52.7	1.95	4.22	4.22	4.22	0.80	0.95	± 12.0 %
2600	52.5	2.16	4.16	4.16	4.16	0.80	1.07	± 12.0 %

^C Frequency validity of ± 100 MHz only applies for DASY v4.4 and higher (see Page 2), else it is restricted to ± 50 MHz. The uncertainty is the RSS of the ConvF uncertainty at calibration frequency and the uncertainty for the indicated frequency band.

^F At frequencies below 3 GHz, the validity of tissue parameters (ϵ and σ) can be relaxed to ± 10% if liquid compensation formula is applied to measured SAR values. At frequencies above 3 GHz, the validity of tissue parameters (ϵ and σ) is restricted to ± 5%. The uncertainty is the RSS of the ConvF uncertainty for indicated target tissue parameters.

^G Alpha/Depth are determined during calibration. SPEAG warrants that the remaining deviation due to the boundary effect after compensation is always less than ± 1% for frequencies below 3 GHz and below ± 2% for frequencies between 3-6 GHz at any distance larger than half the probe tip diameter from the boundary.

Frequency Response of E-Field (TEM-Cell:ifi110 EXX, Waveguide: R22)

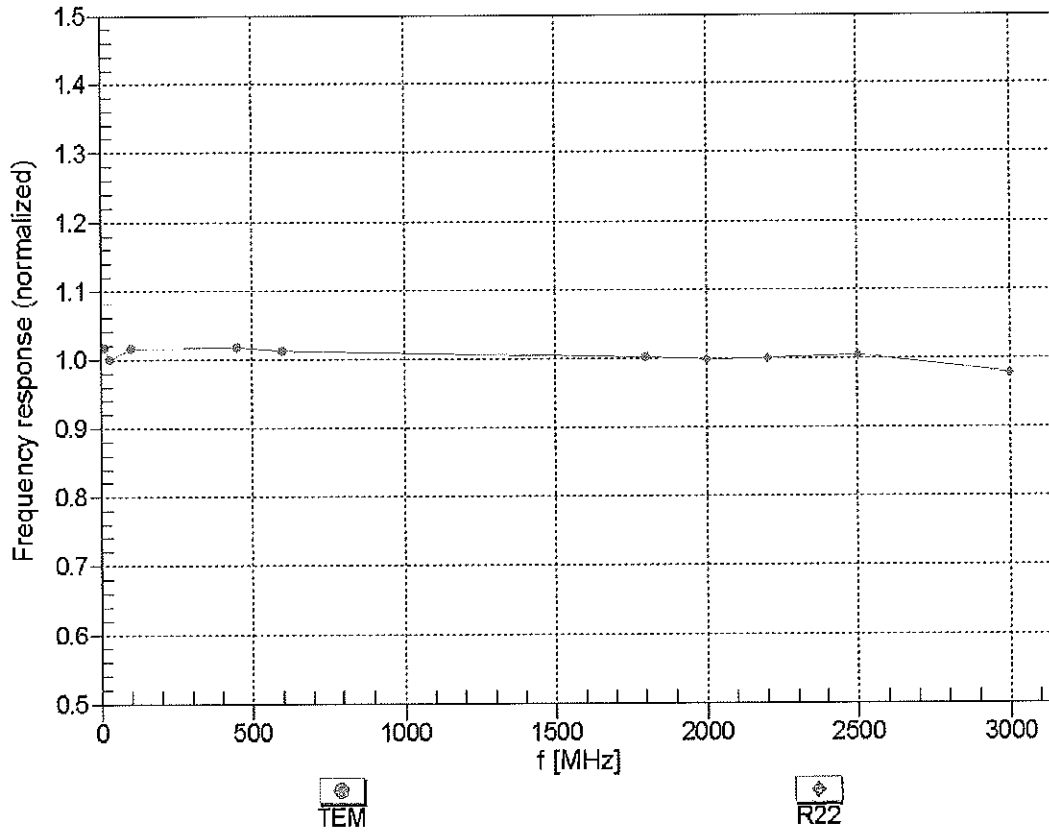

Uncertainty of Frequency Response of E-field: $\pm 6.3\%$ (k=2)

Receiving Pattern (ϕ), $\theta = 0^\circ$

f=600 MHz,TEM

f=1800 MHz,R22

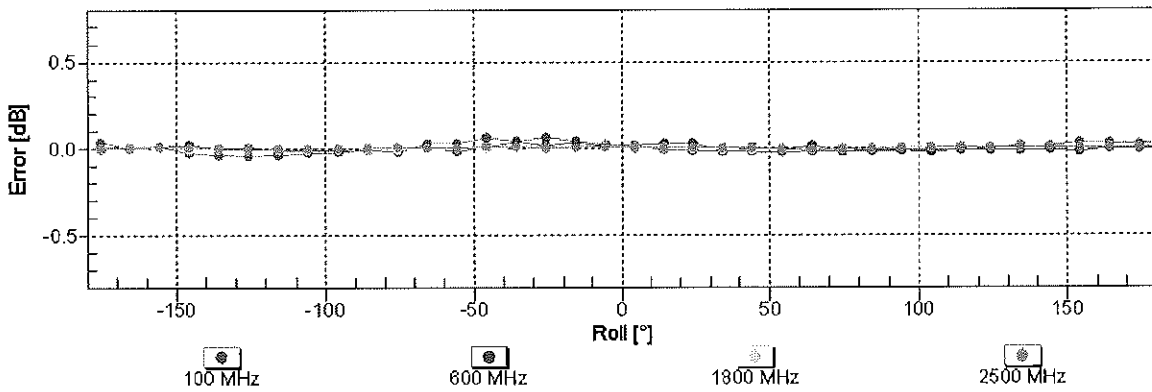
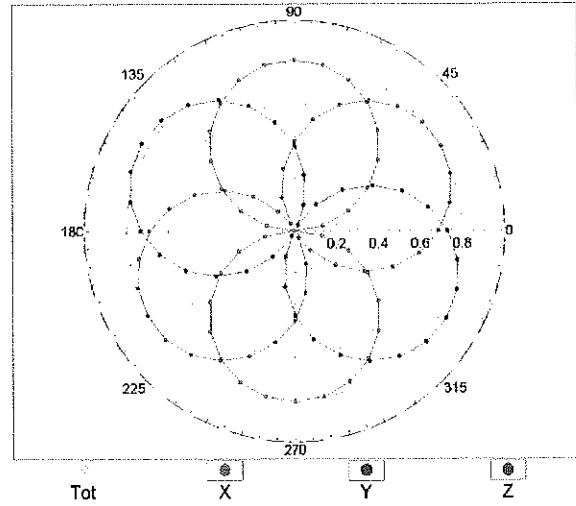
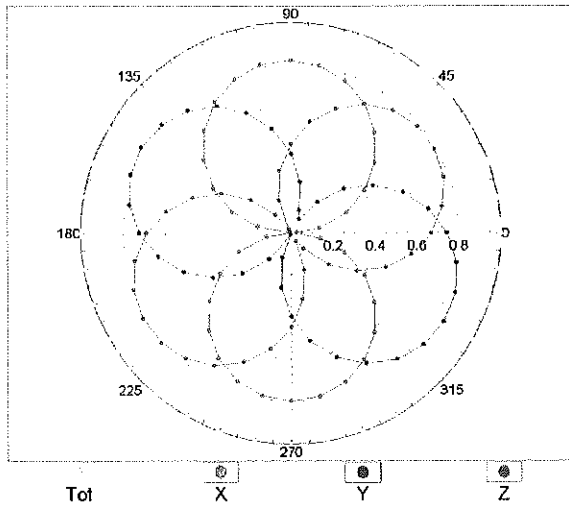

Uncertainty of Axial Isotropy Assessment: $\pm 0.5\%$ (k=2)

Dynamic Range $f(\text{SAR}_{\text{head}})$ (TEM cell , $f = 900 \text{ MHz}$)

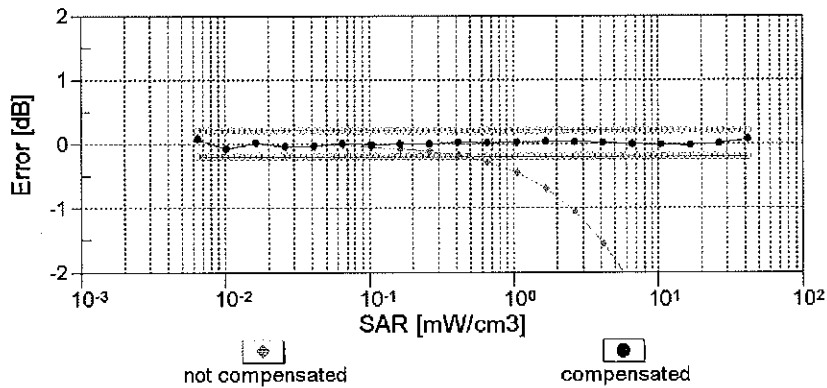
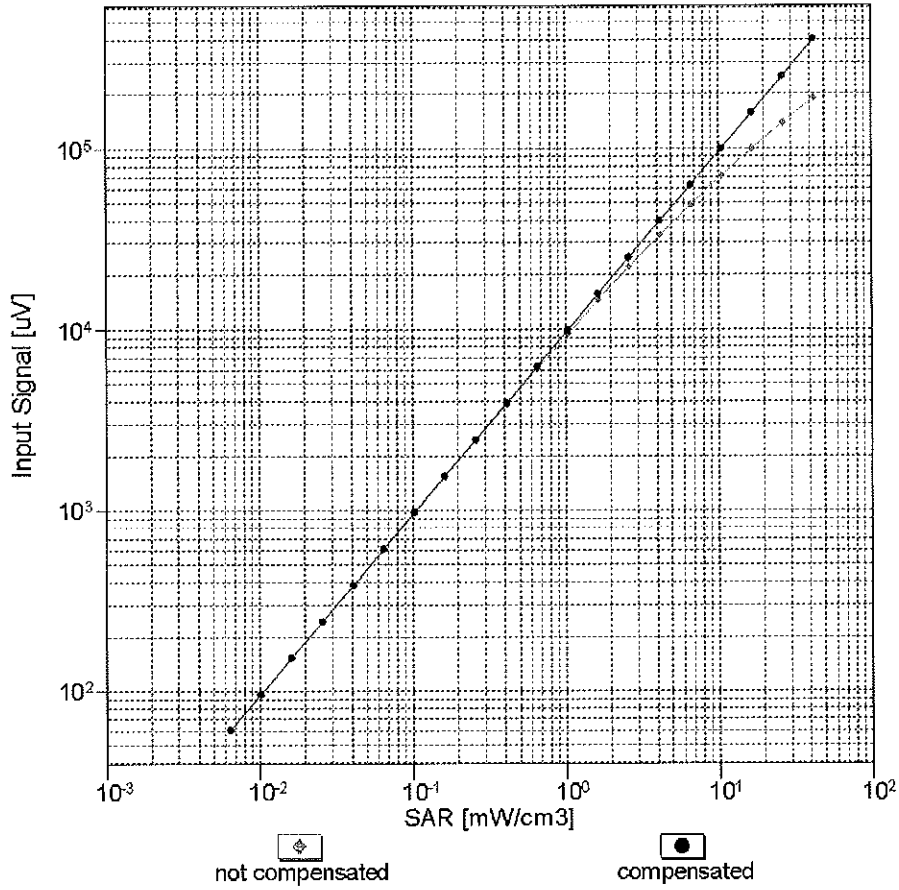

Uncertainty of Linearity Assessment: $\pm 0.6\%$ ($k=2$)

Conversion Factor Assessment

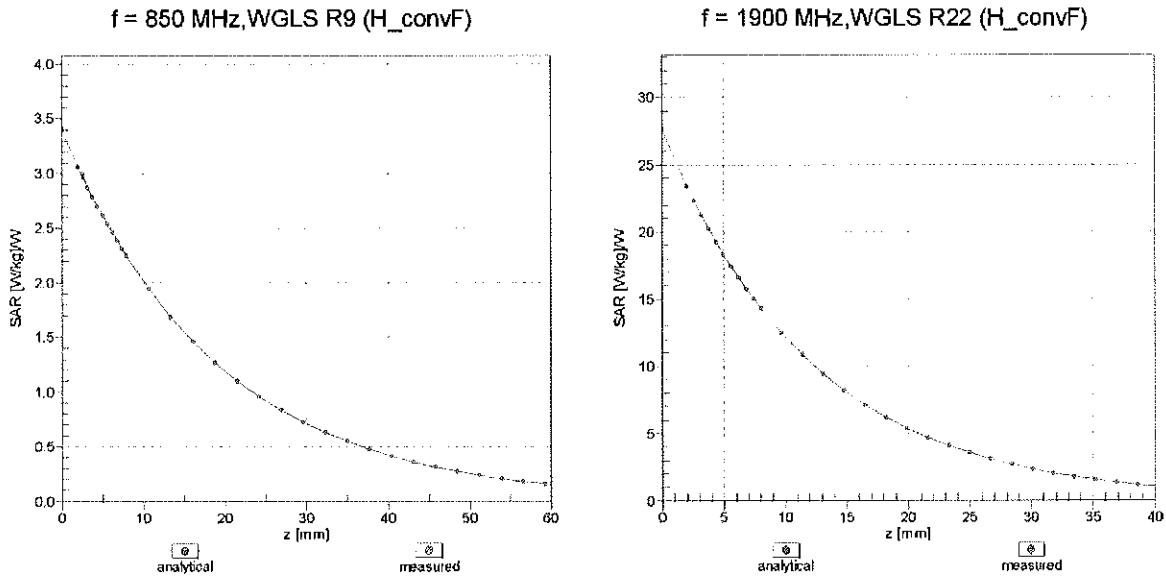

Deviation from Isotropy in Liquid Error (ϕ, θ), f = 900 MHz

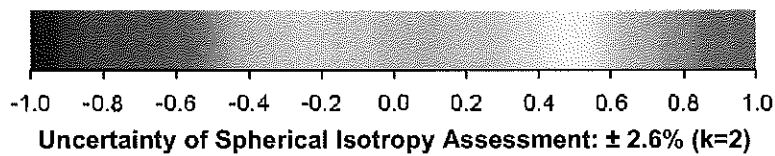
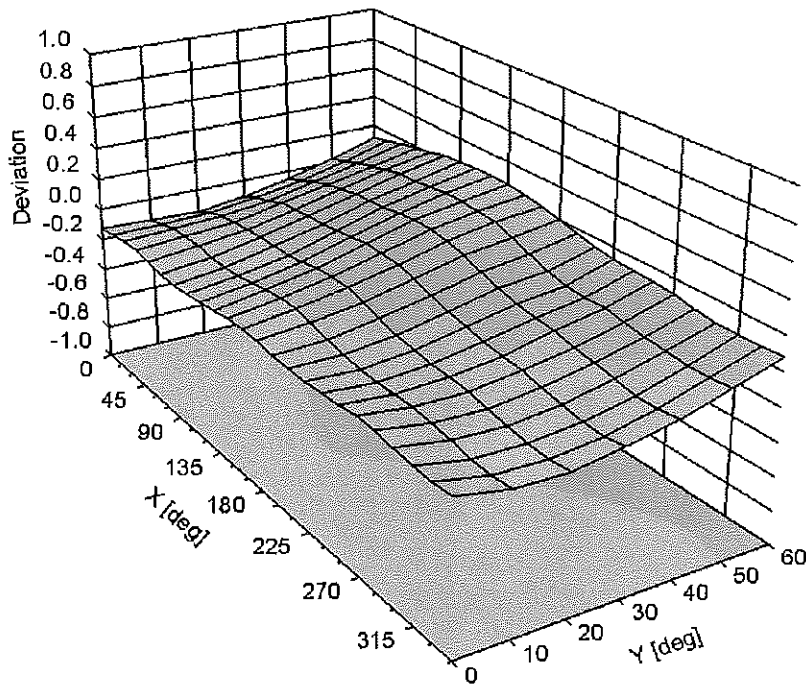

DASY/EASY - Parameters of Probe: ES3DV3 - SN:3333**Other Probe Parameters**

Sensor Arrangement	Triangular
Connector Angle (°)	-35.7
Mechanical Surface Detection Mode	enabled
Optical Surface Detection Mode	disabled
Probe Overall Length	337 mm
Probe Body Diameter	10 mm
Tip Length	10 mm
Tip Diameter	4 mm
Probe Tip to Sensor X Calibration Point	2 mm
Probe Tip to Sensor Y Calibration Point	2 mm
Probe Tip to Sensor Z Calibration Point	2 mm
Recommended Measurement Distance from Surface	3 mm



Accredited by the Swiss Accreditation Service (SAS)
 The Swiss Accreditation Service is one of the signatories to the EA
 Multilateral Agreement for the recognition of calibration certificates

Accreditation No.: **SCS 108**

Client **PC Test**

Certificate No: **D1750V2-1051_Apr14**

CALIBRATION CERTIFICATE

Object **D1750V2 - SN: 1051**

Calibration procedure(s) **QA CAL-05.v9**
Calibration procedure for dipole validation kits above 700 MHz

Calibration date: **April 10, 2014**

✓
 KOK
 5/7/14

This calibration certificate documents the traceability to national standards, which realize the physical units of measurements (SI).
 The measurements and the uncertainties with confidence probability are given on the following pages and are part of the certificate.

All calibrations have been conducted in the closed laboratory facility: environment temperature (22 ± 3)°C and humidity < 70%.

Calibration Equipment used (M&TE critical for calibration)

Primary Standards	ID #	Cal Date (Certificate No.)	Scheduled Calibration
Power meter EPM-442A	GB37480704	09-Oct-13 (No. 217-01827)	Oct-14
Power sensor HP 8481A	US37292783	09-Oct-13 (No. 217-01827)	Oct-14
Power sensor HP 8481A	MY41092317	09-Oct-13 (No. 217-01828)	Oct-14
Reference 20 dB Attenuator	SN: 5058 (20k)	03-Apr-14 (No. 217-01918)	Apr-15
Type-N mismatch combination	SN: 5047.2 / 06327	03-Apr-14 (No. 217-01921)	Apr-15
Reference Probe ES3DV3	SN: 3205	30-Dec-13 (No. ES3-3205_Dec13)	Dec-14
DAE4	SN: 601	25-Apr-13 (No. DAE4-601_Apr13)	Apr-14
Secondary Standards	ID #	Check Date (in house)	Scheduled Check
RF generator R&S SMT-06	100005	04-Aug-99 (in house check Oct-13)	In house check: Oct-16
Network Analyzer HP 8753E	US37390585 S4206	18-Oct-01 (in house check Oct-13)	In house check: Oct-14

Calibrated by: **Israe El-Naouq** Function: **Laboratory Technician** Signature: *Israe El-Naouq*

Approved by: **Katja Pokovic** Technical Manager *Katja Pokovic*

Issued: April 10, 2014

This calibration certificate shall not be reproduced except in full without written approval of the laboratory.



Accredited by the Swiss Accreditation Service (SAS)
The Swiss Accreditation Service is one of the signatories to the EA
Multilateral Agreement for the recognition of calibration certificates

Accreditation No.: **SCS 108**

Glossary:

TSL	tissue simulating liquid
ConvF	sensitivity in TSL / NORM x,y,z
N/A	not applicable or not measured

Calibration is Performed According to the Following Standards:

- IEEE Std 1528-2013, "IEEE Recommended Practice for Determining the Peak Spatial-Averaged Specific Absorption Rate (SAR) in the Human Head from Wireless Communications Devices: Measurement Techniques", June 2013
- IEC 62209-1, "Procedure to measure the Specific Absorption Rate (SAR) for hand-held devices used in close proximity to the ear (frequency range of 300 MHz to 3 GHz)", February 2005
- KDB 865664, "SAR Measurement Requirements for 100 MHz to 6 GHz"

Additional Documentation:

- DASY4/5 System Handbook

Methods Applied and Interpretation of Parameters:

- Measurement Conditions:* Further details are available from the Validation Report at the end of the certificate. All figures stated in the certificate are valid at the frequency indicated.
- Antenna Parameters with TSL:* The dipole is mounted with the spacer to position its feed point exactly below the center marking of the flat phantom section, with the arms oriented parallel to the body axis.
- Feed Point Impedance and Return Loss:* These parameters are measured with the dipole positioned under the liquid filled phantom. The impedance stated is transformed from the measurement at the SMA connector to the feed point. The Return Loss ensures low reflected power. No uncertainty required.
- Electrical Delay:* One-way delay between the SMA connector and the antenna feed point. No uncertainty required.
- SAR measured:* SAR measured at the stated antenna input power.
- SAR normalized:* SAR as measured, normalized to an input power of 1 W at the antenna connector.
- SAR for nominal TSL parameters:* The measured TSL parameters are used to calculate the nominal SAR result.

The reported uncertainty of measurement is stated as the standard uncertainty of measurement multiplied by the coverage factor $k=2$, which for a normal distribution corresponds to a coverage probability of approximately 95%.

Measurement Conditions

DASY system configuration, as far as not given on page 1.

DASY Version	DASY5	V52.8.7
Extrapolation	Advanced Extrapolation	
Phantom	Modular Flat Phantom	
Distance Dipole Center - TSL	10 mm	with Spacer
Zoom Scan Resolution	dx, dy, dz = 5 mm	
Frequency	1750 MHz \pm 1 MHz	

Head TSL parameters

The following parameters and calculations were applied.

	Temperature	Permittivity	Conductivity
Nominal Head TSL parameters	22.0 °C	40.1	1.37 mho/m
Measured Head TSL parameters	(22.0 \pm 0.2) °C	39.1 \pm 6 %	1.35 mho/m \pm 6 %
Head TSL temperature change during test	< 0.5 °C	----	----

SAR result with Head TSL

SAR averaged over 1 cm ³ (1 g) of Head TSL	Condition	
SAR measured	250 mW input power	9.02 W/kg
SAR for nominal Head TSL parameters	normalized to 1W	36.2 W/kg \pm 17.0 % (k=2)

SAR averaged over 10 cm ³ (10 g) of Head TSL	condition	
SAR measured	250 mW input power	4.79 W/kg
SAR for nominal Head TSL parameters	normalized to 1W	19.2 W/kg \pm 16.5 % (k=2)

Body TSL parameters

The following parameters and calculations were applied.

	Temperature	Permittivity	Conductivity
Nominal Body TSL parameters	22.0 °C	53.4	1.49 mho/m
Measured Body TSL parameters	(22.0 \pm 0.2) °C	52.0 \pm 6 %	1.48 mho/m \pm 6 %
Body TSL temperature change during test	< 0.5 °C	----	----

SAR result with Body TSL

SAR averaged over 1 cm ³ (1 g) of Body TSL	Condition	
SAR measured	250 mW input power	9.37 W/kg
SAR for nominal Body TSL parameters	normalized to 1W	37.4 W/kg \pm 17.0 % (k=2)

SAR averaged over 10 cm ³ (10 g) of Body TSL	condition	
SAR measured	250 mW input power	5.04 W/kg
SAR for nominal Body TSL parameters	normalized to 1W	20.1 W/kg \pm 16.5 % (k=2)

Appendix

Antenna Parameters with Head TSL

Impedance, transformed to feed point	50.7 Ω + 0.4 j Ω
Return Loss	- 41.5 dB

Antenna Parameters with Body TSL

Impedance, transformed to feed point	46.8 Ω + 0.8 j Ω
Return Loss	- 29.3 dB

General Antenna Parameters and Design

Electrical Delay (one direction)	1.222 ns
----------------------------------	----------

After long term use with 100W radiated power, only a slight warming of the dipole near the feedpoint can be measured.

The dipole is made of standard semirigid coaxial cable. The center conductor of the feeding line is directly connected to the second arm of the dipole. The antenna is therefore short-circuited for DC-signals. On some of the dipoles, small end caps are added to the dipole arms in order to improve matching when loaded according to the position as explained in the "Measurement Conditions" paragraph. The SAR data are not affected by this change. The overall dipole length is still according to the Standard.

No excessive force must be applied to the dipole arms, because they might bend or the soldered connections near the feedpoint may be damaged.

Additional EUT Data

Manufactured by	SPEAG
Manufactured on	February 19, 2010

DASY5 Validation Report for Head TSL

Date: 10.04.2014

Test Laboratory: SPEAG, Zurich, Switzerland

DUT: Dipole 1750 MHz; Type: D1750V2; Serial: D1750V2 - SN: 1051

Communication System: UID 0 - CW; Frequency: 1750 MHz

Medium parameters used: $f = 1750$ MHz; $\sigma = 1.35$ S/m; $\epsilon_r = 39.1$; $\rho = 1000$ kg/m³

Phantom section: Flat Section

Measurement Standard: DASY5 (IEEE/IEC/ANSI C63.19-2007)

DASY52 Configuration:

- Probe: ES3DV3 - SN3205; ConvF(5.23, 5.23, 5.23); Calibrated: 30.12.2013;
- Sensor-Surface: 3mm (Mechanical Surface Detection)
- Electronics: DAE4 Sn601; Calibrated: 25.04.2013
- Phantom: Flat Phantom 5.0 (front); Type: QD000P50AA; Serial: 1001
- DASY52 52.8.7(1137); SEMCAD X 14.6.10(7164)

Dipole Calibration for Head Tissue/Pin=250 mW, d=10mm/Zoom Scan (7x7x7)/Cube 0:

Measurement grid: dx=5mm, dy=5mm, dz=5mm

Reference Value = 94.631 V/m; Power Drift = 0.00 dB

Peak SAR (extrapolated) = 16.2 W/kg

SAR(1 g) = 9.02 W/kg; SAR(10 g) = 4.79 W/kg

Maximum value of SAR (measured) = 11.3 W/kg

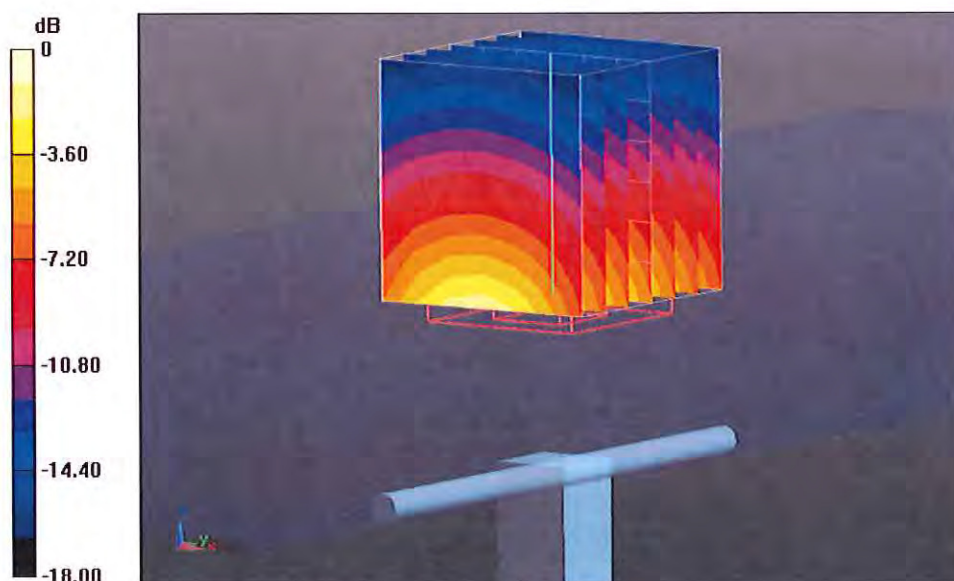

Impedance Measurement Plot for Head TSL

10 Apr 2014 12:21:05

CH1 S11 1 U FS 1: 50.727 Ω 0.4238 Ω 38.545 μH 1: 750.000 000 MHz

*
Del
CA
Avg
16
H1d

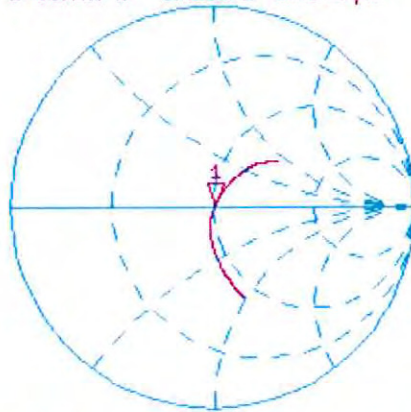

CH2 S11 LOG 5 dB/REF -20 dB 1:-41.536 dB 1: 750.000 000 MHz

CA
Avg
16
H1d

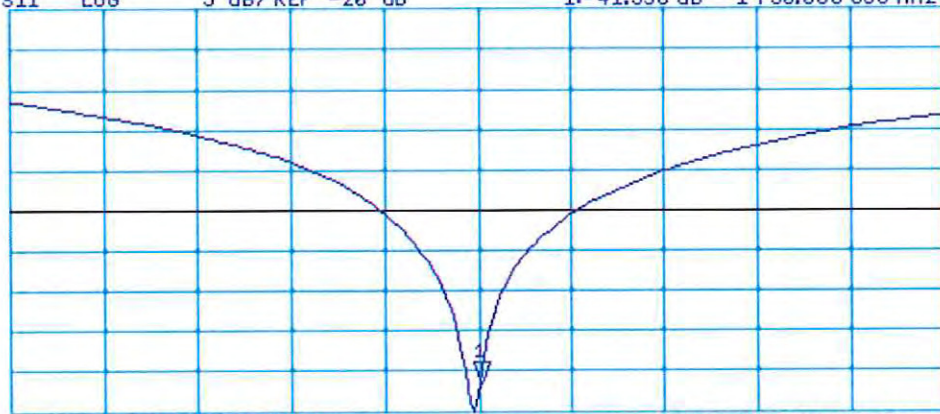

START 1 550.000 000 MHz

STOP 1 950.000 000 MHz

DASY5 Validation Report for Body TSL

Date: 10.04.2014

Test Laboratory: SPEAG, Zurich, Switzerland

DUT: Dipole 1750 MHz; Type: D1750V2; Serial: D1750V2 - SN: 1051

Communication System: UID 0 - CW; Frequency: 1750 MHz

Medium parameters used: $f = 1750$ MHz; $\sigma = 1.48$ S/m; $\epsilon_r = 52$; $\rho = 1000$ kg/m³

Phantom section: Flat Section

Measurement Standard: DASY5 (IEEE/IEC/ANSI C63.19-2007)

DASY52 Configuration:

- Probe: ES3DV3 - SN3205; ConvF(4.89, 4.89, 4.89); Calibrated: 30.12.2013;
- Sensor-Surface: 3mm (Mechanical Surface Detection)
- Electronics: DAE4 Sn601; Calibrated: 25.04.2013
- Phantom: Flat Phantom 5.0 (back); Type: QD000P50AA; Serial: 1002
- DASY52 52.8.7(1137); SEMCAD X 14.6.10(7164)

Dipole Calibration for Body Tissue/Pin=250 mW, d=10mm/Zoom Scan (7x7x7)/Cube 0:

Measurement grid: dx=5mm, dy=5mm, dz=5mm

Reference Value = 93.321 V/m; Power Drift = -0.01 dB

Peak SAR (extrapolated) = 16.1 W/kg

SAR(1 g) = 9.37 W/kg; SAR(10 g) = 5.04 W/kg

Maximum value of SAR (measured) = 11.8 W/kg

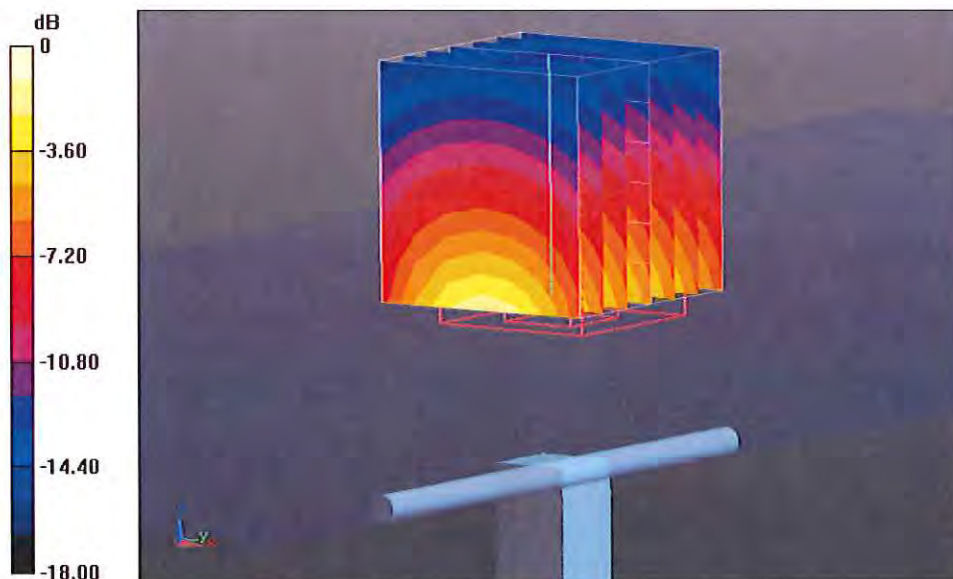

Impedance Measurement Plot for Body TSL

10 Apr 2014 12:20:40

[CH1] S11 1 U FS 1: 46.787 Ω 0.8086 Ω 73.538 pF 1 750.000 000 MHz

*
De l
CA

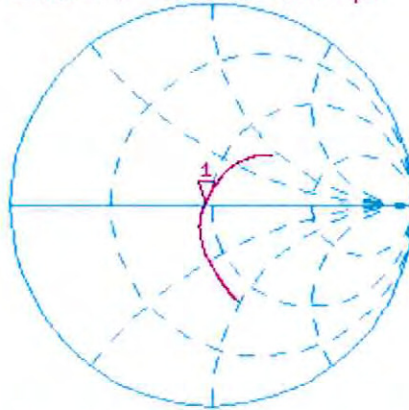

Avg
16

H1 d

CH2 S11 LOG 5 dB/ REF -20 dB 1: -29.320 dB 1 750.000 000 MHz

CA

Avg
16

H1 d

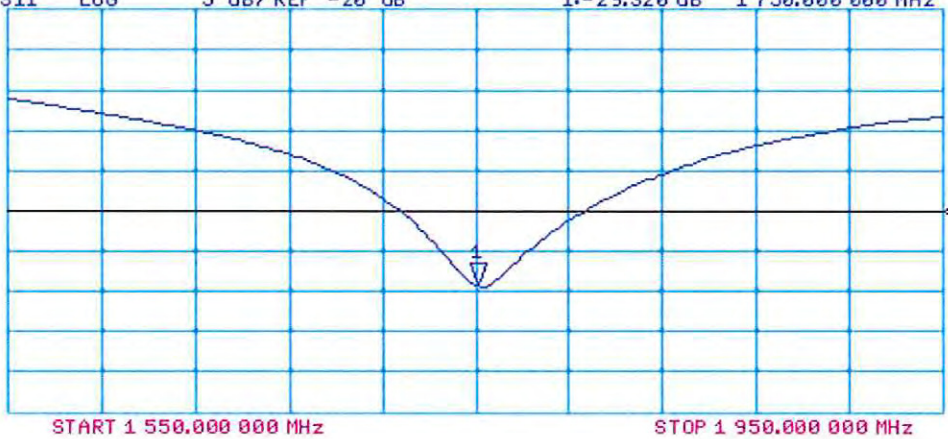



Accredited by the Swiss Accreditation Service (SAS)
The Swiss Accreditation Service is one of the signatories to the EA
Multilateral Agreement for the recognition of calibration certificates

Accreditation No.: **SCS 108**

Client **PC Test**

Certificate No: **D2450V2-719_Aug13**

CALIBRATION CERTIFICATE

Object **D2450V2 - SN: 719**

Calibration procedure(s) **QA CAL-05.v9
Calibration procedure for dipole validation kits above 700 MHz**

Calibration date: **August 23, 2013**

*✓cc
9/13/13*

This calibration certificate documents the traceability to national standards, which realize the physical units of measurements (SI).
The measurements and the uncertainties with confidence probability are given on the following pages and are part of the certificate.

All calibrations have been conducted in the closed laboratory facility: environment temperature (22 ± 3)°C and humidity < 70%.

Calibration Equipment used (M&TE critical for calibration)

Primary Standards	ID #	Cal Date (Certificate No.)	Scheduled Calibration
Power meter EPM-442A	GB37480704	01-Nov-12 (No. 217-01640)	Oct-13
Power sensor HP 8481A	US37292783	01-Nov-12 (No. 217-01640)	Oct-13
Reference 20 dB Attenuator	SN: 5058 (20k)	04-Apr-13 (No. 217-01736)	Apr-14
Type-N mismatch combination	SN: 5047.3 / 06327	04-Apr-13 (No. 217-01739)	Apr-14
Reference Probe ES3DV3	SN: 3205	28-Dec-12 (No. ES3-3205_Dec12)	Dec-13
DAE4	SN: 601	25-Apr-13 (No. DAE4-601_Apr13)	Apr-14
Secondary Standards	ID #	Check Date (in house)	Scheduled Check
Power sensor HP 8481A	MY41092317	18-Oct-02 (in house check Oct-11)	In house check: Oct-13
RF generator R&S SMT-06	100005	04-Aug-99 (in house check Oct-11)	In house check: Oct-13
Network Analyzer HP 8753E	US37390585 S4206	18-Oct-01 (in house check Oct-12)	In house check: Oct-13

Calibrated by:	Name Jeton Kastrati	Function Laboratory Technician	Signature
Approved by:	Name Katja Pokovic	Function Technical Manager	Signature

Issued: August 23, 2013

This calibration certificate shall not be reproduced except in full without written approval of the laboratory.



Accredited by the Swiss Accreditation Service (SAS)

The Swiss Accreditation Service is one of the signatories to the EA
Multilateral Agreement for the recognition of calibration certificates

Accreditation No.: **SCS 108**

Glossary:

TSL	tissue simulating liquid
ConvF	sensitivity in TSL / NORM x,y,z
N/A	not applicable or not measured

Calibration is Performed According to the Following Standards:

- IEEE Std 1528-2003, "IEEE Recommended Practice for Determining the Peak Spatial-Averaged Specific Absorption Rate (SAR) in the Human Head from Wireless Communications Devices: Measurement Techniques", December 2003
- IEC 62209-1, "Procedure to measure the Specific Absorption Rate (SAR) for hand-held devices used in close proximity to the ear (frequency range of 300 MHz to 3 GHz)", February 2005
- KDB 865664, "SAR Measurement Requirements for 100 MHz to 6 GHz"

Additional Documentation:

- DASY4/5 System Handbook

Methods Applied and Interpretation of Parameters:

- Measurement Conditions:* Further details are available from the Validation Report at the end of the certificate. All figures stated in the certificate are valid at the frequency indicated.
- Antenna Parameters with TSL:* The dipole is mounted with the spacer to position its feed point exactly below the center marking of the flat phantom section, with the arms oriented parallel to the body axis.
- Feed Point Impedance and Return Loss:* These parameters are measured with the dipole positioned under the liquid filled phantom. The impedance stated is transformed from the measurement at the SMA connector to the feed point. The Return Loss ensures low reflected power. No uncertainty required.
- Electrical Delay:* One-way delay between the SMA connector and the antenna feed point. No uncertainty required.
- SAR measured:* SAR measured at the stated antenna input power.
- SAR normalized:* SAR as measured, normalized to an input power of 1 W at the antenna connector.
- SAR for nominal TSL parameters:* The measured TSL parameters are used to calculate the nominal SAR result.

The reported uncertainty of measurement is stated as the standard uncertainty of measurement multiplied by the coverage factor $k=2$, which for a normal distribution corresponds to a coverage probability of approximately 95%.

Measurement Conditions

DASY system configuration, as far as not given on page 1.

DASY Version	DASY5	V52.8.7
Extrapolation	Advanced Extrapolation	
Phantom	Modular Flat Phantom	
Distance Dipole Center - TSL	10 mm	with Spacer
Zoom Scan Resolution	dx, dy, dz = 5 mm	
Frequency	2450 MHz \pm 1 MHz	

Head TSL parameters

The following parameters and calculations were applied.

	Temperature	Permittivity	Conductivity
Nominal Head TSL parameters	22.0 °C	39.2	1.80 mho/m
Measured Head TSL parameters	(22.0 \pm 0.2) °C	37.8 \pm 6 %	1.80 mho/m \pm 6 %
Head TSL temperature change during test	< 0.5 °C	----	----

SAR result with Head TSL

SAR averaged over 1 cm³ (1 g) of Head TSL	Condition	
SAR measured	250 mW input power	13.4 W/kg
SAR for nominal Head TSL parameters	normalized to 1W	53.2 W/kg \pm 17.0 % (k=2)

SAR averaged over 10 cm³ (10 g) of Head TSL	condition	
SAR measured	250 mW input power	6.23 W/kg
SAR for nominal Head TSL parameters	normalized to 1W	24.8 W/kg \pm 16.5 % (k=2)

Body TSL parameters

The following parameters and calculations were applied.

	Temperature	Permittivity	Conductivity
Nominal Body TSL parameters	22.0 °C	52.7	1.95 mho/m
Measured Body TSL parameters	(22.0 \pm 0.2) °C	50.6 \pm 6 %	2.03 mho/m \pm 6 %
Body TSL temperature change during test	< 0.5 °C	----	----

SAR result with Body TSL

SAR averaged over 1 cm³ (1 g) of Body TSL	Condition	
SAR measured	250 mW input power	13.3 W/kg
SAR for nominal Body TSL parameters	normalized to 1W	51.7 W/kg \pm 17.0 % (k=2)

SAR averaged over 10 cm³ (10 g) of Body TSL	condition	
SAR measured	250 mW input power	6.14 W/kg
SAR for nominal Body TSL parameters	normalized to 1W	24.1 W/kg \pm 16.5 % (k=2)

Appendix

Antenna Parameters with Head TSL

Impedance, transformed to feed point	54.6 Ω + 3.5 j Ω
Return Loss	- 25.1 dB

Antenna Parameters with Body TSL

Impedance, transformed to feed point	51.1 Ω + 5.4 j Ω
Return Loss	- 25.3 dB

General Antenna Parameters and Design

Electrical Delay (one direction)	1.149 ns
----------------------------------	----------

After long term use with 100W radiated power, only a slight warming of the dipole near the feedpoint can be measured.

The dipole is made of standard semirigid coaxial cable. The center conductor of the feeding line is directly connected to the second arm of the dipole. The antenna is therefore short-circuited for DC-signals. On some of the dipoles, small end caps are added to the dipole arms in order to improve matching when loaded according to the position as explained in the "Measurement Conditions" paragraph. The SAR data are not affected by this change. The overall dipole length is still according to the Standard.

No excessive force must be applied to the dipole arms, because they might bend or the soldered connections near the feedpoint may be damaged.

Additional EUT Data

Manufactured by	SPEAG
Manufactured on	September 10, 2002

DASY5 Validation Report for Head TSL

Date: 22.08.2013

Test Laboratory: SPEAG, Zurich, Switzerland

DUT: Dipole 2450 MHz; Type: D2450V2; Serial: D2450V2 - SN: 719

Communication System: UID 0 - CW ; Frequency: 2450 MHz

Medium parameters used: $f = 2450$ MHz; $\sigma = 1.8$ S/m; $\epsilon_r = 37.8$; $\rho = 1000$ kg/m³

Phantom section: Flat Section

Measurement Standard: DASY5 (IEEE/IEC/ANSI C63.19-2007)

DASY52 Configuration:

- Probe: ES3DV3 - SN3205; ConvF(4.52, 4.52, 4.52); Calibrated: 28.12.2012;
- Sensor-Surface: 3mm (Mechanical Surface Detection)
- Electronics: DAE4 Sn601; Calibrated: 25.04.2013
- Phantom: Flat Phantom 5.0 (front); Type: QD000P50AA; Serial: 1001
- DASY52 52.8.7(1137); SEMCAD X 14.6.10(7164)

Dipole Calibration for Head Tissue/Pin=250 mW, d=10mm/Zoom Scan (7x7x7)/Cube 0:

Measurement grid: dx=5mm, dy=5mm, dz=5mm

Reference Value = 100.7 V/m; Power Drift = 0.06 dB

Peak SAR (extrapolated) = 27.9 W/kg

SAR(1 g) = 13.4 W/kg; SAR(10 g) = 6.23 W/kg

Maximum value of SAR (measured) = 17.0 W/kg

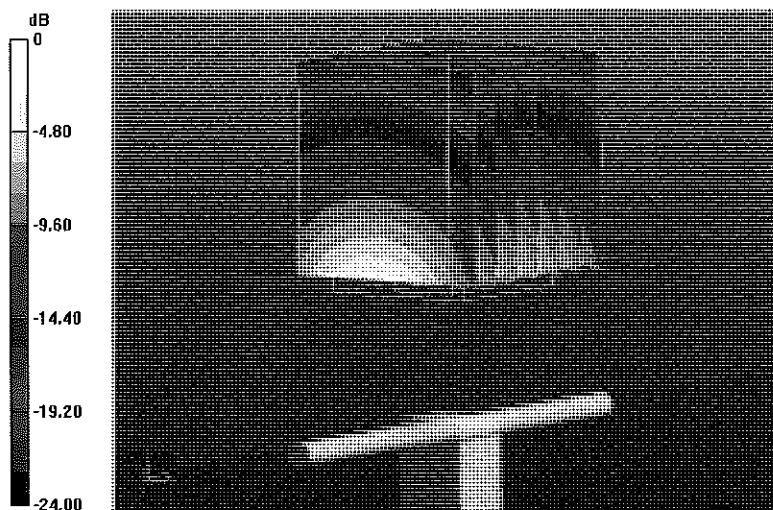

0 dB = 17.0 W/kg = 12.30 dBW/kg

Impedance Measurement Plot for Head TSL

22 Aug 2013 11:00:15

CH1 S11 1 U FS

4: 54.639 Ω 3.5215 Ω 228.76 pF

2 450.000 000 MHz

*
De1

CA

Avg
16

H1d

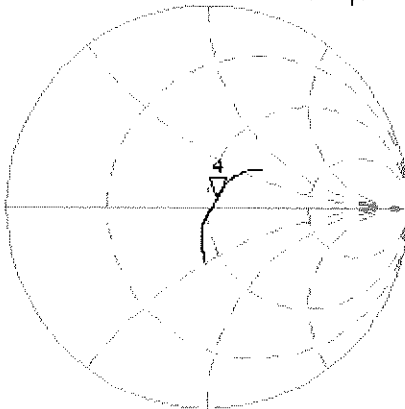

CH2 S11 LOG

5 dB/REF -20 dB

4: -25.093 dB 2 450.000 000 MHz

CA

Avg
16

H1d

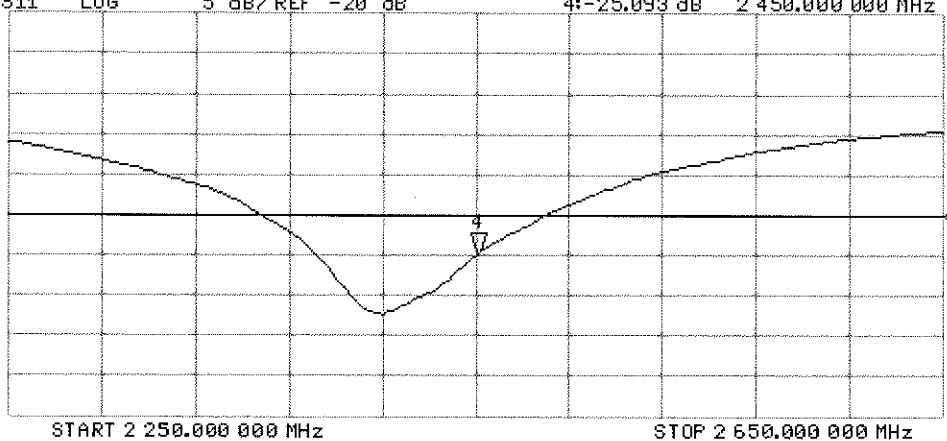

DASY5 Validation Report for Body TSL

Date: 23.08.2013

Test Laboratory: SPEAG, Zurich, Switzerland

DUT: Dipole 2450 MHz; Type: D2450V2; Serial: D2450V2 - SN: 719

Communication System: UID 0 - CW ; Frequency: 2450 MHz

Medium parameters used: $f = 2450$ MHz; $\sigma = 2.03$ S/m; $\epsilon_r = 50.6$; $\rho = 1000$ kg/m³

Phantom section: Flat Section

Measurement Standard: DASY5 (IEEE/IEC/ANSI C63.19-2007)

DASY52 Configuration:

- Probe: ES3DV3 - SN3205; ConvF(4.42, 4.42, 4.42); Calibrated: 28.12.2012;
- Sensor-Surface: 3mm (Mechanical Surface Detection)
- Electronics: DAE4 Sn601; Calibrated: 25.04.2013
- Phantom: Flat Phantom 5.0 (back); Type: QD000P50AA; Serial: 1002
- DASY52 52.8.7(1137); SEMCAD X 14.6.10(7164)

Dipole Calibration for Body Tissue/Pin=250 mW, d=10mm/Zoom Scan (7x7x7)/Cube 0:

Measurement grid: dx=5mm, dy=5mm, dz=5mm

Reference Value = 94.688 V/m; Power Drift = 0.06 dB

Peak SAR (extrapolated) = 27.9 W/kg

SAR(1 g) = 13.3 W/kg; SAR(10 g) = 6.14 W/kg

Maximum value of SAR (measured) = 17.2 W/kg

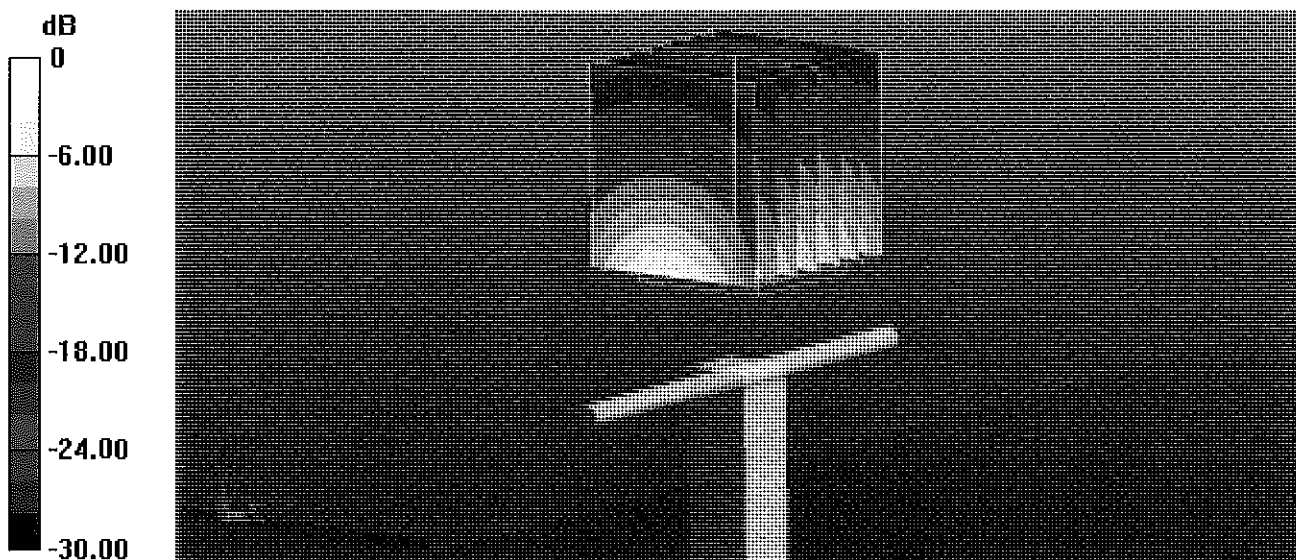

0 dB = 17.2 W/kg = 12.36 dBW/kg

Impedance Measurement Plot for Body TSL

23 Aug 2013 09:00:38

CH1 S11 1 U FS

3: 51.135 Ω 5.3965 Ω 350.56 μH

2 450.000 000 MHz

#

De1

CΔ

Avg

16

H1 d

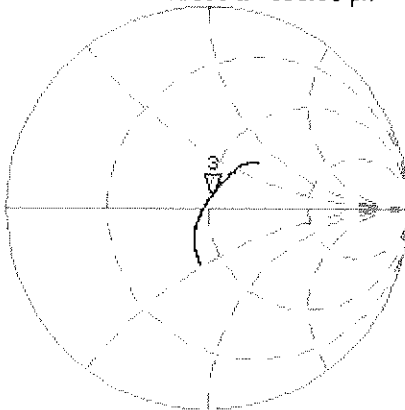

CH2 S11 LOG

5 dB/REF -20 dB

3:-25.274 dB

2 450.000 000 MHz

CΔ

Avg

16

H1 d

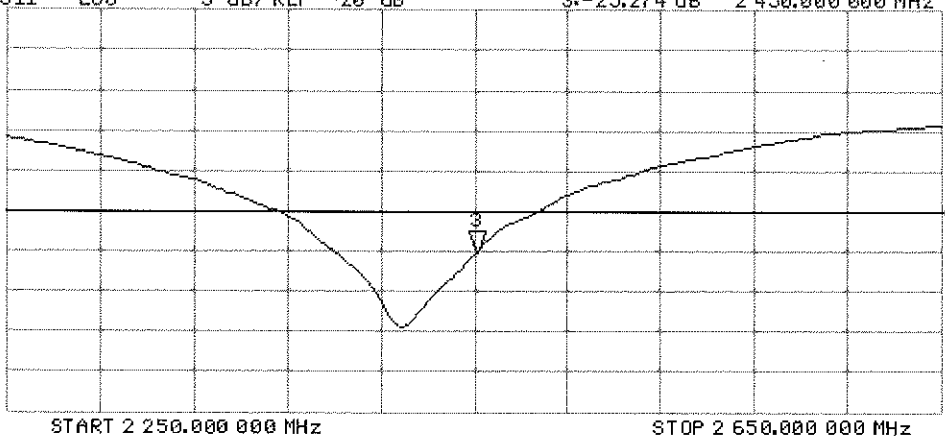



Accredited by the Swiss Accreditation Service (SAS)
The Swiss Accreditation Service is one of the signatories to the EA
Multilateral Agreement for the recognition of calibration certificates

Accreditation No.: **SCS 108**

Client **PC Test**

Certificate No: **D5GHzV2-1007_Sep13/2**

CALIBRATION CERTIFICATE (Replacement of No: D5GHzV2-1007_Sep13)

Object **D5GHzV2 - SN: 1007**

Calibration procedure(s) **QA CAL-22.v2
Calibration procedure for dipole validation kits between 3-6 GHz**

CC✓
10/15/13

Calibration date: **September 23, 2013**

This calibration certificate documents the traceability to national standards, which realize the physical units of measurements (SI).
The measurements and the uncertainties with confidence probability are given on the following pages and are part of the certificate.

All calibrations have been conducted in the closed laboratory facility: environment temperature (22 ± 3)°C and humidity < 70%.

Calibration Equipment used (M&TE critical for calibration)

Primary Standards	ID #	Cal Date (Certificate No.)	Scheduled Calibration
Power meter EPM-442A	GB37480704	01-Nov-12 (No. 217-01640)	Oct-13
Power sensor HP 8481A	US37292783	01-Nov-12 (No. 217-01640)	Oct-13
Reference 20 dB Attenuator	SN: 5058 (20k)	04-Apr-13 (No. 217-01736)	Apr-14
Type-N mismatch combination	SN: 5047.3 / 06327	04-Apr-13 (No. 217-01739)	Apr-14
Reference Probe EX3DV4	SN: 3503	28-Dec-12 (No. EX3-3503_Dec12)	Dec-13
DAE4	SN: 601	25-Apr-13 (No. DAE4-601_Apr13)	Apr-14
Secondary Standards	ID #	Check Date (in house)	Scheduled Check
Power sensor HP 8481A	MY41092317	18-Oct-02 (in house check Oct-11)	In house check: Oct-13
RF generator R&S SMT-06	100005	04-Aug-99 (in house check Oct-11)	In house check: Oct-13
Network Analyzer HP 8753E	US37390585 S4206	18-Oct-01 (in house check Oct-12)	In house check: Oct-13

Calibrated by: **Leif Klysner** (Name) / **Laboratory Technician** (Function) / *[Signature]* (Signature)

Approved by: **Katja Pokovic** (Name) / **Technical Manager** (Function) / *[Signature]* (Signature)

Issued: October 4, 2013

This calibration certificate shall not be reproduced except in full without written approval of the laboratory.



Accredited by the Swiss Accreditation Service (SAS)
The Swiss Accreditation Service is one of the signatories to the EA
Multilateral Agreement for the recognition of calibration certificates

Accreditation No.: **SCS 108**

Glossary:

TSL	tissue simulating liquid
ConvF	sensitivity in TSL / NORM x,y,z
N/A	not applicable or not measured

Calibration is Performed According to the Following Standards:

- IEC 62209-2, "Evaluation of Human Exposure to Radio Frequency Fields from Handheld and Body-Mounted Wireless Communication Devices in the Frequency Range of 30 MHz to 6 GHz: Human models, Instrumentation, and Procedures"; Part 2: "Procedure to determine the Specific Absorption Rate (SAR) for including accessories and multiple transmitters", March 2010
- KDB 865664, "SAR Measurement Requirements for 100 MHz to 6 GHz"
- IEEE Std 1528-2013, "IEEE Recommended Practice for Determining the Peak Spatial-Averaged Specific Absorption Rate (SAR) in the Human Head from Wireless Communications Devices: Measurement Techniques", June 2013

Additional Documentation:

- DASY4/5 System Handbook

Methods Applied and Interpretation of Parameters:

- Measurement Conditions:** Further details are available from the Validation Report at the end of the certificate. All figures stated in the certificate are valid at the frequency indicated.
- Antenna Parameters with TSL:** The dipole is mounted with the spacer to position its feed point exactly below the center marking of the flat phantom section, with the arms oriented parallel to the body axis.
- Feed Point Impedance and Return Loss:** These parameters are measured with the dipole positioned under the liquid filled phantom. The impedance stated is transformed from the measurement at the SMA connector to the feed point. The Return Loss ensures low reflected power. No uncertainty required.
- Electrical Delay:** One-way delay between the SMA connector and the antenna feed point. No uncertainty required.
- SAR measured:** SAR measured at the stated antenna input power.
- SAR normalized:** SAR as measured, normalized to an input power of 1 W at the antenna connector.
- SAR for nominal TSL parameters:** The measured TSL parameters are used to calculate the nominal SAR result.

The reported uncertainty of measurement is stated as the standard uncertainty of measurement multiplied by the coverage factor $k=2$, which for a normal distribution corresponds to a coverage probability of approximately 95%.

Measurement Conditions

DASY system configuration, as far as not given on page 1.

DASY Version	DASY5	V52.8.7
Extrapolation	Advanced Extrapolation	
Phantom	Modular Flat Phantom V5.0	
Distance Dipole Center - TSL	10 mm	with Spacer
Zoom Scan Resolution	dx, dy = 4.0 mm, dz = 1.4 mm	Graded Ratio = 1.4 (Z direction)
Frequency	5200 MHz ± 1 MHz 5300 MHz ± 1 MHz 5500 MHz ± 1 MHz 5600 MHz ± 1 MHz 5800 MHz ± 1 MHz	

Head TSL parameters at 5200 MHz

The following parameters and calculations were applied.

	Temperature	Permittivity	Conductivity
Nominal Head TSL parameters	22.0 °C	36.0	4.66 mho/m
Measured Head TSL parameters	(22.0 ± 0.2) °C	35.8 ± 6 %	4.48 mho/m ± 6 %
Head TSL temperature change during test	< 0.5 °C	----	----

SAR result with Head TSL at 5200 MHz

SAR averaged over 1 cm³ (1 g) of Head TSL	Condition	
SAR measured	100 mW input power	7.77 W/kg
SAR for nominal Head TSL parameters	normalized to 1W	77.5 W/kg ± 19.9 % (k=2)

SAR averaged over 10 cm³ (10 g) of Head TSL	condition	
SAR measured	100 mW input power	2.23 W/kg
SAR for nominal Head TSL parameters	normalized to 1W	22.2 W/kg ± 19.5 % (k=2)

Head TSL parameters at 5300 MHz

The following parameters and calculations were applied.

	Temperature	Permittivity	Conductivity
Nominal Head TSL parameters	22.0 °C	35.9	4.76 mho/m
Measured Head TSL parameters	(22.0 ± 0.2) °C	35.6 ± 6 %	4.62 mho/m ± 6 %
Head TSL temperature change during test	< 0.5 °C	----	----

SAR result with Head TSL at 5300 MHz

SAR averaged over 1 cm ³ (1 g) of Head TSL	Condition	
SAR measured	100 mW input power	8.04 W/kg
SAR for nominal Head TSL parameters	normalized to 1W	80.2 W / kg ± 19.9 % (k=2)

SAR averaged over 10 cm ³ (10 g) of Head TSL	condition	
SAR measured	100 mW input power	2.30 W/kg
SAR for nominal Head TSL parameters	normalized to 1W	22.9 W/kg ± 19.5 % (k=2)

Head TSL parameters at 5500 MHz

The following parameters and calculations were applied.

	Temperature	Permittivity	Conductivity
Nominal Head TSL parameters	22.0 °C	35.6	4.96 mho/m
Measured Head TSL parameters	(22.0 ± 0.2) °C	35.4 ± 6 %	4.76 mho/m ± 6 %
Head TSL temperature change during test	< 0.5 °C	----	----

SAR result with Head TSL at 5500 MHz

SAR averaged over 1 cm ³ (1 g) of Head TSL	Condition	
SAR measured	100 mW input power	8.17 W/kg
SAR for nominal Head TSL parameters	normalized to 1W	81.4 W/kg ± 19.9 % (k=2)

SAR averaged over 10 cm ³ (10 g) of Head TSL	condition	
SAR measured	100 mW input power	2.32 W/kg
SAR for nominal Head TSL parameters	normalized to 1W	23.1 W/kg ± 19.5 % (k=2)

Head TSL parameters at 5600 MHz

The following parameters and calculations were applied.

	Temperature	Permittivity	Conductivity
Nominal Head TSL parameters	22.0 °C	35.5	5.07 mho/m
Measured Head TSL parameters	(22.0 ± 0.2) °C	35.2 ± 6 %	4.86 mho/m ± 6 %
Head TSL temperature change during test	< 0.5 °C	----	----

SAR result with Head TSL at 5600 MHz

SAR averaged over 1 cm ³ (1 g) of Head TSL	Condition	
SAR measured	100 mW input power	8.03 W/kg
SAR for nominal Head TSL parameters	normalized to 1W	80.0 W/kg ± 19.9 % (k=2)

SAR averaged over 10 cm ³ (10 g) of Head TSL	condition	
SAR measured	100 mW input power	2.28 W/kg
SAR for nominal Head TSL parameters	normalized to 1W	22.7 W/kg ± 19.5 % (k=2)

Head TSL parameters at 5800 MHz

The following parameters and calculations were applied.

	Temperature	Permittivity	Conductivity
Nominal Head TSL parameters	22.0 °C	35.3	5.27 mho/m
Measured Head TSL parameters	(22.0 ± 0.2) °C	35.0 ± 6 %	5.07 mho/m ± 6 %
Head TSL temperature change during test	< 0.5 °C	----	----

SAR result with Head TSL at 5800 MHz

SAR averaged over 1 cm ³ (1 g) of Head TSL	Condition	
SAR measured	100 mW input power	7.78 W/kg
SAR for nominal Head TSL parameters	normalized to 1W	77.5 W/kg ± 19.9 % (k=2)

SAR averaged over 10 cm ³ (10 g) of Head TSL	condition	
SAR measured	100 mW input power	2.20 W/kg
SAR for nominal Head TSL parameters	normalized to 1W	21.9 W/kg ± 19.5 % (k=2)

Body TSL parameters at 5200 MHz

The following parameters and calculations were applied.

	Temperature	Permittivity	Conductivity
Nominal Body TSL parameters	22.0 °C	49.0	5.30 mho/m
Measured Body TSL parameters	(22.0 ± 0.2) °C	48.3 ± 6 %	5.36 mho/m ± 6 %
Body TSL temperature change during test	< 0.5 °C	----	----

SAR result with Body TSL at 5200 MHz

SAR averaged over 1 cm ³ (1 g) of Body TSL	Condition	
SAR measured	100 mW input power	7.28 W/kg
SAR for nominal Body TSL parameters	normalized to 1W	72.6 W/kg ± 19.9 % (k=2)

SAR averaged over 10 cm ³ (10 g) of Body TSL	condition	
SAR measured	100 mW input power	2.03 W/kg
SAR for nominal Body TSL parameters	normalized to 1W	20.2 W/kg ± 19.5 % (k=2)

Body TSL parameters at 5300 MHz

The following parameters and calculations were applied.

	Temperature	Permittivity	Conductivity
Nominal Body TSL parameters	22.0 °C	48.9	5.42 mho/m
Measured Body TSL parameters	(22.0 ± 0.2) °C	48.1 ± 6 %	5.56 mho/m ± 6 %
Body TSL temperature change during test	< 0.5 °C	----	----

SAR result with Body TSL at 5300 MHz

SAR averaged over 1 cm ³ (1 g) of Body TSL	Condition	
SAR measured	100 mW input power	7.49 W/kg
SAR for nominal Body TSL parameters	normalized to 1W	74.7 W/kg ± 19.9 % (k=2)

SAR averaged over 10 cm ³ (10 g) of Body TSL	condition	
SAR measured	100 mW input power	2.09 W/kg
SAR for nominal Body TSL parameters	normalized to 1W	20.8 W/kg ± 19.5 % (k=2)

Body TSL parameters at 5500 MHz

The following parameters and calculations were applied.

	Temperature	Permittivity	Conductivity
Nominal Body TSL parameters	22.0 °C	48.6	5.65 mho/m
Measured Body TSL parameters	(22.0 ± 0.2) °C	47.8 ± 6 %	5.75 mho/m ± 6 %
Body TSL temperature change during test	< 0.5 °C	----	----

SAR result with Body TSL at 5500 MHz

SAR averaged over 1 cm ³ (1 g) of Body TSL	Condition	
SAR measured	100 mW input power	7.61 W/kg
SAR for nominal Body TSL parameters	normalized to 1W	75.9 W/kg ± 19.9 % (k=2)

SAR averaged over 10 cm ³ (10 g) of Body TSL	condition	
SAR measured	100 mW input power	2.11 W/kg
SAR for nominal Body TSL parameters	normalized to 1W	21.0 W/kg ± 19.5 % (k=2)

Body TSL parameters at 5600 MHz

The following parameters and calculations were applied.

	Temperature	Permittivity	Conductivity
Nominal Body TSL parameters	22.0 °C	48.5	5.77 mho/m
Measured Body TSL parameters	(22.0 ± 0.2) °C	47.6 ± 6 %	5.88 mho/m ± 6 %
Body TSL temperature change during test	< 0.5 °C	----	----

SAR result with Body TSL at 5600 MHz

SAR averaged over 1 cm ³ (1 g) of Body TSL	Condition	
SAR measured	100 mW input power	7.75 W/kg
SAR for nominal Body TSL parameters	normalized to 1W	77.3 W/kg ± 19.9 % (k=2)

SAR averaged over 10 cm ³ (10 g) of Body TSL	condition	
SAR measured	100 mW input power	2.16 W/kg
SAR for nominal Body TSL parameters	normalized to 1W	21.5 W/kg ± 19.5 % (k=2)

Body TSL parameters at 5800 MHz

The following parameters and calculations were applied.

	Temperature	Permittivity	Conductivity
Nominal Body TSL parameters	22.0 °C	48.2	6.00 mho/m
Measured Body TSL parameters	(22.0 ± 0.2) °C	47.3 ± 6 %	6.17 mho/m ± 6 %
Body TSL temperature change during test	< 0.5 °C	----	----

SAR result with Body TSL at 5800 MHz

SAR averaged over 1 cm ³ (1 g) of Body TSL	Condition	
SAR measured	100 mW input power	7.31 W/kg
SAR for nominal Body TSL parameters	normalized to 1W	72.9 W/kg ± 19.9 % (k=2)

SAR averaged over 10 cm ³ (10 g) of Body TSL	condition	
SAR measured	100 mW input power	2.02 W/kg
SAR for nominal Body TSL parameters	normalized to 1W	20.1 W/kg ± 19.5 % (k=2)

Appendix

Antenna Parameters with Head TSL at 5200 MHz

Impedance, transformed to feed point	52.4 Ω - 11.0 j Ω
Return Loss	- 19.2 dB

Antenna Parameters with Head TSL at 5300 MHz

Impedance, transformed to feed point	56.8 Ω - 4.4 j Ω
Return Loss	- 22.3 dB

Antenna Parameters with Head TSL at 5500 MHz

Impedance, transformed to feed point	48.8 Ω - 5.4 j Ω
Return Loss	- 25.1 dB

Antenna Parameters with Head TSL at 5600 MHz

Impedance, transformed to feed point	57.3 Ω - 8.7 j Ω
Return Loss	- 19.5 dB

Antenna Parameters with Head TSL at 5800 MHz

Impedance, transformed to feed point	56.9 Ω + 1.6 j Ω
Return Loss	- 23.5 dB

Antenna Parameters with Body TSL at 5200 MHz

Impedance, transformed to feed point	53.1 Ω - 10.3 j Ω
Return Loss	- 19.7 dB

Antenna Parameters with Body TSL at 5300 MHz

Impedance, transformed to feed point	54.3 Ω - 1.5 j Ω
Return Loss	- 27.2 dB

Antenna Parameters with Body TSL at 5500 MHz

Impedance, transformed to feed point	49.7 Ω - 3.6 j Ω
Return Loss	- 28.7 dB

Antenna Parameters with Body TSL at 5600 MHz

Impedance, transformed to feed point	58.2 Ω - 5.2 j Ω
Return Loss	- 20.9 dB

Antenna Parameters with Body TSL at 5800 MHz

Impedance, transformed to feed point	58.7 Ω + 3.9 j Ω
Return Loss	- 21.1 dB

General Antenna Parameters and Design

Electrical Delay (one direction)	1.201 ns
----------------------------------	----------

After long term use with 100W radiated power, only a slight warming of the dipole near the feedpoint can be measured.

The dipole is made of standard semirigid coaxial cable. The center conductor of the feeding line is directly connected to the second arm of the dipole. The antenna is therefore short-circuited for DC-signals. On some of the dipoles, small end caps are added to the dipole arms in order to improve matching when loaded according to the position as explained in the "Measurement Conditions" paragraph. The SAR data are not affected by this change. The overall dipole length is still according to the Standard.

No excessive force must be applied to the dipole arms, because they might bend or the soldered connections near the feedpoint may be damaged.

Additional EUT Data

Manufactured by	SPEAG
Manufactured on	August 28, 2003

DASY5 Validation Report for Head TSL

Date: 23.09.2013

Test Laboratory: SPEAG, Zurich, Switzerland

DUT: Dipole 5GHz; Type: D5GHzV2; Serial: D5GHzV2 - SN: 1007

Communication System: UID 0 - CW ; Frequency: 5200 MHz, Frequency: 5300 MHz, Frequency: 5500 MHz, Frequency: 5600 MHz, Frequency: 5800 MHz

Medium parameters used: $f = 5200$ MHz; $\sigma = 4.48$ S/m; $\epsilon_r = 35.8$; $\rho = 1000$ kg/m³, Medium parameters used: $f = 5300$ MHz; $\sigma = 4.62$ S/m; $\epsilon_r = 35.6$; $\rho = 1000$ kg/m³, Medium parameters used: $f = 5500$ MHz; $\sigma = 4.76$ S/m; $\epsilon_r = 35.4$; $\rho = 1000$ kg/m³, Medium parameters used: $f = 5600$ MHz; $\sigma = 4.86$ S/m; $\epsilon_r = 35.2$; $\rho = 1000$ kg/m³, Medium parameters used: $f = 5800$ MHz; $\sigma = 5.07$ S/m; $\epsilon_r = 35$; $\rho = 1000$ kg/m³

Phantom section: Flat Section

Measurement Standard: DASY5 (IEEE/IEC/ANSI C63.19-2007)

DASY52 Configuration:

- Probe: EX3DV4 - SN3503; ConvF(5.41, 5.41, 5.41); Calibrated: 28.12.2012, ConvF(5.1, 5.1, 5.1); Calibrated: 28.12.2012, ConvF(4.91, 4.91, 4.91); Calibrated: 28.12.2012, ConvF(4.76, 4.76, 4.76); Calibrated: 28.12.2012, ConvF(4.81, 4.81, 4.81); Calibrated: 28.12.2012;
- Sensor-Surface: 1.4mm (Mechanical Surface Detection)
- Electronics: DAE4 Sn601; Calibrated: 25.04.2013
- Phantom: Flat Phantom 5.0 (front); Type: QD000P50AA; Serial: 1001
- DASY52 52.8.7(1137); SEMCAD X 14.6.10(7164)

Dipole Calibration for Head Tissue/Pin=100mW, dist=10mm, f=5200 MHz/Zoom Scan, dist=1.4mm (8x8x7)/Cube 0: Measurement grid: dx=4mm, dy=4mm, dz=1.4mm

Reference Value = 63.505 V/m; Power Drift = 0.07 dB

Peak SAR (extrapolated) = 28.1 W/kg

SAR(1 g) = 7.77 W/kg; SAR(10 g) = 2.23 W/kg

Maximum value of SAR (measured) = 18.1 W/kg

Dipole Calibration for Head Tissue/Pin=100mW, dist=10mm, f=5300 MHz/Zoom Scan, dist=1.4mm (8x8x7)/Cube 0: Measurement grid: dx=4mm, dy=4mm, dz=1.4mm

Reference Value = 63.817 V/m; Power Drift = 0.07 dB

Peak SAR (extrapolated) = 29.7 W/kg

SAR(1 g) = 8.04 W/kg; SAR(10 g) = 2.3 W/kg

Maximum value of SAR (measured) = 18.7 W/kg

Dipole Calibration for Head Tissue/Pin=100mW, dist=10mm, f=5500 MHz/Zoom Scan, dist=1.4mm (8x8x7)/Cube 0: Measurement grid: dx=4mm, dy=4mm, dz=1.4mm

Reference Value = 64.029 V/m; Power Drift = 0.07 dB

Peak SAR (extrapolated) = 32.0 W/kg

SAR(1 g) = 8.17 W/kg; SAR(10 g) = 2.32 W/kg

Maximum value of SAR (measured) = 19.7 W/kg

Dipole Calibration for Head Tissue/Pin=100mW, dist=10mm, f=5600 MHz/Zoom Scan,

dist=1.4mm (8x8x7)/Cube 0: Measurement grid: dx=4mm, dy=4mm, dz=1.4mm

Reference Value = 63.403 V/m; Power Drift = 0.05 dB

Peak SAR (extrapolated) = 31.3 W/kg

SAR(1 g) = 8.03 W/kg; SAR(10 g) = 2.28 W/kg

Maximum value of SAR (measured) = 19.3 W/kg

Dipole Calibration for Head Tissue/Pin=100mW, dist=10mm, f=5800 MHz/Zoom Scan,

dist=1.4mm (8x8x7)/Cube 0: Measurement grid: dx=4mm, dy=4mm, dz=1.4mm

Reference Value = 60.987 V/m; Power Drift = 0.06 dB

Peak SAR (extrapolated) = 31.9 W/kg

SAR(1 g) = 7.78 W/kg; SAR(10 g) = 2.2 W/kg

Maximum value of SAR (measured) = 19.0 W/kg

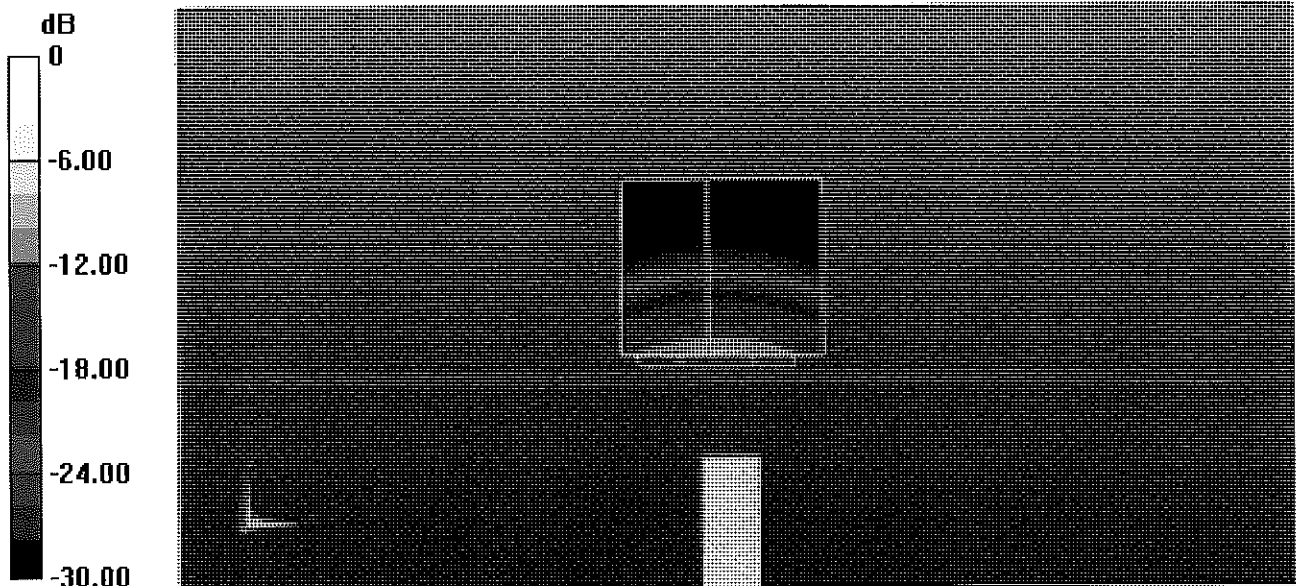

0 dB = 19.0 W/kg = 12.79 dBW/kg

Impedance Measurement Plot for Head TSL

23 Sep 2013 11:11:14

CH1 S11 1 U FS 1: 52.408 Ω -10.990 Ω 2.7849 μ F 5 200.000 000 MHz

*
Del
Cor
Avg
16
H1d

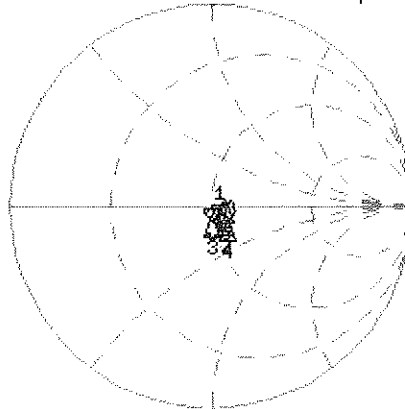

CH1 Markers
2: 56.846 Ω
-4.4492 Ω
5.30000 GHz
3: 48.834 Ω
-5.3730 Ω
5.50000 GHz
4: 57.303 Ω
-8.6738 Ω
5.60000 GHz
5: 56.939 Ω
1.5527 Ω
5.80000 GHz

CH2 S11 L00 5 dB/REF -20 dB 1: -19.232 dB 5 200.000 000 MHz

Cor
Avg
16
H1d

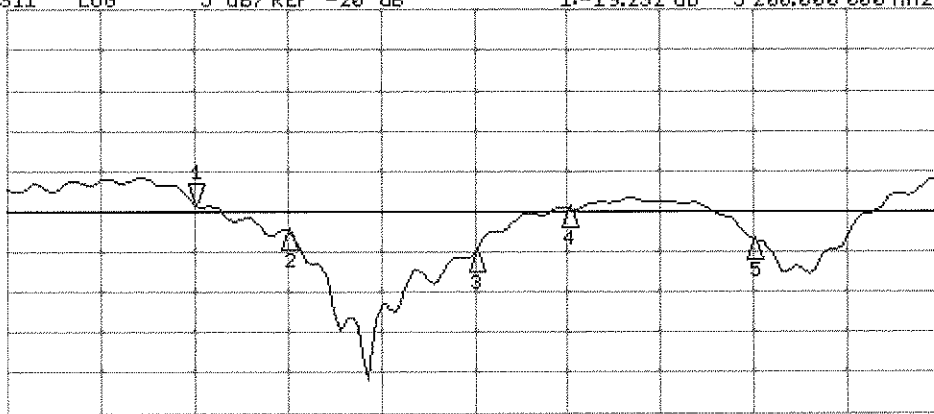

CH2 Markers
2: -22.341 dB
5.30000 GHz
3: -25.105 dB
5.50000 GHz
4: -19.547 dB
5.60000 GHz
5: -23.545 dB
5.80000 GHz

START 5 000.000 000 MHz

STOP 6 000.000 000 MHz

DASY5 Validation Report for Body TSL

Date: 20.09.2013

Test Laboratory: SPEAG, Zurich, Switzerland

DUT: Dipole 5GHz; Type: D5GHzV2; Serial: D5GHzV2 - SN: 1007

Communication System: UID 0 - CW ; Frequency: 5200 MHz, Frequency: 5300 MHz, Frequency: 5500 MHz, Frequency: 5600 MHz, Frequency: 5800 MHz

Medium parameters used: $f = 5200$ MHz; $\sigma = 5.36$ S/m; $\epsilon_r = 48.3$; $\rho = 1000$ kg/m³, Medium parameters used: $f = 5300$ MHz; $\sigma = 5.56$ S/m; $\epsilon_r = 48.1$; $\rho = 1000$ kg/m³, Medium parameters used: $f = 5500$ MHz; $\sigma = 5.75$ S/m; $\epsilon_r = 47.8$; $\rho = 1000$ kg/m³, Medium parameters used: $f = 5600$ MHz; $\sigma = 5.88$ S/m; $\epsilon_r = 47.6$; $\rho = 1000$ kg/m³, Medium parameters used: $f = 5800$ MHz; $\sigma = 6.17$ S/m; $\epsilon_r = 47.3$; $\rho = 1000$ kg/m³

Phantom section: Flat Section

Measurement Standard: DASY5 (IEEE/IEC/ANSI C63.19-2007)

DASY52 Configuration:

- Probe: EX3DV4 - SN3503; ConvF(4.91, 4.91, 4.91); Calibrated: 28.12.2012, ConvF(4.67, 4.67, 4.67); Calibrated: 28.12.2012, ConvF(4.43, 4.43, 4.43); Calibrated: 28.12.2012, ConvF(4.22, 4.22, 4.22); Calibrated: 28.12.2012, ConvF(4.38, 4.38, 4.38); Calibrated: 28.12.2012;
- Sensor-Surface: 1.4mm (Mechanical Surface Detection)
- Electronics: DAE4 Sn601; Calibrated: 25.04.2013
- Phantom: Flat Phantom 5.0 (back); Type: QD000P50AA; Serial: 1002
- DASY52 52.8.7(1137); SEMCAD X 14.6.10(7164)

Dipole Calibration for Body Tissue/Pin=100mW, dist=10mm, f=5200 MHz/Zoom Scan, dist=1.4mm (8x8x7)/Cube 0: Measurement grid: dx=4mm, dy=4mm, dz=1.4mm

Reference Value = 58.606 V/m; Power Drift = -0.02 dB

Peak SAR (extrapolated) = 28.6 W/kg

SAR(1 g) = 7.28 W/kg; SAR(10 g) = 2.03 W/kg

Maximum value of SAR (measured) = 17.2 W/kg

Dipole Calibration for Body Tissue/Pin=100mW, dist=10mm, f=5300 MHz/Zoom Scan, dist=1.4mm (8x8x7)/Cube 0: Measurement grid: dx=4mm, dy=4mm, dz=1.4mm

Reference Value = 58.305 V/m; Power Drift = 0.01 dB

Peak SAR (extrapolated) = 30.3 W/kg

SAR(1 g) = 7.49 W/kg; SAR(10 g) = 2.09 W/kg

Maximum value of SAR (measured) = 17.8 W/kg

Dipole Calibration for Body Tissue/Pin=100mW, dist=10mm, f=5500 MHz/Zoom Scan, dist=1.4mm (8x8x7)/Cube 0: Measurement grid: dx=4mm, dy=4mm, dz=1.4mm

Reference Value = 58.471 V/m; Power Drift = -0.00 dB

Peak SAR (extrapolated) = 32.4 W/kg

SAR(1 g) = 7.61 W/kg; SAR(10 g) = 2.11 W/kg

Maximum value of SAR (measured) = 18.5 W/kg

Dipole Calibration for Body Tissue/Pin=100mW, dist=10mm, f=5600 MHz/Zoom Scan, dist=1.4mm (8x8x7)/Cube 0: Measurement grid: dx=4mm, dy=4mm, dz=1.4mm

Reference Value = 58.333 V/m; Power Drift = -0.01 dB

Peak SAR (extrapolated) = 33.8 W/kg

SAR(1 g) = 7.75 W/kg; SAR(10 g) = 2.16 W/kg

Maximum value of SAR (measured) = 19.1 W/kg

Dipole Calibration for Body Tissue/Pin=100mW, dist=10mm, f=5800 MHz/Zoom Scan, dist=1.4mm (8x8x7)/Cube 0: Measurement grid: dx=4mm, dy=4mm, dz=1.4mm

Reference Value = 55.389 V/m; Power Drift = 0.00 dB

Peak SAR (extrapolated) = 34.1 W/kg

SAR(1 g) = 7.31 W/kg; SAR(10 g) = 2.02 W/kg

Maximum value of SAR (measured) = 18.3 W/kg

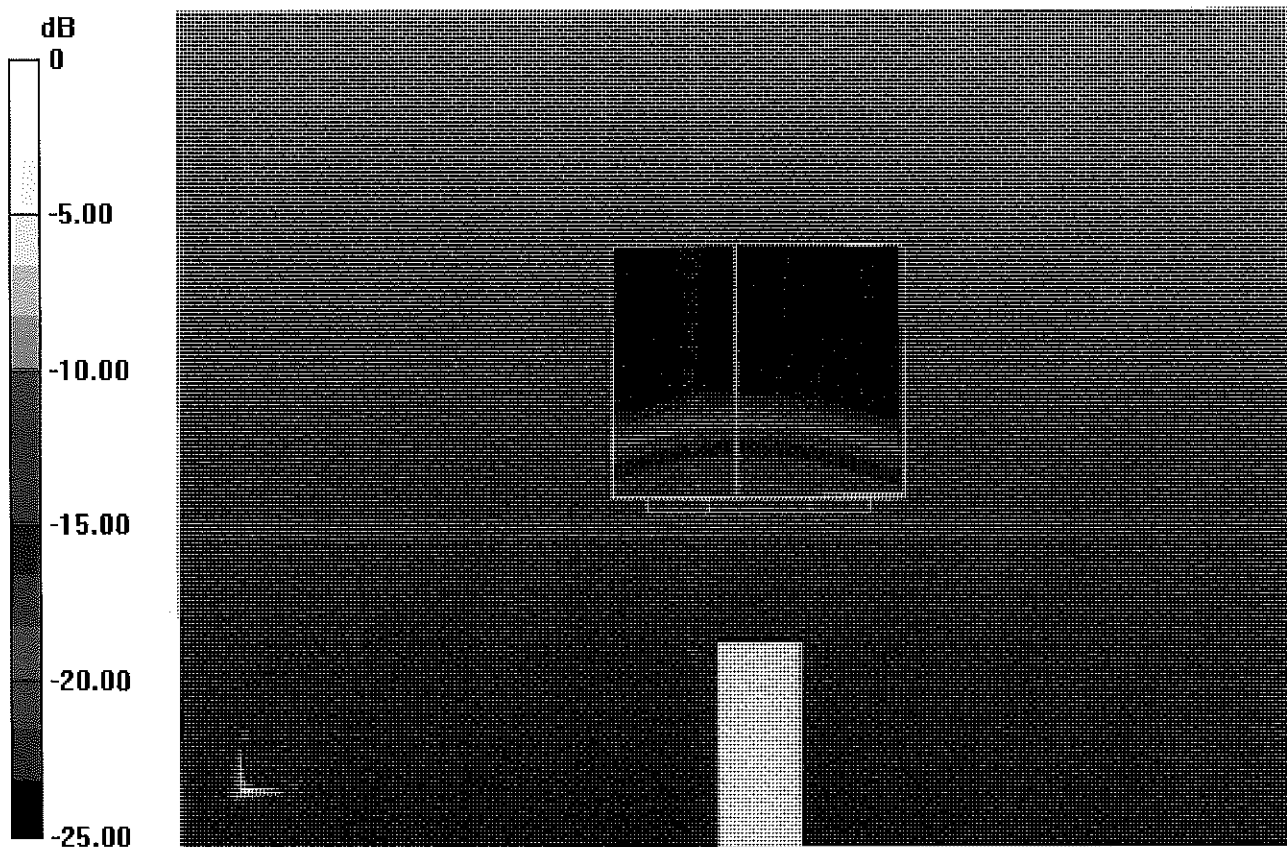

0 dB = 18.3 W/kg = 12.62 dBW/kg

Impedance Measurement Plot for Body TSL

19 Sep 2013 15:38:51

CH1 S11 1 U FS

1: 53.098 Ω -10.264 Ω 2.9820 μ F 5 200.000 000 MHz

*
De1
Cor
Avg
0
H1d

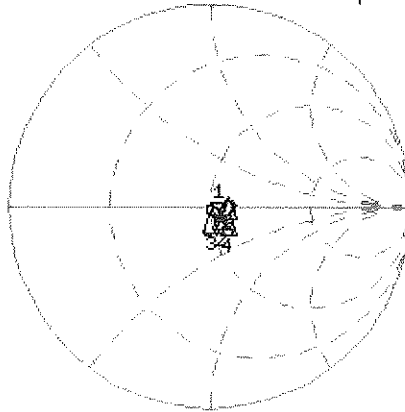

CH1 Markers

- 2: 54.285 Ω
-1.5293 Ω
5.30000 GHz
- 3: 49.717 Ω
-3.6367 Ω
5.50000 GHz
- 4: 58.225 Ω
-5.2344 Ω
5.60000 GHz
- 5: 58.725 Ω
3.9121 Ω
5.80000 GHz

CH2 S11 LOG 5 dB/REF -20 dB 1:-19.701 dB 5 200.000 000 MHz

Cor
Avg
0
H1d

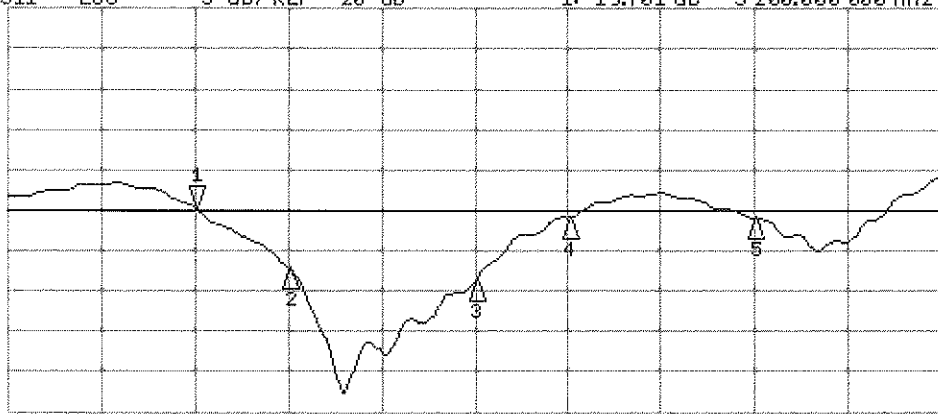

CH2 Markers

- 2: -27.201 dB
5.30000 GHz
- 3: -28.741 dB
5.50000 GHz
- 4: -20.917 dB
5.60000 GHz
- 5: -21.121 dB
5.80000 GHz

START 5 000.000 000 MHz

STOP 6 000.000 000 MHz



Accredited by the Swiss Accreditation Service (SAS)
The Swiss Accreditation Service is one of the signatories to the EA
Multilateral Agreement for the recognition of calibration certificates

Accreditation No.: **SCS 108**

Client **PC Test**

Certificate No: **D750V3-1003_Jan14**

CALIBRATION CERTIFICATE

Object **D750V3 - SN: 1003**

Calibration procedure(s) **QA CAL-05.v9
Calibration procedure for dipole validation kits above 700 MHz**

Calibration date: **January 20, 2014**

CC
21/14 ✓

This calibration certificate documents the traceability to national standards, which realize the physical units of measurements (SI).
The measurements and the uncertainties with confidence probability are given on the following pages and are part of the certificate.

All calibrations have been conducted in the closed laboratory facility: environment temperature $(22 \pm 3)^\circ\text{C}$ and humidity $< 70\%$.

Calibration Equipment used (M&TE critical for calibration)

Primary Standards	ID #	Cal Date (Certificate No.)	Scheduled Calibration
Power meter EPM-442A	GB37480704	09-Oct-13 (No. 217-01827)	Oct-14
Power sensor HP 8481A	US37292783	09-Oct-13 (No. 217-01827)	Oct-14
Power sensor HP 8481A	MY41092317	09-Oct-13 (No. 217-01828)	Oct-14
Reference 20 dB Attenuator	SN: 5058 (20k)	04-Apr-13 (No. 217-01736)	Apr-14
Type-N mismatch combination	SN: 5047.3 / 06327	04-Apr-13 (No. 217-01739)	Apr-14
Reference Probe ES3DV3	SN: 3205	30-Dec-13 (No. ES3-3205_Dec13)	Dec-14
DAE4	SN: 601	25-Apr-13 (No. DAE4-601_Apr13)	Apr-14
Secondary Standards	ID #	Check Date (in house)	Scheduled Check
RF generator R&S SMT-06	100005	04-Aug-99 (in house check Oct-13)	In house check: Oct-16
Network Analyzer HP 8753E	US37390585 S4206	18-Oct-01 (in house check Oct-13)	In house check: Oct-14

Calibrated by: **Israe El-Naouq** Laboratory Technician
Approved by: **Katja Pokovic** Technical Manager

Signature
Israe El-Naouq
Katja Pokovic

Issued: January 21, 2014

This calibration certificate shall not be reproduced except in full without written approval of the laboratory.



Accredited by the Swiss Accreditation Service (SAS)
The Swiss Accreditation Service is one of the signatories to the EA
Multilateral Agreement for the recognition of calibration certificates

Accreditation No.: **SCS 108**

Glossary:

TSL	tissue simulating liquid
ConvF	sensitivity in TSL / NORM x,y,z
N/A	not applicable or not measured

Calibration is Performed According to the Following Standards:

- a) IEEE Std 1528-2013, "IEEE Recommended Practice for Determining the Peak Spatial-Averaged Specific Absorption Rate (SAR) in the Human Head from Wireless Communications Devices: Measurement Techniques", June 2013
- b) IEC 62209-1, "Procedure to measure the Specific Absorption Rate (SAR) for hand-held devices used in close proximity to the ear (frequency range of 300 MHz to 3 GHz)", February 2005
- c) KDB 865664, "SAR Measurement Requirements for 100 MHz to 6 GHz"

Additional Documentation:

- d) DASY4/5 System Handbook

Methods Applied and Interpretation of Parameters:

- *Measurement Conditions:* Further details are available from the Validation Report at the end of the certificate. All figures stated in the certificate are valid at the frequency indicated.
- *Antenna Parameters with TSL:* The dipole is mounted with the spacer to position its feed point exactly below the center marking of the flat phantom section, with the arms oriented parallel to the body axis.
- *Feed Point Impedance and Return Loss:* These parameters are measured with the dipole positioned under the liquid filled phantom. The impedance stated is transformed from the measurement at the SMA connector to the feed point. The Return Loss ensures low reflected power. No uncertainty required.
- *Electrical Delay:* One-way delay between the SMA connector and the antenna feed point. No uncertainty required.
- *SAR measured:* SAR measured at the stated antenna input power.
- *SAR normalized:* SAR as measured, normalized to an input power of 1 W at the antenna connector.
- *SAR for nominal TSL parameters:* The measured TSL parameters are used to calculate the nominal SAR result.

The reported uncertainty of measurement is stated as the standard uncertainty of measurement multiplied by the coverage factor $k=2$, which for a normal distribution corresponds to a coverage probability of approximately 95%.

Measurement Conditions

DASY system configuration, as far as not given on page 1.

DASY Version	DASY5	V52.8.7
Extrapolation	Advanced Extrapolation	
Phantom	Modular Flat Phantom	
Distance Dipole Center - TSL	15 mm	with Spacer
Zoom Scan Resolution	dx, dy, dz = 5 mm	
Frequency	750 MHz \pm 1 MHz	

Head TSL parameters

The following parameters and calculations were applied.

	Temperature	Permittivity	Conductivity
Nominal Head TSL parameters	22.0 °C	41.9	0.89 mho/m
Measured Head TSL parameters	(22.0 \pm 0.2) °C	40.8 \pm 6 %	0.92 mho/m \pm 6 %
Head TSL temperature change during test	< 0.5 °C	----	----

SAR result with Head TSL

SAR averaged over 1 cm³ (1 g) of Head TSL	Condition	
SAR measured	250 mW input power	2.16 W/kg
SAR for nominal Head TSL parameters	normalized to 1W	8.37 W/kg \pm 17.0 % (k=2)

SAR averaged over 10 cm³ (10 g) of Head TSL	condition	
SAR measured	250 mW input power	1.40 W/kg
SAR for nominal Head TSL parameters	normalized to 1W	5.46 W/kg \pm 16.5 % (k=2)

Body TSL parameters

The following parameters and calculations were applied.

	Temperature	Permittivity	Conductivity
Nominal Body TSL parameters	22.0 °C	55.5	0.96 mho/m
Measured Body TSL parameters	(22.0 \pm 0.2) °C	54.0 \pm 6 %	0.98 mho/m \pm 6 %
Body TSL temperature change during test	< 0.5 °C	----	----

SAR result with Body TSL

SAR averaged over 1 cm³ (1 g) of Body TSL	Condition	
SAR measured	250 mW input power	2.24 W/kg
SAR for nominal Body TSL parameters	normalized to 1W	8.77 W/kg \pm 17.0 % (k=2)

SAR averaged over 10 cm³ (10 g) of Body TSL	condition	
SAR measured	250 mW input power	1.47 W/kg
SAR for nominal Body TSL parameters	normalized to 1W	5.78 W/kg \pm 16.5 % (k=2)

Appendix

Antenna Parameters with Head TSL

Impedance, transformed to feed point	54.7 Ω - 0.2 j Ω
Return Loss	- 27.0 dB

Antenna Parameters with Body TSL

Impedance, transformed to feed point	49.5 Ω - 2.6 j Ω
Return Loss	- 31.4 dB

General Antenna Parameters and Design

Electrical Delay (one direction)	1.043 ns
----------------------------------	----------

After long term use with 100W radiated power, only a slight warming of the dipole near the feedpoint can be measured.

The dipole is made of standard semirigid coaxial cable. The center conductor of the feeding line is directly connected to the second arm of the dipole. The antenna is therefore short-circuited for DC-signals. On some of the dipoles, small end caps are added to the dipole arms in order to improve matching when loaded according to the position as explained in the "Measurement Conditions" paragraph. The SAR data are not affected by this change. The overall dipole length is still according to the Standard.

No excessive force must be applied to the dipole arms, because they might bend or the soldered connections near the feedpoint may be damaged.

Additional EUT Data

Manufactured by	SPEAG
Manufactured on	January 21, 2009

DASY5 Validation Report for Head TSL

Date: 20.01.2014

Test Laboratory: SPEAG, Zurich, Switzerland

DUT: Dipole 750 MHz; Type: D750V3; Serial: D750V3 - SN: 1003

Communication System: UID 0 - CW; Frequency: 750 MHz

Medium parameters used: $f = 750$ MHz; $\sigma = 0.92$ S/m; $\epsilon_r = 40.8$; $\rho = 1000$ kg/m³

Phantom section: Flat Section

Measurement Standard: DASY5 (IEEE/IEC/ANSI C63.19-2007)

DASY52 Configuration:

- Probe: ES3DV3 - SN3205; ConvF(6.37, 6.37, 6.37); Calibrated: 30.12.2013;
- Sensor-Surface: 3mm (Mechanical Surface Detection)
- Electronics: DAE4 Sn601; Calibrated: 25.04.2013
- Phantom: Flat Phantom 4.9L; Type: QD000P49AA; Serial: 1001
- DASY52 52.8.7(1137); SEMCAD X 14.6.10(7164)

Dipole Calibration for Head Tissue/Pin=250 mW, d=15mm/Zoom Scan (7x7x7)/Cube 0:

Measurement grid: dx=5mm, dy=5mm, dz=5mm

Reference Value = 53.711 V/m; Power Drift = 0.02 dB

Peak SAR (extrapolated) = 3.27 W/kg

SAR(1 g) = 2.16 W/kg; SAR(10 g) = 1.4 W/kg

Maximum value of SAR (measured) = 2.51 W/kg

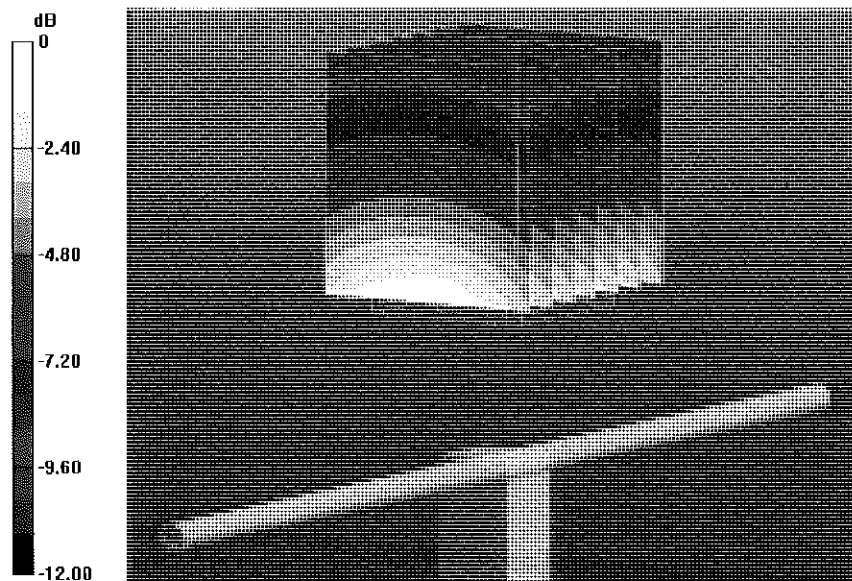

0 dB = 2.51 W/kg = 4.00 dBW/kg

Impedance Measurement Plot for Head TSL

20 Jan 2014 16:36:06

CH1 S11 1 U FS

1: 54.678 Ω -156.25 m \angle 1.3581 nF

750.000 000 MHz

*
De1

C Δ

Avg
16

H1d

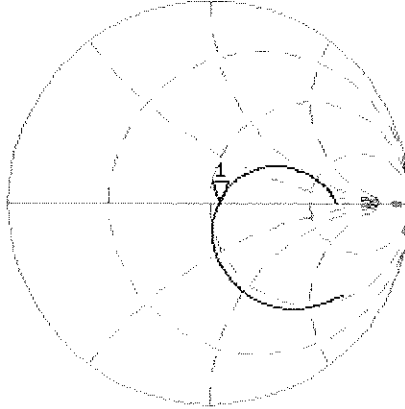

CH2 S11 LOG

5 dB/REF -20 dB

1: -26.992 dB

750.000 000 MHz

C Δ

Avg
16

H1d

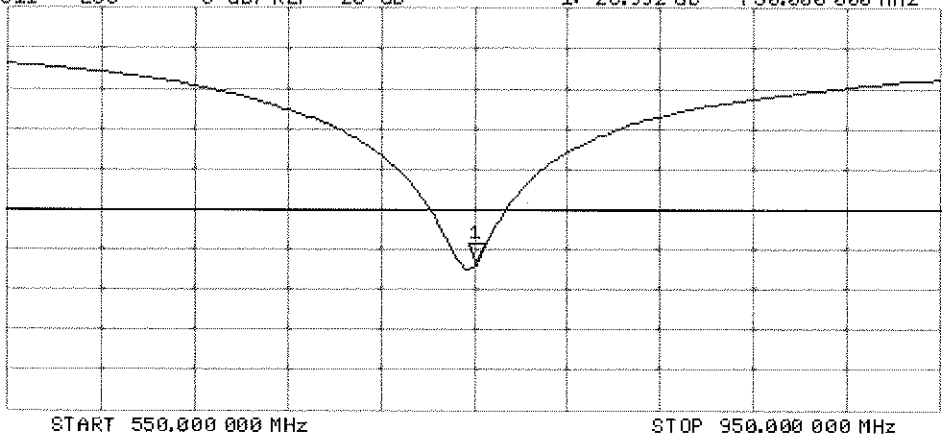

DASY5 Validation Report for Body TSL

Date: 20.01.2014

Test Laboratory: SPEAG, Zurich, Switzerland

DUT: Dipole 750 MHz; Type: D750V3; Serial: D750V3 - SN: 1003

Communication System: UID 0 - CW; Frequency: 750 MHz

Medium parameters used: $f = 750$ MHz; $\sigma = 0.98$ S/m; $\epsilon_r = 54$; $\rho = 1000$ kg/m³

Phantom section: Flat Section

Measurement Standard: DASY5 (IEEE/IEC/ANSI C63.19-2007)

DASY52 Configuration:

- Probe: ES3DV3 - SN3205; ConvF(6.13, 6.13, 6.13); Calibrated: 30.12.2013;
- Sensor-Surface: 3mm (Mechanical Surface Detection)
- Electronics: DAE4 Sn601; Calibrated: 25.04.2013
- Phantom: Flat Phantom 4.9L; Type: QD000P49AA; Serial: 1001
- DASY52 52.8.7(1137); SEMCAD X 14.6.10(7164)

Dipole Calibration for Body Tissue/Pin=250 mW, d=15mm/Zoom Scan (7x7x7)/Cube 0:

Measurement grid: dx=5mm, dy=5mm, dz=5mm

Reference Value = 53.082 V/m; Power Drift = 0.03 dB

Peak SAR (extrapolated) = 3.31 W/kg

SAR(1 g) = 2.24 W/kg; SAR(10 g) = 1.47 W/kg

Maximum value of SAR (measured) = 2.58 W/kg

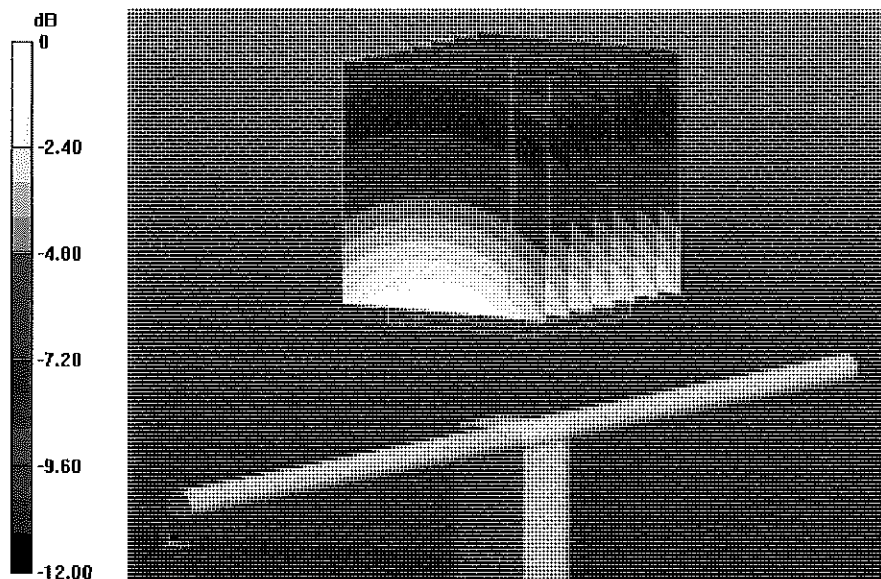

0 dB = 2.58 W/kg = 4.12 dBW/kg

Impedance Measurement Plot for Body TSL

20 Jan 2014 10:20:18
[CH1] S11 1 U FS 1: 49.459 Ω -2.6367 Ω 80.481 pF 750.000 000 MHz

*
De1

CA

Avg
16

H1d

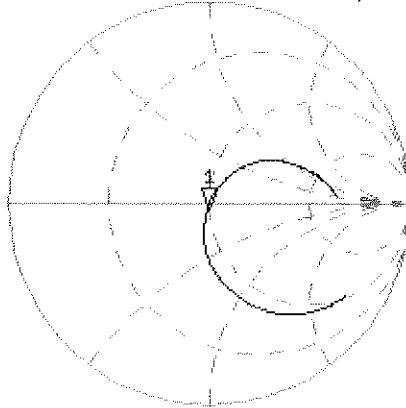

CH2 S11 LOG 5 dB/REF -20 dB 1: -31.359 dB 750.000 000 MHz

CA

Avg
16

H1d

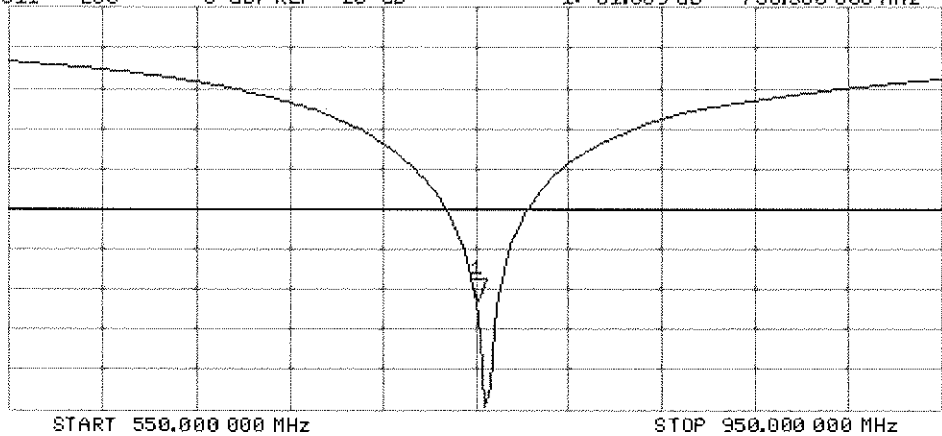



Accredited by the Swiss Accreditation Service (SAS)
The Swiss Accreditation Service is one of the signatories to the EA
Multilateral Agreement for the recognition of calibration certificates

Accreditation No.: **SCS 108**

Client **PC Test**

Certificate No: **ES3-3258_Feb14**

CALIBRATION CERTIFICATE

Object **ES3DV3 - SN:3258**

Calibration procedure(s) **QA CAL-01.v9, QA CAL-23.v5, QA CAL-25.v6
Calibration procedure for dosimetric E-field probes** *CCV
3/16/14*

Calibration date: **February 25, 2014**

This calibration certificate documents the traceability to national standards, which realize the physical units of measurements (SI).
The measurements and the uncertainties with confidence probability are given on the following pages and are part of the certificate.

All calibrations have been conducted in the closed laboratory facility: environment temperature (22 ± 3)°C and humidity < 70%.

Calibration Equipment used (M&TE critical for calibration)

Primary Standards	ID	Cal Date (Certificate No.)	Scheduled Calibration
Power meter E4419B	GB41293874	04-Apr-13 (No. 217-01733)	Apr-14
Power sensor E4412A	MY41498087	04-Apr-13 (No. 217-01733)	Apr-14
Reference 3 dB Attenuator	SN: S5054 (3c)	04-Apr-13 (No. 217-01737)	Apr-14
Reference 20 dB Attenuator	SN: S5277 (20x)	04-Apr-13 (No. 217-01735)	Apr-14
Reference 30 dB Attenuator	SN: S5129 (30b)	04-Apr-13 (No. 217-01738)	Apr-14
Reference Probe ES3DV2	SN: 3013	30-Dec-13 (No. ES3-3013_Dec13)	Dec-14
DAE4	SN: 660	13-Dec-13 (No. DAE4-660_Dec13)	Dec-14
Secondary Standards	ID	Check Date (in house)	Scheduled Check
RF generator HP 8648C	US3642U01700	4-Aug-99 (in house check Apr-13)	In house check: Apr-16
Network Analyzer HP 8753E	US37390585	18-Oct-01 (in house check Oct-13)	In house check: Oct-14

Calibrated by:	Name Israe El-Naouq	Function Laboratory Technician	Signature <i>Israe El-Naouq</i>
Approved by:	Katja Pokovic	Technical Manager	<i>Katja Pokovic</i>

Issued: February 27, 2014

This calibration certificate shall not be reproduced except in full without written approval of the laboratory.

PCT# 80615



Accredited by the Swiss Accreditation Service (SAS)

Accreditation No.: **SCS 108**

The Swiss Accreditation Service is one of the signatories to the EA Multilateral Agreement for the recognition of calibration certificates

Glossary:

TSL	tissue simulating liquid
NORM _{x,y,z}	sensitivity in free space
ConvF	sensitivity in TSL / NORM _{x,y,z}
DCP	diode compression point
CF	crest factor (1/duty_cycle) of the RF signal
A, B, C, D	modulation dependent linearization parameters
Polarization φ	φ rotation around probe axis
Polarization ϑ	ϑ rotation around an axis that is in the plane normal to probe axis (at measurement center), i.e., $\vartheta = 0$ is normal to probe axis
Connector Angle	information used in DASY system to align probe sensor X to the robot coordinate system

Calibration is Performed According to the Following Standards:

- a) IEEE Std 1528-2013, "IEEE Recommended Practice for Determining the Peak Spatial-Averaged Specific Absorption Rate (SAR) in the Human Head from Wireless Communications Devices: Measurement Techniques", June 2013
- b) IEC 62209-1, "Procedure to measure the Specific Absorption Rate (SAR) for hand-held devices used in close proximity to the ear (frequency range of 300 MHz to 3 GHz)", February 2005

Methods Applied and Interpretation of Parameters:

- *NORM_{x,y,z}*: Assessed for E-field polarization $\vartheta = 0$ ($f \leq 900$ MHz in TEM-cell; $f > 1800$ MHz: R22 waveguide). *NORM_{x,y,z}* are only intermediate values, i.e., the uncertainties of *NORM_{x,y,z}* does not affect the E^2 -field uncertainty inside TSL (see below *ConvF*).
- *NORM(f)_{x,y,z}* = *NORM_{x,y,z}* * *frequency_response* (see Frequency Response Chart). This linearization is implemented in DASY4 software versions later than 4.2. The uncertainty of the frequency response is included in the stated uncertainty of *ConvF*.
- *DCP_{x,y,z}*: DCP are numerical linearization parameters assessed based on the data of power sweep with CW signal (no uncertainty required). DCP does not depend on frequency nor media.
- *PAR*: PAR is the Peak to Average Ratio that is not calibrated but determined based on the signal characteristics
- *A_{x,y,z}*; *B_{x,y,z}*; *C_{x,y,z}*; *D_{x,y,z}*; *VR_{x,y,z}*: *A, B, C, D* are numerical linearization parameters assessed based on the data of power sweep for specific modulation signal. The parameters do not depend on frequency nor media. *VR* is the maximum calibration range expressed in RMS voltage across the diode.
- *ConvF and Boundary Effect Parameters*: Assessed in flat phantom using E-field (or Temperature Transfer Standard for $f \leq 800$ MHz) and inside waveguide using analytical field distributions based on power measurements for $f > 800$ MHz. The same setups are used for assessment of the parameters applied for boundary compensation (alpha, depth) of which typical uncertainty values are given. These parameters are used in DASY4 software to improve probe accuracy close to the boundary. The sensitivity in TSL corresponds to *NORM_{x,y,z}* * *ConvF* whereby the uncertainty corresponds to that given for *ConvF*. A frequency dependent *ConvF* is used in DASY version 4.4 and higher which allows extending the validity from ± 50 MHz to ± 100 MHz.
- *Spherical isotropy (3D deviation from isotropy)*: in a field of low gradients realized using a flat phantom exposed by a patch antenna.
- *Sensor Offset*: The sensor offset corresponds to the offset of virtual measurement center from the probe tip (on probe axis). No tolerance required.
- *Connector Angle*: The angle is assessed using the information gained by determining the *NORM_x* (no uncertainty required).

Probe ES3DV3

SN:3258

Manufactured: January 25, 2010
Calibrated: February 25, 2014

Calibrated for DASY/EASY Systems
(Note: non-compatible with DASY2 system!)

DASY/EASY - Parameters of Probe: ES3DV3 - SN:3258

Basic Calibration Parameters

	Sensor X	Sensor Y	Sensor Z	Unc (k=2)
Norm ($\mu V/(V/m)^2$) ^A	1.29	1.19	1.23	± 10.1 %
DCP (mV) ^B	104.5	107.0	103.0	

Modulation Calibration Parameters

UID	Communication System Name		A dB	B dB√μV	C	D dB	VR mV	Unc ^E (k=2)
0	CW	X	0.0	0.0	1.0	0.00	222.4	±3.8 %
		Y	0.0	0.0	1.0		202.2	
		Z	0.0	0.0	1.0		207.1	
10010-CAA	SAR Validation (Square, 100ms, 10ms)	X	5.09	65.6	14.1	10.00	44.8	±1.9 %
		Y	1.68	57.4	9.3		40.7	
		Z	4.01	62.4	13.0		51.1	
10011-CAB	UMTS-FDD (WCDMA)	X	3.34	67.5	18.9	2.91	131.2	±0.5 %
		Y	3.43	67.9	18.7		137.1	
		Z	3.42	67.8	19.0		146.0	
10012-CAA	IEEE 802.11b WiFi 2.4 GHz (DSSS, 1 Mbps)	X	3.40	70.9	19.8	1.87	134.2	±0.7 %
		Y	3.19	70.2	19.2		137.9	
		Z	3.46	70.8	19.6		149.6	
10021-DAB	GSM-FDD (TDMA, GMSK)	X	30.24	99.7	28.7	9.39	131.2	±1.4 %
		Y	12.91	88.5	23.9		147.5	
		Z	30.37	99.5	28.9		128.0	
10023-DAB	GPRS-FDD (TDMA, GMSK, TN 0)	X	29.88	100.0	29.0	9.57	123.0	±1.9 %
		Y	16.02	92.5	25.4		140.7	
		Z	30.01	100.0	29.4		125.8	
10024-DAB	GPRS-FDD (TDMA, GMSK, TN 0-1)	X	44.57	99.7	25.9	6.56	119.6	±1.7 %
		Y	28.97	95.3	23.2		127.6	
		Z	43.72	99.8	26.3		120.1	
10027-DAB	GPRS-FDD (TDMA, GMSK, TN 0-1-2)	X	53.52	99.7	24.4	4.80	129.4	±2.2 %
		Y	54.55	99.9	22.9		143.3	
		Z	51.63	99.7	24.8		127.5	
10028-DAB	GPRS-FDD (TDMA, GMSK, TN 0-1-2-3)	X	58.93	99.8	23.4	3.55	133.4	±2.2 %
		Y	77.54	99.7	21.3		125.3	
		Z	56.64	99.8	23.8		130.8	
10032-CAA	IEEE 802.15.1 Bluetooth (GFSK, DH5)	X	47.03	99.5	21.3	1.16	136.3	±1.7 %
		Y	95.86	95.2	17.1		138.2	
		Z	39.68	100.0	22.2		132.3	
10039-CAB	CDMA2000 (1xRTT, RC1)	X	4.84	66.8	19.1	4.57	131.3	±0.9 %
		Y	4.75	67.0	18.9		135.2	
		Z	4.86	66.7	19.0		127.2	

10081-CAB	CDMA2000 (1xRTT, RC3)	X	4.06	66.8	19.0	3.97	148.4	±0.7 %
		Y	3.96	66.6	18.6		134.7	
		Z	4.13	66.9	19.1		143.4	
10098-CAB	UMTS-FDD (HSUPA, Subtest 2)	X	4.63	66.8	18.7	3.98	137.3	±0.7 %
		Y	4.75	67.5	18.8		148.4	
		Z	4.65	66.7	18.7		133.2	
10100-CAB	LTE-FDD (SC-FDMA, 100% RB, 20 MHz, QPSK)	X	6.66	68.5	20.3	5.67	144.0	±1.2 %
		Y	6.27	67.1	19.3		130.6	
		Z	6.62	68.2	20.1		140.5	
10108-CAB	LTE-FDD (SC-FDMA, 100% RB, 10 MHz, QPSK)	X	6.53	68.0	20.2	5.80	142.6	±1.4 %
		Y	6.17	66.8	19.3		129.2	
		Z	6.52	67.8	20.1		139.0	
10110-CAB	LTE-FDD (SC-FDMA, 100% RB, 5 MHz, QPSK)	X	6.19	67.3	19.9	5.75	137.9	±1.4 %
		Y	6.12	67.3	19.6		149.5	
		Z	6.19	67.1	19.8		136.1	
10114-CAA	IEEE 802.11n (HT Greenfield, 13.5 Mbps, BPSK)	X	10.49	69.5	21.7	8.10	132.4	±2.5 %
		Y	10.23	69.1	21.3		144.3	
		Z	10.45	69.3	21.6		129.5	
10117-CAA	IEEE 802.11n (HT Mixed, 13.5 Mbps, BPSK)	X	10.46	69.5	21.7	8.07	133.9	±2.5 %
		Y	10.26	69.2	21.3		147.4	
		Z	10.47	69.4	21.7		130.5	
10151-CAB	LTE-TDD (SC-FDMA, 50% RB, 20 MHz, QPSK)	X	11.61	77.4	26.8	9.28	118.8	±3.0 %
		Y	9.89	75.2	25.7		144.9	
		Z	12.01	77.8	26.9		119.6	
10154-CAB	LTE-FDD (SC-FDMA, 50% RB, 10 MHz, QPSK)	X	6.20	67.3	19.9	5.75	139.2	±1.2 %
		Y	5.86	66.2	19.0		128.5	
		Z	6.22	67.3	19.9		136.3	
10160-CAB	LTE-FDD (SC-FDMA, 50% RB, 15 MHz, QPSK)	X	6.63	67.8	20.1	5.82	144.1	±1.4 %
		Y	6.31	66.8	19.3		133.1	
		Z	6.66	67.7	20.0		140.9	
10169-CAB	LTE-FDD (SC-FDMA, 1 RB, 20 MHz, QPSK)	X	5.25	67.5	20.2	5.73	143.6	±1.2 %
		Y	4.92	66.7	19.5		131.0	
		Z	5.29	67.4	20.2		140.7	
10172-CAB	LTE-TDD (SC-FDMA, 1 RB, 20 MHz, QPSK)	X	13.49	87.5	31.6	9.21	139.0	±2.7 %
		Y	7.83	75.5	26.0		124.9	
		Z	13.47	86.5	31.1		137.8	
10175-CAB	LTE-FDD (SC-FDMA, 1 RB, 10 MHz, QPSK)	X	5.22	67.4	20.1	5.72	144.3	±1.4 %
		Y	5.08	67.5	19.9		147.9	
		Z	5.26	67.2	20.0		139.6	
10181-CAB	LTE-FDD (SC-FDMA, 1 RB, 15 MHz, QPSK)	X	5.24	67.5	20.1	5.72	144.5	±1.2 %
		Y	5.06	67.4	19.8		147.0	
		Z	5.29	67.3	20.1		139.2	

10193-CAA	IEEE 802.11n (HT Greenfield, 6.5 Mbps, BPSK)	X	10.12	69.1	21.6	8.09	128.8	±2.2 %
		Y	9.76	68.4	21.0		132.8	
		Z	10.08	68.9	21.5		123.4	
10196-CAA	IEEE 802.11n (HT Mixed, 6.5 Mbps, BPSK)	X	10.15	69.2	21.7	8.10	130.2	±2.2 %
		Y	9.77	68.5	21.0		134.1	
		Z	10.10	69.0	21.5		124.0	
10219-CAA	IEEE 802.11n (HT Mixed, 7.2 Mbps, BPSK)	X	10.02	69.0	21.5	8.03	128.7	±2.2 %
		Y	9.67	68.5	21.0		133.3	
		Z	10.02	68.9	21.5		123.9	
10222-CAA	IEEE 802.11n (HT Mixed, 15 Mbps, BPSK)	X	10.46	69.6	21.7	8.06	134.0	±2.2 %
		Y	10.09	68.8	21.1		139.7	
		Z	10.40	69.3	21.6		128.7	
10225-CAB	UMTS-FDD (HSPA+)	X	7.09	67.1	19.6	5.97	131.2	±1.4 %
		Y	6.98	67.2	19.4		138.0	
		Z	7.06	66.8	19.4		127.2	
10237-CAB	LTE-TDD (SC-FDMA, 1 RB, 10 MHz, QPSK)	X	13.63	87.8	31.7	9.21	141.6	±3.0 %
		Y	7.85	75.5	26.0		126.5	
		Z	13.99	87.7	31.6		141.4	
10252-CAB	LTE-TDD (SC-FDMA, 50% RB, 10 MHz, QPSK)	X	12.86	81.4	28.9	9.24	142.1	±3.0 %
		Y	8.91	73.4	24.8		129.9	
		Z	13.15	81.4	28.8		142.0	
10267-CAB	LTE-TDD (SC-FDMA, 100% RB, 10 MHz, QPSK)	X	11.63	77.5	26.8	9.30	118.7	±3.0 %
		Y	9.62	74.3	25.2		138.4	
		Z	11.96	77.7	26.9		119.3	
10274-CAB	UMTS-FDD (HSUPA, Subtest 5, 3GPP Rel8.10)	X	6.14	67.4	19.3	4.87	149.9	±0.9 %
		Y	5.90	66.9	18.7		132.8	
		Z	6.20	67.5	19.3		146.6	
10275-CAB	UMTS-FDD (HSUPA, Subtest 5, 3GPP Rel8.4)	X	4.45	66.9	18.9	3.96	130.1	±0.7 %
		Y	4.50	67.2	18.8		137.9	
		Z	4.64	67.6	19.3		149.2	
10291-AAB	CDMA2000, RC3, SO55, Full Rate	X	3.79	67.5	19.2	3.46	145.3	±0.7 %
		Y	3.74	67.5	18.9		128.2	
		Z	3.78	67.3	19.1		139.1	
10292-AAB	CDMA2000, RC3, SO32, Full Rate	X	3.77	67.8	19.3	3.39	147.0	±0.5 %
		Y	3.69	67.7	18.9		130.1	
		Z	3.73	67.3	19.0		141.3	
10297-AAA	LTE-FDD (SC-FDMA, 50% RB, 20 MHz, QPSK)	X	6.52	67.9	20.1	5.81	141.4	±1.4 %
		Y	6.41	67.6	19.7		147.4	
		Z	6.51	67.7	20.1		135.4	
10311-AAA	LTE-FDD (SC-FDMA, 100% RB, 15 MHz, QPSK)	X	7.17	68.7	20.7	6.06	147.7	±1.4 %
		Y	6.69	67.2	19.6		128.6	
		Z	7.12	68.4	20.5		142.0	

10315-AAA	IEEE 802.11b WiFi 2.4 GHz (DSSS, 1 Mbps, 96pc duty cycle)	X	3.04	70.0	19.6	1.71	129.8	±0.5 %
		Y	3.25	71.3	19.7		136.9	
		Z	3.09	69.9	19.5		148.7	
10403-AAB	CDMA2000 (1xEV-DO, Rev. 0)	X	4.73	67.3	18.6	3.76	135.7	±0.5 %
		Y	4.93	69.1	19.0		141.5	
		Z	4.73	67.1	18.4		132.7	
10404-AAB	CDMA2000 (1xEV-DO, Rev. A)	X	4.67	67.5	18.6	3.77	134.0	±0.5 %
		Y	4.92	69.4	19.1		139.8	
		Z	4.65	67.1	18.5		130.7	

The reported uncertainty of measurement is stated as the standard uncertainty of measurement multiplied by the coverage factor k=2, which for a normal distribution corresponds to a coverage probability of approximately 95%.

^A The uncertainties of NormX,Y,Z do not affect the E²-field uncertainty inside TSL (see Pages 8 and 9).
^B Numerical linearization parameter: uncertainty not required.
^E Uncertainty is determined using the max. deviation from linear response applying rectangular distribution and is expressed for the square of the field value.

DASY/EASY - Parameters of Probe: ES3DV3 - SN:3258

Calibration Parameter Determined in Head Tissue Simulating Media

f (MHz) ^C	Relative Permittivity ^F	Conductivity (S/m) ^F	ConvF X	ConvF Y	ConvF Z	Alpha ^G	Depth ^G (mm)	Unct. (k=2)
750	41.9	0.89	6.53	6.53	6.53	0.40	1.60	± 12.0 %
835	41.5	0.90	6.27	6.27	6.27	0.80	1.17	± 12.0 %
1750	40.1	1.37	5.19	5.19	5.19	0.80	1.10	± 12.0 %
1900	40.0	1.40	5.04	5.04	5.04	0.68	1.27	± 12.0 %
2450	39.2	1.80	4.52	4.52	4.52	0.78	1.23	± 12.0 %
2600	39.0	1.96	4.34	4.34	4.34	0.76	1.33	± 12.0 %

^C Frequency validity of ± 100 MHz only applies for DASY v4.4 and higher (see Page 2), else it is restricted to ± 50 MHz. The uncertainty is the RSS of the ConvF uncertainty at calibration frequency and the uncertainty for the indicated frequency band.

^F At frequencies below 3 GHz, the validity of tissue parameters (ϵ and σ) can be relaxed to ± 10% if liquid compensation formula is applied to measured SAR values. At frequencies above 3 GHz, the validity of tissue parameters (ϵ and σ) is restricted to ± 5%. The uncertainty is the RSS of the ConvF uncertainty for indicated target tissue parameters.

^G Alpha/Depth are determined during calibration. SPEAG warrants that the remaining deviation due to the boundary effect after compensation is always less than ± 1% for frequencies below 3 GHz and below ± 2% for frequencies between 3-6 GHz at any distance larger than half the probe tip diameter from the boundary.

DASY/EASY - Parameters of Probe: ES3DV3 - SN:3258

Calibration Parameter Determined in Body Tissue Simulating Media

f (MHz) ^C	Relative Permittivity ^F	Conductivity (S/m) ^F	ConvF X	ConvF Y	ConvF Z	Alpha ^G	Depth ^G (mm)	Unct. (k=2)
750	55.5	0.96	6.15	6.15	6.15	0.61	1.32	± 12.0 %
835	55.2	0.97	6.11	6.11	6.11	0.80	1.15	± 12.0 %
1750	53.4	1.49	4.83	4.83	4.83	0.47	1.74	± 12.0 %
1900	53.3	1.52	4.61	4.61	4.61	0.55	1.59	± 12.0 %
2450	52.7	1.95	4.14	4.14	4.14	0.80	1.11	± 12.0 %
2600	52.5	2.16	3.91	3.91	3.91	0.80	1.00	± 12.0 %

^C Frequency validity of ± 100 MHz only applies for DASY v4.4 and higher (see Page 2), else it is restricted to ± 50 MHz. The uncertainty is the RSS of the ConvF uncertainty at calibration frequency and the uncertainty for the indicated frequency band.

^F At frequencies below 3 GHz, the validity of tissue parameters (ϵ and σ) can be relaxed to ± 10% if liquid compensation formula is applied to measured SAR values. At frequencies above 3 GHz, the validity of tissue parameters (ϵ and σ) is restricted to ± 5%. The uncertainty is the RSS of the ConvF uncertainty for indicated target tissue parameters.

^G Alpha/Depth are determined during calibration. SPEAG warrants that the remaining deviation due to the boundary effect after compensation is always less than ± 1% for frequencies below 3 GHz and below ± 2% for frequencies between 3-6 GHz at any distance larger than half the probe tip diameter from the boundary.

Frequency Response of E-Field (TEM-Cell: ifi110 EXX, Waveguide: R22)

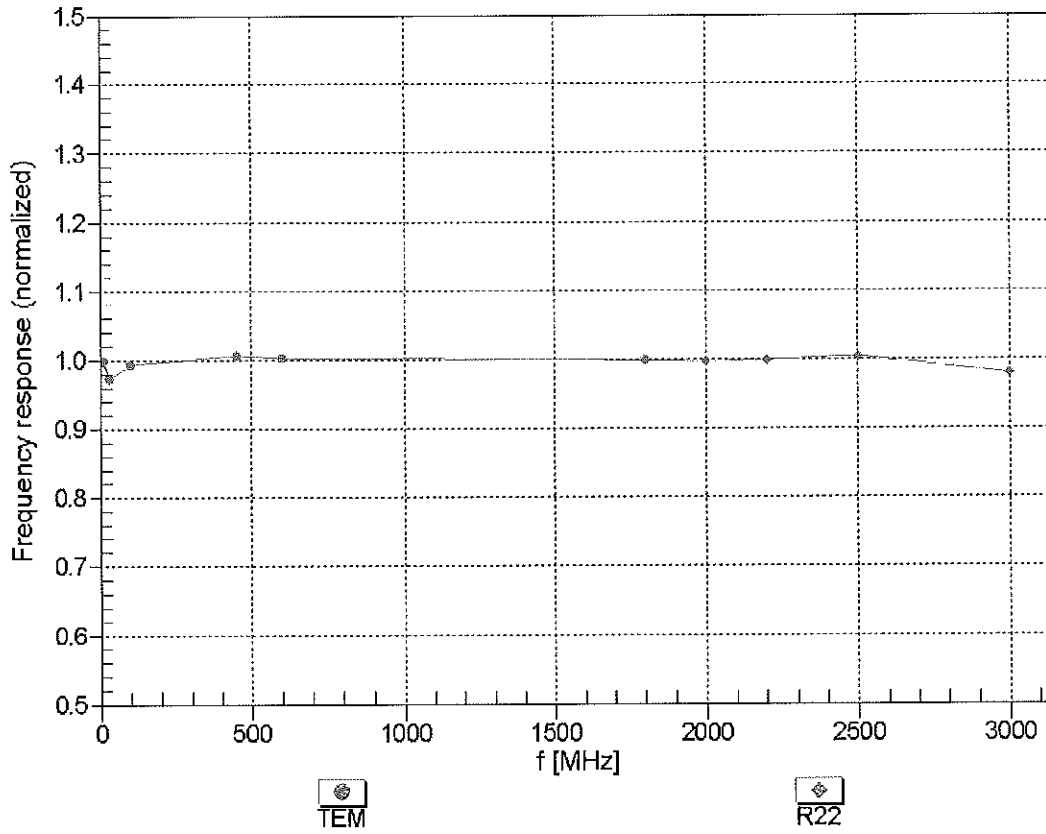

Uncertainty of Frequency Response of E-field: $\pm 6.3\%$ (k=2)

Receiving Pattern (ϕ), $\theta = 0^\circ$

f=600 MHz,TEM

f=1800 MHz,R22

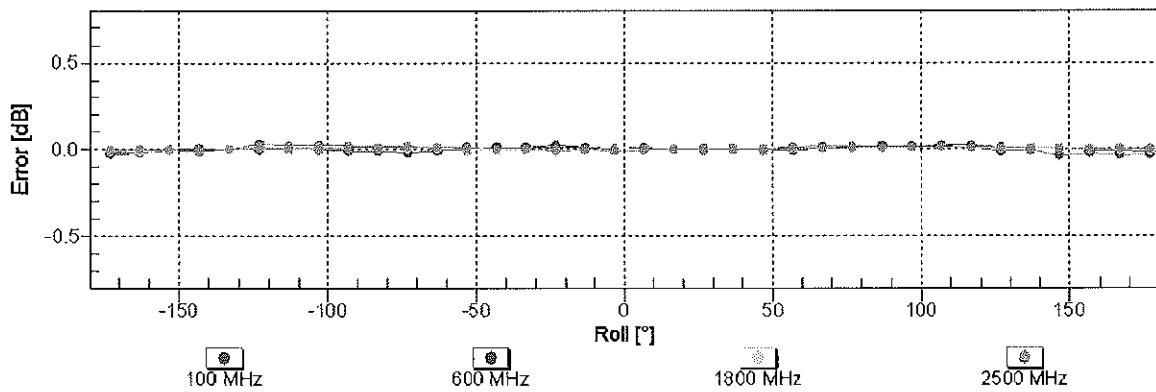
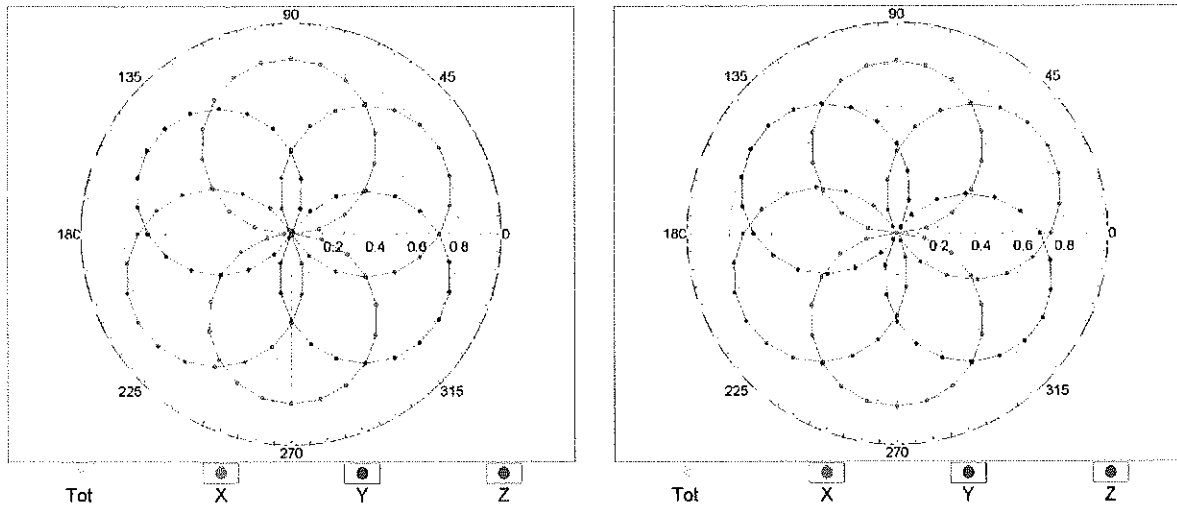

Uncertainty of Axial Isotropy Assessment: $\pm 0.5\%$ ($k=2$)

Dynamic Range f(SAR_{head}) (TEM cell , f_{eval}= 1900 MHz)

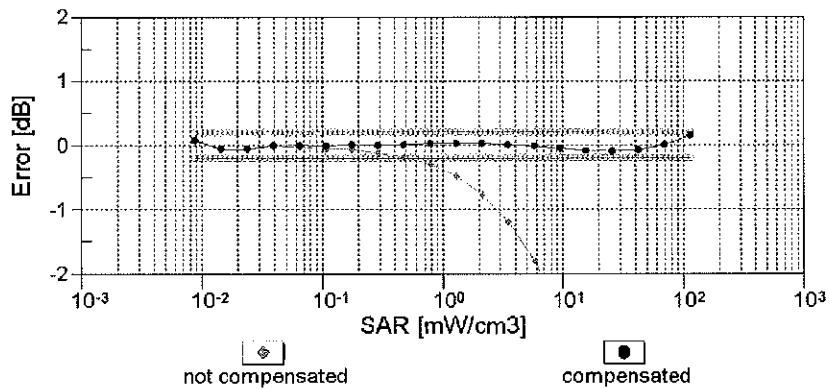
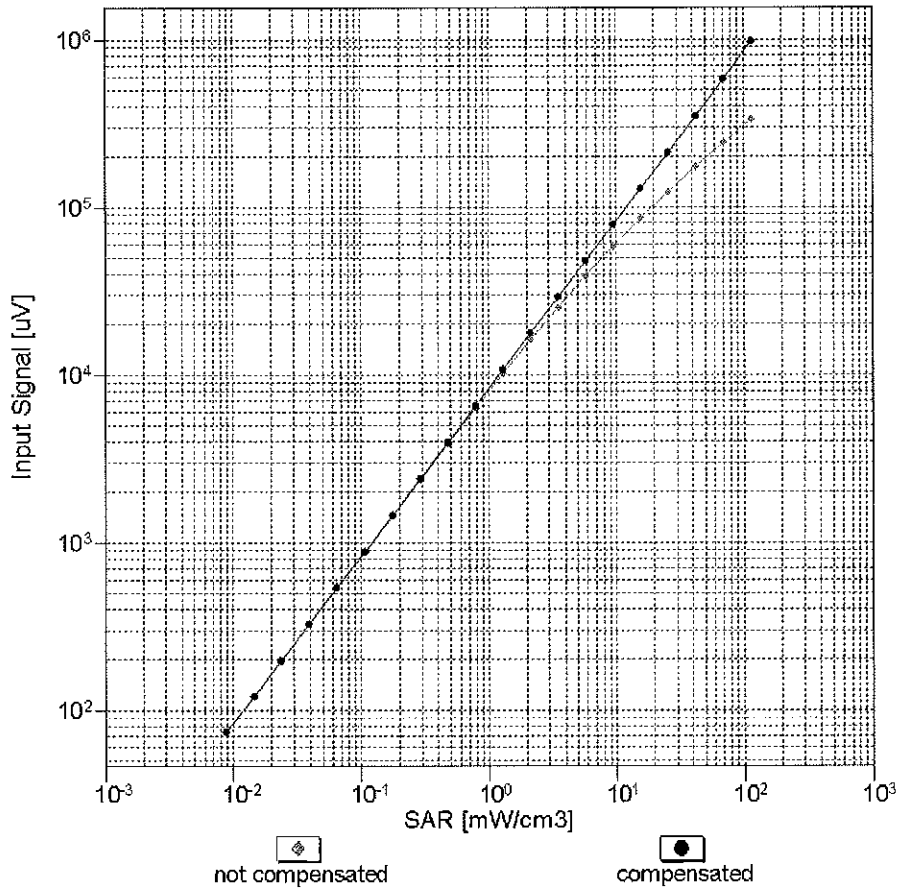

Uncertainty of Linearity Assessment: ± 0.6% (k=2)

Conversion Factor Assessment

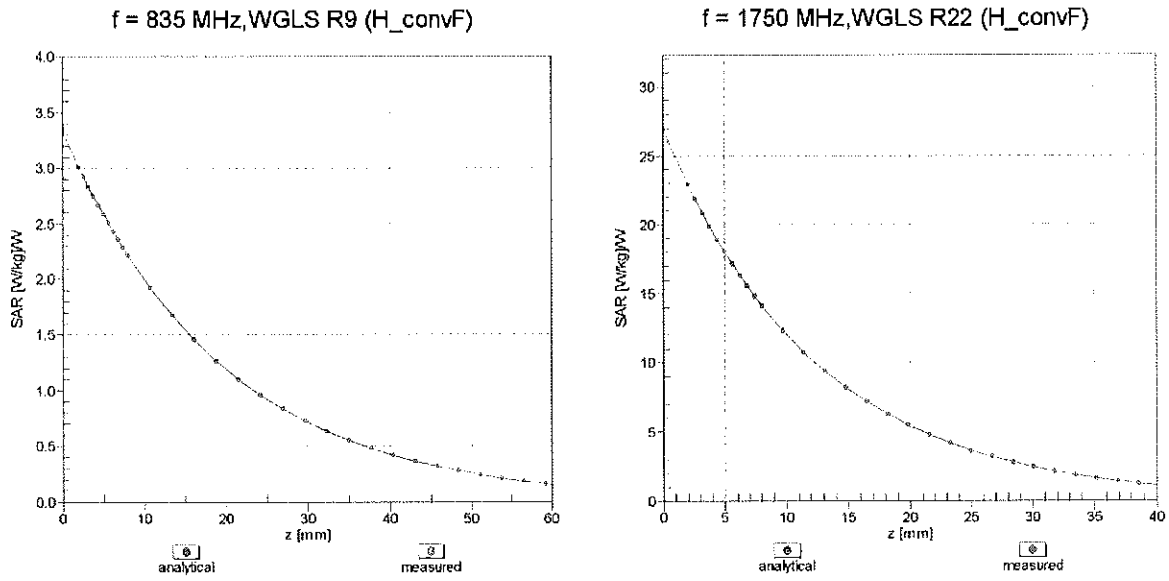

Deviation from Isotropy in Liquid Error (ϕ, ϑ), f = 900 MHz

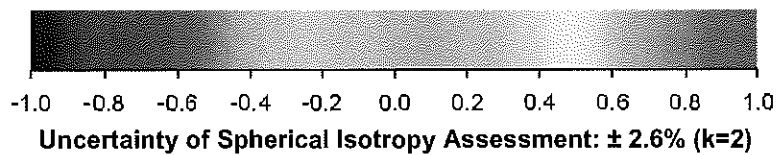
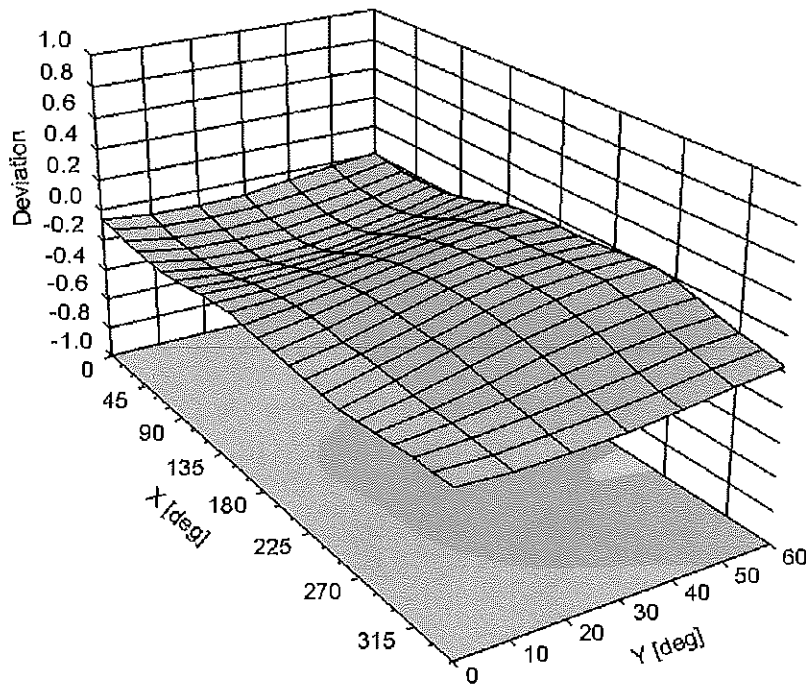

DASY/EASY - Parameters of Probe: ES3DV3 - SN:3258

Other Probe Parameters

Sensor Arrangement	Triangular
Connector Angle (°)	-123.1
Mechanical Surface Detection Mode	enabled
Optical Surface Detection Mode	disabled
Probe Overall Length	337 mm
Probe Body Diameter	10 mm
Tip Length	10 mm
Tip Diameter	4 mm
Probe Tip to Sensor X Calibration Point	2 mm
Probe Tip to Sensor Y Calibration Point	2 mm
Probe Tip to Sensor Z Calibration Point	2 mm
Recommended Measurement Distance from Surface	3 mm



Accredited by the Swiss Accreditation Service (SAS)
The Swiss Accreditation Service is one of the signatories to the EA
Multilateral Agreement for the recognition of calibration certificates

Accreditation No.: **SCS 108**

Client **PC Test**

Certificate No: **EX3-3920_Dec13**

CALIBRATION CERTIFICATE

Object **EX3DV4 - SN:3920**

Calibration procedure(s) **QA CAL-01.v9, QA CAL-14.v4, QA CAL-23.v5, QA CAL-25.v6
Calibration procedure for dosimetric E-field probes**

Calibration date: **December 18, 2013**

*VCC
1/12/14*

This calibration certificate documents the traceability to national standards, which realize the physical units of measurements (SI).
The measurements and the uncertainties with confidence probability are given on the following pages and are part of the certificate.

All calibrations have been conducted in the closed laboratory facility: environment temperature (22 ± 3)°C and humidity < 70%.

Calibration Equipment used (M&TE critical for calibration)

Primary Standards	ID	Cal Date (Certificate No.)	Scheduled Calibration
Power meter E4419B	GB41293874	04-Apr-13 (No. 217-01733)	Apr-14
Power sensor E4412A	MY41498087	04-Apr-13 (No. 217-01733)	Apr-14
Reference 3 dB Attenuator	SN: S5054 (3c)	04-Apr-13 (No. 217-01737)	Apr-14
Reference 20 dB Attenuator	SN: S5277 (20x)	04-Apr-13 (No. 217-01735)	Apr-14
Reference 30 dB Attenuator	SN: S5129 (30b)	04-Apr-13 (No. 217-01738)	Apr-14
Reference Probe ES3DV2	SN: 3013	28-Dec-12 (No. ES3-3013_Dec12)	Dec-13
DAE4	SN: 660	13-Dec-13 (No. DAE4-660_Dec13)	Dec-14
Secondary Standards	ID	Check Date (in house)	Scheduled Check
RF generator HP 8648C	US3642U01700	4-Aug-99 (in house check Apr-13)	In house check: Apr-15
Network Analyzer HP 8753E	US37390585	18-Oct-01 (in house check Oct-13)	In house check: Oct-14

	Name	Function	Signature
Calibrated by:	Leif Klysner	Laboratory Technician	<i>Leif Klysner</i>
Approved by:	Katja Pokovic	Technical Manager	<i>Katja Pokovic</i>

Issued: December 19, 2013

This calibration certificate shall not be reproduced except in full without written approval of the laboratory.



Accredited by the Swiss Accreditation Service (SAS)

Accreditation No.: **SCS 108**

The Swiss Accreditation Service is one of the signatories to the EA
Multilateral Agreement for the recognition of calibration certificates

Glossary:

TSL	tissue simulating liquid
NORM _{x,y,z}	sensitivity in free space
ConvF	sensitivity in TSL / NORM _{x,y,z}
DCP	diode compression point
CF	crest factor (1/duty_cycle) of the RF signal
A, B, C, D	modulation dependent linearization parameters
Polarization φ	φ rotation around probe axis
Polarization ϑ	ϑ rotation around an axis that is in the plane normal to probe axis (at measurement center), i.e., $\vartheta = 0$ is normal to probe axis
Connector Angle	information used in DASY system to align probe sensor X to the robot coordinate system

Calibration is Performed According to the Following Standards:

- IEEE Std 1528-2013, "IEEE Recommended Practice for Determining the Peak Spatial-Averaged Specific Absorption Rate (SAR) in the Human Head from Wireless Communications Devices: Measurement Techniques", June 2013
- IEC 62209-1, "Procedure to measure the Specific Absorption Rate (SAR) for hand-held devices used in close proximity to the ear (frequency range of 300 MHz to 3 GHz)", February 2005

Methods Applied and Interpretation of Parameters:

- NORM_{x,y,z}**: Assessed for E-field polarization $\vartheta = 0$ ($f \leq 900$ MHz in TEM-cell; $f > 1800$ MHz: R22 waveguide). NORM_{x,y,z} are only intermediate values, i.e., the uncertainties of NORM_{x,y,z} does not affect the E²-field uncertainty inside TSL (see below ConvF).
- NORM(f)_{x,y,z}** = NORM_{x,y,z} * frequency_response (see Frequency Response Chart). This linearization is implemented in DASY4 software versions later than 4.2. The uncertainty of the frequency response is included in the stated uncertainty of ConvF.
- DCP_{x,y,z}**: DCP are numerical linearization parameters assessed based on the data of power sweep with CW signal (no uncertainty required). DCP does not depend on frequency nor media.
- PAR**: PAR is the Peak to Average Ratio that is not calibrated but determined based on the signal characteristics
- A_{x,y,z}; B_{x,y,z}; C_{x,y,z}; D_{x,y,z}; VR_{x,y,z}; A, B, C, D** are numerical linearization parameters assessed based on the data of power sweep for specific modulation signal. The parameters do not depend on frequency nor media. VR is the maximum calibration range expressed in RMS voltage across the diode.
- ConvF and Boundary Effect Parameters**: Assessed in flat phantom using E-field (or Temperature Transfer Standard for $f \leq 800$ MHz) and inside waveguide using analytical field distributions based on power measurements for $f > 800$ MHz. The same setups are used for assessment of the parameters applied for boundary compensation (alpha, depth) of which typical uncertainty values are given. These parameters are used in DASY4 software to improve probe accuracy close to the boundary. The sensitivity in TSL corresponds to NORM_{x,y,z} * ConvF whereby the uncertainty corresponds to that given for ConvF. A frequency dependent ConvF is used in DASY version 4.4 and higher which allows extending the validity from ± 50 MHz to ± 100 MHz.
- Spherical isotropy (3D deviation from isotropy)**: in a field of low gradients realized using a flat phantom exposed by a patch antenna.
- Sensor Offset**: The sensor offset corresponds to the offset of virtual measurement center from the probe tip (on probe axis). No tolerance required.
- Connector Angle**: The angle is assessed using the information gained by determining the NORM_x (no uncertainty required).

Probe EX3DV4

SN:3920

Manufactured: December 18, 2012
Calibrated: December 18, 2013

Calibrated for DASY/EASY Systems
(Note: non-compatible with DASY2 system!)

DASY/EASY - Parameters of Probe: EX3DV4 - SN:3920

Basic Calibration Parameters

	Sensor X	Sensor Y	Sensor Z	Unc (k=2)
Norm ($\mu\text{V}/(\text{V}/\text{m})^2$) ^A	0.34	0.50	0.49	$\pm 10.1\%$
DCP (mV) ^B	102.9	99.5	98.3	

Modulation Calibration Parameters

UID	Communication System Name		A dB	B dB $\sqrt{\mu\text{V}}$	C	D dB	VR mV	Unc ^E (k=2)
0	CW	X	0.0	0.0	1.0	0.00	182.5	$\pm 2.7\%$
		Y	0.0	0.0	1.0		164.9	
		Z	0.0	0.0	1.0		153.0	
10010- CAA	SAR Validation (Square, 100ms, 10ms)	X	0.76	53.8	6.5	10.00	44.1	$\pm 2.2\%$
		Y	2.33	62.8	11.4		43.7	
		Z	1.15	55.6	7.5		53.0	
10011- CAA	UMTS-FDD (WCDMA)	X	3.36	66.5	17.5	2.91	142.4	$\pm 0.5\%$
		Y	3.15	65.0	16.7		131.4	
		Z	3.26	66.0	17.7		121.6	
10012- CAA	IEEE 802.11b WiFi 2.4 GHz (DSSS, 1 Mbps)	X	2.69	66.4	16.9	1.87	138.1	$\pm 0.5\%$
		Y	2.56	65.1	16.2		130.7	
		Z	2.72	66.6	17.2		121.4	
10021- DAA	GSM-FDD (TDMA, GMSK)	X	2.06	63.4	11.7	9.39	99.7	$\pm 1.9\%$
		Y	2.43	66.1	14.1		94.7	
		Z	2.90	69.9	16.1		121.8	
10023- DAA	GPRS-FDD (TDMA, GMSK, TN 0)	X	1.94	62.4	11.3	9.57	95.1	$\pm 1.9\%$
		Y	2.31	64.8	13.1		90.1	
		Z	2.98	70.4	16.4		117.0	
10024- DAA	GPRS-FDD (TDMA, GMSK, TN 0-1)	X	2.19	67.1	12.2	6.56	140.1	$\pm 1.4\%$
		Y	2.35	67.0	12.9		134.0	
		Z	3.45	73.5	16.1		131.4	
10027- DAA	GPRS-FDD (TDMA, GMSK, TN 0-1-2)	X	1.18	61.7	8.5	4.80	121.6	$\pm 1.2\%$
		Y	1.57	63.4	10.0		116.0	
		Z	1.57	65.5	11.9		109.2	
10028- DAA	GPRS-FDD (TDMA, GMSK, TN 0-1-2-3)	X	3.80	74.5	13.3	3.55	130.3	$\pm 0.9\%$
		Y	1.00	60.5	8.0		123.9	
		Z	1.58	66.1	11.1		119.0	
10032- CAA	IEEE 802.15.1 Bluetooth (GFSK, DH5)	X	0.18	55.2	3.4	1.16	111.6	$\pm 0.7\%$
		Y	0.34	57.4	4.4		143.6	
		Z	0.40	59.2	5.7		136.6	
10039- CAA	CDMA2000 (1xRTT, RC1)	X	4.49	65.9	18.1	4.57	131.8	$\pm 0.9\%$
		Y	4.57	65.1	17.5		123.0	
		Z	4.66	65.9	18.3		118.6	
10062- CAA	IEEE 802.11a/h WiFi 5 GHz (OFDM, 6 Mbps)	X	10.09	68.6	21.3	8.68	126.5	$\pm 2.5\%$
		Y	10.31	68.5	21.1		121.9	
		Z	10.12	68.3	21.3		115.8	

10098-CAA	UMTS-FDD (HSUPA, Subtest 2)	X	4.64	66.6	18.1	3.98	144.6	±0.7 %
		Y	4.54	65.4	17.4		133.9	
		Z	4.60	66.1	18.0		128.0	
10100-CAB	LTE-FDD (SC-FDMA, 100% RB, 20 MHz, QPSK)	X	6.00	65.5	18.3	5.67	104.2	±1.4 %
		Y	6.44	66.7	18.8		138.2	
		Z	6.54	67.4	19.4		134.7	
10108-CAB	LTE-FDD (SC-FDMA, 100% RB, 10 MHz, QPSK)	X	6.37	67.0	19.2	5.80	149.0	±1.4 %
		Y	6.40	66.6	18.9		141.2	
		Z	6.40	66.9	19.4		132.1	
10110-CAB	LTE-FDD (SC-FDMA, 100% RB, 5 MHz, QPSK)	X	5.96	66.3	18.9	5.75	142.3	±1.4 %
		Y	6.05	66.1	18.7		136.6	
		Z	6.03	66.3	19.1		128.2	
10114-CAA	IEEE 802.11n (HT Greenfield, 13.5 Mbps, BPSK)	X	10.28	68.7	20.9	8.10	137.3	±2.5 %
		Y	10.32	68.5	20.7		131.3	
		Z	10.24	68.5	20.9		124.5	
10117-CAA	IEEE 802.11n (HT Mixed, 13.5 Mbps, BPSK)	X	10.29	68.8	20.9	8.07	138.5	±2.5 %
		Y	10.34	68.6	20.8		131.9	
		Z	10.26	68.5	20.9		125.5	
10151-CAB	LTE-TDD (SC-FDMA, 50% RB, 20 MHz, QPSK)	X	7.20	67.5	21.6	9.28	118.6	±2.2 %
		Y	7.59	67.9	21.6		116.7	
		Z	7.78	69.2	22.7		110.7	
10154-CAB	LTE-FDD (SC-FDMA, 50% RB, 10 MHz, QPSK)	X	5.98	66.4	18.9	5.75	142.7	±1.2 %
		Y	5.97	65.7	18.4		132.7	
		Z	6.06	66.4	19.1		128.6	
10160-CAB	LTE-FDD (SC-FDMA, 50% RB, 15 MHz, QPSK)	X	6.41	66.8	19.1	5.82	147.7	±1.4 %
		Y	6.48	66.5	18.8		137.3	
		Z	6.53	67.0	19.4		134.9	
10169-CAB	LTE-FDD (SC-FDMA, 1 RB, 20 MHz, QPSK)	X	4.59	65.5	18.6	5.73	120.3	±1.2 %
		Y	4.76	65.0	18.2		113.9	
		Z	4.82	65.6	18.9		112.0	
10172-CAB	LTE-TDD (SC-FDMA, 1 RB, 20 MHz, QPSK)	X	5.77	69.3	22.7	9.21	128.1	±1.9 %
		Y	6.15	69.3	22.6		123.8	
		Z	6.22	70.3	23.6		120.8	
10175-CAB	LTE-FDD (SC-FDMA, 1 RB, 10 MHz, QPSK)	X	4.62	65.6	18.7	5.72	120.2	±0.9 %
		Y	4.75	65.0	18.2		113.5	
		Z	4.80	65.6	18.8		110.7	
10181-CAB	LTE-FDD (SC-FDMA, 1 RB, 15 MHz, QPSK)	X	4.57	65.4	18.6	5.72	118.9	±0.9 %
		Y	4.72	64.8	18.1		113.1	
		Z	4.81	65.6	18.8		110.4	
10193-CAA	IEEE 802.11n (HT Greenfield, 6.5 Mbps, BPSK)	X	9.77	68.3	20.8	8.09	128.1	±2.5 %
		Y	9.84	67.9	20.5		117.1	
		Z	9.80	68.1	20.8		116.6	
10196-CAA	IEEE 802.11n (HT Mixed, 6.5 Mbps, BPSK)	X	9.78	68.4	20.8	8.10	128.4	±2.5 %
		Y	9.86	68.0	20.5		120.3	
		Z	9.82	68.1	20.9		119.1	

10219-CAA	IEEE 802.11n (HT Mixed, 7.2 Mbps, BPSK)	X	9.70	68.4	20.8	8.03	128.0	±2.5 %
		Y	9.79	68.0	20.5		119.6	
		Z	9.72	68.1	20.8		118.7	
10222-CAA	IEEE 802.11n (HT Mixed, 15 Mbps, BPSK)	X	10.27	68.8	20.9	8.06	137.0	±2.5 %
		Y	10.18	68.3	20.6		125.2	
		Z	10.20	68.5	20.9		124.8	
10225-CAA	UMTS-FDD (HSPA+)	X	6.64	66.1	18.7	5.97	108.8	±1.4 %
		Y	7.23	67.1	19.1		148.9	
		Z	7.31	67.7	19.7		146.5	
10237-CAB	LTE-TDD (SC-FDMA, 1 RB, 10 MHz, QPSK)	X	5.82	69.6	23.0	9.21	130.2	±1.9 %
		Y	6.14	69.2	22.6		123.9	
		Z	6.25	70.4	23.7		122.2	
10252-CAB	LTE-TDD (SC-FDMA, 50% RB, 10 MHz, QPSK)	X	6.85	67.5	21.7	9.24	112.9	±2.2 %
		Y	7.54	69.0	22.4		149.2	
		Z	7.80	70.6	23.7		147.3	
10267-CAB	LTE-TDD (SC-FDMA, 100% RB, 10 MHz, QPSK)	X	7.23	67.6	21.6	9.30	118.3	±2.2 %
		Y	7.55	67.7	21.5		111.5	
		Z	7.79	69.2	22.7		109.6	
10274-CAA	UMTS-FDD (HSUPA, Subtest 5, 3GPP Rel8.10)	X	5.64	65.9	18.1	4.87	105.5	±1.2 %
		Y	6.04	66.4	18.2		142.6	
		Z	6.09	66.9	18.7		138.4	
10275-CAA	UMTS-FDD (HSUPA, Subtest 5, 3GPP Rel8.4)	X	4.42	66.3	18.1	3.96	135.8	±0.7 %
		Y	4.26	65.0	17.3		119.3	
		Z	4.40	65.9	18.0		120.4	
10291-AAA	CDMA2000, RC3, SO55, Full Rate	X	3.62	66.7	18.1	3.46	123.6	±0.7 %
		Y	3.38	64.3	16.7		112.5	
		Z	3.59	66.0	17.9		114.3	
10292-AAA	CDMA2000, RC3, SO32, Full Rate	X	3.46	66.0	17.7	3.39	127.3	±0.5 %
		Y	3.35	64.5	16.8		113.7	
		Z	3.50	65.7	17.7		115.4	
10297-AAA	LTE-FDD (SC-FDMA, 50% RB, 20 MHz, QPSK)	X	6.35	66.9	19.2	5.81	145.7	±1.2 %
		Y	6.26	66.1	18.7		129.2	
		Z	6.42	67.0	19.4		131.3	
10311-AAA	LTE-FDD (SC-FDMA, 100% RB, 15 MHz, QPSK)	X	6.45	65.9	18.7	6.06	103.7	±1.7 %
		Y	6.90	66.9	19.1		137.2	
		Z	7.04	67.7	19.8		137.5	
10315-AAA	IEEE 802.11b WiFi 2.4 GHz (DSSS, 1 Mbps, 96pc duty cycle)	X	2.85	67.8	17.7	1.71	135.6	±0.5 %
		Y	2.45	64.7	16.0		121.4	
		Z	2.75	67.3	17.6		122.1	
10317-AAA	IEEE 802.11a WiFi 5 GHz (OFDM, 6 Mbps, 96pc duty cycle)	X	9.93	68.5	21.0	8.36	128.1	±2.7 %
		Y	10.02	68.1	20.7		117.9	
		Z	10.01	68.3	21.1		119.4	
10400-AAA	IEEE 802.11ac WiFi (20MHz, 64-QAM, 99pc duty cycle)	X	10.09	68.8	21.2	8.37	134.9	±2.5 %
		Y	10.16	68.3	20.8		119.8	
		Z	10.14	68.5	21.2		121.0	

10402-AAA	IEEE 802.11ac WiFi (80MHz, 64-QAM, 99pc duty cycle)	X	11.18	69.8	21.5	8.53	147.1	±2.7 %
		Y	10.79	68.6	20.8		126.5	
		Z	11.17	69.6	21.6		131.4	
10403-AAA	CDMA2000 (1xEV-DO, Rev. 0)	X	4.83	69.6	18.9	3.76	139.6	±0.5 %
		Y	4.70	67.1	17.6		128.1	
		Z	4.90	68.4	18.6		127.8	
10404-AAA	CDMA2000 (1xEV-DO, Rev. A)	X	4.73	69.5	18.9	3.77	134.8	±0.5 %
		Y	4.62	67.1	17.7		124.9	
		Z	4.67	67.7	18.1		125.9	

The reported uncertainty of measurement is stated as the standard uncertainty of measurement multiplied by the coverage factor $k=2$, which for a normal distribution corresponds to a coverage probability of approximately 95%.

^A The uncertainties of NormX,Y,Z do not affect the E^2 -field uncertainty inside TSL (see Pages 8 and 9).

^B Numerical linearization parameter: uncertainty not required.

^E Uncertainty is determined using the max. deviation from linear response applying rectangular distribution and is expressed for the square of the field value.

DASY/EASY - Parameters of Probe: EX3DV4 - SN:3920

Calibration Parameter Determined in Head Tissue Simulating Media

f (MHz) ^C	Relative Permittivity ^F	Conductivity (S/m) ^F	ConvF X	ConvF Y	ConvF Z	Alpha ^G	Depth ^G (mm)	Unct. (k=2)
750	41.9	0.89	10.05	10.05	10.05	0.27	1.13	± 12.0 %
835	41.5	0.90	9.69	9.69	9.69	0.50	0.76	± 12.0 %
1750	40.1	1.37	7.91	7.91	7.91	0.72	0.62	± 12.0 %
1900	40.0	1.40	7.70	7.70	7.70	0.77	0.61	± 12.0 %
2450	39.2	1.80	6.98	6.98	6.98	0.37	0.86	± 12.0 %
2600	39.0	1.96	6.74	6.74	6.74	0.34	0.97	± 12.0 %
5200	36.0	4.66	4.87	4.87	4.87	0.40	1.80	± 13.1 %
5300	35.9	4.76	4.66	4.66	4.66	0.40	1.80	± 13.1 %
5500	35.6	4.96	4.54	4.54	4.54	0.40	1.80	± 13.1 %
5600	35.5	5.07	4.37	4.37	4.37	0.40	1.80	± 13.1 %
5800	35.3	5.27	4.11	4.11	4.11	0.50	1.80	± 13.1 %

^C Frequency validity of ± 100 MHz only applies for DASY v4.4 and higher (see Page 2), else it is restricted to ± 50 MHz. The uncertainty is the RSS of the ConvF uncertainty at calibration frequency and the uncertainty for the indicated frequency band.

^F At frequencies below 3 GHz, the validity of tissue parameters (ϵ and σ) can be relaxed to ± 10% if liquid compensation formula is applied to measured SAR values. At frequencies above 3 GHz, the validity of tissue parameters (ϵ and σ) is restricted to ± 5%. The uncertainty is the RSS of the ConvF uncertainty for indicated target tissue parameters.

^G Alpha/Depth are determined during calibration. SPEAG warrants that the remaining deviation due to the boundary effect after compensation is always less than ± 1% for frequencies below 3 GHz and below ± 2% for frequencies between 3-6 GHz at any distance larger than half the probe tip diameter from the boundary.

DASY/EASY - Parameters of Probe: EX3DV4 - SN:3920

Calibration Parameter Determined in Body Tissue Simulating Media

f (MHz) ^C	Relative Permittivity ^F	Conductivity (S/m) ^F	ConvF X	ConvF Y	ConvF Z	Alpha ^G	Depth ^G (mm)	Unct. (k=2)
750	55.5	0.96	9.54	9.54	9.54	0.32	1.07	± 12.0 %
835	55.2	0.97	9.47	9.47	9.47	0.45	0.85	± 12.0 %
1750	53.4	1.49	7.77	7.77	7.77	0.59	0.74	± 12.0 %
1900	53.3	1.52	7.50	7.50	7.50	0.37	0.91	± 12.0 %
2450	52.7	1.95	7.18	7.18	7.18	0.80	0.56	± 12.0 %
2600	52.5	2.16	6.91	6.91	6.91	0.80	0.57	± 12.0 %
5200	49.0	5.30	4.23	4.23	4.23	0.50	1.90	± 13.1 %
5300	48.9	5.42	4.11	4.11	4.11	0.50	1.90	± 13.1 %
5500	48.6	5.65	3.80	3.80	3.80	0.50	1.90	± 13.1 %
5600	48.5	5.77	3.62	3.62	3.62	0.50	1.90	± 13.1 %
5800	48.2	6.00	4.00	4.00	4.00	0.50	1.90	± 13.1 %

^C Frequency validity of ± 100 MHz only applies for DASY v4.4 and higher (see Page 2), else it is restricted to ± 50 MHz. The uncertainty is the RSS of the ConvF uncertainty at calibration frequency and the uncertainty for the indicated frequency band.

^F At frequencies below 3 GHz, the validity of tissue parameters (ϵ and σ) can be relaxed to ± 10% if liquid compensation formula is applied to measured SAR values. At frequencies above 3 GHz, the validity of tissue parameters (ϵ and σ) is restricted to ± 5%. The uncertainty is the RSS of the ConvF uncertainty for indicated target tissue parameters.

^G Alpha/Depth are determined during calibration. SPEAG warrants that the remaining deviation due to the boundary effect after compensation is always less than ± 1% for frequencies below 3 GHz and below ± 2% for frequencies between 3-6 GHz at any distance larger than half the probe tip diameter from the boundary.

Frequency Response of E-Field (TEM-Cell:ifi110 EXX, Waveguide: R22)

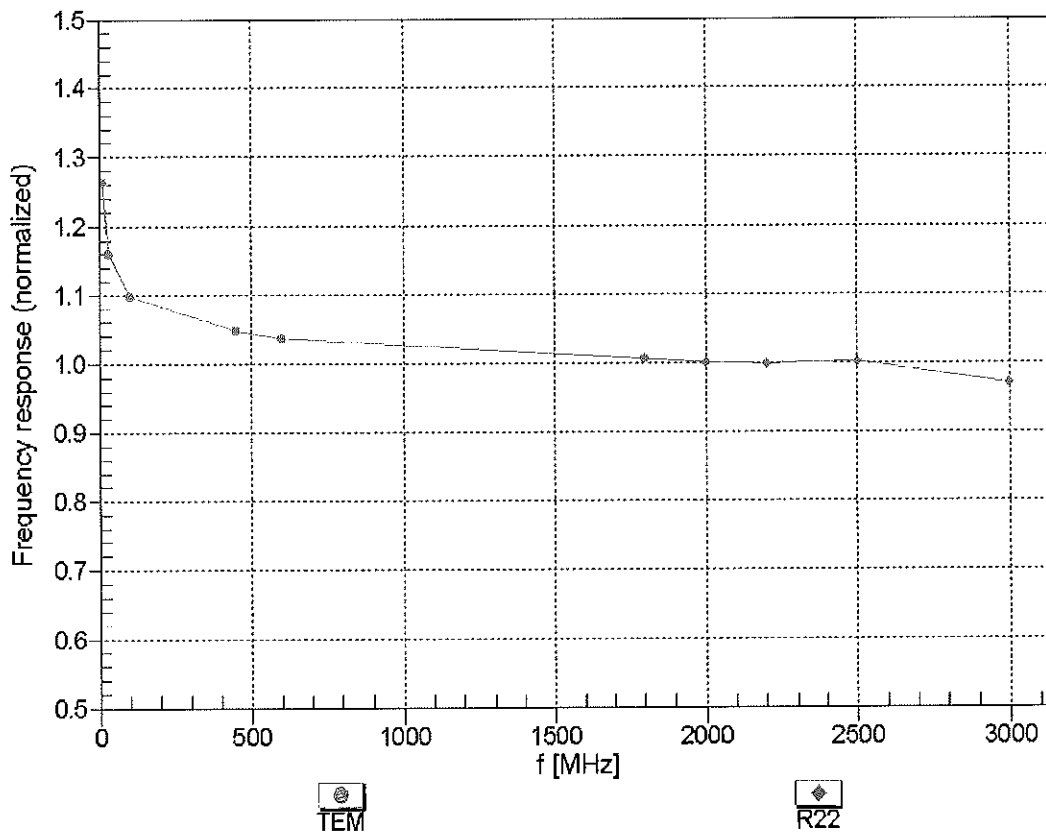

Uncertainty of Frequency Response of E-field: $\pm 6.3\%$ (k=2)

Receiving Pattern (ϕ), $\theta = 0^\circ$

f=600 MHz,TEM

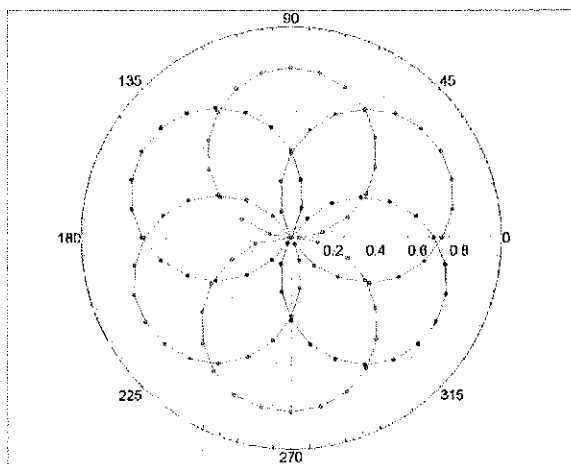

f=1800 MHz,R22

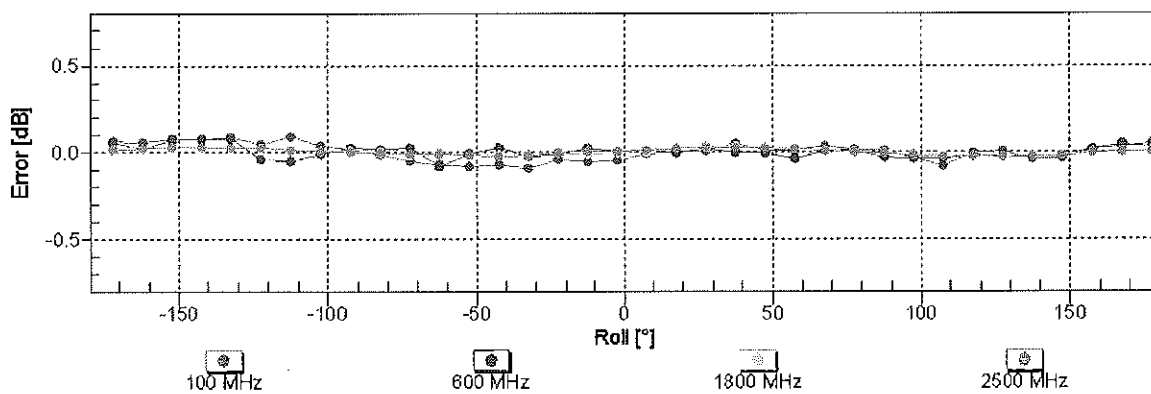
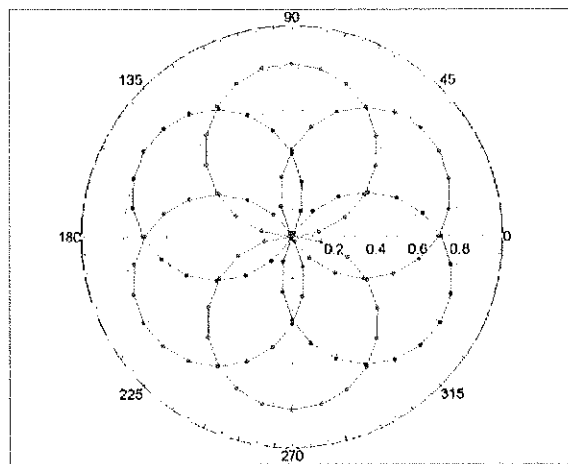

Uncertainty of Axial Isotropy Assessment: $\pm 0.5\%$ (k=2)

Dynamic Range f(SAR_{head}) (TEM cell , f = 900 MHz)

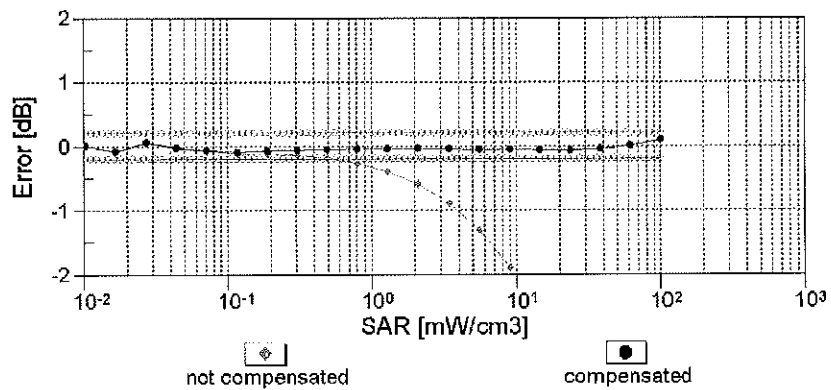
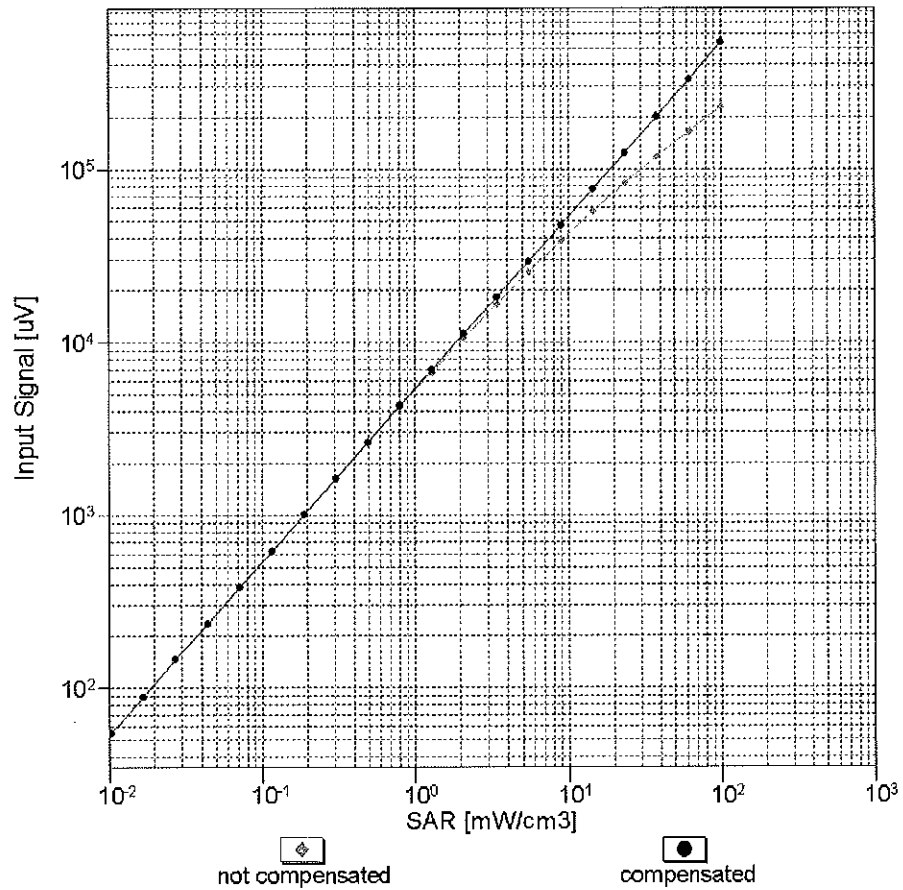

Uncertainty of Linearity Assessment: ± 0.6% (k=2)

Conversion Factor Assessment

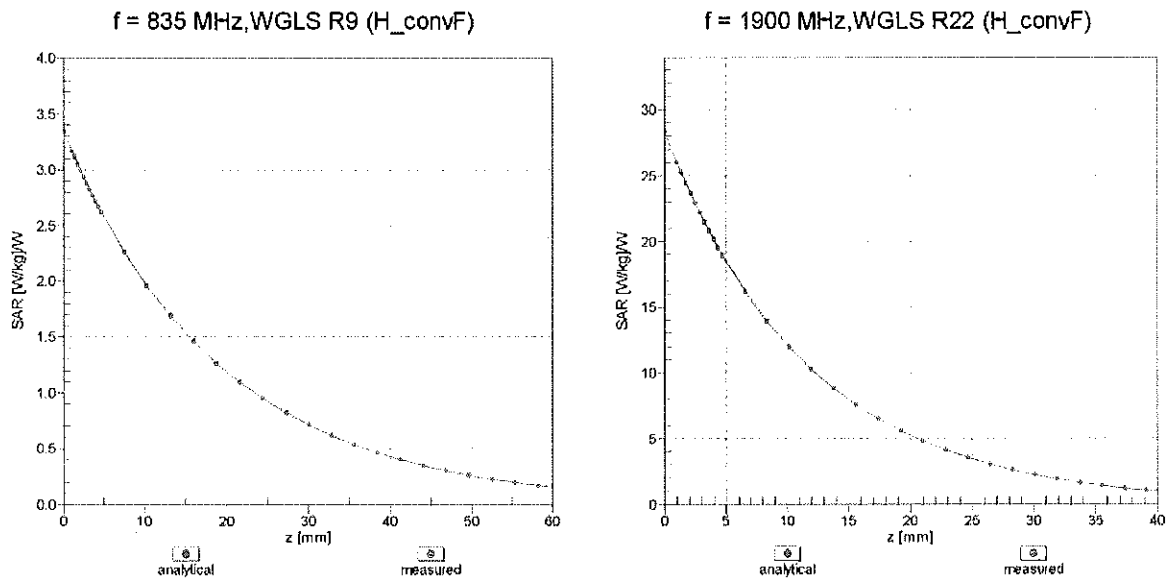

Deviation from Isotropy in Liquid Error (ϕ, θ), f = 900 MHz

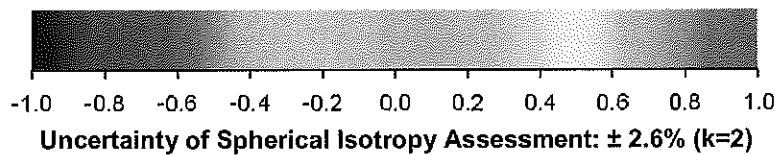
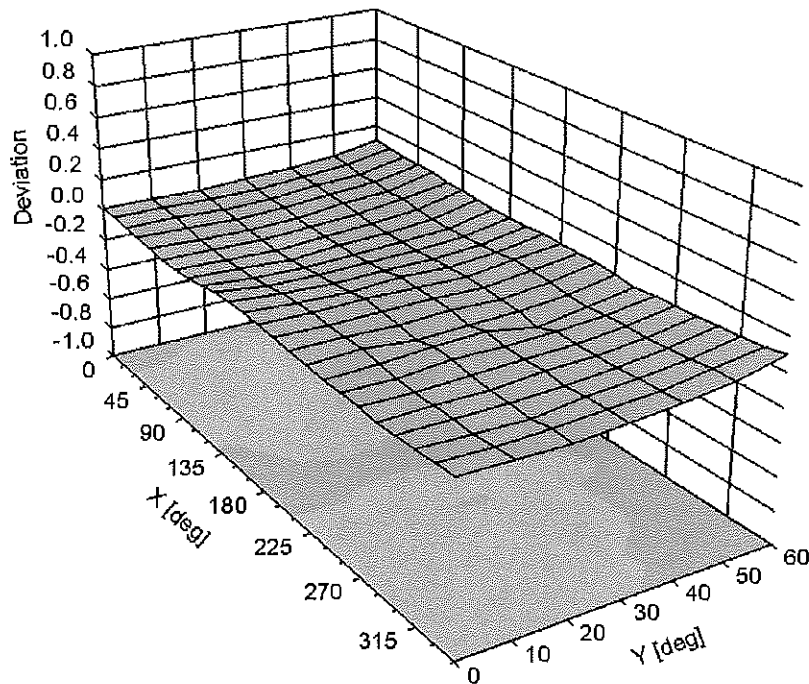

DASY/EASY - Parameters of Probe: EX3DV4 - SN:3920

Other Probe Parameters

Sensor Arrangement	Triangular
Connector Angle (°)	-22.4
Mechanical Surface Detection Mode	enabled
Optical Surface Detection Mode	disabled
Probe Overall Length	337 mm
Probe Body Diameter	10 mm
Tip Length	9 mm
Tip Diameter	2.5 mm
Probe Tip to Sensor X Calibration Point	1 mm
Probe Tip to Sensor Y Calibration Point	1 mm
Probe Tip to Sensor Z Calibration Point	1 mm
Recommended Measurement Distance from Surface	2 mm

APPENDIX D: SAR TISSUE SPECIFICATIONS

Measurement Procedure for Tissue verification:



- 1) The network analyzer and probe system was configured and calibrated.
- 2) The probe was immersed in the tissue. The tissue was placed in a nonmetallic container. Trapped air bubbles beneath the flange were minimized by placing the probe at a slight angle.
- 3) The complex admittance with respect to the probe aperture was measured
- 4) The complex relative permittivity ϵ can be calculated from the below equation (Pournaropoulos and Misra):

$$Y = \frac{j2\omega\epsilon_r\epsilon_0}{[\ln(b/a)]^2} \int_a^b \int_a^b \int_0^\pi \cos\phi' \frac{\exp[-j\omega r(\mu_0\epsilon_r'\epsilon_0)^{1/2}]}{r} d\phi' d\rho' d\rho$$

where Y is the admittance of the probe in contact with the sample, the primed and unprimed coordinates refer to source and observation points, respectively, $r^2 = \rho^2 + \rho'^2 - 2\rho\rho' \cos\phi'$, ω is the angular frequency, and $j = \sqrt{-1}$.

**Table D-1
Composition of the Tissue Equivalent Matter**

Frequency (MHz)	750	1750	2450	5200-5800
Tissue	Body	Body	Body	Body
Ingredients (% by weight)				
DGBE	See Next Page	31	26.7	
NaCl		0.2	0.1	
Polysorbate (Tween) 80				20
Water		68.8	73.2	80

FCC ID: ZNFVK410		SAR EVALUATION REPORT		Reviewed by: Quality Manager
Test Dates: 06/02/14 - 06/04/14	DUT Type: Portable Tablet			APPENDIX D: Page 1 of 2

2 Composition / Information on ingredients

The Item is composed of the following ingredients:

H ₂ O	Water, 35 – 58%
Sucrose	Sugar, white, refined, 40 – 60%
NaCl	Sodium Chloride, 0 – 6%
Hydroxyethyl-cellulose	Medium Viscosity (CAS# 9004-62-0), <0.3%
Preventol-D7	Preservative: aqueous preparation, (CAS# 55965-84-9), containing 5-chloro-2-methyl-3(2H)-isothiazolone and 2-methyl-3(2H)-isothiazolone, 0.1 – 0.7%

Relevant for safety; Refer to the respective Safety Data Sheet*.

**Figure D-1
Composition of 750 MHz Body Tissue Equivalent Matter**

Note: 750MHz liquid recipes are proprietary SPEAG. Since the composition is approximate to the actual liquids utilized, the manufacturer tissue-equivalent liquid data sheets are provided below.

Measurement Certificate / Material Test

Item Name	Body Tissue Simulating Liquid (MSL750V2)
Product No.	SL AAM 075 AA (Charge: 130313-1)
Manufacturer	SPEAG

Measurement Method
TSL dielectric parameters measured using calibrated OCP probe.

Setup Validation
Validation results were within $\pm 2.5\%$ towards the target values of Methanol.

Target Parameters
Target parameters as defined in the IEEE 1528 and IEC 62209 compliance standards.

Test Condition
Ambient Environment temperature (22 ± 3)°C and humidity < 70%.
TSL Temperature 22°C
Test Date 13-Mar-13
Operator IEN

Additional Information
TSL Density 1.212 g/cm³
TSL Heat-capacity 3.006 kJ/(kg*K)

f [MHz]	Measured			Target		Diff.to Target [%]	
	HP-e'	HP-e''	sigma	eps	sigma	Δ -eps	Δ -sigma
600	57.5	24.64	0.82	56.1	0.95	2.5	-13.6
625	57.2	24.31	0.84	56.0	0.95	2.1	-11.4
650	57.0	23.99	0.87	55.9	0.96	1.8	-9.2
675	56.7	23.69	0.89	55.8	0.96	1.5	-7.1
700	56.4	23.39	0.91	55.7	0.96	1.2	-5.1
725	56.2	23.18	0.93	55.6	0.96	1.0	-2.8
750	55.9	22.97	0.96	55.5	0.96	0.7	-0.5
775	55.7	22.78	0.98	55.4	0.97	0.4	1.7
800	55.4	22.60	1.01	55.3	0.97	0.1	4.0
825	55.2	22.44	1.03	55.2	0.98	-0.2	5.3
850	55.0	22.36	1.04	55.2	0.98	-0.3	5.9
875	54.9	22.28	1.05	55.2	0.99	-0.4	6.6
900	54.7	22.16	1.08	55.1	1.02	-0.7	5.8
925	54.5	22.03	1.10	55.0	1.05	-1.0	5.1
950	54.2	21.83	1.13	55.0	1.06	-1.3	6.2
975	54.0	21.82	1.15	54.9	1.08	-1.7	7.2
1000	53.8	21.74	1.18	54.9	1.09	-2.0	8.5
	53.6	21.66	1.21	54.8	1.10	-2.3	9.7

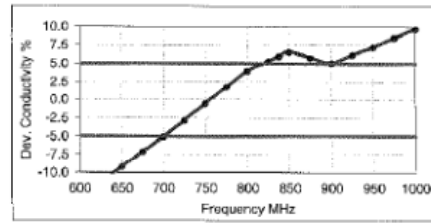
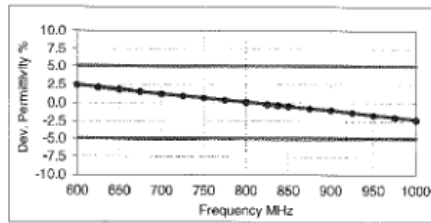

**Figure D-2
750MHz Body Tissue Equivalent Matter**

FCC ID: ZNFVK410		SAR EVALUATION REPORT		Reviewed by: Quality Manager
Test Dates: 06/02/14 - 06/04/14	DUT Type: Portable Tablet			APPENDIX D: Page 2 of 2

APPENDIX E: SAR SYSTEM VALIDATION



Per FCC KDB 865664 D02v01, SAR system validation status should be documented to confirm measurement accuracy. The SAR systems (including SAR probes, system components and software versions) used for this device were validated against its performance specifications prior to the SAR measurements. Reference dipoles were used with the required tissue- equivalent media for system validation, according to the procedures outlined in FCC KDB 865664 D01 v01 and IEEE 1528-2013. Since SAR probe calibrations are frequency dependent, each probe calibration point was validated at a frequency within the valid frequency range of the probe calibration point, using the system that normally operates with the probe for routine SAR measurements and according to the required tissue-equivalent media.

A tabulated summary of the system validation status including the validation date(s), measurement frequencies, SAR probes and tissue dielectric parameters has been included.



Table E-I
SAR System Validation Summary

SAR SYSTEM #	FREQ. [MHz]	DATE	PROBE SN	PROBE TYPE	PROBE CAL. POINT		COND.	PERM.	CW VALIDATION			MOD. VALIDATION		
							(σ)	(ϵ_r)	SENSI- TIVITY	PROBE LINEARITY	PROBE ISOTROPY	MOD. TYPE	DUTY FACTOR	PAR
J	750	1/22/2014	3332	ES3DV3	750	Body	0.951	54.04	PASS	PASS	PASS	N/A	N/A	N/A
K	1750	1/14/2014	3333	ES3DV3	1750	Body	1.510	52.07	PASS	PASS	PASS	N/A	N/A	N/A
G	2450	3/5/2014	3258	ES3DV3	2450	Body	2.044	51.30	PASS	PASS	PASS	OFDM	N/A	PASS
A	5200	1/13/2014	3920	EX3DV4	5200	Body	5.344	47.27	PASS	PASS	PASS	OFDM	N/A	PASS
A	5300	1/13/2014	3920	EX3DV4	5300	Body	5.500	46.91	PASS	PASS	PASS	OFDM	N/A	PASS
A	5500	1/13/2014	3920	EX3DV4	5500	Body	5.826	46.38	PASS	PASS	PASS	OFDM	N/A	PASS
A	5600	1/13/2014	3920	EX3DV4	5600	Body	5.991	46.16	PASS	PASS	PASS	OFDM	N/A	PASS
A	5800	1/23/2014	3920	EX3DV4	5800	Body	6.282	46.05	PASS	PASS	PASS	OFDM	N/A	PASS

NOTE: While the probes have been calibrated for both a CW and modulated signals, all measurements were performed using communication systems calibrated for CW signals only. Modulations in the table above represent test configurations for which the measurement system has been validated per FCC KDB Publication 865664 D01v01 for scenarios when CW probe calibrations are used with other signal types. SAR systems were validated for modulated signals with a periodic duty cycle, such as GMSK, or with a high peak to average ratio (>5 dB), such as OFDM according to KDB 865664

FCC ID: ZNFVK410		SAR EVALUATION REPORT		Reviewed by: Quality Manager
Test Dates: 06/02/14 - 06/04/14	DUT Type: Portable Tablet			APPENDIX E: Page 1 of 1

APPENDIX G: SENSOR TRIGGERING DATA SUMMARY

FCC ID: ZNFVK410	 PCTEST ENGINEERING LABORATORY, INC.	SAR EVALUATION REPORT	 LG	Reviewed by: Quality Manager
Test Dates: 06/02/14 - 06/04/14	DUT Type: Portable Tablet			APPENDIX G: Page 1 of 4

ZNFVK410 Sensor Triggering Data Summary

Per FCC KDB Publication 616217 D04, this device was tested by the manufacturer to determine the proximity sensor triggering distances for the back side and top and right edges of the device. The measured output power within ± 5 mm of the triggering points (or until touching the phantom) is included for back side and each applicable edge.

To ensure all production units are compliant it is necessary to test SAR at a distance 1mm less than the smallest distance from the device and SAR phantom (determined from these triggering tests according to the KDB 616217 D04) with the device at maximum output power without power reduction. These additional SAR Tests are included additionally to the SAR tests for the device touching the SAR phantom, with reduced power.

The operational description contains information explaining how this device remains compliant in the event of a sensor malfunction.

Back Side



Moving device toward the phantom:

KDB 616217 6.2.6 Measured Power [dBm]											
Distance [mm]	20	19	18	17	16	15	14	13	12	11	10
LTE B13	24.20	24.20	24.20	24.20	24.20	20.20	20.20	20.20	20.20	20.20	20.20
LTE B4	24.20	24.20	24.20	24.20	24.20	14.20	14.20	14.20	14.20	14.20	14.20

Moving device away from the phantom:

KDB 616217 6.2.8 Measured Power [dBm]												
Distance [mm]	20	19	18	17	16	15	14	13	12	11	10	9
LTE B13	24.20	24.20	24.20	24.20	24.20	20.20	20.20	20.20	20.20	20.20	20.20	20.20
LTE B4	24.20	24.20	24.20	24.20	24.20	14.20	14.20	14.20	14.20	14.20	14.20	14.20

Based on the most conservative measured triggering distance of 15 mm, additional SAR measurements were required at 14 mm from the back side.

FCC ID: ZNFVK410	 PCTEST ENGINEERING LABORATORY, INC.	SAR EVALUATION REPORT		Reviewed by: Quality Manager
Test Dates: 06/02/14 - 06/04/14	DUT Type: Portable Tablet			APPENDIX G: Page 2 of 4

Top Edge



Moving device toward the phantom:

KDB 616217 6.2.6 Measured Power [dBm]											
Distance [mm]	22	21	20	19	18	17	16	15	14	13	12
LTE B13	24.20	24.20	24.20	24.20	24.20	20.20	20.20	20.20	20.20	20.20	20.20
LTE B4	24.20	24.20	24.20	24.20	24.20	14.20	14.20	14.20	14.20	14.20	14.20

Moving device away from the phantom:

KDB 616217 6.2.8 Measured Power [dBm]												
Distance [mm]	22	21	20	19	18	17	16	15	14	13	12	11
LTE B13	24.20	24.20	24.20	24.20	24.20	20.20	20.20	20.20	20.20	20.20	20.20	20.20
LTE B4	24.20	24.20	24.20	24.20	24.20	14.20	14.20	14.20	14.20	14.20	14.20	14.20

Based on the most conservative measured triggering distance of 17 mm, additional SAR measurements were required at 16 mm from the top edge.

FCC ID: ZNFVK410	 PCTEST ENGINEERING LABORATORY, INC.	SAR EVALUATION REPORT	 LG	Reviewed by: Quality Manager
Test Dates: 06/02/14 - 06/04/14	DUT Type: Portable Tablet			APPENDIX G: Page 3 of 4

Right Edge



Moving device toward the phantom:

KDB 616217 6.2.6 Measured Power [dBm]											
Distance [mm]	13	12	11	10	9	8	7	6	5	4	3
LTE B13	24.20	24.20	24.20	24.20	24.20	20.20	20.20	20.20	20.20	20.20	20.20
LTE B4	24.20	24.20	24.20	24.20	24.20	14.20	14.20	14.20	14.20	14.20	14.20

Moving device away from the phantom:

KDB 616217 6.2.8 Measured Power [dBm]												
Distance [mm]	13	12	11	10	9	8	7	6	5	4	3	2
LTE B13	24.20	24.20	24.20	24.20	24.20	20.20	20.20	20.20	20.20	20.20	20.20	20.20
LTE B4	24.20	24.20	24.20	24.20	24.20	14.20	14.20	14.20	14.20	14.20	14.20	14.20

Based on the most conservative measured triggering distance of 8 mm, additional SAR measurements were required at 7 mm from the right edge.

FCC ID: ZNFVK410	 PCTEST ENGINEERING LABORATORY, INC.	SAR EVALUATION REPORT	 LG	Reviewed by: Quality Manager
Test Dates: 06/02/14 - 06/04/14	DUT Type: Portable Tablet			APPENDIX G: Page 4 of 4