



**FCC CFR47 PART 22 SUBPART H
FCC CFR47 PART 24 SUBPART E**

CERTIFICATION TEST REPORT

FOR

SMART WATCH + CDMA

MODEL NUMBER: LG-VC100, LGVC100, VC100, LG-VC100P, LGVC100P, VC100P

FCC ID: ZNFVC100

REPORT NUMBER: 14U18513-E1

ISSUE DATE: SEPTEMBER 03, 2014

Prepared for

**LG ELECTRONICS MOBILECOMM U.S.A., INC
1000 SYLVAN AVENUE
ENGLEWOOD CLIFFS,
NEW JERSEY, 07632, U.S.A**

Prepared by

**UL VERIFICATION SERVICES
47173 BENICIA STREET
FREMONT, CA 94538, U.S.A.
TEL: (510) 771-1000
FAX: (510) 661-0888**



NVLAP LAB CODE 200065-0

Revision History

<u>Rev.</u>	<u>Issue Date</u>	<u>Revisions</u>	<u>Revised By</u>
--	9/3/14	Initial issue	D. Corona

TABLE OF CONTENTS

1.	ATTESTATION OF TEST RESULTS	5
2.	TEST METHODOLOGY	6
3.	FACILITIES AND ACCREDITATION	6
4.	CALIBRATION AND UNCERTAINTY	6
4.1.	MEASURING INSTRUMENT CALIBRATION	6
4.2.	SAMPLE CALCULATION	6
4.3.	MEASUREMENT UNCERTAINTY	7
5.	EQUIPMENT UNDER TEST	8
5.1.	DESCRIPTION OF EUT	8
5.2.	MAXIMUM OUTPUT POWER	8
5.3.	DESCRIPTION OF AVAILABLE ANTENNAS	9
5.4.	DESCRIPTION OF TEST SETUP	10
6.	TEST AND MEASUREMENT EQUIPMENT	13
7.	Summary Table.....	14
8.	CDMA2000	15
8.1.1.	1xRTT.....	15
8.1.2.	CDMA2000 OUTPUT POWER RESULT	16
8.1.3.	1xEV-DO Release 0.....	17
8.1.4.	1XEVDO REL 0 OUTPUT POWER RESULT.....	18
8.1.5.	1xEV-DO Rev. A.....	19
8.1.6.	1xEVDO REV A OUTPUT RESULT.....	20
8.1.7.	1xEV-DO Rev. B.....	21
8.1.8.	1xEVDO REV B OUTPUT RESULT.....	22
9.	PEAK TO AVERAGE RATIO	23
9.1.	CONDUCTED PEAK TO AVERAGE RESULT	23
10.	LIMITS AND CONDUCTED RESULTS	25
10.1.	OCCUPIED BANDWIDTH.....	25
10.1.1.	OCCUPIED BANDWIDTH RESULTS.....	26
10.1.2.	OCCUPIED BANDWIDTH PLOTS	27
11.	BAND EDGE EMISSIONS	29
11.1.	BAND EDGE PLOTS.....	30
12.	OUT OF BAND EMISSIONS.....	32

12.1.	OUT OF BAND EMISSIONS RESULT	33
12.2.	OUT OF BAND EMISSIONS PLOTS.....	34
13.	FREQUENCY STABILITY.....	36
13.1.	FREQUENCY STABILITY RESULTS.....	37
14.	RADIATED TEST RESULTS	39
14.1.	RADIATED POWER (ERP & EIRP).....	39
14.1.1.	ERP/EIRP Results.....	40
14.1.2.	ERP/EIRP PLOTS.....	41
15.	FIELD STRENGTH OF SPURIOUS RADIATION	43
15.1.	SPURIOUS RADIATION PLOTS.....	44
16.	SETUP PHOTOS	46

1. ATTESTATION OF TEST RESULTS

COMPANY NAME: LG ELECTRONICS MOBILECOMM U.S.A., INC.
EUT DESCRIPTION: SMART WATCH + CDMA
MODEL: LG-VC100, LGVC100, VC100, LG-VC100P, LGVC100P, VC100P
SERIAL NUMBER: 1-Conducted, 2-Radiated
DATE TESTED: AUGUST 28 -29, 2014

APPLICABLE STANDARDS	
STANDARD	TEST RESULTS
FCC PART 22H and 24E	PASS

UL Verification Services Inc. tested the above equipment in accordance with the requirements set forth in the above standards. All indications of Pass/Fail in this report are opinions expressed by UL Verification Services Inc. based on interpretations and/or observations of test results. Measurement Uncertainties were not taken into account and are published for informational purposes only. The test results show that the equipment tested is capable of demonstrating compliance with the requirements as documented in this report.

Note: The results documented in this report apply only to the tested sample, under the conditions and modes of operation as described herein. This document may not be altered or revised in any way unless done so by UL Verification Services Inc. and all revisions are duly noted in the revisions section. Any alteration of this document not carried out by UL Verification Services Inc. will constitute fraud and shall nullify the document. This report must not be used by the client to claim product certification, approval, or endorsement by NVLAP, NIST, any agency of the Federal Government, or any agency of any government.

Approved & Released For
UL Verification Services Inc. By:



DAN CORONIA
CONSUMER TECHNOLOGY DIVISION
PROJECT LEAD
UL Verification Services Inc.

Tested By:



STEVEN TRAN
CONSUMER TECHNOLOGY DIVISION
LAB ENGINEER
UL Verification Services Inc.

2. TEST METHODOLOGY

The tests documented in this report were performed in accordance with TIA-603-C, FCC CFR 47 Part 22, FCC CFR Part 24.

3. FACILITIES AND ACCREDITATION

The test sites and measurement facilities used to collect data are located at 47173 and 47266 Benicia Street, Fremont, California, USA. Line conducted emissions are measured only at the 47173 address. The following table identifies which facilities were utilized for radiated emission measurements documented in this report. Specific facilities are also identified in the test results sections.

47173 Benicia Street	47266 Benicia Street
<input type="checkbox"/> Chamber A	<input type="checkbox"/> Chamber D
<input checked="" type="checkbox"/> Chamber B	<input type="checkbox"/> Chamber E
<input type="checkbox"/> Chamber C	<input type="checkbox"/> Chamber F
	<input type="checkbox"/> Chamber G
	<input type="checkbox"/> Chamber H

UL Verification Services Inc. is accredited by NVLAP, Laboratory Code 200065-0. The full scope of accreditation can be viewed at <http://ts.nist.gov/standards/scopes/2000650.htm>.

4. CALIBRATION AND UNCERTAINTY

4.1. MEASURING INSTRUMENT CALIBRATION

The measuring equipment utilized to perform the tests documented in this report has been calibrated in accordance with the manufacturer's recommendations, and is traceable to recognized national standards

4.2. SAMPLE CALCULATION

Where relevant, the following sample calculation is provided:

$$\text{EIRP} = \text{PSA reading with EUT worst orientation (dBm)} + \text{Path loss (dB)} - \text{cable loss}$$

(between the SG and substitution antenna) + Substitution Antenna Factor (dBi)

$$\text{ERP} = \text{PSA reading with EUT worst orientation (dBm)} + \text{Path loss (dB)} - \text{cable loss}$$

(between the SG and substitution antenna)

(Path loss = Signal generator output – PSA reading with substitution antenna)

4.3. MEASUREMENT UNCERTAINTY

Where relevant, the following measurement uncertainty levels have been estimated for tests performed on the apparatus:

PARAMETER	UNCERTAINTY
Conducted Disturbance, 0.15 to 30 MHz	3.52 dB
Radiated Disturbance, 30 to 1000 MHz	4.94 dB

Uncertainty figures are valid to a confidence level of 95%.

5. EQUIPMENT UNDER TEST

5.1. DESCRIPTION OF EUT

SMART WATCH + CDMA

5.2. MAXIMUM OUTPUT POWER

The transmitter has a maximum peak conducted and radiated ERP / EIRP output powers as follows:

FCC Part 22/24						
Band	Frequency Range(MHz)	Modulation Peak	Conducted		Radiated	
			dBm	mW	dBm	mW
BC0	824~849	1xRTT	24.5	281.84	25.59	362.24
	824~849	EVDO REL. 0				
	824~849	EVDO REV. A				
BC1	1850~1910	1xRTT	21.2	131.83	21.41	138.36
	1850~1910	EVDO REL. 0				
	1850~1910	EVDO REV. A				

5.3. DESCRIPTION OF AVAILABLE ANTENNAS

The radio utilizes a PIFA antenna for the [List the bands supported] with a maximum peak gain as follow:

Frequency (MHz)	Peak Gain (dBi)
BC0, 824~849MHz	3.32
BC1, 1850~1910MHz	1.98

5.4. DESCRIPTION OF TEST SETUP

SUPPORT EQUIPMENT

Support Equipment List				
Description	Manufacturer	Model	Serial Number	FCC ID
AC Adapter	Sunlin	MCS-02WR	RA471013501	NA
NA	NA	NA	NA	NA

I/O CABLES (CONDUCTED SETUP)

I/O Cable List						
Cable No	Port	# of identical ports	Connector Type	Cable Type	Cable Length (m)	Remarks
1	RF Out	1	Spectrum Analyzer	Shielded	None	NA
2	Antenna Port	1	EUT	Shielded	0.1m	NA
3	RF In/Out	1	Communication Test Set	Shielded	1m	NA

I/O CABLES (RADIATED SETUP)

I/O CABLE LIST						
Cable No.	Port	# of Identical Ports	Connector Type	Cable Type	Cable Length	Remarks
1	USB	1	AC Adapter	Un-shielded	1.2m	NA
2	Jack	1	Headset	Shielded	1m	NA
3	RF In/out	1	Communication Test Set	Un-shielded	2m	Yes

TEST SETUP

The EUT is continuously communicated to the call box during the tests.

SETUP DIAGRAM FOR TESTS (CONDUCTED TEST SETUP)

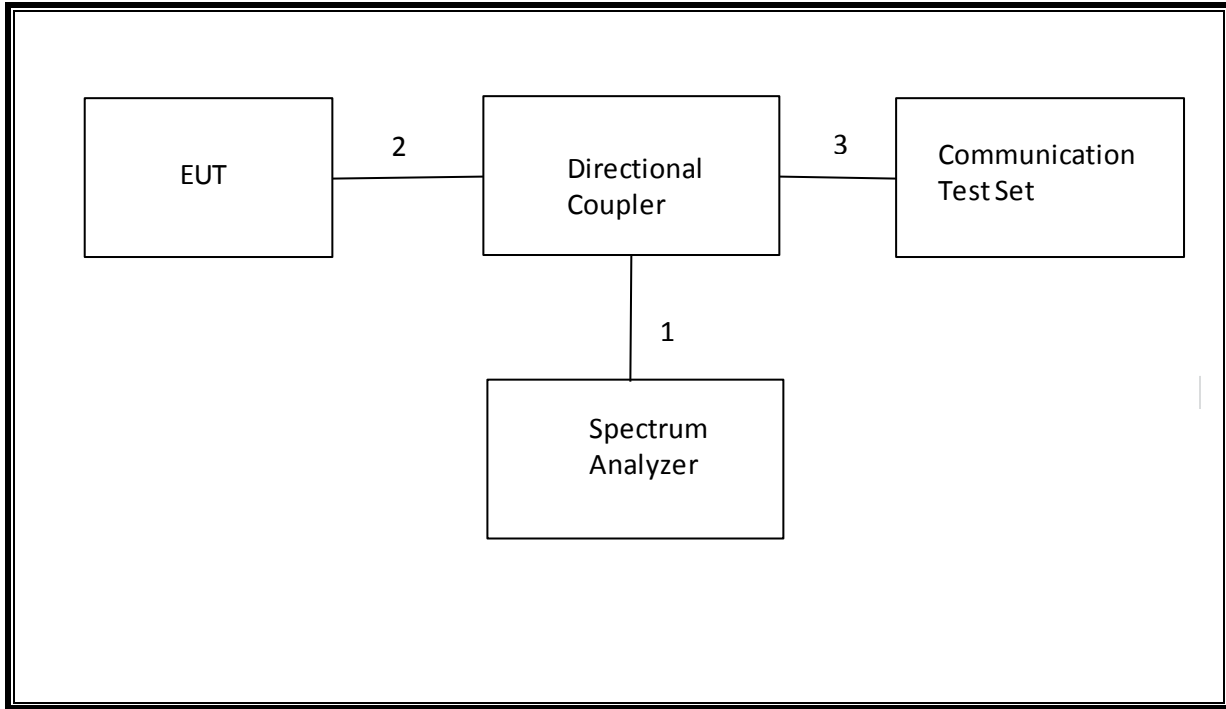

SETUP DIAGRAM FOR TESTS (RADIATED TEST SETUP)

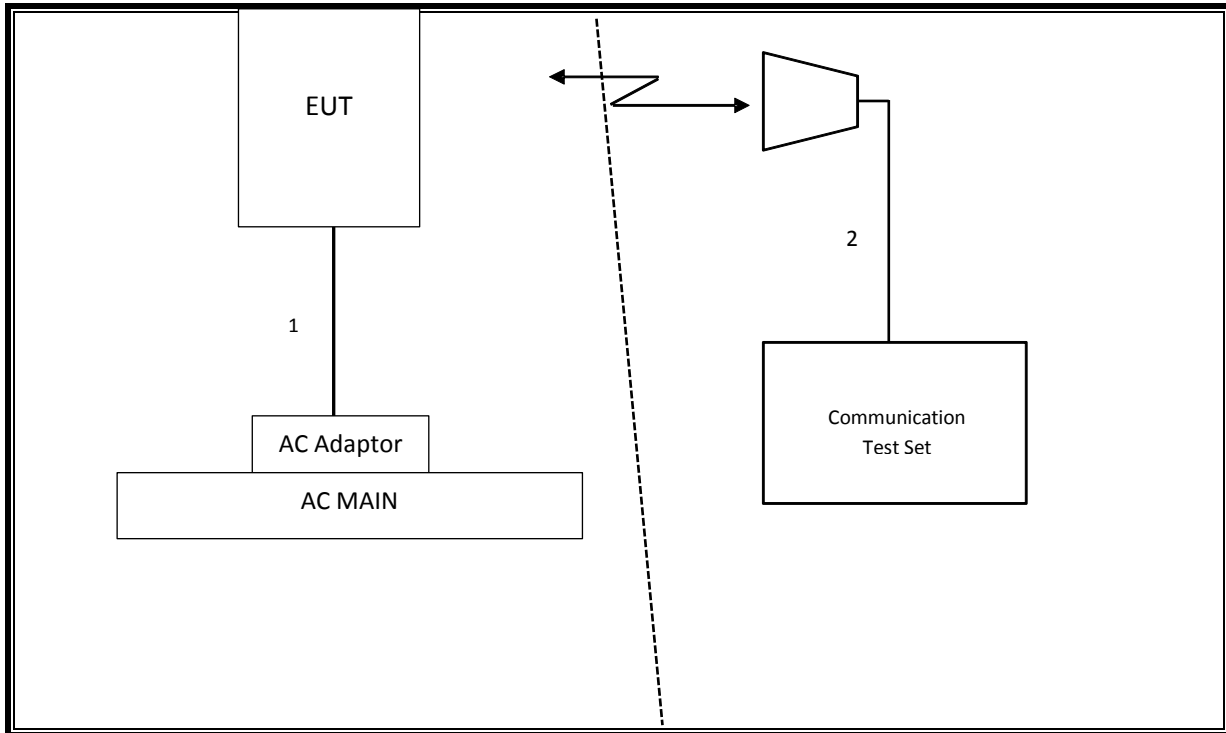

6. TEST AND MEASUREMENT EQUIPMENT

TEST EQUIPMENT LIST				
Description	Manufacturer	Model	Asset	Cal Due
Spectrum Analyzer, 44 GHz	Agilent / HP	E4446A	C01179	02/26/15
Antenna, Bilog, 2 GHz	Sunol Sciences	JB1	C01011	04/22/15
Antenna, Horn, 18 GHz	EMCO	3115	C00783	10/25/14
Antenna, Horn, 18 GHz	EMCO	3115	C00784	10/25/14
Highpass Filter, 2.7 GHz	Micro-Tronics	HPM13194	N02687	CNR
Highpass Filter, 1.5 GHz	Micro-Tronics	HPM13193	N02688	CNR
Temperature / Humidity Chamber	Thermotron	SE 600-10-10	C00930	01/09/15
Communications Test Set	R&S	CMW500	T159	07/02/15
DC power supply, 8 V @ 3 A or 15 V	Agilent / HP	E3610A	None	CNR
Vector signal generator, 6 GHz	Agilent / HP	E4438C	None	06/18/15
Antenna, Tuned Dipole 400~1000	ETS	3121C DB4	C00993	02/14/15
Directional Coupler	RF-Lambda	RFDC5M06G15	None	CNR
Antenna, Horn, 26.5 GHz	ARA	MWH-1826/B	C00589	12/17/14

The following test and measurement equipment was utilized for the tests documented in this report:

7. Summary Table

FCC Part Section	RSS Section(s)	Test Description	Test Limit	Test Condition	Test Result	Worst Case
2.1049	N/A	Occupied Band width (99%)	N/A	Conducted	Pass	1.29MHz
22.917(a) 24.238(a)	RSS-132(4.5.1) RSS-133(6.5.1) RSS-139(6.5.1)	Band Edge / Conducted Spurious Emission	-13dBm		Pass	-27.21dBm
2.1046	N/A	Conducted output power	N/A		Pass	24.50dBm
22.355 24.235	RSS-132(4.3) RSS-133(6.3)	Frequency Stability	2.5PPM		Pass	0.002PPM
22.913(a)(2)	RSS-132(4.4)	Effective Radiated Power	38.5 dBm	Radiated	Pass	25.59dBm
24.232(c)	RSS-133(6.4)	Equivalent Isotropic Radiated Power	33dBm		Pass	21.41dBm
22.917(a) 24.238(a)	RSS-132(4.5.1) RSS-133(6.5.1)	Radiated Spurious Emission	-13dBm		Pass	-43.10dBm

8.1.2. CDMA2000 OUTPUT POWER RESULT

Band	Mode	Ch	Freq. (MHz)	Avg Pwr (dBm)
BC0	RC1, SO55 (Loopback)	1013	824.70	24.5
		384	836.52	24.5
		777	848.31	24.5
	RC3, SO55 (Loopback)	1013	824.70	24.5
		384	836.52	24.5
		777	848.31	24.5
	RC3, SO32 (+F-SCH)	1013	824.70	24.5
		384	836.52	24.5
		777	848.31	24.5

Band	Mode	Ch	Freq. (MHz)	Avg Pwr (dBm)
BC1	RC1, SO55 (Loopback)	25	1851.25	21.2
		600	1880.00	21.2
		1175	1908.75	21.2
	RC3, SO55 (Loopback)	25	1851.25	21.2
		600	1880.00	21.2
		1175	1908.75	21.2
	RC3, SO32 (+F-SCH)	25	1851.25	21.2
		600	1880.00	21.2
		1175	1908.75	21.2

8.1.3. 1xEV-DO Release 0

TEST PROCEDURE

This procedure assumes the Agilent 8960 Test Set has the following applications installed and with valid license.

<u>Application</u>	<u>Rev, License</u>
1xEV-DO Terminal Test	A.09.13

EVDO Release 0 - RTAP

- Call Setup > Shift & Preset
- Call Control:
 - Access Network Info > Cell Parameters > Sector ID > 00000000 > Subnet Mask > 0
 - Generator Info > Termination Parameters > Max Forward Packet Duration > 16 Slots
- Call Params:
 - Cell Power > -105.5 dBm/1.23 MHz
 - Cell Band > (Select US Cellular or US PCS)
 - Channel > (Enter channel number)
 - Application Config > Enhanced Test Application Protocol > RTAP
 - RTAP Rate > 153.6 kbps
 - Rvs Power Ctrl > Active bits
 - Protocol Rel > 0 (1xEV-DO)
- Press "Start Data Connection" when "Session Open" appear in "Active Cell"
- Rvs Power Ctrl > All Up bits (Maximum TxPout)

EVDO Release 0 - FTAP

- Call Setup > Shift & Preset
- Call Control:
 - Access Network Info > Cell Parameters > Sector ID > 00000000 > Subnet Mask > 0
 - Generator Info > Termination Parameters > Max Forward Packet Duration > 16 Slots
- Call Params:
 - Cell Power > -105.5 dBm/1.23 MHz
 - Cell Band > (Select US Cellular or US PCS)
 - Channel > (Enter channel number)
 - Application Config > Enhanced Test Application Protocol > FTAP (default)
 - FTAP Rate > 307.2 kbps (2 Slot, QPSK)
 - Rvs Power Ctrl > Active bits
 - Protocol Rel > 0 (1xEV-DO)
- Press "Start Data Connection" when "Session Open" appear in "Active Cell"
- Rvs Power Ctrl > All Up bits (Maximum TxPout)

8.1.4. 1XEVD0 REL 0 OUTPUT POWER RESULT

NOT APPLICABLE

8.1.5. 1xEV-DO Rev. A

TEST PROCEDURE

This procedure assumes the Agilent 8960 Test Set has the following applications installed and with valid license.

<u>Application</u>	<u>Rev, License</u>
1xEV-DO Terminal Test	A.09.13

EVDO Release A – RETAP

- Call Setup > Shift & Preset
- Cell Power > -60 dBm/1.23 MHz
- Protocol Rev > A (1xEV-DO-A)
- Application Config > Enhanced Test Application Protocol > RETAP
- R-Data Pkt Size > 4096
- Protocol Subtype Config > Release A Physical Layer Subtype > Subtype 2
- > PL Subtype 2 Access Channel MAC Subtype > Default (Subtype 0)
- Access Network Info > Cell Parameters > Sector ID > 00000000 > Subnet Mask > 0
- Generator Info > Termination Parameters > Max Forward Packet Duration > 16 Slots > ACK R-Data After > Subpacket 0 (All ACK)
- Rvs Power Ctrl > All Up bits (to get the maximum power)

EVDO Release A - FETAP

- Call Setup > Shift & Preset
- Cell Power > -60 dBm/1.23 MHz
- Protocol Rev > A (1xEV-DO-A)
- Application Config > Enhanced Test Application Protocol > FETAP
- F-Traffic Format > 4 (1024, 2,128) Canonical (307.2k, QPSK)
- Protocol Subtype Config > Release A Physical Layer Subtype > Subtype 2
- > PL Subtype 2 Access Channel MAC Subtype > Default (Subtype 0)
- Access Network Info > Cell Parameters > Sector ID > 00000000 > Subnet Mask > 0
- Generator Info > Termination Parameters > Max Forward Packet Duration > 16 Slots > ACK R-Data After > Subpacket 0 (All ACK)
- Rvs Power Ctrl > All Up bits (to get the maximum power)

8.1.6. 1xEVDO REV A OUTPUT RESULT

NOT APPLICABLE

8.1.7. 1xEV-DO Rev. B

TEST PROCEDURE

This procedure assumes the Agilent 8960 Test Set has the following applications installed and with valid license.

<u>Application</u>	<u>Rev, License</u>
1xEV-DO Terminal Test	A.09.13

EVDO Release A – RETAP

- Call Setup > Shift & Preset
- Cell Power > -60 dBm/1.23 MHz
- Protocol Rev > A (1xEV-DO-A)
- Application Config > Enhanced Test Application Protocol > RETAP
- R-Data Pkt Size > 4096
- Protocol Subtype Config > Release A Physical Layer Subtype > Subtype 2
- > PL Subtype 2 Access Channel MAC Subtype > Default (Subtype 0)
- Access Network Info > Cell Parameters > Sector ID > 00000000 > Subnet Mask > 0
- Generator Info > Termination Parameters > Max Forward Packet Duration >16 Slots > ACK R-Data After > Subpacket 0 (All ACK)
- Rvs Power Ctrl > All Up bits (to get the maximum power)

EVDO Release A - FETAP

- Call Setup > Shift & Preset
- Cell Power > -60 dBm/1.23 MHz
- Protocol Rev > A (1xEV-DO-A)
- Application Config > Enhanced Test Application Protocol > FETAP
- F-Traffic Format > 4 (1024, 2,128) Canonical (307.2k, QPSK)
- Protocol Subtype Config > Release A Physical Layer Subtype > Subtype 2
- > PL Subtype 2 Access Channel MAC Subtype > Default (Subtype 0)
- Access Network Info > Cell Parameters > Sector ID > 00000000 > Subnet Mask > 0
- Generator Info > Termination Parameters > Max Forward Packet Duration >16 Slots > ACK R-Data After > Subpacket 0 (All ACK)
- Rvs Power Ctrl > All Up bits (to get the maximum power)

8.1.8. 1xEVDO REV B OUTPUT RESULT

NOT APPLICABLE

9. PEAK TO AVERAGE RATIO

Test Procedure

Per KDB 971168 D01 Power Meas License Digital Systems v02r01

Test Spec

In addition, when the transmitter power is measured in terms of average value, the peak-to-average ratio of the power shall not exceed 13 dB.

9.1. CONDUCTED PEAK TO AVERAGE RESULT

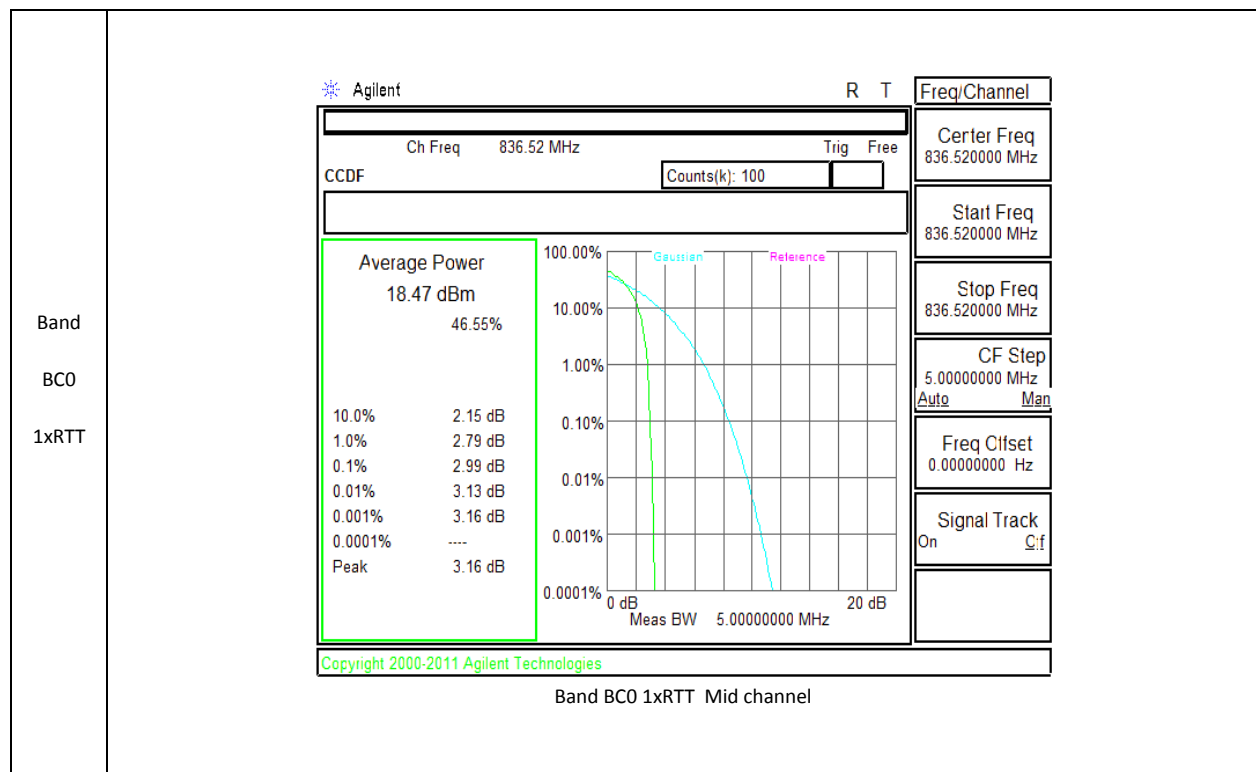

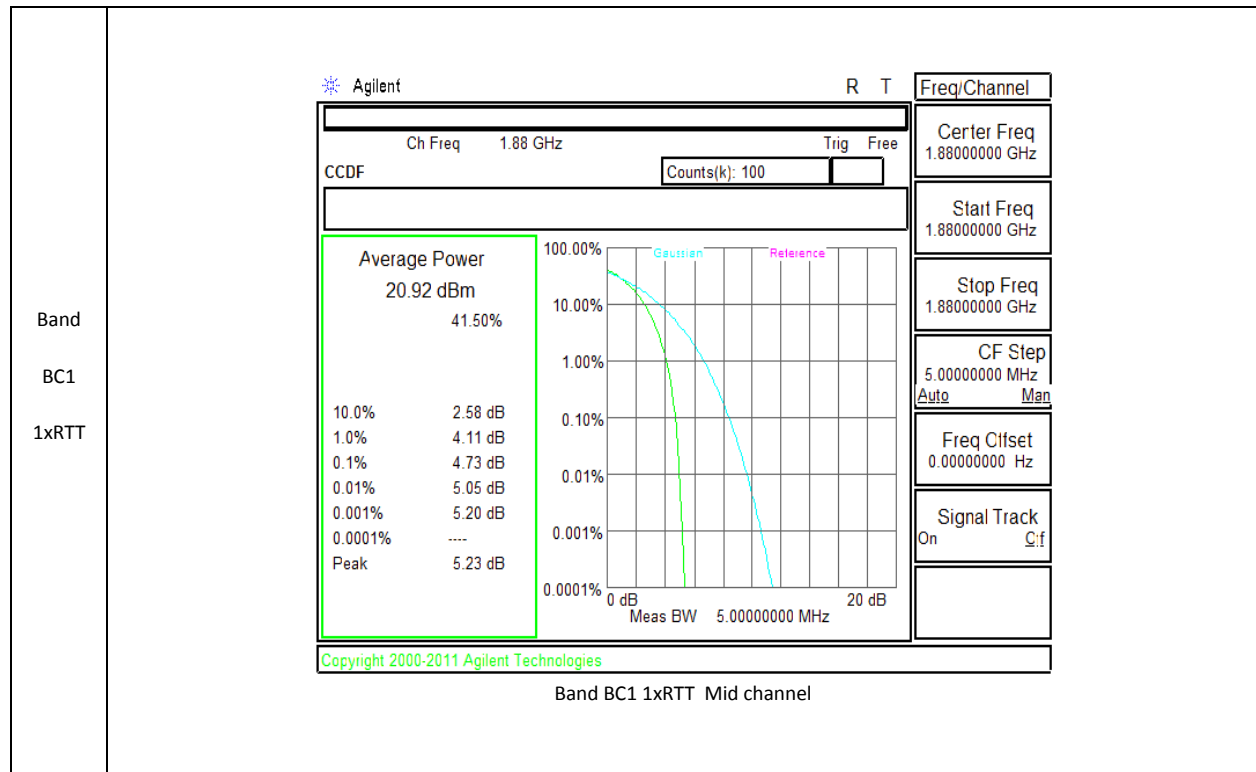

10. LIMITS AND CONDUCTED RESULTS

10.1. OCCUPIED BANDWIDTH

RULE PART(S)

FCC: §2.1049

LIMITS

For reporting purposes only

TEST PROCEDURE

The transmitter output was connected to a calibrated coaxial cable and coupler, the other end of which was connected to a spectrum analyzer. The occupied bandwidth was measured with the spectrum analyzer at the low, middle and high channel in each band. The -26dB bandwidth was also measured and recorded.

(KDB 971168 D01 Power Meas License Digital Systems v02r01 - 06/07/2013)

MODES TESTED

CDMA BC0, CDMA BC1

RESULTS

10.1.1. OCCUPIED BANDWIDTH RESULTS

Band	Mode	Channel	f (MHz)	99% BW (MHz)	-26dB BW (MHz)
BC0	1xRTT	1013	824.7	1.29	1.45
		384	836.52	1.29	1.48
		777	848.31	1.29	1.45
	EVDO REL. 0	1013	824.7		
		384	836.52		
		777	848.31		
	EVDO REV. A	1013	824.7		
		384	836.52		
		777	848.31		
BC1	1xRTT	25	1851.25	1.28	1.43
		600	1880	1.28	1.44
		1175	1908.75	1.28	1.42
	EVDO REL. 0	25	1851.25		
		600	1880		
		1175	1908.75		
	EVDO REV. A	25	1851.25		
		600	1880		
		1175	1908.75		

10.1.2. OCCUPIED BANDWIDTH PLOTS

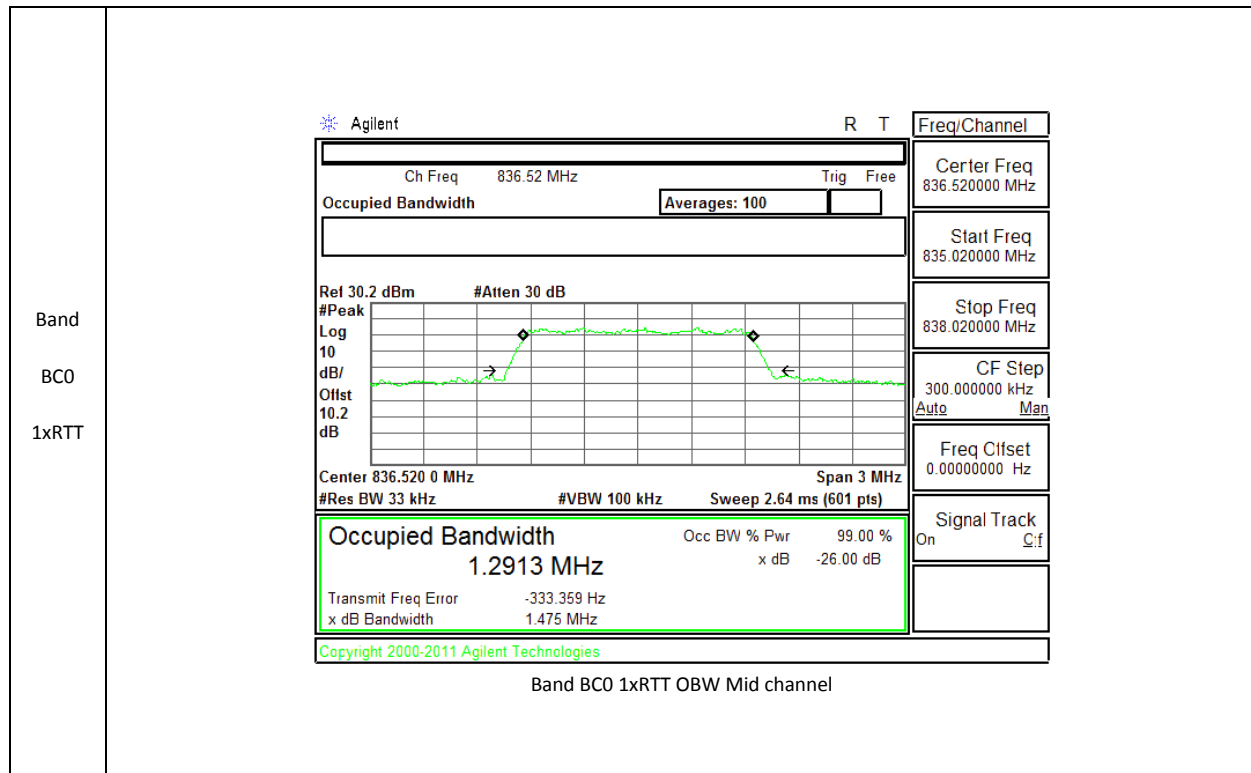

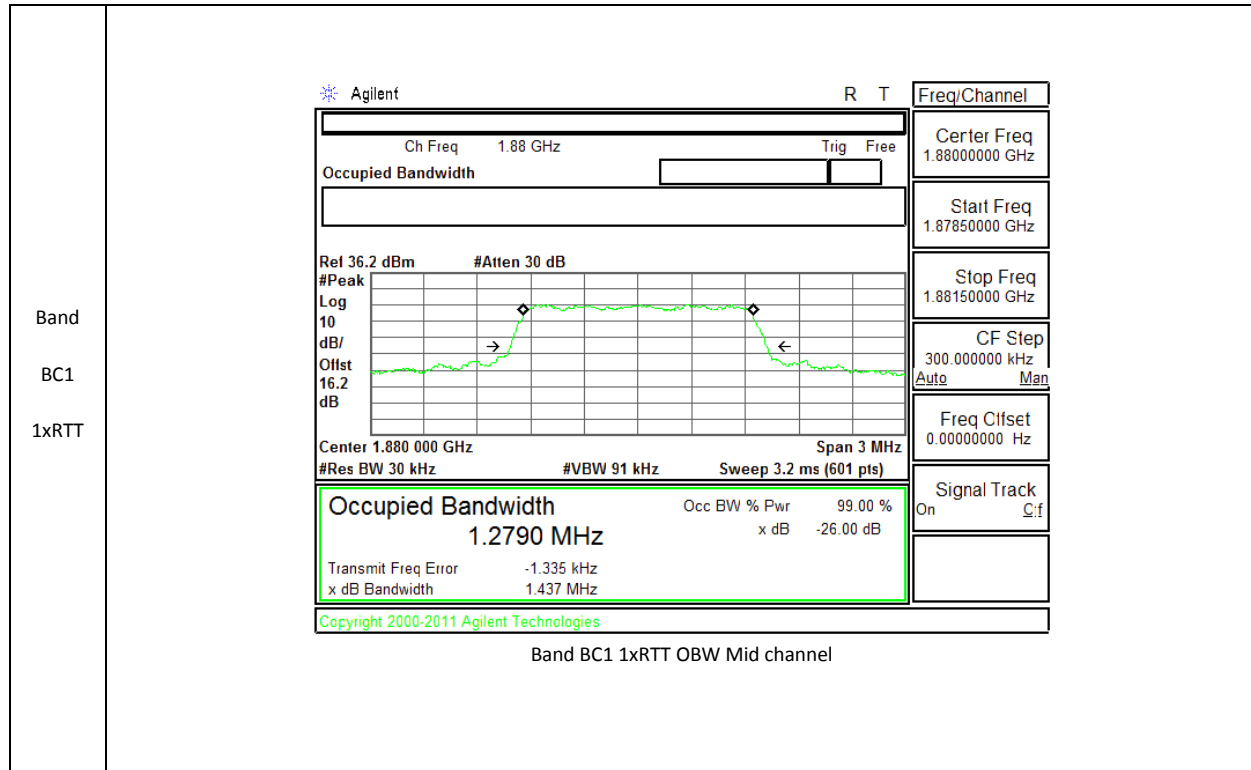

11. BAND EDGE EMISSIONS

RULE PART(S)

FCC: §22.359, §24.238

LIMITS

The power of any emission outside of the authorized operating frequency ranges must be attenuated below the transmitting power (P) by a factor of at least $43 + 10 \log (P)$ dB.

TEST PROCEDURE

Per KDB 971168 D01 Power Meas License Digital Systems v02r01

The transmitter output was connected to an Agilent 8960 or a CMW500 Test Set and configured to operate at maximum power. The band edge emissions were measured at the required operating frequencies in each band on the Spectrum Analyzer.

MODES TESTED

CDMA BC0, CDMA BC1

RESULTS

11.1. BAND EDGE PLOTS

CDMA BC0



CDMA BC1

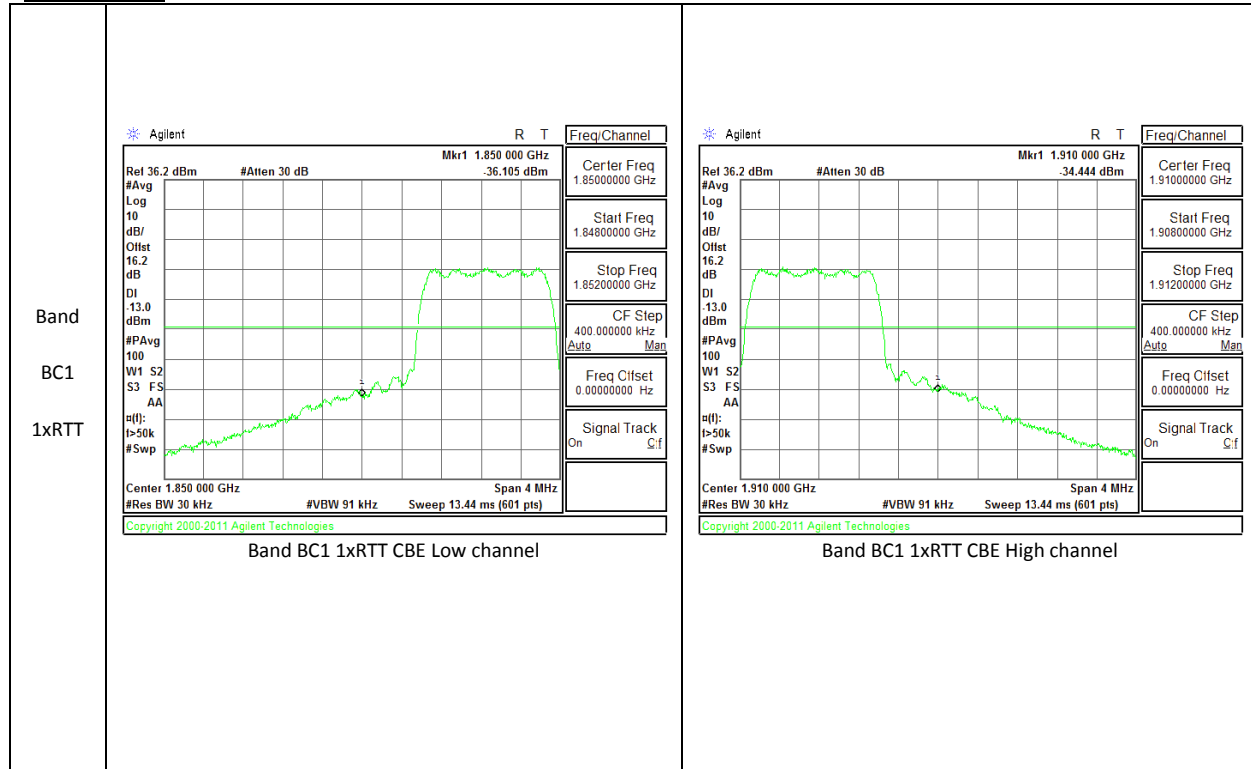

12. OUT OF BAND EMISSIONS

RULE PART(S)

FCC: §2.1051, §22.901, §22.917, §24.238

LIMITS

The power of any emission outside of the authorized operating frequency ranges must be attenuated below the transmitting power (P) by a factor of at least $43 + 10 \log (P)$ dB.

TEST PROCEDURE

Per KDB 971168 D01 Power Meas License Digital Systems v02r01

The RF output of the transmitter was connected to a spectrum analyzer through a calibrated coaxial cable. Sufficient scans were taken to show the out-of-band Emissions, if any, up to 10th harmonic. Multiple sweeps were recorded in maximum hold mode using a peak detector to ensure that the worst-case emissions were caught.

MODES TESTED

CDMA BC0, CDMA BC1

RESULTS

12.1. OUT OF BAND EMISSIONS RESULT

Band	Mode	f (MHz)	Spur (dBm)	Spec (dBm)	Delta (dB)
BC0	1xRTT	824.7	-27.87	-13	-14.87
		836.52	-27.24	-13	-14.24
		848.31	-28.10	-13	-15.10
BC1	1xRTT	1851.25	-27.94	-13	-14.94
		1880	-27.21	-13	-14.21
		1908.75	-27.84	-13	-14.84

12.2. OUT OF BAND EMISSIONS PLOTS

CDMA BC0

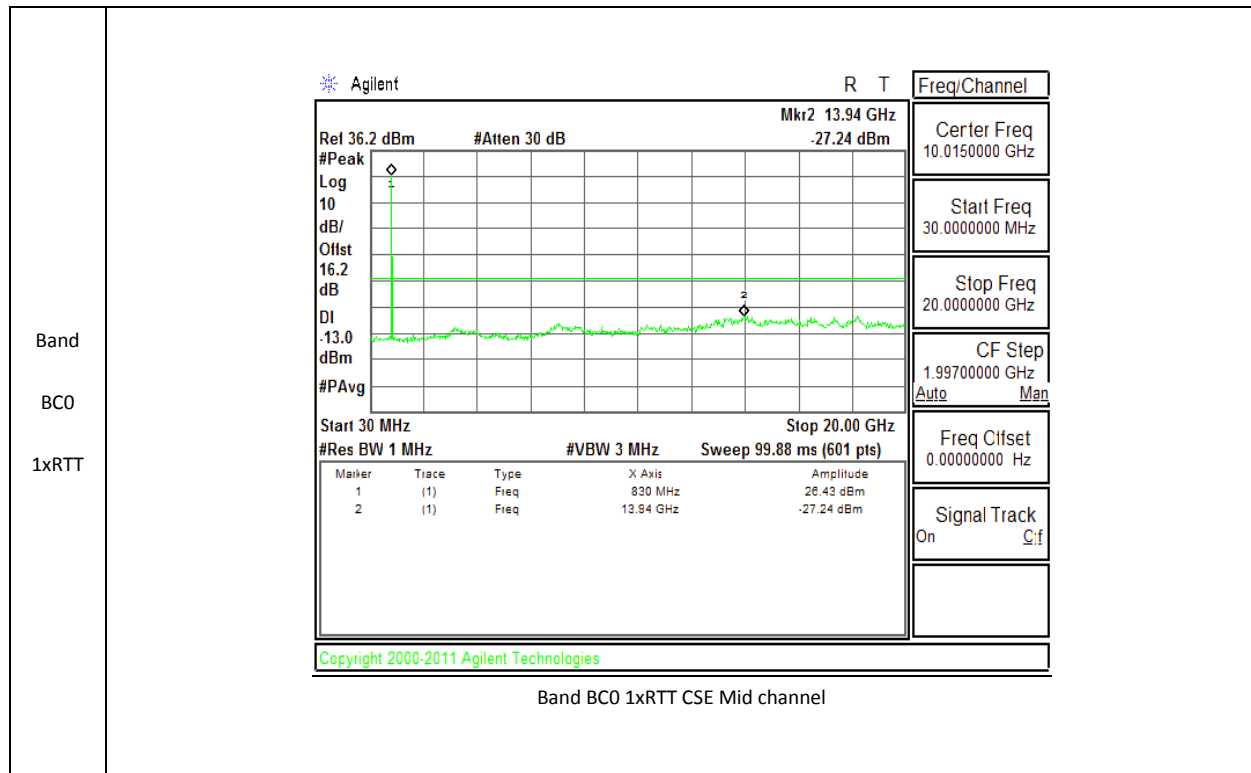

CDMA BC1

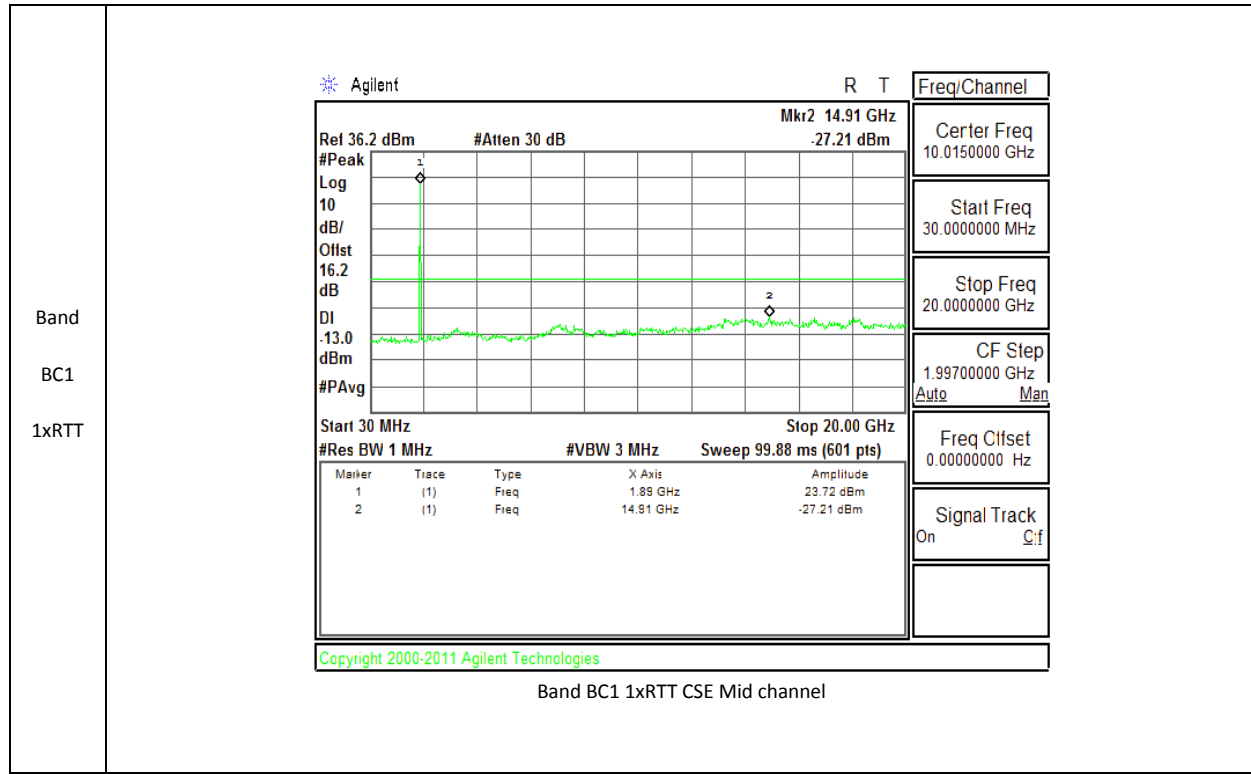

13. FREQUENCY STABILITY

RULE PART(S)

FCC: §2.1055, §22.355, §24.235

LIMITS

§22.355 - The carrier frequency shall not depart from the reference frequency in excess of ± 2.5 ppm for mobile stations.

§24.235 - The frequency stability shall be sufficient to ensure that the fundamental emission stays within the authorized frequency block.

TEST PROCEDURE

Per KDB 971168 D01 Power Meas License Digital Systems v02r01

MODES TESTED

CDMA BC0, CDMA BC1

RESULTS

See the following pages.

13.1. FREQUENCY STABILITY RESULTS

CELL, CDMA MODULATION – MID CHANNEL BCO

Reference Frequency: Cellular Mid Channel 836.520001MHz @ 20°C Limit: to stay +/- 2.5 ppm = 2091.300 Hz				
Power Supply (Vdc)	Environment Temperature (°C)	Frequency Deviation Measured with Time Elapse		
		(MHz)	Delta (ppm)	Limit (ppm)
3.80	50	836.520019	-0.042	2.5
3.80	40	836.520015	-0.037	2.5
3.80	30	836.519987	-0.004	2.5
3.80	20	836.519984	0	2.5
3.80	10	836.519985	-0.001	2.5
3.80	0	836.519987	-0.004	2.5
3.80	-10	836.519983	0.001	2.5
3.80	-20	836.519982	0.002	2.5
3.80	-30	836.519982	0.002	2.5

Reference Frequency: Cellular Mid Channel 836.520001MHz @ 20°C Limit: to stay +/- 2.5 ppm = 2091.300 Hz				
Power Supply (Vdc)	Environment Temperature (°C)	Frequency Deviation Measured with Time Elapse		
		(MHz)	Delta (ppm)	Limit (ppm)
3.80	20	836.519984	0	2.5
4.30	20	836.519986	-0.002	2.5
3.40	20	836.519987	-0.004	2.5

PCS, CDMA MODULATION – MID CHANNEL BC1

(Vdc)	Temperature (*C)	(MHz)	Delta (ppm)	Limit (ppm)
3.80	50	1880.000008	-0.009	2.5
3.80	40	1880.000006	-0.007	2.5
3.80	30	1879.999991	0.001	2.5
3.80	20	1879.999992	0	2.5
3.80	10	1879.999993	-0.001	2.5
3.80	0	1879.999993	-0.001	2.5
3.80	-10	1880.000007	-0.008	2.5
3.80	-20	1880.000008	-0.009	2.5
3.80	-30	1880.000009	-0.009	2.5

Reference Frequency: PCS Mid Channel 1880.000004MHz @ 20°C				
Limit: within the authorized block or +/- 2.5 ppm = 4700.000 Hz				
Power Supply (Vdc)	Environment Temperature (*C)	Frequency Deviation Measured with Time Elapse		
		(MHz)	Delta (ppm)	Limit (ppm)
3.80	20	1879.999992	0.00000	2.5
4.30	20	1879.999994	-0.00106	2.5
3.40	20	1879.999996	-0.00213	2.5

14. RADIATED TEST RESULTS

14.1. RADIATED POWER (ERP & EIRP)

RULE PART(S)

FCC: §2.1046, §22.913, §24.232

LIMITS

22.913(a) - The ERP of mobile transmitters and auxiliary test transmitters must not exceed 7 Watts.

24.232(c) - Mobile/portable stations are limited to 2 watts e.i.r.p. peak power and the equipment must employ means to limit the power to the minimum necessary for successful communications.

In addition, when the transmitter power is measured in terms of average value, the peak-to-average ratio of the power shall not exceed 13dB.

TEST PROCEDURE

ANSI / TIA / EIA 603C Clause 2.2.17; PSA setting reference to 971168 D01 v02r01

For peak power measurement with a PSA:

a) Set the RBW \geq OBW; b) Set VBW $\geq 3 \times$ RBW; c) Set span $\geq 2 \times$ RBW; d) Sweep time = auto couple; e) Detector = peak; f) Ensure that the number of measurement points \geq span/RBW; g) Trace mode = max hold;

MODES TESTED

CDMA BC0, CDMA BC1

TEST RESULTS

14.1.1. ERP/EIRP Results

CDMA BC0

Band	Mode	Channel	f(MHz)	ERP	
				dBm	mW
BC0	1xRTT	1013	824.7	24.923	310.67
		384	836.52	25.585	361.83
		777	848.31	25.232	333.58
	EVDO REL. 0	1013	824.7		
		384	836.52		
		777	848.31		
	EVDO REV. A	1013	824.7		
		384	836.52		
		777	848.31		

CDMA BC1

Band	Mode	Channel	f(MHz)	EIRP	
				dBm	mW
BC1	1xRTT	25	1851.25	20.515	112.59
		600	1880	20.601	114.84
		1175	1908.75	21.410	138.36
	EVDO REL. 0	25	1851.25		
		600	1880		
		1175	1908.75		
	EVDO REV. A	25	1851.25		
		600	1880		
		1175	1908.75		

14.1.2. ERP/EIRP PLOTS

Band BC0 1xRTT	High Frequency Substitution Measurement UL Verification Services, Inc. Chamber B								
	Company: LG								
	Project #: 14U18513								
	Date: 08/28/14								
	Test Engineer: T.Oeur								
	Configuration: EUT w/Charger								
	Mode: CDMA RTT BC0								
	Test Equipment: Receiving: Sunoi T185, and 3m Chamber N-type Cable (Setup this one for testing EUT) Substitution: Dipole S/N: 00022117, 4ft SMA Cable (SN # 245200 001) Warehouse.								
	f MHz	SG reading (dBm)	Ant. Pol. (H/V)	Cable Loss (dB)	Antenna Gain (dBd)	ERP (dBm)	Limit (dBm)	Margin (dB)	Notes
	Low Ch								
824.70	20.92	V	0.5	0.0	20.42	38.5	-18.0		
824.70	25.42	H	0.5	0.0	24.92	38.5	-13.5		
Mid Ch									
836.52	21.18	V	0.5	0.0	20.68	38.5	-17.8		
836.52	26.08	H	0.5	0.0	25.59	38.5	-12.9		
High Ch									
848.31	19.88	V	0.5	0.0	19.38	38.5	-19.1		
848.31	25.73	H	0.5	0.0	25.23	38.5	-13.2		
Rev. 3.17.11 Note: For Band 13/17 ERP limit is 34.77dBm; For Band 26 limit is 50dBm									

Band BC1 1xRTT	High Frequency Substitution Measurement UL Verification Services, Inc. Chamber B																																																																																																					
	Company:		LG																																																																																																			
	Project #:		14U18513																																																																																																			
	Date:		08/29/14																																																																																																			
	Test Engineer:		G. Chan																																																																																																			
	Configuration:		EUT w/Charger																																																																																																			
	Mode:		CDMA RTT BC1																																																																																																			
	Test Equipment:																																																																																																					
	Receiving:		Horn T119, and Chamber B SMA Cables																																																																																																			
	Substitution:		Horn T59 Substitution, 4ft SMA Cable Warehouse																																																																																																			
<table border="1"> <thead> <tr> <th>f MHz</th> <th>SG reading (dBm)</th> <th>Ant. Pol. (H/V)</th> <th>Cable Loss (dB)</th> <th>Antenna Gain (dBi)</th> <th>EIRP (dBm)</th> <th>Limit (dBm)</th> <th>Margin (dB)</th> <th>Notes</th> </tr> </thead> <tbody> <tr> <td colspan="10">Low Ch</td> </tr> <tr> <td>1851.25</td> <td>7.95</td> <td>V</td> <td>0.9</td> <td>9.7</td> <td>16.75</td> <td>33.0</td> <td>-16.2</td> <td></td> </tr> <tr> <td>1851.25</td> <td>11.72</td> <td>H</td> <td>0.9</td> <td>9.7</td> <td>20.52</td> <td>33.0</td> <td>-12.5</td> <td></td> </tr> <tr> <td colspan="10">Mid Ch</td> </tr> <tr> <td>1880.00</td> <td>8.10</td> <td>V</td> <td>0.9</td> <td>9.7</td> <td>16.90</td> <td>33.0</td> <td>-16.1</td> <td></td> </tr> <tr> <td>1880.00</td> <td>11.80</td> <td>H</td> <td>0.9</td> <td>9.7</td> <td>20.60</td> <td>33.0</td> <td>-12.4</td> <td></td> </tr> <tr> <td colspan="10">High Ch</td> </tr> <tr> <td>1908.75</td> <td>7.93</td> <td>V</td> <td>0.9</td> <td>11.3</td> <td>18.33</td> <td>33.0</td> <td>-14.7</td> <td></td> </tr> <tr> <td>1908.75</td> <td>11.01</td> <td>H</td> <td>0.9</td> <td>11.3</td> <td>21.41</td> <td>33.0</td> <td>-11.6</td> <td></td> </tr> </tbody> </table>										f MHz	SG reading (dBm)	Ant. Pol. (H/V)	Cable Loss (dB)	Antenna Gain (dBi)	EIRP (dBm)	Limit (dBm)	Margin (dB)	Notes	Low Ch										1851.25	7.95	V	0.9	9.7	16.75	33.0	-16.2		1851.25	11.72	H	0.9	9.7	20.52	33.0	-12.5		Mid Ch										1880.00	8.10	V	0.9	9.7	16.90	33.0	-16.1		1880.00	11.80	H	0.9	9.7	20.60	33.0	-12.4		High Ch										1908.75	7.93	V	0.9	11.3	18.33	33.0	-14.7		1908.75	11.01	H	0.9	11.3	21.41	33.0	-11.6	
f MHz	SG reading (dBm)	Ant. Pol. (H/V)	Cable Loss (dB)	Antenna Gain (dBi)	EIRP (dBm)	Limit (dBm)	Margin (dB)	Notes																																																																																														
Low Ch																																																																																																						
1851.25	7.95	V	0.9	9.7	16.75	33.0	-16.2																																																																																															
1851.25	11.72	H	0.9	9.7	20.52	33.0	-12.5																																																																																															
Mid Ch																																																																																																						
1880.00	8.10	V	0.9	9.7	16.90	33.0	-16.1																																																																																															
1880.00	11.80	H	0.9	9.7	20.60	33.0	-12.4																																																																																															
High Ch																																																																																																						
1908.75	7.93	V	0.9	11.3	18.33	33.0	-14.7																																																																																															
1908.75	11.01	H	0.9	11.3	21.41	33.0	-11.6																																																																																															
Rev. 3.17.11																																																																																																						
Note: For Band 4 EIRP limit is 30dBm																																																																																																						

15. FIELD STRENGTH OF SPURIOUS RADIATION

RULE PART(S)

FCC: §2.1053, §22.917, §24.238

LIMIT

The power of any emission outside of the authorized operating frequency ranges must be attenuated below the transmitting power (P) by a factor of at least $43 + 10 \log (P)$ dB.

TEST PROCEDURE

For Cellular equipment - Compliance with these rules is based on the use of measurement instrumentation employing a resolution bandwidth of 100 kHz or greater. In the 1 MHz bands immediately outside and adjacent to the frequency block a resolution bandwidth of at least one percent of the emission bandwidth of the fundamental emission of the transmitter may be employed. A narrower resolution bandwidth is permitted in all cases to improve measurement accuracy provided the measured power is integrated over the full required measurement bandwidth (i.e. 100 kHz or 1 percent of emission bandwidth, as specified). The emission bandwidth is defined as the width of the signal between two points, one below the carrier center frequency and one above the carrier center frequency, outside of which all emissions are attenuated at least 26 dB below the transmitter power.

For PCS equipment - Compliance with these rules is based on the use of measurement instrumentation employing a resolution bandwidth of 1 MHz or greater. However, in the 1 MHz bands immediately outside and adjacent to the frequency block a resolution bandwidth of at least one percent of the emission bandwidth of the fundamental emission of the transmitter may be employed. A narrower resolution bandwidth is permitted in all cases to improve measurement accuracy provided the measured power is integrated over the full required measurement bandwidth (i.e. 1 MHz or 1 percent of emission bandwidth, as specified). The emission bandwidth is defined as the width of the signal between two points, one below the carrier center frequency and one above the carrier center frequency, outside of which all emissions are attenuated at least 26 dB below the transmitter power.

MODES TESTED

CDMA BC0, CDMA BC1

RESULTS

15.1. SPURIOUS RADIATION PLOTS

Compliance Certification Services										
Above 1GHz High Frequency Substitution Measurement										
Company:		LG								
Project #:		14U18513								
Date:		08/29/14								
Test Engineer:		G. Chan								
Configuration:		EUT w/Charger								
Mode:		CDMA RTT BC0								
Chamber		Pre-amplifier			Filter		Limit			
5m Chamber B		T34 8449B			Filter 1		Part 22			
f GHz	SG reading (dBm)	Ant. Pol. (H/V)	Distance (m)	Preamp (dB)	Filter (dB)	EIRP (dBm)	Limit (dBm)	Delta (dB)	Notes	
Band										
BC0										
1xRTT										
Low Ch, 824.7MHz										
1.649	-23.0	V	3.0	37.4	1.0	-59.4	-13.0	-46.4		
2.474	-23.7	V	3.0	36.4	1.0	-59.1	-13.0	-46.1		
3.299	-21.7	V	3.0	35.8	1.0	-56.5	-13.0	-43.5		
1.649	-23.9	H	3.0	37.4	1.0	-60.3	-13.0	-47.3		
2.474	-23.2	H	3.0	36.4	1.0	-58.6	-13.0	-45.6		
3.299	-22.2	H	3.0	35.8	1.0	-57.0	-13.0	-44.0		
Mid Ch, 836.52MHz										
1.673	-22.7	V	3.0	37.3	1.0	-59.0	-13.0	-46.0		
2.510	-20.9	V	3.0	36.4	1.0	-56.2	-13.0	-43.2		
3.346	-22.0	V	3.0	35.8	1.0	-56.7	-13.0	-43.7		
1.673	-25.2	H	3.0	37.3	1.0	-61.5	-13.0	-48.5		
2.510	-23.4	H	3.0	36.4	1.0	-58.8	-13.0	-45.8		
3.346	-21.9	H	3.0	35.8	1.0	-56.7	-13.0	-43.7		
High Ch, 848.31MHz										
1.697	-28.2	V	3.0	37.3	1.0	-64.5	-13.0	-51.5		
2.545	-19.9	V	3.0	36.3	1.0	-55.2	-13.0	-42.2		
3.393	-20.8	V	3.0	35.7	1.0	-55.5	-13.0	-42.5		
1.697	-24.7	H	3.0	37.3	1.0	-61.0	-13.0	-48.0		
2.545	-21.0	H	3.0	36.3	1.0	-56.3	-13.0	-43.3		
3.393	-20.9	H	3.0	35.7	1.0	-55.6	-13.0	-42.6		
Rev. 03.03.09										
Note: No other emissions were detected above the system noise floor.										

Compliance Certification Services Above 1GHz High Frequency Substitution Measurement										
Company:		LG								
Project #:		14U18513								
Date:		08/29/14								
Test Engineer:		G. Chan								
Configuration:		EUT w/Charger								
Mode:		CDMA RTT BC1								
Chamber		Pre-amplifer			Filter		Limit			
5m Chamber B		T34 8449B			Filter 1		Part 24			
Band	f GHz	SG reading (dBm)	Ant. Pol. (H/V)	Distance (m)	Preamp (dB)	Filter (dB)	EIRP (dBm)	Limit (dBm)	Delta (dB)	Notes
	Low Ch, 1851.25MHz									
	3.703	-16.6	V	3.0	35.4	1.0	-51.0	-13.0	-38.0	
	5.554	-15.4	V	3.0	34.7	1.0	-49.1	-13.0	-36.1	
	7.405	-9.2	V	3.0	34.9	1.0	-43.1	-13.0	-30.1	
	Mid Ch, 1880.00MHz									
	3.703	-16.8	H	3.0	35.4	1.0	-51.2	-13.0	-38.2	
	5.554	-14.8	H	3.0	34.7	1.0	-48.5	-13.0	-35.5	
	7.405	-12.4	H	3.0	34.9	1.0	-46.3	-13.0	-33.3	
	High Ch, 1908.75MHz									
	3.760	-14.4	V	3.0	35.3	1.0	-48.8	-13.0	-35.8	
	5.640	-13.3	V	3.0	34.7	1.0	-47.0	-13.0	-34.0	
	7.520	-12.3	V	3.0	34.9	1.0	-46.3	-13.0	-33.3	
	3.760	-14.2	H	3.0	35.3	1.0	-48.6	-13.0	-35.6	
	5.640	-14.5	H	3.0	34.7	1.0	-48.2	-13.0	-35.2	
	7.520	-11.4	H	3.0	34.9	1.0	-45.3	-13.0	-32.3	
	High Ch, 1908.75MHz									
	3.818	-13.5	V	3.0	35.3	1.0	-47.7	-13.0	-34.7	
	5.726	-14.1	V	3.0	34.7	1.0	-47.8	-13.0	-34.8	
	7.635	-11.7	V	3.0	34.9	1.0	-45.7	-13.0	-32.7	
	3.818	-16.3	H	3.0	35.3	1.0	-50.6	-13.0	-37.6	
	5.726	-11.1	H	3.0	34.7	1.0	-44.9	-13.0	-31.9	
	7.635	-9.2	H	3.0	34.9	1.0	-43.2	-13.0	-30.2	
Rev. 03.03.09										
Note: No other emissions were detected above the system noise floor.										