



MEASUREMENT REPORT FCC Part 22, 24, & 27 LTE

Applicant Name:
 LG Electronics MobileComm U.S.A
 1000 Sylvan Avenue
 Englewood Cliffs, NJ 07632
 United States

Date of Testing:
 7/20-7/26/2015
Test Site/Location:
 PCTEST Lab., Columbia, MD, USA
Test Report Serial No.:
 0Y1507241429.ZNF

FCC ID :	ZNFV930
APPLICANT:	LG ELECTRONICS MOBILECOMM U.S.A

Application Type: Class II Permissive Change
FCC Classification: PCS Licensed Transmitter (PCB)
FCC Rule Part(s): §2; §22; §24; §27
Test Procedure(s): ANSI/TIA-603-C-2004, KDB 971168 v02r02
EUT Type: Portable Tablet
Model(s): LG-V930, LGV930, V930
Test Device Serial No.: *identical prototype* [S/N: 351895070010580]
Class II Permissive Change: Please see FCC change document
Original Grant Date: 7/27/2015

Mode	Tx Frequency (MHz)	Modulation	ERP/EIRP		Mode	Tx Frequency (MHz)	Modulation	EIRP	
			Max. Power (W)	Max. Power (dBm)				Max. Power (W)	Max. Power (dBm)
LTE Band 12	699.7 - 715.3	QPSK	0.050	16.96	LTE Band 4	1717.5 - 1747.5	QPSK	0.457	26.60
LTE Band 12	699.7 - 715.3	16QAM	0.056	17.48	LTE Band 4	1717.5 - 1747.5	16QAM	0.352	25.46
LTE Band 12	700.5 - 714.5	QPSK	0.067	18.24	LTE Band 4	1720 - 1745	QPSK	0.400	26.02
LTE Band 12	700.5 - 714.5	16QAM	0.073	18.65	LTE Band 4	1720 - 1745	16QAM	0.320	25.05
LTE Band 12/17	701.5 - 713.5	QPSK	0.056	17.44	LTE Band 2	1850.7 - 1909.3	QPSK	0.336	25.27
LTE Band 12/17	701.5 - 713.5	16QAM	0.043	16.30	LTE Band 2	1850.7 - 1909.3	16QAM	0.253	24.04
LTE Band 12/17	704 - 711	QPSK	0.043	16.33	LTE Band 2	1851.5 - 1908.5	QPSK	0.406	26.09
LTE Band 12/17	704 - 711	16QAM	0.033	15.18	LTE Band 2	1851.5 - 1908.5	16QAM	0.304	24.83
LTE Band 5	824.7 - 848.3	QPSK	0.351	25.46	LTE Band 2	1852.5 - 1907.5	QPSK	0.418	26.21
LTE Band 5	824.7 - 848.3	16QAM	0.278	24.44	LTE Band 2	1852.5 - 1907.5	16QAM	0.321	25.06
LTE Band 5	825.5 - 847.5	QPSK	0.337	25.27	LTE Band 2	1855 - 1905	QPSK	0.371	25.70
LTE Band 5	825.5 - 847.5	16QAM	0.258	24.12	LTE Band 2	1855 - 1905	16QAM	0.283	24.52
LTE Band 5	826.5 - 846.5	QPSK	0.260	24.15	LTE Band 2	1857.5 - 1902.5	QPSK	0.418	26.21
LTE Band 5	826.5 - 846.5	16QAM	0.204	23.10	LTE Band 2	1857.5 - 1902.5	16QAM	0.319	25.04
LTE Band 5	829 - 844	QPSK	0.360	25.56	LTE Band 2	1860 - 1900	QPSK	0.361	25.57
LTE Band 5	829 - 844	16QAM	0.283	24.51	LTE Band 2	1860 - 1900	16QAM	0.273	24.35
LTE Band 4	1710.7 - 1754.3	QPSK	0.342	25.34	LTE Band 7	2502.5 - 2567.5	QPSK	0.071	18.54
LTE Band 4	1710.7 - 1754.3	16QAM	0.265	24.24	LTE Band 7	2502.5 - 2567.5	16QAM	0.053	17.28
LTE Band 4	1711.5 - 1753.5	QPSK	0.459	26.62	LTE Band 7	2505 - 2565	QPSK	0.114	20.57
LTE Band 4	1711.5 - 1753.5	16QAM	0.368	25.66	LTE Band 7	2505 - 2565	16QAM	0.085	19.29
LTE Band 4	1712.5 - 1752.5	QPSK	0.462	26.65	LTE Band 7	2507.5 - 2562.5	QPSK	0.114	20.56
LTE Band 4	1712.5 - 1752.5	16QAM	0.349	25.43	LTE Band 7	2507.5 - 2562.5	16QAM	0.087	19.39
LTE Band 4	1715 - 1750	QPSK	0.476	26.77	LTE Band 7	2510 - 2560	QPSK	0.097	19.87
LTE Band 4	1715 - 1750	16QAM	0.371	25.69	LTE Band 7	2510 - 2560	16QAM	0.075	18.75

This equipment has been shown to be capable of compliance with the applicable technical standards as indicated in the measurement report and was tested in accordance with the measurement procedures specified in §2.947. Test results reported herein relate only to the item(s) tested.

I attest to the accuracy of data. All measurements reported herein were performed by me or were made under my supervision and are correct to the best of my knowledge and belief. I assume full responsibility for the completeness of these measurements and vouch for the qualifications of all persons taking them.



Randy Ortañez
 President



FCC ID: ZNFV930		FCC Pt. 22, 24, & 27 LTE MEASUREMENT REPORT (CLASS II PERMISSIVE CHANGE)		Reviewed by: Quality Manager
Test Report S/N: 0Y1507241429.ZNF	Test Dates: 7/20-7/26/2015	EUT Type: Portable Tablet		Page 1 of 29

T A B L E O F C O N T E N T S

FCC PART 22, 24, & 27 MEASUREMENT REPORT		3
1.0 INTRODUCTION		4
1.1 SCOPE		4
1.2 TESTING FACILITY		4
2.0 PRODUCT INFORMATION		5
2.1 EQUIPMENT DESCRIPTION		5
2.2 DEVICE CAPABILITIES		5
2.3 TEST CONFIGURATION		5
2.4 EMI SUPPRESSION DEVICE(S)/MODIFICATIONS		5
3.0 DESCRIPTION OF TESTS		6
3.1 MEASUREMENT PROCEDURE		6
3.2 BLOCK A FREQUENCY RANGE		6
3.3 CELLULAR - BASE FREQUENCY BLOCKS		6
3.4 CELLULAR - MOBILE FREQUENCY BLOCKS		6
3.5 PCS - BASE FREQUENCY BLOCKS		7
3.6 PCS - MOBILE FREQUENCY BLOCKS		7
3.7 AWS - BASE FREQUENCY BLOCKS		7
3.8 AWS - MOBILE FREQUENCY BLOCKS		7
3.9 BRS/EBS FREQUENCY BLOCK		8
3.10 RADIATED POWER AND RADIATED SPURIOUS EMISSIONS		9
4.0 TEST EQUIPMENT CALIBRATION DATA		10
5.0 SAMPLE CALCULATIONS		11
6.0 TEST RESULTS		12
6.1 SUMMARY		12
6.2 RADIATED POWER (ERP/EIRP)		13
6.3 RADIATED SPURIOUS EMISSIONS MEASUREMENTS		20
7.0 CONCLUSION		29

FCC ID: ZNFV930		FCC Pt. 22, 24, & 27 LTE MEASUREMENT REPORT (CLASS II PERMISSIVE CHANGE)		Reviewed by: Quality Manager
Test Report S/N: 0Y1507241429.ZNF	Test Dates: 7/20-7/26/2015	EUT Type: Portable Tablet		Page 2 of 29

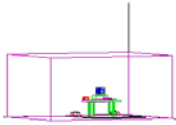

MEASUREMENT REPORT

FCC Part 22, 24, & 27



§2.1033 General Information



APPLICANT: LG Electronics MobileComm U.S.A
APPLICANT ADDRESS: 1000 Sylvan Avenue
 Englewood Cliffs, NJ 07632, United States
TEST SITE: PCTEST ENGINEERING LABORATORY, INC.
TEST SITE ADDRESS: 7185 Oakland Mills Road, Columbia, MD 21045 USA
FCC RULE PART(S): §2; §22; §24; §27
BASE MODEL: LG-V930
FCC ID: ZNFV930
FCC CLASSIFICATION: PCS Licensed Transmitter (PCB)
FREQUENCY TOLERANCE: ±0.00025 % (2.5 ppm)
Test Device Serial No.: 351895070010580 Production Pre-Production Engineering
DATE(S) OF TEST: 7/20-7/26/2015
TEST REPORT S/N: 0Y1507241429.ZNF

Test Facility / Accreditations

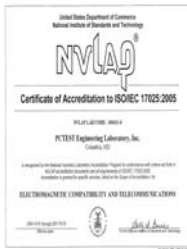
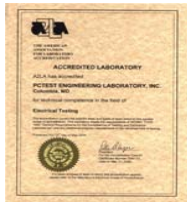
Measurements were performed at PCTEST Engineering Lab located in Columbia, MD 21046, U.S.A.



- PCTEST facility is an FCC registered (PCTEST Reg. No. 159966) test facility with the site description report on file and has met all the requirements specified in Section 2.948 of the FCC Rules and Industry Canada (2451B-1).
- PCTEST Lab is accredited to ISO 17025 by U.S. National Institute of Standards and Technology (NIST) under the National Voluntary Laboratory Accreditation Program (NVLAP Lab code: 100431-0) in EMC, FCC and Telecommunications.
- PCTEST Lab is accredited to ISO 17025-2005 by the American Association for Laboratory Accreditation (A2LA) in Specific Absorption Rate (SAR) testing, Hearing Aid Compatibility (HAC) testing, CTIA Test Plans, and wireless testing for FCC and Industry Canada Rules.
- PCTEST Lab is a recognized U.S. Conformity Assessment Body (CAB) in EMC and R&TTE (n.b. 0982) under the U.S.-EU Mutual Recognition Agreement (MRA).
- PCTEST TCB is a Telecommunication Certification Body (TCB) accredited to ISO/IEC Guide 65 by the American National Standards Institute (ANSI) in all scopes of FCC Rules and Industry Canada Standards (RSS).
- PCTEST facility is an IC registered (2451B-1) test laboratory with the site description on file at Industry Canada.
- PCTEST is a CTIA Authorized Test Laboratory (CATL) for AMPS, CDMA, and EvDO wireless devices and for Over-the-Air (OTA) Antenna Performance testing for AMPS, CDMA, GSM, GPRS, EGPRS, UMTS (W-CDMA), CDMA 1xEVDO, and CDMA 1xRTT.

FCC ID: ZNFV930		FCC Pt. 22, 24, & 27 LTE MEASUREMENT REPORT (CLASS II PERMISSIVE CHANGE)		Reviewed by: Quality Manager
Test Report S/N: 0Y1507241429.ZNF	Test Dates: 7/20-7/26/2015	EUT Type: Portable Tablet	Page 3 of 29	

1.0 INTRODUCTION

1.1 Scope

Measurement and determination of electromagnetic emissions (EME) of radio frequency devices including intentional and/or unintentional radiators for compliance with the technical rules and regulations of the Federal Communications Commission and the Industry Canada Certification and Engineering Bureau.

1.2 Testing Facility

The map below shows the location of the PCTEST LABORATORY, its proximity to the FCC Laboratory, the Columbia vicinity, the Baltimore-Washington Intern't'l (BWI) airport, the city of Baltimore and the Washington, DC area. (See Figure 1-1).

These measurement tests were conducted at the PCTEST Engineering Laboratory, Inc. facility located at 7185 Oakland Mills Road, Columbia, MD 21046. The site coordinates are 39° 10'23" N latitude and 76° 49'50" W longitude. The facility is 0.4 miles North of the FCC laboratory, and the ambient signal and ambient signal strength are approximately equal to those of the FCC laboratory. The detailed description of the measurement facility was found to be in compliance with the requirements of § 2.948 according to ANSI C63.4-2003 on February 15, 2012.

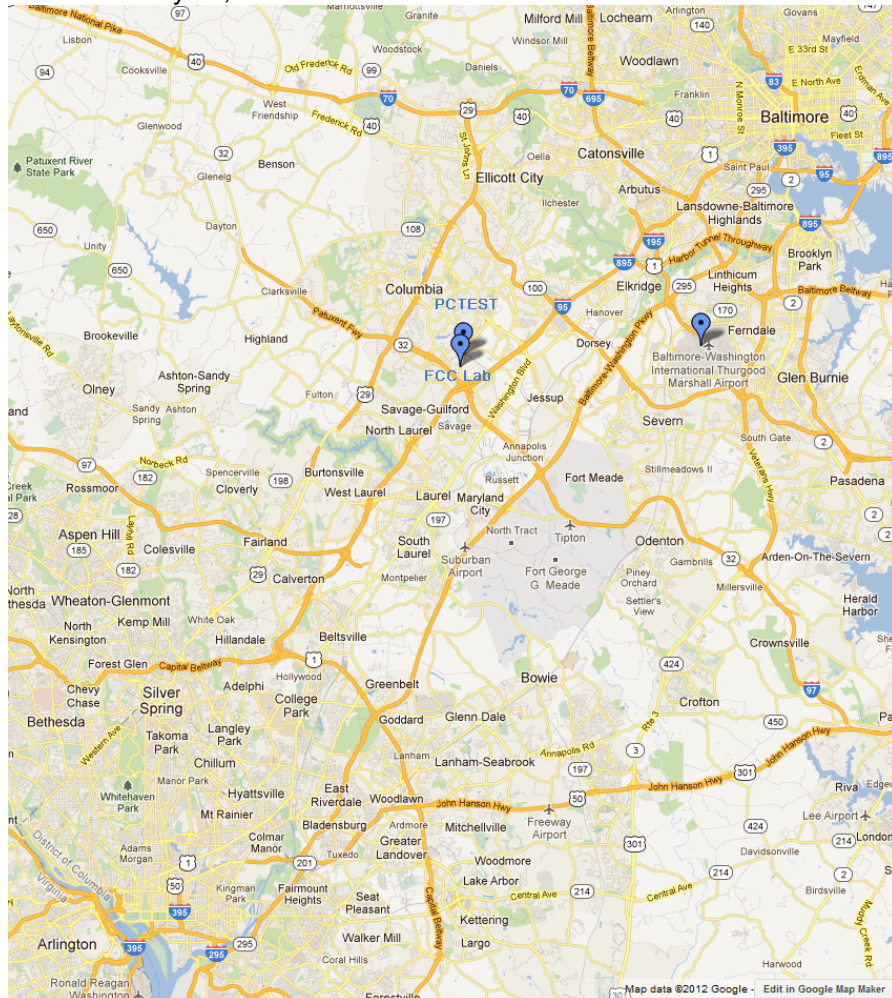

Figure 1-1. Map of the Greater Baltimore and Metropolitan Washington, D.C. area

FCC ID: ZNFV930	PCTEST ENGINEERING LABORATORY, INC.	FCC Pt. 22, 24, & 27 LTE MEASUREMENT REPORT (CLASS II PERMISSIVE CHANGE)		Reviewed by: Quality Manager
Test Report S/N: 0Y1507241429.ZNF	Test Dates: 7/20-7/26/2015	EUT Type: Portable Tablet		Page 4 of 29

2.0 PRODUCT INFORMATION

2.1 Equipment Description

The Equipment Under Test (EUT) is the **LG Portable Tablet FCC ID: ZNFV930**. The test data contained in this report pertains only to the emissions due to the EUT's LTE function.

2.2 Device Capabilities

This device contains the following capabilities:

850/1900 WCDMA/HSPA, Multi-band LTE, 802.11b/g/n WLAN, 802.11a/n/ac UNII, Bluetooth (1x, EDR, LE)



This device supports LTE Bands 12(701.5-713.5MHz) and 17(706.5-713.5MHz), however, only Band 12 measurements are shown in this report since the frequency range of LTE Band 12 encompasses that of Band 17. Furthermore, modulation and antenna paths are identical.

2.3 Test Configuration

The LG Portable Tablet FCC ID: ZNFV930 was tested per the guidance of ANSI/TIA-603-C-2004 and KDB 971168 v02r02. See Section 6.0 of this test report for a description of the radiated and antenna port conducted emissions tests.

2.4 EMI Suppression Device(s)/Modifications

No EMI suppression device(s) were added and no modifications were made during testing.

FCC ID: ZNFV930		FCC Pt. 22, 24, & 27 LTE MEASUREMENT REPORT (CLASS II PERMISSIVE CHANGE)		Reviewed by: Quality Manager
Test Report S/N: 0Y1507241429.ZNF	Test Dates: 7/20-7/26/2015	EUT Type: Portable Tablet		Page 5 of 29

3.0 DESCRIPTION OF TESTS

3.1 Measurement Procedure

The measurement procedures described in the document titled “Land Mobile FM or PM – Communications Equipment – Measurements and Performance Standards” (ANSI/TIA-603-C-2004) and “Procedures for Compliance Measurement of the Fundamental Emission Power of Licensed Wideband (> 1 MHz) Digital Transmission Systems” (KDB 971168) were used in the measurement of the **LG Portable Tablet FCC ID: ZNFV930**.

3.2 Block A Frequency Range

§27.5(c)

698-746 MHz band. The following frequencies are available for licensing pursuant to this part in the 698-746 MHz band: (1) Three paired channel blocks of 12 megahertz each are available for assignment as follows:

Block A: 698-704 MHz and 728-734 MHz;
 Block B: 704-710 MHz and 734-740 MHz; and
 Block C: 710-716 MHz and 740-746 MHz.

3.3 Cellular - Base Frequency Blocks

§22.905

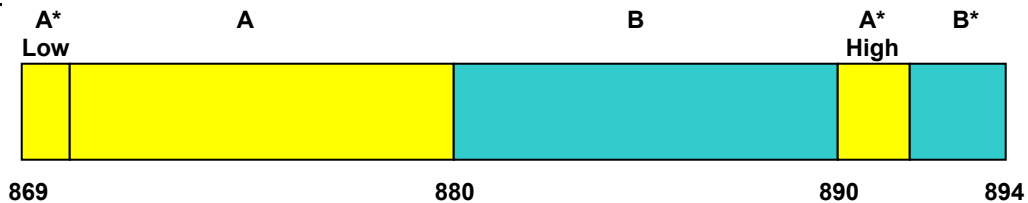

BLOCK 1: 869 – 880 MHz (A* Low + A)
BLOCK 2: 880 – 890 MHz (B)

BLOCK 3: 890 – 891.5 MHz (A* High)
BLOCK 4: 891.5 – 894 MHz (B*)

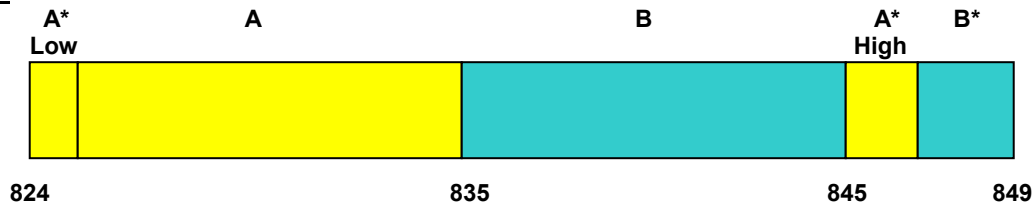

3.4 Cellular - Mobile Frequency Blocks

§22.905



BLOCK 1: 824 – 835 MHz (A* Low + A)
BLOCK 2: 835 – 845 MHz (B)

BLOCK 3: 845 – 846.5 MHz (A* High)
BLOCK 4: 846.5 – 849 MHz (B*)

FCC ID: ZNFV930		FCC Pt. 22, 24, & 27 LTE MEASUREMENT REPORT (CLASS II PERMISSIVE CHANGE)		Reviewed by: Quality Manager
Test Report S/N: 0Y1507241429.ZNF	Test Dates: 7/20-7/26/2015	EUT Type: Portable Tablet	Page 6 of 29	

3.5 PCS - Base Frequency Blocks

§24.229

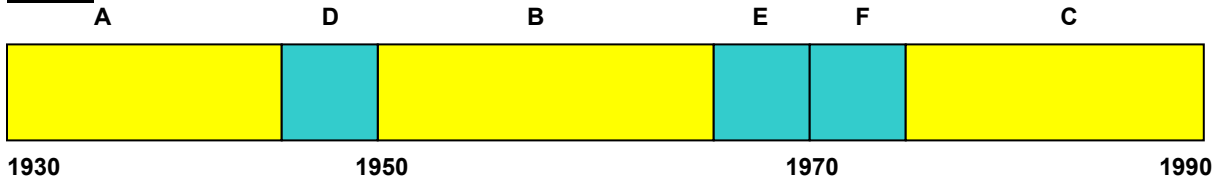

- BLOCK 1: 1930 – 1945 MHz (A)
- BLOCK 2: 1945 – 1950 MHz (D)
- BLOCK 3: 1950 – 1965 MHz (B)
- BLOCK 4: 1965 – 1970 MHz (E)
- BLOCK 5: 1970 – 1975 MHz (F)
- BLOCK 6: 1975 – 1990 MHz (C)

3.6 PCS - Mobile Frequency Blocks

§24.229

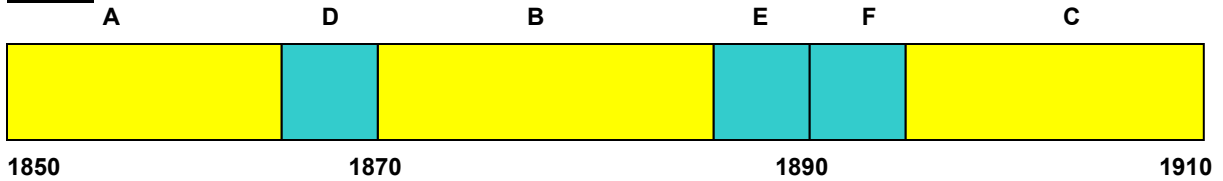

- BLOCK 1: 1850 – 1865 MHz (A)
- BLOCK 2: 1865 – 1870 MHz (D)
- BLOCK 3: 1870 – 1885 MHz (B)
- BLOCK 4: 1885 – 1890 MHz (E)
- BLOCK 5: 1890 – 1895 MHz (F)
- BLOCK 6: 1895 – 1910 MHz (C)

3.7 AWS - Base Frequency Blocks

§27.5(h)

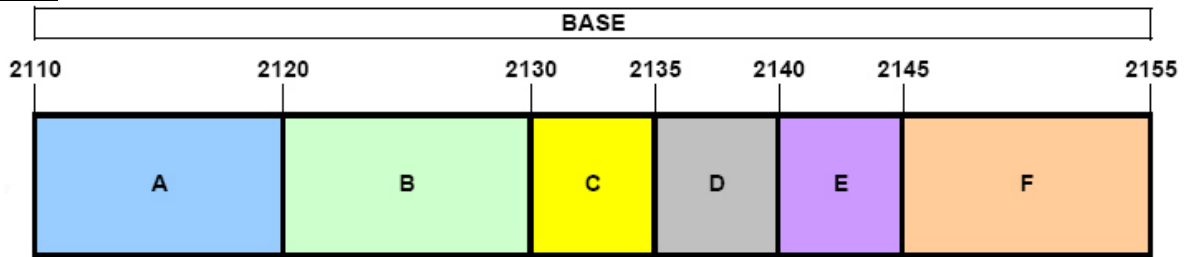

- BLOCK 1: 2110 – 2120 MHz (A)
- BLOCK 2: 2120 – 2130 MHz (B)
- BLOCK 3: 2130 – 2135 MHz (C)
- BLOCK 4: 2135 – 2140 MHz (D)
- BLOCK 5: 2140 – 2145 MHz (E)
- BLOCK 6: 2145 – 2155 MHz (F)

3.8 AWS - Mobile Frequency Blocks

§27.5(h)

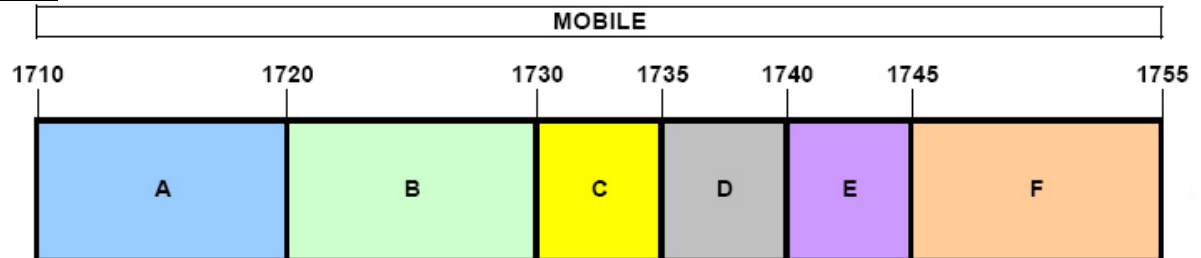

- BLOCK 1: 1710 – 1720 MHz (A)
- BLOCK 2: 1720 – 1730 MHz (B)
- BLOCK 3: 1730 – 1735 MHz (C)
- BLOCK 4: 1735 – 1740 MHz (D)
- BLOCK 5: 1740 – 1745 MHz (E)
- BLOCK 6: 1745 – 1755 MHz (F)

FCC ID: ZNFV930	PCTEST ENGINEERING LABORATORY, INC.	FCC Pt. 22, 24, & 27 LTE MEASUREMENT REPORT (CLASS II PERMISSIVE CHANGE)	LG	Reviewed by: Quality Manager
Test Report S/N: 0Y1507241429.ZNF	Test Dates: 7/20-7/26/2015	EUT Type: Portable Tablet		Page 7 of 29

3.9 BRS/EBS Frequency Block

§27.5

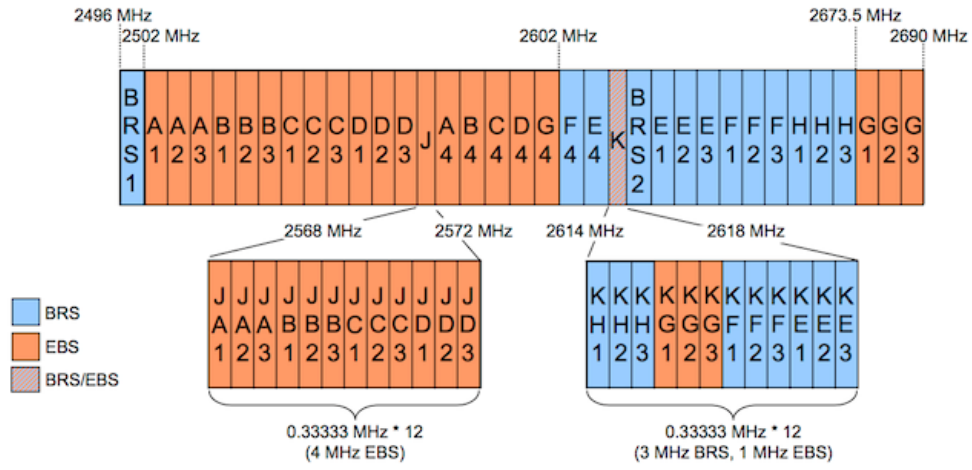

FCC ID: ZNFV930		FCC Pt. 22, 24, & 27 LTE MEASUREMENT REPORT (CLASS II PERMISSIVE CHANGE)		Reviewed by: Quality Manager
Test Report S/N: 0Y1507241429.ZNF	Test Dates: 7/20-7/26/2015	EUT Type: Portable Tablet		Page 8 of 29

3.10 Radiated Power and Radiated Spurious Emissions

§2.1053 §22.913(a.2) §22.917(a) §24.232(c) §24.238(a) §27.50(c.10) §27.50(d.4) §27.53(g) §27.53(h)

The radiated test facilities consisted of an indoor 3 meter semi-anechoic chamber used for final measurements and exploratory measurements, when necessary. The measurement area is contained within the semi-anechoic chamber which is shielded from any ambient interference. The test site inside the chamber is a 6m x 5.2m elliptical, obstruction-free area in accordance with Clause 5, Figure 5.7 of ANSI C63.4-2009. For measurements above 1GHz absorbers are arranged on the floor between the turn table and the antenna mast in such a way so as to maximize the reduction of reflections. For measurements below 1GHz, the absorbers are removed. An ETS Lindgren Model 2188 raised turntable is used for radiated measurement. It is a continuously rotatable, remote-controlled, metallic turntable and 2 meters (6.56 ft.) in diameter. The turn table is flush with the raised floor of the chamber in order to maintain its function as a ground plane. A 78cm high PVC support structure is placed on top of the turntable. A 3/4" (~1.9cm) sheet of high density polyethylene is used as the table top and is placed on top of the PVC supports to bring the total height of the table to 80cm.



The equipment under test was transmitting while connected to its integral antenna and is placed on a wooden turntable 80cm above the ground plane and 3 meters from the receive antenna. The receive antenna height is adjusted between 1 and 4 meter height, the turntable is rotated through 360 degrees, and the EUT is manipulated through all orthogonal planes representative of its typical use to achieve the highest reading on the receive spectrum analyzer. Radiated power levels are also investigated with the receive antenna horizontally and vertically polarized. The maximized power level is recorded using the spectrum analyzer "Channel Power" function with the integration band set to the emissions' occupied bandwidth, a RMS detector, RBW = 100kHz, VBW = 300kHz, and a 1 second sweep time over a minimum of 10 sweeps, per the guidelines of KDB 971168.

Per the guidance of ANSI/TIA-603-C-2004, a half-wave dipole is then substituted in place of the EUT. For emissions above 1GHz, a horn antenna is substituted in place of the EUT. The substitute antenna is driven by a signal generator with the level of the signal generator being adjusted to obtain the same receive spectrum analyzer level previously recorded from the spurious emission from the EUT. The power of the emission is calculated using the following formula:

$$P_d [dBm] = P_g [dBm] - \text{cable loss} [dB] + \text{antenna gain} [dBd/dBi]$$

Where, P_d is the dipole equivalent power, P_g is the generator output into the substitution antenna, and the antenna gain is the gain of the substitute antenna used relative to either a half-wave dipole (dBd) or an isotropic source (dBi). The substitute level is equal to $P_g [dBm] - \text{cable loss} [dB]$.

The calculated P_d levels are then compared to the absolute spurious emission limit of -13dBm which is equivalent to the required minimum attenuation of $43 + 10\log_{10}(\text{Power} [Watts])$. For Band 7, the calculated P_d levels are compared to the absolute spurious emission limit of -25dBm which is equivalent to the required minimum attenuation of $55 + 10\log_{10}(\text{Power} [Watts])$.

FCC ID: ZNFV930		FCC Pt. 22, 24, & 27 LTE MEASUREMENT REPORT (CLASS II PERMISSIVE CHANGE)		Reviewed by: Quality Manager
Test Report S/N: 0Y1507241429.ZNF	Test Dates: 7/20-7/26/2015	EUT Type: Portable Tablet	Page 9 of 29	

4.0 TEST EQUIPMENT CALIBRATION DATA



Test Equipment Calibration is traceable to the National Institute of Standards and Technology (NIST).

Manufacturer	Model	Description	Cal Date	Cal Interval	Cal Due	Serial Number
-	RE1	Radiated Emissions Cable Set (UHF/EHF)	10/24/2014	Annual	10/24/2015	N/A
Anritsu	MT8820C	Radio Communication Analyzer	3/10/2015	Annual	3/10/2016	6200901190
Emco	3115	Horn Antenna (1-18GHz)	1/30/2014	Biennial	1/30/2016	9704-5182
ETS Lindgren	3164-08	Quad Ridge Horn Antenna	10/22/2014	Biennial	10/22/2016	128338
K & L	11SH10	Band Pass Filter	N/A			1300/4000
K & L	11SH10-3075/U18000	High Pass Filter	12/1/2014	Annual	12/1/2015	2
K & L	13SH10-1000/U1000	N Type High Pass Filter	12/1/2014	Annual	12/1/2015	1
Mini Circuits	PWR-SEN-4GHS	USB Power Sensor	3/11/2015	Annual	3/11/2016	11401010036
Mini-Circuits	SSG-4000HP	USB Synthesized Signal Generator	N/A			11208010032
Mini-Circuits	TVA-11-422	RF Power Amp	N/A			QA1303002
Rhode & Schwarz	TS-PR18	Pre-Amplifier	3/5/2015	Annual	3/5/2016	101622
Rohde & Schwarz	ESU26	EMI Test Receiver (26.5GHz)	3/12/2015	Annual	3/12/2016	100342
Rohde & Schwarz	TS-PR18	1-18 GHz Pre-Amplifier	3/5/2015	Annual	3/5/2016	100071
Schwarzbeck	UHA 9105	Dipole Antenna (400 - 1GHz) Rx	11/21/2013	Biennial	11/21/2015	9105-2404
Seekonk	NC-100	Torque Wrench 5/16", 8" lbs	3/18/2014	Biennial	3/18/2016	N/A
VWR	62344-734	Thermometer with Clock	2/20/2014	Biennial	2/20/2016	140140336

Table 4-1. Test Equipment

Note:

Equipment with a calibration date of "N/A" shown in this list was not used to make direct calibrated measurements.



FCC ID: ZNFV930		FCC Pt. 22, 24, & 27 LTE MEASUREMENT REPORT (CLASS II PERMISSIVE CHANGE)		Reviewed by: Quality Manager
Test Report S/N: 0Y1507241429.ZNF	Test Dates: 7/20-7/26/2015	EUT Type: Portable Tablet	Page 10 of 29	

5.0 SAMPLE CALCULATIONS

Spurious Radiated Emission – LTE Band

Example: Middle Channel LTE Mode 2nd Harmonic (1564 MHz)

The average spectrum analyzer reading at 3 meters with the EUT on the turntable was -81.0 dBm. The gain of the substituted antenna is 8.1 dBi. The signal generator connected to the substituted antenna terminals is adjusted to produce a reading of -81.0 dBm on the spectrum analyzer. The loss of the cable between the signal generator and the terminals of the substituted antenna is 2.0 dB at 1564 MHz. So 6.1 dB is added to the signal generator reading of -30.9 dBm yielding -24.80 dBm. The fundamental EIRP was 25.501 dBm so this harmonic was 25.501 dBm $- (-24.80)$.

FCC ID: ZNFV930		FCC Pt. 22, 24, & 27 LTE MEASUREMENT REPORT (CLASS II PERMISSIVE CHANGE)		Reviewed by: Quality Manager
Test Report S/N: 0Y1507241429.ZNF	Test Dates: 7/20-7/26/2015	EUT Type: Portable Tablet	Page 11 of 29	

6.0 TEST RESULTS

6.1 Summary



Company Name: LG Electronics MobileComm U.S.A
 FCC ID: ZNFV930
 FCC Classification: PCS Licensed Transmitter (PCB)
 Mode(s): LTE

FCC Part Section(s)	Test Description	Test Limit	Test Condition	Result	Reference
TRANSMITTER MODE (TX)					
22.913(a.2)	Effective Radiated Power (Band 5)	< 7 Watts max. ERP	RADIATED	PASS	Section 6.2
24.232(c) 27.50(h.2)	Equivalent Isotropic Radiated Power (Band 2 7)	< 2 Watts max. EIRP		PASS	Section 6.2
27.50(d.4)	Equivalent Isotropic Radiated Power (Band 4)	< 1 Watts max. EIRP		PASS	Section 6.2
2.1053 22.917(a) 24.238(a) 27.53(g) 27.53(h)	Undesirable Emissions	> 43 + 10log ₁₀ (P[Watts]) for all out-of-band emissions		PASS	Section 6.3
27.53(m)	Undesirable Emissions	> 43 + 10log ₁₀ (P[Watts]) at channel edges > 55 + 10log ₁₀ (P[Watts]) at 5.5MHz away and beyond channel edges		PASS	Section 6.3

Table 6-1. Summary of Test Results

Notes:

- All modes of operation and data rates were investigated. The test results shown in the following sections represent the worst case emissions.

FCC ID: ZNFV930		FCC Pt. 22, 24, & 27 LTE MEASUREMENT REPORT (CLASS II PERMISSIVE CHANGE)		Reviewed by: Quality Manager
Test Report S/N: 0Y1507241429.ZNF	Test Dates: 7/20-7/26/2015	EUT Type: Portable Tablet	Page 12 of 29	

6.2 Radiated Power (ERP/EIRP)

§22.913(a.2) §24.232(c.2) §27.50(h.2) §27.50(c.10) §27.50(d.4)

Test Overview

Effective Radiated Power (ERP) and Equivalent Isotropic Radiated Power (EIRP) measurements are performed using the substitution method described in ANSI/TIA-603-C-2004 with the EUT transmitting into an integral antenna. Measurements on signals operating below 1GHz are performed using vertically polarized tuned dipole antennas. Measurements on signals operating above 1GHz are performed using vertically polarized broadband horn antennas. All measurements are performed as RMS average measurements while the EUT is operating at its maximum duty cycle, at maximum power, and at the appropriate frequencies.



Test Procedures Used

KDB 971168 v02r02 – Section 5.2.1

ANSI/TIA-603-C-2004 – Section 2.2.17

Test Settings

1. Radiated power measurements are performed using the signal analyzer's "channel power" measurement capability for signals with continuous operation.
2. RBW = 1 – 5% of the expected OBW, not to exceed 1MHz
3. VBW \geq 3 x RBW
4. Span = 1.5 times the OBW
5. No. of sweep points \geq 2 x span / RBW
6. Detector = RMS
7. Trigger is set to "free run" for signals with continuous operation with the sweep times set to "auto".
8. The integration bandwidth was roughly set equal to the measured OBW of the signal for signals with continuous operation.
9. Trace mode = trace averaging (RMS) over 100 sweeps
10. The trace was allowed to stabilize

FCC ID: ZNFV930		FCC Pt. 22, 24, & 27 LTE MEASUREMENT REPORT (CLASS II PERMISSIVE CHANGE)		Reviewed by: Quality Manager
Test Report S/N: 0Y1507241429.ZNF	Test Dates: 7/20-7/26/2015	EUT Type: Portable Tablet	Page 13 of 29	

Test Setup

The EUT and measurement equipment were set up as shown in the diagram below.

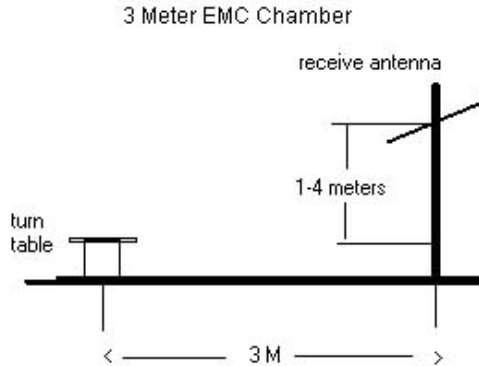



Figure 6-1. Test Instrument & Measurement Setup

Test Notes

- 1) The EUT was tested in three orthogonal planes and in all possible test configurations and positioning. The worst case emissions are reported with the EUT positioning, modulations, RB sizes and offsets, and channel bandwidth configurations shown in the tables below.
- 2) This unit was tested with its standard battery.
- 3) The ERP's and EIRP's listed were measured using the Class II Permissive Change sample, and were found to be within the measurement tolerance of the original certification samples for radiated power. Side by side comparisons have determined that the output power was not changed for these Class II Permissive Change samples.



FCC ID: ZNFV930		FCC Pt. 22, 24, & 27 LTE MEASUREMENT REPORT (CLASS II PERMISSIVE CHANGE)		Reviewed by: Quality Manager
Test Report S/N: 0Y1507241429.ZNF	Test Dates: 7/20-7/26/2015	EUT Type: Portable Tablet	Page 14 of 29	

Frequency [MHz]	Channel Bandwidth [MHz]	Mod.	Battery	RB Size/Offset	Substitute Level [dBm]	Ant. Gain [dBd]	Ant. Pol. [H/V]	ERP [dBm]	ERP Limit [dBm]	Margin [dB]
699.70	1.4	QPSK	Standard	3 / 2	14.24	0.92	V	16.91	34.77	-17.86
707.50	1.4	QPSK	Standard	3 / 2	13.91	1.07	V	16.73	34.77	-18.04
715.30	1.4	QPSK	Standard	3 / 2	14.20	1.23	V	17.18	34.77	-17.60
699.70	1.4	16-QAM	Standard	3 / 2	12.98	0.92	V	15.65	34.77	-19.12
707.50	1.4	16-QAM	Standard	3 / 2	12.66	1.07	V	15.48	34.77	-19.29
715.30	1.4	16-QAM	Standard	3 / 2	12.98	1.23	V	15.96	34.77	-18.82
700.50	3	QPSK	Standard	1 / 14	13.90	0.92	V	16.57	34.77	-18.20
707.50	3	QPSK	Standard	1 / 0	13.75	1.07	V	16.57	34.77	-18.20
714.50	3	QPSK	Standard	1 / 0	14.21	1.21	V	17.17	34.77	-17.60
700.50	3	16-QAM	Standard	1 / 14	12.26	0.92	V	14.93	34.77	-19.84
707.50	3	16-QAM	Standard	1 / 0	11.90	1.07	V	14.72	34.77	-20.05
714.50	3	16-QAM	Standard	1 / 0	12.47	1.21	V	15.43	34.77	-19.34

Table 6-2. ERP Data (Band 12)



Frequency [MHz]	Channel Bandwidth [MHz]	Mod.	Battery	RB Size/Offset	Substitute Level [dBm]	Ant. Gain [dBd]	Ant. Pol. [H/V]	ERP [dBm]	ERP Limit [dBm]	Margin [dB]
701.50	5	QPSK	Standard	1 / 24	14.26	0.94	V	16.95	34.77	-17.82
707.50	5	QPSK	Standard	1 / 24	14.51	1.07	V	17.33	34.77	-17.44
713.50	5	QPSK	Standard	1 / 0	14.71	1.19	V	17.65	34.77	-17.12
701.50	5	16-QAM	Standard	1 / 24	12.53	0.94	V	15.22	34.77	-19.55
707.50	5	16-QAM	Standard	1 / 24	12.80	1.07	V	15.62	34.77	-19.15
713.50	5	16-QAM	Standard	1 / 0	12.92	1.19	V	15.86	34.77	-18.91
704.00	10	QPSK	Standard	1 / 49	14.33	1.00	V	17.08	34.77	-17.69
707.50	10	QPSK	Standard	1 / 49	14.91	1.07	V	17.73	34.77	-17.04
711.00	10	QPSK	Standard	1 / 0	14.23	1.14	V	17.12	34.77	-17.65
704.00	10	16-QAM	Standard	1 / 49	12.63	1.00	V	15.38	34.77	-19.39
707.50	10	16-QAM	Standard	1 / 49	13.19	1.07	V	16.01	34.77	-18.76
711.00	10	16-QAM	Standard	1 / 0	12.53	1.14	V	15.42	34.77	-19.35

Table 6-3. ERP Data (Band 12/17)

FCC ID: ZNFV930		FCC Pt. 22, 24, & 27 LTE MEASUREMENT REPORT (CLASS II PERMISSIVE CHANGE)			Reviewed by: Quality Manager
Test Report S/N: 0Y1507241429.ZNF	Test Dates: 7/20-7/26/2015	EUT Type: Portable Tablet		Page 15 of 29	



Frequency [MHz]	Channel Bandwidth [MHz]	Mod.	Battery	RB Size/Offset	Substitute Level [dBm]	Ant. Gain [dBd]	Ant. Pol. [H/V]	ERP [dBm]	ERP Limit [dBm]	Margin [dB]
824.70	1.4	QPSK	Standard	3 / 2	13.28	2.98	V	18.36	38.45	-20.09
836.50	1.4	QPSK	Standard	3 / 2	14.54	3.04	V	19.68	38.45	-18.77
848.30	1.4	QPSK	Standard	3 / 2	15.44	3.10	V	20.64	38.45	-17.81
824.70	1.4	16-QAM	Standard	3 / 2	12.01	2.98	V	17.09	38.45	-21.36
836.50	1.4	16-QAM	Standard	3 / 2	13.27	3.04	V	18.41	38.45	-20.04
848.30	1.4	16-QAM	Standard	3 / 2	14.21	3.10	V	19.41	38.45	-19.04
825.50	3	QPSK	Standard	1 / 14	12.53	2.98	V	17.61	38.45	-20.84
836.50	3	QPSK	Standard	1 / 14	14.35	3.04	V	19.49	38.45	-18.96
847.50	3	QPSK	Standard	1 / 14	14.94	3.10	V	20.14	38.45	-18.31
825.50	3	16-QAM	Standard	1 / 14	10.88	2.98	V	15.96	38.45	-22.49
836.50	3	16-QAM	Standard	1 / 14	12.74	3.04	V	17.88	38.45	-20.57
847.50	3	16-QAM	Standard	1 / 14	13.42	3.10	V	18.62	38.45	-19.83
826.50	5	QPSK	Standard	1 / 24	13.33	2.99	V	18.42	38.45	-20.03
836.50	5	QPSK	Standard	1 / 24	14.74	3.04	V	19.88	38.45	-18.57
846.50	5	QPSK	Standard	1 / 24	15.27	3.09	V	20.46	38.45	-17.99
826.50	5	16-QAM	Standard	1 / 24	11.69	2.99	V	16.78	38.45	-21.67
836.50	5	16-QAM	Standard	1 / 24	13.05	3.04	V	18.19	38.45	-20.26
846.50	5	16-QAM	Standard	1 / 24	13.63	3.09	V	18.82	38.45	-19.63
829.00	10	QPSK	Standard	1 / 49	14.29	3.00	V	19.39	38.45	-19.06
836.50	10	QPSK	Standard	1 / 49	15.22	3.04	V	20.36	38.45	-18.09
844.00	10	QPSK	Standard	1 / 49	15.59	3.08	V	20.77	38.45	-17.68
829.00	10	16-QAM	Standard	1 / 49	12.73	3.00	V	17.83	38.45	-20.62
836.50	10	16-QAM	Standard	1 / 49	13.65	3.04	V	18.79	38.45	-19.66
844.00	10	16-QAM	Standard	1 / 49	13.92	3.08	V	19.10	38.45	-19.35

Table 6-4. ERP Data (Band 5)

FCC ID: ZNFV930		FCC Pt. 22, 24, & 27 LTE MEASUREMENT REPORT (CLASS II PERMISSIVE CHANGE)		Reviewed by: Quality Manager
Test Report S/N: 0Y1507241429.ZNF	Test Dates: 7/20-7/26/2015	EUT Type: Portable Tablet	Page 16 of 29	



Frequency [MHz]	Channel Bandwidth [MHz]	Mod.	Battery	RB Size/Offset	Substitute Level [dBm]	Ant. Gain [dBi]	Ant. Pol. [H/V]	EIRP [dBm]	EIRP Limit [dBm]	Margin [dB]
1710.70	1.4	QPSK	Standard	3 / 2	12.44	9.28	V	23.92	30.00	-6.08
1732.50	1.4	QPSK	Standard	3 / 2	11.84	9.00	V	23.04	30.00	-6.96
1754.30	1.4	QPSK	Standard	3 / 2	11.32	8.72	V	22.24	30.00	-7.76
1710.70	1.4	16-QAM	Standard	3 / 2	11.20	9.28	V	22.68	30.00	-7.32
1732.50	1.4	16-QAM	Standard	3 / 2	10.54	9.00	V	21.74	30.00	-8.26
1754.30	1.4	16-QAM	Standard	3 / 2	10.10	8.72	V	21.02	30.00	-8.98
1711.50	3	QPSK	Standard	1 / 14	11.06	9.27	V	22.53	30.00	-7.47
1732.50	3	QPSK	Standard	1 / 0	11.67	9.00	V	22.87	30.00	-7.13
1753.50	3	QPSK	Standard	1 / 0	10.79	8.73	V	21.72	30.00	-8.28
1711.50	3	16-QAM	Standard	1 / 14	9.52	9.27	V	20.99	30.00	-9.01
1732.50	3	16-QAM	Standard	1 / 0	9.99	9.00	V	21.19	30.00	-8.81
1753.50	3	16-QAM	Standard	1 / 0	9.00	8.73	V	19.93	30.00	-10.07
1712.50	5	QPSK	Standard	1 / 24	11.76	9.26	V	23.22	30.00	-6.78
1732.50	5	QPSK	Standard	1 / 0	12.03	9.00	V	23.23	30.00	-6.77
1752.50	5	QPSK	Standard	1 / 24	11.25	8.74	V	22.19	30.00	-7.81
1712.50	5	16-QAM	Standard	1 / 24	10.13	9.26	V	21.59	30.00	-8.41
1732.50	5	16-QAM	Standard	1 / 0	10.37	9.00	V	21.57	30.00	-8.43
1752.50	5	16-QAM	Standard	1 / 24	9.52	8.74	V	20.46	30.00	-9.54
1715.00	10	QPSK	Standard	1 / 49	12.00	9.22	V	23.42	30.00	-6.58
1732.50	10	QPSK	Standard	1 / 0	12.32	9.00	V	23.52	30.00	-6.48
1750.00	10	QPSK	Standard	1 / 0	11.26	8.77	V	22.23	30.00	-7.77
1715.00	10	16-QAM	Standard	1 / 49	10.33	9.22	V	21.75	30.00	-8.25
1732.50	10	16-QAM	Standard	1 / 0	10.66	9.00	V	21.86	30.00	-8.14
1750.00	10	16-QAM	Standard	1 / 0	9.58	8.77	V	20.55	30.00	-9.45
1717.50	15	QPSK	Standard	1 / 74	11.83	9.19	V	23.22	30.00	-6.78
1732.50	15	QPSK	Standard	1 / 0	11.90	9.00	V	23.10	30.00	-6.90
1747.50	15	QPSK	Standard	1 / 0	11.57	8.80	V	22.57	30.00	-7.43
1717.50	15	16-QAM	Standard	1 / 74	10.20	9.19	V	21.59	30.00	-8.41
1732.50	15	16-QAM	Standard	1 / 0	10.19	9.00	V	21.39	30.00	-8.61
1747.50	15	16-QAM	Standard	1 / 0	9.88	8.80	V	20.88	30.00	-9.12
1720.00	20	QPSK	Standard	1 / 99	12.29	9.16	V	23.65	30.00	-6.35
1732.50	20	QPSK	Standard	1 / 0	11.84	9.00	V	23.04	30.00	-6.96
1745.00	20	QPSK	Standard	1 / 0	11.85	8.83	V	22.88	30.00	-7.12
1720.00	20	16-QAM	Standard	1 / 99	10.74	9.16	V	22.10	30.00	-7.90
1732.50	20	16-QAM	Standard	1 / 0	10.20	9.00	V	21.40	30.00	-8.60
1745.00	20	16-QAM	Standard	1 / 0	10.34	8.83	V	21.37	30.00	-8.63

Table 6-5. EIRP Data (Band 4)

FCC ID: ZNFV930		FCC Pt. 22, 24, & 27 LTE MEASUREMENT REPORT (CLASS II PERMISSIVE CHANGE)		Reviewed by: Quality Manager
Test Report S/N: 0Y1507241429.ZNF	Test Dates: 7/20-7/26/2015	EUT Type: Portable Tablet	Page 17 of 29	



Frequency [MHz]	Channel Bandwidth [MHz]	Mod.	Battery	RB Size/Offset	Substitute Level [dBm]	Ant. Gain [dBi]	Ant. Pol. [H/V]	EIRP [dBm]	EIRP Limit [dBm]	Margin [dB]
1850.70	1.4	QPSK	Standard	3 / 2	13.06	8.34	V	22.90	33.01	-10.11
1880.00	1.4	QPSK	Standard	3 / 2	12.52	8.46	V	22.48	33.01	-10.53
1909.30	1.4	QPSK	Standard	3 / 2	12.92	8.64	V	23.06	33.01	-9.95
1850.70	1.4	16-QAM	Standard	3 / 2	11.90	8.34	V	21.74	33.01	-11.27
1880.00	1.4	16-QAM	Standard	3 / 2	11.13	8.46	V	21.09	33.01	-11.92
1909.30	1.4	16-QAM	Standard	3 / 2	11.65	8.64	V	21.79	33.01	-11.22
1851.50	3	QPSK	Standard	1 / 0	12.96	8.35	V	22.81	33.01	-10.20
1880.00	3	QPSK	Standard	1 / 0	13.14	8.46	V	23.10	33.01	-9.91
1908.50	3	QPSK	Standard	1 / 0	13.17	8.63	V	23.30	33.01	-9.71
1851.50	3	16-QAM	Standard	1 / 0	11.37	8.35	V	21.22	33.01	-11.79
1880.00	3	16-QAM	Standard	1 / 0	11.57	8.46	V	21.53	33.01	-11.48
1908.50	3	16-QAM	Standard	1 / 0	11.50	8.63	V	21.63	33.01	-11.38
1852.50	5	QPSK	Standard	1 / 0	13.49	8.35	V	23.34	33.01	-9.67
1880.00	5	QPSK	Standard	1 / 0	13.35	8.46	V	23.31	33.01	-9.70
1907.50	5	QPSK	Standard	1 / 0	13.31	8.62	V	23.43	33.01	-9.58
1852.50	5	16-QAM	Standard	1 / 0	11.83	8.35	V	21.68	33.01	-11.33
1880.00	5	16-QAM	Standard	1 / 0	11.63	8.46	V	21.59	33.01	-11.42
1907.50	5	16-QAM	Standard	1 / 0	11.69	8.62	V	21.81	33.01	-11.20
1855.00	10	QPSK	Standard	1 / 49	13.85	8.36	V	23.71	33.01	-9.30
1880.00	10	QPSK	Standard	1 / 49	13.84	8.46	V	23.80	33.01	-9.21
1905.00	10	QPSK	Standard	1 / 49	13.31	8.59	V	23.40	33.01	-9.61
1855.00	10	16-QAM	Standard	1 / 49	12.21	8.36	V	22.07	33.01	-10.94
1880.00	10	16-QAM	Standard	1 / 49	12.29	8.46	V	22.25	33.01	-10.76
1905.00	10	16-QAM	Standard	1 / 49	11.70	8.59	V	21.79	33.01	-11.22
1857.50	15	QPSK	Standard	1 / 0	13.59	8.37	V	23.46	33.01	-9.55
1880.00	15	QPSK	Standard	1 / 0	13.96	8.46	V	23.92	33.01	-9.09
1902.50	15	QPSK	Standard	1 / 0	13.72	8.56	V	23.78	33.01	-9.23
1857.50	15	16-QAM	Standard	1 / 0	12.20	8.37	V	22.07	33.01	-10.94
1880.00	15	16-QAM	Standard	1 / 0	12.31	8.46	V	22.27	33.01	-10.74
1902.50	15	16-QAM	Standard	1 / 0	12.26	8.56	V	22.32	33.01	-10.69
1860.00	20	QPSK	Standard	1 / 99	14.46	8.38	V	24.34	33.01	-8.67
1880.00	20	QPSK	Standard	1 / 99	14.17	8.46	V	24.13	33.01	-8.88
1900.00	20	QPSK	Standard	1 / 0	13.50	8.53	V	23.53	33.01	-9.48
1860.00	20	16-QAM	Standard	1 / 99	12.81	8.38	V	22.69	33.01	-10.32
1880.00	20	16-QAM	Standard	1 / 99	12.74	8.46	V	22.70	33.01	-10.31
1900.00	20	16-QAM	Standard	1 / 0	11.84	8.53	V	21.87	33.01	-11.14

Table 6-6. EIRP Data (Band 2)

FCC ID: ZNFV930		FCC Pt. 22, 24, & 27 LTE MEASUREMENT REPORT (CLASS II PERMISSIVE CHANGE)		Reviewed by: Quality Manager
Test Report S/N: 0Y1507241429.ZNF	Test Dates: 7/20-7/26/2015	EUT Type: Portable Tablet	Page 18 of 29	

Frequency [MHz]	Channel Bandwidth [MHz]	Mod.	Battery	RB Size/Offset	Substitute Level [dBm]	Ant. Gain [dBi]	Ant. Pol. [H/V]	EIRP [dBm]	EIRP Limit [dBm]	Margin [dB]
2502.50	5	QPSK	Standard	1 / 24	11.02	7.09	V	20.31	33.01	-12.70
2535.00	5	QPSK	Standard	1 / 0	10.83	7.26	V	20.29	33.01	-12.72
2567.50	5	QPSK	Standard	1 / 24	10.35	7.42	V	19.97	33.01	-13.04
2502.50	5	16-QAM	Standard	1 / 24	9.31	7.09	V	18.60	33.01	-14.41
2535.00	5	16-QAM	Standard	1 / 0	9.10	7.26	V	18.56	33.01	-14.45
2567.50	5	16-QAM	Standard	1 / 24	8.85	7.42	V	18.47	33.01	-14.54
2505.00	10	QPSK	Standard	1 / 0	11.13	7.10	V	20.43	33.01	-12.58
2535.00	10	QPSK	Standard	1 / 0	11.22	7.26	V	20.68	33.01	-12.33
2565.00	10	QPSK	Standard	1 / 49	10.37	7.41	V	19.98	33.01	-13.03
2505.00	10	16-QAM	Standard	1 / 0	9.49	7.10	V	18.79	33.01	-14.22
2535.00	10	16-QAM	Standard	1 / 0	9.53	7.26	V	18.99	33.01	-14.02
2565.00	10	16-QAM	Standard	1 / 49	8.72	7.41	V	18.33	33.01	-14.68
2507.50	15	QPSK	Standard	1 / 0	11.45	7.12	V	20.77	33.01	-12.24
2535.00	15	QPSK	Standard	1 / 0	10.27	7.26	V	19.73	33.01	-13.28
2562.50	15	QPSK	Standard	1 / 0	10.35	7.39	V	19.94	33.01	-13.07
2507.50	15	16-QAM	Standard	1 / 0	9.72	7.12	V	19.04	33.01	-13.97
2535.00	15	16-QAM	Standard	1 / 0	8.65	7.26	V	18.11	33.01	-14.90
2562.50	15	16-QAM	Standard	1 / 0	8.64	7.39	V	18.23	33.01	-14.78
2510.00	20	QPSK	Standard	1 / 0	12.69	7.13	V	22.02	33.01	-10.99
2535.00	20	QPSK	Standard	1 / 99	12.40	7.26	V	21.86	33.01	-11.15
2560.00	20	QPSK	Standard	1 / 0	11.00	7.38	V	20.58	33.01	-12.43
2510.00	20	16-QAM	Standard	1 / 0	11.17	7.13	V	20.50	33.01	-12.51
2535.00	20	16-QAM	Standard	1 / 99	10.75	7.26	V	20.21	33.01	-12.80
2560.00	20	16-QAM	Standard	1 / 0	9.24	7.38	V	18.82	33.01	-14.19

Table 6-7. EIRP Data (Band 7)

FCC ID: ZNFV930		FCC Pt. 22, 24, & 27 LTE MEASUREMENT REPORT (CLASS II PERMISSIVE CHANGE)		Reviewed by: Quality Manager
Test Report S/N: 0Y1507241429.ZNF	Test Dates: 7/20-7/26/2015	EUT Type: Portable Tablet	Page 19 of 29	

6.3 Radiated Spurious Emissions Measurements

§2.1053 §22.917(a) §24.238(a) §27.53(g) §27.53(h) §27.53(m)

Test Overview

Radiated spurious emissions measurements are performed using the substitution method described in ANSI/TIA-603-C-2004 with the EUT transmitting into an integral antenna. Measurements on signals operating below 1GHz are performed using vertically and horizontally polarized tuned dipole antennas. Measurements on signals operating above 1GHz are performed using vertically and horizontally polarized broadband horn antennas. All measurements are performed as peak measurements while the EUT is operating at its maximum duty cycle, at maximum power, and at the appropriate frequencies.

Test Procedures Used

KDB 971168 v02r02 – Section 5.8

ANSI/TIA-603-C-2004 – Section 2.2.12

Test Settings

1. RBW = 100kHz for emissions below 1GHz and 1MHz for emissions above 1GHz
2. VBW \geq 3 x RBW
3. Span = 1.5 times the OBW
4. No. of sweep points \geq 2 x span / RBW
5. Detector = Peak
6. Trace mode = max hold
7. The trace was allowed to stabilize

Test Setup

The EUT and measurement equipment were set up as shown in the diagram below.

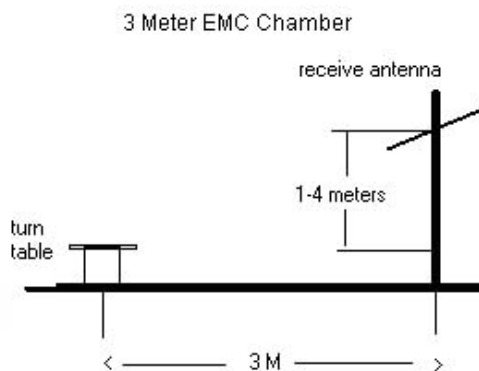



Figure 6-2. Test Instrument & Measurement Setup

FCC ID: ZNFV930		FCC Pt. 22, 24, & 27 LTE MEASUREMENT REPORT (CLASS II PERMISSIVE CHANGE)		Reviewed by: Quality Manager
Test Report S/N: 0Y1507241429.ZNF	Test Dates: 7/20-7/26/2015	EUT Type: Portable Tablet		Page 20 of 29



Test Notes

- 1) The EUT was tested in three orthogonal planes and in all possible test configurations and positioning. The worst case emissions are reported with the EUT positioning, modulations, RB sizes and offsets, and channel bandwidth configurations shown in the tables below.
- 2) This unit was tested with its standard battery.
- 3) The spectrum is measured from 9kHz to the 10th harmonic of the fundamental frequency of the transmitter. The worst-case emissions are reported.
- 4) Emissions below 18GHz were measured at a 3 meter test distance while emissions above 18GHz were measured at a 1 meter test distance with the application of a distance correction factor.
- 5) The ERP's and EIRP's listed were measured using the Class II Permissive Change sample, and were found to be within the measurement tolerances of the original certification samples for radiated power. Side by side comparisons have determined that the output power was not changed for these Class II Permissive Change samples.

OPERATING FREQUENCY: 704.00 MHz
 CHANNEL: 23060
 MEASURED OUTPUT POWER: 17.08 dBm = 0.051 W
 MODULATION SIGNAL: QPSK
 BANDWIDTH: 10.0 MHz
 DISTANCE: 3 meters
 LIMIT: $43 + 10 \log_{10}(W) =$ 30.08 dBc

Frequency [MHz]	Level at Antenna Terminals [dBm]	Substitute Antenna Gain [dBd]	Spurious Emission Level [dBm]	Ant. Pol. [H/V]	[dBc]
1408.00	-66.09	5.70	-60.38	V	77.5
2112.00	-56.40	6.67	-49.73	V	66.8
2816.00	-65.83	7.83	-58.00	V	75.1

Table 6-8. Radiated Spurious Data (Band 12/17 – Low Channel)

FCC ID: ZNFV930		FCC Pt. 22, 24, & 27 LTE MEASUREMENT REPORT (CLASS II PERMISSIVE CHANGE)		Reviewed by: Quality Manager
Test Report S/N: 0Y1507241429.ZNF	Test Dates: 7/20-7/26/2015	EUT Type: Portable Tablet	Page 21 of 29	

OPERATING FREQUENCY: 707.50 MHz
 CHANNEL: 23095
 MEASURED OUTPUT POWER: 17.73 dBm = 0.059 W
 MODULATION SIGNAL: QPSK
 BANDWIDTH: 10.0 MHz
 DISTANCE: 3 meters
 LIMIT: $43 + 10 \log_{10}(W) =$ 30.73 dBc

Frequency [MHz]	Level at Antenna Terminals [dBm]	Substitute Antenna Gain [dBd]	Spurious Emission Level [dBm]	Ant. Pol. [H/V]	[dBc]
1415.00	-66.57	5.75	-60.82	V	78.6
2122.50	-54.52	6.73	-47.79	V	65.5
2830.00	-66.45	7.81	-58.64	V	76.4

Table 6-9. Radiated Spurious Data (Band 12/17 – Mid Channel)

OPERATING FREQUENCY: 711.00 MHz
 CHANNEL: 23130
 MEASURED OUTPUT POWER: 17.12 dBm = 0.052 W
 MODULATION SIGNAL: QPSK
 BANDWIDTH: 10.0 MHz
 DISTANCE: 3 meters
 LIMIT: $43 + 10 \log_{10}(W) =$ 30.12 dBc

Frequency [MHz]	Level at Antenna Terminals [dBm]	Substitute Antenna Gain [dBd]	Spurious Emission Level [dBm]	Ant. Pol. [H/V]	[dBc]
1422.00	-66.03	5.79	-60.24	V	77.4
2133.00	-53.88	6.80	-47.08	V	64.2
2844.00	-66.24	7.79	-58.45	V	75.6

Table 6-10. Radiated Spurious Data (Band 12/17 – High Channel)

OPERATING FREQUENCY: 829.00 MHz
 CHANNEL: 20450
 MEASURED OUTPUT POWER: 19.39 dBm = 0.087 W
 MODULATION SIGNAL: QPSK
 BANDWIDTH: 10.0 MHz
 DISTANCE: 3 meters
 LIMIT: $43 + 10 \log_{10}(W) =$ 32.39 dBc



Frequency [MHz]	Level at Antenna Terminals [dBm]	Substitute Antenna Gain [dBd]	Spurious Emission Level [dBm]	Ant. Pol. [H/V]	[dBc]
1658.00	-39.09	6.59	-32.50	V	51.9
2487.00	-55.97	7.31	-48.67	V	68.1
3316.00	-52.20	7.40	-44.80	V	64.2
4145.00	-58.82	8.14	-50.68	V	70.1

Table 6-11. Radiated Spurious Data (Band 5 – Low Channel)

OPERATING FREQUENCY: 836.50 MHz
 CHANNEL: 20525
 MEASURED OUTPUT POWER: 20.36 dBm = 0.109 W
 MODULATION SIGNAL: QPSK
 BANDWIDTH: 10.0 MHz
 DISTANCE: 3 meters
 LIMIT: $43 + 10 \log_{10}(W) =$ 33.36 dBc

Frequency [MHz]	Level at Antenna Terminals [dBm]	Substitute Antenna Gain [dBd]	Spurious Emission Level [dBm]	Ant. Pol. [H/V]	[dBc]
1673.00	-43.91	6.59	-37.32	V	57.7
2509.50	-56.72	7.34	-49.38	V	69.7
3346.00	-48.91	7.45	-41.46	V	61.8
4182.50	-58.88	8.25	-50.63	V	71.0

Table 6-12. Radiated Spurious Data (Band 5 – Mid Channel)

FCC ID: ZNFV930		FCC Pt. 22, 24, & 27 LTE MEASUREMENT REPORT (CLASS II PERMISSIVE CHANGE)		Reviewed by: Quality Manager
Test Report S/N: 0Y1507241429.ZNF	Test Dates: 7/20-7/26/2015	EUT Type: Portable Tablet	Page 23 of 29	

OPERATING FREQUENCY: 844.00 MHz
 CHANNEL: 20600
 MEASURED OUTPUT POWER: 20.77 dBm = 0.119 W
 MODULATION SIGNAL: QPSK
 BANDWIDTH: 10.0 MHz
 DISTANCE: 3 meters
 LIMIT: $43 + 10 \log_{10}(W) =$ 33.77 dBc



Frequency [MHz]	Level at Antenna Terminals [dBm]	Substitute Antenna Gain [dBd]	Spurious Emission Level [dBm]	Ant. Pol. [H/V]	[dBc]
1688.00	-44.65	6.58	-38.06	V	58.8
2532.00	-57.06	7.36	-49.71	V	70.5
3376.00	-49.32	7.50	-41.82	V	62.6
4220.00	-58.15	8.36	-49.79	V	70.6

Table 6-13. Radiated Spurious Data (Band 5 – High Channel)

OPERATING FREQUENCY: 1710.70 MHz
 CHANNEL: 19957
 MEASURED OUTPUT POWER: 23.92 dBm = 0.247 W
 MODULATION SIGNAL: QPSK
 BANDWIDTH: 1.4 MHz
 DISTANCE: 3 meters
 LIMIT: $43 + 10 \log_{10}(W) =$ 36.92 dBc

Frequency [MHz]	Level at Antenna Terminals [dBm]	Substitute Antenna Gain [dBi]	Spurious Emission Level [dBm]	Ant. Pol. [H/V]	[dBc]
3421.40	-60.10	9.68	-50.42	H	74.3
5132.10	-54.42	10.69	-43.74	H	67.7
6842.80	-56.62	11.74	-44.88	H	68.8
8553.50	-52.85	11.05	-41.79	H	65.7

Table 6-14. Radiated Spurious Data (Band 4 – Low Channel)

FCC ID: ZNFV930		FCC Pt. 22, 24, & 27 LTE MEASUREMENT REPORT (CLASS II PERMISSIVE CHANGE)		Reviewed by: Quality Manager
Test Report S/N: 0Y1507241429.ZNF	Test Dates: 7/20-7/26/2015	EUT Type: Portable Tablet	Page 24 of 29	

OPERATING FREQUENCY: 1732.50 MHz
 CHANNEL: 20175
 MEASURED OUTPUT POWER: 23.04 dBm = 0.201 W
 MODULATION SIGNAL: QPSK
 BANDWIDTH: 1.4 MHz
 DISTANCE: 3 meters
 LIMIT: $43 + 10 \log_{10}(W) =$ 36.04 dBc



Frequency [MHz]	Level at Antenna Terminals [dBm]	Substitute Antenna Gain [dBi]	Spurious Emission Level [dBm]	Ant. Pol. [H/V]	[dBc]
3465.00	-58.71	9.71	-49.01	H	72.0
5197.50	-54.07	10.59	-43.48	H	66.5
6930.00	-57.57	11.75	-45.82	H	68.9
8662.50	-53.66	11.06	-42.59	H	65.6

Table 6-15. Radiated Spurious Data (Band 4 – Mid Channel)

OPERATING FREQUENCY: 1754.30 MHz
 CHANNEL: 20393
 MEASURED OUTPUT POWER: 22.24 dBm = 0.167 W
 MODULATION SIGNAL: QPSK
 BANDWIDTH: 1.4 MHz
 DISTANCE: 3 meters
 LIMIT: $43 + 10 \log_{10}(W) =$ 35.24 dBc

Frequency [MHz]	Level at Antenna Terminals [dBm]	Substitute Antenna Gain [dBi]	Spurious Emission Level [dBm]	Ant. Pol. [H/V]	[dBc]
3508.60	-55.59	9.73	-45.86	H	68.1
5262.90	-53.67	10.65	-43.03	H	65.3
7017.20	-54.78	11.75	-43.02	H	65.3
8771.50	-51.79	10.99	-40.80	H	63.0

Table 6-16. Radiated Spurious Data (Band 4 – High Channel)

FCC ID: ZNFV930		FCC Pt. 22, 24, & 27 LTE MEASUREMENT REPORT (CLASS II PERMISSIVE CHANGE)		Reviewed by: Quality Manager
Test Report S/N: 0Y1507241429.ZNF	Test Dates: 7/20-7/26/2015	EUT Type: Portable Tablet	Page 25 of 29	

OPERATING FREQUENCY: 1860.00 MHz
 CHANNEL: 18700
 MEASURED OUTPUT POWER: 24.34 dBm = 0.272 W
 MODULATION SIGNAL: QPSK
 BANDWIDTH: 20.0 MHz
 DISTANCE: 3 meters
 LIMIT: $43 + 10 \log_{10}(W) =$ 37.34 dBc



Frequency [MHz]	Level at Antenna Terminals [dBm]	Substitute Antenna Gain [dBi]	Spurious Emission Level [dBm]	Ant. Pol. [H/V]	[dBc]
3720.00	-56.83	9.39	-47.44	H	71.8
5580.00	-59.65	10.85	-48.80	H	73.1
7440.00	-55.03	10.79	-44.24	H	68.6

Table 6-17. Radiated Spurious Data (Band 2 – Low Channel)

OPERATING FREQUENCY: 1880.00 MHz
 CHANNEL: 18900
 MEASURED OUTPUT POWER: 24.13 dBm = 0.259 W
 MODULATION SIGNAL: QPSK
 BANDWIDTH: 20.0 MHz
 DISTANCE: 3 meters
 LIMIT: $43 + 10 \log_{10}(W) =$ 37.13 dBc

Frequency [MHz]	Level at Antenna Terminals [dBm]	Substitute Antenna Gain [dBi]	Spurious Emission Level [dBm]	Ant. Pol. [H/V]	[dBc]
3760.00	-55.90	9.28	-46.62	H	70.7
5640.00	-53.26	11.03	-42.22	H	66.4
7520.00	-55.92	10.97	-44.95	H	69.1

Table 6-18. Radiated Spurious Data (Band 2 – Mid Channel)

FCC ID: ZNFV930		FCC Pt. 22, 24, & 27 LTE MEASUREMENT REPORT (CLASS II PERMISSIVE CHANGE)		Reviewed by: Quality Manager
Test Report S/N: 0Y1507241429.ZNF	Test Dates: 7/20-7/26/2015	EUT Type: Portable Tablet	Page 26 of 29	

OPERATING FREQUENCY: 1900.00 MHz
 CHANNEL: 19100
 MEASURED OUTPUT POWER: 23.53 dBm = 0.226 W
 MODULATION SIGNAL: QPSK
 BANDWIDTH: 20.0 MHz
 DISTANCE: 3 meters
 LIMIT: $43 + 10 \log_{10}(W) =$ 36.53 dBc

Frequency [MHz]	Level at Antenna Terminals [dBm]	Substitute Antenna Gain [dBi]	Spurious Emission Level [dBm]	Ant. Pol. [H/V]	[dBc]
3800.00	-55.75	9.18	-46.57	H	70.1
5700.00	-54.42	11.24	-43.18	H	66.7
7600.00	-57.21	11.14	-46.07	H	69.6
9500.00	-53.99	11.69	-42.30	H	65.8
11400.00	-51.93	12.75	-39.18	H	62.7
13300.00	-57.43	12.56	-44.87	H	68.4

Table 6-19. Radiated Spurious Data (Band 2 – High Channel)

OPERATING FREQUENCY: 2510.00 MHz
 CHANNEL: 20850
 MEASURED OUTPUT POWER: 22.02 dBm = 0.159 W
 MODULATION SIGNAL: QPSK
 BANDWIDTH: 20.0 MHz
 DISTANCE: 3 meters
 LIMIT: $55 + 10 \log_{10}(W) =$ 47.02 dBc

Frequency [MHz]	Level at Antenna Terminals [dBm]	Substitute Antenna Gain [dBi]	Spurious Emission Level [dBm]	Ant. Pol. [H/V]	[dBc]
5020.00	-42.01	10.91	-31.11	V	53.1
7530.00	-53.34	10.99	-42.35	V	64.4
10040.00	-54.09	12.06	-42.03	V	64.0

Table 6-20. Radiated Spurious Data (Band 7 – Low Channel)

OPERATING FREQUENCY: 2535.00 MHz
 CHANNEL: 21100
 MEASURED OUTPUT POWER: 21.86 dBm = 0.153 W
 MODULATION SIGNAL: QPSK
 BANDWIDTH: 20.0 MHz
 DISTANCE: 3 meters
 LIMIT: $55 + 10 \log_{10}(W) =$ 46.86 dBc



Frequency [MHz]	Level at Antenna Terminals [dBm]	Substitute Antenna Gain [dBi]	Spurious Emission Level [dBm]	Ant. Pol. [H/V]	[dBc]
5070.00	-48.00	10.80	-37.20	V	59.1
7605.00	-52.51	11.13	-41.39	V	63.2
10140.00	-51.36	12.14	-39.22	V	61.1
12675.00	-53.64	13.72	-39.92	V	61.8

Table 6-21. Radiated Spurious Data (Band 7 – Mid Channel)

OPERATING FREQUENCY: 2560.00 MHz
 CHANNEL: 21350
 MEASURED OUTPUT POWER: 20.58 dBm = 0.114 W
 MODULATION SIGNAL: QPSK
 BANDWIDTH: 20.0 MHz
 DISTANCE: 3 meters
 LIMIT: $55 + 10 \log_{10}(W) =$ 45.58 dBc



Frequency [MHz]	Level at Antenna Terminals [dBm]	Substitute Antenna Gain [dBi]	Spurious Emission Level [dBm]	Ant. Pol. [H/V]	[dBc]
5120.00	-44.91	10.71	-34.21	V	54.8
7680.00	-50.85	11.21	-39.64	V	60.2
10240.00	-50.57	12.24	-38.33	V	58.9
12800.00	-53.72	13.58	-40.14	V	60.7

Table 6-22. Radiated Spurious Data (Band 7 – High Channel)

FCC ID: ZNFV930		FCC Pt. 22, 24, & 27 LTE MEASUREMENT REPORT (CLASS II PERMISSIVE CHANGE)		Reviewed by: Quality Manager
Test Report S/N: 0Y1507241429.ZNF	Test Dates: 7/20-7/26/2015	EUT Type: Portable Tablet	Page 28 of 29	

7.0 CONCLUSION

The data collected relate only to the item(s) tested and show that the **LG Portable Tablet FCC ID: ZNFV930** complies with all the requirements of Parts 22, 24, & 27 of the FCC rules for LTE operation only.

FCC ID: ZNFV930		FCC Pt. 22, 24, & 27 LTE MEASUREMENT REPORT (CLASS II PERMISSIVE CHANGE)		Reviewed by: Quality Manager
Test Report S/N: 0Y1507241429.ZNF	Test Dates: 7/20-7/26/2015	EUT Type: Portable Tablet	Page 29 of 29	