



SAR EVALUATION REPORT

Applicant Name:
 LG Electronics MobileComm U.S.A., Inc.
 1000 Sylvan Avenue
 Englewood Cliffs, NJ 07632
 United States

Date of Testing:
 06/17/15 - 06/23/15
Test Site/Location:
 PCTEST Lab, Columbia, MD, USA
Document Serial No.:
 0Y1506161253-R2.ZNF

FCC ID: ZNFV930

APPLICANT: LG ELECTRONICS MOBILECOMM U.S.A., INC.

DUT Type: Portable Tablet
Application Type: Certification
FCC Rule Part(s): CFR §2.1093
Model(s): LG-V930, LGV930, V930

Equipment Class	Band & Mode	Tx Frequency	SAR
			1 gm Body (W/kg)
PCB	UMTS 850	826.40 - 846.60 MHz	0.55
PCB	UMTS 1900	1852.4 - 1907.6 MHz	0.60
PCB	LTE Band 12	699.7 - 715.3 MHz	0.65
PCB	LTE Band 17	706.5 - 713.5 MHz	0.75
PCB	LTE Band 5 (Cell)	824.7 - 848.3 MHz	0.61
PCB	LTE Band 4 (AWS)	1710.7 - 1754.3 MHz	0.73
PCB	LTE Band 2 (PCS)	1850.7 - 1909.3 MHz	0.73
PCB	LTE Band 7	2502.5 - 2567.5 MHz	0.39
DTS	2.4 GHz WLAN	2412 - 2462 MHz	0.69
Nil	U-NII-1	5180 - 5240 MHz	0.37
Nil	U-NII-2A	5260 - 5320 MHz	< 0.1
Nil	U-NII-2C	5500 - 5700 MHz	N/A
Nil	U-NII-3	5745 - 5825 MHz	1.44
DSS/DTS	Bluetooth	2402 - 2480 MHz	
Simultaneous SAR per KDB 690783 D01v01r03:			

This wireless portable device has been shown to be capable of compliance for localized specific absorption rate (SAR) for uncontrolled environment/general population exposure limits specified in ANSI/IEEE C95.1-1992 and has been tested in accordance with the measurement procedures specified in Section 1.7 of this report; for North American frequency bands only.

Note: This revised Test Report (S/N: 0Y1506161253-R2.ZNF) supersedes and replaces the previously issued test report on the same subject device for the same type of testing as indicated. Please discard or destroy the previously issued test report(s) and dispose of it accordingly.

I attest to the accuracy of data. All measurements reported herein were performed by me or were made under my supervision and are correct to the best of my knowledge and belief. I assume full responsibility for the completeness of these measurements and vouch for the qualifications of all persons taking them. Test results reported herein relate only to the item(s) tested.

Randy Ortanez
 President



The SAR Tick is an initiative of the Mobile Manufacturers Forum (MMF). While a product may be considered eligible, use of the SAR Tick logo requires an agreement with the MMF. Further details can be obtained by emailing: sartick@mmfai.info.

FCC ID: ZNFV930	PCTEST ENGINEERING LABORATORY, INC.	SAR EVALUATION REPORT		Reviewed by: Quality Manager
Document S/N: 0Y1506161253-R2.ZNF	Test Dates: 06/17/15 - 06/23/15	DUT Type: Portable Tablet		Page 1 of 88

T A B L E O F C O N T E N T S

1	DEVICE UNDER TEST	3
2	LTE INFORMATION	8
3	INTRODUCTION	9
4	DOSIMETRIC ASSESSMENT	10
5	SAR TESTING PROCEDURES	11
6	RF EXPOSURE LIMITS	12
7	FCC MEASUREMENT PROCEDURES.....	13
8	RF CONDUCTED POWERS.....	18
9	SYSTEM VERIFICATION.....	70
10	SAR DATA SUMMARY	72
11	FCC MULTI-TX AND ANTENNA SAR CONSIDERATIONS.....	76
12	SAR MEASUREMENT VARIABILITY	82
13	EQUIPMENT LIST.....	83
14	MEASUREMENT UNCERTAINTIES	84
15	CONCLUSION.....	86
16	REFERENCES	87
APPENDIX A: SAR TEST PLOTS		
APPENDIX B: SAR DIPOLE VERIFICATION PLOTS		
APPENDIX C: PROBE AND DIPOLE CALIBRATION CERTIFICATES		
APPENDIX D: SAR TISSUE SPECIFICATIONS		
APPENDIX E: SAR SYSTEM VALIDATION		
APPENDIX F: DUT ANTENNA DIAGRAM & SAR TEST SETUP PHOTOGRAPHS		
APPENDIX G: SENSOR TRIGGERING DATA SUMMARY		

FCC ID: ZNFV930	PCTEST <small>ENGINEERING LABORATORY, INC.</small>	SAR EVALUATION REPORT		Reviewed by: Quality Manager
Document S/N: OY1506161253-R2.ZNF	Test Dates: 06/17/15 - 06/23/15	DUT Type: Portable Tablet	Page 2 of 88	

1 DEVICE UNDER TEST

1.1 Device Overview

Band & Mode	Operating Modes	Tx Frequency
UMTS 850	Data	826.40 - 846.60 MHz
UMTS 1900	Data	1852.4 - 1907.6 MHz
LTE Band 12	Data	699.7 - 715.3 MHz
LTE Band 17	Data	706.5 - 713.5 MHz
LTE Band 5 (Cell)	Data	824.7 - 848.3 MHz
LTE Band 4 (AWS)	Data	1710.7 - 1754.3 MHz
LTE Band 2 (PCS)	Data	1850.7 - 1909.3 MHz
LTE Band 7	Data	2502.5 - 2567.5 MHz
2.4 GHz WLAN	Data	2412 - 2462 MHz
U-NII-1	Data	5180 - 5240 MHz
U-NII-2A	Data	5260 - 5320 MHz
U-NII-2C	Data	5500 - 5700 MHz
U-NII-3	Data	5745 - 5825 MHz
Bluetooth	Data	2402 - 2480 MHz

1.2 Power Reduction for SAR



This device uses a sensor for SAR compliance. The sensor is activated when used in close proximity to the user's body. The sensor triggers power reduction for data modes and is only applicable for tablet operations. Since the device is a full sized tablet, the Body SAR was evaluated per FCC KDB Publication 616217 D04 for full sized tablets.

1.3 Nominal and Maximum Output Power Specifications

This device operates using the following maximum and nominal output power specifications. SAR values were scaled to the maximum allowed power to determine compliance per KDB Publication 447498 D01v05.

Maximum Power

Mode / Band		Modulated Average (dBm)		
		3GPP WCDMA Rel 99	3GPP HSDPA Rel 5	3GPP HSUPA Rel 6
UMTS Band 5 (850 MHz)	Maximum	24.0	24.0	24.0
	Nominal	23.5	23.5	23.5
UMTS Band 2 (1900 MHz)	Maximum	24.0	24.0	24.0
	Nominal	23.5	23.5	23.5



FCC ID: ZNFV930	 PCTEST ENGINEERING LABORATORY, INC.	SAR EVALUATION REPORT		Reviewed by: Quality Manager
Document S/N: OY1506161253-R2.ZNF	Test Dates: 06/17/15 - 06/23/15	DUT Type: Portable Tablet		Page 3 of 88

Mode / Band		Modulated Average (dBm)
LTE Band 12	Maximum	24.5
	Nominal	24.0
LTE Band 17	Maximum	24.5
	Nominal	24.0
LTE Band 5 (Cell)	Maximum	24.5
	Nominal	24.0
LTE Band 4 (AWS)	Maximum	25.0
	Nominal	24.5
LTE Band 2 (PCS)	Maximum	25.0
	Nominal	24.5
LTE Band 7	Maximum	23.0
	Nominal	22.5

Reduced Power – Body at 0.0 cm

Mode / Band		Modulated Average (dBm)		
		3GPP WCDMA Rel 99	3GPP HSDPA Rel 5	3GPP HSUPA Rel 6
UMTS Band 5 (850 MHz)	Maximum	18.5	18.5	18.5
	Nominal	18.0	18.0	18.0
UMTS Band 2 (1900 MHz)	Maximum	12.5	12.5	12.5
	Nominal	12.0	12.0	12.0

Mode / Band		Modulated Average (dBm)
LTE Band 12	Maximum	18.5
	Nominal	18.0
LTE Band 17	Maximum	18.5
	Nominal	18.0
LTE Band 5 (Cell)	Maximum	18.5
	Nominal	18.0
LTE Band 4 (AWS)	Maximum	12.5
	Nominal	12.0
LTE Band 2 (PCS)	Maximum	12.5
	Nominal	12.0
LTE Band 7	Maximum	12.5
	Nominal	12.0

FCC ID: ZNFV930		SAR EVALUATION REPORT		Reviewed by: Quality Manager
Document S/N: OY1506161253-R2.ZNF	Test Dates: 06/17/15 - 06/23/15	DUT Type: Portable Tablet		Page 4 of 88

WLAN/BT Antenna Maximum Power

Mode / Band		Modulated Average (dBm)
IEEE 802.11b (2.4 GHz)	Maximum	11.0
	Nominal	10.0
IEEE 802.11g (2.4 GHz)	Maximum	9.0
	Nominal	8.0
IEEE 802.11n (2.4 GHz)	Maximum	9.0
	Nominal	8.0
Bluetooth	Maximum	9.5
	Nominal	8.5
Bluetooth LE	Maximum	1.0
	Nominal	0.0

Mode / Band		Modulated Average (dBm)		
		20 MHz Bandwidth	40 MHz Bandwidth	80 MHz Bandwidth
IEEE 802.11a (5 GHz)	Maximum	8.0		
	Nominal	7.0		
IEEE 802.11n (5 GHz)	Maximum	8.0	6.5	
	Nominal	7.0	5.5	
IEEE 802.11ac (5 GHz)	Maximum	8.0	6.5	6.5
	Nominal	7.0	5.5	5.5



1.4 DUT Antenna Locations

The overall diagonal dimension of the device is > 200 mm. A diagram showing the locations of the device antennas can be found in Appendix F. Exact antenna dimensions and separation distances are shown in the Technical Descriptions in the FCC filing.

**Table 1-1
Sides for SAR Testing**

Mode	Back	Top	Bottom	Right	Left
UMTS 850	Yes	Yes	No	No	Yes
UMTS 1900	Yes	No	No	Yes	No
LTE Band 12	Yes	Yes	No	No	Yes
LTE Band 5 (Cell)	Yes	Yes	No	No	Yes
LTE Band 4 (AWS)	Yes	No	No	Yes	No
LTE Band 2 (PCS)	Yes	No	No	Yes	No
LTE Band 7	Yes	Yes	No	No	Yes
2.4 GHz WLAN	Yes	Yes	No	Yes	No
5 GHz WLAN	Yes	Yes	No	Yes	No

Note: Per FCC KDB 616217 D04v01r01, particular DUT edges were not required to be evaluated for SAR based on the SAR exclusion threshold in KDB 447498 D01v05r01.

FCC ID: ZNFV930	 SAR EVALUATION REPORT 		Reviewed by: Quality Manager
Document S/N: OY1506161253-R2.ZNF	Test Dates: 06/17/15 - 06/23/15	DUT Type: Portable Tablet	Page 5 of 88

1.5 Simultaneous Transmission Capabilities

According to FCC KDB Publication 447498 D05v01, transmitters are considered to be transmitting simultaneously when there is overlapping transmission, with the exception of transmissions during network hand-offs with maximum hand-off duration less than 30 seconds. Possible transmission paths for the DUT are shown in Figure 1-1 and are color-coded to indicate communication modes which share the same path. Modes which share the same transmission path cannot transmit simultaneously with one another.



Figure 1-1
Simultaneous Transmission Paths

This device contains multiple transmitters that may operate simultaneously, and therefore requires a simultaneous transmission analysis according to FCC KDB Publication 447498 D01v05 3) procedures.

Table 1-2
Simultaneous Transmission Scenarios

No.	Capable Transmit Configuration	Body
1	UMTS + 2.4 GHz WI-FI	Yes
2	UMTS + 5 GHz WI-FI	Yes
3	UMTS + 2.4 GHz Bluetooth	Yes
4	LTE + 2.4 GHz WI-FI	Yes
5	LTE + 5 GHz WI-FI	Yes
6	LTE + 2.4 GHz Bluetooth	Yes

- 2.4 GHz WLAN, 5 GHz WLAN, and 2.4 GHz Bluetooth share the same antenna path and cannot transmit simultaneously.
- All licensed modes share the same antenna path and cannot transmit simultaneously.

1.6 Miscellaneous SAR Test Considerations



(A) WIFI/BT

Per FCC KDB 447498 D01v05, the 1g SAR exclusion threshold for distances <50mm is defined by the following equation:

$$\frac{\text{Max Power of Channel (mW)}}{\text{Test Separation Dist (mm)}} * \sqrt{\text{Frequency(GHz)}} \leq 3.0$$

Based on the maximum conducted power of Bluetooth (rounded to the nearest mW) and the antenna to user separation distance, body Bluetooth SAR was not required; $[(9/5) * \sqrt{2.480}] = 2.8 < 3.0$. Per KDB Publication 447498 D01v05, the maximum power of the channel was rounded to the nearest mW before calculation.

Since U-NII-1 and U-NII-2A bands have the same maximum output power and the highest reported SAR for U-NII-2A is less than 1.2 W/kg, SAR is not required for U-NII-1 band according to FCC KDB 248227 D01v02r01.

FCC ID: ZNFV930	 SAR EVALUATION REPORT 		Reviewed by: Quality Manager
Document S/N: OY1506161253-R2.ZNF	Test Dates: 06/17/15 - 06/23/15	DUT Type: Portable Tablet	Page 6 of 88

This device supports IEEE 802.11ac with the following features:

- a) Up to 80 MHz Bandwidth only
- b) No aggregate channel configurations
- c) 1 Tx antenna output
- d) 256 QAM is supported
- e) Band gap channels are not supported

(B) Licensed Transmitter(s)

This device is only capable of QPSK HSUPA in the uplink. Therefore, no additional SAR tests are required beyond that described for devices with HSUPA in KDB 941225 D01v03.

LTE SAR for the higher modulations and lower bandwidths were not tested since the maximum average output power of all required channels and configurations was not more than 0.5 dB higher than the highest bandwidth; and the reported LTE SAR for the highest bandwidth was less than 1.45 W/kg for all configurations according to FCC KDB 941225 D05v02r03.

This device additionally supports LTE Band 17. LTE Band 12 and LTE Band 17 share the same transmission path. LTE Band 17 was not evaluated for SAR since the supported frequency range falls within the LTE Band 12 supported frequency range and the Band 17 target power was equal to the Band 12 target power.

This device supports inter-band LTE Carrier Aggregation (CA) in the downlink only. All uplink communications are identical to Release 8 specifications. Per FCC KDB Publication 941225 D05A v01r01, SAR for LTE CA operations was not needed since the maximum average output power in LTE CA mode was not >0.25 dB higher than the maximum output power when downlink carrier aggregation was inactive.



1.7 Guidance Applied

- FCC KDB Publication 941225 D01v03, D05v02r03 (3G/4G)
- FCC KDB Publication 248227 D01v02r01 (SAR Considerations for 802.11 Devices)
- FCC KDB Publication 447498 D01v05r02 (General SAR Guidance)
- FCC KDB Publication 865664 D01v01r03, D02v01r01 (SAR Measurements up to 6 GHz)
- FCC KDB Publication 616217 D04v01r01 (Tablet SAR Considerations)

1.8 Device Serial Numbers

Several samples with identical hardware were used to support SAR testing. The manufacturer has confirmed that the device(s) tested have the same physical, mechanical and thermal characteristics and are within operational tolerances expected for production units.

	Maximum Serial Number	Reduced Serial Number
UMTS 850	02231	02256
UMTS 1900	02231	02256
LTE Band 12	02231	02249
LTE Band 5 (Cell)	02231	02256
LTE Band 4 (AWS)	02223	02256
LTE Band 2 (PCS)	02231	02256
LTE Band 7	02223	02249
2.4 GHz WLAN	02264	N/A
5 GHz WLAN	02264	N/A

FCC ID: ZNFV930	 SAR EVALUATION REPORT 		Reviewed by: Quality Manager
Document S/N: OY1506161253-R2.ZNF	Test Dates: 06/17/15 - 06/23/15	DUT Type: Portable Tablet	Page 7 of 88

© 2015 PCTEST Engineering Laboratory, Inc.



REV 16.0 M
06/12/2015

(c) 2015 PCTEST Engineering Laboratory, Inc. All rights reserved. Unless otherwise specified, no part of this report may be reproduced or utilized in any part, form or by any means, electronic or mechanical, including photocopying and microfilm, without permission in writing from PCTEST Engineering Laboratory, Inc. If you have any questions about this international copyright or have an enquiry about obtaining additional rights to this report or assembly of contents thereof, please contact info@pctestlab.com.

2

LTE INFORMATION

LTE Information			
FCC ID	ZNFV930		
Form Factor	Portable Tablet		
Frequency Range of each LTE transmission band	LTE Band 12 (699.7 - 715.3 MHz)		
	LTE Band 17 (706.5 - 713.5 MHz)		
	LTE Band 5 (Cell) (824.7 - 848.3 MHz)		
	LTE Band 4 (AWS) (1710.7 - 1754.3 MHz)		
	LTE Band 2 (PCS) (1850.7 - 1909.3 MHz)		
	LTE Band 7 (2502.5 - 2567.5 MHz)		
Channel Bandwidths	LTE Band 12: 1.4 MHz, 3 MHz, 5 MHz, 10 MHz		
	LTE Band 17: 5 MHz, 10 MHz		
	LTE Band 5 (Cell): 1.4 MHz, 3 MHz, 5 MHz, 10 MHz		
	LTE Band 4 (AWS): 1.4 MHz, 3 MHz, 5 MHz, 10 MHz, 15 MHz, 20 MHz		
	LTE Band 2 (PCS): 1.4 MHz, 3 MHz, 5 MHz, 10 MHz, 15 MHz, 20 MHz		
	LTE Band 7: 5 MHz, 10 MHz, 15 MHz, 20 MHz		
Channel Numbers and Frequencies (MHz)	Low	Mid	High
LTE Band 12: 1.4 MHz	699.7 (23017)	707.5 (23095)	715.3 (23173)
LTE Band 12: 3 MHz	700.5 (23025)	707.5 (23095)	714.5 (23165)
LTE Band 12: 5 MHz	701.5 (23035)	707.5 (23095)	713.5 (23155)
LTE Band 12: 10 MHz	704 (23060)	707.5 (23095)	711 (23130)
LTE Band 17: 5 MHz	706.5 (23755)	710 (23790)	713.5 (23825)
LTE Band 17: 10 MHz	709 (23780)	710 (23790)	711 (23800)
LTE Band 5 (Cell): 1.4 MHz	824.7 (20407)	836.5 (20525)	848.3 (20643)
LTE Band 5 (Cell): 3 MHz	825.5 (20415)	836.5 (20525)	847.5 (20635)
LTE Band 5 (Cell): 5 MHz	826.5 (20425)	836.5 (20525)	846.5 (20625)
LTE Band 5 (Cell): 10 MHz	829 (20450)	836.5 (20525)	844 (20600)
LTE Band 4 (AWS): 1.4 MHz	1710.7 (19957)	1732.5 (20175)	1754.3 (20393)
LTE Band 4 (AWS): 3 MHz	1711.5 (19965)	1732.5 (20175)	1753.5 (20385)
LTE Band 4 (AWS): 5 MHz	1712.5 (19975)	1732.5 (20175)	1752.5 (20375)
LTE Band 4 (AWS): 10 MHz	1715 (20000)	1732.5 (20175)	1750 (20350)
LTE Band 4 (AWS): 15 MHz	1717.5 (20025)	1732.5 (20175)	1747.5 (20325)
LTE Band 4 (AWS): 20 MHz	1720 (20050)	1732.5 (20175)	1745 (20300)
LTE Band 2 (PCS): 1.4 MHz	1850.7 (18607)	1880 (18900)	1909.3 (19193)
LTE Band 2 (PCS): 3 MHz	1851.5 (18615)	1880 (18900)	1908.5 (19185)
LTE Band 2 (PCS): 5 MHz	1852.5 (18625)	1880 (18900)	1907.5 (19175)
LTE Band 2 (PCS): 10 MHz	1855 (18650)	1880 (18900)	1905 (19150)
LTE Band 2 (PCS): 15 MHz	1857.5 (18675)	1880 (18900)	1902.5 (19125)
LTE Band 2 (PCS): 20 MHz	1860 (18700)	1880 (18900)	1900 (19100)
LTE Band 7: 5 MHz	2502.5 (20775)	2535 (21100)	2567.5 (21425)
LTE Band 7: 10 MHz	2505 (20800)	2535 (21100)	2565 (21400)
LTE Band 7: 15 MHz	2507.5 (20825)	2535 (21100)	2562.5 (21375)
LTE Band 7: 20 MHz	2510 (20850)	2535 (21100)	2560 (21350)
UE Category	4		
Modulations Supported in UL	QPSK, 16QAM		
LTE MPR Permanently implemented per 3GPP TS 36.101 section 6.2.3-6.2.5? (manufacturer attestation to be provided)	YES		
A-MPR (Additional MPR) disabled for SAR Testing?	YES		
LTE Carrier Aggregation Possible Combinations	LTE B4 (PCC) + LTE B17 (SCC)	LTE B2 (PCC) + LTE B17 (SCC)	LTE B4 (PCC) + LTE B12 (SCC)
	5MHz (B4) + 5MHz (B17)	5MHz (B2) + 5MHz (B17)	5MHz (B4) + 5MHz (B12)
	5MHz (B4) + 10MHz (B17)	5MHz (B2) + 10MHz (B17)	5MHz (B4) + 10MHz (B12)
	10MHz (B4) + 5MHz (B17)	10MHz (B2) + 5MHz (B17)	10MHz (B4) + 5MHz (B12)
	10MHz (B4) + 10MHz (B17)	10MHz (B2) + 10MHz (B17)	10MHz (B4) + 10MHz (B12)
	LTE B17 (PCC) + LTE B2 (SCC)	LTE B17 (PCC) + LTE B4 (SCC)	LTE B12 (PCC) + LTE B4 (SCC)
	5MHz (B17) + 5MHz (B2)	5MHz (B17) + 5MHz (B4)	5MHz (B12) + 5MHz (B4)
	5MHz (B17) + 10MHz (B2)	5MHz (B17) + 10MHz (B4)	5MHz (B12) + 10MHz (B4)
	10MHz (B17) + 5MHz (B2)	10MHz (B17) + 5MHz (B4)	10MHz (B12) + 5MHz (B4)
	10MHz (B17) + 10MHz (B2)	10MHz (B17) + 10MHz (B4)	10MHz (B12) + 10MHz (B4)
	LTE B2 (PCC) + LTE B29 (SCC)	LTE B4 (PCC) + LTE B29 (SCC)	
	5MHz (B2) + 5MHz (B29)	5MHz (B4) + 5MHz (B29)	
	5MHz (B2) + 10MHz (B29)	5MHz (B4) + 10MHz (B29)	
	10MHz (B2) + 5MHz (B29)	10MHz (B4) + 5MHz (B29)	
	10MHz (B2) + 10MHz (B29)	10MHz (B4) + 10MHz (B29)	
LTE Release 10 Additional Information	This device does not support full CA features on 3GPP Release 10. It supports a maximum of 2 carriers in the downlink. All uplink communications are identical to the Release 8 Specifications. Uplink communications are done on the PCC. The following LTE Release 10 Features are not supported: Relay, HetNet, Enhanced MIMO, eICI, WiFi Offloading, MDH, eMBMA, Cross-Carrier Scheduling, Enhanced SC-FDMA.		

FCC ID: ZNFV930	 PCTEST ENGINEERING LABORATORY, INC.	SAR EVALUATION REPORT	 LG	Reviewed by: Quality Manager
Document S/N: OY1506161253-R2.ZNF	Test Dates: 06/17/15 - 06/23/15	DUT Type: Portable Tablet		Page 8 of 88

3 INTRODUCTION

The FCC and Industry Canada have adopted the guidelines for evaluating the environmental effects of radio frequency (RF) radiation in ET Docket 93-62 on Aug. 6, 1996 and Health Canada Safety Code 6 to protect the public and workers from the potential hazards of RF emissions due to FCC-regulated portable devices. [1]

The safety limits used for the environmental evaluation measurements are based on the criteria published by the American National Standards Institute (ANSI) for localized specific absorption rate (SAR) in IEEE/ANSI C95.1-1992 Standard for Safety Levels with Respect to Human Exposure to Radio Frequency Electromagnetic Fields, 3 kHz to 300 GHz [3] and Health Canada RF Exposure Guidelines Safety Code 6 [22]. The measurement procedure described in IEEE/ANSI C95.3-2002 Recommended Practice for the Measurement of Potentially Hazardous Electromagnetic Fields - RF and Microwave [4] is used for guidance in measuring the Specific Absorption Rate (SAR) due to the RF radiation exposure from the Equipment Under Test (EUT). These criteria for SAR evaluation are similar to those recommended by the International Committee for Non-Ionizing Radiation Protection (ICNIRP) in Biological Effects and Exposure Criteria for Radiofrequency Electromagnetic Fields,” Report No. Vol 74. SAR is a measure of the rate of energy absorption due to exposure to an RF transmitting source. SAR values have been related to threshold levels for potential biological hazards.

3.1 SAR Definition

Specific Absorption Rate is defined as the time derivative (rate) of the incremental energy (dU) absorbed by (dissipated in) an incremental mass (dm) contained in a volume element (dV) of a given density (ρ). It is also defined as the rate of RF energy absorption per unit mass at a point in an absorbing body (see Equation 3-1).

Equation 3-1
SAR Mathematical Equation

$$SAR = \frac{d}{dt} \left(\frac{dU}{dm} \right) = \frac{d}{dt} \left(\frac{dU}{\rho dv} \right)$$



SAR is expressed in units of Watts per Kilogram (W/kg).

$$SAR = \frac{\sigma \cdot E^2}{\rho}$$

where:

- σ = conductivity of the tissue-simulating material (S/m)
- ρ = mass density of the tissue-simulating material (kg/m³)
- E = Total RMS electric field strength (V/m)

NOTE: The primary factors that control rate of energy absorption were found to be the wavelength of the incident field in relation to the dimensions and geometry of the irradiated organism, the orientation of the organism in relation to the polarity of field vectors, the presence of reflecting surfaces, and whether conductive contact is made by the organism with a ground plane.[6]

FCC ID: ZNFV930	 PCTEST <small>ENGINEERING LABORATORY, INC.</small>	SAR EVALUATION REPORT		Reviewed by: Quality Manager
Document S/N: OY1506161253-R2.ZNF	Test Dates: 06/17/15 - 06/23/15	DUT Type: Portable Tablet	Page 9 of 88	

4 DOSIMETRIC ASSESSMENT

4.1 Measurement Procedure

The evaluation was performed using the following procedure compliant to FCC KDB Publication 865664 D01v01 and IEEE 1528-2013:

1. The SAR distribution at the exposed side of the head or body was measured at a distance no greater than 5.0 mm from the inner surface of the shell. The area covered the entire dimension of the device-head and body interface and the horizontal grid resolution was determined per FCC KDB Publication 865664 D01v01 (See Table 4-1) and IEEE 1528-2013.
2. The point SAR measurement was taken at the maximum SAR region determined from Step 1 to enable the monitoring of SAR fluctuations/drifts during the 1g/10g cube evaluation. SAR at this fixed point was measured and used as a reference value.
3. Based on the area scan data, the peak of the region with maximum SAR was determined by spline interpolation. Around this point, a volume was assessed according to the measurement resolution and volume size requirements of FCC KDB Publication 865664 D01v01 (See Table 4-1) and IEEE 1528-2013. On the basis of this data set, the spatial peak SAR value was evaluated with the following procedure (see references or the DASy manual online for more details):
 - a. SAR values at the inner surface of the phantom are extrapolated from the measured values along the line away from the surface with spacing no greater than that in Table 4-1. The extrapolation was based on a least-squares algorithm. A polynomial of the fourth order was calculated through the points in the z-axis (normal to the phantom shell).
 - b. After the maximum interpolated values were calculated between the points in the cube, the SAR was averaged over the spatial volume (1g or 10g) using a 3D-Spline interpolation algorithm. The 3D-spline is composed of three one-dimensional splines with the “Not a knot” condition (in x, y, and z directions). The volume was then integrated with the trapezoidal algorithm. One thousand points (10 x 10 x 10) were obtained through interpolation, in order to calculate the averaged SAR.
 - c. All neighboring volumes were evaluated until no neighboring volume with a higher average value was found.
4. The SAR reference value, at the same location as step 2, was re-measured after the zoom scan was complete to calculate the SAR drift. If the drift deviated by more than 5%, the SAR test and drift measurements were repeated.

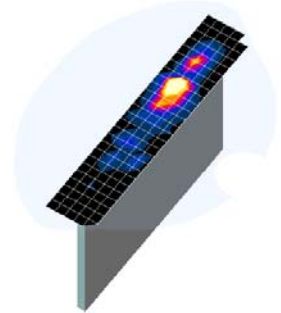



Figure 4-1
Sample SAR Area Scan

Table 4-1
Area and Zoom Scan Resolutions per FCC KDB Publication 865664 D01v01*

Frequency	Maximum Area Scan Resolution (mm) ($\Delta x_{\text{area}}, \Delta y_{\text{area}}$)	Maximum Zoom Scan Resolution (mm) ($\Delta x_{\text{zoom}}, \Delta y_{\text{zoom}}$)	Maximum Zoom Scan Spatial Resolution (mm)			Minimum Zoom Scan Volume (mm) (x, y, z)
			Uniform Grid	Graded Grid		
			$\Delta z_{\text{zoom}}(n)$	$\Delta z_{\text{zoom}}(1)^*$	$\Delta z_{\text{zoom}}(n>1)^*$	
≤ 2 GHz	≤ 15	≤ 8	≤ 5	≤ 4	≤ 1.5* $\Delta z_{\text{zoom}}(n-1)$	≥ 30
2-3 GHz	≤ 12	≤ 5	≤ 5	≤ 4	≤ 1.5* $\Delta z_{\text{zoom}}(n-1)$	≥ 30
3-4 GHz	≤ 12	≤ 5	≤ 4	≤ 3	≤ 1.5* $\Delta z_{\text{zoom}}(n-1)$	≥ 28
4-5 GHz	≤ 10	≤ 4	≤ 3	≤ 2.5	≤ 1.5* $\Delta z_{\text{zoom}}(n-1)$	≥ 25
5-6 GHz	≤ 10	≤ 4	≤ 2	≤ 2	≤ 1.5* $\Delta z_{\text{zoom}}(n-1)$	≥ 22

*Also compliant to IEEE 1528-2013 Table 6

FCC ID: ZNFV930	 SAR EVALUATION REPORT 		Reviewed by: Quality Manager
Document S/N: OY1506161253-R2.ZNF	Test Dates: 06/17/15 - 06/23/15	DUT Type: Portable Tablet	Page 10 of 88

© 2015 PCTEST Engineering Laboratory, Inc.

REV 16.0 M
06/12/2015

(c) 2015 PCTEST Engineering Laboratory, Inc. All rights reserved. Unless otherwise specified, no part of this report may be reproduced or utilized in any part, form or by any means, electronic or mechanical, including photocopying and microfilm, without permission in writing from PCTEST Engineering Laboratory, Inc. If you have any questions about this international copyright or have an enquiry about obtaining additional rights to this report or assembly of contents thereof, please contact info@pctestlab.com.

5 SAR TESTING PROCEDURES

5.1 SAR Testing for Tablet per KDB Publication 616217 D04v01

This device can be used also in full sized tablet exposure conditions, due to its size. Per FCC KDB 616217, the back surface and edges of the tablet should be tested for SAR compliance with the tablet touching the phantom. The SAR Exclusion Threshold in KDB 447498 D01v05 can be applied to determine SAR test exclusion for adjacent edge configurations. The closest distance from the antenna to an adjacent tablet edge is used to determine if SAR testing is required for the adjacent edges, with the adjacent edge positioned against the phantom and the edge containing the antenna positioned perpendicular to the phantom.



5.2 Power Reduction Considerations

The device uses a power reduction mechanism in certain use conditions for Main Antenna operations when the device is used close to the user's body

While the device's antenna is within a certain distance of the user, the sensor activates and reduces the maximum output power allowed. However, the sensor is not active when the device is moved beyond the sensor triggering distance and the maximum output power is no longer limited. Therefore, an additional exposure condition is needed in the vicinity of the triggering distance to ensure SAR is compliant when the device is allowed to operate at a non-reduced output power level.

FCC KDB 616217 D04 Section 6 was used as a guideline for selecting SAR test distances for this device at these additional exposure conditions. Since the sensor activation distance for the back side of the device for UMTS 850, LTE B5/12/7 is 17 mm, a conservative distance of 16 mm was tested for SAR on the back side at maximum power for UMTS 850, LTE B5/12/7. Since the sensor activation distance for the back side of the device for UMTS 1900, LTE B2/4 is 13 mm, a conservative distance of 12 mm was tested for SAR on the back side at maximum power for UMTS 1900, LTE B2/4. Since the sensor activation distance for the top edge of the device is 20 mm for UMTS850 and LTE B5/12/7, a conservative distance of 19 mm was tested for SAR for the top edge at maximum power for UMTS850 and LTE B5/12/7. Since the sensor activation distance for the right edge of the device is 15 mm for UMTS1900 and LTE B2/4, a conservative distance of 14 mm was tested for SAR on the right edge at maximum power for UMTS1900 and LTE B2/4. Sensor triggering distance summary data is included in Appendix G.

The sensor is designed to support sufficient detection range and sensitivity to cover regions of the sensors in all applicable directions since the sensor entirely covers the antennas.

FCC ID: ZNFV930	 PCTEST ENGINEERING LABORATORY, INC.	SAR EVALUATION REPORT	 LG	Reviewed by: Quality Manager
Document S/N: OY1506161253-R2.ZNF	Test Dates: 06/17/15 - 06/23/15	DUT Type: Portable Tablet		Page 11 of 88

© 2015 PCTEST Engineering Laboratory, Inc.

REV 16.0 M
06/12/2015

(c) 2015 PCTEST Engineering Laboratory, Inc. All rights reserved. Unless otherwise specified, no part of this report may be reproduced or utilized in any part, form or by any means, electronic or mechanical, including photocopying and microfilm, without permission in writing from PCTEST Engineering Laboratory, Inc. If you have any questions about this international copyright or have an enquiry about obtaining additional rights to this report or assembly of contents thereof, please contact info@pctestlab.com.

6 RF EXPOSURE LIMITS

6.1 Uncontrolled Environment

UNCONTROLLED ENVIRONMENTS are defined as locations where there is the exposure of individuals who have no knowledge or control of their exposure. The general population/uncontrolled exposure limits are applicable to situations in which the general public may be exposed or in which persons who are exposed as a consequence of their employment may not be made fully aware of the potential for exposure or cannot exercise control over their exposure. Members of the general public would come under this category when exposure is not employment-related; for example, in the case of a wireless transmitter that exposes persons in its vicinity.



6.2 Controlled Environment

CONTROLLED ENVIRONMENTS are defined as locations where there is exposure that may be incurred by persons who are aware of the potential for exposure, (i.e. as a result of employment or occupation). In general, occupational/controlled exposure limits are applicable to situations in which persons are exposed as a consequence of their employment, who have been made fully aware of the potential for exposure and can exercise control over their exposure. This exposure category is also applicable when the exposure is of a transient nature due to incidental passage through a location where the exposure levels may be higher than the general population/uncontrolled limits, but the exposed person is fully aware of the potential for exposure and can exercise control over his or her exposure by leaving the area or by some other appropriate means.

Table 6-1
SAR Human Exposure Specified in ANSI/IEEE C95.1-1992 and Health Canada Safety Code 6

HUMAN EXPOSURE LIMITS		
	UNCONTROLLED ENVIRONMENT <i>General Population</i> (W/kg) or (mW/g)	CONTROLLED ENVIRONMENT <i>Occupational</i> (W/kg) or (mW/g)
Peak Spatial Average SAR Head	1.6	8.0
Whole Body SAR	0.08	0.4
Peak Spatial Average SAR Hands, Feet, Ankle, Wrists, etc.	4.0	20

1. The Spatial Peak value of the SAR averaged over any 1 gram of tissue (defined as a tissue volume in the shape of a cube) and over the appropriate averaging time.
2. The Spatial Average value of the SAR averaged over the whole body.
3. The Spatial Peak value of the SAR averaged over any 10 grams of tissue (defined as a tissue volume in the shape of a cube) and over the appropriate averaging time.

FCC ID: ZNFV930	 PCTEST ENGINEERING LABORATORY, INC.	SAR EVALUATION REPORT	 LG	Reviewed by: Quality Manager
Document S/N: OY1506161253-R2.ZNF	Test Dates: 06/17/15 - 06/23/15	DUT Type: Portable Tablet	Page 12 of 88	

7 FCC MEASUREMENT PROCEDURES

Power measurements for licensed transmitters are performed using a base station simulator under digital average power.

7.1 Measured and Reported SAR

Per FCC KDB Publication 447498 D01v05, when SAR is not measured at the maximum power level allowed for production units, the results must be scaled to the maximum tune-up tolerance limit according to the power applied to the individual channels tested to determine compliance. For simultaneous transmission, the measured aggregate SAR must be scaled according to the sum of the differences between the maximum tune-up tolerance and actual power used to test each transmitter. When SAR is measured at or scaled to the maximum tune-up tolerance limit, the results are referred to as *reported* SAR. The highest *reported* SAR results are identified on the grant of equipment authorization according to procedures in KDB 690783 D01v01r02.

7.2 3G SAR Test Reduction Procedure

In FCC KDB Publication 941225 D01v03, certain transmission modes within a frequency band and wireless mode evaluated for SAR are defined as primary modes. The equivalent modes considered for SAR test reduction are denoted as secondary modes. When the maximum output power including tune-up tolerance specified for production units in a secondary mode is ≤ 0.25 dB higher than the primary mode or when the highest reported SAR of the primary mode, scaled by the ratio of specified maximum output power and tune-up tolerance of secondary to primary mode, is ≤ 1.2 W/kg, SAR measurements are not required for the secondary mode. These criteria are referred to as the 3G SAR test reduction procedure. When the 3G SAR test reduction procedure is not satisfied, SAR measurements are additionally required for the secondary mode.

7.3 Procedures Used to Establish RF Signal for SAR



The following procedures are according to FCC KDB Publication 941225 D01v03 “3G SAR Measurement Procedures.”

The device is placed into a simulated call using a base station simulator in a RF shielded chamber. Establishing connections in this manner ensure a consistent means for testing SAR and are recommended for evaluating SAR [4]. Devices under test are evaluated prior to testing, with a fully charged battery and were configured to operate at maximum output power. In order to verify that the device is tested throughout the SAR test at maximum output power, the SAR measurement system measures a “point SAR” at an arbitrary reference point at the start and end of the 1 gram SAR evaluation, to assess for any power drifts during the evaluation. If the power drift deviates by more than 5%, the SAR test and drift measurements are repeated.

7.4 SAR Measurement Conditions for UMTS

7.4.1 Output Power Verification

Maximum output power is verified on the High, Middle and Low channels according to the general descriptions in section 5.2 of 3GPP TS 34.121, using the appropriate RMC with TPC (transmit power control) set to all “1s” or applying the required inner loop power control procedures to maintain maximum output power while HSUPA is active. Results for all applicable physical channel configurations (DPCCCH, DPDCHn and spreading codes, HS-DPCCCH etc) are tabulated in this test report. All configurations that are not supported by the DUT or cannot be measured due to technical or equipment limitations are identified.

FCC ID: ZNFV930	 PCTEST ENGINEERING LABORATORY, INC.	SAR EVALUATION REPORT	 LG	Reviewed by: Quality Manager
Document S/N: OY1506161253-R2.ZNF	Test Dates: 06/17/15 - 06/23/15	DUT Type: Portable Tablet		Page 13 of 88

© 2015 PCTEST Engineering Laboratory, Inc.

REV 16.0 M
06/12/2015

(c) 2015 PCTEST Engineering Laboratory, Inc. All rights reserved. Unless otherwise specified, no part of this report may be reproduced or utilized in any part, form or by any means, electronic or mechanical, including photocopying and microfilm, without permission in writing from PCTEST Engineering Laboratory, Inc. If you have any questions about this international copyright or have an enquiry about obtaining additional rights to this report or assembly of contents thereof, please contact info@pctestlab.com.

7.4.2 Body SAR Measurements

SAR for body exposure configurations is measured using the 12.2 kbps RMC with the TPC bits all “1s”. The 3G SAR test reduction procedure is applied to other spreading codes and multiple DPDCH_n configurations supported by the tablet with 12.2 kbps RMC as the primary mode. Otherwise, SAR is measured using an applicable RMC configuration with the corresponding spreading code or DPDCH_n, for the highest reported SAR configuration in 12.2 kbps RMC.

7.4.3 SAR Measurements with Rel 5 HSDPA

The 3G SAR test reduction procedure is applied to HSDPA body configurations with 12.2 kbps RMC as the primary mode. Otherwise, Body SAR for HSDPA is measured using an FRC with H-Set 1 in Sub-test 1 and a 12.2 kbps RMC configured in Test Loop Mode 1, for the highest reported SAR configuration in 12.2 kbps RMC without HSDPA. Tablets with both HSDPA and HSUPA are tested according to Release 6 HSPA test procedures.

7.4.4 SAR Measurements with Rel 6 HSUPA

The 3G SAR test reduction procedure is applied to HSPA (HSUPA/HSDPA with RMC) body configurations with 12.2 kbps RMC as the primary mode. Otherwise, Body SAR for HSPA is measured with E-DCH Sub-test 5, using H-Set 1 and QPSK for FRC and a 12.2 kbps RMC configured in Test Loop Mode 1 and power control algorithm 2, according to the highest reported body SAR configuration in 12.2 kbps RMC without HSPA.

When VOIP applies to head exposure, the 3G SAR test reduction procedure is applied with 12.2 kbps RMC as the primary mode; otherwise, the same HSPA configuration used for body SAR measurements are applied to head exposure testing.

7.5 SAR Measurement Conditions for LTE

LTE modes are tested according to FCC KDB 941225 D05v02r03 publication. Establishing connections with base station simulators ensure a consistent means for testing SAR and are recommended for evaluating SAR [4]. The R&S CMW500 or Anritsu MT8820C simulators are used for LTE output power measurements and SAR testing. Closed loop power control was used so the UE transmits with maximum output power during SAR testing. SAR tests were performed with the same number of RB and RB offsets transmitting on all TTI frames (maximum TTI).

7.5.1 Spectrum Plots for RB Configurations



A properly configured base station simulator was used for SAR tests and power measurements. Therefore, spectrum plots for RB configurations were not required to be included in this report.

7.5.2 MPR

MPR is permanently implemented for this device by the manufacturer. The specific manufacturer target MPR is indicated alongside the SAR results. MPR is enabled for this device, according to 3GPP TS36.101 Section 6.2.3 – 6.2.5 under Table 6.2.3-1.

7.5.3 A-MPR

A-MPR (Additional MPR) has been disabled for all SAR tests by setting NS=01 on the base station simulator.

FCC ID: ZNFV930	 PCTEST ENGINEERING LABORATORY, INC.	SAR EVALUATION REPORT	 LG	Reviewed by: Quality Manager
Document S/N: OY1506161253-R2.ZNF	Test Dates: 06/17/15 - 06/23/15	DUT Type: Portable Tablet	Page 14 of 88	

© 2015 PCTEST Engineering Laboratory, Inc.

REV 16.0 M
06/12/2015

(c) 2015 PCTEST Engineering Laboratory, Inc. All rights reserved. Unless otherwise specified, no part of this report may be reproduced or utilized in any part, form or by any means, electronic or mechanical, including photocopying and microfilm, without permission in writing from PCTEST Engineering Laboratory, Inc. If you have any questions about this international copyright or have an enquiry about obtaining additional rights to this report or assembly of contents thereof, please contact info@pctestlab.com.

7.5.4 Required RB Size and RB Offsets for SAR Testing

According to FCC KDB 941225 D05v02r03:

- a. Per Section 4.2.1, SAR is required for QPSK 1 RB Allocation for the largest bandwidth
 - i. The required channel and offset combination with the highest maximum output power is required for SAR.
 - ii. When the reported SAR is ≤ 0.8 W/kg, testing of the remaining RB offset configurations and required test channels is not required. Otherwise, SAR is required for the remaining required test channels using the RB offset configuration with highest output power for that channel.
 - iii. When the reported SAR for a required test channel is > 1.45 W/kg, SAR is required for all RB offset configurations for that channel.
- b. Per Section 4.2.2, SAR is required for 50% RB allocation using the largest bandwidth following the same procedures outlined in Section 4.2.1.
- c. Per Section 4.2.3, QPSK SAR is not required for the 100% allocation when the highest maximum output power for the 100% allocation is less than the highest maximum output power of the 1 RB and 50% RB allocations and the reported SAR for the 1 RB and 50% RB allocations is < 0.8 W/kg.
- d. Per Section 4.2.4 and 4.3, SAR tests for higher order modulations and lower bandwidths configurations are not required when the conducted power of the required test configurations determined by Sections 4.2.1 through 4.2.3 is less than or equal to $\frac{1}{2}$ dB higher than the equivalent configuration using QPSK modulation and when the QPSK SAR for those configurations is < 1.45 W/kg.

7.5.5 Downlink Carrier Aggregation



LTE Carrier Aggregation (CA) measurements are made in accordance to 3GPP TS 36.521-1 V10.4.0 (2012-12). The RRC connection is only handled by one cell, the Primary component carrier (PCC) for downlink and uplink communications. After making a data connection to the PCC, the UE device adds the Secondary component carrier (SCC) on the downlink only. All uplink communications and acknowledgements remain identical to release 8 specifications on the PCC. Additional output powers are measured using two carriers in the downlink for the release 8 configurations with the highest output power among all channels, RB configurations and bandwidths for each uplink band. Per FCC KDB Publication 941225 D05A v01r01, no SAR measurements are required when the average output power with downlink carrier aggregation active is not more than 0.25 dB higher than the average output power with downlink carrier aggregation inactive.

7.6 SAR Testing with 802.11 Transmitters

The normal network operating configurations of 802.11 transmitters are not suitable for SAR measurements. Unpredictable fluctuations in network traffic and antenna diversity conditions can introduce undesirable variations in SAR results. The SAR for these devices should be measured using chipset based test mode software to ensure the results are consistent and reliable. See KDB Publication 248227 D01v02r01r01 for more details.

7.6.1 General Device Setup

Chipset based test mode software is hardware dependent and generally varies among manufacturers. The device operating parameters established in test mode for SAR measurements must be identical to those programmed in production units, including output power levels, amplifier gain settings and other RF performance tuning parameters.

FCC ID: ZNFV930	 PCTEST ENGINEERING LABORATORY, INC.	SAR EVALUATION REPORT	 LG	Reviewed by: Quality Manager
Document S/N: OY1506161253-R2.ZNF	Test Dates: 06/17/15 - 06/23/15	DUT Type: Portable Tablet		Page 15 of 88

© 2015 PCTEST Engineering Laboratory, Inc.

REV 16.0 M
06/12/2015

(c) 2015 PCTEST Engineering Laboratory, Inc. All rights reserved. Unless otherwise specified, no part of this report may be reproduced or utilized in any part, form or by any means, electronic or mechanical, including photocopying and microfilm, without permission in writing from PCTEST Engineering Laboratory, Inc. If you have any questions about this international copyright or have an enquiry about obtaining additional rights to this report or assembly of contents thereof, please contact info@pctestlab.com.

A periodic duty factor is required for current generation SAR systems to measure SAR. When 802.11 frame gaps are accounted for in the transmission, a maximum transmission duty factor of 92 - 96% is typically achievable in most test mode configurations. A minimum transmission duty factor of 85% is required to avoid certain hardware and device implementation issues related to wide range SAR scaling. The reported SAR is scaled to 100% transmission duty factor to determine compliance at the maximum tune-up tolerance limit.

7.6.2 U-NII-1 and U-NII-2A

For devices that operate in both U-NII-1 and U-NII-2A bands, when the same maximum output power is specified for both bands, SAR measurement using OFDM SAR test procedures is not required for U-NII-1 unless the highest reported SAR for U-NII-2A is > 1.2 W/kg. When different maximum output powers are specified for the bands, SAR measurement for the U-NII band with the lower maximum output power is not required unless the highest reported SAR for the U-NII band with the higher maximum output power, adjusted by the ratio of lower to higher specified maximum output power for the two bands, is > 1.2 W/kg.

7.6.3 U-NII-2C and U-NII-3

The frequency range covered by U-NII-2C and U-NII-3 is 380 MHz (5.47 – 5.85 GHz), which requires a minimum of at least two SAR probe calibration frequency points to support SAR measurements. When Terminal Doppler Weather Radar (TDWR) restriction applies, the channels at 5.60 – 5.65 GHz in U-NII-2C band must be disabled with acceptable mechanisms and documented in the equipment certification.



Unless band gap channels are permanently disabled, SAR must be considered for these channels.

7.6.4 2.4 GHz SAR Test Requirements

SAR is measured for 2.4 GHz 802.11b DSSS using either the fixed test position or, when applicable, the initial test position procedure. SAR test reduction is determined according to the following:

- 1) When the reported SAR of the highest measured maximum output power channel for the exposure configuration is ≤ 0.8 W/kg, no further SAR testing is required for 802.11b DSSS in that exposure configuration.
- 2) When the reported SAR is > 0.8 W/kg, SAR is required for that position using the next highest measured output power channel. When any reported SAR is > 1.2 W/kg, SAR is required for the third channel; i.e., all channels require testing.

2.4 GHz 802.11 g/n OFDM are additionally evaluated for SAR if the highest reported SAR for 802.11b, adjusted by the ratio of the OFDM to DSSS specified maximum output power, is > 1.2 W/kg. When SAR is required for OFDM modes in 2.4 GHz band, the Initial Test Configuration Procedures should be followed.

FCC ID: ZNFV930	 PCTEST ENGINEERING LABORATORY, INC.	SAR EVALUATION REPORT	 LG	Reviewed by: Quality Manager
Document S/N: OY1506161253-R2.ZNF	Test Dates: 06/17/15 - 06/23/15	DUT Type: Portable Tablet		Page 16 of 88

7.6.5 OFDM Transmission Mode and SAR Test Channel Selection

For the 2.4 GHz and 5 GHz bands, when the same maximum output power was specified for multiple OFDM transmission mode configurations in a frequency band or aggregated band, SAR is measured using the configuration with the largest channel bandwidth, lowest order modulation and lowest data rate. When the maximum output power of a channel is the same for equivalent OFDM configurations; for example, 802.11a, 802.11n and 802.11ac or 802.11g and 802.11n with the same channel bandwidth, modulation and data rate etc., the lower order 802.11 mode i.e., 802.11a, then 802.11n and 802.11ac or 802.11g then 802.11n, is used for SAR measurement. When the maximum output power are the same for multiple test channels, either according to the default or additional power measurement requirements, SAR is measured using the channel closest to the middle of the frequency band or aggregated band. When there are multiple channels with the same maximum output power, SAR is measured using the higher number channel.



7.6.6 Initial Test Configuration Procedure

For OFDM, in both 2.4 and 5 GHz bands, an initial test configuration is determined for each frequency band and aggregated band, according to the transmission mode with the highest maximum output power specified for SAR measurements. When the same maximum output power is specified for multiple OFDM transmission mode configurations in a frequency band or aggregated band, SAR is measured using the configuration(s) with the largest channel bandwidth, lowest order modulation, and lowest data rate. The channel of the transmission mode with the highest average RF output conducted power will be the initial test configuration.

When the reported SAR is ≤ 0.8 W/kg, no additional measurements on other test channels are required. Otherwise, SAR is evaluated using the subsequent highest average RF output channel until the reported SAR result is ≤ 1.2 W/kg or all channels are measured. When there are multiple untested channels having the same subsequent highest average RF output power, the channel with higher frequency from the lowest 802.11 mode is considered for SAR measurements (See Section 0).

7.6.7 Subsequent Test Configuration Procedures

For OFDM configurations in each frequency band and aggregated band, SAR is evaluated for initial test configuration using the fixed test position or the initial test position procedure. When the highest reported SAR (for the initial test configuration), adjusted by the ratio of the specified maximum output power of the subsequent test configuration to initial test configuration, is ≤ 1.2 W/kg, no additional SAR tests for the subsequent test configurations are required.

FCC ID: ZNFV930	 SAR EVALUATION REPORT 		Reviewed by: Quality Manager
Document S/N: OY1506161253-R2.ZNF	Test Dates: 06/17/15 - 06/23/15	DUT Type: Portable Tablet	Page 17 of 88

8 RF CONDUCTED POWERS

8.1 UMTS Conducted Powers

Table 8-1
Maximum Average RF Output Powers

3GPP Release Version	Mode	3GPP 34.121 Subtest	Cellular Band [dBm]			PCS Band [dBm]			3GPP MPR [dB]
			4132	4183	4233	9262	9400	9538	
99	WCDMA	12.2 kbps RMC	23.87	23.97	23.89	23.92	24.00	23.98	-
6	HSDPA	Subtest 1	23.84	23.80	23.77	23.92	24.00	23.99	0
6		Subtest 2	23.79	23.81	23.79	23.89	23.99	23.91	0
6		Subtest 3	23.30	23.34	23.33	23.49	23.50	23.49	0.5
6		Subtest 4	23.24	23.33	23.32	23.46	23.48	23.47	0.5
6	HSUPA	Subtest 1	23.70	22.66	23.51	23.82	23.44	22.92	0
6		Subtest 2	22.50	22.73	22.39	22.67	22.90	22.76	2
6		Subtest 3	22.72	22.81	22.78	22.78	23.13	23.07	1
6		Subtest 4	23.75	23.74	23.70	23.91	24.00	23.97	2
6		Subtest 5	23.79	23.81	23.75	23.95	23.96	24.00	0



Table 8-2
Reduced Average RF Output Powers – Body at 0.0 cm

3GPP Release Version	Mode	3GPP 34.121 Subtest	Cellular Band [dBm]			PCS Band [dBm]			3GPP MPR [dB]
			4132	4183	4233	9262	9400	9538	
99	WCDMA	12.2 kbps RMC	18.40	18.40	18.38	12.43	12.40	12.38	-
6	HSDPA	Subtest 1	18.37	18.39	18.22	12.34	12.37	12.15	0
6		Subtest 2	18.33	18.37	18.36	12.40	12.39	12.18	0
6		Subtest 3	17.92	17.97	17.81	11.96	11.83	11.62	0.5
6		Subtest 4	17.85	18.00	17.89	11.90	11.83	12.00	0.5
6	HSUPA	Subtest 1	18.00	17.50	17.10	11.39	11.36	11.38	0
6		Subtest 2	16.69	16.57	16.74	10.57	10.67	10.70	2
6		Subtest 3	16.91	17.00	17.11	10.91	10.60	10.40	1
6		Subtest 4	18.30	18.08	18.28	12.00	12.24	12.08	2
6		Subtest 5	18.37	18.46	18.24	12.19	12.42	12.13	0

This Device does not support DC-HSDPA .



Figure 8-1
Power Measurement Setup

FCC ID: ZNFV930	 PCTEST <small>ENGINEERING LABORATORY, INC.</small>		SAR EVALUATION REPORT		Reviewed by: Quality Manager
Document S/N: OY1506161253-R2.ZNF	Test Dates: 06/17/15 - 06/23/15	DUT Type: Portable Tablet		Page 18 of 88	

8.2 LTE Conducted Powers

8.2.1 LTE Band 12

Table 8-3
LTE Band 12 Conducted Powers - 10 MHz Bandwidth
Maximum Power

	Frequency [MHz]	Channel	Bandwidth [MHz]	Modulation	RB Size	RB Offset	Conducted Power [dBm]	MPR Allowed per 3GPP [dB]	MPR [dB]
Mid	707.5	23095	10	QPSK	1	0	24.49	0	0
	707.5	23095	10	QPSK	1	25	24.33	0	0
	707.5	23095	10	QPSK	1	49	24.50	0	0
	707.5	23095	10	QPSK	25	0	23.33	0-1	1
	707.5	23095	10	QPSK	25	12	23.24	0-1	1
	707.5	23095	10	QPSK	25	25	23.28	0-1	1
	707.5	23095	10	QPSK	50	0	23.29	0-1	1
	707.5	23095	10	16QAM	1	0	23.50	0-1	1
	707.5	23095	10	16QAM	1	25	23.38	0-1	1
	707.5	23095	10	16QAM	1	49	23.39	0-1	1
	707.5	23095	10	16QAM	25	0	22.34	0-2	2
	707.5	23095	10	16QAM	25	12	22.28	0-2	2
	707.5	23095	10	16QAM	25	25	22.28	0-2	2
707.5	23095	10	16QAM	50	0	22.27	0-2	2	

Note: LTE Band 12 at 10 MHz bandwidth does not support three non-overlapping channels. Per KDB Publication 941225 D05v02, when a device supports overlapping channel assignment in a channel bandwidth configuration, the middle channel of the group of overlapping channels should be selected for testing.





FCC ID: ZNFV930	 PCTEST <small>ENGINEERING LABORATORY, INC.</small>	SAR EVALUATION REPORT		Reviewed by: Quality Manager
Document S/N: OY1506161253-R2.ZNF	Test Dates: 06/17/15 - 06/23/15	DUT Type: Portable Tablet		Page 19 of 88



Table 8-4
LTE Band 12 Conducted Powers - 5 MHz Bandwidth
Maximum Power

	Frequency [MHz]	Channel	Bandwidth [MHz]	Modulation	RB Size	RB Offset	Conducted Power [dBm]	MPR Allowed per 3GPP [dB]	MPR [dB]
Low	701.5	23035	5	QPSK	1	0	24.48	0	0
	701.5	23035	5	QPSK	1	12	24.31	0	0
	701.5	23035	5	QPSK	1	24	24.31	0	0
	701.5	23035	5	QPSK	12	0	23.34	0-1	1
	701.5	23035	5	QPSK	12	6	23.35	0-1	1
	701.5	23035	5	QPSK	12	13	23.27	0-1	1
	701.5	23035	5	QPSK	25	0	23.25	0-1	1
	701.5	23035	5	16-QAM	1	0	23.16	0-1	1
	701.5	23035	5	16-QAM	1	12	23.12	0-1	1
	701.5	23035	5	16-QAM	1	24	23.15	0-1	1
	701.5	23035	5	16-QAM	12	0	22.20	0-2	2
	701.5	23035	5	16-QAM	12	6	22.24	0-2	2
Mid	701.5	23035	5	16-QAM	12	13	22.10	0-2	2
	701.5	23035	5	16-QAM	25	0	22.32	0-2	2
	707.5	23095	5	QPSK	1	0	24.30	0	0
	707.5	23095	5	QPSK	1	12	24.10	0	0
	707.5	23095	5	QPSK	1	24	24.42	0	0
	707.5	23095	5	QPSK	12	0	23.16	0-1	1
	707.5	23095	5	QPSK	12	6	23.10	0-1	1
	707.5	23095	5	QPSK	12	13	23.18	0-1	1
	707.5	23095	5	QPSK	25	0	23.10	0-1	1
	707.5	23095	5	16-QAM	1	0	23.19	0-1	1
	707.5	23095	5	16-QAM	1	12	22.87	0-1	1
	707.5	23095	5	16-QAM	1	24	23.24	0-1	1
High	707.5	23095	5	16-QAM	12	0	22.09	0-2	2
	707.5	23095	5	16-QAM	12	6	21.99	0-2	2
	707.5	23095	5	16-QAM	12	13	22.13	0-2	2
	707.5	23095	5	16-QAM	25	0	22.16	0-2	2
	713.5	23155	5	QPSK	1	0	24.41	0	0
	713.5	23155	5	QPSK	1	12	24.37	0	0
	713.5	23155	5	QPSK	1	24	24.26	0	0
	713.5	23155	5	QPSK	12	0	23.16	0-1	1
	713.5	23155	5	QPSK	12	6	23.19	0-1	1
	713.5	23155	5	QPSK	12	13	23.27	0-1	1
	713.5	23155	5	QPSK	25	0	23.29	0-1	1
	713.5	23155	5	16-QAM	1	0	23.29	0-1	1
713.5	23155	5	16-QAM	1	12	23.22	0-1	1	
713.5	23155	5	16-QAM	1	24	23.04	0-1	1	
713.5	23155	5	16-QAM	12	0	22.10	0-2	2	
713.5	23155	5	16-QAM	12	6	22.14	0-2	2	
713.5	23155	5	16-QAM	12	13	22.21	0-2	2	
713.5	23155	5	16-QAM	25	0	22.26	0-2	2	

FCC ID: ZNFV930	 PCTEST <small>ENGINEERING LABORATORY, INC.</small>	SAR EVALUATION REPORT		Reviewed by: Quality Manager
Document S/N: OY1506161253-R2.ZNF	Test Dates: 06/17/15 - 06/23/15	DUT Type: Portable Tablet		Page 20 of 88

**Table 8-5
LTE Band 12 Conducted Powers - 3 MHz Bandwidth
Maximum Power**

	Frequency [MHz]	Channel	Bandwidth [MHz]	Modulation	RB Size	RB Offset	Conducted Power [dBm]	MPR Allowed per 3GPP [dB]	MPR [dB]
Low	700.5	23025	3	QPSK	1	0	24.38	0	0
	700.5	23025	3	QPSK	1	7	24.45	0	0
	700.5	23025	3	QPSK	1	14	24.36	0	0
	700.5	23025	3	QPSK	8	0	23.45	0-1	1
	700.5	23025	3	QPSK	8	4	23.37	0-1	1
	700.5	23025	3	QPSK	8	7	23.36	0-1	1
	700.5	23025	3	QPSK	15	0	23.32	0-1	1
	700.5	23025	3	16-QAM	1	0	23.49	0-1	1
	700.5	23025	3	16-QAM	1	7	23.38	0-1	1
	700.5	23025	3	16-QAM	1	14	23.33	0-1	1
	700.5	23025	3	16-QAM	8	0	22.46	0-2	2
	700.5	23025	3	16-QAM	8	4	22.35	0-2	2
700.5	23025	3	16-QAM	8	7	22.38	0-2	2	
700.5	23025	3	16-QAM	15	0	22.25	0-2	2	
Mid	707.5	23095	3	QPSK	1	0	24.36	0	0
	707.5	23095	3	QPSK	1	7	24.21	0	0
	707.5	23095	3	QPSK	1	14	24.46	0	0
	707.5	23095	3	QPSK	8	0	23.30	0-1	1
	707.5	23095	3	QPSK	8	4	23.01	0-1	1
	707.5	23095	3	QPSK	8	7	22.95	0-1	1
	707.5	23095	3	QPSK	15	0	23.10	0-1	1
	707.5	23095	3	16-QAM	1	0	23.46	0-1	1
	707.5	23095	3	16-QAM	1	7	23.33	0-1	1
	707.5	23095	3	16-QAM	1	14	23.50	0-1	1
	707.5	23095	3	16-QAM	8	0	22.30	0-2	2
	707.5	23095	3	16-QAM	8	4	22.07	0-2	2
707.5	23095	3	16-QAM	8	7	21.96	0-2	2	
707.5	23095	3	16-QAM	15	0	22.08	0-2	2	
High	714.5	23165	3	QPSK	1	0	24.42	0	0
	714.5	23165	3	QPSK	1	7	24.50	0	0
	714.5	23165	3	QPSK	1	14	24.37	0	0
	714.5	23165	3	QPSK	8	0	23.26	0-1	1
	714.5	23165	3	QPSK	8	4	23.43	0-1	1
	714.5	23165	3	QPSK	8	7	23.38	0-1	1
	714.5	23165	3	QPSK	15	0	23.32	0-1	1
	714.5	23165	3	16-QAM	1	0	23.50	0-1	1
	714.5	23165	3	16-QAM	1	7	23.50	0-1	1
	714.5	23165	3	16-QAM	1	14	23.44	0-1	1
	714.5	23165	3	16-QAM	8	0	22.27	0-2	2
	714.5	23165	3	16-QAM	8	4	22.37	0-2	2
714.5	23165	3	16-QAM	8	7	22.37	0-2	2	
714.5	23165	3	16-QAM	15	0	22.30	0-2	2	

FCC ID: ZNFV930	 PCTEST <small>ENGINEERING LABORATORY, INC.</small>	SAR EVALUATION REPORT		Reviewed by: Quality Manager
Document S/N: OY1506161253-R2.ZNF	Test Dates: 06/17/15 - 06/23/15	DUT Type: Portable Tablet		Page 21 of 88

**Table 8-6
LTE Band 12 Conducted Powers – 1.4 MHz Bandwidth
Maximum Power**

	Frequency [MHz]	Channel	Bandwidth [MHz]	Modulation	RB Size	RB Offset	Conducted Power [dBm]	MPR Allowed per 3GPP [dB]	MPR [dB]
Low	699.7	23017	1.4	QPSK	1	0	24.44	0	0
	699.7	23017	1.4	QPSK	1	2	24.48	0	0
	699.7	23017	1.4	QPSK	1	5	24.50	0	0
	699.7	23017	1.4	QPSK	3	0	24.42	0	0
	699.7	23017	1.4	QPSK	3	2	24.46	0	0
	699.7	23017	1.4	QPSK	3	3	24.50	0	0
	699.7	23017	1.4	QPSK	6	0	23.39	0-1	1
	699.7	23017	1.4	16-QAM	1	0	23.32	0-1	1
	699.7	23017	1.4	16-QAM	1	2	23.27	0-1	1
	699.7	23017	1.4	16-QAM	1	5	23.37	0-1	1
	699.7	23017	1.4	16-QAM	3	0	23.41	0-1	1
	699.7	23017	1.4	16-QAM	3	2	23.34	0-1	1
	699.7	23017	1.4	16-QAM	3	3	23.43	0-1	1
699.7	23017	1.4	16-QAM	6	0	22.30	0-2	2	
Mid	707.5	23095	1.4	QPSK	1	0	24.47	0	0
	707.5	23095	1.4	QPSK	1	2	24.36	0	0
	707.5	23095	1.4	QPSK	1	5	24.15	0	0
	707.5	23095	1.4	QPSK	3	0	24.39	0	0
	707.5	23095	1.4	QPSK	3	2	24.31	0	0
	707.5	23095	1.4	QPSK	3	3	24.10	0	0
	707.5	23095	1.4	QPSK	6	0	23.14	0-1	1
	707.5	23095	1.4	16-QAM	1	0	23.35	0-1	1
	707.5	23095	1.4	16-QAM	1	2	23.24	0-1	1
	707.5	23095	1.4	16-QAM	1	5	22.97	0-1	1
	707.5	23095	1.4	16-QAM	3	0	23.38	0-1	1
	707.5	23095	1.4	16-QAM	3	2	23.16	0-1	1
	707.5	23095	1.4	16-QAM	3	3	23.00	0-1	1
707.5	23095	1.4	16-QAM	6	0	22.31	0-2	2	
High	715.3	23173	1.4	QPSK	1	0	24.50	0	0
	715.3	23173	1.4	QPSK	1	2	24.44	0	0
	715.3	23173	1.4	QPSK	1	5	24.42	0	0
	715.3	23173	1.4	QPSK	3	0	24.48	0	0
	715.3	23173	1.4	QPSK	3	2	24.35	0	0
	715.3	23173	1.4	QPSK	3	3	24.34	0	0
	715.3	23173	1.4	QPSK	6	0	23.43	0-1	1
	715.3	23173	1.4	16-QAM	1	0	23.34	0-1	1
	715.3	23173	1.4	16-QAM	1	2	23.31	0-1	1
	715.3	23173	1.4	16-QAM	1	5	23.27	0-1	1
	715.3	23173	1.4	16-QAM	3	0	23.47	0-1	1
	715.3	23173	1.4	16-QAM	3	2	23.25	0-1	1
	715.3	23173	1.4	16-QAM	3	3	23.26	0-1	1
715.3	23173	1.4	16-QAM	6	0	22.32	0-2	2	



FCC ID: ZNFV930	 PCTEST <small>ENGINEERING LABORATORY, INC.</small>	SAR EVALUATION REPORT		Reviewed by: Quality Manager
Document S/N: OY1506161253-R2.ZNF	Test Dates: 06/17/15 - 06/23/15	DUT Type: Portable Tablet		Page 22 of 88

Table 8-7
LTE Band 12 Conducted Powers - 10 MHz Bandwidth
Reduced Power – Body at 0.0 cm

	Frequency [MHz]	Channel	Bandwidth [MHz]	Modulation	RB Size	RB Offset	Conducted Power [dBm]	MPR Allowed per 3GPP [dB]	MPR [dB]
Mid	707.5	23095	10	QPSK	1	0	18.23	0	0
	707.5	23095	10	QPSK	1	25	18.22	0	0
	707.5	23095	10	QPSK	1	49	18.18	0	0
	707.5	23095	10	QPSK	25	0	18.14	0-1	0
	707.5	23095	10	QPSK	25	12	18.21	0-1	0
	707.5	23095	10	QPSK	25	25	18.28	0-1	0
	707.5	23095	10	QPSK	50	0	18.18	0-1	0
	707.5	23095	10	16QAM	1	0	18.39	0-1	0
	707.5	23095	10	16QAM	1	25	18.42	0-1	0
	707.5	23095	10	16QAM	1	49	18.38	0-1	0
	707.5	23095	10	16QAM	25	0	18.28	0-2	0
	707.5	23095	10	16QAM	25	12	18.27	0-2	0
	707.5	23095	10	16QAM	25	25	18.28	0-2	0
707.5	23095	10	16QAM	50	0	18.26	0-2	0	

Note: LTE Band 12 at 10 MHz bandwidth does not support three non-overlapping channels. Per KDB Publication 941225 D05v02, when a device supports overlapping channel assignment in a channel bandwidth configuration, the middle channel of the group of overlapping channels should be selected for testing.



FCC ID: ZNFV930	 PCTEST <small>ENGINEERING LABORATORY, INC.</small>	SAR EVALUATION REPORT		Reviewed by: Quality Manager
Document S/N: OY1506161253-R2.ZNF	Test Dates: 06/17/15 - 06/23/15	DUT Type: Portable Tablet		Page 23 of 88

Table 8-8
LTE Band 12 Conducted Powers - 5 MHz Bandwidth
Reduced Power – Body at 0.0 cm

	Frequency [MHz]	Channel	Bandwidth [MHz]	Modulation	RB Size	RB Offset	Conducted Power [dBm]	MPR Allowed per 3GPP [dB]	MPR [dB]
Low	701.5	23035	5	QPSK	1	0	18.00	0	0
	701.5	23035	5	QPSK	1	12	17.99	0	0
	701.5	23035	5	QPSK	1	24	18.03	0	0
	701.5	23035	5	QPSK	12	0	18.12	0-1	0
	701.5	23035	5	QPSK	12	6	18.17	0-1	0
	701.5	23035	5	QPSK	12	13	18.18	0-1	0
	701.5	23035	5	QPSK	25	0	18.14	0-1	0
	701.5	23035	5	16-QAM	1	0	18.05	0-1	0
	701.5	23035	5	16-QAM	1	12	18.07	0-1	0
	701.5	23035	5	16-QAM	1	24	18.13	0-1	0
	701.5	23035	5	16-QAM	12	0	18.17	0-2	0
	701.5	23035	5	16-QAM	12	6	18.21	0-2	0
701.5	23035	5	16-QAM	12	13	18.22	0-2	0	
701.5	23035	5	16-QAM	25	0	18.25	0-2	0	
Mid	707.5	23095	5	QPSK	1	0	18.18	0	0
	707.5	23095	5	QPSK	1	12	18.10	0	0
	707.5	23095	5	QPSK	1	24	18.05	0	0
	707.5	23095	5	QPSK	12	0	18.27	0-1	0
	707.5	23095	5	QPSK	12	6	18.24	0-1	0
	707.5	23095	5	QPSK	12	13	18.18	0-1	0
	707.5	23095	5	QPSK	25	0	18.15	0-1	0
	707.5	23095	5	16-QAM	1	0	18.50	0-1	0
	707.5	23095	5	16-QAM	1	12	18.43	0-1	0
	707.5	23095	5	16-QAM	1	24	18.49	0-1	0
	707.5	23095	5	16-QAM	12	0	18.20	0-2	0
	707.5	23095	5	16-QAM	12	6	18.16	0-2	0
	707.5	23095	5	16-QAM	12	13	18.09	0-2	0
	707.5	23095	5	16-QAM	25	0	18.16	0-2	0
High	713.5	23155	5	QPSK	1	0	18.17	0	0
	713.5	23155	5	QPSK	1	12	18.20	0	0
	713.5	23155	5	QPSK	1	24	18.26	0	0
	713.5	23155	5	QPSK	12	0	18.20	0-1	0
	713.5	23155	5	QPSK	12	6	18.18	0-1	0
	713.5	23155	5	QPSK	12	13	18.21	0-1	0
	713.5	23155	5	QPSK	25	0	18.18	0-1	0
	713.5	23155	5	16-QAM	1	0	18.32	0-1	0
	713.5	23155	5	16-QAM	1	12	18.32	0-1	0
	713.5	23155	5	16-QAM	1	24	18.35	0-1	0
	713.5	23155	5	16-QAM	12	0	18.14	0-2	0
	713.5	23155	5	16-QAM	12	6	18.19	0-2	0
713.5	23155	5	16-QAM	12	13	18.21	0-2	0	
713.5	23155	5	16-QAM	25	0	18.27	0-2	0	



FCC ID: ZNFV930	 PCTEST <small>ENGINEERING LABORATORY, INC.</small>	SAR EVALUATION REPORT		Reviewed by: Quality Manager
Document S/N: OY1506161253-R2.ZNF	Test Dates: 06/17/15 - 06/23/15	DUT Type: Portable Tablet		Page 24 of 88

Table 8-9
LTE Band 12 Conducted Powers - 3 MHz Bandwidth
Reduced Power – Body at 0.0 cm

	Frequency [MHz]	Channel	Bandwidth [MHz]	Modulation	RB Size	RB Offset	Conducted Power [dBm]	MPR Allowed per 3GPP [dB]	MPR [dB]
Low	700.5	23025	3	QPSK	1	0	18.08	0	0
	700.5	23025	3	QPSK	1	7	18.07	0	0
	700.5	23025	3	QPSK	1	14	18.02	0	0
	700.5	23025	3	QPSK	8	0	18.16	0-1	0
	700.5	23025	3	QPSK	8	4	18.14	0-1	0
	700.5	23025	3	QPSK	8	7	18.16	0-1	0
	700.5	23025	3	QPSK	15	0	18.16	0-1	0
	700.5	23025	3	16-QAM	1	0	18.50	0-1	0
	700.5	23025	3	16-QAM	1	7	18.50	0-1	0
	700.5	23025	3	16-QAM	1	14	18.43	0-1	0
	700.5	23025	3	16-QAM	8	0	18.08	0-2	0
	700.5	23025	3	16-QAM	8	4	18.11	0-2	0
700.5	23025	3	16-QAM	8	7	18.09	0-2	0	
700.5	23025	3	16-QAM	15	0	18.16	0-2	0	
Mid	707.5	23095	3	QPSK	1	0	18.08	0	0
	707.5	23095	3	QPSK	1	7	18.21	0	0
	707.5	23095	3	QPSK	1	14	18.33	0	0
	707.5	23095	3	QPSK	8	0	18.14	0-1	0
	707.5	23095	3	QPSK	8	4	18.10	0-1	0
	707.5	23095	3	QPSK	8	7	18.20	0-1	0
	707.5	23095	3	QPSK	15	0	18.23	0-1	0
	707.5	23095	3	16-QAM	1	0	18.28	0-1	0
	707.5	23095	3	16-QAM	1	7	18.22	0-1	0
	707.5	23095	3	16-QAM	1	14	18.33	0-1	0
	707.5	23095	3	16-QAM	8	0	18.11	0-2	0
	707.5	23095	3	16-QAM	8	4	18.10	0-2	0
	707.5	23095	3	16-QAM	8	7	18.16	0-2	0
	707.5	23095	3	16-QAM	15	0	18.23	0-2	0
High	714.5	23165	3	QPSK	1	0	18.13	0	0
	714.5	23165	3	QPSK	1	7	18.12	0	0
	714.5	23165	3	QPSK	1	14	18.09	0	0
	714.5	23165	3	QPSK	8	0	18.16	0-1	0
	714.5	23165	3	QPSK	8	4	18.19	0-1	0
	714.5	23165	3	QPSK	8	7	18.20	0-1	0
	714.5	23165	3	QPSK	15	0	18.21	0-1	0
	714.5	23165	3	16-QAM	1	0	18.12	0-1	0
	714.5	23165	3	16-QAM	1	7	18.11	0-1	0
	714.5	23165	3	16-QAM	1	14	18.11	0-1	0
	714.5	23165	3	16-QAM	8	0	18.16	0-2	0
	714.5	23165	3	16-QAM	8	4	18.19	0-2	0
714.5	23165	3	16-QAM	8	7	18.20	0-2	0	
714.5	23165	3	16-QAM	15	0	18.26	0-2	0	





FCC ID: ZNFV930	 PCTEST <small>ENGINEERING LABORATORY, INC.</small>	SAR EVALUATION REPORT		Reviewed by: Quality Manager
Document S/N: OY1506161253-R2.ZNF	Test Dates: 06/17/15 - 06/23/15	DUT Type: Portable Tablet		Page 25 of 88

Table 8-10
LTE Band 12 Conducted Powers – 1.4 MHz Bandwidth
Reduced Power – Body at 0.0 cm

	Frequency [MHz]	Channel	Bandwidth [MHz]	Modulation	RB Size	RB Offset	Conducted Power [dBm]	MPR Allowed per 3GPP [dB]	MPR [dB]
Low	699.7	23017	1.4	QPSK	1	0	18.34	0	0
	699.7	23017	1.4	QPSK	1	2	18.28	0	0
	699.7	23017	1.4	QPSK	1	5	18.38	0	0
	699.7	23017	1.4	QPSK	3	0	18.16	0	0
	699.7	23017	1.4	QPSK	3	2	18.16	0	0
	699.7	23017	1.4	QPSK	3	3	18.15	0	0
	699.7	23017	1.4	QPSK	6	0	18.24	0-1	0
	699.7	23017	1.4	16-QAM	1	0	18.00	0-1	0
	699.7	23017	1.4	16-QAM	1	2	17.95	0-1	0
	699.7	23017	1.4	16-QAM	1	5	18.04	0-1	0
	699.7	23017	1.4	16-QAM	3	0	18.16	0-1	0
	699.7	23017	1.4	16-QAM	3	2	18.17	0-1	0
	699.7	23017	1.4	16-QAM	3	3	18.21	0-1	0
699.7	23017	1.4	16-QAM	6	0	18.35	0-2	0	
Mid	707.5	23095	1.4	QPSK	1	0	18.15	0	0
	707.5	23095	1.4	QPSK	1	2	18.13	0	0
	707.5	23095	1.4	QPSK	1	5	18.20	0	0
	707.5	23095	1.4	QPSK	3	0	18.12	0	0
	707.5	23095	1.4	QPSK	3	2	18.14	0	0
	707.5	23095	1.4	QPSK	3	3	18.25	0	0
	707.5	23095	1.4	QPSK	6	0	18.21	0-1	0
	707.5	23095	1.4	16-QAM	1	0	18.26	0-1	0
	707.5	23095	1.4	16-QAM	1	2	18.23	0-1	0
	707.5	23095	1.4	16-QAM	1	5	18.32	0-1	0
	707.5	23095	1.4	16-QAM	3	0	18.18	0-1	0
	707.5	23095	1.4	16-QAM	3	2	18.13	0-1	0
	707.5	23095	1.4	16-QAM	3	3	18.21	0-1	0
707.5	23095	1.4	16-QAM	6	0	18.21	0-2	0	
High	715.3	23173	1.4	QPSK	1	0	18.19	0	0
	715.3	23173	1.4	QPSK	1	2	18.12	0	0
	715.3	23173	1.4	QPSK	1	5	18.12	0	0
	715.3	23173	1.4	QPSK	3	0	18.19	0	0
	715.3	23173	1.4	QPSK	3	2	18.20	0	0
	715.3	23173	1.4	QPSK	3	3	18.19	0	0
	715.3	23173	1.4	QPSK	6	0	18.14	0-1	0
	715.3	23173	1.4	16-QAM	1	0	18.10	0-1	0
	715.3	23173	1.4	16-QAM	1	2	18.13	0-1	0
	715.3	23173	1.4	16-QAM	1	5	18.17	0-1	0
	715.3	23173	1.4	16-QAM	3	0	18.23	0-1	0
	715.3	23173	1.4	16-QAM	3	2	18.22	0-1	0
	715.3	23173	1.4	16-QAM	3	3	18.21	0-1	0
715.3	23173	1.4	16-QAM	6	0	18.13	0-2	0	

FCC ID: ZNFV930	 PCTEST <small>ENGINEERING LABORATORY, INC.</small>	SAR EVALUATION REPORT		Reviewed by: Quality Manager
Document S/N: OY1506161253-R2.ZNF	Test Dates: 06/17/15 - 06/23/15	DUT Type: Portable Tablet		Page 26 of 88

8.2.2

LTE Band 5

Table 8-11
LTE Band 5 Conducted Powers - 10 MHz Bandwidth
Maximum Power

	Frequency [MHz]	Channel	Bandwidth [MHz]	Modulation	RB Size	RB Offset	Conducted Power [dBm]	MPR Allowed per 3GPP [dB]	MPR [dB]
Mid	836.5	20525	10	QPSK	1	0	24.45	0	0
	836.5	20525	10	QPSK	1	25	24.46	0	0
	836.5	20525	10	QPSK	1	49	24.50	0	0
	836.5	20525	10	QPSK	25	0	23.25	0-1	1
	836.5	20525	10	QPSK	25	12	23.37	0-1	1
	836.5	20525	10	QPSK	25	25	23.30	0-1	1
	836.5	20525	10	QPSK	50	0	23.31	0-1	1
	836.5	20525	10	16QAM	1	0	23.42	0-1	1
	836.5	20525	10	16QAM	1	25	23.47	0-1	1
	836.5	20525	10	16QAM	1	49	23.50	0-1	1
	836.5	20525	10	16QAM	25	0	22.17	0-2	2
	836.5	20525	10	16QAM	25	12	22.30	0-2	2
	836.5	20525	10	16QAM	25	25	22.21	0-2	2
	836.5	20525	10	16QAM	50	0	22.22	0-2	2

Note: LTE Band 5 at 10 MHz bandwidth does not support three non-overlapping channels. Per KDB Publication 941225 D05v02, when a device supports overlapping channel assignment in a channel bandwidth configuration, the middle channel of the group of overlapping channels should be selected for testing.



FCC ID: ZNFV930	 PCTEST ENGINEERING LABORATORY, INC.	SAR EVALUATION REPORT	 LG	Reviewed by: Quality Manager
Document S/N: OY1506161253-R2.ZNF	Test Dates: 06/17/15 - 06/23/15	DUT Type: Portable Tablet		Page 27 of 88

Table 8-12
LTE Band 5 Conducted Powers - 5 MHz Bandwidth
Maximum Power

	Frequency [MHz]	Channel	Bandwidth [MHz]	Modulation	RB Size	RB Offset	Conducted Power [dBm]	MPR Allowed per 3GPP [dB]	MPR [dB]
Low	826.5	20425	5	QPSK	1	0	24.24	0	0
	826.5	20425	5	QPSK	1	12	24.18	0	0
	826.5	20425	5	QPSK	1	24	24.30	0	0
	826.5	20425	5	QPSK	12	0	23.10	0-1	1
	826.5	20425	5	QPSK	12	6	23.14	0-1	1
	826.5	20425	5	QPSK	12	13	23.00	0-1	1
	826.5	20425	5	QPSK	25	0	23.20	0-1	1
	826.5	20425	5	16-QAM	1	0	22.88	0-1	1
	826.5	20425	5	16-QAM	1	12	22.88	0-1	1
	826.5	20425	5	16-QAM	1	24	22.90	0-1	1
	826.5	20425	5	16-QAM	12	0	21.95	0-2	2
	826.5	20425	5	16-QAM	12	6	21.92	0-2	2
	826.5	20425	5	16-QAM	12	13	21.91	0-2	2
826.5	20425	5	16-QAM	25	0	22.06	0-2	2	
Mid	836.5	20525	5	QPSK	1	0	24.30	0	0
	836.5	20525	5	QPSK	1	12	24.33	0	0
	836.5	20525	5	QPSK	1	24	24.37	0	0
	836.5	20525	5	QPSK	12	0	23.22	0-1	1
	836.5	20525	5	QPSK	12	6	23.22	0-1	1
	836.5	20525	5	QPSK	12	13	23.25	0-1	1
	836.5	20525	5	QPSK	25	0	23.22	0-1	1
	836.5	20525	5	16-QAM	1	0	22.96	0-1	1
	836.5	20525	5	16-QAM	1	12	22.92	0-1	1
	836.5	20525	5	16-QAM	1	24	23.03	0-1	1
	836.5	20525	5	16-QAM	12	0	22.06	0-2	2
	836.5	20525	5	16-QAM	12	6	22.06	0-2	2
	836.5	20525	5	16-QAM	12	13	22.06	0-2	2
836.5	20525	5	16-QAM	25	0	22.16	0-2	2	
High	846.5	20625	5	QPSK	1	0	24.34	0	0
	846.5	20625	5	QPSK	1	12	24.30	0	0
	846.5	20625	5	QPSK	1	24	24.18	0	0
	846.5	20625	5	QPSK	12	0	23.09	0-1	1
	846.5	20625	5	QPSK	12	6	23.20	0-1	1
	846.5	20625	5	QPSK	12	13	23.11	0-1	1
	846.5	20625	5	QPSK	25	0	23.07	0-1	1
	846.5	20625	5	16-QAM	1	0	22.86	0-1	1
	846.5	20625	5	16-QAM	1	12	22.98	0-1	1
	846.5	20625	5	16-QAM	1	24	22.88	0-1	1
	846.5	20625	5	16-QAM	12	0	21.95	0-2	2
	846.5	20625	5	16-QAM	12	6	22.00	0-2	2
	846.5	20625	5	16-QAM	12	13	21.91	0-2	2
846.5	20625	5	16-QAM	25	0	22.00	0-2	2	



FCC ID: ZNFV930	 PCTEST <small>ENGINEERING LABORATORY, INC.</small>	SAR EVALUATION REPORT		Reviewed by: Quality Manager
Document S/N: OY1506161253-R2.ZNF	Test Dates: 06/17/15 - 06/23/15	DUT Type: Portable Tablet		Page 28 of 88

Table 8-13
LTE Band 5 Conducted Powers - 3 MHz Bandwidth
Maximum Power

	Frequency [MHz]	Channel	Bandwidth [MHz]	Modulation	RB Size	RB Offset	Conducted Power [dBm]	MPR Allowed per 3GPP [dB]	MPR [dB]
Low	825.5	20415	3	QPSK	1	0	24.36	0	0
	825.5	20415	3	QPSK	1	7	24.40	0	0
	825.5	20415	3	QPSK	1	14	24.37	0	0
	825.5	20415	3	QPSK	8	0	23.13	0-1	1
	825.5	20415	3	QPSK	8	4	23.13	0-1	1
	825.5	20415	3	QPSK	8	7	23.15	0-1	1
	825.5	20415	3	QPSK	15	0	23.12	0-1	1
	825.5	20415	3	16-QAM	1	0	23.41	0-1	1
	825.5	20415	3	16-QAM	1	7	23.40	0-1	1
	825.5	20415	3	16-QAM	1	14	23.24	0-1	1
	825.5	20415	3	16-QAM	8	0	22.05	0-2	2
	825.5	20415	3	16-QAM	8	4	22.01	0-2	2
825.5	20415	3	16-QAM	8	7	22.04	0-2	2	
825.5	20415	3	16-QAM	15	0	22.03	0-2	2	
Mid	836.5	20525	3	QPSK	1	0	24.47	0	0
	836.5	20525	3	QPSK	1	7	24.48	0	0
	836.5	20525	3	QPSK	1	14	24.49	0	0
	836.5	20525	3	QPSK	8	0	23.23	0-1	1
	836.5	20525	3	QPSK	8	4	23.22	0-1	1
	836.5	20525	3	QPSK	8	7	23.24	0-1	1
	836.5	20525	3	QPSK	15	0	23.23	0-1	1
	836.5	20525	3	16-QAM	1	0	23.44	0-1	1
	836.5	20525	3	16-QAM	1	7	23.41	0-1	1
	836.5	20525	3	16-QAM	1	14	23.30	0-1	1
	836.5	20525	3	16-QAM	8	0	22.16	0-2	2
	836.5	20525	3	16-QAM	8	4	22.13	0-2	2
836.5	20525	3	16-QAM	8	7	22.12	0-2	2	
836.5	20525	3	16-QAM	15	0	22.15	0-2	2	
High	847.5	20635	3	QPSK	1	0	24.50	0	0
	847.5	20635	3	QPSK	1	7	24.34	0	0
	847.5	20635	3	QPSK	1	14	24.33	0	0
	847.5	20635	3	QPSK	8	0	23.21	0-1	1
	847.5	20635	3	QPSK	8	4	23.09	0-1	1
	847.5	20635	3	QPSK	8	7	22.97	0-1	1
	847.5	20635	3	QPSK	15	0	23.10	0-1	1
	847.5	20635	3	16-QAM	1	0	23.33	0-1	1
	847.5	20635	3	16-QAM	1	7	23.27	0-1	1
	847.5	20635	3	16-QAM	1	14	23.46	0-1	1
	847.5	20635	3	16-QAM	8	0	22.11	0-2	2
	847.5	20635	3	16-QAM	8	4	22.01	0-2	2
847.5	20635	3	16-QAM	8	7	21.87	0-2	2	
847.5	20635	3	16-QAM	15	0	21.92	0-2	2	



FCC ID: ZNFV930	 PCTEST <small>ENGINEERING LABORATORY, INC.</small>	SAR EVALUATION REPORT		Reviewed by: Quality Manager
Document S/N: OY1506161253-R2.ZNF	Test Dates: 06/17/15 - 06/23/15	DUT Type: Portable Tablet		Page 29 of 88

Table 8-14
LTE Band 5 Conducted Powers – 1.4 MHz Bandwidth
Maximum Power

	Frequency [MHz]	Channel	Bandwidth [MHz]	Modulation	RB Size	RB Offset	Conducted Power [dBm]	MPR Allowed per 3GPP [dB]	MPR [dB]
Low	824.7	20407	1.4	QPSK	1	0	24.48	0	0
	824.7	20407	1.4	QPSK	1	2	24.31	0	0
	824.7	20407	1.4	QPSK	1	5	24.34	0	0
	824.7	20407	1.4	QPSK	3	0	24.31	0	0
	824.7	20407	1.4	QPSK	3	2	24.31	0	0
	824.7	20407	1.4	QPSK	3	3	24.37	0	0
	824.7	20407	1.4	QPSK	6	0	23.18	0-1	1
	824.7	20407	1.4	16-QAM	1	0	23.19	0-1	1
	824.7	20407	1.4	16-QAM	1	2	23.15	0-1	1
	824.7	20407	1.4	16-QAM	1	5	23.29	0-1	1
	824.7	20407	1.4	16-QAM	3	0	23.06	0-1	1
	824.7	20407	1.4	16-QAM	3	2	23.06	0-1	1
	824.7	20407	1.4	16-QAM	3	3	23.13	0-1	1
824.7	20407	1.4	16-QAM	6	0	22.26	0-2	2	
Mid	836.5	20525	1.4	QPSK	1	0	24.50	0	0
	836.5	20525	1.4	QPSK	1	2	24.41	0	0
	836.5	20525	1.4	QPSK	1	5	24.49	0	0
	836.5	20525	1.4	QPSK	3	0	24.37	0	0
	836.5	20525	1.4	QPSK	3	2	24.42	0	0
	836.5	20525	1.4	QPSK	3	3	24.39	0	0
	836.5	20525	1.4	QPSK	6	0	23.29	0-1	1
	836.5	20525	1.4	16-QAM	1	0	23.06	0-1	1
	836.5	20525	1.4	16-QAM	1	2	23.26	0-1	1
	836.5	20525	1.4	16-QAM	1	5	23.19	0-1	1
	836.5	20525	1.4	16-QAM	3	0	23.25	0-1	1
	836.5	20525	1.4	16-QAM	3	2	23.25	0-1	1
	836.5	20525	1.4	16-QAM	3	3	23.19	0-1	1
836.5	20525	1.4	16-QAM	6	0	22.25	0-2	2	
High	848.3	20643	1.4	QPSK	1	0	24.29	0	0
	848.3	20643	1.4	QPSK	1	2	24.30	0	0
	848.3	20643	1.4	QPSK	1	5	24.25	0	0
	848.3	20643	1.4	QPSK	3	0	24.18	0	0
	848.3	20643	1.4	QPSK	3	2	24.15	0	0
	848.3	20643	1.4	QPSK	3	3	24.20	0	0
	848.3	20643	1.4	QPSK	6	0	23.02	0-1	1
	848.3	20643	1.4	16-QAM	1	0	22.99	0-1	1
	848.3	20643	1.4	16-QAM	1	2	22.98	0-1	1
	848.3	20643	1.4	16-QAM	1	5	22.97	0-1	1
	848.3	20643	1.4	16-QAM	3	0	22.94	0-1	1
	848.3	20643	1.4	16-QAM	3	2	22.98	0-1	1
	848.3	20643	1.4	16-QAM	3	3	22.97	0-1	1
848.3	20643	1.4	16-QAM	6	0	22.06	0-2	2	



FCC ID: ZNFV930	 PCTEST <small>ENGINEERING LABORATORY, INC.</small>	SAR EVALUATION REPORT		Reviewed by: Quality Manager
Document S/N: OY1506161253-R2.ZNF	Test Dates: 06/17/15 - 06/23/15	DUT Type: Portable Tablet		Page 30 of 88

Table 8-15
LTE Band 5 Conducted Powers - 10 MHz Bandwidth
Reduced Power – Body at 0.0 cm

	Frequency [MHz]	Channel	Bandwidth [MHz]	Modulation	RB Size	RB Offset	Conducted Power [dBm]	MPR Allowed per 3GPP [dB]	MPR [dB]
Mid	836.5	20525	10	QPSK	1	0	18.25	0	0
	836.5	20525	10	QPSK	1	25	18.23	0	0
	836.5	20525	10	QPSK	1	49	18.38	0	0
	836.5	20525	10	QPSK	25	0	18.13	0-1	0
	836.5	20525	10	QPSK	25	12	18.22	0-1	0
	836.5	20525	10	QPSK	25	25	18.27	0-1	0
	836.5	20525	10	QPSK	50	0	18.26	0-1	0
	836.5	20525	10	16QAM	1	0	18.43	0-1	0
	836.5	20525	10	16QAM	1	25	18.38	0-1	0
	836.5	20525	10	16QAM	1	49	18.46	0-1	0
	836.5	20525	10	16QAM	25	0	18.18	0-2	0
	836.5	20525	10	16QAM	25	12	18.27	0-2	0
	836.5	20525	10	16QAM	25	25	18.30	0-2	0
	836.5	20525	10	16QAM	50	0	18.23	0-2	0

Note: LTE Band 5 at 10 MHz bandwidth does not support three non-overlapping channels. Per KDB Publication 941225 D05v02, when a device supports overlapping channel assignment in a channel bandwidth configuration, the middle channel of the group of overlapping channels should be selected for testing.



FCC ID: ZNFV930	 PCTEST <small>ENGINEERING LABORATORY, INC.</small>	SAR EVALUATION REPORT		Reviewed by: Quality Manager
Document S/N: OY1506161253-R2.ZNF	Test Dates: 06/17/15 - 06/23/15	DUT Type: Portable Tablet		Page 31 of 88

Table 8-16
LTE Band 5 Conducted Powers - 5 MHz Bandwidth
Reduced Power – Body at 0.0 cm

	Frequency [MHz]	Channel	Bandwidth [MHz]	Modulation	RB Size	RB Offset	Conducted Power [dBm]	MPR Allowed per 3GPP [dB]	MPR [dB]
Low	826.5	20425	5	QPSK	1	0	18.26	0	0
	826.5	20425	5	QPSK	1	12	18.34	0	0
	826.5	20425	5	QPSK	1	24	18.33	0	0
	826.5	20425	5	QPSK	12	0	18.27	0-1	0
	826.5	20425	5	QPSK	12	6	18.28	0-1	0
	826.5	20425	5	QPSK	12	13	18.30	0-1	0
	826.5	20425	5	QPSK	25	0	18.28	0-1	0
	826.5	20425	5	16-QAM	1	0	18.44	0-1	0
	826.5	20425	5	16-QAM	1	12	18.42	0-1	0
	826.5	20425	5	16-QAM	1	24	18.41	0-1	0
	826.5	20425	5	16-QAM	12	0	18.27	0-2	0
	826.5	20425	5	16-QAM	12	6	18.20	0-2	0
826.5	20425	5	16-QAM	12	13	18.18	0-2	0	
826.5	20425	5	16-QAM	25	0	18.31	0-2	0	
Mid	836.5	20525	5	QPSK	1	0	18.03	0	0
	836.5	20525	5	QPSK	1	12	18.17	0	0
	836.5	20525	5	QPSK	1	24	18.22	0	0
	836.5	20525	5	QPSK	12	0	18.26	0-1	0
	836.5	20525	5	QPSK	12	6	18.35	0-1	0
	836.5	20525	5	QPSK	12	13	18.31	0-1	0
	836.5	20525	5	QPSK	25	0	18.29	0-1	0
	836.5	20525	5	16-QAM	1	0	18.12	0-1	0
	836.5	20525	5	16-QAM	1	12	18.19	0-1	0
	836.5	20525	5	16-QAM	1	24	18.28	0-1	0
	836.5	20525	5	16-QAM	12	0	18.32	0-2	0
	836.5	20525	5	16-QAM	12	6	18.28	0-2	0
836.5	20525	5	16-QAM	12	13	18.37	0-2	0	
836.5	20525	5	16-QAM	25	0	18.33	0-2	0	
High	846.5	20625	5	QPSK	1	0	18.34	0	0
	846.5	20625	5	QPSK	1	12	18.40	0	0
	846.5	20625	5	QPSK	1	24	18.33	0	0
	846.5	20625	5	QPSK	12	0	18.24	0-1	0
	846.5	20625	5	QPSK	12	6	18.34	0-1	0
	846.5	20625	5	QPSK	12	13	18.25	0-1	0
	846.5	20625	5	QPSK	25	0	18.29	0-1	0
	846.5	20625	5	16-QAM	1	0	18.44	0-1	0
	846.5	20625	5	16-QAM	1	12	18.41	0-1	0
	846.5	20625	5	16-QAM	1	24	18.33	0-1	0
	846.5	20625	5	16-QAM	12	0	18.27	0-2	0
	846.5	20625	5	16-QAM	12	6	18.36	0-2	0
846.5	20625	5	16-QAM	12	13	18.28	0-2	0	
846.5	20625	5	16-QAM	25	0	18.25	0-2	0	



FCC ID: ZNFV930	 PCTEST <small>ENGINEERING LABORATORY, INC.</small>	SAR EVALUATION REPORT		Reviewed by: Quality Manager
Document S/N: OY1506161253-R2.ZNF	Test Dates: 06/17/15 - 06/23/15	DUT Type: Portable Tablet		Page 32 of 88

Table 8-17
LTE Band 5 Conducted Powers - 3 MHz Bandwidth
Reduced Power – Body at 0.0 cm

	Frequency [MHz]	Channel	Bandwidth [MHz]	Modulation	RB Size	RB Offset	Conducted Power [dBm]	MPR Allowed per 3GPP [dB]	MPR [dB]
Low	825.5	20415	3	QPSK	1	0	18.33	0	0
	825.5	20415	3	QPSK	1	7	18.26	0	0
	825.5	20415	3	QPSK	1	14	18.31	0	0
	825.5	20415	3	QPSK	8	0	18.27	0-1	0
	825.5	20415	3	QPSK	8	4	18.28	0-1	0
	825.5	20415	3	QPSK	8	7	18.24	0-1	0
	825.5	20415	3	QPSK	15	0	18.28	0-1	0
	825.5	20415	3	16-QAM	1	0	18.36	0-1	0
	825.5	20415	3	16-QAM	1	7	18.31	0-1	0
	825.5	20415	3	16-QAM	1	14	18.32	0-1	0
	825.5	20415	3	16-QAM	8	0	18.21	0-2	0
	825.5	20415	3	16-QAM	8	4	18.21	0-2	0
825.5	20415	3	16-QAM	8	7	18.19	0-2	0	
825.5	20415	3	16-QAM	15	0	18.27	0-2	0	
Mid	836.5	20525	3	QPSK	1	0	18.22	0	0
	836.5	20525	3	QPSK	1	7	18.19	0	0
	836.5	20525	3	QPSK	1	14	18.22	0	0
	836.5	20525	3	QPSK	8	0	18.28	0-1	0
	836.5	20525	3	QPSK	8	4	18.28	0-1	0
	836.5	20525	3	QPSK	8	7	18.28	0-1	0
	836.5	20525	3	QPSK	15	0	18.30	0-1	0
	836.5	20525	3	16-QAM	1	0	18.48	0-1	0
	836.5	20525	3	16-QAM	1	7	18.28	0-1	0
	836.5	20525	3	16-QAM	1	14	18.45	0-1	0
	836.5	20525	3	16-QAM	8	0	18.27	0-2	0
	836.5	20525	3	16-QAM	8	4	18.21	0-2	0
836.5	20525	3	16-QAM	8	7	18.19	0-2	0	
836.5	20525	3	16-QAM	15	0	18.32	0-2	0	
High	847.5	20635	3	QPSK	1	0	18.34	0	0
	847.5	20635	3	QPSK	1	7	18.19	0	0
	847.5	20635	3	QPSK	1	14	18.39	0	0
	847.5	20635	3	QPSK	8	0	18.41	0-1	0
	847.5	20635	3	QPSK	8	4	18.20	0-1	0
	847.5	20635	3	QPSK	8	7	18.23	0-1	0
	847.5	20635	3	QPSK	15	0	18.26	0-1	0
	847.5	20635	3	16-QAM	1	0	18.45	0-1	0
	847.5	20635	3	16-QAM	1	7	18.32	0-1	0
	847.5	20635	3	16-QAM	1	14	18.49	0-1	0
	847.5	20635	3	16-QAM	8	0	18.32	0-2	0
	847.5	20635	3	16-QAM	8	4	18.24	0-2	0
847.5	20635	3	16-QAM	8	7	18.21	0-2	0	
847.5	20635	3	16-QAM	15	0	18.27	0-2	0	





FCC ID: ZNFV930	 PCTEST <small>ENGINEERING LABORATORY, INC.</small>	SAR EVALUATION REPORT		Reviewed by: Quality Manager
Document S/N: OY1506161253-R2.ZNF	Test Dates: 06/17/15 - 06/23/15	DUT Type: Portable Tablet		Page 33 of 88

Table 8-18
LTE Band 5 Conducted Powers – 1.4 MHz Bandwidth
Reduced Power – Body at 0.0 cm

	Frequency [MHz]	Channel	Bandwidth [MHz]	Modulation	RB Size	RB Offset	Conducted Power [dBm]	MPR Allowed per 3GPP [dB]	MPR [dB]
Low	824.7	20407	1.4	QPSK	1	0	18.27	0	0
	824.7	20407	1.4	QPSK	1	2	18.22	0	0
	824.7	20407	1.4	QPSK	1	5	18.27	0	0
	824.7	20407	1.4	QPSK	3	0	18.29	0	0
	824.7	20407	1.4	QPSK	3	2	18.24	0	0
	824.7	20407	1.4	QPSK	3	3	18.34	0	0
	824.7	20407	1.4	QPSK	6	0	18.37	0-1	0
	824.7	20407	1.4	16-QAM	1	0	18.36	0-1	0
	824.7	20407	1.4	16-QAM	1	2	18.36	0-1	0
	824.7	20407	1.4	16-QAM	1	5	18.43	0-1	0
	824.7	20407	1.4	16-QAM	3	0	18.23	0-1	0
	824.7	20407	1.4	16-QAM	3	2	18.21	0-1	0
	824.7	20407	1.4	16-QAM	3	3	18.21	0-1	0
824.7	20407	1.4	16-QAM	6	0	18.30	0-2	0	
Mid	836.5	20525	1.4	QPSK	1	0	18.25	0	0
	836.5	20525	1.4	QPSK	1	2	18.33	0	0
	836.5	20525	1.4	QPSK	1	5	18.29	0	0
	836.5	20525	1.4	QPSK	3	0	18.29	0	0
	836.5	20525	1.4	QPSK	3	2	18.38	0	0
	836.5	20525	1.4	QPSK	3	3	18.30	0	0
	836.5	20525	1.4	QPSK	6	0	18.33	0-1	0
	836.5	20525	1.4	16-QAM	1	0	18.28	0-1	0
	836.5	20525	1.4	16-QAM	1	2	18.31	0-1	0
	836.5	20525	1.4	16-QAM	1	5	18.29	0-1	0
	836.5	20525	1.4	16-QAM	3	0	18.38	0-1	0
	836.5	20525	1.4	16-QAM	3	2	18.41	0-1	0
	836.5	20525	1.4	16-QAM	3	3	18.41	0-1	0
836.5	20525	1.4	16-QAM	6	0	18.24	0-2	0	
High	848.3	20643	1.4	QPSK	1	0	18.23	0	0
	848.3	20643	1.4	QPSK	1	2	18.23	0	0
	848.3	20643	1.4	QPSK	1	5	18.20	0	0
	848.3	20643	1.4	QPSK	3	0	18.28	0	0
	848.3	20643	1.4	QPSK	3	2	18.32	0	0
	848.3	20643	1.4	QPSK	3	3	18.27	0	0
	848.3	20643	1.4	QPSK	6	0	18.26	0-1	0
	848.3	20643	1.4	16-QAM	1	0	18.20	0-1	0
	848.3	20643	1.4	16-QAM	1	2	18.28	0-1	0
	848.3	20643	1.4	16-QAM	1	5	18.29	0-1	0
	848.3	20643	1.4	16-QAM	3	0	18.29	0-1	0
	848.3	20643	1.4	16-QAM	3	2	18.33	0-1	0
	848.3	20643	1.4	16-QAM	3	3	18.34	0-1	0
848.3	20643	1.4	16-QAM	6	0	18.18	0-2	0	

FCC ID: ZNFV930	 PCTEST <small>ENGINEERING LABORATORY, INC.</small>	SAR EVALUATION REPORT		Reviewed by: Quality Manager
Document S/N: OY1506161253-R2.ZNF	Test Dates: 06/17/15 - 06/23/15	DUT Type: Portable Tablet		Page 34 of 88

8.2.3 LTE Band 4 (AWS)

Table 8-19
LTE Band 4 (AWS) Conducted Powers - 20 MHz Bandwidth
Maximum Power

	Frequency [MHz]	Channel	Bandwidth [MHz]	Modulation	RB Size	RB Offset	Conducted Power [dBm]	MPR Allowed per 3GPP [dB]	MPR [dB]
Mid	1732.5	20175	20	QPSK	1	0	25.00	0	0
	1732.5	20175	20	QPSK	1	50	24.96	0	0
	1732.5	20175	20	QPSK	1	99	24.95	0	0
	1732.5	20175	20	QPSK	50	0	23.86	0-1	1
	1732.5	20175	20	QPSK	50	25	23.76	0-1	1
	1732.5	20175	20	QPSK	50	50	23.58	0-1	1
	1732.5	20175	20	QPSK	100	0	23.75	0-1	1
	1732.5	20175	20	16QAM	1	0	23.88	0-1	1
	1732.5	20175	20	16QAM	1	50	23.93	0-1	1
	1732.5	20175	20	16QAM	1	99	23.91	0-1	1
	1732.5	20175	20	16QAM	50	0	22.59	0-2	2
	1732.5	20175	20	16QAM	50	25	22.52	0-2	2
	1732.5	20175	20	16QAM	50	50	22.51	0-2	2
1732.5	20175	20	16QAM	100	0	22.52	0-2	2	

Note: LTE Band 4 (AWS) at 20 MHz bandwidth does not support three non-overlapping channels. Per KDB Publication 941225 D05v02, when a device supports overlapping channel assignment in a channel bandwidth configuration, the middle channel of the group of overlapping channels should be selected for testing.



FCC ID: ZNFV930	 PCTEST <small>ENGINEERING LABORATORY, INC.</small>	SAR EVALUATION REPORT		Reviewed by: Quality Manager
Document S/N: OY1506161253-R2.ZNF	Test Dates: 06/17/15 - 06/23/15	DUT Type: Portable Tablet		Page 35 of 88

Table 8-20
LTE Band 4 (AWS) Conducted Powers - 15 MHz Bandwidth
Maximum Power

	Frequency [MHz]	Channel	Bandwidth [MHz]	Modulation	RB Size	RB Offset	Conducted Power [dBm]	MPR Allowed per 3GPP [dB]	MPR [dB]
Low	1717.5	20025	15	QPSK	1	0	24.82	0	0
	1717.5	20025	15	QPSK	1	36	24.86	0	0
	1717.5	20025	15	QPSK	1	74	24.92	0	0
	1717.5	20025	15	QPSK	36	0	23.83	0-1	1
	1717.5	20025	15	QPSK	36	18	23.89	0-1	1
	1717.5	20025	15	QPSK	36	37	23.87	0-1	1
	1717.5	20025	15	QPSK	75	0	23.90	0-1	1
	1717.5	20025	15	16QAM	1	0	23.99	0-1	1
	1717.5	20025	15	16QAM	1	36	23.96	0-1	1
	1717.5	20025	15	16QAM	1	74	24.00	0-1	1
	1717.5	20025	15	16QAM	36	0	22.61	0-2	2
	1717.5	20025	15	16QAM	36	18	22.62	0-2	2
1717.5	20025	15	16QAM	36	37	22.65	0-2	2	
1717.5	20025	15	16QAM	75	0	22.70	0-2	2	
Mid	1732.5	20175	15	QPSK	1	0	24.97	0	0
	1732.5	20175	15	QPSK	1	36	24.91	0	0
	1732.5	20175	15	QPSK	1	74	24.87	0	0
	1732.5	20175	15	QPSK	36	0	23.83	0-1	1
	1732.5	20175	15	QPSK	36	18	23.80	0-1	1
	1732.5	20175	15	QPSK	36	37	23.72	0-1	1
	1732.5	20175	15	QPSK	75	0	23.77	0-1	1
	1732.5	20175	15	16QAM	1	0	24.00	0-1	1
	1732.5	20175	15	16QAM	1	36	23.95	0-1	1
	1732.5	20175	15	16QAM	1	74	23.99	0-1	1
	1732.5	20175	15	16QAM	36	0	22.62	0-2	2
	1732.5	20175	15	16QAM	36	18	22.53	0-2	2
1732.5	20175	15	16QAM	36	37	22.49	0-2	2	
1732.5	20175	15	16QAM	75	0	22.63	0-2	2	
High	1747.5	20325	15	QPSK	1	0	24.63	0	0
	1747.5	20325	15	QPSK	1	36	24.80	0	0
	1747.5	20325	15	QPSK	1	74	24.82	0	0
	1747.5	20325	15	QPSK	36	0	23.66	0-1	1
	1747.5	20325	15	QPSK	36	18	23.52	0-1	1
	1747.5	20325	15	QPSK	36	37	23.49	0-1	1
	1747.5	20325	15	QPSK	75	0	23.69	0-1	1
	1747.5	20325	15	16QAM	1	0	23.90	0-1	1
	1747.5	20325	15	16QAM	1	36	23.81	0-1	1
	1747.5	20325	15	16QAM	1	74	23.78	0-1	1
	1747.5	20325	15	16QAM	36	0	22.42	0-2	2
	1747.5	20325	15	16QAM	36	18	22.31	0-2	2
1747.5	20325	15	16QAM	36	37	22.31	0-2	2	
1747.5	20325	15	16QAM	75	0	22.56	0-2	2	



FCC ID: ZNFV930	 PCTEST <small>ENGINEERING LABORATORY, INC.</small>	SAR EVALUATION REPORT		Reviewed by: Quality Manager
Document S/N: OY1506161253-R2.ZNF	Test Dates: 06/17/15 - 06/23/15	DUT Type: Portable Tablet		Page 36 of 88

Table 8-21
LTE Band 4 (AWS) Conducted Powers - 10 MHz Bandwidth
Maximum Power

	Frequency [MHz]	Channel	Bandwidth [MHz]	Modulation	RB Size	RB Offset	Conducted Power [dBm]	MPR Allowed per 3GPP [dB]	MPR [dB]
Low	1715	20000	10	QPSK	1	0	24.74	0	0
	1715	20000	10	QPSK	1	25	24.89	0	0
	1715	20000	10	QPSK	1	49	25.00	0	0
	1715	20000	10	QPSK	25	0	23.77	0-1	1
	1715	20000	10	QPSK	25	12	23.75	0-1	1
	1715	20000	10	QPSK	25	25	23.80	0-1	1
	1715	20000	10	QPSK	50	0	23.77	0-1	1
	1715	20000	10	16QAM	1	0	23.95	0-1	1
	1715	20000	10	16QAM	1	25	23.98	0-1	1
	1715	20000	10	16QAM	1	49	24.00	0-1	1
	1715	20000	10	16QAM	25	0	22.54	0-2	2
	1715	20000	10	16QAM	25	12	22.60	0-2	2
	1715	20000	10	16QAM	25	25	22.46	0-2	2
	1715	20000	10	16QAM	50	0	22.64	0-2	2
Mid	1732.5	20175	10	QPSK	1	0	24.97	0	0
	1732.5	20175	10	QPSK	1	25	24.93	0	0
	1732.5	20175	10	QPSK	1	49	24.92	0	0
	1732.5	20175	10	QPSK	25	0	23.85	0-1	1
	1732.5	20175	10	QPSK	25	12	23.65	0-1	1
	1732.5	20175	10	QPSK	25	25	23.65	0-1	1
	1732.5	20175	10	QPSK	50	0	23.72	0-1	1
	1732.5	20175	10	16QAM	1	0	24.00	0-1	1
	1732.5	20175	10	16QAM	1	25	23.89	0-1	1
	1732.5	20175	10	16QAM	1	49	23.96	0-1	1
	1732.5	20175	10	16QAM	25	0	22.64	0-2	2
	1732.5	20175	10	16QAM	25	12	22.57	0-2	2
	1732.5	20175	10	16QAM	25	25	22.41	0-2	2
	1732.5	20175	10	16QAM	50	0	22.52	0-2	2
High	1750	20350	10	QPSK	1	0	24.85	0	0
	1750	20350	10	QPSK	1	25	24.76	0	0
	1750	20350	10	QPSK	1	49	24.86	0	0
	1750	20350	10	QPSK	25	0	23.52	0-1	1
	1750	20350	10	QPSK	25	12	23.50	0-1	1
	1750	20350	10	QPSK	25	25	23.46	0-1	1
	1750	20350	10	QPSK	50	0	23.54	0-1	1
	1750	20350	10	16QAM	1	0	23.78	0-1	1
	1750	20350	10	16QAM	1	25	23.63	0-1	1
	1750	20350	10	16QAM	1	49	23.82	0-1	1
	1750	20350	10	16QAM	25	0	22.29	0-2	2
	1750	20350	10	16QAM	25	12	22.29	0-2	2
	1750	20350	10	16QAM	25	25	22.32	0-2	2
	1750	20350	10	16QAM	50	0	22.40	0-2	2



FCC ID: ZNFV930	 PCTEST <small>ENGINEERING LABORATORY, INC.</small>	SAR EVALUATION REPORT		Reviewed by: Quality Manager
Document S/N: OY1506161253-R2.ZNF	Test Dates: 06/17/15 - 06/23/15	DUT Type: Portable Tablet		Page 37 of 88

Table 8-22
LTE Band 4 (AWS) Conducted Powers - 5 MHz Bandwidth
Maximum Power

	Frequency [MHz]	Channel	Bandwidth [MHz]	Modulation	RB Size	RB Offset	Conducted Power [dBm]	MPR Allowed per 3GPP [dB]	MPR [dB]
Low	1712.5	19975	5	QPSK	1	0	24.61	0	0
	1712.5	19975	5	QPSK	1	12	24.84	0	0
	1712.5	19975	5	QPSK	1	24	24.78	0	0
	1712.5	19975	5	QPSK	12	0	23.68	0-1	1
	1712.5	19975	5	QPSK	12	6	23.80	0-1	1
	1712.5	19975	5	QPSK	12	13	23.75	0-1	1
	1712.5	19975	5	QPSK	25	0	23.74	0-1	1
	1712.5	19975	5	16-QAM	1	0	23.57	0-1	1
	1712.5	19975	5	16-QAM	1	12	23.76	0-1	1
	1712.5	19975	5	16-QAM	1	24	23.72	0-1	1
	1712.5	19975	5	16-QAM	12	0	22.43	0-2	2
	1712.5	19975	5	16-QAM	12	6	22.49	0-2	2
	1712.5	19975	5	16-QAM	12	13	22.53	0-2	2
1712.5	19975	5	16-QAM	25	0	22.61	0-2	2	
Mid	1732.5	20175	5	QPSK	1	0	25.00	0	0
	1732.5	20175	5	QPSK	1	12	24.96	0	0
	1732.5	20175	5	QPSK	1	24	24.92	0	0
	1732.5	20175	5	QPSK	12	0	23.81	0-1	1
	1732.5	20175	5	QPSK	12	6	23.70	0-1	1
	1732.5	20175	5	QPSK	12	13	23.61	0-1	1
	1732.5	20175	5	QPSK	25	0	23.73	0-1	1
	1732.5	20175	5	16-QAM	1	0	24.00	0-1	1
	1732.5	20175	5	16-QAM	1	12	23.91	0-1	1
	1732.5	20175	5	16-QAM	1	24	23.83	0-1	1
	1732.5	20175	5	16-QAM	12	0	22.57	0-2	2
	1732.5	20175	5	16-QAM	12	6	22.48	0-2	2
	1732.5	20175	5	16-QAM	12	13	22.43	0-2	2
1732.5	20175	5	16-QAM	25	0	22.46	0-2	2	
High	1752.5	20375	5	QPSK	1	0	24.90	0	0
	1752.5	20375	5	QPSK	1	12	24.78	0	0
	1752.5	20375	5	QPSK	1	24	24.96	0	0
	1752.5	20375	5	QPSK	12	0	23.55	0-1	1
	1752.5	20375	5	QPSK	12	6	23.46	0-1	1
	1752.5	20375	5	QPSK	12	13	23.48	0-1	1
	1752.5	20375	5	QPSK	25	0	23.54	0-1	1
	1752.5	20375	5	16-QAM	1	0	23.74	0-1	1
	1752.5	20375	5	16-QAM	1	12	23.72	0-1	1
	1752.5	20375	5	16-QAM	1	24	23.83	0-1	1
	1752.5	20375	5	16-QAM	12	0	22.30	0-2	2
	1752.5	20375	5	16-QAM	12	6	22.21	0-2	2
	1752.5	20375	5	16-QAM	12	13	22.26	0-2	2
1752.5	20375	5	16-QAM	25	0	22.38	0-2	2	



FCC ID: ZNFV930	 PCTEST <small>ENGINEERING LABORATORY, INC.</small>	SAR EVALUATION REPORT		Reviewed by: Quality Manager
Document S/N: OY1506161253-R2.ZNF	Test Dates: 06/17/15 - 06/23/15	DUT Type: Portable Tablet		Page 38 of 88

Table 8-23
LTE Band 4 (AWS) Conducted Powers - 3 MHz Bandwidth
Maximum Power

	Frequency [MHz]	Channel	Bandwidth [MHz]	Modulation	RB Size	RB Offset	Conducted Power [dBm]	MPR Allowed per 3GPP [dB]	MPR [dB]
Low	1711.5	19965	3	QPSK	1	0	24.83	0	0
	1711.5	19965	3	QPSK	1	7	24.85	0	0
	1711.5	19965	3	QPSK	1	14	24.96	0	0
	1711.5	19965	3	QPSK	8	0	23.69	0-1	1
	1711.5	19965	3	QPSK	8	4	23.67	0-1	1
	1711.5	19965	3	QPSK	8	7	23.64	0-1	1
	1711.5	19965	3	QPSK	15	0	23.65	0-1	1
	1711.5	19965	3	16-QAM	1	0	23.96	0-1	1
	1711.5	19965	3	16-QAM	1	7	23.96	0-1	1
	1711.5	19965	3	16-QAM	1	14	24.00	0-1	1
	1711.5	19965	3	16-QAM	8	0	22.33	0-2	2
	1711.5	19965	3	16-QAM	8	4	22.33	0-2	2
1711.5	19965	3	16-QAM	8	7	22.32	0-2	2	
1711.5	19965	3	16-QAM	15	0	22.40	0-2	2	
Mid	1732.5	20175	3	QPSK	1	0	25.00	0	0
	1732.5	20175	3	QPSK	1	7	24.97	0	0
	1732.5	20175	3	QPSK	1	14	24.89	0	0
	1732.5	20175	3	QPSK	8	0	23.72	0-1	1
	1732.5	20175	3	QPSK	8	4	23.68	0-1	1
	1732.5	20175	3	QPSK	8	7	23.74	0-1	1
	1732.5	20175	3	QPSK	15	0	23.77	0-1	1
	1732.5	20175	3	16-QAM	1	0	24.00	0-1	1
	1732.5	20175	3	16-QAM	1	7	23.90	0-1	1
	1732.5	20175	3	16-QAM	1	14	23.84	0-1	1
	1732.5	20175	3	16-QAM	8	0	22.43	0-2	2
	1732.5	20175	3	16-QAM	8	4	22.38	0-2	2
1732.5	20175	3	16-QAM	8	7	22.44	0-2	2	
1732.5	20175	3	16-QAM	15	0	22.46	0-2	2	
High	1753.5	20385	3	QPSK	1	0	24.77	0	0
	1753.5	20385	3	QPSK	1	7	24.83	0	0
	1753.5	20385	3	QPSK	1	14	24.84	0	0
	1753.5	20385	3	QPSK	8	0	23.46	0-1	1
	1753.5	20385	3	QPSK	8	4	23.48	0-1	1
	1753.5	20385	3	QPSK	8	7	23.61	0-1	1
	1753.5	20385	3	QPSK	15	0	23.48	0-1	1
	1753.5	20385	3	16-QAM	1	0	23.64	0-1	1
	1753.5	20385	3	16-QAM	1	7	23.71	0-1	1
	1753.5	20385	3	16-QAM	1	14	23.75	0-1	1
	1753.5	20385	3	16-QAM	8	0	22.30	0-2	2
	1753.5	20385	3	16-QAM	8	4	22.21	0-2	2
1753.5	20385	3	16-QAM	8	7	22.34	0-2	2	
1753.5	20385	3	16-QAM	15	0	22.28	0-2	2	



FCC ID: ZNFV930	 PCTEST <small>ENGINEERING LABORATORY, INC.</small>	SAR EVALUATION REPORT		Reviewed by: Quality Manager
Document S/N: OY1506161253-R2.ZNF	Test Dates: 06/17/15 - 06/23/15	DUT Type: Portable Tablet		Page 39 of 88

Table 8-24
LTE Band 4 (AWS) Conducted Powers - 1.4 MHz Bandwidth
Maximum Power

	Frequency [MHz]	Channel	Bandwidth [MHz]	Modulation	RB Size	RB Offset	Conducted Power [dBm]	MPR Allowed per 3GPP [dB]	MPR [dB]
Low	1710.7	19957	1.4	QPSK	1	0	24.94	0	0
	1710.7	19957	1.4	QPSK	1	2	24.88	0	0
	1710.7	19957	1.4	QPSK	1	5	25.00	0	0
	1710.7	19957	1.4	QPSK	3	0	24.78	0	0
	1710.7	19957	1.4	QPSK	3	2	24.91	0	0
	1710.7	19957	1.4	QPSK	3	3	24.88	0	0
	1710.7	19957	1.4	QPSK	6	0	23.57	0-1	1
	1710.7	19957	1.4	16-QAM	1	0	23.48	0-1	1
	1710.7	19957	1.4	16-QAM	1	2	23.46	0-1	1
	1710.7	19957	1.4	16-QAM	1	5	23.59	0-1	1
	1710.7	19957	1.4	16-QAM	3	0	23.55	0-1	1
	1710.7	19957	1.4	16-QAM	3	2	23.70	0-1	1
1710.7	19957	1.4	16-QAM	3	3	23.70	0-1	1	
1710.7	19957	1.4	16-QAM	6	0	22.46	0-2	2	
Mid	1732.5	20175	1.4	QPSK	1	0	25.00	0	0
	1732.5	20175	1.4	QPSK	1	2	24.93	0	0
	1732.5	20175	1.4	QPSK	1	5	24.99	0	0
	1732.5	20175	1.4	QPSK	3	0	24.89	0	0
	1732.5	20175	1.4	QPSK	3	2	24.93	0	0
	1732.5	20175	1.4	QPSK	3	3	24.92	0	0
	1732.5	20175	1.4	QPSK	6	0	23.74	0-1	1
	1732.5	20175	1.4	16-QAM	1	0	23.99	0-1	1
	1732.5	20175	1.4	16-QAM	1	2	23.92	0-1	1
	1732.5	20175	1.4	16-QAM	1	5	23.99	0-1	1
	1732.5	20175	1.4	16-QAM	3	0	23.78	0-1	1
	1732.5	20175	1.4	16-QAM	3	2	23.76	0-1	1
1732.5	20175	1.4	16-QAM	3	3	23.81	0-1	1	
1732.5	20175	1.4	16-QAM	6	0	22.48	0-2	2	
High	1754.3	20393	1.4	QPSK	1	0	24.86	0	0
	1754.3	20393	1.4	QPSK	1	2	24.80	0	0
	1754.3	20393	1.4	QPSK	1	5	24.80	0	0
	1754.3	20393	1.4	QPSK	3	0	24.87	0	0
	1754.3	20393	1.4	QPSK	3	2	24.85	0	0
	1754.3	20393	1.4	QPSK	3	3	24.84	0	0
	1754.3	20393	1.4	QPSK	6	0	23.65	0-1	1
	1754.3	20393	1.4	16-QAM	1	0	23.62	0-1	1
	1754.3	20393	1.4	16-QAM	1	2	23.55	0-1	1
	1754.3	20393	1.4	16-QAM	1	5	23.66	0-1	1
	1754.3	20393	1.4	16-QAM	3	0	23.63	0-1	1
	1754.3	20393	1.4	16-QAM	3	2	23.60	0-1	1
1754.3	20393	1.4	16-QAM	3	3	23.65	0-1	1	
1754.3	20393	1.4	16-QAM	6	0	22.41	0-2	2	



FCC ID: ZNFV930	 PCTEST <small>ENGINEERING LABORATORY, INC.</small>	SAR EVALUATION REPORT		Reviewed by: Quality Manager
Document S/N: OY1506161253-R2.ZNF	Test Dates: 06/17/15 - 06/23/15	DUT Type: Portable Tablet		Page 40 of 88

Table 8-25
LTE Band 4 (AWS) Conducted Powers - 20 MHz Bandwidth
Reduced Power – Body at 0.0 cm

	Frequency [MHz]	Channel	Bandwidth [MHz]	Modulation	RB Size	RB Offset	Conducted Power [dBm]	MPR Allowed per 3GPP [dB]	MPR [dB]
Mid	1732.5	20175	20	QPSK	1	0	12.09	0	0
	1732.5	20175	20	QPSK	1	50	12.38	0	0
	1732.5	20175	20	QPSK	1	99	11.80	0	0
	1732.5	20175	20	QPSK	50	0	12.08	0-1	0
	1732.5	20175	20	QPSK	50	25	12.26	0-1	0
	1732.5	20175	20	QPSK	50	50	11.99	0-1	0
	1732.5	20175	20	QPSK	100	0	12.08	0-1	0
	1732.5	20175	20	16QAM	1	0	12.02	0-1	0
	1732.5	20175	20	16QAM	1	50	12.50	0-1	0
	1732.5	20175	20	16QAM	1	99	11.81	0-1	0
	1732.5	20175	20	16QAM	50	0	12.14	0-2	0
	1732.5	20175	20	16QAM	50	25	12.30	0-2	0
	1732.5	20175	20	16QAM	50	50	12.05	0-2	0
	1732.5	20175	20	16QAM	100	0	12.13	0-2	0

Note: LTE Band 4 (AWS) at 20 MHz bandwidth does not support three non-overlapping channels. Per KDB Publication 941225 D05v02, when a device supports overlapping channel assignment in a channel bandwidth configuration, the middle channel of the group of overlapping channels should be selected for testing.



FCC ID: ZNFV930	 PCTEST <small>ENGINEERING LABORATORY, INC.</small>	SAR EVALUATION REPORT		Reviewed by: Quality Manager
Document S/N: OY1506161253-R2.ZNF	Test Dates: 06/17/15 - 06/23/15	DUT Type: Portable Tablet		Page 41 of 88

Table 8-26
LTE Band 4 (AWS) Conducted Powers - 15 MHz Bandwidth
Reduced Power – Body at 0.0 cm

	Frequency [MHz]	Channel	Bandwidth [MHz]	Modulation	RB Size	RB Offset	Conducted Power [dBm]	MPR Allowed per 3GPP [dB]	MPR [dB]
Low	1717.5	20025	15	QPSK	1	0	11.61	0	0
	1717.5	20025	15	QPSK	1	36	11.62	0	0
	1717.5	20025	15	QPSK	1	74	11.76	0	0
	1717.5	20025	15	QPSK	36	0	11.50	0-1	1
	1717.5	20025	15	QPSK	36	18	11.61	0-1	0
	1717.5	20025	15	QPSK	36	37	11.54	0-1	0
	1717.5	20025	15	QPSK	75	0	11.52	0-1	0
	1717.5	20025	15	16QAM	1	0	11.73	0-1	0
	1717.5	20025	15	16QAM	1	36	11.91	0-1	0
	1717.5	20025	15	16QAM	1	74	11.85	0-1	0
	1717.5	20025	15	16QAM	36	0	11.56	0-2	0
	1717.5	20025	15	16QAM	36	18	11.67	0-2	0
1717.5	20025	15	16QAM	36	37	11.63	0-2	0	
1717.5	20025	15	16QAM	75	0	11.59	0-2	0	
Mid	1732.5	20175	15	QPSK	1	0	11.61	0	0
	1732.5	20175	15	QPSK	1	36	11.63	0	0
	1732.5	20175	15	QPSK	1	74	11.50	0	0
	1732.5	20175	15	QPSK	36	0	11.55	0-1	0
	1732.5	20175	15	QPSK	36	18	11.59	0-1	0
	1732.5	20175	15	QPSK	36	37	11.52	0-1	0
	1732.5	20175	15	QPSK	75	0	11.60	0-1	0
	1732.5	20175	15	16QAM	1	0	12.15	0-1	0
	1732.5	20175	15	16QAM	1	36	12.23	0-1	0
	1732.5	20175	15	16QAM	1	74	12.00	0-1	0
	1732.5	20175	15	16QAM	36	0	11.65	0-2	0
	1732.5	20175	15	16QAM	36	18	11.63	0-2	0
1732.5	20175	15	16QAM	36	37	11.60	0-2	0	
1732.5	20175	15	16QAM	75	0	11.67	0-2	0	
High	1747.5	20325	15	QPSK	1	0	11.54	0	0
	1747.5	20325	15	QPSK	1	36	11.96	0	0
	1747.5	20325	15	QPSK	1	74	11.50	0	0
	1747.5	20325	15	QPSK	36	0	12.00	0-1	0
	1747.5	20325	15	QPSK	36	18	12.02	0-1	0
	1747.5	20325	15	QPSK	36	37	11.93	0-1	0
	1747.5	20325	15	QPSK	75	0	12.01	0-1	0
	1747.5	20325	15	16QAM	1	0	11.51	0-1	0
	1747.5	20325	15	16QAM	1	36	11.59	0-1	0
	1747.5	20325	15	16QAM	1	74	11.53	0-1	0
	1747.5	20325	15	16QAM	36	0	11.54	0-2	0
	1747.5	20325	15	16QAM	36	18	11.51	0-2	0
1747.5	20325	15	16QAM	36	37	11.52	0-2	0	
1747.5	20325	15	16QAM	75	0	11.59	0-2	0	



FCC ID: ZNFV930	 PCTEST <small>ENGINEERING LABORATORY, INC.</small>	SAR EVALUATION REPORT		Reviewed by: Quality Manager
Document S/N: OY1506161253-R2.ZNF	Test Dates: 06/17/15 - 06/23/15	DUT Type: Portable Tablet		Page 42 of 88

Table 8-27
LTE Band 4 (AWS) Conducted Powers - 10 MHz Bandwidth
Reduced Power – Body at 0.0 cm

	Frequency [MHz]	Channel	Bandwidth [MHz]	Modulation	RB Size	RB Offset	Conducted Power [dBm]	MPR Allowed per 3GPP [dB]	MPR [dB]
Low	1715	20000	10	QPSK	1	0	11.50	0	0
	1715	20000	10	QPSK	1	25	11.51	0	0
	1715	20000	10	QPSK	1	49	11.60	0	0
	1715	20000	10	QPSK	25	0	11.52	0-1	0
	1715	20000	10	QPSK	25	12	11.58	0-1	0
	1715	20000	10	QPSK	25	25	11.52	0-1	0
	1715	20000	10	QPSK	50	0	11.61	0-1	0
	1715	20000	10	16QAM	1	0	11.50	0-1	0
	1715	20000	10	16QAM	1	25	11.72	0-1	0
	1715	20000	10	16QAM	1	49	11.50	0-1	0
	1715	20000	10	16QAM	25	0	11.54	0-2	0
	1715	20000	10	16QAM	25	12	11.53	0-2	0
	1715	20000	10	16QAM	25	25	11.62	0-2	0
1715	20000	10	16QAM	50	0	11.54	0-2	0	
Mid	1732.5	20175	10	QPSK	1	0	11.54	0	0
	1732.5	20175	10	QPSK	1	25	11.54	0	0
	1732.5	20175	10	QPSK	1	49	11.53	0	0
	1732.5	20175	10	QPSK	25	0	11.53	0-1	0
	1732.5	20175	10	QPSK	25	12	11.52	0-1	0
	1732.5	20175	10	QPSK	25	25	11.51	0-1	0
	1732.5	20175	10	QPSK	50	0	11.53	0-1	0
	1732.5	20175	10	16QAM	1	0	11.52	0-1	0
	1732.5	20175	10	16QAM	1	25	11.57	0-1	0
	1732.5	20175	10	16QAM	1	49	11.50	0-1	0
	1732.5	20175	10	16QAM	25	0	11.55	0-2	0
	1732.5	20175	10	16QAM	25	12	11.55	0-2	0
	1732.5	20175	10	16QAM	25	25	11.57	0-2	0
1732.5	20175	10	16QAM	50	0	11.60	0-2	0	
High	1750	20350	10	QPSK	1	0	11.50	0	0
	1750	20350	10	QPSK	1	25	11.89	0	0
	1750	20350	10	QPSK	1	49	11.72	0	0
	1750	20350	10	QPSK	25	0	11.90	0-1	0
	1750	20350	10	QPSK	25	12	11.92	0-1	0
	1750	20350	10	QPSK	25	25	11.87	0-1	0
	1750	20350	10	QPSK	50	0	11.93	0-1	0
	1750	20350	10	16QAM	1	0	11.69	0-1	0
	1750	20350	10	16QAM	1	25	11.75	0-1	0
	1750	20350	10	16QAM	1	49	11.60	0-1	0
	1750	20350	10	16QAM	25	0	11.50	0-2	0
	1750	20350	10	16QAM	25	12	11.51	0-2	0
	1750	20350	10	16QAM	25	25	11.53	0-2	0
1750	20350	10	16QAM	50	0	11.52	0-2	0	



FCC ID: ZNFV930	 PCTEST <small>ENGINEERING LABORATORY, INC.</small>	SAR EVALUATION REPORT		Reviewed by: Quality Manager
Document S/N: OY1506161253-R2.ZNF	Test Dates: 06/17/15 - 06/23/15	DUT Type: Portable Tablet		Page 43 of 88

Table 8-28
LTE Band 4 (AWS) Conducted Powers - 5 MHz Bandwidth
Reduced Power – Body at 0.0 cm

	Frequency [MHz]	Channel	Bandwidth [MHz]	Modulation	RB Size	RB Offset	Conducted Power [dBm]	MPR Allowed per 3GPP [dB]	MPR [dB]
Low	1712.5	19975	5	QPSK	1	0	11.74	0	0
	1712.5	19975	5	QPSK	1	12	11.68	0	0
	1712.5	19975	5	QPSK	1	24	11.75	0	0
	1712.5	19975	5	QPSK	12	0	11.68	0-1	0
	1712.5	19975	5	QPSK	12	6	11.74	0-1	0
	1712.5	19975	5	QPSK	12	13	11.79	0-1	0
	1712.5	19975	5	QPSK	25	0	11.74	0-1	0
	1712.5	19975	5	16-QAM	1	0	12.02	0-1	0
	1712.5	19975	5	16-QAM	1	12	12.16	0-1	0
	1712.5	19975	5	16-QAM	1	24	11.86	0-1	0
	1712.5	19975	5	16-QAM	12	0	11.74	0-2	0
	1712.5	19975	5	16-QAM	12	6	11.80	0-2	0
1712.5	19975	5	16-QAM	12	13	11.86	0-2	0	
1712.5	19975	5	16-QAM	25	0	11.82	0-2	0	
Mid	1732.5	20175	5	QPSK	1	0	11.93	0	0
	1732.5	20175	5	QPSK	1	12	11.86	0	0
	1732.5	20175	5	QPSK	1	24	11.95	0	0
	1732.5	20175	5	QPSK	12	0	11.80	0-1	0
	1732.5	20175	5	QPSK	12	6	11.81	0-1	0
	1732.5	20175	5	QPSK	12	13	11.80	0-1	0
	1732.5	20175	5	QPSK	25	0	11.82	0-1	0
	1732.5	20175	5	16-QAM	1	0	12.27	0-1	0
	1732.5	20175	5	16-QAM	1	12	12.33	0-1	0
	1732.5	20175	5	16-QAM	1	24	12.35	0-1	0
	1732.5	20175	5	16-QAM	12	0	12.06	0-2	0
	1732.5	20175	5	16-QAM	12	6	12.07	0-2	0
1732.5	20175	5	16-QAM	12	13	12.09	0-2	0	
1732.5	20175	5	16-QAM	25	0	11.86	0-2	0	
High	1752.5	20375	5	QPSK	1	0	12.36	0	0
	1752.5	20375	5	QPSK	1	12	12.06	0	0
	1752.5	20375	5	QPSK	1	24	12.12	0	0
	1752.5	20375	5	QPSK	12	0	12.22	0-1	0
	1752.5	20375	5	QPSK	12	6	12.13	0-1	0
	1752.5	20375	5	QPSK	12	13	12.21	0-1	0
	1752.5	20375	5	QPSK	25	0	12.22	0-1	0
	1752.5	20375	5	16-QAM	1	0	12.18	0-1	0
	1752.5	20375	5	16-QAM	1	12	12.05	0-1	0
	1752.5	20375	5	16-QAM	1	24	12.04	0-1	0
	1752.5	20375	5	16-QAM	12	0	11.72	0-2	0
	1752.5	20375	5	16-QAM	12	6	11.59	0-2	0
1752.5	20375	5	16-QAM	12	13	11.69	0-2	0	
1752.5	20375	5	16-QAM	25	0	11.75	0-2	0	



FCC ID: ZNFV930	 PCTEST <small>ENGINEERING LABORATORY, INC.</small>	SAR EVALUATION REPORT		Reviewed by: Quality Manager
Document S/N: OY1506161253-R2.ZNF	Test Dates: 06/17/15 - 06/23/15	DUT Type: Portable Tablet		Page 44 of 88

Table 8-29
LTE Band 4 (AWS) Conducted Powers - 3 MHz Bandwidth
Reduced Power – Body at 0.0 cm

	Frequency [MHz]	Channel	Bandwidth [MHz]	Modulation	RB Size	RB Offset	Conducted Power [dBm]	MPR Allowed per 3GPP [dB]	MPR [dB]
Low	1711.5	19965	3	QPSK	1	0	11.77	0	0
	1711.5	19965	3	QPSK	1	7	11.60	0	0
	1711.5	19965	3	QPSK	1	14	11.75	0	0
	1711.5	19965	3	QPSK	8	0	11.66	0-1	0
	1711.5	19965	3	QPSK	8	4	11.67	0-1	0
	1711.5	19965	3	QPSK	8	7	11.65	0-1	0
	1711.5	19965	3	QPSK	15	0	11.63	0-1	0
	1711.5	19965	3	16-QAM	1	0	12.09	0-1	0
	1711.5	19965	3	16-QAM	1	7	11.94	0-1	0
	1711.5	19965	3	16-QAM	1	14	12.09	0-1	0
	1711.5	19965	3	16-QAM	8	0	11.81	0-2	0
	1711.5	19965	3	16-QAM	8	4	11.79	0-2	0
1711.5	19965	3	16-QAM	8	7	11.75	0-2	0	
1711.5	19965	3	16-QAM	15	0	11.74	0-2	0	
Mid	1732.5	20175	3	QPSK	1	0	11.82	0	0
	1732.5	20175	3	QPSK	1	7	11.74	0	0
	1732.5	20175	3	QPSK	1	14	11.83	0	0
	1732.5	20175	3	QPSK	8	0	11.73	0-1	0
	1732.5	20175	3	QPSK	8	4	11.76	0-1	0
	1732.5	20175	3	QPSK	8	7	11.74	0-1	0
	1732.5	20175	3	QPSK	15	0	11.73	0-1	0
	1732.5	20175	3	16-QAM	1	0	12.05	0-1	0
	1732.5	20175	3	16-QAM	1	7	11.96	0-1	0
	1732.5	20175	3	16-QAM	1	14	12.01	0-1	0
	1732.5	20175	3	16-QAM	8	0	11.81	0-2	0
	1732.5	20175	3	16-QAM	8	4	11.87	0-2	0
1732.5	20175	3	16-QAM	8	7	11.81	0-2	0	
1732.5	20175	3	16-QAM	15	0	11.71	0-2	0	
High	1753.5	20385	3	QPSK	1	0	12.20	0	0
	1753.5	20385	3	QPSK	1	7	12.09	0	0
	1753.5	20385	3	QPSK	1	14	12.12	0	0
	1753.5	20385	3	QPSK	8	0	12.13	0-1	0
	1753.5	20385	3	QPSK	8	4	12.16	0-1	0
	1753.5	20385	3	QPSK	8	7	12.10	0-1	0
	1753.5	20385	3	QPSK	15	0	12.12	0-1	0
	1753.5	20385	3	16-QAM	1	0	12.34	0-1	0
	1753.5	20385	3	16-QAM	1	7	12.26	0-1	0
	1753.5	20385	3	16-QAM	1	14	12.23	0-1	0
	1753.5	20385	3	16-QAM	8	0	11.72	0-2	0
	1753.5	20385	3	16-QAM	8	4	11.79	0-2	0
1753.5	20385	3	16-QAM	8	7	11.69	0-2	0	
1753.5	20385	3	16-QAM	15	0	11.64	0-2	0	





FCC ID: ZNFV930	 PCTEST <small>ENGINEERING LABORATORY, INC.</small>	SAR EVALUATION REPORT		Reviewed by: Quality Manager
Document S/N: OY1506161253-R2.ZNF	Test Dates: 06/17/15 - 06/23/15	DUT Type: Portable Tablet		Page 45 of 88

Table 8-30
LTE Band 4 (AWS) Conducted Powers – 1.4 MHz Bandwidth
Reduced Power – Body at 0.0 cm

	Frequency [MHz]	Channel	Bandwidth [MHz]	Modulation	RB Size	RB Offset	Conducted Power [dBm]	MPR Allowed per 3GPP [dB]	MPR [dB]
Low	1710.7	19957	1.4	QPSK	1	0	11.69	0	0
	1710.7	19957	1.4	QPSK	1	2	11.82	0	0
	1710.7	19957	1.4	QPSK	1	5	11.71	0	0
	1710.7	19957	1.4	QPSK	3	0	11.57	0	0
	1710.7	19957	1.4	QPSK	3	2	11.73	0	0
	1710.7	19957	1.4	QPSK	3	3	11.58	0	0
	1710.7	19957	1.4	QPSK	6	0	11.62	0-1	0
	1710.7	19957	1.4	16-QAM	1	0	11.78	0-1	0
	1710.7	19957	1.4	16-QAM	1	2	11.97	0-1	0
	1710.7	19957	1.4	16-QAM	1	5	11.88	0-1	0
	1710.7	19957	1.4	16-QAM	3	0	11.79	0-1	0
	1710.7	19957	1.4	16-QAM	3	2	12.00	0-1	0
1710.7	19957	1.4	16-QAM	3	3	11.84	0-1	0	
1710.7	19957	1.4	16-QAM	6	0	11.75	0-2	0	
Mid	1732.5	20175	1.4	QPSK	1	0	11.53	0	0
	1732.5	20175	1.4	QPSK	1	2	11.73	0	0
	1732.5	20175	1.4	QPSK	1	5	11.53	0	0
	1732.5	20175	1.4	QPSK	3	0	11.73	0	0
	1732.5	20175	1.4	QPSK	3	2	11.79	0	0
	1732.5	20175	1.4	QPSK	3	3	11.75	0	0
	1732.5	20175	1.4	QPSK	6	0	11.76	0-1	0
	1732.5	20175	1.4	16-QAM	1	0	11.71	0-1	0
	1732.5	20175	1.4	16-QAM	1	2	11.90	0-1	0
	1732.5	20175	1.4	16-QAM	1	5	11.76	0-1	0
	1732.5	20175	1.4	16-QAM	3	0	11.89	0-1	0
	1732.5	20175	1.4	16-QAM	3	2	11.95	0-1	0
1732.5	20175	1.4	16-QAM	3	3	11.89	0-1	0	
1732.5	20175	1.4	16-QAM	6	0	11.76	0-2	0	
High	1754.3	20393	1.4	QPSK	1	0	11.92	0	0
	1754.3	20393	1.4	QPSK	1	2	12.05	0	0
	1754.3	20393	1.4	QPSK	1	5	11.88	0	0
	1754.3	20393	1.4	QPSK	3	0	12.06	0	0
	1754.3	20393	1.4	QPSK	3	2	12.09	0	0
	1754.3	20393	1.4	QPSK	3	3	12.02	0	0
	1754.3	20393	1.4	QPSK	6	0	12.04	0-1	0
	1754.3	20393	1.4	16-QAM	1	0	11.65	0-1	0
	1754.3	20393	1.4	16-QAM	1	2	11.83	0-1	0
	1754.3	20393	1.4	16-QAM	1	5	11.64	0-1	0
	1754.3	20393	1.4	16-QAM	3	0	11.52	0-1	0
	1754.3	20393	1.4	16-QAM	3	2	11.54	0-1	0
1754.3	20393	1.4	16-QAM	3	3	11.56	0-1	0	
1754.3	20393	1.4	16-QAM	6	0	11.51	0-2	0	

FCC ID: ZNFV930	 PCTEST <small>ENGINEERING LABORATORY, INC.</small>	SAR EVALUATION REPORT		Reviewed by: Quality Manager
Document S/N: OY1506161253-R2.ZNF	Test Dates: 06/17/15 - 06/23/15	DUT Type: Portable Tablet		Page 46 of 88

8.2.4 LTE Band 2 (PCS)

Table 8-31
LTE Band 2 (PCS) Conducted Powers - 20 MHz Bandwidth
Maximum Power

	Frequency [MHz]	Channel	Bandwidth [MHz]	Modulation	RB Size	RB Offset	Conducted Power [dBm]	MPR Allowed per 3GPP [dB]	MPR [dB]
Low	1860	18700	20	QPSK	1	0	24.67	0	0
	1860	18700	20	QPSK	1	50	24.80	0	0
	1860	18700	20	QPSK	1	99	24.90	0	0
	1860	18700	20	QPSK	50	0	23.97	0-1	1
	1860	18700	20	QPSK	50	25	23.91	0-1	1
	1860	18700	20	QPSK	50	50	23.89	0-1	1
	1860	18700	20	QPSK	100	0	23.87	0-1	1
	1860	18700	20	16QAM	1	0	23.56	0-1	1
	1860	18700	20	16QAM	1	50	23.60	0-1	1
	1860	18700	20	16QAM	1	99	23.68	0-1	1
	1860	18700	20	16QAM	50	0	22.93	0-2	2
	1860	18700	20	16QAM	50	25	22.85	0-2	2
1860	18700	20	16QAM	50	50	22.87	0-2	2	
1860	18700	20	16QAM	100	0	22.84	0-2	2	
Mid	1880.0	18900	20	QPSK	1	0	25.00	0	0
	1880.0	18900	20	QPSK	1	50	24.98	0	0
	1880.0	18900	20	QPSK	1	99	24.99	0	0
	1880.0	18900	20	QPSK	50	0	23.87	0-1	1
	1880.0	18900	20	QPSK	50	25	23.86	0-1	1
	1880.0	18900	20	QPSK	50	50	23.87	0-1	1
	1880.0	18900	20	QPSK	100	0	23.88	0-1	1
	1880.0	18900	20	16QAM	1	0	23.96	0-1	1
	1880.0	18900	20	16QAM	1	50	23.81	0-1	1
	1880.0	18900	20	16QAM	1	99	23.96	0-1	1
	1880.0	18900	20	16QAM	50	0	22.83	0-2	2
	1880.0	18900	20	16QAM	50	25	22.93	0-2	2
1880.0	18900	20	16QAM	50	50	22.97	0-2	2	
1880.0	18900	20	16QAM	100	0	22.85	0-2	2	
High	1900	19100	20	QPSK	1	0	24.80	0	0
	1900	19100	20	QPSK	1	50	24.90	0	0
	1900	19100	20	QPSK	1	99	24.89	0	0
	1900	19100	20	QPSK	50	0	23.90	0-1	1
	1900	19100	20	QPSK	50	25	23.95	0-1	1
	1900	19100	20	QPSK	50	50	23.92	0-1	1
	1900	19100	20	QPSK	100	0	23.96	0-1	1
	1900	19100	20	16QAM	1	0	23.69	0-1	1
	1900	19100	20	16QAM	1	50	23.80	0-1	1
	1900	19100	20	16QAM	1	99	23.72	0-1	1
	1900	19100	20	16QAM	50	0	23.00	0-2	2
	1900	19100	20	16QAM	50	25	23.00	0-2	2
1900	19100	20	16QAM	50	50	22.99	0-2	2	
1900	19100	20	16QAM	100	0	22.95	0-2	2	



FCC ID: ZNFV930	 PCTEST <small>ENGINEERING LABORATORY, INC.</small>	SAR EVALUATION REPORT		Reviewed by: Quality Manager
Document S/N: OY1506161253-R2.ZNF	Test Dates: 06/17/15 - 06/23/15	DUT Type: Portable Tablet		Page 47 of 88

Table 8-32
LTE Band 2 (PCS) Conducted Powers - 15 MHz Bandwidth
Maximum Power

	Frequency [MHz]	Channel	Bandwidth [MHz]	Modulation	RB Size	RB Offset	Conducted Power [dBm]	MPR Allowed per 3GPP [dB]	MPR [dB]
Low	1857.5	18675	15	QPSK	1	0	24.90	0	0
	1857.5	18675	15	QPSK	1	36	24.87	0	0
	1857.5	18675	15	QPSK	1	74	24.75	0	0
	1857.5	18675	15	QPSK	36	0	23.96	0-1	1
	1857.5	18675	15	QPSK	36	18	23.96	0-1	1
	1857.5	18675	15	QPSK	36	37	23.91	0-1	1
	1857.5	18675	15	QPSK	75	0	23.88	0-1	1
	1857.5	18675	15	16QAM	1	0	23.72	0-1	1
	1857.5	18675	15	16QAM	1	36	23.90	0-1	1
	1857.5	18675	15	16QAM	1	74	23.85	0-1	1
	1857.5	18675	15	16QAM	36	0	22.89	0-2	2
	1857.5	18675	15	16QAM	36	18	22.91	0-2	2
1857.5	18675	15	16QAM	36	37	22.91	0-2	2	
1857.5	18675	15	16QAM	75	0	22.85	0-2	2	
Mid	1880.0	18900	15	QPSK	1	0	25.00	0	0
	1880.0	18900	15	QPSK	1	36	24.96	0	0
	1880.0	18900	15	QPSK	1	74	25.00	0	0
	1880.0	18900	15	QPSK	36	0	23.90	0-1	1
	1880.0	18900	15	QPSK	36	18	23.91	0-1	1
	1880.0	18900	15	QPSK	36	37	23.94	0-1	1
	1880.0	18900	15	QPSK	75	0	23.96	0-1	1
	1880.0	18900	15	16QAM	1	0	23.85	0-1	1
	1880.0	18900	15	16QAM	1	36	23.77	0-1	1
	1880.0	18900	15	16QAM	1	74	24.00	0-1	1
	1880.0	18900	15	16QAM	36	0	22.81	0-2	2
	1880.0	18900	15	16QAM	36	18	22.82	0-2	2
1880.0	18900	15	16QAM	36	37	22.81	0-2	2	
1880.0	18900	15	16QAM	75	0	22.99	0-2	2	
High	1902.5	19125	15	QPSK	1	0	25.00	0	0
	1902.5	19125	15	QPSK	1	36	24.97	0	0
	1902.5	19125	15	QPSK	1	74	24.98	0	0
	1902.5	19125	15	QPSK	36	0	23.97	0-1	1
	1902.5	19125	15	QPSK	36	18	23.98	0-1	1
	1902.5	19125	15	QPSK	36	37	24.00	0-1	1
	1902.5	19125	15	QPSK	75	0	23.97	0-1	1
	1902.5	19125	15	16QAM	1	0	23.75	0-1	1
	1902.5	19125	15	16QAM	1	36	23.92	0-1	1
	1902.5	19125	15	16QAM	1	74	23.94	0-1	1
	1902.5	19125	15	16QAM	36	0	23.00	0-2	2
	1902.5	19125	15	16QAM	36	18	22.99	0-2	2
1902.5	19125	15	16QAM	36	37	22.97	0-2	2	
1902.5	19125	15	16QAM	75	0	22.87	0-2	2	



FCC ID: ZNFV930	 PCTEST <small>ENGINEERING LABORATORY, INC.</small>	SAR EVALUATION REPORT		Reviewed by: Quality Manager
Document S/N: OY1506161253-R2.ZNF	Test Dates: 06/17/15 - 06/23/15	DUT Type: Portable Tablet		Page 48 of 88

Table 8-33
LTE Band 2 (PCS) Conducted Powers - 10 MHz Bandwidth
Maximum Power

	Frequency [MHz]	Channel	Bandwidth [MHz]	Modulation	RB Size	RB Offset	Conducted Power [dBm]	MPR Allowed per 3GPP [dB]	MPR [dB]
Low	1855	18650	10	QPSK	1	0	24.84	0	0
	1855	18650	10	QPSK	1	25	24.87	0	0
	1855	18650	10	QPSK	1	49	25.00	0	0
	1855	18650	10	QPSK	25	0	23.83	0-1	1
	1855	18650	10	QPSK	25	12	23.87	0-1	1
	1855	18650	10	QPSK	25	25	23.92	0-1	1
	1855	18650	10	QPSK	50	0	23.90	0-1	1
	1855	18650	10	16QAM	1	0	23.96	0-1	1
	1855	18650	10	16QAM	1	25	23.91	0-1	1
	1855	18650	10	16QAM	1	49	24.00	0-1	1
	1855	18650	10	16QAM	25	0	22.86	0-2	2
	1855	18650	10	16QAM	25	12	22.90	0-2	2
Mid	1880.0	18900	10	QPSK	1	0	24.92	0	0
	1880.0	18900	10	QPSK	1	25	24.91	0	0
	1880.0	18900	10	QPSK	1	49	25.00	0	0
	1880.0	18900	10	QPSK	25	0	23.88	0-1	1
	1880.0	18900	10	QPSK	25	12	23.91	0-1	1
	1880.0	18900	10	QPSK	25	25	23.89	0-1	1
	1880.0	18900	10	QPSK	50	0	23.86	0-1	1
	1880.0	18900	10	16QAM	1	0	23.66	0-1	1
	1880.0	18900	10	16QAM	1	25	23.75	0-1	1
	1880.0	18900	10	16QAM	1	49	23.88	0-1	1
	1880.0	18900	10	16QAM	25	0	22.91	0-2	2
	1880.0	18900	10	16QAM	25	12	22.94	0-2	2
High	1905	19150	10	QPSK	1	0	25.00	0	0
	1905	19150	10	QPSK	1	25	24.95	0	0
	1905	19150	10	QPSK	1	49	24.98	0	0
	1905	19150	10	QPSK	25	0	24.00	0-1	1
	1905	19150	10	QPSK	25	12	23.99	0-1	1
	1905	19150	10	QPSK	25	25	23.97	0-1	1
	1905	19150	10	QPSK	50	0	24.00	0-1	1
	1905	19150	10	16QAM	1	0	23.95	0-1	1
	1905	19150	10	16QAM	1	25	23.78	0-1	1
	1905	19150	10	16QAM	1	49	23.96	0-1	1
	1905	19150	10	16QAM	25	0	23.00	0-2	2
	1905	19150	10	16QAM	25	12	22.93	0-2	2
1905	19150	10	16QAM	25	25	22.92	0-2	2	
1905	19150	10	16QAM	50	0	22.96	0-2	2	



FCC ID: ZNFV930	 PCTEST <small>ENGINEERING LABORATORY, INC.</small>	SAR EVALUATION REPORT		Reviewed by: Quality Manager
Document S/N: OY1506161253-R2.ZNF	Test Dates: 06/17/15 - 06/23/15	DUT Type: Portable Tablet		Page 49 of 88

Table 8-34
LTE Band 2 (PCS) Conducted Powers - 5 MHz Bandwidth
Maximum Power

	Frequency [MHz]	Channel	Bandwidth [MHz]	Modulation	RB Size	RB Offset	Conducted Power [dBm]	MPR Allowed per 3GPP [dB]	MPR [dB]
Low	1852.5	18625	5	QPSK	1	0	24.77	0	0
	1852.5	18625	5	QPSK	1	12	24.80	0	0
	1852.5	18625	5	QPSK	1	24	24.77	0	0
	1852.5	18625	5	QPSK	12	0	23.86	0-1	1
	1852.5	18625	5	QPSK	12	6	23.82	0-1	1
	1852.5	18625	5	QPSK	12	13	23.91	0-1	1
	1852.5	18625	5	QPSK	25	0	23.85	0-1	1
	1852.5	18625	5	16-QAM	1	0	23.41	0-1	1
	1852.5	18625	5	16-QAM	1	12	23.47	0-1	1
	1852.5	18625	5	16-QAM	1	24	23.44	0-1	1
	1852.5	18625	5	16-QAM	12	0	22.68	0-2	2
	1852.5	18625	5	16-QAM	12	6	22.69	0-2	2
1852.5	18625	5	16-QAM	12	13	22.69	0-2	2	
1852.5	18625	5	16-QAM	25	0	22.93	0-2	2	
Mid	1880.0	18900	5	QPSK	1	0	24.97	0	0
	1880.0	18900	5	QPSK	1	12	24.97	0	0
	1880.0	18900	5	QPSK	1	24	25.00	0	0
	1880.0	18900	5	QPSK	12	0	23.90	0-1	1
	1880.0	18900	5	QPSK	12	6	23.91	0-1	1
	1880.0	18900	5	QPSK	12	13	23.85	0-1	1
	1880.0	18900	5	QPSK	25	0	23.84	0-1	1
	1880.0	18900	5	16-QAM	1	0	23.77	0-1	1
	1880.0	18900	5	16-QAM	1	12	23.76	0-1	1
	1880.0	18900	5	16-QAM	1	24	23.77	0-1	1
	1880.0	18900	5	16-QAM	12	0	22.93	0-2	2
	1880.0	18900	5	16-QAM	12	6	22.92	0-2	2
1880.0	18900	5	16-QAM	12	13	22.93	0-2	2	
1880.0	18900	5	16-QAM	25	0	22.82	0-2	2	
High	1907.5	19175	5	QPSK	1	0	24.98	0	0
	1907.5	19175	5	QPSK	1	12	25.00	0	0
	1907.5	19175	5	QPSK	1	24	24.99	0	0
	1907.5	19175	5	QPSK	12	0	23.99	0-1	1
	1907.5	19175	5	QPSK	12	6	24.00	0-1	1
	1907.5	19175	5	QPSK	12	13	23.95	0-1	1
	1907.5	19175	5	QPSK	25	0	23.96	0-1	1
	1907.5	19175	5	16-QAM	1	0	23.79	0-1	1
	1907.5	19175	5	16-QAM	1	12	23.96	0-1	1
	1907.5	19175	5	16-QAM	1	24	23.81	0-1	1
	1907.5	19175	5	16-QAM	12	0	22.90	0-2	2
	1907.5	19175	5	16-QAM	12	6	22.94	0-2	2
1907.5	19175	5	16-QAM	12	13	22.92	0-2	2	
1907.5	19175	5	16-QAM	25	0	23.00	0-2	2	



FCC ID: ZNFV930	 PCTEST <small>ENGINEERING LABORATORY, INC.</small>	SAR EVALUATION REPORT		Reviewed by: Quality Manager
Document S/N: OY1506161253-R2.ZNF	Test Dates: 06/17/15 - 06/23/15	DUT Type: Portable Tablet		Page 50 of 88

Table 8-35
LTE Band 2 (PCS) Conducted Powers - 3 MHz Bandwidth
Maximum Power

	Frequency [MHz]	Channel	Bandwidth [MHz]	Modulation	RB Size	RB Offset	Conducted Power [dBm]	MPR Allowed per 3GPP [dB]	MPR [dB]
Low	1851.5	18615	3	QPSK	1	0	24.90	0	0
	1851.5	18615	3	QPSK	1	7	24.90	0	0
	1851.5	18615	3	QPSK	1	14	24.93	0	0
	1851.5	18615	3	QPSK	8	0	23.87	0-1	1
	1851.5	18615	3	QPSK	8	4	23.87	0-1	1
	1851.5	18615	3	QPSK	8	7	23.86	0-1	1
	1851.5	18615	3	QPSK	15	0	23.84	0-1	1
	1851.5	18615	3	16-QAM	1	0	24.00	0-1	1
	1851.5	18615	3	16-QAM	1	7	23.98	0-1	1
	1851.5	18615	3	16-QAM	1	14	23.96	0-1	1
	1851.5	18615	3	16-QAM	8	0	22.72	0-2	2
	1851.5	18615	3	16-QAM	8	4	22.72	0-2	2
1851.5	18615	3	16-QAM	8	7	22.71	0-2	2	
1851.5	18615	3	16-QAM	15	0	22.77	0-2	2	
Mid	1880.0	18900	3	QPSK	1	0	24.97	0	0
	1880.0	18900	3	QPSK	1	7	24.96	0	0
	1880.0	18900	3	QPSK	1	14	24.99	0	0
	1880.0	18900	3	QPSK	8	0	23.82	0-1	1
	1880.0	18900	3	QPSK	8	4	23.87	0-1	1
	1880.0	18900	3	QPSK	8	7	23.86	0-1	1
	1880.0	18900	3	QPSK	15	0	23.88	0-1	1
	1880.0	18900	3	16-QAM	1	0	23.85	0-1	1
	1880.0	18900	3	16-QAM	1	7	23.81	0-1	1
	1880.0	18900	3	16-QAM	1	14	23.88	0-1	1
	1880.0	18900	3	16-QAM	8	0	22.80	0-2	2
	1880.0	18900	3	16-QAM	8	4	22.78	0-2	2
1880.0	18900	3	16-QAM	8	7	22.73	0-2	2	
1880.0	18900	3	16-QAM	15	0	22.81	0-2	2	
High	1908.5	19185	3	QPSK	1	0	24.90	0	0
	1908.5	19185	3	QPSK	1	7	25.00	0	0
	1908.5	19185	3	QPSK	1	14	24.95	0	0
	1908.5	19185	3	QPSK	8	0	23.99	0-1	1
	1908.5	19185	3	QPSK	8	4	23.94	0-1	1
	1908.5	19185	3	QPSK	8	7	24.00	0-1	1
	1908.5	19185	3	QPSK	15	0	24.00	0-1	1
	1908.5	19185	3	16-QAM	1	0	23.96	0-1	1
	1908.5	19185	3	16-QAM	1	7	23.89	0-1	1
	1908.5	19185	3	16-QAM	1	14	23.92	0-1	1
	1908.5	19185	3	16-QAM	8	0	22.81	0-2	2
	1908.5	19185	3	16-QAM	8	4	22.85	0-2	2
1908.5	19185	3	16-QAM	8	7	22.92	0-2	2	
1908.5	19185	3	16-QAM	15	0	22.97	0-2	2	



FCC ID: ZNFV930	 PCTEST <small>ENGINEERING LABORATORY, INC.</small>	SAR EVALUATION REPORT		Reviewed by: Quality Manager
Document S/N: OY1506161253-R2.ZNF	Test Dates: 06/17/15 - 06/23/15	DUT Type: Portable Tablet		Page 51 of 88

Table 8-36
LTE Band 2 (PCS) Conducted Powers -1.4 MHz Bandwidth
Maximum Power

	Frequency [MHz]	Channel	Bandwidth [MHz]	Modulation	RB Size	RB Offset	Conducted Power [dBm]	MPR Allowed per 3GPP [dB]	MPR [dB]
Low	1850.7	18607	1.4	QPSK	1	0	24.91	0	0
	1850.7	18607	1.4	QPSK	1	2	24.98	0	0
	1850.7	18607	1.4	QPSK	1	5	25.00	0	0
	1850.7	18607	1.4	QPSK	3	0	24.89	0	0
	1850.7	18607	1.4	QPSK	3	2	24.94	0	0
	1850.7	18607	1.4	QPSK	3	3	24.93	0	0
	1850.7	18607	1.4	QPSK	6	0	23.86	0-1	1
	1850.7	18607	1.4	16-QAM	1	0	23.80	0-1	1
	1850.7	18607	1.4	16-QAM	1	2	23.73	0-1	1
	1850.7	18607	1.4	16-QAM	1	5	23.83	0-1	1
	1850.7	18607	1.4	16-QAM	3	0	23.73	0-1	1
	1850.7	18607	1.4	16-QAM	3	2	23.78	0-1	1
	1850.7	18607	1.4	16-QAM	3	3	23.79	0-1	1
	1850.7	18607	1.4	16-QAM	6	0	22.78	0-2	2
Mid	1880.0	18900	1.4	QPSK	1	0	24.96	0	0
	1880.0	18900	1.4	QPSK	1	2	24.87	0	0
	1880.0	18900	1.4	QPSK	1	5	24.95	0	0
	1880.0	18900	1.4	QPSK	3	0	24.83	0	0
	1880.0	18900	1.4	QPSK	3	2	24.89	0	0
	1880.0	18900	1.4	QPSK	3	3	24.91	0	0
	1880.0	18900	1.4	QPSK	6	0	23.85	0-1	1
	1880.0	18900	1.4	16-QAM	1	0	23.90	0-1	1
	1880.0	18900	1.4	16-QAM	1	2	23.79	0-1	1
	1880.0	18900	1.4	16-QAM	1	5	23.86	0-1	1
	1880.0	18900	1.4	16-QAM	3	0	23.72	0-1	1
	1880.0	18900	1.4	16-QAM	3	2	23.68	0-1	1
	1880.0	18900	1.4	16-QAM	3	3	23.71	0-1	1
	1880.0	18900	1.4	16-QAM	6	0	22.82	0-2	2
High	1909.3	19193	1.4	QPSK	1	0	25.00	0	0
	1909.3	19193	1.4	QPSK	1	2	24.95	0	0
	1909.3	19193	1.4	QPSK	1	5	24.99	0	0
	1909.3	19193	1.4	QPSK	3	0	24.90	0	0
	1909.3	19193	1.4	QPSK	3	2	25.00	0	0
	1909.3	19193	1.4	QPSK	3	3	25.00	0	0
	1909.3	19193	1.4	QPSK	6	0	23.98	0-1	1
	1909.3	19193	1.4	16-QAM	1	0	23.82	0-1	1
	1909.3	19193	1.4	16-QAM	1	2	23.83	0-1	1
	1909.3	19193	1.4	16-QAM	1	5	23.87	0-1	1
	1909.3	19193	1.4	16-QAM	3	0	23.93	0-1	1
	1909.3	19193	1.4	16-QAM	3	2	23.94	0-1	1
	1909.3	19193	1.4	16-QAM	3	3	23.97	0-1	1
	1909.3	19193	1.4	16-QAM	6	0	22.96	0-2	2



FCC ID: ZNFV930	 PCTEST <small>ENGINEERING LABORATORY, INC.</small>	SAR EVALUATION REPORT		Reviewed by: Quality Manager
Document S/N: OY1506161253-R2.ZNF	Test Dates: 06/17/15 - 06/23/15	DUT Type: Portable Tablet		Page 52 of 88

Table 8-37
LTE Band 2 (PCS) Conducted Powers - 20 MHz Bandwidth
Reduced Power – Body at 0.0 cm

	Frequency [MHz]	Channel	Bandwidth [MHz]	Modulation	RB Size	RB Offset	Conducted Power [dBm]	MPR Allowed per 3GPP [dB]	MPR [dB]
Low	1860	18700	20	QPSK	1	0	11.56	0	0
	1860	18700	20	QPSK	1	50	12.35	0	0
	1860	18700	20	QPSK	1	99	11.94	0	0
	1860	18700	20	QPSK	50	0	11.67	0-1	0
	1860	18700	20	QPSK	50	25	12.22	0-1	0
	1860	18700	20	QPSK	50	50	12.05	0-1	0
	1860	18700	20	QPSK	100	0	11.85	0-1	0
	1860	18700	20	16QAM	1	0	11.52	0-1	0
	1860	18700	20	16QAM	1	50	12.49	0-1	0
	1860	18700	20	16QAM	1	99	12.16	0-1	0
	1860	18700	20	16QAM	50	0	11.71	0-2	0
	1860	18700	20	16QAM	50	25	11.97	0-2	0
1860	18700	20	16QAM	50	50	12.04	0-2	0	
1860	18700	20	16QAM	100	0	11.90	0-2	0	
Mid	1880.0	18900	20	QPSK	1	0	11.91	0	0
	1880.0	18900	20	QPSK	1	50	12.47	0	0
	1880.0	18900	20	QPSK	1	99	11.73	0	0
	1880.0	18900	20	QPSK	50	0	12.40	0-1	0
	1880.0	18900	20	QPSK	50	25	12.40	0-1	0
	1880.0	18900	20	QPSK	50	50	12.16	0-1	0
	1880.0	18900	20	QPSK	100	0	12.26	0-1	0
	1880.0	18900	20	16QAM	1	0	12.11	0-1	0
	1880.0	18900	20	16QAM	1	50	12.45	0-1	0
	1880.0	18900	20	16QAM	1	99	11.88	0-1	0
	1880.0	18900	20	16QAM	50	0	12.15	0-2	0
	1880.0	18900	20	16QAM	50	25	12.13	0-2	0
1880.0	18900	20	16QAM	50	50	11.92	0-2	0	
1880.0	18900	20	16QAM	100	0	12.04	0-2	0	
High	1900	19100	20	QPSK	1	0	11.56	0	0
	1900	19100	20	QPSK	1	50	12.43	0	0
	1900	19100	20	QPSK	1	99	11.90	0	0
	1900	19100	20	QPSK	50	0	12.20	0-1	0
	1900	19100	20	QPSK	50	25	12.47	0-1	0
	1900	19100	20	QPSK	50	50	12.43	0-1	0
	1900	19100	20	QPSK	100	0	12.36	0-1	0
	1900	19100	20	16QAM	1	0	11.50	0-1	0
	1900	19100	20	16QAM	1	50	12.35	0-1	0
	1900	19100	20	16QAM	1	99	11.83	0-1	0
	1900	19100	20	16QAM	50	0	11.92	0-2	0
	1900	19100	20	16QAM	50	25	12.32	0-2	0
1900	19100	20	16QAM	50	50	12.26	0-2	0	
1900	19100	20	16QAM	100	0	12.16	0-2	0	



FCC ID: ZNFV930	 PCTEST <small>ENGINEERING LABORATORY, INC.</small>	SAR EVALUATION REPORT		Reviewed by: Quality Manager
Document S/N: OY1506161253-R2.ZNF	Test Dates: 06/17/15 - 06/23/15	DUT Type: Portable Tablet		Page 53 of 88

Table 8-38
LTE Band 2 (PCS) Conducted Powers - 15 MHz Bandwidth
Reduced Power – Body at 0.0 cm

	Frequency [MHz]	Channel	Bandwidth [MHz]	Modulation	RB Size	RB Offset	Conducted Power [dBm]	MPR Allowed per 3GPP [dB]	MPR [dB]
Low	1857.5	18675	15	QPSK	1	0	11.85	0	0
	1857.5	18675	15	QPSK	1	36	12.42	0	0
	1857.5	18675	15	QPSK	1	74	12.43	0	0
	1857.5	18675	15	QPSK	36	0	11.87	0-1	0
	1857.5	18675	15	QPSK	36	18	12.37	0-1	0
	1857.5	18675	15	QPSK	36	37	12.18	0-1	0
	1857.5	18675	15	QPSK	75	0	12.00	0-1	0
	1857.5	18675	15	16QAM	1	0	11.92	0-1	0
	1857.5	18675	15	16QAM	1	36	12.42	0-1	0
	1857.5	18675	15	16QAM	1	74	12.40	0-1	0
	1857.5	18675	15	16QAM	36	0	11.64	0-2	0
	1857.5	18675	15	16QAM	36	18	12.18	0-2	0
1857.5	18675	15	16QAM	36	37	12.23	0-2	0	
1857.5	18675	15	16QAM	75	0	11.79	0-2	0	
Mid	1880.0	18900	15	QPSK	1	0	12.16	0	0
	1880.0	18900	15	QPSK	1	36	12.21	0	0
	1880.0	18900	15	QPSK	1	74	12.17	0	0
	1880.0	18900	15	QPSK	36	0	12.43	0-1	0
	1880.0	18900	15	QPSK	36	18	12.32	0-1	0
	1880.0	18900	15	QPSK	36	37	12.41	0-1	0
	1880.0	18900	15	QPSK	75	0	12.43	0-1	0
	1880.0	18900	15	16QAM	1	0	12.34	0-1	0
	1880.0	18900	15	16QAM	1	36	12.44	0-1	0
	1880.0	18900	15	16QAM	1	74	12.47	0-1	0
	1880.0	18900	15	16QAM	36	0	12.21	0-2	0
	1880.0	18900	15	16QAM	36	18	12.10	0-2	0
1880.0	18900	15	16QAM	36	37	12.19	0-2	0	
1880.0	18900	15	16QAM	75	0	12.23	0-2	0	
High	1902.5	19125	15	QPSK	1	0	12.28	0	0
	1902.5	19125	15	QPSK	1	36	12.44	0	0
	1902.5	19125	15	QPSK	1	74	12.25	0	0
	1902.5	19125	15	QPSK	36	0	12.50	0-1	0
	1902.5	19125	15	QPSK	36	18	12.49	0-1	0
	1902.5	19125	15	QPSK	36	37	12.28	0-1	0
	1902.5	19125	15	QPSK	75	0	12.45	0-1	0
	1902.5	19125	15	16QAM	1	0	12.07	0-1	0
	1902.5	19125	15	16QAM	1	36	12.29	0-1	0
	1902.5	19125	15	16QAM	1	74	12.11	0-1	0
	1902.5	19125	15	16QAM	36	0	12.22	0-2	0
	1902.5	19125	15	16QAM	36	18	12.19	0-2	0
1902.5	19125	15	16QAM	36	37	12.23	0-2	0	
1902.5	19125	15	16QAM	75	0	12.38	0-2	0	



FCC ID: ZNFV930	 PCTEST <small>ENGINEERING LABORATORY, INC.</small>	SAR EVALUATION REPORT		Reviewed by: Quality Manager
Document S/N: OY1506161253-R2.ZNF	Test Dates: 06/17/15 - 06/23/15	DUT Type: Portable Tablet		Page 54 of 88

Table 8-39
LTE Band 2 (PCS) Conducted Powers - 10 MHz Bandwidth
Reduced Power – Body at 0.0 cm

	Frequency [MHz]	Channel	Bandwidth [MHz]	Modulation	RB Size	RB Offset	Conducted Power [dBm]	MPR Allowed per 3GPP [dB]	MPR [dB]
Low	1855	18650	10	QPSK	1	0	11.61	0	0
	1855	18650	10	QPSK	1	25	12.14	0	0
	1855	18650	10	QPSK	1	49	11.97	0	0
	1855	18650	10	QPSK	25	0	11.91	0-1	0
	1855	18650	10	QPSK	25	12	12.22	0-1	0
	1855	18650	10	QPSK	25	25	12.01	0-1	0
	1855	18650	10	QPSK	50	0	11.95	0-1	0
	1855	18650	10	16QAM	1	0	11.73	0-1	0
	1855	18650	10	16QAM	1	25	12.31	0-1	0
	1855	18650	10	16QAM	1	49	12.17	0-1	0
	1855	18650	10	16QAM	25	0	11.63	0-2	0
	1855	18650	10	16QAM	25	12	12.01	0-2	0
1855	18650	10	16QAM	25	25	12.04	0-2	0	
1855	18650	10	16QAM	50	0	11.84	0-2	0	
Mid	1880.0	18900	10	QPSK	1	0	11.98	0	0
	1880.0	18900	10	QPSK	1	25	12.25	0	0
	1880.0	18900	10	QPSK	1	49	11.95	0	0
	1880.0	18900	10	QPSK	25	0	12.36	0-1	0
	1880.0	18900	10	QPSK	25	12	12.27	0-1	0
	1880.0	18900	10	QPSK	25	25	12.34	0-1	0
	1880.0	18900	10	QPSK	50	0	12.31	0-1	0
	1880.0	18900	10	16QAM	1	0	11.81	0-1	0
	1880.0	18900	10	16QAM	1	25	12.12	0-1	0
	1880.0	18900	10	16QAM	1	49	11.77	0-1	0
	1880.0	18900	10	16QAM	25	0	12.16	0-2	0
	1880.0	18900	10	16QAM	25	12	12.04	0-2	0
1880.0	18900	10	16QAM	25	25	12.09	0-2	0	
1880.0	18900	10	16QAM	50	0	12.07	0-2	0	
High	1905	19150	10	QPSK	1	0	12.06	0	0
	1905	19150	10	QPSK	1	25	12.50	0	0
	1905	19150	10	QPSK	1	49	12.12	0	0
	1905	19150	10	QPSK	25	0	12.45	0-1	0
	1905	19150	10	QPSK	25	12	12.45	0-1	0
	1905	19150	10	QPSK	25	25	12.39	0-1	0
	1905	19150	10	QPSK	50	0	12.32	0-1	0
	1905	19150	10	16QAM	1	0	12.01	0-1	0
	1905	19150	10	16QAM	1	25	12.44	0-1	0
	1905	19150	10	16QAM	1	49	12.04	0-1	0
	1905	19150	10	16QAM	25	0	12.36	0-2	0
	1905	19150	10	16QAM	25	12	12.32	0-2	0
1905	19150	10	16QAM	25	25	12.07	0-2	0	
1905	19150	10	16QAM	50	0	12.32	0-2	0	



FCC ID: ZNFV930	 PCTEST <small>ENGINEERING LABORATORY, INC.</small>	SAR EVALUATION REPORT		Reviewed by: Quality Manager
Document S/N: OY1506161253-R2.ZNF	Test Dates: 06/17/15 - 06/23/15	DUT Type: Portable Tablet		Page 55 of 88

Table 8-40
LTE Band 2 (PCS) Conducted Powers - 5 MHz Bandwidth
Reduced Power – Body at 0.0 cm

	Frequency [MHz]	Channel	Bandwidth [MHz]	Modulation	RB Size	RB Offset	Conducted Power [dBm]	MPR Allowed per 3GPP [dB]	MPR [dB]
Low	1852.5	18625	5	QPSK	1	0	11.71	0	0
	1852.5	18625	5	QPSK	1	12	11.86	0	0
	1852.5	18625	5	QPSK	1	24	11.97	0	0
	1852.5	18625	5	QPSK	12	0	11.81	0-1	0
	1852.5	18625	5	QPSK	12	6	11.93	0-1	0
	1852.5	18625	5	QPSK	12	13	11.92	0-1	0
	1852.5	18625	5	QPSK	25	0	11.91	0-1	0
	1852.5	18625	5	16-QAM	1	0	11.52	0-1	0
	1852.5	18625	5	16-QAM	1	12	12.00	0-1	0
	1852.5	18625	5	16-QAM	1	24	11.77	0-1	0
	1852.5	18625	5	16-QAM	12	0	11.57	0-2	0
	1852.5	18625	5	16-QAM	12	6	11.97	0-2	0
1852.5	18625	5	16-QAM	12	13	11.93	0-2	0	
1852.5	18625	5	16-QAM	25	0	11.70	0-2	0	
Mid	1880.0	18900	5	QPSK	1	0	12.20	0	0
	1880.0	18900	5	QPSK	1	12	12.35	0	0
	1880.0	18900	5	QPSK	1	24	12.43	0	0
	1880.0	18900	5	QPSK	12	0	12.33	0-1	0
	1880.0	18900	5	QPSK	12	6	12.31	0-1	0
	1880.0	18900	5	QPSK	12	13	12.35	0-1	0
	1880.0	18900	5	QPSK	25	0	12.36	0-1	0
	1880.0	18900	5	16-QAM	1	0	12.45	0-1	0
	1880.0	18900	5	16-QAM	1	12	12.44	0-1	0
	1880.0	18900	5	16-QAM	1	24	12.47	0-1	0
	1880.0	18900	5	16-QAM	12	0	12.12	0-2	0
	1880.0	18900	5	16-QAM	12	6	12.10	0-2	0
1880.0	18900	5	16-QAM	12	13	12.14	0-2	0	
1880.0	18900	5	16-QAM	25	0	12.08	0-2	0	
High	1907.5	19175	5	QPSK	1	0	12.17	0	0
	1907.5	19175	5	QPSK	1	12	12.19	0	0
	1907.5	19175	5	QPSK	1	24	12.22	0	0
	1907.5	19175	5	QPSK	12	0	12.34	0-1	0
	1907.5	19175	5	QPSK	12	6	12.38	0-1	0
	1907.5	19175	5	QPSK	12	13	12.30	0-1	0
	1907.5	19175	5	QPSK	25	0	12.38	0-1	0
	1907.5	19175	5	16-QAM	1	0	12.14	0-1	0
	1907.5	19175	5	16-QAM	1	12	12.47	0-1	0
	1907.5	19175	5	16-QAM	1	24	12.14	0-1	0
	1907.5	19175	5	16-QAM	12	0	12.34	0-2	0
	1907.5	19175	5	16-QAM	12	6	12.38	0-2	0
1907.5	19175	5	16-QAM	12	13	12.05	0-2	0	
1907.5	19175	5	16-QAM	25	0	12.17	0-2	0	



FCC ID: ZNFV930	 PCTEST <small>ENGINEERING LABORATORY, INC.</small>	SAR EVALUATION REPORT		Reviewed by: Quality Manager
Document S/N: OY1506161253-R2.ZNF	Test Dates: 06/17/15 - 06/23/15	DUT Type: Portable Tablet		Page 56 of 88

Table 8-41
LTE Band 2 (PCS) Conducted Powers - 3 MHz Bandwidth
Reduced Power – Body at 0.0 cm

	Frequency [MHz]	Channel	Bandwidth [MHz]	Modulation	RB Size	RB Offset	Conducted Power [dBm]	MPR Allowed per 3GPP [dB]	MPR [dB]
Low	1851.5	18615	3	QPSK	1	0	11.74	0	0
	1851.5	18615	3	QPSK	1	7	11.80	0	0
	1851.5	18615	3	QPSK	1	14	11.96	0	0
	1851.5	18615	3	QPSK	8	0	11.77	0-1	0
	1851.5	18615	3	QPSK	8	4	11.88	0-1	0
	1851.5	18615	3	QPSK	8	7	11.88	0-1	0
	1851.5	18615	3	QPSK	15	0	11.81	0-1	0
	1851.5	18615	3	16-QAM	1	0	11.83	0-1	0
	1851.5	18615	3	16-QAM	1	7	12.23	0-1	0
	1851.5	18615	3	16-QAM	1	14	12.08	0-1	0
	1851.5	18615	3	16-QAM	8	0	11.69	0-2	0
	1851.5	18615	3	16-QAM	8	4	11.81	0-2	0
1851.5	18615	3	16-QAM	8	7	11.82	0-2	0	
1851.5	18615	3	16-QAM	15	0	11.83	0-2	0	
Mid	1880.0	18900	3	QPSK	1	0	12.38	0	0
	1880.0	18900	3	QPSK	1	7	12.27	0	0
	1880.0	18900	3	QPSK	1	14	12.39	0	0
	1880.0	18900	3	QPSK	8	0	12.27	0-1	0
	1880.0	18900	3	QPSK	8	4	12.34	0-1	0
	1880.0	18900	3	QPSK	8	7	12.30	0-1	0
	1880.0	18900	3	QPSK	15	0	12.29	0-1	0
	1880.0	18900	3	16-QAM	1	0	12.33	0-1	0
	1880.0	18900	3	16-QAM	1	7	12.22	0-1	0
	1880.0	18900	3	16-QAM	1	14	12.32	0-1	0
	1880.0	18900	3	16-QAM	8	0	12.08	0-2	0
	1880.0	18900	3	16-QAM	8	4	12.11	0-2	0
1880.0	18900	3	16-QAM	8	7	12.10	0-2	0	
1880.0	18900	3	16-QAM	15	0	11.99	0-2	0	
High	1908.5	19185	3	QPSK	1	0	12.41	0	0
	1908.5	19185	3	QPSK	1	7	12.29	0	0
	1908.5	19185	3	QPSK	1	14	12.31	0	0
	1908.5	19185	3	QPSK	8	0	12.31	0-1	0
	1908.5	19185	3	QPSK	8	4	12.31	0-1	0
	1908.5	19185	3	QPSK	8	7	12.26	0-1	0
	1908.5	19185	3	QPSK	15	0	12.29	0-1	0
	1908.5	19185	3	16-QAM	1	0	12.24	0-1	0
	1908.5	19185	3	16-QAM	1	7	12.40	0-1	0
	1908.5	19185	3	16-QAM	1	14	12.09	0-1	0
	1908.5	19185	3	16-QAM	8	0	12.16	0-2	0
	1908.5	19185	3	16-QAM	8	4	12.18	0-2	0
1908.5	19185	3	16-QAM	8	7	12.10	0-2	0	
1908.5	19185	3	16-QAM	15	0	12.26	0-2	0	





FCC ID: ZNFV930	 PCTEST <small>ENGINEERING LABORATORY, INC.</small>	SAR EVALUATION REPORT		Reviewed by: Quality Manager
Document S/N: OY1506161253-R2.ZNF	Test Dates: 06/17/15 - 06/23/15	DUT Type: Portable Tablet		Page 57 of 88

Table 8-42
LTE Band 2 (PCS) Conducted Powers – 1.4 MHz Bandwidth
Reduced Power – Body at 0.0 cm

	Frequency [MHz]	Channel	Bandwidth [MHz]	Modulation	RB Size	RB Offset	Conducted Power [dBm]	MPR Allowed per 3GPP [dB]	MPR [dB]
Low	1850.7	18607	1.4	QPSK	1	0	11.90	0	0
	1850.7	18607	1.4	QPSK	1	2	11.85	0	0
	1850.7	18607	1.4	QPSK	1	5	12.01	0	0
	1850.7	18607	1.4	QPSK	3	0	11.66	0	0
	1850.7	18607	1.4	QPSK	3	2	11.76	0	0
	1850.7	18607	1.4	QPSK	3	3	11.70	0	0
	1850.7	18607	1.4	QPSK	6	0	11.75	0-1	0
	1850.7	18607	1.4	16-QAM	1	0	11.78	0-1	0
	1850.7	18607	1.4	16-QAM	1	2	11.96	0-1	0
	1850.7	18607	1.4	16-QAM	1	5	11.94	0-1	0
	1850.7	18607	1.4	16-QAM	3	0	11.88	0-1	0
	1850.7	18607	1.4	16-QAM	3	2	12.01	0-1	0
	1850.7	18607	1.4	16-QAM	3	3	11.96	0-1	0
1850.7	18607	1.4	16-QAM	6	0	11.86	0-2	0	
Mid	1880.0	18900	1.4	QPSK	1	0	12.09	0	0
	1880.0	18900	1.4	QPSK	1	2	12.29	0	0
	1880.0	18900	1.4	QPSK	1	5	12.11	0	0
	1880.0	18900	1.4	QPSK	3	0	12.29	0	0
	1880.0	18900	1.4	QPSK	3	2	12.36	0	0
	1880.0	18900	1.4	QPSK	3	3	12.32	0	0
	1880.0	18900	1.4	QPSK	6	0	12.33	0-1	0
	1880.0	18900	1.4	16-QAM	1	0	11.97	0-1	0
	1880.0	18900	1.4	16-QAM	1	2	12.17	0-1	0
	1880.0	18900	1.4	16-QAM	1	5	12.04	0-1	0
	1880.0	18900	1.4	16-QAM	3	0	12.16	0-1	0
	1880.0	18900	1.4	16-QAM	3	2	12.22	0-1	0
	1880.0	18900	1.4	16-QAM	3	3	12.16	0-1	0
1880.0	18900	1.4	16-QAM	6	0	12.04	0-2	0	
High	1909.3	19193	1.4	QPSK	1	0	12.33	0	0
	1909.3	19193	1.4	QPSK	1	2	12.25	0	0
	1909.3	19193	1.4	QPSK	1	5	12.31	0	0
	1909.3	19193	1.4	QPSK	3	0	12.26	0	0
	1909.3	19193	1.4	QPSK	3	2	12.30	0	0
	1909.3	19193	1.4	QPSK	3	3	12.24	0	0
	1909.3	19193	1.4	QPSK	6	0	12.26	0-1	0
	1909.3	19193	1.4	16-QAM	1	0	12.41	0-1	0
	1909.3	19193	1.4	16-QAM	1	2	12.50	0-1	0
	1909.3	19193	1.4	16-QAM	1	5	12.41	0-1	0
	1909.3	19193	1.4	16-QAM	3	0	12.23	0-1	0
	1909.3	19193	1.4	16-QAM	3	2	12.26	0-1	0
	1909.3	19193	1.4	16-QAM	3	3	12.18	0-1	0
1909.3	19193	1.4	16-QAM	6	0	12.22	0-2	0	

FCC ID: ZNFV930	 PCTEST <small>ENGINEERING LABORATORY, INC.</small>	SAR EVALUATION REPORT		Reviewed by: Quality Manager
Document S/N: OY1506161253-R2.ZNF	Test Dates: 06/17/15 - 06/23/15	DUT Type: Portable Tablet		Page 58 of 88

8.2.5

LTE Band 7 (PCS)

Table 8-43
LTE Band 7 (PCS) Conducted Powers - 20 MHz Bandwidth
Maximum Power

	Frequency [MHz]	Channel	Bandwidth [MHz]	Modulation	RB Size	RB Offset	Conducted Power [dBm]	MPR Allowed per 3GPP [dB]	MPR [dB]
Low	2510	20850	20	QPSK	1	0	22.89	0	0
	2510	20850	20	QPSK	1	50	22.75	0	0
	2510	20850	20	QPSK	1	99	22.88	0	0
	2510	20850	20	QPSK	50	0	21.85	0-1	1
	2510	20850	20	QPSK	50	25	21.86	0-1	1
	2510	20850	20	QPSK	50	50	21.79	0-1	1
	2510	20850	20	QPSK	100	0	21.70	0-1	1
	2510	20850	20	16QAM	1	0	21.86	0-1	1
	2510	20850	20	16QAM	1	50	21.81	0-1	1
	2510	20850	20	16QAM	1	99	21.78	0-1	1
	2510	20850	20	16QAM	50	0	20.85	0-2	2
	2510	20850	20	16QAM	50	25	20.89	0-2	2
	2510	20850	20	16QAM	50	50	20.91	0-2	2
	2510	20850	20	16QAM	100	0	20.75	0-2	2
Mid	2535.0	21100	20	QPSK	1	0	22.99	0	0
	2535.0	21100	20	QPSK	1	50	22.86	0	0
	2535.0	21100	20	QPSK	1	99	22.91	0	0
	2535.0	21100	20	QPSK	50	0	21.91	0-1	1
	2535.0	21100	20	QPSK	50	25	21.86	0-1	1
	2535.0	21100	20	QPSK	50	50	21.81	0-1	1
	2535.0	21100	20	QPSK	100	0	21.76	0-1	1
	2535.0	21100	20	16QAM	1	0	21.75	0-1	1
	2535.0	21100	20	16QAM	1	50	21.84	0-1	1
	2535.0	21100	20	16QAM	1	99	21.90	0-1	1
	2535.0	21100	20	16QAM	50	0	20.67	0-2	2
	2535.0	21100	20	16QAM	50	25	20.84	0-2	2
	2535.0	21100	20	16QAM	50	50	20.77	0-2	2
	2535.0	21100	20	16QAM	100	0	20.70	0-2	2
High	2560	21350	20	QPSK	1	0	22.90	0	0
	2560	21350	20	QPSK	1	50	22.95	0	0
	2560	21350	20	QPSK	1	99	22.93	0	0
	2560	21350	20	QPSK	50	0	21.85	0-1	1
	2560	21350	20	QPSK	50	25	21.89	0-1	1
	2560	21350	20	QPSK	50	50	21.90	0-1	1
	2560	21350	20	QPSK	100	0	21.80	0-1	1
	2560	21350	20	16QAM	1	0	21.88	0-1	1
	2560	21350	20	16QAM	1	50	21.78	0-1	1
	2560	21350	20	16QAM	1	99	21.77	0-1	1
	2560	21350	20	16QAM	50	0	20.86	0-2	2
	2560	21350	20	16QAM	50	25	20.71	0-2	2
	2560	21350	20	16QAM	50	50	20.89	0-2	2
	2560	21350	20	16QAM	100	0	20.75	0-2	2



FCC ID: ZNFV930	 PCTEST ENGINEERING LABORATORY, INC.	SAR EVALUATION REPORT		Reviewed by: Quality Manager
Document S/N: OY1506161253-R2.ZNF	Test Dates: 06/17/15 - 06/23/15	DUT Type: Portable Tablet	Page 59 of 88	

Table 8-44
LTE Band 7 (PCS) Conducted Powers - 15 MHz Bandwidth
Maximum Power

	Frequency [MHz]	Channel	Bandwidth [MHz]	Modulation	RB Size	RB Offset	Conducted Power [dBm]	MPR Allowed per 3GPP [dB]	MPR [dB]
Low	2507.5	20825	15	QPSK	1	0	22.91	0	0
	2507.5	20825	15	QPSK	1	36	22.58	0	0
	2507.5	20825	15	QPSK	1	74	22.62	0	0
	2507.5	20825	15	QPSK	36	0	21.69	0-1	1
	2507.5	20825	15	QPSK	36	18	21.66	0-1	1
	2507.5	20825	15	QPSK	36	37	21.74	0-1	1
	2507.5	20825	15	QPSK	75	0	21.71	0-1	1
	2507.5	20825	15	16QAM	1	0	21.76	0-1	1
	2507.5	20825	15	16QAM	1	36	21.55	0-1	1
	2507.5	20825	15	16QAM	1	74	21.56	0-1	1
	2507.5	20825	15	16QAM	36	0	20.66	0-2	2
	2507.5	20825	15	16QAM	36	18	20.63	0-2	2
2507.5	20825	15	16QAM	36	37	20.71	0-2	2	
2507.5	20825	15	16QAM	75	0	20.72	0-2	2	
Mid	2535.0	21100	15	QPSK	1	0	22.76	0	0
	2535.0	21100	15	QPSK	1	36	22.67	0	0
	2535.0	21100	15	QPSK	1	74	22.64	0	0
	2535.0	21100	15	QPSK	36	0	21.70	0-1	1
	2535.0	21100	15	QPSK	36	18	21.63	0-1	1
	2535.0	21100	15	QPSK	36	37	21.59	0-1	1
	2535.0	21100	15	QPSK	75	0	21.74	0-1	1
	2535.0	21100	15	16QAM	1	0	21.70	0-1	1
	2535.0	21100	15	16QAM	1	36	21.49	0-1	1
	2535.0	21100	15	16QAM	1	74	21.52	0-1	1
	2535.0	21100	15	16QAM	36	0	20.82	0-2	2
	2535.0	21100	15	16QAM	36	18	20.71	0-2	2
2535.0	21100	15	16QAM	36	37	20.69	0-2	2	
2535.0	21100	15	16QAM	75	0	20.75	0-2	2	
High	2562.5	21375	15	QPSK	1	0	22.64	0	0
	2562.5	21375	15	QPSK	1	36	22.59	0	0
	2562.5	21375	15	QPSK	1	74	22.84	0	0
	2562.5	21375	15	QPSK	36	0	21.75	0-1	1
	2562.5	21375	15	QPSK	36	18	21.68	0-1	1
	2562.5	21375	15	QPSK	36	37	21.83	0-1	1
	2562.5	21375	15	QPSK	75	0	21.70	0-1	1
	2562.5	21375	15	16QAM	1	0	21.76	0-1	1
	2562.5	21375	15	16QAM	1	36	21.58	0-1	1
	2562.5	21375	15	16QAM	1	74	21.78	0-1	1
	2562.5	21375	15	16QAM	36	0	20.69	0-2	2
	2562.5	21375	15	16QAM	36	18	20.61	0-2	2
2562.5	21375	15	16QAM	36	37	20.80	0-2	2	
2562.5	21375	15	16QAM	75	0	20.78	0-2	2	



FCC ID: ZNFV930	 PCTEST <small>ENGINEERING LABORATORY, INC.</small>	SAR EVALUATION REPORT		Reviewed by: Quality Manager
Document S/N: OY1506161253-R2.ZNF	Test Dates: 06/17/15 - 06/23/15	DUT Type: Portable Tablet		Page 60 of 88

Table 8-45
LTE Band 7 (PCS) Conducted Powers - 10 MHz Bandwidth
Maximum Power

	Frequency [MHz]	Channel	Bandwidth [MHz]	Modulation	RB Size	RB Offset	Conducted Power [dBm]	MPR Allowed per 3GPP [dB]	MPR [dB]
Low	2505	20800	10	QPSK	1	0	22.92	0	0
	2505	20800	10	QPSK	1	25	22.64	0	0
	2505	20800	10	QPSK	1	49	22.67	0	0
	2505	20800	10	QPSK	25	0	21.78	0-1	1
	2505	20800	10	QPSK	25	12	21.68	0-1	1
	2505	20800	10	QPSK	25	25	21.59	0-1	1
	2505	20800	10	QPSK	50	0	21.65	0-1	1
	2505	20800	10	16QAM	1	0	21.73	0-1	1
	2505	20800	10	16QAM	1	25	21.55	0-1	1
	2505	20800	10	16QAM	1	49	21.57	0-1	1
	2505	20800	10	16QAM	25	0	20.72	0-2	2
	2505	20800	10	16QAM	25	12	20.64	0-2	2
2505	20800	10	16QAM	25	25	20.62	0-2	2	
2505	20800	10	16QAM	50	0	20.69	0-2	2	
Mid	2535.0	21100	10	QPSK	1	0	22.61	0	0
	2535.0	21100	10	QPSK	1	25	22.62	0	0
	2535.0	21100	10	QPSK	1	49	22.50	0	0
	2535.0	21100	10	QPSK	25	0	21.68	0-1	1
	2535.0	21100	10	QPSK	25	12	21.57	0-1	1
	2535.0	21100	10	QPSK	25	25	21.56	0-1	1
	2535.0	21100	10	QPSK	50	0	21.71	0-1	1
	2535.0	21100	10	16QAM	1	0	21.52	0-1	1
	2535.0	21100	10	16QAM	1	25	21.40	0-1	1
	2535.0	21100	10	16QAM	1	49	21.35	0-1	1
	2535.0	21100	10	16QAM	25	0	20.84	0-2	2
	2535.0	21100	10	16QAM	25	12	20.68	0-2	2
2535.0	21100	10	16QAM	25	25	20.67	0-2	2	
2535.0	21100	10	16QAM	50	0	20.72	0-2	2	
High	2565	21400	10	QPSK	1	0	22.71	0	0
	2565	21400	10	QPSK	1	25	22.81	0	0
	2565	21400	10	QPSK	1	49	22.84	0	0
	2565	21400	10	QPSK	25	0	21.64	0-1	1
	2565	21400	10	QPSK	25	12	21.82	0-1	1
	2565	21400	10	QPSK	25	25	21.79	0-1	1
	2565	21400	10	QPSK	50	0	21.78	0-1	1
	2565	21400	10	16QAM	1	0	21.85	0-1	1
	2565	21400	10	16QAM	1	25	21.81	0-1	1
	2565	21400	10	16QAM	1	49	21.84	0-1	1
	2565	21400	10	16QAM	25	0	20.61	0-2	2
	2565	21400	10	16QAM	25	12	20.82	0-2	2
2565	21400	10	16QAM	25	25	20.81	0-2	2	
2565	21400	10	16QAM	50	0	20.75	0-2	2	



FCC ID: ZNFV930	 PCTEST <small>ENGINEERING LABORATORY, INC.</small>	SAR EVALUATION REPORT		Reviewed by: Quality Manager
Document S/N: OY1506161253-R2.ZNF	Test Dates: 06/17/15 - 06/23/15	DUT Type: Portable Tablet		Page 61 of 88

Table 8-46
LTE Band 7 (PCS) Conducted Powers - 5 MHz Bandwidth
Maximum Power

	Frequency [MHz]	Channel	Bandwidth [MHz]	Modulation	RB Size	RB Offset	Conducted Power [dBm]	MPR Allowed per 3GPP [dB]	MPR [dB]
Low	2502.5	20775	5	QPSK	1	0	22.91	0	0
	2502.5	20775	5	QPSK	1	12	22.80	0	0
	2502.5	20775	5	QPSK	1	24	22.73	0	0
	2502.5	20775	5	QPSK	12	0	21.75	0-1	1
	2502.5	20775	5	QPSK	12	6	21.71	0-1	1
	2502.5	20775	5	QPSK	12	13	21.66	0-1	1
	2502.5	20775	5	QPSK	25	0	21.76	0-1	1
	2502.5	20775	5	16-QAM	1	0	21.68	0-1	1
	2502.5	20775	5	16-QAM	1	12	21.61	0-1	1
	2502.5	20775	5	16-QAM	1	24	21.58	0-1	1
	2502.5	20775	5	16-QAM	12	0	20.62	0-2	2
	2502.5	20775	5	16-QAM	12	6	20.60	0-2	2
2502.5	20775	5	16-QAM	12	13	20.57	0-2	2	
2502.5	20775	5	16-QAM	25	0	20.72	0-2	2	
Mid	2535.0	21100	5	QPSK	1	0	22.51	0	0
	2535.0	21100	5	QPSK	1	12	22.44	0	0
	2535.0	21100	5	QPSK	1	24	22.47	0	0
	2535.0	21100	5	QPSK	12	0	21.59	0-1	1
	2535.0	21100	5	QPSK	12	6	21.58	0-1	1
	2535.0	21100	5	QPSK	12	13	21.63	0-1	1
	2535.0	21100	5	QPSK	25	0	21.57	0-1	1
	2535.0	21100	5	16-QAM	1	0	21.40	0-1	1
	2535.0	21100	5	16-QAM	1	12	21.30	0-1	1
	2535.0	21100	5	16-QAM	1	24	21.37	0-1	1
	2535.0	21100	5	16-QAM	12	0	20.71	0-2	2
	2535.0	21100	5	16-QAM	12	6	20.71	0-2	2
2535.0	21100	5	16-QAM	12	13	20.68	0-2	2	
2535.0	21100	5	16-QAM	25	0	20.78	0-2	2	
High	2567.5	21425	5	QPSK	1	0	22.95	0	0
	2567.5	21425	5	QPSK	1	12	22.93	0	0
	2567.5	21425	5	QPSK	1	24	22.90	0	0
	2567.5	21425	5	QPSK	12	0	21.79	0-1	1
	2567.5	21425	5	QPSK	12	6	21.74	0-1	1
	2567.5	21425	5	QPSK	12	13	21.73	0-1	1
	2567.5	21425	5	QPSK	25	0	21.75	0-1	1
	2567.5	21425	5	16-QAM	1	0	21.81	0-1	1
	2567.5	21425	5	16-QAM	1	12	21.68	0-1	1
	2567.5	21425	5	16-QAM	1	24	21.73	0-1	1
	2567.5	21425	5	16-QAM	12	0	20.78	0-2	2
	2567.5	21425	5	16-QAM	12	6	20.75	0-2	2
2567.5	21425	5	16-QAM	12	13	20.73	0-2	2	
2567.5	21425	5	16-QAM	25	0	20.75	0-2	2	



FCC ID: ZNFV930	 PCTEST <small>ENGINEERING LABORATORY, INC.</small>	SAR EVALUATION REPORT		Reviewed by: Quality Manager
Document S/N: OY1506161253-R2.ZNF	Test Dates: 06/17/15 - 06/23/15	DUT Type: Portable Tablet		Page 62 of 88

Table 8-47
LTE Band 7 (PCS) Conducted Powers - 20 MHz Bandwidth
Reduced Power – Body at 0.0 cm

	Frequency [MHz]	Channel	Bandwidth [MHz]	Modulation	RB Size	RB Offset	Conducted Power [dBm]	MPR Allowed per 3GPP [dB]	MPR [dB]
Low	2510	20850	20	QPSK	1	0	11.53	0	0
	2510	20850	20	QPSK	1	50	11.99	0	0
	2510	20850	20	QPSK	1	99	11.66	0	0
	2510	20850	20	QPSK	50	0	12.00	0-1	0
	2510	20850	20	QPSK	50	25	12.18	0-1	0
	2510	20850	20	QPSK	50	50	12.08	0-1	0
	2510	20850	20	QPSK	100	0	12.05	0-1	0
	2510	20850	20	16QAM	1	0	11.55	0-1	0
	2510	20850	20	16QAM	1	50	12.50	0-1	0
	2510	20850	20	16QAM	1	99	11.86	0-1	0
	2510	20850	20	16QAM	50	0	11.76	0-2	0
	2510	20850	20	16QAM	50	25	12.12	0-2	0
2510	20850	20	16QAM	50	50	12.04	0-2	0	
2510	20850	20	16QAM	100	0	11.80	0-2	0	
Mid	2535.0	21100	20	QPSK	1	0	11.77	0	0
	2535.0	21100	20	QPSK	1	50	12.22	0	0
	2535.0	21100	20	QPSK	1	99	11.61	0	0
	2535.0	21100	20	QPSK	50	0	11.94	0-1	0
	2535.0	21100	20	QPSK	50	25	12.14	0-1	0
	2535.0	21100	20	QPSK	50	50	12.16	0-1	0
	2535.0	21100	20	QPSK	100	0	12.06	0-1	0
	2535.0	21100	20	16QAM	1	0	11.99	0-1	0
	2535.0	21100	20	16QAM	1	50	12.42	0-1	0
	2535.0	21100	20	16QAM	1	99	12.15	0-1	0
	2535.0	21100	20	16QAM	50	0	11.61	0-2	0
	2535.0	21100	20	16QAM	50	25	11.80	0-2	0
2535.0	21100	20	16QAM	50	50	11.72	0-2	0	
2535.0	21100	20	16QAM	100	0	11.72	0-2	0	
High	2560	21350	20	QPSK	1	0	11.75	0	0
	2560	21350	20	QPSK	1	50	12.44	0	0
	2560	21350	20	QPSK	1	99	11.70	0	0
	2560	21350	20	QPSK	50	0	12.28	0-1	0
	2560	21350	20	QPSK	50	25	12.43	0-1	0
	2560	21350	20	QPSK	50	50	11.94	0-1	0
	2560	21350	20	QPSK	100	0	11.94	0-1	0
	2560	21350	20	16QAM	1	0	11.59	0-1	0
	2560	21350	20	16QAM	1	50	12.27	0-1	0
	2560	21350	20	16QAM	1	99	11.62	0-1	0
	2560	21350	20	16QAM	50	0	11.95	0-2	0
	2560	21350	20	16QAM	50	25	12.08	0-2	0
2560	21350	20	16QAM	50	50	11.93	0-2	0	
2560	21350	20	16QAM	100	0	11.91	0-2	0	



FCC ID: ZNFV930	 PCTEST <small>ENGINEERING LABORATORY, INC.</small>	SAR EVALUATION REPORT		Reviewed by: Quality Manager
Document S/N: OY1506161253-R2.ZNF	Test Dates: 06/17/15 - 06/23/15	DUT Type: Portable Tablet		Page 63 of 88

Table 8-48
LTE Band 7 (PCS) Conducted Powers - 15 MHz Bandwidth
Reduced Power – Body at 0.0 cm

	Frequency [MHz]	Channel	Bandwidth [MHz]	Modulation	RB Size	RB Offset	Conducted Power [dBm]	MPR Allowed per 3GPP [dB]	MPR [dB]
Low	2507.5	20825	15	QPSK	1	0	11.78	0	0
	2507.5	20825	15	QPSK	1	36	12.04	0	0
	2507.5	20825	15	QPSK	1	74	12.12	0	0
	2507.5	20825	15	QPSK	36	0	12.24	0-1	0
	2507.5	20825	15	QPSK	36	18	12.09	0-1	0
	2507.5	20825	15	QPSK	36	37	12.13	0-1	0
	2507.5	20825	15	QPSK	75	0	12.09	0-1	0
	2507.5	20825	15	16QAM	1	0	11.83	0-1	0
	2507.5	20825	15	16QAM	1	36	12.07	0-1	0
	2507.5	20825	15	16QAM	1	74	12.16	0-1	0
	2507.5	20825	15	16QAM	36	0	11.89	0-2	0
	2507.5	20825	15	16QAM	36	18	11.78	0-2	0
2507.5	20825	15	16QAM	36	37	11.83	0-2	0	
2507.5	20825	15	16QAM	75	0	11.75	0-2	0	
Mid	2535.0	21100	15	QPSK	1	0	12.00	0	0
	2535.0	21100	15	QPSK	1	36	11.99	0	0
	2535.0	21100	15	QPSK	1	74	11.75	0	0
	2535.0	21100	15	QPSK	36	0	11.96	0-1	0
	2535.0	21100	15	QPSK	36	18	12.06	0-1	0
	2535.0	21100	15	QPSK	36	37	12.14	0-1	0
	2535.0	21100	15	QPSK	75	0	12.08	0-1	0
	2535.0	21100	15	16QAM	1	0	11.75	0-1	0
	2535.0	21100	15	16QAM	1	36	11.73	0-1	0
	2535.0	21100	15	16QAM	1	74	11.88	0-1	0
	2535.0	21100	15	16QAM	36	0	11.58	0-2	0
	2535.0	21100	15	16QAM	36	18	11.67	0-2	0
2535.0	21100	15	16QAM	36	37	11.75	0-2	0	
2535.0	21100	15	16QAM	75	0	11.82	0-2	0	
High	2562.5	21375	15	QPSK	1	0	11.99	0	0
	2562.5	21375	15	QPSK	1	36	12.34	0	0
	2562.5	21375	15	QPSK	1	74	11.84	0	0
	2562.5	21375	15	QPSK	36	0	11.98	0-1	0
	2562.5	21375	15	QPSK	36	18	12.23	0-1	0
	2562.5	21375	15	QPSK	36	37	11.87	0-1	0
	2562.5	21375	15	QPSK	75	0	11.95	0-1	0
	2562.5	21375	15	16QAM	1	0	11.88	0-1	0
	2562.5	21375	15	16QAM	1	36	12.09	0-1	0
	2562.5	21375	15	16QAM	1	74	11.65	0-1	0
	2562.5	21375	15	16QAM	36	0	12.03	0-2	0
	2562.5	21375	15	16QAM	36	18	11.99	0-2	0
2562.5	21375	15	16QAM	36	37	11.68	0-2	0	
2562.5	21375	15	16QAM	75	0	11.85	0-2	0	



FCC ID: ZNFV930	 PCTEST <small>ENGINEERING LABORATORY, INC.</small>	SAR EVALUATION REPORT		Reviewed by: Quality Manager
Document S/N: OY1506161253-R2.ZNF	Test Dates: 06/17/15 - 06/23/15	DUT Type: Portable Tablet		Page 64 of 88

Table 8-49
LTE Band 7 (PCS) Conducted Powers - 10 MHz Bandwidth
Reduced Power – Body at 0.0 cm

	Frequency [MHz]	Channel	Bandwidth [MHz]	Modulation	RB Size	RB Offset	Conducted Power [dBm]	MPR Allowed per 3GPP [dB]	MPR [dB]
Low	2505	20800	10	QPSK	1	0	11.68	0	0
	2505	20800	10	QPSK	1	25	12.07	0	0
	2505	20800	10	QPSK	1	49	12.06	0	0
	2505	20800	10	QPSK	25	0	12.25	0-1	0
	2505	20800	10	QPSK	25	12	12.19	0-1	0
	2505	20800	10	QPSK	25	25	12.22	0-1	0
	2505	20800	10	QPSK	50	0	12.26	0-1	0
	2505	20800	10	16QAM	1	0	11.70	0-1	0
	2505	20800	10	16QAM	1	25	11.99	0-1	0
	2505	20800	10	16QAM	1	49	12.08	0-1	0
	2505	20800	10	16QAM	25	0	11.90	0-2	0
	2505	20800	10	16QAM	25	12	11.88	0-2	0
2505	20800	10	16QAM	25	25	11.93	0-2	0	
2505	20800	10	16QAM	50	0	11.93	0-2	0	
Mid	2535.0	21100	10	QPSK	1	0	11.99	0	0
	2535.0	21100	10	QPSK	1	25	12.08	0	0
	2535.0	21100	10	QPSK	1	49	12.06	0	0
	2535.0	21100	10	QPSK	25	0	12.02	0-1	0
	2535.0	21100	10	QPSK	25	12	12.13	0-1	0
	2535.0	21100	10	QPSK	25	25	12.12	0-1	0
	2535.0	21100	10	QPSK	50	0	12.15	0-1	0
	2535.0	21100	10	16QAM	1	0	11.82	0-1	0
	2535.0	21100	10	16QAM	1	25	11.84	0-1	0
	2535.0	21100	10	16QAM	1	49	11.85	0-1	0
	2535.0	21100	10	16QAM	25	0	11.69	0-2	0
	2535.0	21100	10	16QAM	25	12	11.79	0-2	0
2535.0	21100	10	16QAM	25	25	11.88	0-2	0	
2535.0	21100	10	16QAM	50	0	11.86	0-2	0	
High	2565	21400	10	QPSK	1	0	11.88	0	0
	2565	21400	10	QPSK	1	25	11.78	0	0
	2565	21400	10	QPSK	1	49	11.64	0	0
	2565	21400	10	QPSK	25	0	12.07	0-1	0
	2565	21400	10	QPSK	25	12	12.09	0-1	0
	2565	21400	10	QPSK	25	25	11.97	0-1	0
	2565	21400	10	QPSK	50	0	12.02	0-1	0
	2565	21400	10	16QAM	1	0	11.79	0-1	0
	2565	21400	10	16QAM	1	25	11.96	0-1	0
	2565	21400	10	16QAM	1	49	11.53	0-1	0
	2565	21400	10	16QAM	25	0	12.02	0-2	0
	2565	21400	10	16QAM	25	12	12.03	0-2	0
2565	21400	10	16QAM	25	25	11.70	0-2	0	
2565	21400	10	16QAM	50	0	11.78	0-2	0	





FCC ID: ZNFV930	 PCTEST <small>ENGINEERING LABORATORY, INC.</small>	SAR EVALUATION REPORT		Reviewed by: Quality Manager
Document S/N: OY1506161253-R2.ZNF	Test Dates: 06/17/15 - 06/23/15	DUT Type: Portable Tablet		Page 65 of 88

Table 8-50
LTE Band 7 (PCS) Conducted Powers - 5 MHz Bandwidth
Reduced Power – Body at 0.0 cm

	Frequency [MHz]	Channel	Bandwidth [MHz]	Modulation	RB Size	RB Offset	Conducted Power [dBm]	MPR Allowed per 3GPP [dB]	MPR [dB]
Low	2502.5	20775	5	QPSK	1	0	11.75	0	0
	2502.5	20775	5	QPSK	1	12	12.10	0	0
	2502.5	20775	5	QPSK	1	24	12.12	0	0
	2502.5	20775	5	QPSK	12	0	12.27	0-1	0
	2502.5	20775	5	QPSK	12	6	12.15	0-1	0
	2502.5	20775	5	QPSK	12	13	12.23	0-1	0
	2502.5	20775	5	QPSK	25	0	12.25	0-1	0
	2502.5	20775	5	16-QAM	1	0	12.18	0-1	0
	2502.5	20775	5	16-QAM	1	12	12.25	0-1	0
	2502.5	20775	5	16-QAM	1	24	12.22	0-1	0
	2502.5	20775	5	16-QAM	12	0	11.95	0-2	0
	2502.5	20775	5	16-QAM	12	6	11.87	0-2	0
2502.5	20775	5	16-QAM	12	13	11.91	0-2	0	
2502.5	20775	5	16-QAM	25	0	11.92	0-2	0	
Mid	2535.0	21100	5	QPSK	1	0	12.17	0	0
	2535.0	21100	5	QPSK	1	12	12.17	0	0
	2535.0	21100	5	QPSK	1	24	12.21	0	0
	2535.0	21100	5	QPSK	12	0	12.12	0-1	0
	2535.0	21100	5	QPSK	12	6	12.18	0-1	0
	2535.0	21100	5	QPSK	12	13	12.15	0-1	0
	2535.0	21100	5	QPSK	25	0	12.17	0-1	0
	2535.0	21100	5	16-QAM	1	0	12.19	0-1	0
	2535.0	21100	5	16-QAM	1	12	12.16	0-1	0
	2535.0	21100	5	16-QAM	1	24	12.20	0-1	0
	2535.0	21100	5	16-QAM	12	0	11.81	0-2	0
	2535.0	21100	5	16-QAM	12	6	11.88	0-2	0
2535.0	21100	5	16-QAM	12	13	11.89	0-2	0	
2535.0	21100	5	16-QAM	25	0	11.86	0-2	0	
High	2567.5	21425	5	QPSK	1	0	11.98	0	0
	2567.5	21425	5	QPSK	1	12	11.97	0	0
	2567.5	21425	5	QPSK	1	24	11.80	0	0
	2567.5	21425	5	QPSK	12	0	12.03	0-1	0
	2567.5	21425	5	QPSK	12	6	12.05	0-1	0
	2567.5	21425	5	QPSK	12	13	11.95	0-1	0
	2567.5	21425	5	QPSK	25	0	11.97	0-1	0
	2567.5	21425	5	16-QAM	1	0	11.99	0-1	0
	2567.5	21425	5	16-QAM	1	12	12.20	0-1	0
	2567.5	21425	5	16-QAM	1	24	11.82	0-1	0
	2567.5	21425	5	16-QAM	12	0	11.76	0-2	0
	2567.5	21425	5	16-QAM	12	6	11.98	0-2	0
2567.5	21425	5	16-QAM	12	13	11.67	0-2	0	
2567.5	21425	5	16-QAM	25	0	11.76	0-2	0	

FCC ID: ZNFV930	 PCTEST <small>ENGINEERING LABORATORY, INC.</small>	SAR EVALUATION REPORT		Reviewed by: Quality Manager
Document S/N: OY1506161253-R2.ZNF	Test Dates: 06/17/15 - 06/23/15	DUT Type: Portable Tablet		Page 66 of 88

8.2.6 LTE Carrier Aggregation Conducted Powers

Table 8-51
LTE Carrier Aggregation Conducted Powers
Maximum Power

PCC						SCC				Power	
PCC Band	PCC Bandwidth [MHz]	PCC (UL) Frequency [MHz]	PCC (UL) Channel	PCC UL# RB	PCC UL RB Offset	SCC Band	SCC Bandwidth [MHz]	SCC (DL) Frequency [MHz]	SCC (DL) Channel	LTE Rel 10 Tx.Power (dBm)	LTE Rel. 8 Tx.Power (dBm)
LTE B4	10	1715	20000	1	49	LTE B17	10	740	5790	24.73	25.00
LTE B4	10	1715	20000	1	49	LTE B29	10	722.5	9715	24.95	25.00
LTE B2	10	1880	18900	1	49	LTE B29	10	722.5	9715	24.82	25.00
LTE B2	10	1880	18900	1	49	LTE B17	10	740	5790	24.91	25.00
LTE B12	10	707.5	23095	1	49	LTE B4	10	2132.5	2175	24.50	24.50
LTE B4	10	1715	20000	1	49	LTE B12	10	737.5	5095	24.52	25.00
LTE B17	10	710	23790	1	49	LTE B2	10	1960	900	24.29	24.50

Table 8-52
LTE Carrier Aggregation Conducted Powers
Reduced Power

PCC							SCC				Power	
PCC Band	PCC Bandwidth [MHz]	Modulation	PCC (UL) Frequency [MHz]	PCC (UL) Channel	PCC UL# RB	PCC UL RB Offset	SCC Band	SCC Bandwidth [MHz]	SCC (DL) Frequency [MHz]	SCC (DL) Channel	LTE Rel 10 Tx.Power (dBm)	LTE Rel. 8 Tx.Power (dBm)
LTE B4	5	QPSK	1752.5	20375	1	0	LTE B17	10	740	5790	12.46	12.36
LTE B4	5	QPSK	1752.5	20375	1	0	LTE B29	10	722.5	9715	12.45	12.36
LTE B2	10	QPSK	1905	19150	1	25	LTE B29	10	722.5	9715	12.49	12.50
LTE B2	10	QPSK	1905	19150	1	25	LTE B17	10	740	5790	12.44	12.50
LTE B12	5	16-QAM	707.5	23095	1	0	LTE B4	10	2132.5	2175	18.26	18.50
LTE B4	5	QPSK	1752.2	20375	1	0	LTE B12	10	737.5	5095	12.23	12.36
LTE B17	5	16-QAM	710	23790	1	0	LTE B2	10	1960	900	18.41	18.50

Notes:

1. The device does not support all Rel. 10 Carrier Aggregation features due to modem chipset limitation.
2. The device only supports downlink Carrier Aggregation. Uplink Carrier Aggregation is not supported. Power measurements were performed with two DL carriers for the Release 8 configuration that had the highest output power (across all bandwidths, channels and RB Configurations) for each band
3. All control and acknowledge data is sent on uplink channels that operate identical to release 8 specifications.
4. This device supports both LTE Band 12 and LTE Band 17. Since the supported frequency span for LTE Band 17 falls completely within the supported frequency span for LTE band 12, LTE Band 17 has same or lower target power as LTE Band 12, and both LTE bands share the same transmission path, Some LTE CA SAR combinations were only assessed for LTE Band 12 as PCC.

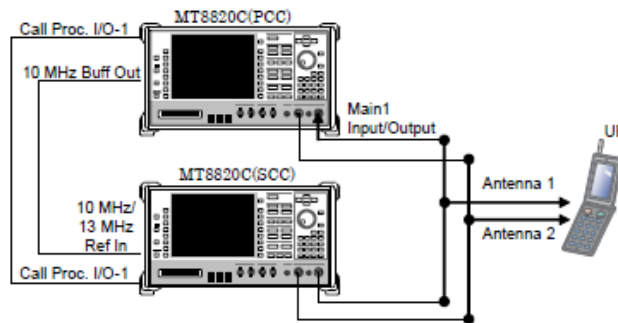



Figure 8-2
Power Measurement Setup

FCC ID: ZNFV930	 SAR EVALUATION REPORT 		Reviewed by: Quality Manager
Document S/N: OY1506161253-R2.ZNF	Test Dates: 06/17/15 - 06/23/15	DUT Type: Portable Tablet	Page 67 of 88



8.3 WLAN Conducted Powers

Table 8-53
2.4 GHz Average RF Power

Freq [MHz]	Channel	2.4GHz Conducted Power [dBm]		
		802.11b	802.11g	802.11n
2412	1	10.44	8.08	8.02
2437	6	10.71	8.04	8.21
2462	11	10.79	8.35	8.42

Table 8-54
5 GHz (20 MHz Bandwidth) Average RF Power

Freq [MHz]	Channel	5GHz (20MHz) Conducted Power [dBm]		
		802.11a	802.11n	802.11ac
5180	36	7.68	7.49	7.65
5200	40	7.52	7.55	7.55
5220	44	7.42	7.40	7.45
5240	48	7.50	7.36	7.38
5260	52	7.24	7.41	7.41
5280	56	7.31	7.30	7.33
5300	60	7.41	7.29	7.38
5320	64	7.27	7.51	7.49
5500	100	7.74	7.83	7.86
5580	116	7.65	7.58	7.73
5660	132	7.51	7.61	7.65
5700	140	7.51	7.47	7.56
5745	149	7.34	7.44	7.51
5785	157	7.28	7.33	7.42
5825	165	7.33	7.31	7.39

FCC ID: ZNFV930	 PCTEST ENGINEERING LABORATORY, INC.	SAR EVALUATION REPORT	 LG	Reviewed by: Quality Manager
Document S/N: OY1506161253-R2.ZNF	Test Dates: 06/17/15 - 06/23/15	DUT Type: Portable Tablet	Page 68 of 88	

Justification for test configurations for WLAN per KDB Publication 248227 D01v02r01:

- Power measurements were performed for the transmission mode configuration with the highest maximum output power specified for production units.
- For transmission modes with the same maximum output power specification, powers were measured for the largest channel bandwidth, lowest order modulation and lowest data rate.
- For transmission modes with identical maximum specified output power, channel bandwidth, modulation and data rates, power measurements were required for all identical configurations.
- For each transmission mode configuration, powers were measured for the highest and lowest channels; and at the mid-band channel(s) when there were at least 3 channels supported. For configurations with multiple mid-band channels, due to an even number of channels, both channels were measured.
- The bolded data rate and channel above were tested for SAR.

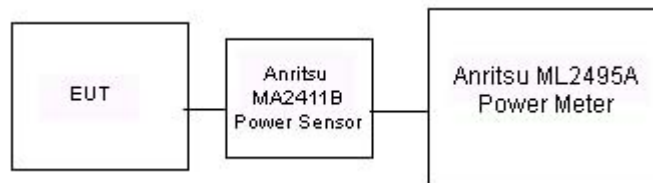

Figure 8-3
Power Measurement Setup for Bandwidths < 50 MHz

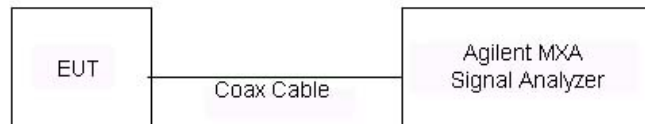



Figure 8-4
Power Measurement Setup for Bandwidths > 50 MHz

FCC ID: ZNFV930	 SAR EVALUATION REPORT 		Reviewed by: Quality Manager
Document S/N: OY1506161253-R2.ZNF	Test Dates: 06/17/15 - 06/23/15	DUT Type: Portable Tablet	Page 69 of 88



9 SYSTEM VERIFICATION

9.1 Tissue Verification

**Table 9-1
Measured Tissue Properties**

Calibrated for Tests Performed on:	Tissue Type	Tissue Temp During Calibration (C°)	Measured Frequency (MHz)	Measured Conductivity, σ (S/m)	Measured Dielectric Constant, ϵ	TARGET Conductivity, σ (S/m)	TARGET Dielectric Constant, ϵ	% dev σ	% dev ϵ
06/23/2015	750B	22.0	700	0.917	55.286	0.959	55.726	-4.38%	-0.79%
			710	0.928	55.146	0.960	55.687	-3.33%	-0.97%
			720	0.938	55.052	0.961	55.648	-2.39%	-1.07%
			725	0.945	54.982	0.961	55.629	-1.66%	-1.16%
			740	0.959	54.746	0.963	55.570	-0.42%	-1.48%
			755	0.968	54.582	0.964	55.512	0.41%	-1.68%
06/19/2015	835B	22.5	820	0.983	53.108	0.969	55.258	1.44%	-3.89%
			835	0.997	52.981	0.970	55.200	2.78%	-4.02%
			850	1.012	52.834	0.988	55.154	2.43%	-4.21%
06/18/2015	1750B	22.6	1710	1.427	52.377	1.463	53.537	-2.46%	-2.17%
			1750	1.470	52.276	1.488	53.432	-1.21%	-2.16%
			1790	1.509	52.080	1.514	53.326	-0.33%	-2.34%
06/17/2015	1900B	22.8	1850	1.496	51.379	1.520	53.300	-1.58%	-3.60%
			1880	1.530	51.272	1.520	53.300	0.66%	-3.80%
			1910	1.562	51.154	1.520	53.300	2.76%	-4.03%
06/19/2015	2450B	23.5	2400	1.878	51.750	1.902	52.767	-1.26%	-1.93%
			2450	1.944	51.620	1.950	52.700	-0.31%	-2.05%
			2500	2.010	51.430	2.021	52.636	-0.54%	-2.29%
			2550	2.083	51.201	2.092	52.573	-0.43%	-2.61%
			2600	2.153	51.030	2.163	52.509	-0.46%	-2.82%
06/22/2015	5200B-5800B	21.4	5280	5.457	47.411	5.393	48.906	1.19%	-3.06%
			5300	5.507	47.205	5.416	48.879	1.68%	-3.42%
			5500	5.752	46.978	5.650	48.607	1.81%	-3.35%
			5745	6.084	46.648	5.936	48.275	2.49%	-3.37%
			5800	6.151	46.492	6.000	48.200	2.52%	-3.54%

The above measured tissue parameters were used in the DASY software. The DASY software was used to perform interpolation to determine the dielectric parameters at the SAR test device frequencies (per KDB Publication 865664 and IEEE 1528-2013 6.6.1.2). The tissue parameters listed in the SAR test plots may slightly differ from the table above due to significant digit rounding in the software.

FCC ID: ZNFV930	 PCTEST ENGINEERING LABORATORY, INC.	SAR EVALUATION REPORT		Reviewed by: Quality Manager
Document S/N: OY1506161253-R2.ZNF	Test Dates: 06/17/15 - 06/23/15	DUT Type: Portable Tablet		Page 70 of 88

9.2 Test System Verification

Prior to SAR assessment, the system is verified to $\pm 10\%$ of the SAR measurement on the reference dipole at the time of calibration by the calibration facility. Full system validation status and result summary can be found in Appendix E.

Table 9-2
System Verification Results

System Verification TARGET & MEASURED												
SAR System #	Tissue Frequency (MHz)	Tissue Type	Date:	Amb. Temp (°C)	Liquid Temp (°C)	Input Power (W)	Dipole SN	Probe SN	Measured SAR _{1g} (W/kg)	1 W Target SAR _{1g} (W/kg)	1 W Normalized SAR _{1g} (W/kg)	Deviation _{1g} (%)
A	750	BODY	06/23/2015	23.8	22.0	0.200	1046	3331	1.770	8.290	8.850	6.76%
A	835	BODY	06/19/2015	23.5	22.5	0.200	4d119	3331	1.970	9.200	9.850	7.07%
B	1750	BODY	06/18/2015	23.1	22.6	0.100	1008	3334	3.970	38.000	39.700	4.47%
A	1900	BODY	06/17/2015	24.3	22.8	0.100	5d148	3331	4.250	40.200	42.500	5.72%
B	2450	BODY	06/19/2015	22.3	23.5	0.100	882	3334	5.250	50.700	52.500	3.55%
B	2600	BODY	06/19/2015	22.3	23.5	0.100	1004	3334	5.280	56.200	52.800	-6.05%
A	5300	BODY	06/22/2015	23.8	21.4	0.050	1191	3914	3.840	79.900	76.800	-3.88%
A	5500	BODY	06/22/2015	23.8	21.4	0.050	1191	3914	4.020	83.100	80.400	-3.25%
A	5800	BODY	06/22/2015	23.8	21.4	0.050	1191	3914	3.720	78.000	74.400	-4.62%

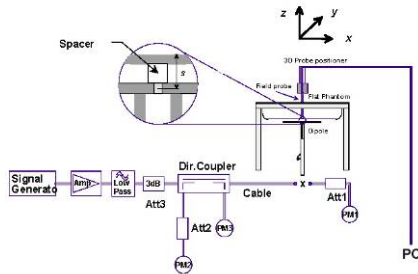

Figure 9-1
System Verification Setup Diagram



Figure 9-2
System Verification Setup Photo

FCC ID: ZNFV930	PCTEST ENGINEERING LABORATORY, INC.	SAR EVALUATION REPORT	LG	Reviewed by: Quality Manager
Document S/N: OY1506161253-R2.ZNF	Test Dates: 06/17/15 - 06/23/15	DUT Type: Portable Tablet		Page 71 of 88

© 2015 PCTEST Engineering Laboratory, Inc.

REV 16.0 M
06/12/2015

(c) 2015 PCTEST Engineering Laboratory, Inc. All rights reserved. Unless otherwise specified, no part of this report may be reproduced or utilized in any part, form or by any means, electronic or mechanical, including photocopying and microfilm, without permission in writing from PCTEST Engineering Laboratory, Inc. If you have any questions about this international copyright or have an enquiry about obtaining additional rights to this report or assembly of contents thereof, please contact info@pctestlab.com.

10 SAR DATA SUMMARY



10.1 Standalone Body SAR Data

**Table 10-1
UMTS Body SAR Data**

MEASUREMENT RESULTS														
FREQUENCY		Mode	Service	Maximum Allowed Power [dBm]	Conducted Power [dBm]	Power Drift [dB]	Spacing	Device Serial Number	Duty Cycle	Side	SAR (1g)	Scaling Factor	Scaled SAR (1g)	Plot #
MHz	Ch.										(W/kg)		(W/kg)	
836.60	4183	UMTS 850	RMC	24.0	23.97	0.04	16 mm	02231	1:1	back	0.410	1.007	0.413	
836.60	4183	UMTS 850	RMC	24.0	23.97	-0.05	19 mm	02231	1:1	top	0.281	1.007	0.283	
836.60	4183	UMTS 850	RMC	24.0	23.97	-0.11	0 mm	02231	1:1	left	0.077	1.007	0.078	
836.60	4183	UMTS 850	RMC	18.5	18.40	0.01	0 mm	02256	1:1	back	0.464	1.023	0.475	
836.60	4183	UMTS 850	RMC	18.5	18.40	-0.02	0 mm	02256	1:1	top	0.536	1.023	0.548	A1
1880.00	9400	UMTS 1900	RMC	24.0	24.00	-0.01	12 mm	02231	1:1	back	0.598	1.000	0.598	A2
1880.00	9400	UMTS 1900	RMC	24.0	24.00	0.01	14 mm	02231	1:1	right	0.489	1.000	0.489	
1880.00	9400	UMTS 1900	RMC	12.5	12.40	0.02	0 mm	02256	1:1	back	0.457	1.023	0.468	
1880.00	9400	UMTS 1900	RMC	12.5	12.40	0.16	0 mm	02256	1:1	right	0.300	1.023	0.307	
ANSI / IEEE C95.1 1992 - SAFETY LIMIT Spatial Peak Uncontrolled Exposure/General Population								Body 1.6 W/kg (mW/g) averaged over 1 gram						

**Table 10-2
LTE Band 12 Body SAR Data**

MEASUREMENT RESULTS																			
FREQUENCY		Mode	Bandwidth [MHz]	Maximum Allowed Power [dBm]	Conducted Power [dBm]	Power Drift [dB]	MPR [dB]	Device Serial Number	Modulation	RB Size	RB Offset	Spacing	Side	Duty Cycle	SAR (1g)	Scaling Factor	Scaled SAR (1g)	Plot #	
MHz	Ch.														(W/kg)		(W/kg)		
707.50	23095	Mid	LTE Band 12	10	24.5	24.50	0.02	0	02231	QPSK	1	49	16 mm	back	1:1	0.399	1.000	0.399	
707.50	23095	Mid	LTE Band 12	10	23.5	23.33	0.00	1	02231	QPSK	25	0	16 mm	back	1:1	0.308	1.040	0.320	
707.50	23095	Mid	LTE Band 12	10	24.5	24.50	-0.01	0	02231	QPSK	1	49	19 mm	top	1:1	0.271	1.000	0.271	
707.50	23095	Mid	LTE Band 12	10	23.5	23.33	-0.01	1	02231	QPSK	25	0	19 mm	top	1:1	0.213	1.040	0.222	
707.50	23095	Mid	LTE Band 12	10	24.5	24.50	0.09	0	02231	QPSK	1	49	0 mm	left	1:1	0.082	1.000	0.082	
707.50	23095	Mid	LTE Band 12	10	23.5	23.33	0.11	1	02231	QPSK	25	0	0 mm	left	1:1	0.064	1.040	0.067	
707.50	23095	Mid	LTE Band 12	10	18.5	18.23	0.00	0	02249	QPSK	1	0	0 mm	back	1:1	0.607	1.064	0.646	A3
707.50	23095	Mid	LTE Band 12	10	18.5	18.28	-0.05	0	02249	QPSK	25	25	0 mm	back	1:1	0.571	1.052	0.601	
707.50	23095	Mid	LTE Band 12	10	18.5	18.23	0.05	0	02249	QPSK	1	0	0 mm	top	1:1	0.524	1.064	0.558	
707.50	23095	Mid	LTE Band 12	10	18.5	18.28	0.06	0	02249	QPSK	25	25	0 mm	top	1:1	0.510	1.052	0.537	
ANSI / IEEE C95.1 1992 - SAFETY LIMIT Spatial Peak Uncontrolled Exposure/General Population								Body 1.6 W/kg (mW/g) averaged over 1 gram											

FCC ID: ZNFV930	 PCTEST ENGINEERING LABORATORY, INC.	SAR EVALUATION REPORT	 LG	Reviewed by: Quality Manager
Document S/N: OY1506161253-R2.ZNF	Test Dates: 06/17/15 - 06/23/15	DUT Type: Portable Tablet		Page 72 of 88

**Table 10-3
LTE Band 5 (Cell) Body SAR Data**



MEASUREMENT RESULTS																			
FREQUENCY		Mode	Bandwidth [MHz]	Maximum Allowed Power [dBm]	Conducted Power [dBm]	Power Drift [dB]	MPR [dB]	Device Serial Number	Modulation	RB Size	RB Offset	Spacing	Side	Duty Cycle	SAR (1g)	Scaling Factor	Scaled SAR (1g)	Plot #	
MHz	Ch.														(W/kg)		(W/kg)		
836.50	20525	Mid	LTE Band 5 (Cell)	10	24.5	24.50	0.08	0	02231	QPSK	1	49	16 mm	back	1:1	0.498	1.000	0.498	
836.50	20525	Mid	LTE Band 5 (Cell)	10	23.5	23.37	0.07	1	02231	QPSK	25	12	16 mm	back	1:1	0.359	1.030	0.370	
836.50	20525	Mid	LTE Band 5 (Cell)	10	24.5	24.50	0.04	0	02231	QPSK	1	49	19 mm	top	1:1	0.411	1.000	0.411	
836.50	20525	Mid	LTE Band 5 (Cell)	10	23.5	23.37	0.07	1	02231	QPSK	25	12	19 mm	top	1:1	0.280	1.030	0.288	
836.50	20525	Mid	LTE Band 5 (Cell)	10	24.5	24.50	-0.02	0	02231	QPSK	1	49	0 mm	left	1:1	0.086	1.000	0.086	
836.50	20525	Mid	LTE Band 5 (Cell)	10	23.5	23.37	0.00	1	02231	QPSK	25	12	0 mm	left	1:1	0.069	1.030	0.071	
836.50	20525	Mid	LTE Band 5 (Cell)	10	18.5	18.38	0.02	0	02256	QPSK	1	49	0 mm	back	1:1	0.614	1.028	0.631	
836.50	20525	Mid	LTE Band 5 (Cell)	10	18.5	18.27	0.03	0	02256	QPSK	25	25	0 mm	back	1:1	0.629	1.054	0.663	
836.50	20525	Mid	LTE Band 5 (Cell)	10	18.5	18.38	-0.01	0	02256	QPSK	1	49	0 mm	top	1:1	0.689	1.028	0.708	
836.50	20525	Mid	LTE Band 5 (Cell)	10	18.5	18.27	0.04	0	02256	QPSK	25	25	0 mm	top	1:1	0.710	1.054	0.748	A4
ANSI / IEEE C95.1 1992 - SAFETY LIMIT Spatial Peak Uncontrolled Exposure/General Population								Body 1.6 W/kg (mW/g) averaged over 1 gram											

**Table 10-4
LTE Band 4 (AWS) Body SAR Data**

MEASUREMENT RESULTS																			
FREQUENCY		Mode	Bandwidth [MHz]	Maximum Allowed Power [dBm]	Conducted Power [dBm]	Power Drift [dB]	MPR [dB]	Device Serial Number	Modulation	RB Size	RB Offset	Spacing	Side	Duty Cycle	SAR (1g)	Scaling Factor	Scaled SAR (1g)	Plot #	
MHz	Ch.														(W/kg)		(W/kg)		
1732.50	20175	Mid	LTE Band 4 (AWS)	20	25.0	25.00	-0.04	0	02223	QPSK	1	0	12 mm	back	1:1	0.571	1.000	0.571	
1732.50	20175	Mid	LTE Band 4 (AWS)	20	24.0	23.86	0.01	1	02223	QPSK	50	0	12 mm	back	1:1	0.430	1.033	0.444	
1732.50	20175	Mid	LTE Band 4 (AWS)	20	25.0	25.00	0.02	0	02223	QPSK	1	0	14 mm	right	1:1	0.576	1.000	0.576	A5
1732.50	20175	Mid	LTE Band 4 (AWS)	20	24.0	23.86	-0.14	1	02223	QPSK	50	0	14 mm	right	1:1	0.428	1.033	0.442	
1732.50	20175	Mid	LTE Band 4 (AWS)	20	12.5	12.38	0.06	0	02256	QPSK	1	50	0 mm	back	1:1	0.572	1.028	0.588	
1732.50	20175	Mid	LTE Band 4 (AWS)	20	12.5	12.26	0.12	0	02256	QPSK	50	25	0 mm	back	1:1	0.575	1.057	0.608	
1732.50	20175	Mid	LTE Band 4 (AWS)	20	12.5	12.38	-0.06	0	02256	QPSK	1	50	0 mm	right	1:1	0.259	1.028	0.266	
1732.50	20175	Mid	LTE Band 4 (AWS)	20	12.5	12.26	-0.06	0	02256	QPSK	50	25	0 mm	right	1:1	0.252	1.057	0.266	
ANSI / IEEE C95.1 1992 - SAFETY LIMIT Spatial Peak Uncontrolled Exposure/General Population								Body 1.6 W/kg (mW/g) averaged over 1 gram											

**Table 10-5
LTE Band 2 (PCS) Body SAR Data**

MEASUREMENT RESULTS																			
FREQUENCY		Mode	Bandwidth [MHz]	Maximum Allowed Power [dBm]	Conducted Power [dBm]	Power Drift [dB]	MPR [dB]	Device Serial Number	Modulation	RB Size	RB Offset	Spacing	Side	Duty Cycle	SAR (1g)	Scaling Factor	Scaled SAR (1g)	Plot #	
MHz	Ch.														(W/kg)		(W/kg)		
1880.00	18900	Mid	LTE Band 2 (PCS)	20	25.0	25.00	-0.01	0	02231	QPSK	1	0	12 mm	back	1:1	0.651	1.000	0.651	
1860.00	18700	Low	LTE Band 2 (PCS)	20	24.0	23.97	-0.02	1	02231	QPSK	50	0	12 mm	back	1:1	0.724	1.007	0.729	A6
1880.00	18900	Mid	LTE Band 2 (PCS)	20	25.0	25.00	0.19	0	02231	QPSK	1	0	14 mm	right	1:1	0.506	1.000	0.506	
1860.00	18700	Low	LTE Band 2 (PCS)	20	24.0	23.97	0.04	1	02231	QPSK	50	0	14 mm	right	1:1	0.542	1.007	0.546	
1880.00	18900	Mid	LTE Band 2 (PCS)	20	12.5	12.47	0.00	0	02256	QPSK	1	50	0 mm	back	1:1	0.524	1.007	0.528	
1900.00	19100	High	LTE Band 2 (PCS)	20	12.5	12.47	-0.04	0	02256	QPSK	50	25	0 mm	back	1:1	0.477	1.007	0.480	
1880.00	18900	Mid	LTE Band 2 (PCS)	20	12.5	12.47	0.02	0	02256	QPSK	1	50	0 mm	right	1:1	0.317	1.007	0.319	
1900.00	19100	High	LTE Band 2 (PCS)	20	12.5	12.47	0.02	0	02256	QPSK	50	25	0 mm	right	1:1	0.303	1.007	0.305	
ANSI / IEEE C95.1 1992 - SAFETY LIMIT Spatial Peak Uncontrolled Exposure/General Population								Body 1.6 W/kg (mW/g) averaged over 1 gram											

FCC ID: ZNFV930		SAR EVALUATION REPORT		Reviewed by: Quality Manager
Document S/N: OY1506161253-R2.ZNF	Test Dates: 06/17/15 - 06/23/15	DUT Type: Portable Tablet		Page 73 of 88

**Table 10-6
LTE Band 7 Body SAR Data**

MEASUREMENT RESULTS																		
FREQUENCY		Mode	Bandwidth [MHz]	Maximum Allowed Power [dBm]	Conducted Power [dBm]	Power Drift [dB]	MPR [dB]	Device Serial Number	Modulation	RB Size	RB Offset	Spacing	Side	Duty Cycle	SAR (1g) (W/kg)	Scaling Factor	Scaled SAR (1g) (W/kg)	Plot #
MHz	Ch.																	
2535.00	21100	Mid	20	23.0	22.99	-0.03	0	02223	QPSK	1	0	16 mm	back	1:1	0.393	1.002	0.394	
2535.00	21100	Mid	20	22.0	21.91	0.02	1	02223	QPSK	50	0	16 mm	back	1:1	0.312	1.021	0.319	
2535.00	21100	Mid	20	23.0	22.99	0.00	0	02223	QPSK	1	0	19 mm	top	1:1	0.213	1.002	0.213	
2535.00	21100	Mid	20	22.0	21.91	0.01	1	02223	QPSK	50	0	19 mm	top	1:1	0.168	1.021	0.172	
2535.00	21100	Mid	20	23.0	22.99	0.08	0	02223	QPSK	1	0	0 mm	left	1:1	0.173	1.002	0.173	
2535.00	21100	Mid	20	22.0	21.91	0.06	1	02223	QPSK	50	0	0 mm	left	1:1	0.132	1.021	0.135	
2560.00	21350	High	20	12.5	12.44	-0.05	0	02249	QPSK	1	50	0 mm	back	1:1	0.721	1.014	0.731	
2560.00	21350	High	20	12.5	12.43	-0.06	0	02249	QPSK	50	25	0 mm	back	1:1	0.721	1.016	0.733	A7
2560.00	21350	High	20	12.5	12.44	0.03	0	02249	QPSK	1	50	0 mm	top	1:1	0.350	1.014	0.355	
2560.00	21350	High	20	12.5	12.43	0.02	0	02249	QPSK	50	25	0 mm	top	1:1	0.343	1.016	0.348	
ANSI / IEEE C95.1 1992 - SAFETY LIMIT										Body								
Spatial Peak										1.6 W/kg (mW/g)								
Uncontrolled Exposure/General Population										averaged over 1 gram								



**Table 10-7
WLAN Body SAR Data**

MEASUREMENT RESULTS																	
FREQUENCY		Mode	Service	Bandwidth [MHz]	Maximum Allowed Power [dBm]	Conducted Power [dBm]	Power Drift [dB]	Spacing	Device Serial Number	Data Rate (Mbps)	Side	Duty Cycle (%)	SAR (1g) (W/kg)	Scaling Factor (Power)	Scaling Factor (Duty Cycle)	Scaled SAR (1g) (W/kg)	Plot #
MHz	Ch.																
2462	11	802.11b	DSSS	22	11.0	10.79	-0.01	0 mm	02264	1	back	99.5	0.366	1.050	1.005	0.386	A8
2462	11	802.11b	DSSS	22	11.0	10.79	0.05	0 mm	02264	1	top	99.5	0.248	1.050	1.005	0.261	
2462	11	802.11b	DSSS	22	11.0	10.79	-0.02	0 mm	02264	1	right	99.5	0.230	1.050	1.005	0.243	
5300	60	802.11a	OFDM	20	8.0	7.41	0.16	0 mm	02264	6	back	96.0	0.295	1.146	1.042	0.352	
5300	60	802.11a	OFDM	20	8.0	7.41	0.01	0 mm	02264	6	top	96.0	0.579	1.146	1.042	0.692	A9
5300	60	802.11a	OFDM	20	8.0	7.41	0.21	0 mm	02264	6	right	96.0	0.116	1.146	1.042	0.139	
5500	100	802.11a	OFDM	20	8.0	7.74	0.05	0 mm	02264	6	back	96.0	0.141	1.062	1.042	0.156	
5500	100	802.11a	OFDM	20	8.0	7.74	0.02	0 mm	02264	6	top	96.0	0.337	1.062	1.042	0.373	
5500	100	802.11a	OFDM	20	8.0	7.74	0.04	0 mm	02264	6	right	96.0	0.064	1.062	1.042	0.071	
5745	149	802.11a	OFDM	20	8.0	7.34	0.01	0 mm	02264	6	back	96.0	0.049	1.164	1.042	0.059	
5745	149	802.11a	OFDM	20	8.0	7.34	-0.18	0 mm	02264	6	top	96.0	0.021	1.164	1.042	0.025	
5745	149	802.11a	OFDM	20	8.0	7.34	0.01	0 mm	02264	6	right	96.0	0.032	1.164	1.042	0.039	
ANSI / IEEE C95.1 1992 - SAFETY LIMIT										Body							
Spatial Peak										1.6 W/kg (mW/g)							
Uncontrolled Exposure/General Population										averaged over 1 gram							

10.2 SAR Test Notes

General Notes:

1. The test data reported are the worst-case SAR values according to test procedures specified in FCC KDB Publication 616217 D04v01r01 and FCC KDB Publication 447498 D01v05.
2. Batteries are fully charged at the beginning of the SAR measurements.
3. Liquid tissue depth was at least 15.0 cm for all frequencies.
4. The manufacturer has confirmed that the device(s) tested have the same physical, mechanical and thermal characteristics and are within operational tolerances expected for production units.
5. SAR results were scaled to the maximum allowed power to demonstrate compliance per FCC KDB Publication 447498 D01v05.
6. Per FCC KDB 865664 D01v01, variability SAR tests were not required since the measured SAR results for all frequency bands were not greater than 0.8 W/kg. Please see Section 12 for variability analysis.

FCC ID: ZNFV930		SAR EVALUATION REPORT		Reviewed by: Quality Manager
Document S/N: OY1506161253-R2.ZNF	Test Dates: 06/17/15 - 06/23/15	DUT Type: Portable Tablet		Page 74 of 88

- Per FCC KDB 616217 D04 Section 4.3, SAR tests are required for the back surface and edges of the tablet with the tablet touching the phantom. The SAR Exclusion Threshold in FCC KDB 447498 D01v05 was applied to determine SAR test exclusion for adjacent edge configurations. SAR tests were required for top left and right edges for the main antenna, and were required for top and right edges for the WLAN/BT antenna.

UMTS Notes:



- UMTS mode in was tested under RMC 12.2 kbps with HSPA Inactive per KDB Publication 941225 D01v03. AMR and HSPA SAR was not required per the 3G Test Reduction Procedure in KDB Publication 941225 D01v03.
- Per FCC KDB Publication 447498 D01v05, if the reported (scaled) SAR measured at the middle channel or highest output power channel for each test configuration is ≤ 0.8 W/kg then testing at the other channels is not required for such test configuration(s). When the maximum output power variation across the required test channels is $> \frac{1}{2}$ dB, instead of the middle channel, the highest output power channel was used.

LTE Notes:

- LTE Considerations: LTE test configurations are determined according to SAR Evaluation Considerations for LTE Devices in FCC KDB Publication 941225 D05v02r03. The general test procedures used for testing can be found in Section 7.5.4.
- MPR is permanently implemented for this device by the manufacturer. The specific manufacturer target MPR is indicated alongside the SAR results. MPR is enabled for this device, according to 3GPP TS36.101 Section 6.2.3 – 6.2.5 under Table 6.2.3-1.
- A-MPR was disabled for all SAR tests by setting NS=01 on the base station simulator. SAR tests were performed with the same number of RB and RB offsets transmitting on all TTI frames (maximum TTI).
- Per KDB Publication 941225 D05Av01r01, SAR for LTE CA operations was not needed since the maximum average output power in LTE CA mode was not >0.25 dB higher than the maximum output power when downlink carrier aggregation was inactive.

WLAN Notes:

- Justification for test configurations for WLAN per KDB Publication 248227 D01v02r01 for 2.4 GHz WIFI operations, the highest measured maximum output power channel for DSSS was selected for SAR measurement. SAR for OFDM modes (2.4 GHz 802.11g/n) was not required due to the maximum allowed powers and the highest reported DSSS SAR. See Section 7.6.4 for more information.
- Justification for test configurations for WLAN per KDB Publication 248227 D01v02r01 for 5 GHz WIFI operations, the initial test configuration was selected according to the transmission mode with the highest maximum allowed powers. Other transmission modes were not investigated since the highest reported SAR for initial test configuration adjusted by the ratio of maximum output powers is less than 1.2 W/kg. See Section 7.6 for more information.
- When the maximum reported 1g averaged SAR is ≤ 0.8 W/kg, SAR testing on additional channels was not required. Otherwise, SAR for the next highest output power channel was required until the reported SAR result was ≤ 1.20 W/kg or all test channels were measured.
- The device was configured to transmit continuously at the required data rate, channel bandwidth and signal modulation, using the highest transmission duty factor supported by the test mode tools. The reported SAR was scaled to the 100% transmission duty factor to determine compliance. Procedures used to measure the duty factor are identical to that in the associated EMC test reports.

FCC ID: ZNFV930	 PCTEST ENGINEERING LABORATORY, INC.	SAR EVALUATION REPORT	 LG	Reviewed by: Quality Manager
Document S/N: OY1506161253-R2.ZNF	Test Dates: 06/17/15 - 06/23/15	DUT Type: Portable Tablet		Page 75 of 88

11 FCC MULTI-TX AND ANTENNA SAR CONSIDERATIONS

11.1 Introduction

The following procedures adopted from FCC KDB Publication 447498 D01v05r02 are applicable to devices with built-in unlicensed transmitters such as 802.11 and Bluetooth devices which may simultaneously transmit with the licensed transmitter.

11.2 Simultaneous Transmission Procedures

This device contains transmitters that may operate simultaneously. Therefore simultaneous transmission analysis is required. Per FCC KDB 447498 D01v05 IV.C.1.iii and IEEE 1528-2013 Section 6.3.4.1.2, simultaneous transmission SAR test exclusion may be applied when the sum of the 1-g SAR for all the simultaneous transmitting antennas in a specific physical test configuration is ≤ 1.6 W/kg. The different test positions in an exposure condition may be considered collectively to determine SAR test exclusion according to the sum of 1-g or 10-g SAR.

When standalone SAR is not required to be measured, per FCC KDB 447498 D01v05 4.3.2 2), the following equation must be used to estimate the standalone 1g SAR for simultaneous transmission assessment involving that transmitter.



$$\text{Estimated SAR} = \frac{\sqrt{f(\text{GHz})}}{7.5} * \frac{(\text{Max Power of channel, mW})}{\text{Min. Separation Distance, mm}}$$

**Table 11-1
Estimated SAR**

Mode	Frequency	Maximum Allowed Power	Separation Distance (Body)	Estimated SAR (Body)
	[MHz]	[dBm]	[mm]	[W/kg]
Bluetooth Back, Top Right Touching*	2480	9.50	5	0.378
Bluetooth Back	2480	9.50	12	0.157
Bluetooth Back	2480	9.50	16	0.118
Bluetooth Top	2480	9.50	19	0.099
Bluetooth Right	2480	9.50	14	0.135

Notes:

1. Per FCC KDB Publication 447498 D01v05, the maximum power of the channel was rounded to the nearest mW before calculation.
2. (*) – Per FCC KDB Publication 447498, when the antenna separation distance is < 5 mm, a distance of 5 mm is applied to determine estimated SAR.
3. When the antenna separation distance was > 50 mm, an estimated SAR of 0.4 W/kg was used to determine the simultaneous transmission SAR exclusion, for configurations excluded per FCC KDB Publication 447498 D01v05.

FCC ID: ZNFV930	 SAR EVALUATION REPORT 		Reviewed by: Quality Manager
Document S/N: OY1506161253-R2.ZNF	Test Dates: 06/17/15 - 06/23/15	DUT Type: Portable Tablet	Page 76 of 88



11.3 Body SAR Simultaneous Transmission Analysis

Table 11-2
Simultaneous Transmission Scenario with 2.4 GHz WLAN (Body at 0.0 cm)

Simult Tx	Configuration	UMTS 850 SAR (W/kg)	2.4 GHz WLAN SAR (W/kg)	Σ SAR (W/kg)	Simult Tx	Configuration	UMTS 1900 SAR (W/kg)	2.4 GHz WLAN SAR (W/kg)	Σ SAR (W/kg)
Body SAR	Back	0.475	0.386	0.861	Body SAR	Back	0.468	0.386	0.854
	Top	0.548	0.261	0.809		Top	0.400	0.261	0.661
	Bottom	0.400	0.400	0.800		Bottom	0.400	0.400	0.800
	Right	0.400	0.243	0.643		Right	0.307	0.243	0.550
	Left	0.078	0.400	0.478		Left	0.400	0.400	0.800
Simult Tx	Configuration	LTE Band 12 SAR (W/kg)	2.4 GHz WLAN SAR (W/kg)	Σ SAR (W/kg)	Simult Tx	Configuration	LTE Band 5 (Cell) SAR (W/kg)	2.4 GHz WLAN SAR (W/kg)	Σ SAR (W/kg)
Body SAR	Back	0.646	0.386	1.032	Body SAR	Back	0.663	0.386	1.049
	Top	0.558	0.261	0.819		Top	0.748	0.261	1.009
	Bottom	0.400	0.400	0.800		Bottom	0.400	0.400	0.800
	Right	0.400	0.243	0.643		Right	0.400	0.243	0.643
	Left	0.082	0.400	0.482		Left	0.086	0.400	0.486
Simult Tx	Configuration	LTE Band 4 (AWS) SAR (W/kg)	2.4 GHz WLAN SAR (W/kg)	Σ SAR (W/kg)	Simult Tx	Configuration	LTE Band 2 (PCS) SAR (W/kg)	2.4 GHz WLAN SAR (W/kg)	Σ SAR (W/kg)
Body SAR	Back	0.608	0.386	0.994	Body SAR	Back	0.528	0.386	0.914
	Top	0.400	0.261	0.661		Top	0.400	0.261	0.661
	Bottom	0.400	0.400	0.800		Bottom	0.400	0.400	0.800
	Right	0.266	0.243	0.509		Right	0.319	0.243	0.562
	Left	0.400	0.400	0.800		Left	0.400	0.400	0.800
Simult Tx	Configuration	LTE Band 7 SAR (W/kg)	2.4 GHz WLAN SAR (W/kg)	Σ SAR (W/kg)					
Body SAR	Back	0.733	0.386	1.119					
	Top	0.355	0.261	0.616					
	Bottom	0.400	0.400	0.800					
	Right	0.400	0.243	0.643					
	Left	0.173	0.400	0.573					

Table 11-3
Simultaneous Transmission Scenario with 5 GHz WLAN (Body at 0.0 cm)

Simult Tx	Configuration	UMTS 850 SAR (W/kg)	5 GHz WLAN SAR (W/kg)	Σ SAR (W/kg)	Simult Tx	Configuration	UMTS 1900 SAR (W/kg)	5 GHz WLAN SAR (W/kg)	Σ SAR (W/kg)
Body SAR	Back	0.475	0.352	0.827	Body SAR	Back	0.468	0.352	0.820
	Top	0.548	0.692	1.240		Top	0.400	0.692	1.092
	Bottom	0.400	0.400	0.800		Bottom	0.400	0.400	0.800
	Right	0.400	0.139	0.539		Right	0.307	0.139	0.446
	Left	0.078	0.400	0.478		Left	0.400	0.400	0.800
Simult Tx	Configuration	LTE Band 12 SAR (W/kg)	5 GHz WLAN SAR (W/kg)	Σ SAR (W/kg)	Simult Tx	Configuration	LTE Band 5 (Cell) SAR (W/kg)	5 GHz WLAN SAR (W/kg)	Σ SAR (W/kg)
Body SAR	Back	0.646	0.352	0.998	Body SAR	Back	0.663	0.352	1.015
	Top	0.558	0.692	1.250		Top	0.748	0.692	1.440
	Bottom	0.400	0.400	0.800		Bottom	0.400	0.400	0.800
	Right	0.400	0.139	0.539		Right	0.400	0.139	0.539
	Left	0.082	0.400	0.482		Left	0.086	0.400	0.486

FCC ID: ZNFV930	 PCTEST ENGINEERING LABORATORY, INC.	SAR EVALUATION REPORT		Reviewed by: Quality Manager
Document S/N: OY1506161253-R2.ZNF	Test Dates: 06/17/15 - 06/23/15	DUT Type: Portable Tablet	Page 77 of 88	

Simult Tx	Configuration	LTE Band 4 (AWS) SAR (W/kg)	5 GHz WLAN SAR (W/kg)	Σ SAR (W/kg)	Simult Tx	Configuration	LTE Band 2 (PCS) SAR (W/kg)	5 GHz WLAN SAR (W/kg)	Σ SAR (W/kg)
Body SAR	Back	0.608	0.352	0.960	Body SAR	Back	0.528	0.352	0.880
	Top	0.400	0.692	1.092		Top	0.400	0.692	1.092
	Bottom	0.400	0.400	0.800		Bottom	0.400	0.400	0.800
	Right	0.266	0.139	0.405		Right	0.319	0.139	0.458
	Left	0.400	0.400	0.800		Left	0.400	0.400	0.800

Simult Tx	Configuration	LTE Band 7 SAR (W/kg)	5 GHz WLAN SAR (W/kg)	Σ SAR (W/kg)
Body SAR	Back	0.733	0.352	1.085
	Top	0.355	0.692	1.047
	Bottom	0.400	0.400	0.800
	Right	0.400	0.139	0.539
	Left	0.173	0.400	0.573

**Table 11-4
Simultaneous Transmission Scenario with Bluetooth (Body at 0.0 cm)**

Simult Tx	Configuration	UMTS 850 SAR (W/kg)	Bluetooth SAR (W/kg)	Σ SAR (W/kg)	Simult Tx	Configuration	UMTS 1900 SAR (W/kg)	Bluetooth SAR (W/kg)	Σ SAR (W/kg)
Body SAR	Back	0.475	0.378	0.853	Body SAR	Back	0.468	0.378	0.846
	Top	0.548	0.378	0.926		Top	0.400	0.378	0.778
	Bottom	0.400	0.400	0.800		Bottom	0.400	0.400	0.800
	Right	0.400	0.378	0.778		Right	0.307	0.378	0.685
	Left	0.078	0.400	0.478		Left	0.400	0.400	0.800

Simult Tx	Configuration	LTE Band 12 SAR (W/kg)	Bluetooth SAR (W/kg)	Σ SAR (W/kg)	Simult Tx	Configuration	LTE Band 5 (Cell) SAR (W/kg)	Bluetooth SAR (W/kg)	Σ SAR (W/kg)
Body SAR	Back	0.646	0.378	1.024	Body SAR	Back	0.663	0.378	1.041
	Top	0.558	0.378	0.936		Top	0.748	0.378	1.126
	Bottom	0.400	0.400	0.800		Bottom	0.400	0.400	0.800
	Right	0.400	0.378	0.778		Right	0.400	0.378	0.778
	Left	0.082	0.400	0.482		Left	0.086	0.400	0.486

Simult Tx	Configuration	LTE Band 4 (AWS) SAR (W/kg)	Bluetooth SAR (W/kg)	Σ SAR (W/kg)	Simult Tx	Configuration	LTE Band 2 (PCS) SAR (W/kg)	Bluetooth SAR (W/kg)	Σ SAR (W/kg)
Body SAR	Back	0.608	0.378	0.986	Body SAR	Back	0.528	0.378	0.906
	Top	0.400	0.378	0.778		Top	0.400	0.378	0.778
	Bottom	0.400	0.400	0.800		Bottom	0.400	0.400	0.800
	Right	0.266	0.378	0.644		Right	0.319	0.378	0.697
	Left	0.400	0.400	0.800		Left	0.400	0.400	0.800

Simult Tx	Configuration	LTE Band 7 SAR (W/kg)	Bluetooth SAR (W/kg)	Σ SAR (W/kg)
Body SAR	Back	0.733	0.378	1.111
	Top	0.355	0.378	0.733
	Bottom	0.400	0.400	0.800
	Right	0.400	0.378	0.778
	Left	0.173	0.400	0.573

**Table 11-5
Simultaneous Transmission Scenario with 2.4 GHz WLAN (Body at 1.2 cm)**

Configuration	Mode	3G/4G SAR (W/kg)	2.4 GHz WLAN SAR (W/kg)	Σ SAR (W/kg)
		1	2	N/A
Back Side	UMTS 1900	0.598	<0.386	<0.984
Back Side	LTE Band 4 (AWS)	0.571	<0.386	<0.957
Back Side	LTE Band 2 (PCS)	0.729	<0.386	<1.115



FCC ID: ZNFV930	 PCTEST <small>ENGINEERING LABORATORY, INC.</small>	SAR EVALUATION REPORT		Reviewed by: Quality Manager
Document S/N: OY1506161253-R2.ZNF	Test Dates: 06/17/15 - 06/23/15	DUT Type: Portable Tablet		Page 78 of 88

Table 11-6
Simultaneous Transmission Scenario with 5 GHz WLAN (Body at 1.2 cm)

Configuration	Mode	3G/4G SAR (W/kg)	5 GHz WLAN SAR (W/kg)	Σ SAR (W/kg)
		1	2	N/A
Back Side	UMTS 1900	0.598	<0.352	<0.95
Back Side	LTE Band 4 (AWS)	0.571	<0.352	<0.923
Back Side	LTE Band 2 (PCS)	0.729	<0.352	<1.081

Table 11-7
Simultaneous Transmission Scenario with Bluetooth (Body at 1.2 cm)

Configuration	Mode	3G/4G SAR (W/kg)	Bluetooth SAR (W/kg)	Σ SAR (W/kg)
		0.598	0.157	0.755
Back Side	UMTS 1900	0.598	0.157	0.755
Back Side	LTE Band 4 (AWS)	0.571	0.157	0.728
Back Side	LTE Band 2 (PCS)	0.729	0.157	0.886

Table 11-8
Simultaneous Transmission Scenario with 2.4 GHz WLAN (Body at 1.6 cm)

Configuration	Mode	3G/4G SAR (W/kg)	2.4 GHz WLAN SAR (W/kg)	Σ SAR (W/kg)
		0.413	<0.386	<0.799
Back Side	UMTS 850	0.413	<0.386	<0.799
Back Side	LTE Band 12	0.399	<0.386	<0.785
Back Side	LTE Band 5 (Cell)	0.498	<0.386	< 0.884
Back Side	LTE Band 7	0.394	<0.386	<0.780

Table 11-9
Simultaneous Transmission Scenario with 5 GHz WLAN (Body at 1.6 cm)

Configuration	Mode	3G/4G SAR (W/kg)	5 GHz WLAN SAR (W/kg)	Σ SAR (W/kg)
		0.413	<0.352	<0.765
Back Side	UMTS 850	0.413	<0.352	<0.765
Back Side	LTE Band 12	0.399	<0.352	<0.751
Back Side	LTE Band 5 (Cell)	0.498	<0.352	< 0.850
Back Side	LTE Band 7	0.394	<0.352	<0.746

Table 11-10
Simultaneous Transmission Scenario with Bluetooth (Body at 1.6 cm)

Configuration	Mode	3G/4G SAR (W/kg)	Bluetooth SAR (W/kg)	Σ SAR (W/kg)
		0.413	0.118	0.531
Back Side	UMTS 850	0.413	0.118	0.531
Back Side	LTE Band 12	0.399	0.118	0.517
Back Side	LTE Band 5 (Cell)	0.498	0.118	0.616
Back Side	LTE Band 7	0.394	0.118	0.512



FCC ID: ZNFV930	 PCTEST ENGINEERING LABORATORY, INC.	SAR EVALUATION REPORT	 LG	Reviewed by: Quality Manager
Document S/N: OY1506161253-R2.ZNF	Test Dates: 06/17/15 - 06/23/15	DUT Type: Portable Tablet		Page 79 of 88

Table 11-11
Simultaneous Transmission Scenario with 2.4 GHz WLAN (Body at 1.9cm)

Configuration	Mode	3G/4G SAR (W/kg)	2.4 GHz WLAN SAR (W/kg)	Σ SAR (W/kg)
Top Edge	UMTS 850	0.283	<0.261	<0.544
Top Edge	UMTS 1900	0.400	<0.261	<0.661
Top Edge	LTE Band 12	0.271	<0.261	<0.532
Top Edge	LTE Band 5 (Cell)	0.411	<0.261	<0.672
Top Edge	LTE Band 4 (AWS)	0.400	<0.261	<0.661
Top Edge	LTE Band 2 (PCS)	0.400	<0.261	<0.661
Top Edge	LTE Band 7	0.213	<0.261	<0.474

Table 11-12
Simultaneous Transmission Scenario with 5 GHz WLAN (Body at 1.9 cm)

Configuration	Mode	3G/4G SAR (W/kg)	5 GHz WLAN SAR (W/kg)	Σ SAR (W/kg)
Top Edge	UMTS 850	0.283	<0.692	<0.975
Top Edge	UMTS 1900	0.400	<0.692	<1.092
Top Edge	LTE Band 12	0.271	<0.692	<0.963
Top Edge	LTE Band 5 (Cell)	0.411	<0.692	<1.103
Top Edge	LTE Band 4 (AWS)	0.400	<0.692	<1.092
Top Edge	LTE Band 2 (PCS)	0.400	<0.692	<1.092
Top Edge	LTE Band 7	0.213	<0.692	<0.905

Table 11-13
Simultaneous Transmission Scenario with Bluetooth (Body at 1.9 cm)

Configuration	Mode	3G/4G SAR (W/kg)	Bluetooth SAR (W/kg)	Σ SAR (W/kg)
Top Edge	UMTS 850	0.283	0.099	0.382
Top Edge	UMTS 1900	0.400	0.099	0.499
Top Edge	LTE Band 12	0.271	0.099	0.370
Top Edge	LTE Band 5 (Cell)	0.411	0.099	0.510
Top Edge	LTE Band 4 (AWS)	0.400	0.099	0.499
Top Edge	LTE Band 2 (PCS)	0.400	0.099	0.499
Top Edge	LTE Band 7	0.213	0.099	0.312

Table 11-14
Simultaneous Transmission Scenario with 2.4 GHz WLAN (Body at 1.4 cm)

Configuration	Mode	3G/4G SAR (W/kg)	2.4 GHz WLAN SAR (W/kg)	Σ SAR (W/kg)
Right Edge	UMTS 850	0.400	<0.243	<0.643
Right Edge	UMTS 1900	0.489	<0.243	<0.732
Right Edge	LTE Band 12	0.400	<0.243	<0.643
Right Edge	LTE Band 5 (Cell)	0.400	<0.243	<0.643
Right Edge	LTE Band 4 (AWS)	0.576	<0.243	<0.819
Right Edge	LTE Band 2 (PCS)	0.546	<0.243	<0.789
Right Edge	LTE Band 7	0.400	<0.243	<0.643

Table 11-15
Simultaneous Transmission Scenario with 5 GHz WLAN (Body at 1.4 cm)

Configuration	Mode	3G/4G SAR (W/kg)	5 GHz WLAN SAR (W/kg)	Σ SAR (W/kg)
Right Edge	UMTS 850	0.400	<0.139	<0.539
Right Edge	UMTS 1900	0.489	<0.139	<0.628
Right Edge	LTE Band 12	0.400	<0.139	<0.539
Right Edge	LTE Band 5 (Cell)	0.400	<0.139	<0.539
Right Edge	LTE Band 4 (AWS)	0.576	<0.139	<0.715
Right Edge	LTE Band 2 (PCS)	0.546	<0.139	<0.685
Right Edge	LTE Band 7	0.400	<0.139	<0.539



FCC ID: ZNFV930	 SAR EVALUATION REPORT 		Reviewed by: Quality Manager
Document S/N: OY1506161253-R2.ZNF	Test Dates: 06/17/15 - 06/23/15	DUT Type: Portable Tablet	Page 80 of 88

Table 11-16
Simultaneous Transmission Scenario with Bluetooth (Body at 1.4 cm)



Configuration	Mode	3G/4G SAR (W/kg)	Bluetooth SAR (W/kg)	Σ SAR (W/kg)
Right Edge	UMTS 850	0.400	0.135	0.535
Right Edge	UMTS 1900	0.489	0.135	0.624
Right Edge	LTE Band 12	0.400	0.135	0.535
Right Edge	LTE Band 5 (Cell)	0.400	0.135	0.535
Right Edge	LTE Band 4 (AWS)	0.576	0.135	0.711
Right Edge	LTE Band 2 (PCS)	0.546	0.135	0.681
Right Edge	LTE Band 7	0.400	0.135	0.535

Notes:

1. For SAR summation for body (back side at 12 mm and 16 mm), WLAN SAR values for 0 mm were used since the 0 mm test distance for WLAN SAR was more conservative. "<" denotes that the 0 mm WLAN SAR values were used for summation purposes.
2. For SAR summation for body (top edge at 19 mm), WLAN SAR values for 0 mm were used since the 0 mm test distance for WLAN SAR was more conservative. "<" denotes that the 0 mm WLAN SAR were used for summation purposes.
3. For SAR summation for body (right edge at 14 mm) WLAN SAR values for 0 mm were used since the 0 mm test distance for WLAN SAR value was more conservative. "<" denotes that the 0 mm WLAN SAR were used for summation purposes.

11.4 Simultaneous Transmission Conclusion

The above numerical summed SAR results for all the worst-case simultaneous transmission conditions were below the SAR limit. Therefore, the above analysis is sufficient to determine that simultaneous transmission cases will not exceed the SAR limit and therefore no measured volumetric simultaneous SAR summation is required per FCC KDB Publication 447498 D01v05 and IEEE 1528-2013 Section 6.3.4.1.2.

FCC ID: ZNFV930	 PCTEST <small>ENGINEERING LABORATORY, INC.</small>	SAR EVALUATION REPORT		Reviewed by: Quality Manager
Document S/N: OY1506161253-R2.ZNF	Test Dates: 06/17/15 - 06/23/15	DUT Type: Portable Tablet	Page 81 of 88	



12 SAR MEASUREMENT VARIABILITY

12.1 Measurement Variability

Per FCC KDB Publication 865664 D01v01, SAR measurement variability analysis was not required since all measured SAR values were < 0.8 W/kg.

12.2 Measurement Uncertainty

The measured SAR was < 1.5 W/kg for all frequency bands. Therefore, per KDB Publication 865664 D01v01, the extended measurement uncertainty analysis per IEEE 1528-2003 was not required.

FCC ID: ZNFV930	 PCTEST ENGINEERING LABORATORY, INC.	SAR EVALUATION REPORT	 LG	Reviewed by: Quality Manager
Document S/N: 0Y1506161253-R2.ZNF	Test Dates: 06/17/15 - 06/23/15	DUT Type: Portable Tablet	Page 82 of 88	

© 2015 PCTEST Engineering Laboratory, Inc.



REV 16.0 M
06/12/2015

(c) 2015 PCTEST Engineering Laboratory, Inc. All rights reserved. Unless otherwise specified, no part of this report may be reproduced or utilized in any part, form or by any means, electronic or mechanical, including photocopying and microfilm, without permission in writing from PCTEST Engineering Laboratory, Inc. If you have any questions about this international copyright or have an enquiry about obtaining additional rights to this report or assembly of contents thereof, please contact info@pctestlab.com.

13 EQUIPMENT LIST

Manufacturer	Model	Description	Cal Date	Cal Interval	Cal Due	Serial Number
Gigatronics	80701A	(0.05-18GHz) Power Sensor	10/30/2014	Annual	10/30/2015	1833460
Agilent	E8257D	(250kHz-20GHz) Signal Generator	3/15/2015	Annual	3/15/2016	MY45470194
Agilent	8753E	(30kHz-6GHz) Network Analyzer	12/30/2014	Annual	12/30/2015	JP38020182
Agilent	8594A	(9kHz-2.9GHz) Spectrum Analyzer	N/A	N/A	N/A	3051A00187
Agilent	8648D	(9kHz-4GHz) Signal Generator	3/15/2015	Annual	3/15/2016	3629U00687
SPEAG	D1765V2	1765 MHz SAR Dipole	5/13/2015	Annual	5/13/2016	1008
SPEAG	D1900V2	1900 MHz SAR Dipole	2/18/2015	Annual	2/18/2016	5d148
SPEAG	D2450V2	2450 MHz SAR Dipole	2/18/2015	Annual	2/18/2016	882
SPEAG	D2600V2	2600 MHz SAR Dipole	4/14/2015	Annual	4/14/2016	1004
Narda	4014C-6	4 - 8 GHz SMA 6 dB Directional Coupler	CBT	N/A	CBT	N/A
SPEAG	D5GHzV2	5 GHz SAR Dipole	9/25/2014	Annual	9/25/2015	1191
MCL	BW-N6W5+	6dB Attenuator	CBT	N/A	CBT	1139
SPEAG	D750V3	750 MHz Dipole	2/19/2015	Annual	2/19/2016	1046
SPEAG	D835V2	835 MHz SAR Dipole	4/13/2015	Annual	4/13/2016	4d119
Amplifier Research	1551G6	Amplifier	CBT	N/A	CBT	433978
Narda	BW-S3W2	Attenuator (3dB)	CBT	N/A	CBT	120
Rohde & Schwarz	CMU200	Base Station Simulator	3/23/2015	Annual	3/23/2016	836371/0079
Pasternack	PE2208-6	Bidirectional Coupler	CBT	N/A	CBT	N/A
Pasternack	PE2209-10	Bidirectional Coupler	CBT	N/A	CBT	N/A
SPEAG	DAE4	Dasy Data Acquisition Electronics	10/31/2014	Annual	10/31/2015	1333
SPEAG	DAE4	Dasy Data Acquisition Electronics	12/12/2014	Annual	12/12/2015	1415
Mini-Circuits	BW-N20W5+	DC to 18 GHz Precision Fixed 20 dB Attenuator	CBT	N/A	CBT	N/A
SPEAG	DAK-3.5	Dielectric Assessment Kit	5/12/2015	Annual	5/12/2016	1070
Mitutoyo	CD-6"CSX	Digital Caliper	5/8/2014	Biennial	5/8/2016	13264165
Control Company	4040	Digital Thermometer	3/18/2015	Biennial	3/18/2017	150194896
Keysight	772D	Dual Directional Coupler	CBT	N/A	CBT	MY52180215
Agilent	E4438C	ESG Vector Signal Generator	4/1/2014	Biennial	4/1/2016	MY47270002
Agilent	E4438C	ESG Vector Signal Generator	3/15/2015	Annual	3/15/2016	MY45091346
Agilent	E4432B	ESG-D Series Signal Generator	3/16/2015	Annual	3/16/2016	US40053896
Control Company	61220-416	Long-Stem Thermometer	4/29/2014	Biennial	4/29/2016	111331323
MiniCircuits	VLf-6000+	Low Pass Filter	CBT	N/A	CBT	N/A
MiniCircuits	SLP-2400+	Low Pass Filter	CBT	N/A	CBT	R8979500903
Mini-Circuits	NLP-1200+	Low Pass Filter DC to 1000 MHz	CBT	N/A	CBT	N/A
Mini-Circuits	NLP-2950+	Low Pass Filter DC to 2700 MHz	CBT	N/A	CBT	N/A
Agilent	N9020A	MXA Signal Analyzer	10/27/2014	Annual	10/27/2015	US46470561
Agilent	N5182A	MXG Vector Signal Generator	3/16/2015	Annual	3/16/2016	MY47420651
Agilent	8753ES	Network Analyzer	3/20/2015	Annual	3/20/2016	MY40001472
SPEAG	DAKS-3.5	Portable Dielectric Assessment Kit	8/12/2014	Annual	8/12/2015	1041
Mini-Circuits	BW-N20W5	Power Attenuator	CBT	N/A	CBT	1226
Anritsu	ML2495A	Power Meter	10/31/2013	Biennial	10/31/2015	941001
Anritsu	ML2495A	Power Meter	10/31/2013	Biennial	10/31/2015	1039008
Anritsu	ML2496A	Power Meter	3/13/2015	Annual	3/13/2016	1351001
Anritsu	ML2496A	Power Meter	3/13/2015	Annual	3/13/2016	1306009
Anritsu	MA2481A	Power Sensor	3/10/2015	Annual	3/10/2016	2400
Anritsu	MA2481A	Power Sensor	3/11/2015	Annual	3/11/2016	5318
Anritsu	MA2411B	Pulse Power Sensor	11/17/2014	Annual	11/17/2015	1126066
Anritsu	MA2411B	Pulse Power Sensor	3/13/2015	Annual	3/13/2016	1207470
Anritsu	MT8820C	Radio Communication Analyzer	3/10/2015	Annual	3/10/2016	6200901190
Anritsu	MT8820C	Radio Communication Analyzer	8/28/2014	Annual	8/28/2015	6201240328
Rohde & Schwarz	CMW500	Radio Communication Tester	6/1/2015	Annual	6/1/2016	108843
SPEAG	ES3DV3	SAR Probe	8/20/2014	Annual	8/20/2015	3331
SPEAG	ES3DV3	SAR Probe	12/16/2014	Annual	12/16/2015	3334
SPEAG	EX3DV4	SAR Probe	2/10/2015	Annual	2/10/2016	3914
COMTech	AR85729-5	Solid State Amplifier	CBT	N/A	CBT	M155A00-009
Agilent	8753ES	S-Parameter Network Analyzer	3/12/2015	Annual	3/12/2016	MY40000670
Seekonk	NC-100	Torque Wrench	3/18/2014	Biennial	3/18/2016	N/A
Seekonk	NC-100	Torque Wrench 5/16", 8" lbs	3/18/2014	Biennial	3/18/2016	N/A
Gigatronics	8651A	Universal Power Meter	10/30/2014	Annual	10/30/2015	8650319
Anritsu	MA24106A	USB Power Sensor	5/29/2015	Annual	5/29/2016	1248508
Anritsu	MA24106A	USB Power Sensor	5/29/2015	Annual	5/29/2016	1244524
Control Company	36934-158	Wall-Mounted Thermometer	4/29/2014	Biennial	4/29/2016	122014488
Agilent	E5515C	Wireless Communications Test Set	5/16/2015	Biennial	5/16/2017	GB43304447

Note: CBT (Calibrated Before Testing). Prior to testing, the measurement paths containing a cable, amplifier, attenuator, coupler or filter were connected to a calibrated source (i.e. a signal generator) to determine the losses of the measurement path. The power meter offset was then adjusted to compensate for the measurement system losses. This level offset is stored within the power meter before measurements are made. This calibration verification procedure applies to the system verification and output power measurements. The calibrated reading is then taken directly from the power meter after compensation of the losses for all final power measurements.



FCC ID: ZNFV930	 PCTEST ENGINEERING LABORATORY, INC.	SAR EVALUATION REPORT		Reviewed by: Quality Manager
Document S/N: OY1506161253-R2.ZNF	Test Dates: 06/17/15 - 06/23/15	DUT Type: Portable Tablet	Page 83 of 88	

14 MEASUREMENT UNCERTAINTIES

Applicable for frequencies less than 3000 MHz.

a	b	c	d	e= f(d,k)	f	g	h = c x f/e	i = c x g/e	k	
Uncertainty Component	IEEE 1528 Sec.	Tol. (± %)	Prob. Dist.	Div.	c _i 1gm	c _i 10 gms	1gm u _i (± %)	10gms u _i (± %)	v _i	
Measurement System										
Probe Calibration	E.2.1	6.0	N	1	1.0	1.0	6.0	6.0	∞	
Axial Isotropy	E.2.2	0.25	N	1	0.7	0.7	0.2	0.2	∞	
Hemishperical Isotropy	E.2.2	1.3	N	1	1.0	1.0	1.3	1.3	∞	
Boundary Effect	E.2.3	0.4	N	1	1.0	1.0	0.4	0.4	∞	
Linearity	E.2.4	0.3	N	1	1.0	1.0	0.3	0.3	∞	
System Detection Limits	E.2.5	5.1	N	1	1.0	1.0	5.1	5.1	∞	
Readout Electronics	E.2.6	1.0	N	1	1.0	1.0	1.0	1.0	∞	
Response Time	E.2.7	0.8	R	1.73	1.0	1.0	0.5	0.5	∞	
Integration Time	E.2.8	2.6	R	1.73	1.0	1.0	1.5	1.5	∞	
RF Ambient Conditions	E.6.1	3.0	R	1.73	1.0	1.0	1.7	1.7	∞	
Probe Positioner Mechanical Tolerance	E.6.2	0.4	R	1.73	1.0	1.0	0.2	0.2	∞	
Probe Positioning w/ respect to Phantom	E.6.3	2.9	R	1.73	1.0	1.0	1.7	1.7	∞	
Extrapolation, Interpolation & Integration algorithms for Max. SAR Evaluation	E.5	1.0	R	1.73	1.0	1.0	0.6	0.6	∞	
Test Sample Related										
Test Sample Positioning	E.4.2	6.0	N	1	1.0	1.0	6.0	6.0	287	
Device Holder Uncertainty	E.4.1	3.32	R	1.73	1.0	1.0	1.9	1.9	∞	
Output Power Variation - SAR drift measurement	6.6.2	5.0	R	1.73	1.0	1.0	2.9	2.9	∞	
Phantom & Tissue Parameters										
Phantom Uncertainty (Shape & Thickness tolerances)	E.3.1	4.0	R	1.73	1.0	1.0	2.3	2.3	∞	
Liquid Conductivity - deviation from target values	E.3.2	5.0	R	1.73	0.64	0.43	1.8	1.2	∞	
Liquid Conductivity - measurement uncertainty	E.3.3	3.8	N	1	0.64	0.43	2.4	1.6	6	
Liquid Permittivity - deviation from target values	E.3.2	5.0	R	1.73	0.60	0.49	1.7	1.4	∞	
Liquid Permittivity - measurement uncertainty	E.3.3	4.5	N	1	0.60	0.49	2.7	2.2	6	
Combined Standard Uncertainty (k=1)							RSS	12.1	11.7	299
Expanded Uncertainty (95% CONFIDENCE LEVEL)							k=2	24.2	23.5	

The above measurement uncertainties are according to IEEE Std. 1528-2003

FCC ID: ZNFV930	 PCTEST ENGINEERING LABORATORY, INC.	SAR EVALUATION REPORT		Reviewed by: Quality Manager
Document S/N: OY1506161253-R2.ZNF	Test Dates: 06/17/15 - 06/23/15	DUT Type: Portable Tablet		Page 84 of 88

© 2015 PCTEST Engineering Laboratory, Inc.



REV 16.0 M
06/12/2015

(c) 2015 PCTEST Engineering Laboratory, Inc. All rights reserved. Unless otherwise specified, no part of this report may be reproduced or utilized in any part, form or by any means, electronic or mechanical, including photocopying and microfilm, without permission in writing from PCTEST Engineering Laboratory, Inc. If you have any questions about this international copyright or have an enquiry about obtaining additional rights to this report or assembly of contents thereof, please contact info@pctestlab.com.

Applicable for frequencies up to 6 GHz.

a	b	c	d	e= f(d,k)	f	g	h= c x f/e	i= c x g/e	k
Uncertainty Component	IEEE 1528 Sec.	Tol. (± %)	Prob. Dist.	Div.	c _i 1gm	c _i 10 gms	1gm u _i (± %)	10gms u _i (± %)	v _i
Measurement System									
Probe Calibration	E.2.1	6.55	N	1	1.0	1.0	6.6	6.6	∞
Axial Isotropy	E.2.2	0.25	N	1	0.7	0.7	0.2	0.2	∞
Hemishperical Isotropy	E.2.2	1.3	N	1	1.0	1.0	1.3	1.3	∞
Boundary E effect	E.2.3	0.4	N	1	1.0	1.0	0.4	0.4	∞
Linearity	E.2.4	0.3	N	1	1.0	1.0	0.3	0.3	∞
System Detection Limits	E.2.5	5.1	N	1	1.0	1.0	5.1	5.1	∞
Readout Electronics	E.2.6	1.0	N	1	1.0	1.0	1.0	1.0	∞
Response Time	E.2.7	0.8	R	1.73	1.0	1.0	0.5	0.5	∞
Integration Time	E.2.8	2.6	R	1.73	1.0	1.0	1.5	1.5	∞
RF Ambient Conditions	E.6.1	3.0	R	1.73	1.0	1.0	1.7	1.7	∞
Probe Positioner Mechanical Tolerance	E.6.2	0.4	R	1.73	1.0	1.0	0.2	0.2	∞
Probe Positioning w/ respect to Phantom	E.6.3	2.9	R	1.73	1.0	1.0	1.7	1.7	∞
Extrapolation, Interpolation & Integration algorithms for Max. SAR Evaluation	E.5	1.0	R	1.73	1.0	1.0	0.6	0.6	∞
Test Sample Related									
Test Sample Positioning	E.4.2	6.0	N	1	1.0	1.0	6.0	6.0	287
Device Holder Uncertainty	E.4.1	3.32	R	1.73	1.0	1.0	1.9	1.9	∞
Output Power Variation - SAR drift measurement	6.6.2	5.0	R	1.73	1.0	1.0	2.9	2.9	∞
Phantom & Tissue Parameters									
Phantom Uncertainty (Shape & Thickness tolerances)	E.3.1	4.0	R	1.73	1.0	1.0	2.3	2.3	∞
Liquid Conductivity - deviation from target values	E.3.2	5.0	R	1.73	0.64	0.43	1.8	1.2	∞
Liquid Conductivity - measurement uncertainty	E.3.3	3.8	N	1	0.64	0.43	2.4	1.6	6
Liquid Permittivity - deviation from target values	E.3.2	5.0	R	1.73	0.60	0.49	1.7	1.4	∞
Liquid Permittivity - measurement uncertainty	E.3.3	4.5	N	1	0.60	0.49	2.7	2.2	6
Combined Standard Uncertainty (k=1)				RSS			12.4	12.0	299
Expanded Uncertainty (95% CONFIDENCE LEVEL)				k=2			24.7	24.0	

The above measurement uncertainties are according to IEEE Std. 1528-2003



FCC ID: ZNFV930	 PCTEST ENGINEERING LABORATORY, INC.	SAR EVALUATION REPORT		Reviewed by: Quality Manager
Document S/N: OY1506161253-R2.ZNF	Test Dates: 06/17/15 - 06/23/15	DUT Type: Portable Tablet		Page 85 of 88

15 CONCLUSION

15.1 Measurement Conclusion



The SAR evaluation indicates that the EUT complies with the RF radiation exposure limits of the FCC and Industry Canada, with respect to all parameters subject to this test. These measurements were taken to simulate the RF effects of RF exposure under worst-case conditions. Precise laboratory measures were taken to assure repeatability of the tests. The results and statements relate only to the item(s) tested.

Please note that the absorption and distribution of electromagnetic energy in the body are very complex phenomena that depend on the mass, shape, and size of the body, the orientation of the body with respect to the field vectors, and the electrical properties of both the body and the environment. Other variables that may play a substantial role in possible biological effects are those that characterize the environment (e.g. ambient temperature, air velocity, relative humidity, and body insulation) and those that characterize the individual (e.g. age, gender, activity level, debilitation, or disease). Because various factors may interact with one another to vary the specific biological outcome of an exposure to electromagnetic fields, any protection guide should consider maximal amplification of biological effects as a result of field-body interactions, environmental conditions, and physiological variables. [3]



FCC ID: ZNFV930	 PCTEST ENGINEERING LABORATORY, INC.	SAR EVALUATION REPORT	 LG	Reviewed by: Quality Manager
Document S/N: 0Y1506161253-R2.ZNF	Test Dates: 06/17/15 - 06/23/15	DUT Type: Portable Tablet		Page 86 of 88

16 REFERENCES

- [1] Federal Communications Commission, ET Docket 93-62, Guidelines for Evaluating the Environmental Effects of Radiofrequency Radiation, Aug. 1996.
- [2] ANSI/IEEE C95.1-2005, American National Standard safety levels with respect to human exposure to radio frequency electromagnetic fields, 3kHz to 300GHz, New York: IEEE, 2006.
- [3] ANSI/IEEE C95.1-1992, American National Standard safety levels with respect to human exposure to radio frequency electromagnetic fields, 3kHz to 300GHz, New York: IEEE, Sept. 1992.
- [4] ANSI/IEEE C95.3-2002, IEEE Recommended Practice for the Measurement of Potentially Hazardous Electromagnetic Fields - RF and Microwave, New York: IEEE, December 2002.
- [5] IEEE Standards Coordinating Committee 39 –Standards Coordinating Committee 34 – IEEE Std. 1528-2003, Recommended Practice for Determining the Peak Spatial-Average Specific Absorption Rate (SAR) in the Human Head Due to Wireless Communications Devices: Measurement Techniques.
- [6] NCRP, National Council on Radiation Protection and Measurements, Biological Effects and Exposure Criteria for RadioFrequency Electromagnetic Fields, NCRP Report No. 86, 1986. Reprinted Feb. 1995.
- [7] T. Schmid, O. Egger, N. Kuster, Automated E-field scanning system for dosimetric assessments, IEEE Transaction on Microwave Theory and Techniques, vol. 44, Jan. 1996, pp. 105-113.
- [8] K. Pokovic, T. Schmid, N. Kuster, Robust setup for precise calibration of E-field probes in tissue simulating liquids at mobile communications frequencies, ICECOM97, Oct. 1997, pp. 1 -124.
- [9] K. Pokovic, T. Schmid, and N. Kuster, E-field Probe with improved isotropy in brain simulating liquids, Proceedings of the ELMAR, Zadar, Croatia, June 23-25, 1996, pp. 172-175.
- [10] Schmid & Partner Engineering AG, Application Note: Data Storage and Evaluation, June 1998, p2.
- [11] V. Hombach, K. Meier, M. Burkhardt, E. Kuhn, N. Kuster, The Dependence of EM Energy Absorption upon Human Modeling at 900 MHz, IEEE Transaction on Microwave Theory and Techniques, vol. 44 no. 10, Oct. 1996, pp. 1865-1873.
- [12] N. Kuster and Q. Balzano, Energy absorption mechanism by biological bodies in the near field of dipole antennas above 300MHz, IEEE Transaction on Vehicular Technology, vol. 41, no. 1, Feb. 1992, pp. 17-23.
- [13] G. Hartsgrrove, A. Kraszewski, A. Surowiec, Simulated Biological Materials for Electromagnetic Radiation Absorption Studies, University of Ottawa, Bioelectromagnetics, Canada: 1987, pp. 29-36.
- [14] Q. Balzano, O. Garay, T. Manning Jr., Electromagnetic Energy Exposure of Simulated Users of Portable Cellular Telephones, IEEE Transactions on Vehicular Technology, vol. 44, no.3, Aug. 1995.
- [15] W. Gander, Computermathematick, Birkhaeuser, Basel, 1992.
- [16] W.H. Press, S.A. Teukolsky, W.T. Vetterling, and B.P. Flannery, Numerical Recipes in C, The Art of Scientific Computing, Second edition, Cambridge University Press, 1992.
- [17] N. Kuster, R. Kastle, T. Schmid, Dosimetric evaluation of mobile communications equipment with known precision, IEEE Transaction on Communications, vol. E80-B, no. 5, May 1997, pp. 645-652.

FCC ID: ZNFV930	 SAR EVALUATION REPORT 		Reviewed by: Quality Manager
Document S/N: OY1506161253-R2.ZNF	Test Dates: 06/17/15 - 06/23/15	DUT Type: Portable Tablet	Page 87 of 88

- [18] CENELEC CLC/SC111B, European Prestandard (prENV 50166-2), Human Exposure to Electromagnetic Fields High-frequency: 10kHz-300GHz, Jan. 1995.
- [19] Prof. Dr. Niels Kuster, ETH, Eidgenössische Technische Hochschule Zürich, Dosimetric Evaluation of the Cellular Phone.
- [20] IEC 62209-1, Human exposure to radio frequency fields from hand-held and body-mounted wireless communication devices - Human models, instrumentation, and procedures - Part 1: Procedure to determine the specific absorption rate (SAR) for hand-held devices used in close proximity to the ear (frequency range of 300 MHz to 3 GHz), Feb. 2005.
- [21] Industry Canada RSS-102 Radio Frequency Exposure Compliance of Radiocommunication Apparatus (All Frequency Bands) Issue 4, March 2010.
- [22] Health Canada Safety Code 6 Limits of Human Exposure to Radio Frequency Electromagnetic Fields in the Frequency Range from 3 kHz – 300 GHz, 2009
- [23] FCC SAR Test Procedures for 2G-3G Devices, Mobile Hotspot and UMPC Devices KDB Publications 941225, D01-D07
- [24] SAR Measurement Guidance for IEEE 802.11 Transmitters, KDB Publication 248227 D01v02r01
- [25] FCC SAR Considerations for Handsets with Multiple Transmitters and Antennas, KDB Publications 648474 D03-D04
- [26] FCC SAR Evaluation Considerations for Laptop, Notebook, Netbook and Tablet Computers, FCC KDB Publication 616217 D04
- [27] FCC SAR Measurement and Reporting Requirements for 100MHz – 6 GHz, KDB Publications 865664 D01-D02
- [28] FCC General RF Exposure Guidance and SAR Procedures for Dongles, KDB Publication 447498, D01-D02
- [29] Anexo à Resolução No. 533, de 10 de Setembro de 2009.
- [30] IEC 62209-2, Human exposure to radio frequency fields from hand-held and body-mounted wireless communication devices - Human models, instrumentation, and procedures - Part 2: Procedure to determine the specific absorption rate (SAR) for wireless communication devices used in close proximity to the human body (frequency range of 30 MHz to 6 GHz), Mar. 2010.

FCC ID: ZNFV930	 PCTEST ENGINEERING LABORATORY, INC.	SAR EVALUATION REPORT	 LG	Reviewed by: Quality Manager
Document S/N: OY1506161253-R2.ZNF	Test Dates: 06/17/15 - 06/23/15	DUT Type: Portable Tablet		Page 88 of 88

APPENDIX A: SAR TEST DATA

PCTEST ENGINEERING LABORATORY, INC.

DUT: ZNFV930; Type: Portable Tablet; Serial: 02256

Communication System: UID 0, UMTS; Frequency: 836.6 MHz; Duty Cycle: 1:1
Medium: 835 Body Medium parameters used (interpolated):
 $f = 836.6 \text{ MHz}$; $\sigma = 0.999 \text{ S/m}$; $\epsilon_r = 52.965$; $\rho = 1000 \text{ kg/m}^3$
Phantom section: Flat Section ; Space: 0.0 cm

Test Date: 06-19-2015; Ambient Temp: 23.5°C; Tissue Temp: 22.5°C

Probe: ES3DV3 - SN3331; ConvF(6.14, 6.14, 6.14); Calibrated: 8/20/2014;
Sensor-Surface: 3mm (Mechanical Surface Detection)
Electronics: DAE4 Sn1333; Calibrated: 10/31/2014
Phantom: SAM Main ; Type: QD000P40CC; Serial: TP 1114
Measurement SW: DASY52, Version 52.8 (8); SEMCAD X Version 14.6.10 (7331)

Mode: UMTS 850, Body SAR, Top Edge, Mid.ch

Area Scan (11x15x1): Measurement grid: dx=5mm, dy=15mm

Zoom Scan (5x5x7)/Cube 0: Measurement grid: dx=8mm, dy=8mm, dz=5mm

Reference Value = 24.54 V/m; Power Drift = -0.02 dB

Peak SAR (extrapolated) = 1.03 W/kg

SAR(1 g) = 0.536 W/kg

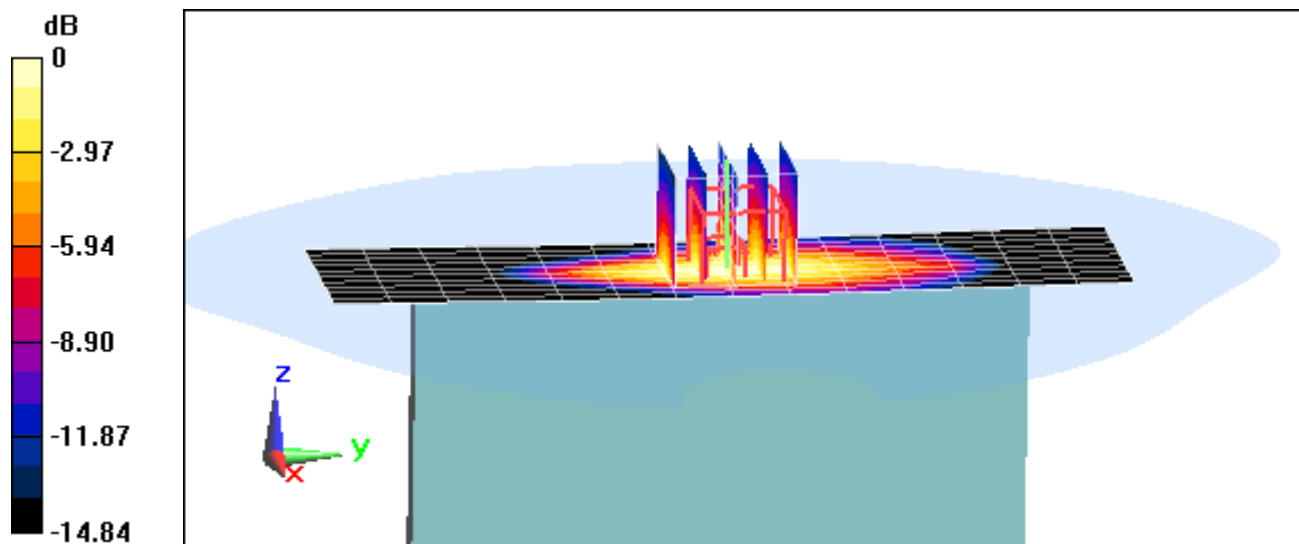

0 dB = 0.694 W/kg = -1.59 dBW/kg

PCTEST ENGINEERING LABORATORY, INC.

DUT: ZNFV930; Type: Portable Tablet; Serial: 02231

Communication System: UID 0, UMTS; Frequency: 1880 MHz; Duty Cycle: 1:1
Medium: 1900 Body Medium parameters used:
 $f = 1880 \text{ MHz}$; $\sigma = 1.53 \text{ S/m}$; $\epsilon_r = 51.272$; $\rho = 1000 \text{ kg/m}^3$
Phantom section: Flat Section ; Space: 1.2 cm

Test Date: 06-17-2015; Ambient Temp: 24.3°C; Tissue Temp: 22.8°C

Probe: ES3DV3 - SN3331; ConvF(4.73, 4.73, 4.73); Calibrated: 8/20/2014;
Sensor-Surface: 3mm (Mechanical Surface Detection)
Electronics: DAE4 Sn1333; Calibrated: 10/31/2014
Phantom: SAM Sub ; Type: QD000P40CC; Serial: TP:1357
Measurement SW: DASY52, Version 52.8 (8); SEMCAD X Version 14.6.10 (7331)

Mode: UMTS 1900, Body SAR, Back side, Mid.ch

Area Scan (13x19x1): Measurement grid: dx=15mm, dy=15mm

Zoom Scan (5x5x7)/Cube 0: Measurement grid: dx=8mm, dy=8mm, dz=5mm

Reference Value = 21.18 V/m; Power Drift = -0.01 dB

Peak SAR (extrapolated) = 1.05 W/kg

SAR(1 g) = 0.598 W/kg

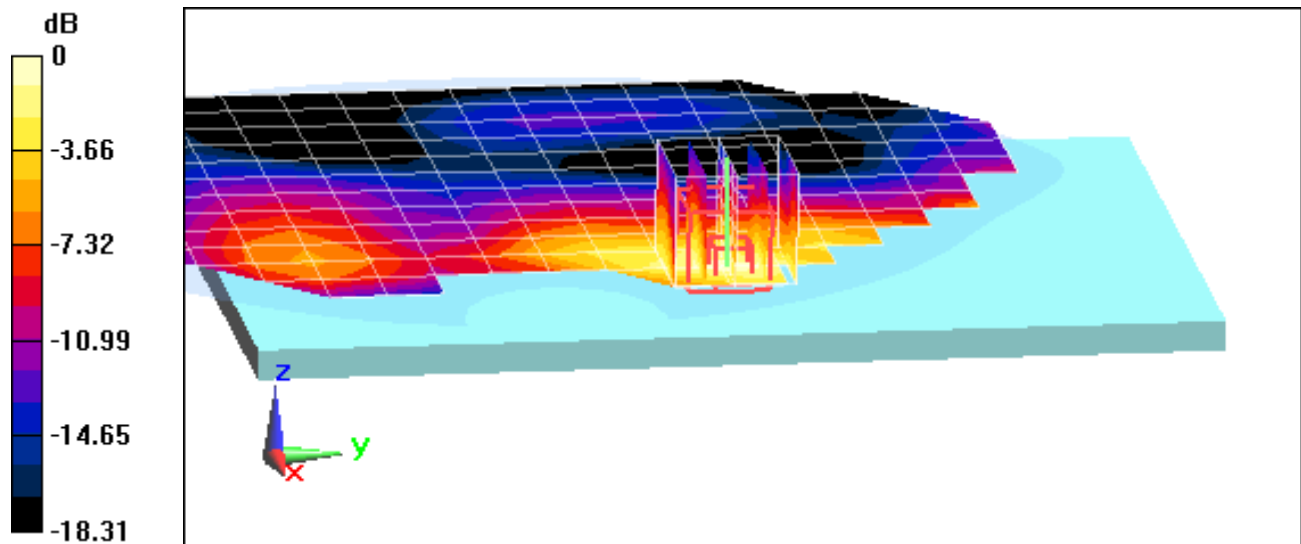

0 dB = 0.736 W/kg = -1.33 dBW/kg

PCTEST ENGINEERING LABORATORY, INC.

DUT: ZNFV930; Type: Portable Tablet; Serial: 02249

Communication System: UID 0, LTE Band 12; Frequency: 707.5 MHz; Duty Cycle: 1:1
Medium: 750 Body Medium parameters used (interpolated):
 $f = 707.5 \text{ MHz}$; $\sigma = 0.925 \text{ S/m}$; $\epsilon_r = 55.181$; $\rho = 1000 \text{ kg/m}^3$
Phantom section: Flat Section ; Space: 0.0 cm

Test Date: 06-23-2015; Ambient Temp: 23.8°C; Tissue Temp: 22.0°C

Probe: ES3DV3 - SN3331; ConvF(6.12, 6.12, 6.12); Calibrated: 8/20/2014;
Sensor-Surface: 3mm (Mechanical Surface Detection)
Electronics: DAE4 Sn1333; Calibrated: 10/31/2014
Phantom: SAM Main ; Type: QD000P40CC; Serial: TP 1114
Measurement SW: DASY52, Version 52.8 (8); SEMCAD X Version 14.6.10 (7331)

**Mode: LTE Band 12, Body SAR, Back side, Mid.ch,
10 MHz Bandwidth, QPSK, 1 RB, 0 RB Offset**

Area Scan (15x19x1): Measurement grid: dx=15mm, dy=15mm
Zoom Scan (5x5x7)/Cube 0: Measurement grid: dx=8mm, dy=8mm, dz=5mm
Reference Value = 27.55 V/m; Power Drift = 0.00 dB
Peak SAR (extrapolated) = 1.15 W/kg
SAR(1 g) = 0.607 W/kg

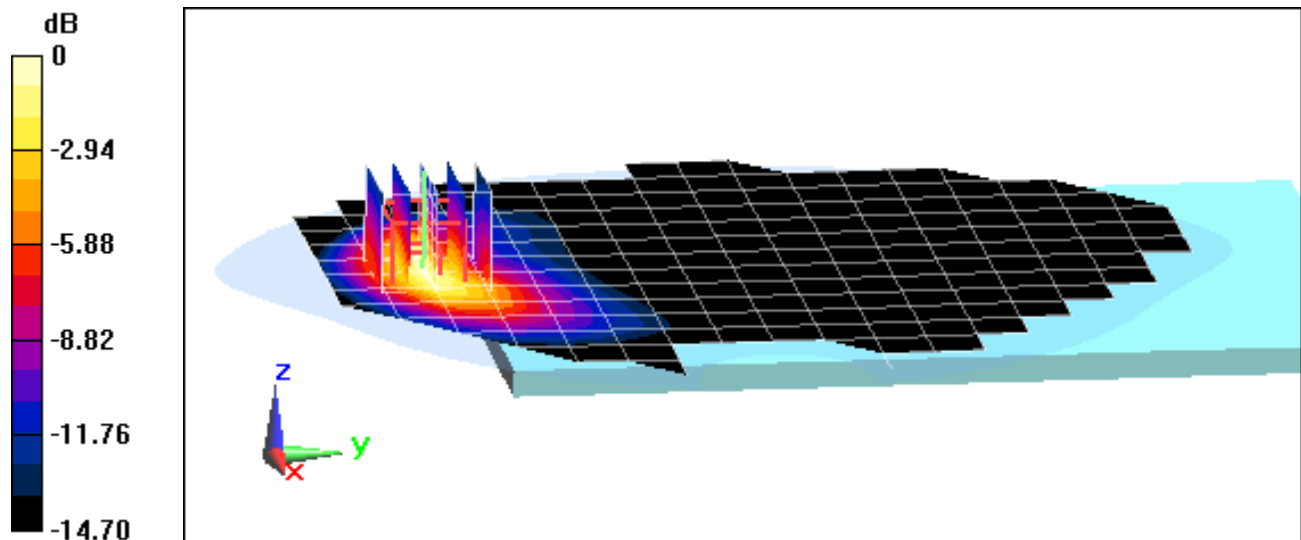

0 dB = 0.797 W/kg = -0.99 dBW/kg

PCTEST ENGINEERING LABORATORY, INC.

DUT: ZNFV930; Type: Portable Tablet; Serial: 02256

Communication System: UID 0, LTE Band 5 (Cell.); Frequency: 836.5 MHz; Duty Cycle: 1:1
Medium: 835 Body Medium parameters used (interpolated):
 $f = 836.5 \text{ MHz}$; $\sigma = 0.999 \text{ S/m}$; $\epsilon_r = 52.966$; $\rho = 1000 \text{ kg/m}^3$
Phantom section: Flat Section ; Space: 0.0 cm

Test Date: 06-19-2015; Ambient Temp: 23.5°C; Tissue Temp: 22.5°C

Probe: ES3DV3 - SN3331; ConvF(6.14, 6.14, 6.14); Calibrated: 8/20/2014;
Sensor-Surface: 3mm (Mechanical Surface Detection)
Electronics: DAE4 Sn1333; Calibrated: 10/31/2014
Phantom: SAM Main ; Type: QD000P40CC; Serial: TP 1114
Measurement SW: DASY52, Version 52.8 (8); SEMCAD X Version 14.6.10 (7331)

**Mode: LTE Band 5 (Cell.), Body SAR, Top Edge, Mid.ch,
10 MHz Bandwidth, QPSK, 25 RB, 25 RB Offset**

Area Scan (11x15x1): Measurement grid: dx=5mm, dy=15mm
Zoom Scan (5x5x7)/Cube 0: Measurement grid: dx=8mm, dy=8mm, dz=5mm
Reference Value = 28.41 V/m; Power Drift = 0.04 dB
Peak SAR (extrapolated) = 1.38 W/kg
SAR(1 g) = 0.710 W/kg

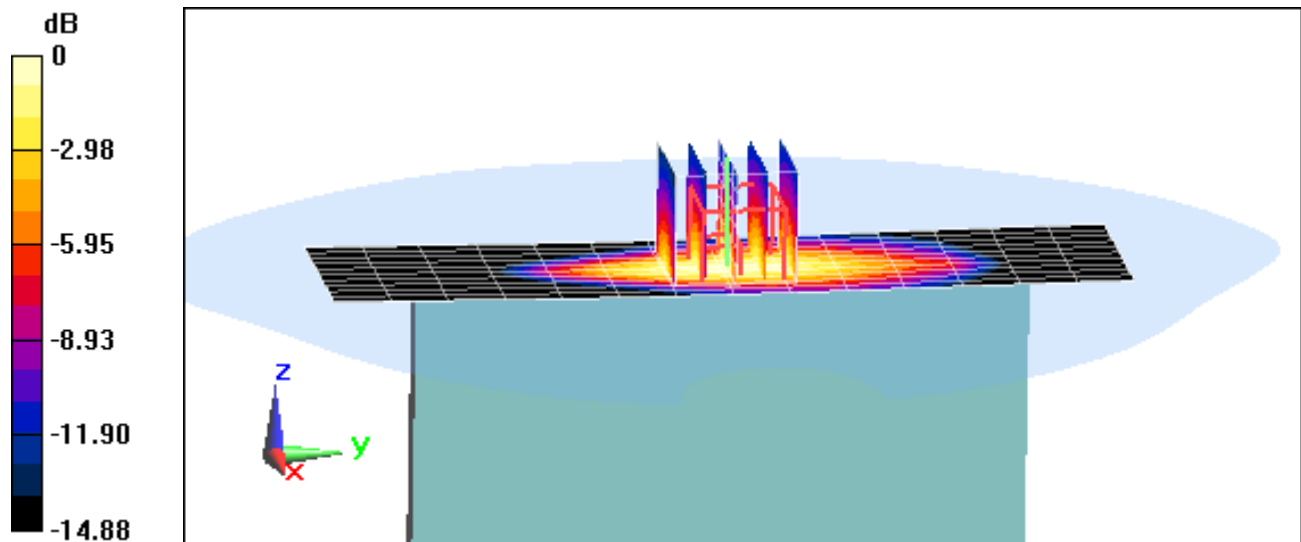

0 dB = 0.919 W/kg = -0.37 dBW/kg

PCTEST ENGINEERING LABORATORY, INC.

DUT: ZNFV930; Type: Portable Tablet; Serial: 02223

Communication System: UID 0, LTE Band 4 (AWS); Frequency: 1732.5 MHz; Duty Cycle: 1:1
Medium: 1750 Body Medium parameters used (interpolated):
 $f = 1732.5 \text{ MHz}$; $\sigma = 1.451 \text{ S/m}$; $\epsilon_r = 52.32$; $\rho = 1000 \text{ kg/m}^3$
Phantom section: Flat Section ; Space: 1.4 cm

Test Date: 06-18-2015; Ambient Temp: 23.1°C; Tissue Temp: 22.6°C

Probe: ES3DV3 - SN3334; ConvF(4.94, 4.94, 4.94); Calibrated: 12/16/2014;
Sensor-Surface: 3mm (Mechanical Surface Detection)
Electronics: DAE4 Sn1415; Calibrated: 12/12/2014
Phantom: ELI v5.0; Type: QDOVA001BB; Serial: 1158
Measurement SW: DASY52, Version 52.8 (8); SEMCAD X Version 14.6.10 (7331)

**Mode: LTE Band 4 (AWS), Body SAR, Right Edge, Mid.ch,
20 MHz Bandwidth, QPSK, 1 RB, 0 RB Offset**

Area Scan (12x20x1): Measurement grid: dx=5mm, dy=15mm
Zoom Scan (5x5x7)/Cube 0: Measurement grid: dx=8mm, dy=8mm, dz=5mm
Reference Value = 19.99 V/m; Power Drift = 0.02 dB
Peak SAR (extrapolated) = 0.969 W/kg
SAR(1 g) = 0.576 W/kg

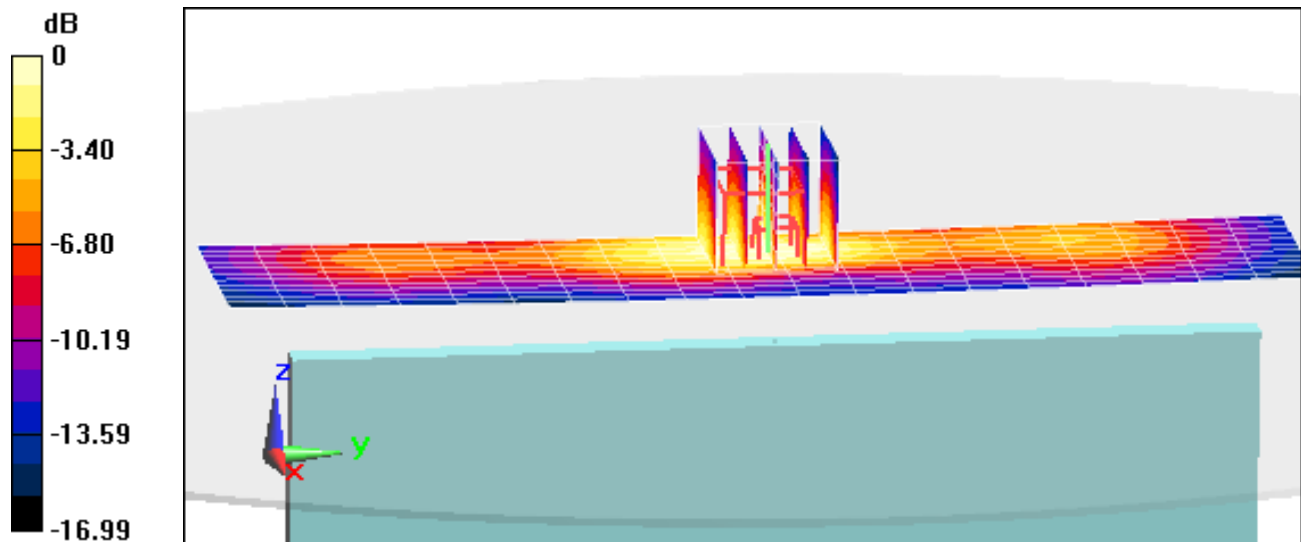

0 dB = 0.645 W/kg = -1.90 dBW/kg

PCTEST ENGINEERING LABORATORY, INC.

DUT: ZNFV930; Type: Portable Tablet; Serial: 02231

Communication System: UID 0, LTE Band 2 (PCS); Frequency: 1860 MHz; Duty Cycle: 1:1

Medium: 1900 Body Medium parameters used:

$f = 1860 \text{ MHz}$; $\sigma = 1.507 \text{ S/m}$; $\epsilon_r = 51.343$; $\rho = 1000 \text{ kg/m}^3$

Phantom section: Flat Section ; Space: 1.2 cm

Test Date: 06-17-2015; Ambient Temp: 24.3°C; Tissue Temp: 22.8°C

Probe: ES3DV3 - SN3331; ConvF(4.73, 4.73, 4.73); Calibrated: 8/20/2014;

Sensor-Surface: 3mm (Mechanical Surface Detection)

Electronics: DAE4 Sn1333; Calibrated: 10/31/2014

Phantom: SAM Sub ; Type: QD000P40CC; Serial: TP:1357

Measurement SW: DASY52, Version 52.8 (8); SEMCAD X Version 14.6.10 (7331)

**Mode: LTE Band 2 (PCS), Body SAR, Back side, Low.ch,
20 MHz Bandwidth, QPSK, 50 RB, 0 RB Offset**

Area Scan (13x19x1): Measurement grid: dx=15mm, dy=15mm

Zoom Scan (5x5x7)/Cube 0: Measurement grid: dx=8mm, dy=8mm, dz=5mm

Reference Value = 23.90 V/m; Power Drift = -0.02 dB

Peak SAR (extrapolated) = 1.26 W/kg

SAR(1 g) = 0.724 W/kg

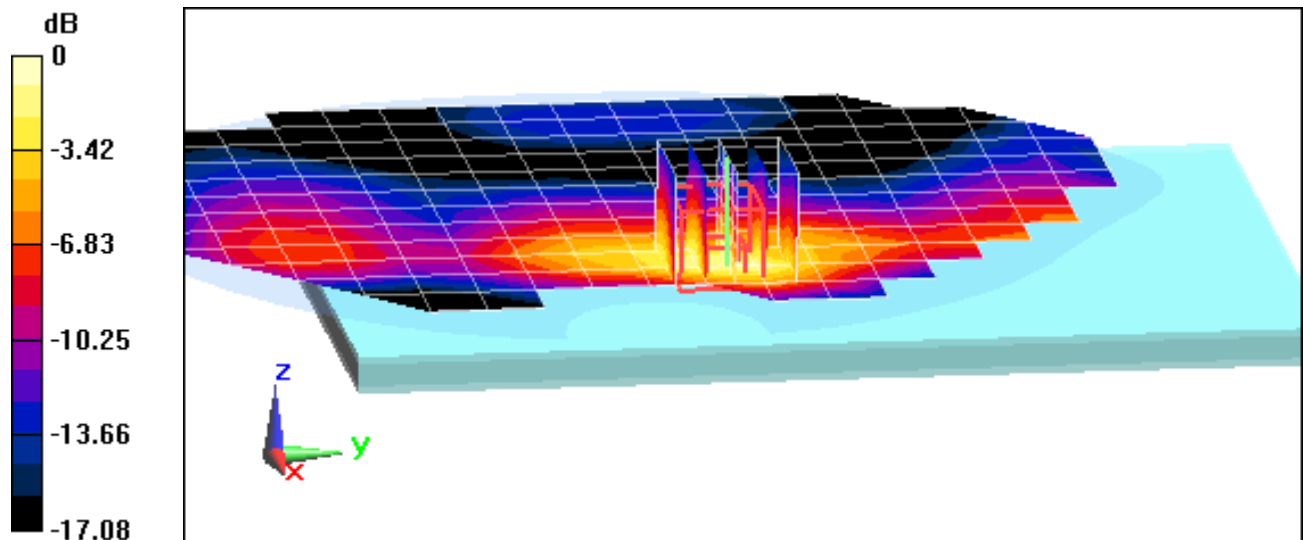

0 dB = 0.904 W/kg = -0.44 dBW/kg

PCTEST ENGINEERING LABORATORY, INC.

DUT: ZNFV930; Type: Portable Tablet; Serial: 02249

Communication System: UID 0, LTE Band 7; Frequency: 2560 MHz; Duty Cycle: 1:1
Medium: 2450 Body Medium parameters used (interpolated):
 $f = 2560 \text{ MHz}$; $\sigma = 2.097 \text{ S/m}$; $\epsilon_r = 51.167$; $\rho = 1000 \text{ kg/m}^3$
Phantom section: Flat Section ; Space: 0.0 cm

Test Date: 06-19-2015; Ambient Temp: 22.3°C; Tissue Temp: 23.5°C

Probe: ES3DV3 - SN3334; ConvF(4.16, 4.16, 4.16); Calibrated: 12/16/2014;
Sensor-Surface: 3mm (Mechanical Surface Detection)
Electronics: DAE4 Sn1415; Calibrated: 12/12/2014
Phantom: ELI v5.0; Type: QDOVA001BB; Serial: 1158
Measurement SW: DASY52, Version 52.8 (8); SEMCAD X Version 14.6.10 (7331)

**Mode: LTE Band 7, Body SAR, Back side, High.ch,
20 MHz Bandwidth, QPSK, 50 RB, 25 RB Offset**

Area Scan (18x24x1): Measurement grid: dx=12mm, dy=12mm
Zoom Scan (7x7x7)/Cube 0: Measurement grid: dx=5mm, dy=5mm, dz=5mm
Reference Value = 21.17 V/m; Power Drift = -0.06 dB
Peak SAR (extrapolated) = 2.15 W/kg
SAR(1 g) = 0.721 W/kg

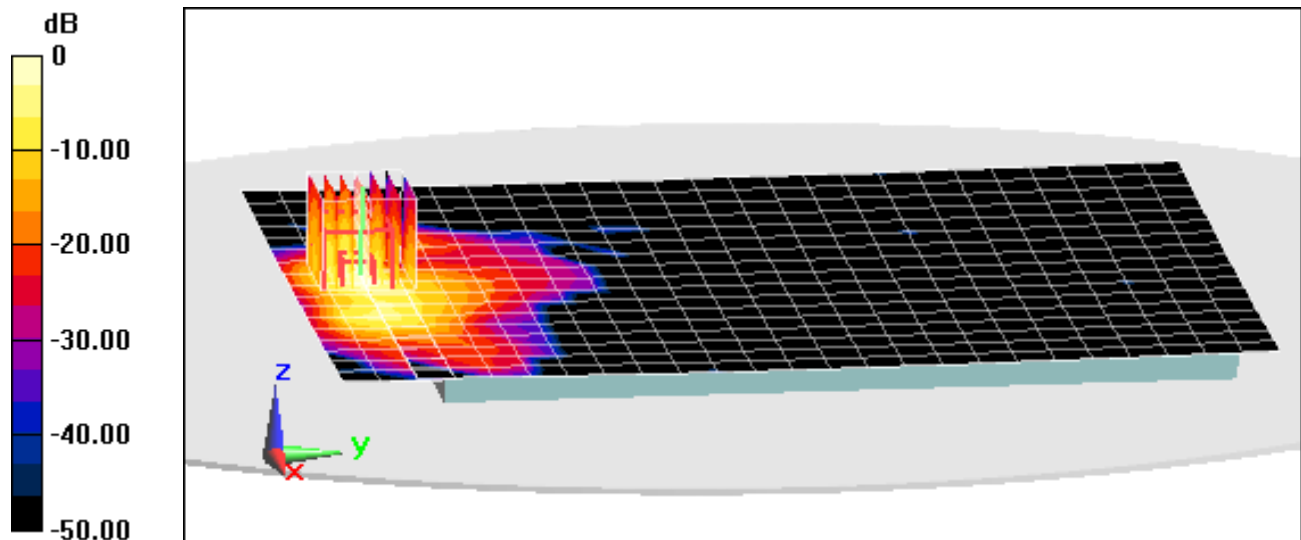

0 dB = 1.08 W/kg = 0.33 dBW/kg

PCTEST ENGINEERING LABORATORY, INC.

DUT: ZNFV930; Type: Portable Tablet; Serial: 02264

Communication System: UID 0, IEEE 802.11b; Frequency: 2462 MHz; Duty Cycle: 1:1
Medium: 2450 Body Medium parameters used (interpolated):
 $f = 2462 \text{ MHz}$; $\sigma = 1.96 \text{ S/m}$; $\epsilon_r = 51.574$; $\rho = 1000 \text{ kg/m}^3$
Phantom section: Flat Section ; Space: 0.0 cm

Test Date: 06-19-2015; Ambient Temp: 22.3°C; Tissue Temp: 23.5°C

Probe: ES3DV3 - SN3334; ConvF(4.28, 4.28, 4.28); Calibrated: 12/16/2014;
Sensor-Surface: 3mm (Mechanical Surface Detection)
Electronics: DAE4 Sn1415; Calibrated: 12/12/2014
Phantom: ELI v5.0; Type: QDOVA001BB; Serial: 1158
Measurement SW: DASY52, Version 52.8 (8); SEMCAD X Version 14.6.10 (7331)

**Mode: IEEE 802.11b, 22 MHz Bandwidth,
Body SAR, Ch 11, 1 Mbps, Back Side**

Area Scan (18x26x1): Measurement grid: dx=12mm, dy=12mm
Zoom Scan (7x7x7)/Cube 0: Measurement grid: dx=5mm, dy=5mm, dz=5mm
Reference Value = 14.79 V/m; Power Drift = -0.01 dB
Peak SAR (extrapolated) = 0.836 W/kg
SAR(1 g) = 0.366 W/kg

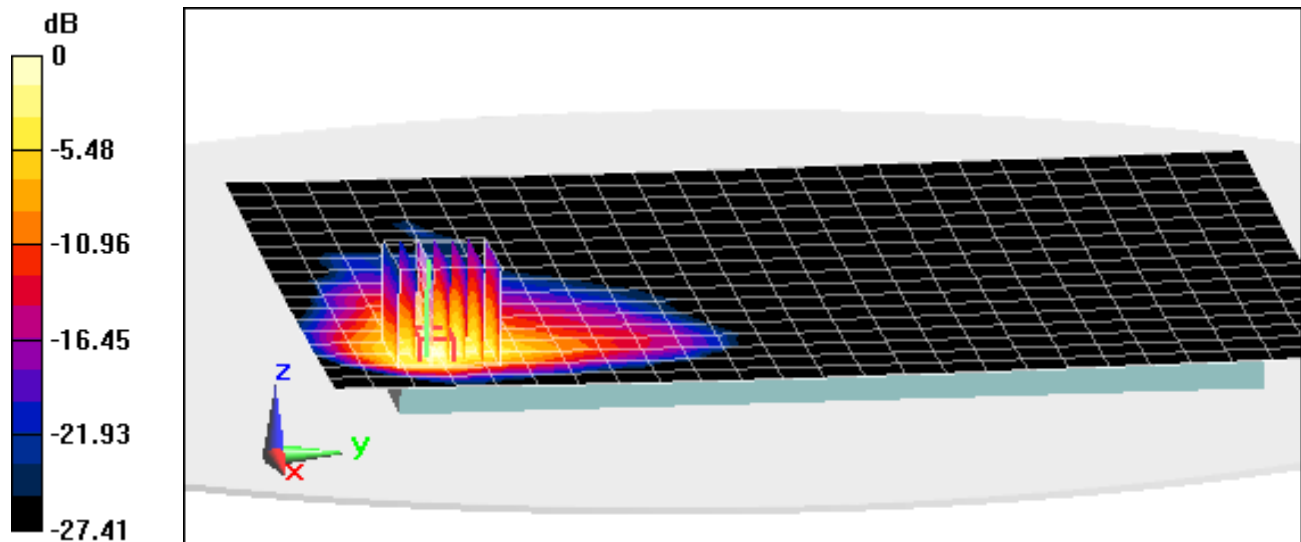

0 dB = 0.490 W/kg = -3.10 dBW/kg

PCTEST ENGINEERING LABORATORY, INC.

DUT: ZNFV930; Type: Portable Tablet; Serial: 02264

Communication System: UID 0, 802.11a 5.2-5.8 GHz Band; Frequency: 5300 MHz; Duty Cycle: 1:1

Medium: 5 GHz Body Medium parameters used:

$f = 5300 \text{ MHz}$; $\sigma = 5.507 \text{ S/m}$; $\epsilon_r = 47.205$; $\rho = 1000 \text{ kg/m}^3$

Phantom section: Flat Section ; Space: 0.0 cm

Test Date: 06-22-2015; Ambient Temp: 23.8°C; Tissue Temp: 21.4°C

Probe: EX3DV4 - SN3914; ConvF(4.33, 4.33, 4.33); Calibrated: 2/10/2015;

Sensor-Surface: 1.4mm (Mechanical Surface Detection)

Electronics: DAE4 Sn1333; Calibrated: 10/31/2014

Phantom: SAM Sub ; Type: QD000P40CC; Serial: TP:1357

Measurement SW: DASY52, Version 52.8 (8); SEMCAD X Version 14.6.10 (7331)

**Mode: IEEE 802.11a, U-NII-2A, 20 MHz Bandwidth,
Body SAR, Ch 60, 6 Mbps, Top Edge**

Area Scan (11x22x1): Measurement grid: dx=5mm, dy=10mm

Zoom Scan (7x7x7)/Cube 0: Measurement grid: dx=4mm, dy=4mm, dz=1.4mm; Graded Ratio=1.4

Reference Value = 11.12 V/m; Power Drift = 0.01 dB

Peak SAR (extrapolated) = 3.10 W/kg

SAR(1 g) = 0.579 W/kg

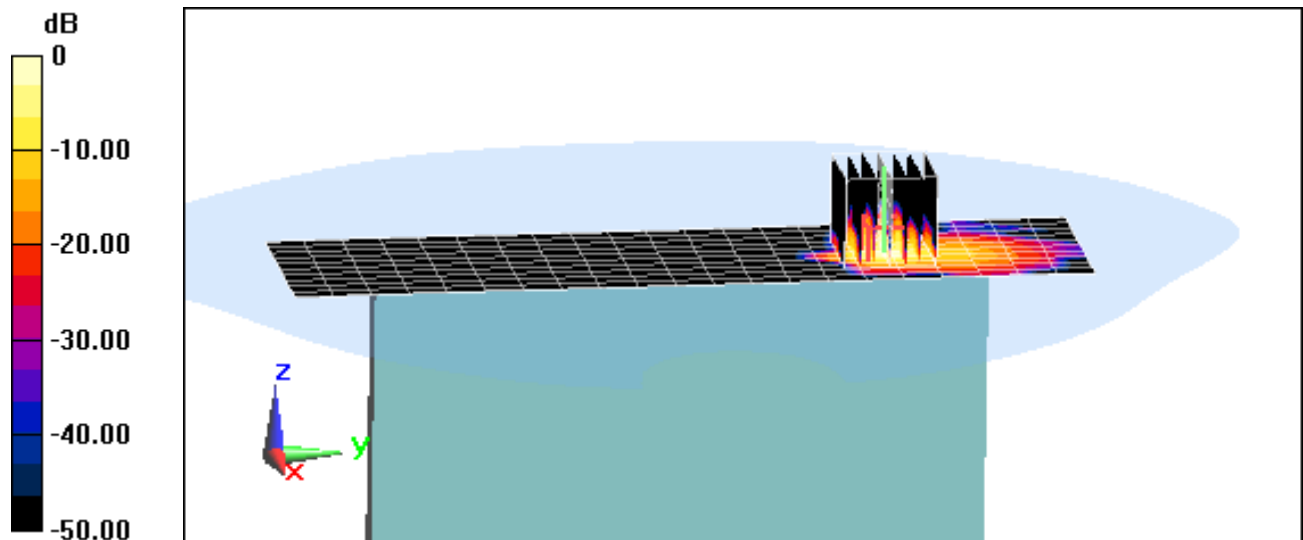

0 dB = 1.89 W/kg = 2.76 dBW/kg

APPENDIX B: SYSTEM VERIFICATION

PCTEST ENGINEERING LABORATORY, INC.

DUT: Dipole 750 MHz; Type: D750V3; Serial: 1046

Communication System: UID 0, CW; Frequency: 750 MHz; Duty Cycle: 1:1

Medium: 750 Body Medium parameters used (interpolated):

$f = 750 \text{ MHz}$; $\sigma = 0.965 \text{ S/m}$; $\epsilon_r = 54.637$; $\rho = 1000 \text{ kg/m}^3$

Phantom section: Flat Section ; Space: 1.5 cm

Test Date: 06-23-2015; Ambient Temp: 23.8°C; Tissue Temp: 22.0°C

Probe: ES3DV3 - SN3331; ConvF(6.12, 6.12, 6.12); Calibrated: 8/20/2014;

Sensor-Surface: 3mm (Mechanical Surface Detection)

Electronics: DAE4 Sn1333; Calibrated: 10/31/2014

Phantom: SAM Main ; Type: QD000P40CC; Serial: TP 1114

Measurement SW: DASY52, Version 52.8 (8); SEMCAD X Version 14.6.10 (7331)

750 MHz System Verification

Area Scan (7x15x1): Measurement grid: dx=15mm, dy=15mm

Zoom Scan (5x5x7)/Cube 0: Measurement grid: dx=8mm, dy=8mm, dz=5mm

Input Power = 23 dBm (200 mW)

Peak SAR (extrapolated) = 2.60 W/kg

SAR(1 g) = 1.77 W/kg

Deviation = 6.76%

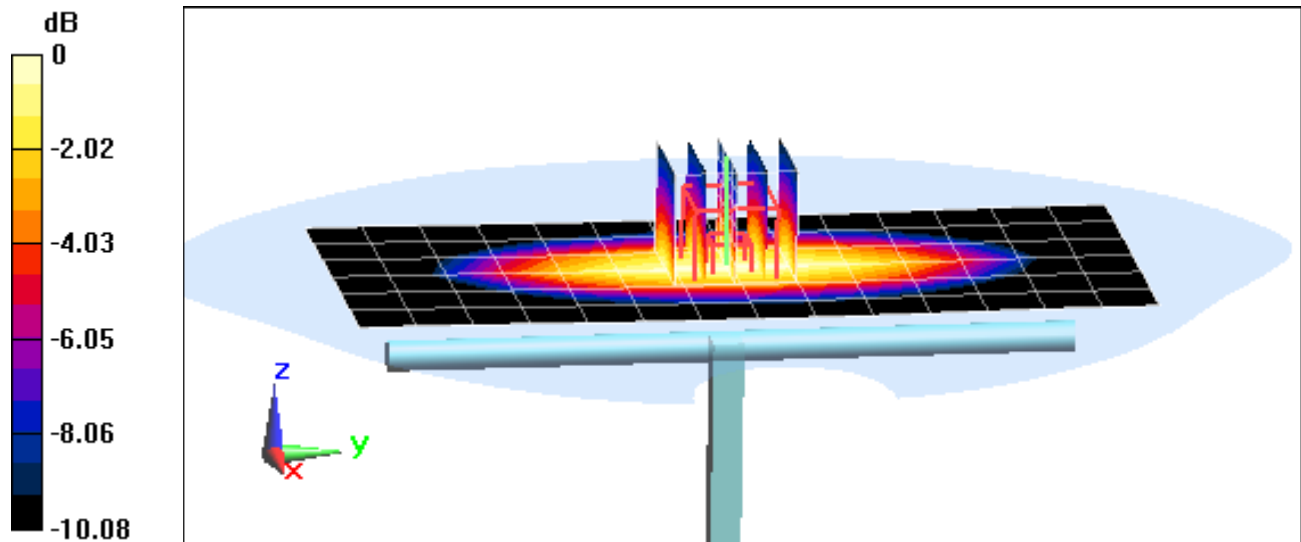

0 dB = 2.07 W/kg = 3.16 dBW/kg

PCTEST ENGINEERING LABORATORY, INC.

DUT: Dipole 835 MHz; Type: D835V2; Serial: 4d119

Communication System: UID 0, CW; Frequency: 835 MHz; Duty Cycle: 1:1

Medium: 835 Body Medium parameters used:

$f = 835 \text{ MHz}$; $\sigma = 0.997 \text{ S/m}$; $\epsilon_r = 52.981$; $\rho = 1000 \text{ kg/m}^3$

Phantom section: Flat Section ; Space: 1.5 cm

Test Date: 06-19-2015; Ambient Temp: 23.5°C; Tissue Temp: 22.5°C

Probe: ES3DV3 - SN3331; ConvF(6.14, 6.14, 6.14); Calibrated: 8/20/2014;

Sensor-Surface: 3mm (Mechanical Surface Detection)

Electronics: DAE4 Sn1333; Calibrated: 10/31/2014

Phantom: SAM Main ; Type: QD000P40CC; Serial: TP 1114

Measurement SW: DASY52, Version 52.8 (8); SEMCAD X Version 14.6.10 (7331)

835 MHz System Verification

Area Scan (7x14x1): Measurement grid: dx=15mm, dy=15mm

Zoom Scan (5x5x7)/Cube 0: Measurement grid: dx=8mm, dy=8mm, dz=5mm

Input Power = 23 dBm (200 mW)

Peak SAR (extrapolated) = 2.95 W/kg

SAR(1 g) = 1.97 W/kg

Deviation = 7.07%

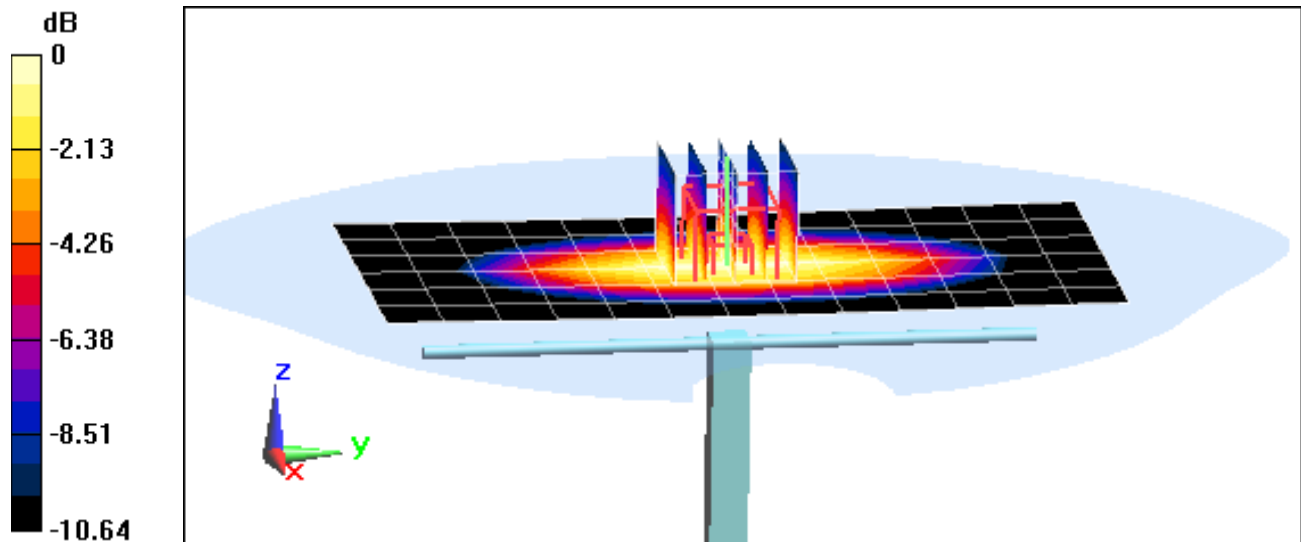

0 dB = 2.31 W/kg = 3.64 dBW/kg

PCTEST ENGINEERING LABORATORY, INC.

DUT: Dipole 1750 MHz; Type: D1765V2; Serial: 1008

Communication System: UID 0, CW; Frequency: 1750 MHz; Duty Cycle: 1:1

Medium: 1750 Body Medium parameters used:

$f = 1750$ MHz; $\sigma = 1.47$ S/m; $\epsilon_r = 52.276$; $\rho = 1000$ kg/m³

Phantom section: Flat Section ; Space: 1.0 cm

Test Date: 06-18-2015; Ambient Temp: 23.1°C; Tissue Temp: 22.6°C

Probe: ES3DV3 - SN3334; ConvF(4.94, 4.94, 4.94); Calibrated: 12/16/2014;

Sensor-Surface: 3mm (Mechanical Surface Detection)

Electronics: DAE4 Sn1415; Calibrated: 12/12/2014

Phantom: ELI v5.0; Type: QDOVA001BB; Serial: 1158

Measurement SW: DASY52, Version 52.8 (8); SEMCAD X Version 14.6.10 (7331)

1750 MHz System Verification

Area Scan (7x9x1): Measurement grid: dx=15mm, dy=15mm

Zoom Scan (5x5x7)/Cube 0: Measurement grid: dx=8mm, dy=8mm, dz=5mm

Input Power = 20 dBm (100 mW)

Peak SAR (extrapolated) = 6.94 W/kg

SAR(1 g) = 3.97 W/kg

Deviation = 4.47%

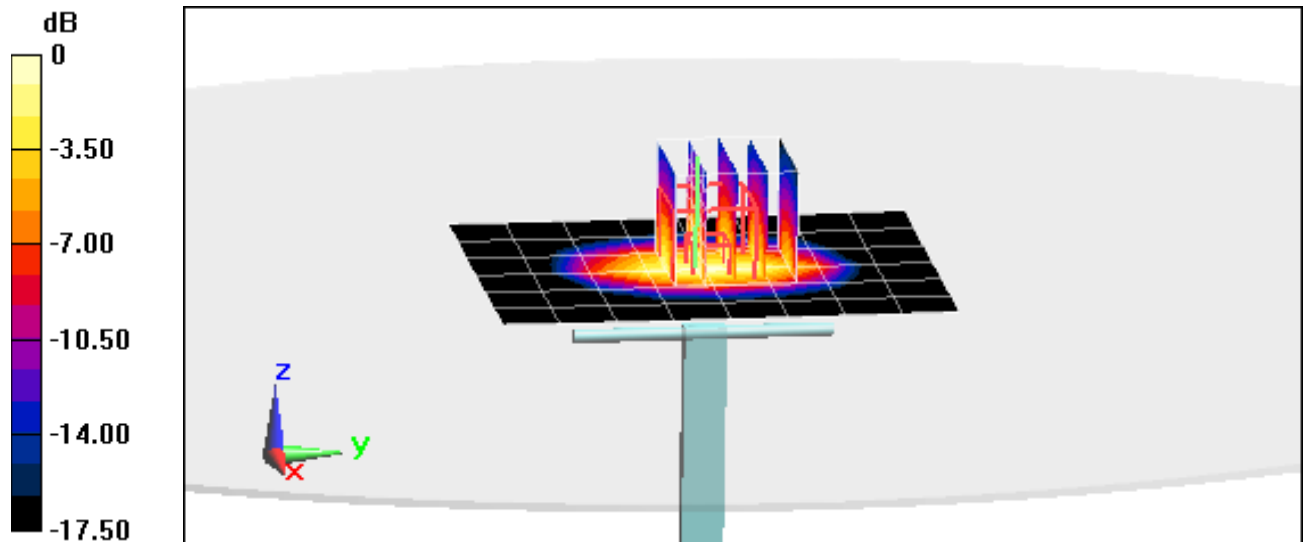

0 dB = 4.85 W/kg = 6.86 dBW/kg

PCTEST ENGINEERING LABORATORY, INC.

DUT: Dipole 1900 MHz; Type: D1900V2; Serial: 5d148

Communication System: UID 0, CW; Frequency: 1900 MHz; Duty Cycle: 1:1
Medium: 1900 Body Medium parameters used (interpolated):
 $f = 1900 \text{ MHz}$; $\sigma = 1.551 \text{ S/m}$; $\epsilon_r = 51.193$; $\rho = 1000 \text{ kg/m}^3$
Phantom section: Flat Section ; Space: 1.0 cm

Test Date: 06-17-2015; Ambient Temp: 24.3°C; Tissue Temp: 22.8°C

Probe: ES3DV3 - SN3331; ConvF(4.73, 4.73, 4.73); Calibrated: 8/20/2014;
Sensor-Surface: 3mm (Mechanical Surface Detection)
Electronics: DAE4 Sn1333; Calibrated: 10/31/2014
Phantom: SAM Sub ; Type: QD000P40CC; Serial: TP:1357
Measurement SW: DASY52, Version 52.8 (8); SEMCAD X Version 14.6.10 (7331)

1900 MHz System Verification

Area Scan (7x10x1): Measurement grid: dx=15mm, dy=15mm

Zoom Scan (5x5x7)/Cube 0: Measurement grid: dx=8mm, dy=8mm, dz=5mm

Input Power = 20 dBm (100 mW)

Peak SAR (extrapolated) = 7.57 W/kg

SAR(1 g) = 4.25 W/kg

Deviation = 5.72%

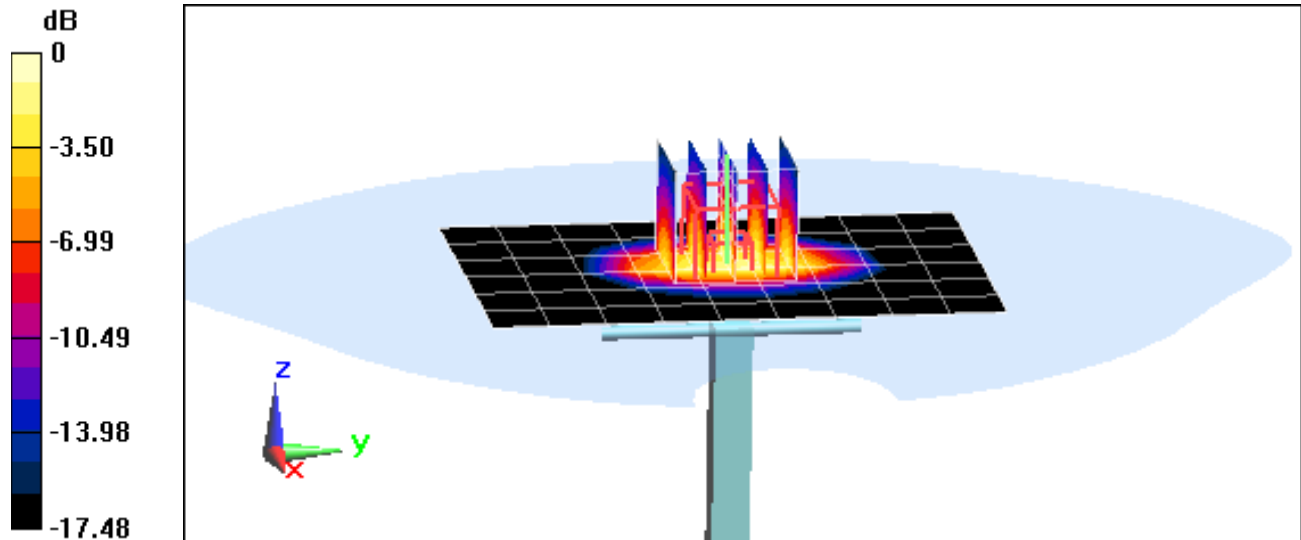

0 dB = 5.39 W/kg = 7.32 dBW/kg

PCTEST ENGINEERING LABORATORY, INC.

DUT: Dipole 2450 MHz; Type: D2450V2; Serial: 882

Communication System: UID 0, CW; Frequency: 2450 MHz; Duty Cycle: 1:1

Medium: 2450 Body Medium parameters used:

$f = 2450$ MHz; $\sigma = 1.944$ S/m; $\epsilon_r = 51.62$; $\rho = 1000$ kg/m³

Phantom section: Flat Section ; Space: 1.0 cm

Test Date: 06-19-2015; Ambient Temp: 22.3°C; Tissue Temp: 23.5°C

Probe: ES3DV3 - SN3334; ConvF(4.28, 4.28, 4.28); Calibrated: 12/16/2014;

Sensor-Surface: 3mm (Mechanical Surface Detection)

Electronics: DAE4 Sn1415; Calibrated: 12/12/2014

Phantom: ELI v5.0; Type: QDOVA001BB; Serial: 1158

Measurement SW: DASY52, Version 52.8 (8); SEMCAD X Version 14.6.10 (7331)

2450 MHz System Verification

Area Scan (8x9x1): Measurement grid: dx=12mm, dy=12mm

Zoom Scan (7x7x7)/Cube 0: Measurement grid: dx=5mm, dy=5mm, dz=5mm

Input Power = 20 dBm (100 mW)

Peak SAR (extrapolated) = 11.5 W/kg

SAR(1 g) = 5.25 W/kg

Deviation = 3.55%

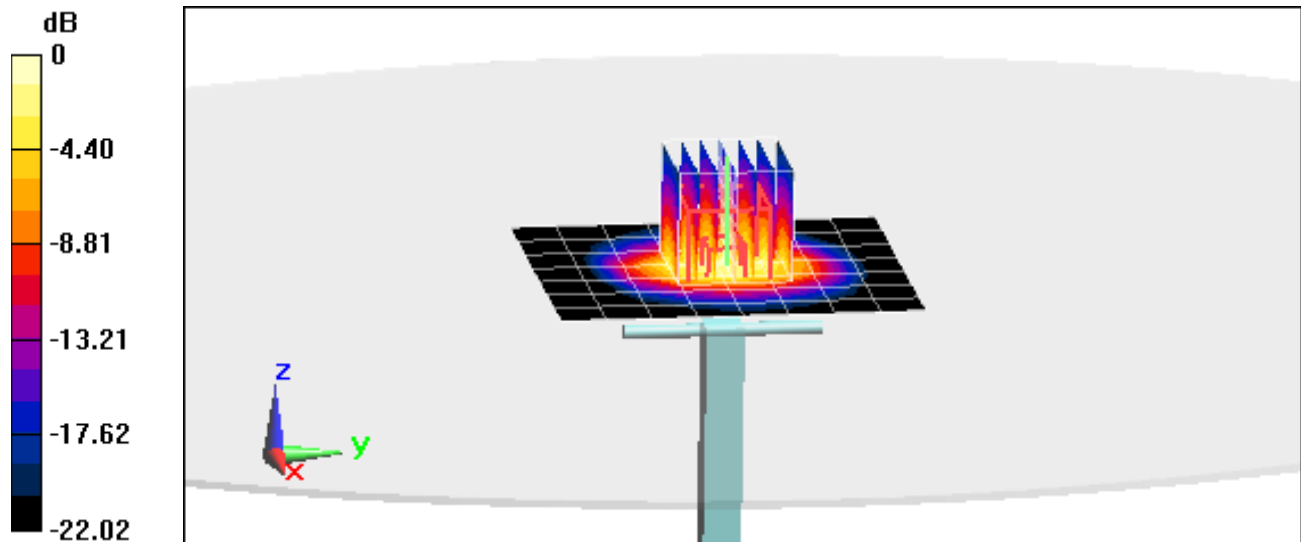

0 dB = 6.84 W/kg = 8.35 dBW/kg

PCTEST ENGINEERING LABORATORY, INC.

DUT: Dipole 2600 MHz; Type: D2600V2; Serial: 1004

Communication System: UID 0, CW; Frequency: 2600 MHz; Duty Cycle: 1:1

Medium: 2450 Body Medium parameters used:

$f = 2600$ MHz; $\sigma = 2.153$ S/m; $\epsilon_r = 51.03$; $\rho = 1000$ kg/m³

Phantom section: Flat Section ; Space: 1.0 cm

Test Date: 06-19-2015; Ambient Temp: 22.3°C; Tissue Temp: 23.5°C

Probe: ES3DV3 - SN3334; ConvF(4.16, 4.16, 4.16); Calibrated: 12/16/2014;

Sensor-Surface: 3mm (Mechanical Surface Detection)

Electronics: DAE4 Sn1415; Calibrated: 12/12/2014

Phantom: ELI v5.0; Type: QDOVA001BB; Serial: 1158

Measurement SW: DASY52, Version 52.8 (8); SEMCAD X Version 14.6.10 (7331)

2600 MHz System Verification

Area Scan (8x9x1): Measurement grid: dx=12mm, dy=12mm

Zoom Scan (7x7x7)/Cube 0: Measurement grid: dx=5mm, dy=5mm, dz=5mm

Input Power = 20 dBm (100 mW)

Peak SAR (extrapolated) = 11.5 W/kg

SAR(1 g) = 5.28 W/kg

Deviation = -6.05%

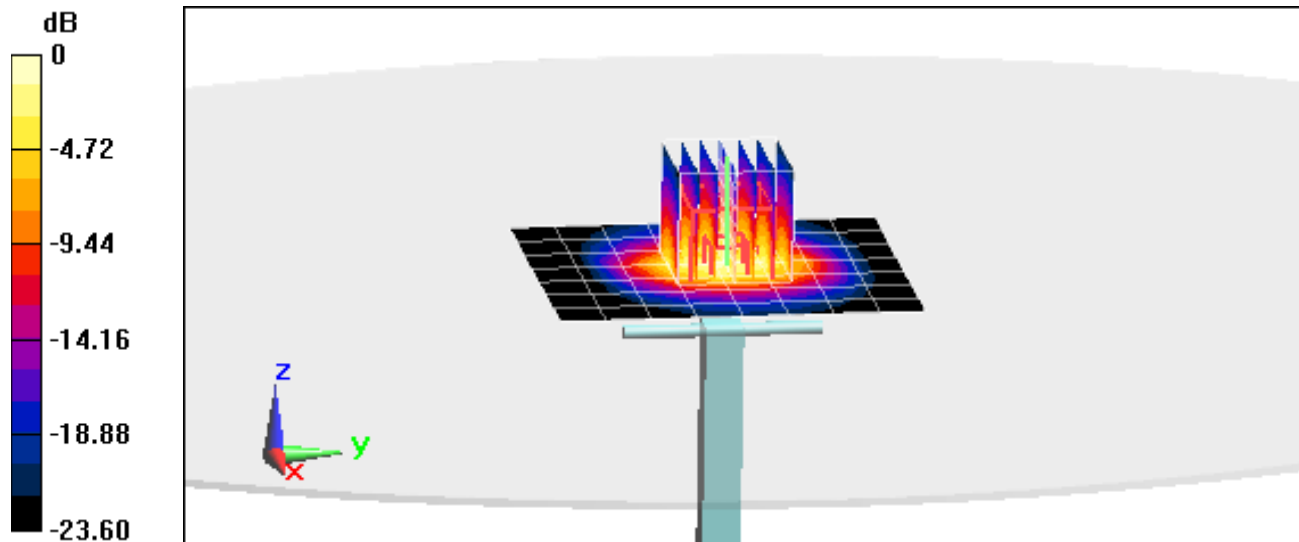

0 dB = 7.06 W/kg = 8.49 dBW/kg

PCTEST ENGINEERING LABORATORY, INC.

DUT: Dipole 5 GHz; Type: D5GHzV2; Serial: 1191

Communication System: UID 0, CW; Frequency: 5300 MHz; Duty Cycle: 1:1

Medium: 5 GHz Body Medium parameters used:

$f = 5300 \text{ MHz}$; $\sigma = 5.507 \text{ S/m}$; $\epsilon_r = 47.205$; $\rho = 1000 \text{ kg/m}^3$

Phantom section: Flat Section ; Space: 1.0 cm

Test Date: 06-22-2015; Ambient Temp: 23.8°C; Tissue Temp: 21.4°C

Probe: EX3DV4 - SN3914; ConvF(4.33, 4.33, 4.33); Calibrated: 2/10/2015;

Sensor-Surface: 1.4mm (Mechanical Surface Detection)

Electronics: DAE4 Sn1333; Calibrated: 10/31/2014

Phantom: SAM Sub ; Type: QD000P40CC; Serial: TP:1357

Measurement SW: DASY52, Version 52.8 (8); SEMCAD X Version 14.6.10 (7331)

5300 MHz System Verification

Area Scan (7x8x1): Measurement grid: dx=10mm, dy=10mm

Zoom Scan (8x8x7)/Cube 0: Measurement grid: dx=4mm, dy=4mm, dz=1.4mm; Graded Ratio=1.4

Input Power = 17 dBm (50 mW)

Peak SAR (extrapolated) = 16.5 W/kg

SAR(1 g) = 3.84 W/kg

Deviation = -3.88%

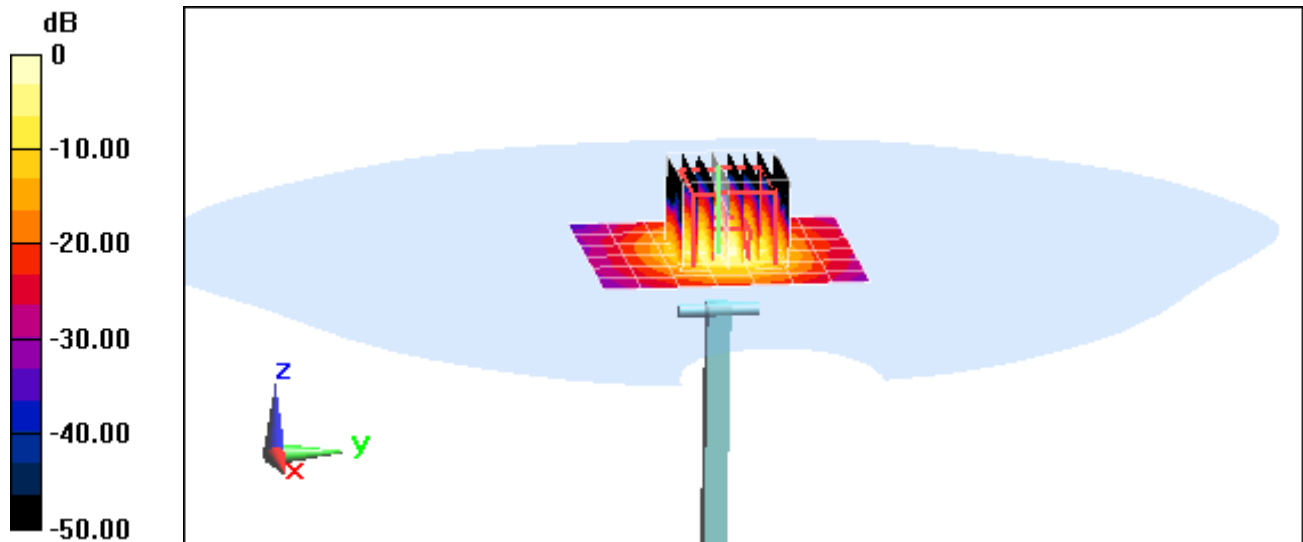

0 dB = 9.07 W/kg = 9.58 dBW/kg

PCTEST ENGINEERING LABORATORY, INC.

DUT: Dipole 5 GHz; Type: D5GHzV2; Serial: 1191

Communication System: UID 0, CW; Frequency: 5500 MHz; Duty Cycle: 1:1

Medium: 5 GHz Body Medium parameters used:

$f = 5500 \text{ MHz}$; $\sigma = 5.752 \text{ S/m}$; $\epsilon_r = 46.978$; $\rho = 1000 \text{ kg/m}^3$

Phantom section: Flat Section ; Space: 1.0 cm

Test Date: 06-22-2015; Ambient Temp: 23.8°C; Tissue Temp: 21.4°C

Probe: EX3DV4 - SN3914; ConvF(3.91, 3.91, 3.91); Calibrated: 2/10/2015;

Sensor-Surface: 1.4mm (Mechanical Surface Detection)

Electronics: DAE4 Sn1333; Calibrated: 10/31/2014

Phantom: SAM Sub ; Type: QD000P40CC; Serial: TP:1357

Measurement SW: DASY52, Version 52.8 (8); SEMCAD X Version 14.6.10 (7331)

5500 MHz System Verification

Area Scan (7x7x1): Measurement grid: dx=10mm, dy=10mm

Zoom Scan (8x8x7)/Cube 0: Measurement grid: dx=4mm, dy=4mm, dz=1.4mm; Graded Ratio=1.4

Input Power = 17 dBm (50 mW)

Peak SAR (extrapolated) = 17.5 W/kg

SAR(1 g) = 4.02 W/kg

Deviation = -3.25%

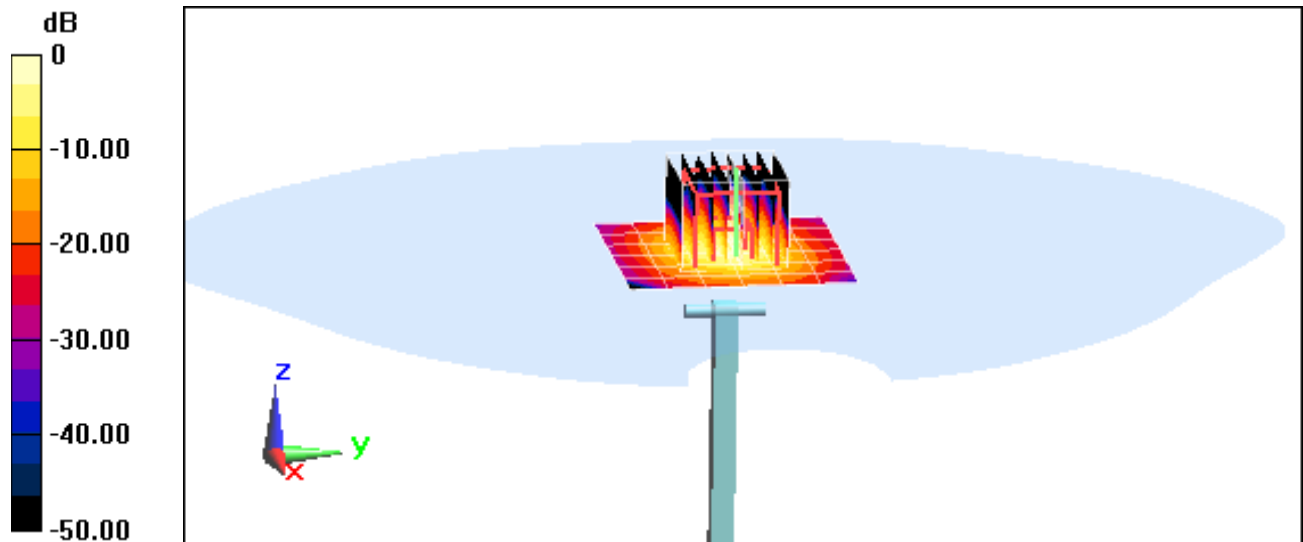

0 dB = 9.84 W/kg = 9.93 dBW/kg

PCTEST ENGINEERING LABORATORY, INC.

DUT: Dipole 5 GHz; Type: D5GHzV2; Serial: 1191

Communication System: UID 0, CW; Frequency: 5800 MHz; Duty Cycle: 1:1

Medium: 5 GHz Body Medium parameters used:

$f = 5800 \text{ MHz}$; $\sigma = 6.151 \text{ S/m}$; $\epsilon_r = 46.492$; $\rho = 1000 \text{ kg/m}^3$

Phantom section: Flat Section ; Space: 1.0 cm

Test Date: 06-22-2015; Ambient Temp: 23.8°C; Tissue Temp: 21.4°C

Probe: EX3DV4 - SN3914; ConvF(4.01, 4.01, 4.01); Calibrated: 2/10/2015;

Sensor-Surface: 1.4mm (Mechanical Surface Detection)

Electronics: DAE4 Sn1333; Calibrated: 10/31/2014

Phantom: SAM Sub ; Type: QD000P40CC; Serial: TP:1357

Measurement SW: DASY52, Version 52.8 (8); SEMCAD X Version 14.6.10 (7331)

5800 MHz System Verification

Area Scan (7x7x1): Measurement grid: dx=10mm, dy=10mm

Zoom Scan (8x8x7)/Cube 0: Measurement grid: dx=4mm, dy=4mm, dz=1.4mm; Graded Ratio=1.4

Input Power = 17 dBm (50 mW)

Peak SAR (extrapolated) = 17.0 W/kg

SAR(1 g) = 3.72 W/kg

Deviation = -4.62%

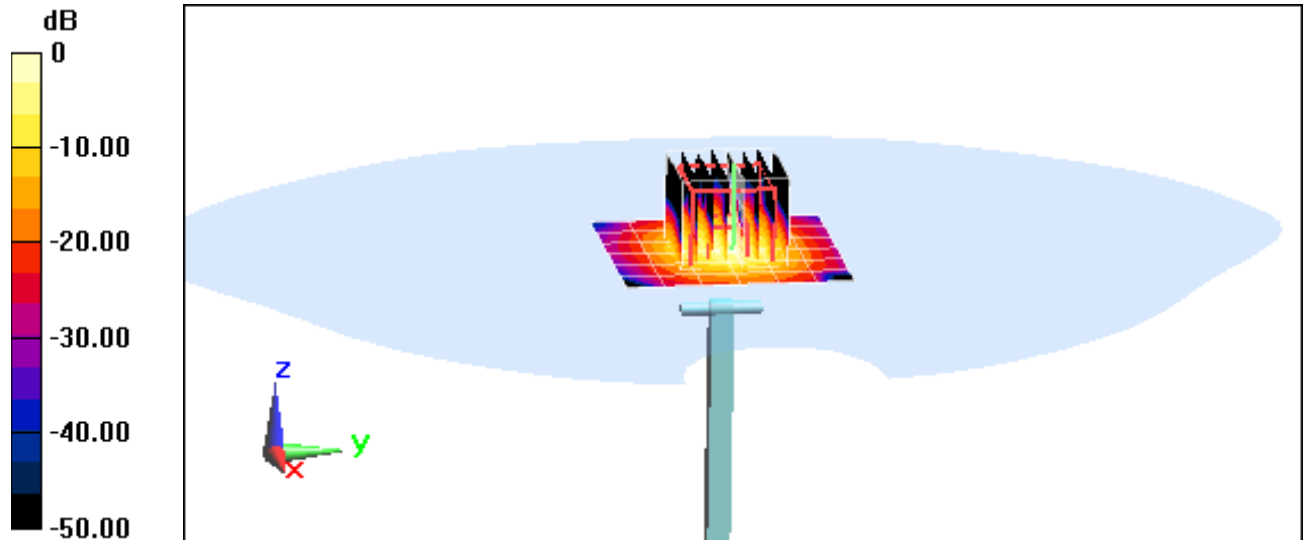

0 dB = 9.45 W/kg = 9.75 dBW/kg

APPENDIX C: PROBE CALIBRATION



Accredited by the Swiss Accreditation Service (SAS)
The Swiss Accreditation Service is one of the signatories to the EA
Multilateral Agreement for the recognition of calibration certificates

Accreditation No.: **SCS 0108**

Client **PC Test**

Certificate No: **D750V3-1046_Feb15**

CALIBRATION CERTIFICATE

Object **D750V3 - SN: 1046**

Calibration procedure(s) **QA CAL-05.v9
Calibration procedure for dipole validation kits above 700 MHz**

*BN ✓
3/6/2015*

Calibration date: **February 19, 2015**

This calibration certificate documents the traceability to national standards, which realize the physical units of measurements (SI).
The measurements and the uncertainties with confidence probability are given on the following pages and are part of the certificate.

All calibrations have been conducted in the closed laboratory facility: environment temperature (22 ± 3)°C and humidity < 70%.

Calibration Equipment used (M&TE critical for calibration)

Primary Standards	ID #	Cal Date (Certificate No.)	Scheduled Calibration
Power meter EPM-442A	GB37480704	07-Oct-14 (No. 217-02020)	Oct-15
Power sensor HP 8481A	US37292783	07-Oct-14 (No. 217-02020)	Oct-15
Power sensor HP 8481A	MY41092317	07-Oct-14 (No. 217-02021)	Oct-15
Reference 20 dB Attenuator	SN: 5058 (20k)	03-Apr-14 (No. 217-01918)	Apr-15
Type-N mismatch combination	SN: 5047.2 / 06327	03-Apr-14 (No. 217-01921)	Apr-15
Reference Probe ES3DV3	SN: 3205	30-Dec-14 (No. ES3-3205_Dec14)	Dec-15
DAE4	SN: 601	18-Aug-14 (No. DAE4-601_Aug14)	Aug-15
Secondary Standards	ID #	Check Date (in house)	Scheduled Check
RF generator R&S SMT-06	100005	04-Aug-99 (in house check Oct-13)	In house check: Oct-16
Network Analyzer HP 8753E	US37390585 S4206	18-Oct-01 (in house check Oct-14)	In house check: Oct-15

	Name	Function	Signature
Calibrated by:	Jeton Kastrati	Laboratory Technician	
Approved by:	Katja Pokovic	Technical Manager	

Issued: February 19, 2015

This calibration certificate shall not be reproduced except in full without written approval of the laboratory.



Accredited by the Swiss Accreditation Service (SAS)
The Swiss Accreditation Service is one of the signatories to the EA
Multilateral Agreement for the recognition of calibration certificates

Accreditation No.: **SCS 0108**

Glossary:

TSL	tissue simulating liquid
ConvF	sensitivity in TSL / NORM x,y,z
N/A	not applicable or not measured

Calibration is Performed According to the Following Standards:

- IEEE Std 1528-2013, "IEEE Recommended Practice for Determining the Peak Spatial-Averaged Specific Absorption Rate (SAR) in the Human Head from Wireless Communications Devices: Measurement Techniques", June 2013
- IEC 62209-1, "Procedure to measure the Specific Absorption Rate (SAR) for hand-held devices used in close proximity to the ear (frequency range of 300 MHz to 3 GHz)", February 2005
- KDB 865664, "SAR Measurement Requirements for 100 MHz to 6 GHz"

Additional Documentation:

- DASY4/5 System Handbook

Methods Applied and Interpretation of Parameters:

- Measurement Conditions:* Further details are available from the Validation Report at the end of the certificate. All figures stated in the certificate are valid at the frequency indicated.
- Antenna Parameters with TSL:* The dipole is mounted with the spacer to position its feed point exactly below the center marking of the flat phantom section, with the arms oriented parallel to the body axis.
- Feed Point Impedance and Return Loss:* These parameters are measured with the dipole positioned under the liquid filled phantom. The impedance stated is transformed from the measurement at the SMA connector to the feed point. The Return Loss ensures low reflected power. No uncertainty required.
- Electrical Delay:* One-way delay between the SMA connector and the antenna feed point. No uncertainty required.
- SAR measured:* SAR measured at the stated antenna input power.
- SAR normalized:* SAR as measured, normalized to an input power of 1 W at the antenna connector.
- SAR for nominal TSL parameters:* The measured TSL parameters are used to calculate the nominal SAR result.

The reported uncertainty of measurement is stated as the standard uncertainty of measurement multiplied by the coverage factor $k=2$, which for a normal distribution corresponds to a coverage probability of approximately 95%.

Measurement Conditions

DASY system configuration, as far as not given on page 1.

DASY Version	DASY5	V52.8.8
Extrapolation	Advanced Extrapolation	
Phantom	Modular Flat Phantom	
Distance Dipole Center - TSL	15 mm	with Spacer
Zoom Scan Resolution	dx, dy, dz = 5 mm	
Frequency	750 MHz ± 1 MHz	

Head TSL parameters

The following parameters and calculations were applied.

	Temperature	Permittivity	Conductivity
Nominal Head TSL parameters	22.0 °C	41.9	0.89 mho/m
Measured Head TSL parameters	(22.0 ± 0.2) °C	41.6 ± 6 %	0.90 mho/m ± 6 %
Head TSL temperature change during test	< 0.5 °C	----	----

SAR result with Head TSL

SAR averaged over 1 cm³ (1 g) of Head TSL	Condition	
SAR measured	250 mW input power	2.03 W/kg
SAR for nominal Head TSL parameters	normalized to 1W	8.04 W/kg ± 17.0 % (k=2)

SAR averaged over 10 cm³ (10 g) of Head TSL	condition	
SAR measured	250 mW input power	1.33 W/kg
SAR for nominal Head TSL parameters	normalized to 1W	5.28 W/kg ± 16.5 % (k=2)

Body TSL parameters

The following parameters and calculations were applied.

	Temperature	Permittivity	Conductivity
Nominal Body TSL parameters	22.0 °C	55.5	0.96 mho/m
Measured Body TSL parameters	(22.0 ± 0.2) °C	53.9 ± 6 %	0.98 mho/m ± 6 %
Body TSL temperature change during test	< 0.5 °C	----	----

SAR result with Body TSL

SAR averaged over 1 cm³ (1 g) of Body TSL	Condition	
SAR measured	250 mW input power	2.12 W/kg
SAR for nominal Body TSL parameters	normalized to 1W	8.29 W/kg ± 17.0 % (k=2)

SAR averaged over 10 cm³ (10 g) of Body TSL	condition	
SAR measured	250 mW input power	1.39 W/kg
SAR for nominal Body TSL parameters	normalized to 1W	5.47 W/kg ± 16.5 % (k=2)

Appendix (Additional assessments outside the scope of SCS0108)

Antenna Parameters with Head TSL

Impedance, transformed to feed point	55.8 Ω + 1.5 j Ω
Return Loss	- 24.9 dB

Antenna Parameters with Body TSL

Impedance, transformed to feed point	51.4 Ω - 1.3 j Ω
Return Loss	- 34.5 dB

General Antenna Parameters and Design

Electrical Delay (one direction)	1.038 ns
----------------------------------	----------

After long term use with 100W radiated power, only a slight warming of the dipole near the feedpoint can be measured.

The dipole is made of standard semirigid coaxial cable. The center conductor of the feeding line is directly connected to the second arm of the dipole. The antenna is therefore short-circuited for DC-signals. On some of the dipoles, small end caps are added to the dipole arms in order to improve matching when loaded according to the position as explained in the "Measurement Conditions" paragraph. The SAR data are not affected by this change. The overall dipole length is still according to the Standard.

No excessive force must be applied to the dipole arms, because they might bend or the soldered connections near the feedpoint may be damaged.

Additional EUT Data

Manufactured by	SPEAG
Manufactured on	September 02, 2011

DASY5 Validation Report for Head TSL

Date: 18.02.2015

Test Laboratory: SPEAG, Zurich, Switzerland

DUT: Dipole 750 MHz; Type: D750V3; Serial: D750V3 - SN: 1046

Communication System: UID 0 - CW; Frequency: 750 MHz

Medium parameters used: $f = 750$ MHz; $\sigma = 0.9$ S/m; $\epsilon_r = 41.6$; $\rho = 1000$ kg/m³

Phantom section: Flat Section

Measurement Standard: DASY5 (IEEE/IEC/ANSI C63.19-2011)

DASY52 Configuration:

- Probe: ES3DV3 - SN3205; ConvF(6.44, 6.44, 6.44); Calibrated: 30.12.2014;
- Sensor-Surface: 3mm (Mechanical Surface Detection)
- Electronics: DAE4 Sn601; Calibrated: 18.08.2014
- Phantom: Flat Phantom 4.9L; Type: QD000P49AA; Serial: 1001
- DASY52 52.8.8(1222); SEMCAD X 14.6.10(7331)

Dipole Calibration for Head Tissue/ $P_{in}=250$ mW, $d=15$ mm/Zoom Scan (7x7x7)/Cube 0:

Measurement grid: $dx=5$ mm, $dy=5$ mm, $dz=5$ mm

Reference Value = 52.99 V/m; Power Drift = 0.01 dB

Peak SAR (extrapolated) = 3.02 W/kg

SAR(1 g) = 2.03 W/kg; SAR(10 g) = 1.33 W/kg

Maximum value of SAR (measured) = 2.37 W/kg

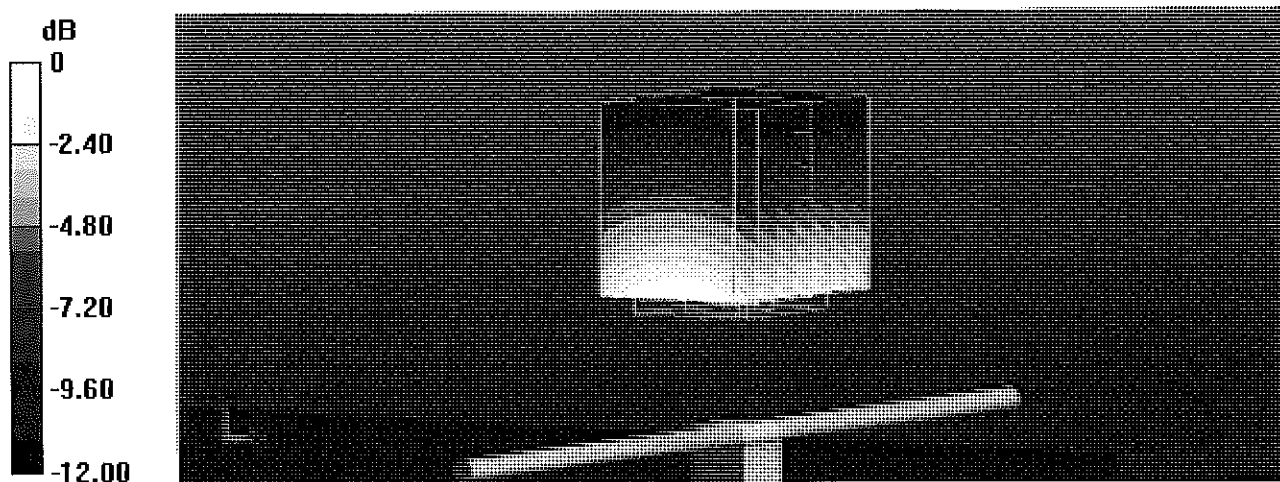

0 dB = 2.37 W/kg = 3.75 dBW/kg

Impedance Measurement Plot for Head TSL

18 Feb 2015 17:03:54

CH1 S11 1 U FS 1: 55.801 Ω 1.5195 μ 322.45 pF 750.000 000 MHz

*
De1
Cor
Avg
16

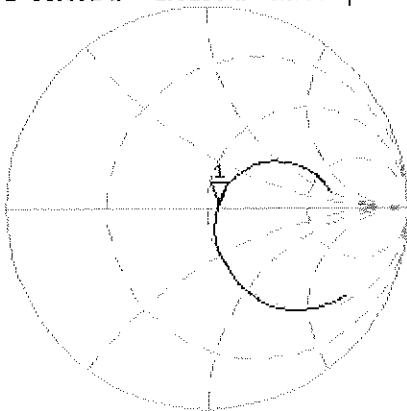

H1d

CH2 S11 LOG 5 dB/REF -20 dB 1:-24.935 dB 750.000 000 MHz

Cor
Avg
16

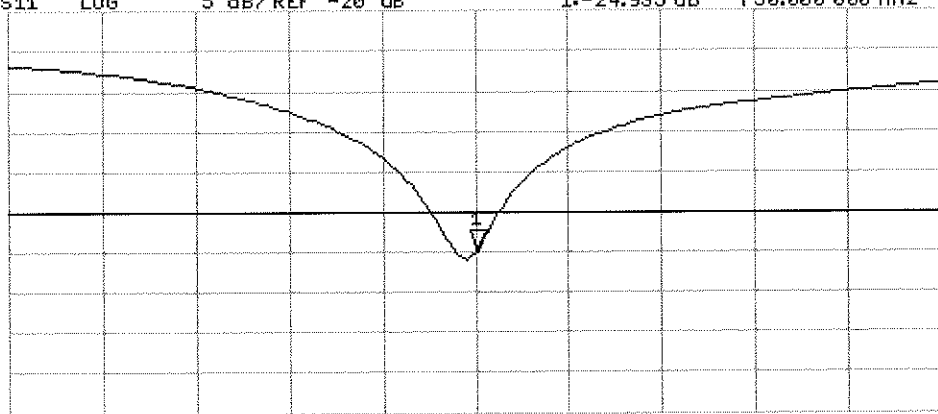

START 550.000 000 MHz

STOP 950.000 000 MHz

H1d

DASY5 Validation Report for Body TSL

Date: 19.02.2015

Test Laboratory: SPEAG, Zurich, Switzerland

DUT: Dipole 750 MHz; Type: D750V3; Serial: D750V3 - SN: 1046

Communication System: UID 0 - CW; Frequency: 750 MHz

Medium parameters used: $f = 750 \text{ MHz}$; $\sigma = 0.98 \text{ S/m}$; $\epsilon_r = 53.9$; $\rho = 1000 \text{ kg/m}^3$

Phantom section: Flat Section

Measurement Standard: DASY5 (IEEE/IEC/ANSI C63.19-2011)

DASY52 Configuration:

- Probe: ES3DV3 - SN3205; ConvF(6.21, 6.21, 6.21); Calibrated: 30.12.2014;
- Sensor-Surface: 3mm (Mechanical Surface Detection)
- Electronics: DAE4 Sn601; Calibrated: 18.08.2014
- Phantom: Flat Phantom 4.9L; Type: QD000P49AA; Serial: 1001
- DASY52 52.8.8(1222); SEMCAD X 14.6.10(7331)

Dipole Calibration for Body Tissue/ $P_{in}=250 \text{ mW}$, $d=15\text{mm}$ /Zoom Scan (7x7x7)/Cube 0:

Measurement grid: $dx=5\text{mm}$, $dy=5\text{mm}$, $dz=5\text{mm}$

Reference Value = 52.00 V/m; Power Drift = -0.04 dB

Peak SAR (extrapolated) = 3.10 W/kg

SAR(1 g) = 2.12 W/kg; SAR(10 g) = 1.39 W/kg

Maximum value of SAR (measured) = 2.46 W/kg

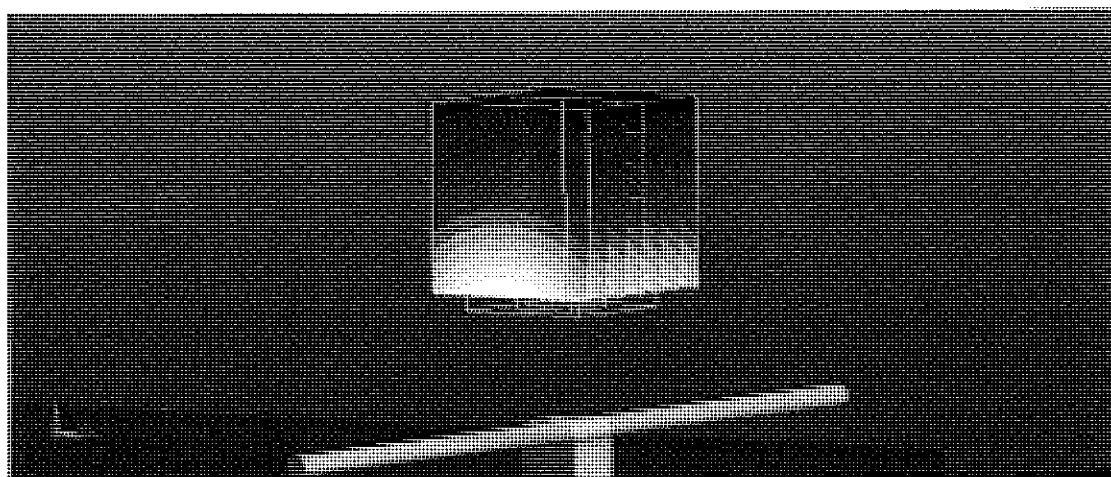
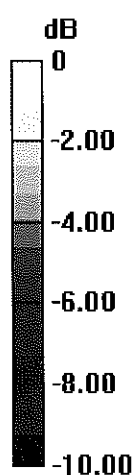

0 dB = 2.46 W/kg = 3.91 dBW/kg

Impedance Measurement Plot for Body TSL

19 Feb 2015 09:09:32

CH1 S11 1 U FS

1: 51.357 Ω -1.2813 Ω 165.62 μ F

750.000 000 MHz

*
De1

CA

Avg
16

H1d

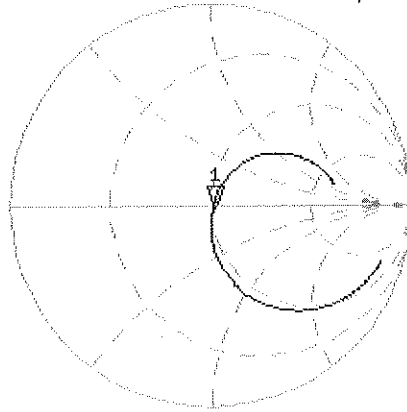

CH2 S11 LOG 5 dB/REF -20 dB 1: -34.515 dB 750.000 000 MHz

CA

Avg
16

H1d

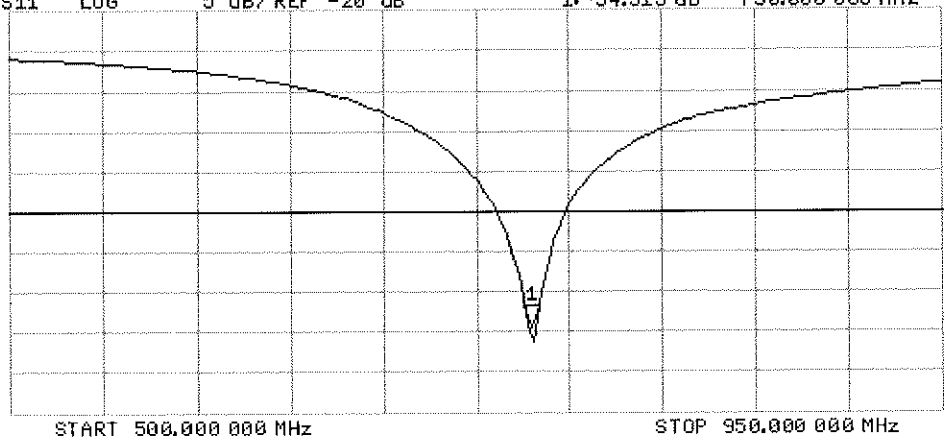



Accredited by the Swiss Accreditation Service (SAS)
The Swiss Accreditation Service is one of the signatories to the EA
Multilateral Agreement for the recognition of calibration certificates

Accreditation No.: **SCS 0108**

Client **PC Test**

Certificate No: **D835V2-4d119_Apr15**

CALIBRATION CERTIFICATE

Object **D835V2 - SN:4d119**

Calibration procedure(s) **QA CAL-05.v9**
Calibration procedure for dipole validation kits above 700 MHz

Calibration date: **April 13, 2015**

RY ✓
4/29/15

This calibration certificate documents the traceability to national standards, which realize the physical units of measurements (SI).
The measurements and the uncertainties with confidence probability are given on the following pages and are part of the certificate.

All calibrations have been conducted in the closed laboratory facility: environment temperature (22 ± 3)°C and humidity < 70%.

Calibration Equipment used (M&TE critical for calibration)

Primary Standards	ID #	Cal Date (Certificate No.)	Scheduled Calibration
Power meter EPM-442A	GB37480704	07-Oct-14 (No. 217-02020)	Oct-15
Power sensor HP 8481A	US37292783	07-Oct-14 (No. 217-02020)	Oct-15
Power sensor HP 8481A	MY41092317	07-Oct-14 (No. 217-02021)	Oct-15
Reference 20 dB Attenuator	SN: 5058 (20k)	01-Apr-15 (No. 217-02131)	Mar-16
Type-N mismatch combination	SN: 5047.2 / 06327	01-Apr-15 (No. 217-02134)	Mar-16
Reference Probe ES3DV3	SN: 3205	30-Dec-14 (No. ES3-3205_Dec14)	Dec-15
DAE4	SN: 601	18-Aug-14 (No. DAE4-601_Aug14)	Aug-15
Secondary Standards	ID #	Check Date (in house)	Scheduled Check
RF generator R&S SMT-06	100005	04-Aug-99 (in house check Oct-13)	In house check: Oct-16
Network Analyzer HP 8753E	US37390585 S4206	18-Oct-01 (in house check Oct-14)	In house check: Oct-15

Calibrated by: **Israe Elnaouq** Name: **Israe Elnaouq** Function: **Laboratory Technician** Signature: *Israe Elnaouq*

Approved by: **Katja Pokovic** Name: **Katja Pokovic** Function: **Technical Manager** Signature: *Katja Pokovic*

Issued: April 13, 2015

This calibration certificate shall not be reproduced except in full without written approval of the laboratory.



Accredited by the Swiss Accreditation Service (SAS)
The Swiss Accreditation Service is one of the signatories to the EA
Multilateral Agreement for the recognition of calibration certificates

Accreditation No.: **SCS 0108**

Glossary:

TSL	tissue simulating liquid
ConvF	sensitivity in TSL / NORM x,y,z
N/A	not applicable or not measured

Calibration is Performed According to the Following Standards:

- IEEE Std 1528-2013, "IEEE Recommended Practice for Determining the Peak Spatial-Averaged Specific Absorption Rate (SAR) in the Human Head from Wireless Communications Devices: Measurement Techniques", June 2013
- IEC 62209-1, "Procedure to measure the Specific Absorption Rate (SAR) for hand-held devices used in close proximity to the ear (frequency range of 300 MHz to 3 GHz)", February 2005
- KDB 865664, "SAR Measurement Requirements for 100 MHz to 6 GHz"

Additional Documentation:

- DASY4/5 System Handbook

Methods Applied and Interpretation of Parameters:

- Measurement Conditions:* Further details are available from the Validation Report at the end of the certificate. All figures stated in the certificate are valid at the frequency indicated.
- Antenna Parameters with TSL:* The dipole is mounted with the spacer to position its feed point exactly below the center marking of the flat phantom section, with the arms oriented parallel to the body axis.
- Feed Point Impedance and Return Loss:* These parameters are measured with the dipole positioned under the liquid filled phantom. The impedance stated is transformed from the measurement at the SMA connector to the feed point. The Return Loss ensures low reflected power. No uncertainty required.
- Electrical Delay:* One-way delay between the SMA connector and the antenna feed point. No uncertainty required.
- SAR measured:* SAR measured at the stated antenna input power.
- SAR normalized:* SAR as measured, normalized to an input power of 1 W at the antenna connector.
- SAR for nominal TSL parameters:* The measured TSL parameters are used to calculate the nominal SAR result.

The reported uncertainty of measurement is stated as the standard uncertainty of measurement multiplied by the coverage factor $k=2$, which for a normal distribution corresponds to a coverage probability of approximately 95%.

Measurement Conditions

DASY system configuration, as far as not given on page 1.

DASY Version	DASY5	V52.8.8
Extrapolation	Advanced Extrapolation	
Phantom	Modular Flat Phantom	
Distance Dipole Center - TSL	15 mm	with Spacer
Zoom Scan Resolution	dx, dy, dz = 5 mm	
Frequency	835 MHz \pm 1 MHz	

Head TSL parameters

The following parameters and calculations were applied.

	Temperature	Permittivity	Conductivity
Nominal Head TSL parameters	22.0 °C	41.5	0.90 mho/m
Measured Head TSL parameters	(22.0 \pm 0.2) °C	40.9 \pm 6 %	0.94 mho/m \pm 6 %
Head TSL temperature change during test	< 0.5 °C	----	----

SAR result with Head TSL

SAR averaged over 1 cm ³ (1 g) of Head TSL	Condition	
SAR measured	250 mW input power	2.43 W/kg
SAR for nominal Head TSL parameters	normalized to 1W	9.38 W/kg \pm 17.0 % (k=2)

SAR averaged over 10 cm ³ (10 g) of Head TSL	condition	
SAR measured	250 mW input power	1.57 W/kg
SAR for nominal Head TSL parameters	normalized to 1W	6.11 W/kg \pm 16.5 % (k=2)

Body TSL parameters

The following parameters and calculations were applied.

	Temperature	Permittivity	Conductivity
Nominal Body TSL parameters	22.0 °C	55.2	0.97 mho/m
Measured Body TSL parameters	(22.0 \pm 0.2) °C	55.4 \pm 6 %	1.01 mho/m \pm 6 %
Body TSL temperature change during test	< 0.5 °C	----	----

SAR result with Body TSL

SAR averaged over 1 cm ³ (1 g) of Body TSL	Condition	
SAR measured	250 mW input power	2.37 W/kg
SAR for nominal Body TSL parameters	normalized to 1W	9.20 W/kg \pm 17.0 % (k=2)

SAR averaged over 10 cm ³ (10 g) of Body TSL	condition	
SAR measured	250 mW input power	1.55 W/kg
SAR for nominal Body TSL parameters	normalized to 1W	6.06 W/kg \pm 16.5 % (k=2)

Appendix (Additional assessments outside the scope of SCS 0108)

Antenna Parameters with Head TSL

Impedance, transformed to feed point	50.2 Ω - 2.2 j Ω
Return Loss	- 33.3 dB

Antenna Parameters with Body TSL

Impedance, transformed to feed point	47.7 Ω - 4.9 j Ω
Return Loss	- 25.1 dB

General Antenna Parameters and Design

Electrical Delay (one direction)	1.386 ns
----------------------------------	----------

After long term use with 100W radiated power, only a slight warming of the dipole near the feedpoint can be measured.

The dipole is made of standard semirigid coaxial cable. The center conductor of the feeding line is directly connected to the second arm of the dipole. The antenna is therefore short-circuited for DC-signals. On some of the dipoles, small end caps are added to the dipole arms in order to improve matching when loaded according to the position as explained in the "Measurement Conditions" paragraph. The SAR data are not affected by this change. The overall dipole length is still according to the Standard.

No excessive force must be applied to the dipole arms, because they might bend or the soldered connections near the feedpoint may be damaged.

Additional EUT Data

Manufactured by	SPEAG
Manufactured on	June 29, 2010

DASY5 Validation Report for Head TSL

Date: 13.04.2015

Test Laboratory: SPEAG, Zurich, Switzerland

DUT: Dipole 835 MHz; Type: D835V2; Serial: D835V2 - SN:4d119

Communication System: UID 0 - CW; Frequency: 835 MHz

Medium parameters used: $f = 835 \text{ MHz}$; $\sigma = 0.94 \text{ S/m}$; $\epsilon_r = 40.9$; $\rho = 1000 \text{ kg/m}^3$

Phantom section: Flat Section

Measurement Standard: DASY5 (IEEE/IEC/ANSI C63.19-2011)

DASY52 Configuration:

- Probe: ES3DV3 - SN3205; ConvF(6.2, 6.2, 6.2); Calibrated: 30.12.2014;
- Sensor-Surface: 3mm (Mechanical Surface Detection)
- Electronics: DAE4 Sn601; Calibrated: 18.08.2014
- Phantom: Flat Phantom 4.9L; Type: QD000P49AA; Serial: 1001
- DASY52 52.8.8(1222); SEMCAD X 14.6.10(7331)

Dipole Calibration for Head Tissue/Pin=250 mW, $d=15\text{mm}$ /Zoom Scan (7x7x7)/Cube 0:

Measurement grid: $dx=5\text{mm}$, $dy=5\text{mm}$, $dz=5\text{mm}$

Reference Value = 56.77 V/m; Power Drift = 0.01 dB

Peak SAR (extrapolated) = 3.64 W/kg

SAR(1 g) = 2.43 W/kg; SAR(10 g) = 1.57 W/kg

Maximum value of SAR (measured) = 2.85 W/kg

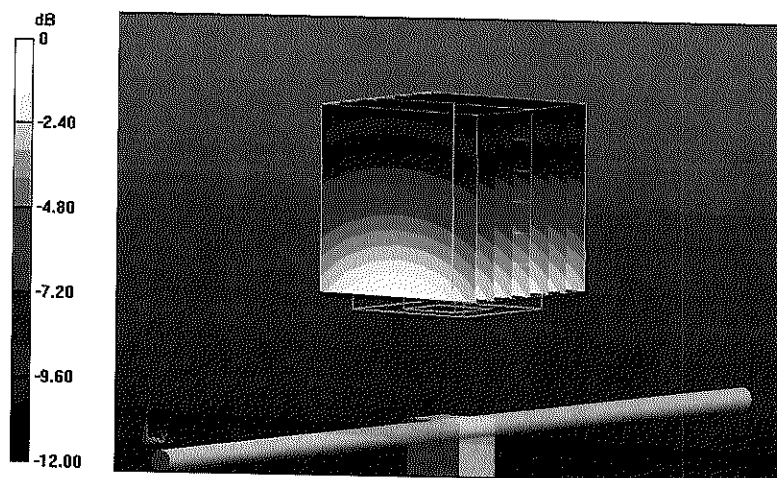

0 dB = 2.85 W/kg = 4.55 dBW/kg

Impedance Measurement Plot for Head TSL

CH1 S11 1 U FS 13 Apr 2015 13:42:59
 2: 50.213 Ω -2.1602 \angle 88.237 μ F 835.000 000 MHz

*
 De1
 CA
 Avg
 16
 H1 d

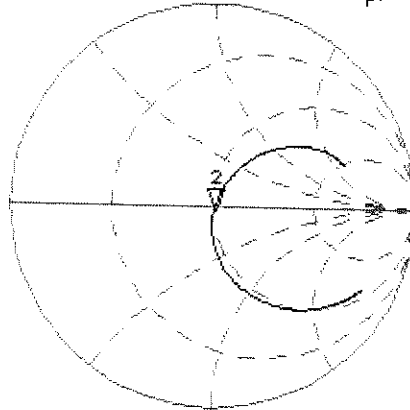

CH2 S11 LOG 5 dB/REF -20 dB 2: -33.275 dB 835.000 000 MHz

CA
 Avg
 16
 H1 d

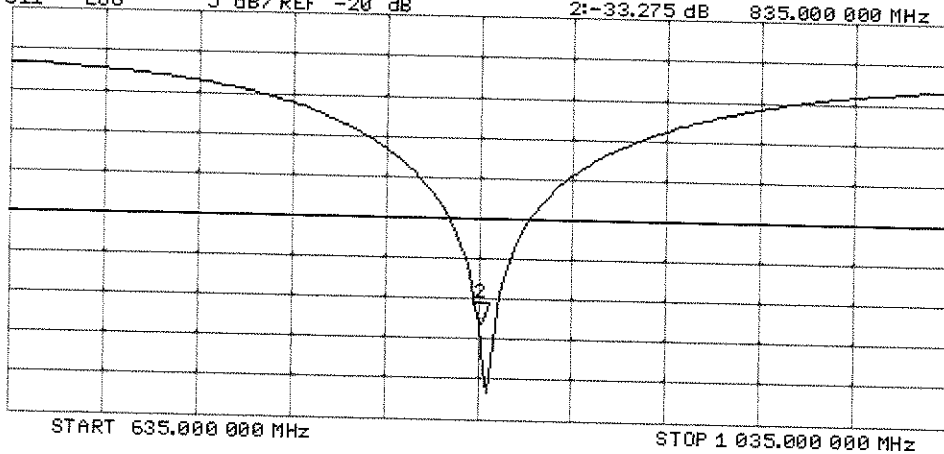

START 635.000 000 MHz STOP 1 035.000 000 MHz

DASY5 Validation Report for Body TSL

Date: 13.04.2015

Test Laboratory: SPEAG, Zurich, Switzerland

DUT: Dipole 835 MHz; Type: D835V2; Serial: D835V2 - SN:4d119

Communication System: UID 0 - CW; Frequency: 835 MHz

Medium parameters used: $f = 835$ MHz; $\sigma = 1.01$ S/m; $\epsilon_r = 55.4$; $\rho = 1000$ kg/m³

Phantom section: Flat Section

Measurement Standard: DASY5 (IEEE/IEC/ANSI C63.19-2011)

DASY52 Configuration:

- Probe: ES3DV3 - SN3205; ConvF(6.17, 6.17, 6.17); Calibrated: 30.12.2014;
- Sensor-Surface: 3mm (Mechanical Surface Detection)
- Electronics: DAE4 Sn601; Calibrated: 18.08.2014
- Phantom: Flat Phantom 4.9L; Type: QD000P49AA; Serial: 1001
- DASY52 52.8.8(1222); SEMCAD X 14.6.10(7331)

Dipole Calibration for Body Tissue/Pin=250 mW, d=15mm/Zoom Scan (7x7x7)/Cube 0:

Measurement grid: dx=5mm, dy=5mm, dz=5mm

Reference Value = 54.44 V/m; Power Drift = -0.06 dB

Peak SAR (extrapolated) = 3.52 W/kg

SAR(1 g) = 2.37 W/kg; SAR(10 g) = 1.55 W/kg

Maximum value of SAR (measured) = 2.77 W/kg

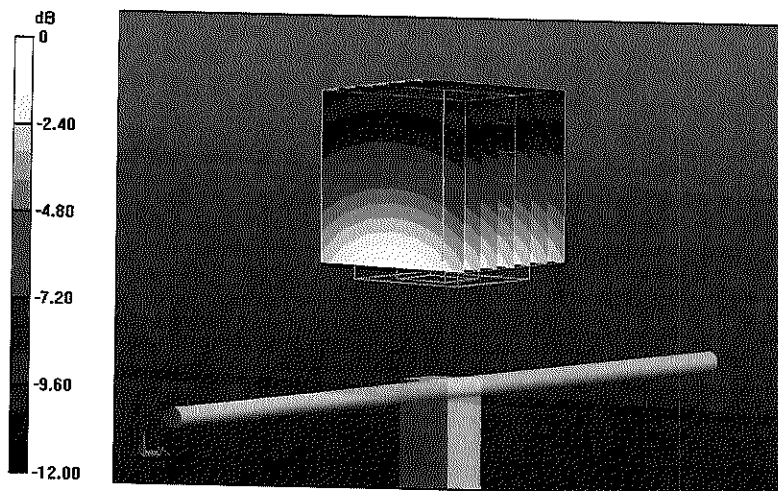

0 dB = 2.77 W/kg = 4.42 dBW/kg

Impedance Measurement Plot for Body TSL

CH1 S11 1 U FS 13 Apr 2015 10:53:33
 2: 47.658 Ω -4.9043 Ω 38.865 pF 835.000 000 MHz

*
Del

Ca

Avg
16

H1 d

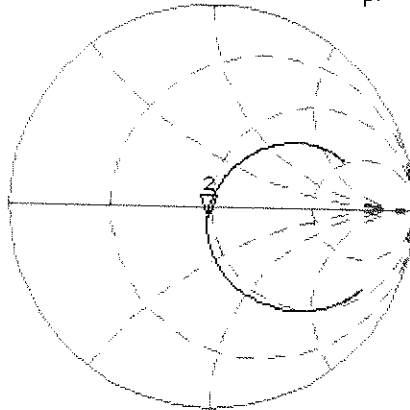

CH2 S11 LOG 5 dB/REF -20 dB 2:-25.104 dB 835.000 000 MHz

Ca

Avg
16

H1 d

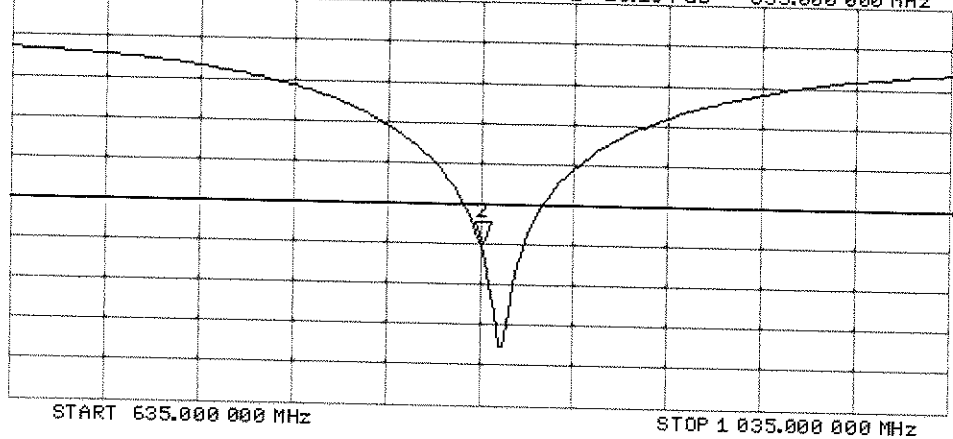



Accredited by the Swiss Accreditation Service (SAS)
The Swiss Accreditation Service is one of the signatories to the EA
Multilateral Agreement for the recognition of calibration certificates

Accreditation No.: **SCS 0108**

Client **PC Test**

Certificate No: **D1765V2-1008_May15**

CALIBRATION CERTIFICATE

Object **D1765V2 - SN: 1008**

Calibration procedure(s) **QA CAL-05.v9
Calibration procedure for dipole validation kits above 700 MHz** CCV
5/28/15

Calibration date: **May 13, 2015**

This calibration certificate documents the traceability to national standards, which realize the physical units of measurements (SI).
The measurements and the uncertainties with confidence probability are given on the following pages and are part of the certificate.

All calibrations have been conducted in the closed laboratory facility: environment temperature (22 ± 3)°C and humidity < 70%.

Calibration Equipment used (M&TE critical for calibration)

Primary Standards	ID #	Cal Date (Certificate No.)	Scheduled Calibration
Power meter EPM-442A	GB37480704	07-Oct-14 (No. 217-02020)	Oct-15
Power sensor HP 8481A	US37292783	07-Oct-14 (No. 217-02020)	Oct-15
Power sensor HP 8481A	MY41092317	07-Oct-14 (No. 217-02021)	Oct-15
Reference 20 dB Attenuator	SN: 5058 (20k)	01-Apr-15 (No. 217-02131)	Mar-16
Type-N mismatch combination	SN: 5047.2 / 06327	01-Apr-15 (No. 217-02134)	Mar-16
Reference Probe ES3DV3	SN: 3205	30-Dec-14 (No. ES3-3205_Dec14)	Dec-15
DAE4	SN: 601	18-Aug-14 (No. DAE4-601_Aug14)	Aug-15
Secondary Standards	ID #	Check Date (in house)	Scheduled Check
RF generator R&S SMT-06	100005	04-Aug-99 (in house check Oct-13)	In house check: Oct-16
Network Analyzer HP 8753E	US37390585 S4206	18-Oct-01 (in house check Oct-14)	In house check: Oct-15

Calibrated by: **Michael Weber** Laboratory Technician Signature
M. Weber

Approved by: **Katja Pokovic** Technical Manager Signature
K. Pokovic

Issued: May 15, 2015

This calibration certificate shall not be reproduced except in full without written approval of the laboratory.



Accredited by the Swiss Accreditation Service (SAS)

The Swiss Accreditation Service is one of the signatories to the EA
Multilateral Agreement for the recognition of calibration certificates

Accreditation No.: **SCS 0108**

Glossary:

TSL	tissue simulating liquid
ConvF	sensitivity in TSL / NORM x,y,z
N/A	not applicable or not measured

Calibration is Performed According to the Following Standards:

- IEEE Std 1528-2013, "IEEE Recommended Practice for Determining the Peak Spatial-Averaged Specific Absorption Rate (SAR) in the Human Head from Wireless Communications Devices: Measurement Techniques", June 2013
- IEC 62209-1, "Procedure to measure the Specific Absorption Rate (SAR) for hand-held devices used in close proximity to the ear (frequency range of 300 MHz to 3 GHz)", February 2005
- KDB 865664, "SAR Measurement Requirements for 100 MHz to 6 GHz"

Additional Documentation:

- DASY4/5 System Handbook

Methods Applied and Interpretation of Parameters:

- Measurement Conditions:** Further details are available from the Validation Report at the end of the certificate. All figures stated in the certificate are valid at the frequency indicated.
- Antenna Parameters with TSL:** The dipole is mounted with the spacer to position its feed point exactly below the center marking of the flat phantom section, with the arms oriented parallel to the body axis.
- Feed Point Impedance and Return Loss:** These parameters are measured with the dipole positioned under the liquid filled phantom. The impedance stated is transformed from the measurement at the SMA connector to the feed point. The Return Loss ensures low reflected power. No uncertainty required.
- Electrical Delay:** One-way delay between the SMA connector and the antenna feed point. No uncertainty required.
- SAR measured:** SAR measured at the stated antenna input power.
- SAR normalized:** SAR as measured, normalized to an input power of 1 W at the antenna connector.
- SAR for nominal TSL parameters:** The measured TSL parameters are used to calculate the nominal SAR result.

The reported uncertainty of measurement is stated as the standard uncertainty of measurement multiplied by the coverage factor $k=2$, which for a normal distribution corresponds to a coverage probability of approximately 95%.

Measurement Conditions

DASY system configuration, as far as not given on page 1.

DASY Version	DASY5	V52.8.8
Extrapolation	Advanced Extrapolation	
Phantom	Modular Flat Phantom	
Distance Dipole Center - TSL	10 mm	with Spacer
Zoom Scan Resolution	dx, dy, dz = 5 mm	
Frequency	1750 MHz ± 1 MHz	

Head TSL parameters

The following parameters and calculations were applied.

	Temperature	Permittivity	Conductivity
Nominal Head TSL parameters	22.0 °C	40.1	1.38 mho/m
Measured Head TSL parameters	(22.0 ± 0.2) °C	39.0 ± 6 %	1.37 mho/m ± 6 %
Head TSL temperature change during test	< 0.5 °C	----	----

SAR result with Head TSL

SAR averaged over 1 cm ³ (1 g) of Head TSL	Condition	
SAR measured	250 mW input power	9.45 W/kg
SAR for nominal Head TSL parameters	normalized to 1W	37.7 W/kg ± 17.0 % (k=2)

SAR averaged over 10 cm ³ (10 g) of Head TSL	condition	
SAR measured	250 mW input power	5.02 W/kg
SAR for nominal Head TSL parameters	normalized to 1W	20.1 W/kg ± 16.5 % (k=2)

Body TSL parameters

The following parameters and calculations were applied.

	Temperature	Permittivity	Conductivity
Nominal Body TSL parameters	22.0 °C	53.4	1.50 mho/m
Measured Body TSL parameters	(22.0 ± 0.2) °C	51.5 ± 6 %	1.49 mho/m ± 6 %
Body TSL temperature change during test	< 0.5 °C	----	----

SAR result with Body TSL

SAR averaged over 1 cm ³ (1 g) of Body TSL	Condition	
SAR measured	250 mW input power	9.55 W/kg
SAR for nominal Body TSL parameters	normalized to 1W	38.0 W/kg ± 17.0 % (k=2)

SAR averaged over 10 cm ³ (10 g) of Body TSL	condition	
SAR measured	250 mW input power	5.12 W/kg
SAR for nominal Body TSL parameters	normalized to 1W	20.4 W/kg ± 16.5 % (k=2)

Appendix (Additional assessments outside the scope of SCS 0108)

Antenna Parameters with Head TSL

Impedance, transformed to feed point	48.5 Ω - 4.6 j Ω
Return Loss	- 26.2 dB

Antenna Parameters with Body TSL

Impedance, transformed to feed point	44.8 Ω - 5.3 j Ω
Return Loss	- 22.1 dB

General Antenna Parameters and Design

Electrical Delay (one direction)	1.211 ns
----------------------------------	----------

After long term use with 100W radiated power, only a slight warming of the dipole near the feedpoint can be measured.

The dipole is made of standard semirigid coaxial cable. The center conductor of the feeding line is directly connected to the second arm of the dipole. The antenna is therefore short-circuited for DC-signals. On some of the dipoles, small end caps are added to the dipole arms in order to improve matching when loaded according to the position as explained in the "Measurement Conditions" paragraph. The SAR data are not affected by this change. The overall dipole length is still according to the Standard.

No excessive force must be applied to the dipole arms, because they might bend or the soldered connections near the feedpoint may be damaged.

Additional EUT Data

Manufactured by	SPEAG
Manufactured on	October 06, 2005

DASY5 Validation Report for Head TSL

Date: 13.05.2015

Test Laboratory: SPEAG, Zurich, Switzerland

DUT: Dipole 1765 MHz; Type: D1765V2; Serial: D1765V2 - SN: 1008

Communication System: UID 0 - CW; Frequency: 1750 MHz

Medium parameters used: $f = 1750$ MHz; $\sigma = 1.37$ S/m; $\epsilon_r = 39$; $\rho = 1000$ kg/m³

Phantom section: Flat Section

Measurement Standard: DASY5 (IEEE/IEC/ANSI C63.19-2007)

DASY52 Configuration:

- Probe: ES3DV3 - SN3205; ConvF(5.2, 5.2, 5.2); Calibrated: 30.12.2014;
- Sensor-Surface: 3mm (Mechanical Surface Detection)
- Electronics: DAE4 Sn601; Calibrated: 18.08.2014
- Phantom: Flat Phantom 5.0 (front); Type: QD000P50AA; Serial: 1001
- DASY52 52.8.8(1222); SEMCAD X 14.6.10(7331)

Dipole Calibration for Head Tissue/Pin=250 mW, d=10mm/Zoom Scan (7x7x7)/Cube 0:

Measurement grid: dx=5mm, dy=5mm, dz=5mm

Reference Value = 96.56 V/m; Power Drift = 0.00 dB

Peak SAR (extrapolated) = 17.0 W/kg

SAR(1 g) = 9.45 W/kg; SAR(10 g) = 5.02 W/kg

Maximum value of SAR (measured) = 11.9 W/kg

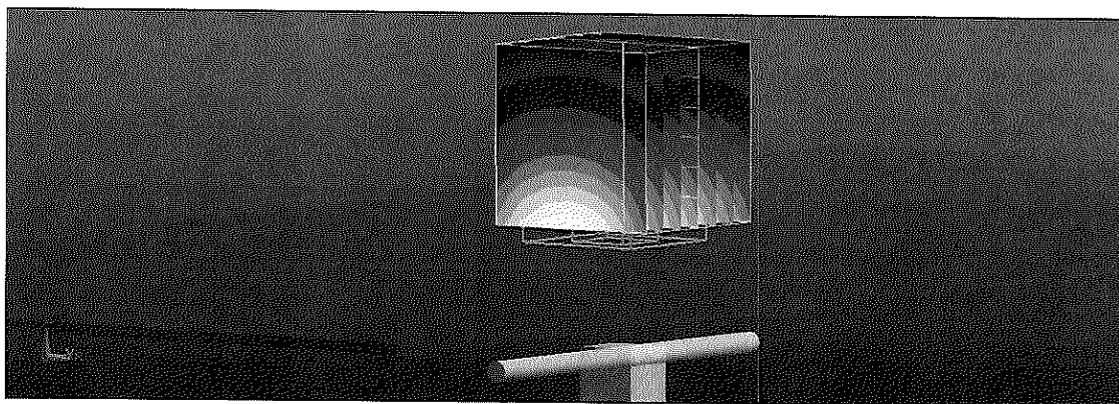
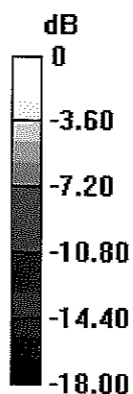

0 dB = 11.9 W/kg = 10.76 dBW/kg

Impedance Measurement Plot for Head TSL

CH1 S11 1 U FS 13 May 2015 09:57:41
1: 48.541 Ω -4.5820 Ω 19.848 μ F 1 750.000 000 MHz

*
De1
Ca
Avg
16
H1d

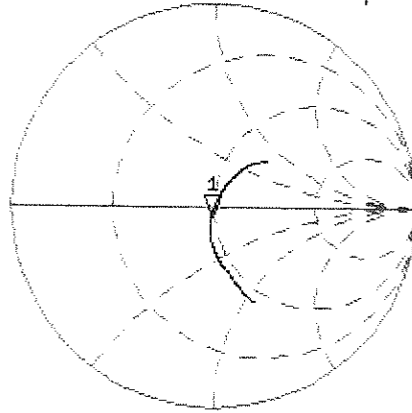

CH2 S11 LOG 5 dB/REF -20 dB 1:-26.240 dB 1 750.000 000 MHz

De1
Ca
Avg
16
H1d

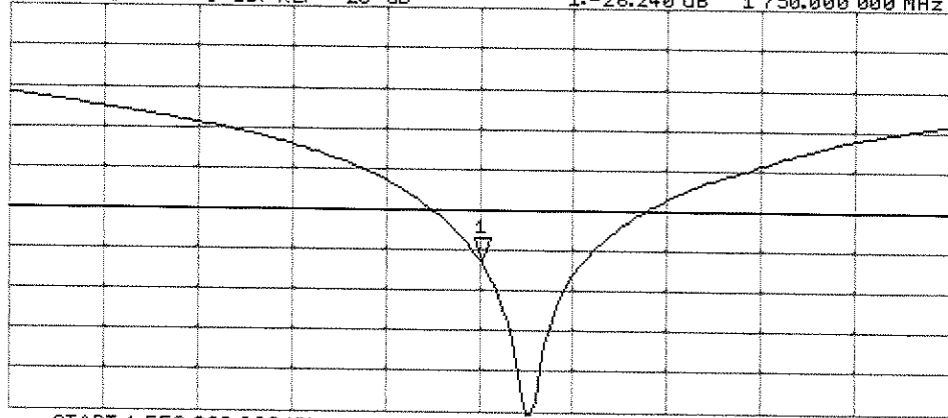

START 1 550.000 000 MHz STOP 1 950.000 000 MHz

DASY5 Validation Report for Body TSL

Date: 13.05.2015

Test Laboratory: SPEAG, Zurich, Switzerland

DUT: Dipole 1765 MHz; Type: D1765V2; Serial: D1765V2 - SN: 1008

Communication System: UID 0 - CW; Frequency: 1750 MHz

Medium parameters used: $f = 1750$ MHz; $\sigma = 1.49$ S/m; $\epsilon_r = 51.5$; $\rho = 1000$ kg/m³

Phantom section: Flat Section

Measurement Standard: DASY5 (IEEE/IEC/ANSI C63.19-2007)

DASY52 Configuration:

- Probe: ES3DV3 - SN3205; ConvF(4.88, 4.88, 4.88); Calibrated: 30.12.2014;
- Sensor-Surface: 3mm (Mechanical Surface Detection)
- Electronics: DAE4 Sn601; Calibrated: 18.08.2014
- Phantom: Flat Phantom 5.0 (back); Type: QD000P50AA; Serial: 1002
- DASY52 52.8.8(1222); SEMCAD X 14.6.10(7331)

Dipole Calibration for Body Tissue/Pin=250 mW, d=10mm/Zoom Scan (7x7x7)/Cube 0:

Measurement grid: dx=5mm, dy=5mm, dz=5mm

Reference Value = 93.70 V/m; Power Drift = -0.00 dB

Peak SAR (extrapolated) = 16.5 W/kg

SAR(1 g) = 9.55 W/kg; SAR(10 g) = 5.12 W/kg

Maximum value of SAR (measured) = 12.0 W/kg

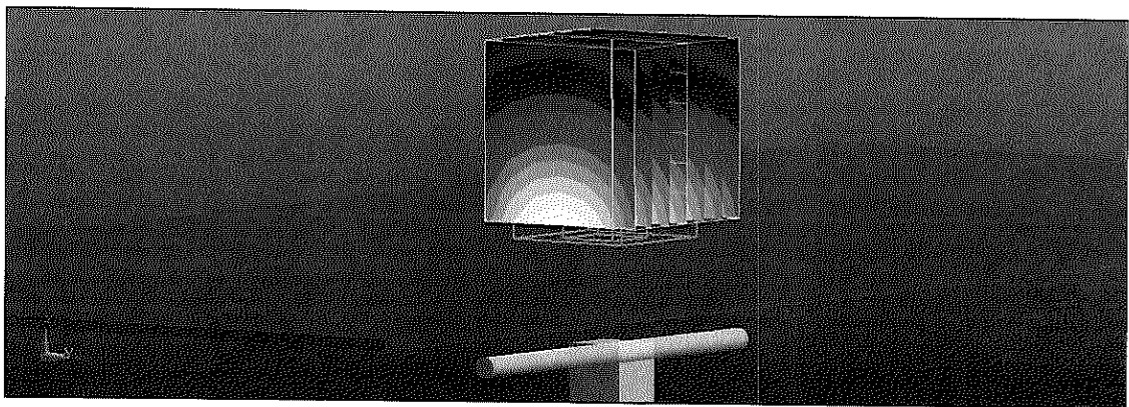
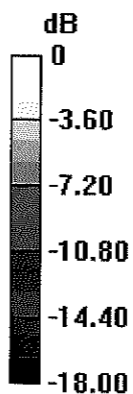

0 dB = 12.0 W/kg = 10.79 dBW/kg

Impedance Measurement Plot for Body TSL

13 May 2015 09:57:07
[CH1] S11 1 U FS 1: 44.771 Ω -5.3477 Ω 17.007 pF 1 750.000 000 MHz

*
Del
CA
Avg
16
H1d

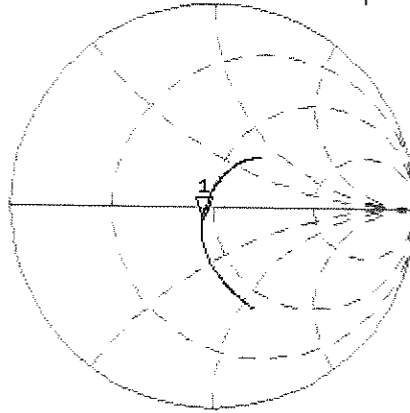

CH2 S11 LOG 5 dB/REF -20 dB 1: -22.073 dB 1 750.000 000 MHz

Del
CA
Avg
16
H1d

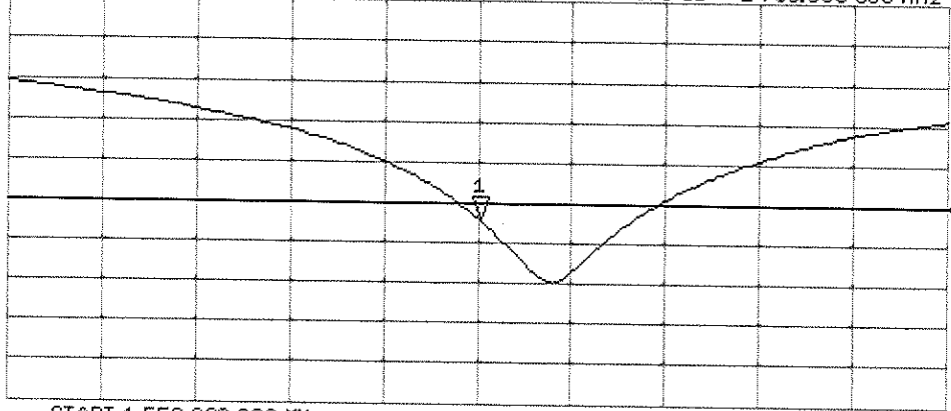

START 1 550.000 000 MHz

STOP 1 950.000 000 MHz



Accredited by the Swiss Accreditation Service (SAS)
The Swiss Accreditation Service is one of the signatories to the EA
Multilateral Agreement for the recognition of calibration certificates

Accreditation No.: **SCS 0108**

Client **PC Test**

Certificate No: **D1900V2-5d148_Feb15**

CALIBRATION CERTIFICATE

Object **D1900V2 - SN: 5d148**

Calibration procedure(s) **QA CAL-05.v9
Calibration procedure for dipole validation kits above 700 MHz**

CC ✓
3/6/15

Calibration date: **February 18, 2015**

This calibration certificate documents the traceability to national standards, which realize the physical units of measurements (SI).
The measurements and the uncertainties with confidence probability are given on the following pages and are part of the certificate.

All calibrations have been conducted in the closed laboratory facility: environment temperature (22 ± 3)°C and humidity < 70%.

Calibration Equipment used (M&TE critical for calibration)

Primary Standards	ID #	Cal Date (Certificate No.)	Scheduled Calibration
Power meter EPM-442A	GB37480704	07-Oct-14 (No. 217-02020)	Oct-15
Power sensor HP 8481A	US37292783	07-Oct-14 (No. 217-02020)	Oct-15
Power sensor HP 8481A	MY41092317	07-Oct-14 (No. 217-02021)	Oct-15
Reference 20 dB Attenuator	SN: 5058 (20k)	03-Apr-14 (No. 217-01918)	Apr-15
Type-N mismatch combination	SN: 5047.2 / 06327	03-Apr-14 (No. 217-01921)	Apr-15
Reference Probe ES3DV3	SN: 3205	30-Dec-14 (No. ES3-3205_Dec14)	Dec-15
DAE4	SN: 601	18-Aug-14 (No. DAE4-601_Aug14)	Aug-15
Secondary Standards	ID #	Check Date (in house)	Scheduled Check
RF generator R&S SMT-06	100005	04-Aug-99 (in house check Oct-13)	In house check: Oct-16
Network Analyzer HP 8753E	US37390585 S4206	18-Oct-01 (in house check Oct-14)	In house check: Oct-15

Calibrated by: **Michael Weber** Name: Michael Weber Function: Laboratory Technician

Signature

Approved by: **Katja Pokovic** Name: Katja Pokovic Function: Technical Manager

Issued: February 18, 2015

This calibration certificate shall not be reproduced except in full without written approval of the laboratory.



Accredited by the Swiss Accreditation Service (SAS)
The Swiss Accreditation Service is one of the signatories to the EA
Multilateral Agreement for the recognition of calibration certificates

Accreditation No.: **SCS 0108**

Glossary:

TSL	tissue simulating liquid
ConvF	sensitivity in TSL / NORM x,y,z
N/A	not applicable or not measured

Calibration is Performed According to the Following Standards:

- IEEE Std 1528-2013, "IEEE Recommended Practice for Determining the Peak Spatial-Averaged Specific Absorption Rate (SAR) in the Human Head from Wireless Communications Devices: Measurement Techniques", June 2013
- IEC 62209-1, "Procedure to measure the Specific Absorption Rate (SAR) for hand-held devices used in close proximity to the ear (frequency range of 300 MHz to 3 GHz)", February 2005
- KDB 865664, "SAR Measurement Requirements for 100 MHz to 6 GHz"

Additional Documentation:

- DASY4/5 System Handbook

Methods Applied and Interpretation of Parameters:

- Measurement Conditions:* Further details are available from the Validation Report at the end of the certificate. All figures stated in the certificate are valid at the frequency indicated.
- Antenna Parameters with TSL:* The dipole is mounted with the spacer to position its feed point exactly below the center marking of the flat phantom section, with the arms oriented parallel to the body axis.
- Feed Point Impedance and Return Loss:* These parameters are measured with the dipole positioned under the liquid filled phantom. The impedance stated is transformed from the measurement at the SMA connector to the feed point. The Return Loss ensures low reflected power. No uncertainty required.
- Electrical Delay:* One-way delay between the SMA connector and the antenna feed point. No uncertainty required.
- SAR measured:* SAR measured at the stated antenna input power.
- SAR normalized:* SAR as measured, normalized to an input power of 1 W at the antenna connector.
- SAR for nominal TSL parameters:* The measured TSL parameters are used to calculate the nominal SAR result.

The reported uncertainty of measurement is stated as the standard uncertainty of measurement multiplied by the coverage factor $k=2$, which for a normal distribution corresponds to a coverage probability of approximately 95%.

Measurement Conditions

DASY system configuration, as far as not given on page 1.

DASY Version	DASY5	V52.8.8
Extrapolation	Advanced Extrapolation	
Phantom	Modular Flat Phantom	
Distance Dipole Center - TSL	10 mm	with Spacer
Zoom Scan Resolution	dx, dy, dz = 5 mm	
Frequency	1900 MHz \pm 1 MHz	

Head TSL parameters

The following parameters and calculations were applied.

	Temperature	Permittivity	Conductivity
Nominal Head TSL parameters	22.0 °C	40.0	1.40 mho/m
Measured Head TSL parameters	(22.0 \pm 0.2) °C	39.1 \pm 6 %	1.42 mho/m \pm 6 %
Head TSL temperature change during test	< 0.5 °C	----	----

SAR result with Head TSL

SAR averaged over 1 cm³ (1 g) of Head TSL	Condition	
SAR measured	250 mW input power	10.3 W/kg
SAR for nominal Head TSL parameters	normalized to 1W	40.6 W/kg \pm 17.0 % (k=2)

SAR averaged over 10 cm³ (10 g) of Head TSL	condition	
SAR measured	250 mW input power	5.37 W/kg
SAR for nominal Head TSL parameters	normalized to 1W	21.3 W/kg \pm 16.5 % (k=2)

Body TSL parameters

The following parameters and calculations were applied.

	Temperature	Permittivity	Conductivity
Nominal Body TSL parameters	22.0 °C	53.3	1.52 mho/m
Measured Body TSL parameters	(22.0 \pm 0.2) °C	53.1 \pm 6 %	1.53 mho/m \pm 6 %
Body TSL temperature change during test	< 0.5 °C	----	----

SAR result with Body TSL

SAR averaged over 1 cm³ (1 g) of Body TSL	Condition	
SAR measured	250 mW input power	10.1 W/kg
SAR for nominal Body TSL parameters	normalized to 1W	40.2 W/kg \pm 17.0 % (k=2)

SAR averaged over 10 cm³ (10 g) of Body TSL	condition	
SAR measured	250 mW input power	5.40 W/kg
SAR for nominal Body TSL parameters	normalized to 1W	21.5 W/kg \pm 16.5 % (k=2)

Appendix (Additional assessments outside the scope of SCS0108)

Antenna Parameters with Head TSL

Impedance, transformed to feed point	52.4 Ω + 6.2 j Ω
Return Loss	- 23.8 dB

Antenna Parameters with Body TSL

Impedance, transformed to feed point	48.2 Ω + 6.6 j Ω
Return Loss	- 23.1 dB

General Antenna Parameters and Design

Electrical Delay (one direction)	1.198 ns
----------------------------------	----------

After long term use with 100W radiated power, only a slight warming of the dipole near the feedpoint can be measured.

The dipole is made of standard semirigid coaxial cable. The center conductor of the feeding line is directly connected to the second arm of the dipole. The antenna is therefore short-circuited for DC-signals. On some of the dipoles, small end caps are added to the dipole arms in order to improve matching when loaded according to the position as explained in the "Measurement Conditions" paragraph. The SAR data are not affected by this change. The overall dipole length is still according to the Standard.

No excessive force must be applied to the dipole arms, because they might bend or the soldered connections near the feedpoint may be damaged.

Additional EUT Data

Manufactured by	SPEAG
Manufactured on	March 11, 2011

DASY5 Validation Report for Head TSL

Date: 18.02.2015

Test Laboratory: SPEAG, Zurich, Switzerland

DUT: Dipole 1900 MHz; Type: D1900V2; Serial: D1900V2 - SN: 5d148

Communication System: UID 0 - CW; Frequency: 1900 MHz

Medium parameters used: $f = 1900$ MHz; $\sigma = 1.42$ S/m; $\epsilon_r = 39.1$; $\rho = 1000$ kg/m³

Phantom section: Flat Section

Measurement Standard: DASY5 (IEEE/IEC/ANSI C63.19-2011)

DASY52 Configuration:

- Probe: ES3DV3 - SN3205; ConvF(5, 5, 5); Calibrated: 30.12.2014;
- Sensor-Surface: 3mm (Mechanical Surface Detection)
- Electronics: DAE4 Sn601; Calibrated: 18.08.2014
- Phantom: Flat Phantom 5.0 (front); Type: QD000P50AA; Serial: 1001
- DASY52 52.8.8(1222); SEMCAD X 14.6.10(7331)

Dipole Calibration for Head Tissue/Pin=250 mW, d=10mm/Zoom Scan (7x7x7)/Cube 0:

Measurement grid: dx=5mm, dy=5mm, dz=5mm

Reference Value = 98.30 V/m; Power Drift = 0.02 dB

Peak SAR (extrapolated) = 18.8 W/kg

SAR(1 g) = 10.3 W/kg; SAR(10 g) = 5.37 W/kg

Maximum value of SAR (measured) = 13.0 W/kg

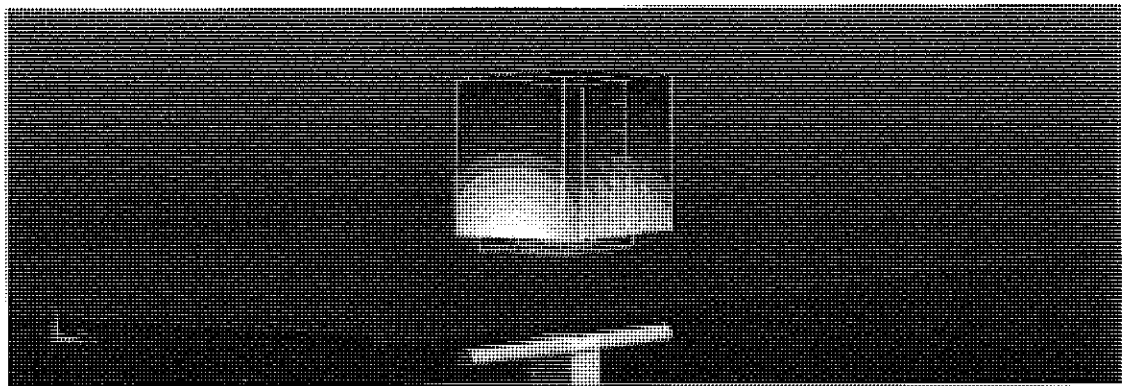
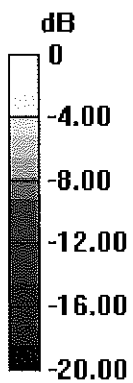

0 dB = 13.0 W/kg = 11.14 dBW/kg

Impedance Measurement Plot for Head TSL

18 Feb 2015 13:12:24

CH1 S11 1 U FS 1: 52.393 Ω 6.1895 Ω 518.46 μH 1 900.000 000 MHz

*
De1
CA
Avg
16
H1d

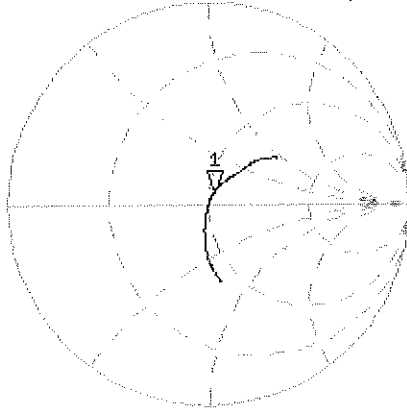

CH2 S11 LOG 5 dB/REF -20 dB 1: -23.774 dB 1 900.000 000 MHz

CA
Avg
16
H1d

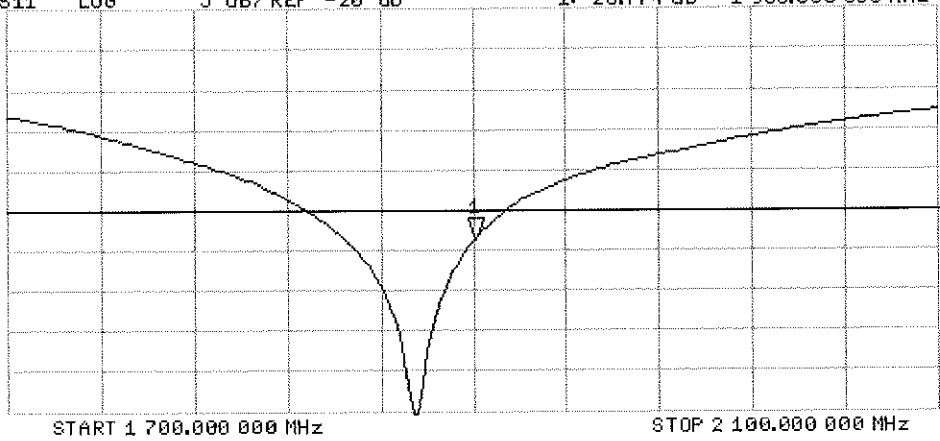

Impedance Measurement Plot for Body TSL

18 Feb 2015 13:11:53

CH1 S11 1 U FS 1: 48.238 Ω 6.6348 Ω 555.77 pF 1 900.000 000 MHz

*
De l
CA
Avg
16
H1 d

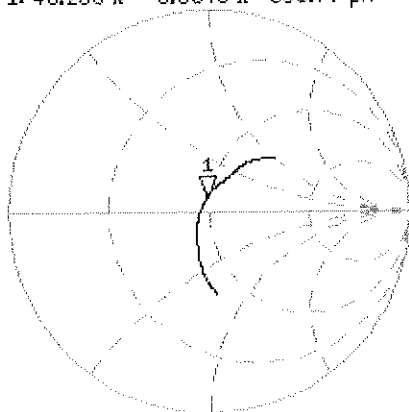

CH2 S11 LOG 5 dB/REF -20 dB 1: -23.131 dB 1 900.000 000 MHz

CA
Avg
16
H1 d

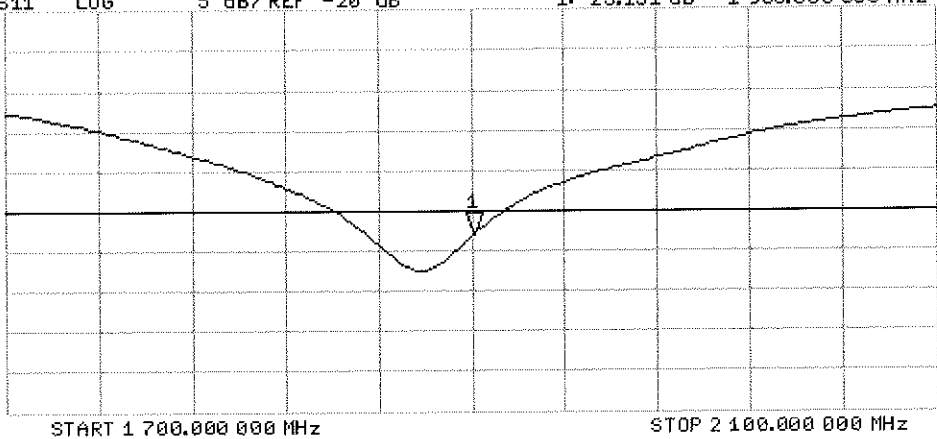

DASY5 Validation Report for Body TSL

Date: 18.02.2015

Test Laboratory: SPEAG, Zurich, Switzerland

DUT: Dipole 1900 MHz; Type: D1900V2; Serial: D1900V2 - SN: 5d148

Communication System: UID 0 - CW; Frequency: 1900 MHz

Medium parameters used: $f = 1900$ MHz; $\sigma = 1.53$ S/m; $\epsilon_r = 53.1$; $\rho = 1000$ kg/m³

Phantom section: Flat Section

Measurement Standard: DASY5 (IEEE/IEC/ANSI C63.19-2011)

DASY52 Configuration:

- Probe: ES3DV3 - SN3205; ConvF(4.65, 4.65, 4.65); Calibrated: 30.12.2014;
- Sensor-Surface: 3mm (Mechanical Surface Detection)
- Electronics: DAE4 Sn601; Calibrated: 18.08.2014
- Phantom: Flat Phantom 5.0 (back); Type: QD000P50AA; Serial: 1002
- DASY52 52.8.8(1222); SEMCAD X 14.6.10(7331)

Dipole Calibration for Body Tissue/Pin=250 mW, d=10mm/Zoom Scan (7x7x7)/Cube 0:

Measurement grid: dx=5mm, dy=5mm, dz=5mm

Reference Value = 95.79 V/m; Power Drift = -0.01 dB

Peak SAR (extrapolated) = 17.2 W/kg

SAR(1 g) = 10.1 W/kg; SAR(10 g) = 5.4 W/kg

Maximum value of SAR (measured) = 12.7 W/kg

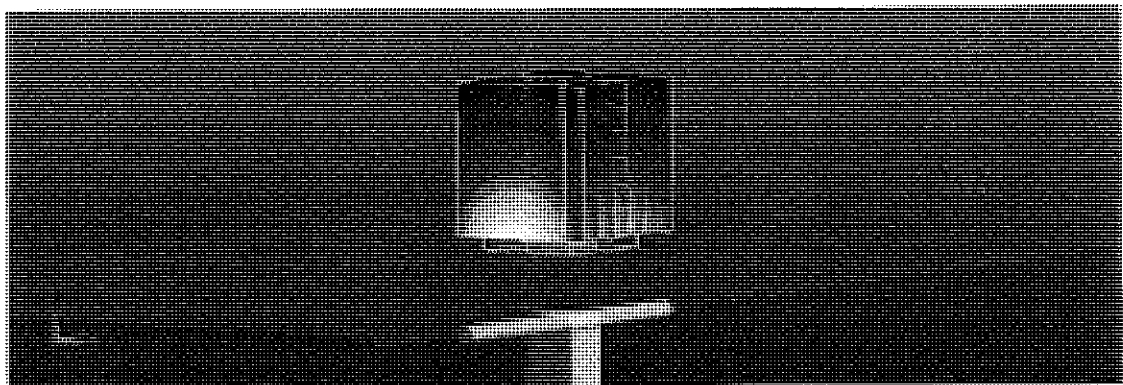
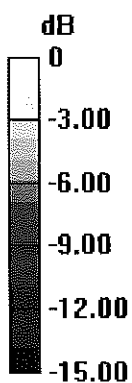

0 dB = 12.7 W/kg = 11.04 dBW/kg



Accredited by the Swiss Accreditation Service (SAS)
The Swiss Accreditation Service is one of the signatories to the EA
Multilateral Agreement for the recognition of calibration certificates

Accreditation No.: **SCS 0108**

Client **PC Test**

Certificate No: **D2450V2-882_Feb15**

CALIBRATION CERTIFICATE

Object **D2450V2 - SN:882**

Calibration procedure(s) **QA CAL-05.v9
Calibration procedure for dipole validation kits above 700 MHz**

Calibration date: **February 18, 2015**

PTV
3/6/15

This calibration certificate documents the traceability to national standards, which realize the physical units of measurements (SI).
The measurements and the uncertainties with confidence probability are given on the following pages and are part of the certificate.

All calibrations have been conducted in the closed laboratory facility: environment temperature (22 ± 3)°C and humidity < 70%.

Calibration Equipment used (M&TE critical for calibration)

Primary Standards	ID #	Cal Date (Certificate No.)	Scheduled Calibration
Power meter EPM-442A	GB37480704	07-Oct-14 (No. 217-02020)	Oct-15
Power sensor HP 8481A	US37292783	07-Oct-14 (No. 217-02020)	Oct-15
Power sensor HP 8481A	MY41092317	07-Oct-14 (No. 217-02021)	Oct-15
Reference 20 dB Attenuator	SN: 5058 (20k)	03-Apr-14 (No. 217-01918)	Apr-15
Type-N mismatch combination	SN: 5047.2 / 06327	03-Apr-14 (No. 217-01921)	Apr-15
Reference Probe ES3DV3	SN: 3205	30-Dec-14 (No. ES3-3205_Dec14)	Dec-15
DAE4	SN: 601	18-Aug-14 (No. DAE4-601_Aug14)	Aug-15
Secondary Standards	ID #	Check Date (in house)	Scheduled Check
RF generator R&S SMT-06	100005	04-Aug-99 (in house check Oct-13)	In house check: Oct-16
Network Analyzer HP 8753E	US37390585 S4206	18-Oct-01 (in house check Oct-14)	In house check: Oct-15

Calibrated by: **Michael Weber** Name: Michael Weber Function: Laboratory Technician

Signature: *[Handwritten Signature]*

Approved by: **Katja Pokovic** Name: Katja Pokovic Function: Technical Manager

Signature: *[Handwritten Signature]*

Issued: February 18, 2015

This calibration certificate shall not be reproduced except in full without written approval of the laboratory.



Accreditation No.: **SCS 0108**

Accredited by the Swiss Accreditation Service (SAS)
The Swiss Accreditation Service is one of the signatories to the EA
Multilateral Agreement for the recognition of calibration certificates

Glossary:

TSL	tissue simulating liquid
ConvF	sensitivity in TSL / NORM x,y,z
N/A	not applicable or not measured

Calibration is Performed According to the Following Standards:

- a) IEEE Std 1528-2013, "IEEE Recommended Practice for Determining the Peak Spatial-Averaged Specific Absorption Rate (SAR) in the Human Head from Wireless Communications Devices: Measurement Techniques", June 2013
- b) IEC 62209-1, "Procedure to measure the Specific Absorption Rate (SAR) for hand-held devices used in close proximity to the ear (frequency range of 300 MHz to 3 GHz)", February 2005
- c) KDB 865664, "SAR Measurement Requirements for 100 MHz to 6 GHz"

Additional Documentation:

- d) DASY4/5 System Handbook

Methods Applied and Interpretation of Parameters:

- *Measurement Conditions:* Further details are available from the Validation Report at the end of the certificate. All figures stated in the certificate are valid at the frequency indicated.
- *Antenna Parameters with TSL:* The dipole is mounted with the spacer to position its feed point exactly below the center marking of the flat phantom section, with the arms oriented parallel to the body axis.
- *Feed Point Impedance and Return Loss:* These parameters are measured with the dipole positioned under the liquid filled phantom. The impedance stated is transformed from the measurement at the SMA connector to the feed point. The Return Loss ensures low reflected power. No uncertainty required.
- *Electrical Delay:* One-way delay between the SMA connector and the antenna feed point. No uncertainty required.
- *SAR measured:* SAR measured at the stated antenna input power.
- *SAR normalized:* SAR as measured, normalized to an input power of 1 W at the antenna connector.
- *SAR for nominal TSL parameters:* The measured TSL parameters are used to calculate the nominal SAR result.

The reported uncertainty of measurement is stated as the standard uncertainty of measurement multiplied by the coverage factor $k=2$, which for a normal distribution corresponds to a coverage probability of approximately 95%.

Measurement Conditions

DASY system configuration, as far as not given on page 1.

DASY Version	DASY5	V52.8.8
Extrapolation	Advanced Extrapolation	
Phantom	Modular Flat Phantom	
Distance Dipole Center - TSL	10 mm	with Spacer
Zoom Scan Resolution	dx, dy, dz = 5 mm	
Frequency	2450 MHz \pm 1 MHz	

Head TSL parameters

The following parameters and calculations were applied.

	Temperature	Permittivity	Conductivity
Nominal Head TSL parameters	22.0 °C	39.2	1.80 mho/m
Measured Head TSL parameters	(22.0 \pm 0.2) °C	38.2 \pm 6 %	1.87 mho/m \pm 6 %
Head TSL temperature change during test	< 0.5 °C	----	----

SAR result with Head TSL

SAR averaged over 1 cm³ (1 g) of Head TSL	Condition	
SAR measured	250 mW input power	13.4 W/kg
SAR for nominal Head TSL parameters	normalized to 1W	52.3 W/kg \pm 17.0 % (k=2)

SAR averaged over 10 cm³ (10 g) of Head TSL	condition	
SAR measured	250 mW input power	6.16 W/kg
SAR for nominal Head TSL parameters	normalized to 1W	24.3 W/kg \pm 16.5 % (k=2)

Body TSL parameters

The following parameters and calculations were applied.

	Temperature	Permittivity	Conductivity
Nominal Body TSL parameters	22.0 °C	52.7	1.95 mho/m
Measured Body TSL parameters	(22.0 \pm 0.2) °C	51.7 \pm 6 %	2.04 mho/m \pm 6 %
Body TSL temperature change during test	< 0.5 °C	----	----

SAR result with Body TSL

SAR averaged over 1 cm³ (1 g) of Body TSL	Condition	
SAR measured	250 mW input power	13.0 W/kg
SAR for nominal Body TSL parameters	normalized to 1W	50.7 W/kg \pm 17.0 % (k=2)

SAR averaged over 10 cm³ (10 g) of Body TSL	condition	
SAR measured	250 mW input power	5.97 W/kg
SAR for nominal Body TSL parameters	normalized to 1W	23.5 W/kg \pm 16.5 % (k=2)

Appendix (Additional assessments outside the scope of SCS0108)

Antenna Parameters with Head TSL

Impedance, transformed to feed point	52.8 Ω - 0.2 j Ω
Return Loss	- 31.2 dB

Antenna Parameters with Body TSL

Impedance, transformed to feed point	50.4 Ω + 1.9 j Ω
Return Loss	- 34.4 dB

General Antenna Parameters and Design

Electrical Delay (one direction)	1.156 ns
----------------------------------	----------

After long term use with 100W radiated power, only a slight warming of the dipole near the feedpoint can be measured.

The dipole is made of standard semirigid coaxial cable. The center conductor of the feeding line is directly connected to the second arm of the dipole. The antenna is therefore short-circuited for DC-signals. On some of the dipoles, small end caps are added to the dipole arms in order to improve matching when loaded according to the position as explained in the "Measurement Conditions" paragraph. The SAR data are not affected by this change. The overall dipole length is still according to the Standard.

No excessive force must be applied to the dipole arms, because they might bend or the soldered connections near the feedpoint may be damaged.

Additional EUT Data

Manufactured by	SPEAG
Manufactured on	October 06, 2011

DASY5 Validation Report for Head TSL

Date: 18.02.2015

Test Laboratory: SPEAG, Zurich, Switzerland

DUT: Dipole 2450 MHz; Type: D2450V2; Serial: D2450V2 - SN:882

Communication System: UID 0 - CW; Frequency: 2450 MHz

Medium parameters used: $f = 2450$ MHz; $\sigma = 1.87$ S/m; $\epsilon_r = 38.2$; $\rho = 1000$ kg/m³

Phantom section: Flat Section

Measurement Standard: DASY5 (IEEE/IEC/ANSI C63.19-2011)

DASY52 Configuration:

- Probe: ES3DV3 - SN3205; ConvF(4.54, 4.54, 4.54); Calibrated: 30.12.2014;
- Sensor-Surface: 3mm (Mechanical Surface Detection)
- Electronics: DAE4 Sn601; Calibrated: 18.08.2014
- Phantom: Flat Phantom 5.0 (front); Type: QD000P50AA; Serial: 1001
- DASY52 52.8.8(1222); SEMCAD X 14.6.10(7331)

Dipole Calibration for Head Tissue - ES Probe/Pin=250 mW, d=10mm/Zoom Scan

(7x7x7)/Cube 0: Measurement grid: dx=5mm, dy=5mm, dz=5mm

Reference Value = 99.95 V/m; Power Drift = 0.03 dB

Peak SAR (extrapolated) = 27.9 W/kg

SAR(1 g) = 13.4 W/kg; SAR(10 g) = 6.16 W/kg

Maximum value of SAR (measured) = 17.3 W/kg

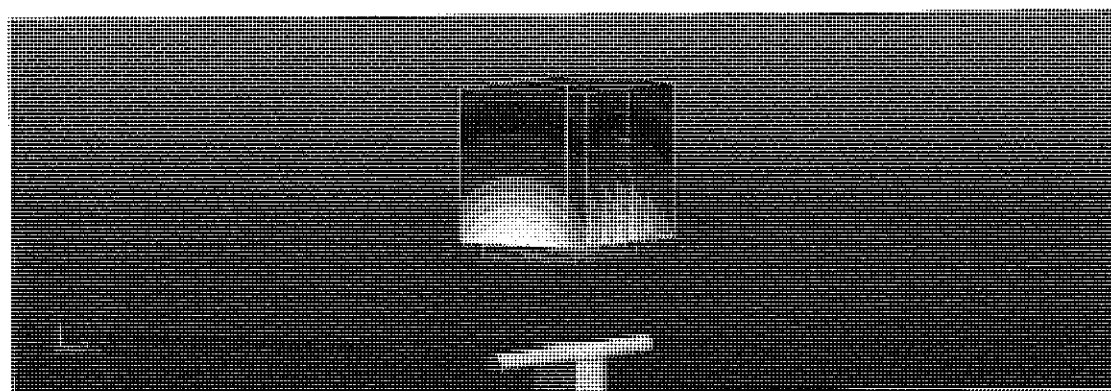
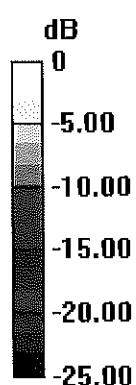

0 dB = 17.3 W/kg = 12.38 dBW/kg

Impedance Measurement Plot for Head TSL

18 Feb 2015 11:27:18

CH1 S11 1 U FS 1: 52.885 Δ -212.89 m Δ 305.14 pF 2 450.000 000 MHz

*
De1
C Δ

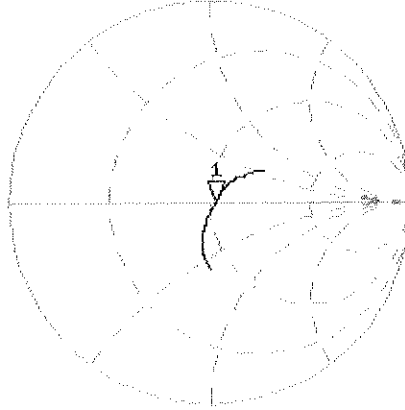

Avg
16

H1d

CH2 S11 LOG 5 dB/REF -20 dB 1: -31.245 dB 2 450.000 000 MHz

C Δ

Avg
16

H1d

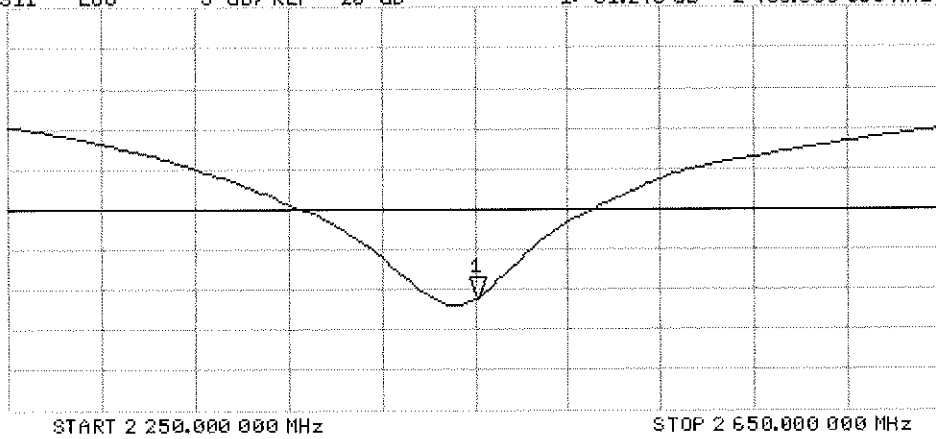

DASY5 Validation Report for Body TSL

Date: 18.02.2015

Test Laboratory: SPEAG, Zurich, Switzerland

DUT: Dipole 2450 MHz; Type: D2450V2; Serial: D2450V2 - SN:882

Communication System: UID 0 - CW; Frequency: 2450 MHz

Medium parameters used: $f = 2450$ MHz; $\sigma = 2.04$ S/m; $\epsilon_r = 51.7$; $\rho = 1000$ kg/m³

Phantom section: Flat Section

Measurement Standard: DASY5 (IEEE/IEC/ANSI C63.19-2011)

DASY52 Configuration:

- Probe: ES3DV3 - SN3205; ConvF(4.32, 4.32, 4.32); Calibrated: 30.12.2014;
- Sensor-Surface: 3mm (Mechanical Surface Detection)
- Electronics: DAE4 Sn601; Calibrated: 18.08.2014
- Phantom: Flat Phantom 5.0 (back); Type: QD000P50AA; Serial: 1002
- DASY52 52.8.8(1222); SEMCAD X 14.6.10(7331)

Dipole Calibration for Body Tissue - ES Probe/Pin=250 mW, d=10mm/Zoom Scan

(7x7x7)/Cube 0: Measurement grid: dx=5mm, dy=5mm, dz=5mm

Reference Value = 94.16 V/m; Power Drift = 0.02 dB

Peak SAR (extrapolated) = 27.2 W/kg

SAR(1 g) = 13 W/kg; SAR(10 g) = 5.97 W/kg

Maximum value of SAR (measured) = 17.0 W/kg

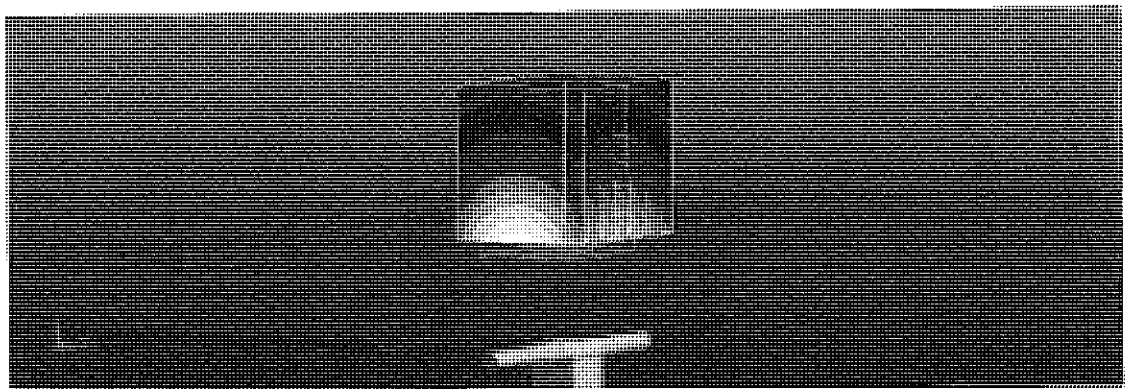
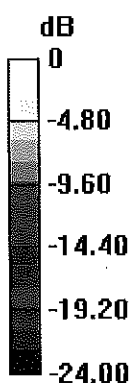

0 dB = 17.0 W/kg = 12.30 dBW/kg

Impedance Measurement Plot for Body TSL

18 Feb 2015 11:26:48

CH1 S11 1 U FS 1: 50.354 Δ 1.8009 Δ 122.10 pF 2 450.000 000 MHz

*
De1
C Δ
Avg
15

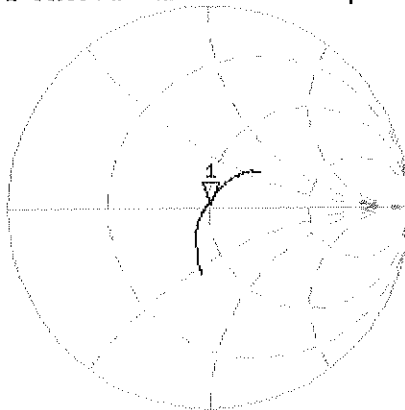

H1d

CH2 S11 LOG 5 dB/REF -20 dB 1: -34.367 dB 2 450.000 000 MHz

C Δ
Avg
15
H1d

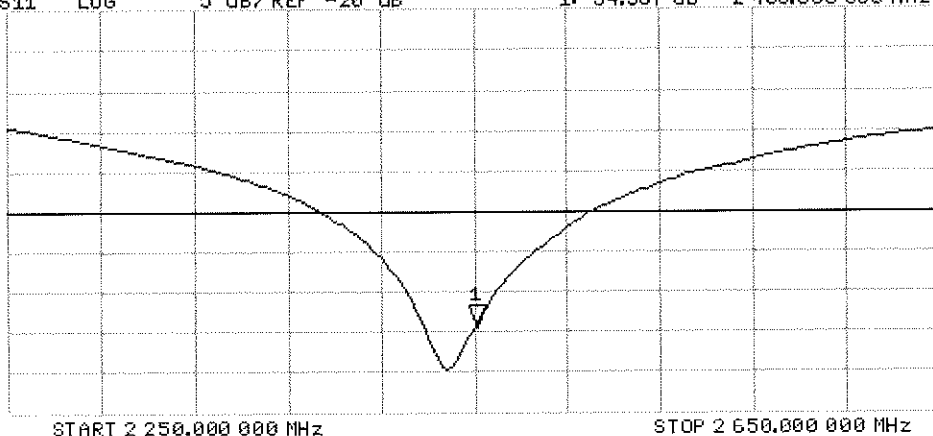



Accredited by the Swiss Accreditation Service (SAS)
The Swiss Accreditation Service is one of the signatories to the EA
Multilateral Agreement for the recognition of calibration certificates

Accreditation No.: **SCS 0108**

Client **PC Test**

Certificate No: **D2600V2-1004_Apr15**

CALIBRATION CERTIFICATE

Object **D2600V2 - SN: 1004**

Calibration procedure(s) **QA CAL-05.v9
Calibration procedure for dipole validation kits above 700 MHz**

Calibration date: **April 14, 2015**

*PN ✓
4/29/15*

This calibration certificate documents the traceability to national standards, which realize the physical units of measurements (SI).
The measurements and the uncertainties with confidence probability are given on the following pages and are part of the certificate.

All calibrations have been conducted in the closed laboratory facility: environment temperature (22 ± 3)°C and humidity < 70%.

Calibration Equipment used (M&TE critical for calibration)

Primary Standards	ID #	Cal Date (Certificate No.)	Scheduled Calibration
Power meter EPM-442A	GB37480704	07-Oct-14 (No. 217-02020)	Oct-15
Power sensor HP 8481A	US37292783	07-Oct-14 (No. 217-02020)	Oct-15
Power sensor HP 8481A	MY41092317	07-Oct-14 (No. 217-02021)	Oct-15
Reference 20 dB Attenuator	SN: 5058 (20k)	01-Apr-15 (No. 217-02131)	Mar-16
Type-N mismatch combination	SN: 5047.2 / 06327	01-Apr-15 (No. 217-02134)	Mar-16
Reference Probe ES3DV3	SN: 3205	30-Dec-14 (No. ES3-3205_Dec14)	Dec-15
DAE4	SN: 601	18-Aug-14 (No. DAE4-601_Aug14)	Aug-15
Secondary Standards	ID #	Check Date (in house)	Scheduled Check
RF generator R&S SMT-06	100005	04-Aug-99 (in house check Oct-13)	In house check: Oct-16
Network Analyzer HP 8753E	US37390585 S4206	18-Oct-01 (in house check Oct-14)	In house check: Oct-15

Calibrated by: **Claudio Leubler** Function: **Laboratory Technician** Signature: *[Signature]*

Approved by: **Katja Pokovic** Technical Manager *[Signature]*

Issued: April 14, 2015

This calibration certificate shall not be reproduced except in full without written approval of the laboratory.



Accredited by the Swiss Accreditation Service (SAS)

The Swiss Accreditation Service is one of the signatories to the EA
Multilateral Agreement for the recognition of calibration certificates

Accreditation No.: **SCS 0108**

Glossary:

TSL	tissue simulating liquid
ConvF	sensitivity in TSL / NORM x,y,z
N/A	not applicable or not measured

Calibration is Performed According to the Following Standards:

- IEEE Std 1528-2013, "IEEE Recommended Practice for Determining the Peak Spatial-Averaged Specific Absorption Rate (SAR) in the Human Head from Wireless Communications Devices: Measurement Techniques", June 2013
- IEC 62209-1, "Procedure to measure the Specific Absorption Rate (SAR) for hand-held devices used in close proximity to the ear (frequency range of 300 MHz to 3 GHz)", February 2005
- KDB 865664, "SAR Measurement Requirements for 100 MHz to 6 GHz"

Additional Documentation:

- DASY4/5 System Handbook

Methods Applied and Interpretation of Parameters:

- Measurement Conditions:** Further details are available from the Validation Report at the end of the certificate. All figures stated in the certificate are valid at the frequency indicated.
- Antenna Parameters with TSL:** The dipole is mounted with the spacer to position its feed point exactly below the center marking of the flat phantom section, with the arms oriented parallel to the body axis.
- Feed Point Impedance and Return Loss:** These parameters are measured with the dipole positioned under the liquid filled phantom. The impedance stated is transformed from the measurement at the SMA connector to the feed point. The Return Loss ensures low reflected power. No uncertainty required.
- Electrical Delay:** One-way delay between the SMA connector and the antenna feed point. No uncertainty required.
- SAR measured:** SAR measured at the stated antenna input power.
- SAR normalized:** SAR as measured, normalized to an input power of 1 W at the antenna connector.
- SAR for nominal TSL parameters:** The measured TSL parameters are used to calculate the nominal SAR result.

The reported uncertainty of measurement is stated as the standard uncertainty of measurement multiplied by the coverage factor $k=2$, which for a normal distribution corresponds to a coverage probability of approximately 95%.

Measurement Conditions

DASY system configuration, as far as not given on page 1.

DASY Version	DASY5	V52.8.8
Extrapolation	Advanced Extrapolation	
Phantom	Modular Flat Phantom	
Distance Dipole Center - TSL	10 mm	with Spacer
Zoom Scan Resolution	dx, dy, dz = 5 mm	
Frequency	2600 MHz \pm 1 MHz	

Head TSL parameters

The following parameters and calculations were applied.

	Temperature	Permittivity	Conductivity
Nominal Head TSL parameters	22.0 °C	39.0	1.96 mho/m
Measured Head TSL parameters	(22.0 \pm 0.2) °C	37.1 \pm 6 %	1.99 mho/m \pm 6 %
Head TSL temperature change during test	< 0.5 °C	----	----

SAR result with Head TSL

SAR averaged over 1 cm³ (1 g) of Head TSL	Condition	
SAR measured	250 mW input power	14.2 W/kg
SAR for nominal Head TSL parameters	normalized to 1W	55.8 W/kg \pm 17.0 % (k=2)

SAR averaged over 10 cm³ (10 g) of Head TSL	condition	
SAR measured	250 mW input power	6.37 W/kg
SAR for nominal Head TSL parameters	normalized to 1W	25.2 W/kg \pm 16.5 % (k=2)

Body TSL parameters

The following parameters and calculations were applied.

	Temperature	Permittivity	Conductivity
Nominal Body TSL parameters	22.0 °C	52.5	2.16 mho/m
Measured Body TSL parameters	(22.0 \pm 0.2) °C	50.2 \pm 6 %	2.20 mho/m \pm 6 %
Body TSL temperature change during test	< 0.5 °C	----	----

SAR result with Body TSL

SAR averaged over 1 cm³ (1 g) of Body TSL	Condition	
SAR measured	250 mW input power	14.3 W/kg
SAR for nominal Body TSL parameters	normalized to 1W	56.2 W/kg \pm 17.0 % (k=2)

SAR averaged over 10 cm³ (10 g) of Body TSL	condition	
SAR measured	250 mW input power	6.39 W/kg
SAR for nominal Body TSL parameters	normalized to 1W	25.3 W/kg \pm 16.5 % (k=2)

Appendix (Additional assessments outside the scope of SCS 0108)

Antenna Parameters with Head TSL

Impedance, transformed to feed point	49.6 Ω - 4.7 j Ω
Return Loss	- 26.5 dB

Antenna Parameters with Body TSL

Impedance, transformed to feed point	46.5 Ω - 3.6 j Ω
Return Loss	- 25.6 dB

General Antenna Parameters and Design

Electrical Delay (one direction)	1.150 ns
----------------------------------	----------

After long term use with 100W radiated power, only a slight warming of the dipole near the feedpoint can be measured.

The dipole is made of standard semirigid coaxial cable. The center conductor of the feeding line is directly connected to the second arm of the dipole. The antenna is therefore short-circuited for DC-signals. On some of the dipoles, small end caps are added to the dipole arms in order to improve matching when loaded according to the position as explained in the "Measurement Conditions" paragraph. The SAR data are not affected by this change. The overall dipole length is still according to the Standard.

No excessive force must be applied to the dipole arms, because they might bend or the soldered connections near the feedpoint may be damaged.

Additional EUT Data

Manufactured by	SPEAG
Manufactured on	December 23, 2006

DASY5 Validation Report for Head TSL

Date: 14.04.2015

Test Laboratory: SPEAG, Zurich, Switzerland

DUT: Dipole 2600 MHz; Type: D2600V2; Serial: D2600V2 - SN: 1004

Communication System: UID 0 - CW; Frequency: 2600 MHz

Medium parameters used: $f = 2600$ MHz; $\sigma = 1.99$ S/m; $\epsilon_r = 37.1$; $\rho = 1000$ kg/m³

Phantom section: Flat Section

Measurement Standard: DASY5 (IEEE/IEC/ANSI C63.19-2011)

DASY52 Configuration:

- Probe: ES3DV3 - SN3205; ConvF(4.49, 4.49, 4.49); Calibrated: 30.12.2014;
- Sensor-Surface: 3mm (Mechanical Surface Detection)
- Electronics: DAE4 Sn601; Calibrated: 18.08.2014
- Phantom: Flat Phantom 5.0 (front); Type: QD000P50AA; Serial: 1001
- DASY52 52.8.8(1222); SEMCAD X 14.6.10(7331)

Dipole Calibration for Head/Pin=250 mW, d=10mm/Zoom Scan (7x7x7)/Cube 0:

Measurement grid: dx=5mm, dy=5mm, dz=5mm

Reference Value = 99.70 V/m; Power Drift = 0.06 dB

Peak SAR (extrapolated) = 29.8 W/kg

SAR(1 g) = 14.2 W/kg; SAR(10 g) = 6.37 W/kg

Maximum value of SAR (measured) = 17.9 W/kg

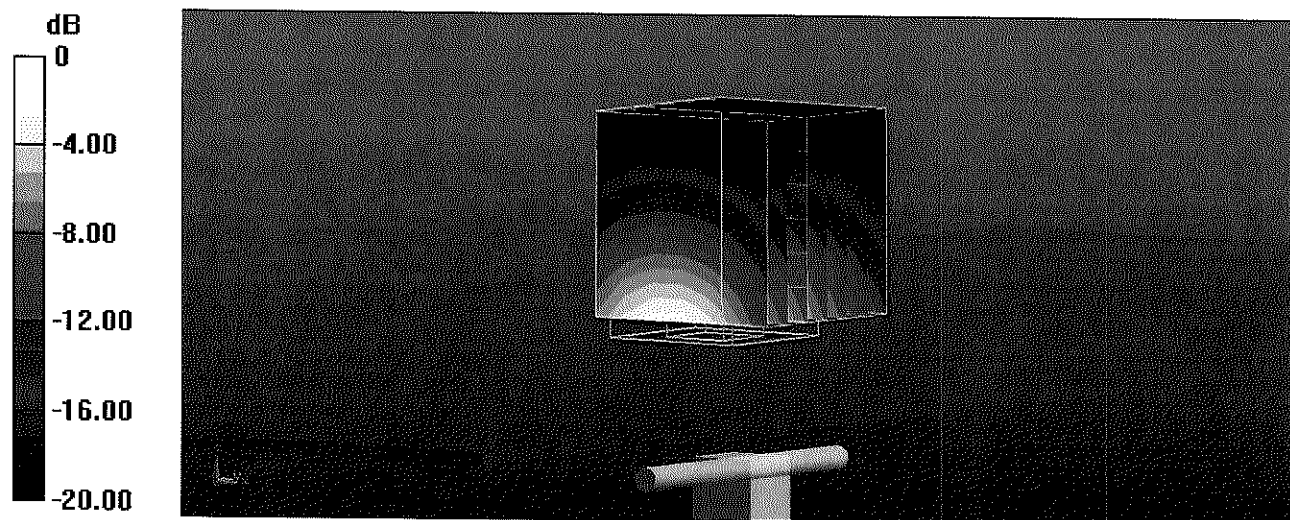

0 dB = 17.9 W/kg = 12.53 dBW/kg

Impedance Measurement Plot for Head TSL

14 Apr 2015 14:35:37
[CH1] S11 1 U FS 1: 49.578 Ω -4.7090 Ω 12.999 pF 2 500.000 000 MHz

*
De1
CA
Avg
16
H1d

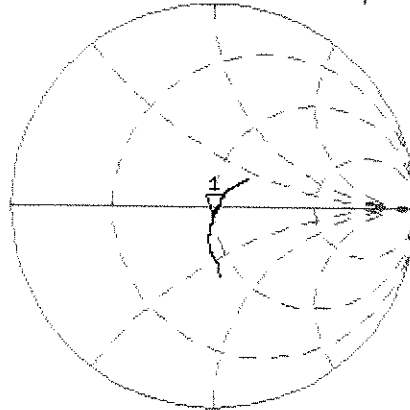

CH2 S11 LOG 5 dB/REF -20 dB 1:-26.482 dB 2 500.000 000 MHz

CA
Avg
16
H1d

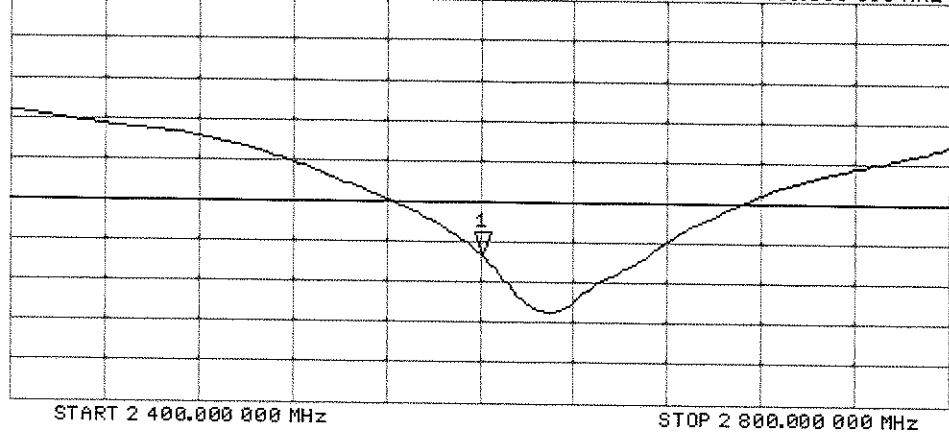

DASY5 Validation Report for Body TSL

Date: 14.04.2015

Test Laboratory: SPEAG, Zurich, Switzerland

DUT: Dipole 2600 MHz; Type: D2600V2; Serial: D2600V2 - SN: 1004

Communication System: UID 0 - CW; Frequency: 2600 MHz

Medium parameters used: $f = 2600$ MHz; $\sigma = 2.2$ S/m; $\epsilon_r = 50.2$; $\rho = 1000$ kg/m³

Phantom section: Flat Section

Measurement Standard: DASY5 (IEEE/IEC/ANSI C63.19-2011)

DASY52 Configuration:

- Probe: ES3DV3 - SN3205; ConvF(4.13, 4.13, 4.13); Calibrated: 30.12.2014;
- Sensor-Surface: 3mm (Mechanical Surface Detection)
- Electronics: DAE4 Sn601; Calibrated: 18.08.2014
- Phantom: Flat Phantom 5.0 (back); Type: QD000P50AA; Serial: 1002
- DASY52 52.8.8(1222); SEMCAD X 14.6.10(7331)

Dipole Calibration for Body/Pin=250 mW, d=10mm/Zoom Scan (7x7x7)/Cube 0:

Measurement grid: dx=5mm, dy=5mm, dz=5mm

Reference Value = 95.83 V/m; Power Drift = 0.06 dB

Peak SAR (extrapolated) = 29.6 W/kg

SAR(1 g) = 14.3 W/kg; SAR(10 g) = 6.39 W/kg

Maximum value of SAR (measured) = 18.3 W/kg

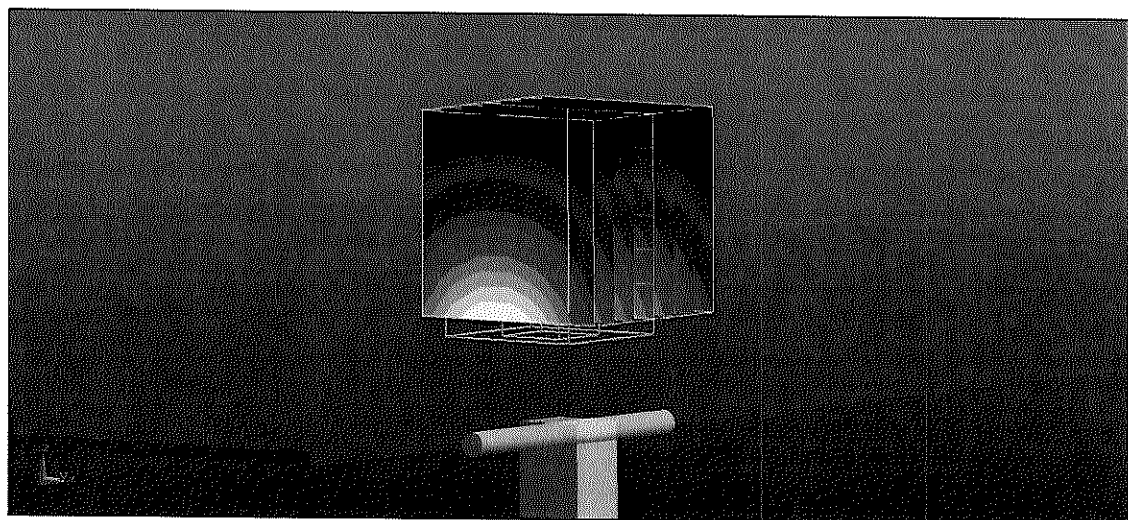
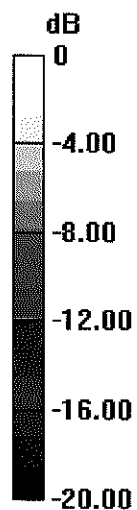

0 dB = 18.3 W/kg = 12.62 dBW/kg

Impedance Measurement Plot for Body TSL

14 Apr 2015 14:34:51
[CH1] S11 1 U FS 1: 46.463 Ω -3.6484 Ω 16.778 pF 2 600.000 000 MHz

*
Del
CA
Avg
16

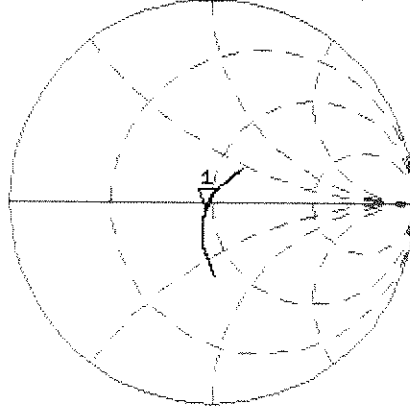

H1d

CH2 S11 LOG 5 dB/REF -20 dB 1:-25.570 dB 2 600.000 000 MHz

CA
Avg
16
H1d

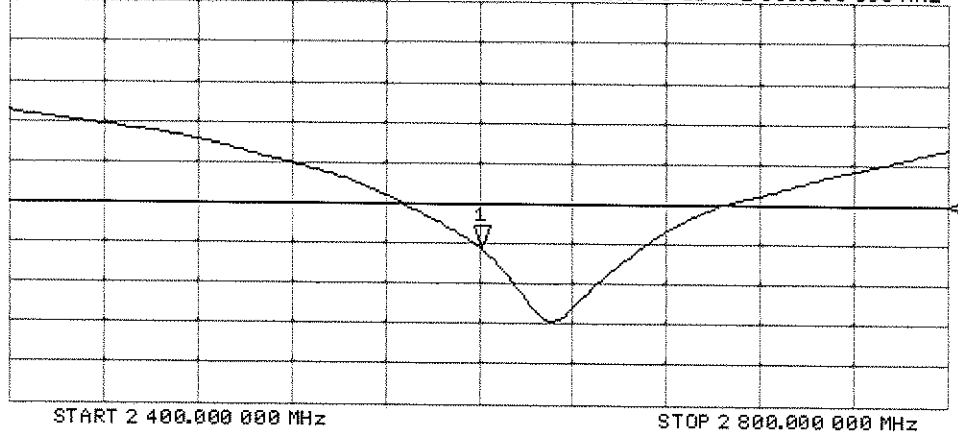



Accredited by the Swiss Accreditation Service (SAS)
The Swiss Accreditation Service is one of the signatories to the EA
Multilateral Agreement for the recognition of calibration certificates

Accreditation No.: **SCS 108**

Client **PC Test**

Certificate No: **D5GHzV2-1191_Sep14**

CALIBRATION CERTIFICATE

Object **D5GHzV2 - SN:1191**

Calibration procedure(s) **QA CAL-22.v2
Calibration procedure for dipole validation kits between 3-6 GHz**

*CC
11/14*

Calibration date: **September 25, 2014**

This calibration certificate documents the traceability to national standards, which realize the physical units of measurements (SI).
The measurements and the uncertainties with confidence probability are given on the following pages and are part of the certificate.

All calibrations have been conducted in the closed laboratory facility: environment temperature (22 ± 3)°C and humidity < 70%.

Calibration Equipment used (M&TE critical for calibration)

Primary Standards	ID #	Cal Date (Certificate No.)	Scheduled Calibration
Power meter EPM-442A	GB37480704	09-Oct-13 (No. 217-01827)	Oct-14
Power sensor HP 8481A	US37292783	09-Oct-13 (No. 217-01827)	Oct-14
Power sensor HP 8481A	MY41092317	09-Oct-13 (No. 217-01828)	Oct-14
Reference 20 dB Attenuator	SN: 5058 (20k)	03-Apr-14 (No. 217-01918)	Apr-15
Type-N mismatch combination	SN: 5047.2 / 06327	03-Apr-14 (No. 217-01921)	Apr-15
Reference Probe EX3DV4	SN: 3503	30-Dec-13 (No. EX3-3503_Dec13)	Dec-14
DAE4	SN: 601	18-Aug-14 (No. DAE4-601_Aug14)	Aug-15
Secondary Standards	ID #	Check Date (in house)	Scheduled Check
RF generator R&S SMT-06	100005	04-Aug-99 (in house check Oct-13)	In house check: Oct-16
Network Analyzer HP 8753E	US37390585 S4206	18-Oct-01 (in house check Oct-13)	In house check: Oct-14

Calibrated by: **Claudio Leubler** Name: Claudio Leubler Function: Laboratory Technician

Signature

Approved by: **Katja Pokovic** Name: Katja Pokovic Technical Manager

Issued: September 25, 2014

This calibration certificate shall not be reproduced except in full without written approval of the laboratory.

**Calibration Laboratory of
Schmid & Partner
Engineering AG**
Zeughausstrasse 43, 8004 Zurich, Switzerland



S Schweizerischer Kalibrierdienst
C Service suisse d'étalonnage
S Servizio svizzero di taratura
S Swiss Calibration Service

Accreditation No.: **SCS 108**

Accredited by the Swiss Accreditation Service (SAS)
The Swiss Accreditation Service is one of the signatories to the EA
Multilateral Agreement for the recognition of calibration certificates

Glossary:

TSL	tissue simulating liquid
ConvF	sensitivity in TSL / NORM x,y,z
N/A	not applicable or not measured

Calibration is Performed According to the Following Standards:

- IEC 62209-2, "Evaluation of Human Exposure to Radio Frequency Fields from Handheld and Body-Mounted Wireless Communication Devices in the Frequency Range of 30 MHz to 6 GHz: Human models, Instrumentation, and Procedures"; Part 2: "Procedure to determine the Specific Absorption Rate (SAR) for including accessories and multiple transmitters", March 2010
- KDB 865664, "SAR Measurement Requirements for 100 MHz to 6 GHz"
- IEEE Std 1528-2013, "IEEE Recommended Practice for Determining the Peak Spatial-Averaged Specific Absorption Rate (SAR) in the Human Head from Wireless Communications Devices: Measurement Techniques", June 2013

Additional Documentation:

- DASY4/5 System Handbook

Methods Applied and Interpretation of Parameters:

- Measurement Conditions:** Further details are available from the Validation Report at the end of the certificate. All figures stated in the certificate are valid at the frequency indicated.
- Antenna Parameters with TSL:** The dipole is mounted with the spacer to position its feed point exactly below the center marking of the flat phantom section, with the arms oriented parallel to the body axis.
- Feed Point Impedance and Return Loss:** These parameters are measured with the dipole positioned under the liquid filled phantom. The impedance stated is transformed from the measurement at the SMA connector to the feed point. The Return Loss ensures low reflected power. No uncertainty required.
- Electrical Delay:** One-way delay between the SMA connector and the antenna feed point. No uncertainty required.
- SAR measured:** SAR measured at the stated antenna input power.
- SAR normalized:** SAR as measured, normalized to an input power of 1 W at the antenna connector.
- SAR for nominal TSL parameters:** The measured TSL parameters are used to calculate the nominal SAR result.

The reported uncertainty of measurement is stated as the standard uncertainty of measurement multiplied by the coverage factor $k=2$, which for a normal distribution corresponds to a coverage probability of approximately 95%.

Measurement Conditions

DASY system configuration, as far as not given on page 1.

DASY Version	DASY5	V52.8.8
Extrapolation	Advanced Extrapolation	
Phantom	Modular Flat Phantom V5.0	
Distance Dipole Center - TSL	10 mm	with Spacer
Zoom Scan Resolution	dx, dy = 4.0 mm, dz = 1.4 mm	Graded Ratio = 1.4 (Z direction)
Frequency	5200 MHz ± 1 MHz 5300 MHz ± 1 MHz 5500 MHz ± 1 MHz 5600 MHz ± 1 MHz 5800 MHz ± 1 MHz	

Head TSL parameters at 5200 MHz

The following parameters and calculations were applied.

	Temperature	Permittivity	Conductivity
Nominal Head TSL parameters	22.0 °C	36.0	4.66 mho/m
Measured Head TSL parameters	(22.0 ± 0.2) °C	34.9 ± 6 %	4.54 mho/m ± 6 %
Head TSL temperature change during test	< 0.5 °C	----	----

SAR result with Head TSL at 5200 MHz

SAR averaged over 1 cm ³ (1 g) of Head TSL	Condition	
SAR measured	100 mW input power	8.17 W/kg
SAR for nominal Head TSL parameters	normalized to 1W	81.1 W/kg ± 19.9 % (k=2)

SAR averaged over 10 cm ³ (10 g) of Head TSL	condition	
SAR measured	100 mW input power	2.33 W/kg
SAR for nominal Head TSL parameters	normalized to 1W	23.1 W/kg ± 19.5 % (k=2)

Head TSL parameters at 5300 MHz

The following parameters and calculations were applied.

	Temperature	Permittivity	Conductivity
Nominal Head TSL parameters	22.0 °C	35.9	4.76 mho/m
Measured Head TSL parameters	(22.0 ± 0.2) °C	34.8 ± 6 %	4.64 mho/m ± 6 %
Head TSL temperature change during test	< 0.5 °C	----	----

SAR result with Head TSL at 5300 MHz

SAR averaged over 1 cm ³ (1 g) of Head TSL	Condition	
SAR measured	100 mW input power	8.64 W/kg
SAR for nominal Head TSL parameters	normalized to 1W	85.8 W / kg ± 19.9 % (k=2)

SAR averaged over 10 cm ³ (10 g) of Head TSL	condition	
SAR measured	100 mW input power	2.47 W/kg
SAR for nominal Head TSL parameters	normalized to 1W	24.5 W/kg ± 19.5 % (k=2)

Head TSL parameters at 5500 MHz

The following parameters and calculations were applied.

	Temperature	Permittivity	Conductivity
Nominal Head TSL parameters	22.0 °C	35.6	4.96 mho/m
Measured Head TSL parameters	(22.0 ± 0.2) °C	34.5 ± 6 %	4.83 mho/m ± 6 %
Head TSL temperature change during test	< 0.5 °C	----	----

SAR result with Head TSL at 5500 MHz

SAR averaged over 1 cm ³ (1 g) of Head TSL	Condition	
SAR measured	100 mW input power	8.93 W/kg
SAR for nominal Head TSL parameters	normalized to 1W	88.6 W/kg ± 19.9 % (k=2)

SAR averaged over 10 cm ³ (10 g) of Head TSL	condition	
SAR measured	100 mW input power	2.54 W/kg
SAR for nominal Head TSL parameters	normalized to 1W	25.2 W/kg ± 19.5 % (k=2)

Head TSL parameters at 5600 MHz

The following parameters and calculations were applied.

	Temperature	Permittivity	Conductivity
Nominal Head TSL parameters	22.0 °C	35.5	5.07 mho/m
Measured Head TSL parameters	(22.0 ± 0.2) °C	34.4 ± 6 %	4.93 mho/m ± 6 %
Head TSL temperature change during test	< 0.5 °C	----	----

SAR result with Head TSL at 5600 MHz

SAR averaged over 1 cm ³ (1 g) of Head TSL	Condition	
SAR measured	100 mW input power	8.76 W/kg
SAR for nominal Head TSL parameters	normalized to 1W	86.9 W/kg ± 19.9 % (k=2)

SAR averaged over 10 cm ³ (10 g) of Head TSL	condition	
SAR measured	100 mW input power	2.49 W/kg
SAR for nominal Head TSL parameters	normalized to 1W	24.7 W/kg ± 19.5 % (k=2)

Head TSL parameters at 5800 MHz

The following parameters and calculations were applied.

	Temperature	Permittivity	Conductivity
Nominal Head TSL parameters	22.0 °C	35.3	5.27 mho/m
Measured Head TSL parameters	(22.0 ± 0.2) °C	34.1 ± 6 %	5.14 mho/m ± 6 %
Head TSL temperature change during test	< 0.5 °C	----	----

SAR result with Head TSL at 5800 MHz

SAR averaged over 1 cm ³ (1 g) of Head TSL	Condition	
SAR measured	100 mW input power	8.30 W/kg
SAR for nominal Head TSL parameters	normalized to 1W	82.3 W/kg ± 19.9 % (k=2)

SAR averaged over 10 cm ³ (10 g) of Head TSL	condition	
SAR measured	100 mW input power	2.35 W/kg
SAR for nominal Head TSL parameters	normalized to 1W	23.3 W/kg ± 19.5 % (k=2)

Body TSL parameters at 5200 MHz

The following parameters and calculations were applied.

	Temperature	Permittivity	Conductivity
Nominal Body TSL parameters	22.0 °C	49.0	5.30 mho/m
Measured Body TSL parameters	(22.0 ± 0.2) °C	47.1 ± 6 %	5.40 mho/m ± 6 %
Body TSL temperature change during test	< 0.5 °C	----	----

SAR result with Body TSL at 5200 MHz

SAR averaged over 1 cm ³ (1 g) of Body TSL	Condition	
SAR measured	100 mW input power	7.84 W/kg
SAR for nominal Body TSL parameters	normalized to 1W	77.8 W/kg ± 19.9 % (k=2)

SAR averaged over 10 cm ³ (10 g) of Body TSL	condition	
SAR measured	100 mW input power	2.18 W/kg
SAR for nominal Body TSL parameters	normalized to 1W	21.6 W/kg ± 19.5 % (k=2)

Body TSL parameters at 5300 MHz

The following parameters and calculations were applied.

	Temperature	Permittivity	Conductivity
Nominal Body TSL parameters	22.0 °C	48.9	5.42 mho/m
Measured Body TSL parameters	(22.0 ± 0.2) °C	46.9 ± 6 %	5.53 mho/m ± 6 %
Body TSL temperature change during test	< 0.5 °C	----	----

SAR result with Body TSL at 5300 MHz

SAR averaged over 1 cm ³ (1 g) of Body TSL	Condition	
SAR measured	100 mW input power	8.05 W/kg
SAR for nominal Body TSL parameters	normalized to 1W	79.9 W/kg ± 19.9 % (k=2)

SAR averaged over 10 cm ³ (10 g) of Body TSL	condition	
SAR measured	100 mW input power	2.25 W/kg
SAR for nominal Body TSL parameters	normalized to 1W	22.3 W/kg ± 19.5 % (k=2)

Body TSL parameters at 5500 MHz

The following parameters and calculations were applied.

	Temperature	Permittivity	Conductivity
Nominal Body TSL parameters	22.0 °C	48.6	5.65 mho/m
Measured Body TSL parameters	(22.0 ± 0.2) °C	46.6 ± 6 %	5.79 mho/m ± 6 %
Body TSL temperature change during test	< 0.5 °C	----	----

SAR result with Body TSL at 5500 MHz

SAR averaged over 1 cm ³ (1 g) of Body TSL	Condition	
SAR measured	100 mW input power	8.37 W/kg
SAR for nominal Body TSL parameters	normalized to 1W	83.1 W/kg ± 19.9 % (k=2)

SAR averaged over 10 cm ³ (10 g) of Body TSL	condition	
SAR measured	100 mW input power	2.32 W/kg
SAR for nominal Body TSL parameters	normalized to 1W	23.0 W/kg ± 19.5 % (k=2)

Body TSL parameters at 5600 MHz

The following parameters and calculations were applied.

	Temperature	Permittivity	Conductivity
Nominal Body TSL parameters	22.0 °C	48.5	5.77 mho/m
Measured Body TSL parameters	(22.0 ± 0.2) °C	46.4 ± 6 %	5.93 mho/m ± 6 %
Body TSL temperature change during test	< 0.5 °C	----	----

SAR result with Body TSL at 5600 MHz

SAR averaged over 1 cm ³ (1 g) of Body TSL	Condition	
SAR measured	100 mW input power	8.48 W/kg
SAR for nominal Body TSL parameters	normalized to 1W	84.1 W/kg ± 19.9 % (k=2)

SAR averaged over 10 cm ³ (10 g) of Body TSL	condition	
SAR measured	100 mW input power	2.35 W/kg
SAR for nominal Body TSL parameters	normalized to 1W	23.3 W/kg ± 19.5 % (k=2)

Body TSL parameters at 5800 MHz

The following parameters and calculations were applied.

	Temperature	Permittivity	Conductivity
Nominal Body TSL parameters	22.0 °C	48.2	6.00 mho/m
Measured Body TSL parameters	(22.0 ± 0.2) °C	46.1 ± 6 %	6.21 mho/m ± 6 %
Body TSL temperature change during test	< 0.5 °C	----	----

SAR result with Body TSL at 5800 MHz

SAR averaged over 1 cm ³ (1 g) of Body TSL	Condition	
SAR measured	100 mW input power	7.86 W/kg
SAR for nominal Body TSL parameters	normalized to 1W	78.0 W/kg ± 19.9 % (k=2)

SAR averaged over 10 cm ³ (10 g) of Body TSL	condition	
SAR measured	100 mW input power	2.17 W/kg
SAR for nominal Body TSL parameters	normalized to 1W	21.5 W/kg ± 19.5 % (k=2)

Appendix (Additional assessments outside the scope of SCS108)

Antenna Parameters with Head TSL at 5200 MHz

Impedance, transformed to feed point	51.8 Ω - 9.9 j Ω
Return Loss	- 20.1 dB

Antenna Parameters with Head TSL at 5300 MHz

Impedance, transformed to feed point	54.5 Ω - 1.5 j Ω
Return Loss	- 26.8 dB

Antenna Parameters with Head TSL at 5500 MHz

Impedance, transformed to feed point	49.6 Ω - 2.0 j Ω
Return Loss	- 33.9 dB

Antenna Parameters with Head TSL at 5600 MHz

Impedance, transformed to feed point	56.5 Ω - 4.4 j Ω
Return Loss	- 22.7 dB

Antenna Parameters with Head TSL at 5800 MHz

Impedance, transformed to feed point	56.6 Ω + 4.4 j Ω
Return Loss	- 22.6 dB

Antenna Parameters with Body TSL at 5200 MHz

Impedance, transformed to feed point	51.9 Ω - 8.1 j Ω
Return Loss	- 21.8 dB

Antenna Parameters with Body TSL at 5300 MHz

Impedance, transformed to feed point	54.5 Ω + 0.1 j Ω
Return Loss	- 27.3 dB

Antenna Parameters with Body TSL at 5500 MHz

Impedance, transformed to feed point	50.2 Ω - 0.6 j Ω
Return Loss	- 43.8 dB

Antenna Parameters with Body TSL at 5600 MHz

Impedance, transformed to feed point	57.5 Ω - 3.2 j Ω
Return Loss	- 22.4 dB

Antenna Parameters with Body TSL at 5800 MHz

Impedance, transformed to feed point	57.2 Ω + 5.2 j Ω
Return Loss	- 21.7 dB

General Antenna Parameters and Design

Electrical Delay (one direction)	1.202 ns
----------------------------------	----------

After long term use with 100W radiated power, only a slight warming of the dipole near the feedpoint can be measured.

The dipole is made of standard semirigid coaxial cable. The center conductor of the feeding line is directly connected to the second arm of the dipole. The antenna is therefore short-circuited for DC-signals. On some of the dipoles, small end caps are added to the dipole arms in order to improve matching when loaded according to the position as explained in the "Measurement Conditions" paragraph. The SAR data are not affected by this change. The overall dipole length is still according to the Standard.

No excessive force must be applied to the dipole arms, because they might bend or the soldered connections near the feedpoint may be damaged.

Additional EUT Data

Manufactured by	SPEAG
Manufactured on	April 01, 2014

DASY5 Validation Report for Head TSL

Date: 25.09.2014

Test Laboratory: SPEAG, Zurich, Switzerland

DUT: Dipole 5GHz; Type: D5GHzV2; Serial: D5GHzV2 - SN:1191

Communication System: UID 0 - CW; Frequency: 5200 MHz, Frequency: 5300 MHz, Frequency: 5500 MHz, Frequency: 5600 MHz, Frequency: 5800 MHz

Medium parameters used: $f = 5200$ MHz; $\sigma = 4.54$ S/m; $\epsilon_r = 34.9$; $\rho = 1000$ kg/m³

Medium parameters used: $f = 5300$ MHz; $\sigma = 4.64$ S/m; $\epsilon_r = 34.8$; $\rho = 1000$ kg/m³

Medium parameters used: $f = 5500$ MHz; $\sigma = 4.83$ S/m; $\epsilon_r = 34.5$; $\rho = 1000$ kg/m³

Medium parameters used: $f = 5600$ MHz; $\sigma = 4.93$ S/m; $\epsilon_r = 34.4$; $\rho = 1000$ kg/m³

Medium parameters used: $f = 5800$ MHz; $\sigma = 5.14$ S/m; $\epsilon_r = 34.1$; $\rho = 1000$ kg/m³

Phantom section: Flat Section

Measurement Standard: DASY5 (IBEE/IEC/ANSI C63.19-2011)

DASY52 Configuration:

- Probe: EX3DV4 - SN3503; ConvF(5.52, 5.52, 5.52); Calibrated: 30.12.2013, ConvF(5.2, 5.2, 5.2); Calibrated: 30.12.2013, ConvF(5.01, 5.01, 5.01); Calibrated: 30.12.2013, ConvF(4.86, 4.86, 4.86); Calibrated: 30.12.2013, ConvF(4.91, 4.91, 4.91); Calibrated: 30.12.2013;
- Sensor-Surface: 1.4mm (Mechanical Surface Detection)
- Electronics: DAE4 Sn601; Calibrated: 18.08.2014
- Phantom: Flat Phantom 5.0 (front); Type: QD000P50AA; Serial: 1001
- DASY52 52.8.8(1222); SEMCAD X 14.6.10(7331)

Dipole Calibration for Head Tissue/Pin=100mW, dist=10mm, f=5200 MHz/Zoom Scan,

dist=1.4mm (8x8x7)/Cube 0: Measurement grid: dx=4mm, dy=4mm, dz=1.4mm

Reference Value = 65.20 V/m; Power Drift = 0.04 dB

Peak SAR (extrapolated) = 30.0 W/kg

SAR(1 g) = 8.17 W/kg; SAR(10 g) = 2.33 W/kg

Maximum value of SAR (measured) = 18.5 W/kg

Dipole Calibration for Head Tissue/Pin=100mW, dist=10mm, f=5300 MHz/Zoom Scan,

dist=1.4mm (8x8x7)/Cube 0: Measurement grid: dx=4mm, dy=4mm, dz=1.4mm

Reference Value = 65.90 V/m; Power Drift = 0.09 dB

Peak SAR (extrapolated) = 32.7 W/kg

SAR(1 g) = 8.64 W/kg; SAR(10 g) = 2.47 W/kg

Maximum value of SAR (measured) = 19.8 W/kg

Dipole Calibration for Head Tissue/Pin=100mW, dist=10mm, f=5500 MHz/Zoom Scan,

dist=1.4mm (8x8x7)/Cube 0: Measurement grid: dx=4mm, dy=4mm, dz=1.4mm

Reference Value = 65.91 V/m; Power Drift = 0.09 dB

Peak SAR (extrapolated) = 35.3 W/kg

SAR(1 g) = 8.93 W/kg; SAR(10 g) = 2.54 W/kg

Maximum value of SAR (measured) = 20.9 W/kg

Dipole Calibration for Head Tissue/Pin=100mW, dist=10mm, f=5600 MHz/Zoom Scan, dist=1.4mm (8x8x7)/Cube 0: Measurement grid: dx=4mm, dy=4mm, dz=1.4mm

Reference Value = 65.29 V/m; Power Drift = 0.07 dB

Peak SAR (extrapolated) = 34.8 W/kg

SAR(1 g) = 8.76 W/kg; SAR(10 g) = 2.49 W/kg

Maximum value of SAR (measured) = 20.7 W/kg

Dipole Calibration for Head Tissue/Pin=100mW, dist=10mm, f=5800 MHz/Zoom Scan, dist=1.4mm (8x8x7)/Cube 0: Measurement grid: dx=4mm, dy=4mm, dz=1.4mm

Reference Value = 62.74 V/m; Power Drift = 0.06 dB

Peak SAR (extrapolated) = 34.4 W/kg

SAR(1 g) = 8.3 W/kg; SAR(10 g) = 2.35 W/kg

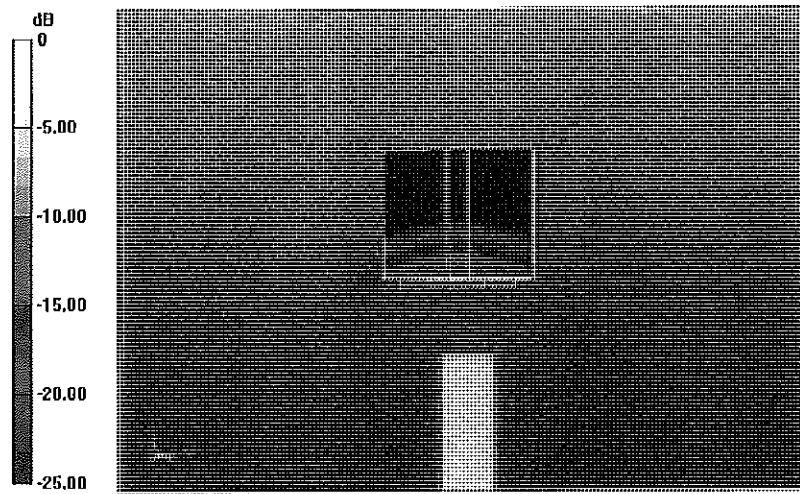

0 dB = 19.8 W/kg = 12.97 dBW/kg

Impedance Measurement Plot for Head TSL

25 Sep 2014 11:07:52

CH1 S11 1 U FS 1: 51.911 Ω -9.9180 Ω 3.0860 pF 5 200.000 000 MHz

*
Del
Cor
Avg
0
H1d

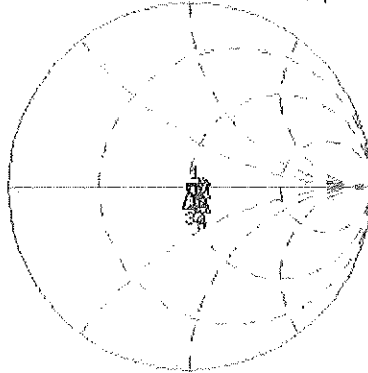

CH1 Markers

2: 54.518 Ω
-1.5078 Ω
5.30000 GHz
3: 49.566 Ω
-1.9707 Ω
5.50000 GHz
4: 56.516 Ω
-4.3633 Ω
5.60000 GHz
5: 56.555 Ω
4.3904 Ω
5.80000 GHz

CH2 S11 LOG 5 dB/REF -20 dB 1:-20.126 dB 5 200.000 000 MHz

Cor
Avg
0
H1d

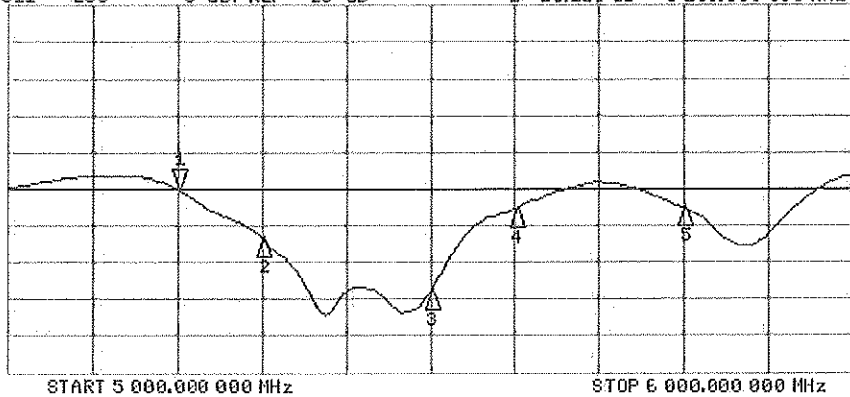

CH2 Markers

2: -26.825 dB
5.30000 GHz
3: -33.870 dB
5.50000 GHz
4: -22.660 dB
5.60000 GHz
5: -22.611 dB
5.80000 GHz

DASY5 Validation Report for Body TSL

Date: 24.09.2014

Test Laboratory: SPEAG, Zurich, Switzerland

DUT: Dipole 5GHz; Type: D5GHzV2; Serial: D5GHzV2 - SN:1191

Communication System: UID 0 - CW; Frequency: 5200 MHz, Frequency: 5300 MHz, Frequency: 5500 MHz, Frequency: 5600 MHz, Frequency: 5800 MHz

Medium parameters used: $f = 5200$ MHz; $\sigma = 5.4$ S/m; $\epsilon_r = 47.1$; $\rho = 1000$ kg/m³

Medium parameters used: $f = 5300$ MHz; $\sigma = 5.53$ S/m; $\epsilon_r = 46.9$; $\rho = 1000$ kg/m³

Medium parameters used: $f = 5500$ MHz; $\sigma = 5.79$ S/m; $\epsilon_r = 46.6$; $\rho = 1000$ kg/m³

Medium parameters used: $f = 5600$ MHz; $\sigma = 5.93$ S/m; $\epsilon_r = 46.4$; $\rho = 1000$ kg/m³

Medium parameters used: $f = 5800$ MHz; $\sigma = 6.21$ S/m; $\epsilon_r = 46.1$; $\rho = 1000$ kg/m³

Phantom section: Flat Section

Measurement Standard: DASY5 (IEBE/IEC/ANSI C63.19-2011)

DASY52 Configuration:

- Probe: EX3DV4 - SN3503; ConvF(5.01, 5.01, 5.01); Calibrated: 30.12.2013, ConvF(4.76, 4.76, 4.76); Calibrated: 30.12.2013, ConvF(4.52, 4.52, 4.52); Calibrated: 30.12.2013, ConvF(4.3, 4.3, 4.3); Calibrated: 30.12.2013, ConvF(4.47, 4.47, 4.47); Calibrated: 30.12.2013;
- Sensor-Surface: 1.4mm (Mechanical Surface Detection)
- Electronics: DAE4 Sn601; Calibrated: 18.08.2014
- Phantom: Flat Phantom 5.0 (back); Type: QD000P50AA; Serial: 1002
- DASY52 52.8.8(1222); SEMCAD X 14.6.10(7331)

Dipole Calibration for Body Tissue/Pin=100mW, dist=10mm, f=5200 MHz/Zoom Scan, dist=1.4mm (8x8x7)/Cube 0: Measurement grid: dx=4mm, dy=4mm, dz=1.4mm

Reference Value = 60.46 V/m; Power Drift = 0.02 dB

Peak SAR (extrapolated) = 30.7 W/kg

SAR(1 g) = 7.84 W/kg; SAR(10 g) = 2.18 W/kg

Maximum value of SAR (measured) = 18.5 W/kg

Dipole Calibration for Body Tissue/Pin=100mW, dist=10mm, f=5300 MHz/Zoom Scan, dist=1.4mm (8x8x7)/Cube 0: Measurement grid: dx=4mm, dy=4mm, dz=1.4mm

Reference Value = 60.42 V/m; Power Drift = 0.03 dB

Peak SAR (extrapolated) = 32.1 W/kg

SAR(1 g) = 8.05 W/kg; SAR(10 g) = 2.25 W/kg

Maximum value of SAR (measured) = 19.1 W/kg

Dipole Calibration for Body Tissue/Pin=100mW, dist=10mm, f=5500 MHz/Zoom Scan, dist=1.4mm (8x8x7)/Cube 0: Measurement grid: dx=4mm, dy=4mm, dz=1.4mm

Reference Value = 60.44 V/m; Power Drift = 0.02 dB

Peak SAR (extrapolated) = 35.8 W/kg

SAR(1 g) = 8.37 W/kg; SAR(10 g) = 2.32 W/kg

Maximum value of SAR (measured) = 20.4 W/kg

Dipole Calibration for Body Tissue/Pin=100mW, dist=10mm, f=5600 MHz/Zoom Scan, dist=1.4mm (8x8x7)/Cube 0: Measurement grid: dx=4mm, dy=4mm, dz=1.4mm
Reference Value = 60.44 V/m; Power Drift = 0.01 dB
Peak SAR (extrapolated) = 37.0 W/kg
SAR(1 g) = 8.48 W/kg; SAR(10 g) = 2.35 W/kg
Maximum value of SAR (measured) = 20.9 W/kg

Dipole Calibration for Body Tissue/Pin=100mW, dist=10mm, f=5800 MHz/Zoom Scan, dist=1.4mm (8x8x7)/Cube 0: Measurement grid: dx=4mm, dy=4mm, dz=1.4mm
Reference Value = 56.69 V/m; Power Drift = 0.01 dB
Peak SAR (extrapolated) = 36.4 W/kg
SAR(1 g) = 7.86 W/kg; SAR(10 g) = 2.17 W/kg
Maximum value of SAR (measured) = 19.7 W/kg

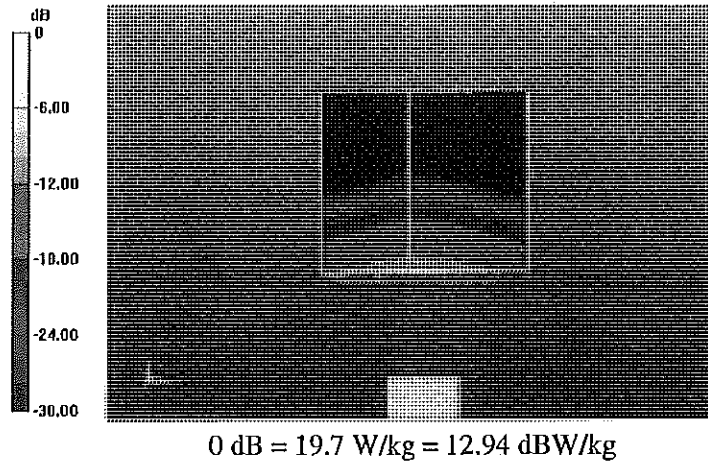

Impedance Measurement Plot for Body TSL

24 Sep 2014 11:05:50

[CH1] S11 1 U FS 1: 51.867 Ω -8.0566 Ω 3.7989 pF 5 200.000 000 MHz

Del
Cor
Avg
16
H1d

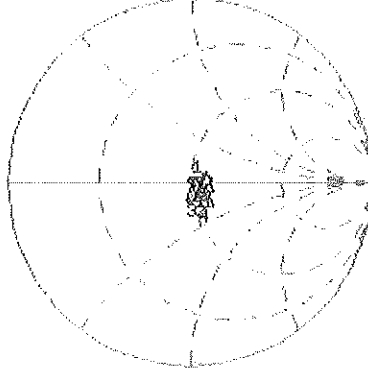

CH1 Markers

- 2: 54.531 Ω
0.1015 Ω
5.30000 GHz
- 3: 50.207 Ω
-613.28 pF
5.50000 GHz
- 4: 57.480 Ω
-3.1563 Ω
5.60000 GHz
- 5: 57.150 Ω
5.1934 Ω
5.80000 GHz

CH2 S11 LOG 5 dB/REF -20 dB 1: -21.835 dB 5 200.000 000 MHz

Cor
Avg
16
H1d

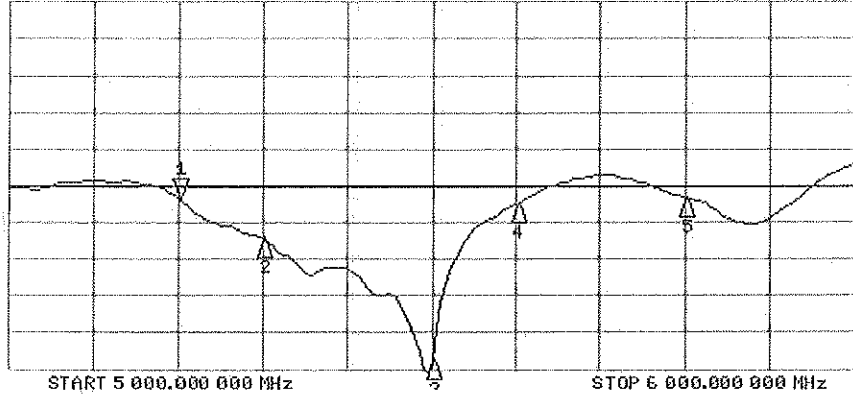

CH2 Markers

- 2: -27.251 dB
5.30000 GHz
- 3: -43.776 dB
5.50000 GHz
- 4: -22.442 dB
5.60000 GHz
- 5: -21.682 dB
5.80000 GHz

**Calibration Laboratory of
Schmid & Partner
Engineering AG**
Zeughausstrasse 43, 8004 Zurich, Switzerland



S Schweizerischer Kalibrierdienst
S Service suisse d'étalonnage
C Servizio svizzero di taratura
S Swiss Calibration Service

Accredited by the Swiss Accreditation Service (SAS)
The Swiss Accreditation Service is one of the signatories to the EA
Multilateral Agreement for the recognition of calibration certificates

Accreditation No.: **SCS 108**

Client **PC Test**

Certificate No: **ES3-3331_Aug14/2**

CALIBRATION CERTIFICATE (Replacement of No: ES3-3331_Aug14)

Object **ES3DV3 - SN:3331**

Calibration procedure(s) **QA CAL-01.v9, QA CAL-23.v5, QA CAL-25.v6
Calibration procedure for dosimetric E-field probes** CC
2014/14

Calibration date: **August 20, 2014**

This calibration certificate documents the traceability to national standards, which realize the physical units of measurements (SI).
The measurements and the uncertainties with confidence probability are given on the following pages and are part of the certificate.

All calibrations have been conducted in the closed laboratory facility: environment temperature (22 ± 3)°C and humidity < 70%.

Calibration Equipment used (M&TE critical for calibration)

Primary Standards	ID	Cal Date (Certificate No.)	Scheduled Calibration
Power meter E4419B	GB41293874	03-Apr-14 (No. 217-01911)	Apr-15
Power sensor E4412A	MY41498087	03-Apr-14 (No. 217-01911)	Apr-15
Reference 3 dB Attenuator	SN: S5054 (3c)	03-Apr-14 (No. 217-01915)	Apr-15
Reference 20 dB Attenuator	SN: S5277 (20x)	03-Apr-14 (No. 217-01919)	Apr-15
Reference 30 dB Attenuator	SN: S5129 (30b)	03-Apr-14 (No. 217-01920)	Apr-15
Reference Probe ES3DV2	SN: 3013	30-Dec-13 (No. ES3-3013_Dec13)	Dec-14
DAE4	SN: 660	13-Dec-13 (No. DAE4-660_Dec13)	Dec-14
Secondary Standards	ID	Check Date (in house)	Scheduled Check
RF generator HP 8648C	US3642U01700	4-Aug-99 (in house check Apr-13)	in house check: Apr-16
Network Analyzer HP 8753E	US37390585	18-Oct-01 (in house check Oct-13)	in house check: Oct-14

Calibrated by: **Name** Lelf Klysnar **Function** Laboratory Technician **Signature**

Approved by: **Name** Kalja Pokovic **Function** Technical Manager **Signature**

issued: November 3, 2014

This calibration certificate shall not be reproduced except in full without written approval of the laboratory.



Accredited by the Swiss Accreditation Service (SAS)
The Swiss Accreditation Service is one of the signatories to the EA
Multilateral Agreement for the recognition of calibration certificates

Accreditation No.: **SCS 108**

Glossary:

TSL	tissue simulating liquid
NORM _{x,y,z}	sensitivity in free space
ConvF	sensitivity in TSL / NORM _{x,y,z}
DCP	diode compression point
CF	crest factor (1/duty_cycle) of the RF signal
A, B, C, D	modulation dependent linearization parameters
Polarization φ	φ rotation around probe axis
Polarization ϑ	ϑ rotation around an axis that is in the plane normal to probe axis (at measurement center), i.e., $\vartheta = 0$ is normal to probe axis
Connector Angle	information used in DASY system to align probe sensor X to the robot coordinate system

Calibration is Performed According to the Following Standards:

- a) IEEE Std 1528-2013, "IEEE Recommended Practice for Determining the Peak Spatial-Averaged Specific Absorption Rate (SAR) in the Human Head from Wireless Communications Devices: Measurement Techniques", June 2013
- b) IEC 62209-1, "Procedure to measure the Specific Absorption Rate (SAR) for hand-held devices used in close proximity to the ear (frequency range of 300 MHz to 3 GHz)", February 2005

Methods Applied and Interpretation of Parameters:

- **NORM_{x,y,z}**: Assessed for E-field polarization $\vartheta = 0$ ($f \leq 900$ MHz in TEM-cell; $f > 1800$ MHz: R22 waveguide). NORM_{x,y,z} are only intermediate values, i.e., the uncertainties of NORM_{x,y,z} does not affect the E²-field uncertainty inside TSL (see below ConvF).
- **NORM(f)_{x,y,z}** = NORM_{x,y,z} * frequency_response (see Frequency Response Chart). This linearization is implemented in DASY4 software versions later than 4.2. The uncertainty of the frequency response is included in the stated uncertainty of ConvF.
- **DCP_{x,y,z}**: DCP are numerical linearization parameters assessed based on the data of power sweep with CW signal (no uncertainty required). DCP does not depend on frequency nor media.
- **PAR**: PAR is the Peak to Average Ratio that is not calibrated but determined based on the signal characteristics
- **A_{x,y,z}; B_{x,y,z}; C_{x,y,z}; D_{x,y,z}; VR_{x,y,z}**: A, B, C, D are numerical linearization parameters assessed based on the data of power sweep for specific modulation signal. The parameters do not depend on frequency nor media. VR is the maximum calibration range expressed in RMS voltage across the diode.
- **ConvF and Boundary Effect Parameters**: Assessed in flat phantom using E-field (or Temperature Transfer Standard for $f \leq 800$ MHz) and inside waveguide using analytical field distributions based on power measurements for $f > 800$ MHz. The same setups are used for assessment of the parameters applied for boundary compensation (alpha, depth) of which typical uncertainty values are given. These parameters are used in DASY4 software to improve probe accuracy close to the boundary. The sensitivity in TSL corresponds to NORM_{x,y,z} * ConvF whereby the uncertainty corresponds to that given for ConvF. A frequency dependent ConvF is used in DASY version 4.4 and higher which allows extending the validity from ± 50 MHz to ± 100 MHz.
- **Spherical isotropy (3D deviation from isotropy)**: In a field of low gradients realized using a flat phantom exposed by a patch antenna.
- **Sensor Offset**: The sensor offset corresponds to the offset of virtual measurement center from the probe tip (on probe axis). No tolerance required.
- **Connector Angle**: The angle is assessed using the information gained by determining the NORM_x (no uncertainty required).

Probe ES3DV3

SN:3331

Manufactured: January 24, 2012
Calibrated: August 20, 2014

Calibrated for DASY/EASY Systems
(Note: non-compatible with DASY2 system!)

DASY/EASY - Parameters of Probe: ES3DV3 - SN:3331

Basic Calibration Parameters

	Sensor X	Sensor Y	Sensor Z	Unc (k=2)
Norm ($\mu V/(V/m)^2$) ^A	1.16	1.22	0.65	$\pm 10.1\%$
DCP (mV) ^B	97.2	104.5	101.6	

Modulation Calibration Parameters

UID	Communication System Name		A dB	B dB $\sqrt{\mu V}$	C	D dB	VR mV	Unc ^E (k=2)
0	CW	X	0.0	0.0	1.0	0.00	196.9	$\pm 2.7\%$
		Y	0.0	0.0	1.0		202.0	
		Z	0.0	0.0	1.0		182.4	
10010-CAA	SAR Validation (Square, 100ms, 10ms)	X	3.20	62.4	12.3	10.00	41.8	$\pm 1.7\%$
		Y	3.15	62.4	12.1		43.7	
		Z	36.65	88.0	19.5		35.8	
10011-CAB	UMTS-FDD (WCDMA)	X	3.03	63.8	15.9	2.91	133.8	$\pm 0.9\%$
		Y	3.28	67.2	18.6		140.9	
		Z	3.32	66.8	18.3		146.0	
10012-CAA	IEEE 802.11b WiFi 2.4 GHz (DSSS, 1 Mbps)	X	2.51	63.6	15.0	1.87	134.4	$\pm 0.9\%$
		Y	3.11	69.9	19.3		144.5	
		Z	2.92	68.3	18.4		145.1	
10013-CAA	IEEE 802.11g WiFi 2.4 GHz (DSSS-OFDM, 6 Mbps)	X	11.32	70.3	22.8	9.46	135.4	$\pm 3.5\%$
		Y	11.79	72.2	24.2		146.6	
		Z	11.30	70.4	22.8		145.6	
10021-DAB	GSM-FDD (TDMA, GMSK)	X	11.03	85.1	23.4	9.39	127.4	$\pm 2.2\%$
		Y	25.94	99.5	28.1		119.9	
		Z	11.02	88.4	24.4		123.1	
10023-DAB	GPRS-FDD (TDMA, GMSK, TN 0)	X	12.84	87.5	24.3	9.57	138.6	$\pm 2.5\%$
		Y	26.90	99.8	28.2		146.7	
		Z	10.27	87.7	24.4		113.6	
10024-DAB	GPRS-FDD (TDMA, GMSK, TN 0-1)	X	14.52	85.4	20.8	6.56	149.8	$\pm 2.2\%$
		Y	38.05	99.6	25.4		119.6	
		Z	31.13	99.9	25.4		147.0	
10027-DAB	GPRS-FDD (TDMA, GMSK, TN 0-1-2)	X	6.94	75.0	16.0	4.80	136.5	$\pm 1.7\%$
		Y	55.93	99.7	23.3		134.0	
		Z	38.81	99.8	23.8		145.4	
10028-DAB	GPRS-FDD (TDMA, GMSK, TN 0-1-2-3)	X	4.68	71.0	13.6	3.55	149.6	$\pm 1.7\%$
		Y	58.60	99.9	22.7		140.1	
		Z	41.15	99.6	22.7		129.1	
10032-CAA	IEEE 802.15.1 Bluetooth (GFSK, DH5)	X	1.18	62.6	8.4	1.16	134.1	$\pm 1.7\%$
		Y	81.15	99.6	19.6		149.1	
		Z	50.90	99.9	20.1		142.0	
10039-CAB	CDMA2000 (1xRTT, RC1)	X	4.57	64.6	17.2	4.57	130.2	$\pm 1.4\%$
		Y	4.83	67.2	19.3		145.2	
		Z	4.79	66.5	18.8		141.3	

10081-CAB	CDMA2000 (1xRTT, RC3)	X	3.91	64.7	17.0	3.97	148.6	±1.4 %
		Y	3.94	66.4	18.7		139.3	
		Z	3.93	65.9	18.3		136.4	
10098-CAB	UMTS-FDD (HSUPA, Subtest 2)	X	4.42	64.7	16.9	3.98	138.2	±1.2 %
		Y	4.53	66.5	18.6		128.9	
		Z	4.60	66.3	18.3		127.5	
10100-CAB	LTE-FDD (SC-FDMA, 100% RB, 20 MHz, QPSK)	X	6.39	66.6	18.8	5.67	143.8	±1.9 %
		Y	6.42	67.7	19.9		134.4	
		Z	6.37	66.9	19.2		132.5	
10108-CAB	LTE-FDD (SC-FDMA, 100% RB, 10 MHz, QPSK)	X	6.27	66.1	18.6	5.80	140.5	±1.9 %
		Y	6.27	67.1	19.7		132.3	
		Z	6.27	66.5	19.1		131.1	
10110-CAB	LTE-FDD (SC-FDMA, 100% RB, 5 MHz, QPSK)	X	5.98	65.6	18.4	5.75	137.0	±1.9 %
		Y	5.98	66.8	19.6		129.1	
		Z	5.98	66.2	19.1		128.1	
10114-CAA	IEEE 802.11n (HT Greenfield, 13.5 Mbps, BPSK)	X	10.08	68.1	20.6	8.10	131.5	±3.3 %
		Y	10.54	69.9	22.0		148.4	
		Z	10.46	69.1	21.2		149.0	
10117-CAA	IEEE 802.11n (HT Mixed, 13.5 Mbps, BPSK)	X	10.12	68.2	20.6	8.07	132.9	±2.7 %
		Y	10.54	69.9	21.9		149.5	
		Z	10.04	68.1	20.6		123.5	
10151-CAB	LTE-TDD (SC-FDMA, 50% RB, 20 MHz, QPSK)	X	10.07	74.1	24.8	9.28	135.5	±3.8 %
		Y	10.33	76.0	26.3		123.9	
		Z	9.05	71.9	23.9		145.1	
10154-CAB	LTE-FDD (SC-FDMA, 50% RB, 10 MHz, QPSK)	X	5.96	65.6	18.4	5.75	137.0	±1.9 %
		Y	5.93	66.5	19.4		128.7	
		Z	6.00	66.2	19.1		129.9	
10160-CAB	LTE-FDD (SC-FDMA, 50% RB, 15 MHz, QPSK)	X	6.41	66.2	18.7	5.82	141.3	±1.9 %
		Y	6.42	67.3	19.8		133.3	
		Z	6.45	66.8	19.3		133.9	
10169-CAB	LTE-FDD (SC-FDMA, 1 RB, 20 MHz, QPSK)	X	5.01	65.6	18.5	5.73	139.9	±1.7 %
		Y	5.00	66.9	19.8		133.5	
		Z	4.88	66.1	19.2		132.6	
10172-CAB	LTE-TDD (SC-FDMA, 1 RB, 20 MHz, QPSK)	X	9.20	77.8	26.8	9.21	149.1	±3.8 %
		Y	11.00	84.2	30.5		140.6	
		Z	7.06	72.2	24.3		129.4	
10175-CAB	LTE-FDD (SC-FDMA, 1 RB, 10 MHz, QPSK)	X	4.93	65.2	18.3	5.72	131.8	±1.7 %
		Y	5.03	67.0	19.9		133.9	
		Z	4.97	66.5	19.4		148.0	
10181-CAB	LTE-FDD (SC-FDMA, 1 RB, 15 MHz, QPSK)	X	4.97	65.4	18.3	5.72	137.6	±1.9 %
		Y	5.01	66.9	19.8		133.3	
		Z	4.96	66.5	19.4		146.6	
10193-CAA	IEEE 802.11n (HT Greenfield, 6.5 Mbps, BPSK)	X	9.74	67.7	20.4	8.09	123.4	±3.0 %
		Y	10.16	69.5	21.8		142.8	
		Z	10.03	68.5	21.0		136.4	

10196-CAA	IEEE 802.11n (HT Mixed, 6.5 Mbps, BPSK)	X	9.71	67.7	20.4	8.10	124.5	±3.0 %
		Y	10.16	69.5	21.9		144.1	
		Z	10.17	68.9	21.2		146.1	
10219-CAA	IEEE 802.11n (HT Mixed, 7.2 Mbps, BPSK)	X	9.59	67.5	20.3	8.03	123.8	±3.0 %
		Y	10.07	69.5	21.8		143.7	
		Z	10.08	68.9	21.2		145.5	
10222-CAA	IEEE 802.11n (HT Mixed, 15 Mbps, BPSK)	X	10.01	68.0	20.5	8.06	129.1	±2.7 %
		Y	10.16	69.0	21.4		123.7	
		Z	10.02	68.1	20.7		123.3	
10225-CAB	UMTS-FDD (HSPA+)	X	6.84	65.7	18.3	5.97	128.3	±1.7 %
		Y	7.10	67.5	19.8		145.9	
		Z	7.17	67.2	19.4		146.7	
10237-CAB	LTE-TDD (SC-FDMA, 1 RB, 10 MHz, QPSK)	X	9.23	77.8	26.8	9.21	149.7	±4.1 %
		Y	11.46	85.4	31.1		143.6	
		Z	7.17	72.6	24.5		132.3	
10252-CAB	LTE-TDD (SC-FDMA, 50% RB, 10 MHz, QPSK)	X	9.84	74.4	25.0	9.24	143.3	±4.1 %
		Y	11.53	80.3	28.7		147.8	
		Z	8.43	71.1	23.5		136.1	
10267-CAB	LTE-TDD (SC-FDMA, 100% RB, 10 MHz, QPSK)	X	9.60	72.7	24.1	9.30	124.1	±3.5 %
		Y	10.50	76.3	26.6		125.1	
		Z	9.07	72.0	23.9		144.3	
10274-CAB	UMTS-FDD (HSUPA, Subtest 5, 3GPP Rel8.10)	X	5.95	66.0	18.0	4.87	147.1	±1.7 %
		Y	6.00	67.2	19.2		139.8	
		Z	6.11	67.0	18.9		140.5	
10275-CAB	UMTS-FDD (HSUPA, Subtest 5, 3GPP Rel8.4)	X	4.17	64.3	16.7	3.96	129.0	±1.2 %
		Y	4.50	67.3	19.1		144.7	
		Z	4.48	66.8	18.5		141.5	
10291-AAB	CDMA2000, RC3, SO55, Full Rate	X	3.50	64.4	16.6	3.46	142.1	±1.2 %
		Y	3.69	67.2	19.0		134.8	
		Z	3.67	66.6	18.5		130.8	
10292-AAB	CDMA2000, RC3, SO32, Full Rate	X	3.45	64.5	16.5	3.39	145.2	±1.2 %
		Y	3.64	67.3	19.0		135.9	
		Z	3.66	67.0	18.7		133.8	
10297-AAA	LTE-FDD (SC-FDMA, 50% RB, 20 MHz, QPSK)	X	6.28	66.1	18.6	5.81	139.0	±1.9 %
		Y	6.28	67.2	19.8		130.1	
		Z	6.29	66.6	19.2		128.4	
10311-AAA	LTE-FDD (SC-FDMA, 100% RB, 15 MHz, QPSK)	X	6.86	66.8	19.1	6.06	144.5	±1.9 %
		Y	6.89	67.9	20.2		135.9	
		Z	6.88	67.3	19.6		135.0	
10315-AAA	IEEE 802.11b WIFI 2.4 GHz (DSSS, 1 Mbps, 96pc duty cycle)	X	2.32	63.0	14.7	1.71	128.7	±0.7 %
		Y	3.14	71.0	20.1		142.2	
		Z	2.95	69.2	18.9		142.4	
10316-AAA	IEEE 802.11g WIFI 2.4 GHz (ERP-OFDM, 6 Mbps, 96pc duty cycle)	X	9.99	68.0	20.8	8.36	125.5	±3.3 %
		Y	10.41	69.8	22.2		141.5	
		Z	10.36	69.1	21.4		143.6	

10403-AAB	CDMA2000 (1xEV-DO, Rev. 0)	X	4.41	65.2	16.6	3.76	135.0	±0.9 %
		Y	4.81	68.3	19.0		149.0	
		Z	4.82	68.1	18.7		150.0	
10404-AAB	CDMA2000 (1xEV-DO, Rev. A)	X	4.31	65.1	16.6	3.77	131.6	±0.9 %
		Y	4.71	68.2	19.0		146.2	
		Z	4.86	68.7	19.0		147.0	
10415-AAA	IEEE 802.11b WiFi 2.4 GHz (DSSS, 1 Mbps, 99pc duty cycle)	X	2.13	62.1	14.2	1.54	128.1	±0.7 %
		Y	2.65	68.6	19.0		142.6	
		Z	2.74	68.5	18.7		143.2	
10416-AAA	IEEE 802.11g WiFi 2.4 GHz (ERP-OFDM, 6 Mbps, 99pc duty cycle)	X	9.84	67.8	20.6	8.23	125.2	±3.0 %
		Y	10.22	69.5	21.9		142.0	
		Z	10.23	68.9	21.3		144.4	

The reported uncertainty of measurement is stated as the standard uncertainty of measurement multiplied by the coverage factor $k=2$, which for a normal distribution corresponds to a coverage probability of approximately 95%.

^A The uncertainties of Norm X, Y, Z do not affect the E^2 -field uncertainty inside TSL (see Pages 8 and 9).

^B Numerical linearization parameter; uncertainty not required.

^E Uncertainty is determined using the max. deviation from linear response applying rectangular distribution and is expressed for the square of the field value.

DASY/EASY - Parameters of Probe: ES3DV3 - SN:3331

Calibration Parameter Determined in Head Tissue Simulating Media

f (MHz) ^c	Relative Permittivity ^F	Conductivity (S/m) ^F	ConvF X	ConvF Y	ConvF Z	Alpha ^g	Depth ^g (mm)	Unct. (k=2)
750	41.9	0.89	6.47	6.47	6.47	0.48	1.48	± 12.0 %
835	41.5	0.90	6.24	6.24	6.24	0.30	1.98	± 12.0 %
1750	40.1	1.37	5.28	5.28	5.28	0.75	1.19	± 12.0 %
1900	40.0	1.40	5.09	5.09	5.09	0.80	1.16	± 12.0 %
2450	39.2	1.80	4.48	4.48	4.48	0.70	1.32	± 12.0 %
2600	39.0	1.96	4.38	4.38	4.38	0.80	1.29	± 12.0 %

^c Frequency validity above 300 MHz of ± 100 MHz only applies for DASY v4.4 and higher (see Page 2), else it is restricted to ± 50 MHz. The uncertainty is the RSS of the ConvF uncertainty at calibration frequency and the uncertainty for the indicated frequency band. Frequency validity below 300 MHz is ± 10, 25, 40, 50 and 70 MHz for ConvF assessments at 30, 64, 128, 150 and 220 MHz respectively. Above 5 GHz frequency validity can be extended to ± 110 MHz.

^f At frequencies below 3 GHz, the validity of tissue parameters (ϵ and σ) can be relaxed to ± 10% if liquid compensation formula is applied to measured SAR values. At frequencies above 3 GHz, the validity of tissue parameters (ϵ and σ) is restricted to ± 5%. The uncertainty is the RSS of the ConvF uncertainty for indicated target tissue parameters.

^g Alpha/Depth are determined during calibration. SPEAG warrants that the remaining deviation due to the boundary effect after compensation is always less than ± 1% for frequencies below 3 GHz and below ± 2% for frequencies between 3-6 GHz at any distance larger than half the probe tip diameter from the boundary.

DASY/EASY - Parameters of Probe: ES3DV3 - SN:3331

Calibration Parameter Determined in Body Tissue Simulating Media

f (MHz) ^c	Relative Permittivity ^f	Conductivity (S/m) ^f	ConvF X	ConvF Y	ConvF Z	Alpha ^g	Depth ^g (mm)	Unct. (k=2)
750	55.5	0.96	6.12	6.12	6.12	0.64	1.30	± 12.0 %
835	55.2	0.97	6.14	6.14	6.14	0.80	1.14	± 12.0 %
1750	53.4	1.49	4.93	4.93	4.93	0.46	1.67	± 12.0 %
1900	53.3	1.52	4.73	4.73	4.73	0.44	1.72	± 12.0 %
2450	52.7	1.95	4.29	4.29	4.29	0.71	0.98	± 12.0 %
2600	52.5	2.16	4.23	4.23	4.23	0.68	1.00	± 12.0 %

^c Frequency validity above 300 MHz of ± 100 MHz only applies for DASY v4.4 and higher (see Page 2), else it is restricted to ± 50 MHz. The uncertainty is the RSS of the ConvF uncertainty at calibration frequency and the uncertainty for the indicated frequency band. Frequency validity below 300 MHz is ± 10, 25, 40, 50 and 70 MHz for ConvF assessments at 30, 64, 128, 150 and 220 MHz respectively. Above 5 GHz frequency validity can be extended to ± 110 MHz.

^f At frequencies below 3 GHz, the validity of tissue parameters (ϵ and σ) can be relaxed to ± 10% if liquid compensation formula is applied to measured SAR values. At frequencies above 3 GHz, the validity of tissue parameters (ϵ and σ) is restricted to ± 5%. The uncertainty is the RSS of the ConvF uncertainty for indicated target tissue parameters.

^g Alpha/Depth are determined during calibration. SPEAG warrants that the remaining deviation due to the boundary effect after compensation is always less than ± 1% for frequencies below 3 GHz and below ± 2% for frequencies between 3-6 GHz at any distance larger than half the probe tip diameter from the boundary.

Frequency Response of E-Field (TEM-Cell: ifi110 EXX, Waveguide: R22)

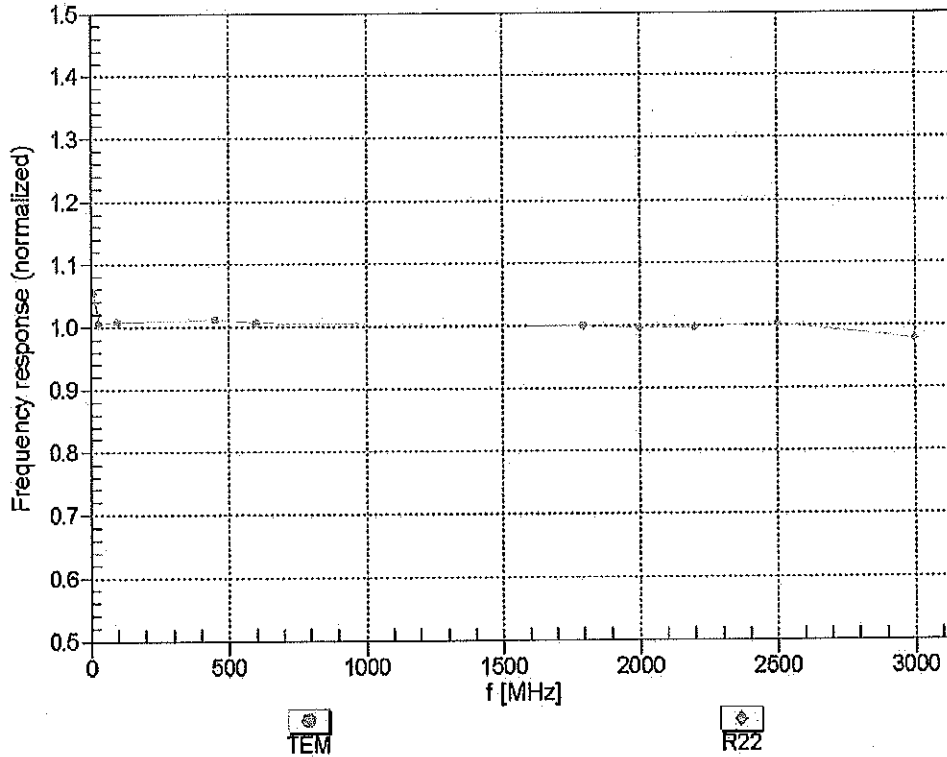

Uncertainty of Frequency Response of E-field: $\pm 6.3\%$ ($k=2$)

Receiving Pattern (ϕ), $\theta = 0^\circ$

f=600 MHz, TEM

f=1800 MHz, R22

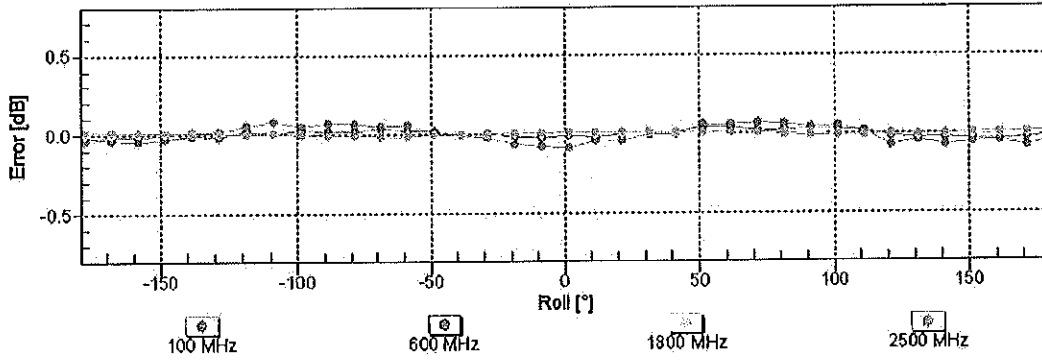
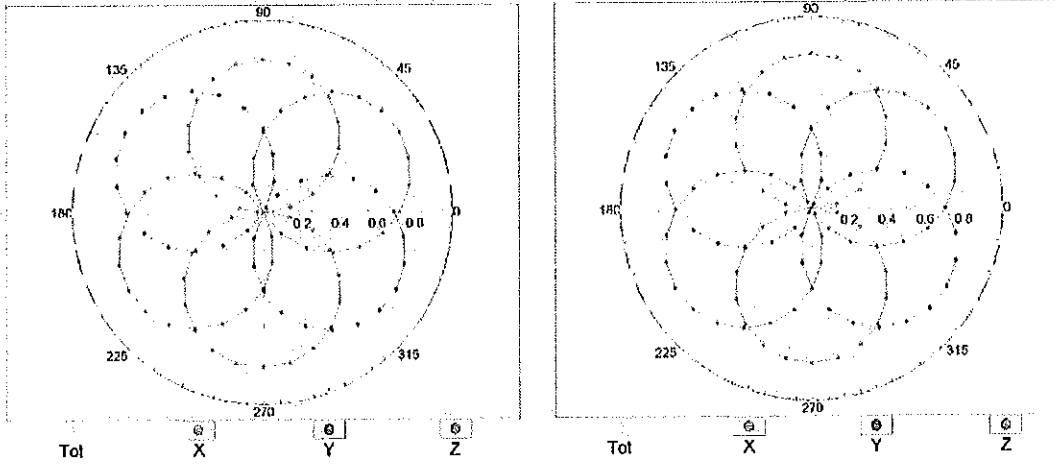

Uncertainty of Axial Isotropy Assessment: $\pm 0.5\%$ ($k=2$)

Dynamic Range f(SAR_{head}) (TEM cell , f_{eval}= 1900 MHz)

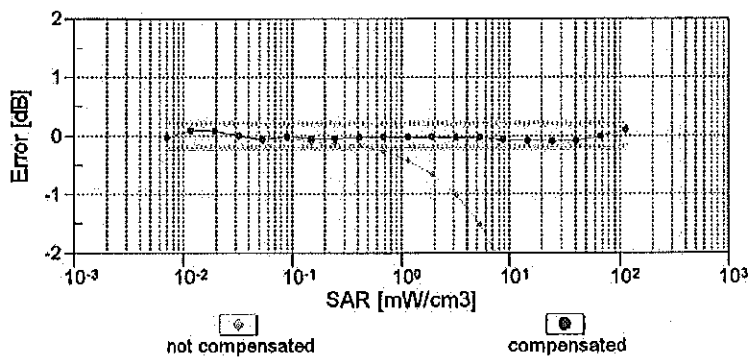
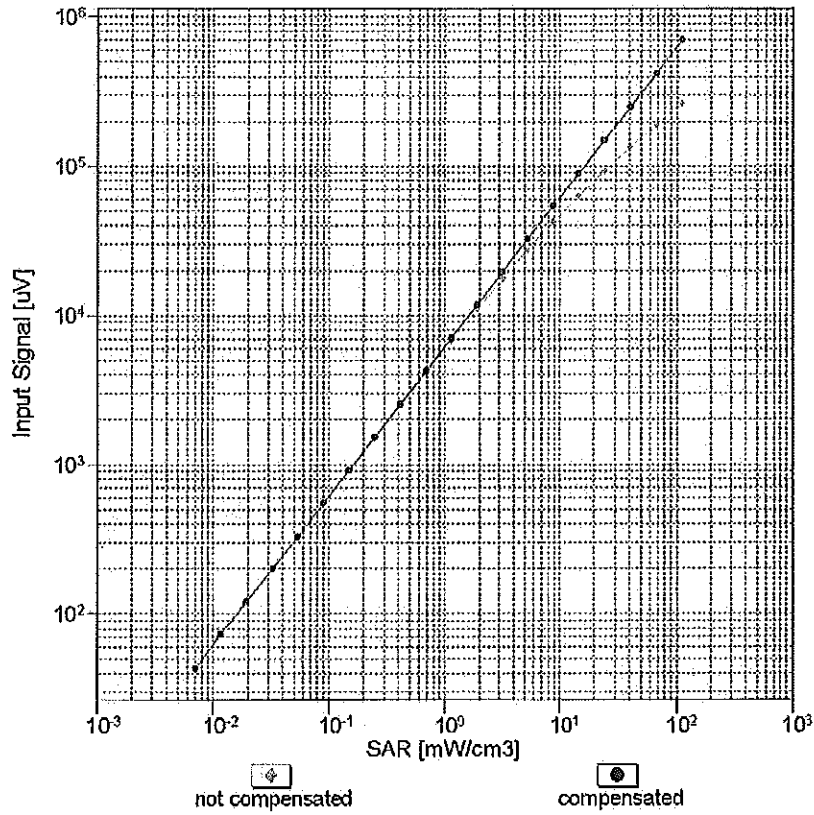

Uncertainty of Linearity Assessment: ± 0.6% (k=2)

Conversion Factor Assessment

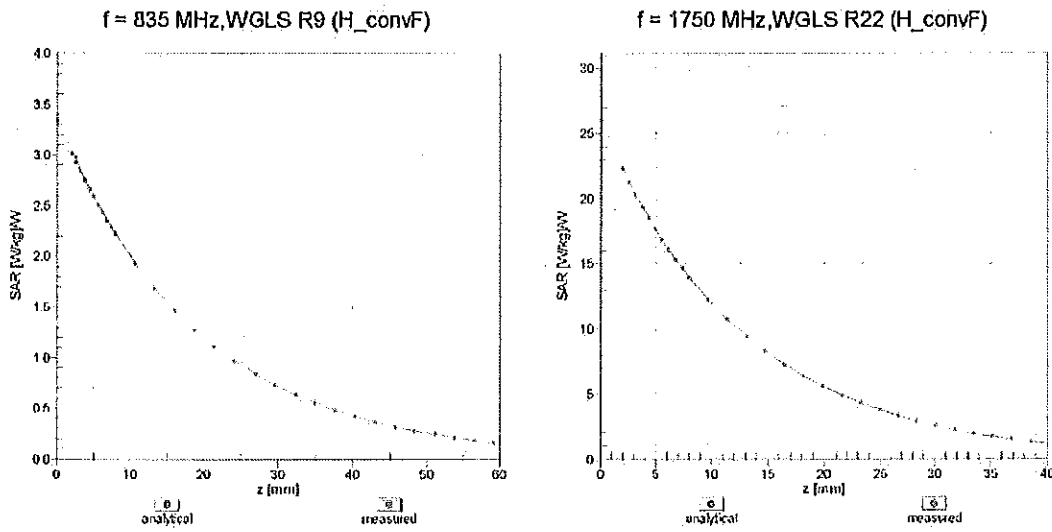

Deviation from Isotropy in Liquid Error (ϕ, θ), f = 900 MHz

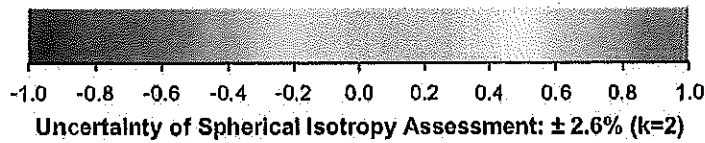
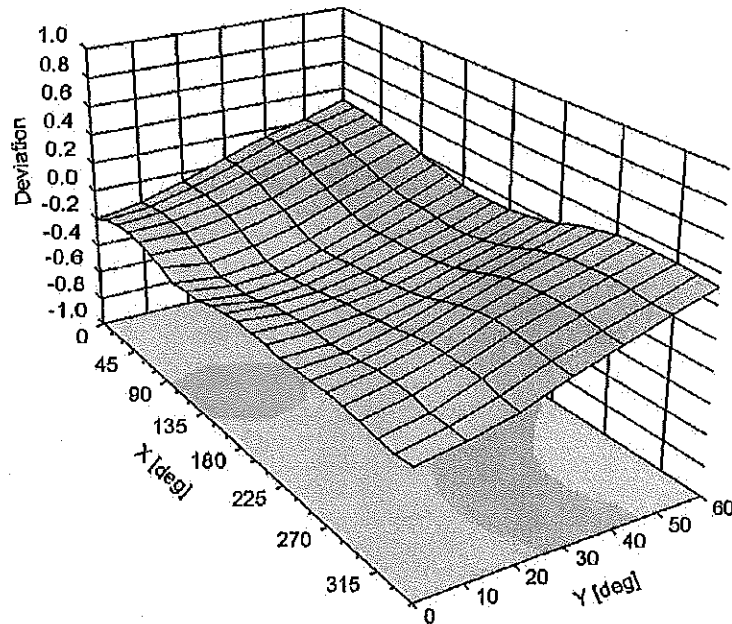

DASY/EASY - Parameters of Probe: ES3DV3 - SN:3331**Other Probe Parameters**

Sensor Arrangement	Triangular
Connector Angle (°)	-108.5
Mechanical Surface Detection Mode	enabled
Optical Surface Detection Mode	disabled
Probe Overall Length	337 mm
Probe Body Diameter	10 mm
Tip Length	10 mm
Tip Diameter	4 mm
Probe Tip to Sensor X Calibration Point	2 mm
Probe Tip to Sensor Y Calibration Point	2 mm
Probe Tip to Sensor Z Calibration Point	2 mm
Recommended Measurement Distance from Surface	3 mm

**Calibration Laboratory of
Schmid & Partner
Engineering AG**
Zeughausstrasse 43, 8004 Zurich, Switzerland



S Schweizerischer Kalibrierdienst
S Service suisse d'étalonnage
C Servizio svizzero di taratura
S Swiss Calibration Service

Accredited by the Swiss Accreditation Service (SAS)
The Swiss Accreditation Service is one of the signatories to the EA
Multilateral Agreement for the recognition of calibration certificates

Accreditation No.: **SCS 108**

Client **PC Test**

Certificate No: **ES3-3334_Dec14**

CALIBRATION CERTIFICATE

Object **ES3DV3 - SN:3334**

Calibration procedure(s) **QA CAL-01.v9, QA CAL-23.v5, QA CAL-25.v6
Calibration procedure for dosimetric E-field probes**

CC
12/16/14

Calibration date: **December 16, 2014**

This calibration certificate documents the traceability to national standards, which realize the physical units of measurements (SI).
The measurements and the uncertainties with confidence probability are given on the following pages and are part of the certificate.

All calibrations have been conducted in the closed laboratory facility: environment temperature (22 ± 3)°C and humidity < 70%.

Calibration Equipment used (M&TE critical for calibration)

Primary Standards	ID	Cal Date (Certificate No.)	Scheduled Calibration
Power meter E4419B	GB41293874	03-Apr-14 (No. 217-01911)	Apr-15
Power sensor E4412A	MY41498087	03-Apr-14 (No. 217-01911)	Apr-15
Reference 3 dB Attenuator	SN: S5054 (3c)	03-Apr-14 (No. 217-01915)	Apr-15
Reference 20 dB Attenuator	SN: S5277 (20x)	03-Apr-14 (No. 217-01919)	Apr-15
Reference 30 dB Attenuator	SN: S5129 (30b)	03-Apr-14 (No. 217-01920)	Apr-15
Reference Probe ES3DV2	SN: 3013	30-Dec-13 (No. ES3-3013_Dec13)	Dec-14
DAE4	SN: 789	30-Apr-14 (No. DAE4-789_Apr14)	Apr-15
Secondary Standards	ID	Check Date (in house)	Scheduled Check
RF generator HP 8648C	US3642U01700	4-Aug-99 (in house check Apr-13)	In house check: Apr-16
Network Analyzer HP 8753E	US37390585	18-Oct-01 (in house check Oct-14)	In house check: Oct-15

	Name	Function	Signature
Calibrated by:	Leif Klysner	Laboratory Technician	
Approved by:	Katja Pokovic	Technical Manager	
			Issued: December 16, 2014
This calibration certificate shall not be reproduced except in full without written approval of the laboratory.			



Accredited by the Swiss Accreditation Service (SAS)
The Swiss Accreditation Service is one of the signatories to the EA
Multilateral Agreement for the recognition of calibration certificates

Accreditation No.: **SCS 108**

Glossary:

TSL	tissue simulating liquid
NORM _{x,y,z}	sensitivity in free space
ConvF	sensitivity in TSL / NORM _{x,y,z}
DCP	diode compression point
CF	crest factor (1/duty_cycle) of the RF signal
A, B, C, D	modulation dependent linearization parameters
Polarization ϕ	ϕ rotation around probe axis
Polarization ϑ	ϑ rotation around an axis that is in the plane normal to probe axis (at measurement center), i.e., $\vartheta = 0$ is normal to probe axis
Connector Angle	Information used in DASY system to align probe sensor X to the robot coordinate system

Calibration is Performed According to the Following Standards:

- a) IEEE Std 1528-2013, "IEEE Recommended Practice for Determining the Peak Spatial-Averaged Specific Absorption Rate (SAR) in the Human Head from Wireless Communications Devices: Measurement Techniques", June 2013
- b) IEC 62209-1, "Procedure to measure the Specific Absorption Rate (SAR) for hand-held devices used in close proximity to the ear (frequency range of 300 MHz to 3 GHz)", February 2005

Methods Applied and Interpretation of Parameters:

- **NORM_{x,y,z}**: Assessed for E-field polarization $\vartheta = 0$ ($f \leq 900$ MHz in TEM-cell; $f > 1800$ MHz: R22 waveguide). NORM_{x,y,z} are only intermediate values, i.e., the uncertainties of NORM_{x,y,z} does not affect the E²-field uncertainty inside TSL (see below ConvF).
- **NORM(f)_{x,y,z} = NORM_{x,y,z} * frequency_response** (see Frequency Response Chart). This linearization is implemented in DASY4 software versions later than 4.2. The uncertainty of the frequency response is included in the stated uncertainty of ConvF.
- **DCP_{x,y,z}**: DCP are numerical linearization parameters assessed based on the data of power sweep with CW signal (no uncertainty required). DCP does not depend on frequency nor media.
- **PAR**: PAR is the Peak to Average Ratio that is not calibrated but determined based on the signal characteristics
- **A_{x,y,z}; B_{x,y,z}; C_{x,y,z}; D_{x,y,z}; VR_{x,y,z}**: A, B, C, D are numerical linearization parameters assessed based on the data of power sweep for specific modulation signal. The parameters do not depend on frequency nor media. VR is the maximum calibration range expressed in RMS voltage across the diode.
- **ConvF and Boundary Effect Parameters**: Assessed in flat phantom using E-field (or Temperature Transfer Standard for $f \leq 800$ MHz) and inside waveguide using analytical field distributions based on power measurements for $f > 800$ MHz. The same setups are used for assessment of the parameters applied for boundary compensation (alpha, depth) of which typical uncertainty values are given. These parameters are used in DASY4 software to improve probe accuracy close to the boundary. The sensitivity in TSL corresponds to NORM_{x,y,z} * ConvF whereby the uncertainty corresponds to that given for ConvF. A frequency dependent ConvF is used in DASY version 4.4 and higher which allows extending the validity from ± 50 MHz to ± 100 MHz.
- **Spherical Isotropy (3D deviation from isotropy)**: in a field of low gradients realized using a flat phantom exposed by a patch antenna.
- **Sensor Offset**: The sensor offset corresponds to the offset of virtual measurement center from the probe tip (on probe axis). No tolerance required.
- **Connector Angle**: The angle is assessed using the information gained by determining the NORM_x (no uncertainty required).

Probe ES3DV3

SN:3334

Manufactured: January 24, 2012
Repaired: December 9, 2014
Calibrated: December 16, 2014

Calibrated for DASY/EASY Systems
(Note: non-compatible with DASY2 system!)

DASY/EASY - Parameters of Probe: ES3DV3 - SN:3334

Basic Calibration Parameters

	Sensor X	Sensor Y	Sensor Z	Unc (k=2)
Norm ($\mu\text{V}/(\text{V}/\text{m})^2$) ^A	1.04	1.05	1.01	$\pm 10.1 \%$
DCP (mV) ^B	106.5	105.0	105.6	

Modulation Calibration Parameters

UID	Communication System Name		A dB	B dB $\sqrt{\mu\text{V}}$	C	D dB	VR mV	Unc ^F (k=2)
0	CW	X	0.0	0.0	1.0	0.00	188.0	$\pm 3.0 \%$
		Y	0.0	0.0	1.0		183.2	
		Z	0.0	0.0	1.0		181.8	
10010-CAA	SAR Validation (Square, 100ms, 10ms)	X	4.61	67.2	13.7	10.00	38.4	$\pm 1.4 \%$
		Y	20.36	82.7	18.7		38.0	
		Z	17.55	80.3	17.6		37.0	
10011-CAB	UMTS-FDD (WCDMA)	X	3.56	68.4	19.1	2.91	148.4	$\pm 0.7 \%$
		Y	3.44	68.1	19.2		146.9	
		Z	3.52	68.3	19.1		144.7	
10012-CAB	IEEE 802.11b WIFI 2.4 GHz (DSSS, 1 Mbps)	X	3.54	71.9	20.0	1.87	148.0	$\pm 0.7 \%$
		Y	3.51	72.2	20.5		148.9	
		Z	3.80	73.3	20.6		144.6	
10013-CAB	IEEE 802.11g WIFI 2.4 GHz (DSSS-OFDM, 6 Mbps)	X	11.39	71.1	23.3	9.46	149.8	$\pm 3.8 \%$
		Y	11.54	71.8	24.0		149.5	
		Z	11.11	70.5	23.0		141.6	
10021-DAB	GSM-FDD (TDMA, GMSK)	X	15.29	91.3	25.0	9.39	131.9	$\pm 1.7 \%$
		Y	24.16	100.0	28.4		142.8	
		Z	13.05	89.2	24.5		126.5	
10023-DAB	GPRS-FDD (TDMA, GMSK, TN 0)	X	16.07	91.7	25.1	9.57	144.0	$\pm 2.2 \%$
		Y	19.00	95.3	26.8		136.4	
		Z	13.93	89.8	24.6		141.0	
10024-DAB	GPRS-FDD (TDMA, GMSK, TN 0-1)	X	19.98	91.0	22.4	6.56	134.2	$\pm 1.9 \%$
		Y	34.78	99.7	25.5		145.0	
		Z	29.89	96.8	24.1		129.8	
10027-DAB	GPRS-FDD (TDMA, GMSK, TN 0-1-2)	X	56.30	99.7	22.8	4.80	125.2	$\pm 1.9 \%$
		Y	41.16	99.6	23.9		131.2	
		Z	50.78	99.8	23.1		147.6	
10028-DAB	GPRS-FDD (TDMA, GMSK, TN 0-1-2-3)	X	49.35	99.7	22.5	3.55	133.2	$\pm 2.2 \%$
		Y	46.49	99.6	22.9		139.2	
		Z	58.21	99.7	22.0		129.4	
10032-CAA	IEEE 802.15.1 Bluetooth (GFSK, DH5)	X	56.54	100.0	20.2	1.16	128.0	$\pm 1.7 \%$
		Y	20.03	99.3	22.4		130.3	
		Z	84.01	100.0	19.4		141.0	
10100-CAB	LTE-FDD (SC-FDMA, 100% RB, 20 MHz, QPSK)	X	6.44	67.6	19.6	5.67	138.5	$\pm 1.4 \%$
		Y	6.50	67.9	20.0		142.1	
		Z	6.31	67.2	19.4		129.4	

10103-CAB	LTE-TDD (SC-FDMA, 100% RB, 20 MHz, QPSK)	X	9.77	73.6	24.6	9.29	129.6	±3.3 %
		Y	10.52	76.0	26.3		132.1	
		Z	10.21	75.0	25.4		147.7	
10108-CAC	LTE-FDD (SC-FDMA, 100% RB, 10 MHz, QPSK)	X	6.36	67.2	19.6	5.80	136.8	±1.4 %
		Y	6.31	67.3	19.8		137.2	
		Z	6.20	66.7	19.3		128.8	
10117-CAB	IEEE 802.11n (HT Mixed, 13.5 Mbps, BPSK)	X	9.96	68.3	20.8	8.07	126.5	±2.5 %
		Y	10.12	68.8	21.3		126.6	
		Z	10.22	69.0	21.2		143.7	
10151-CAB	LTE-TDD (SC-FDMA, 50% RB, 20 MHz, QPSK)	X	9.29	73.0	24.4	9.28	125.3	±3.3 %
		Y	9.65	74.5	25.6		124.4	
		Z	9.65	74.3	25.2		141.1	
10154-CAC	LTE-FDD (SC-FDMA, 50% RB, 10 MHz, QPSK)	X	6.03	66.7	19.3	5.75	132.7	±1.4 %
		Y	5.97	66.7	19.5		132.7	
		Z	6.17	67.3	19.7		148.3	
10160-CAB	LTE-FDD (SC-FDMA, 50% RB, 15 MHz, QPSK)	X	6.47	67.2	19.5	5.82	138.1	±1.4 %
		Y	6.44	67.3	19.8		138.2	
		Z	6.27	66.6	19.2		126.8	
10169-CAB	LTE-FDD (SC-FDMA, 1 RB, 20 MHz, QPSK)	X	5.03	66.9	19.6	5.73	137.2	±1.2 %
		Y	4.97	67.0	19.9		135.7	
		Z	4.91	66.5	19.5		127.1	
10172-CAB	LTE-TDD (SC-FDMA, 1 RB, 20 MHz, QPSK)	X	8.53	77.4	26.9	9.21	142.4	±2.7 %
		Y	9.59	81.3	29.3		142.3	
		Z	7.78	75.0	25.7		126.7	
10175-CAC	LTE-FDD (SC-FDMA, 1 RB, 10 MHz, QPSK)	X	5.02	67.0	19.7	5.72	131.8	±1.2 %
		Y	4.98	67.0	19.9		136.1	
		Z	4.95	66.8	19.6		128.1	
10181-CAB	LTE-FDD (SC-FDMA, 1 RB, 15 MHz, QPSK)	X	4.99	66.8	19.6	5.72	131.2	±1.2 %
		Y	4.99	67.1	20.0		136.2	
		Z	4.92	66.6	19.5		127.9	
10196-CAB	IEEE 802.11n (HT Mixed, 6.5 Mbps, BPSK)	X	9.98	68.8	21.2	8.10	141.7	±2.5 %
		Y	10.14	69.5	21.8		147.2	
		Z	9.85	68.6	21.1		137.5	
10225-CAB	UMTS-FDD (HSPA+)	X	7.17	67.5	19.6	5.97	146.0	±1.4 %
		Y	7.13	67.7	19.9		149.9	
		Z	7.12	67.5	19.6		142.9	
10237-CAB	LTE-TDD (SC-FDMA, 1 RB, 10 MHz, QPSK)	X	8.29	76.6	26.5	9.21	136.1	±2.7 %
		Y	9.60	81.4	29.3		142.3	
		Z	7.98	75.8	26.1		132.9	
10252-CAB	LTE-TDD (SC-FDMA, 50% RB, 10 MHz, QPSK)	X	9.27	74.1	25.1	9.24	139.1	±3.3 %
		Y	10.25	77.5	27.4		146.3	
		Z	9.07	73.7	25.0		135.8	
10267-CAB	LTE-TDD (SC-FDMA, 100% RB, 10 MHz, QPSK)	X	9.95	74.9	25.4	9.30	147.0	±3.3 %
		Y	9.80	75.0	25.9		125.9	
		Z	9.74	74.6	25.4		143.8	

10275-CAB	UMTS-FDD (HSUPA, Sublest 5, 3GPP Rel8.4)	X	4.63	67.6	19.0	3.96	147.5	±0.7 %
		Y	4.41	66.9	18.9		129.5	
		Z	4.61	67.6	19.1		148.1	
10291-AAB	CDMA2000, RC3, SO55, Full Rate	X	3.83	67.7	19.0	3.46	133.7	±0.7 %
		Y	3.71	67.4	19.0		139.0	
		Z	3.86	68.1	19.2		133.7	
10292-AAB	CDMA2000, RC3, SO32, Full Rate	X	3.85	68.2	19.2	3.39	136.7	±0.5 %
		Y	3.67	67.5	19.1		141.3	
		Z	3.75	67.8	19.0		136.2	
10297-AAA	LTE-FDD (SC-FDMA, 50% RB, 20 MHz, QPSK)	X	6.31	67.1	19.5	5.81	130.6	±1.4 %
		Y	6.32	67.3	19.8		135.1	
		Z	6.24	66.9	19.4		129.2	
10311-AAA	LTE-FDD (SC-FDMA, 100% RB, 15 MHz, QPSK)	X	6.85	67.5	19.8	6.06	135.1	±1.4 %
		Y	6.90	67.9	20.2		141.5	
		Z	6.82	67.5	19.8		135.1	
10403-AAB	CDMA2000 (1xEV-DO, Rev. 0)	X	5.04	69.1	19.1	3.76	126.0	±0.5 %
		Y	4.90	69.0	19.3		129.6	
		Z	5.11	69.7	19.4		125.8	
10404-AAB	CDMA2000 (1xEV-DO, Rev. A)	X	5.05	69.6	19.4	3.77	147.1	±0.7 %
		Y	4.84	69.2	19.5		127.8	
		Z	5.15	70.1	19.6		143.3	
10415-AAA	IEEE 802.11b WIFI 2.4 GHz (DSSS, 1 Mbps, 99pc duty cycle)	X	3.13	71.2	19.9	1.54	144.5	±0.5 %
		Y	2.93	70.4	19.9		149.8	
		Z	3.18	71.6	20.1		141.4	
10416-AAA	IEEE 802.11g WIFI 2.4 GHz (ERP-OFDM, 6 Mbps, 99pc duty cycle)	X	10.11	69.0	21.4	8.23	144.3	±2.5 %
		Y	10.21	69.6	21.9		148.3	
		Z	9.99	68.9	21.3		141.1	

The reported uncertainty of measurement is stated as the standard uncertainty of measurement multiplied by the coverage factor $k=2$, which for a normal distribution corresponds to a coverage probability of approximately 95%.

^A The uncertainties of NormX,Y,Z do not affect the E^2 -field uncertainty inside TSL. (see Pages 7 and 8).

^B Numerical linearization parameter: uncertainty not required.

^E Uncertainty is determined using the max. deviation from linear response applying rectangular distribution and is expressed for the square of the field value.

DASY/EASY - Parameters of Probe: ES3DV3 - SN:3334

Calibration Parameter Determined in Head Tissue Simulating Media

f (MHz) ^c	Relative Permittivity ^f	Conductivity (S/m) ^f	ConvF X	ConvF Y	ConvF Z	Alpha ^g	Depth ^g (mm)	Unct. (k=2)
750	41.9	0.89	6.51	6.51	6.51	0.80	1.17	± 12.0 %
835	41.5	0.90	6.25	6.25	6.25	0.38	1.58	± 12.0 %
1750	40.1	1.37	5.21	5.21	5.21	0.43	1.63	± 12.0 %
1900	40.0	1.40	5.03	5.03	5.03	0.53	1.45	± 12.0 %
2450	39.2	1.80	4.51	4.51	4.51	0.80	1.26	± 12.0 %
2600	39.0	1.96	4.31	4.31	4.31	0.79	1.27	± 12.0 %

^c Frequency validity above 300 MHz of ± 100 MHz only applies for DASY v4.4 and higher (see Page 2), else it is restricted to ± 50 MHz. The uncertainty is the RSS of the ConvF uncertainty at calibration frequency and the uncertainty for the indicated frequency band. Frequency validity below 300 MHz is ± 10, 25, 40, 50 and 70 MHz for ConvF assessments at 30, 64, 128, 150 and 220 MHz respectively. Above 5 GHz frequency validity can be extended to ± 110 MHz.

^f At frequencies below 3 GHz, the validity of tissue parameters (ϵ and σ) can be relaxed to ± 10% if liquid compensation formula is applied to measured SAR values. At frequencies above 3 GHz, the validity of tissue parameters (ϵ and σ) is restricted to ± 5%. The uncertainty is the RSS of the ConvF uncertainty for indicated target tissue parameters.

^g Alpha/Depth are determined during calibration. SPEAG warrants that the remaining deviation due to the boundary effect after compensation is always less than ± 1% for frequencies below 3 GHz and below ± 2% for frequencies between 3-6 GHz at any distance larger than half the probe tip diameter from the boundary.

DASY/EASY - Parameters of Probe: ES3DV3 - SN:3334

Calibration Parameter Determined in Body Tissue Simulating Media

f (MHz) ^c	Relative Permittivity ^f	Conductivity (S/m) ^f	ConvF X	ConvF Y	ConvF Z	Alpha ^g	Depth ^d (mm)	Unct. (k=2)
750	55.5	0.96	6.09	6.09	6.09	0.49	1.47	± 12.0 %
835	55.2	0.97	6.14	6.14	6.14	0.69	1.27	± 12.0 %
1750	53.4	1.49	4.94	4.94	4.94	0.80	1.24	± 12.0 %
1900	53.3	1.52	4.73	4.73	4.73	0.62	1.44	± 12.0 %
2450	52.7	1.95	4.28	4.28	4.28	0.80	1.13	± 12.0 %
2600	52.5	2.16	4.16	4.16	4.16	0.75	1.25	± 12.0 %

^c Frequency validity above 300 MHz of ± 100 MHz only applies for DASY v4.4 and higher (see Page 2), else it is restricted to ± 50 MHz. The uncertainty is the RSS of the ConvF uncertainty at calibration frequency and the uncertainty for the indicated frequency band. Frequency validity below 300 MHz is ± 10, 25, 40, 50 and 70 MHz for ConvF assessments at 30, 64, 128, 150 and 220 MHz respectively. Above 5 GHz frequency validity can be extended to ± 110 MHz.

^f At frequencies below 3 GHz, the validity of tissue parameters (ϵ and σ) can be relaxed to ± 10% if liquid compensation formula is applied to measured SAR values. At frequencies above 3 GHz, the validity of tissue parameters (ϵ and σ) is restricted to ± 5%. The uncertainty is the RSS of the ConvF uncertainty for indicated target tissue parameters.

^g Alpha/Depth are determined during calibration. SPEAG warrants that the remaining deviation due to the boundary effect after compensation is always less than ± 1% for frequencies below 3 GHz and below ± 2% for frequencies between 3-6 GHz at any distance larger than half the probe tip diameter from the boundary.

Frequency Response of E-Field (TEM-Cell:ifi110 EXX, Waveguide: R22)

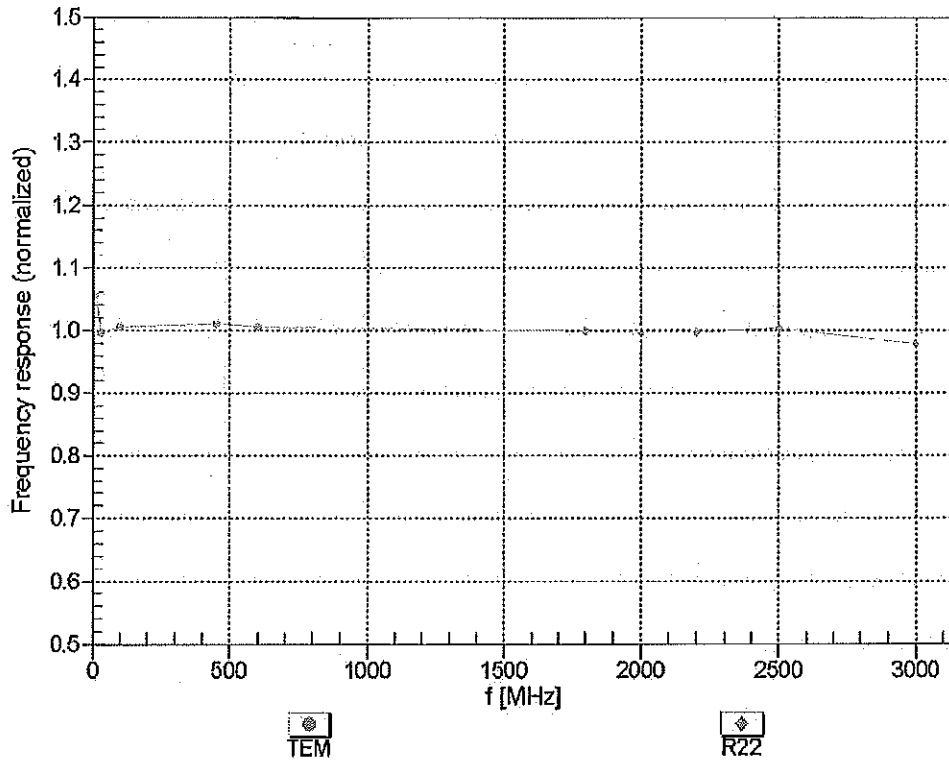

Uncertainty of Frequency Response of E-field: $\pm 6.3\%$ ($k=2$)

Receiving Pattern (ϕ), $\theta = 0^\circ$

f=600 MHz,TEM

f=1800 MHz,R22

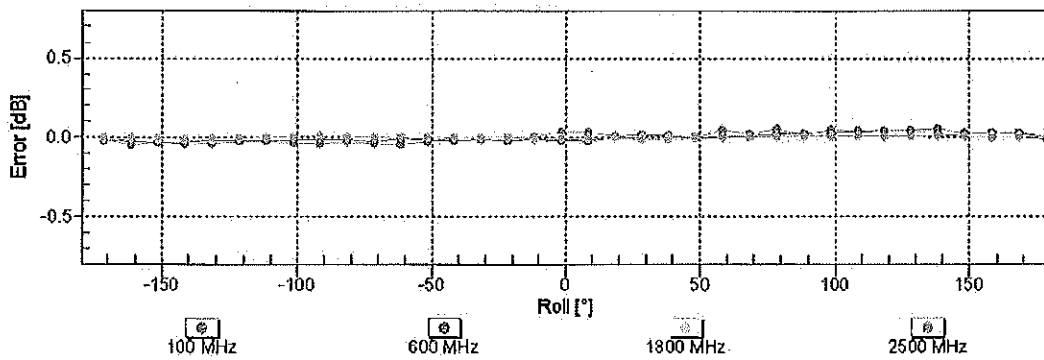
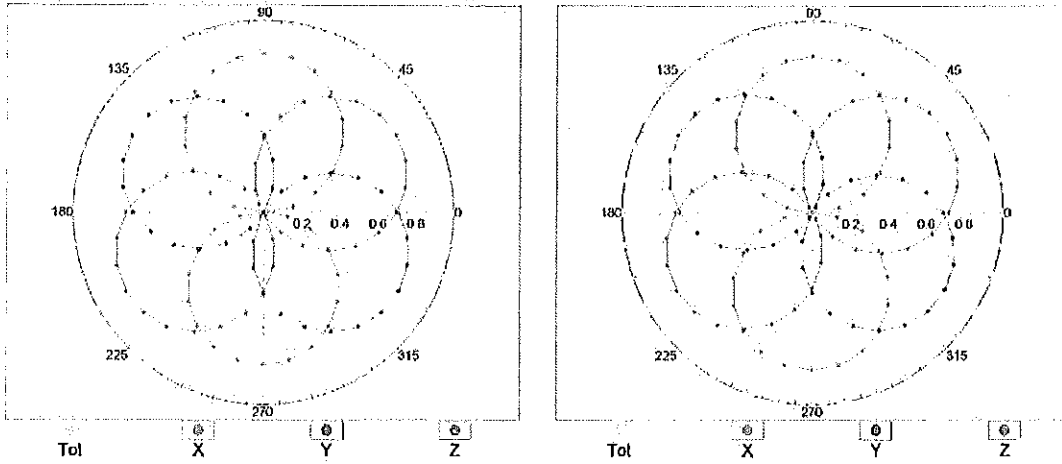

Uncertainty of Axial Isotropy Assessment: $\pm 0.5\%$ ($k=2$)

Dynamic Range f(SAR_{head}) (TEM cell , f_{eval}= 1900 MHz)

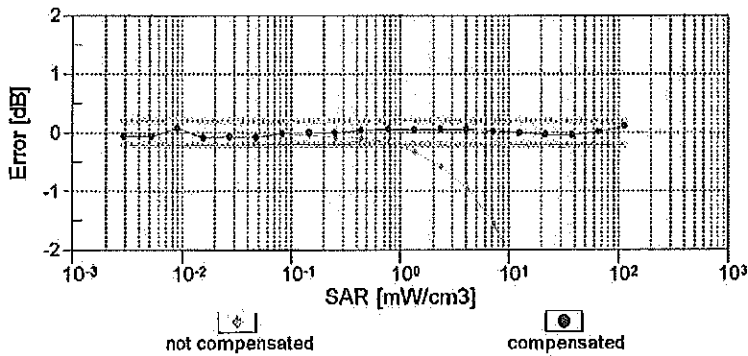
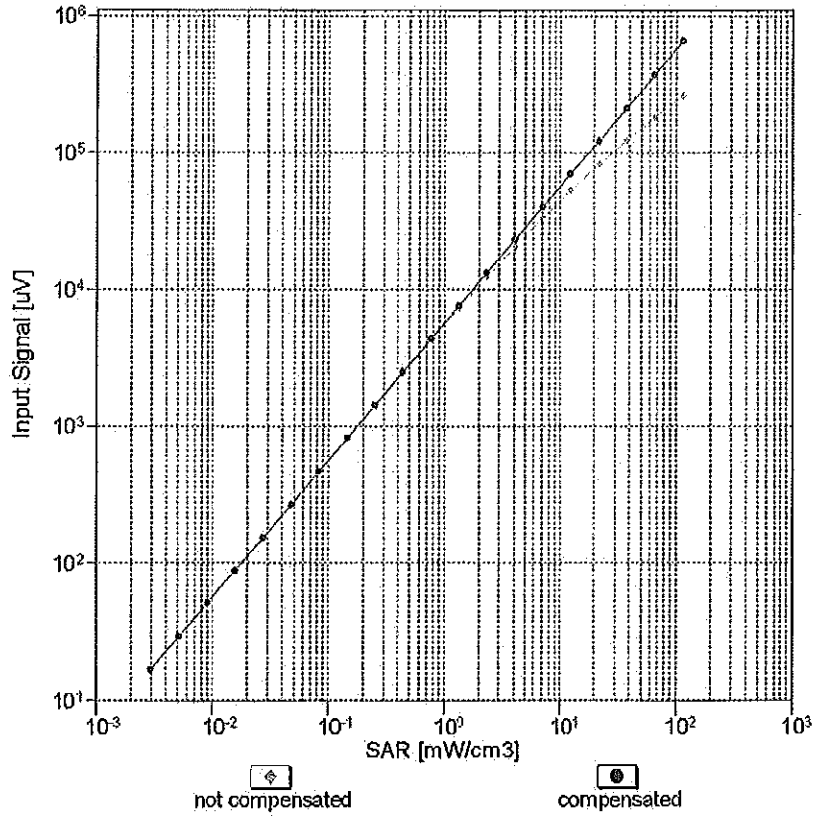

Uncertainty of Linearity Assessment: ± 0.6% (k=2)

Conversion Factor Assessment

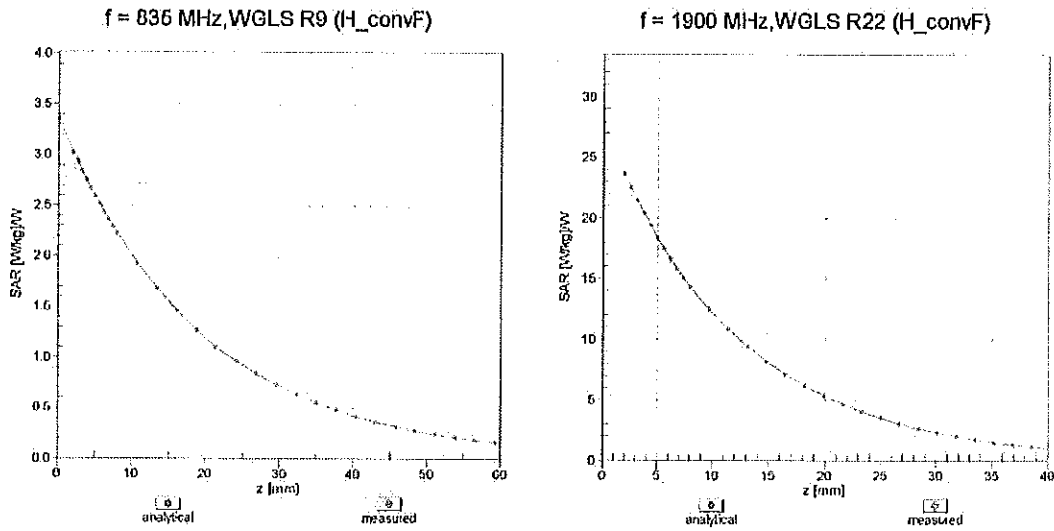

Deviation from Isotropy in Liquid Error (ϕ, θ), f = 900 MHz

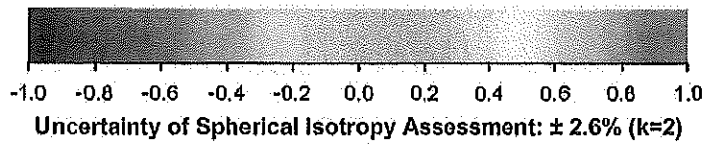
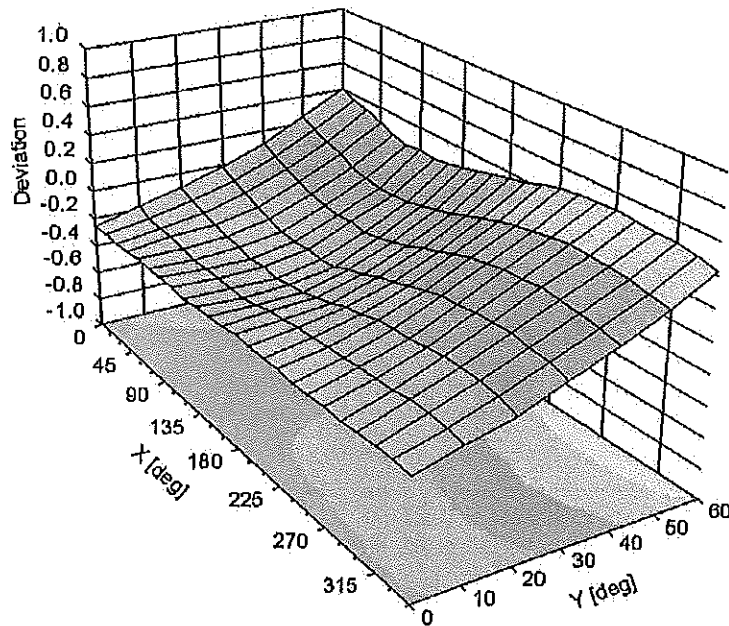

Uncertainty of Spherical Isotropy Assessment: $\pm 2.6\%$ (k=2)

DASY/EASY - Parameters of Probe: ES3DV3 - SN:3334**Other Probe Parameters**

Sensor Arrangement	Triangular
Connector Angle (°)	18.5
Mechanical Surface Detection Mode	enabled
Optical Surface Detection Mode	disabled
Probe Overall Length	337 mm
Probe Body Diameter	10 mm
Tip Length	10 mm
Tip Diameter	4 mm
Probe Tip to Sensor X Calibration Point	2 mm
Probe Tip to Sensor Y Calibration Point	2 mm
Probe Tip to Sensor Z Calibration Point	2 mm
Recommended Measurement Distance from Surface	3 mm



Accredited by the Swiss Accreditation Service (SAS)
The Swiss Accreditation Service is one of the signatories to the EA
Multilateral Agreement for the recognition of calibration certificates

Accreditation No.: **SCS 0108**

Client **PC Test**

Certificate No: **EX3-3914_Feb15**

CALIBRATION CERTIFICATE

Object **EX3DV4 - SN:3914** CCV
3/6/15

Calibration procedure(s) **QA CAL-01.v9, QA CAL-14.v4, QA CAL-23.v5, QA CAL-25.v6
Calibration procedure for dosimetric E-field probes**

Calibration date: **February 10, 2015**

This calibration certificate documents the traceability to national standards, which realize the physical units of measurements (SI).
The measurements and the uncertainties with confidence probability are given on the following pages and are part of the certificate.

All calibrations have been conducted in the closed laboratory facility: environment temperature (22 ± 3)°C and humidity < 70%.

Calibration Equipment used (M&TE critical for calibration)

Primary Standards	ID	Cal Date (Certificate No.)	Scheduled Calibration
Power meter E4419B	GB41293874	03-Apr-14 (No. 217-01911)	Apr-15
Power sensor E4412A	MY41498087	03-Apr-14 (No. 217-01911)	Apr-15
Reference 3 dB Attenuator	SN: S5054 (3c)	03-Apr-14 (No. 217-01915)	Apr-15
Reference 20 dB Attenuator	SN: S5277 (20x)	03-Apr-14 (No. 217-01919)	Apr-15
Reference 30 dB Attenuator	SN: S5129 (30b)	03-Apr-14 (No. 217-01920)	Apr-15
Reference Probe ES3DV2	SN: 3013	30-Dec-14 (No. ES3-3013_Dec14)	Dec-15
DAE4	SN: 660	14-Jan-15 (No. DAE4-660_Jan15)	Jan-16
Secondary Standards	ID	Check Date (in house)	Scheduled Check
RF generator HP 8648C	US3642U01700	4-Aug-99 (in house check Apr-13)	In house check: Apr-16
Network Analyzer HP 8753E	US37390585	18-Oct-01 (in house check Oct-14)	In house check: Oct-15

Calibrated by:	Name Claudio Leubler	Function Laboratory Technician	Signature
Approved by:	Name Katja Pokovic	Function Technical Manager	

Issued: February 10, 2015

This calibration certificate shall not be reproduced except in full without written approval of the laboratory.



Accredited by the Swiss Accreditation Service (SAS)

Accreditation No.: **SCS 0108**

The Swiss Accreditation Service is one of the signatories to the EA Multilateral Agreement for the recognition of calibration certificates

Glossary:

TSL	tissue simulating liquid
NORM _{x,y,z}	sensitivity in free space
ConvF	sensitivity in TSL / NORM _{x,y,z}
DCP	diode compression point
CF	crest factor (1/duty_cycle) of the RF signal
A, B, C, D	modulation dependent linearization parameters
Polarization φ	φ rotation around probe axis
Polarization ϑ	ϑ rotation around an axis that is in the plane normal to probe axis (at measurement center), i.e., $\vartheta = 0$ is normal to probe axis
Connector Angle	information used in DASY system to align probe sensor X to the robot coordinate system

Calibration is Performed According to the Following Standards:

- a) IEEE Std 1528-2013, "IEEE Recommended Practice for Determining the Peak Spatial-Averaged Specific Absorption Rate (SAR) in the Human Head from Wireless Communications Devices: Measurement Techniques", June 2013
- b) IEC 62209-1, "Procedure to measure the Specific Absorption Rate (SAR) for hand-held devices used in close proximity to the ear (frequency range of 300 MHz to 3 GHz)", February 2005

Methods Applied and Interpretation of Parameters:

- *NORM_{x,y,z}*: Assessed for E-field polarization $\vartheta = 0$ ($f \leq 900$ MHz in TEM-cell; $f > 1800$ MHz: R22 waveguide). *NORM_{x,y,z}* are only intermediate values, i.e., the uncertainties of *NORM_{x,y,z}* does not affect the E^2 -field uncertainty inside TSL (see below *ConvF*).
- *NORM(f)_{x,y,z}* = *NORM_{x,y,z}* * *frequency_response* (see Frequency Response Chart). This linearization is implemented in DASY4 software versions later than 4.2. The uncertainty of the frequency response is included in the stated uncertainty of *ConvF*.
- *DCP_{x,y,z}*: DCP are numerical linearization parameters assessed based on the data of power sweep with CW signal (no uncertainty required). DCP does not depend on frequency nor media.
- *PAR*: PAR is the Peak to Average Ratio that is not calibrated but determined based on the signal characteristics
- *A_{x,y,z}; B_{x,y,z}; C_{x,y,z}; D_{x,y,z}; VR_{x,y,z}; A, B, C, D* are numerical linearization parameters assessed based on the data of power sweep for specific modulation signal. The parameters do not depend on frequency nor media. *VR* is the maximum calibration range expressed in RMS voltage across the diode.
- *ConvF and Boundary Effect Parameters*: Assessed in flat phantom using E-field (or Temperature Transfer Standard for $f \leq 800$ MHz) and inside waveguide using analytical field distributions based on power measurements for $f > 800$ MHz. The same setups are used for assessment of the parameters applied for boundary compensation (alpha, depth) of which typical uncertainty values are given. These parameters are used in DASY4 software to improve probe accuracy close to the boundary. The sensitivity in TSL corresponds to *NORM_{x,y,z}* * *ConvF* whereby the uncertainty corresponds to that given for *ConvF*. A frequency dependent *ConvF* is used in DASY version 4.4 and higher which allows extending the validity from ± 50 MHz to ± 100 MHz.
- *Spherical isotropy (3D deviation from isotropy)*: in a field of low gradients realized using a flat phantom exposed by a patch antenna.
- *Sensor Offset*: The sensor offset corresponds to the offset of virtual measurement center from the probe tip (on probe axis). No tolerance required.
- *Connector Angle*: The angle is assessed using the information gained by determining the *NORM_x* (no uncertainty required).

Probe EX3DV4

SN:3914

Manufactured:	December 18, 2012
Repaired:	January 23, 2015
Calibrated:	February 10, 2015

Calibrated for DASY/EASY Systems
(Note: non-compatible with DASY2 system!)

DASY/EASY - Parameters of Probe: EX3DV4 - SN:3914

Basic Calibration Parameters

	Sensor X	Sensor Y	Sensor Z	Unc (k=2)
Norm ($\mu\text{V}/(\text{V}/\text{m})^2$) ^A	0.48	0.42	0.45	$\pm 10.1\%$
DCP (mV) ^B	102.7	103.2	101.3	

Modulation Calibration Parameters

UID	Communication System Name		A dB	B dB $\sqrt{\mu\text{V}}$	C	D dB	VR mV	Unc ^E (k=2)
0	CW	X	0.0	0.0	1.0	0.00	137.3	$\pm 2.7\%$
		Y	0.0	0.0	1.0		140.8	
		Z	0.0	0.0	1.0		134.6	
10010- CAA	SAR Validation (Square, 100ms, 10ms)	X	1.33	60.3	9.9	10.00	40.4	$\pm 1.2\%$
		Y	1.02	57.7	9.2		42.2	
		Z	1.41	61.3	11.0		39.9	
10011- CAB	UMTS-FDD (WCDMA)	X	3.39	67.3	18.6	2.91	148.9	$\pm 0.5\%$
		Y	3.47	67.6	18.6		130.1	
		Z	3.30	66.5	17.9		145.8	
10012- CAB	IEEE 802.11b WiFi 2.4 GHz (DSSS, 1 Mbps)	X	2.92	68.9	18.9	1.87	149.0	$\pm 0.7\%$
		Y	3.17	70.1	19.2		131.4	
		Z	2.72	67.0	17.6		146.9	
10013- CAB	IEEE 802.11g WiFi 2.4 GHz (DSSS-OFDM, 6 Mbps)	X	10.52	69.1	22.1	9.46	140.7	$\pm 3.3\%$
		Y	10.67	69.8	22.6		146.8	
		Z	10.44	68.9	22.0		136.8	
10021- DAB	GSM-FDD (TDMA, GMSK)	X	1.64	63.4	11.8	9.39	86.2	$\pm 1.7\%$
		Y	2.03	65.7	13.6		105.2	
		Z	1.78	63.6	12.4		85.9	
10023- DAB	GPRS-FDD (TDMA, GMSK, TN 0)	X	1.78	65.0	13.2	9.57	84.0	$\pm 2.2\%$
		Y	1.84	63.8	12.5		101.1	
		Z	1.92	64.9	13.4		83.0	
10024- DAB	GPRS-FDD (TDMA, GMSK, TN 0-1)	X	2.04	68.8	13.2	6.56	141.3	$\pm 1.9\%$
		Y	2.32	70.4	14.4		134.7	
		Z	1.59	65.5	12.3		139.3	
10027- DAB	GPRS-FDD (TDMA, GMSK, TN 0-1-2)	X	1.51	67.3	11.9	4.80	148.8	$\pm 1.9\%$
		Y	1.27	63.7	10.0		136.2	
		Z	3.26	75.5	15.4		148.7	
10028- DAB	GPRS-FDD (TDMA, GMSK, TN 0-1-2-3)	X	52.54	99.9	20.2	3.55	143.3	$\pm 1.7\%$
		Y	2.95	74.0	13.7		149.7	
		Z	32.98	99.9	21.5		141.9	
10032- CAA	IEEE 802.15.1 Bluetooth (GFSK, DH5)	X	96.97	99.5	17.5	1.16	145.3	$\pm 1.2\%$
		Y	83.69	99.7	18.1		128.6	
		Z	0.69	65.4	9.0		143.2	

10062-CAB	IEEE 802.11a/h WiFi 5 GHz (OFDM, 6 Mbps)	X	10.27	68.9	21.5	8.68	145.1	±2.7 %
		Y	9.95	68.4	21.3		123.8	
		Z	10.18	68.8	21.4		140.9	
10100-CAB	LTE-FDD (SC-FDMA, 100% RB, 20 MHz, QPSK)	X	6.38	67.0	19.3	5.67	140.1	±1.4 %
		Y	6.54	67.7	19.6		147.0	
		Z	6.34	66.8	19.1		137.4	
10103-CAB	LTE-TDD (SC-FDMA, 100% RB, 20 MHz, QPSK)	X	7.44	67.6	21.6	9.29	132.4	±1.7 %
		Y	7.78	69.0	22.4		140.2	
		Z	7.40	67.4	21.4		129.5	
10108-CAC	LTE-FDD (SC-FDMA, 100% RB, 10 MHz, QPSK)	X	6.25	66.7	19.2	5.80	137.9	±1.4 %
		Y	6.36	67.2	19.5		143.3	
		Z	6.20	66.4	19.0		135.0	
10117-CAB	IEEE 802.11n (HT Mixed, 13.5 Mbps, BPSK)	X	10.03	68.2	20.7	8.07	128.5	±2.5 %
		Y	10.17	68.7	21.0		134.9	
		Z	9.94	68.0	20.5		125.2	
10151-CAB	LTE-TDD (SC-FDMA, 50% RB, 20 MHz, QPSK)	X	7.21	67.6	21.8	9.28	149.5	±1.9 %
		Y	7.39	68.5	22.3		135.1	
		Z	7.19	67.5	21.7		147.3	
10154-CAC	LTE-FDD (SC-FDMA, 50% RB, 10 MHz, QPSK)	X	5.91	66.2	19.1	5.75	133.8	±1.2 %
		Y	6.04	66.8	19.4		139.4	
		Z	5.88	66.0	18.9		131.1	
10160-CAB	LTE-FDD (SC-FDMA, 50% RB, 15 MHz, QPSK)	X	6.36	66.7	19.3	5.82	139.0	±1.4 %
		Y	6.51	67.4	19.7		145.5	
		Z	6.31	66.4	19.0		136.5	
10169-CAB	LTE-FDD (SC-FDMA, 1 RB, 20 MHz, QPSK)	X	4.79	66.3	19.4	5.73	136.1	±1.2 %
		Y	4.90	67.0	19.8		141.5	
		Z	4.76	66.0	19.1		133.8	
10172-CAB	LTE-TDD (SC-FDMA, 1 RB, 20 MHz, QPSK)	X	5.66	68.8	22.7	9.21	138.2	±2.5 %
		Y	5.93	70.3	23.7		147.0	
		Z	5.68	68.6	22.6		136.7	
10175-CAC	LTE-FDD (SC-FDMA, 1 RB, 10 MHz, QPSK)	X	4.77	66.2	19.3	5.72	135.7	±1.2 %
		Y	4.92	67.1	19.8		141.2	
		Z	4.72	65.8	19.0		133.6	
10181-CAB	LTE-FDD (SC-FDMA, 1 RB, 15 MHz, QPSK)	X	4.77	66.2	19.3	5.72	134.8	±1.2 %
		Y	4.91	67.0	19.7		141.1	
		Z	4.76	66.0	19.1		132.8	
10196-CAB	IEEE 802.11n (HT Mixed, 6.5 Mbps, BPSK)	X	9.99	68.8	21.1	8.10	146.9	±2.5 %
		Y	9.71	68.4	21.0		127.0	
		Z	9.91	68.7	21.0		143.4	
10225-CAB	UMTS-FDD (HSPA+)	X	7.10	67.5	19.5	5.97	149.1	±1.2 %
		Y	6.98	67.4	19.5		128.9	
		Z	7.01	67.2	19.3		145.5	

10237-CAB	LTE-TDD (SC-FDMA, 1 RB, 10 MHz, QPSK)	X	5.68	68.9	22.8	9.21	139.9	±2.2 %
		Y	5.93	70.3	23.6		148.1	
		Z	5.70	68.8	22.7		137.5	
10252-CAB	LTE-TDD (SC-FDMA, 50% RB, 10 MHz, QPSK)	X	6.81	67.4	21.7	9.24	143.4	±2.2 %
		Y	6.93	68.0	22.2		129.3	
		Z	6.79	67.2	21.6		140.3	
10267-CAB	LTE-TDD (SC-FDMA, 100% RB, 10 MHz, QPSK)	X	7.23	67.7	21.9	9.30	149.4	±1.9 %
		Y	7.42	68.6	22.4		135.2	
		Z	7.19	67.4	21.6		146.2	
10275-CAB	UMTS-FDD (HSUPA, Subtest 5, 3GPP Rel8.4)	X	4.44	66.7	18.6	3.96	129.1	±0.7 %
		Y	4.57	67.4	18.9		134.5	
		Z	4.35	66.1	18.1		126.6	
10291-AAB	CDMA2000, RC3, SO55, Full Rate	X	3.64	66.9	18.6	3.46	140.9	±0.7 %
		Y	3.87	68.3	19.3		147.1	
		Z	3.61	66.5	18.2		138.4	
10292-AAB	CDMA2000, RC3, SO32, Full Rate	X	3.64	67.4	18.8	3.39	142.3	±0.5 %
		Y	3.85	68.5	19.3		148.3	
		Z	3.59	66.7	18.3		139.6	
10297-AAA	LTE-FDD (SC-FDMA, 50% RB, 20 MHz, QPSK)	X	6.23	66.6	19.2	5.81	136.3	±1.4 %
		Y	6.42	67.4	19.7		142.8	
		Z	6.19	66.3	19.0		133.9	
10311-AAA	LTE-FDD (SC-FDMA, 100% RB, 15 MHz, QPSK)	X	6.84	67.3	19.6	6.06	142.4	±1.4 %
		Y	6.98	67.8	19.9		149.5	
		Z	6.75	66.8	19.3		140.0	
10317-AAB	IEEE 802.11a WiFi 5 GHz (OFDM, 6 Mbps, 96pc duty cycle)	X	10.13	68.9	21.3	8.36	147.4	±2.7 %
		Y	9.84	68.4	21.1		127.5	
		Z	10.04	68.7	21.2		143.2	
10400-AAB	IEEE 802.11ac WiFi (20MHz, 64-QAM, 99pc duty cycle)	X	10.24	69.0	21.4	8.37	148.6	±2.7 %
		Y	9.92	68.4	21.2		126.6	
		Z	10.14	68.8	21.3		144.6	
10401-AAB	IEEE 802.11ac WiFi (40MHz, 64-QAM, 99pc duty cycle)	X	10.60	68.6	21.2	8.60	129.4	±3.0 %
		Y	10.77	69.1	21.5		136.8	
		Z	10.52	68.4	21.1		125.9	
10402-AAB	IEEE 802.11ac WiFi (80MHz, 64-QAM, 99pc duty cycle)	X	10.60	68.5	20.9	8.53	129.7	±3.0 %
		Y	11.01	69.5	21.5		139.1	
		Z	10.54	68.3	20.8		126.7	
10403-AAB	CDMA2000 (1xEV-DO, Rev. 0)	X	5.07	70.1	19.4	3.76	127.5	±0.5 %
		Y	5.47	71.9	20.2		133.6	
		Z	4.93	69.5	19.0		124.9	
10404-AAB	CDMA2000 (1xEV-DO, Rev. A)	X	5.01	70.2	19.5	3.77	149.3	±0.7 %
		Y	5.38	71.9	20.2		132.0	
		Z	4.94	69.9	19.2		146.4	

10415-AAA	IEEE 802.11b WiFi 2.4 GHz (DSSS, 1 Mbps, 99pc duty cycle)	X	3.20	71.2	19.8	1.54	126.8	±0.7 %
		Y	3.51	72.6	20.4		134.5	
		Z	2.79	68.1	18.1		148.4	
10416-AAA	IEEE 802.11g WiFi 2.4 GHz (ERP-OFDM, 6 Mbps, 99pc duty cycle)	X	10.07	68.8	21.2	8.23	147.8	±2.7 %
		Y	9.81	68.4	21.1		128.4	
		Z	10.00	68.7	21.1		144.0	
10417-AAA	IEEE 802.11a/h WiFi 5 GHz (OFDM, 6 Mbps, 99pc duty cycle)	X	10.07	68.8	21.2	8.23	148.4	±2.7 %
		Y	9.82	68.4	21.1		129.0	
		Z	9.99	68.7	21.1		144.6	

The reported uncertainty of measurement is stated as the standard uncertainty of measurement multiplied by the coverage factor $k=2$, which for a normal distribution corresponds to a coverage probability of approximately 95%.

^A The uncertainties of NormX,Y,Z do not affect the E^2 -field uncertainty inside TSL (see Pages 8 and 9).

^B Numerical linearization parameter: uncertainty not required.

^E Uncertainty is determined using the max. deviation from linear response applying rectangular distribution and is expressed for the square of the field value.

DASY/EASY - Parameters of Probe: EX3DV4 - SN:3914

Calibration Parameter Determined in Head Tissue Simulating Media

f (MHz) ^C	Relative Permittivity ^F	Conductivity (S/m) ^F	ConvF X	ConvF Y	ConvF Z	Alpha ^G	Depth ^G (mm)	Unct. (k=2)
750	41.9	0.89	9.82	9.82	9.82	0.39	0.92	± 12.0 %
835	41.5	0.90	9.50	9.50	9.50	0.43	0.83	± 12.0 %
1750	40.1	1.37	8.04	8.04	8.04	0.30	0.93	± 12.0 %
1900	40.0	1.40	7.86	7.86	7.86	0.35	0.86	± 12.0 %
2450	39.2	1.80	7.02	7.02	7.02	0.28	1.05	± 12.0 %
2600	39.0	1.96	6.82	6.82	6.82	0.26	1.17	± 12.0 %
5200	36.0	4.66	5.26	5.26	5.26	0.35	1.80	± 13.1 %
5300	35.9	4.76	5.06	5.06	5.06	0.35	1.80	± 13.1 %
5500	35.6	4.96	4.92	4.92	4.92	0.40	1.80	± 13.1 %
5600	35.5	5.07	4.73	4.73	4.73	0.40	1.80	± 13.1 %
5800	35.3	5.27	4.67	4.67	4.67	0.40	1.80	± 13.1 %

^C Frequency validity above 300 MHz of ± 100 MHz only applies for DASY v4.4 and higher (see Page 2), else it is restricted to ± 50 MHz. The uncertainty is the RSS of the ConvF uncertainty at calibration frequency and the uncertainty for the indicated frequency band. Frequency validity below 300 MHz is ± 10, 25, 40, 50 and 70 MHz for ConvF assessments at 30, 64, 128, 150 and 220 MHz respectively. Above 5 GHz frequency validity can be extended to ± 110 MHz.

^F At frequencies below 3 GHz, the validity of tissue parameters (ϵ and σ) can be relaxed to ± 10% if liquid compensation formula is applied to measured SAR values. At frequencies above 3 GHz, the validity of tissue parameters (ϵ and σ) is restricted to ± 5%. The uncertainty is the RSS of the ConvF uncertainty for indicated target tissue parameters.

^G Alpha/Depth are determined during calibration. SPEAG warrants that the remaining deviation due to the boundary effect after compensation is always less than ± 1% for frequencies below 3 GHz and below ± 2% for frequencies between 3-6 GHz at any distance larger than half the probe tip diameter from the boundary.

DASY/EASY - Parameters of Probe: EX3DV4 - SN:3914

Calibration Parameter Determined in Body Tissue Simulating Media

f (MHz) ^C	Relative Permittivity ^F	Conductivity (S/m) ^F	ConvF X	ConvF Y	ConvF Z	Alpha ^G	Depth (mm) ^G	Unct. (k=2)
750	55.5	0.96	9.53	9.53	9.53	0.33	1.09	± 12.0 %
835	55.2	0.97	9.49	9.49	9.49	0.27	1.25	± 12.0 %
1750	53.4	1.49	7.78	7.78	7.78	0.51	0.79	± 12.0 %
1900	53.3	1.52	7.49	7.49	7.49	0.73	0.64	± 12.0 %
2450	52.7	1.95	7.15	7.15	7.15	0.69	0.64	± 12.0 %
2600	52.5	2.16	6.84	6.84	6.84	0.80	0.57	± 12.0 %
5200	49.0	5.30	4.50	4.50	4.50	0.45	1.90	± 13.1 %
5300	48.9	5.42	4.33	4.33	4.33	0.45	1.90	± 13.1 %
5500	48.6	5.65	3.91	3.91	3.91	0.50	1.90	± 13.1 %
5600	48.5	5.77	3.89	3.89	3.89	0.50	1.90	± 13.1 %
5800	48.2	6.00	4.01	4.01	4.01	0.55	1.90	± 13.1 %

^C Frequency validity above 300 MHz of ± 100 MHz only applies for DASY v4.4 and higher (see Page 2), else it is restricted to ± 50 MHz. The uncertainty is the RSS of the ConvF uncertainty at calibration frequency and the uncertainty for the indicated frequency band. Frequency validity below 300 MHz is ± 10, 25, 40, 50 and 70 MHz for ConvF assessments at 30, 64, 128, 150 and 220 MHz respectively. Above 5 GHz frequency validity can be extended to ± 110 MHz.

^F At frequencies below 3 GHz, the validity of tissue parameters (ϵ and σ) can be relaxed to ± 10% if liquid compensation formula is applied to measured SAR values. At frequencies above 3 GHz, the validity of tissue parameters (ϵ and σ) is restricted to ± 5%. The uncertainty is the RSS of the ConvF uncertainty for indicated target tissue parameters.

^G Alpha/Depth are determined during calibration. SPEAG warrants that the remaining deviation due to the boundary effect after compensation is always less than ± 1% for frequencies below 3 GHz and below ± 2% for frequencies between 3-6 GHz at any distance larger than half the probe tip diameter from the boundary.

Frequency Response of E-Field (TEM-Cell:ifi110 EXX, Waveguide: R22)

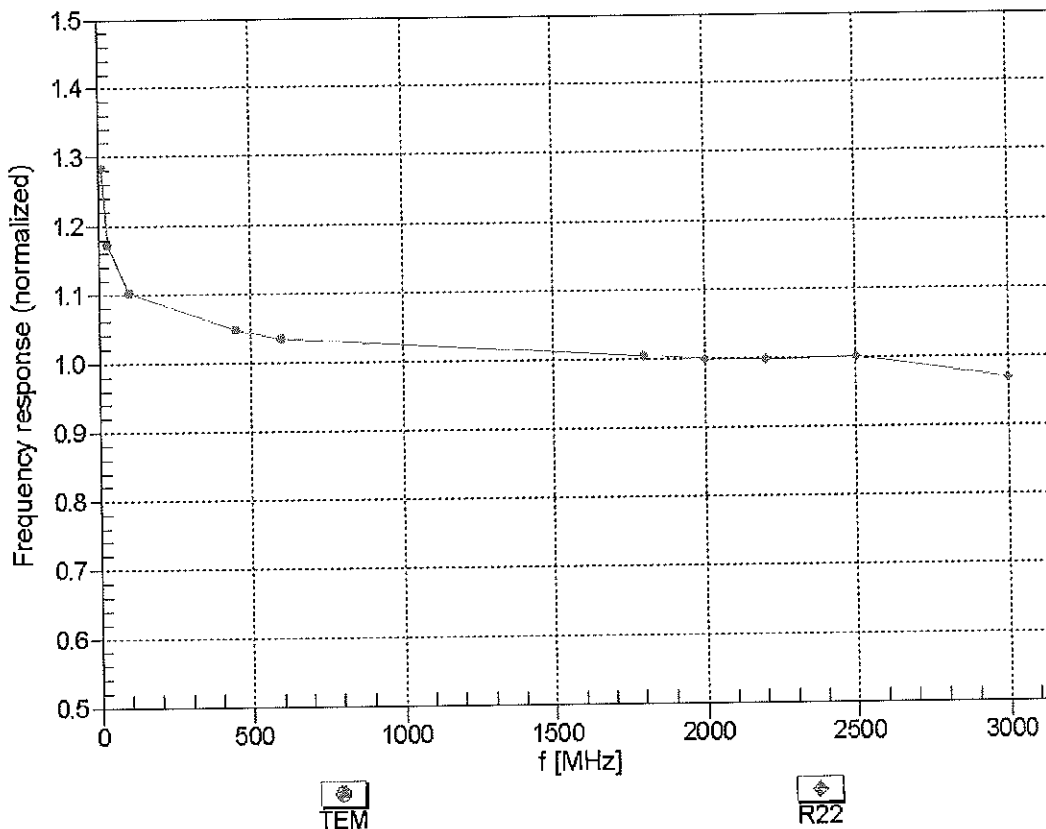

Uncertainty of Frequency Response of E-field: $\pm 6.3\%$ (k=2)

Receiving Pattern (ϕ), $\theta = 0^\circ$

f=600 MHz, TEM

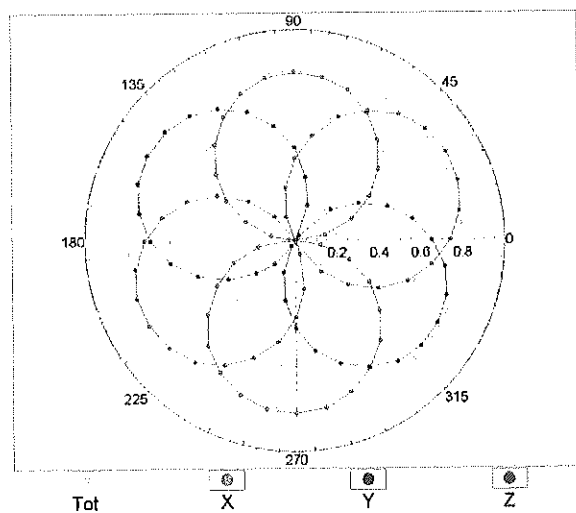

f=1800 MHz, R22

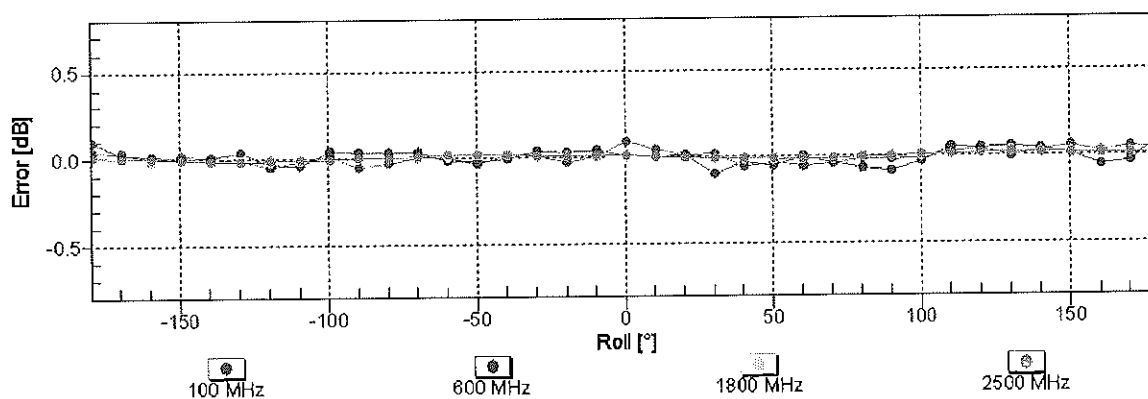
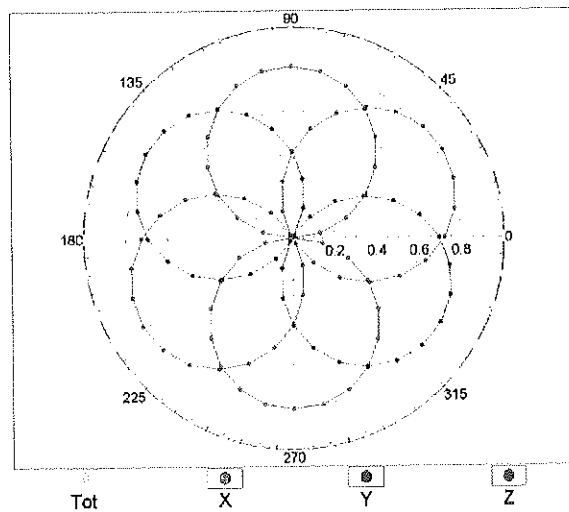

Uncertainty of Axial Isotropy Assessment: $\pm 0.5\%$ ($k=2$)

Dynamic Range f(SAR_{head}) (TEM cell , f_{eval}= 1900 MHz)

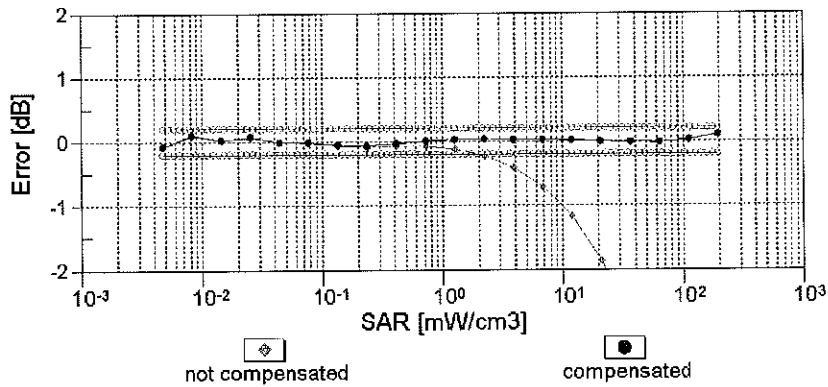
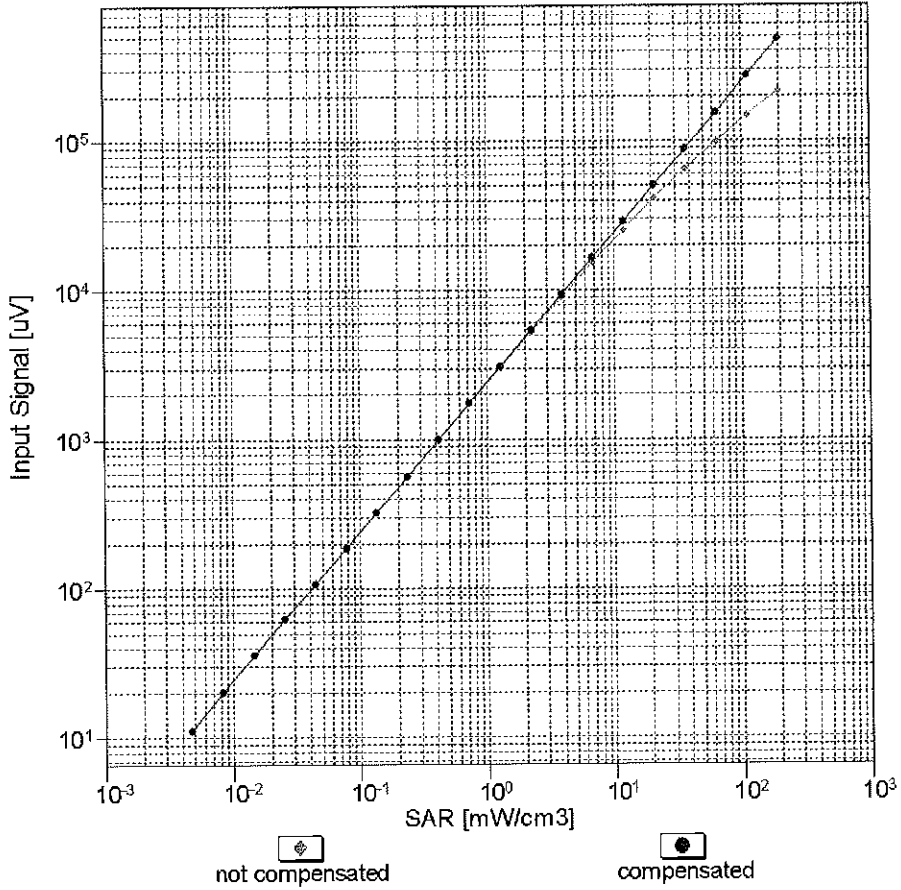

Uncertainty of Linearity Assessment: ± 0.6% (k=2)

Conversion Factor Assessment

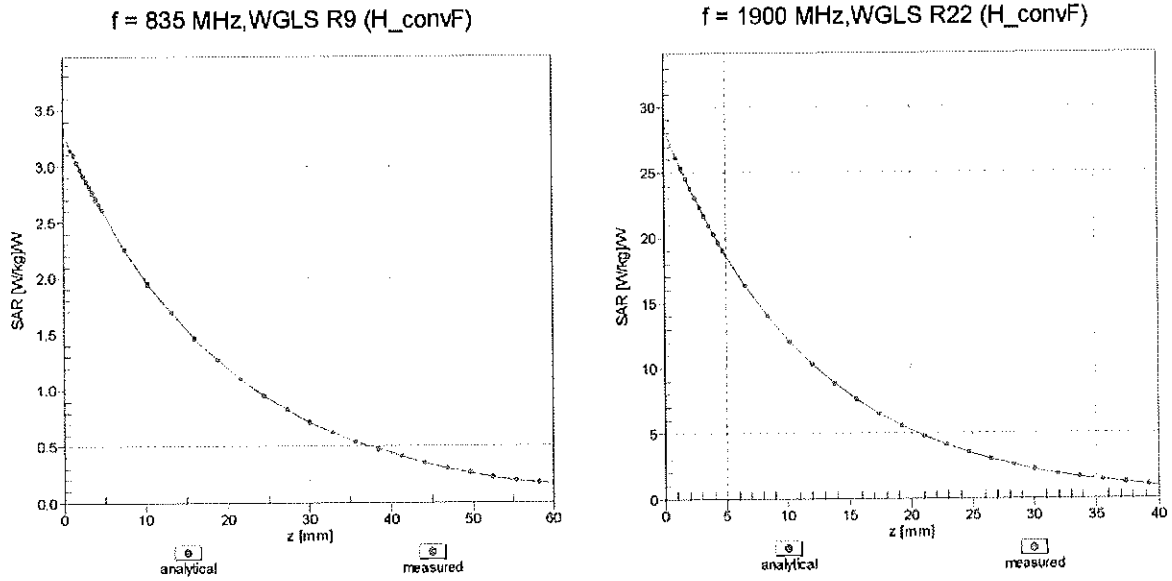

Deviation from Isotropy in Liquid Error (ϕ, θ), f = 900 MHz

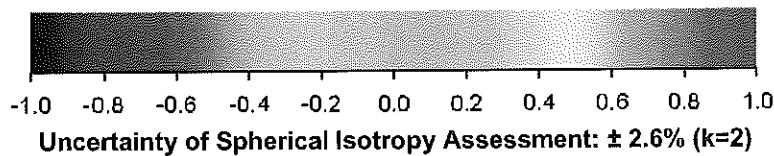
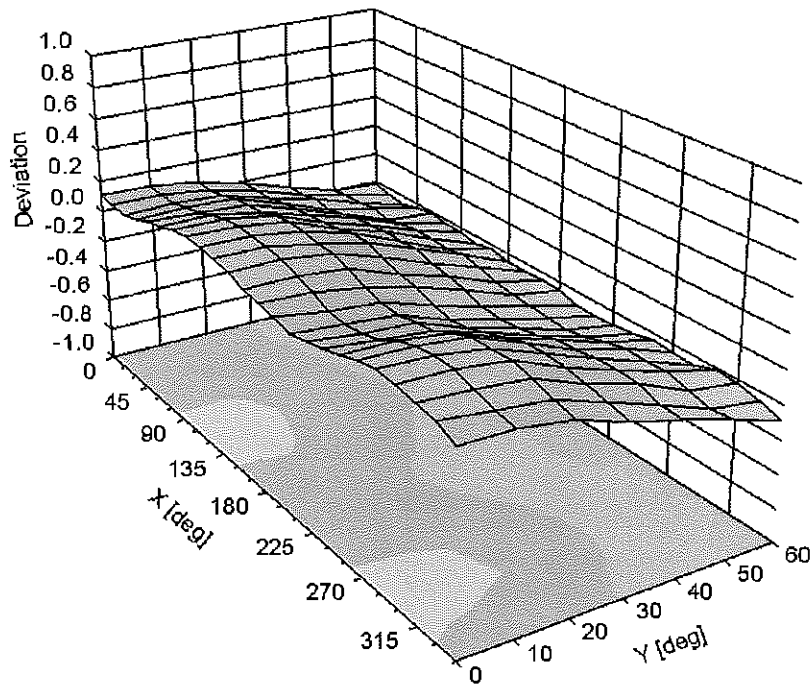

DASY/EASY - Parameters of Probe: EX3DV4 - SN:3914**Other Probe Parameters**

Sensor Arrangement	Triangular
Connector Angle (°)	-49.5
Mechanical Surface Detection Mode	enabled
Optical Surface Detection Mode	disabled
Probe Overall Length	337 mm
Probe Body Diameter	10 mm
Tip Length	9 mm
Tip Diameter	2.5 mm
Probe Tip to Sensor X Calibration Point	1 mm
Probe Tip to Sensor Y Calibration Point	1 mm
Probe Tip to Sensor Z Calibration Point	1 mm
Recommended Measurement Distance from Surface	1.4 mm

APPENDIX D: SAR TISSUE SPECIFICATIONS

Measurement Procedure for Tissue verification:



- 1) The network analyzer and probe system was configured and calibrated.
- 2) The probe was immersed in the tissue. The tissue was placed in a nonmetallic container. Trapped air bubbles beneath the flange were minimized by placing the probe at a slight angle.
- 3) The complex admittance with respect to the probe aperture was measured
- 4) The complex relative permittivity ϵ can be calculated from the below equation (Pournaropoulos and Misra):

$$Y = \frac{j2\omega\epsilon_r\epsilon_0}{[\ln(b/a)]^2} \int_a^b \int_a^b \int_0^\pi \cos\phi' \frac{\exp[-j\omega r(\mu_0\epsilon_r'\epsilon_0)^{1/2}]}{r} d\phi' d\rho' d\rho$$

where Y is the admittance of the probe in contact with the sample, the primed and unprimed coordinates refer to source and observation points, respectively, $r^2 = \rho^2 + \rho'^2 - 2\rho\rho' \cos\phi'$, ω is the angular frequency, and $j = \sqrt{-1}$.

**Table D-I
Composition of the Tissue Equivalent Matter**

Frequency (MHz)	750	835	1750	1900	2450	5200-5800
Tissue	Body	Body	Body	Body	Body	Body
Ingredients (% by weight)						
Bactericide	See page 2	0.1				
DGBE			31	29.44	26.7	
HEC		1				
NaCl		0.94	0.2	0.39	0.1	
Sucrose		44.9				
Polysorbate (Tween) 80						20
Water		53.06	68.8	70.17	73.2	80

FCC ID: ZNFV930		SAR EVALUATION REPORT		Reviewed by: Quality Manager
Test Dates: 06/17/15 - 06/23/15	DUT Type: Portable Tablet			APPENDIX D: Page 1 of 2

2 Composition / Information on ingredients

The Item is composed of the following ingredients:

H ₂ O	Water, 35 – 58%
Sucrose	Sugar, white, refined, 40 – 60%
NaCl	Sodium Chloride, 0 – 6%
Hydroxyethyl-cellulose	Medium Viscosity (CAS# 9004-62-0), <0.3%
Preventol-D7	Preservative: aqueous preparation, (CAS# 55965-84-9), containing 5-chloro-2-methyl-3(2H)-isothiazolone and 2-methyl-3(2H)-isothiazolone, 0.1 – 0.7%

Relevant for safety; Refer to the respective Safety Data Sheet*.

**Figure D-1
Composition of 750 Body Tissue Equivalent Matter**

Note: 750MHz liquid recipes are proprietary SPEAG. Since the composition is approximate to the actual liquids utilized, the manufacturer tissue-equivalent liquid data sheets are provided below.

Measurement Certificate / Material Test

Item Name	Body Tissue Simulating Liquid (MSL750V2)
Product No.	SL AAM 075 AA (Charge: 150223-3)
Manufacturer	SPEAG

Measurement Method

TSL dielectric parameters measured using calibrated OCP probe.

Setup Validation

Validation results were within $\pm 2.5\%$ towards the target values of Methanol.

Target Parameters

Target parameters as defined in the IEEE 1528 and IEC 62209 compliance standards.

Test Condition

Ambient	Environment temperatur (22 ± 3)°C and humidity < 70%.
TSL Temperature	22°C
Test Date	25-Feb-15
Operator	IEN



Additional Information

TSL Density	1.212 g/cm ³
TSL Heat-capacity	3.006 kJ/(kg*K)

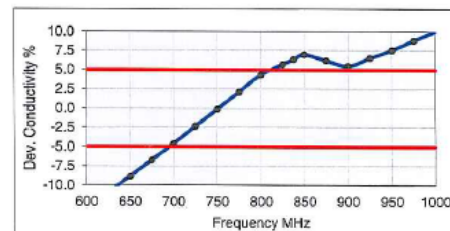
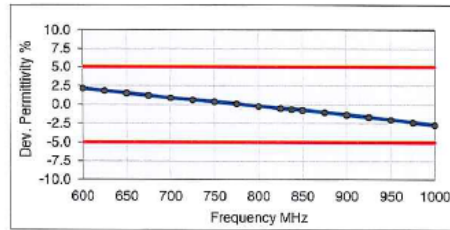
f [MHz]	Measured			Target		Diff. to Target [%]	
	HP-e'	HP-e''	sigma	eps	sigma	Δ-eps	Δ-sigma
600	57.3	24.76	0.83	56.1	0.95	2.2	-13.2
625	57.1	24.43	0.85	56.0	0.95	1.8	-11.0
650	56.8	24.09	0.87	55.9	0.96	1.5	-8.8
675	56.5	23.80	0.89	55.8	0.96	1.2	-6.7
700	56.2	23.51	0.92	55.7	0.96	0.9	-4.6
725	56.0	23.28	0.94	55.6	0.96	0.6	-2.4
750	55.7	23.06	0.96	55.5	0.96	0.4	-0.1
775	55.5	22.87	0.99	55.4	0.97	0.1	2.1
800	55.2	22.68	1.01	55.3	0.97	-0.2	4.4
825	55.0	22.52	1.03	55.2	0.98	-0.5	5.7
838	54.9	22.44	1.05	55.2	0.98	-0.6	6.3
850	54.8	22.36	1.06	55.2	0.99	-0.7	7.0
875	54.5	22.24	1.08	55.1	1.02	-1.0	6.2
900	54.3	22.12	1.11	55.0	1.05	-1.3	5.5
925	54.1	22.01	1.13	55.0	1.06	-1.6	6.5
950	53.9	21.89	1.16	54.9	1.08	-2.0	7.6
975	53.6	21.81	1.18	54.9	1.09	-2.3	8.8
1000	53.4	21.73	1.21	54.8	1.10	-2.7	10.1



**Figure D-2
750MHz Body Tissue Equivalent Matter**

FCC ID: ZNFV930		SAR EVALUATION REPORT		Reviewed by: Quality Manager
Test Dates: 06/17/15 - 06/23/15	DUT Type: Portable Tablet			APPENDIX D: Page 2 of 2

APPENDIX E: SAR SYSTEM VALIDATION



Per FCC KDB 865664 D02v01, SAR system validation status should be documented to confirm measurement accuracy. The SAR systems (including SAR probes, system components and software versions) used for this device were validated against its performance specifications prior to the SAR measurements. Reference dipoles were used with the required tissue- equivalent media for system validation, according to the procedures outlined in FCC KDB 865664 D01 v01 and IEEE 1528-2013. Since SAR probe calibrations are frequency dependent, each probe calibration point was validated at a frequency within the valid frequency range of the probe calibration point, using the system that normally operates with the probe for routine SAR measurements and according to the required tissue-equivalent media.

A tabulated summary of the system validation status including the validation date(s), measurement frequencies, SAR probes and tissue dielectric parameters has been included.



Table E-I
SAR System Validation Summary

SAR SYSTEM #	FREQ. [MHz]	DATE	PROBE SN	PROBE TYPE	PROBE CAL. POINT		COND.	PERM.	CW VALIDATION			MOD. VALIDATION		
							(σ)	(εr)	SENSITIVITY	PROBE LINEARITY	PROBE ISOTROPY	MOD. TYPE	DUTY FACTOR	PAR
A	750	1/12/2015	3331	ES3DV3	750	Body	0.975	56.380	PASS	PASS	PASS	N/A	N/A	N/A
A	835	1/12/2015	3331	ES3DV3	835	Body	0.952	53.660	PASS	PASS	PASS	GMSK	PASS	N/A
B	1750	1/4/2015	3334	ES3DV3	1750	Body	1.527	51.870	PASS	PASS	PASS	N/A	N/A	N/A
A	1900	1/12/2015	3331	ES3DV3	1900	Body	1.541	53.470	PASS	PASS	PASS	GMSK	PASS	N/A
B	2450	1/5/2015	3334	ES3DV3	2450	Body	2.044	50.900	PASS	PASS	PASS	OFDM	N/A	PASS
B	2600	1/5/2015	3334	ES3DV3	2600	Body	2.247	50.380	PASS	PASS	PASS	N/A	N/A	N/A
A	5300	2/19/2015	3914	EX3DV4	5300	Body	5.181	47.440	PASS	PASS	PASS	OFDM	N/A	PASS
A	5500	2/19/2015	3914	EX3DV4	5500	Body	5.464	46.920	PASS	PASS	PASS	OFDM	N/A	PASS
A	5800	2/19/2015	3914	EX3DV4	5800	Body	5.942	46.310	PASS	PASS	PASS	OFDM	N/A	PASS

NOTE: While the probes have been calibrated for both CW and modulated signals, all measurements were performed using communication systems calibrated for CW signals only. Modulations in the table above represent test configurations for which the measurement system has been validated per FCC KDB Publication 865664 D01v01 for scenarios when CW probe calibrations are used with other signal types. SAR systems were validated for modulated signals with a periodic duty cycle, such as GMSK, or with a high peak to average ratio (>5 dB), such as OFDM according to KDB 865664.

FCC ID: ZNFV930		SAR EVALUATION REPORT		Reviewed by: Quality Manager
Test Dates: 06/17/15 - 06/23/15	DUT Type: Portable Tablet	APPENDIX E: Page 1 of 1		

APPENDIX G: SENSOR TRIGGERING DATA SUMMARY



FCC ID: ZNFV930	 PCTEST ENGINEERING LABORATORY, INC.	SAR EVALUATION REPORT	 LG	Reviewed by: Quality Manager
Test Dates: 06/17/2015 – 06/23/2015	DUT Type: Portable Tablet			APPENDIX G: Page 1 of 6

ZNFV930 Sensor Triggering Data Summary

Per FCC KDB Publication 616217 D04v01, this device was tested by the manufacturer to determine the proximity sensor triggering distances for the back side, top edge, and right edge of the device. The measured output power within ± 5 mm of the triggering points (or until touching the phantom) is included for back side and each applicable edge.

To ensure all production units are compliant it is necessary to test SAR at a distance 1 mm less than the smallest distance from the device and SAR phantom (determined from these triggering tests according to the KDB 616217 D04v01) with the device at maximum output power without power reduction. These SAR Tests are included in addition to the SAR tests for the device touching the SAR phantom, with reduced power.

The operational description contains information explaining how this device remains compliant in the event of a sensor malfunction.

FCC ID: ZNFV930	 PCTEST ENGINEERING LABORATORY, INC.	SAR EVALUATION REPORT	 LG	Reviewed by: Quality Manager
Test Dates: 06/17/2015 – 06/23/2015	DUT Type: Portable Tablet		APPENDIX G: Page 2 of 6	

Back Side (Main Antenna LTE B12/17/5/7 and UMTS 850)



Moving device toward the phantom:

KDB 616217 6.2.8 Measured Power [dBm]											
Distance[mm]	22	21	20	19	18	17	16	15	14	13	12
WCDMA 850	24	24	24	24	24	18.5	18.5	18.5	18.5	18.5	18.5
LTE B12	24.5	24.5	24.5	24.5	24.5	18.5	18.5	18.5	18.5	18.5	18.5
LTE B17	24.5	24.5	24.5	24.5	24.5	18.5	18.5	18.5	18.5	18.5	18.5
LTE B5	24.5	24.5	24.5	24.5	24.5	18.5	18.5	18.5	18.5	18.5	18.5
LTE B7	23	23	23	23	23	12.5	12.5	12.5	12.5	12.5	12.5

Moving device away from the phantom:

KDB 616217 6.2.6 Measured Power [dBm]											
Distance[mm]	22	21	20	19	18	17	16	15	14	13	12
WCDMA 850	24.00	24.00	24.00	24.00	24.00	18.50	18.50	18.50	18.50	18.50	18.50
LTE B12	24.50	24.50	24.50	24.50	24.50	18.50	18.50	18.50	18.50	18.50	18.50
LTE B17	24.50	24.50	24.50	24.50	24.50	18.50	18.50	18.50	18.50	18.50	18.50
LTE B5	24.50	24.50	24.50	24.50	24.50	18.50	18.50	18.50	18.50	18.50	18.50
LTE B7	23.00	23.00	23.00	23.00	23.00	12.50	12.50	12.50	12.50	12.50	12.50

Based on the most conservative measured triggering distance of 17 mm, additional SAR measurements were required at 16 mm from the back side for the above modes/bands.

FCC ID: ZNFV930	 PCTEST ENGINEERING LABORATORY, INC.	SAR EVALUATION REPORT	 LG	Reviewed by: Quality Manager
Test Dates: 06/17/2015 – 06/23/2015	DUT Type: Portable Tablet		APPENDIX G: Page 3 of 6	

Back Side (Main Antenna LTE B2/4 and UMTS 1900)



Moving device toward the phantom:

KDB 616217 6.2.8 Measured Power [dBm]											
Distance[mm]	18	17	16	15	14	13	12	11	10	9	8
WCDMA 1900	24	24	24	24	24	12.5	12.5	12.5	12.5	12.5	12.5
LTE B4	25	25	25	25	25	12.5	12.5	12.5	12.5	12.5	12.5
LTE B2	25	25	25	25	25	12.5	12.5	12.5	12.5	12.5	12.5

Moving device away from the phantom:

KDB 616217 6.2.6 Measured Power [dBm]											
Distance[mm]	18	17	16	15	14	13	12	11	10	9	8
WCDMA 1900	24.00	24.00	24.00	24.00	24.00	12.50	12.50	12.50	12.50	12.50	12.50
LTE B4	25.00	25.00	25.00	25.00	25.00	12.50	12.50	12.50	12.50	12.50	12.50
LTE B2	25.00	25.00	25.00	25.00	25.00	12.50	12.50	12.50	12.50	12.50	12.50

Based on the most conservative measured triggering distance of 13 mm, additional SAR measurements were required at 12 mm from the back side for the above modes/bands.

FCC ID: ZNFV930	 PCTEST ENGINEERING LABORATORY, INC.	SAR EVALUATION REPORT	 LG	Reviewed by: Quality Manager
Test Dates: 06/17/2015 – 06/23/2015	DUT Type: Portable Tablet			APPENDIX G: Page 4 of 6

Top Edge (Main Antenna LTE B12/17/5/7 and UMTS 850)



Moving device toward the phantom:

KDB 616217 6.2.8 Measured Power [dBm]											
Distance[mm]	25	24	23	22	21	20	19	18	17	16	15
WCDMA 850	24	24	24	24	24	18.5	18.5	18.5	18.5	18.5	18.5
LTE B12	24.5	24.5	24.5	24.5	24.5	18.5	18.5	18.5	18.5	18.5	18.5
LTE B17	24.5	24.5	24.5	24.5	24.5	18.5	18.5	18.5	18.5	18.5	18.5
LTE B5	24.5	24.5	24.5	24.5	24.5	18.5	18.5	18.5	18.5	18.5	18.5
LTE B7	23	23	23	23	23	12.5	12.5	12.5	12.5	12.5	13.5

Moving device away from the phantom:

KDB 616217 6.2.6 Measured Power [dBm]											
Distance[mm]	25	24	23	22	21	20	19	18	17	16	15
WCDMA 850	24.00	24.00	24.00	24.00	24.00	18.50	18.50	18.50	18.50	18.50	18.50
LTE B12	24.50	24.50	24.50	24.50	24.50	18.50	18.50	18.50	18.50	18.50	18.50
LTE B17	24.50	24.50	24.50	24.50	24.50	18.50	18.50	18.50	18.50	18.50	18.50
LTE B5	24.50	24.50	24.50	24.50	24.50	18.50	18.50	18.50	18.50	18.50	18.50
LTE B7	23.00	23.00	23.00	23.00	23.00	12.50	12.50	12.50	12.50	12.50	13.50

Based on the most conservative measured triggering distance of 20 mm, additional SAR measurements were required at 19 mm from the top edge for the above modes/bands.

FCC ID: ZNFV930	 PCTEST ENGINEERING LABORATORY, INC.	SAR EVALUATION REPORT	 LG	Reviewed by: Quality Manager
Test Dates: 06/17/2015 – 06/23/2015	DUT Type: Portable Tablet		APPENDIX G: Page 5 of 6	

Right Edge (Main Antenna LTE B2/4 and UMTS 1900)



Moving device toward the phantom:

KDB 616217 6.2.8 Measured Power [dBm]											
Distance[mm]	20	19	18	17	16	15	14	13	12	11	10
WCDMA 1900	24	24	24	24	24	12.5	12.5	12.5	12.5	12.5	12.5
LTE B4	25	25	25	25	25	12.5	12.5	12.5	12.5	12.5	12.5
LTE B2	25	25	25	25	25	12.5	12.5	12.5	12.5	12.5	12.5

Moving device away from the phantom:

KDB 616217 6.2.6 Measured Power [dBm]											
Distance[mm]	20	19	18	17	16	15	14	13	12	11	10
WCDMA 1900	24.00	24.00	24.00	24.00	24.00	12.50	12.50	12.50	12.50	12.50	12.50
LTE B4	25.00	25.00	25.00	25.00	25.00	12.50	12.50	12.50	12.50	12.50	12.50
LTE B2	25.00	25.00	25.00	25.00	25.00	12.50	12.50	12.50	12.50	12.50	12.50

Based on the most conservative measured triggering distance of 15 mm, additional SAR measurements were required at 14 mm from the right edge for the above modes/bands.

FCC ID: ZNFV930	 PCTEST ENGINEERING LABORATORY, INC.	SAR EVALUATION REPORT	 LG	Reviewed by: Quality Manager
Test Dates: 06/17/2015 – 06/23/2015	DUT Type: Portable Tablet		APPENDIX G: Page 6 of 6	