

# TEST REPORT



**DT&C Co., Ltd.**

42, Yurim-ro, 154Beon-gil, Cheoin-gu, Yongin-si, Gyeonggi-do, Korea, 17042  
Tel : 031-321-2664, Fax : 031-321-1664

1. Report No : DRTFCC2002-0044(1)
2. Customer
  - Name : LG Electronics USA, Inc.
  - Address : 1000 Sylvan Ave. Englewood Cliffs, New Jersey, United States 07632
3. Use of Report : FCC Original Grant
4. Product Name / Model Name : Mobile Phone / LM-V600EA  
FCC ID : ZNFV600EA
5. Test Method Used : KDB971168 D01v03, ANSI/TIA-603-E-2016, ANSI C63.26-2015  
Test Specification : §2, §22, §24(E), §27
6. Date of Test : 2019.12.19 ~ 2020.01.30
7. Testing Environment : Refer to appended test report.
8. Test Result : Refer to the attached test result.

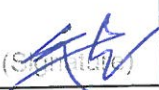
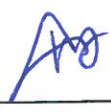
Affirmation	Tested by Name : JaeHyeok Bang  (Signature)	Reviewed by Name : Guenki Son  (Signature)
-------------	---	--

The test results presented in this test report are limited only to the sample supplied by applicant and the use of this test report is inhibited other than its purpose. This test report shall not be reproduced except in full, without the written approval of DT&C Co., Ltd.

2020 . 02 . 24 .

**DT&C Co., Ltd.**

If this report is required to confirmation of authenticity, please contact to [report@dtnc.net](mailto:report@dtnc.net)

## Test Report Version

Test Report No.	Date	Description	Tested by	Reviewed by
DRTFCC2002-0044	Feb. 14, 2020	Initial issue	JaeHyeok Bang	Guenki Son
DRTFCC2002-0044(1)	Feb. 24, 2020	Revised the section 6	JaeHyeok Bang	Guenki Son

## Table of Contents

<b>1. GENERAL INFORMATION .....</b>	<b>5</b>
<b>2. INTRODUCTION .....</b>	<b>7</b>
2.1 EUT DESCRIPTION .....	7
2.2. EUT CAPABILITIES .....	7
2.3. TESTING ENVIRONMENT .....	7
2.4 MEASURING INSTRUMENT CALIBRATION.....	7
2.5. MEASUREMENT UNCERTAINTY .....	7
2.6. TEST FACILITY.....	7
<b>3. DESCRIPTION OF TESTS.....</b>	<b>8</b>
3.1 ERP & EIRP (Effective Radiated Power & Equivalent Isotropic Radiated Power) .....	8
3.2 PEAK TO AVERAGE RATIO .....	10
3.3 OCCUPIED BANDWIDTH.....	11
3.4 BAND EDGE EMISSIONS AT ANTENNA TERMINAL .....	12
3.5 SPURIOUS AND HARMONIC EMISSIONS AT ANTENNA TERMINAL .....	13
3.6 UNDESIRABLE EMISSIONS .....	14
3.7 FREQUENCY STABILITY .....	15
<b>4. LIST OF TEST EQUIPMENT .....</b>	<b>16</b>
<b>5. SUMMARY OF TEST RESULTS .....</b>	<b>17</b>
<b>6. SAMPLE CALCULATION .....</b>	<b>18</b>
<b>7. TEST DATA.....</b>	<b>21</b>
7.1 OCCUPIED BANDWIDTH.....	21
7.2 PEAK TO AVERAGE RATIO.....	21
7.3 BAND EDEG EMISSIONS (Conducted).....	21
7.4 SPURIOUS AND HARMONICS EMISSIONS (Conducted) .....	21
7.5 ERP & EIRP .....	22
7.5.1 LTE Band 12, 17.....	22
7.5.2 LTE Band 12.....	23
7.5.3 LTE Band 5.....	24
7.5.4 LTE Band 4.....	26
7.5.5 LTE Band 2.....	29
7.6 UNDESIRABLE EMISSIONS (Radiated).....	32
7.6.1 LTE Band 12, 17.....	32
7.6.2 LTE Band 5.....	34
7.6.3 LTE Band 4.....	36
7.6.4 LTE Band 2.....	38
7.7 FREQUENCY STABILITY .....	40
7.7.1 LTE Band 12, 17.....	40
7.8.2 LTE Band 5.....	41
7.7.3 LTE Band 4.....	42

7.7.4 LTE Band 2.....	43
<b>8. TEST PLOTS .....</b>	<b>44</b>
8.1 OCCUPIED BANDWIDTH.....	44
8.1.1 LTE Band 12, 17.....	44
8.1.2 LTE Band 12.....	48
8.1.3 LTE Band 5.....	52
8.1.3 LTE Band 4.....	60
8.1.5 LTE Band 2.....	72
8.2 PEAK TO AVERAGE RATIO .....	84
8.2.1 LTE Band 12, 17.....	84
8.2.2 LTE Band 12.....	88
8.2.3 LTE Band 5.....	92
8.2.4 LTE Band 4.....	100
8.2.5 LTE Band 2.....	112
8.3 BAND EDGE EMISSIONS(Conducted).....	124
8.3.1 LTE Band 12, 17.....	124
8.3.2 LTE Band 12.....	128
8.3.3 LTE Band 5.....	132
8.3.4 LTE Band 4.....	140
8.3.5 LTE Band 2.....	152
8.4 SPURIOUS AND HARMONICS EMISSIONS(Conducted) .....	164
8.4.1 LTE Band 12, 17.....	164
8.4.2 LTE Band 12.....	167
8.4.3 LTE Band 5.....	171
8.4.4 LTE Band 4.....	177
8.4.5 LTE Band 2.....	195

## 1. GENERAL INFORMATION

**Applicant Name** : LG Electronics USA, Inc.  
**Address** : 1000 Sylvan Ave. Englewood Cliffs, New Jersey, United States 07632  
**FCC ID** : ZNFV600EA  
**FCC Classification** : PCS Licensed Transmitter held to ear (PCE)  
**EUT Type** : Mobile Phone  
**Model Name** : LM-V600EA  
**Add Model Name** : LMV600EA, V600EA  
**Supplying power** : DC 3.87 V  
**Antenna Information** : PIFA Antenna

Mode	TX Frequency (MHz)	Emission Designator	Modulation	ERP	
				Max power (dBm)	Max power (W)
LTE Band 12, 17	704 ~ 711	8M93G7D	QPSK	21.01	0.126
LTE Band 12, 17	704 ~ 711	8M93W7D	16QAM	19.30	0.085
LTE Band 12, 17	704 ~ 711	8M96W7D	64QAM	18.29	0.067
LTE Band 12, 17	701.5 ~ 713.5	4M48G7D	QPSK	20.72	0.118
LTE Band 12, 17	701.5 ~ 713.5	4M49W7D	16QAM	19.05	0.080
LTE Band 12, 17	701.5 ~ 713.5	4M48W7D	64QAM	18.07	0.064
LTE Band 12	700.5 ~ 714.5	2M69G7D	QPSK	20.92	0.124
LTE Band 12	700.5 ~ 714.5	2M69W7D	16QAM	19.49	0.089
LTE Band 12	700.5 ~ 714.5	2M69W7D	64QAM	18.39	0.069
LTE Band 12	699.7 ~ 715.3	1M09G7D	QPSK	22.95	0.197
LTE Band 12	699.7 ~ 715.3	1M09W7D	16QAM	19.58	0.091
LTE Band 12	699.7 ~ 715.3	1M08W7D	64QAM	18.56	0.072
LTE Band 5	829 ~ 844	8M95G7D	QPSK	20.08	0.102
LTE Band 5	829 ~ 844	8M93W7D	16QAM	18.40	0.069
LTE Band 5	829 ~ 844	8M95W7D	64QAM	17.21	0.053
LTE Band 5	826.5 ~ 846.5	4M48G7D	QPSK	20.00	0.100
LTE Band 5	826.5 ~ 846.5	4M48W7D	16QAM	18.90	0.078
LTE Band 5	826.5 ~ 846.5	4M49W7D	64QAM	17.44	0.055
LTE Band 5	825.5 ~ 847.5	2M69G7D	QPSK	20.18	0.104
LTE Band 5	825.5 ~ 847.5	2M70W7D	16QAM	18.43	0.070
LTE Band 5	825.5 ~ 847.5	2M69W7D	64QAM	17.34	0.054
LTE Band 5	824.7 ~ 848.3	1M09G7D	QPSK	19.95	0.099
LTE Band 5	824.7 ~ 848.3	1M09W7D	16QAM	18.38	0.069
LTE Band 5	824.7 ~ 848.3	1M09W7D	64QAM	17.51	0.056

Mode	TX Frequency (MHz)	Emission Designator	Modulation	EIRP	
				Max power (dBm)	Max power (W)
LTE Band 4	1720 ~ 1745	17M9G7D	QPSK	21.55	0.143
LTE Band 4	1720 ~ 1745	17M9W7D	16QAM	20.72	0.118
LTE Band 4	1720 ~ 1745	17M9W7D	64QAM	19.79	0.095
LTE Band 4	1717.5 ~ 1747.5	13M4G7D	QPSK	21.64	0.146
LTE Band 4	1717.5 ~ 1747.5	13M4W7D	16QAM	21.00	0.126
LTE Band 4	1717.5 ~ 1747.5	13M4W7D	64QAM	19.99	0.100
LTE Band 4	1715 ~ 1750	8M96G7D	QPSK	21.85	0.153
LTE Band 4	1715 ~ 1750	8M95W7D	16QAM	21.24	0.133
LTE Band 4	1715 ~ 1750	8M96W7D	64QAM	20.55	0.114
LTE Band 4	1712.5 ~ 1752.5	4M48G7D	QPSK	21.43	0.139
LTE Band 4	1712.5 ~ 1752.5	4M50W7D	16QAM	20.96	0.125
LTE Band 4	1712.5 ~ 1752.5	4M49W7D	64QAM	19.85	0.097
LTE Band 4	1711.5 ~ 1753.5	2M69G7D	QPSK	21.80	0.151
LTE Band 4	1711.5 ~ 1753.5	2M70W7D	16QAM	21.03	0.127
LTE Band 4	1711.5 ~ 1753.5	2M69W7D	64QAM	19.94	0.099
LTE Band 4	1710.7 ~ 1754.3	1M09G7D	QPSK	20.60	0.115
LTE Band 4	1710.7 ~ 1754.3	1M09W7D	16QAM	19.98	0.100
LTE Band 4	1710.7 ~ 1754.3	1M09W7D	64QAM	18.92	0.078
LTE Band 2	1860 ~ 1900	17M9G7D	QPSK	21.84	0.153
LTE Band 2	1860 ~ 1900	17M9W7D	16QAM	21.22	0.132
LTE Band 2	1860 ~ 1900	17M9W7D	64QAM	20.08	0.102
LTE Band 2	1857.5 ~ 1902.5	13M4G7D	QPSK	21.46	0.140
LTE Band 2	1857.5 ~ 1902.5	13M4W7D	16QAM	20.61	0.115
LTE Band 2	1857.5 ~ 1902.5	13M4W7D	64QAM	19.80	0.095
LTE Band 2	1855 ~ 1905	8M96G7D	QPSK	22.13	0.163
LTE Band 2	1855 ~ 1905	8M95W7D	16QAM	21.45	0.140
LTE Band 2	1855 ~ 1905	8M94W7D	64QAM	20.55	0.114
LTE Band 2	1852.5 ~ 1907.5	4M48G7D	QPSK	22.08	0.161
LTE Band 2	1852.5 ~ 1907.5	4M50W7D	16QAM	21.26	0.134
LTE Band 2	1852.5 ~ 1907.5	4M49W7D	64QAM	20.27	0.106
LTE Band 2	1851.5 ~ 1908.5	2M69G7D	QPSK	21.80	0.151
LTE Band 2	1851.5 ~ 1908.5	2M69W7D	16QAM	21.11	0.129
LTE Band 2	1851.5 ~ 1908.5	2M70W7D	64QAM	20.31	0.107
LTE Band 2	1850.7 ~ 1909.3	1M09G7D	QPSK	21.30	0.135
LTE Band 2	1850.7 ~ 1909.3	1M09W7D	16QAM	20.63	0.116
LTE Band 2	1850.7 ~ 1909.3	1M09W7D	64QAM	19.60	0.091

## 2. INTRODUCTION

### 2.1 EUT DESCRIPTION

The Equipment Under Test (EUT) supports GSM/WCDMA/LTE Phone with Bluetooth, WLAN, NFC, WPC.

### 2.2. EUT CAPABILITIES

This EUT contains the following capabilities:

850/1900 GSM/EDGE 850/1900 WCDMA/HSUPA, Multi-band LTE, 802.11b/g/n/ac/ax WLAN(2.4GHz)  
802.11a/n/ac/ax WLAN(5GHz), Bluetooth(BDR, EDR, LE), NFC, WPC, Dual Display.

### 2.3. TESTING ENVIRONMENT

Ambient Condition	
▪ Temperature	+21 °C ~ +25 °C
▪ Relative Humidity	41 % ~ 45 %

### 2.4 MEASURING INSTRUMENT CALIBRATION

The measuring equipment, which was utilized in performing the tests documented herein, has been calibrated in accordance with the manufacturer's recommendations for utilizing calibration equipment, which is traceable to recognized national standards.

### 2.5. MEASUREMENT UNCERTAINTY

The measurement uncertainties shown below were calculated in accordance with requirements of ANSI C 63.4-2014. All measurement uncertainty values are shown with a coverage factor of  $k = 2$  to indicate a 95 % level of confidence.

Parameter	Measurement uncertainty
Radiated Disturbance (Below 1 GHz)	5.1 dB (The confidence level is about 95 %, $k = 2$ )
Radiated Disturbance (1 GHz ~ 18 GHz)	5.4 dB (The confidence level is about 95 %, $k = 2$ )
Radiated Disturbance (Above 18 GHz)	5.3 dB (The confidence level is about 95 %, $k = 2$ )

### 2.6. TEST FACILITY

<b>DT&amp;C Co., Ltd.</b>	
The 3 m test site and conducted measurement facility used to collect the radiated data are located at the 42, Yurim-ro, 154beon-gil, Cheoin-gu, Yongin-si, Gyeonggi-do, Korea 17042. The test site comply with the requirements of § 2.948 according to ANSI 63.4-2014.	
<b>- FCC MRA Accredited Test Firm No. : KR0034</b>	
<a href="http://www.dtnc.net">www.dtnc.net</a>	
Telephone	: + 82-31-321-2664
FAX	: + 82-31-321-1664

### 3. DESCRIPTION OF TESTS

#### 3.1 ERP & EIRP (Effective Radiated Power & Equivalent Isotropic Radiated Power)

##### Test Set-up

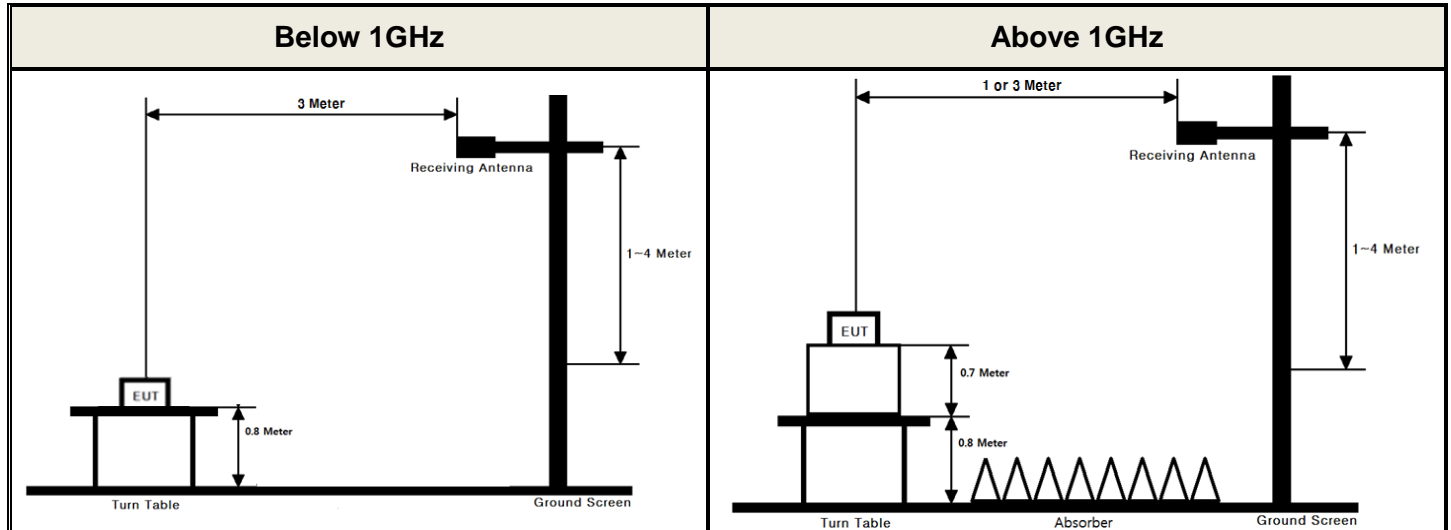

These measurements were performed at 3 m test site. The equipment under test is placed on a non-conductive table 1.5-meters above a turntable which is flush with the ground plane and 3 meters from the receive antenna. For measurements above 1GHz absorbers are placed on the floor between the turn table and the antenna mast in such a way so as to maximize the reduction of reflections. For measurements below 1 GHz, the absorbers are removed.

##### Test Procedure

- ANSI/TIA-603-E-2016 - Section 2.2.17
- KDB971168 D01v03 - Section 5.2.2
- ANSI C63.26-2015 – Section 5.2.4.4.1

##### Test setting

1. Set span to 2 x to 3 x the OBW.
2. Set RBW = 1% to 5% of the OBW.
3. Set VBW  $\geq$  3 x RBW.
4. Set number of points in sweep  $\geq$  2 x span / RBW.
5. Sweep time:
  - 1) Set = auto-couple, or
  - 2) Set  $\geq$   $[10 \times (\text{number of points in sweep}) \times (\text{transmission period})]$  for single sweep (automation-compatible) measurement. Transmission period is the on and off time of the transmitter.
6. Detector = power averaging (rms).
7. If the EUT can be configured to transmit continuously, then set the trigger to free run.
8. If the EUT cannot be configured to transmit continuously, then use a sweep trigger with the level set to enable triggering only on full power bursts and configure the EUT to transmit at full power for the entire duration of each sweep. Verify that the sweep time is less than or equal to the transmission burst duration. Time gating can also be used under similar constraints (i.e., configured such that measurement data is collected only during active full-power transmissions).
9. Trace average at least 100 traces in power averaging (rms) mode if sweep is set to auto-couple. To accurately determine the average power over multiple symbols, it can be necessary to increase the number of traces to be averaged above 100 or, if using a manually configured sweep time, increase the sweep time.



10. Compute the power by integrating the spectrum across the OBW of the signal using the instrument's band or channel power measurement function, with the band/channel limits set equal to the OBW band edges. If the instrument does not have a band or channel power function, then sum the spectrum levels (in linear power units) at intervals equal to the RBW extending across the entire OBW of the spectrum.

The receiver antenna height and turntable rotations were adjusted for the highest reading on the receive spectrum analyzer.

A half-wave dipole was substituted in place of the EUT. This dipole antenna was driven by a signal generator and the level of the signal generator was adjusted to obtain the same receive spectrum analyzer reading. The conducted power at the terminal of the substitute antenna is measured.

The ERP/EIRP is calculated using the following formula:

**ERP/EIRP = The conducted power at the substitute antenna's terminal [dBm] + Substitute Antenna gain [dBd for ERP , dBi for EIRP]**

For readings above 1 GHz, the above procedure is repeated using horn antennas and the difference between the gain of the horn antenna and an isotropic antenna are taken into consideration.

## 3.2 PEAK TO AVERAGE RATIO

### Test set-up

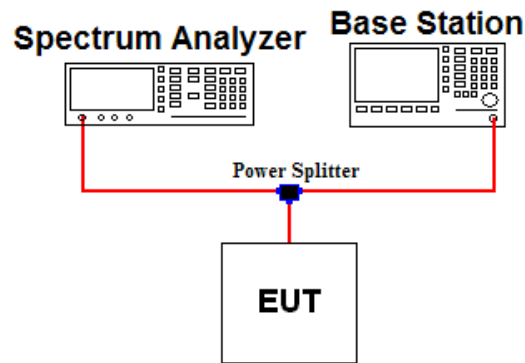

### Test Procedure

- KDB971168 D01v03 - Section 5.7.2
- ANSI C63.26-2015 – Section 5.2.3.4

A peak to average ratio measurement is performed at the conducted port of the EUT.

The spectrum analyzers Complementary Cumulative Distribution Function (CCDF) measurement profile is used to determine the largest deviation between the average and the peak power of the EUT in a given bandwidth. The CCDF curve shows how much time the peak waveform spends at or above a given average power level. The present of time the signal spends at or above the level defines the probability for that particular power level.

### Test setting

The spectrum Analyzer's CCDF measurement function is enabled.

1. Set resolution/measurement bandwidth  $\geq$  OBW or specified reference bandwidth.
2. Set the number of counts to a value that stabilizes the measured CCDF curve.
3. Set the measurement interval as follows:
  - 1) For continuous transmissions, set to the greater of  $[10 \times (\text{number of points in sweep}) \times (\text{transmission symbol period})]$  or 1 ms.
  - 2) For burst transmissions, employ an external trigger that is synchronized with the EUT burst timing sequence, or use the internal burst trigger with a trigger level that allows the burst to stabilize. Set the measurement interval to a time that is less than or equal to the burst duration.
  - 3) If there are several carriers in a single antenna port, the peak power shall be determined for each individual carrier (by disabling the other carriers while measuring the required carrier) and the total peak power calculated from the sum of the individual carrier peak powers.
4. Record the maximum PAPR level associated with a probability of 0.1%.
5. The peak power level is calculated from the sum of the PAPR value from step d) to the measured average power.

### 3.3 OCCUPIED BANDWIDTH.

#### *Test set-up*

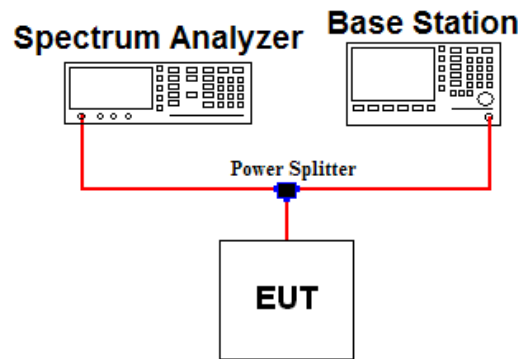

#### *Test Procedure*

- KDB971168 D01v03 - Section 4.3
- ANSI C63.26-2015 – Section 5.4.4

The occupied bandwidth, that is the frequency bandwidth such that, below its lower and above its upper frequency limits, the mean powers radiated are each equal to 0.5 percent of the total mean power of a given emission.

#### Test setting

1. The signal analyzer's automatic bandwidth measurement capability was used to perform the 99 % occupied bandwidth and the 26 dB bandwidth. The bandwidth measurement was not influenced by any intermediate power nulls in the fundamental emission.
2.  $RBW = 1 \sim 5 \%$  of the expected OBW &  $VBW \geq 3 \times RBW$
3. Detector = Peak
4. Trace mode = Max hold
5. Sweep = Auto couple
6. The trace was allowed to stabilize
7. If necessary, step 2 ~ 6 were repeated after changing the RBW such that it would be within 1 ~ 5 % of the 99 % occupied bandwidth observed in step 6.

### 3.4 BAND EDGE EMISSIONS AT ANTENNA TERMINAL

#### Test set-up

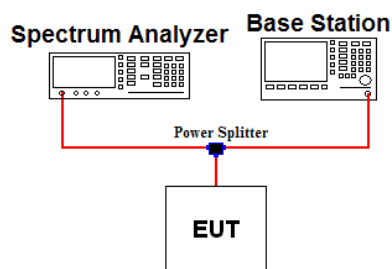

#### Test Procedure

- KDB971168 D01v03 - Section 6
- ANSI C63.26-2015 – Section 5.7

All out of band emissions are measured by means of a calibrated spectrum analyzer. The EUT was setup to maximum output power at its lowest and highest channel with all bandwidths, modulations and RB configurations.

The power of any spurious emission shall be attenuated below the transmitter power (P) by at least  $43 + 10 \log(P)$  dB.

#### Test setting

1. Start and stop frequency were set such that the band edge would be placed in the center of the plot
2. Span was set large enough so as to capture all out of band emissions near the band edge
3. RBW  $\geq 1\%$  of the emission bandwidth
4. VBW  $\geq 3 \times$  RBW
5. Detector = RMS & Trace mode = Max hold
6. Sweep time = Auto couple or 1 s for band edge
7. Number of sweep point  $\geq 2 \times$  span / RBW
8. The trace was allowed to stabilize

Note 1: Per Part 22.917(b)(1) / 24.238(b) / 27.53(h) in the 1 MHz bands immediately outside and adjacent to the frequency block a resolution bandwidth of at least one percent of the emission bandwidth of the fundamental emission of the transmitter may be employed to demonstrate compliance with the out-of-band emissions limit.

The emission bandwidth is defined as the width of the signal between two points, one below the carrier center frequency and one above the carrier center frequency, outside of which all emission are attenuated at least 26 dB below the transmitter power.

Note 2: Per Part 27(g) for operations in the 600 MHz band and the 698-746 MHz band, compliance with this provision is based on the use of measurement instrumentation employing a resolution bandwidth of 100 kilohertz or greater. However, in the 100 kilohertz bands immediately outside and adjacent to a licensee's frequency block, a resolution bandwidth of at least 30 kHz may be employed.

Note 3: For part 27.53(m)(4) the attenuation factor shall be not less than  $40 + 10 \log(P)$  dB on all frequencies between the channel edge and 5 megahertz from the channel edge,  $43 + 10 \log(P)$  dB on all frequencies between 5 megahertz and X megahertz from the channel edge, and  $55 + 10 \log(P)$  dB on all frequencies more than X megahertz from the channel edge, where X is the greater of 6 megahertz or the actual emission bandwidth as defined in paragraph (m)(6) of this section. In addition, the attenuation factor shall not be less than  $43 + 10 \log(P)$  dB on all frequencies between 2490.5 MHz and 2496 MHz and  $55 + 10 \log(P)$  dB at or below 2490.5 MHz.

Note 4: Per part 27.53(m)(6) in the 1 MHz bands immediately outside and adjacent to the frequency block a resolution bandwidth of at least two percent may be employed, except when the 1 MHz band is 2495-2496 MHz, in which case a resolution bandwidth of at least one percent may be employed.

### 3.5 SPURIOUS AND HARMONIC EMISSIONS AT ANTENNA TERMINAL

#### Test set-up

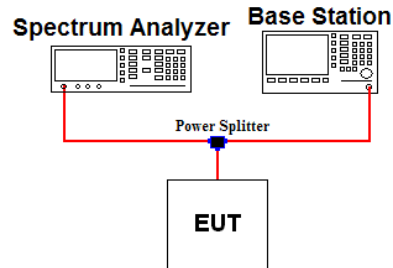

#### Test Procedure

- KDB971168 D01v03 - Section 6
- ANSI C63.26-2015 – Section 5.7

The level of the carrier and the various conducted spurious and harmonic frequencies is measured by means of a calibrated spectrum analyzer. The EUT was setup to maximum output power at its low, middle, high channel with all bandwidths, modulations and RB configurations. The spectrum is scanned from 9 kHz up to a frequency including its 10<sup>th</sup> harmonic.

The power of any spurious emission shall be attenuated below the transmitter power (P) by at least  $43 + 10 \log(P)$  dB.

#### Test setting

1. RBW = 100 kHz(Below 1 GHz) or 1 MHz(Above 1 GHz) & VBW  $\geq 3 \times$  RBW ( Refer to Note 1)
2. Detector = RMS & Trace mode = Max hold
3. Sweep time = Auto couple
4. Number of sweep point  $\geq 2 \times$  span / RBW
5. The trace was allowed to stabilize

Note 1: Compliance with these provisions is based on the use of measurement instrumentation employing a resolution bandwidth of 100 kHz or greater for frequencies less than 1GHz and 1MHz or greater for frequencies greater than 1GHz.

### 3.6 UNDESIRABLE EMISSIONS

#### Test Set-up

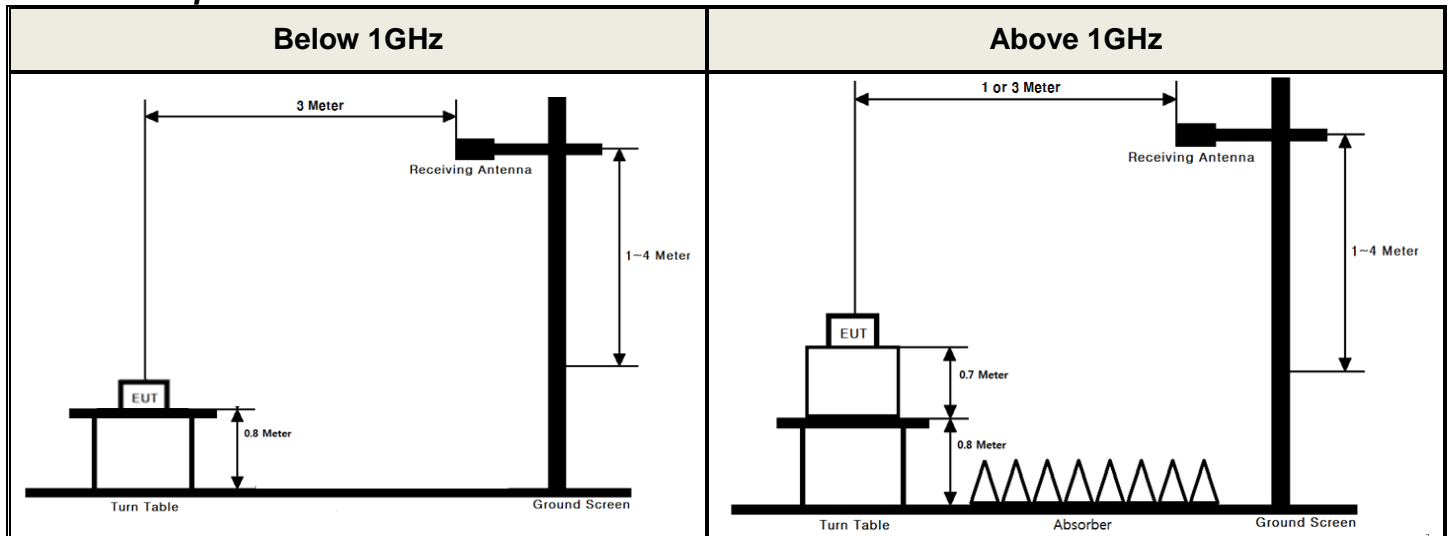

These measurements were performed at 3 test site. The equipment under test is placed on a non-conductive table 1.5-meters above a turntable which is flush with the ground plane and 3 meters from the receive antenna. For measurements above 1 GHz absorbers are placed on the floor between the turn table and the antenna mast in such a way so as to maximize the reduction of reflections. For measurements below 1 GHz, the absorbers are removed.

#### Test Procedure

- ANSI/TIA-603-E-2016 - Section 2.2.12
- KDB971168 D01v03 - Section 5.8
- ANSI C63.26-2015 – Section 5.5

#### Test setting

1. RBW = 100 kHz for below 1 GHz and 1 MHz for above 1 GHz / VBW  $\geq$  3 X RBW
2. Detector = RMS & Trace mode = Max hold
3. Sweep time = Auto couple
4. Number of sweep point  $\geq$  2 X span / RBW
5. The trace was allowed to stabilize

The receive antenna height and turntable rotations were adjusted for the highest reading on the receive spectrum analyzer.

For radiated power measurements below 1 GHz, a half-wave dipole was substituted in place of the EUT. This dipole antenna was driven by a signal generator and the level of the signal generator was adjusted to obtain the same spectrum analyzer reading.

For radiated power measurements above 1 GHz, a Horn antenna was substituted in place of the EUT. This Horn antenna was driven by a signal generator and the level of the signal generator was adjusted to obtain the same spectrum analyzer reading. The difference between the gain of the horn and an isotropic antenna are taken into consideration.

This measurement was performed with the EUT oriented in 3 orthogonal axis.

### 3.7 FREQUENCY STABILITY

#### Test Set-up

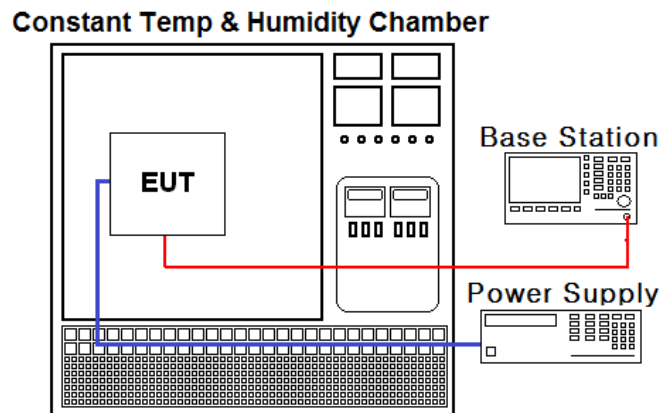

#### Test Procedure

- ANSI/TIA-603-E-2016
- KDB971168 D01v03 - Section 9

The frequency stability of the transmitter is measured by:

a.) **Temperature:**

The temperature is varied from - 30 °C to + 50 °C using an environmental chamber.

b.) **Primary Supply Voltage:**

The primary supply voltage is varied from 85 % to 115 % of the nominal value for non hand-carried battery and AC powered equipment. For hand-carried, battery-powered equipment, primary supply voltage is reduced to the battery operating end point which shall be specified by the manufacturer.

#### Specification:

The frequency stability shall be sufficient to ensure that the fundamental emission stays within the authorized frequency block for Part 24, 27. The frequency stability of the transmitter shall be maintained within  $\pm 0.00025\%$  ( $\pm 2.5$  ppm) of the center frequency for Part 22.

#### Time Period and Procedure:

1. The carrier frequency of the transmitter is measured at room temperature.  
(20 °C to provide a reference)
2. The equipment is turned on in a "standby" condition for one minute before applying power to the transmitter. Measurement of the carrier frequency of the transmitter is made within one minute after applying power to the transmitter.
3. Frequency measurements are made at 10 °C intervals ranging from -30 °C to +50 °C.  
A period of at least one half-hour is provided to allow stabilization of the equipment at each temperature level.

#### 4. LIST OF TEST EQUIPMENT

Type	Manufacturer	Model	Cal.Date (yy/mm/dd)	Next.Cal. Date (yy/mm/dd)	S/N
Spectrum Analyzer	Agilent Technologies	N9020A	19/06/26	20/06/26	MY46471251
Spectrum Analyzer	Agilent Technologies	N9020A	19/06/26	20/06/26	MY50410163
DC power supply	Agilent Technologies	66332A	19/06/25	20/06/25	MY43001172
Multimeter	FLUKE	17B+	18/12/18 19/12/17	19/12/18 20/12/17	36390701WS
Power Splitter	Anritus	K241B	18/12/19 19/12/18	19/12/19 20/12/18	016681
Temp & Humi	SJ Science	SJ-TH-S50	19/06/25	20/06/25	U5542113
Radio Communication Analyzer	Anritus	MT8820C	19/06/26	20/06/26	6201127429
Thermohygrometer	BODYCOM	BJ5478	18/12/27 19/12/16	19/12/27 20/12/16	120612-2
Thermohygrometer	BODYCOM	BJ5478	18/12/27 19/12/16	19/12/27 20/12/16	120612-1
Signal Generator	Rohde Schwarz	SMBV100A	18/12/19 19/12/16	19/12/19 20/12/16	255571
Signal Generator	ANRITSU	MG3695C	18/12/20 19/12/16	19/12/20 20/12/16	173501
Loop Antenna	ETS-Lindgren	6502	19/09/18	21/09/18	00226186
Bilog Antenna	Schwarzbeck	VULB 9160	19/04/23	21/04/23	9160-3362
Dipole Antenna	Schwarzbeck	VHA9103	19/02/28	21/02/28	2116
Dipole Antenna	Schwarzbeck	VHA9103	18/04/13	20/04/13	2117
Dipole Antenna	Schwarzbeck	UHA9105	19/02/28	21/02/28	2261
Dipole Antenna	Schwarzbeck	UHA9105	18/04/13	20/04/13	2262
HORN ANT	ETS	3117	18/05/10	20/05/10	00140394
HORN ANT	ETS	3117	18/03/26	20/03/26	00152145
HORN ANT	A.H.Systems	SAS-574	19/04/23	21/04/23	154
HORN ANT	A.H.Systems	SAS-574	19/07/03	21/07/03	155
Amplifier	EMPOWER	BBS3Q7ELU	19/06/24	20/06/24	1020
PreAmplifier	H.P	8447D	18/12/18 19/12/16	19/12/18 20/12/16	2944A07774
PreAmplifier	Agilent	8449B	19/06/27	20/06/27	3008A02108
High-pass filter	Wainwright	WHKX12-935-1000-15000-40SS	19/06/24	20/06/24	7
High-pass filter	Wainwright	WHKX12-2580-3000-18000-80SS	19/06/24	20/06/24	3
High-pass filter	Wainwright	WHNX8.5/26.5G-6SS	19/06/24	20/06/24	1
Cable	DTNC	Cable	19/01/16 20/01/13	20/01/16 21/01/13	M-01
Cable	DTNC	Cable	19/01/16 20/01/13	20/01/16 21/01/13	M-02
Cable	Junkosha	MWX315	19/01/16 20/01/13	20/01/16 21/01/13	M-05
Cable	Junkosha	MWX221	19/01/16 20/01/13	20/01/16 21/01/13	M-06
Cable	DTNC	Cable	19/01/16 20/01/13	20/01/16 21/01/13	RF-84

Note1: The measurement antennas were calibrated in accordance to the requirements of ANSI C63.5-2017.

Note2: The cable is not a regular calibration item, so it has been calibrated by DT & C itself.



## 5. SUMMARY OF TEST RESULTS

FCC Part Section(s)	Test Description	Test Limit	Test Condition	Status Note 1
2.1046	Conducted Output Power	N/A	Conducted	<b>C</b> Note2
2.1049	Occupied Bandwidth	N/A		<b>C</b>
24.232(d) 27.50(d.5)	Peak to Average Ratio	< 13 dB		<b>C</b>
2.1051 22.917(a) 24.238(a) 27.53(g) 27.53(h)	Band Edge / Conducted Spurious Emissions	> 43 + 10log <sub>10</sub> (P) dB at Band edge and for all out-of-band emissions		<b>C</b>
2.1055 22.355 24.235 27.54	Frequency Stability	< 2.5 ppm (Part 22) Fundamental emissions must stay within Authorized frequency block (Part 24, 27)		<b>C</b>
27.50(c.10)	Radiated Output Power (B12, 17)	< 3 Watts max. ERP	Radiated	<b>C</b>
22.913(a.5)	Radiated Output Power (B5)	< 7 Watts max. ERP		<b>C</b>
27.50(d.4)	Radiated Output Power (B4)	< 1 Watts max. EIRP		<b>C</b>
24.232(c)	Radiated Output Power(B2)	< 2 Watts max. EIRP		<b>C</b>
2.1053 22.917(a) 24.238(a) 27.53(g) 27.53(h)	Undesirable Emissions	> 43 + 10log <sub>10</sub> (P) dB for all out-of-band emissions		<b>C</b>

Note 1: **C**=Comply **NC**=Not Comply **NT**=Not Tested **NA**=Not Applicable

Note 2: Refer to RF Exposure Report (Test Report SAR)

Note 3: This device supports wireless charging & Can use Dual Screen.

So per KDB648474 D03v01r04, the radiated test items were performed all not charging, charging and Dual Screen conditions. For wireless charging condition, the handset is placed on the representative charging pad under normal conditions and in a simulated call configuration.

And the worst case data was reported.

## 6. SAMPLE CALCULATION

### A. Emission Designator

#### LTE Band 12, 17(QPSK)

Emission Designator = **8M93G7D**  
LTE OBW = 8.934 MHz  
G = Phase Modulation  
7 = Quantized/Digital Info  
D = Data Transmission

#### LTE Band 12, 17(64QAM)

Emission Designator = **8M96W7D**  
LTE OBW = 8.960 MHz  
W = Amplitude/Angle Modulated  
7 = Quantized/Digital Info  
D = Data Transmission

#### LTE Band 5(QPSK)

Emission Designator = **8M95G7D**  
LTE OBW = 8.952 MHz  
G = Phase Modulation  
7 = Quantized/Digital Info  
D = Data Transmission

#### LTE Band 5(64QAM)

Emission Designator = **8M95W7D**  
LTE OBW = 8.952 MHz  
W = Amplitude/Angle Modulated  
7 = Quantized/Digital Info  
D = Data Transmission

#### LTE Band 4(QPSK)

Emission Designator = **17M9G7D**  
LTE OBW = 17.875 MHz  
G = Phase Modulation  
7 = Quantized/Digital Info  
D = Data Transmission

#### LTE Band 4(64QAM)

Emission Designator = **17M9W7D**  
LTE OBW = 17.863 MHz  
W = Amplitude/Angle Modulated  
7 = Quantized/Digital Info  
D = Data Transmission

#### LTE Band 12, 17(16QAM)

Emission Designator = **8M93W7D**  
LTE OBW = 8.932 MHz  
W = Amplitude/Angle Modulated  
7 = Quantized/Digital Info  
D = Data Transmission

#### LTE Band 5(16QAM)

Emission Designator = **8M93W7D**  
LTE OBW = 8.933 MHz  
W = Amplitude/Angle Modulated  
7 = Quantized/Digital Info  
D = Data Transmission

#### LTE Band 4(16QAM)

Emission Designator = **17M9W7D**  
LTE OBW = 17.879 MHz  
W = Amplitude/Angle Modulated  
7 = Quantized/Digital Info  
D = Data Transmission

**LTE Band 2(QPSK)**Emission Designator = **17M9G7D**

LTE OBW = 17.881 MHz

G = Phase Modulation

7 = Quantized/Digital Info

D = Data Transmission

**LTE Band 2(16QAM)**Emission Designator = **17M9W7D**

LTE OBW = 17.886 MHz

W = Amplitude/Angle Modulated

7 = Quantized/Digital Info

D = Data Transmission

**LTE Band 2(64QAM)**Emission Designator = **17M9W7D**

LTE OBW = 17.858 MHz

W = Amplitude/Angle Modulated

7 = Quantized/Digital Info

D = Data Transmission

## **B. For substitution method**

- 1) The EUT was placed on a turntable with 0.8 meter height for frequency below 1GHz and 1.5 meter height for frequency above 1 GHz respectively above ground.
- 2) The EUT was set 3 meters from the receiving antenna mounted on the antenna tower.
- 3) During the test, the turn table is rotated until the maximum signal is found.
- 4) Record the field strength meter's level. (ex. Spectrum reading level is -8.5 dBm)
- 5) Replace the EUT with dipole/Horn antenna that is connected to a calibrated signal generator.
- 6) Increase the signal generator output till the field strength meter's level is equal to the item (4).  
(ex. Signal generator level is -18.04 dBm)
- 7) The gain of the cable and amplifier between the signal generator and terminals of substituted antenna is 46.92 dB at test frequency.
- 8) Record the level at substituted antenna terminal. (ex. 28.88dBm)
- 9) The result is calculated as below;

$$\text{EIRP(dBm)} = \text{LEVLE@ANTENNA TERMINAL} + \text{TX Antenna Gain (dBi)}$$

$$\text{ERP(dBm)} = \text{LEVLE@ANTENNA TERMINAL} + \text{TX Antenna Gain (dBd)}$$

$$\text{Where, TX Antenna Gain (dBd)} = \text{TX Antenna Gain (dBi)} - 2.15 \text{ dB}$$

## 7. TEST DATA

### 7.1 OCCUPIED BANDWIDTH

- Plots of the EUT's Occupied Bandwidth are shown in Clause 8.1

### 7.2 PEAK TO AVERAGE RATIO

- Plots of the EUT's Peak- to- Average Ratio are shown in Clause 8.2

### 7.3 BAND EDGE EMISSIONS (Conducted)

- Plots of the EUT's Band Edge Emissions are shown in Clause 8.3

### 7.4 SPURIOUS AND HARMONICS EMISSIONS (Conducted)

- Plots of the EUT's Spurious Emissions are shown in Clause 8.4

## 7.5 ERP & EIRP

### 7.5.1 LTE Band 12, 17

- Measurement data: Without wireless charging pad

Channel Bandwidth (MHz)	Test Frequency (MHz)	Test Mode	RB Size/ Offset	Ant Pol (H/V)	Level(dBm) @ Ant Terminal	TX Ant Gain (dBd)	ERP (dBm)	ERP (W)	Note
10	704	QPSK	1/49	H	20.31	-0.65	19.66	0.092	-
		16QAM	1/49	H	18.97	-0.65	18.32	0.068	-
		64QAM	1/49	H	17.66	-0.65	17.01	0.050	-
	711	QPSK	1/49	H	21.64	-0.63	21.01	0.126	-
		16QAM	1/49	H	19.93	-0.63	19.30	0.085	-
		64QAM	1/49	H	18.92	-0.63	18.29	0.067	-
5	701.5	QPSK	1/12	H	18.42	-0.66	17.76	0.060	-
		16QAM	1/12	H	16.63	-0.66	15.97	0.040	-
		64QAM	1/12	H	15.62	-0.66	14.96	0.031	-
	707.5	QPSK	1/12	H	20.04	-0.64	19.40	0.087	-
		16QAM	1/12	H	18.54	-0.64	17.90	0.062	-
		64QAM	1/12	H	17.26	-0.64	16.62	0.046	-
	713.5	QPSK	1/12	H	21.34	-0.62	20.72	0.118	-
		16QAM	1/12	H	19.67	-0.62	19.05	0.080	-
		64QAM	1/12	H	18.69	-0.62	18.07	0.064	-

Note: This device was tested under all bandwidths, modulations and RB configurations and the worst case data are reported in the table above.

### 7.5.2 LTE Band 12

#### - Measurement data: Without wireless charging pad

Channel Bandwidth (MHz)	Test Frequency (MHz)	Test Mode	RB Size/ Offset	Ant Pol (H/V)	Level(dBm) @ Ant Terminal	TX Ant Gain (dBd)	ERP (dBm)	ERP (W)	Note
3	700.5	QPSK	1/7	H	18.04	-0.66	17.38	0.055	-
		16QAM	1/7	H	16.38	-0.66	15.72	0.037	-
		64QAM	1/7	H	15.38	-0.66	14.72	0.030	-
	707.5	QPSK	1/7	H	20.30	-0.64	19.66	0.092	-
		16QAM	1/7	H	18.70	-0.64	18.06	0.064	-
		64QAM	1/7	H	17.87	-0.64	17.23	0.053	-
	714.5	QPSK	1/7	H	21.54	-0.62	20.92	0.124	-
		16QAM	1/7	H	20.11	-0.62	19.49	0.089	-
		64QAM	1/7	H	19.01	-0.62	18.39	0.069	-
1.4	699.7	QPSK	1/2	H	18.03	-0.66	17.37	0.055	-
		16QAM	1/2	H	16.49	-0.66	15.83	0.038	-
		64QAM	1/2	H	15.48	-0.66	14.82	0.030	-
	707.5	QPSK	1/2	H	20.38	-0.64	19.74	0.094	-
		16QAM	1/2	H	18.77	-0.64	18.13	0.065	-
		64QAM	1/2	H	17.63	-0.64	16.99	0.050	-
	715.3	QPSK	1/2	H	21.74	-0.62	21.12	0.129	-
		16QAM	1/2	H	20.20	-0.62	19.58	0.091	-
		64QAM	1/2	H	19.18	-0.62	18.56	0.072	-
QPSK		1/2	H	20.70	-0.62	20.08	0.102	With Dual Display (180°)	

Note: This device was tested under all bandwidths, modulations and RB configurations and the worst case data are reported in the table above.

#### - Measurement data: With wireless charging pad

Channel Bandwidth (MHz)	Test Frequency (MHz)	Test Mode	RB Size/ Offset	Ant Pol (H/V)	Level(dBm) @ Ant Terminal	TX Ant Gain (dBd)	ERP (dBm)	ERP (W)	Note
10	711	QPSK	1/49	H	19.20	-0.63	18.57	0.072	-
		16QAM	1/49	H	17.72	-0.63	17.09	0.051	-
		64QAM	1/49	H	16.58	-0.63	15.95	0.039	-
5	713.5	QPSK	1/12	H	18.79	-0.62	18.17	0.066	-
		16QAM	1/12	H	17.08	-0.62	16.46	0.044	-
		64QAM	1/12	H	16.11	-0.62	15.49	0.035	-
3	714.5	QPSK	1/7	H	18.94	-0.62	18.32	0.068	-
		16QAM	1/7	H	17.32	-0.62	16.70	0.047	-
		64QAM	1/7	H	16.29	-0.62	15.67	0.037	-
1.4	715.3	QPSK	1/2	H	19.17	-0.62	18.55	0.072	-
		16QAM	1/2	H	17.67	-0.62	17.05	0.051	-
		64QAM	1/2	H	16.43	-0.62	15.81	0.038	-
		QPSK	1/2	H	23.57	-0.62	22.95	0.197	With Dual Display (180°)

Note1: This device was tested under all bandwidths, modulations and RB configurations and the worst case data are reported in the table above.

### 7.5.3 LTE Band 5

#### - Measurement data: Without wireless charging pad

Channel Bandwidth (MHz)	Test Frequency (MHz)	Test Mode	RB Size/ Offset	Ant Pol (H/V)	Level(dBm) @ Ant Terminal	TX Ant Gain (dBd)	ERP (dBm)	ERP (W)	Note
10	829	QPSK	1/25	H	17.98	-0.67	17.31	0.054	-
		16QAM	1/25	H	16.52	-0.67	15.85	0.038	-
		64QAM	1/25	H	15.34	-0.67	14.67	0.029	-
	836.5	QPSK	1/25	H	20.13	-0.74	19.39	0.087	-
		16QAM	1/25	H	18.59	-0.74	17.85	0.061	-
		64QAM	1/25	H	17.18	-0.74	16.44	0.044	-
	844	QPSK	1/25	H	20.13	-0.81	19.32	0.086	-
		16QAM	1/25	H	18.74	-0.81	17.93	0.062	-
		64QAM	1/25	H	17.54	-0.81	16.73	0.047	-
5	826.5	QPSK	1/12	H	17.81	-0.65	17.16	0.052	-
		16QAM	1/12	H	16.48	-0.65	15.83	0.038	-
		64QAM	1/12	H	14.95	-0.65	14.30	0.027	-
	836.5	QPSK	1/12	H	20.47	-0.74	19.73	0.094	-
		16QAM	1/12	H	18.83	-0.74	18.09	0.064	-
		64QAM	1/12	H	17.89	-0.74	17.15	0.052	-
	846.5	QPSK	1/12	H	20.27	-0.83	19.44	0.088	-
		16QAM	1/12	H	19.73	-0.83	18.90	0.078	-
		64QAM	1/12	H	17.59	-0.83	16.76	0.047	-
3	825.5	QPSK	1/7	H	17.90	-0.64	17.26	0.053	-
		16QAM	1/7	H	16.47	-0.64	15.83	0.038	-
		64QAM	1/7	H	15.12	-0.64	14.48	0.028	-
	836.5	QPSK	1/7	H	20.66	-0.74	19.92	0.098	-
		16QAM	1/7	H	19.12	-0.74	18.38	0.069	-
		64QAM	1/7	H	18.02	-0.74	17.28	0.053	-
	847.5	QPSK	1/7	H	19.62	-0.74	18.88	0.077	With Dual Display (90°)
		16QAM	1/7	H	20.37	-0.84	19.53	0.090	-
		64QAM	1/7	H	18.72	-0.84	17.88	0.061	-
1.4	824.7	QPSK	1/2	H	17.84	-0.63	17.21	0.053	-
		16QAM	1/2	H	16.19	-0.63	15.56	0.036	-
		64QAM	1/2	H	15.31	-0.63	14.68	0.029	-
	836.5	QPSK	1/2	H	20.46	-0.74	19.72	0.094	-
		16QAM	1/2	H	18.96	-0.74	18.22	0.066	-
		64QAM	1/2	H	17.89	-0.74	17.15	0.052	-
	848.3	QPSK	1/2	H	20.02	-0.85	19.17	0.083	-
		16QAM	1/2	H	18.93	-0.85	18.08	0.064	-
		64QAM	1/2	H	17.47	-0.85	16.62	0.046	-

Note: This device was tested under all bandwidths, modulations and RB configurations and the worst case data are reported in the table above.



**- Measurement data: With wireless charging pad**

Channel Bandwidth (MHz)	Test Frequency (MHz)	Test Mode	RB Size/ Offset	Ant Pol (H/V)	Level(dBm) @ Ant Terminal	TX Ant Gain (dBc)	ERP (dBm)	ERP (W)	Note
10	836.5	QPSK	1/25	H	20.82	-0.74	20.08	0.102	-
		16QAM	1/25	H	19.14	-0.74	18.40	0.069	-
		64QAM	1/25	H	17.95	-0.74	17.21	0.053	-
5	836.5	QPSK	1/12	H	20.74	-0.74	20.00	0.100	-
		16QAM	1/12	H	19.08	-0.74	18.34	0.068	-
		64QAM	1/12	H	18.18	-0.74	17.44	0.055	-
3	836.5	QPSK	1/7	H	20.92	-0.74	20.18	0.104	-
		16QAM	1/7	H	19.17	-0.74	18.43	0.070	-
		64QAM	1/7	H	18.08	-0.74	17.34	0.054	-
		QPSK	1/7	H	18.59	-0.74	17.85	0.061	With Dual Display (90°)
1.4	848.3	QPSK	1/2	H	20.69	-0.74	19.95	0.099	-
		16QAM	1/2	H	19.12	-0.74	18.38	0.069	-
		64QAM	1/2	H	18.25	-0.74	17.51	0.056	-

Note1: This device was tested under all bandwidths, modulations and RB configurations and the worst case data are reported in the table above.

### 7.5.4 LTE Band 4

#### - Measurement data: Without wireless charging pad

Channel Bandwidth (MHz)	Test Frequency (MHz)	Test Mode	RB Size/Offset	Ant Pol (H/V)	Level(dBm) @ Ant Terminal	TX Ant Gain (dBi)	EIRP (dBm)	EIRP (W)	Note
20	1720	QPSK	1/50	H	14.13	5.95	20.08	0.102	-
		16QAM	1/50	H	13.92	5.95	19.87	0.097	-
		64QAM	1/50	H	13.11	5.95	19.06	0.081	-
	1732.5	QPSK	1/50	H	14.54	5.84	20.38	0.109	-
		16QAM	1/50	H	14.01	5.84	19.85	0.097	-
		64QAM	1/50	H	13.12	5.84	18.96	0.079	-
	1745	QPSK	1/50	H	15.14	5.73	20.87	0.122	-
		16QAM	1/50	H	14.55	5.73	20.28	0.107	-
		64QAM	1/50	H	13.34	5.73	19.07	0.081	-
15	1717.5	QPSK	1/36	H	14.64	5.97	20.61	0.115	-
		16QAM	1/36	H	13.86	5.97	19.83	0.096	-
		64QAM	1/36	H	12.60	5.97	18.57	0.072	-
	1732.5	QPSK	1/36	H	14.83	5.84	20.67	0.117	-
		16QAM	1/36	H	14.39	5.84	20.23	0.105	-
		64QAM	1/36	H	13.38	5.84	19.22	0.084	-
	1747.5	QPSK	1/36	H	15.58	5.70	21.28	0.134	-
		16QAM	1/36	H	14.66	5.70	20.36	0.109	-
		64QAM	1/36	H	13.88	5.70	19.58	0.091	-
		QPSK	1/36	H	14.83	5.70	20.53	0.113	With Dual Display (180°)
10	1715	QPSK	1/25	H	14.13	6.00	20.13	0.103	-
		16QAM	1/25	H	13.19	6.00	19.19	0.083	-
		64QAM	1/25	H	12.40	6.00	18.40	0.069	-
	1732.5	QPSK	1/25	H	14.49	5.84	20.33	0.108	-
		16QAM	1/25	H	14.02	5.84	19.86	0.097	-
		64QAM	1/25	H	12.72	5.84	18.56	0.072	-
	1750	QPSK	1/25	H	14.87	5.68	20.55	0.114	-
		16QAM	1/25	H	14.12	5.68	19.80	0.095	-
		64QAM	1/25	H	13.12	5.68	18.80	0.076	-

Note: This device was tested under all bandwidths, modulations and RB configurations and the worst case data are reported in the table above.

Channel Bandwidth (MHz)	Test Frequency (MHz)	Test Mode	RB Size/Offset	Ant Pol (H/V)	Level(dBm) @ Ant Terminal	TX Ant Gain (dBi)	EIRP (dBm)	EIRP (W)	Note
5	1712.5	QPSK	1/12	H	13.45	6.02	19.47	0.089	-
		16QAM	1/12	H	12.71	6.02	18.73	0.075	-
		64QAM	1/12	H	11.76	6.02	17.78	0.060	-
	1732.5	QPSK	1/12	H	14.84	5.84	20.68	0.117	-
		16QAM	1/12	H	13.94	5.84	19.78	0.095	-
		64QAM	1/12	H	13.02	5.84	18.86	0.077	-
	1752.5	QPSK	1/12	H	14.65	5.65	20.30	0.107	-
		16QAM	1/12	H	13.97	5.65	19.62	0.092	-
		64QAM	1/12	H	13.02	5.65	18.67	0.074	-
3	1711.5	QPSK	1/7	H	13.51	6.03	19.54	0.090	-
		16QAM	1/7	H	12.63	6.03	18.66	0.073	-
		64QAM	1/7	H	11.45	6.03	17.48	0.056	-
	1732.5	QPSK	1/7	H	14.67	5.84	20.51	0.112	-
		16QAM	1/7	H	14.03	5.84	19.87	0.097	-
		64QAM	1/7	H	12.63	5.84	18.47	0.070	-
	1753.5	QPSK	1/7	H	15.03	5.63	20.66	0.116	-
		16QAM	1/7	H	14.29	5.63	19.92	0.098	-
		64QAM	1/7	H	13.22	5.63	18.85	0.077	-
1.4	1710.7	QPSK	1/2	H	13.51	6.03	19.54	0.090	-
		16QAM	1/2	H	12.74	6.03	18.77	0.075	-
		64QAM	1/2	H	11.82	6.03	17.85	0.061	-
	1732.5	QPSK	1/2	H	14.19	5.84	20.03	0.101	-
		16QAM	1/2	H	13.66	5.84	19.50	0.089	-
		64QAM	1/2	H	12.37	5.84	18.21	0.066	-
	1754.3	QPSK	1/2	H	14.98	5.62	20.60	0.115	-
		16QAM	1/2	H	14.36	5.62	19.98	0.100	-
		64QAM	1/2	H	13.30	5.62	18.92	0.078	-

Note: This device was tested under all bandwidths, modulations and RB configurations and the worst case data are reported in the table above.

**- Measurement data: With wireless charging pad**

Channel Bandwidth (MHz)	Test Frequency (MHz)	Test Mode	RB Size/Offset	Ant Pol (H/V)	Level(dBm) @ Ant Terminal	TX Ant Gain (dBi)	EIRP (dBm)	EIRP (W)	Note
20	1745	QPSK	1/50	H	15.82	5.73	21.55	0.143	-
		16QAM	1/50	H	14.99	5.73	20.72	0.118	-
		64QAM	1/50	H	14.06	5.73	19.79	0.095	-
15	1747.5	QPSK	1/36	H	15.94	5.70	21.64	0.146	-
		16QAM	1/36	H	15.30	5.70	21.00	0.126	-
		64QAM	1/36	H	14.29	5.70	19.99	0.100	-
		QPSK	1/36	H	14.02	5.70	19.72	0.094	With Dual Display (180°)
10	1750	QPSK	1/25	H	16.17	5.68	21.85	0.153	-
		16QAM	1/25	H	15.56	5.68	21.24	0.133	-
		64QAM	1/25	H	14.54	5.68	20.22	0.105	-
5	1732.5	QPSK	1/12	H	15.59	5.84	21.43	0.139	-
		16QAM	1/12	H	15.12	5.84	20.96	0.125	-
		64QAM	1/12	H	14.01	5.84	19.85	0.097	-
3	1753.5	QPSK	1/7	H	16.17	5.63	21.80	0.151	-
		16QAM	1/7	H	15.40	5.63	21.03	0.127	-
		64QAM	1/7	H	14.31	5.63	19.94	0.099	-
1.4	1754.3	QPSK	1/2	H	14.09	5.62	19.71	0.094	-
		16QAM	1/2	H	13.57	5.62	19.19	0.083	-
		64QAM	1/2	H	12.56	5.62	18.18	0.066	-

Note1: This device was tested under all bandwidths, modulations and RB configurations and the worst case data are reported in the table above.

## 7.5.5 LTE Band 2

### - Measurement data: Without wireless charging pad

Channel Bandwidth (MHz)	Test Frequency (MHz)	Test Mode	RB Size/Offset	Ant Pol (H/V)	Level(dBm) @ Ant Terminal	TX Ant Gain (dBi)	EIRP (dBm)	EIRP (W)	Note
20	1860	QPSK	1/0	V	14.62	4.91	19.53	0.090	-
		16QAM	1/0	V	13.96	4.91	18.87	0.077	-
		64QAM	1/0	V	12.98	4.91	17.89	0.062	-
	1880	QPSK	1/0	V	14.59	4.80	19.39	0.087	-
		16QAM	1/0	V	14.04	4.80	18.84	0.077	-
		64QAM	1/0	V	12.92	4.80	17.72	0.059	-
	1900	QPSK	1/0	V	16.29	4.69	20.98	0.125	-
		16QAM	1/0	V	15.60	4.69	20.29	0.107	-
		64QAM	1/0	V	14.91	4.69	19.60	0.091	-
15	1857.5	QPSK	1/0	V	14.47	4.92	19.39	0.087	-
		16QAM	1/0	V	13.97	4.92	18.89	0.077	-
		64QAM	1/0	V	12.82	4.92	17.74	0.059	-
	1880	QPSK	1/0	V	14.87	4.80	19.67	0.093	-
		16QAM	1/0	V	14.34	4.80	19.14	0.082	-
		64QAM	1/0	V	13.11	4.80	17.91	0.062	-
	1902.5	QPSK	1/0	V	15.79	4.68	20.47	0.111	-
		16QAM	1/0	V	14.90	4.68	19.58	0.091	-
		64QAM	1/0	V	13.98	4.68	18.66	0.073	-
10	1855	QPSK	1/25	V	14.21	4.94	19.15	0.082	-
		16QAM	1/25	V	13.48	4.94	18.42	0.070	-
		64QAM	1/25	V	12.27	4.94	17.21	0.053	-
	1880	QPSK	1/25	V	14.78	4.80	19.58	0.091	-
		16QAM	1/25	V	14.21	4.80	19.01	0.080	-
		64QAM	1/25	V	13.09	4.80	17.89	0.062	-
	1905	QPSK	1/25	V	15.40	4.67	20.07	0.102	-
		16QAM	1/25	V	14.83	4.67	19.50	0.089	-
		64QAM	1/25	V	13.85	4.67	18.52	0.071	-

Note: This device was tested under all bandwidths, modulations and RB configurations and the worst case data are reported in the table above.

Channel Bandwidth (MHz)	Test Frequency (MHz)	Test Mode	RB Size/Offset	Ant Pol (H/V)	Level(dBm) @ Ant Terminal	TX Ant Gain (dBi)	EIRP (dBm)	EIRP (W)	Note
5	1852.5	QPSK	1/12	V	14.30	4.95	19.25	0.084	-
		16QAM	1/12	V	13.30	4.95	18.25	0.067	-
		64QAM	1/12	V	12.36	4.95	17.31	0.054	-
	1880	QPSK	1/12	V	14.79	4.80	19.59	0.091	-
		16QAM	1/12	V	13.88	4.80	18.68	0.074	-
		64QAM	1/12	V	12.94	4.80	17.74	0.059	-
	1907.5	QPSK	1/12	V	15.58	4.65	20.23	0.105	-
		16QAM	1/12	V	15.04	4.65	19.69	0.093	-
		64QAM	1/12	V	13.33	4.65	17.98	0.063	-
3	1851.5	QPSK	1/7	V	14.27	4.95	19.22	0.084	-
		16QAM	1/7	V	13.53	4.95	18.48	0.070	-
		64QAM	1/7	V	12.59	4.95	17.54	0.057	-
	1880	QPSK	1/7	V	15.28	4.80	20.08	0.102	-
		16QAM	1/7	V	14.38	4.80	19.18	0.083	-
		64QAM	1/7	V	13.37	4.80	18.17	0.066	-
	1908.5	QPSK	1/7	V	15.52	4.65	20.17	0.104	-
		16QAM	1/7	V	14.86	4.65	19.51	0.089	-
		64QAM	1/7	V	13.80	4.65	18.45	0.070	-
1.4	1850.7	QPSK	1/2	V	14.34	4.96	19.30	0.085	-
		16QAM	1/2	V	13.57	4.96	18.53	0.071	-
		64QAM	1/2	V	12.59	4.96	17.55	0.057	-
	1880	QPSK	1/2	V	14.81	4.80	19.61	0.091	-
		16QAM	1/2	V	14.27	4.80	19.07	0.081	-
		64QAM	1/2	V	13.05	4.80	17.85	0.061	-
	1909.3	QPSK	1/2	V	16.45	4.64	21.09	0.129	-
		16QAM	1/2	V	15.67	4.64	20.31	0.107	-
		64QAM	1/2	V	14.62	4.64	19.26	0.084	-
		QPSK	1/2	V	15.79	4.64	20.43	0.110	With Dual Display (90°)

Note: This device was tested under all bandwidths, modulations and RB configurations and the worst case data are reported in the table above.

**- Measurement data: With wireless charging pad**

Channel Bandwidth (MHz)	Test Frequency (MHz)	Test Mode	RB Size/ Offset	Ant Pol (H/V)	Level(dBm) @ Ant Terminal	TX Ant Gain (dBi)	EIRP (dBm)	EIRP (W)	Note
20	1900	QPSK	1/0	H	17.15	4.69	21.84	0.153	-
		16QAM	1/0	H	16.53	4.69	21.22	0.132	-
		64QAM	1/0	H	15.39	4.69	20.08	0.102	-
15	1902.5	QPSK	1/0	H	16.78	4.68	21.46	0.140	-
		16QAM	1/0	H	15.93	4.68	20.61	0.115	-
		64QAM	1/0	H	15.12	4.68	19.80	0.095	-
10	1880	QPSK	1/25	H	17.46	4.67	22.13	0.163	-
		16QAM	1/25	H	16.78	4.67	21.45	0.140	-
		64QAM	1/25	H	15.88	4.67	20.55	0.114	-
5	1907.5	QPSK	1/12	H	17.43	4.65	22.08	0.161	-
		16QAM	1/12	H	16.61	4.65	21.26	0.134	-
		64QAM	1/12	H	15.62	4.65	20.27	0.106	-
3	1908.5	QPSK	1/7	H	17.15	4.65	21.80	0.151	-
		16QAM	1/7	H	16.46	4.65	21.11	0.129	-
		64QAM	1/7	H	15.66	4.65	20.31	0.107	-
1.4	1909.3	QPSK	1/2	H	16.66	4.64	21.30	0.135	-
		16QAM	1/2	H	15.99	4.64	20.63	0.116	-
		64QAM	1/2	H	14.96	4.64	19.60	0.091	-
		QPSK	1/2	V	14.09	4.64	18.73	0.075	With Dual Display (90°)

Note1: This device was tested under all bandwidths, modulations and RB configurations and the worst case data are reported in the table above.

## 7.6 UNDESIRABLE EMISSIONS (Radiated)

### 7.6.1 LTE Band 12, 17

- Measurement data: Without wireless charging pad

B.W (MHz)	Test Freq. (MHz)	RB Size/ Offset	Test Mode	Freq.(MHz)	Ant Pol (H/V)	Level(dBm) @ Ant Terminal	TX Ant Gain(dBd)	Result		Limit (dBc)	Note
								(dBm)	(dBc)		
10	704	1/49	QPSK	1416.93	V	-53.72	2.86	-50.86	70.52	32.66	-
				2125.06	V	-49.24	3.12	-46.12	65.78		-
			16QAM	1416.68	V	-53.43	2.86	-50.57	68.89	31.32	-
				2124.97	V	-50.47	3.11	-47.36	65.68		-
			64QAM	1416.77	V	-53.81	2.86	-50.95	67.96	30.01	-
				2125.06	V	-50.69	3.12	-47.57	64.58		-
	711	1/49	QPSK	1430.86	V	-51.67	3.00	-48.67	69.68	34.01	-
				2146.20	V	-49.22	3.20	-46.02	67.03		-
			16QAM	1430.90	V	-52.25	3.01	-49.24	68.54	32.30	-
				2146.23	V	-49.37	3.20	-46.17	65.47		-
			64QAM	1430.63	V	-51.85	3.00	-48.85	67.14	31.29	-
				2146.31	V	-48.59	3.20	-45.39	63.68		-
1.4	715.3	1/2	QPSK	1430.51	H	-51.02	3.00	-48.02	69.14	34.12	-
				2145.60	V	-49.10	3.20	-45.90	67.02		-
			16QAM	1430.26	H	-50.78	3.00	-47.78	67.36	32.58	-
				2145.42	V	-50.46	3.20	-47.26	66.84		-
			64QAM	1430.49	H	-50.99	3.00	-47.99	66.55	31.56	-
				2145.50	V	-49.66	3.20	-46.46	65.02		-
			QPSK	1430.53	V	-55.64	3.00	-52.64	72.72	33.08	With Dual Display (180°)
				2145.28	V	-52.29	3.20	-49.09	49.09		

Note 1: Limit Calculation =  $43 + 10\log_{10}(P[\text{Watts}])$

Note 2: This device was tested under all bandwidths, modulations and RB configurations and the worst case data are reported in the table above.

Note 3: The frequency spectrum is examined from 9 kHz to the 10th harmonic of the fundamental frequency of the transmitter. No other spurious and harmonic emissions were reported greater than listed emissions above table.



**- Measurement data: With wireless charging pad**

B.W (MHz)	Test Freq. (MHz)	RB Size/ Offset	Test Mode	Freq.(MHz)	Ant Pol (H/V)	Level(dBm) @ Ant Terminal	TX Ant Gain(dBd)	Result		Limit (dBc)	Note
								(dBm)	(dBc)		
10	711	1/49	QPSK	1431.32	H	-57.00	3.01	-53.99	72.56	31.57	-
			QPSK	2146.03	H	-50.79	3.20	-47.59	66.16		-
1.4	715.3	1/2	QPSK	1430.19	H	-57.70	3.00	-54.70	73.25	31.55	-
			QPSK	2145.89	H	-54.12	3.20	-50.92	69.47		-
			QPSK	1428.56	H	-58.60	2.98	-55.62	78.57	35.95	With Dual Display (180°)
			QPSK	2145.39	H	-54.64	3.20	-51.44	51.44		

Note 1: Limit Calculation =  $43 + 10\log_{10}(P[\text{Watts}])$

Note 2: This device was tested under all bandwidths, modulations and RB configurations and the worst case data are reported in the table above.

Note 3: The frequency spectrum is examined from 9 kHz to the 10th harmonic of the fundamental frequency of the transmitter. No other spurious and harmonic emissions were reported greater than listed emissions above table.

### 7.6.2 LTE Band 5

#### - Measurement data: Without wireless charging pad

B.W (MHz)	Test Freq. (MHz)	RB Size/ Offset	Test Mode	Freq.(MHz)	Ant Pol (H/V)	Level(dBm) @ Ant Terminal	TX Ant Gain(dBd)	Result		Limit (dBc)	Note
								(dBm)	(dBc)		
10	829	1/25	QPSK	1658.20	V	-50.93	3.85	-47.08	64.39	30.31	-
				2487.28	V	-39.70	3.81	-35.89	53.20		-
			16QAM	1658.52	V	-51.38	3.85	-47.53	63.38	28.85	-
				2487.21	V	-40.07	3.81	-36.26	52.11		-
			64QAM	1658.24	V	-51.38	3.85	-47.53	62.20	27.67	-
				2487.30	V	-39.75	3.81	-35.94	50.61		-
	836.5	1/25	QPSK	1673.24	V	-47.52	3.89	-43.63	63.02	32.39	-
				2509.73	V	-35.59	3.80	-31.79	51.18		-
			16QAM	1673.18	V	-49.34	3.89	-45.45	63.30	30.85	-
				2509.65	V	-36.84	3.80	-33.04	50.89		-
			64QAM	1673.15	V	-47.82	3.89	-43.93	60.37	29.44	-
				2509.75	V	-34.62	3.80	-30.82	47.26		-
	844	1/25	QPSK	1687.98	V	-49.68	3.94	-45.74	65.06	32.32	-
				2532.33	V	-35.63	3.75	-31.88	51.20		-
			16QAM	1688.20	V	-50.09	3.94	-46.15	64.08	30.93	-
				2532.21	V	-35.89	3.75	-32.14	50.07		-
			64QAM	1688.26	V	-50.32	3.94	-46.38	63.11	29.73	-
				2532.35	V	-35.99	3.75	-32.24	48.97		-
3	836.5	1/7	QPSK	1673.19	V	-47.84	3.89	-43.95	63.87	32.92	-
				2509.75	V	-34.92	3.80	-31.12	51.04		-
			16QAM	1672.84	V	-48.22	3.89	-44.33	62.71	31.38	-
				2509.32	V	-36.06	3.81	-32.25	50.63		-
			64QAM	1673.07	V	-49.77	3.89	-45.88	63.16	30.28	-
				2509.61	V	-38.03	3.81	-34.22	51.50		-
			QPSK	1671.45	V	-56.46	3.89	-52.57	71.45	31.88	With Dual Display (180°)
				2509.82	V	-42.07	3.80	-38.27	57.15		

Note 1: Limit Calculation =  $43 + 10\log_{10}(P[\text{Watts}])$

Note 2: This device was tested under all bandwidths, modulations and RB configurations and the worst case data are reported in the table above.

Note 3: The frequency spectrum is examined from 9 kHz to the 10th harmonic of the fundamental frequency of the transmitter. No other spurious and harmonic emissions were reported greater than listed emissions above table.

**- Measurement data: With wireless charging pad**

B.W (MHz)	Test Freq. (MHz)	RB Size/ Offset	Test Mode	Freq.(MHz)	Ant Pol (H/V)	Level(dBm) @ Ant Terminal	TX Ant Gain(dBd)	Result		Limit (dBc)	Note
								(dBm)	(dBc)		
10	836.5	1/25	QPSK	1673.02	H	-51.82	3.89	-47.93	68.01	33.08	-
				2509.81	H	-41.64	3.80	-37.84	57.92		-
3	836.5	1/2	QPSK	1672.99	H	-50.30	3.89	-46.41	66.36	32.95	-
				2509.38	H	-42.30	3.81	-38.49	58.44		-
		1/12	QPSK	1673.24	H	-57.18	3.89	-53.29	71.14	30.85	With Dual Display (180°)
				2509.67	H	-44.88	3.80	-41.08	41.08		

Note 1: Limit Calculation =  $43 + 10\log_{10}(P[\text{Watts}])$

Note 2: This device was tested under all bandwidths, modulations and RB configurations and the worst case data are reported in the table above.

Note 3: The frequency spectrum is examined from 9 kHz to the 10th harmonic of the fundamental frequency of the transmitter. No other spurious and harmonic emissions were reported greater than listed emissions above table.

### 7.6.3 LTE Band 4

#### - Measurement data: Without wireless charging pad

B.W (MHz)	Test Freq. (MHz)	RB Size/ Offset	Test Mode	Freq.(MHz)	Ant Pol (H/V)	Level(dBm) @ Ant Terminal	TX Ant Gain(dBi)	Result		Limit (dBc)	Note
								(dBm)	(dBc)		
20	1720	1/50	QPSK	3439.82	V	-52.62	8.05	-44.57	64.65	33.08	-
				5160.24	V	-43.05	10.28	-32.77	52.85		-
			16QAM	3440.02	V	-52.90	8.05	-44.85	64.72	32.87	-
				5160.33	V	-43.02	10.28	-32.74	52.61		-
			64QAM	3440.24	V	-53.10	8.05	-45.05	64.11	32.06	-
				5160.25	V	-44.71	10.28	-34.43	53.49		-
	1732.5	1/50	QPSK	3464.84	V	-53.94	8.12	-45.82	66.20	33.38	-
				5197.69	V	-42.15	10.34	-31.81	52.19		-
			16QAM	3465.19	V	-53.84	8.12	-45.72	65.57	32.85	-
				5197.81	V	-41.35	10.34	-31.01	50.86		-
			64QAM	3465.19	V	-54.73	8.12	-46.61	65.57	31.96	-
				5197.56	V	-40.99	10.34	-30.65	49.61		-
	1745	1/50	QPSK	3490.07	V	-54.94	8.18	-46.76	67.63	33.87	-
				5235.32	V	-40.35	10.33	-30.02	50.89		-
			16QAM	3490.26	V	-54.47	8.18	-46.29	66.57	33.28	-
				5235.32	V	-39.45	10.33	-29.12	49.40		-
			64QAM	3490.34	V	-54.88	8.18	-46.70	65.77	32.07	-
				5235.22	V	-40.32	10.33	-29.99	49.06		-
15	1747.5	1/36	QPSK	3494.41	V	-55.08	8.19	-46.89	68.17	34.28	-
				5241.90	V	-40.49	10.32	-30.17	51.45		-
			16QAM	3497.00	V	-55.30	8.19	-47.11	67.47	33.36	-
				5242.10	V	-39.23	10.32	-28.91	49.27		-
			64QAM	3495.41	V	-54.74	8.19	-46.55	66.13	32.58	-
				5241.93	V	-39.11	10.32	-28.79	48.37		-
			QPSK	3439.37	V	-55.06	8.18	-46.88	67.41	33.53	With Dual Display (180°)
				5241.97	V	-48.95	10.32	-38.63	59.16		

Note 1: Limit Calculation =  $43 + 10\log_{10}(P[\text{Watts}])$

Note 2: This device was tested under all bandwidths, modulations and RB configurations and the worst case data are reported in the table above.

Note 3: The frequency spectrum is examined from 9 kHz to the 10th harmonic of the fundamental frequency of the transmitter. No other spurious and harmonic emissions were reported greater than listed emissions above table.

**- Measurement data: With wireless charging pad**

B.W (MHz)	Test Freq. (MHz)	RB Size/ Offset	Test Mode	Freq.(MHz)	Ant Pol (H/V)	Level(dBm) @ Ant Terminal	TX Ant Gain(dBi)	Result		Limit (dBc)	Note
								(dBm)	(dBc)		
20	1745	1/50	QPSK	3489.77	H	-55.92	8.18	-47.74	69.29	34.55	-
				5235.30	H	-51.36	10.33	-41.03	62.58		-
15	1747.5	1/36	QPSK	3493.39	H	-55.79	8.18	-47.61	69.25	34.64	
				5242.15	H	-50.46	10.32	-40.14	61.78		
				3492.95	H	-56.30	8.18	-48.12	67.84	32.72	With Dual Display (180°)
				5241.78	H	-49.26	10.32	-38.94	58.66		

Note 1: Limit Calculation =  $43 + 10\log_{10}(P[\text{Watts}])$

Note 2: This device was tested under all bandwidths, modulations and RB configurations and the worst case data are reported in the table above.

Note 3: The frequency spectrum is examined from 9 kHz to the 10th harmonic of the fundamental frequency of the transmitter. No other spurious and harmonic emissions were reported greater than listed emissions above table.

### 7.6.4 LTE Band 2

#### - Measurement data: Without wireless charging pad

B.W (MHz)	Test Freq. (MHz)	RB Size/ Offset	Test Mode	Freq.(MHz)	Ant Pol (H/V)	Level(dBm) @ Ant Terminal	TX Ant Gain(dBi)	Result		Limit (dBc)	Note
								(dBm)	(dBc)		
20	1860	1/0	QPSK	3702.20	V	-53.47	8.38	-45.09	64.62	32.53	-
				5553.24	V	-42.73	10.42	-32.31	51.84		-
			16QAM	3704.03	V	-53.93	8.38	-45.55	64.42	31.87	-
				5553.53	V	-42.09	10.42	-31.67	50.54		-
			64QAM	3702.10	V	-52.89	8.38	-44.51	62.40	30.89	-
				5553.44	V	-41.29	10.42	-30.87	48.76		-
	1880	1/0	QPSK	3742.36	V	-54.25	8.40	-45.85	65.24	32.39	-
				5613.43	V	-43.47	10.60	-32.87	52.26		-
			16QAM	3742.31	V	-54.77	8.40	-46.37	65.21	31.84	-
				5613.19	V	-42.46	10.60	-31.86	50.70		-
			64QAM	3741.89	V	-54.24	8.40	-45.84	63.56	30.72	-
				5613.15	V	-41.49	10.60	-30.89	48.61		-
	1900	1/0	QPSK	3782.43	V	-54.05	8.28	-45.77	66.75	33.98	-
				5673.30	V	-44.04	10.70	-33.34	54.32		-
			16QAM	3781.69	V	-54.89	8.29	-46.60	66.89	33.29	-
				5673.26	V	-42.82	10.70	-32.12	52.41		-
			64QAM	3781.84	V	-54.49	8.29	-46.20	65.80	32.60	-
				5673.19	V	-41.38	10.70	-30.68	50.28		-
1.4	1909.3	1/2	QPSK	3818.27	V	-54.91	8.22	-46.69	67.78	34.09	-
				5727.47	V	-44.54	10.72	-33.82	54.91		-
			16QAM	3817.54	V	-54.47	8.22	-46.25	66.56	33.31	-
				5727.66	V	-44.09	10.72	-33.37	53.68		-
			64QAM	3818.17	V	-55.36	8.22	-47.14	66.40	32.26	-
				5727.70	V	-43.89	10.72	-33.17	52.43		-
			QPSK	3819.84	V	-55.00	8.22	-46.78	67.21	33.43	With Dual Display (180°)
				5727.54	V	-40.56	10.72	-29.84	50.27		

Note 1: Limit Calculation =  $43 + 10\log_{10}(P[\text{Watts}])$

Note 2: This device was tested under all bandwidths, modulations and RB configurations and the worst case data are reported in the table above.

Note 3: The frequency spectrum is examined from 9 kHz to the 10th harmonic of the fundamental frequency of the transmitter. No other spurious and harmonic emissions were reported greater than listed emissions above table.

**- Measurement data: With wireless charging pad**

B.W (MHz)	Test Freq. (MHz)	RB Size/ Offset	Test Mode	Freq.(MHz)	Ant Pol (H/V)	Level(dBm) @ Ant Terminal	TX Ant Gain(dBi)	Result		Limit (dBc)	Note
								(dBm)	(dBc)		
20	1900	1/0	QPSK	3781.51	V	-54.45	8.29	-46.16	68.00	34.84	-
				5673.18	V	-44.45	10.70	-33.75	55.59		-
1.4	1909.3	1/2	QPSK	3819.02	V	-53.70	8.22	-45.48	66.78	34.30	-
				5727.70	V	-41.90	10.72	-31.18	52.48		-
			QPSK	3818.59	V	-55.74	8.22	-47.52	66.25	31.73	With Dual Display (180°)
				5727.39	V	-46.17	10.72	-35.45	54.18		

Note 1: Limit Calculation =  $43 + 10\log_{10}(P[\text{Watts}])$

Note 2: This device was tested under all bandwidths, modulations and RB configurations and the worst case data are reported in the table above.

Note 3: The frequency spectrum is examined from 9 kHz to the 10th harmonic of the fundamental frequency of the transmitter. No other spurious and harmonic emissions were reported greater than listed emissions above table.

## 7.7 FREQUENCY STABILITY

### 7.7.1 LTE Band 12, 17

OPERATING FREQUENCY : 707.5 MHz  
 REFERENCE VOLTAGE : 3.87 VDC  
 LIMIT : The frequency stability shall be sufficient to ensure that the fundamental emission stays within the authorized frequency block.

VOLTAGE (%)	POWER (V DC)	TEMP (°C)	FREQUENCY (Hz)	FREQ.Dev (Hz)	Deviation	
					(ppm)	(%)
100%	3.87	+20(Ref)	707,500,007	7	0.0099	0.000000989
100%		-30	707,499,997	-3	-0.0042	-0.000000424
100%		-20	707,499,994	-6	-0.0085	-0.000000848
100%		-10	707,500,001	1	0.0014	0.000000141
100%		0	707,499,997	-3	-0.0042	-0.000000424
100%		+10	707,499,992	-8	-0.0113	-0.000001131
100%		+20	707,500,007	7	0.0099	0.000000989
100%		+30	707,499,999	-1	-0.0014	-0.000000141
100%		+40	707,500,006	6	0.0085	0.000000848
100%		+50	707,500,011	11	0.0155	0.000001555
11450%	4.45	+20	707,500,004	4	0.0057	0.000000565
BATT.ENDPOINT	2.55	+20	707,499,998	-2	-0.0028	-0.000000283

**Note 1:** Based on the results of the frequency stability test at the center channel the frequency deviation results measured are very small. As such it is determined that the channels at the band edge would remain inband when the maximum measured frequency deviation noted during the frequency stability tests is applied. Therefore the device is determined to remain operating in band over the temperature and voltage range as tested.



**7.8.2 LTE Band 5**

OPERATING FREQUENCY : 836.5 MHz  
 REFERENCE VOLTAGE : 3.87 VDC  
 DEVIATION LIMIT : ± 0.00025 % or 2.5 ppm

VOLTAGE (%)	POWER (V DC)	TEMP (°C)	FREQUENCY (Hz)	FREQ.Dev (Hz)	Deviation	
					(ppm)	(%)
100%	3.87	+20(Ref)	836,499,993	-7	-0.0084	-0.000000837
100%		-30	836,499,997	-3	-0.0036	-0.000000359
100%		-20	836,500,005	5	0.0060	0.000000598
100%		-10	836,499,999	-1	-0.0012	-0.000000120
100%		0	836,500,005	5	0.0060	0.000000598
100%		+10	836,499,994	-6	-0.0072	-0.000000717
100%		+20	836,499,993	-7	-0.0084	-0.000000837
100%		+30	836,499,989	-11	-0.0132	-0.000001315
100%		+40	836,499,991	-9	-0.0108	-0.000001076
100%		+50	836,500,002	2	0.0024	0.000000239
115%		4.45	+20	836,499,995	-5	-0.0060
BATT.ENDPOINT	2.55	+20	836,500,002	2	0.0024	0.000000239

**Note.** Based on the results of the frequency stability test at the center channel the frequency deviation results measured are very small. as such it is determined that the channels at the band edge would remain inband when the maximum measured frequency deviation noted during the frequency stability tests is applied. therefore the device is determined to remain operating in band over the temperature and voltage range as tested.

### 7.7.3 LTE Band 4

OPERATING FREQUENCY : 1732.5 MHz  
 REFERENCE VOLTAGE : 3.87 VDC  
 LIMIT : The frequency stability shall be sufficient to ensure that the fundamental emission stays within the authorized frequency block.

VOLTAGE (%)	POWER (V DC)	TEMP (°C)	FREQUENCY (Hz)	FREQ.Dev (Hz)	Deviation	
					(ppm)	(%)
100%	3.87	+20(Ref)	1,732,500,006	6	0.0035	0.000000346
100%		-30	1,732,499,995	-5	-0.0029	-0.000000289
100%		-20	1,732,500,003	3	0.0017	0.000000173
100%		-10	1,732,500,006	6	0.0035	0.000000346
100%		0	1,732,499,995	-5	-0.0029	-0.000000289
100%		+10	1,732,500,001	1	0.0006	0.000000058
100%		+20	1,732,500,006	6	0.0035	0.000000346
100%		+30	1,732,499,997	-3	-0.0017	-0.000000173
100%		+40	1,732,500,008	8	0.0046	0.000000462
100%		+50	1,732,500,011	11	0.0063	0.000000635
115%		4.45	+20	1,732,499,998	-2	-0.0012
BATT.ENDPOINT	2.55	+20	1,732,500,006	6	0.0035	0.000000346

**Note 1:** Based on the results of the frequency stability test at the center channel the frequency deviation results measured are very small. As such it is determined that the channels at the band edge would remain inband when the maximum measured frequency deviation noted during the frequency stability tests is applied. Therefore the device is determined to remain operating in band over the temperature and voltage range as tested.

**7.7.4 LTE Band 2**

OPERATING FREQUENCY : 1880 MHz  
 REFERENCE VOLTAGE : 3.87 VDC  
 LIMIT : The frequency stability shall be sufficient to ensure that the fundamental emission stays within the authorized frequency block.

VOLTAGE (%)	POWER (V DC)	TEMP (°C)	FREQUENCY (Hz)	FREQ.Dev (Hz)	Deviation	
					(ppm)	(%)
100%	3.87	+20(Ref)	1,880,000,008	8	0.0043	0.000000426
100%		-30	1,879,999,997	-3	-0.0016	-0.000000160
100%		-20	1,879,999,991	-9	-0.0048	-0.000000479
100%		-10	1,880,000,004	4	0.0021	0.000000213
100%		0	1,879,999,998	-2	-0.0011	-0.000000106
100%		+10	1,880,000,003	3	0.0016	0.000000160
100%		+20	1,880,000,008	8	0.0043	0.000000426
100%		+30	1,879,999,998	-2	-0.0011	-0.000000106
100%		+40	1,880,000,006	6	0.0032	0.000000319
100%		+50	1,880,000,009	9	0.0048	0.000000479
115%		4.45	+20	1,879,999,999	-1	-0.0005
BATT.ENDPOINT	2.55	+20	1,880,000,003	3	0.0016	0.000000160

**Note 1:** Based on the results of the frequency stability test at the center channel the frequency deviation results measured are very small. As such it is determined that the channels at the band edge would remain inband when the maximum measured frequency deviation noted during the frequency stability tests is applied. Therefore the device is determined to remain operating in band over the temperature and voltage range as tested.

## 8. TEST PLOTS

Note: All bandwidths, RB configurations, and modulations were investigated.  
The worst case test results are reported.

### 8.1 OCCUPIED BANDWIDTH

#### 8.1.1 LTE Band 12, 17

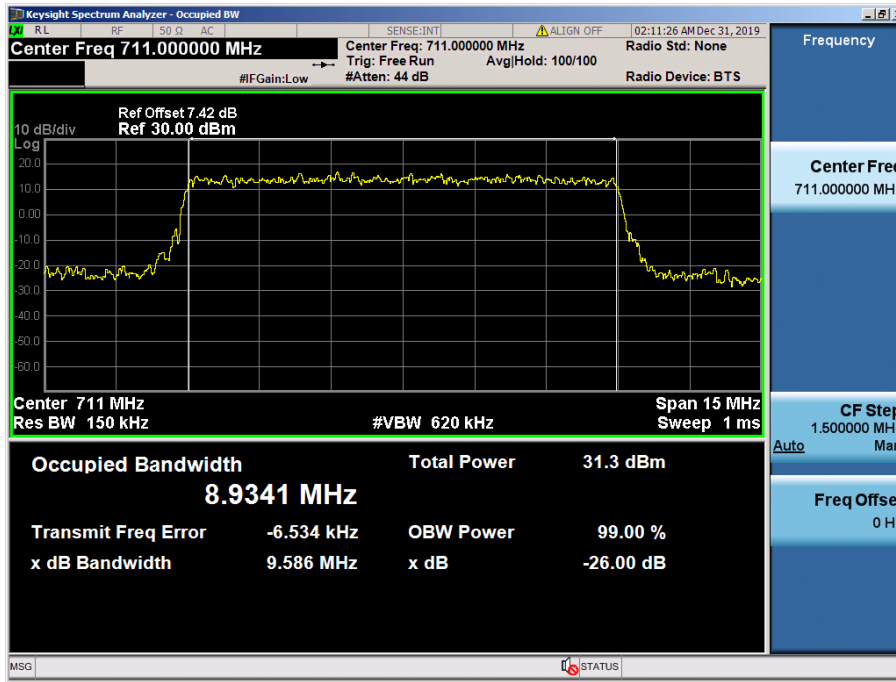

LTE Band 12, 17 / 10 MHz / QPSK - RB Size 50

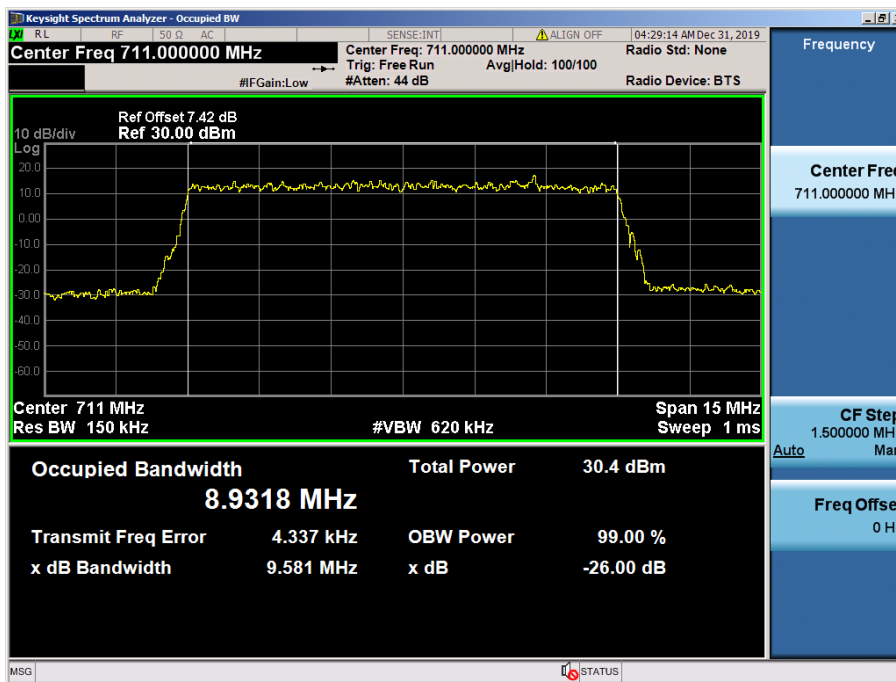

LTE Band 12, 17 / 10 MHz / 16QAM - RB Size 50

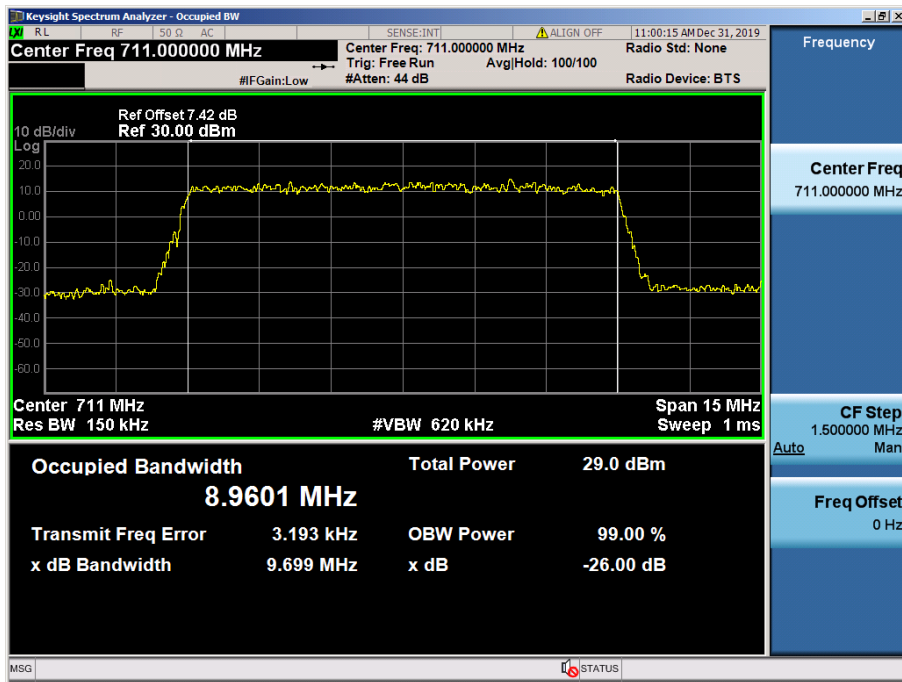

LTE Band 12, 17 / 10 MHz / 64QAM- RB Size 50

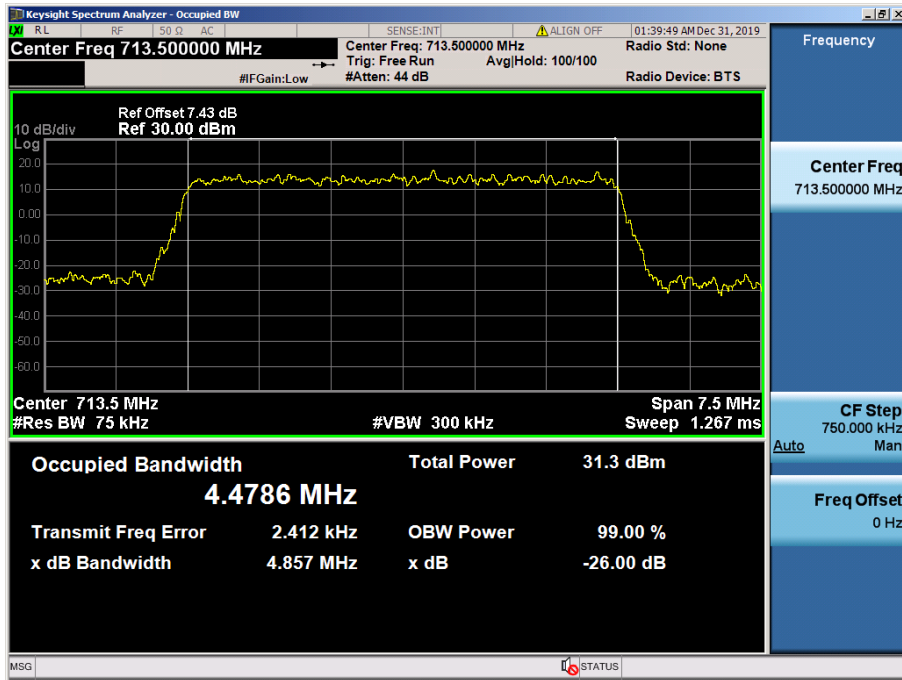

LTE Band 12, 17 / 5 MHz / QPSK - RB Size 25

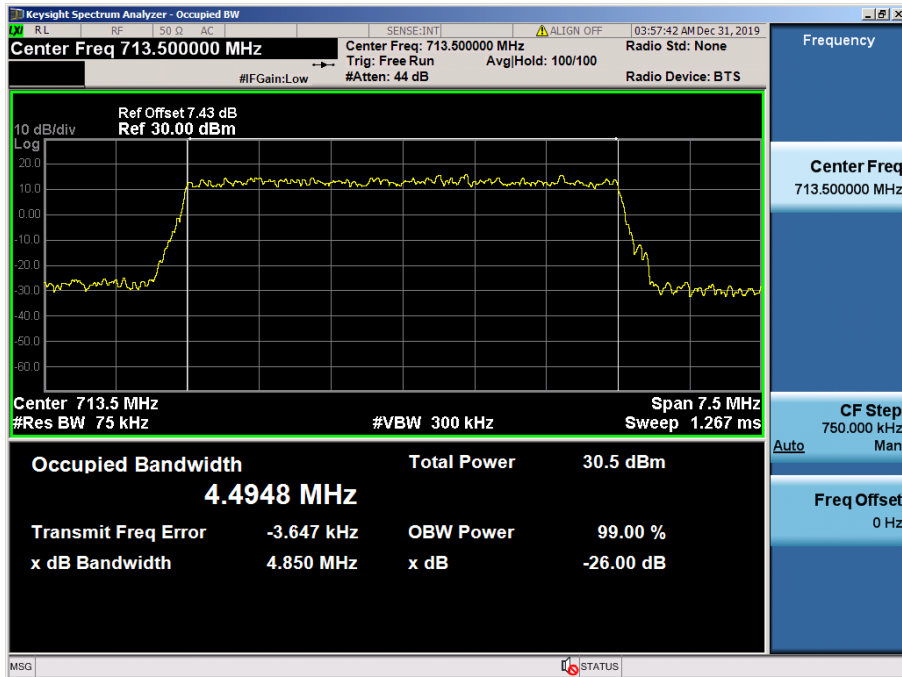

LTE Band 12, 17 / 5 MHz / 16QAM - RB Size 25

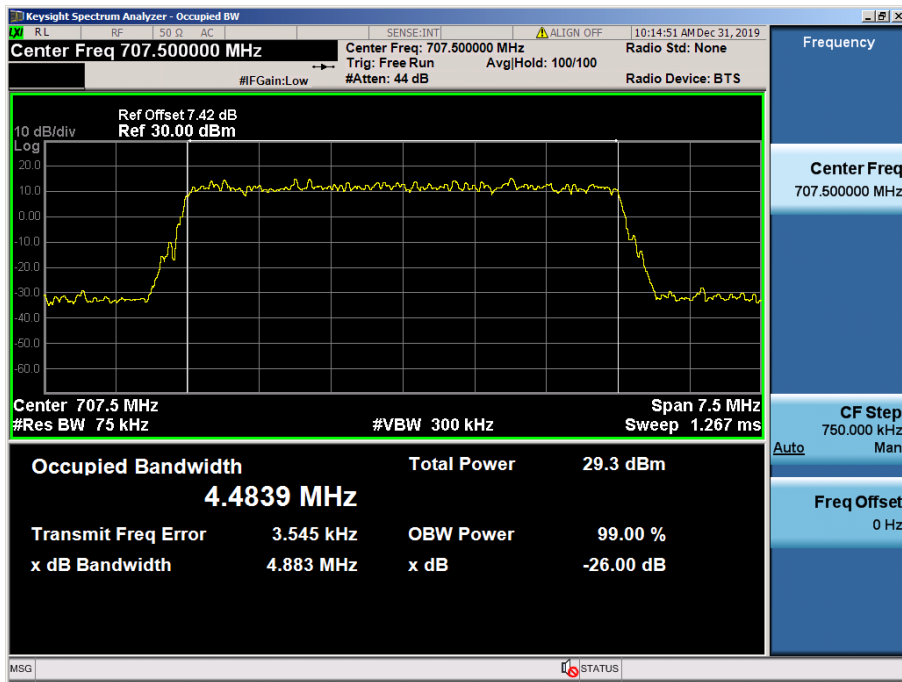

LTE Band 12, 17 / 5 MHz / 64QAM - RB Size 25

8.1.2 LTE Band 12

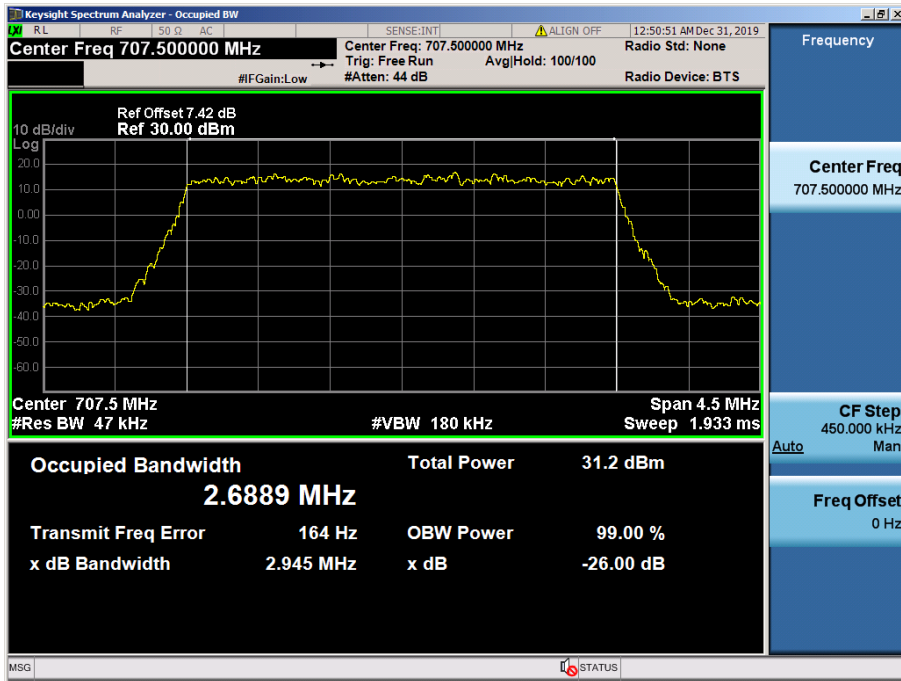

LTE Band 12 / 3 MHz / QPSK - RB Size 15

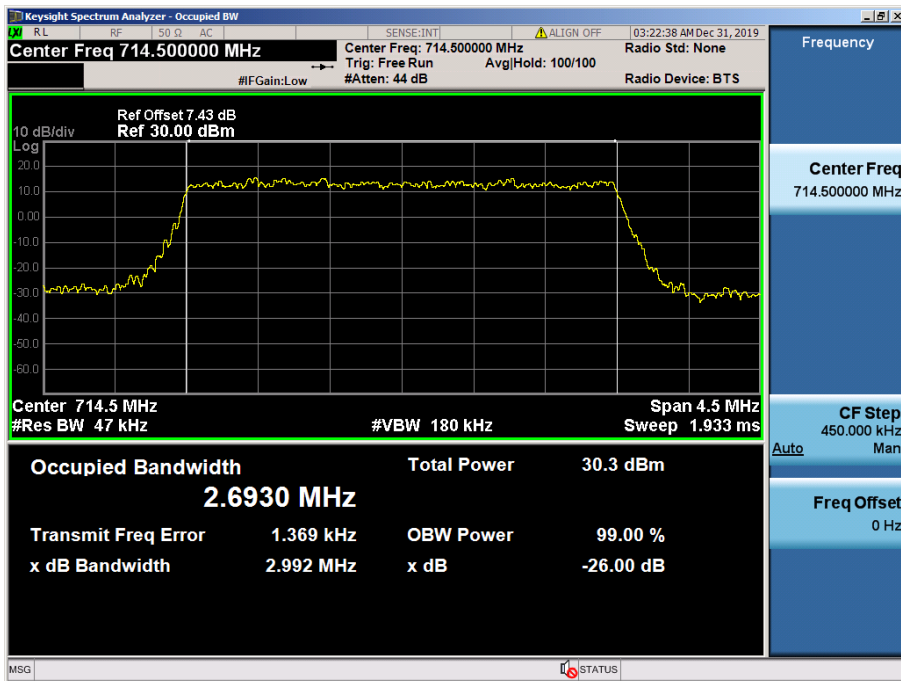

LTE Band 12 / 3 MHz / 16QAM - RB Size 15



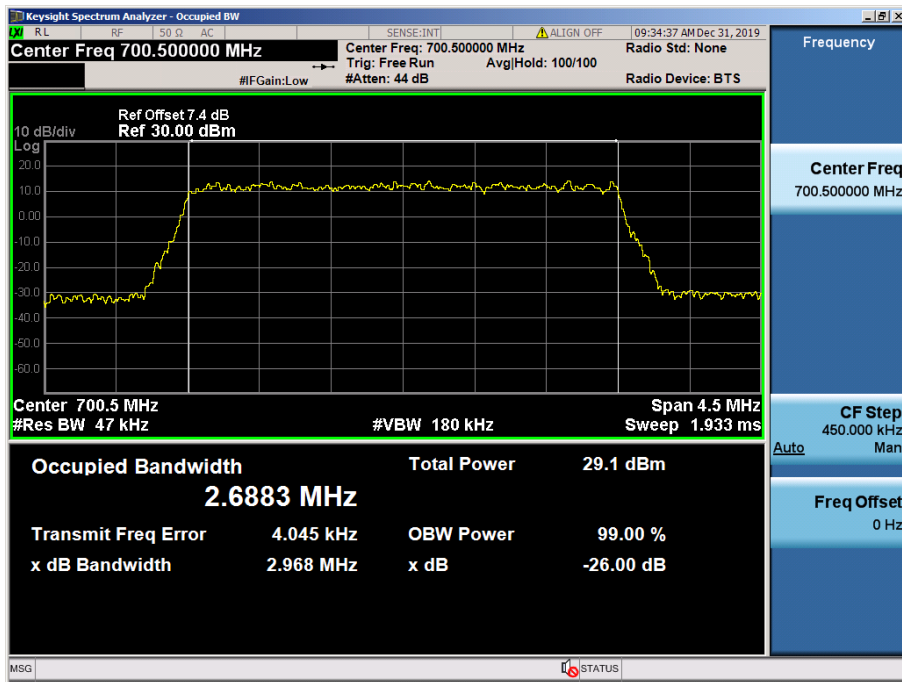

LTE Band 12 / 3 MHz / 64QAM - RB Size 15

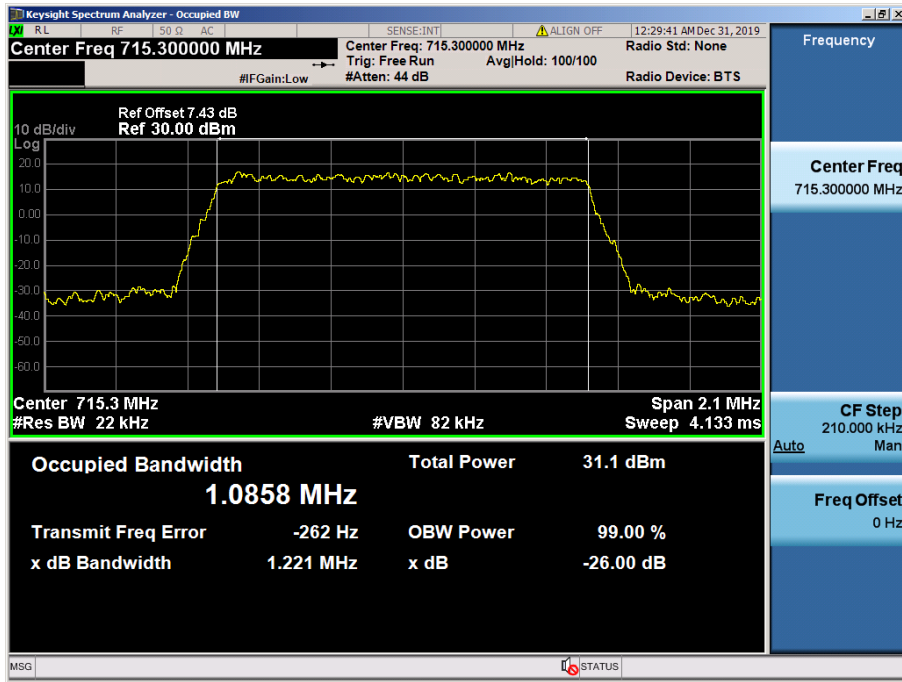

LTE Band 12 / 1.4 MHz / QPSK - RB Size 6

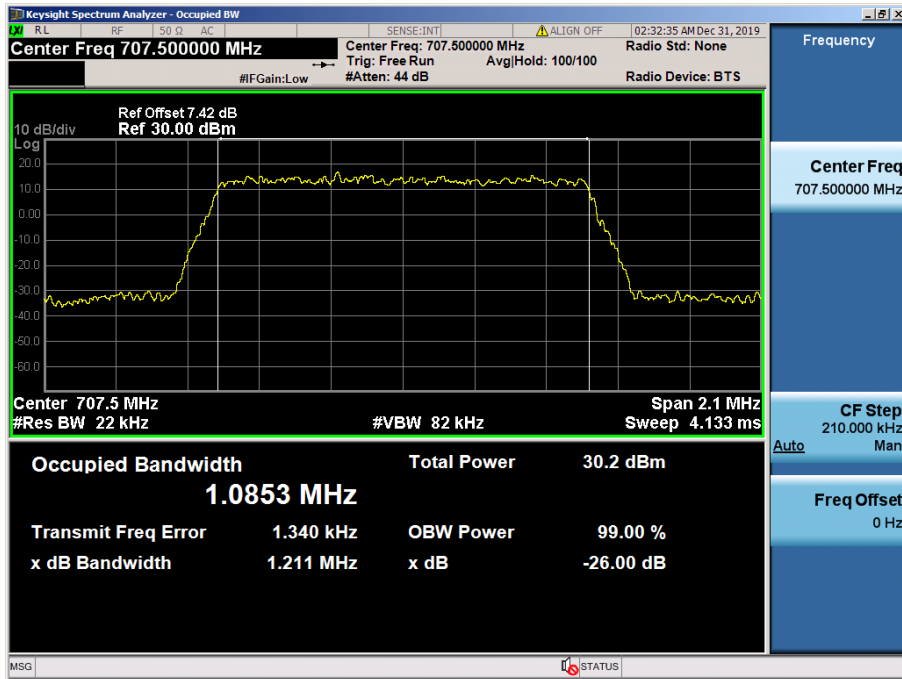

LTE Band 12 / 1.4 MHz / 16QAM - RB Size 6

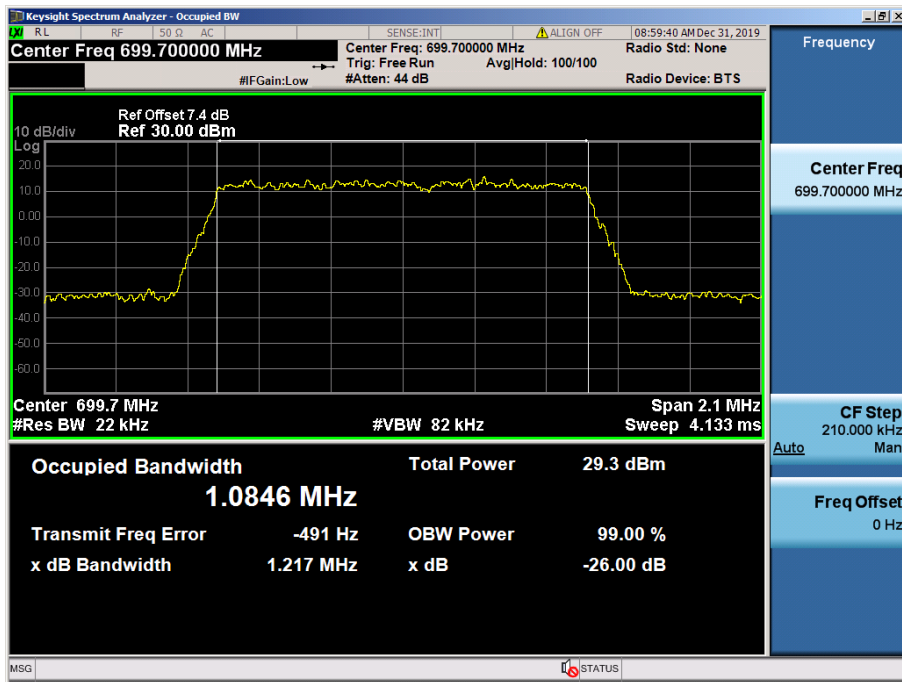

LTE Band 12 / 1.4 MHz / 64QAM - RB Size 6

8.1.3 LTE Band 5

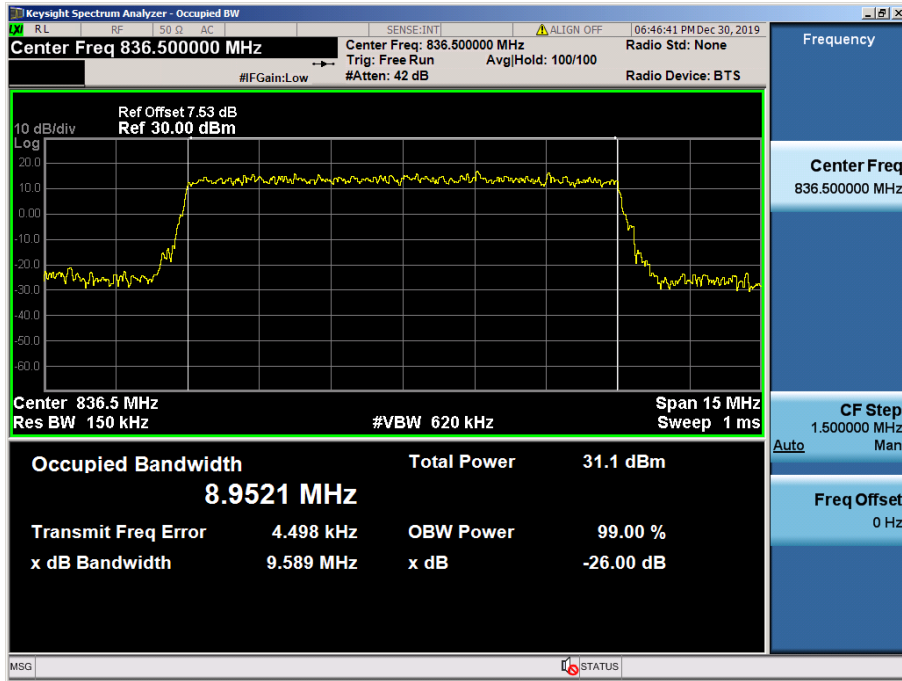

LTE Band 5 / 10 MHz / QPSK - RB Size 50

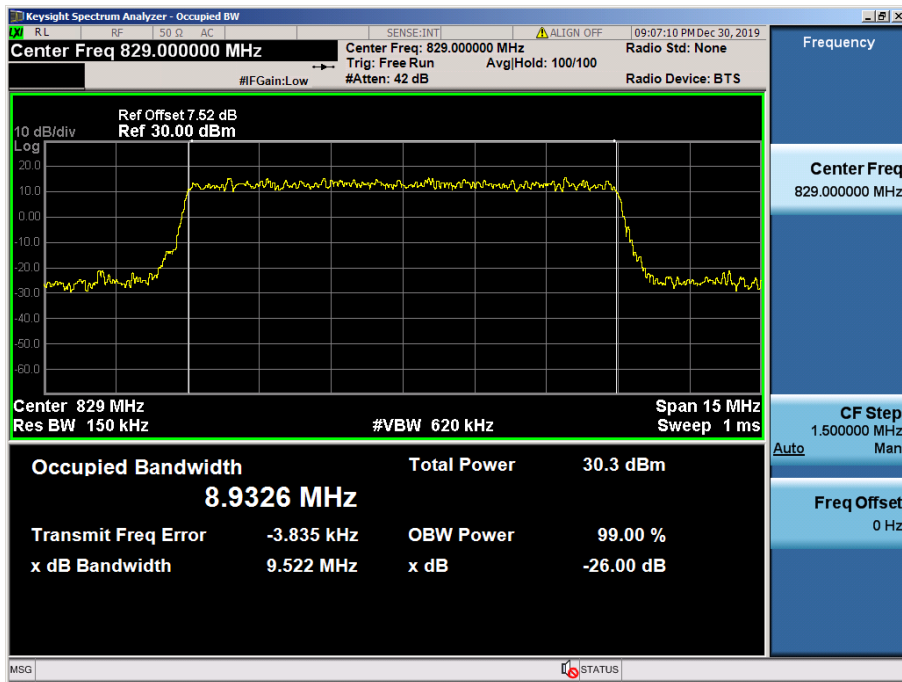

LTE Band 5 / 10 MHz / 16QAM - RB Size 50

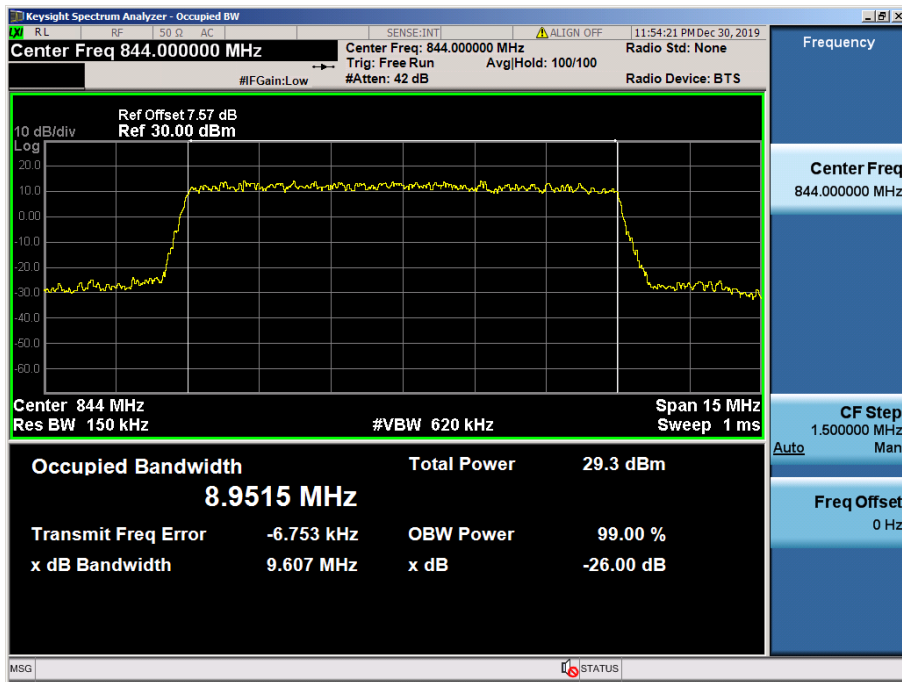

LTE Band 5 / 10 MHz / 64QAM - RB Size 50

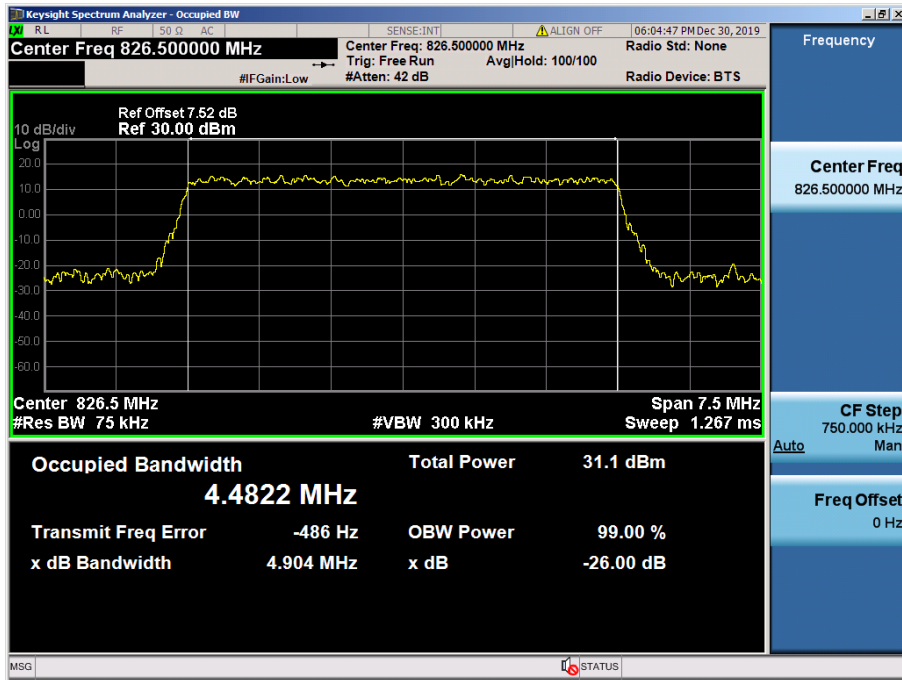

LTE Band 5 / 5 MHz / QPSK - RB Size 25

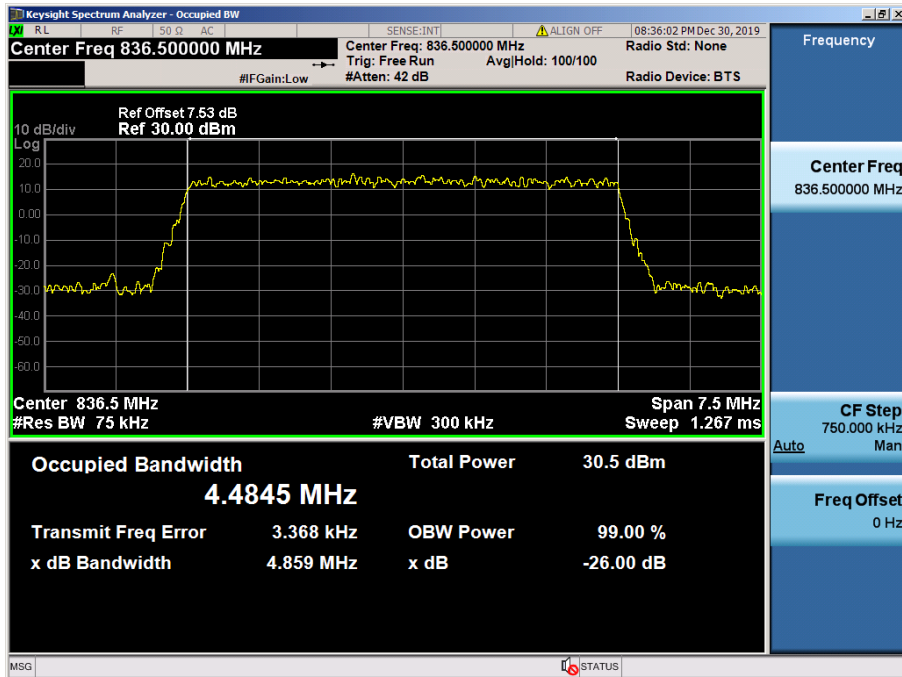

LTE Band 5 / 5 MHz / 16QAM - RB Size 25

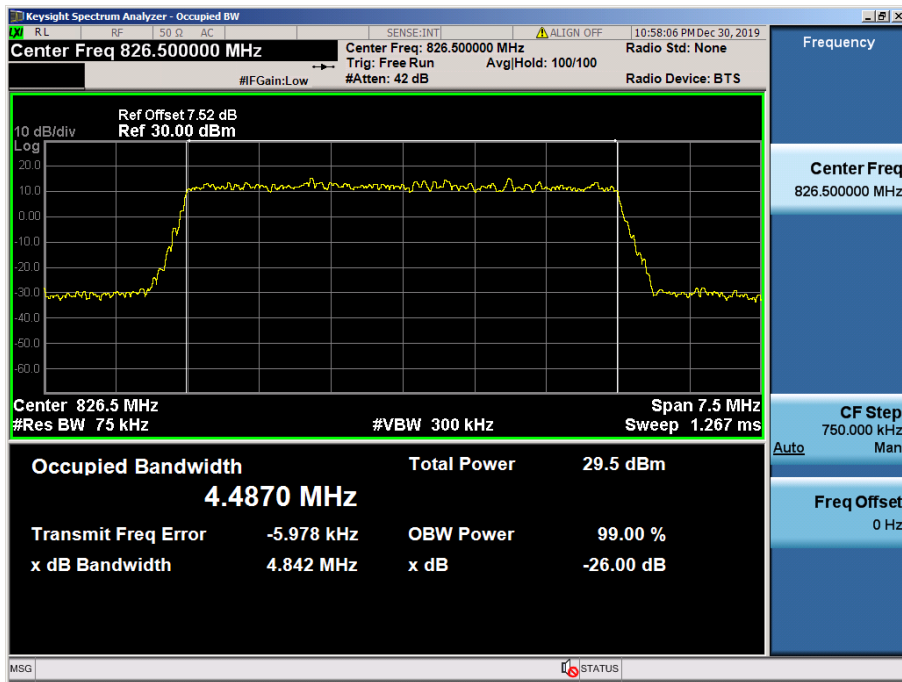

LTE Band 5 / 5 MHz / 64QAM - RB Size 25

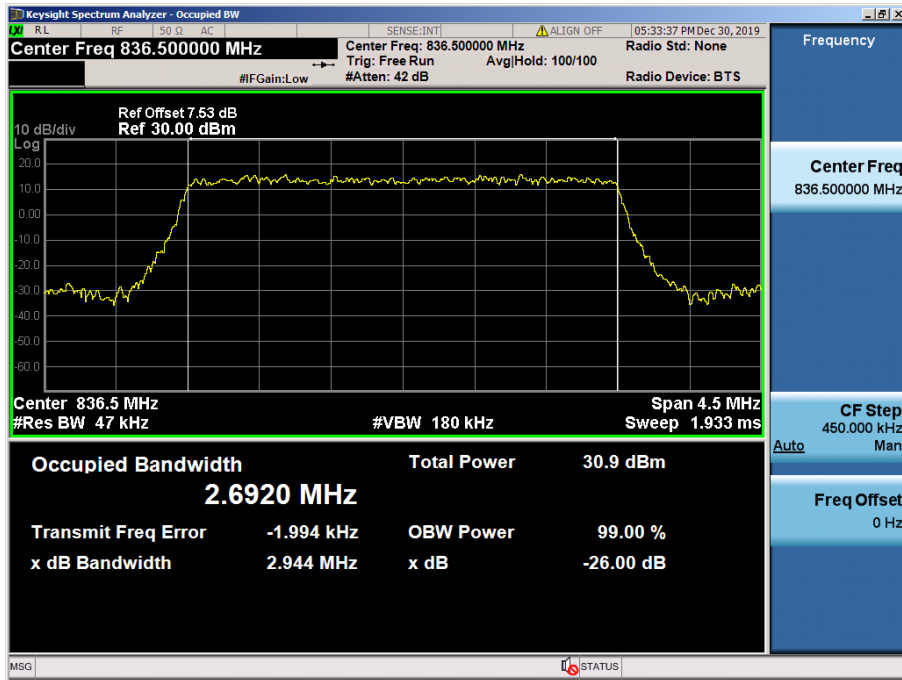

LTE Band 5 / 3 MHz / QPSK - RB Size 15

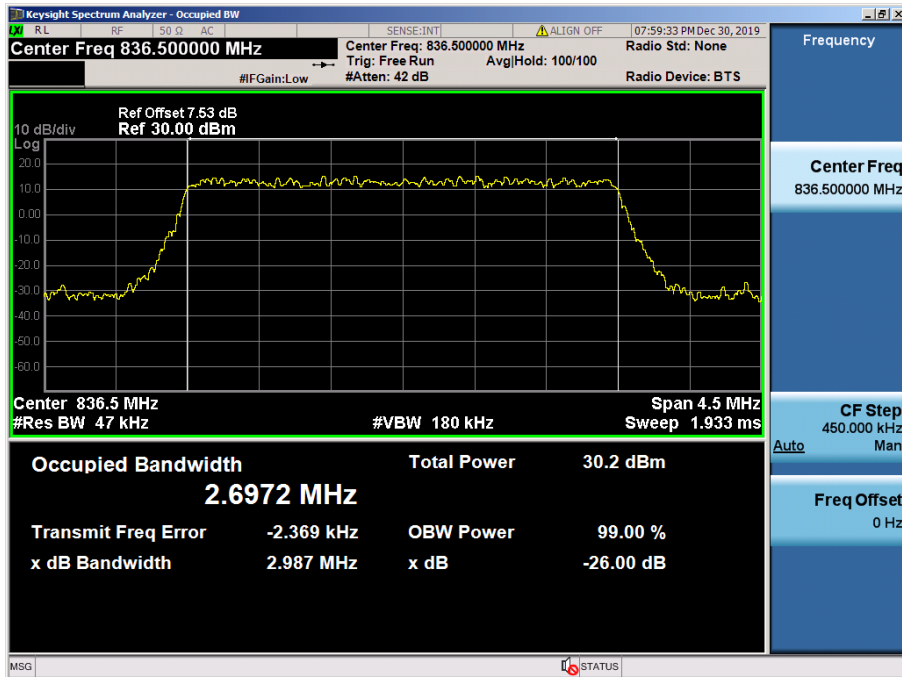

LTE Band 5 / 3 MHz / 16QAM - RB Size 15



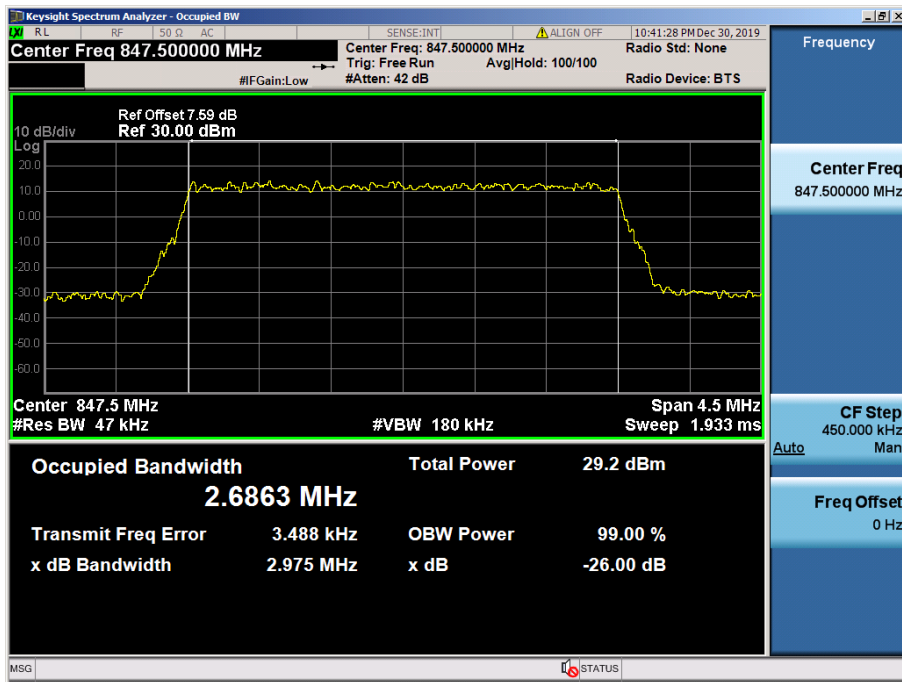

LTE Band 5 / 3 MHz / 64QAM - RB Size 15

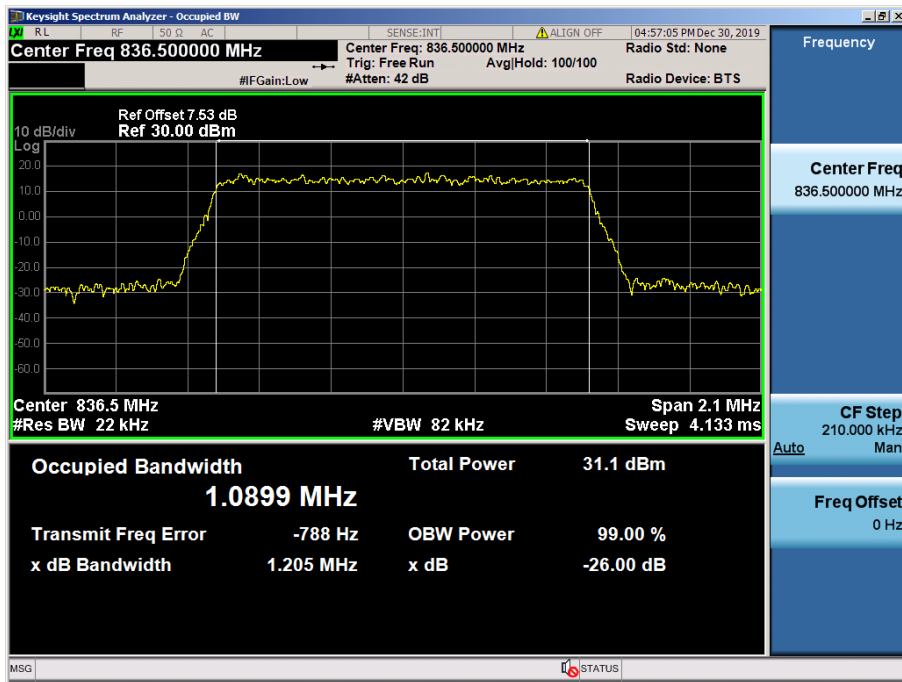

LTE Band 5 / 1.4 MHz / QPSK - RB Size 6

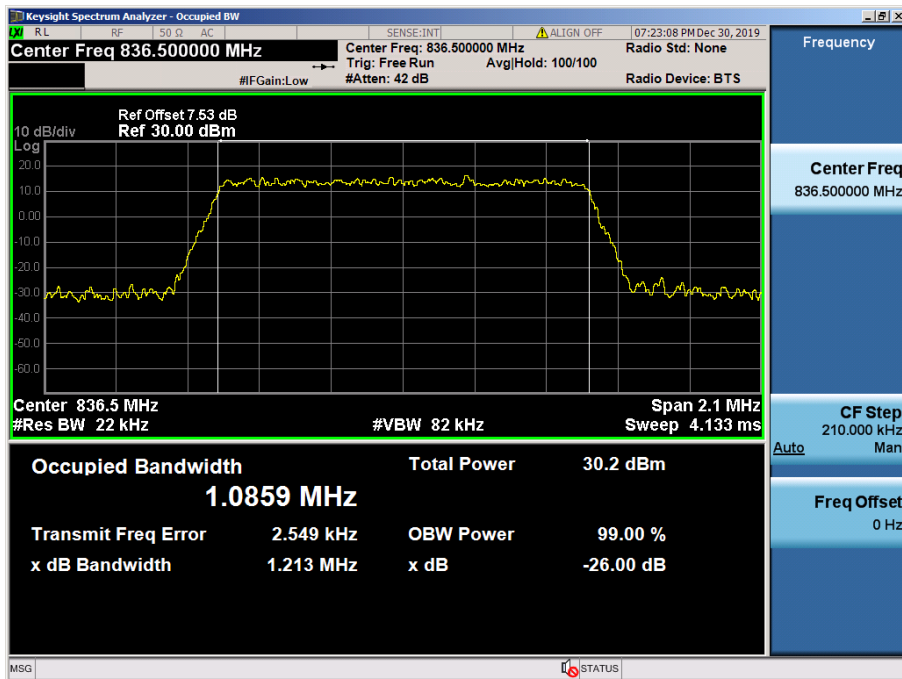

LTE Band 5 / 1.4 MHz / 16QAM - RB Size 6

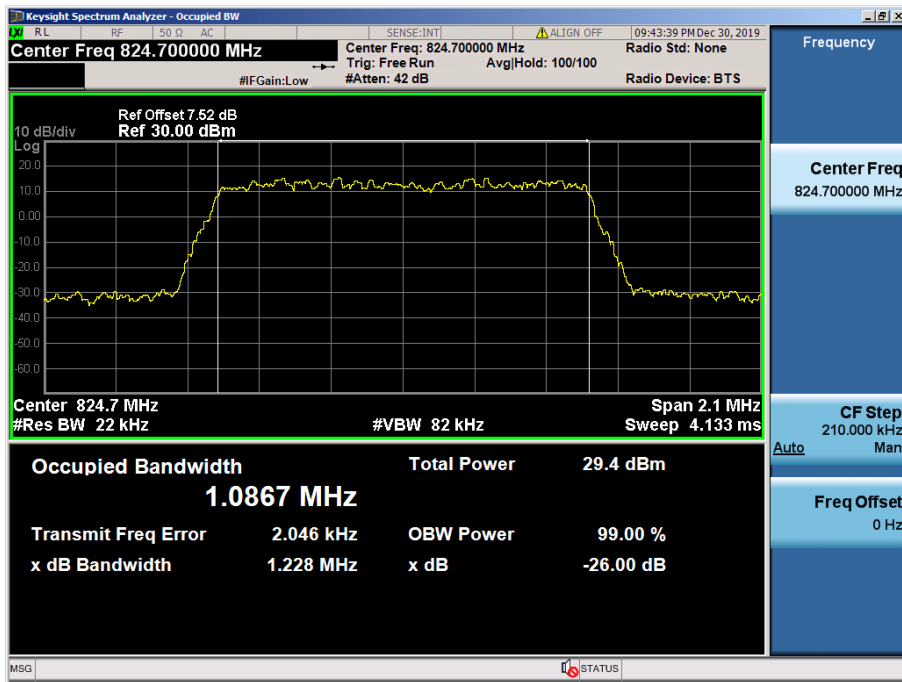

LTE Band 5 / 1.4 MHz / 64QAM - RB Size 6

8.1.3 LTE Band 4

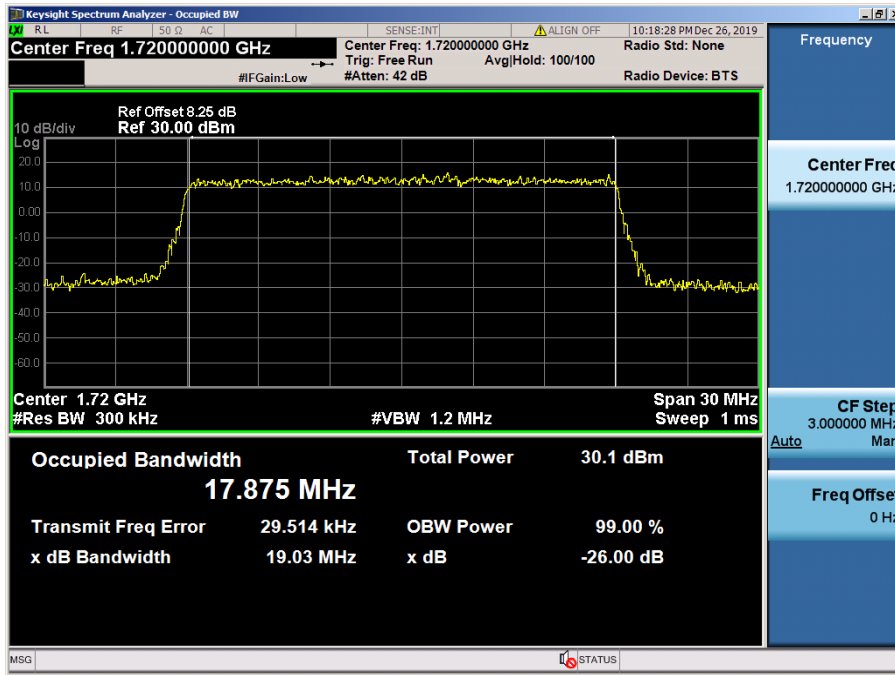

LTE Band 4 / 20 MHz / QPSK - RB Size 100

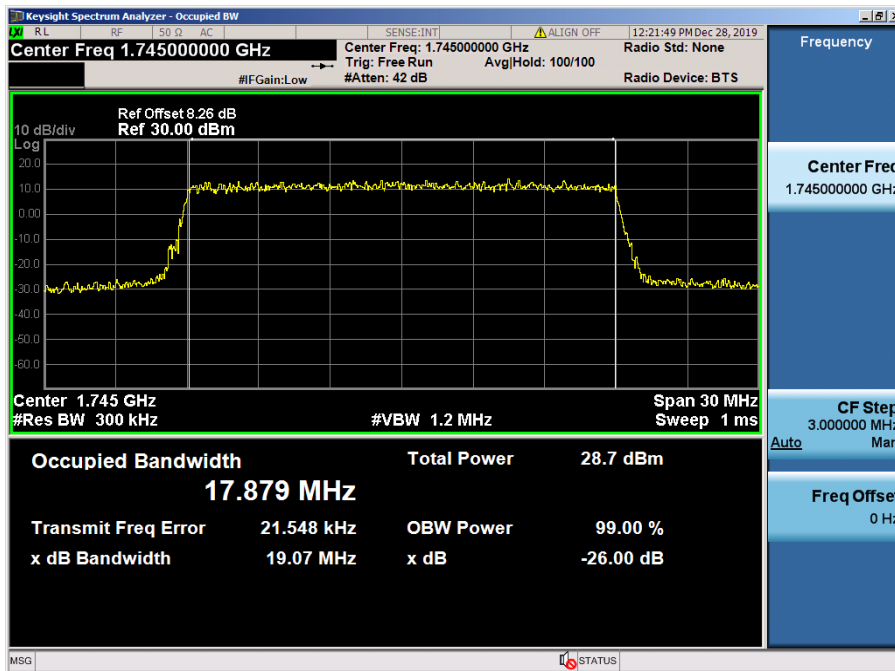

LTE Band 4 / 20 MHz / 16QAM - RB Size 100

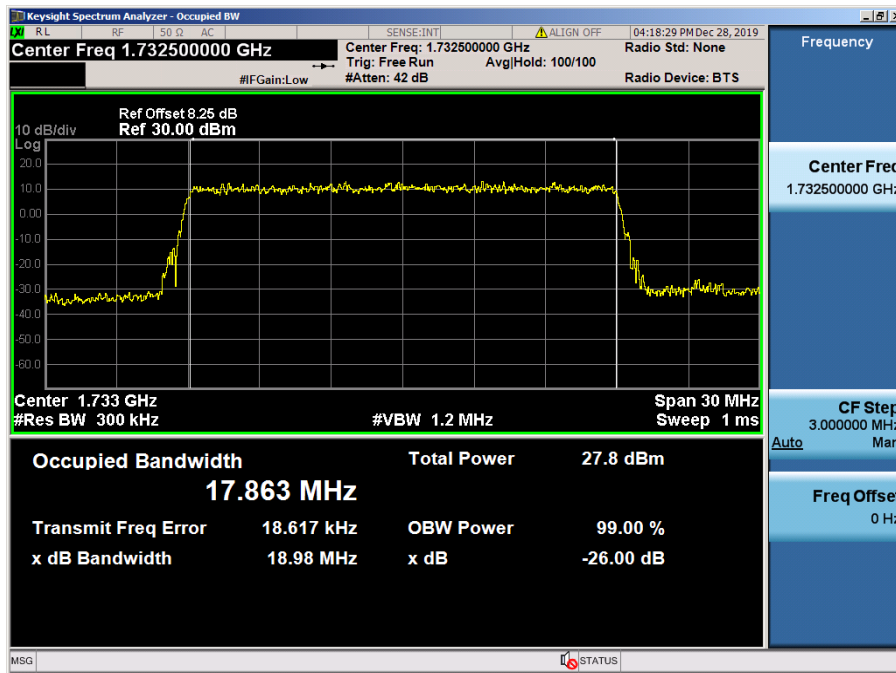

LTE Band 4 / 20 MHz / 64QAM - RB Size 100

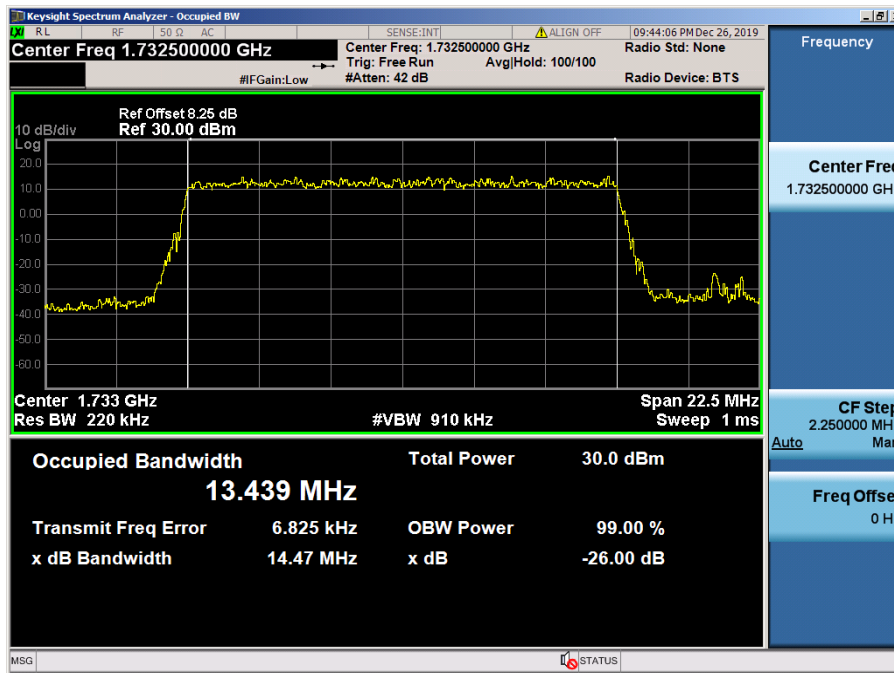

LTE Band 4 / 15 MHz / QPSK - RB Size 75

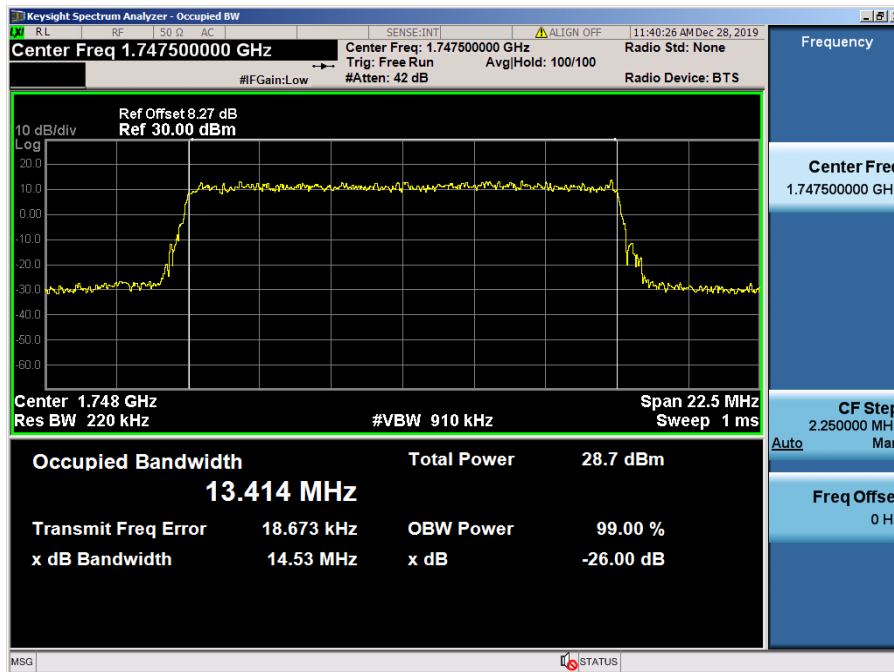

LTE Band 4 / 15 MHz / 16QAM - RB Size 75

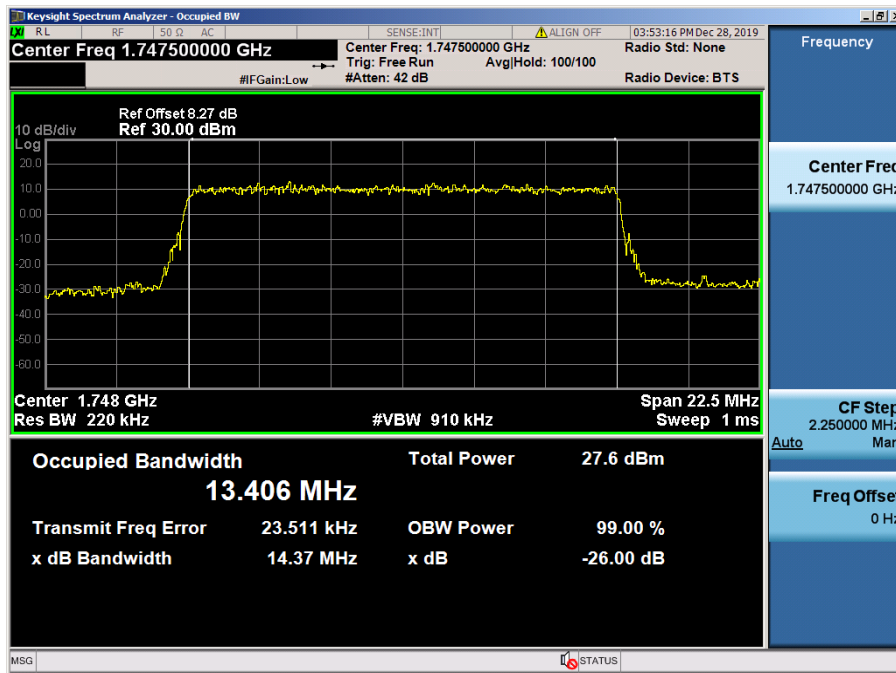

LTE Band 4 / 15 MHz / 64QAM - RB Size 75

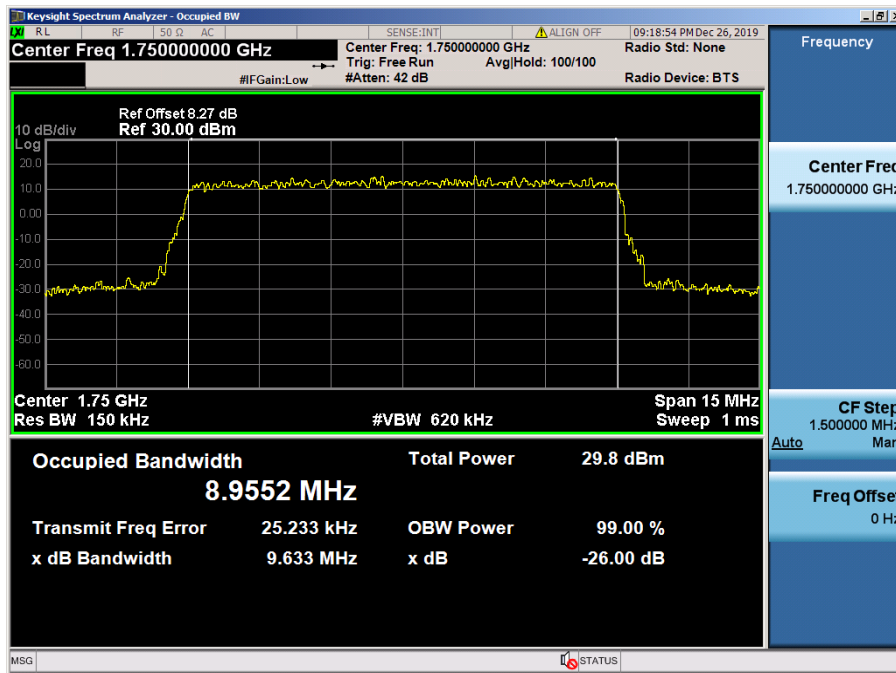

LTE Band 4 / 10 MHz / QPSK - RB Size 50

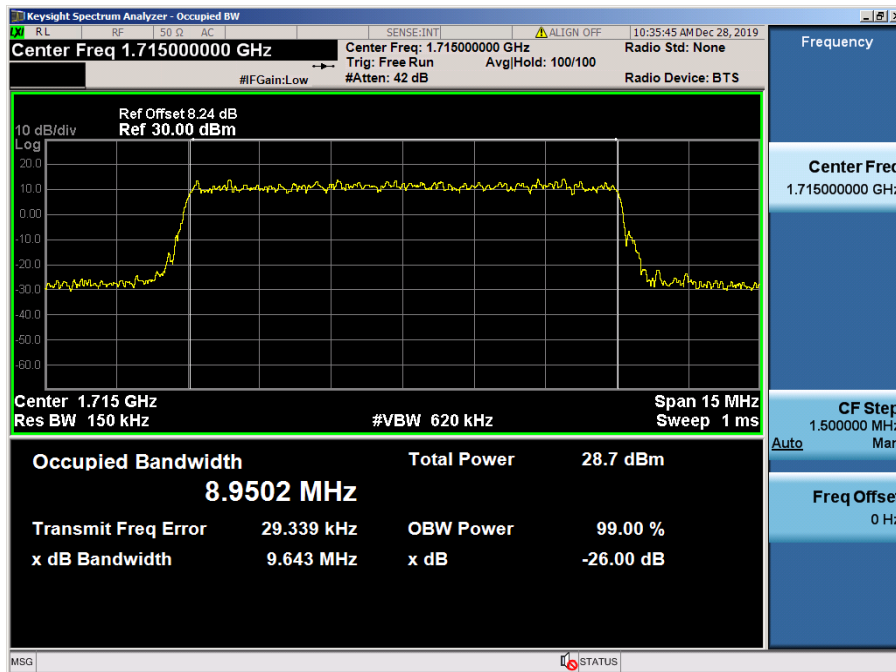

LTE Band 4 / 10 MHz / 16QAM - RB Size 50



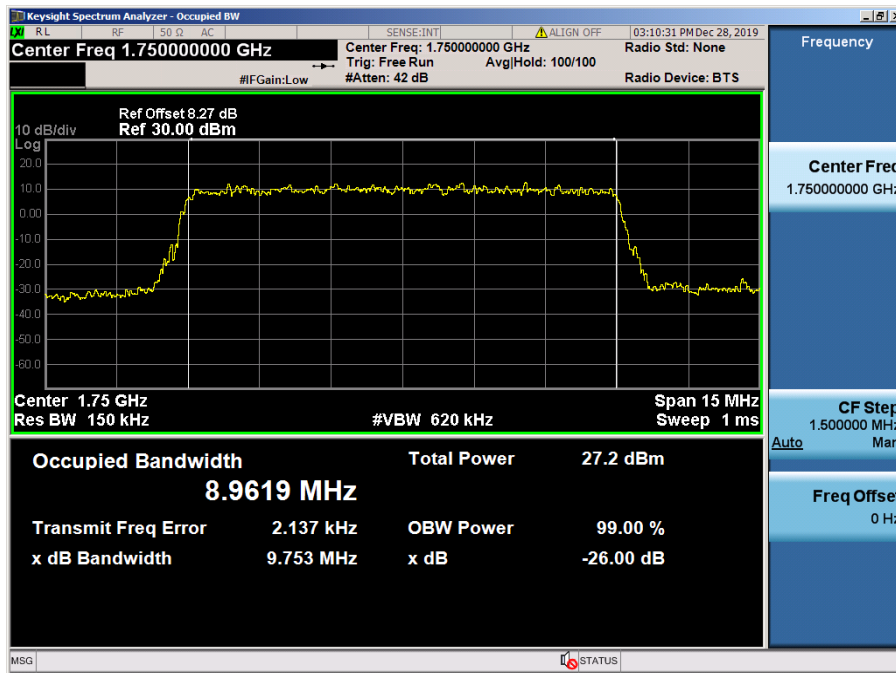

LTE Band 4 / 10 MHz / 64QAM - RB Size 50

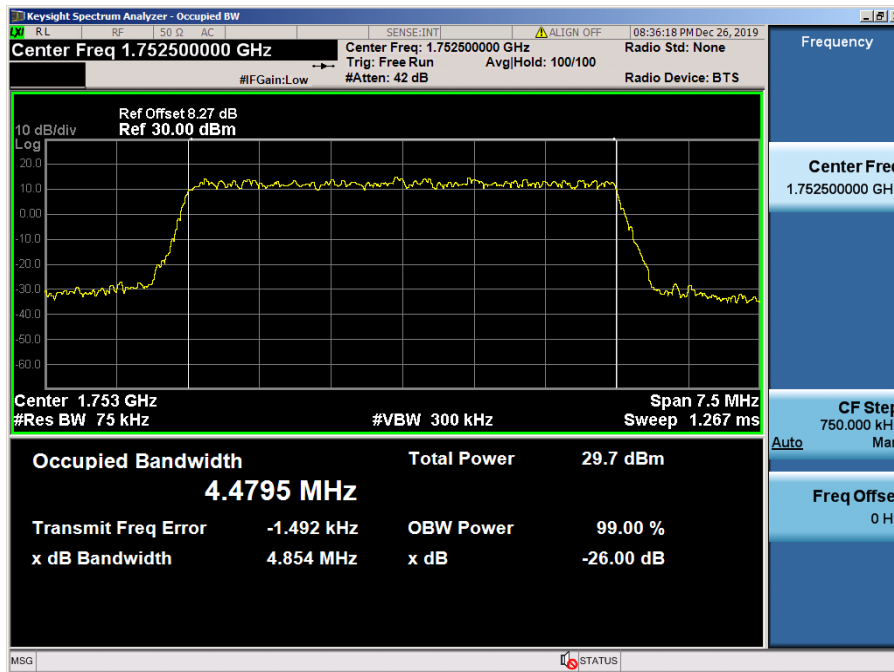

LTE Band 4 / 5 MHz / QPSK - RB Size 25

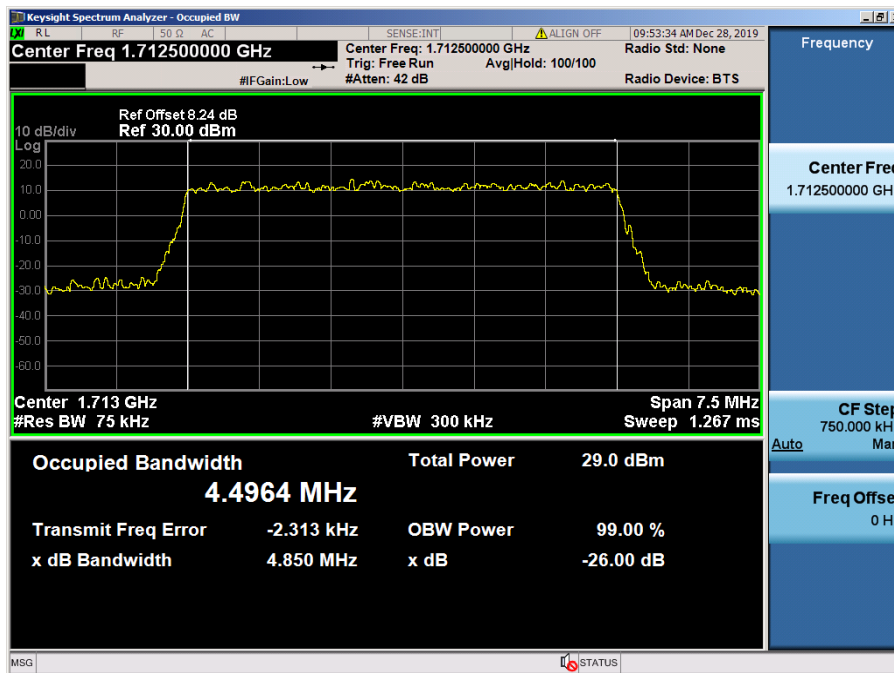

LTE Band 4 / 5 MHz / 16QAM - RB Size 25

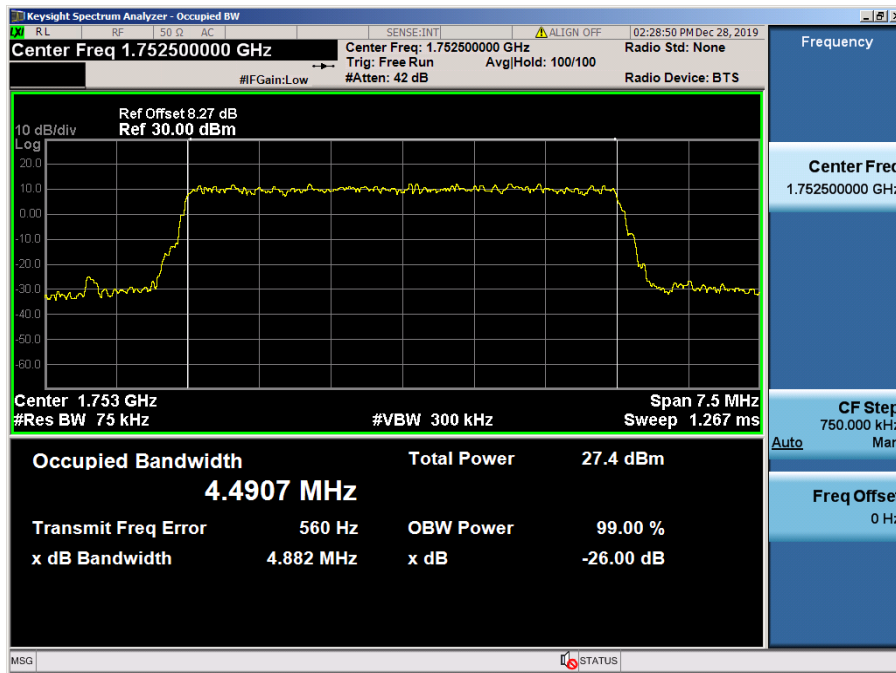

LTE Band 4 / 5 MHz / 64QAM - RB Size 25

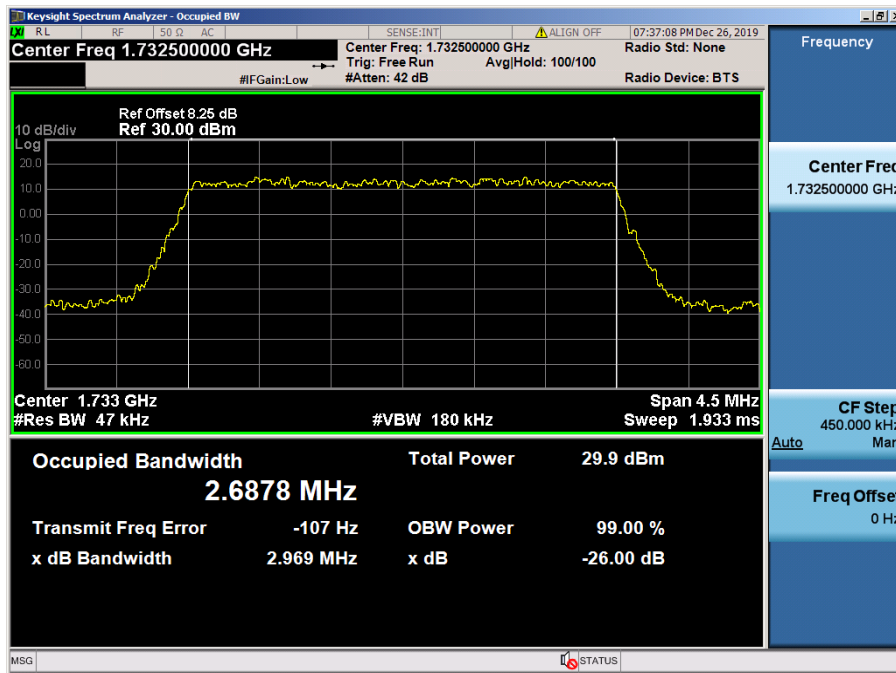

LTE Band 4 / 3 MHz / QPSK - RB Size 15

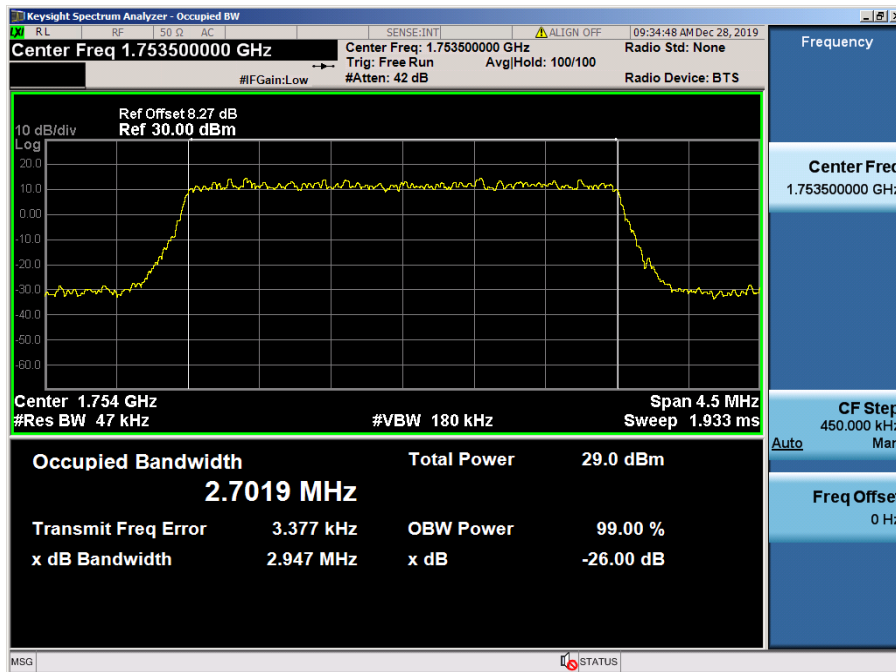

LTE Band 4 / 3 MHz / 16QAM - RB Size 15

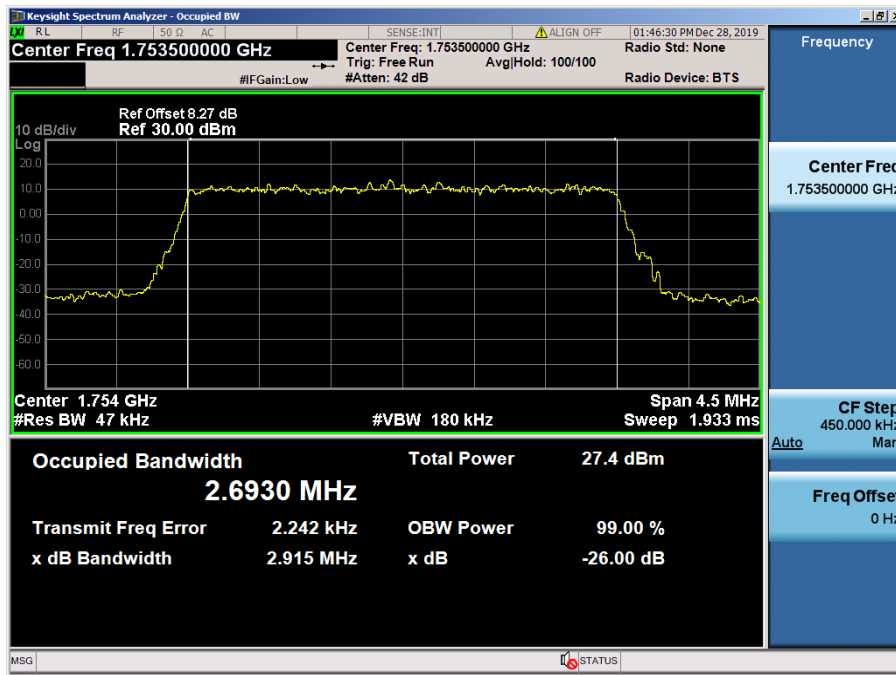

LTE Band 4 / 3 MHz / 64QAM - RB Size 15

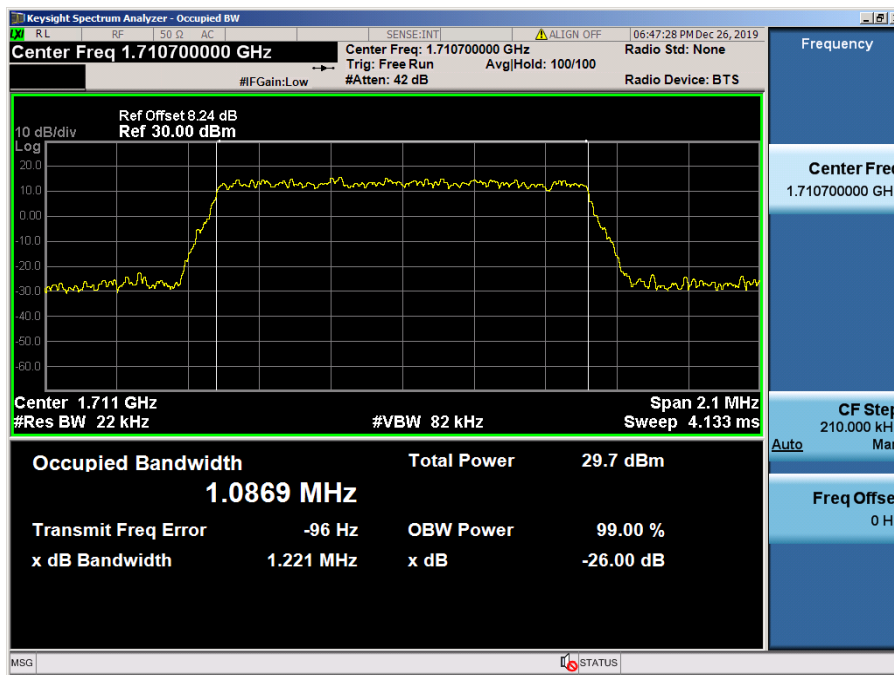

LTE Band 4 / 1.4 MHz / QPSK - RB Size 6

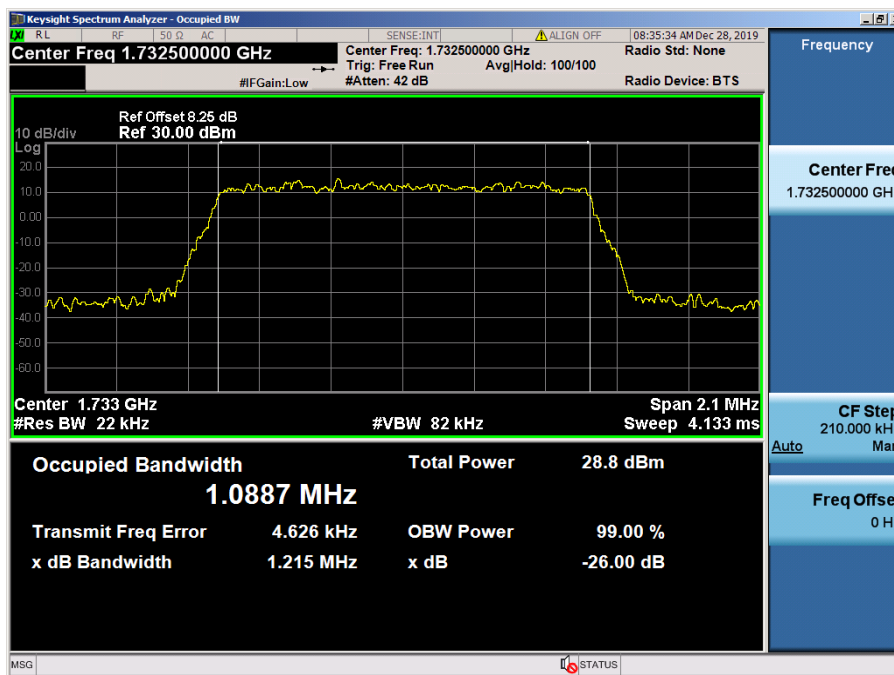

LTE Band 4 / 1.4 MHz / 16QAM - RB Size 6

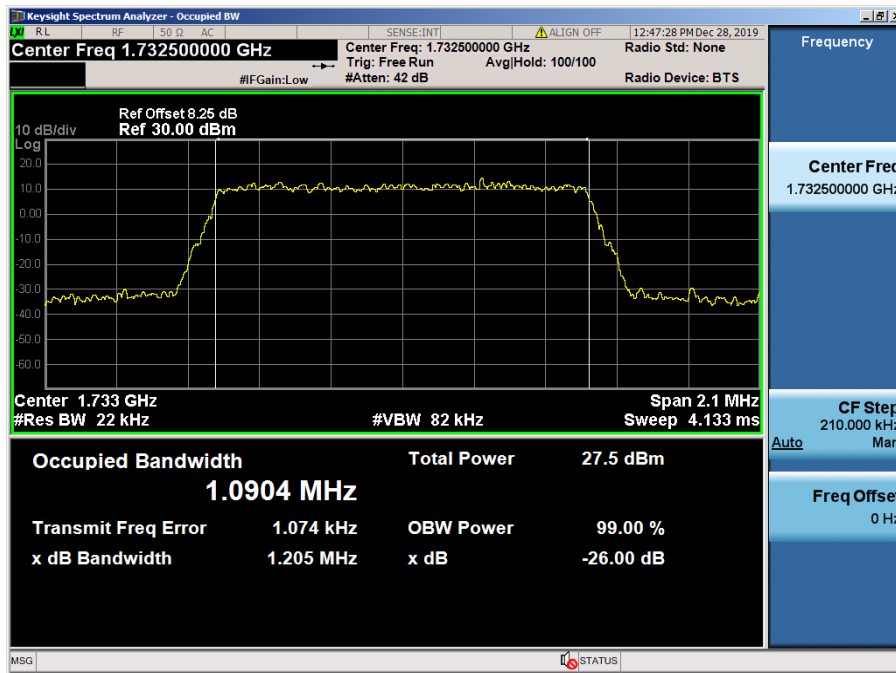

LTE Band 4 / 1.4 MHz / 64QAM - RB Size 6

8.1.5 LTE Band 2

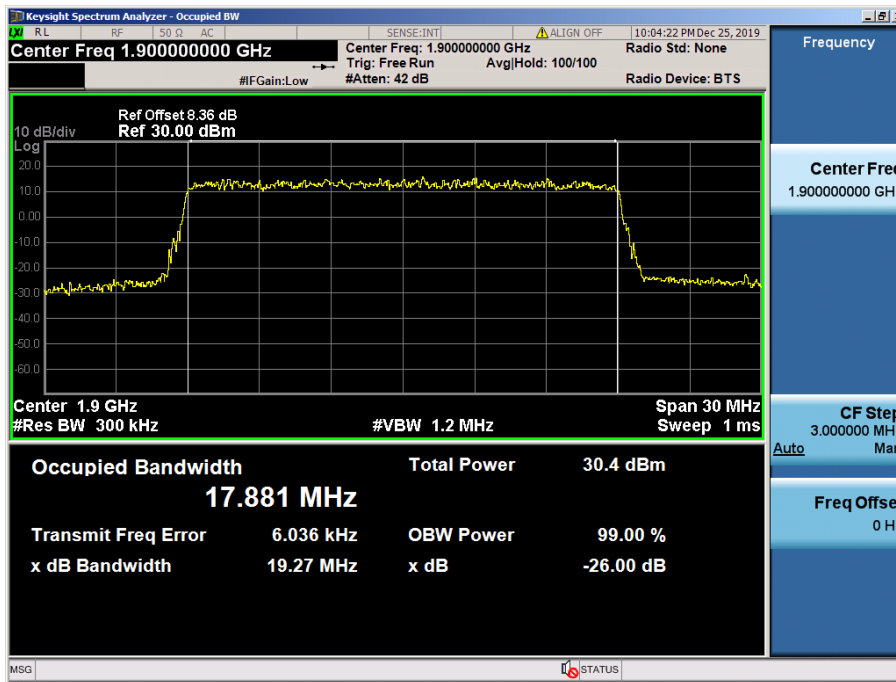

LTE Band 2 / 20 MHz / QPSK - RB Size 100

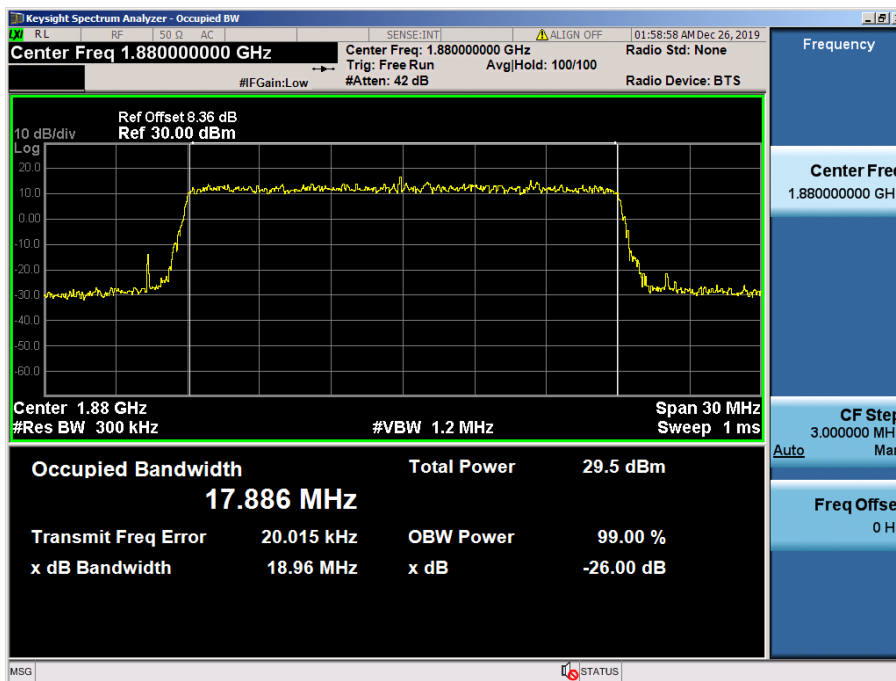

LTE Band 2 / 20 MHz / 16QAM - RB Size 100



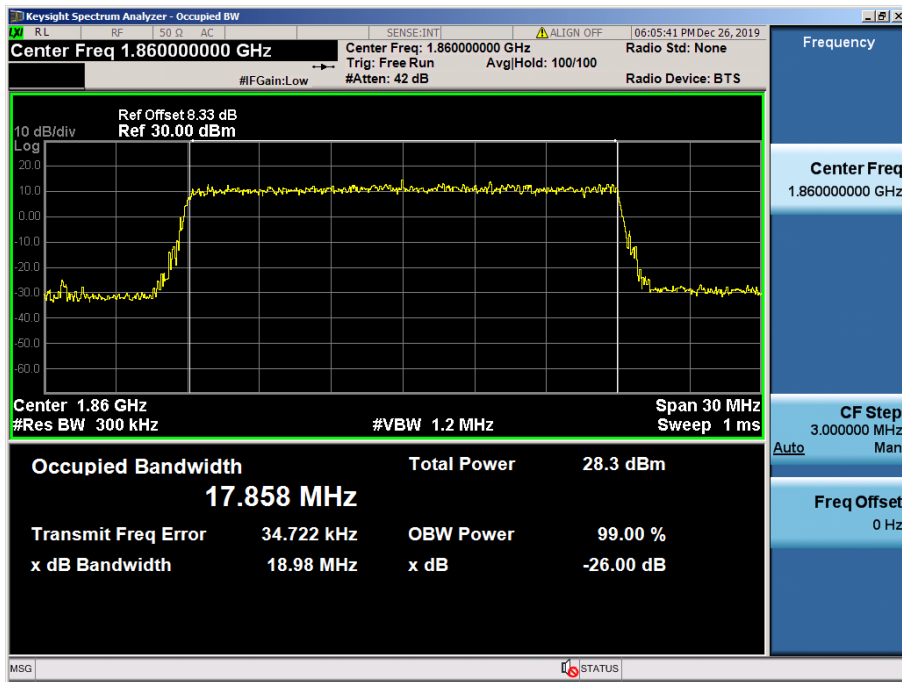

LTE Band 2 / 20 MHz / 64QAM - RB Size 100

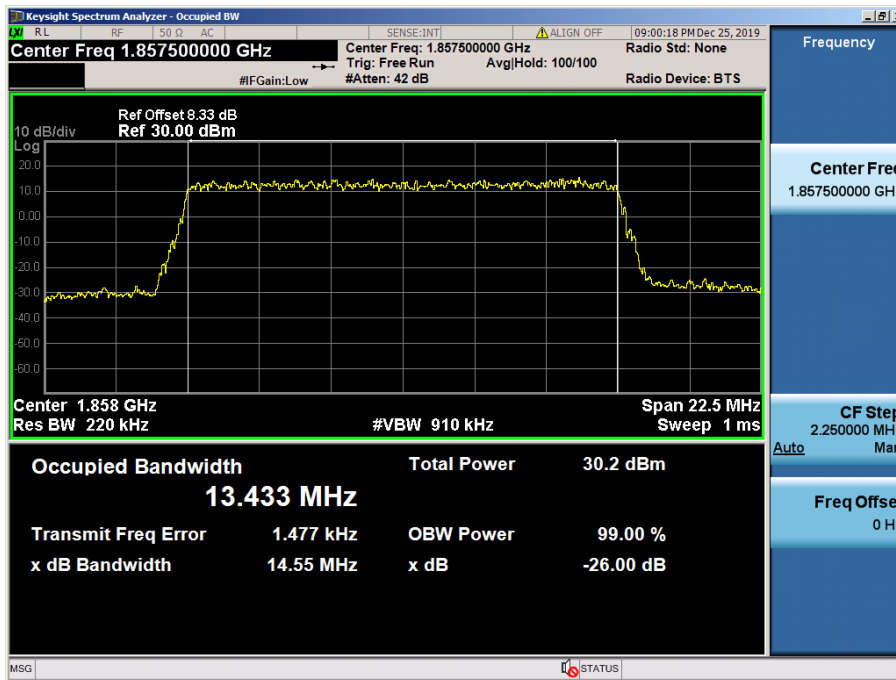

LTE Band 2 / 15 MHz / QPSK - RB Size 75

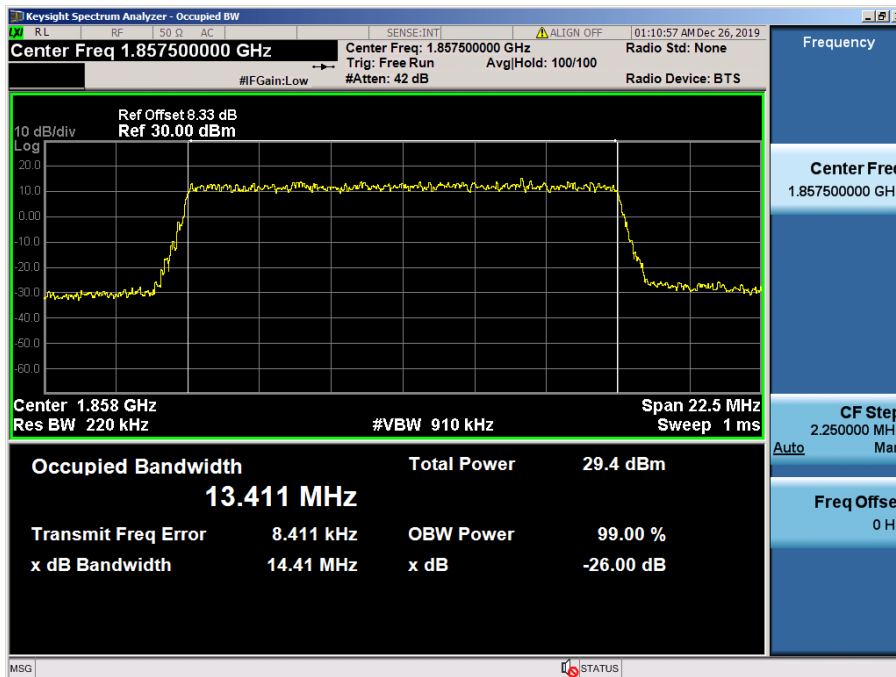

LTE Band 2 / 15 MHz / 16QAM - RB Size 75

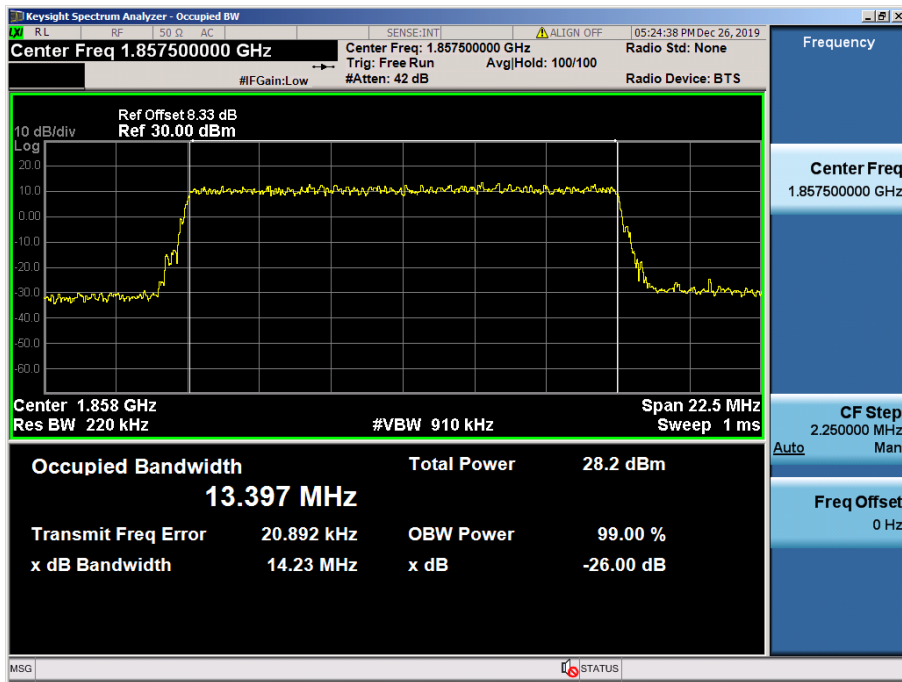

LTE Band 2 / 15 MHz / 64QAM - RB Size 75

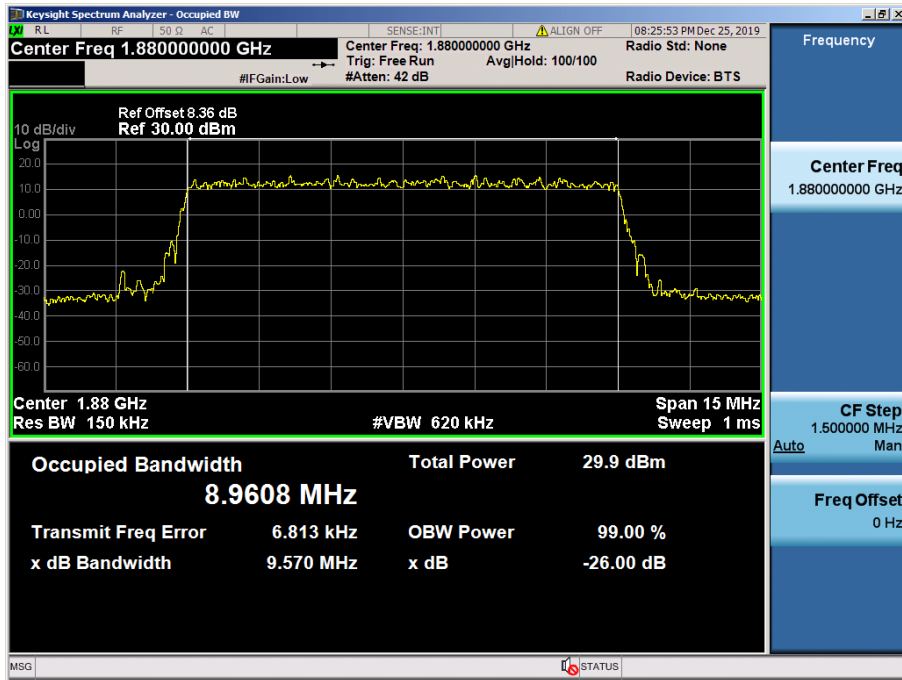

LTE Band 2 / 10 MHz / QPSK - RB Size 50

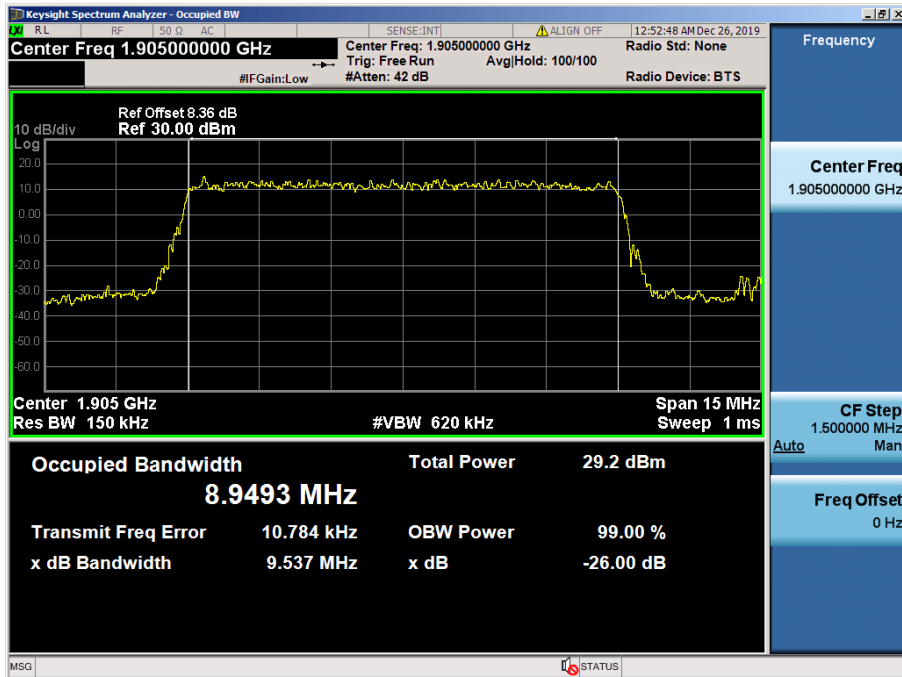

LTE Band 2 / 10 MHz / 16QAM - RB Size 50

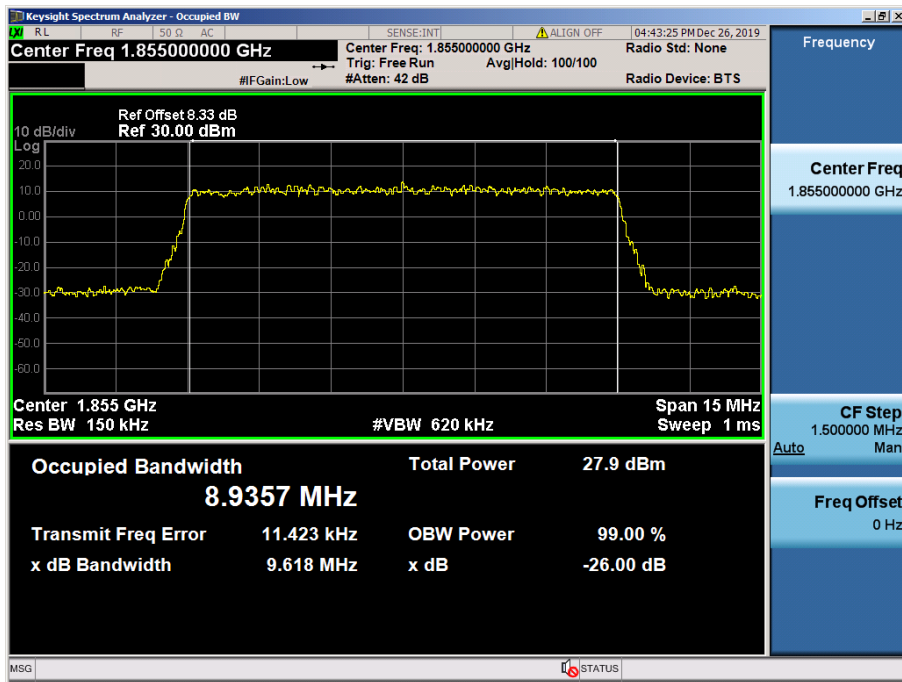

LTE Band 2 / 10 MHz / 64QAM - RB Size 50

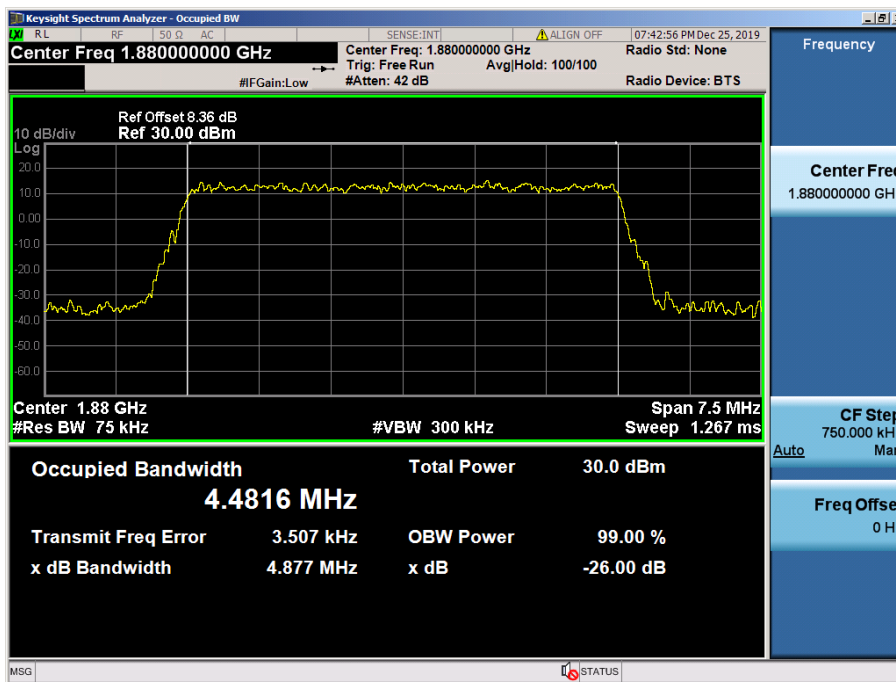

LTE Band 2 / 5 MHz / QPSK - RB Size 25

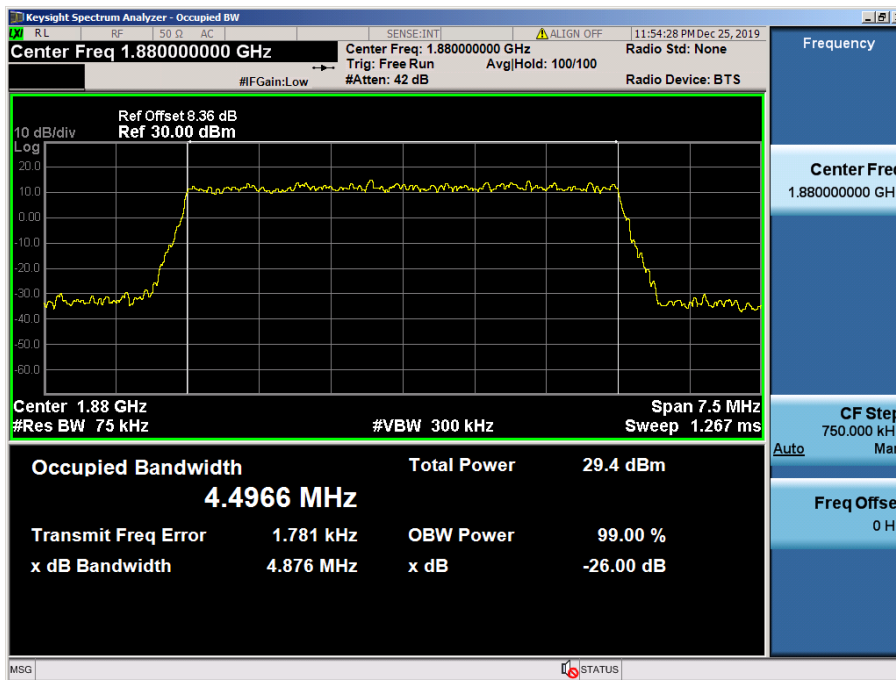

LTE Band 2 / 5 MHz / 16QAM - RB Size 25

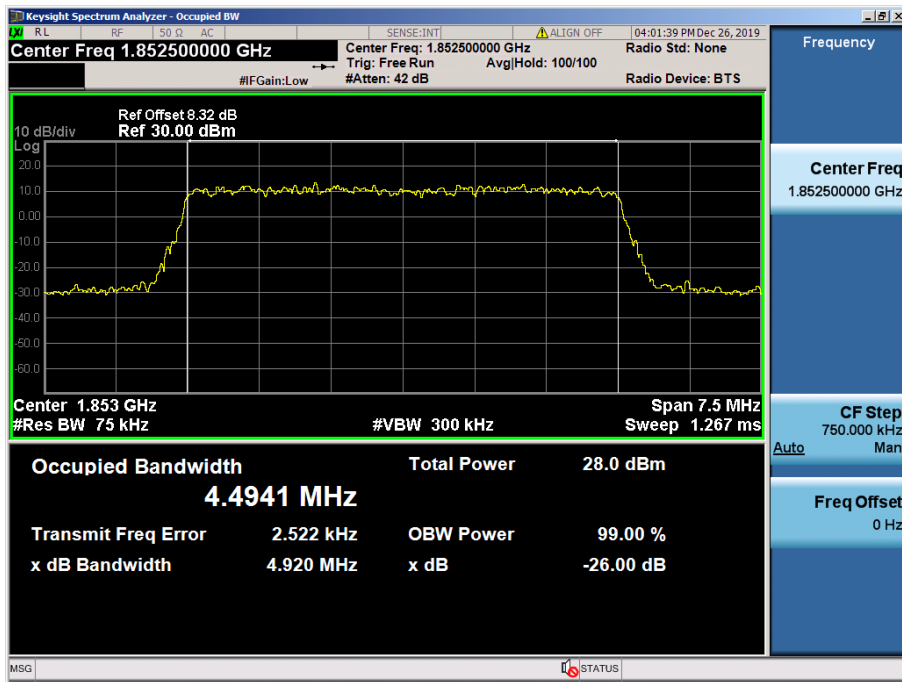

LTE Band 2 / 5 MHz / 64QAM - RB Size 25

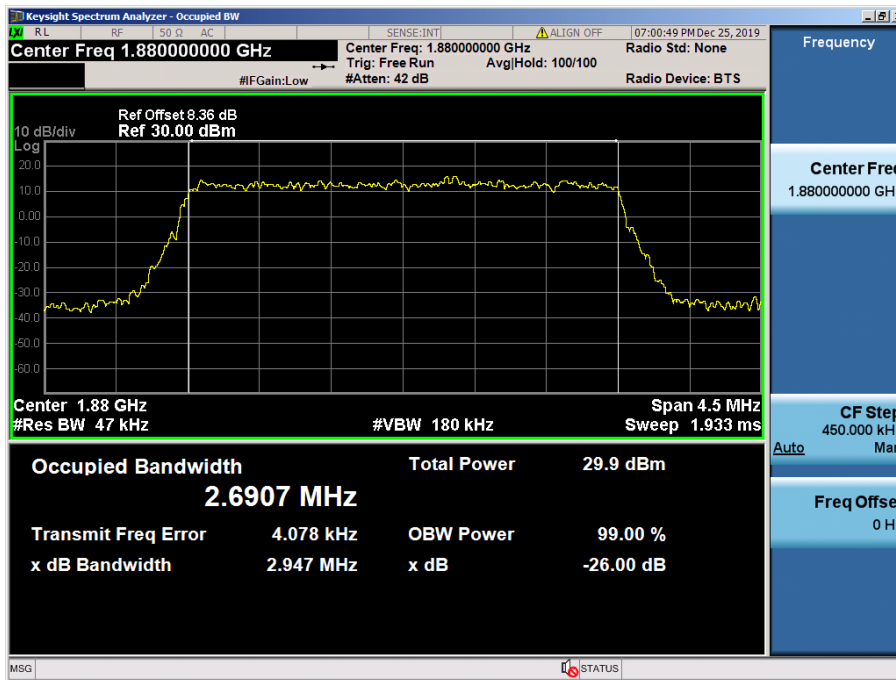

LTE Band 2 / 3 MHz / QPSK - RB Size 15

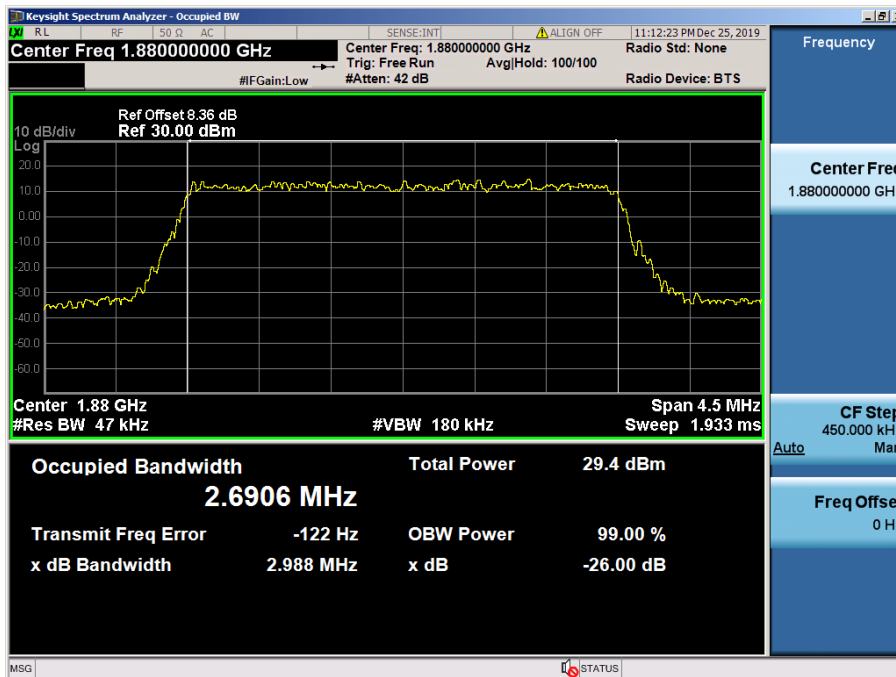

LTE Band 2 / 3 MHz / 16QAM - RB Size 15



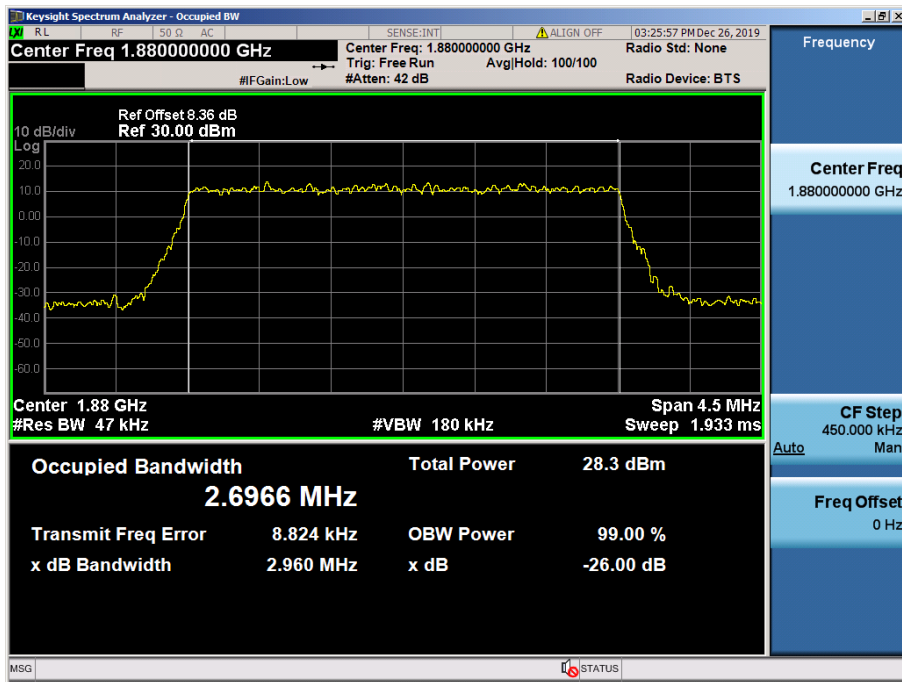

LTE Band 2 / 3 MHz / 64QAM - RB Size 15

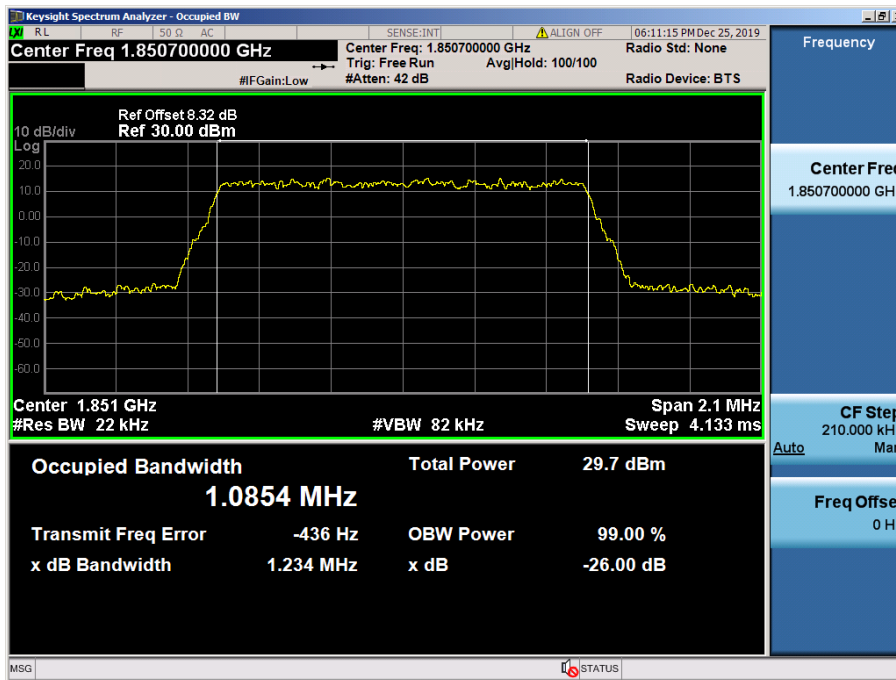

LTE Band 2 / 1.4 MHz / QPSK - RB Size 6

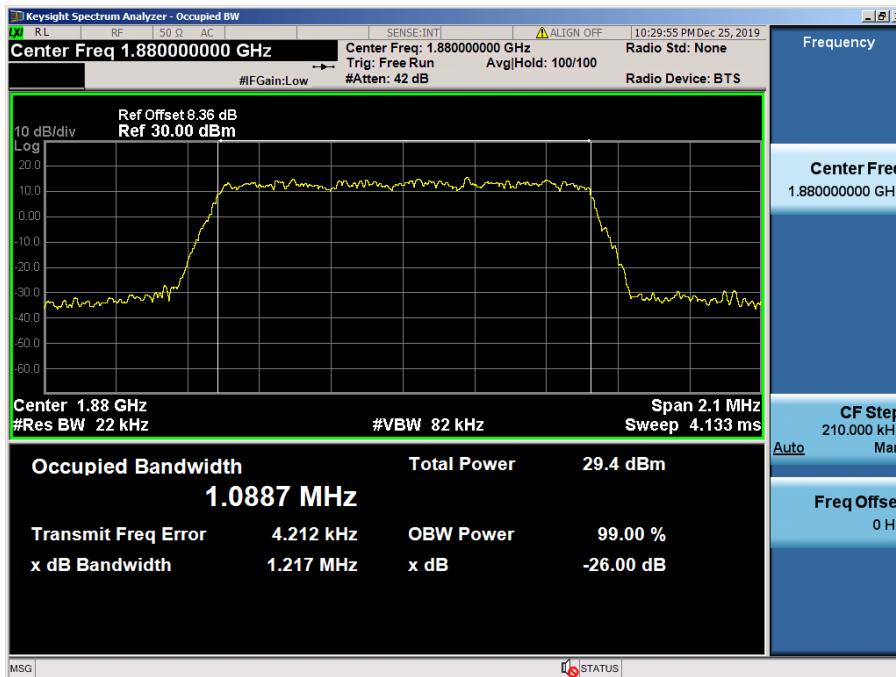

LTE Band 2 / 1.4 MHz / 16QAM - RB Size 6

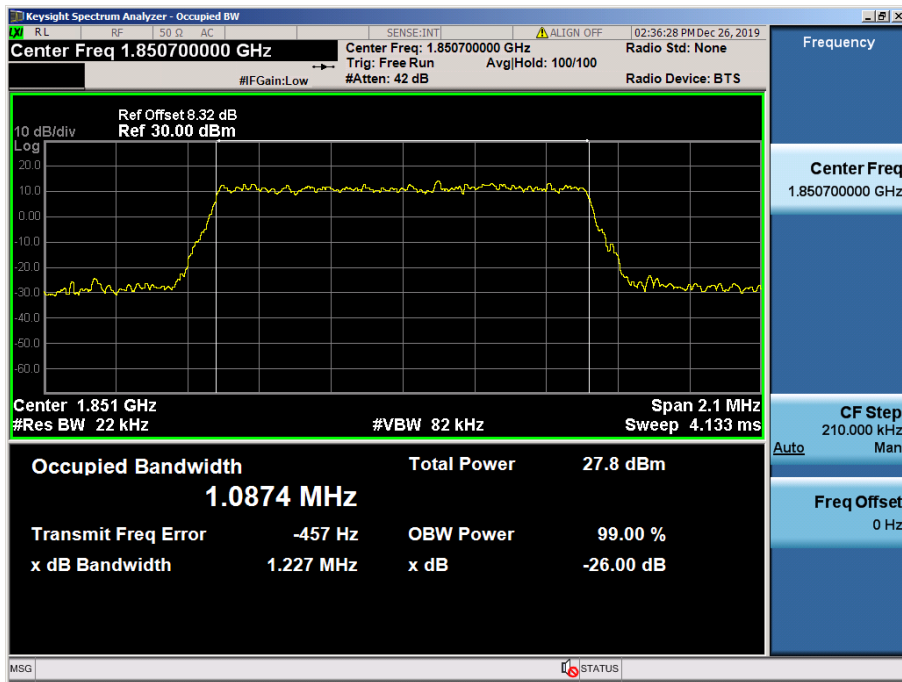

LTE Band 2 / 1.4 MHz / 64QAM - RB Size 6

## 8.2 PEAK TO AVERAGE RATIO

### 8.2.1 LTE Band 12, 17

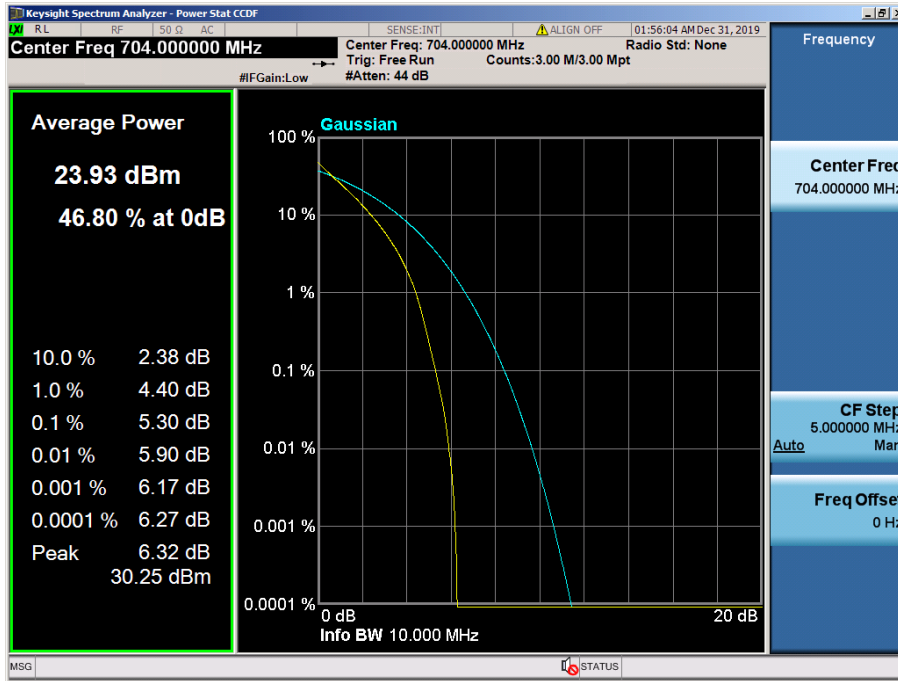

LTE Band 12, 17 / 10 MHz / QPSK - RB Size 50

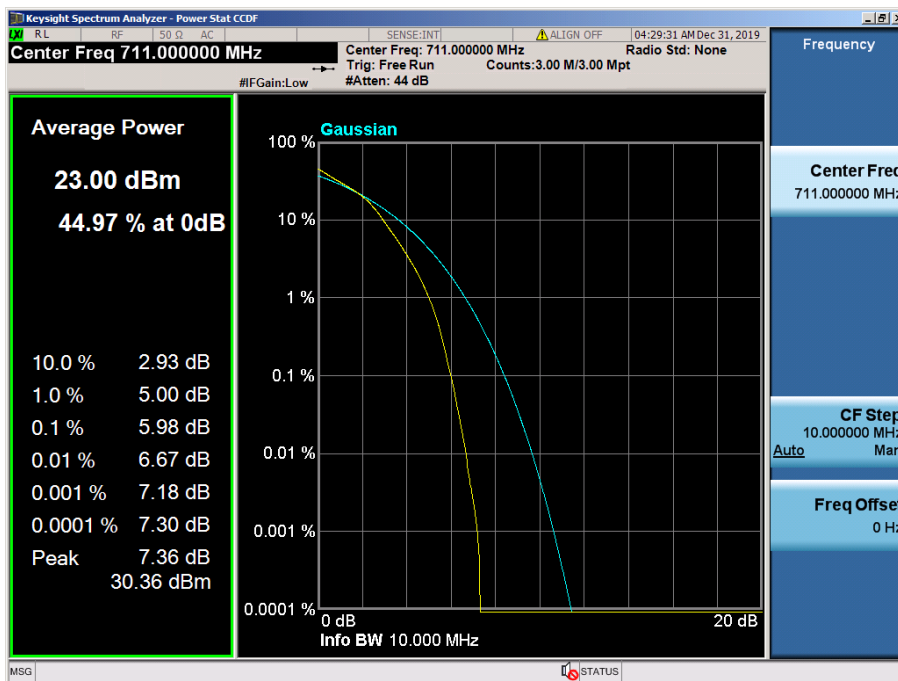

LTE Band 12, 17 / 10 MHz / 16QAM - RB Size 50