



SAR EVALUATION REPORT

Applicant Name:
 LG Electronics MobileComm U.S.A., Inc.
 1000 Sylvan Avenue
 Englewood Cliffs, NJ 07632
 United States

Date of Testing:
 03/16/15 - 03/25/15
Test Site/Location:
 PCTEST Lab, Columbia, MD, USA
Document Serial No.:
 0Y1503160550.ZNF

FCC ID: ZNFV495

APPLICANT: LG ELECTRONICS MOBILECOMM U.S.A., INC.

DUT Type: Portable Tablet
Application Type: Class II Permissive Change
FCC Rule Part(s): CFR §2.1093
Model(s): LG-V495, LGV495, V495, LG-V497, LGV497, V497
Permissive Change(s): See FCC change document
Date of Original Certification: 03/13/2015

Equipment Class	Band & Mode	Tx Frequency	SAR
			1 gm Body (W/kg)
PCB	UMTS 850	826.40 - 846.60 MHz	0.75
PCB	UMTS 1750	1712.4 - 1752.5 MHz	0.79
PCB	UMTS 1900	1852.4 - 1907.6 MHz	0.76
PCB	LTE Band 12	699.7 - 715.3 MHz	0.74
PCB	LTE Band 5 (Cell)	824.7 - 848.3 MHz	0.56
PCB	LTE Band 4 (AWS)	1710.7 - 1754.3 MHz	0.79
PCB	LTE Band 2 (PCS)	1850.7 - 1909.3 MHz	0.67
PCB	LTE Band 7	2502.5 - 2567.5 MHz	1.22
DTS	Bluetooth LE	2402 - 2480 MHz	N/A
DTS	2.4 GHz WLAN	2412 - 2462 MHz	0.47
NII	5.2 GHz WLAN	5180 - 5240 MHz	0.45
NII	5.3 GHz WLAN	5260 - 5320 MHz	0.52
NII	5.5 GHz WLAN	5500 - 5700 MHz	0.51
NII	5.8 GHz WLAN	5745 - 5825 MHz	0.32
DSS	Bluetooth	2402 - 2480 MHz	<0.1
Simultaneous SAR per KDB 690783 D01v01r03:			1.30

This wireless portable device has been shown to be capable of compliance for localized specific absorption rate (SAR) for uncontrolled environment/general population exposure limits specified in ANSI/IEEE C95.1-1992 and has been tested in accordance with the measurement procedures specified in Section 1.7 of this report; for North American frequency bands only.

I attest to the accuracy of data. All measurements reported herein were performed by me or were made under my supervision and are correct to the best of my knowledge and belief. I assume full responsibility for the completeness of these measurements and vouch for the qualifications of all persons taking them. Test results reported herein relate only to the item(s) tested.

 Randy Ortanez
 President



The SAR Tick is an initiative of the Mobile Manufacturers Forum (MMF). While a product may be considered eligible, use of the SAR Tick logo requires an agreement with the MMF. Further details can be obtained by emailing: sartick@mmfai.info.





FCC ID: ZNFV495	 PCTEST ENGINEERING LABORATORY, INC.	SAR EVALUATION REPORT	 LG	Reviewed by: Quality Manager
Document S/N: 0Y1503160550.ZNF	Test Dates: 03/16/15 - 03/25/15	DUT Type: Portable Tablet	Page 1 of 70	

TABLE OF CONTENTS

1	DEVICE UNDER TEST	3
2	LTE INFORMATION	8
3	INTRODUCTION	9
4	DOSIMETRIC ASSESSMENT	10
5	SAR TESTING PROCEDURES	11
6	RF EXPOSURE LIMITS	12
7	FCC MEASUREMENT PROCEDURES.....	13
8	RF CONDUCTED POWERS.....	17
9	SYSTEM VERIFICATION.....	48
10	SAR DATA SUMMARY	50
11	FCC MULTI-TX AND ANTENNA SAR CONSIDERATIONS.....	57
12	SAR MEASUREMENT VARIABILITY	64
13	EQUIPMENT LIST.....	65
14	MEASUREMENT UNCERTAINTIES	66
15	CONCLUSION.....	68
16	REFERENCES	69
APPENDIX A: SAR TEST PLOTS		
APPENDIX B: SAR DIPOLE VERIFICATION PLOTS		
APPENDIX C: PROBE AND DIPOLE CALIBRATION CERTIFICATES		
APPENDIX D: SAR TISSUE SPECIFICATIONS		
APPENDIX E: SAR SYSTEM VALIDATION		
APPENDIX F: SAR TEST SETUP PHOTOGRAPHS AND ANTENNA DIAGRAM		
APPENDIX G: SENSOR TRIGGERING DATA SUMMARY		

FCC ID: ZNFV495		SAR EVALUATION REPORT		Reviewed by: Quality Manager
Document S/N: 0Y1503160550.ZNF	Test Dates: 03/16/15 - 03/25/15	DUT Type: Portable Tablet	Page 2 of 70	

1 DEVICE UNDER TEST



1.1 Device Overview

Band & Mode	Operating Modes	Tx Frequency
UMTS 850	Data	826.40 - 846.60 MHz
UMTS 1750	Data	1712.4 - 1752.5 MHz
UMTS 1900	Data	1852.4 - 1907.6 MHz
LTE Band 12	Data	699.7 - 715.3 MHz
LTE Band 17	Data	706.5 - 713.5 MHz
LTE Band 5 (Cell)	Data	824.7 - 848.3 MHz
LTE Band 4 (AWS)	Data	1710.7 - 1754.3 MHz
LTE Band 2 (PCS)	Data	1850.7 - 1909.3 MHz
LTE Band 7	Data	2502.5 - 2567.5 MHz
Bluetooth LE	Data	2402 - 2480 MHz
2.4 GHz WLAN	Data	2412 - 2462 MHz
5.2 GHz WLAN	Data	5180 - 5240 MHz
5.3 GHz WLAN	Data	5260 - 5320 MHz
5.5 GHz WLAN	Data	5500 - 5700 MHz
5.8 GHz WLAN	Data	5745 - 5825 MHz
Bluetooth	Data	2402 - 2480 MHz

1.2 Power Reduction for SAR

This device uses a sensor for SAR compliance. The sensor is activated when used in close proximity to the user's body. The sensor triggers power reduction for data modes and is only applicable for tablet operations.

Since the device is a full sized tablet, the Body SAR was evaluated per FCC KDB Publication 616217 D04 for full sized tablets.



FCC ID: ZNFV495	 PCTEST ENGINEERING LABORATORY, INC.	SAR EVALUATION REPORT		Reviewed by: Quality Manager
Document S/N: 0Y1503160550.ZNF	Test Dates: 03/16/15 - 03/25/15	DUT Type: Portable Tablet	Page 3 of 70	

1.3 Nominal and Maximum Output Power Specifications

This device operates using the following maximum and nominal output power specifications. SAR values were scaled to the maximum allowed power to determine compliance per KDB Publication 447498 D01v05.

Mode / Band		Proximity Sensor State	Modulated Average		
			3GPP WCDMA Rel 99	3GPP HSDPA Rel 5	3GPP HSUPA Rel 6
UMTS Band 5 (850 MHz)	Maximum	Inactive	24.7	24.7	24.7
	Nominal		24.2	24.2	24.2
UMTS Band 5 (850 MHz)	Maximum	Active	20.7	20.7	20.7
	Nominal		20.2	20.2	20.2
UMTS Band 4 (1750 MHz)	Maximum	Inactive	24.2	24.2	24.2
	Nominal		23.7	23.7	23.7
UMTS Band 4 (1750 MHz)	Maximum	Active	13.2	13.2	13.2
	Nominal		12.7	12.7	12.7
UMTS Band 2 (1900 MHz)	Maximum	Inactive	23.7	23.7	23.7
	Nominal		23.2	23.2	23.2
UMTS Band 2 (1900 MHz)	Maximum	Active	12.7	12.7	12.7
	Nominal		12.2	12.2	12.2

Mode / Band		Proximity Sensor State	Modulated Average (dBm)
LTE Band 12	Maximum	Inactive	24.7
	Nominal		24.2
LTE Band 12	Maximum	Active	20.7
	Nominal		20.2
LTE Band 17	Maximum	Inactive	24.7
	Nominal		24.2
LTE Band 17	Maximum	Active	20.7
	Nominal		20.2
LTE Band 5 (Cell)	Maximum	Inactive	24.2
	Nominal		23.7
LTE Band 5 (Cell)	Maximum	Active	20.2
	Nominal		19.7
LTE Band 4 (AWS)	Maximum	Inactive	24.2
	Nominal		23.7
LTE Band 4 (AWS)	Maximum	Active	13.2
	Nominal		12.7
LTE Band 2 (PCS)	Maximum	Inactive	23.7
	Nominal		23.2
LTE Band 2 (PCS)	Maximum	Active	12.7
	Nominal		12.2
LTE Band 7	Maximum	Inactive	24.2
	Nominal		23.7
LTE Band 7	Maximum	Active	9.2
	Nominal		8.7

FCC ID: ZNFV495	 PCTEST ENGINEERING LABORATORY, INC.	SAR EVALUATION REPORT		Reviewed by: Quality Manager
Document S/N: OY1503160550.ZNF	Test Dates: 03/16/15 - 03/25/15	DUT Type: Portable Tablet		Page 4 of 70

Mode / Band		Modulated Average (dBm)
IEEE 802.11b (2.4 GHz)	Maximum	13.0
	Nominal	12.0
IEEE 802.11g (2.4 GHz)	Maximum	11.0
	Nominal	10.0
IEEE 802.11n (2.4 GHz)	Maximum	10.0
	Nominal	9.0
IEEE 802.11a (5 GHz) 20 MHz BW	Maximum	10.0
	Nominal	9.0
IEEE 802.11n (5 GHz) 20 MHz BW	Maximum	9.0
	Nominal	8.0
IEEE 802.11n (5 GHz) 40 MHz BW	Maximum	8.0
	Nominal	7.0
Bluetooth	Maximum	9.5
	Nominal	8.5
Bluetooth LE	Maximum	0.5
	Nominal	-0.5



1.4 Sides for SAR Testing

The overall diagonal dimension of the device is > 200 mm. A diagram showing the locations of the device antennas can be found in Appendix F: Exact antenna dimensions and separation distances are shown in the Technical Descriptions in the FCC filing.

**Table 1-1
Sides for SAR Testing**

Mode	Back	Front	Top	Bottom	Right	Left
UMTS 850	Yes	No	Yes	No	Yes	Yes
UMTS 1750	Yes	No	Yes	No	Yes	Yes
UMTS 1900	Yes	No	Yes	No	Yes	Yes
LTE Band 12	Yes	No	Yes	No	Yes	Yes
LTE Band 5 (Cell)	Yes	No	Yes	No	Yes	Yes
LTE Band 4 (AWS)	Yes	No	Yes	No	Yes	Yes
LTE Band 2 (PCS)	Yes	No	Yes	No	Yes	Yes
LTE Band 7	Yes	No	Yes	No	Yes	Yes
2.4 GHz WLAN	Yes	No	Yes	No	Yes	Yes
2.4 GHz Bluetooth	Yes	No	Yes	No	Yes	Yes
5 GHz WLAN	Yes	No	Yes	No	Yes	Yes

Note: Per FCC KDB 616217 D04v01r01, particular DUT edges were not required to be evaluated for SAR based on the SAR exclusion threshold in KDB 447498 D01v05r01.

FCC ID: ZNFV495	 PCTEST ENGINEERING LABORATORY, INC.	SAR EVALUATION REPORT	 LG	Reviewed by: Quality Manager
Document S/N: OY1503160550.ZNF	Test Dates: 03/16/15 - 03/25/15	DUT Type: Portable Tablet	Page 5 of 70	

1.5 Simultaneous Transmission Capabilities

According to FCC KDB Publication 447498 D05v01, transmitters are considered to be transmitting simultaneously when there is overlapping transmission, with the exception of transmissions during network hand-offs with maximum hand-off duration less than 30 seconds. Possible transmission paths for the DUT are shown in Figure 1-1 and are color-coded to indicate communication modes which share the same path. Modes which share the same transmission path cannot transmit simultaneously with one another.



Figure 1-1
Simultaneous Transmission Paths

This device contains multiple transmitters that may operate simultaneously, and therefore requires a simultaneous transmission analysis according to FCC KDB Publication 447498 D01v05 3) procedures.

Table 1-2
Simultaneous Transmission Scenarios

No.	Capable Transmit Configuration	Body
1	UMTS + 2.4 GHz WI-FI	Yes
2	UMTS + 5 GHz WI-FI	Yes
3	UMTS + 2.4 GHz Bluetooth	Yes
4	LTE + 2.4 GHz WI-FI	Yes
5	LTE + 2.4 GHz Bluetooth	Yes
6	LTE + 5 GHz WI-FI	Yes

- 2.4 GHz WLAN, 5 GHz WLAN, and 2.4 GHz Bluetooth share the same antenna path and cannot transmit simultaneously.
- All licensed modes share the same antenna path and cannot transmit simultaneously.

1.6 SAR Test Exclusions Applied



(A) WIFI/BT

Per FCC KDB 447498 D01v05, the 1g SAR exclusion threshold for distances <50mm is defined by the following equation:

$$\frac{\text{Max Power of Channel (mW)}}{\text{Test Separation Dist (mm)}} * \sqrt{\text{Frequency(GHz)}} \leq 3.0$$

Based on the maximum conducted power of Bluetooth LE (rounded to the nearest mW) and the antenna to user separation distance, body Bluetooth LE SAR was not required; $[(1/5) * \sqrt{2.480}] = 0.3 < 3.0$. Per KDB Publication 447498 D01v05, the maximum power of the channel was rounded to the nearest mW before calculation.

This device supports 20 MHz and 40 MHz Bandwidths for IEEE 802.11n for 5 GHz WIFI only.

FCC ID: ZNFV495	 PCTEST ENGINEERING LABORATORY, INC.	SAR EVALUATION REPORT		Reviewed by: Quality Manager
Document S/N: OY1503160550.ZNF	Test Dates: 03/16/15 - 03/25/15	DUT Type: Portable Tablet		Page 6 of 70

(B) Licensed Transmitter(s)

This device is only capable of QPSK HSUPA in the uplink. Therefore, no additional SAR tests are required beyond that described for devices with HSUPA in KDB 941225 D01v03.

This device additionally supports LTE Band 17. LTE Band 12 and LTE Band 17 share the same transmission path. LTE Band 17 was not evaluated for SAR since the supported frequency range falls within the LTE Band 12 supported frequency range and the Band 17 target power was equal to the Band 12 target power.

LTE SAR for the higher modulations and lower bandwidths were not tested since the maximum average output power of all required channels and configurations was not more than 0.5 dB higher than the highest bandwidth; and the reported LTE SAR for the highest bandwidth was less than 1.45 W/kg for all configurations according to FCC KDB 941225 D05v02r03.

This device supports inter-band LTE Carrier Aggregation (CA) in the downlink only. All uplink communications are identical to Release 8 specifications. Per FCC Guidance, LTE CA SAR was not required for testing since the data sent by uplink on uplink physical channels does not change between Rel 8 and Rel 10.



1.7 Guidance Applied

- FCC KDB Publication 941225 D01v03, D05v02r03, D05Av01r01 (3G/4G)
- FCC KDB Publication 248227 D01v01r02 (SAR Considerations for 802.11 Devices)
- FCC KDB Publication 447498 D01v05r02 (General SAR Guidance)
- FCC KDB Publication 865664 D01v01r03, D02v01r01 (SAR Measurements up to 6 GHz)
- FCC KDB Publication 616217 D04v01r01 (Tablet SAR Considerations)

1.8 Device Serial Numbers

Several samples with identical hardware were used to support SAR testing. The manufacturer has confirmed that the device(s) tested have the same physical, mechanical and thermal characteristics and are within operational tolerances expected for production units.



	Maximum Power Serial Number	Reduced Power Serial Number
UMTS 850	1TRPA	1TRPJ
UMTS 1750	1TRPA	1TRPJ
UMTS 1900	1TRPA	1TRPJ
LTE Band 12	1TRP7	1TRP8
LTE Band 5 (Cell)	1TRP7	1TRP8
LTE Band 4 (AWS)	1TRP7	1TRP8
LTE Band 2 (PCS)	1TRP7	1TRP8
LTE Band 7	1TRP7	1TRP8
2.4 GHz WLAN	1TRNY	N/A
5 GHz WLAN	1TRNW	N/A
Bluetooth	1TRNY	N/A

FCC ID: ZNFV495	 PCTEST ENGINEERING LABORATORY, INC.	SAR EVALUATION REPORT		Reviewed by: Quality Manager
Document S/N: OY1503160550.ZNF	Test Dates: 03/16/15 - 03/25/15	DUT Type: Portable Tablet	Page 7 of 70	

2

LTE INFORMATION

LTE Information					
FCC ID	ZNFV495				
Form Factor	Portable Tablet				
Frequency Range of each LTE transmission band	LTE Band 12 (699.7 - 715.3 MHz)				
	LTE Band 17 (706.5 - 713.5 MHz)				
	LTE Band 5 (Cell) (824.7 - 848.3 MHz)				
	LTE Band 4 (AWS) (1710.7 - 1754.3 MHz)				
	LTE Band 2 (PCS) (1850.7 - 1909.3 MHz)				
	LTE Band 7 (2502.5 - 2567.5 MHz)				
Channel Bandwidths	LTE Band 12: 1.4 MHz, 3 MHz, 5 MHz, 10 MHz				
	LTE Band 17: 5 MHz, 10 MHz				
	LTE Band 5 (Cell): 1.4 MHz, 3 MHz, 5 MHz, 10 MHz				
	LTE Band 4 (AWS): 1.4 MHz, 3 MHz, 5 MHz, 10 MHz, 15 MHz, 20 MHz				
	LTE Band 2 (PCS): 1.4 MHz, 3 MHz, 5 MHz, 10 MHz, 15 MHz, 20 MHz				
Channel Numbers and Frequencies (MHz)	Low	Mid	High		
	LTE Band 12: 1.4 MHz	699.7 (23017)	707.5 (23095)	715.3 (23173)	
LTE Band 12: 3 MHz	700.5 (23025)	707.5 (23095)	714.5 (23165)		
LTE Band 12: 5 MHz	701.5 (23035)	707.5 (23095)	713.5 (23155)		
LTE Band 12: 10 MHz	704 (23060)	707.5 (23095)	711 (23130)		
LTE Band 17: 5 MHz	706.5 (23085)	710 (23790)	713.5 (23825)		
LTE Band 17: 10 MHz	709 (23780)	710 (23790)	711 (23800)		
LTE Band 5 (Cell): 1.4 MHz	824.7 (20407)	836.5 (20525)	848.3 (20643)		
LTE Band 5 (Cell): 3 MHz	825.5 (20415)	836.5 (20525)	847.5 (20635)		
LTE Band 5 (Cell): 5 MHz	826.5 (20425)	836.5 (20525)	846.5 (20625)		
LTE Band 5 (Cell): 10 MHz	829 (20450)	836.5 (20525)	844 (20600)		
LTE Band 4 (AWS): 1.4 MHz	1710.7 (19957)	1732.5 (20175)	1754.3 (20393)		
LTE Band 4 (AWS): 3 MHz	1711.5 (19965)	1732.5 (20175)	1753.5 (20385)		
LTE Band 4 (AWS): 5 MHz	1712.5 (19975)	1732.5 (20175)	1752.5 (20375)		
LTE Band 4 (AWS): 10 MHz	1715 (20000)	1732.5 (20175)	1750 (20350)		
LTE Band 4 (AWS): 15 MHz	1717.5 (20025)	1732.5 (20175)	1747.5 (20325)		
LTE Band 4 (AWS): 20 MHz	1720 (20050)	1732.5 (20175)	1745 (20300)		
LTE Band 2 (PCS): 1.4 MHz	1850.7 (18607)	1880 (18900)	1909.3 (19193)		
LTE Band 2 (PCS): 3 MHz	1851.5 (18615)	1880 (18900)	1908.5 (19185)		
LTE Band 2 (PCS): 5 MHz	1852.5 (18625)	1880 (18900)	1907.5 (19175)		
LTE Band 2 (PCS): 10 MHz	1855 (18650)	1880 (18900)	1905 (19150)		
LTE Band 2 (PCS): 15 MHz	1857.5 (18675)	1880 (18900)	1902.5 (19125)		
LTE Band 2 (PCS): 20 MHz	1860 (18700)	1880 (18900)	1900 (19100)		
LTE Band 7: 5 MHz	2502.5 (20775)	2535 (21100)	2567.5 (21425)		
LTE Band 7: 10 MHz	2505 (20800)	2535 (21100)	2565 (21400)		
LTE Band 7: 15 MHz	2507.5 (20825)	2535 (21100)	2562.5 (21375)		
LTE Band 7: 20 MHz	2510 (20850)	2535 (21100)	2560 (21350)		
UE Category	4				
Modulations Supported in UL	QPSK, 16QAM				
LTE MPR Permanently implemented per 3GPP TS 36.101 section 6.2.3~6.2.5? (manufacturer attestation to be provided)	YES				
A-MPR (Additional MPR) disabled for SAR Testing?	YES				
LTE Carrier Aggregation Possible Combinations	LTE B4 (PCC) + LTE B12 (SCC)	LTE B4 (PCC) + LTE B17 (SCC)	LTE B4 (PCC) + LTE B29 (SCC)	LTE B2 (PCC) + LTE B17 (SCC)	LTE B2 (PCC) + LTE B29 (SCC)
	5MHz (B4) + 5MHz (B12)	5MHz (B4) + 5MHz (B17)	5MHz (B4) + 5MHz (B29)	5MHz (B2) + 5MHz (B17)	5MHz (B2) + 5MHz (B29)
	5MHz (B4) + 10MHz (B12)	5MHz (B4) + 10MHz (B17)	5MHz (B4) + 10MHz (B29)	5MHz (B2) + 10MHz (B17)	5MHz (B2) + 10MHz (B29)
	10MHz (B4) + 5MHz (B12)	10MHz (B4) + 5MHz (B17)	10MHz (B4) + 5MHz (B29)	10MHz (B2) + 5MHz (B17)	10MHz (B2) + 5MHz (B29)
	10MHz (B4) + 10MHz (B12)	10MHz (B4) + 10MHz (B17)	10MHz (B4) + 10MHz (B29)	10MHz (B2) + 10MHz (B17)	10MHz (B2) + 10MHz (B29)
LTE Carrier Aggregation Additional Information	This device does not support full CA features on 3GPP Release 10. It supports a maximum of 2 carriers in the downlink only. All uplink communications are identical to the Release 8 Specifications. Uplink communications are done on the PCC. Due to carrier capability, only the combinations listed above are supported. The following LTE Release 10 Features are not supported: Relay, HetNet, Enhanced MIMO, eICl, WiFi Offloading, MCH, eMBMA, Cross-Carrier Scheduling, Enhanced SC-FDMA.				

FCC ID: ZNFV495	 PCTEST ENGINEERING LABORATORY, INC.	SAR EVALUATION REPORT		Reviewed by: Quality Manager
Document S/N: OY1503160550.ZNF	Test Dates: 03/16/15 - 03/25/15	DUT Type: Portable Tablet	Page 8 of 70	

3 INTRODUCTION

The FCC and Industry Canada have adopted the guidelines for evaluating the environmental effects of radio frequency (RF) radiation in ET Docket 93-62 on Aug. 6, 1996 and Health Canada Safety Code 6 to protect the public and workers from the potential hazards of RF emissions due to FCC-regulated portable devices. [1]

The safety limits used for the environmental evaluation measurements are based on the criteria published by the American National Standards Institute (ANSI) for localized specific absorption rate (SAR) in IEEE/ANSI C95.1-1992 Standard for Safety Levels with Respect to Human Exposure to Radio Frequency Electromagnetic Fields, 3 kHz to 300 GHz [3] and Health Canada RF Exposure Guidelines Safety Code 6 [22]. The measurement procedure described in IEEE/ANSI C95.3-2002 Recommended Practice for the Measurement of Potentially Hazardous Electromagnetic Fields - RF and Microwave [4] is used for guidance in measuring the Specific Absorption Rate (SAR) due to the RF radiation exposure from the Equipment Under Test (EUT). These criteria for SAR evaluation are similar to those recommended by the International Committee for Non-Ionizing Radiation Protection (ICNIRP) in Biological Effects and Exposure Criteria for Radiofrequency Electromagnetic Fields,” Report No. Vol 74. SAR is a measure of the rate of energy absorption due to exposure to an RF transmitting source. SAR values have been related to threshold levels for potential biological hazards.

3.1 SAR Definition

Specific Absorption Rate is defined as the time derivative (rate) of the incremental energy (dU) absorbed by (dissipated in) an incremental mass (dm) contained in a volume element (dV) of a given density (ρ). It is also defined as the rate of RF energy absorption per unit mass at a point in an absorbing body (see Equation 3-1).

Equation 3-1
SAR Mathematical Equation

$$SAR = \frac{d}{dt} \left(\frac{dU}{dm} \right) = \frac{d}{dt} \left(\frac{dU}{\rho dv} \right)$$



SAR is expressed in units of Watts per Kilogram (W/kg).

$$SAR = \frac{\sigma \cdot E^2}{\rho}$$

where:

- σ = conductivity of the tissue-simulating material (S/m)
- ρ = mass density of the tissue-simulating material (kg/m³)
- E = Total RMS electric field strength (V/m)

NOTE: The primary factors that control rate of energy absorption were found to be the wavelength of the incident field in relation to the dimensions and geometry of the irradiated organism, the orientation of the organism in relation to the polarity of field vectors, the presence of reflecting surfaces, and whether conductive contact is made by the organism with a ground plane.[6]

FCC ID: ZNFV495	 PCTEST ENGINEERING LABORATORY, INC.	SAR EVALUATION REPORT		Reviewed by: Quality Manager
Document S/N: 0Y1503160550.ZNF	Test Dates: 03/16/15 - 03/25/15	DUT Type: Portable Tablet	Page 9 of 70	

4 DOSIMETRIC ASSESSMENT

4.1 Measurement Procedure

The evaluation was performed using the following procedure compliant to FCC KDB Publication 865664 D01v01 and IEEE 1528-2013:

1. The SAR distribution at the exposed side of the head or body was measured at a distance no greater than 5.0 mm from the inner surface of the shell. The area covered the entire dimension of the device-head and body interface and the horizontal grid resolution was determined per FCC KDB Publication 865664 D01v01 (See Table 4-1) and IEEE 1528-2013.
2. The point SAR measurement was taken at the maximum SAR region determined from Step 1 to enable the monitoring of SAR fluctuations/drifts during the 1g/10g cube evaluation. SAR at this fixed point was measured and used as a reference value.
3. Based on the area scan data, the peak of the region with maximum SAR was determined by spline interpolation. Around this point, a volume was assessed according to the measurement resolution and volume size requirements of FCC KDB Publication 865664 D01v01 (See Table 4-1) and IEEE 1528-2013. On the basis of this data set, the spatial peak SAR value was evaluated with the following procedure (see references or the DASy manual online for more details):
 - a. SAR values at the inner surface of the phantom are extrapolated from the measured values along the line away from the surface with spacing no greater than that in Table 4-1. The extrapolation was based on a least-squares algorithm. A polynomial of the fourth order was calculated through the points in the z-axis (normal to the phantom shell).
 - b. After the maximum interpolated values were calculated between the points in the cube, the SAR was averaged over the spatial volume (1g or 10g) using a 3D-Spline interpolation algorithm. The 3D-spline is composed of three one-dimensional splines with the “Not a knot” condition (in x, y, and z directions). The volume was then integrated with the trapezoidal algorithm. One thousand points (10 x 10 x 10) were obtained through interpolation, in order to calculate the averaged SAR.
 - c. All neighboring volumes were evaluated until no neighboring volume with a higher average value was found.
4. The SAR reference value, at the same location as step 2, was re-measured after the zoom scan was complete to calculate the SAR drift. If the drift deviated by more than 5%, the SAR test and drift measurements were repeated.

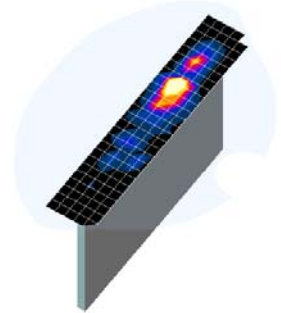



Figure 4-1
Sample SAR Area Scan

Table 4-1
Area and Zoom Scan Resolutions per FCC KDB Publication 865664 D01v01*

Frequency	Maximum Area Scan Resolution (mm) ($\Delta x_{\text{area}}, \Delta y_{\text{area}}$)	Maximum Zoom Scan Resolution (mm) ($\Delta x_{\text{zoom}}, \Delta y_{\text{zoom}}$)	Maximum Zoom Scan Spatial Resolution (mm)			Minimum Zoom Scan Volume (mm) (x, y, z)
			Uniform Grid	Graded Grid		
			$\Delta z_{\text{zoom}}(n)$	$\Delta z_{\text{zoom}}(1)^*$	$\Delta z_{\text{zoom}}(n>1)^*$	
≤ 2 GHz	≤ 15	≤ 8	≤ 5	≤ 4	≤ 1.5* $\Delta z_{\text{zoom}}(n-1)$	≥ 30
2-3 GHz	≤ 12	≤ 5	≤ 5	≤ 4	≤ 1.5* $\Delta z_{\text{zoom}}(n-1)$	≥ 30
3-4 GHz	≤ 12	≤ 5	≤ 4	≤ 3	≤ 1.5* $\Delta z_{\text{zoom}}(n-1)$	≥ 28
4-5 GHz	≤ 10	≤ 4	≤ 3	≤ 2.5	≤ 1.5* $\Delta z_{\text{zoom}}(n-1)$	≥ 25
5-6 GHz	≤ 10	≤ 4	≤ 2	≤ 2	≤ 1.5* $\Delta z_{\text{zoom}}(n-1)$	≥ 22

*Also compliant to IEEE 1528-2013 Table 6

FCC ID: ZNFV495	 PCTEST ENGINEERING LABORATORY, INC.	SAR EVALUATION REPORT			Reviewed by: Quality Manager
Document S/N: OY1503160550.ZNF	Test Dates: 03/16/15 - 03/25/15	DUT Type: Portable Tablet			Page 10 of 70

5 SAR TESTING PROCEDURES

5.1 SAR Testing for Tablet per KDB Publication 616217 D04v01

This device can be used also in full sized tablet exposure conditions, due to its size. Per FCC KDB 616217, the back surface and edges of the tablet should be tested for SAR compliance with the tablet touching the phantom. The SAR Exclusion Threshold in KDB 447498 D01v05 can be applied to determine SAR test exclusion for adjacent edge configurations. The closest distance from the antenna to an adjacent tablet edge is used to determine if SAR testing is required for the adjacent edges, with the adjacent edge positioned against the phantom and the edge containing the antenna positioned perpendicular to the phantom.



5.2 Proximity Sensor Considerations

This device uses a proximity sensor to reduce data powers in tablet-device use conditions.

While the device's antenna is within a certain distance of the user, the sensor activates and reduces the maximum output power allowed. However, the sensor is not active when the device is moved beyond the sensor triggering distance and the maximum output power is no longer limited. Therefore, an additional exposure condition is needed in the vicinity of the triggering distance to ensure SAR is compliant when the device is allowed to operate at a non-reduced output power level.

FCC KDB 616217 D04 Section 6 was used as a guideline for selecting SAR test distances for this device at these additional exposure conditions. Since the sensor activation distance for the back side of the device is 23 mm, a conservative distance of 22 mm was tested for SAR on the back side at maximum power. Since the sensor activation distance for the top edge of the device is 20 mm, a conservative distance of 19 mm was tested for SAR on the top edge at maximum power. Since the sensor activation distance for the right edge of the device is 8 mm, a conservative distance of 7 mm was tested for SAR on the right edge at maximum power. Sensor triggering distance summary data is included in Appendix G. The sensor does not trigger power reduction from the front of the device.

The sensor is designed to support sufficient detection range and sensitivity to cover regions of the sensors in all applicable directions since the sensor entirely covers the antenna.

FCC ID: ZNFV495	 PCTEST ENGINEERING LABORATORY, INC.	SAR EVALUATION REPORT		Reviewed by: Quality Manager
Document S/N: 0Y1503160550.ZNF	Test Dates: 03/16/15 - 03/25/15	DUT Type: Portable Tablet	Page 11 of 70	

6 RF EXPOSURE LIMITS

6.1 Uncontrolled Environment

UNCONTROLLED ENVIRONMENTS are defined as locations where there is the exposure of individuals who have no knowledge or control of their exposure. The general population/uncontrolled exposure limits are applicable to situations in which the general public may be exposed or in which persons who are exposed as a consequence of their employment may not be made fully aware of the potential for exposure or cannot exercise control over their exposure. Members of the general public would come under this category when exposure is not employment-related; for example, in the case of a wireless transmitter that exposes persons in its vicinity.



6.2 Controlled Environment

CONTROLLED ENVIRONMENTS are defined as locations where there is exposure that may be incurred by persons who are aware of the potential for exposure, (i.e. as a result of employment or occupation). In general, occupational/controlled exposure limits are applicable to situations in which persons are exposed as a consequence of their employment, who have been made fully aware of the potential for exposure and can exercise control over their exposure. This exposure category is also applicable when the exposure is of a transient nature due to incidental passage through a location where the exposure levels may be higher than the general population/uncontrolled limits, but the exposed person is fully aware of the potential for exposure and can exercise control over his or her exposure by leaving the area or by some other appropriate means.

Table 6-1
SAR Human Exposure Specified in ANSI/IEEE C95.1-1992 and Health Canada Safety Code 6

HUMAN EXPOSURE LIMITS		
	UNCONTROLLED ENVIRONMENT <i>General Population</i> (W/kg) or (mW/g)	CONTROLLED ENVIRONMENT <i>Occupational</i> (W/kg) or (mW/g)
Peak Spatial Average SAR Head	1.6	8.0
Whole Body SAR	0.08	0.4
Peak Spatial Average SAR Hands, Feet, Ankle, Wrists, etc.	4.0	20

1. The Spatial Peak value of the SAR averaged over any 1 gram of tissue (defined as a tissue volume in the shape of a cube) and over the appropriate averaging time.
2. The Spatial Average value of the SAR averaged over the whole body.
3. The Spatial Peak value of the SAR averaged over any 10 grams of tissue (defined as a tissue volume in the shape of a cube) and over the appropriate averaging time.

FCC ID: ZNFV495	 PCTEST ENGINEERING LABORATORY, INC.	SAR EVALUATION REPORT		Reviewed by: Quality Manager
Document S/N: OY1503160550.ZNF	Test Dates: 03/16/15 - 03/25/15	DUT Type: Portable Tablet		Page 12 of 70

7 FCC MEASUREMENT PROCEDURES

Power measurements were performed using a base station simulator under digital average power.

7.1 Measured and Reported SAR

Per FCC KDB Publication 447498 D01v05, When SAR is not measured at the maximum power level allowed for production units, the results must be scaled to the maximum tune-up tolerance limit according to the power applied to the individual channels tested to determine compliance. For simultaneous transmission, the measured aggregate SAR must be scaled according to the sum of the differences between the maximum tune-up tolerance and actual power used to test each transmitter. When SAR is measured at or scaled to the maximum tune-up tolerance limit, the results are referred to as *reported SAR*. The highest *reported SAR* results are identified on the grant of equipment authorization according to procedures in KDB 690783 D01v01r02

7.2 3G SAR Test Reduction Procedure

In FCC KDB Publication 941225 D01v03, certain transmission modes within a frequency band and wireless mode evaluated for SAR are defined as primary modes. The equivalent modes considered for SAR test reduction are denoted as secondary modes. When the maximum output power including tune-up tolerance specified for production units in a secondary mode is ≤ 0.25 dB higher than the primary mode or when the highest reported SAR of the primary mode, scaled by the ratio of specified maximum output power and tune-up tolerance of secondary to primary mode, is ≤ 1.2 W/kg, SAR measurements are not required for the secondary mode. These criteria are referred to as the 3G SAR test reduction procedure. When the 3G SAR test reduction procedure is not satisfied, SAR measurements are additionally required for the secondary mode.

7.3 Procedures Used to Establish RF Signal for SAR



The following procedures are according to FCC KDB Publication 941225 D01v03 "SAR Measurement Procedures for 3G Devices" v02, October 2007.

The device was placed into a simulated call using a base station simulator in a RF shielded chamber. Establishing connections in this manner ensure a consistent means for testing SAR and are recommended for evaluating SAR [4]. Devices under test were evaluated prior to testing, with a fully charged battery and were configured to operate at maximum output power. In order to verify that the device was tested throughout the SAR test at maximum output power, the SAR measurement system measures a "point SAR" at an arbitrary reference point at the start and end of the 1 gram SAR evaluation, to assess for any power drifts during the evaluation. If the power drift deviated by more than 5%, the SAR test and drift measurements were repeated.

7.1 SAR Measurement Conditions for UMTS

7.1.1 Output Power Verification

Maximum output power is verified on the High, Middle and Low channels according to the general descriptions in section 5.2 of 3GPP TS 34.121, using the appropriate RMC with TPC (transmit power control) set to all "1s" or applying the required inner loop power control procedures to maintain maximum output power while HSUPA is active. Results for all applicable physical channel configurations (DPCCH, DPDCHn and spreading codes, HS-DPCCH etc) are tabulated in this test report. All configurations that are not supported by the DUT or cannot be measured due to technical or equipment limitations are identified.

FCC ID: ZNFV495	 PCTEST ENGINEERING LABORATORY, INC.	SAR EVALUATION REPORT		Reviewed by: Quality Manager
Document S/N: OY1503160550.ZNF	Test Dates: 03/16/15 - 03/25/15	DUT Type: Portable Tablet		Page 13 of 70

7.1.2 Body SAR Measurements

SAR for body exposure configurations is measured using the 12.2 kbps RMC with the TPC bits all “1s”. The 3G SAR test reduction procedure is applied to other spreading codes and multiple DPDCH_n configurations supported by the handset with 12.2 kbps RMC as the primary mode. Otherwise, SAR is measured using an applicable RMC configuration with the corresponding spreading code or DPDCH_n, for the highest reported SAR configuration in 12.2 kbps RMC.

7.1.3 SAR Measurements for Data Devices with Rel 5 HSDPA

The 3G SAR test reduction procedure is applied to HSDPA body configurations with 12.2 kbps RMC as the primary mode. Otherwise, Body SAR for HSDPA is measured using an FRC with H-Set 1 in Sub-test 1 and a 12.2 kbps RMC configured in Test Loop Mode 1, for the highest reported SAR configuration in 12.2 kbps RMC without HSDPA. Handsets with both HSDPA and HSUPA are tested according to Release 6 HSPA test procedures.

7.1.4 SAR Measurements for Data Devices with Rel 6 HSUPA

The 3G SAR test reduction procedure is applied to HSPA (HSUPA/HSDPA with RMC) body configurations with 12.2 kbps RMC as the primary mode. Otherwise, Body SAR for HSPA is measured with E-DCH Sub-test 5, using H-Set 1 and QPSK for FRC and a 12.2 kbps RMC configured in Test Loop Mode 1 and power control algorithm 2, according to the highest reported body SAR configuration in 12.2 kbps RMC without HSPA.

7.1.1 SAR Measurement Conditions for DC-HSDPA

SAR test exclusion for DC-HSDPA devices is determined by power measurements according to the H-Set 12, Fixed Reference Channel (FRC) configuration in Table C.8.1.12 of 3GPP TS 34.121-1. A primary and a secondary serving HS-DSCH Cell are required to perform the power measurement and for the results to qualify for SAR test exclusion. DC-HSDPA uplink maximum output power measurements using the four Rel. 5 HSDPA subtests in Table C.10.1.4 of TS 234.121-1 is required.

7.2 SAR Measurement Conditions for LTE

LTE modes were tested according to FCC KDB 941225 D05v02r03 publication. Please see notes after the tabulated SAR data for required test configurations. Establishing connections with base station simulators ensure a consistent means for testing SAR and are recommended for evaluating SAR [4]. The R&S CMW500 was used for LTE output power measurements and SAR testing. Closed loop power control was used so the UE transmits with maximum output power during SAR testing. SAR tests were performed with the same number of RB and RB offsets transmitting on all TTI frames (maximum TTI).

7.2.1 Spectrum Plots for RB Configurations



A properly configured base station simulator was used for SAR tests and power measurements. Therefore, spectrum plots for RB configurations were not required to be included in this report.

7.2.2 MPR

MPR is permanently implemented for this device by the manufacturer. The specific manufacturer target MPR is indicated alongside the SAR results. MPR is enabled for this device, according to 3GPP TS36.101 Section 6.2.3 – 6.2.5 under Table 6.2.3-1.

7.2.3 A-MPR

A-MPR (Additional MPR) has been disabled for all SAR tests by setting NS=01 on the base station simulator.

FCC ID: ZNFV495	 PCTEST ENGINEERING LABORATORY, INC.	SAR EVALUATION REPORT		Reviewed by: Quality Manager
Document S/N: OY1503160550.ZNF	Test Dates: 03/16/15 - 03/25/15	DUT Type: Portable Tablet		Page 14 of 70

7.2.4 Required RB Size and RB Offsets for SAR Testing

According to FCC KDB 941225 D05v02r03:



- a. Per Section 4.2.1, SAR is required for QPSK 1 RB Allocation for the largest bandwidth
 - i. The required channel and offset combination with the highest maximum output power is required for SAR.
 - ii. When the reported SAR is ≤ 0.8 W/kg, testing of the remaining RB offset configurations and required test channels is not required. Otherwise, SAR is required for the remaining required test channels using the RB offset configuration with highest output power for that channel.
 - iii. When the reported SAR for a required test channel is > 1.45 W/kg, SAR is required for all RB offset configurations for that channel.
- b. Per Section 4.2.2, SAR is required for 50% RB allocation using the largest bandwidth following the same procedures outlined in Section 4.2.1.
- c. Per Section 4.2.3, QPSK SAR is not required for the 100% allocation when the highest maximum output power for the 100% allocation is less than the highest maximum output power of the 1 RB and 50% RB allocations and the reported SAR for the 1 RB and 50% RB allocations is < 0.8 W/kg.
- d. Per Section 4.2.4 and 4.3, SAR tests for higher order modulations and lower bandwidths configurations are not required when the conducted power of the required test configurations determined by Sections 4.2.1 through 4.2.3 is less than or equal to $\frac{1}{2}$ dB higher than the equivalent configuration using QPSK modulation and when the QPSK SAR for those configurations is < 1.45 W/kg.

7.2.5 Carrier Aggregation

LTE Carrier Aggregation (CA) measurements were made in accordance to 3GPP TS 36.521-1 V10.4.0 (2012-12). The RRC connection is only handled by one cell, the Primary component carrier (PCC) for downlink and uplink communications. After making a data connection to the PCC, the UE device adds the Secondary component carrier (SCC) on the downlink only. All uplink communications and acknowledgements remain identical to release 8 specifications on the PCC. Additional output powers were measured using two carriers in the downlink for the release 8 configurations with the highest output power among all channels, RB configurations and bandwidths for each uplink band. Per FCC Guidance, no SAR measurements were required.

7.3 SAR Testing with 802.11 Transmitters

Normal network operating configurations are not suitable for measuring the SAR of 802.11 a/b/g/n transmitters. Unpredictable fluctuations in network traffic and antenna diversity conditions can introduce undesirable variations in SAR results. The SAR for these devices should be measured using chipset based test mode software to ensure the results are consistent and reliable. See KDB Publication 248227 D01v01r02 for more details.

FCC ID: ZNFV495	 PCTEST ENGINEERING LABORATORY, INC.	SAR EVALUATION REPORT		Reviewed by: Quality Manager
Document S/N: OY1503160550.ZNF	Test Dates: 03/16/15 - 03/25/15	DUT Type: Portable Tablet	Page 15 of 70	

7.3.1 General Device Setup



Chipset based test mode software is hardware dependent and generally varies among manufacturers. The device operating parameters established in test mode for SAR measurements must be identical to those programmed in production units, including output power levels, amplifier gain settings and other RF performance tuning parameters. The test frequencies should correspond to actual channel frequencies defined for domestic use. SAR for devices with switched diversity should be measured with only one antenna transmitting at a time during each SAR measurement, according to a fixed modulation and data rate. The same data pattern should be used for all measurements.

7.3.2 Frequency Channel Configurations [24]

For 2.4 GHz, the highest average RF output power channel between the low, mid and high channel at the lowest data rate was selected for SAR evaluation in 802.11b mode. 802.11g/n modes and higher data rates for 802.11b were additionally evaluated for SAR if the output power of the respective mode was 0.25 dB or higher than the powers of the SAR configurations tested in the 802.11b mode.

For 5 GHz, the highest average RF output power channel across the default test channels at the lowest data rate was selected for SAR evaluation in 802.11a. When the adjacent channels are higher in power than the default channels, these “required channels” were considered instead of the default channels for SAR testing. 802.11n modes and higher data rates for 802.11a/n were evaluated only if the respective mode was higher than 0.25 dB or more than the 802.11a mode.

If the maximum extrapolated peak SAR of the zoom scan for the highest output channel was less than 1.6 W/kg and if the 1g averaged SAR was less than 0.8 W/kg, SAR testing was not required for the other test channels in the band.

FCC ID: ZNFV495	 PCTEST ENGINEERING LABORATORY, INC.	SAR EVALUATION REPORT	 LG	Reviewed by: Quality Manager
Document S/N: 0Y1503160550.ZNF	Test Dates: 03/16/15 - 03/25/15	DUT Type: Portable Tablet	Page 16 of 70	

8 RF CONDUCTED POWERS

8.1 UMTS Conducted Powers

**Table 8-1
Maximum Average RF Output Powers**

3GPP Release Version	Mode	3GPP 34.121 Subtest	Cellular Band [dBm]			AWS Band [dBm]			PCS Band [dBm]			3GPP MPR [dB]
			4132	4183	4233	1312	1412	1862	9262	9400	9538	
99	WCDMA	12.2 kbps RMC	24.68	24.64	24.65	24.07	24.11	24.19	23.60	23.65	23.61	-
6	HSDPA	Subtest 1	24.61	24.68	24.64	23.91	24.02	24.10	23.28	23.32	23.37	0
6		Subtest 2	24.67	24.65	24.64	24.00	24.01	24.07	23.25	23.34	23.23	0
6		Subtest 3	24.11	24.05	24.01	23.25	23.31	23.43	23.00	22.76	22.90	0.5
6		Subtest 4	24.07	24.16	24.09	23.42	23.37	23.49	23.02	22.79	22.83	0.5
6	HSUPA	Subtest 1	24.59	24.61	24.68	24.04	24.00	24.17	23.30	23.35	23.39	0
6		Subtest 2	23.45	23.49	23.56	23.12	23.07	23.18	22.17	22.20	22.15	2
6		Subtest 3	23.80	23.82	23.78	23.19	23.20	23.26	22.24	22.29	22.26	1
6		Subtest 4	23.50	23.53	23.44	23.06	23.10	23.15	22.09	22.07	22.12	2
6		Subtest 5	24.65	24.69	24.60	23.97	24.08	24.03	23.36	23.27	23.32	0
8	DC-HSDPA	Subtest 1	24.60	24.63	24.66	23.98	23.99	24.05	23.46	23.42	23.51	0
8		Subtest 2	24.62	24.67	24.59	24.10	24.03	24.12	23.27	23.30	23.29	0
8		Subtest 3	24.15	24.07	24.11	23.36	23.41	23.40	22.96	22.98	22.87	0.5
8		Subtest 4	24.09	24.17	24.04	23.52	23.39	23.47	22.76	22.74	22.81	0.5

**Table 8-2
Reduced Average RF Output Powers – Body at 0.0 cm**

3GPP Release Version	Mode	3GPP 34.121 Subtest	Cellular Band [dBm]			AWS Band [dBm]			PCS Band [dBm]			3GPP MPR [dB]
			4132	4183	4233	1312	1412	1862	9262	9400	9538	
99	WCDMA	12.2 kbps RMC	20.42	20.50	20.50	12.73	12.90	12.80	12.33	12.39	12.42	-
6	HSDPA	Subtest 1	20.60	20.52	20.59	13.03	12.90	12.98	12.68	12.53	12.50	0
6		Subtest 2	20.64	20.67	20.62	12.93	12.85	12.92	12.49	12.57	12.59	0
6		Subtest 3	20.52	20.50	20.53	12.99	12.82	12.87	12.40	12.47	12.46	0.5
6		Subtest 4	20.53	20.56	20.51	12.97	12.83	12.86	12.49	12.50	12.48	0.5
6	HSUPA	Subtest 1	20.41	20.65	20.47	12.95	12.99	12.97	12.64	12.59	12.61	0
6		Subtest 2	19.51	19.63	19.57	11.84	11.79	11.82	11.69	11.75	11.70	2
6		Subtest 3	19.84	19.91	19.74	12.02	12.10	12.13	11.99	12.06	12.15	1
6		Subtest 4	19.52	19.56	19.53	11.86	11.85	11.90	11.67	11.62	11.73	2
6		Subtest 5	20.49	20.63	20.56	12.97	12.89	12.94	12.70	12.56	12.64	0
8	DC-HSDPA	Subtest 1	20.60	20.57	20.63	13.07	13.04	12.98	12.66	12.58	12.53	0
8		Subtest 2	20.56	20.55	20.61	12.96	12.97	13.00	12.60	12.49	12.49	0
8		Subtest 3	20.48	20.42	20.51	12.95	12.92	12.94	12.56	12.41	12.42	0.5
8		Subtest 4	20.45	20.44	20.50	12.92	12.91	12.97	12.47	12.43	12.46	0.5

DC-HSDPA considerations

- 3GPP TS 34.121-1 was used for DC-HSDPA guidance
- 3G SAR test reduction procedure is applied to DC-HSDPA with 12.2 kbps RMC as the primary mode
- H-Set 12 (QPSK) was confirmed to be used during DC-HSDPA measurements
- The DUT supports UE category 24 for HSDPA.

It is expected by the manufacturer that MPR for some HSPA subtests may be up to 1 dB more than specified by 3GPP, but also as low as 0 dB according to the chipset implementation in this model.



**Figure 8-1
Power Measurement Setup**

FCC ID: ZNFV495	PCTEST ENGINEERING LABORATORY, INC.	SAR EVALUATION REPORT	LG	Reviewed by: Quality Manager
Document S/N: OY1503160550.ZNF	Test Dates: 03/16/15 - 03/25/15	DUT Type: Portable Tablet	Page 17 of 70	

8.2 LTE Conducted Powers

8.2.1 LTE Band 12

Table 8-3
LTE Band 12 Conducted Powers - 10 MHz Bandwidth

	Frequency [MHz]	Channel	Bandwidth [MHz]	Modulation	RB Size	RB Offset	Conducted Power [dBm]	MPR Allowed per 3GPP [dB]	MPR [dB]
Mid	707.5	23095	10	QPSK	1	0	24.42	0	0
	707.5	23095	10	QPSK	1	25	24.39	0	0
	707.5	23095	10	QPSK	1	49	24.40	0	0
	707.5	23095	10	QPSK	25	0	23.32	0-1	1
	707.5	23095	10	QPSK	25	12	23.24	0-1	1
	707.5	23095	10	QPSK	25	25	23.39	0-1	1
	707.5	23095	10	QPSK	50	0	23.34	0-1	1
	707.5	23095	10	16QAM	1	0	23.37	0-1	1
	707.5	23095	10	16QAM	1	25	23.39	0-1	1
	707.5	23095	10	16QAM	1	49	23.42	0-1	1
	707.5	23095	10	16QAM	25	0	22.25	0-2	2
	707.5	23095	10	16QAM	25	12	22.30	0-2	2
	707.5	23095	10	16QAM	25	25	22.29	0-2	2
	707.5	23095	10	16QAM	50	0	22.24	0-2	2

Note: LTE Band 12 at 10 MHz bandwidth does not support three non-overlapping channels. Per KDB Publication 941225 D05v02, when a device supports overlapping channel assignment in a channel bandwidth configuration, the middle channel of the group of overlapping channels should be selected for testing.

Table 8-4
LTE Band 12 Conducted Powers - 5 MHz Bandwidth

	Frequency [MHz]	Channel	Bandwidth [MHz]	Modulation	RB Size	RB Offset	Conducted Power [dBm]	MPR Allowed per 3GPP [dB]	MPR [dB]	
Low	701.5	23035	5	QPSK	1	0	24.58	0	0	
	701.5	23035	5	QPSK	1	12	24.65	0	0	
	701.5	23035	5	QPSK	1	24	24.70	0	0	
	701.5	23035	5	QPSK	12	0	23.34	0-1	1	
	701.5	23035	5	QPSK	12	6	23.37	0-1	1	
	701.5	23035	5	QPSK	12	13	23.31	0-1	1	
	701.5	23035	5	QPSK	25	0	23.32	0-1	1	
	701.5	23035	5	16-QAM	1	0	23.20	0-1	1	
	701.5	23035	5	16-QAM	1	12	23.23	0-1	1	
	701.5	23035	5	16-QAM	1	24	23.28	0-1	1	
	701.5	23035	5	16-QAM	12	0	22.23	0-2	2	
	701.5	23035	5	16-QAM	12	6	22.33	0-2	2	
	701.5	23035	5	16-QAM	12	13	22.28	0-2	2	
	701.5	23035	5	16-QAM	25	0	22.27	0-2	2	
	Mid	707.5	23095	5	QPSK	1	0	24.56	0	0
		707.5	23095	5	QPSK	1	12	24.63	0	0
		707.5	23095	5	QPSK	1	24	24.63	0	0
		707.5	23095	5	QPSK	12	0	23.37	0-1	1
		707.5	23095	5	QPSK	12	6	23.37	0-1	1
		707.5	23095	5	QPSK	12	13	23.47	0-1	1
707.5		23095	5	QPSK	25	0	23.40	0-1	1	
707.5		23095	5	16-QAM	1	0	23.20	0-1	1	
707.5		23095	5	16-QAM	1	12	23.27	0-1	1	
707.5		23095	5	16-QAM	1	24	23.34	0-1	1	
707.5		23095	5	16-QAM	12	0	22.28	0-2	2	
707.5		23095	5	16-QAM	12	6	22.26	0-2	2	
707.5		23095	5	16-QAM	12	13	22.38	0-2	2	
707.5		23095	5	16-QAM	25	0	22.29	0-2	2	
High		713.5	23155	5	QPSK	1	0	24.60	0	0
		713.5	23155	5	QPSK	1	12	24.65	0	0
		713.5	23155	5	QPSK	1	24	24.62	0	0
		713.5	23155	5	QPSK	12	0	23.37	0-1	1
		713.5	23155	5	QPSK	12	6	23.40	0-1	1
		713.5	23155	5	QPSK	12	13	23.46	0-1	1
	713.5	23155	5	QPSK	25	0	23.45	0-1	1	
	713.5	23155	5	16-QAM	1	0	23.20	0-1	1	
	713.5	23155	5	16-QAM	1	12	23.24	0-1	1	
	713.5	23155	5	16-QAM	1	24	23.34	0-1	1	
	713.5	23155	5	16-QAM	12	0	22.21	0-2	2	
	713.5	23155	5	16-QAM	12	6	22.29	0-2	2	
	713.5	23155	5	16-QAM	12	13	22.32	0-2	2	
	713.5	23155	5	16-QAM	25	0	22.35	0-2	2	



FCC ID: ZNFV495	 PCTEST ENGINEERING LABORATORY, INC.	SAR EVALUATION REPORT		Reviewed by: Quality Manager
Document S/N: OY1503160550.ZNF	Test Dates: 03/16/15 - 03/25/15	DUT Type: Portable Tablet		Page 18 of 70

Table 8-5
LTE Band 12 Conducted Powers - 3 MHz Bandwidth

	Frequency [MHz]	Channel	Bandwidth [MHz]	Modulation	RB Size	RB Offset	Conducted Power [dBm]	MPR Allowed per 3GPP [dB]	MPR [dB]
Low	700.5	23025	3	QPSK	1	0	24.61	0	0
	700.5	23025	3	QPSK	1	7	24.69	0	0
	700.5	23025	3	QPSK	1	14	24.61	0	0
	700.5	23025	3	QPSK	8	0	23.34	0-1	1
	700.5	23025	3	QPSK	8	4	23.38	0-1	1
	700.5	23025	3	QPSK	8	7	23.37	0-1	1
	700.5	23025	3	QPSK	15	0	23.49	0-1	1
	700.5	23025	3	16-QAM	1	0	23.05	0-1	1
	700.5	23025	3	16-QAM	1	7	23.42	0-1	1
	700.5	23025	3	16-QAM	1	14	23.40	0-1	1
	700.5	23025	3	16-QAM	8	0	22.43	0-2	2
	700.5	23025	3	16-QAM	8	4	22.16	0-2	2
	700.5	23025	3	16-QAM	8	7	22.42	0-2	2
	700.5	23025	3	16-QAM	15	0	22.28	0-2	2
	707.5	23095	3	QPSK	1	0	24.62	0	0
707.5	23095	3	QPSK	1	7	24.49	0	0	
707.5	23095	3	QPSK	1	14	24.60	0	0	
707.5	23095	3	QPSK	8	0	23.55	0-1	1	
707.5	23095	3	QPSK	8	4	23.55	0-1	1	
707.5	23095	3	QPSK	8	7	23.43	0-1	1	
707.5	23095	3	QPSK	15	0	23.30	0-1	1	
707.5	23095	3	16-QAM	1	0	23.20	0-1	1	
707.5	23095	3	16-QAM	1	7	23.26	0-1	1	
707.5	23095	3	16-QAM	1	14	23.16	0-1	1	
707.5	23095	3	16-QAM	8	0	22.38	0-2	2	
707.5	23095	3	16-QAM	8	4	22.35	0-2	2	
707.5	23095	3	16-QAM	8	7	22.57	0-2	2	
707.5	23095	3	16-QAM	15	0	22.30	0-2	2	
Mid	714.5	23165	3	QPSK	1	0	24.54	0	0
	714.5	23165	3	QPSK	1	7	24.53	0	0
	714.5	23165	3	QPSK	1	14	24.55	0	0
	714.5	23165	3	QPSK	8	0	23.22	0-1	1
	714.5	23165	3	QPSK	8	4	23.38	0-1	1
	714.5	23165	3	QPSK	8	7	23.33	0-1	1
	714.5	23165	3	QPSK	15	0	23.41	0-1	1
	714.5	23165	3	16-QAM	1	0	23.09	0-1	1
	714.5	23165	3	16-QAM	1	7	23.37	0-1	1
	714.5	23165	3	16-QAM	1	14	23.35	0-1	1
	714.5	23165	3	16-QAM	8	0	22.08	0-2	2
	714.5	23165	3	16-QAM	8	4	22.13	0-2	2
	714.5	23165	3	16-QAM	8	7	22.26	0-2	2
	714.5	23165	3	16-QAM	15	0	22.17	0-2	2
	High	714.5	23165	3	QPSK	1	0	24.54	0
714.5		23165	3	QPSK	1	7	24.53	0	0
714.5		23165	3	QPSK	1	14	24.55	0	0
714.5		23165	3	QPSK	8	0	23.22	0-1	1
714.5		23165	3	QPSK	8	4	23.38	0-1	1
714.5		23165	3	QPSK	8	7	23.33	0-1	1
714.5		23165	3	QPSK	15	0	23.41	0-1	1
714.5		23165	3	16-QAM	1	0	23.09	0-1	1
714.5		23165	3	16-QAM	1	7	23.37	0-1	1
714.5		23165	3	16-QAM	1	14	23.35	0-1	1
714.5		23165	3	16-QAM	8	0	22.08	0-2	2
714.5		23165	3	16-QAM	8	4	22.13	0-2	2
714.5		23165	3	16-QAM	8	7	22.26	0-2	2
714.5		23165	3	16-QAM	15	0	22.17	0-2	2

Table 8-6
LTE Band 12 Conducted Powers – 1.4 MHz Bandwidth

	Frequency [MHz]	Channel	Bandwidth [MHz]	Modulation	RB Size	RB Offset	Conducted Power [dBm]	MPR Allowed per 3GPP [dB]	MPR [dB]
Low	699.7	23017	1.4	QPSK	1	0	24.49	0	0
	699.7	23017	1.4	QPSK	1	2	24.47	0	0
	699.7	23017	1.4	QPSK	1	5	24.54	0	0
	699.7	23017	1.4	QPSK	3	0	24.58	0	0
	699.7	23017	1.4	QPSK	3	2	24.40	0	0
	699.7	23017	1.4	QPSK	3	3	24.48	0	0
	699.7	23017	1.4	QPSK	6	0	23.31	0-1	1
	699.7	23017	1.4	16-QAM	1	0	23.40	0-1	1
	699.7	23017	1.4	16-QAM	1	2	23.23	0-1	1
	699.7	23017	1.4	16-QAM	1	5	23.04	0-1	1
	699.7	23017	1.4	16-QAM	3	0	23.41	0-1	1
	699.7	23017	1.4	16-QAM	3	2	23.37	0-1	1
	699.7	23017	1.4	16-QAM	3	3	23.52	0-1	1
	699.7	23017	1.4	16-QAM	6	0	22.16	0-2	2
	707.5	23095	1.4	QPSK	1	0	24.54	0	0
707.5	23095	1.4	QPSK	1	2	24.55	0	0	
707.5	23095	1.4	QPSK	1	5	24.53	0	0	
707.5	23095	1.4	QPSK	3	0	24.47	0	0	
707.5	23095	1.4	QPSK	3	2	24.46	0	0	
707.5	23095	1.4	QPSK	3	3	24.45	0	0	
707.5	23095	1.4	QPSK	6	0	23.39	0-1	1	
707.5	23095	1.4	16-QAM	1	0	23.23	0-1	1	
707.5	23095	1.4	16-QAM	1	2	23.20	0-1	1	
707.5	23095	1.4	16-QAM	1	5	23.24	0-1	1	
707.5	23095	1.4	16-QAM	3	0	23.30	0-1	1	
707.5	23095	1.4	16-QAM	3	2	23.27	0-1	1	
707.5	23095	1.4	16-QAM	3	3	23.32	0-1	1	
707.5	23095	1.4	16-QAM	6	0	22.30	0-2	2	
Mid	715.3	23173	1.4	QPSK	1	0	24.52	0	0
	715.3	23173	1.4	QPSK	1	2	24.38	0	0
	715.3	23173	1.4	QPSK	1	5	24.69	0	0
	715.3	23173	1.4	QPSK	3	0	24.65	0	0
	715.3	23173	1.4	QPSK	3	2	24.38	0	0
	715.3	23173	1.4	QPSK	3	3	24.53	0	0
	715.3	23173	1.4	QPSK	6	0	23.40	0-1	1
	715.3	23173	1.4	16-QAM	1	0	23.04	0-1	1
	715.3	23173	1.4	16-QAM	1	2	23.31	0-1	1
	715.3	23173	1.4	16-QAM	1	5	23.41	0-1	1
	715.3	23173	1.4	16-QAM	3	0	23.19	0-1	1
	715.3	23173	1.4	16-QAM	3	2	23.14	0-1	1
	715.3	23173	1.4	16-QAM	3	3	23.35	0-1	1
	715.3	23173	1.4	16-QAM	6	0	22.10	0-2	2
	High	715.3	23173	1.4	QPSK	1	0	24.52	0
715.3		23173	1.4	QPSK	1	2	24.38	0	0
715.3		23173	1.4	QPSK	1	5	24.69	0	0
715.3		23173	1.4	QPSK	3	0	24.65	0	0
715.3		23173	1.4	QPSK	3	2	24.38	0	0
715.3		23173	1.4	QPSK	3	3	24.53	0	0
715.3		23173	1.4	QPSK	6	0	23.40	0-1	1
715.3		23173	1.4	16-QAM	1	0	23.04	0-1	1
715.3		23173	1.4	16-QAM	1	2	23.31	0-1	1
715.3		23173	1.4	16-QAM	1	5	23.41	0-1	1
715.3		23173	1.4	16-QAM	3	0	23.19	0-1	1
715.3		23173	1.4	16-QAM	3	2	23.14	0-1	1
715.3		23173	1.4	16-QAM	3	3	23.35	0-1	1
715.3		23173	1.4	16-QAM	6	0	22.10	0-2	2



FCC ID: ZNFV495	 PCTEST <small>ENGINEERING LABORATORY, INC.</small>	SAR EVALUATION REPORT		Reviewed by: Quality Manager
Document S/N: OY1503160550.ZNF	Test Dates: 03/16/15 - 03/25/15	DUT Type: Portable Tablet		Page 19 of 70

Table 8-7
LTE Band 12 Conducted Powers - 10 MHz Bandwidth
Reduced Power – Body at 0.0 cm

	Frequency [MHz]	Channel	Bandwidth [MHz]	Modulation	RB Size	RB Offset	Conducted Power [dBm]	MPR Allowed per 3GPP [dB]	MPR [dB]
Mid	707.5	23095	10	QPSK	1	0	20.49	0	0
	707.5	23095	10	QPSK	1	25	20.70	0	0
	707.5	23095	10	QPSK	1	49	20.62	0	0
	707.5	23095	10	QPSK	25	0	20.44	0-1	0
	707.5	23095	10	QPSK	25	12	20.57	0-1	0
	707.5	23095	10	QPSK	25	25	20.49	0-1	0
	707.5	23095	10	QPSK	50	0	20.45	0-1	0
	707.5	23095	10	16QAM	1	0	20.38	0-1	0
	707.5	23095	10	16QAM	1	25	20.63	0-1	0
	707.5	23095	10	16QAM	1	49	20.49	0-1	0
	707.5	23095	10	16QAM	25	0	20.50	0-2	0
	707.5	23095	10	16QAM	25	12	20.63	0-2	0
	707.5	23095	10	16QAM	25	25	20.52	0-2	0
707.5	23095	10	16QAM	50	0	20.44	0-2	0	

Note: LTE Band 12 at 10 MHz bandwidth does not support three non-overlapping channels. Per KDB Publication 941225 D05v02, when a device supports overlapping channel assignment in a channel bandwidth configuration, the middle channel of the group of overlapping channels should be selected for testing.

Table 8-8
LTE Band 12 Conducted Powers - 5 MHz Bandwidth
Reduced Power – Body at 0.0 cm

	Frequency [MHz]	Channel	Bandwidth [MHz]	Modulation	RB Size	RB Offset	Conducted Power [dBm]	MPR Allowed per 3GPP [dB]	MPR [dB]	
Low	701.5	23035	5	QPSK	1	0	20.32	0	0	
	701.5	23035	5	QPSK	1	12	20.36	0	0	
	701.5	23035	5	QPSK	1	24	20.39	0	0	
	701.5	23035	5	QPSK	12	0	20.45	0-1	0	
	701.5	23035	5	QPSK	12	6	20.51	0-1	0	
	701.5	23035	5	QPSK	12	13	20.42	0-1	0	
	701.5	23035	5	QPSK	25	0	20.37	0-1	0	
	701.5	23035	5	16-QAM	1	0	20.52	0-1	0	
	701.5	23035	5	16-QAM	1	12	20.40	0-1	0	
	701.5	23035	5	16-QAM	1	24	20.49	0-1	0	
	701.5	23035	5	16-QAM	12	0	20.22	0-2	0	
	701.5	23035	5	16-QAM	12	6	20.26	0-2	0	
	701.5	23035	5	16-QAM	12	13	20.27	0-2	0	
	701.5	23035	5	16-QAM	25	0	20.31	0-2	0	
	Mid	707.5	23095	5	QPSK	1	0	20.38	0	0
		707.5	23095	5	QPSK	1	12	20.25	0	0
707.5		23095	5	QPSK	1	24	20.39	0	0	
707.5		23095	5	QPSK	12	0	20.53	0-1	0	
707.5		23095	5	QPSK	12	6	20.42	0-1	0	
707.5		23095	5	QPSK	12	13	20.41	0-1	0	
707.5		23095	5	QPSK	25	0	20.42	0-1	0	
707.5		23095	5	16-QAM	1	0	20.23	0-1	0	
707.5		23095	5	16-QAM	1	12	20.28	0-1	0	
707.5		23095	5	16-QAM	1	24	20.21	0-1	0	
707.5		23095	5	16-QAM	12	0	20.30	0-2	0	
707.5		23095	5	16-QAM	12	6	20.56	0-2	0	
707.5		23095	5	16-QAM	12	13	20.37	0-2	0	
707.5		23095	5	16-QAM	25	0	20.42	0-2	0	
High		713.5	23155	5	QPSK	1	0	20.43	0	0
		713.5	23155	5	QPSK	1	12	20.34	0	0
	713.5	23155	5	QPSK	1	24	20.60	0	0	
	713.5	23155	5	QPSK	12	0	20.42	0-1	0	
	713.5	23155	5	QPSK	12	6	20.28	0-1	0	
	713.5	23155	5	QPSK	12	13	20.33	0-1	0	
	713.5	23155	5	QPSK	25	0	20.35	0-1	0	
	713.5	23155	5	16-QAM	1	0	20.61	0-1	0	
	713.5	23155	5	16-QAM	1	12	20.21	0-1	0	
	713.5	23155	5	16-QAM	1	24	20.26	0-1	0	
	713.5	23155	5	16-QAM	12	0	20.32	0-2	0	
	713.5	23155	5	16-QAM	12	6	20.57	0-2	0	
	713.5	23155	5	16-QAM	12	13	20.39	0-2	0	
	713.5	23155	5	16-QAM	25	0	20.44	0-2	0	





FCC ID: ZNFV495		SAR EVALUATION REPORT		Reviewed by: Quality Manager
Document S/N: OY1503160550.ZNF	Test Dates: 03/16/15 - 03/25/15	DUT Type: Portable Tablet		Page 20 of 70

Table 8-9
LTE Band 12 Conducted Powers - 3 MHz Bandwidth
Reduced Power – Body at 0.0 cm

	Frequency [MHz]	Channel	Bandwidth [MHz]	Modulation	RB Size	RB Offset	Conducted Power [dBm]	MPR Allowed per 3GPP [dB]	MPR [dB]
Low	700.5	23025	3	QPSK	1	0	20.27	0	0
	700.5	23025	3	QPSK	1	7	20.32	0	0
	700.5	23025	3	QPSK	1	14	20.46	0	0
	700.5	23025	3	QPSK	8	0	20.30	0-1	0
	700.5	23025	3	QPSK	8	4	20.37	0-1	0
	700.5	23025	3	QPSK	8	7	20.62	0-1	0
	700.5	23025	3	QPSK	15	0	20.36	0-1	0
	700.5	23025	3	16-QAM	1	0	20.37	0-1	0
	700.5	23025	3	16-QAM	1	7	20.32	0-1	0
	700.5	23025	3	16-QAM	1	14	20.38	0-1	0
	700.5	23025	3	16-QAM	8	0	20.56	0-2	0
	700.5	23025	3	16-QAM	8	4	20.44	0-2	0
	700.5	23025	3	16-QAM	8	7	20.41	0-2	0
	700.5	23025	3	16-QAM	15	0	20.43	0-2	0
	700.5	23025	3	16-QAM	15	0	20.43	0-2	0
Mid	707.5	23095	3	QPSK	1	0	20.40	0	0
	707.5	23095	3	QPSK	1	7	20.46	0	0
	707.5	23095	3	QPSK	1	14	20.38	0	0
	707.5	23095	3	QPSK	8	0	20.37	0-1	0
	707.5	23095	3	QPSK	8	4	20.36	0-1	0
	707.5	23095	3	QPSK	8	7	20.53	0-1	0
	707.5	23095	3	QPSK	15	0	20.40	0-1	0
	707.5	23095	3	16-QAM	1	0	20.48	0-1	0
	707.5	23095	3	16-QAM	1	7	20.45	0-1	0
	707.5	23095	3	16-QAM	1	14	20.41	0-1	0
	707.5	23095	3	16-QAM	8	0	20.54	0-2	0
	707.5	23095	3	16-QAM	8	4	20.34	0-2	0
	707.5	23095	3	16-QAM	8	7	20.36	0-2	0
	707.5	23095	3	16-QAM	15	0	20.31	0-2	0
	707.5	23095	3	16-QAM	15	0	20.31	0-2	0
High	714.5	23165	3	QPSK	1	0	20.39	0	0
	714.5	23165	3	QPSK	1	7	20.61	0	0
	714.5	23165	3	QPSK	1	14	20.47	0	0
	714.5	23165	3	QPSK	8	0	20.45	0-1	0
	714.5	23165	3	QPSK	8	4	20.46	0-1	0
	714.5	23165	3	QPSK	8	7	20.40	0-1	0
	714.5	23165	3	QPSK	15	0	20.41	0-1	0
	714.5	23165	3	16-QAM	1	0	20.39	0-1	0
	714.5	23165	3	16-QAM	1	7	20.50	0-1	0
	714.5	23165	3	16-QAM	1	14	20.52	0-1	0
	714.5	23165	3	16-QAM	8	0	20.34	0-2	0
	714.5	23165	3	16-QAM	8	4	20.29	0-2	0
	714.5	23165	3	16-QAM	8	7	20.22	0-2	0
	714.5	23165	3	16-QAM	15	0	20.30	0-2	0
	714.5	23165	3	16-QAM	15	0	20.30	0-2	0

Table 8-10
LTE Band 12 Conducted Powers – 1.4 MHz Bandwidth
Reduced Power – Body at 0.0 cm

	Frequency [MHz]	Channel	Bandwidth [MHz]	Modulation	RB Size	RB Offset	Conducted Power [dBm]	MPR Allowed per 3GPP [dB]	MPR [dB]
Low	699.7	23017	1.4	QPSK	1	0	20.30	0	0
	699.7	23017	1.4	QPSK	1	2	20.35	0	0
	699.7	23017	1.4	QPSK	1	5	20.37	0	0
	699.7	23017	1.4	QPSK	3	0	20.65	0	0
	699.7	23017	1.4	QPSK	3	2	20.45	0	0
	699.7	23017	1.4	QPSK	3	3	20.29	0	0
	699.7	23017	1.4	QPSK	6	0	20.32	0-1	0
	699.7	23017	1.4	16-QAM	1	0	20.47	0-1	0
	699.7	23017	1.4	16-QAM	1	2	20.45	0-1	0
	699.7	23017	1.4	16-QAM	1	5	20.40	0-1	0
	699.7	23017	1.4	16-QAM	3	0	20.54	0-1	0
	699.7	23017	1.4	16-QAM	3	2	20.36	0-1	0
	699.7	23017	1.4	16-QAM	3	3	20.38	0-1	0
	699.7	23017	1.4	16-QAM	6	0	20.31	0-2	0
	699.7	23017	1.4	16-QAM	6	0	20.31	0-2	0
Mid	707.5	23095	1.4	QPSK	1	0	20.49	0	0
	707.5	23095	1.4	QPSK	1	2	20.48	0	0
	707.5	23095	1.4	QPSK	1	5	20.51	0	0
	707.5	23095	1.4	QPSK	3	0	20.45	0	0
	707.5	23095	1.4	QPSK	3	2	20.37	0	0
	707.5	23095	1.4	QPSK	3	3	20.36	0	0
	707.5	23095	1.4	QPSK	6	0	20.36	0-1	0
	707.5	23095	1.4	16-QAM	1	0	20.32	0-1	0
	707.5	23095	1.4	16-QAM	1	2	20.39	0-1	0
	707.5	23095	1.4	16-QAM	1	5	20.40	0-1	0
	707.5	23095	1.4	16-QAM	3	0	20.43	0-1	0
	707.5	23095	1.4	16-QAM	3	2	20.58	0-1	0
	707.5	23095	1.4	16-QAM	3	3	20.31	0-1	0
	707.5	23095	1.4	16-QAM	6	0	20.27	0-2	0
	707.5	23095	1.4	16-QAM	6	0	20.27	0-2	0
High	715.3	23173	1.4	QPSK	1	0	20.39	0	0
	715.3	23173	1.4	QPSK	1	2	20.37	0	0
	715.3	23173	1.4	QPSK	1	5	20.45	0	0
	715.3	23173	1.4	QPSK	3	0	20.42	0	0
	715.3	23173	1.4	QPSK	3	2	20.40	0	0
	715.3	23173	1.4	QPSK	3	3	20.64	0	0
	715.3	23173	1.4	QPSK	6	0	20.39	0-1	0
	715.3	23173	1.4	16-QAM	1	0	20.42	0-1	0
	715.3	23173	1.4	16-QAM	1	2	20.59	0-1	0
	715.3	23173	1.4	16-QAM	1	5	20.32	0-1	0
	715.3	23173	1.4	16-QAM	3	0	20.35	0-1	0
	715.3	23173	1.4	16-QAM	3	2	20.36	0-1	0
	715.3	23173	1.4	16-QAM	3	3	20.33	0-1	0
	715.3	23173	1.4	16-QAM	6	0	20.37	0-2	0
	715.3	23173	1.4	16-QAM	6	0	20.37	0-2	0

FCC ID: ZNFV495		SAR EVALUATION REPORT		Reviewed by: Quality Manager
Document S/N: OY1503160550.ZNF	Test Dates: 03/16/15 - 03/25/15	DUT Type: Portable Tablet		Page 21 of 70

8.2.2 LTE Band 5 (Cell)

Table 8-11

LTE Band 5 (Cell) Conducted Powers - 10 MHz Bandwidth

	Frequency [MHz]	Channel	Bandwidth [MHz]	Modulation	RB Size	RB Offset	Conducted Power [dBm]	MPR Allowed per 3GPP [dB]	MPR [dB]
Mid	836.5	20525	10	QPSK	1	0	23.96	0	0
	836.5	20525	10	QPSK	1	25	24.02	0	0
	836.5	20525	10	QPSK	1	49	24.12	0	0
	836.5	20525	10	QPSK	25	0	22.90	0-1	1
	836.5	20525	10	QPSK	25	12	22.97	0-1	1
	836.5	20525	10	QPSK	25	25	22.86	0-1	1
	836.5	20525	10	QPSK	50	0	22.89	0-1	1
	836.5	20525	10	16QAM	1	0	22.77	0-1	1
	836.5	20525	10	16QAM	1	25	22.94	0-1	1
	836.5	20525	10	16QAM	1	49	22.87	0-1	1
	836.5	20525	10	16QAM	25	0	21.91	0-2	2
	836.5	20525	10	16QAM	25	12	21.98	0-2	2
	836.5	20525	10	16QAM	25	25	21.89	0-2	2
836.5	20525	10	16QAM	50	0	21.79	0-2	2	

Note: LTE Band 5 (Cell) at 10 MHz bandwidth does not support three non-overlapping channels. Per KDB Publication 941225 D05v02, when a device supports overlapping channel assignment in a channel bandwidth configuration, the middle channel of the group of overlapping channels should be selected for testing.

Table 8-12

LTE Band 5 (Cell) Conducted Powers - 5 MHz Bandwidth

	Frequency [MHz]	Channel	Bandwidth [MHz]	Modulation	RB Size	RB Offset	Conducted Power [dBm]	MPR Allowed per 3GPP [dB]	MPR [dB]
Low	826.5	20425	5	QPSK	1	0	23.93	0	0
	826.5	20425	5	QPSK	1	12	23.99	0	0
	826.5	20425	5	QPSK	1	24	23.98	0	0
	826.5	20425	5	QPSK	12	0	22.73	0-1	1
	826.5	20425	5	QPSK	12	6	22.65	0-1	1
	826.5	20425	5	QPSK	12	13	22.67	0-1	1
	826.5	20425	5	QPSK	25	0	22.75	0-1	1
	826.5	20425	5	16-QAM	1	0	22.79	0-1	1
	826.5	20425	5	16-QAM	1	12	22.53	0-1	1
	826.5	20425	5	16-QAM	1	24	22.49	0-1	1
	826.5	20425	5	16-QAM	12	0	21.61	0-2	2
	826.5	20425	5	16-QAM	12	6	21.62	0-2	2
	826.5	20425	5	16-QAM	12	13	21.65	0-2	2
	826.5	20425	5	16-QAM	25	0	21.69	0-2	2
	836.5	20525	5	QPSK	1	0	24.18	0	0
	836.5	20525	5	QPSK	1	12	24.20	0	0
	836.5	20525	5	QPSK	1	24	24.16	0	0
	836.5	20525	5	QPSK	12	0	22.95	0-1	1
	836.5	20525	5	QPSK	12	6	22.95	0-1	1
	836.5	20525	5	QPSK	12	13	22.90	0-1	1
836.5	20525	5	QPSK	25	0	22.99	0-1	1	
836.5	20525	5	16-QAM	1	0	22.75	0-1	1	
836.5	20525	5	16-QAM	1	12	22.81	0-1	1	
836.5	20525	5	16-QAM	1	24	22.70	0-1	1	
836.5	20525	5	16-QAM	12	0	21.66	0-2	2	
836.5	20525	5	16-QAM	12	6	21.64	0-2	2	
836.5	20525	5	16-QAM	12	13	21.64	0-2	2	
836.5	20525	5	16-QAM	25	0	21.87	0-2	2	
High	846.5	20625	5	QPSK	1	0	24.05	0	0
	846.5	20625	5	QPSK	1	12	23.94	0	0
	846.5	20625	5	QPSK	1	24	23.90	0	0
	846.5	20625	5	QPSK	12	0	22.77	0-1	1
	846.5	20625	5	QPSK	12	6	22.63	0-1	1
	846.5	20625	5	QPSK	12	13	22.61	0-1	1
	846.5	20625	5	QPSK	25	0	22.70	0-1	1
	846.5	20625	5	16-QAM	1	0	22.60	0-1	1
	846.5	20625	5	16-QAM	1	12	22.57	0-1	1
	846.5	20625	5	16-QAM	1	24	22.59	0-1	1
	846.5	20625	5	16-QAM	12	0	21.68	0-2	2
	846.5	20625	5	16-QAM	12	6	21.60	0-2	2
	846.5	20625	5	16-QAM	12	13	21.60	0-2	2
	846.5	20625	5	16-QAM	25	0	21.66	0-2	2



FCC ID: ZNFV495	 PCTEST ENGINEERING LABORATORY, INC.	SAR EVALUATION REPORT		Reviewed by: Quality Manager
Document S/N: OY1503160550.ZNF	Test Dates: 03/16/15 - 03/25/15	DUT Type: Portable Tablet	Page 22 of 70	

Table 8-13
LTE Band 5 (Cell) Conducted Powers - 3 MHz Bandwidth

	Frequency [MHz]	Channel	Bandwidth [MHz]	Modulation	RB Size	RB Offset	Conducted Power [dBm]	MPR Allowed per 3GPP [dB]	MPR [dB]
Low	825.5	20415	3	QPSK	1	0	23.76	0	0
	825.5	20415	3	QPSK	1	7	23.94	0	0
	825.5	20415	3	QPSK	1	14	23.99	0	0
	825.5	20415	3	QPSK	8	0	22.59	0-1	1
	825.5	20415	3	QPSK	8	4	22.68	0-1	1
	825.5	20415	3	QPSK	8	7	22.78	0-1	1
	825.5	20415	3	QPSK	15	0	22.89	0-1	1
	825.5	20415	3	16-QAM	1	0	22.95	0-1	1
	825.5	20415	3	16-QAM	1	7	22.31	0-1	1
	825.5	20415	3	16-QAM	1	14	22.62	0-1	1
	825.5	20415	3	16-QAM	8	0	21.68	0-2	2
	825.5	20415	3	16-QAM	8	4	21.82	0-2	2
	825.5	20415	3	16-QAM	8	7	21.59	0-2	2
	825.5	20415	3	16-QAM	15	0	21.97	0-2	2
	836.5	20525	3	QPSK	1	0	24.18	0	0
	836.5	20525	3	QPSK	1	7	23.90	0	0
	836.5	20525	3	QPSK	1	14	24.09	0	0
	836.5	20525	3	QPSK	8	0	23.17	0-1	1
836.5	20525	3	QPSK	8	4	22.69	0-1	1	
836.5	20525	3	QPSK	8	7	22.98	0-1	1	
836.5	20525	3	QPSK	15	0	22.91	0-1	1	
836.5	20525	3	16-QAM	1	0	22.89	0-1	1	
836.5	20525	3	16-QAM	1	7	22.59	0-1	1	
836.5	20525	3	16-QAM	1	14	22.75	0-1	1	
836.5	20525	3	16-QAM	8	0	21.69	0-2	2	
836.5	20525	3	16-QAM	8	4	21.90	0-2	2	
836.5	20525	3	16-QAM	8	7	22.03	0-2	2	
836.5	20525	3	16-QAM	15	0	21.60	0-2	2	
High	847.5	20635	3	QPSK	1	0	24.04	0	0
	847.5	20635	3	QPSK	1	7	23.94	0	0
	847.5	20635	3	QPSK	1	14	23.68	0	0
	847.5	20635	3	QPSK	8	0	22.97	0-1	1
	847.5	20635	3	QPSK	8	4	22.87	0-1	1
	847.5	20635	3	QPSK	8	7	22.65	0-1	1
	847.5	20635	3	QPSK	15	0	22.98	0-1	1
	847.5	20635	3	16-QAM	1	0	22.77	0-1	1
	847.5	20635	3	16-QAM	1	7	22.57	0-1	1
	847.5	20635	3	16-QAM	1	14	22.49	0-1	1
	847.5	20635	3	16-QAM	8	0	21.66	0-2	2
	847.5	20635	3	16-QAM	8	4	21.57	0-2	2
	847.5	20635	3	16-QAM	8	7	21.62	0-2	2
	847.5	20635	3	16-QAM	15	0	21.69	0-2	2

Table 8-14
LTE Band 5 (Cell) Conducted Powers -1.4 MHz Bandwidth

	Frequency [MHz]	Channel	Bandwidth [MHz]	Modulation	RB Size	RB Offset	Conducted Power [dBm]	MPR Allowed per 3GPP [dB]	MPR [dB]
Low	824.7	20407	1.4	QPSK	1	0	23.89	0	0
	824.7	20407	1.4	QPSK	1	2	23.92	0	0
	824.7	20407	1.4	QPSK	1	5	24.14	0	0
	824.7	20407	1.4	QPSK	3	0	23.75	0	0
	824.7	20407	1.4	QPSK	3	2	23.54	0	0
	824.7	20407	1.4	QPSK	3	3	23.82	0	0
	824.7	20407	1.4	QPSK	6	0	22.97	0-1	1
	824.7	20407	1.4	16-QAM	1	0	23.03	0-1	1
	824.7	20407	1.4	16-QAM	1	2	22.37	0-1	1
	824.7	20407	1.4	16-QAM	1	5	22.57	0-1	1
	824.7	20407	1.4	16-QAM	3	0	22.59	0-1	1
	824.7	20407	1.4	16-QAM	3	2	22.91	0-1	1
	824.7	20407	1.4	16-QAM	3	3	22.60	0-1	1
	824.7	20407	1.4	16-QAM	6	0	22.00	0-2	2
	836.5	20525	1.4	QPSK	1	0	24.03	0	0
	836.5	20525	1.4	QPSK	1	2	23.80	0	0
	836.5	20525	1.4	QPSK	1	5	24.14	0	0
	836.5	20525	1.4	QPSK	3	0	24.02	0	0
836.5	20525	1.4	QPSK	3	2	23.76	0	0	
836.5	20525	1.4	QPSK	3	3	24.06	0	0	
836.5	20525	1.4	QPSK	6	0	22.86	0-1	1	
836.5	20525	1.4	16-QAM	1	0	22.75	0-1	1	
836.5	20525	1.4	16-QAM	1	2	22.59	0-1	1	
836.5	20525	1.4	16-QAM	1	5	22.79	0-1	1	
836.5	20525	1.4	16-QAM	3	0	22.78	0-1	1	
836.5	20525	1.4	16-QAM	3	2	23.01	0-1	1	
836.5	20525	1.4	16-QAM	3	3	23.20	0-1	1	
836.5	20525	1.4	16-QAM	6	0	21.63	0-2	2	
High	848.3	20643	1.4	QPSK	1	0	24.06	0	0
	848.3	20643	1.4	QPSK	1	2	23.93	0	0
	848.3	20643	1.4	QPSK	1	5	23.71	0	0
	848.3	20643	1.4	QPSK	3	0	23.94	0	0
	848.3	20643	1.4	QPSK	3	2	24.06	0	0
	848.3	20643	1.4	QPSK	3	3	23.61	0	0
	848.3	20643	1.4	QPSK	6	0	22.79	0-1	1
	848.3	20643	1.4	16-QAM	1	0	22.75	0-1	1
	848.3	20643	1.4	16-QAM	1	2	22.51	0-1	1
	848.3	20643	1.4	16-QAM	1	5	22.59	0-1	1
	848.3	20643	1.4	16-QAM	3	0	22.84	0-1	1
	848.3	20643	1.4	16-QAM	3	2	22.59	0-1	1
	848.3	20643	1.4	16-QAM	3	3	22.66	0-1	1
	848.3	20643	1.4	16-QAM	6	0	21.79	0-2	2

Table 8-15
LTE Band 5 (Cell) Conducted Powers – 10 MHz Bandwidth
Reduced Power – Body at 0.0 cm

	Frequency [MHz]	Channel	Bandwidth [MHz]	Modulation	RB Size	RB Offset	Conducted Power [dBm]	MPR Allowed per 3GPP [dB]	MPR [dB]
Mid	836.5	20525	10	QPSK	1	0	20.17	0	0
	836.5	20525	10	QPSK	1	25	20.18	0	0
	836.5	20525	10	QPSK	1	49	20.19	0	0
	836.5	20525	10	QPSK	25	0	19.99	0-1	0
	836.5	20525	10	QPSK	25	12	19.99	0-1	0
	836.5	20525	10	QPSK	25	25	20.05	0-1	0
	836.5	20525	10	QPSK	50	0	20.04	0-1	0
	836.5	20525	10	16QAM	1	0	20.14	0-1	0
	836.5	20525	10	16QAM	1	25	20.08	0-1	0
	836.5	20525	10	16QAM	1	49	20.14	0-1	0
	836.5	20525	10	16QAM	25	0	20.07	0-2	0
	836.5	20525	10	16QAM	25	12	20.10	0-2	0
	836.5	20525	10	16QAM	25	25	20.16	0-2	0
836.5	20525	10	16QAM	50	0	20.06	0-2	0	

Note: LTE Band 5 (Cell) at 10 MHz bandwidth does not support three non-overlapping channels. Per KDB Publication 941225 D05v02, when a device supports overlapping channel assignment in a channel bandwidth configuration, the middle channel of the group of overlapping channels should be selected for testing.

Table 8-16
LTE Band 5 (Cell) Conducted Powers – 5 MHz Bandwidth
Reduced Power – Body at 0.0 cm

	Frequency [MHz]	Channel	Bandwidth [MHz]	Modulation	RB Size	RB Offset	Conducted Power [dBm]	MPR Allowed per 3GPP [dB]	MPR [dB]
Low	826.5	20425	5	QPSK	1	0	19.94	0	0
	826.5	20425	5	QPSK	1	12	19.90	0	0
	826.5	20425	5	QPSK	1	24	19.91	0	0
	826.5	20425	5	QPSK	12	0	19.80	0-1	0
	826.5	20425	5	QPSK	12	6	19.81	0-1	0
	826.5	20425	5	QPSK	12	13	19.74	0-1	0
	826.5	20425	5	QPSK	25	0	19.83	0-1	0
	826.5	20425	5	16-QAM	1	0	19.80	0-1	0
	826.5	20425	5	16-QAM	1	12	19.83	0-1	0
	826.5	20425	5	16-QAM	1	24	19.84	0-1	0
	826.5	20425	5	16-QAM	12	0	19.76	0-2	0
	826.5	20425	5	16-QAM	12	6	19.77	0-2	0
	826.5	20425	5	16-QAM	12	13	19.70	0-2	0
	826.5	20425	5	16-QAM	25	0	19.88	0-2	0
	836.5	20525	5	QPSK	1	0	19.90	0	0
	836.5	20525	5	QPSK	1	12	19.91	0	0
	836.5	20525	5	QPSK	1	24	19.92	0	0
	836.5	20525	5	QPSK	12	0	19.75	0-1	0
836.5	20525	5	QPSK	12	6	19.79	0-1	0	
836.5	20525	5	QPSK	12	13	19.76	0-1	0	
836.5	20525	5	QPSK	25	0	19.78	0-1	0	
836.5	20525	5	16-QAM	1	0	19.83	0-1	0	
836.5	20525	5	16-QAM	1	12	19.80	0-1	0	
836.5	20525	5	16-QAM	1	24	19.79	0-1	0	
836.5	20525	5	16-QAM	12	0	19.71	0-2	0	
836.5	20525	5	16-QAM	12	6	19.74	0-2	0	
836.5	20525	5	16-QAM	12	13	19.72	0-2	0	
836.5	20525	5	16-QAM	25	0	19.77	0-2	0	
High	846.5	20625	5	QPSK	1	0	19.91	0	0
	846.5	20625	5	QPSK	1	12	19.95	0	0
	846.5	20625	5	QPSK	1	24	19.98	0	0
	846.5	20625	5	QPSK	12	0	19.76	0-1	0
	846.5	20625	5	QPSK	12	6	19.77	0-1	0
	846.5	20625	5	QPSK	12	13	19.80	0-1	0
	846.5	20625	5	QPSK	25	0	19.74	0-1	0
	846.5	20625	5	16-QAM	1	0	19.85	0-1	0
	846.5	20625	5	16-QAM	1	12	19.78	0-1	0
	846.5	20625	5	16-QAM	1	24	19.86	0-1	0
	846.5	20625	5	16-QAM	12	0	19.72	0-2	0
	846.5	20625	5	16-QAM	12	6	19.71	0-2	0
	846.5	20625	5	16-QAM	12	13	19.80	0-2	0
	846.5	20625	5	16-QAM	25	0	19.79	0-2	0



FCC ID: ZNFV495		SAR EVALUATION REPORT		Reviewed by: Quality Manager
Document S/N: OY1503160550.ZNF	Test Dates: 03/16/15 - 03/25/15	DUT Type: Portable Tablet		Page 24 of 70

Table 8-17
LTE Band 5 (Cell) Conducted Powers – 3 MHz Bandwidth
Reduced Power – Body at 0.0 cm

	Frequency [MHz]	Channel	Bandwidth [MHz]	Modulation	RB Size	RB Offset	Conducted Power [dBm]	MPR Allowed per 3GPP [dB]	MPR [dB]	
Low	825.5	20415	3	QPSK	1	0	19.96	0	0	
	825.5	20415	3	QPSK	1	7	19.94	0	0	
	825.5	20415	3	QPSK	1	14	19.95	0	0	
	825.5	20415	3	QPSK	8	0	19.77	0-1	0	
	825.5	20415	3	QPSK	8	4	19.78	0-1	0	
	825.5	20415	3	QPSK	8	7	19.77	0-1	0	
	825.5	20415	3	QPSK	15	0	19.80	0-1	0	
	825.5	20415	3	16-QAM	1	0	19.85	0-1	0	
	825.5	20415	3	16-QAM	1	7	19.79	0-1	0	
	825.5	20415	3	16-QAM	1	14	19.82	0-1	0	
	825.5	20415	3	16-QAM	8	0	19.73	0-2	0	
	825.5	20415	3	16-QAM	8	4	19.75	0-2	0	
	825.5	20415	3	16-QAM	8	7	19.72	0-2	0	
	825.5	20415	3	16-QAM	15	0	19.76	0-2	0	
	Mid	836.5	20525	3	QPSK	1	0	19.92	0	0
		836.5	20525	3	QPSK	1	7	19.91	0	0
		836.5	20525	3	QPSK	1	14	19.90	0	0
		836.5	20525	3	QPSK	8	0	19.75	0-1	0
836.5		20525	3	QPSK	8	4	19.76	0-1	0	
836.5		20525	3	QPSK	8	7	19.81	0-1	0	
836.5		20525	3	QPSK	15	0	19.78	0-1	0	
836.5		20525	3	16-QAM	1	0	19.87	0-1	0	
836.5		20525	3	16-QAM	1	7	19.79	0-1	0	
836.5		20525	3	16-QAM	1	14	19.84	0-1	0	
836.5		20525	3	16-QAM	8	0	19.71	0-2	0	
836.5		20525	3	16-QAM	8	4	19.70	0-2	0	
836.5		20525	3	16-QAM	8	7	19.69	0-2	0	
836.5		20525	3	16-QAM	15	0	19.79	0-2	0	
High		847.5	20635	3	QPSK	1	0	19.93	0	0
		847.5	20635	3	QPSK	1	7	19.96	0	0
		847.5	20635	3	QPSK	1	14	19.98	0	0
		847.5	20635	3	QPSK	8	0	19.75	0-1	0
	847.5	20635	3	QPSK	8	4	19.82	0-1	0	
	847.5	20635	3	QPSK	8	7	19.86	0-1	0	
	847.5	20635	3	QPSK	15	0	19.76	0-1	0	
	847.5	20635	3	16-QAM	1	0	19.84	0-1	0	
	847.5	20635	3	16-QAM	1	7	19.90	0-1	0	
	847.5	20635	3	16-QAM	1	14	19.88	0-1	0	
	847.5	20635	3	16-QAM	8	0	19.72	0-2	0	
	847.5	20635	3	16-QAM	8	4	19.79	0-2	0	
	847.5	20635	3	16-QAM	8	7	19.77	0-2	0	
	847.5	20635	3	16-QAM	15	0	19.75	0-2	0	

Table 8-18
LTE Band 5 (Cell) Conducted Powers – 1.4 MHz Bandwidth
Reduced Power – Body at 0.0 cm

	Frequency [MHz]	Channel	Bandwidth [MHz]	Modulation	RB Size	RB Offset	Conducted Power [dBm]	MPR Allowed per 3GPP [dB]	MPR [dB]	
Low	824.7	20407	1.4	QPSK	1	0	19.97	0	0	
	824.7	20407	1.4	QPSK	1	2	19.93	0	0	
	824.7	20407	1.4	QPSK	1	5	19.87	0	0	
	824.7	20407	1.4	QPSK	3	0	19.84	0	0	
	824.7	20407	1.4	QPSK	3	2	19.80	0	0	
	824.7	20407	1.4	QPSK	3	3	19.82	0	0	
	824.7	20407	1.4	QPSK	6	0	19.80	0-1	0	
	824.7	20407	1.4	16-QAM	1	0	19.86	0-1	0	
	824.7	20407	1.4	16-QAM	1	2	19.85	0-1	0	
	824.7	20407	1.4	16-QAM	1	5	19.86	0-1	0	
	824.7	20407	1.4	16-QAM	3	0	19.79	0-1	0	
	824.7	20407	1.4	16-QAM	3	2	19.73	0-1	0	
	824.7	20407	1.4	16-QAM	3	3	19.75	0-1	0	
	824.7	20407	1.4	16-QAM	6	0	19.71	0-2	0	
	Mid	836.5	20525	1.4	QPSK	1	0	19.83	0	0
		836.5	20525	1.4	QPSK	1	2	19.80	0	0
		836.5	20525	1.4	QPSK	1	5	19.78	0	0
		836.5	20525	1.4	QPSK	3	0	19.72	0	0
836.5		20525	1.4	QPSK	3	2	19.77	0	0	
836.5		20525	1.4	QPSK	3	3	19.76	0	0	
836.5		20525	1.4	QPSK	6	0	19.71	0-1	0	
836.5		20525	1.4	16-QAM	1	0	19.90	0-1	0	
836.5		20525	1.4	16-QAM	1	2	19.92	0-1	0	
836.5		20525	1.4	16-QAM	1	5	19.85	0-1	0	
836.5		20525	1.4	16-QAM	3	0	19.81	0-1	0	
836.5		20525	1.4	16-QAM	3	2	19.80	0-1	0	
836.5		20525	1.4	16-QAM	3	3	19.74	0-1	0	
836.5		20525	1.4	16-QAM	6	0	19.76	0-2	0	
High		848.3	20643	1.4	QPSK	1	0	19.87	0	0
		848.3	20643	1.4	QPSK	1	2	19.92	0	0
		848.3	20643	1.4	QPSK	1	5	19.98	0	0
		848.3	20643	1.4	QPSK	3	0	19.80	0	0
	848.3	20643	1.4	QPSK	3	2	19.78	0	0	
	848.3	20643	1.4	QPSK	3	3	19.76	0	0	
	848.3	20643	1.4	QPSK	6	0	19.71	0-1	0	
	848.3	20643	1.4	16-QAM	1	0	19.79	0-1	0	
	848.3	20643	1.4	16-QAM	1	2	19.87	0-1	0	
	848.3	20643	1.4	16-QAM	1	5	19.90	0-1	0	
	848.3	20643	1.4	16-QAM	3	0	19.83	0-1	0	
	848.3	20643	1.4	16-QAM	3	2	19.82	0-1	0	
	848.3	20643	1.4	16-QAM	3	3	19.86	0-1	0	
	848.3	20643	1.4	16-QAM	6	0	19.74	0-2	0	

8.2.3 LTE Band 4 (AWS)

Table 8-19
LTE Band 4 (AWS) Conducted Powers - 20 MHz Bandwidth

	Frequency [MHz]	Channel	Bandwidth [MHz]	Modulation	RB Size	RB Offset	Conducted Power [dBm]	MPR Allowed per 3GPP [dB]	MPR [dB]
Mid	1732.5	20175	20	QPSK	1	0	23.85	0	0
	1732.5	20175	20	QPSK	1	50	23.75	0	0
	1732.5	20175	20	QPSK	1	99	23.83	0	0
	1732.5	20175	20	QPSK	50	0	22.81	0-1	1
	1732.5	20175	20	QPSK	50	25	22.86	0-1	1
	1732.5	20175	20	QPSK	50	50	22.82	0-1	1
	1732.5	20175	20	QPSK	100	0	22.70	0-1	1
	1732.5	20175	20	16QAM	1	0	22.82	0-1	1
	1732.5	20175	20	16QAM	1	50	22.93	0-1	1
	1732.5	20175	20	16QAM	1	99	22.90	0-1	1
	1732.5	20175	20	16QAM	50	0	21.73	0-2	2
	1732.5	20175	20	16QAM	50	25	21.71	0-2	2
	1732.5	20175	20	16QAM	50	50	21.80	0-2	2
1732.5	20175	20	16QAM	100	0	21.64	0-2	2	

Note: LTE Band 4 (AWS) at 20 MHz bandwidth does not support three non-overlapping channels. Per KDB Publication 941225 D05v02, when a device supports overlapping channel assignment in a channel bandwidth configuration, the middle channel of the group of overlapping channels should be selected for testing.

Table 8-20
LTE Band 4 (AWS) Conducted Powers - 15 MHz Bandwidth

	Frequency [MHz]	Channel	Bandwidth [MHz]	Modulation	RB Size	RB Offset	Conducted Power [dBm]	MPR Allowed per 3GPP [dB]	MPR [dB]
Low	1717.5	20025	15	QPSK	1	0	23.94	0	0
	1717.5	20025	15	QPSK	1	36	23.91	0	0
	1717.5	20025	15	QPSK	1	74	23.79	0	0
	1717.5	20025	15	QPSK	36	0	22.81	0-1	1
	1717.5	20025	15	QPSK	36	18	22.75	0-1	1
	1717.5	20025	15	QPSK	36	37	22.74	0-1	1
	1717.5	20025	15	QPSK	75	0	22.81	0-1	1
	1717.5	20025	15	16QAM	1	0	22.54	0-1	1
	1717.5	20025	15	16QAM	1	36	22.58	0-1	1
	1717.5	20025	15	16QAM	1	74	22.47	0-1	1
	1717.5	20025	15	16QAM	36	0	21.75	0-2	2
	1717.5	20025	15	16QAM	36	18	21.68	0-2	2
	1717.5	20025	15	16QAM	36	37	21.67	0-2	2
	1717.5	20025	15	16QAM	75	0	21.68	0-2	2
	Mid	1732.5	20175	15	QPSK	1	0	23.70	0
1732.5		20175	15	QPSK	1	36	23.78	0	0
1732.5		20175	15	QPSK	1	74	23.79	0	0
1732.5		20175	15	QPSK	36	0	22.67	0-1	1
1732.5		20175	15	QPSK	36	18	22.70	0-1	1
1732.5		20175	15	QPSK	36	37	22.65	0-1	1
1732.5		20175	15	QPSK	75	0	22.72	0-1	1
1732.5		20175	15	16QAM	1	0	22.46	0-1	1
1732.5		20175	15	16QAM	1	36	22.48	0-1	1
1732.5		20175	15	16QAM	1	74	22.47	0-1	1
1732.5		20175	15	16QAM	36	0	21.61	0-2	2
1732.5		20175	15	16QAM	36	18	21.63	0-2	2
1732.5		20175	15	16QAM	36	37	21.69	0-2	2
1732.5		20175	15	16QAM	75	0	21.65	0-2	2
High		1747.5	20325	15	QPSK	1	0	23.95	0
	1747.5	20325	15	QPSK	1	36	23.84	0	0
	1747.5	20325	15	QPSK	1	74	23.83	0	0
	1747.5	20325	15	QPSK	36	0	22.71	0-1	1
	1747.5	20325	15	QPSK	36	18	22.77	0-1	1
	1747.5	20325	15	QPSK	36	37	22.75	0-1	1
	1747.5	20325	15	QPSK	75	0	22.76	0-1	1
	1747.5	20325	15	16QAM	1	0	22.53	0-1	1
	1747.5	20325	15	16QAM	1	36	22.54	0-1	1
	1747.5	20325	15	16QAM	1	74	22.52	0-1	1
	1747.5	20325	15	16QAM	36	0	21.73	0-2	2
	1747.5	20325	15	16QAM	36	18	21.65	0-2	2
	1747.5	20325	15	16QAM	36	37	21.61	0-2	2
	1747.5	20325	15	16QAM	75	0	21.65	0-2	2



FCC ID: ZNFV495	 PCTEST ENGINEERING LABORATORY, INC.	SAR EVALUATION REPORT		Reviewed by: Quality Manager
Document S/N: OY1503160550.ZNF	Test Dates: 03/16/15 - 03/25/15	DUT Type: Portable Tablet	Page 26 of 70	

Table 8-21
LTE Band 4 (AWS) Conducted Powers - 10 MHz Bandwidth

	Frequency [MHz]	Channel	Bandwidth [MHz]	Modulation	RB Size	RB Offset	Conducted Power [dBm]	MPR Allowed per 3GPP [dB]	MPR [dB]
Low	1715	20000	10	QPSK	1	0	23.77	0	0
	1715	20000	10	QPSK	1	25	23.89	0	0
	1715	20000	10	QPSK	1	49	23.72	0	0
	1715	20000	10	QPSK	25	0	22.74	0-1	1
	1715	20000	10	QPSK	25	12	22.58	0-1	1
	1715	20000	10	QPSK	25	25	22.58	0-1	1
	1715	20000	10	QPSK	50	0	22.64	0-1	1
	1715	20000	10	16QAM	1	0	22.67	0-1	1
	1715	20000	10	16QAM	1	25	22.56	0-1	1
	1715	20000	10	16QAM	1	49	22.58	0-1	1
	1715	20000	10	16QAM	25	0	21.59	0-2	2
	1715	20000	10	16QAM	25	12	21.78	0-2	2
	1715	20000	10	16QAM	25	25	21.63	0-2	2
	1715	20000	10	16QAM	50	0	21.75	0-2	2
	Mid	1732.5	20175	10	QPSK	1	0	23.85	0
1732.5		20175	10	QPSK	1	25	23.97	0	0
1732.5		20175	10	QPSK	1	49	23.79	0	0
1732.5		20175	10	QPSK	25	0	22.53	0-1	1
1732.5		20175	10	QPSK	25	12	22.52	0-1	1
1732.5		20175	10	QPSK	25	25	22.69	0-1	1
1732.5		20175	10	QPSK	50	0	22.74	0-1	1
1732.5		20175	10	16QAM	1	0	22.57	0-1	1
1732.5		20175	10	16QAM	1	25	22.62	0-1	1
1732.5		20175	10	16QAM	1	49	22.52	0-1	1
1732.5		20175	10	16QAM	25	0	21.71	0-2	2
1732.5		20175	10	16QAM	25	12	21.57	0-2	2
1732.5		20175	10	16QAM	25	25	21.68	0-2	2
1732.5		20175	10	16QAM	50	0	21.71	0-2	2
High		1750	20350	10	QPSK	1	0	23.76	0
	1750	20350	10	QPSK	1	25	23.79	0	0
	1750	20350	10	QPSK	1	49	23.91	0	0
	1750	20350	10	QPSK	25	0	22.68	0-1	1
	1750	20350	10	QPSK	25	12	22.66	0-1	1
	1750	20350	10	QPSK	25	25	22.61	0-1	1
	1750	20350	10	QPSK	50	0	22.68	0-1	1
	1750	20350	10	16QAM	1	0	22.64	0-1	1
	1750	20350	10	16QAM	1	25	22.51	0-1	1
	1750	20350	10	16QAM	1	49	22.64	0-1	1
	1750	20350	10	16QAM	25	0	21.75	0-2	2
	1750	20350	10	16QAM	25	12	21.52	0-2	2
	1750	20350	10	16QAM	25	25	21.51	0-2	2
	1750	20350	10	16QAM	50	0	21.74	0-2	2

Table 8-22
LTE Band 4 (AWS) Conducted Powers - 5 MHz Bandwidth

	Frequency [MHz]	Channel	Bandwidth [MHz]	Modulation	RB Size	RB Offset	Conducted Power [dBm]	MPR Allowed per 3GPP [dB]	MPR [dB]
Low	1712.5	19975	5	QPSK	1	0	23.72	0	0
	1712.5	19975	5	QPSK	1	12	23.96	0	0
	1712.5	19975	5	QPSK	1	24	23.64	0	0
	1712.5	19975	5	QPSK	12	0	22.68	0-1	1
	1712.5	19975	5	QPSK	12	6	22.52	0-1	1
	1712.5	19975	5	QPSK	12	13	22.64	0-1	1
	1712.5	19975	5	QPSK	25	0	22.77	0-1	1
	1712.5	19975	5	16-QAM	1	0	22.75	0-1	1
	1712.5	19975	5	16-QAM	1	12	22.60	0-1	1
	1712.5	19975	5	16-QAM	1	24	22.58	0-1	1
	1712.5	19975	5	16-QAM	12	0	21.59	0-2	2
	1712.5	19975	5	16-QAM	12	6	21.71	0-2	2
	1712.5	19975	5	16-QAM	12	13	21.71	0-2	2
	1712.5	19975	5	16-QAM	25	0	21.70	0-2	2
	Mid	1732.5	20175	5	QPSK	1	0	23.96	0
1732.5		20175	5	QPSK	1	12	24.16	0	0
1732.5		20175	5	QPSK	1	24	23.97	0	0
1732.5		20175	5	QPSK	12	0	22.50	0-1	1
1732.5		20175	5	QPSK	12	6	22.61	0-1	1
1732.5		20175	5	QPSK	12	13	22.83	0-1	1
1732.5		20175	5	QPSK	25	0	22.58	0-1	1
1732.5		20175	5	16-QAM	1	0	22.66	0-1	1
1732.5		20175	5	16-QAM	1	12	22.70	0-1	1
1732.5		20175	5	16-QAM	1	24	22.52	0-1	1
1732.5		20175	5	16-QAM	12	0	21.72	0-2	2
1732.5		20175	5	16-QAM	12	6	21.67	0-2	2
1732.5		20175	5	16-QAM	12	13	21.74	0-2	2
1732.5		20175	5	16-QAM	25	0	21.61	0-2	2
High		1752.5	20375	5	QPSK	1	0	23.96	0
	1752.5	20375	5	QPSK	1	12	23.80	0	0
	1752.5	20375	5	QPSK	1	24	24.04	0	0
	1752.5	20375	5	QPSK	12	0	22.54	0-1	1
	1752.5	20375	5	QPSK	12	6	22.59	0-1	1
	1752.5	20375	5	QPSK	12	13	22.52	0-1	1
	1752.5	20375	5	QPSK	25	0	22.66	0-1	1
	1752.5	20375	5	16-QAM	1	0	22.68	0-1	1
	1752.5	20375	5	16-QAM	1	12	22.51	0-1	1
	1752.5	20375	5	16-QAM	1	24	22.81	0-1	1
	1752.5	20375	5	16-QAM	12	0	21.72	0-2	2
	1752.5	20375	5	16-QAM	12	6	21.53	0-2	2
	1752.5	20375	5	16-QAM	12	13	21.59	0-2	2
	1752.5	20375	5	16-QAM	25	0	21.68	0-2	2



FCC ID: ZNFV495	 PCTEST ENGINEERING LABORATORY, INC.	SAR EVALUATION REPORT		Reviewed by: Quality Manager
Document S/N: OY1503160550.ZNF	Test Dates: 03/16/15 - 03/25/15	DUT Type: Portable Tablet		Page 27 of 70

Table 8-23

LTE Band 4 (AWS) Conducted Powers – 3 MHz Bandwidth

	Frequency [MHz]	Channel	Bandwidth [MHz]	Modulation	RB Size	RB Offset	Conducted Power [dBm]	MPR Allowed per 3GPP [dB]	MPR [dB]
Low	1711.5	19965	3	QPSK	1	0	23.75	0	0
	1711.5	19965	3	QPSK	1	7	24.12	0	0
	1711.5	19965	3	QPSK	1	14	23.69	0	0
	1711.5	19965	3	QPSK	8	0	22.59	0-1	1
	1711.5	19965	3	QPSK	8	4	22.76	0-1	1
	1711.5	19965	3	QPSK	8	7	22.56	0-1	1
	1711.5	19965	3	QPSK	15	0	22.88	0-1	1
	1711.5	19965	3	16-QAM	1	0	22.95	0-1	1
	1711.5	19965	3	16-QAM	1	7	22.80	0-1	1
	1711.5	19965	3	16-QAM	1	14	22.59	0-1	1
	1711.5	19965	3	16-QAM	8	0	21.83	0-2	2
	1711.5	19965	3	16-QAM	8	4	21.53	0-2	2
	1711.5	19965	3	16-QAM	8	7	21.52	0-2	2
	1711.5	19965	3	16-QAM	15	0	21.97	0-2	2
	1711.5	19965	3	16-QAM	15	0	21.97	0-2	2
Mid	1732.5	20175	3	QPSK	1	0	24.09	0	0
	1732.5	20175	3	QPSK	1	7	24.13	0	0
	1732.5	20175	3	QPSK	1	14	23.84	0	0
	1732.5	20175	3	QPSK	8	0	22.60	0-1	1
	1732.5	20175	3	QPSK	8	4	22.63	0-1	1
	1732.5	20175	3	QPSK	8	7	22.72	0-1	1
	1732.5	20175	3	QPSK	15	0	22.77	0-1	1
	1732.5	20175	3	16-QAM	1	0	22.63	0-1	1
	1732.5	20175	3	16-QAM	1	7	22.81	0-1	1
	1732.5	20175	3	16-QAM	1	14	22.78	0-1	1
	1732.5	20175	3	16-QAM	8	0	21.83	0-2	2
	1732.5	20175	3	16-QAM	8	4	21.69	0-2	2
	1732.5	20175	3	16-QAM	8	7	21.70	0-2	2
	1732.5	20175	3	16-QAM	15	0	21.57	0-2	2
	1732.5	20175	3	16-QAM	15	0	21.57	0-2	2
High	1753.5	20385	3	QPSK	1	0	23.93	0	0
	1753.5	20385	3	QPSK	1	7	23.67	0	0
	1753.5	20385	3	QPSK	1	14	24.10	0	0
	1753.5	20385	3	QPSK	8	0	22.60	0-1	1
	1753.5	20385	3	QPSK	8	4	22.88	0-1	1
	1753.5	20385	3	QPSK	8	7	22.51	0-1	1
	1753.5	20385	3	QPSK	15	0	22.58	0-1	1
	1753.5	20385	3	16-QAM	1	0	22.75	0-1	1
	1753.5	20385	3	16-QAM	1	7	22.62	0-1	1
	1753.5	20385	3	16-QAM	1	14	23.07	0-1	1
	1753.5	20385	3	16-QAM	8	0	21.87	0-2	2
	1753.5	20385	3	16-QAM	8	4	21.56	0-2	2
	1753.5	20385	3	16-QAM	8	7	21.87	0-2	2
	1753.5	20385	3	16-QAM	15	0	21.87	0-2	2
	1753.5	20385	3	16-QAM	15	0	21.87	0-2	2

Table 8-24

LTE Band 4 (AWS) Conducted Powers – 1.4 MHz Bandwidth

	Frequency [MHz]	Channel	Bandwidth [MHz]	Modulation	RB Size	RB Offset	Conducted Power [dBm]	MPR Allowed per 3GPP [dB]	MPR [dB]
Low	1710.7	19957	1.4	QPSK	1	0	23.86	0	0
	1710.7	19957	1.4	QPSK	1	2	23.90	0	0
	1710.7	19957	1.4	QPSK	1	5	23.80	0	0
	1710.7	19957	1.4	QPSK	3	0	23.64	0	0
	1710.7	19957	1.4	QPSK	3	2	23.65	0	0
	1710.7	19957	1.4	QPSK	3	3	23.50	0	0
	1710.7	19957	1.4	QPSK	6	0	22.72	0-1	1
	1710.7	19957	1.4	16-QAM	1	0	22.97	0-1	1
	1710.7	19957	1.4	16-QAM	1	2	22.56	0-1	1
	1710.7	19957	1.4	16-QAM	1	5	22.59	0-1	1
	1710.7	19957	1.4	16-QAM	3	0	22.91	0-1	1
	1710.7	19957	1.4	16-QAM	3	2	22.96	0-1	1
	1710.7	19957	1.4	16-QAM	3	3	22.85	0-1	1
	1710.7	19957	1.4	16-QAM	6	0	21.98	0-2	2
	1710.7	19957	1.4	16-QAM	6	0	21.98	0-2	2
Mid	1732.5	20175	1.4	QPSK	1	0	23.86	0	0
	1732.5	20175	1.4	QPSK	1	2	24.15	0	0
	1732.5	20175	1.4	QPSK	1	5	23.66	0	0
	1732.5	20175	1.4	QPSK	3	0	23.54	0	0
	1732.5	20175	1.4	QPSK	3	2	23.89	0	0
	1732.5	20175	1.4	QPSK	3	3	23.66	0	0
	1732.5	20175	1.4	QPSK	6	0	22.88	0-1	1
	1732.5	20175	1.4	16-QAM	1	0	22.41	0-1	1
	1732.5	20175	1.4	16-QAM	1	2	23.03	0-1	1
	1732.5	20175	1.4	16-QAM	1	5	22.71	0-1	1
	1732.5	20175	1.4	16-QAM	3	0	22.74	0-1	1
	1732.5	20175	1.4	16-QAM	3	2	22.64	0-1	1
	1732.5	20175	1.4	16-QAM	3	3	22.46	0-1	1
	1732.5	20175	1.4	16-QAM	6	0	21.45	0-2	2
	1732.5	20175	1.4	16-QAM	6	0	21.45	0-2	2
High	1754.3	20393	1.4	QPSK	1	0	23.78	0	0
	1754.3	20393	1.4	QPSK	1	2	23.61	0	0
	1754.3	20393	1.4	QPSK	1	5	23.86	0	0
	1754.3	20393	1.4	QPSK	3	0	23.89	0	0
	1754.3	20393	1.4	QPSK	3	2	23.79	0	0
	1754.3	20393	1.4	QPSK	3	3	23.71	0	0
	1754.3	20393	1.4	QPSK	6	0	22.77	0-1	1
	1754.3	20393	1.4	16-QAM	1	0	23.02	0-1	1
	1754.3	20393	1.4	16-QAM	1	2	22.67	0-1	1
	1754.3	20393	1.4	16-QAM	1	5	22.90	0-1	1
	1754.3	20393	1.4	16-QAM	3	0	22.84	0-1	1
	1754.3	20393	1.4	16-QAM	3	2	22.52	0-1	1
	1754.3	20393	1.4	16-QAM	3	3	22.79	0-1	1
	1754.3	20393	1.4	16-QAM	6	0	22.08	0-2	2
	1754.3	20393	1.4	16-QAM	6	0	22.08	0-2	2



FCC ID: ZNFV495		SAR EVALUATION REPORT		Reviewed by: Quality Manager
Document S/N: OY1503160550.ZNF	Test Dates: 03/16/15 - 03/25/15	DUT Type: Portable Tablet		Page 28 of 70

Table 8-25
LTE Band 4 (AWS) Conducted Powers – 20 MHz Bandwidth
Reduced Power – Body at 0.0 cm

	Frequency [MHz]	Channel	Bandwidth [MHz]	Modulation	RB Size	RB Offset	Conducted Power [dBm]	MPR Allowed per 3GPP [dB]	MPR [dB]
Mid	1732.5	20175	20	QPSK	1	0	12.75	0	0
	1732.5	20175	20	QPSK	1	50	13.18	0	0
	1732.5	20175	20	QPSK	1	99	12.70	0	0
	1732.5	20175	20	QPSK	50	0	12.94	0-1	0
	1732.5	20175	20	QPSK	50	25	13.09	0-1	0
	1732.5	20175	20	QPSK	50	50	12.86	0-1	0
	1732.5	20175	20	QPSK	100	0	12.96	0-1	0
	1732.5	20175	20	16QAM	1	0	12.70	0-1	0
	1732.5	20175	20	16QAM	1	50	13.12	0-1	0
	1732.5	20175	20	16QAM	1	99	12.70	0-1	0
	1732.5	20175	20	16QAM	50	0	12.89	0-2	0
	1732.5	20175	20	16QAM	50	25	13.05	0-2	0
	1732.5	20175	20	16QAM	50	50	12.83	0-2	0
1732.5	20175	20	16QAM	100	0	12.92	0-2	0	

Note: LTE Band 4 (AWS) at 20 MHz bandwidth does not support three non-overlapping channels. Per KDB Publication 941225 D05v02, when a device supports overlapping channel assignment in a channel bandwidth configuration, the middle channel of the group of overlapping channels should be selected for testing.

Table 8-26
LTE Band 4 (AWS) Conducted Powers – 15 MHz Bandwidth
Reduced Power – Body at 0.0 cm

	Frequency [MHz]	Channel	Bandwidth [MHz]	Modulation	RB Size	RB Offset	Conducted Power [dBm]	MPR Allowed per 3GPP [dB]	MPR [dB]	
Low	1717.5	20025	15	QPSK	1	0	12.91	0	0	
	1717.5	20025	15	QPSK	1	36	12.88	0	0	
	1717.5	20025	15	QPSK	1	74	12.98	0	0	
	1717.5	20025	15	QPSK	36	0	12.95	0-1	0	
	1717.5	20025	15	QPSK	36	18	13.04	0-1	0	
	1717.5	20025	15	QPSK	36	37	12.91	0-1	0	
	1717.5	20025	15	QPSK	75	0	12.95	0-1	0	
	1717.5	20025	15	16QAM	1	0	12.71	0-1	0	
	1717.5	20025	15	16QAM	1	36	12.72	0-1	0	
	1717.5	20025	15	16QAM	1	74	12.76	0-1	0	
	1717.5	20025	15	16QAM	36	0	12.85	0-2	0	
	1717.5	20025	15	16QAM	36	18	12.93	0-2	0	
	1717.5	20025	15	16QAM	36	37	12.95	0-2	0	
	1717.5	20025	15	16QAM	75	0	12.86	0-2	0	
	Mid	1732.5	20175	15	QPSK	1	0	13.06	0	0
		1732.5	20175	15	QPSK	1	36	12.99	0	0
		1732.5	20175	15	QPSK	1	74	13.02	0	0
		1732.5	20175	15	QPSK	36	0	12.96	0-1	0
1732.5		20175	15	QPSK	36	18	12.97	0-1	0	
1732.5		20175	15	QPSK	36	37	13.00	0-1	0	
1732.5		20175	15	QPSK	75	0	12.99	0-1	0	
1732.5		20175	15	16QAM	1	0	12.81	0-1	0	
1732.5		20175	15	16QAM	1	36	12.87	0-1	0	
1732.5		20175	15	16QAM	1	74	12.81	0-1	0	
1732.5		20175	15	16QAM	36	0	13.03	0-2	0	
1732.5		20175	15	16QAM	36	18	13.05	0-2	0	
1732.5		20175	15	16QAM	36	37	13.06	0-2	0	
1732.5		20175	15	16QAM	75	0	13.03	0-2	0	
High		1747.5	20325	15	QPSK	1	0	13.01	0	0
		1747.5	20325	15	QPSK	1	36	12.89	0	0
		1747.5	20325	15	QPSK	1	74	12.94	0	0
		1747.5	20325	15	QPSK	36	0	12.89	0-1	0
	1747.5	20325	15	QPSK	36	18	12.87	0-1	0	
	1747.5	20325	15	QPSK	36	37	12.89	0-1	0	
	1747.5	20325	15	QPSK	75	0	12.89	0-1	0	
	1747.5	20325	15	16QAM	1	0	12.78	0-1	0	
	1747.5	20325	15	16QAM	1	36	12.77	0-1	0	
	1747.5	20325	15	16QAM	1	74	12.73	0-1	0	
	1747.5	20325	15	16QAM	36	0	12.95	0-2	0	
	1747.5	20325	15	16QAM	36	18	12.93	0-2	0	
	1747.5	20325	15	16QAM	36	37	12.93	0-2	0	
	1747.5	20325	15	16QAM	75	0	12.92	0-2	0	



FCC ID: ZNFV495	 PCTEST <small>ENGINEERING LABORATORY, INC.</small>	SAR EVALUATION REPORT		Reviewed by: Quality Manager
Document S/N: OY1503160550.ZNF	Test Dates: 03/16/15 - 03/25/15	DUT Type: Portable Tablet		Page 29 of 70

Table 8-27
LTE Band 4 (AWS) Conducted Powers – 10 MHz Bandwidth
Reduced Power – Body at 0.0 cm

	Frequency [MHz]	Channel	Bandwidth [MHz]	Modulation	RB Size	RB Offset	Conducted Power [dBm]	MPR Allowed per 3GPP [dB]	MPR [dB]
Low	1715	20000	10	QPSK	1	0	12.95	0	0
	1715	20000	10	QPSK	1	25	12.87	0	0
	1715	20000	10	QPSK	1	49	13.05	0	0
	1715	20000	10	QPSK	25	0	13.01	0-1	0
	1715	20000	10	QPSK	25	12	12.90	0-1	0
	1715	20000	10	QPSK	25	25	12.97	0-1	0
	1715	20000	10	QPSK	50	0	12.76	0-1	0
	1715	20000	10	16QAM	1	0	12.91	0-1	0
	1715	20000	10	16QAM	1	25	12.91	0-1	0
	1715	20000	10	16QAM	1	49	12.83	0-1	0
	1715	20000	10	16QAM	25	0	13.03	0-2	0
	1715	20000	10	16QAM	25	12	13.08	0-2	0
	1715	20000	10	16QAM	25	25	12.82	0-2	0
	1715	20000	10	16QAM	50	0	13.02	0-2	0
	Mid	1732.5	20175	10	QPSK	1	0	12.92	0
1732.5		20175	10	QPSK	1	25	13.12	0	0
1732.5		20175	10	QPSK	1	49	13.13	0	0
1732.5		20175	10	QPSK	25	0	13.01	0-1	0
1732.5		20175	10	QPSK	25	12	12.96	0-1	0
1732.5		20175	10	QPSK	25	25	12.96	0-1	0
1732.5		20175	10	QPSK	50	0	12.91	0-1	0
1732.5		20175	10	16QAM	1	0	12.92	0-1	0
1732.5		20175	10	16QAM	1	25	12.70	0-1	0
1732.5		20175	10	16QAM	1	49	12.96	0-1	0
1732.5		20175	10	16QAM	25	0	12.88	0-2	0
1732.5		20175	10	16QAM	25	12	13.18	0-2	0
1732.5		20175	10	16QAM	25	25	13.14	0-2	0
1732.5		20175	10	16QAM	50	0	12.87	0-2	0
High		1750	20350	10	QPSK	1	0	13.04	0
	1750	20350	10	QPSK	1	25	12.89	0	0
	1750	20350	10	QPSK	1	49	12.84	0	0
	1750	20350	10	QPSK	25	0	12.90	0-1	0
	1750	20350	10	QPSK	25	12	12.94	0-1	0
	1750	20350	10	QPSK	25	25	12.87	0-1	0
	1750	20350	10	QPSK	50	0	12.72	0-1	0
	1750	20350	10	16QAM	1	0	12.85	0-1	0
	1750	20350	10	16QAM	1	25	12.74	0-1	0
	1750	20350	10	16QAM	1	49	12.71	0-1	0
	1750	20350	10	16QAM	25	0	12.86	0-2	0
	1750	20350	10	16QAM	25	12	13.07	0-2	0
	1750	20350	10	16QAM	25	25	13.00	0-2	0
	1750	20350	10	16QAM	50	0	12.99	0-2	0

Table 8-28
LTE Band 4 (AWS) Conducted Powers – 5 MHz Bandwidth
Reduced Power – Body at 0.0 cm

	Frequency [MHz]	Channel	Bandwidth [MHz]	Modulation	RB Size	RB Offset	Conducted Power [dBm]	MPR Allowed per 3GPP [dB]	MPR [dB]
Low	1712.5	19975	5	QPSK	1	0	12.78	0	0
	1712.5	19975	5	QPSK	1	12	12.92	0	0
	1712.5	19975	5	QPSK	1	24	13.19	0	0
	1712.5	19975	5	QPSK	12	0	13.15	0-1	0
	1712.5	19975	5	QPSK	12	6	12.99	0-1	0
	1712.5	19975	5	QPSK	12	13	12.79	0-1	0
	1712.5	19975	5	QPSK	25	0	12.56	0-1	0
	1712.5	19975	5	16-QAM	1	0	12.83	0-1	0
	1712.5	19975	5	16-QAM	1	12	12.80	0-1	0
	1712.5	19975	5	16-QAM	1	24	12.71	0-1	0
	1712.5	19975	5	16-QAM	12	0	13.18	0-2	0
	1712.5	19975	5	16-QAM	12	6	12.94	0-2	0
	1712.5	19975	5	16-QAM	12	13	12.69	0-2	0
	1712.5	19975	5	16-QAM	25	0	13.13	0-2	0
	Mid	1732.5	20175	5	QPSK	1	0	13.07	0
1732.5		20175	5	QPSK	1	12	13.06	0	0
1732.5		20175	5	QPSK	1	24	13.07	0	0
1732.5		20175	5	QPSK	12	0	13.16	0-1	0
1732.5		20175	5	QPSK	12	6	12.82	0-1	0
1732.5		20175	5	QPSK	12	13	12.91	0-1	0
1732.5		20175	5	QPSK	25	0	12.78	0-1	0
1732.5		20175	5	16-QAM	1	0	12.77	0-1	0
1732.5		20175	5	16-QAM	1	12	12.79	0-1	0
1732.5		20175	5	16-QAM	1	24	13.05	0-1	0
1732.5		20175	5	16-QAM	12	0	13.08	0-2	0
1732.5		20175	5	16-QAM	12	6	13.08	0-2	0
1732.5		20175	5	16-QAM	12	13	13.11	0-2	0
1732.5		20175	5	16-QAM	25	0	12.69	0-2	0
High		1752.5	20375	5	QPSK	1	0	13.01	0
	1752.5	20375	5	QPSK	1	12	12.81	0	0
	1752.5	20375	5	QPSK	1	24	12.66	0	0
	1752.5	20375	5	QPSK	12	0	13.09	0-1	0
	1752.5	20375	5	QPSK	12	6	12.99	0-1	0
	1752.5	20375	5	QPSK	12	13	12.95	0-1	0
	1752.5	20375	5	QPSK	25	0	12.71	0-1	0
	1752.5	20375	5	16-QAM	1	0	13.04	0-1	0
	1752.5	20375	5	16-QAM	1	12	12.57	0-1	0
	1752.5	20375	5	16-QAM	1	24	12.81	0-1	0
	1752.5	20375	5	16-QAM	12	0	12.72	0-2	0
	1752.5	20375	5	16-QAM	12	6	13.01	0-2	0
	1752.5	20375	5	16-QAM	12	13	13.09	0-2	0
	1752.5	20375	5	16-QAM	25	0	12.88	0-2	0





FCC ID: ZNFV495		SAR EVALUATION REPORT		Reviewed by: Quality Manager
Document S/N: OY1503160550.ZNF	Test Dates: 03/16/15 - 03/25/15	DUT Type: Portable Tablet		Page 30 of 70

Table 8-29
LTE Band 4 (AWS) Conducted Powers – 3 MHz Bandwidth
Reduced Power – Body at 0.0 cm

	Frequency [MHz]	Channel	Bandwidth [MHz]	Modulation	RB Size	RB Offset	Conducted Power [dBm]	MPR Allowed per 3GPP [dB]	MPR [dB]
Low	1711.5	19965	3	QPSK	1	0	12.85	0	0
	1711.5	19965	3	QPSK	1	7	13.07	0	0
	1711.5	19965	3	QPSK	1	14	13.18	0	0
	1711.5	19965	3	QPSK	8	0	13.11	0-1	0
	1711.5	19965	3	QPSK	8	4	13.15	0-1	0
	1711.5	19965	3	QPSK	8	7	12.96	0-1	0
	1711.5	19965	3	QPSK	15	0	12.62	0-1	0
	1711.5	19965	3	16-QAM	1	0	12.76	0-1	0
	1711.5	19965	3	16-QAM	1	7	12.68	0-1	0
	1711.5	19965	3	16-QAM	1	14	12.68	0-1	0
	1711.5	19965	3	16-QAM	8	0	13.14	0-2	0
	1711.5	19965	3	16-QAM	8	4	12.89	0-2	0
	1711.5	19965	3	16-QAM	8	7	12.83	0-2	0
	1711.5	19965	3	16-QAM	15	0	12.85	0-2	0
	Mid	1732.5	20175	3	QPSK	1	0	12.97	0
1732.5		20175	3	QPSK	1	7	13.13	0	0
1732.5		20175	3	QPSK	1	14	12.79	0	0
1732.5		20175	3	QPSK	8	0	13.05	0-1	0
1732.5		20175	3	QPSK	8	4	12.77	0-1	0
1732.5		20175	3	QPSK	8	7	12.95	0-1	0
1732.5		20175	3	QPSK	15	0	12.97	0-1	0
1732.5		20175	3	16-QAM	1	0	12.76	0-1	0
1732.5		20175	3	16-QAM	1	7	12.68	0-1	0
1732.5		20175	3	16-QAM	1	14	12.99	0-1	0
1732.5		20175	3	16-QAM	8	0	12.72	0-2	0
1732.5		20175	3	16-QAM	8	4	13.06	0-2	0
1732.5		20175	3	16-QAM	8	7	12.91	0-2	0
1732.5		20175	3	16-QAM	15	0	12.63	0-2	0
High		1753.5	20385	3	QPSK	1	0	12.88	0
	1753.5	20385	3	QPSK	1	7	12.79	0	0
	1753.5	20385	3	QPSK	1	14	12.66	0	0
	1753.5	20385	3	QPSK	8	0	13.04	0-1	0
	1753.5	20385	3	QPSK	8	4	12.94	0-1	0
	1753.5	20385	3	QPSK	8	7	12.96	0-1	0
	1753.5	20385	3	QPSK	15	0	12.83	0-1	0
	1753.5	20385	3	16-QAM	1	0	13.12	0-1	0
	1753.5	20385	3	16-QAM	1	7	12.70	0-1	0
	1753.5	20385	3	16-QAM	1	14	12.96	0-1	0
	1753.5	20385	3	16-QAM	8	0	12.90	0-2	0
	1753.5	20385	3	16-QAM	8	4	12.85	0-2	0
	1753.5	20385	3	16-QAM	8	7	13.08	0-2	0
	1753.5	20385	3	16-QAM	15	0	12.79	0-2	0

Table 8-30
LTE Band 4 (AWS) Conducted Powers – 1.4 MHz Bandwidth
Reduced Power – Body at 0.0 cm

	Frequency [MHz]	Channel	Bandwidth [MHz]	Modulation	RB Size	RB Offset	Conducted Power [dBm]	MPR Allowed per 3GPP [dB]	MPR [dB]
Low	1710.7	19957	1.4	QPSK	1	0	12.66	0	0
	1710.7	19957	1.4	QPSK	1	2	12.90	0	0
	1710.7	19957	1.4	QPSK	1	5	13.05	0	0
	1710.7	19957	1.4	QPSK	3	0	13.07	0	0
	1710.7	19957	1.4	QPSK	3	2	13.00	0	0
	1710.7	19957	1.4	QPSK	3	3	13.04	0	0
	1710.7	19957	1.4	QPSK	6	0	12.54	0-1	0
	1710.7	19957	1.4	16-QAM	1	0	12.67	0-1	0
	1710.7	19957	1.4	16-QAM	1	2	12.63	0-1	0
	1710.7	19957	1.4	16-QAM	1	5	12.75	0-1	0
	1710.7	19957	1.4	16-QAM	3	0	13.17	0-1	0
	1710.7	19957	1.4	16-QAM	3	2	12.97	0-1	0
	1710.7	19957	1.4	16-QAM	3	3	12.72	0-1	0
	1710.7	19957	1.4	16-QAM	6	0	12.80	0-2	0
	Mid	1732.5	20175	1.4	QPSK	1	0	12.90	0
1732.5		20175	1.4	QPSK	1	2	13.13	0	0
1732.5		20175	1.4	QPSK	1	5	12.99	0	0
1732.5		20175	1.4	QPSK	3	0	13.07	0	0
1732.5		20175	1.4	QPSK	3	2	12.89	0	0
1732.5		20175	1.4	QPSK	3	3	12.99	0	0
1732.5		20175	1.4	QPSK	6	0	13.00	0-1	0
1732.5		20175	1.4	16-QAM	1	0	12.75	0-1	0
1732.5		20175	1.4	16-QAM	1	2	12.68	0-1	0
1732.5		20175	1.4	16-QAM	1	5	13.11	0-1	0
1732.5		20175	1.4	16-QAM	3	0	12.65	0-1	0
1732.5		20175	1.4	16-QAM	3	2	13.03	0-1	0
1732.5		20175	1.4	16-QAM	3	3	12.73	0-1	0
1732.5		20175	1.4	16-QAM	6	0	12.54	0-2	0
High		1754.3	20393	1.4	QPSK	1	0	12.76	0
	1754.3	20393	1.4	QPSK	1	2	12.83	0	0
	1754.3	20393	1.4	QPSK	1	5	12.73	0	0
	1754.3	20393	1.4	QPSK	3	0	13.12	0	0
	1754.3	20393	1.4	QPSK	3	2	12.75	0	0
	1754.3	20393	1.4	QPSK	3	3	12.94	0	0
	1754.3	20393	1.4	QPSK	6	0	12.64	0-1	0
	1754.3	20393	1.4	16-QAM	1	0	13.19	0-1	0
	1754.3	20393	1.4	16-QAM	1	2	12.53	0-1	0
	1754.3	20393	1.4	16-QAM	1	5	13.12	0-1	0
	1754.3	20393	1.4	16-QAM	3	0	12.74	0-1	0
	1754.3	20393	1.4	16-QAM	3	2	13.05	0-1	0
	1754.3	20393	1.4	16-QAM	3	3	12.99	0-1	0
	1754.3	20393	1.4	16-QAM	6	0	12.81	0-2	0

FCC ID: ZNFV495	 PCTEST ENGINEERING LABORATORY, INC.	SAR EVALUATION REPORT		Reviewed by: Quality Manager
Document S/N: OY1503160550.ZNF	Test Dates: 03/16/15 - 03/25/15	DUT Type: Portable Tablet	Page 31 of 70	

8.2.4 LTE Band 2 (PCS)

Table 8-31
LTE Band 2 (PCS) Conducted Powers - 20 MHz Bandwidth

	Frequency [MHz]	Channel	Bandwidth [MHz]	Modulation	RB Size	RB Offset	Conducted Power [dBm]	MPR Allowed per 3GPP [dB]	MPR [dB]
Low	1860	18700	20	QPSK	1	0	23.62	0	0
	1860	18700	20	QPSK	1	50	23.65	0	0
	1860	18700	20	QPSK	1	99	23.69	0	0
	1860	18700	20	QPSK	50	0	22.67	0-1	1
	1860	18700	20	QPSK	50	25	22.68	0-1	1
	1860	18700	20	QPSK	50	50	22.67	0-1	1
	1860	18700	20	QPSK	100	0	22.63	0-1	1
	1860	18700	20	16QAM	1	0	22.59	0-1	1
	1860	18700	20	16QAM	1	50	22.63	0-1	1
	1860	18700	20	16QAM	1	99	22.68	0-1	1
	1860	18700	20	16QAM	50	0	21.62	0-2	2
	1860	18700	20	16QAM	50	25	21.60	0-2	2
	1860	18700	20	16QAM	50	50	21.65	0-2	2
	1860	18700	20	16QAM	100	0	21.57	0-2	2
	1880.0	18900	20	QPSK	1	0	23.70	0	0
1880.0	18900	20	QPSK	1	50	23.61	0	0	
1880.0	18900	20	QPSK	1	99	23.55	0	0	
1880.0	18900	20	QPSK	50	0	22.70	0-1	1	
1880.0	18900	20	QPSK	50	25	22.69	0-1	1	
1880.0	18900	20	QPSK	50	50	22.66	0-1	1	
1880.0	18900	20	QPSK	100	0	22.62	0-1	1	
1880.0	18900	20	16QAM	1	0	22.65	0-1	1	
1880.0	18900	20	16QAM	1	50	22.45	0-1	1	
1880.0	18900	20	16QAM	1	99	22.30	0-1	1	
1880.0	18900	20	16QAM	50	0	21.70	0-2	2	
1880.0	18900	20	16QAM	50	25	21.65	0-2	2	
1880.0	18900	20	16QAM	50	50	21.64	0-2	2	
1880.0	18900	20	16QAM	100	0	21.55	0-2	2	
Mid	1900	19100	20	QPSK	1	0	23.50	0	0
	1900	19100	20	QPSK	1	50	23.67	0	0
	1900	19100	20	QPSK	1	99	23.62	0	0
	1900	19100	20	QPSK	50	0	22.69	0-1	1
	1900	19100	20	QPSK	50	25	22.67	0-1	1
	1900	19100	20	QPSK	50	50	22.69	0-1	1
	1900	19100	20	QPSK	100	0	22.67	0-1	1
	1900	19100	20	16QAM	1	0	22.23	0-1	1
	1900	19100	20	16QAM	1	50	22.45	0-1	1
	1900	19100	20	16QAM	1	99	22.28	0-1	1
	1900	19100	20	16QAM	50	0	21.64	0-2	2
	1900	19100	20	16QAM	50	25	21.57	0-2	2
	1900	19100	20	16QAM	50	50	21.61	0-2	2
	1900	19100	20	16QAM	100	0	21.53	0-2	2
	High	1920.5	19125	15	QPSK	1	0	23.32	0
1920.5		19125	15	QPSK	1	36	23.48	0	0
1920.5		19125	15	QPSK	1	74	23.59	0	0
1920.5		19125	15	QPSK	36	0	22.35	0-1	1
1920.5		19125	15	QPSK	36	18	22.28	0-1	1
1920.5		19125	15	QPSK	36	37	22.54	0-1	1
1920.5		19125	15	QPSK	75	0	22.59	0-1	1
1920.5		19125	15	16QAM	1	0	22.17	0-1	1
1920.5		19125	15	16QAM	1	36	22.45	0-1	1
1920.5		19125	15	16QAM	1	74	22.09	0-1	1
1920.5		19125	15	16QAM	36	0	21.66	0-2	2
1920.5		19125	15	16QAM	36	18	21.69	0-2	2
1920.5		19125	15	16QAM	36	37	21.42	0-2	2
1920.5		19125	15	16QAM	75	0	21.53	0-2	2

Table 8-32
LTE Band 2 (PCS) Conducted Powers - 15 MHz Bandwidth

	Frequency [MHz]	Channel	Bandwidth [MHz]	Modulation	RB Size	RB Offset	Conducted Power [dBm]	MPR Allowed per 3GPP [dB]	MPR [dB]
Low	1857.5	18675	15	QPSK	1	0	23.45	0	0
	1857.5	18675	15	QPSK	1	36	23.33	0	0
	1857.5	18675	15	QPSK	1	74	23.29	0	0
	1857.5	18675	15	QPSK	36	0	22.53	0-1	1
	1857.5	18675	15	QPSK	36	18	22.48	0-1	1
	1857.5	18675	15	QPSK	36	37	22.61	0-1	1
	1857.5	18675	15	QPSK	75	0	22.56	0-1	1
	1857.5	18675	15	16QAM	1	0	22.68	0-1	1
	1857.5	18675	15	16QAM	1	36	22.70	0-1	1
	1857.5	18675	15	16QAM	1	74	22.61	0-1	1
	1857.5	18675	15	16QAM	36	0	21.47	0-2	2
	1857.5	18675	15	16QAM	36	18	21.56	0-2	2
	1857.5	18675	15	16QAM	36	37	21.67	0-2	2
	1857.5	18675	15	16QAM	75	0	21.40	0-2	2
	Mid	1880.0	18900	15	QPSK	1	0	23.67	0
1880.0		18900	15	QPSK	1	36	23.50	0	0
1880.0		18900	15	QPSK	1	74	23.55	0	0
1880.0		18900	15	QPSK	36	0	22.38	0-1	1
1880.0		18900	15	QPSK	36	18	22.52	0-1	1
1880.0		18900	15	QPSK	36	37	22.64	0-1	1
1880.0		18900	15	QPSK	75	0	22.46	0-1	1
1880.0		18900	15	16QAM	1	0	22.63	0-1	1
1880.0		18900	15	16QAM	1	36	22.37	0-1	1
1880.0		18900	15	16QAM	1	74	22.18	0-1	1
1880.0		18900	15	16QAM	36	0	21.37	0-2	2
1880.0		18900	15	16QAM	36	18	21.47	0-2	2
1880.0		18900	15	16QAM	36	37	21.57	0-2	2
1880.0		18900	15	16QAM	75	0	21.48	0-2	2
High		1902.5	19125	15	QPSK	1	0	23.32	0
	1902.5	19125	15	QPSK	1	36	23.48	0	0
	1902.5	19125	15	QPSK	1	74	23.59	0	0
	1902.5	19125	15	QPSK	36	0	22.35	0-1	1
	1902.5	19125	15	QPSK	36	18	22.28	0-1	1
	1902.5	19125	15	QPSK	36	37	22.54	0-1	1
	1902.5	19125	15	QPSK	75	0	22.59	0-1	1
	1902.5	19125	15	16QAM	1	0	22.17	0-1	1
	1902.5	19125	15	16QAM	1	36	22.45	0-1	1
	1902.5	19125	15	16QAM	1	74	22.09	0-1	1
	1902.5	19125	15	16QAM	36	0	21.66	0-2	2
	1902.5	19125	15	16QAM	36	18	21.69	0-2	2
	1902.5	19125	15	16QAM	36	37	21.42	0-2	2
	1902.5	19125	15	16QAM	75	0	21.53	0-2	2

Table 8-33

LTE Band 2 (PCS) Conducted Powers - 10 MHz Bandwidth

	Frequency [MHz]	Channel	Bandwidth [MHz]	Modulation	RB Size	RB Offset	Conducted Power [dBm]	MPR Allowed per 3GPP [dB]	MPR [dB]	
Low	1855	18650	10	QPSK	1	0	23.69	0	0	
	1855	18650	10	QPSK	1	25	23.64	0	0	
	1855	18650	10	QPSK	1	49	23.63	0	0	
	1855	18650	10	QPSK	25	0	22.64	0	1	
	1855	18650	10	QPSK	25	12	22.50	0	1	
	1855	18650	10	QPSK	25	25	22.65	0	1	
	1855	18650	10	QPSK	50	0	22.42	0	1	
	1855	18650	10	16QAM	1	0	22.61	0	1	
	1855	18650	10	16QAM	1	25	22.62	0	1	
	1855	18650	10	16QAM	1	49	22.41	0	1	
	1855	18650	10	16QAM	25	0	21.63	0	2	
	1855	18650	10	16QAM	25	12	21.60	0	2	
	1855	18650	10	16QAM	25	25	21.61	0	2	
	1855	18650	10	16QAM	50	0	21.38	0	2	
	Mid	1880.0	18900	10	QPSK	1	0	23.61	0	0
		1880.0	18900	10	QPSK	1	25	23.70	0	0
		1880.0	18900	10	QPSK	1	49	23.42	0	0
		1880.0	18900	10	QPSK	25	0	22.62	0	1
1880.0		18900	10	QPSK	25	12	22.58	0	1	
1880.0		18900	10	QPSK	25	25	22.66	0	1	
1880.0		18900	10	QPSK	50	0	22.66	0	1	
1880.0		18900	10	16QAM	1	0	22.59	0	1	
1880.0		18900	10	16QAM	1	25	22.35	0	1	
1880.0		18900	10	16QAM	1	49	22.28	0	1	
1880.0		18900	10	16QAM	25	0	21.55	0	2	
1880.0		18900	10	16QAM	25	12	21.38	0	2	
1880.0		18900	10	16QAM	25	25	21.49	0	2	
1880.0		18900	10	16QAM	50	0	21.48	0	2	
High		1905	19150	10	QPSK	1	0	23.50	0	0
		1905	19150	10	QPSK	1	25	23.36	0	0
		1905	19150	10	QPSK	1	49	23.50	0	0
		1905	19150	10	QPSK	25	0	22.55	0	1
	1905	19150	10	QPSK	25	12	22.65	0	1	
	1905	19150	10	QPSK	25	25	22.68	0	1	
	1905	19150	10	QPSK	50	0	22.42	0	1	
	1905	19150	10	16QAM	1	0	22.00	0	1	
	1905	19150	10	16QAM	1	25	22.25	0	1	
	1905	19150	10	16QAM	1	49	22.00	0	1	
	1905	19150	10	16QAM	25	0	21.43	0	2	
	1905	19150	10	16QAM	25	12	21.70	0	2	
	1905	19150	10	16QAM	25	25	21.39	0	2	
	1905	19150	10	16QAM	50	0	21.50	0	2	

Table 8-34

LTE Band 2 (PCS) Conducted Powers - 5 MHz Bandwidth

	Frequency [MHz]	Channel	Bandwidth [MHz]	Modulation	RB Size	RB Offset	Conducted Power [dBm]	MPR Allowed per 3GPP [dB]	MPR [dB]	
Low	1852.5	18625	5	QPSK	1	0	23.65	0	0	
	1852.5	18625	5	QPSK	1	12	23.68	0	0	
	1852.5	18625	5	QPSK	1	24	23.55	0	0	
	1852.5	18625	5	QPSK	12	0	22.58	0	1	
	1852.5	18625	5	QPSK	12	6	22.33	0	1	
	1852.5	18625	5	QPSK	12	13	22.70	0	1	
	1852.5	18625	5	QPSK	25	0	22.29	0	1	
	1852.5	18625	5	16-QAM	1	0	22.68	0	1	
	1852.5	18625	5	16-QAM	1	12	22.68	0	1	
	1852.5	18625	5	16-QAM	1	24	22.28	0	1	
	1852.5	18625	5	16-QAM	12	0	21.65	0	2	
	1852.5	18625	5	16-QAM	12	6	21.41	0	2	
	1852.5	18625	5	16-QAM	12	13	21.65	0	2	
	1852.5	18625	5	16-QAM	25	0	21.36	0	2	
	Mid	1880.0	18900	5	QPSK	1	0	23.63	0	0
		1880.0	18900	5	QPSK	1	12	23.57	0	0
		1880.0	18900	5	QPSK	1	24	23.50	0	0
		1880.0	18900	5	QPSK	12	0	22.68	0	1
1880.0		18900	5	QPSK	12	6	22.57	0	1	
1880.0		18900	5	QPSK	12	13	22.70	0	1	
1880.0		18900	5	QPSK	25	0	22.70	0	1	
1880.0		18900	5	16-QAM	1	0	22.55	0	1	
1880.0		18900	5	16-QAM	1	12	22.21	0	1	
1880.0		18900	5	16-QAM	1	24	22.14	0	1	
1880.0		18900	5	16-QAM	12	0	21.40	0	2	
1880.0		18900	5	16-QAM	12	6	21.69	0	2	
1880.0		18900	5	16-QAM	12	13	21.34	0	2	
1880.0		18900	5	16-QAM	25	0	21.59	0	2	
High		1907.5	19175	5	QPSK	1	0	23.61	0	0
		1907.5	19175	5	QPSK	1	12	23.17	0	0
		1907.5	19175	5	QPSK	1	24	23.34	0	0
		1907.5	19175	5	QPSK	12	0	22.67	0	1
	1907.5	19175	5	QPSK	12	6	22.57	0	1	
	1907.5	19175	5	QPSK	12	13	22.54	0	1	
	1907.5	19175	5	QPSK	25	0	22.24	0	1	
	1907.5	19175	5	16-QAM	1	0	22.08	0	1	
	1907.5	19175	5	16-QAM	1	12	22.30	0	1	
	1907.5	19175	5	16-QAM	1	24	22.18	0	1	
	1907.5	19175	5	16-QAM	12	0	21.60	0	2	
	1907.5	19175	5	16-QAM	12	6	21.51	0	2	
	1907.5	19175	5	16-QAM	12	13	21.45	0	2	
	1907.5	19175	5	16-QAM	25	0	21.38	0	2	



FCC ID: ZNFV495	 PCTEST ENGINEERING LABORATORY, INC.	SAR EVALUATION REPORT	 LG	Reviewed by: Quality Manager
Document S/N: OY1503160550.ZNF	Test Dates: 03/16/15 - 03/25/15	DUT Type: Portable Tablet		Page 33 of 70

Table 8-35
LTE Band 2 (PCS) Conducted Powers – 3 MHz Bandwidth

	Frequency [MHz]	Channel	Bandwidth [MHz]	Modulation	RB Size	RB Offset	Conducted Power [dBm]	MPR Allowed per 3GPP [dB]	MPR [dB]
Low	1851.5	18615	3	QPSK	1	0	23.51	0	0
	1851.5	18615	3	QPSK	1	7	23.53	0	0
	1851.5	18615	3	QPSK	1	14	23.56	0	0
	1851.5	18615	3	QPSK	8	0	22.61	0-1	1
	1851.5	18615	3	QPSK	8	4	22.46	0-1	1
	1851.5	18615	3	QPSK	8	7	22.58	0-1	1
	1851.5	18615	3	QPSK	15	0	22.44	0-1	1
	1851.5	18615	3	16-QAM	1	0	22.51	0-1	1
	1851.5	18615	3	16-QAM	1	7	22.61	0-1	1
	1851.5	18615	3	16-QAM	1	14	22.38	0-1	1
	1851.5	18615	3	16-QAM	8	0	21.66	0-2	2
	1851.5	18615	3	16-QAM	8	4	21.34	0-2	2
	1851.5	18615	3	16-QAM	8	7	21.66	0-2	2
	1851.5	18615	3	16-QAM	15	0	21.22	0-2	2
	1851.5	18615	3	16-QAM	15	0	21.22	0-2	2
Mid	1880.0	18900	3	QPSK	1	0	23.57	0	0
	1880.0	18900	3	QPSK	1	7	23.56	0	0
	1880.0	18900	3	QPSK	1	14	23.32	0	0
	1880.0	18900	3	QPSK	8	0	22.64	0-1	1
	1880.0	18900	3	QPSK	8	4	22.55	0-1	1
	1880.0	18900	3	QPSK	8	7	22.65	0-1	1
	1880.0	18900	3	QPSK	15	0	22.52	0-1	1
	1880.0	18900	3	16-QAM	1	0	22.45	0-1	1
	1880.0	18900	3	16-QAM	1	7	22.38	0-1	1
	1880.0	18900	3	16-QAM	1	14	22.09	0-1	1
	1880.0	18900	3	16-QAM	8	0	21.27	0-2	2
	1880.0	18900	3	16-QAM	8	4	21.53	0-2	2
	1880.0	18900	3	16-QAM	8	7	21.29	0-2	2
	1880.0	18900	3	16-QAM	15	0	21.52	0-2	2
	1880.0	18900	3	16-QAM	15	0	21.52	0-2	2
High	1908.5	19185	3	QPSK	1	0	23.67	0	0
	1908.5	19185	3	QPSK	1	7	23.12	0	0
	1908.5	19185	3	QPSK	1	14	23.45	0	0
	1908.5	19185	3	QPSK	8	0	22.63	0-1	1
	1908.5	19185	3	QPSK	8	4	22.38	0-1	1
	1908.5	19185	3	QPSK	8	7	22.52	0-1	1
	1908.5	19185	3	QPSK	15	0	22.11	0-1	1
	1908.5	19185	3	16-QAM	1	0	21.99	0-1	1
	1908.5	19185	3	16-QAM	1	7	22.49	0-1	1
	1908.5	19185	3	16-QAM	1	14	22.00	0-1	1
	1908.5	19185	3	16-QAM	8	0	21.68	0-2	2
	1908.5	19185	3	16-QAM	8	4	21.56	0-2	2
	1908.5	19185	3	16-QAM	8	7	21.56	0-2	2
	1908.5	19185	3	16-QAM	15	0	21.32	0-2	2
	1908.5	19185	3	16-QAM	15	0	21.32	0-2	2

Table 8-36
LTE Band 2 (PCS) Conducted Powers – 1.4 MHz Bandwidth

	Frequency [MHz]	Channel	Bandwidth [MHz]	Modulation	RB Size	RB Offset	Conducted Power [dBm]	MPR Allowed per 3GPP [dB]	MPR [dB]
Low	1850.7	18607	1.4	QPSK	1	0	23.47	0	0
	1850.7	18607	1.4	QPSK	1	2	23.52	0	0
	1850.7	18607	1.4	QPSK	1	5	23.38	0	0
	1850.7	18607	1.4	QPSK	3	0	23.66	0	0
	1850.7	18607	1.4	QPSK	3	2	23.53	0	0
	1850.7	18607	1.4	QPSK	3	3	23.39	0	0
	1850.7	18607	1.4	QPSK	6	0	22.60	0-1	1
	1850.7	18607	1.4	16-QAM	1	0	22.33	0-1	1
	1850.7	18607	1.4	16-QAM	1	2	22.57	0-1	1
	1850.7	18607	1.4	16-QAM	1	5	22.35	0-1	1
	1850.7	18607	1.4	16-QAM	3	0	22.46	0-1	1
	1850.7	18607	1.4	16-QAM	3	2	22.42	0-1	1
	1850.7	18607	1.4	16-QAM	3	3	22.47	0-1	1
	1850.7	18607	1.4	16-QAM	6	0	21.09	0-2	2
	1850.7	18607	1.4	16-QAM	6	0	21.09	0-2	2
Mid	1880.0	18900	1.4	QPSK	1	0	23.39	0	0
	1880.0	18900	1.4	QPSK	1	2	23.57	0	0
	1880.0	18900	1.4	QPSK	1	5	23.13	0	0
	1880.0	18900	1.4	QPSK	3	0	23.69	0	0
	1880.0	18900	1.4	QPSK	3	2	23.60	0	0
	1880.0	18900	1.4	QPSK	3	3	23.46	0	0
	1880.0	18900	1.4	QPSK	6	0	22.43	0-1	1
	1880.0	18900	1.4	16-QAM	1	0	22.26	0-1	1
	1880.0	18900	1.4	16-QAM	1	2	22.55	0-1	1
	1880.0	18900	1.4	16-QAM	1	5	22.03	0-1	1
	1880.0	18900	1.4	16-QAM	3	0	22.33	0-1	1
	1880.0	18900	1.4	16-QAM	3	2	22.38	0-1	1
	1880.0	18900	1.4	16-QAM	3	3	22.31	0-1	1
	1880.0	18900	1.4	16-QAM	6	0	21.35	0-2	2
	1880.0	18900	1.4	16-QAM	6	0	21.35	0-2	2
High	1909.3	19193	1.4	QPSK	1	0	23.61	0	0
	1909.3	19193	1.4	QPSK	1	2	23.14	0	0
	1909.3	19193	1.4	QPSK	1	5	23.59	0	0
	1909.3	19193	1.4	QPSK	3	0	23.46	0	0
	1909.3	19193	1.4	QPSK	3	2	23.28	0	0
	1909.3	19193	1.4	QPSK	3	3	23.44	0	0
	1909.3	19193	1.4	QPSK	6	0	21.96	0-1	1
	1909.3	19193	1.4	16-QAM	1	0	22.05	0-1	1
	1909.3	19193	1.4	16-QAM	1	2	22.55	0-1	1
	1909.3	19193	1.4	16-QAM	1	5	22.08	0-1	1
	1909.3	19193	1.4	16-QAM	3	0	22.39	0-1	1
	1909.3	19193	1.4	16-QAM	3	2	22.65	0-1	1
	1909.3	19193	1.4	16-QAM	3	3	22.47	0-1	1
	1909.3	19193	1.4	16-QAM	6	0	21.42	0-2	2
	1909.3	19193	1.4	16-QAM	6	0	21.42	0-2	2



FCC ID: ZNFV495	 PCTEST ENGINEERING LABORATORY, INC.	SAR EVALUATION REPORT		Reviewed by: Quality Manager
Document S/N: OY1503160550.ZNF	Test Dates: 03/16/15 - 03/25/15	DUT Type: Portable Tablet	Page 34 of 70	

Table 8-37
LTE Band 2 (PCS) Conducted Powers – 20 MHz Bandwidth
Reduced Power – Body at 0.0 cm

	Frequency [MHz]	Channel	Bandwidth [MHz]	Modulation	RB Size	RB Offset	Conducted Power [dBm]	MPR Allowed per 3GPP [dB]	MPR [dB]	
Low	1860	18700	20	QPSK	1	0	12.07	0	0	
	1860	18700	20	QPSK	1	50	12.68	0	0	
	1860	18700	20	QPSK	1	99	11.95	0	0	
	1860	18700	20	QPSK	50	0	12.35	0-1	0	
	1860	18700	20	QPSK	50	25	12.59	0-1	0	
	1860	18700	20	QPSK	50	50	12.33	0-1	0	
	1860	18700	20	QPSK	100	0	12.34	0-1	0	
	1860	18700	20	16QAM	1	0	12.06	0-1	0	
	1860	18700	20	16QAM	1	50	12.59	0-1	0	
	1860	18700	20	16QAM	1	99	12.04	0-1	0	
	1860	18700	20	16QAM	50	0	12.27	0-2	0	
	1860	18700	20	16QAM	50	25	12.36	0-2	0	
	1860	18700	20	16QAM	50	50	12.20	0-2	0	
	1860	18700	20	16QAM	100	0	12.23	0-2	0	
	Mid	1880.0	18900	20	QPSK	1	0	12.00	0	0
		1880.0	18900	20	QPSK	1	50	12.70	0	0
		1880.0	18900	20	QPSK	1	99	12.33	0	0
		1880.0	18900	20	QPSK	50	0	12.38	0-1	0
1880.0		18900	20	QPSK	50	25	12.64	0-1	0	
1880.0		18900	20	QPSK	50	50	12.40	0-1	0	
1880.0		18900	20	QPSK	100	0	12.37	0-1	0	
1880.0		18900	20	16QAM	1	0	12.02	0-1	0	
1880.0		18900	20	16QAM	1	50	12.65	0-1	0	
1880.0		18900	20	16QAM	1	99	12.24	0-1	0	
1880.0		18900	20	16QAM	50	0	12.23	0-2	0	
1880.0		18900	20	16QAM	50	25	12.47	0-2	0	
1880.0		18900	20	16QAM	50	50	12.30	0-2	0	
1880.0		18900	20	16QAM	100	0	12.30	0-2	0	
High		1900	19100	20	QPSK	1	0	12.41	0	0
		1900	19100	20	QPSK	1	50	12.53	0	0
		1900	19100	20	QPSK	1	99	12.14	0	0
		1900	19100	20	QPSK	50	0	12.58	0-1	0
	1900	19100	20	QPSK	50	25	12.63	0-1	0	
	1900	19100	20	QPSK	50	50	12.22	0-1	0	
	1900	19100	20	QPSK	100	0	12.50	0-1	0	
	1900	19100	20	16QAM	1	0	12.32	0-1	0	
	1900	19100	20	16QAM	1	50	12.50	0-1	0	
	1900	19100	20	16QAM	1	99	12.21	0-1	0	
	1900	19100	20	16QAM	50	0	12.37	0-2	0	
	1900	19100	20	16QAM	50	25	12.38	0-2	0	
	1900	19100	20	16QAM	50	50	12.17	0-2	0	
	1900	19100	20	16QAM	100	0	12.25	0-2	0	

Table 8-38
LTE Band 2 (PCS) Conducted Powers – 15 MHz Bandwidth
Reduced Power – Body at 0.0 cm

	Frequency [MHz]	Channel	Bandwidth [MHz]	Modulation	RB Size	RB Offset	Conducted Power [dBm]	MPR Allowed per 3GPP [dB]	MPR [dB]	
Low	1857.5	18675	15	QPSK	1	0	12.32	0	0	
	1857.5	18675	15	QPSK	1	36	12.53	0	0	
	1857.5	18675	15	QPSK	1	74	12.35	0	0	
	1857.5	18675	15	QPSK	36	0	12.35	0-1	0	
	1857.5	18675	15	QPSK	36	18	12.48	0-1	0	
	1857.5	18675	15	QPSK	36	37	12.27	0-1	0	
	1857.5	18675	15	QPSK	75	0	12.36	0-1	0	
	1857.5	18675	15	16QAM	1	0	12.07	0-1	0	
	1857.5	18675	15	16QAM	1	36	12.20	0-1	0	
	1857.5	18675	15	16QAM	1	74	12.13	0-1	0	
	1857.5	18675	15	16QAM	36	0	12.21	0-2	0	
	1857.5	18675	15	16QAM	36	18	12.26	0-2	0	
	1857.5	18675	15	16QAM	36	37	12.17	0-2	0	
	1857.5	18675	15	16QAM	75	0	12.21	0-2	0	
	Mid	1880.0	18900	15	QPSK	1	0	12.35	0	0
		1880.0	18900	15	QPSK	1	36	12.34	0	0
		1880.0	18900	15	QPSK	1	74	12.30	0	0
		1880.0	18900	15	QPSK	36	0	12.41	0-1	0
1880.0		18900	15	QPSK	36	18	12.38	0-1	0	
1880.0		18900	15	QPSK	36	37	12.36	0-1	0	
1880.0		18900	15	QPSK	75	0	12.36	0-1	0	
1880.0		18900	15	16QAM	1	0	12.23	0-1	0	
1880.0		18900	15	16QAM	1	36	12.22	0-1	0	
1880.0		18900	15	16QAM	1	74	12.12	0-1	0	
1880.0		18900	15	16QAM	36	0	12.18	0-2	0	
1880.0		18900	15	16QAM	36	18	12.31	0-2	0	
1880.0		18900	15	16QAM	36	37	12.26	0-2	0	
1880.0		18900	15	16QAM	75	0	12.30	0-2	0	
High		1902.5	19125	15	QPSK	1	0	12.43	0	0
		1902.5	19125	15	QPSK	1	36	12.37	0	0
		1902.5	19125	15	QPSK	1	74	12.41	0	0
		1902.5	19125	15	QPSK	36	0	12.27	0-1	0
	1902.5	19125	15	QPSK	36	18	12.25	0-1	0	
	1902.5	19125	15	QPSK	36	37	12.09	0-1	0	
	1902.5	19125	15	QPSK	75	0	12.16	0-1	0	
	1902.5	19125	15	16QAM	1	0	12.26	0-1	0	
	1902.5	19125	15	16QAM	1	36	12.04	0-1	0	
	1902.5	19125	15	16QAM	1	74	12.21	0-1	0	
	1902.5	19125	15	16QAM	36	0	12.26	0-2	0	
	1902.5	19125	15	16QAM	36	18	12.24	0-2	0	
	1902.5	19125	15	16QAM	36	37	12.07	0-2	0	
	1902.5	19125	15	16QAM	75	0	12.14	0-2	0	

Table 8-39
LTE Band 2 (PCS) Conducted Powers – 10 MHz Bandwidth
Reduced Power – Body at 0.0 cm

	Frequency [MHz]	Channel	Bandwidth [MHz]	Modulation	RB Size	RB Offset	Conducted Power [dBm]	MPR Allowed per 3GPP [dB]	MPR [dB]	
Low	1855	18650	10	QPSK	1	0	12.31	0	0	
	1855	18650	10	QPSK	1	25	12.46	0	0	
	1855	18650	10	QPSK	1	49	12.25	0	0	
	1855	18650	10	QPSK	25	0	12.63	0-1	0	
	1855	18650	10	QPSK	25	12	12.29	0-1	0	
	1855	18650	10	QPSK	25	25	12.50	0-1	0	
	1855	18650	10	QPSK	50	0	12.27	0-1	0	
	1855	18650	10	16QAM	1	0	12.23	0-1	0	
	1855	18650	10	16QAM	1	25	12.18	0-1	0	
	1855	18650	10	16QAM	1	49	12.24	0-1	0	
	1855	18650	10	16QAM	25	0	12.04	0-2	0	
	1855	18650	10	16QAM	25	12	12.29	0-2	0	
	1855	18650	10	16QAM	25	25	12.23	0-2	0	
	1855	18650	10	16QAM	50	0	12.43	0-2	0	
	Mid	1880.0	18900	10	QPSK	1	0	12.47	0	0
		1880.0	18900	10	QPSK	1	25	12.47	0	0
		1880.0	18900	10	QPSK	1	49	12.48	0	0
		1880.0	18900	10	QPSK	25	0	12.61	0-1	0
1880.0		18900	10	QPSK	25	12	12.62	0-1	0	
1880.0		18900	10	QPSK	25	25	12.18	0-1	0	
1880.0		18900	10	QPSK	50	0	12.64	0-1	0	
1880.0		18900	10	16QAM	1	0	12.25	0-1	0	
1880.0		18900	10	16QAM	1	25	12.41	0-1	0	
1880.0		18900	10	16QAM	1	49	12.04	0-1	0	
1880.0		18900	10	16QAM	25	0	12.07	0-2	0	
1880.0		18900	10	16QAM	25	12	12.28	0-2	0	
1880.0		18900	10	16QAM	25	25	12.13	0-2	0	
1880.0		18900	10	16QAM	50	0	12.25	0-2	0	
High		1905	19150	10	QPSK	1	0	12.61	0	0
		1905	19150	10	QPSK	1	25	12.32	0	0
		1905	19150	10	QPSK	1	49	12.42	0	0
		1905	19150	10	QPSK	25	0	12.51	0-1	0
	1905	19150	10	QPSK	25	12	12.29	0-1	0	
	1905	19150	10	QPSK	25	25	12.17	0-1	0	
	1905	19150	10	QPSK	50	0	12.10	0-1	0	
	1905	19150	10	16QAM	1	0	12.41	0-1	0	
	1905	19150	10	16QAM	1	25	12.16	0-1	0	
	1905	19150	10	16QAM	1	49	12.03	0-1	0	
	1905	19150	10	16QAM	25	0	12.06	0-2	0	
	1905	19150	10	16QAM	25	12	12.05	0-2	0	
	1905	19150	10	16QAM	25	25	12.19	0-2	0	
	1905	19150	10	16QAM	50	0	12.44	0-2	0	

Table 8-40
LTE Band 2 (PCS) Conducted Powers – 5 MHz Bandwidth
Reduced Power – Body at 0.0 cm

	Frequency [MHz]	Channel	Bandwidth [MHz]	Modulation	RB Size	RB Offset	Conducted Power [dBm]	MPR Allowed per 3GPP [dB]	MPR [dB]	
Low	1852.5	18625	5	QPSK	1	0	12.60	0	0	
	1852.5	18625	5	QPSK	1	12	12.32	0	0	
	1852.5	18625	5	QPSK	1	24	12.15	0	0	
	1852.5	18625	5	QPSK	12	0	12.44	0-1	0	
	1852.5	18625	5	QPSK	12	6	12.47	0-1	0	
	1852.5	18625	5	QPSK	12	13	12.27	0-1	0	
	1852.5	18625	5	QPSK	25	0	12.41	0-1	0	
	1852.5	18625	5	16-QAM	1	0	12.09	0-1	0	
	1852.5	18625	5	16-QAM	1	12	12.22	0-1	0	
	1852.5	18625	5	16-QAM	1	24	12.07	0-1	0	
	1852.5	18625	5	16-QAM	12	0	12.34	0-2	0	
	1852.5	18625	5	16-QAM	12	6	12.42	0-2	0	
	1852.5	18625	5	16-QAM	12	13	12.23	0-2	0	
	1852.5	18625	5	16-QAM	25	0	12.44	0-2	0	
	Mid	1880.0	18900	5	QPSK	1	0	12.43	0	0
		1880.0	18900	5	QPSK	1	12	12.39	0	0
		1880.0	18900	5	QPSK	1	24	12.57	0	0
		1880.0	18900	5	QPSK	12	0	12.44	0-1	0
1880.0		18900	5	QPSK	12	6	12.40	0-1	0	
1880.0		18900	5	QPSK	12	13	12.05	0-1	0	
1880.0		18900	5	QPSK	25	0	12.41	0-1	0	
1880.0		18900	5	16-QAM	1	0	12.26	0-1	0	
1880.0		18900	5	16-QAM	1	12	12.34	0-1	0	
1880.0		18900	5	16-QAM	1	24	12.32	0-1	0	
1880.0		18900	5	16-QAM	12	0	12.30	0-2	0	
1880.0		18900	5	16-QAM	12	6	12.19	0-2	0	
1880.0		18900	5	16-QAM	12	13	12.28	0-2	0	
1880.0		18900	5	16-QAM	25	0	12.53	0-2	0	
High		1907.5	19175	5	QPSK	1	0	12.34	0	0
		1907.5	19175	5	QPSK	1	12	12.45	0	0
		1907.5	19175	5	QPSK	1	24	12.45	0	0
		1907.5	19175	5	QPSK	12	0	12.26	0-1	0
	1907.5	19175	5	QPSK	12	6	12.36	0-1	0	
	1907.5	19175	5	QPSK	12	13	12.21	0-1	0	
	1907.5	19175	5	QPSK	25	0	12.31	0-1	0	
	1907.5	19175	5	16-QAM	1	0	12.44	0-1	0	
	1907.5	19175	5	16-QAM	1	12	12.35	0-1	0	
	1907.5	19175	5	16-QAM	1	24	12.07	0-1	0	
	1907.5	19175	5	16-QAM	12	0	12.35	0-2	0	
	1907.5	19175	5	16-QAM	12	6	12.12	0-2	0	
	1907.5	19175	5	16-QAM	12	13	12.04	0-2	0	
	1907.5	19175	5	16-QAM	25	0	12.51	0-2	0	

Table 8-41
LTE Band 2 (PCS) Conducted Powers – 3 MHz Bandwidth
Reduced Power – Body at 0.0 cm

	Frequency [MHz]	Channel	Bandwidth [MHz]	Modulation	RB Size	RB Offset	Conducted Power [dBm]	MPR Allowed per 3GPP [dB]	MPR [dB]
Low	1851.5	18615	3	QPSK	1	0	12.49	0	0
	1851.5	18615	3	QPSK	1	7	12.37	0	0
	1851.5	18615	3	QPSK	1	14	12.32	0	0
	1851.5	18615	3	QPSK	8	0	12.30	0-1	0
	1851.5	18615	3	QPSK	8	4	12.65	0-1	0
	1851.5	18615	3	QPSK	8	7	12.18	0-1	0
	1851.5	18615	3	QPSK	15	0	12.38	0-1	0
	1851.5	18615	3	16-QAM	1	0	12.19	0-1	0
	1851.5	18615	3	16-QAM	1	7	12.30	0-1	0
	1851.5	18615	3	16-QAM	1	14	12.22	0-1	0
	1851.5	18615	3	16-QAM	8	0	12.31	0-2	0
	1851.5	18615	3	16-QAM	8	4	12.40	0-2	0
	1851.5	18615	3	16-QAM	8	7	12.23	0-2	0
	1851.5	18615	3	16-QAM	15	0	12.42	0-2	0
	1880.0	18900	3	QPSK	1	0	12.54	0	0
1880.0	18900	3	QPSK	1	7	12.48	0	0	
1880.0	18900	3	QPSK	1	14	12.66	0	0	
1880.0	18900	3	QPSK	8	0	12.28	0-1	0	
1880.0	18900	3	QPSK	8	4	12.55	0-1	0	
1880.0	18900	3	QPSK	8	7	12.15	0-1	0	
1880.0	18900	3	QPSK	15	0	12.25	0-1	0	
1880.0	18900	3	16-QAM	1	0	12.41	0-1	0	
1880.0	18900	3	16-QAM	1	7	12.25	0-1	0	
1880.0	18900	3	16-QAM	1	14	12.19	0-1	0	
1880.0	18900	3	16-QAM	8	0	12.21	0-2	0	
1880.0	18900	3	16-QAM	8	4	12.27	0-2	0	
1880.0	18900	3	16-QAM	8	7	12.37	0-2	0	
1880.0	18900	3	16-QAM	15	0	12.47	0-2	0	
Mid	1908.5	19185	3	QPSK	1	0	12.19	0	0
	1908.5	19185	3	QPSK	1	7	12.65	0	0
	1908.5	19185	3	QPSK	1	14	12.33	0	0
	1908.5	19185	3	QPSK	8	0	12.41	0-1	0
	1908.5	19185	3	QPSK	8	4	12.48	0-1	0
	1908.5	19185	3	QPSK	8	7	12.31	0-1	0
	1908.5	19185	3	QPSK	15	0	12.19	0-1	0
	1908.5	19185	3	16-QAM	1	0	12.25	0-1	0
	1908.5	19185	3	16-QAM	1	7	12.19	0-1	0
	1908.5	19185	3	16-QAM	1	14	12.17	0-1	0
	1908.5	19185	3	16-QAM	8	0	12.42	0-2	0
	1908.5	19185	3	16-QAM	8	4	12.21	0-2	0
	1908.5	19185	3	16-QAM	8	7	12.02	0-2	0
	1908.5	19185	3	16-QAM	15	0	12.64	0-2	0
	High	1850.7	18607	1.4	QPSK	1	0	12.68	0
1850.7		18607	1.4	QPSK	1	2	12.47	0	0
1850.7		18607	1.4	QPSK	1	5	12.38	0	0
1850.7		18607	1.4	QPSK	3	0	12.27	0	0
1850.7		18607	1.4	QPSK	3	2	12.49	0	0
1850.7		18607	1.4	QPSK	3	3	12.11	0	0
1850.7		18607	1.4	QPSK	6	0	12.44	0-1	0
1850.7		18607	1.4	16-QAM	1	0	12.30	0-1	0
1850.7		18607	1.4	16-QAM	1	2	12.38	0-1	0
1850.7		18607	1.4	16-QAM	1	5	12.28	0-1	0
1850.7		18607	1.4	16-QAM	3	0	12.38	0-1	0
1850.7		18607	1.4	16-QAM	3	2	12.31	0-1	0
1850.7		18607	1.4	16-QAM	3	3	12.03	0-1	0
1850.7		18607	1.4	16-QAM	6	0	12.32	0-2	0
1880.0		18900	1.4	QPSK	1	0	12.51	0	0
1880.0	18900	1.4	QPSK	1	2	12.60	0	0	
1880.0	18900	1.4	QPSK	1	5	12.49	0	0	
1880.0	18900	1.4	QPSK	3	0	12.44	0	0	
1880.0	18900	1.4	QPSK	3	2	12.42	0	0	
1880.0	18900	1.4	QPSK	3	3	12.11	0	0	
1880.0	18900	1.4	QPSK	6	0	12.39	0-1	0	
1880.0	18900	1.4	16-QAM	1	0	12.54	0-1	0	
1880.0	18900	1.4	16-QAM	1	2	12.07	0-1	0	
1880.0	18900	1.4	16-QAM	1	5	12.06	0-1	0	
1880.0	18900	1.4	16-QAM	3	0	12.36	0-1	0	
1880.0	18900	1.4	16-QAM	3	2	12.38	0-1	0	
1880.0	18900	1.4	16-QAM	3	3	12.45	0-1	0	
1880.0	18900	1.4	16-QAM	6	0	12.52	0-2	0	
Mid	1909.3	19193	1.4	QPSK	1	0	12.27	0	0
	1909.3	19193	1.4	QPSK	1	2	12.67	0	0
	1909.3	19193	1.4	QPSK	1	5	12.41	0	0
	1909.3	19193	1.4	QPSK	3	0	12.51	0	0
	1909.3	19193	1.4	QPSK	3	2	12.67	0	0
	1909.3	19193	1.4	QPSK	3	3	12.12	0	0
	1909.3	19193	1.4	QPSK	6	0	12.23	0-1	0
	1909.3	19193	1.4	16-QAM	1	0	12.37	0-1	0
	1909.3	19193	1.4	16-QAM	1	2	12.13	0-1	0
	1909.3	19193	1.4	16-QAM	1	5	12.34	0-1	0
	1909.3	19193	1.4	16-QAM	3	0	12.52	0-1	0
	1909.3	19193	1.4	16-QAM	3	2	12.39	0-1	0
	1909.3	19193	1.4	16-QAM	3	3	12.13	0-1	0
	1909.3	19193	1.4	16-QAM	6	0	12.28	0-2	0
	High	1850.7	18607	1.4	QPSK	1	0	12.68	0
1850.7		18607	1.4	QPSK	1	2	12.47	0	0
1850.7		18607	1.4	QPSK	1	5	12.38	0	0
1850.7		18607	1.4	QPSK	3	0	12.27	0	0
1850.7		18607	1.4	QPSK	3	2	12.49	0	0
1850.7		18607	1.4	QPSK	3	3	12.11	0	0
1850.7		18607	1.4	QPSK	6	0	12.44	0-1	0
1850.7		18607	1.4	16-QAM	1	0	12.30	0-1	0
1850.7		18607	1.4	16-QAM	1	2	12.38	0-1	0
1850.7		18607	1.4	16-QAM	1	5	12.28	0-1	0
1850.7		18607	1.4	16-QAM	3	0	12.38	0-1	0
1850.7		18607	1.4	16-QAM	3	2	12.31	0-1	0
1850.7		18607	1.4	16-QAM	3	3	12.03	0-1	0
1850.7		18607	1.4	16-QAM	6	0	12.32	0-2	0
1880.0		18900	1.4	QPSK	1	0	12.51	0	0
1880.0	18900	1.4	QPSK	1	2	12.60	0	0	
1880.0	18900	1.4	QPSK	1	5	12.49	0	0	
1880.0	18900	1.4	QPSK	3	0	12.44	0	0	
1880.0	18900	1.4	QPSK	3	2	12.42	0	0	
1880.0	18900	1.4	QPSK	3	3	12.11	0	0	
1880.0	18900	1.4	QPSK	6	0	12.39	0-1	0	
1880.0	18900	1.4	16-QAM	1	0	12.54	0-1	0	
1880.0	18900	1.4	16-QAM	1	2	12.07	0-1	0	
1880.0	18900	1.4	16-QAM	1	5	12.06	0-1	0	
1880.0	18900	1.4	16-QAM	3	0	12.36	0-1	0	
1880.0	18900	1.4	16-QAM	3	2	12.38	0-1	0	
1880.0	18900	1.4	16-QAM	3	3	12.45	0-1	0	
1880.0	18900	1.4	16-QAM	6	0	12.52	0-2	0	

Table 8-42
LTE Band 2 (PCS) Conducted Powers – 1.4 MHz Bandwidth
Reduced Power – Body at 0.0 cm

	Frequency [MHz]	Channel	Bandwidth [MHz]	Modulation	RB Size	RB Offset	Conducted Power [dBm]	MPR Allowed per 3GPP [dB]	MPR [dB]
Low	1850.7	18607	1.4	QPSK	1	0	12.68	0	0
	1850.7	18607	1.4	QPSK	1	2	12.47	0	0
	1850.7	18607	1.4	QPSK	1	5	12.38	0	0
	1850.7	18607	1.4	QPSK	3	0	12.27	0	0
	1850.7	18607	1.4	QPSK	3	2	12.49	0	0
	1850.7	18607	1.4	QPSK	3	3	12.11	0	0
	1850.7	18607	1.4	QPSK	6	0	12.44	0-1	0
	1850.7	18607	1.4	16-QAM	1	0	12.30	0-1	0
	1850.7	18607	1.4	16-QAM	1	2	12.38	0-1	0
	1850.7	18607	1.4	16-QAM	1	5	12.28	0-1	0
	1850.7	18607	1.4	16-QAM	3	0	12.38	0-1	0
	1850.7	18607	1.4	16-QAM	3	2	12.31	0-1	0
	1850.7	18607	1.4	16-QAM	3	3	12.03	0-1	0
	1850.7	18607	1.4	16-QAM	6	0	12.32	0-2	0
	1880.0	18900	1.4	QPSK	1	0	12.51	0	0
1880.0	18900	1.4	QPSK	1	2	12.60	0	0	
1880.0	18900	1.4	QPSK	1	5	12.49	0	0	
1880.0	18900	1.4	QPSK	3	0	12.44	0	0	
1880.0	18900	1.4	QPSK	3	2	12.42	0	0	
1880.0	18900	1.4	QPSK	3	3	12.11	0	0	
1880.0	18900	1.4	QPSK	6	0	12.39	0-1	0	
1880.0	18900	1.4	16-QAM	1	0	12.54	0-1	0	
1880.0	18900	1.4	16-QAM	1	2	12.07	0-1	0	
1880.0	18900	1.4	16-QAM	1	5	12.06	0-1	0	
1880.0	18900	1.4	16-QAM	3	0	12.36	0-1	0	
1880.0	18900	1.4	16-QAM	3	2	12.38	0-1	0	
1880.0	18900	1.4	16-QAM	3	3	12.45	0-1	0	
1880.0	18900	1.4	16-QAM	6	0	12.52	0-2	0	
Mid	1909.3	19193	1.4	QPSK	1	0	12.27	0	0
	1909.3	19193	1.4	QPSK	1	2	12.67	0	0
	1909.3	19193	1.4	QPSK	1	5	12.41	0	0
	1909.3	19193	1.4	QPSK	3	0	12.51	0	0
	1909.3	19193	1.4	QPSK	3	2	12.67	0	0
	1909.3	19193	1.4	QPSK	3	3	12.12	0	0
	1909.3	19193	1.4	QPSK	6	0	12.23	0-1	0
	1909.3	19193	1.4	16-QAM	1	0	12.37	0-1	0
	1909.3	19193	1.4	16-QAM	1	2	12.13	0-1	0
	1909.3	19193	1.4	16-QAM	1	5	12.34	0-1	0
	1909.3	19193	1.4	16-QAM	3	0	12.52	0-1	0
	1909.3	19193	1.4	16-QAM	3	2	12.39	0-1	0
	1909.3	19193	1.4	16-QAM	3	3	12.13	0-1	0

8.2.5 LTE Band 7

Table 8-43
LTE Band 7 Conducted Powers - 20 MHz Bandwidth

	Frequency [MHz]	Channel	Bandwidth [MHz]	Modulation	RB Size	RB Offset	Conducted Power [dBm]	MPR Allowed per 3GPP [dB]	MPR [dB]
Low	2510	20850	20	QPSK	1	0	24.02	0	0
	2510	20850	20	QPSK	1	50	23.97	0	0
	2510	20850	20	QPSK	1	99	23.86	0	0
	2510	20850	20	QPSK	50	0	22.96	0-1	1
	2510	20850	20	QPSK	50	25	22.98	0-1	1
	2510	20850	20	QPSK	50	50	22.80	0-1	1
	2510	20850	20	QPSK	100	0	22.89	0-1	1
	2510	20850	20	16QAM	1	0	22.87	0-1	1
	2510	20850	20	16QAM	1	50	22.92	0-1	1
	2510	20850	20	16QAM	1	99	22.84	0-1	1
	2510	20850	20	16QAM	50	0	21.70	0-2	2
	2510	20850	20	16QAM	50	25	21.81	0-2	2
	2510	20850	20	16QAM	50	50	21.76	0-2	2
	2510	20850	20	16QAM	100	0	21.73	0-2	2
	Mid	2535.0	21100	20	QPSK	1	0	23.92	0
2535.0		21100	20	QPSK	1	50	23.91	0	0
2535.0		21100	20	QPSK	1	99	23.95	0	0
2535.0		21100	20	QPSK	50	0	22.79	0-1	1
2535.0		21100	20	QPSK	50	25	22.78	0-1	1
2535.0		21100	20	QPSK	50	50	22.82	0-1	1
2535.0		21100	20	QPSK	100	0	22.73	0-1	1
2535.0		21100	20	16QAM	1	0	22.84	0-1	1
2535.0		21100	20	16QAM	1	50	22.72	0-1	1
2535.0		21100	20	16QAM	1	99	22.66	0-1	1
2535.0		21100	20	16QAM	50	0	21.64	0-2	2
2535.0		21100	20	16QAM	50	25	21.62	0-2	2
2535.0		21100	20	16QAM	50	50	21.72	0-2	2
2535.0		21100	20	16QAM	100	0	21.62	0-2	2
High		2560	21350	20	QPSK	1	0	23.83	0
	2560	21350	20	QPSK	1	50	23.75	0	0
	2560	21350	20	QPSK	1	99	23.79	0	0
	2560	21350	20	QPSK	50	0	22.88	0-1	1
	2560	21350	20	QPSK	50	25	22.94	0-1	1
	2560	21350	20	QPSK	50	50	22.94	0-1	1
	2560	21350	20	QPSK	100	0	22.96	0-1	1
	2560	21350	20	16QAM	1	0	22.82	0-1	1
	2560	21350	20	16QAM	1	50	22.73	0-1	1
	2560	21350	20	16QAM	1	99	22.74	0-1	1
	2560	21350	20	16QAM	50	0	21.90	0-2	2
	2560	21350	20	16QAM	50	25	21.87	0-2	2
	2560	21350	20	16QAM	50	50	21.92	0-2	2
	2560	21350	20	16QAM	100	0	21.79	0-2	2

Table 8-44
LTE Band 7 Conducted Powers - 15 MHz Bandwidth

	Frequency [MHz]	Channel	Bandwidth [MHz]	Modulation	RB Size	RB Offset	Conducted Power [dBm]	MPR Allowed per 3GPP [dB]	MPR [dB]
Low	2507.5	20825	15	QPSK	1	0	23.67	0	0
	2507.5	20825	15	QPSK	1	36	23.74	0	0
	2507.5	20825	15	QPSK	1	74	23.79	0	0
	2507.5	20825	15	QPSK	36	0	22.60	0-1	1
	2507.5	20825	15	QPSK	36	18	22.62	0-1	1
	2507.5	20825	15	QPSK	36	37	22.68	0-1	1
	2507.5	20825	15	QPSK	75	0	22.60	0-1	1
	2507.5	20825	15	16QAM	1	0	22.62	0-1	1
	2507.5	20825	15	16QAM	1	36	22.68	0-1	1
	2507.5	20825	15	16QAM	1	74	22.65	0-1	1
	2507.5	20825	15	16QAM	36	0	21.50	0-2	2
	2507.5	20825	15	16QAM	36	18	21.52	0-2	2
	2507.5	20825	15	16QAM	36	37	21.56	0-2	2
	2507.5	20825	15	16QAM	75	0	21.50	0-2	2
	Mid	2535.0	21100	15	QPSK	1	0	23.62	0
2535.0		21100	15	QPSK	1	36	23.74	0	0
2535.0		21100	15	QPSK	1	74	23.71	0	0
2535.0		21100	15	QPSK	36	0	22.53	0-1	1
2535.0		21100	15	QPSK	36	18	22.58	0-1	1
2535.0		21100	15	QPSK	36	37	22.59	0-1	1
2535.0		21100	15	QPSK	75	0	22.52	0-1	1
2535.0		21100	15	16QAM	1	0	22.51	0-1	1
2535.0		21100	15	16QAM	1	36	22.57	0-1	1
2535.0		21100	15	16QAM	1	74	22.60	0-1	1
2535.0		21100	15	16QAM	36	0	21.61	0-2	2
2535.0		21100	15	16QAM	36	18	21.54	0-2	2
2535.0		21100	15	16QAM	36	37	21.52	0-2	2
2535.0		21100	15	16QAM	75	0	21.50	0-2	2
High		2562.5	21375	15	QPSK	1	0	23.78	0
	2562.5	21375	15	QPSK	1	36	23.79	0	0
	2562.5	21375	15	QPSK	1	74	23.87	0	0
	2562.5	21375	15	QPSK	36	0	22.60	0-1	1
	2562.5	21375	15	QPSK	36	18	22.61	0-1	1
	2562.5	21375	15	QPSK	36	37	22.65	0-1	1
	2562.5	21375	15	QPSK	75	0	22.61	0-1	1
	2562.5	21375	15	16QAM	1	0	22.99	0-1	1
	2562.5	21375	15	16QAM	1	36	22.70	0-1	1
	2562.5	21375	15	16QAM	1	74	22.75	0-1	1
	2562.5	21375	15	16QAM	36	0	21.63	0-2	2
	2562.5	21375	15	16QAM	36	18	21.60	0-2	2
	2562.5	21375	15	16QAM	36	37	21.64	0-2	2
	2562.5	21375	15	16QAM	75	0	21.60	0-2	2



FCC ID: ZNFV495	 PCTEST ENGINEERING LABORATORY, INC.	SAR EVALUATION REPORT	 LG	Reviewed by: Quality Manager
Document S/N: OY1503160550.ZNF	Test Dates: 03/16/15 - 03/25/15	DUT Type: Portable Tablet	Page 38 of 70	

Table 8-45
LTE Band 7 Conducted Powers - 10 MHz Bandwidth

	Frequency [MHz]	Channel	Bandwidth [MHz]	Modulation	RB Size	RB Offset	Conducted Power [dBm]	MPR Allowed per 3GPP [dB]	MPR [dB]	
Low	2505	20800	10	QPSK	1	0	23.77	0	0	
	2505	20800	10	QPSK	1	25	23.80	0	0	
	2505	20800	10	QPSK	1	49	23.85	0	0	
	2505	20800	10	QPSK	25	0	22.61	0-1	1	
	2505	20800	10	QPSK	25	12	22.63	0-1	1	
	2505	20800	10	QPSK	25	25	22.65	0-1	1	
	2505	20800	10	QPSK	50	0	22.60	0-1	1	
	2505	20800	10	16QAM	1	0	22.60	0-1	1	
	2505	20800	10	16QAM	1	25	22.64	0-1	1	
	2505	20800	10	16QAM	1	49	22.67	0-1	1	
	2505	20800	10	16QAM	25	0	21.59	0-2	2	
	2505	20800	10	16QAM	25	12	21.56	0-2	2	
	2505	20800	10	16QAM	25	25	21.58	0-2	2	
	2505	20800	10	16QAM	50	0	21.52	0-2	2	
	Mid	2535.0	21100	10	QPSK	1	0	23.71	0	0
		2535.0	21100	10	QPSK	1	25	23.77	0	0
		2535.0	21100	10	QPSK	1	49	23.80	0	0
		2535.0	21100	10	QPSK	25	0	22.65	0-1	1
2535.0		21100	10	QPSK	25	12	22.67	0-1	1	
2535.0		21100	10	QPSK	25	25	22.59	0-1	1	
2535.0		21100	10	QPSK	50	0	22.57	0-1	1	
2535.0		21100	10	16QAM	1	0	22.60	0-1	1	
2535.0		21100	10	16QAM	1	25	22.62	0-1	1	
2535.0		21100	10	16QAM	1	49	22.65	0-1	1	
2535.0		21100	10	16QAM	25	0	21.63	0-2	2	
2535.0		21100	10	16QAM	25	12	21.64	0-2	2	
2535.0		21100	10	16QAM	25	25	21.57	0-2	2	
2535.0		21100	10	16QAM	50	0	21.55	0-2	2	
High		2565	21400	10	QPSK	1	0	23.81	0	0
		2565	21400	10	QPSK	1	25	23.83	0	0
		2565	21400	10	QPSK	1	49	23.92	0	0
		2565	21400	10	QPSK	25	0	22.67	0-1	1
	2565	21400	10	QPSK	25	12	22.71	0-1	1	
	2565	21400	10	QPSK	25	25	22.65	0-1	1	
	2565	21400	10	QPSK	50	0	22.63	0-1	1	
	2565	21400	10	16QAM	1	0	22.66	0-1	1	
	2565	21400	10	16QAM	1	25	22.62	0-1	1	
	2565	21400	10	16QAM	1	49	22.67	0-1	1	
	2565	21400	10	16QAM	25	0	21.64	0-2	2	
	2565	21400	10	16QAM	25	12	21.66	0-2	2	
	2565	21400	10	16QAM	25	25	21.67	0-2	2	
	2565	21400	10	16QAM	50	0	21.63	0-2	2	

Table 8-46
LTE Band 7 Conducted Powers - 5 MHz Bandwidth

	Frequency [MHz]	Channel	Bandwidth [MHz]	Modulation	RB Size	RB Offset	Conducted Power [dBm]	MPR Allowed per 3GPP [dB]	MPR [dB]	
Low	2502.5	20775	5	QPSK	1	0	23.82	0	0	
	2502.5	20775	5	QPSK	1	12	23.75	0	0	
	2502.5	20775	5	QPSK	1	24	23.79	0	0	
	2502.5	20775	5	QPSK	12	0	22.67	0-1	1	
	2502.5	20775	5	QPSK	12	6	22.60	0-1	1	
	2502.5	20775	5	QPSK	12	13	22.61	0-1	1	
	2502.5	20775	5	QPSK	25	0	22.59	0-1	1	
	2502.5	20775	5	16-QAM	1	0	22.67	0-1	1	
	2502.5	20775	5	16-QAM	1	12	22.60	0-1	1	
	2502.5	20775	5	16-QAM	1	24	22.60	0-1	1	
	2502.5	20775	5	16-QAM	12	0	21.58	0-2	2	
	2502.5	20775	5	16-QAM	12	6	21.52	0-2	2	
	2502.5	20775	5	16-QAM	12	13	21.53	0-2	2	
	2502.5	20775	5	16-QAM	25	0	21.51	0-2	2	
	Mid	2535.0	21100	5	QPSK	1	0	23.74	0	0
		2535.0	21100	5	QPSK	1	12	23.79	0	0
		2535.0	21100	5	QPSK	1	24	23.76	0	0
		2535.0	21100	5	QPSK	12	0	22.63	0-1	1
2535.0		21100	5	QPSK	12	6	22.61	0-1	1	
2535.0		21100	5	QPSK	12	13	22.60	0-1	1	
2535.0		21100	5	QPSK	25	0	22.63	0-1	1	
2535.0		21100	5	16-QAM	1	0	22.62	0-1	1	
2535.0		21100	5	16-QAM	1	12	22.60	0-1	1	
2535.0		21100	5	16-QAM	1	24	22.64	0-1	1	
2535.0		21100	5	16-QAM	12	0	21.58	0-2	2	
2535.0		21100	5	16-QAM	12	6	21.60	0-2	2	
2535.0		21100	5	16-QAM	12	13	21.58	0-2	2	
2535.0		21100	5	16-QAM	25	0	21.53	0-2	2	
High		2567.5	21425	5	QPSK	1	0	23.87	0	0
		2567.5	21425	5	QPSK	1	12	23.89	0	0
		2567.5	21425	5	QPSK	1	24	23.90	0	0
		2567.5	21425	5	QPSK	12	0	22.67	0-1	1
	2567.5	21425	5	QPSK	12	6	22.64	0-1	1	
	2567.5	21425	5	QPSK	12	13	22.63	0-1	1	
	2567.5	21425	5	QPSK	25	0	22.64	0-1	1	
	2567.5	21425	5	16-QAM	1	0	22.70	0-1	1	
	2567.5	21425	5	16-QAM	1	12	22.71	0-1	1	
	2567.5	21425	5	16-QAM	1	24	22.72	0-1	1	
	2567.5	21425	5	16-QAM	12	0	21.62	0-2	2	
	2567.5	21425	5	16-QAM	12	6	21.63	0-2	2	
	2567.5	21425	5	16-QAM	12	13	21.60	0-2	2	
	2567.5	21425	5	16-QAM	25	0	21.64	0-2	2	

Table 8-47
LTE Band 7 Conducted Powers – 20 MHz Bandwidth
Reduced Power – Body at 0.0 cm

	Frequency [MHz]	Channel	Bandwidth [MHz]	Modulation	RB Size	RB Offset	Conducted Power [dBm]	MPR Allowed per 3GPP [dB]	MPR [dB]
Low	2510	20850	20	QPSK	1	0	8.37	0	0
	2510	20850	20	QPSK	1	50	9.01	0	0
	2510	20850	20	QPSK	1	99	8.51	0	0
	2510	20850	20	QPSK	50	0	8.72	0.1	0
	2510	20850	20	QPSK	50	25	8.91	0.1	0
	2510	20850	20	QPSK	50	50	8.73	0.1	0
	2510	20850	20	QPSK	100	0	8.78	0.1	0
	2510	20850	20	16QAM	1	0	8.52	0.1	0
	2510	20850	20	16QAM	1	50	9.18	0.1	0
	2510	20850	20	16QAM	1	99	8.65	0.1	0
	2510	20850	20	16QAM	50	0	8.58	0.2	0
	2510	20850	20	16QAM	50	25	8.87	0.2	0
	2510	20850	20	16QAM	50	50	8.98	0.2	0
	2510	20850	20	16QAM	100	0	8.70	0.2	0
	Mid	2535.0	21100	20	QPSK	1	0	8.47	0
2535.0		21100	20	QPSK	1	50	9.09	0	0
2535.0		21100	20	QPSK	1	99	8.55	0	0
2535.0		21100	20	QPSK	50	0	8.73	0.1	0
2535.0		21100	20	QPSK	50	25	9.02	0.1	0
2535.0		21100	20	QPSK	50	50	8.81	0.1	0
2535.0		21100	20	QPSK	100	0	8.78	0.1	0
2535.0		21100	20	16QAM	1	0	8.75	0.1	0
2535.0		21100	20	16QAM	1	50	9.20	0.1	0
2535.0		21100	20	16QAM	1	99	8.77	0.1	0
2535.0		21100	20	16QAM	50	0	8.72	0.2	0
2535.0		21100	20	16QAM	50	25	8.97	0.2	0
2535.0		21100	20	16QAM	50	50	8.77	0.2	0
2535.0		21100	20	16QAM	100	0	8.74	0.2	0
High		2560	21350	20	QPSK	1	0	8.38	0
	2560	21350	20	QPSK	1	50	9.07	0	0
	2560	21350	20	QPSK	1	99	8.60	0	0
	2560	21350	20	QPSK	50	0	8.76	0.1	0
	2560	21350	20	QPSK	50	25	9.00	0.1	0
	2560	21350	20	QPSK	50	50	8.85	0.1	0
	2560	21350	20	QPSK	100	0	8.80	0.1	0
	2560	21350	20	16QAM	1	0	8.63	0.1	0
	2560	21350	20	16QAM	1	50	9.19	0.1	0
	2560	21350	20	16QAM	1	99	8.98	0.1	0
	2560	21350	20	16QAM	50	0	8.66	0.2	0
	2560	21350	20	16QAM	50	25	8.90	0.2	0
	2560	21350	20	16QAM	50	50	8.83	0.2	0
	2560	21350	20	16QAM	100	0	8.79	0.2	0

Table 8-48
LTE Band 7 Conducted Powers – 15 MHz Bandwidth
Reduced Power – Body at 0.0 cm

	Frequency [MHz]	Channel	Bandwidth [MHz]	Modulation	RB Size	RB Offset	Conducted Power [dBm]	MPR Allowed per 3GPP [dB]	MPR [dB]
Low	2507.5	20825	15	QPSK	1	0	8.31	0	0
	2507.5	20825	15	QPSK	1	36	8.51	0	0
	2507.5	20825	15	QPSK	1	74	8.50	0	0
	2507.5	20825	15	QPSK	36	0	8.44	0.1	0
	2507.5	20825	15	QPSK	36	18	8.50	0.1	0
	2507.5	20825	15	QPSK	36	37	8.58	0.1	0
	2507.5	20825	15	QPSK	75	0	8.48	0.1	0
	2507.5	20825	15	16QAM	1	0	8.34	0.1	0
	2507.5	20825	15	16QAM	1	36	8.61	0.1	0
	2507.5	20825	15	16QAM	1	74	8.57	0.1	0
	2507.5	20825	15	16QAM	36	0	8.33	0.2	0
	2507.5	20825	15	16QAM	36	18	8.46	0.2	0
	2507.5	20825	15	16QAM	36	37	8.50	0.2	0
	2507.5	20825	15	16QAM	75	0	8.35	0.2	0
	Mid	2535.0	21100	15	QPSK	1	0	8.43	0
2535.0		21100	15	QPSK	1	36	8.57	0	0
2535.0		21100	15	QPSK	1	74	8.64	0	0
2535.0		21100	15	QPSK	36	0	8.46	0.1	0
2535.0		21100	15	QPSK	36	18	8.57	0.1	0
2535.0		21100	15	QPSK	36	37	8.62	0.1	0
2535.0		21100	15	QPSK	75	0	8.52	0.1	0
2535.0		21100	15	16QAM	1	0	8.52	0.1	0
2535.0		21100	15	16QAM	1	36	8.63	0.1	0
2535.0		21100	15	16QAM	1	74	8.66	0.1	0
2535.0		21100	15	16QAM	36	0	8.41	0.2	0
2535.0		21100	15	16QAM	36	18	8.50	0.2	0
2535.0		21100	15	16QAM	36	37	8.59	0.2	0
2535.0		21100	15	16QAM	75	0	8.49	0.2	0
High		2562.5	21375	15	QPSK	1	0	8.29	0
	2562.5	21375	15	QPSK	1	36	8.48	0	0
	2562.5	21375	15	QPSK	1	74	8.71	0	0
	2562.5	21375	15	QPSK	36	0	8.37	0.1	0
	2562.5	21375	15	QPSK	36	18	8.51	0.1	0
	2562.5	21375	15	QPSK	36	37	8.57	0.1	0
	2562.5	21375	15	QPSK	75	0	8.53	0.1	0
	2562.5	21375	15	16QAM	1	0	8.50	0.1	0
	2562.5	21375	15	16QAM	1	36	8.51	0.1	0
	2562.5	21375	15	16QAM	1	74	8.88	0.1	0
	2562.5	21375	15	16QAM	36	0	8.28	0.2	0
	2562.5	21375	15	16QAM	36	18	8.59	0.2	0
	2562.5	21375	15	16QAM	36	37	8.60	0.2	0
	2562.5	21375	15	16QAM	75	0	8.53	0.2	0





FCC ID: ZNFV495		SAR EVALUATION REPORT		Reviewed by: Quality Manager
Document S/N: OY1503160550.ZNF	Test Dates: 03/16/15 - 03/25/15	DUT Type: Portable Tablet		Page 40 of 70

Table 8-49
LTE Band 7 Conducted Powers – 10 MHz Bandwidth
Reduced Power – Body at 0.0 cm

	Frequency [MHz]	Channel	Bandwidth [MHz]	Modulation	RB Size	RB Offset	Conducted Power [dBm]	MPR Allowed per 3GPP [dB]	MPR [dB]	
Low	2505	20800	10	QPSK	1	0	8.28	0	0	
	2505	20800	10	QPSK	1	25	8.54	0	0	
	2505	20800	10	QPSK	1	49	8.90	0	0	
	2505	20800	10	QPSK	25	0	8.54	0-1	0	
	2505	20800	10	QPSK	25	12	8.62	0-1	0	
	2505	20800	10	QPSK	25	25	8.88	0-1	0	
	2505	20800	10	QPSK	50	0	8.49	0-1	0	
	2505	20800	10	16QAM	1	0	8.40	0-1	0	
	2505	20800	10	16QAM	1	25	8.78	0-1	0	
	2505	20800	10	16QAM	1	49	8.74	0-1	0	
	2505	20800	10	16QAM	25	0	8.42	0-2	0	
	2505	20800	10	16QAM	25	12	8.74	0-2	0	
	2505	20800	10	16QAM	25	25	8.54	0-2	0	
	2505	20800	10	16QAM	50	0	8.53	0-2	0	
	Mid	2535.0	21100	10	QPSK	1	0	8.40	0	0
		2535.0	21100	10	QPSK	1	25	8.51	0	0
2535.0		21100	10	QPSK	1	49	8.89	0	0	
2535.0		21100	10	QPSK	25	0	8.50	0-1	0	
2535.0		21100	10	QPSK	25	12	8.67	0-1	0	
2535.0		21100	10	QPSK	25	25	8.59	0-1	0	
2535.0		21100	10	QPSK	50	0	8.42	0-1	0	
2535.0		21100	10	16QAM	1	0	8.75	0-1	0	
2535.0		21100	10	16QAM	1	25	8.78	0-1	0	
2535.0		21100	10	16QAM	1	49	8.86	0-1	0	
2535.0		21100	10	16QAM	25	0	8.67	0-2	0	
2535.0		21100	10	16QAM	25	12	8.53	0-2	0	
2535.0		21100	10	16QAM	25	25	8.84	0-2	0	
2535.0		21100	10	16QAM	50	0	8.53	0-2	0	
High		2565	21400	10	QPSK	1	0	8.32	0	0
		2565	21400	10	QPSK	1	25	8.67	0	0
	2565	21400	10	QPSK	1	49	8.82	0	0	
	2565	21400	10	QPSK	25	0	8.39	0-1	0	
	2565	21400	10	QPSK	25	12	8.70	0-1	0	
	2565	21400	10	QPSK	25	25	8.78	0-1	0	
	2565	21400	10	QPSK	50	0	8.51	0-1	0	
	2565	21400	10	16QAM	1	0	8.79	0-1	0	
	2565	21400	10	16QAM	1	25	8.48	0-1	0	
	2565	21400	10	16QAM	1	49	8.78	0-1	0	
	2565	21400	10	16QAM	25	0	8.30	0-2	0	
	2565	21400	10	16QAM	25	12	8.54	0-2	0	
	2565	21400	10	16QAM	25	25	8.66	0-2	0	
	2565	21400	10	16QAM	50	0	8.51	0-2	0	

Table 8-50
LTE Band 7 Conducted Powers – 5 MHz Bandwidth
Reduced Power – Body at 0.0 cm

	Frequency [MHz]	Channel	Bandwidth [MHz]	Modulation	RB Size	RB Offset	Conducted Power [dBm]	MPR Allowed per 3GPP [dB]	MPR [dB]	
Low	2502.5	20775	5	QPSK	1	0	8.33	0	0	
	2502.5	20775	5	QPSK	1	12	8.76	0	0	
	2502.5	20775	5	QPSK	1	24	8.78	0	0	
	2502.5	20775	5	QPSK	12	0	8.52	0-1	0	
	2502.5	20775	5	QPSK	12	6	8.74	0-1	0	
	2502.5	20775	5	QPSK	12	13	8.73	0-1	0	
	2502.5	20775	5	QPSK	25	0	8.48	0-1	0	
	2502.5	20775	5	16-QAM	1	0	8.39	0-1	0	
	2502.5	20775	5	16-QAM	1	12	8.65	0-1	0	
	2502.5	20775	5	16-QAM	1	24	8.57	0-1	0	
	2502.5	20775	5	16-QAM	12	0	8.25	0-2	0	
	2502.5	20775	5	16-QAM	12	6	8.67	0-2	0	
	2502.5	20775	5	16-QAM	12	13	8.68	0-2	0	
	2502.5	20775	5	16-QAM	25	0	8.49	0-2	0	
	Mid	2535.0	21100	5	QPSK	1	0	8.29	0	0
		2535.0	21100	5	QPSK	1	12	8.65	0	0
2535.0		21100	5	QPSK	1	24	8.95	0	0	
2535.0		21100	5	QPSK	12	0	8.51	0-1	0	
2535.0		21100	5	QPSK	12	6	8.81	0-1	0	
2535.0		21100	5	QPSK	12	13	8.48	0-1	0	
2535.0		21100	5	QPSK	25	0	8.62	0-1	0	
2535.0		21100	5	16-QAM	1	0	8.81	0-1	0	
2535.0		21100	5	16-QAM	1	12	8.79	0-1	0	
2535.0		21100	5	16-QAM	1	24	8.69	0-1	0	
2535.0		21100	5	16-QAM	12	0	8.85	0-2	0	
2535.0		21100	5	16-QAM	12	6	8.33	0-2	0	
2535.0		21100	5	16-QAM	12	13	8.65	0-2	0	
2535.0		21100	5	16-QAM	25	0	8.49	0-2	0	
High		2567.5	21425	5	QPSK	1	0	8.51	0	0
		2567.5	21425	5	QPSK	1	12	8.56	0	0
	2567.5	21425	5	QPSK	1	24	8.75	0	0	
	2567.5	21425	5	QPSK	12	0	8.22	0-1	0	
	2567.5	21425	5	QPSK	12	6	8.77	0-1	0	
	2567.5	21425	5	QPSK	12	13	8.71	0-1	0	
	2567.5	21425	5	QPSK	25	0	8.48	0-1	0	
	2567.5	21425	5	16-QAM	1	0	8.81	0-1	0	
	2567.5	21425	5	16-QAM	1	12	8.42	0-1	0	
	2567.5	21425	5	16-QAM	1	24	8.70	0-1	0	
	2567.5	21425	5	16-QAM	12	0	8.28	0-2	0	
	2567.5	21425	5	16-QAM	12	6	8.62	0-2	0	
	2567.5	21425	5	16-QAM	12	13	8.74	0-2	0	
	2567.5	21425	5	16-QAM	25	0	8.63	0-2	0	

FCC ID: ZNFV495	 PCTEST ENGINEERING LABORATORY, INC.	SAR EVALUATION REPORT		Reviewed by: Quality Manager
Document S/N: OY1503160550.ZNF	Test Dates: 03/16/15 - 03/25/15	DUT Type: Portable Tablet		Page 41 of 70

8.2.6 LTE Carrier Aggregation Conducted Powers

Table 8-51
Maximum LTE Carrier Aggregation Conducted Powers
Band 4 (PCC) 5 MHz BW + Band 12 (SCC) 10 MHz BW

Band 4 (PCC), 5 MHz + Band 12 (SCC), 10 MHz				
1732.5 MHz / ch.20175 + 737.5 MHz / ch. 5095	PCC UL# RB	PCC UL RB Offset	LTE Rel 10 Tx.Power (dBm)	LTE Rel. 8 Tx.Power (dBm)
	1	12	23.88	24.16

Table 8-52
Reduced- (Body at 0.0 cm) LTE Carrier Aggregation Conducted Powers
Band 4 (PCC) 5 MHz BW + Band 12 (SCC) 10 MHz BW

Band 4 (PCC), 5 MHz + Band 12 (SCC), 10 MHz				
1712.5 MHz / ch.19975 + 737.5 MHz / ch. 5095	PCC UL# RB	PCC UL RB Offset	LTE Rel 10 Tx.Power (dBm)	LTE Rel. 8 Tx.Power (dBm)
	1	24	12.94	13.19

Table 8-53
Maximum LTE Carrier Aggregation Conducted Powers
Band 4 (PCC) 5 MHz BW + Band 17 (SCC) 10 MHz BW

Band 4 (PCC), 5 MHz + Band 17 (SCC), 10 MHz				
1732.5 MHz / ch.20175 + 740 MHz / ch. 5790	PCC UL# RB	PCC UL RB Offset	LTE Rel 10 Tx.Power (dBm)	LTE Rel. 8 Tx.Power (dBm)
	1	12	23.80	24.16

Table 8-54
Reduced- (Body at 0.0 cm) LTE Carrier Aggregation Conducted Powers
Band 4 (PCC) 5 MHz BW + Band 17 (SCC) 10 MHz BW

Band 4 (PCC), 5 MHz + Band 17 (SCC), 10 MHz				
1712.5 MHz / ch.19975 + 740 MHz / ch. 5790	PCC UL# RB	PCC UL RB Offset	LTE Rel 10 Tx.Power (dBm)	LTE Rel. 8 Tx.Power (dBm)
	1	24	13.00	13.19

Table 8-55
Maximum LTE Carrier Aggregation Conducted Powers
Band 4 (PCC) 5 MHz BW + Band 29 (SCC) 10 MHz BW

Band 4 (PCC), 5 MHz + Band 29 (SCC), 10 MHz				
1732.5 MHz / ch.20175 + 722.5 MHz / ch. 9715	PCC UL# RB	PCC UL RB Offset	LTE Rel 10 Tx.Power (dBm)	LTE Rel. 8 Tx.Power (dBm)
	1	12	23.81	24.16

Table 8-56
Reduced- (Body at 0.0 cm) LTE Carrier Aggregation Conducted Powers
Band 4 (PCC) 5 MHz BW+ Band 29 (SCC) 10 MHz BW

Band 4 (PCC), 5 MHz + Band 29 (SCC), 10 MHz				
1712.5 MHz / ch.19975 + 722.5 MHz / ch. 9715	PCC UL# RB	PCC UL RB Offset	LTE Rel 10 Tx.Power (dBm)	LTE Rel. 8 Tx.Power (dBm)
	1	24	13.03	13.19

Table 8-57
Maximum LTE Carrier Aggregation Conducted Powers
Band 2 (PCC) + Band 17 (SCC) 10 MHz BW

Band 2 (PCC) 10 MHz+ Band 17 (SCC), 10 MHz				
1880 MHz / ch.18900 + 740 MHz / ch. 5790	PCC UL# RB	PCC UL RB Offset	LTE Rel 10 Tx.Power (dBm)	LTE Rel. 8 Tx.Power (dBm)
	1	25	23.32	23.70

Table 8-58
Reduced- (Body at 0.0 cm) LTE Carrier Aggregation Conducted Powers
Band 2 (PCC) + Band 17 (SCC) 10 MHz BW

Band 2 (PCC) 10 MHz+ Band 17 (SCC), 10 MHz				
1880 MHz / ch.18900 + 740 MHz / ch. 5790	PCC UL# RB	PCC UL RB Offset	LTE Rel 10 Tx.Power (dBm)	LTE Rel. 8 Tx.Power (dBm)
	50	0	12.53	12.64



FCC ID: ZNFV495		SAR EVALUATION REPORT		Reviewed by: Quality Manager
Document S/N: OY1503160550.ZNF	Test Dates: 03/16/15 - 03/25/15	DUT Type: Portable Tablet		Page 42 of 70

Table 8-59
Maximum LTE Carrier Aggregation Conducted Powers
Band 2 (PCC) + Band 29 (SCC) 10 MHz BW

Band 2 (PCC), 10 MHz + Band 29 (SCC), 10 MHz				
1880 MHz / ch.18900 + 722.5MHz / ch. 9715	PCC UL# RB	PCC UL RB Offset	LTE Rel 10 Tx.Power (dBm)	LTE Rel. 8 Tx.Power (dBm)
	1	25	23.33	23.70

Table 8-60
Reduced- (Body at 0.0 cm) LTE Carrier Aggregation Conducted Powers
Band 2 (PCC) + Band 29 (SCC) 10 MHz BW

Band 2 (PCC), 10 MHz + Band 29 (SCC), 10 MHz				
1880 MHz / ch.18900 + 722.5 MHz / ch. 9715	PCC UL# RB	PCC UL RB Offset	LTE Rel 10 Tx.Power (dBm)	LTE Rel. 8 Tx.Power (dBm)
	50	0	12.56	12.64

Notes:

1. The device does not support all Rel. 10 Carrier Aggregation features due to modem chipset limitation.
2. The device only supports downlink Carrier Aggregation. Uplink Carrier Aggregation is not supported. Power measurements were performed with two DL carriers for the Release 8 configuration that had the highest output power (across all bandwidths, channels and RB Configurations) for each band.
3. This device only supports inter-band CA with 2 carriers (B4+B12, B4+B17, B4+B29, B2+B17, B2+B29)
4. All control and acknowledge data is sent on uplink channels that operate identically to release 8 specifications.

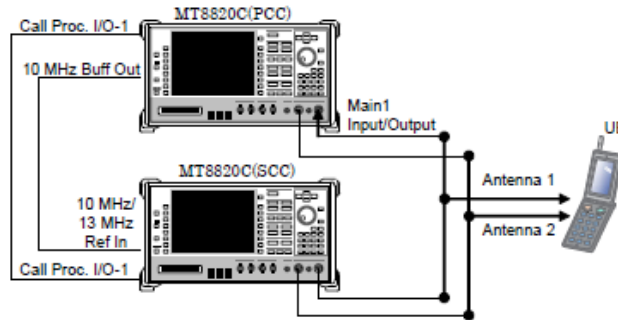



Figure 8-2
Power Measurement Setup

FCC ID: ZNFV495	 PCTEST <small>ENGINEERING LABORATORY, INC.</small>	SAR EVALUATION REPORT		Reviewed by: Quality Manager
Document S/N: OY1503160550.ZNF	Test Dates: 03/16/15 - 03/25/15	DUT Type: Portable Tablet		Page 43 of 70

8.3 WLAN Conducted Powers

Table 8-61
IEEE 802.11b Average RF Power



Mode	Freq [MHz]	Channel	802.11b Conducted Power [dBm]			
			Data Rate [Mbps]			
			1	2	5.5	11
802.11b	2412	1*	12.00	11.97	11.92	11.93
802.11b	2437	6*	12.05	11.91	12.06	12.03
802.11b	2462	11*	11.93	12.13	12.14	12.07

Table 8-62
IEEE 802.11g Average RF Power

Mode	Freq [MHz]	Channel	802.11g Conducted Power [dBm]							
			Data Rate [Mbps]							
			6	9	12	18	24	36	48	54
802.11g	2412	1	9.62	9.70	9.79	9.64	9.62	9.73	9.59	9.74
802.11g	2437	6	9.85	9.91	9.81	9.87	9.76	9.86	9.70	9.85
802.11g	2462	11	9.99	10.01	9.93	9.96	9.93	9.82	9.87	9.85

Table 8-63
IEEE 802.11n Average RF Power

Mode	Freq [MHz]	Channel	802.11n (2.4GHz) Conducted Power [dBm]							
			Data Rate [Mbps]							
			6.5	13	19.5	26	39	52	58.5	65
802.11n	2412	1	8.87	8.90	8.82	8.85	8.84	8.64	8.66	8.84
802.11n	2437	6	9.03	9.06	9.03	8.98	9.01	9.01	8.94	8.95
802.11n	2462	11	9.03	9.11	9.11	9.01	8.90	8.95	8.93	8.97

FCC ID: ZNFV495	 PCTEST ENGINEERING LABORATORY, INC.	SAR EVALUATION REPORT		Reviewed by: Quality Manager
Document S/N: OY1503160550.ZNF	Test Dates: 03/16/15 - 03/25/15	DUT Type: Portable Tablet		Page 44 of 70

**Table 8-64
IEEE 802.11a Average RF Power**

Mode	Freq [MHz]	Channel	802.11a Conducted Power [dBm]							
			Data Rate [Mbps]							
			6	9	12	18	24	36	48	54
802.11a	5180	36*	9.26	9.27	9.22	9.30	9.31	9.25	9.17	9.24
802.11a	5200	40	9.24	9.16	9.16	9.21	9.14	9.12	9.05	8.96
802.11a	5220	44	9.21	9.20	9.14	9.14	9.12	9.25	9.07	9.10
802.11a	5240	48*	9.11	9.01	9.10	9.11	9.01	9.00	8.99	8.97
802.11a	5260	52*	9.16	9.33	9.21	9.31	9.30	9.27	9.20	9.19
802.11a	5280	56	9.22	9.20	9.23	9.21	9.26	9.13	9.18	9.17
802.11a	5300	60	9.17	9.18	9.24	9.24	9.26	9.26	9.22	9.33
802.11a	5320	64*	9.11	9.07	9.10	9.06	9.05	9.13	9.05	9.18
802.11a	5500	100	9.11	9.00	9.09	9.17	9.03	9.06	8.99	9.07
802.11a	5520	104*	8.87	8.87	8.91	8.86	8.87	8.92	8.89	9.04
802.11a	5540	108	8.82	8.71	8.77	8.75	8.83	8.90	8.83	8.69
802.11a	5560	112	8.96	9.00	9.02	8.96	9.05	9.00	9.00	8.80
802.11a	5580	116*	9.13	9.27	9.33	9.20	9.14	9.13	9.14	9.20
802.11a	5600	120	N/A	N/A	N/A	N/A	N/A	N/A	N/A	N/A
802.11a	5620	124	N/A	N/A	N/A	N/A	N/A	N/A	N/A	N/A
802.11a	5640	128	N/A	N/A	N/A	N/A	N/A	N/A	N/A	N/A
802.11a	5660	132	8.80	8.76	8.81	8.87	8.85	8.72	8.87	8.83
802.11a	5680	136*	8.83	8.81	8.78	8.77	8.72	8.91	8.79	8.76
802.11a	5700	140	8.87	8.87	8.87	8.91	8.84	8.70	8.84	8.78
802.11a	5745	149*	9.20	9.09	9.17	9.13	9.10	9.20	9.04	9.09
802.11a	5765	153	9.00	8.92	9.05	8.90	8.99	8.91	8.94	8.99
802.11a	5785	157*	9.24	9.14	9.14	9.19	9.06	9.11	9.16	9.12
802.11a	5805	161	9.08	9.09	9.06	9.17	9.12	9.05	9.18	9.05
802.11a	5825	165*	9.03	9.00	9.12	9.13	9.07	8.94	9.07	9.01

(*) – indicates default channels per KDB Publication 248227 D01v01r02. When the adjacent channels are higher in power than the default channels, these “required channels” are considered for SAR testing instead of the default channels.



FCC ID: ZNFV495		SAR EVALUATION REPORT		Reviewed by: Quality Manager
Document S/N: OY1503160550.ZNF	Test Dates: 03/16/15 - 03/25/15	DUT Type: Portable Tablet	Page 45 of 70	

Table 8-65
IEEE 802.11n Average RF Power – 20 MHz Bandwidth



Mode	Freq [MHz]	Channel	20MHz BW 802.11n (5GHz) Conducted Power [dBm]							
			Data Rate [Mbps]							
			6.5	13	19.5	26	39	52	58.5	65
802.11n	5180	36	8.38	8.46	8.42	8.37	8.39	8.40	8.45	8.53
802.11n	5200	40	8.34	8.38	8.28	8.23	8.22	8.22	8.36	8.21
802.11n	5220	44	8.26	8.26	8.15	8.20	8.31	8.22	8.17	8.17
802.11n	5240	48	8.18	8.28	8.17	8.02	8.16	8.04	8.17	8.18
802.11n	5260	52	8.38	8.35	8.39	8.33	8.29	8.24	8.33	8.30
802.11n	5280	56	8.40	8.41	8.40	8.37	8.29	8.45	8.34	8.21
802.11n	5300	60	8.36	8.43	8.40	8.33	8.40	8.35	8.33	8.25
802.11n	5320	64	8.27	8.28	8.34	8.39	8.16	8.11	8.06	8.26
802.11n	5500	100	8.24	8.29	8.20	8.25	8.29	8.20	8.19	8.23
802.11n	5520	104	8.11	8.19	8.15	8.09	8.07	8.15	8.16	8.01
802.11n	5540	108	8.08	8.08	8.00	7.95	8.02	8.01	7.98	7.89
802.11n	5560	112	8.18	8.19	8.16	8.14	8.20	8.17	8.17	8.16
802.11n	5580	116	8.10	8.09	7.97	7.99	8.11	7.99	8.00	7.99
802.11n	5600	120	N/A	N/A	N/A	N/A	N/A	N/A	N/A	N/A
802.11n	5620	124	N/A	N/A	N/A	N/A	N/A	N/A	N/A	N/A
802.11n	5640	128	N/A	N/A	N/A	N/A	N/A	N/A	N/A	N/A
802.11n	5660	132	7.74	7.74	7.73	7.73	7.71	7.68	7.69	7.73
802.11n	5680	136	7.71	7.81	7.69	7.78	7.73	7.69	7.64	7.74
802.11n	5700	140	7.78	7.80	7.60	7.63	7.79	7.78	7.57	7.69
802.11n	5745	149	7.68	7.73	7.79	7.79	7.66	7.77	7.75	7.80
802.11n	5765	153	7.66	7.71	7.66	7.75	7.68	7.54	7.82	7.68
802.11n	5785	157	7.70	7.71	7.80	7.77	7.78	7.75	7.74	7.74
802.11n	5805	161	7.85	7.84	7.84	7.65	7.67	7.73	7.65	7.76
802.11n	5825	165	7.71	7.83	7.85	7.60	7.58	7.69	7.61	7.68

Table 8-66
IEEE 802.11n Average RF Power – 40 MHz Bandwidth

Mode	Freq [MHz]	Channel	40MHz BW 802.11n (5GHz) Conducted Power [dBm]							
			Data Rate [Mbps]							
			13.5	27	40.5	54	81	108	121.5	135
802.11n	5190	38	6.88	6.93	6.87	6.84	6.76	6.79	6.70	6.87
802.11n	5230	46	6.64	6.61	6.64	6.69	6.63	6.71	6.64	6.70
802.11n	5270	54	6.87	6.80	6.82	6.87	6.71	6.72	6.78	6.63
802.11n	5310	62	6.71	6.84	6.74	6.81	6.81	6.69	6.70	6.71
802.11n	5510	102	6.54	6.63	6.49	6.49	6.55	6.48	6.64	6.55
802.11n	5550	110	6.54	6.52	6.36	6.54	6.26	6.56	6.47	6.48
802.11n	5590	118	N/A	N/A	N/A	N/A	N/A	N/A	N/A	N/A
802.11n	5630	126	N/A	N/A	N/A	N/A	N/A	N/A	N/A	N/A
802.11n	5670	134	6.22	6.35	6.42	6.39	6.19	6.33	6.27	6.40
802.11n	5755	151	6.60	6.35	6.43	6.39	6.39	6.33	6.39	6.43
802.11n	5795	159	6.60	6.47	6.47	6.51	6.18	6.33	6.26	6.31

Justification for reduced test configurations for WIFI channels per KDB Publication 248227 D01v01r02 and October 2012/April 2013 FCC/TCB Meeting Notes:

- For 2.4 GHz operations, highest average RF output power channel for the lowest data rate for IEEE 802.11b were selected for SAR evaluation. Some additional 802.11n tests were also evaluated and included in this report per manufacturer request.

FCC ID: ZNFV495	 PCTEST <small>ENGINEERING LABORATORY, INC.</small>	SAR EVALUATION REPORT		Reviewed by: Quality Manager
Document S/N: OY1503160550.ZNF	Test Dates: 03/16/15 - 03/25/15	DUT Type: Portable Tablet	Page 46 of 70	

- For 5 GHz operations, highest average RF output power channel for the lowest data rate for IEEE 802.11a were selected for SAR evaluation. Some additional 802.11n tests were also evaluated and included in this report per manufacturer request.
- When the maximum extrapolated peak SAR of the zoom scan for the maximum output channel is <1.6 W/kg and the reported 1g averaged SAR is <0.8 W/kg, SAR testing on other channels is not required. Otherwise, the other default (or corresponding required) test channels were additionally tested using the lowest data rate.
- The bolded data rate and channel above were tested for SAR.

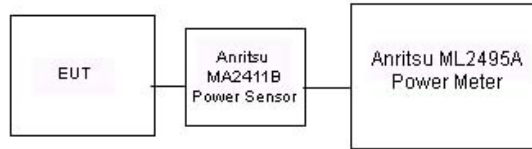

Figure 8-3
Power Measurement Setup

8.1 Bluetooth Conducted Powers

Table 8-67
Bluetooth RF Conducted Powers

Frequency [MHz]	Data Rate [Mbps]	Channel No.	Avg Conducted Power	
			[dBm]	[mW]
2402	1.0	0	6.61	4.586
2441	1.0	39	8.31	6.775
2480	1.0	78	6.15	4.123
2402	2.0	0	4.05	2.541
2441	2.0	39	5.71	3.721
2480	2.0	78	3.55	2.264
2402	3.0	0	4.06	2.548
2441	3.0	39	5.77	3.777
2480	3.0	78	3.59	2.285

Note: The bolded data rate and channel above was tested for SAR.

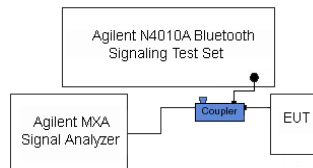



Figure 8-4
Power Measurement Setup



FCC ID: ZNFV495	 PCTEST ENGINEERING LABORATORY, INC.	SAR EVALUATION REPORT		Reviewed by: Quality Manager
Document S/N: OY1503160550.ZNF	Test Dates: 03/16/15 - 03/25/15	DUT Type: Portable Tablet	Page 47 of 70	

9.1 Tissue Verification

Table 9-1
Measured Tissue Properties

Tissue Type	Calibrated Date:	Tissue Temp During Calibration (C°)	Measured Frequency (MHz)	Measured Conductivity, σ (S/m)	Measured Dielectric Constant, ϵ	TARGET Conductivity, σ (S/m)	TARGET Dielectric Constant, ϵ	% dev σ	% dev ϵ
03/24/2015	750B	22.1	695	0.924	55.511	0.959	55.745	-3.65%	-0.42%
			710	0.936	55.316	0.960	55.687	-2.50%	-0.67%
			725	0.950	55.208	0.961	55.629	-1.14%	-0.76%
			740	0.965	55.021	0.963	55.570	0.21%	-0.99%
			755	0.977	54.880	0.964	55.512	1.35%	-1.14%
03/16/2015	835B	22.6	820	1.003	54.206	0.969	55.258	3.51%	-1.90%
			835	1.018	54.016	0.970	55.200	4.95%	-2.14%
			850	1.028	53.872	0.988	55.154	4.05%	-2.32%
03/18/2015	835B	22.5	820	0.996	54.682	0.969	55.258	2.79%	-1.04%
			835	1.010	54.531	0.970	55.200	4.12%	-1.21%
			850	1.023	54.403	0.988	55.154	3.54%	-1.36%
03/23/2015	1750B	21.8	1710	1.432	52.326	1.463	53.537	-2.12%	-2.26%
			1750	1.477	52.150	1.488	53.432	-0.74%	-2.40%
			1790	1.524	52.001	1.514	53.326	0.66%	-2.48%
03/17/2015	1900B	23.0	1850	1.514	51.641	1.520	53.300	-0.39%	-3.11%
			1880	1.548	51.527	1.520	53.300	1.84%	-3.33%
			1910	1.582	51.409	1.520	53.300	4.08%	-3.55%
03/17/2015	2450B	22.4	2401	1.958	50.991	1.903	52.765	2.89%	-3.36%
			2450	2.028	50.797	1.950	52.700	4.00%	-3.61%
			2499	2.089	50.607	2.019	52.638	3.47%	-3.86%
03/25/2015	2450- 2600B	21.2	2401	1.973	51.277	1.903	52.765	3.68%	-2.82%
			2450	2.041	51.077	1.950	52.700	4.67%	-3.08%
			2499	2.104	50.901	2.019	52.638	4.21%	-3.30%
			2500	2.104	50.891	2.021	52.636	4.11%	-3.32%
			2550	2.176	50.719	2.092	52.573	4.02%	-3.53%
03/17/2015	5200B-5800B	23.0	2600	2.247	50.520	2.163	52.509	3.88%	-3.79%
			5180	5.129	47.585	5.276	49.041	-2.79%	-2.97%
			5200	5.152	47.539	5.299	49.014	-2.77%	-3.01%
			5260	5.222	47.475	5.369	48.933	-2.74%	-2.98%
			5280	5.253	47.450	5.393	48.906	-2.60%	-2.98%
			5300	5.286	47.366	5.416	48.879	-2.40%	-3.10%
			5500	5.558	47.192	5.650	48.607	-1.63%	-2.91%
			5520	5.586	47.159	5.673	48.580	-1.53%	-2.93%
			5580	5.664	47.062	5.743	48.499	-1.38%	-2.96%
			5600	5.692	47.066	5.766	48.471	-1.28%	-2.90%
			5700	5.816	46.935	5.883	48.336	-1.14%	-2.90%
			5745	5.855	46.836	5.936	48.275	-1.36%	-2.98%
			5765	5.877	46.800	5.959	48.248	-1.38%	-3.00%
			5785	5.916	46.786	5.982	48.220	-1.10%	-2.97%
			5800	5.941	46.766	6.000	48.200	-0.98%	-2.98%
5805	5.945	46.748	6.006	48.193	-1.02%	-3.00%			

The above measured tissue parameters were used in the DASY software. The DASY software was used to perform interpolation to determine the dielectric parameters at the SAR test device frequencies (per KDB Publication 865664 and IEEE 1528-2013 6.6.1.2). The tissue parameters listed in the SAR test plots may slightly differ from the table above due to significant digit rounding in the software.

FCC ID: ZNFV495		SAR EVALUATION REPORT		Reviewed by: Quality Manager
Document S/N: OY1503160550.ZNF	Test Dates: 03/16/15 - 03/25/15	DUT Type: Portable Tablet		Page 48 of 70

Test System Verification

Prior to SAR assessment, the system is verified to $\pm 10\%$ of the SAR measurement on the reference dipole at the time of calibration by the calibration facility. Full system validation status and result summary can be found in Appendix E.

Table 9-2
System Verification Results

System Verification TARGET & MEASURED												
SAR System #	Tissue Frequency (MHz)	Tissue Type	Date:	Amb. Temp (°C)	Liquid Temp (°C)	Input Power (W)	Dipole SN	Probe SN	Measured SAR _{1g} (W/kg)	1 W Target SAR _{1g} (W/kg)	1 W Normalized SAR _{1g} (W/kg)	Deviation _{1g} (%)
D	750	BODY	03/24/2015	23.8	22.3	0.100	1003	3263	0.916	8.460	9.160	8.27%
K	835	BODY	03/16/2015	24.7	22.6	0.100	4d133	3288	0.999	9.350	9.990	6.84%
K	835	BODY	03/18/2015	22.8	22.5	0.100	4d119	3288	1.010	9.340	10.100	8.14%
E	1750	BODY	03/23/2015	22.4	21.8	0.100	1008	3332	3.520	37.600	35.200	-6.38%
D	1900	BODY	03/17/2015	23.7	23.0	0.100	5d149	3263	3.990	40.400	39.900	-1.24%
G	2450	BODY	03/17/2015	24.3	22.4	0.100	719	3213	5.290	51.800	52.900	2.12%
G	2450	BODY	03/25/2015	24.0	21.2	0.100	719	3213	5.510	51.800	55.100	6.37%
G	2600	BODY	03/25/2015	24.0	21.2	0.100	1071	3213	6.100	56.900	61.000	7.21%
A	5200	BODY	03/17/2015	23.1	23.0	0.050	1191	3914	3.880	77.800	77.600	-0.26%
A	5300	BODY	03/17/2015	23.3	23.0	0.050	1191	3914	3.890	79.900	77.800	-2.63%
A	5500	BODY	03/17/2015	23.4	22.9	0.050	1191	3914	4.030	83.100	80.600	-3.01%
A	5600	BODY	03/17/2015	23.4	23.0	0.050	1191	3914	3.950	84.100	79.000	-6.06%
A	5800	BODY	03/17/2015	23.2	23.0	0.050	1191	3914	3.660	78.000	73.200	-6.15%

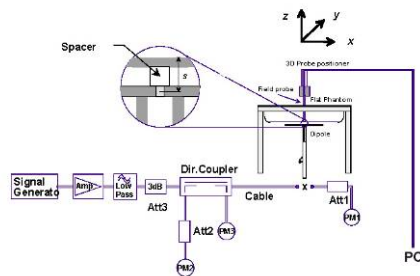



Figure 9-1
System Verification Setup Diagram



Figure 9-2
System Verification Setup Photo



FCC ID: ZNFV495	 PCTEST ENGINEERING LABORATORY, INC.	SAR EVALUATION REPORT	 LG	Reviewed by: Quality Manager
Document S/N: OY1503160550.ZNF	Test Dates: 03/16/15 - 03/25/15	DUT Type: Portable Tablet	Page 49 of 70	

10 SAR DATA SUMMARY

10.1 Standalone Body SAR Data

**Table 10-1
UMTS Body SAR Data**

MEASUREMENT RESULTS														
FREQUENCY		Mode	Service	Maximum Allowed Power [dBm]	Conducted Power [dBm]	Power Drift [dB]	Spacing	Device Serial Number	Duty Cycle	Side	SAR (1g)	Scaling Factor	Scaled SAR (1g)	Plot #
MHz	Ch.										(W/kg)		(W/kg)	
836.60	4183	UMTS 850	RMC	24.7	24.64	-0.01	22 mm	1TRPA	1:1	back	0.275	1.014	0.279	
836.60	4183	UMTS 850	RMC	24.7	24.64	0.12	19 mm	1TRPA	1:1	top	0.226	1.014	0.229	
836.60	4183	UMTS 850	RMC	24.7	24.64	-0.05	7 mm	1TRPA	1:1	right	0.352	1.014	0.357	
836.60	4183	UMTS 850	RMC	24.7	24.64	0.16	0 mm	1TRPA	1:1	left	0.211	1.014	0.214	
836.60	4183	UMTS 850	RMC	20.7	20.50	0.10	0 mm	1TRPJ	1:1	back	0.717	1.047	0.751	A1
836.60	4183	UMTS 850	RMC	20.7	20.50	0.08	0 mm	1TRPJ	1:1	top	0.301	1.047	0.315	
836.60	4183	UMTS 850	RMC	20.7	20.50	-0.02	0 mm	1TRPJ	1:1	right	0.350	1.047	0.366	
1732.40	1412	UMTS 1750	RMC	24.2	24.11	0.08	22 mm	1TRPA	1:1	back	0.217	1.021	0.222	
1732.40	1412	UMTS 1750	RMC	24.2	24.11	0.01	19 mm	1TRPA	1:1	top	0.245	1.021	0.250	
1732.40	1412	UMTS 1750	RMC	24.2	24.11	0.02	7 mm	1TRPA	1:1	right	0.183	1.021	0.187	
1732.40	1412	UMTS 1750	RMC	24.2	24.11	0.05	0 mm	1TRPA	1:1	left	0.389	1.021	0.397	
1732.40	1412	UMTS 1750	RMC	13.2	12.90	0.10	0 mm	1TRPJ	1:1	back	0.732	1.072	0.785	A2
1732.40	1412	UMTS 1750	RMC	13.2	12.90	-0.09	0 mm	1TRPJ	1:1	top	0.503	1.072	0.539	
1732.40	1412	UMTS 1750	RMC	13.2	12.90	-0.03	0 mm	1TRPJ	1:1	right	0.046	1.072	0.049	
1880.00	9400	UMTS 1900	RMC	23.7	23.65	0.07	22 mm	1TRPA	1:1	back	0.366	1.012	0.370	
1880.00	9400	UMTS 1900	RMC	23.7	23.65	-0.07	19 mm	1TRPA	1:1	top	0.414	1.012	0.419	
1880.00	9400	UMTS 1900	RMC	23.7	23.65	-0.01	7 mm	1TRPA	1:1	right	0.304	1.012	0.308	
1880.00	9400	UMTS 1900	RMC	23.7	23.65	-0.11	0 mm	1TRPA	1:1	left	0.384	1.012	0.389	
1880.00	9400	UMTS 1900	RMC	12.7	12.39	-0.15	0 mm	1TRPJ	1:1	back	0.709	1.074	0.761	A3
1880.00	9400	UMTS 1900	RMC	12.7	12.39	0.19	0 mm	1TRPJ	1:1	top	0.558	1.074	0.599	
1880.00	9400	UMTS 1900	RMC	12.7	12.39	-0.09	0 mm	1TRPJ	1:1	right	0.045	1.074	0.048	
ANSI / IEEE C95.1 1992 - SAFETY LIMIT							Body							
Spatial Peak							1.6 W/kg (mW/g)							
Uncontrolled Exposure/General Population							averaged over 1 gram							

FCC ID: ZNFV495	 PCTEST ENGINEERING LABORATORY, INC.	SAR EVALUATION REPORT	 LG	Reviewed by: Quality Manager
Document S/N: OY1503160550.ZNF	Test Dates: 03/16/15 - 03/25/15	DUT Type: Portable Tablet		Page 50 of 70

**Table 10-2
LTE Band 12 Body SAR**

MEASUREMENT RESULTS																			
FREQUENCY		Mode	Bandwidth [MHz]	Maximum Allowed Power [dBm]	Conducted Power [dBm]	Power Drift [dB]	MPR [dB]	Device Serial Number	Modulation	RB Size	RB Offset	Spacing	Side	Duty Cycle	SAR (1g)	Scaling Factor	Scaled SAR (1g)	Plot #	
MHz	Ch.														(W/kg)		(W/kg)		
707.50	23095	Mid	LTE Band 12	10	24.7	24.42	-0.02	0	1TRP7	QPSK	1	0	22 mm	back	1:1	0.179	1.067	0.191	
707.50	23095	Mid	LTE Band 12	10	23.7	23.39	0.06	1	1TRP7	QPSK	25	25	22 mm	back	1:1	0.157	1.074	0.169	
707.50	23095	Mid	LTE Band 12	10	24.7	24.42	-0.04	0	1TRP7	QPSK	1	0	19 mm	top	1:1	0.126	1.067	0.134	
707.50	23095	Mid	LTE Band 12	10	23.7	23.39	0.07	1	1TRP7	QPSK	25	25	19 mm	top	1:1	0.084	1.074	0.090	
707.50	23095	Mid	LTE Band 12	10	24.7	24.42	0.01	0	1TRP7	QPSK	1	0	7 mm	right	1:1	0.211	1.067	0.225	
707.50	23095	Mid	LTE Band 12	10	23.7	23.39	0.10	1	1TRP7	QPSK	25	25	7 mm	right	1:1	0.166	1.074	0.178	
707.50	23095	Mid	LTE Band 12	10	24.7	24.42	0.12	0	1TRP7	QPSK	1	0	0 mm	left	1:1	0.159	1.067	0.170	
707.50	23095	Mid	LTE Band 12	10	23.7	23.39	0.06	1	1TRP7	QPSK	25	25	0 mm	left	1:1	0.114	1.074	0.122	
707.50	23095	Mid	LTE Band 12	10	20.7	20.70	0.05	0	1TRP8	QPSK	1	25	0 mm	back	1:1	0.701	1.000	0.701	
707.50	23095	Mid	LTE Band 12	10	20.7	20.57	-0.01	0	1TRP8	QPSK	25	12	0 mm	back	1:1	0.718	1.030	0.740	A4
707.50	23095	Mid	LTE Band 12	10	20.7	20.70	-0.11	0	1TRP8	QPSK	1	25	0 mm	top	1:1	0.509	1.000	0.509	
707.50	23095	Mid	LTE Band 12	10	20.7	20.57	-0.15	0	1TRP8	QPSK	25	12	0 mm	top	1:1	0.502	1.030	0.517	
707.50	23095	Mid	LTE Band 12	10	20.7	20.70	0.07	0	1TRP8	QPSK	1	25	0 mm	right	1:1	0.284	1.000	0.284	
707.50	23095	Mid	LTE Band 12	10	20.7	20.57	0.15	0	1TRP8	QPSK	25	12	0 mm	right	1:1	0.285	1.030	0.294	
ANSI / IEEE C95.1 1992 - SAFETY LIMIT Spatial Peak Uncontrolled Exposure/General Population								Body 1.6 W/kg (mW/g) averaged over 1 gram											

**Table 10-3
LTE Band 5 (Cell) Body SAR**

MEASUREMENT RESULTS																			
FREQUENCY		Mode	Bandwidth [MHz]	Maximum Allowed Power [dBm]	Conducted Power [dBm]	Power Drift [dB]	MPR [dB]	Device Serial Number	Modulation	RB Size	RB Offset	Spacing	Side	Duty Cycle	SAR (1g)	Scaling Factor	Scaled SAR (1g)	Plot #	
MHz	Ch.														(W/kg)		(W/kg)		
836.50	20525	Mid	LTE Band 5 (Cell)	10	24.2	24.12	0.00	0	1TRP7	QPSK	1	49	22 mm	back	1:1	0.236	1.019	0.240	
836.50	20525	Mid	LTE Band 5 (Cell)	10	23.2	22.97	0.03	1	1TRP7	QPSK	25	12	22 mm	back	1:1	0.203	1.054	0.214	
836.50	20525	Mid	LTE Band 5 (Cell)	10	24.2	24.12	-0.02	0	1TRP7	QPSK	1	49	19 mm	top	1:1	0.186	1.019	0.190	
836.50	20525	Mid	LTE Band 5 (Cell)	10	23.2	22.97	-0.05	1	1TRP7	QPSK	25	12	19 mm	top	1:1	0.153	1.054	0.161	
836.50	20525	Mid	LTE Band 5 (Cell)	10	24.2	24.12	0.08	0	1TRP7	QPSK	1	49	7 mm	right	1:1	0.289	1.019	0.294	
836.50	20525	Mid	LTE Band 5 (Cell)	10	23.2	22.97	-0.03	1	1TRP7	QPSK	25	12	7 mm	right	1:1	0.211	1.054	0.222	
836.50	20525	Mid	LTE Band 5 (Cell)	10	24.2	24.12	0.00	0	1TRP7	QPSK	1	49	0 mm	left	1:1	0.128	1.019	0.130	
836.50	20525	Mid	LTE Band 5 (Cell)	10	23.2	22.97	0.11	1	1TRP7	QPSK	25	12	0 mm	left	1:1	0.084	1.054	0.089	
836.50	20525	Mid	LTE Band 5 (Cell)	10	20.2	20.19	-0.02	0	1TRP8	QPSK	1	49	0 mm	back	1:1	0.529	1.002	0.530	
836.50	20525	Mid	LTE Band 5 (Cell)	10	20.2	20.05	0.02	0	1TRP8	QPSK	25	25	0 mm	back	1:1	0.544	1.035	0.563	A5
836.50	20525	Mid	LTE Band 5 (Cell)	10	20.2	20.19	0.13	0	1TRP8	QPSK	1	49	0 mm	top	1:1	0.228	1.002	0.228	
836.50	20525	Mid	LTE Band 5 (Cell)	10	20.2	20.05	0.04	0	1TRP8	QPSK	25	25	0 mm	top	1:1	0.233	1.035	0.241	
836.50	20525	Mid	LTE Band 5 (Cell)	10	20.2	20.19	0.11	0	1TRP8	QPSK	1	49	0 mm	right	1:1	0.353	1.002	0.354	
836.50	20525	Mid	LTE Band 5 (Cell)	10	20.2	20.05	0.07	0	1TRP8	QPSK	25	25	0 mm	right	1:1	0.349	1.035	0.361	
ANSI / IEEE C95.1 1992 - SAFETY LIMIT Spatial Peak Uncontrolled Exposure/General Population								Body 1.6 W/kg (mW/g) averaged over 1 gram											





FCC ID: ZNFV495		SAR EVALUATION REPORT		Reviewed by: Quality Manager
Document S/N: OY1503160550.ZNF	Test Dates: 03/16/15 - 03/25/15	DUT Type: Portable Tablet	Page 51 of 70	

Table 10-4
LTE Band 4 (AWS) Body SAR

MEASUREMENT RESULTS																			
FREQUENCY		Mode	Bandwidth [MHz]	Maximum Allowed Power [dBm]	Conducted Power [dBm]	Power Drift [dB]	MPR [dB]	Device Serial Number	Modulation	RB Size	RB Offset	Spacing	Side	Duty Cycle	SAR (1g)	Scaling Factor	Scaled SAR (1g)	Plot #	
MHz	Ch.														(W/kg)		(W/kg)		
1732.50	20175	Mid	LTE Band 4 (AWS)	20	24.2	23.85	0.02	0	1TRP7	QPSK	1	0	22 mm	back	1:1	0.200	1.084	0.217	
1732.50	20175	Mid	LTE Band 4 (AWS)	20	23.2	22.86	0.10	1	1TRP7	QPSK	50	25	22 mm	back	1:1	0.164	1.081	0.177	
1732.50	20175	Mid	LTE Band 4 (AWS)	20	24.2	23.85	0.06	0	1TRP7	QPSK	1	0	19 mm	top	1:1	0.199	1.084	0.216	
1732.50	20175	Mid	LTE Band 4 (AWS)	20	23.2	22.86	-0.04	1	1TRP7	QPSK	50	25	19 mm	top	1:1	0.160	1.081	0.173	
1732.50	20175	Mid	LTE Band 4 (AWS)	20	24.2	23.85	0.01	0	1TRP7	QPSK	1	0	7 mm	right	1:1	0.212	1.084	0.230	
1732.50	20175	Mid	LTE Band 4 (AWS)	20	23.2	22.86	-0.01	1	1TRP7	QPSK	50	25	7 mm	right	1:1	0.104	1.081	0.112	
1732.50	20175	Mid	LTE Band 4 (AWS)	20	24.2	23.85	0.07	0	1TRP7	QPSK	1	0	0 mm	left	1:1	0.361	1.084	0.391	
1732.50	20175	Mid	LTE Band 4 (AWS)	20	23.2	22.86	0.04	1	1TRP7	QPSK	50	25	0 mm	left	1:1	0.293	1.081	0.317	
1732.50	20175	Mid	LTE Band 4 (AWS)	20	13.2	13.18	-0.03	0	1TRP8	QPSK	1	50	0 mm	back	1:1	0.782	1.005	0.786	A6
1732.50	20175	Mid	LTE Band 4 (AWS)	20	13.2	13.09	-0.03	0	1TRP8	QPSK	50	25	0 mm	back	1:1	0.764	1.026	0.784	
1732.50	20175	Mid	LTE Band 4 (AWS)	20	13.2	13.18	0.11	0	1TRP8	QPSK	1	50	0 mm	top	1:1	0.491	1.005	0.493	
1732.50	20175	Mid	LTE Band 4 (AWS)	20	13.2	13.09	0.12	0	1TRP8	QPSK	50	25	0 mm	top	1:1	0.495	1.026	0.508	
1732.50	20175	Mid	LTE Band 4 (AWS)	20	13.2	13.18	0.06	0	1TRP8	QPSK	1	50	0 mm	right	1:1	0.053	1.005	0.053	
1732.50	20175	Mid	LTE Band 4 (AWS)	20	13.2	13.09	0.04	0	1TRP8	QPSK	50	25	0 mm	right	1:1	0.053	1.026	0.054	
ANSI / IEEE C95.1 1992 - SAFETY LIMIT Spatial Peak Uncontrolled Exposure/General Population										Body 1.6 W/kg (mW/g) averaged over 1 gram									

Table 10-5
LTE Band 2 (PCS) Body SAR

MEASUREMENT RESULTS																			
FREQUENCY		Mode	Bandwidth [MHz]	Maximum Allowed Power [dBm]	Conducted Power [dBm]	Power Drift [dB]	MPR [dB]	Device Serial Number	Modulation	RB Size	RB Offset	Spacing	Side	Duty Cycle	SAR (1g)	Scaling Factor	Scaled SAR (1g)	Plot #	
MHz	Ch.														(W/kg)		(W/kg)		
1880.00	18900	Mid	LTE Band 2 (PCS)	20	23.7	23.70	0.05	0	1TRP7	QPSK	1	0	22 mm	back	1:1	0.364	1.000	0.364	
1880.00	18900	Mid	LTE Band 2 (PCS)	20	22.7	22.70	0.02	1	1TRP7	QPSK	50	0	22 mm	back	1:1	0.275	1.000	0.275	
1880.00	18900	Mid	LTE Band 2 (PCS)	20	23.7	23.70	0.05	0	1TRP7	QPSK	1	0	19 mm	top	1:1	0.385	1.000	0.385	
1880.00	18900	Mid	LTE Band 2 (PCS)	20	22.7	22.70	-0.09	1	1TRP7	QPSK	50	0	19 mm	top	1:1	0.291	1.000	0.291	
1880.00	18900	Mid	LTE Band 2 (PCS)	20	23.7	23.70	-0.06	0	1TRP7	QPSK	1	0	7 mm	right	1:1	0.298	1.000	0.298	
1880.00	18900	Mid	LTE Band 2 (PCS)	20	22.7	22.70	0.01	1	1TRP7	QPSK	50	0	7 mm	right	1:1	0.225	1.000	0.225	
1880.00	18900	Mid	LTE Band 2 (PCS)	20	23.7	23.70	-0.02	0	1TRP7	QPSK	1	0	0 mm	left	1:1	0.419	1.000	0.419	
1880.00	18900	Mid	LTE Band 2 (PCS)	20	22.7	22.70	0.05	1	1TRP7	QPSK	50	0	0 mm	left	1:1	0.297	1.000	0.297	
1880.00	18900	Mid	LTE Band 2 (PCS)	20	12.7	12.70	0.06	0	1TRP8	QPSK	1	50	0 mm	back	1:1	0.657	1.000	0.657	
1880.00	18900	Mid	LTE Band 2 (PCS)	20	12.7	12.64	0.00	0	1TRP8	QPSK	50	25	0 mm	back	1:1	0.657	1.014	0.666	A7
1880.00	18900	Mid	LTE Band 2 (PCS)	20	12.7	12.70	-0.04	0	1TRP8	QPSK	1	50	0 mm	top	1:1	0.538	1.000	0.538	
1880.00	18900	Mid	LTE Band 2 (PCS)	20	12.7	12.64	-0.01	0	1TRP8	QPSK	50	25	0 mm	top	1:1	0.536	1.014	0.544	
1880.00	18900	Mid	LTE Band 2 (PCS)	20	12.7	12.70	0.02	0	1TRP8	QPSK	1	50	0 mm	right	1:1	0.039	1.000	0.039	
1880.00	18900	Mid	LTE Band 2 (PCS)	20	12.7	12.64	0.05	0	1TRP8	QPSK	50	25	0 mm	right	1:1	0.041	1.014	0.042	
ANSI / IEEE C95.1 1992 - SAFETY LIMIT Spatial Peak Uncontrolled Exposure/General Population										Body 1.6 W/kg (mW/g) averaged over 1 gram									

FCC ID: ZNFV495	 PCTEST ENGINEERING LABORATORY, INC.	SAR EVALUATION REPORT		Reviewed by: Quality Manager
Document S/N: OY1503160550.ZNF	Test Dates: 03/16/15 - 03/25/15	DUT Type: Portable Tablet	Page 52 of 70	



**Table 10-6
LTE Band 7 Body SAR**

MEASUREMENT RESULTS																			
FREQUENCY		Mode	Bandwidth [MHz]	Maximum Allowed Power [dBm]	Conducted Power [dBm]	Power Drift [dB]	MPR [dB]	Device Serial Number	Modulation	RB Size	RB Offset	Spacing	Side	Duty Cycle	SAR (1g)	Scaling Factor	Scaled SAR (1g)	Plot #	
MHz	Ch.														(W/kg)		(W/kg)		
2510.00	20850	Low	LTE Band 7	20	24.2	24.02	-0.04	0	1TRP7	QPSK	1	0	22 mm	back	1:1	0.414	1.042	0.431	
2510.00	20850	Low	LTE Band 7	20	23.2	22.98	-0.02	1	1TRP7	QPSK	50	25	22 mm	back	1:1	0.311	1.052	0.327	
2510.00	20850	Low	LTE Band 7	20	24.2	24.02	-0.09	0	1TRP7	QPSK	1	0	19 mm	top	1:1	0.623	1.042	0.649	
2510.00	20850	Low	LTE Band 7	20	23.2	22.98	0.01	1	1TRP7	QPSK	50	25	19 mm	top	1:1	0.483	1.052	0.508	
2510.00	20850	Low	LTE Band 7	20	24.2	24.02	0.08	0	1TRP7	QPSK	1	0	7 mm	right	1:1	1.130	1.042	1.177	
2535.00	21100	Mid	LTE Band 7	20	24.2	23.95	-0.03	0	1TRP7	QPSK	1	99	7 mm	right	1:1	0.945	1.059	1.001	
2560.00	21350	High	LTE Band 7	20	24.2	23.83	0.10	0	1TRP7	QPSK	1	0	7 mm	right	1:1	0.928	1.089	1.011	
2510.00	20850	Low	LTE Band 7	20	23.2	22.98	0.09	1	1TRP7	QPSK	50	25	7 mm	right	1:1	0.843	1.052	0.887	
2535.00	21100	Mid	LTE Band 7	20	23.2	22.82	0.09	1	1TRP7	QPSK	50	50	7 mm	right	1:1	0.749	1.091	0.817	
2560.00	21350	High	LTE Band 7	20	23.2	22.94	-0.01	1	1TRP7	QPSK	50	25	7 mm	right	1:1	0.624	1.062	0.663	
2560.00	21350	High	LTE Band 7	20	23.2	22.96	0.07	1	1TRP7	QPSK	100	0	7 mm	right	1:1	0.680	1.057	0.719	
2510.00	20850	Low	LTE Band 7	20	24.2	24.02	0.01	0	1TRP7	QPSK	1	0	0 mm	left	1:1	0.086	1.042	0.090	
2510.00	20850	Low	LTE Band 7	20	23.2	22.98	-0.16	1	1TRP7	QPSK	50	25	0 mm	left	1:1	0.068	1.052	0.072	
2535.00	21100	Mid	LTE Band 7	20	9.2	9.09	-0.03	0	1TRP8	QPSK	1	50	0 mm	back	1:1	0.357	1.026	0.366	
2535.00	21100	Mid	LTE Band 7	20	9.2	9.02	-0.08	0	1TRP8	QPSK	50	25	0 mm	back	1:1	0.347	1.042	0.362	
2535.00	21100	Mid	LTE Band 7	20	9.2	9.09	-0.13	0	1TRP8	QPSK	1	50	0 mm	top	1:1	0.380	1.026	0.390	
2535.00	21100	Mid	LTE Band 7	20	9.2	9.02	-0.13	0	1TRP8	QPSK	50	25	0 mm	top	1:1	0.360	1.042	0.375	
2535.00	21100	Mid	LTE Band 7	20	9.2	9.09	0.10	0	1TRP8	QPSK	1	50	0 mm	right	1:1	0.103	1.026	0.106	
2535.00	21100	Mid	LTE Band 7	20	9.2	9.02	0.07	0	1TRP8	QPSK	50	25	0 mm	right	1:1	0.088	1.042	0.092	
2510.00	20850	Low	LTE Band 7	20	24.2	24.02	0.02	0	1TRP7	QPSK	1	0	7 mm	right	1:1	1.170	1.042	1.219	A8
2535.00	21100	Mid	LTE Band 7	20	24.2	23.95	0.05	0	1TRP7	QPSK	1	99	7 mm	right	1:1	0.998	1.059	1.057	
ANSI / IEEE C95.1 1992 - SAFETY LIMIT Spatial Peak Uncontrolled Exposure/General Population										Body 1.6 W/kg (mW/g) averaged over 1 gram									

Note: Blue entry represents variability measurement.

**Table 10-7
DTS Body SAR**

MEASUREMENT RESULTS																
FREQUENCY		Mode	Service	Bandwidth [MHz]	Maximum Allowed Power [dBm]	Conducted Power [dBm]	Power Drift [dB]	Spacing	Device Serial Number	Data Rate (Mbps)	Side	Duty Cycle	SAR (1g)	Scaling Factor	Scaled SAR (1g)	Plot #
MHz	Ch.												(W/kg)		(W/kg)	
2437	6	IEEE 802.11b	DSSS	22	13.0	12.05	-0.05	0 mm	1TRNY	1	back	1:1	0.377	1.245	0.469	A9
2437	6	IEEE 802.11n	OFDM	20	10.0	9.03	-0.05	0 mm	1TRNY	6.5	back	1:1	0.151	1.250	0.189	
2437	6	IEEE 802.11b	DSSS	22	13.0	12.05	0.05	0 mm	1TRNY	1	top	1:1	0.162	1.245	0.202	
2437	6	IEEE 802.11b	DSSS	22	13.0	12.05	0.04	0 mm	1TRNY	1	right	1:1	0.010	1.245	0.012	
2437	6	IEEE 802.11b	DSSS	22	13.0	12.05	0.13	0 mm	1TRNY	1	left	1:1	0.101	1.245	0.126	
ANSI / IEEE C95.1 1992 - SAFETY LIMIT Spatial Peak Uncontrolled Exposure/General Population										Body 1.6 W/kg (mW/g) averaged over 1 gram						



FCC ID: ZNFV495	 PCTEST ENGINEERING LABORATORY, INC.	SAR EVALUATION REPORT		Reviewed by: Quality Manager
Document S/N: OY1503160550.ZNF	Test Dates: 03/16/15 - 03/25/15	DUT Type: Portable Tablet		Page 53 of 70

**Table 10-8
UNII Body SAR**

MEASUREMENT RESULTS																
FREQUENCY		Mode	Service	Bandwidth [MHz]	Maximum Allowed Power [dBm]	Conducted Power [dBm]	Power Drift [dB]	Spacing	Device Serial Number	Data Rate (Mbps)	Side	Duty Cycle	SAR (1g)	Scaling Factor	Scaled SAR (1g)	Plot #
MHz	Ch.												(W/kg)		(W/kg)	
5180	36	IEEE 802.11a	OFDM	20	10.0	9.26	0.10	0 mm	1TRNW	6	back	1:1	0.339	1.186	0.402	
5180	36	IEEE 802.11a	OFDM	20	10.0	9.26	0.18	0 mm	1TRNW	6	top	1:1	0.379	1.186	0.449	
5180	36	IEEE 802.11a	OFDM	20	10.0	9.26	-0.05	0 mm	1TRNW	6	right	1:1	0.001	1.186	0.001	
5180	36	IEEE 802.11a	OFDM	20	10.0	9.26	0.20	0 mm	1TRNW	6	left	1:1	0.088	1.186	0.104	
5280	56	IEEE 802.11a	OFDM	20	10.0	9.22	0.07	0 mm	1TRNW	6	back	1:1	0.400	1.197	0.479	
5300	60	IEEE 802.11a	OFDM	20	10.0	9.17	-0.03	0 mm	1TRNW	6	back	1:1	0.425	1.211	0.515	A10
5280	56	IEEE 802.11n	OFDM	20	9.0	8.40	0.11	0 mm	1TRNW	6.5	back	1:1	0.197	1.148	0.226	
5270	54	IEEE 802.11n	OFDM	40	8.0	6.87	0.03	0 mm	1TRNW	13.5	back	1:1	0.135	1.297	0.175	
5280	56	IEEE 802.11a	OFDM	20	10.0	9.22	0.03	0 mm	1TRNW	6	top	1:1	0.350	1.197	0.419	
5280	56	IEEE 802.11a	OFDM	20	10.0	9.22	0.07	0 mm	1TRNW	6	right	1:1	0.004	1.197	0.005	
5280	56	IEEE 802.11a	OFDM	20	10.0	9.22	0.03	0 mm	1TRNW	6	left	1:1	0.086	1.197	0.103	
5500	100	IEEE 802.11a	OFDM	20	10.0	9.11	0.07	0 mm	1TRNW	6	back	1:1	0.412	1.227	0.506	
5580	116	IEEE 802.11a	OFDM	20	10.0	9.13	0.16	0 mm	1TRNW	6	back	1:1	0.362	1.222	0.442	
5700	140	IEEE 802.11a	OFDM	20	10.0	8.87	0.16	0 mm	1TRNW	6	back	1:1	0.298	1.297	0.387	
5500	100	IEEE 802.11n	OFDM	20	9.0	8.24	0.09	0 mm	1TRNW	6.5	back	1:1	0.156	1.191	0.186	
5510	102	IEEE 802.11n	OFDM	40	8.0	6.54	0.07	0 mm	1TRNW	13.5	back	1:1	0.084	1.400	0.118	
5580	116	IEEE 802.11a	OFDM	20	10.0	9.13	-0.01	0 mm	1TRNW	6	top	1:1	0.279	1.222	0.341	
5580	116	IEEE 802.11a	OFDM	20	10.0	9.13	0.02	0 mm	1TRNW	6	right	1:1	0.005	1.222	0.006	
5580	116	IEEE 802.11a	OFDM	20	10.0	9.13	0.13	0 mm	1TRNW	6	left	1:1	0.067	1.222	0.082	
5785	157	IEEE 802.11a	OFDM	20	10.0	9.24	0.13	0 mm	1TRNW	6	back	1:1	0.262	1.191	0.312	
5785	157	IEEE 802.11a	OFDM	20	10.0	9.24	0.09	0 mm	1TRNW	6	top	1:1	0.270	1.191	0.322	
5805	161	IEEE 802.11n	OFDM	20	9.0	7.85	0.20	0 mm	1TRNW	6.5	top	1:1	0.081	1.303	0.106	
5755	151	IEEE 802.11n	OFDM	40	8.0	6.60	0.06	0 mm	1TRNW	13.5	top	1:1	0.075	1.380	0.104	
5785	157	IEEE 802.11a	OFDM	20	10.0	9.24	0.04	0 mm	1TRNW	6	right	1:1	0.007	1.191	0.008	
5785	157	IEEE 802.11a	OFDM	20	10.0	9.24	0.09	0 mm	1TRNW	6	left	1:1	0.061	1.191	0.073	
ANSI / IEEE C95.1 1992 - SAFETY LIMIT Spatial Peak Uncontrolled Exposure/General Population								Body 1.6 W/kg (mW/g) averaged over 1 gram								

**Table 10-9
Bluetooth Body SAR**

MEASUREMENT RESULTS															
FREQUENCY		Mode	Service	Maximum Allowed Power [dBm]	Conducted Power [dBm]	Power Drift [dB]	Spacing	Device Serial Number	Data Rate (Mbps)	Side	Duty Cycle	SAR (1g)	Scaling Factor	Scaled SAR (1g)	Plot #
MHz	Ch.											(W/kg)		(W/kg)	
2441	39	Bluetooth	FHSS	9.5	8.31	0.02	0 mm	1TRNY	1	back	1:1	0.031	1.315	0.041	A11
2441	39	Bluetooth	FHSS	9.5	8.31	0.10	0 mm	1TRNY	1	top	1:1	0.021	1.315	0.028	
2441	39	Bluetooth	FHSS	9.5	8.31	0.00	0 mm	1TRNY	1	right	1:1	0.000	1.315	0.000	
2441	39	Bluetooth	FHSS	9.5	8.31	-0.15	0 mm	1TRNY	1	left	1:1	0.012	1.315	0.016	
ANSI / IEEE C95.1 1992 - SAFETY LIMIT Spatial Peak Uncontrolled Exposure/General Population								Body 1.6 W/kg (mW/g) averaged over 1 gram							

FCC ID: ZNFV495	 PCTEST ENGINEERING LABORATORY, INC.	SAR EVALUATION REPORT		Reviewed by: Quality Manager
Document S/N: OY1503160550.ZNF	Test Dates: 03/16/15 - 03/25/15	DUT Type: Portable Tablet		Page 54 of 70

10.2 SAR Test Notes

General Notes:



1. The test data reported are the worst-case SAR values according to test procedures specified in IEEE 1528-2003, and FCC KDB Publication 447498 D01v05.
2. Batteries are fully charged at the beginning of the SAR measurements.
3. Liquid tissue depth was at least 15.0 cm for all frequencies.
4. The manufacturer has confirmed that the device(s) tested have the same physical, mechanical and thermal characteristics and are within operational tolerances expected for production units.
5. SAR results were scaled to the maximum allowed power to demonstrate compliance per FCC KDB Publication 447498 D01v05.
6. Per FCC KDB 865664 D01 v01, variability SAR tests were required for LTE B7 since the measured SAR results were > 0.8 W/kg. Please see Section 12 for more information.
7. Per FCC KDB 616217 D04 Section 4.3, SAR tests are required for the back surface and edges of the tablet with the tablet touching the phantom. The SAR Exclusion Threshold in FCC KDB 447498 D01v05 was applied to determine SAR test exclusion for adjacent edge configurations. SAR tests were required for top, right, and left edges for the main antenna and top and left edges for the BT/WLAN antenna. Additionally, right edge was tested for BT/WLAN per the manufactures request.

UMTS Notes:

1. UMTS mode in was tested under RMC 12.2 kbps with HSPA Inactive per KDB Publication 941225 D01v03. HSPA SAR was not required since the average output power of the HSPA subtests was not more than 0.25 dB higher than the RMC level and SAR was less than 1.2 W/kg.
2. Per FCC KDB Publication 447498 D01v05, if the reported (scaled) SAR measured at the middle channel or highest output power channel for each test configuration is ≤ 0.8 W/kg then testing at the other channels is not required for such test configuration(s). When the maximum output power variation across the required test channels is $> \frac{1}{2}$ dB, instead of the middle channel, the highest output power channel was used.



LTE Notes:

1. LTE Considerations: LTE test configurations are determined according to SAR Evaluation Considerations for LTE Devices in FCC KDB Publication 941225 D05v02r03. The general test procedures used for testing can be found in Section 7.2.4.
2. MPR is permanently implemented for this device by the manufacturer. The specific manufacturer target MPR is indicated alongside the SAR results. MPR is enabled for this device, according to 3GPP TS36.101 Section 6.2.3 – 6.2.5 under Table 6.2.3-1.
3. A-MPR was disabled for all SAR tests by setting NS=01 on the base station simulator. SAR tests were performed with the same number of RB and RB offsets transmitting on all TTI frames (maximum TTI).
4. Per FCC Guidance, LTE CA SAR was not required for testing since the data sent by uplink on the uplink physical channels does not change between Rel. 8 and Rel. 10.

FCC ID: ZNFV495	 PCTEST ENGINEERING LABORATORY, INC.	SAR EVALUATION REPORT		Reviewed by: Quality Manager
Document S/N: OY1503160550.ZNF	Test Dates: 03/16/15 - 03/25/15	DUT Type: Portable Tablet	Page 55 of 70	

WLAN Notes:

1. Justification for reduced test configurations for WIFI channels per KDB Publication 248227 D01v01r02 and October 2012 FCC/TCB Meeting Notes for 2.4 GHz WIFI operations: Highest average RF output power channel for the lowest data rate was selected for SAR evaluation in 802.11b. Other IEEE 802.11 modes (including 802.11 g/n) were not required for testing since the average output powers over all channels and data rates were not more than 0.25 dB higher than the tested channel in the lowest data rate of IEEE 802.11b mode. Additional 802.11n tests were included in this report per manufacturer request.
2. Justification for reduced test configurations for WIFI channels per KDB Publication 248227 D01v01r02 and October 2012 FCC/TCB Meeting Notes for 5 GHz WIFI operations: Highest average RF output power channel for the lowest data rate was selected for SAR evaluation in 802.11a. Other IEEE 802.11 modes (including 802.11n 20 MHz and 40 MHz bandwidths) were not required for testing since the average output powers over all channels and data rates were not more than 0.25 dB higher than the tested channel in the lowest data rate of IEEE 802.11a mode. Additional 802.11n tests were included in this report per manufacturer request.
3. WIFI transmission was verified using an uncalibrated spectrum analyzer.
4. When the maximum extrapolated peak SAR of the zoom scan for the maximum output channel is >1.6 W/kg or the reported 1g averaged SAR is >0.8 W/kg, SAR testing on other default channels was required.
5. There is no sensor power reduction mechanism applied for WIFI/BT modes.

FCC ID: ZNFV495	 SAR EVALUATION REPORT 		Reviewed by: Quality Manager
Document S/N: 0Y1503160550.ZNF	Test Dates: 03/16/15 - 03/25/15	DUT Type: Portable Tablet	Page 56 of 70

11 FCC MULTI-TX AND ANTENNA SAR CONSIDERATIONS

11.1 Introduction

The following procedures adopted from FCC KDB Publication 447498 D01v05 are applicable to handsets with built-in unlicensed transmitters such as 802.11a/b/g/n and Bluetooth devices which may simultaneously transmit with the licensed transmitter.

11.2 Simultaneous Transmission Procedures

This device contains transmitters that may operate simultaneously. Therefore simultaneous transmission analysis is required. Per FCC KDB 447498 D01v05 IV.C.1.iii and IEEE 1528-2013 Section 6.3.4.1.2, simultaneous transmission SAR test exclusion may be applied when the sum of the 1-g SAR for all the simultaneous transmitting antennas in a specific physical test configuration is ≤ 1.6 W/kg. When standalone SAR is not required to be measured, per FCC KDB 447498 D01v05 4.3.2 2), the following equation must be used to estimate the standalone 1g SAR for simultaneous transmission assessment involving that transmitter.

$$\text{Estimated SAR} = \frac{\sqrt{f(\text{GHz})}}{7.5} * \frac{(\text{Max Power of channel, mW})}{\text{Min. Separation Distance, mm}}$$

**Table 11-1
Estimated SAR**

Mode	Configuration	Frequency	Maximum Allowed Power	Separation Distance (Body)	Estimated SAR (Body)
		[MHz]	[dBm]	[mm]	[W/kg]
Bluetooth LE	Back Side*	2480	0.50	5	0.042
Bluetooth LE	Top Edge*	2480	0.50	5	0.042
Bluetooth LE	Left Edge*	2480	0.50	5	0.042

Note:

1. Per KDB Publication 447498 D01v05, the maximum power of the channel was rounded to the nearest mW before calculation.
2. (*) – Per FCC KDB 447498, when the test separation distance is < 5 mm, a distance of 5 mm is applied to determine estimated SAR.
3. When the test separation distance was > 50 mm, an estimated SAR of 0.4 W/kg was used to determine simultaneous transmission SAR exclusion, for configurations excluded per FCC KDB Publication 447498 D01v05.

11.3 Body SAR Simultaneous Transmission Analysis

Note: for SAR summations for body at 2.2 cm, 1.9 cm, and 0.7 cm 2.4GHz WLAN/Bluetooth and 5 GHz WLAN SAR values for 0.0 cm were used since the 0.0 cm test distance for 2.4 GHz WLAN/Bluetooth and 5 GHz WLAN were more conservative. “<” denotes that the 0.0 cm 2.4 GHz WLAN/Bluetooth and 5 GHz WLAN SAR values were used for summation purposes.



FCC ID: ZNFV495	 PCTEST ENGINEERING LABORATORY, INC.	SAR EVALUATION REPORT		Reviewed by: Quality Manager
Document S/N: OY1503160550.ZNF	Test Dates: 03/16/15 - 03/25/15	DUT Type: Portable Tablet		Page 57 of 70

Table 11-2
Simultaneous Transmission Scenario with 2.4 GHz WLAN (Body at 0.0 cm)

Simult Tx	Configuration	UMTS 850 SAR (W/kg)	2.4 GHz WLAN SAR (W/kg)	Σ SAR (W/kg)	Simult Tx	Configuration	UMTS 1750 SAR (W/kg)	2.4 GHz WLAN SAR (W/kg)	Σ SAR (W/kg)
Body SAR	Back	0.751	0.469	1.220	Body SAR	Back	0.785	0.469	1.254
	Top	0.315	0.202	0.517		Top	0.539	0.202	0.741
	Right	0.366	0.012	0.378		Right	0.049	0.012	0.061
	Left	0.214	0.126	0.340		Left	0.397	0.126	0.523
Simult Tx	Configuration	UMTS 1900 SAR (W/kg)	2.4 GHz WLAN SAR (W/kg)	Σ SAR (W/kg)	Simult Tx	Configuration	LTE Band 12 SAR (W/kg)	2.4 GHz WLAN SAR (W/kg)	Σ SAR (W/kg)
Body SAR	Back	0.761	0.469	1.230	Body SAR	Back	0.740	0.469	1.209
	Top	0.599	0.202	0.801		Top	0.517	0.202	0.719
	Right	0.048	0.012	0.060		Right	0.294	0.012	0.306
	Left	0.389	0.126	0.515		Left	0.170	0.126	0.296
Simult Tx	Configuration	LTE Band 5 (Cell) SAR (W/kg)	2.4 GHz WLAN SAR (W/kg)	Σ SAR (W/kg)	Simult Tx	Configuration	LTE Band 4 (AWS) SAR (W/kg)	2.4 GHz WLAN SAR (W/kg)	Σ SAR (W/kg)
Body SAR	Back	0.563	0.469	1.032	Body SAR	Back	0.786	0.469	1.255
	Top	0.241	0.202	0.443		Top	0.508	0.202	0.710
	Right	0.361	0.012	0.373		Right	0.054	0.012	0.066
	Left	0.130	0.126	0.256		Left	0.391	0.126	0.517
Simult Tx	Configuration	LTE Band 2 (PCS) SAR (W/kg)	2.4 GHz WLAN SAR (W/kg)	Σ SAR (W/kg)	Simult Tx	Configuration	LTE Band 7 SAR (W/kg)	2.4 GHz WLAN SAR (W/kg)	Σ SAR (W/kg)
Body SAR	Back	0.666	0.469	1.135	Body SAR	Back	0.366	0.469	0.835
	Top	0.544	0.202	0.746		Top	0.390	0.202	0.592
	Right	0.042	0.012	0.054		Right	0.106	0.012	0.118
	Left	0.419	0.126	0.545		Left	0.090	0.126	0.216



FCC ID: ZNFV495		SAR EVALUATION REPORT		Reviewed by: Quality Manager
Document S/N: OY1503160550.ZNF	Test Dates: 03/16/15 - 03/25/15	DUT Type: Portable Tablet	Page 58 of 70	

Table 11-3
Simultaneous Transmission Scenario with 5 GHz WLAN (Body at 0.0 cm)

Simult Tx	Configuration	UMTS 850 SAR (W/kg)	5 GHz WLAN SAR (W/kg)	Σ SAR (W/kg)	Simult Tx	Configuration	UMTS 1750 SAR (W/kg)	5 GHz WLAN SAR (W/kg)	Σ SAR (W/kg)
Body SAR	Back	0.751	0.515	1.266	Body SAR	Back	0.785	0.515	1.300
	Top	0.315	0.449	0.764		Top	0.539	0.449	0.988
	Right	0.366	0.008	0.374		Right	0.049	0.008	0.057
	Left	0.214	0.104	0.318		Left	0.397	0.104	0.501
Simult Tx	Configuration	UMTS 1900 SAR (W/kg)	5 GHz WLAN SAR (W/kg)	Σ SAR (W/kg)	Simult Tx	Configuration	LTE Band 12 SAR (W/kg)	5 GHz WLAN SAR (W/kg)	Σ SAR (W/kg)
Body SAR	Back	0.761	0.515	1.276	Body SAR	Back	0.740	0.515	1.255
	Top	0.599	0.449	1.048		Top	0.517	0.449	0.966
	Right	0.048	0.008	0.056		Right	0.294	0.008	0.302
	Left	0.389	0.104	0.493		Left	0.170	0.104	0.274
Simult Tx	Configuration	LTE Band 5 (Cell) SAR (W/kg)	5 GHz WLAN SAR (W/kg)	Σ SAR (W/kg)	Simult Tx	Configuration	LTE Band 4 (AWS) SAR (W/kg)	5 GHz WLAN SAR (W/kg)	Σ SAR (W/kg)
Body SAR	Back	0.563	0.515	1.078	Body SAR	Back	0.786	0.515	1.301
	Top	0.241	0.449	0.690		Top	0.508	0.449	0.957
	Right	0.361	0.008	0.369		Right	0.054	0.008	0.062
	Left	0.130	0.104	0.234		Left	0.391	0.104	0.495
Simult Tx	Configuration	LTE Band 2 (PCS) SAR (W/kg)	5 GHz WLAN SAR (W/kg)	Σ SAR (W/kg)	Simult Tx	Configuration	LTE Band 7 SAR (W/kg)	5 GHz WLAN SAR (W/kg)	Σ SAR (W/kg)
Body SAR	Back	0.666	0.515	1.181	Body SAR	Back	0.366	0.515	0.881
	Top	0.544	0.449	0.993		Top	0.390	0.449	0.839
	Right	0.042	0.008	0.050		Right	0.106	0.008	0.114
	Left	0.419	0.104	0.523		Left	0.090	0.104	0.194



FCC ID: ZNFV495	 PCTEST <small>ENGINEERING LABORATORY, INC.</small>	SAR EVALUATION REPORT		Reviewed by: Quality Manager
Document S/N: 0Y1503160550.ZNF	Test Dates: 03/16/15 - 03/25/15	DUT Type: Portable Tablet	Page 59 of 70	

Table 11-4
Simultaneous Transmission Scenario with Bluetooth/Bluetooth LE (Body at 0.0 cm)

Simult Tx	Configuration	UMTS 850 SAR (W/kg)	Bluetooth/Bluetooth LE SAR (W/kg)	Σ SAR (W/kg)	Simult Tx	Configuration	UMTS 1750 SAR (W/kg)	Bluetooth/Bluetooth LE SAR (W/kg)	Σ SAR (W/kg)
Body SAR	Back*	0.751	0.042	0.793	Body SAR	Back*	0.785	0.042	0.827
	Top*	0.315	0.042	0.357		Top*	0.539	0.042	0.581
	Right	0.366	0.000	0.366		Right	0.049	0.000	0.049
	Left*	0.214	0.042	0.256		Left*	0.397	0.042	0.439
Simult Tx	Configuration	UMTS 1900 SAR (W/kg)	Bluetooth/Bluetooth LE SAR (W/kg)	Σ SAR (W/kg)	Simult Tx	Configuration	LTE Band 12 SAR (W/kg)	Bluetooth/Bluetooth LE SAR (W/kg)	Σ SAR (W/kg)
Body SAR	Back*	0.761	0.042	0.803	Body SAR	Back*	0.740	0.042	0.782
	Top*	0.599	0.042	0.641		Top*	0.517	0.042	0.559
	Right	0.048	0.000	0.048		Right	0.294	0.000	0.294
	Left*	0.389	0.042	0.431		Left*	0.170	0.042	0.212
Simult Tx	Configuration	LTE Band 5 (Cell) SAR (W/kg)	Bluetooth/Bluetooth LE SAR (W/kg)	Σ SAR (W/kg)	Simult Tx	Configuration	LTE Band 4 (AWS) SAR (W/kg)	Bluetooth/Bluetooth LE SAR (W/kg)	Σ SAR (W/kg)
Body SAR	Back*	0.563	0.042	0.605	Body SAR	Back*	0.786	0.042	0.828
	Top*	0.241	0.042	0.283		Top*	0.508	0.042	0.550
	Right	0.361	0.000	0.361		Right	0.054	0.000	0.054
	Left*	0.130	0.042	0.172		Left*	0.391	0.042	0.433
Simult Tx	Configuration	LTE Band 2 (PCS) SAR (W/kg)	Bluetooth/Bluetooth LE SAR (W/kg)	Σ SAR (W/kg)	Simult Tx	Configuration	LTE Band 7 SAR (W/kg)	Bluetooth/Bluetooth LE SAR (W/kg)	Σ SAR (W/kg)
Body SAR	Back*	0.666	0.042	0.708	Body SAR	Back*	0.366	0.042	0.408
	Top*	0.544	0.042	0.586		Top*	0.390	0.042	0.432
	Right	0.042	0.000	0.042		Right	0.106	0.000	0.106
	Left*	0.419	0.042	0.461		Left*	0.090	0.042	0.132

*Bluetooth LE SAR was not required to be measured per FCC KDB 447498. Estimated Bluetooth LE SAR results were used for Top Edge, Back Side and Left Edge to determine simultaneous transmission SAR test exclusion as it was a more conservative measurement than measured Bluetooth SAR.

Table 11-5
Simultaneous Transmission Scenario with 2.4 GHz WLAN (Body at 2.2 cm)

Configuration	Mode	3G/4G SAR (W/kg)	2.4 GHz WLAN SAR (W/kg)	Σ SAR (W/kg)
Back Side	UMTS 850	0.279	<0.469	<0.748
Back Side	UMTS 1750	0.222	<0.469	<0.691
Back Side	UMTS 1900	0.370	<0.469	<0.839
Back Side	LTE Band 12	0.191	<0.469	<0.660
Back Side	LTE Band 5 (Cell)	0.240	<0.469	<0.709
Back Side	LTE Band 4 (AWS)	0.217	<0.469	<0.686
Back Side	LTE Band 2 (PCS)	0.364	<0.469	<0.833
Back Side	LTE Band 7	0.431	<0.469	<0.900



FCC ID: ZNFV495	 SAR EVALUATION REPORT		Reviewed by: Quality Manager
Document S/N: OY1503160550.ZNF	Test Dates: 03/16/15 - 03/25/15	DUT Type: Portable Tablet	Page 60 of 70

Table 11-6
Simultaneous Transmission Scenario with 5 GHz WLAN (Body at 2.2 cm)

Configuration	Mode	3G/4G SAR (W/kg)	5 GHz WLAN SAR (W/kg)	Σ SAR (W/kg)
Back Side	UMTS 850	0.279	<0.515	<0.794
Back Side	UMTS 1750	0.222	<0.515	<0.737
Back Side	UMTS 1900	0.370	<0.515	<0.885
Back Side	LTE Band 12	0.191	<0.515	<0.706
Back Side	LTE Band 5 (Cell)	0.240	<0.515	<0.755
Back Side	LTE Band 4 (AWS)	0.217	<0.515	<0.732
Back Side	LTE Band 2 (PCS)	0.364	<0.515	<0.879
Back Side	LTE Band 7	0.431	<0.515	<0.946

Table 11-7
Simultaneous Transmission Scenario with Bluetooth (Body at 2.2 cm)

Configuration	Mode	3G/4G SAR (W/kg)	Bluetooth SAR (W/kg)	Σ SAR (W/kg)
Back Side	UMTS 850	0.279	<0.041	<0.320
Back Side	UMTS 1750	0.222	<0.041	<0.263
Back Side	UMTS 1900	0.370	<0.041	<0.411
Back Side	LTE Band 12	0.191	<0.041	<0.232
Back Side	LTE Band 5 (Cell)	0.240	<0.041	<0.281
Back Side	LTE Band 4 (AWS)	0.217	<0.041	<0.258
Back Side	LTE Band 2 (PCS)	0.364	<0.041	<0.405
Back Side	LTE Band 7	0.431	<0.041	<0.472

Table 11-8
Simultaneous Transmission Scenario with 2.4 GHz WLAN (Body at 1.9 cm)

Configuration	Mode	3G/4G SAR (W/kg)	2.4 GHz WLAN SAR (W/kg)	Σ SAR (W/kg)
Top Edge	UMTS 850	0.229	<0.202	<0.431
Top Edge	UMTS 1750	0.250	<0.202	<0.452
Top Edge	UMTS 1900	0.419	<0.202	<0.621
Top Edge	LTE Band 12	0.134	<0.202	<0.336
Top Edge	LTE Band 5 (Cell)	0.190	<0.202	<0.392
Top Edge	LTE Band 4 (AWS)	0.216	<0.202	<0.418
Top Edge	LTE Band 2 (PCS)	0.385	<0.202	<0.587
Top Edge	LTE Band 7	0.649	<0.202	<0.851



FCC ID: ZNFV495		SAR EVALUATION REPORT		Reviewed by: Quality Manager
Document S/N: OY1503160550.ZNF	Test Dates: 03/16/15 - 03/25/15	DUT Type: Portable Tablet		Page 61 of 70

Table 11-9
Simultaneous Transmission Scenario with 5 GHz WLAN (Body at 1.9 cm)

Configuration	Mode	3G/4G SAR (W/kg)	5 GHz WLAN SAR (W/kg)	Σ SAR (W/kg)
Top Edge	UMTS 850	0.229	<0.449	<0.678
Top Edge	UMTS 1750	0.250	<0.449	<0.699
Top Edge	UMTS 1900	0.419	<0.449	<0.868
Top Edge	LTE Band 12	0.134	<0.449	<0.583
Top Edge	LTE Band 5 (Cell)	0.190	<0.449	<0.639
Top Edge	LTE Band 4 (AWS)	0.216	<0.449	<0.665
Top Edge	LTE Band 2 (PCS)	0.385	<0.449	<0.834
Top Edge	LTE Band 7	0.649	<0.449	<1.098

Table 11-10
Simultaneous Transmission Scenario with Bluetooth (Body at 1.9 cm)

Configuration	Mode	3G/4G SAR (W/kg)	Bluetooth SAR (W/kg)	Σ SAR (W/kg)
Top Edge	UMTS 850	0.229	<0.028	<0.257
Top Edge	UMTS 1750	0.250	<0.028	<0.278
Top Edge	UMTS 1900	0.419	<0.028	<0.447
Top Edge	LTE Band 12	0.134	<0.028	<0.162
Top Edge	LTE Band 5 (Cell)	0.190	<0.028	<0.218
Top Edge	LTE Band 4 (AWS)	0.216	<0.028	<0.244
Top Edge	LTE Band 2 (PCS)	0.385	<0.028	<0.413
Top Edge	LTE Band 7	0.649	<0.028	<0.677

Table 11-11
Simultaneous Transmission Scenario with 2.4 GHz WLAN (Body at 0.7 cm)

Configuration	Mode	3G/4G SAR (W/kg)	2.4 GHz WLAN SAR (W/kg)	Σ SAR (W/kg)
Right Edge	UMTS 850	0.357	<0.012	<0.369
Right Edge	UMTS 1750	0.187	<0.012	<0.199
Right Edge	UMTS 1900	0.308	<0.012	<0.320
Right Edge	LTE Band 12	0.225	<0.012	<0.237
Right Edge	LTE Band 5 (Cell)	0.294	<0.012	<0.306
Right Edge	LTE Band 4 (AWS)	0.230	<0.012	<0.242
Right Edge	LTE Band 2 (PCS)	0.298	<0.012	<0.310
Right Edge	LTE Band 7	1.219	<0.012	<1.231



FCC ID: ZNFV495		SAR EVALUATION REPORT		Reviewed by: Quality Manager
Document S/N: OY1503160550.ZNF	Test Dates: 03/16/15 - 03/25/15	DUT Type: Portable Tablet		Page 62 of 70

Table 11-12
Simultaneous Transmission Scenario with 5 GHz WLAN (Body at 0.7 cm)



Configuration	Mode	3G/4G SAR (W/kg)	5 GHz WLAN SAR (W/kg)	Σ SAR (W/kg)
Right Edge	UMTS 850	0.357	<0.008	<0.365
Right Edge	UMTS 1750	0.187	<0.008	<0.195
Right Edge	UMTS 1900	0.308	<0.008	<0.316
Right Edge	LTE Band 12	0.225	<0.008	<0.233
Right Edge	LTE Band 5 (Cell)	0.294	<0.008	<0.302
Right Edge	LTE Band 4 (AWS)	0.230	<0.008	<0.238
Right Edge	LTE Band 2 (PCS)	0.298	<0.008	<0.306
Right Edge	LTE Band 7	1.219	<0.008	<1.227

Table 11-13
Simultaneous Transmission Scenario with Bluetooth (Body at 0.7 cm)

Configuration	Mode	3G/4G SAR (W/kg)	Bluetooth SAR (W/kg)	Σ SAR (W/kg)
Right Edge	UMTS 850	0.357	0.000	0.357
Right Edge	UMTS 1750	0.187	0.000	0.187
Right Edge	UMTS 1900	0.308	0.000	0.308
Right Edge	LTE Band 12	0.225	0.000	0.225
Right Edge	LTE Band 5 (Cell)	0.294	0.000	0.294
Right Edge	LTE Band 4 (AWS)	0.230	0.000	0.230
Right Edge	LTE Band 2 (PCS)	0.298	0.000	0.298
Right Edge	LTE Band 7	1.219	0.000	1.219

11.4 Simultaneous Transmission Conclusion

The above numerical summed SAR results for all the worst-case simultaneous transmission conditions were below the SAR limit. Therefore, the above analysis is sufficient to determine that simultaneous transmission cases will not exceed the SAR limit and therefore no measured volumetric simultaneous SAR summation is required per FCC KDB Publication 447498 D01v05 and IEEE 1528-2013 Section 6.3.4.1.2.

FCC ID: ZNFV495		SAR EVALUATION REPORT		Reviewed by: Quality Manager
Document S/N: OY1503160550.ZNF	Test Dates: 03/16/15 - 03/25/15	DUT Type: Portable Tablet	Page 63 of 70	

12 SAR MEASUREMENT VARIABILITY

12.1 Measurement Variability

Per FCC KDB Publication 865664 D01v01, SAR measurement variability was assessed for each frequency band, which was determined by the SAR probe calibration point and tissue-equivalent medium used for the device measurements. When both head and body tissue-equivalent media were required for SAR measurements in a frequency band, the variability measurement procedures were applied to the tissue medium with the highest measured SAR, using the highest measured SAR configuration for that tissue-equivalent medium. These additional measurements were repeated after the completion of all measurements requiring the same head or body tissue-equivalent medium in a frequency band. The test device was returned to ambient conditions (normal room temperature) with the battery fully charged before it was re-mounted on the device holder for the repeated measurement(s) to minimize any unexpected variations in the repeated results.

SAR Measurement Variability was assessed using the following procedures for each frequency band:



- 1) When the original highest measured SAR is ≥ 0.80 W/kg, the measurement was repeated once.
- 2) A second repeated measurement was performed only if the ratio of largest to smallest SAR for the original and first repeated measurements was > 1.20 or when the original or repeated measurement was ≥ 1.45 W/kg (~ 10% from the 1-g SAR limit).
- 3) A third repeated measurement was performed only if the original, first or second repeated measurement was ≥ 1.5 W/kg and the ratio of largest to smallest SAR for the original, first and second repeated measurements is > 1.20 .
- 4) Repeated measurements are not required when the original highest measured SAR is < 0.80 W/kg

**Table 12-1
Body SAR Measurement Variability Results**

BODY VARIABILITY RESULTS													
Band	FREQUENCY		Mode	Service	Side	Spacing	Measured SAR (1g)	1st Repeated SAR (1g)	Ratio	2nd Repeated SAR (1g)	Ratio	3rd Repeated SAR (1g)	Ratio
	MHz	Ch.					(W/kg)	(W/kg)		(W/kg)		(W/kg)	
2450	2510.00	20850	LTE Band 7	QPSK, 1 RB, 0 RB Offset	right	7 mm	1.130	1.170	1.04	N/A	N/A	N/A	N/A
2600	2535.00	21100	LTE Band 7	QPSK, 1 RB, 99 RB Offset	right	7 mm	0.945	0.998	1.06	N/A	N/A	N/A	N/A
ANSI / IEEE C95.1 1992 - SAFETY LIMIT Spatial Peak Uncontrolled Exposure/General Population						Body 1.6 W/kg (mW/g) averaged over 1 gram							

12.2 Measurement Uncertainty



The measured SAR was < 1.5 W/kg for all frequency bands. Therefore, per KDB Publication 865664 D01v01, the extended measurement uncertainty analysis per IEEE 1528-2003 was not required.

FCC ID: ZNFV495	 PCTEST ENGINEERING LABORATORY, INC.	SAR EVALUATION REPORT		Reviewed by: Quality Manager
Document S/N: OY1503160550.ZNF	Test Dates: 03/16/15 - 03/25/15	DUT Type: Portable Tablet	Page 64 of 70	

13 EQUIPMENT LIST

Manufacturer	Model	Description	Cal Date	Cal Interval	Cal Due	Serial Number
Agilent	E8257D	(250kHz-20GHz) Signal Generator	4/15/2014	Annual	4/15/2015	MY45470194
Agilent	N4010A	Wireless Connectivity Test Set	N/A	N/A	N/A	GB46170464
Agilent	8753E	(30kHz-6GHz) Network Analyzer	12/30/2014	Annual	12/30/2015	JP38020182
Agilent	8594A	(9kHz-2.9GHz) Spectrum Analyzer	N/A	N/A	N/A	3051A00187
Agilent	8648D	(9kHz-4GHz) Signal Generator	4/15/2014	Annual	4/15/2015	3629U00687
Agilent	E4407B	ESA Spectrum Analyzer	4/16/2014	Annual	4/16/2015	US39210313
Agilent	E4438C	ESG Vector Signal Generator	4/15/2014	Annual	4/15/2015	MY45090700
Agilent	E4432B	ESG-D Series Signal Generator	4/15/2014	Annual	4/15/2015	US40053896
Agilent	N9020A	MXA Signal Analyzer	10/27/2014	Annual	10/27/2015	US46470561
Agilent	N5182A	MXG Vector Signal Generator	4/15/2014	Annual	4/15/2015	MY47420800
Agilent	N5182A	MXG Vector Signal Generator	4/15/2014	Annual	4/15/2015	MY47420651
Agilent	8753ES	S-Parameter Network Analyzer	5/22/2014	Annual	5/22/2015	US39170118
Agilent	E5515C	Wireless Communications Test Set	12/24/2014	Annual	12/24/2015	GB44400860
Amplifier Research	15S1G6	Amplifier	CBT	N/A	CBT	433971
Amplifier Research	15S1G6	Amplifier	CBT	N/A	CBT	433972
Anritsu	ML2495A	Power Meter	10/31/2013	Biennial	10/31/2015	941001
Anritsu	MA2411B	Pulse Power Sensor	11/17/2014	Annual	11/17/2015	1207364
Anritsu	MA2411B	Pulse Power Sensor	11/17/2014	Annual	11/17/2015	1126066
Anritsu	MT8820C	Radio Communication Analyzer	5/6/2014	Annual	5/6/2015	6201144419
Anritsu	MT8820C	Radio Communication Analyzer	8/28/2014	Annual	8/28/2015	6201240328
Anritsu	MA24106A	USB Power Sensor	5/15/2014	Annual	5/15/2015	1244524
Anritsu	MA24106A	USB Power Sensor	5/15/2014	Annual	5/15/2015	1244512
COMTECH	AR85729-5/5759B	Solid State Amplifier	CBT	N/A	CBT	M3W1A00-1002
COMTECH	AR85729-5	Solid State Amplifier	CBT	N/A	CBT	M155A00-009
Control Company	4052	Long Stem Thermometer	9/27/2013	Biennial	9/27/2015	130567447
Control Company	61220-416	Long-Stem Thermometer	4/29/2014	Biennial	4/29/2016	111331323
Control Company	36934-158	Wall-Mounted Thermometer	4/29/2014	Biennial	4/29/2016	122014488
MCL	BW-N6W5+	6dB Attenuator	CBT	N/A	CBT	1139
MiniCircuits	VLF-6000+	Low Pass Filter	CBT	N/A	CBT	N/A
Mini-Circuits	BW-N20W5+	DC to 18 GHz Precision Fixed 20 dB Attenuator	CBT	N/A	CBT	N/A
Mini-Circuits	NLP-1200+	Low Pass Filter DC to 1000 MHz	CBT	N/A	CBT	N/A
Mini-Circuits	NLP-2950+	Low Pass Filter DC to 2700 MHz	CBT	N/A	CBT	N/A
Mini-Circuits	BW-N20W5	Power Attenuator	CBT	N/A	CBT	1226
Mitutoyo	CD-6°CSX	Digital Caliper	5/8/2014	Biennial	5/8/2016	13264162
Narda	4014C-6	4 - 8 GHz SMA 6 dB Directional Coupler	CBT	N/A	CBT	N/A
Narda	BW-53W2	Attenuator (3dB)	CBT	N/A	CBT	120
Pasternack	PE2208-6	Bidirectional Coupler	CBT	N/A	CBT	N/A
Pasternack	PE2209-10	Bidirectional Coupler	CBT	N/A	CBT	N/A
Rohde & Schwarz	CMW500	Radio Communication Tester	4/17/2014	Annual	4/17/2015	101699
Rohde & Schwarz	CMW500	Radio Communication Tester	4/17/2014	Annual	4/17/2015	102060
Rohde & Schwarz	CMW500	Radio Communication Tester	4/23/2014	Annual	4/23/2015	112347
Seekonk	NC-100	Torque Wrench	3/18/2014	Biennial	3/18/2016	22313
Seekonk	NC-100	Torque Wrench 5/16", 8" lbs	3/18/2014	Biennial	3/18/2016	N/A
SPEAG	D1765V2	1765 MHz SAR Dipole	5/7/2014	Annual	5/7/2015	1008
SPEAG	D835V2	835 MHz SAR Dipole	4/7/2014	Annual	4/7/2015	4d119
SPEAG	D2600V2	2600 MHz SAR Dipole	10/20/2014	Annual	10/20/2015	1071
SPEAG	D750V3	750 MHz Dipole	1/16/2015	Annual	1/16/2016	1003
SPEAG	D1900V2	1900 MHz SAR Dipole	7/23/2014	Annual	7/23/2015	5d149
SPEAG	D2450V2	2450 MHz SAR Dipole	8/11/2014	Annual	8/11/2015	719
SPEAG	D835V2	835 MHz SAR Dipole	7/24/2014	Annual	7/24/2015	4d133
SPEAG	D5GHzV2	5 MHz SAR Dipole	9/25/2014	Annual	9/25/2015	1191
SPEAG	D4E4	Dasy Data Acquisition Electronics	10/31/2014	Annual	10/31/2015	1333
SPEAG	D4E4	Dasy Data Acquisition Electronics	1/19/2015	Annual	1/19/2016	1407
SPEAG	D4E4	Dasy Data Acquisition Electronics	5/14/2014	Annual	5/14/2015	859
SPEAG	D4E4	Dasy Data Acquisition Electronics	9/17/2014	Annual	9/17/2015	1323
SPEAG	D4E4	Dasy Data Acquisition Electronics	9/18/2014	Annual	9/18/2015	1364
SPEAG	DAK-3.5	Dielectric Assessment Kit	5/6/2014	Annual	5/6/2015	1070
SPEAG	ES3DV3	SAR Probe	9/18/2014	Annual	9/18/2015	3332
SPEAG	ES3DV3	SAR Probe	1/20/2015	Annual	1/20/2016	3213
SPEAG	ES3DV3	SAR Probe	5/15/2014	Annual	5/15/2015	3263
SPEAG	EX3DV4	SAR Probe	2/10/2015	Annual	2/10/2016	3914
SPEAG	ES3DV3	SAR Probe	9/24/2014	Annual	9/24/2015	3288
Tektronix	RSA6114A	Real Time Spectrum Analyzer	4/16/2014	Annual	4/16/2015	8010177
VWR	36934-158	Wall-Mounted Thermometer	8/8/2013	Biennial	8/8/2015	130477877

Note: CBT (Calibrated Before Testing). Prior to testing, the measurement paths containing a cable, amplifier, attenuator, coupler or filter were connected to a calibrated source (i.e. a signal generator) to determine the losses of the measurement path. The power meter offset was then adjusted to compensate for the measurement system losses. This level offset is stored within the power meter before measurements are made. This calibration verification procedure applies to the system verification and output power measurements. The calibrated reading is then taken directly from the power meter after compensation of the losses for all final power measurements.



FCC ID: ZNFV495	 PCTEST ENGINEERING LABORATORY, INC.	SAR EVALUATION REPORT		Reviewed by: Quality Manager
Document S/N: OY1503160550.ZNF	Test Dates: 03/16/15 - 03/25/15	DUT Type: Portable Tablet	Page 65 of 70	

14 MEASUREMENT UNCERTAINTIES

Applicable for frequencies less than 3000 MHz.

a	b	c	d	e= f(d,k)	f	g	h = c x f/e	i = c x g/e	k
Uncertainty Component	IEEE 1528 Sec.	Tol. (± %)	Prob. Dist.	Div.	c _i 1gm	c _i 10 gms	1gm u _i (± %)	10gms u _i (± %)	v _i
Measurement System									
Probe Calibration	E.2.1	6.0	N	1	1.0	1.0	6.0	6.0	∞
Axial Isotropy	E.2.2	0.25	N	1	0.7	0.7	0.2	0.2	∞
Hemishperical Isotropy	E.2.2	1.3	N	1	1.0	1.0	1.3	1.3	∞
Boundary Effect	E.2.3	0.4	N	1	1.0	1.0	0.4	0.4	∞
Linearity	E.2.4	0.3	N	1	1.0	1.0	0.3	0.3	∞
System Detection Limits	E.2.5	5.1	N	1	1.0	1.0	5.1	5.1	∞
Readout Electronics	E.2.6	1.0	N	1	1.0	1.0	1.0	1.0	∞
Response Time	E.2.7	0.8	R	1.73	1.0	1.0	0.5	0.5	∞
Integration Time	E.2.8	2.6	R	1.73	1.0	1.0	1.5	1.5	∞
RF Ambient Conditions	E.6.1	3.0	R	1.73	1.0	1.0	1.7	1.7	∞
Probe Positioner Mechanical Tolerance	E.6.2	0.4	R	1.73	1.0	1.0	0.2	0.2	∞
Probe Positioning w/ respect to Phantom	E.6.3	2.9	R	1.73	1.0	1.0	1.7	1.7	∞
Extrapolation, Interpolation & Integration algorithms for Max. SAR Evaluation	E.5	1.0	R	1.73	1.0	1.0	0.6	0.6	∞
Test Sample Related									
Test Sample Positioning	E.4.2	6.0	N	1	1.0	1.0	6.0	6.0	287
Device Holder Uncertainty	E.4.1	3.32	R	1.73	1.0	1.0	1.9	1.9	∞
Output Power Variation - SAR drift measurement	6.6.2	5.0	R	1.73	1.0	1.0	2.9	2.9	∞
Phantom & Tissue Parameters									
Phantom Uncertainty (Shape & Thickness tolerances)	E.3.1	4.0	R	1.73	1.0	1.0	2.3	2.3	∞
Liquid Conductivity - deviation from target values	E.3.2	5.0	R	1.73	0.64	0.43	1.8	1.2	∞
Liquid Conductivity - measurement uncertainty	E.3.3	3.8	N	1	0.64	0.43	2.4	1.6	6
Liquid Permittivity - deviation from target values	E.3.2	5.0	R	1.73	0.60	0.49	1.7	1.4	∞
Liquid Permittivity - measurement uncertainty	E.3.3	4.5	N	1	0.60	0.49	2.7	2.2	6
Combined Standard Uncertainty (k=1)	RSS						12.1	11.7	299
Expanded Uncertainty (95% CONFIDENCE LEVEL)	k=2						24.2	23.5	



The above measurement uncertainties are according to IEEE Std. 1528-2003

FCC ID: ZNFV495	 PCTEST ENGINEERING LABORATORY, INC.	SAR EVALUATION REPORT		Reviewed by: Quality Manager
Document S/N: OY1503160550.ZNF	Test Dates: 03/16/15 - 03/25/15	DUT Type: Portable Tablet	Page 66 of 70	

Applicable for frequencies up to 6 GHz.

a	b	c	d	e= f(d,k)	f	g	h = c x f/e	i = c x g/e	k	
Uncertainty Component	IEEE 1528 Sec.	Tol. (± %)	Prob. Dist.	Div.	c _i 1gm	c _i 10 gms	1gm u _i (± %)	10gms u _i (± %)	v _i	
Measurement System										
Probe Calibration	E.2.1	6.55	N	1	1.0	1.0	6.6	6.6	∞	
Axial Isotropy	E.2.2	0.25	N	1	0.7	0.7	0.2	0.2	∞	
Hemishperical Isotropy	E.2.2	1.3	N	1	1.0	1.0	1.3	1.3	∞	
Boundary Effect	E.2.3	0.4	N	1	1.0	1.0	0.4	0.4	∞	
Linearity	E.2.4	0.3	N	1	1.0	1.0	0.3	0.3	∞	
System Detection Limits	E.2.5	5.1	N	1	1.0	1.0	5.1	5.1	∞	
Readout Electronics	E.2.6	1.0	N	1	1.0	1.0	1.0	1.0	∞	
Response Time	E.2.7	0.8	R	1.73	1.0	1.0	0.5	0.5	∞	
Integration Time	E.2.8	2.6	R	1.73	1.0	1.0	1.5	1.5	∞	
RF Ambient Conditions	E.6.1	3.0	R	1.73	1.0	1.0	1.7	1.7	∞	
Probe Positioner Mechanical Tolerance	E.6.2	0.4	R	1.73	1.0	1.0	0.2	0.2	∞	
Probe Positioning w/ respect to Phantom	E.6.3	2.9	R	1.73	1.0	1.0	1.7	1.7	∞	
Extrapolation, Interpolation & Integration algorithms for Max. SAR Evaluation	E.5	1.0	R	1.73	1.0	1.0	0.6	0.6	∞	
Test Sample Related										
Test Sample Positioning	E.4.2	6.0	N	1	1.0	1.0	6.0	6.0	287	
Device Holder Uncertainty	E.4.1	3.32	R	1.73	1.0	1.0	1.9	1.9	∞	
Output Power Variation - SAR drift measurement	6.6.2	5.0	R	1.73	1.0	1.0	2.9	2.9	∞	
Phantom & Tissue Parameters										
Phantom Uncertainty (Shape & Thickness tolerances)	E.3.1	4.0	R	1.73	1.0	1.0	2.3	2.3	∞	
Liquid Conductivity - deviation from target values	E.3.2	5.0	R	1.73	0.64	0.43	1.8	1.2	∞	
Liquid Conductivity - measurement uncertainty	E.3.3	3.8	N	1	0.64	0.43	2.4	1.6	6	
Liquid Permittivity - deviation from target values	E.3.2	5.0	R	1.73	0.60	0.49	1.7	1.4	∞	
Liquid Permittivity - measurement uncertainty	E.3.3	4.5	N	1	0.60	0.49	2.7	2.2	6	
Combined Standard Uncertainty (k=1)							RSS	12.4	12.0	299
Expanded Uncertainty (95% CONFIDENCE LEVEL)							k=2	24.7	24.0	

The above measurement uncertainties are according to IEEE Std. 1528-2003



FCC ID: ZNFV495	 PCTEST ENGINEERING LABORATORY, INC.	SAR EVALUATION REPORT		Reviewed by: Quality Manager
Document S/N: OY1503160550.ZNF	Test Dates: 03/16/15 - 03/25/15	DUT Type: Portable Tablet	Page 67 of 70	

15 CONCLUSION

15.1 Measurement Conclusion



The SAR evaluation indicates that the EUT complies with the RF radiation exposure limits of the FCC and Industry Canada, with respect to all parameters subject to this test. These measurements were taken to simulate the RF effects of RF exposure under worst-case conditions. Precise laboratory measures were taken to assure repeatability of the tests. The results and statements relate only to the item(s) tested.

Please note that the absorption and distribution of electromagnetic energy in the body are very complex phenomena that depend on the mass, shape, and size of the body, the orientation of the body with respect to the field vectors, and the electrical properties of both the body and the environment. Other variables that may play a substantial role in possible biological effects are those that characterize the environment (e.g. ambient temperature, air velocity, relative humidity, and body insulation) and those that characterize the individual (e.g. age, gender, activity level, debilitation, or disease). Because various factors may interact with one another to vary the specific biological outcome of an exposure to electromagnetic fields, any protection guide should consider maximal amplification of biological effects as a result of field-body interactions, environmental conditions, and physiological variables. [3]



FCC ID: ZNFV495	 PCTEST ENGINEERING LABORATORY, INC.	SAR EVALUATION REPORT	 LG	Reviewed by: Quality Manager
Document S/N: 0Y1503160550.ZNF	Test Dates: 03/16/15 - 03/25/15	DUT Type: Portable Tablet	Page 68 of 70	

16 REFERENCES

- [1] Federal Communications Commission, ET Docket 93-62, Guidelines for Evaluating the Environmental Effects of Radiofrequency Radiation, Aug. 1996.
- [2] ANSI/IEEE C95.1-2005, American National Standard safety levels with respect to human exposure to radio frequency electromagnetic fields, 3kHz to 300GHz, New York: IEEE, 2006.
- [3] ANSI/IEEE C95.1-1992, American National Standard safety levels with respect to human exposure to radio frequency electromagnetic fields, 3kHz to 300GHz, New York: IEEE, Sept. 1992.
- [4] ANSI/IEEE C95.3-2002, IEEE Recommended Practice for the Measurement of Potentially Hazardous Electromagnetic Fields - RF and Microwave, New York: IEEE, December 2002.
- [5] IEEE Standards Coordinating Committee 39 –Standards Coordinating Committee 34 – IEEE Std. 1528-2003, Recommended Practice for Determining the Peak Spatial-Average Specific Absorption Rate (SAR) in the Human Head Due to Wireless Communications Devices: Measurement Techniques.
- [6] NCRP, National Council on Radiation Protection and Measurements, Biological Effects and Exposure Criteria for RadioFrequency Electromagnetic Fields, NCRP Report No. 86, 1986. Reprinted Feb. 1995.
- [7] T. Schmid, O. Egger, N. Kuster, Automated E-field scanning system for dosimetric assessments, IEEE Transaction on Microwave Theory and Techniques, vol. 44, Jan. 1996, pp. 105-113.
- [8] K. Pokovic, T. Schmid, N. Kuster, Robust setup for precise calibration of E-field probes in tissue simulating liquids at mobile communications frequencies, ICECOM97, Oct. 1997, pp. 1-124.
- [9] K. Pokovic, T. Schmid, and N. Kuster, E-field Probe with improved isotropy in brain simulating liquids, Proceedings of the ELMAR, Zadar, Croatia, June 23-25, 1996, pp. 172-175.
- [10] Schmid & Partner Engineering AG, Application Note: Data Storage and Evaluation, June 1998, p2.
- [11] V. Hombach, K. Meier, M. Burkhardt, E. Kuhn, N. Kuster, The Dependence of EM Energy Absorption upon Human Modeling at 900 MHz, IEEE Transaction on Microwave Theory and Techniques, vol. 44 no. 10, Oct. 1996, pp. 1865-1873.
- [12] N. Kuster and Q. Balzano, Energy absorption mechanism by biological bodies in the near field of dipole antennas above 300MHz, IEEE Transaction on Vehicular Technology, vol. 41, no. 1, Feb. 1992, pp. 17-23.
- [13] G. Hartsgrove, A. Kraszewski, A. Surowiec, Simulated Biological Materials for Electromagnetic Radiation Absorption Studies, University of Ottawa, Bioelectromagnetics, Canada: 1987, pp. 29-36.
- [14] Q. Balzano, O. Garay, T. Manning Jr., Electromagnetic Energy Exposure of Simulated Users of Portable Cellular Telephones, IEEE Transactions on Vehicular Technology, vol. 44, no.3, Aug. 1995.
- [15] W. Gander, Computermathematick, Birkhaeuser, Basel, 1992.
- [16] W.H. Press, S.A. Teukolsky, W.T. Vetterling, and B.P. Flannery, Numerical Recipes in C, The Art of Scientific Computing, Second edition, Cambridge University Press, 1992.
- [17] N. Kuster, R. Kastle, T. Schmid, Dosimetric evaluation of mobile communications equipment with known precision, IEEE Transaction on Communications, vol. E80-B, no. 5, May 1997, pp. 645-652.

FCC ID: ZNFV495	 PCTEST ENGINEERING LABORATORY, INC.	SAR EVALUATION REPORT		Reviewed by: Quality Manager
Document S/N: OY1503160550.ZNF	Test Dates: 03/16/15 - 03/25/15	DUT Type: Portable Tablet	Page 69 of 70	

- [18] CENELEC CLC/SC111B, European Prestandard (prENV 50166-2), Human Exposure to Electromagnetic Fields High-frequency: 10kHz-300GHz, Jan. 1995.
- [19] Prof. Dr. Niels Kuster, ETH, Eidgenössische Technische Hochschule Zürich, Dosimetric Evaluation of the Cellular Phone.
- [20] IEC 62209-1, Human exposure to radio frequency fields from hand-held and body-mounted wireless communication devices - Human models, instrumentation, and procedures - Part 1: Procedure to determine the specific absorption rate (SAR) for hand-held devices used in close proximity to the ear (frequency range of 300 MHz to 3 GHz), Feb. 2005.
- [21] Industry Canada RSS-102 Radio Frequency Exposure Compliance of Radiocommunication Apparatus (All Frequency Bands) Issue 4, March 2010.
- [22] Health Canada Safety Code 6 Limits of Human Exposure to Radio Frequency Electromagnetic Fields in the Frequency Range from 3 kHz – 300 GHz, 2009
- [23] FCC SAR Test Procedures for 2G-3G Devices, Mobile Hotspot and UMPC Devices KDB Publications 941225, D01-D07
- [24] SAR Measurement procedures for IEEE 802.11a/b/g KDB Publication 248227 D01v01r02
- [25] FCC SAR Considerations for Handsets with Multiple Transmitters and Antennas, KDB Publications 648474 D02-D04
- [26] FCC SAR Evaluation Considerations for Laptop, Notebook, Netbook and Tablet Computers, FCC KDB Publication 616217 D04
- [27] FCC SAR Measurement and Reporting Requirements for 100MHz – 6 GHz, KDB Publications 865664 D01-D02
- [28] FCC General RF Exposure Guidance and SAR Procedures for Dongles, KDB Publication 447498, D01-D02
- [29] Anexo à Resolução No. 533, de 10 de Setembro de 2009.
- [30] IEC 62209-2, Human exposure to radio frequency fields from hand-held and body-mounted wireless communication devices - Human models, instrumentation, and procedures - Part 2: Procedure to determine the specific absorption rate (SAR) for wireless communication devices used in close proximity to the human body (frequency range of 30 MHz to 6 GHz), Mar. 2010.

FCC ID: ZNFV495	 SAR EVALUATION REPORT 		Reviewed by: Quality Manager
Document S/N: 0Y1503160550.ZNF	Test Dates: 03/16/15 - 03/25/15	DUT Type: Portable Tablet	Page 70 of 70

APPENDIX A: SAR TEST DATA

PCTEST ENGINEERING LABORATORY, INC.

DUT: ZNFV495; Type: Portable Tablet; Serial: 1TRPJ

Communication System: UID 0, UMTS; Frequency: 836.6 MHz; Duty Cycle: 1:1
Medium: 835 Body Medium parameters used (interpolated):
 $f = 836.6 \text{ MHz}$; $\sigma = 1.011 \text{ S/m}$; $\epsilon_r = 54.517$; $\rho = 1000 \text{ kg/m}^3$
Phantom section: Flat Section; Space: 0.0 cm

Test Date: 03-18-2015; Ambient Temp: 22.8°C; Tissue Temp: 22.5°C

Probe: ES3DV3 - SN3288; ConvF(6.32, 6.32, 6.32); Calibrated: 9/24/2014;
Sensor-Surface: 3mm (Mechanical Surface Detection)
Electronics: DAE4 Sn1364; Calibrated: 9/18/2014
Phantom: ELI v5.0; Type: QDOVA001BB; Serial: 1229
Measurement SW: DASY52, Version 52.8 (8); SEMCAD X Version 14.6.10 (7331)

Mode: UMTS 850, Body SAR, Back Side, Mid.ch

Area Scan (13x19x1): Measurement grid: dx=15mm, dy=15mm

Zoom Scan (7x7x7)/Cube 0: Measurement grid: dx=8mm, dy=8mm, dz=5mm

Reference Value = 22.99 V/m; Power Drift = 0.10 dB

Peak SAR (extrapolated) = 1.46 W/kg

SAR(1 g) = 0.717 W/kg

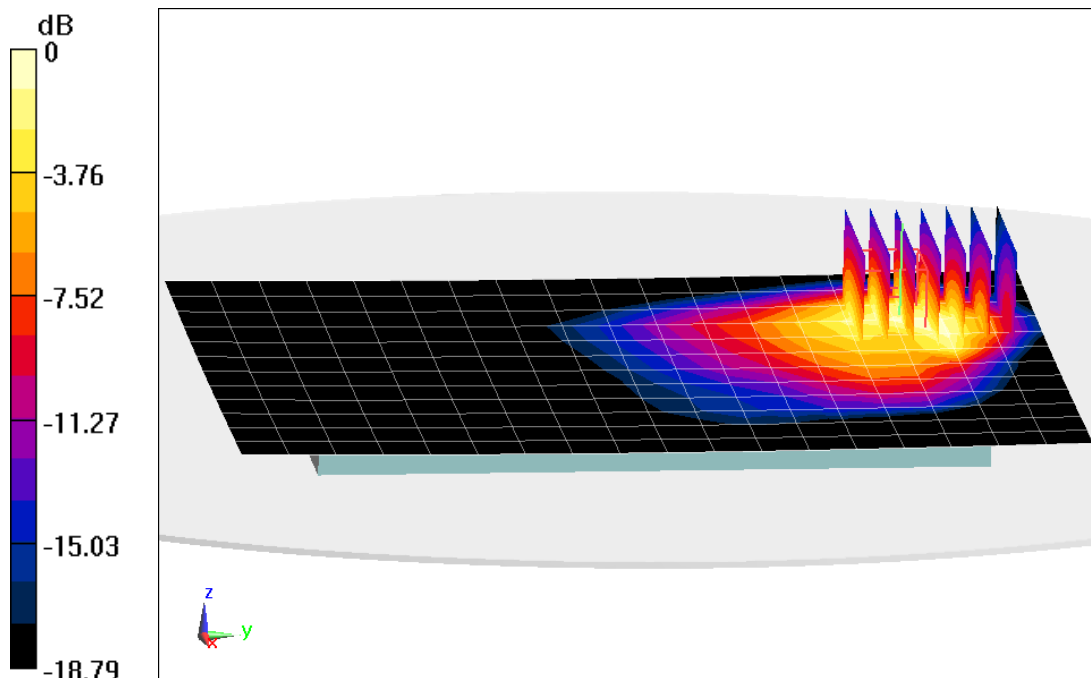

0 dB = 0.957 W/kg = -0.19 dBW/kg

PCTEST ENGINEERING LABORATORY, INC.

DUT: ZNFV495; Type: Portable Tablet; Serial: 1TRPJ

Communication System: UID 0, UMTS; Frequency: 1732.4 MHz; Duty Cycle: 1:1
Medium: 1750 Body Medium parameters used (interpolated):
 $f = 1732.4 \text{ MHz}$; $\sigma = 1.457 \text{ S/m}$; $\epsilon_r = 52.227$; $\rho = 1000 \text{ kg/m}^3$
Phantom section: Flat Section; Space: 0.0 cm

Test Date: 03-23-2015; Ambient Temp: 22.4°C; Tissue Temp: 21.8°C

Probe: ES3DV3 - SN3332; ConvF(4.88, 4.88, 4.88); Calibrated: 9/18/2014;
Sensor-Surface: 3mm (Mechanical Surface Detection)
Electronics: DAE4 Sn1323; Calibrated: 9/17/2014
Phantom: SAM 5.0 front; Type: QD000P40CD; Serial: TP:-1648
Measurement SW: DASY52, Version 52.8 (8); SEMCAD X Version 14.6.10 (7331)

Mode: AWS UMTS, Body SAR, Back side, Mid.ch

Area Scan (11x17x1): Measurement grid: dx=15mm, dy=15mm

Zoom Scan (5x5x7)/Cube 0: Measurement grid: dx=8mm, dy=8mm, dz=5mm

Reference Value = 22.37 V/m; Power Drift = 0.10 dB

Peak SAR (extrapolated) = 1.47 W/kg

SAR(1 g) = 0.732 W/kg

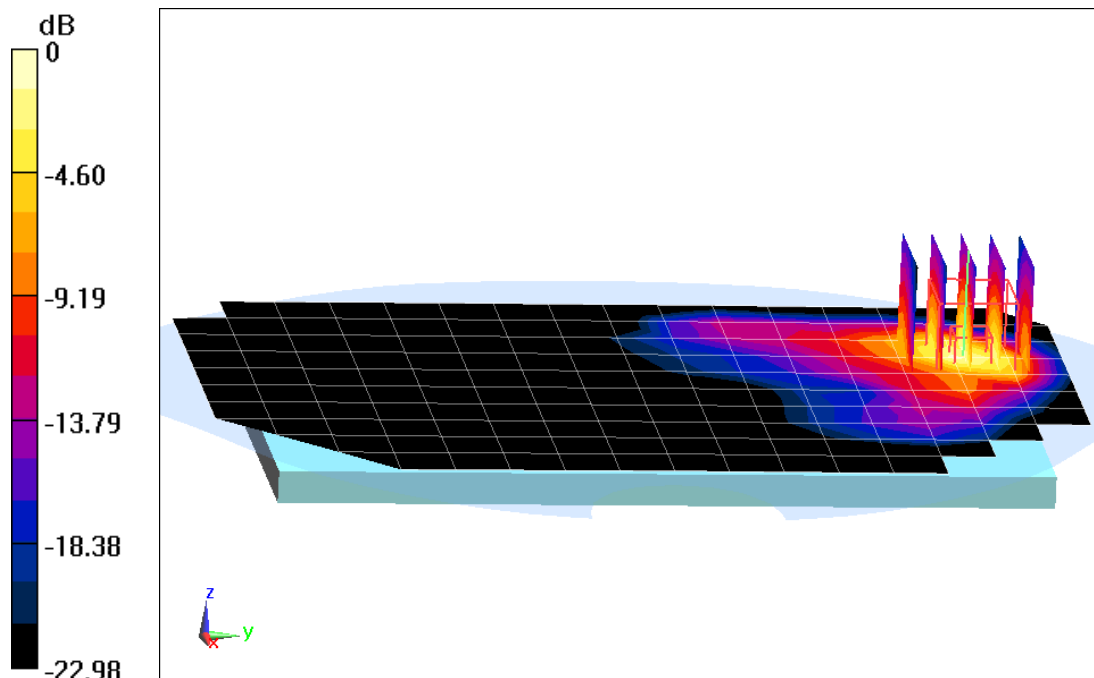

0 dB = 0.989 W/kg = -0.05 dBW/kg

PCTEST ENGINEERING LABORATORY, INC.

DUT: ZNFV495; Type: Portable Tablet; Serial: 1TRPJ

Communication System: UID 0, UMTS; Frequency: 1880 MHz; Duty Cycle: 1:1
Medium: 1900 Body Medium parameters used:
 $f = 1880 \text{ MHz}$; $\sigma = 1.548 \text{ S/m}$; $\epsilon_r = 51.527$; $\rho = 1000 \text{ kg/m}^3$
Phantom section: Flat Section; Space: 0.0 cm

Test Date: 03-17-2015; Ambient Temp: 23.7°C; Tissue Temp: 23.0°C

Probe: ES3DV3 - SN3263; ConvF(4.78, 4.78, 4.78); Calibrated: 5/15/2014;
Sensor-Surface: 3mm (Mechanical Surface Detection)
Electronics: DAE4 Sn859; Calibrated: 5/14/2014
Phantom: SAM v5.0 front; Type: QD000P40CD; Serial: TP-1646
Measurement SW: DASY52, Version 52.8 (8); SEMCAD X Version 14.6.10 (7331)

Mode: UMTS 1900, Body SAR, Back side, Mid.ch

Area Scan (12x18x1): Measurement grid: dx=15mm, dy=15mm

Zoom Scan (5x5x7)/Cube 0: Measurement grid: dx=8mm, dy=8mm, dz=5mm

Reference Value = 21.12 V/m; Power Drift = -0.15 dB

Peak SAR (extrapolated) = 1.50 W/kg

SAR(1 g) = 0.709 W/kg

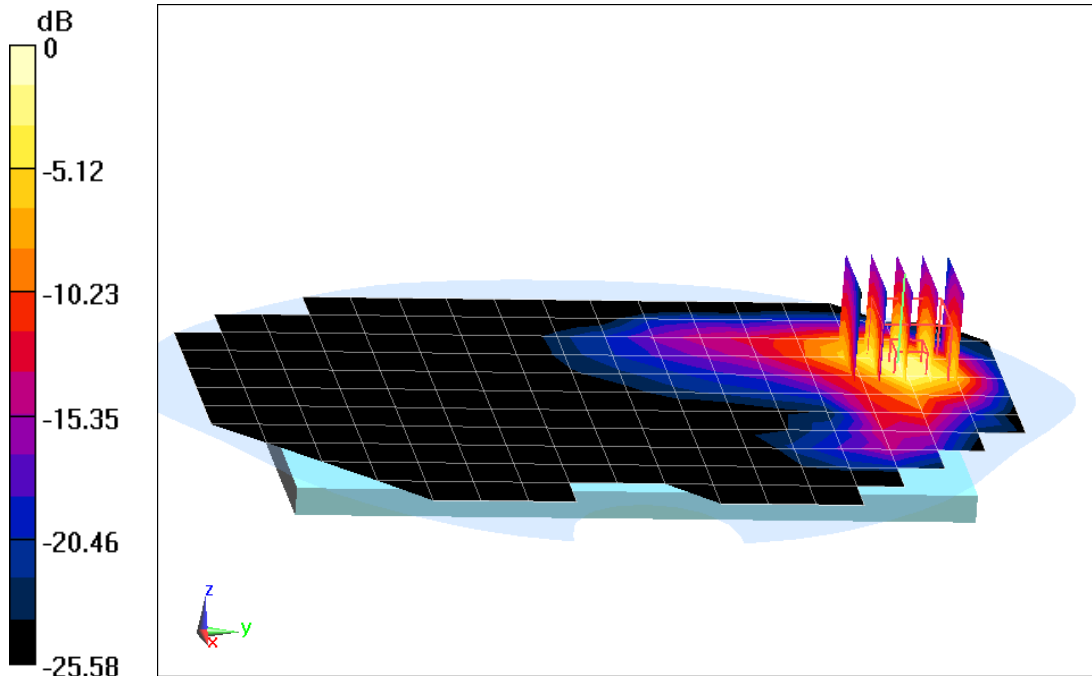

0 dB = 0.923 W/kg = -0.35 dBW/kg

PCTEST ENGINEERING LABORATORY, INC.

DUT: ZNFV495; Type: Portable Tablet; Serial: 1TRP8

Communication System: UID 0, LTE Band 12; Frequency: 707.5 MHz; Duty Cycle: 1:1
Medium: 750 Body Medium parameters used (interpolated):
 $f = 707.5 \text{ MHz}$; $\sigma = 0.934 \text{ S/m}$; $\epsilon_r = 55.349$; $\rho = 1000 \text{ kg/m}^3$
Phantom section: Flat Section; Space: 0.0 cm

Test Date: 03-24-2015; Ambient Temp: 23.8°C; Tissue Temp: 22.3°C

Probe: ES3DV3 - SN3263; ConvF(6.19, 6.19, 6.19); Calibrated: 5/15/2014;
Sensor-Surface: 3mm (Mechanical Surface Detection)
Electronics: DAE4 Sn859; Calibrated: 5/14/2014
Phantom: SAM v5.0 Left; Type: QD000P40CD; Serial: TP: 1687
Measurement SW: DASYS2, Version 52.8 (8); SEMCAD X Version 14.6.10 (7331)

**Mode: LTE Band 12, Body SAR, Back side, Mid.ch,
10 MHz Bandwidth, QPSK, 25 RB, 12 RB Offset**

Area Scan (12x16x1): Measurement grid: $dx=15\text{mm}$, $dy=15\text{mm}$
Zoom Scan (5x5x7)/Cube 0: Measurement grid: $dx=8\text{mm}$, $dy=8\text{mm}$, $dz=5\text{mm}$
Reference Value = 28.56 V/m; Power Drift = -0.01 dB
Peak SAR (extrapolated) = 1.43 W/kg
SAR(1 g) = 0.718 W/kg

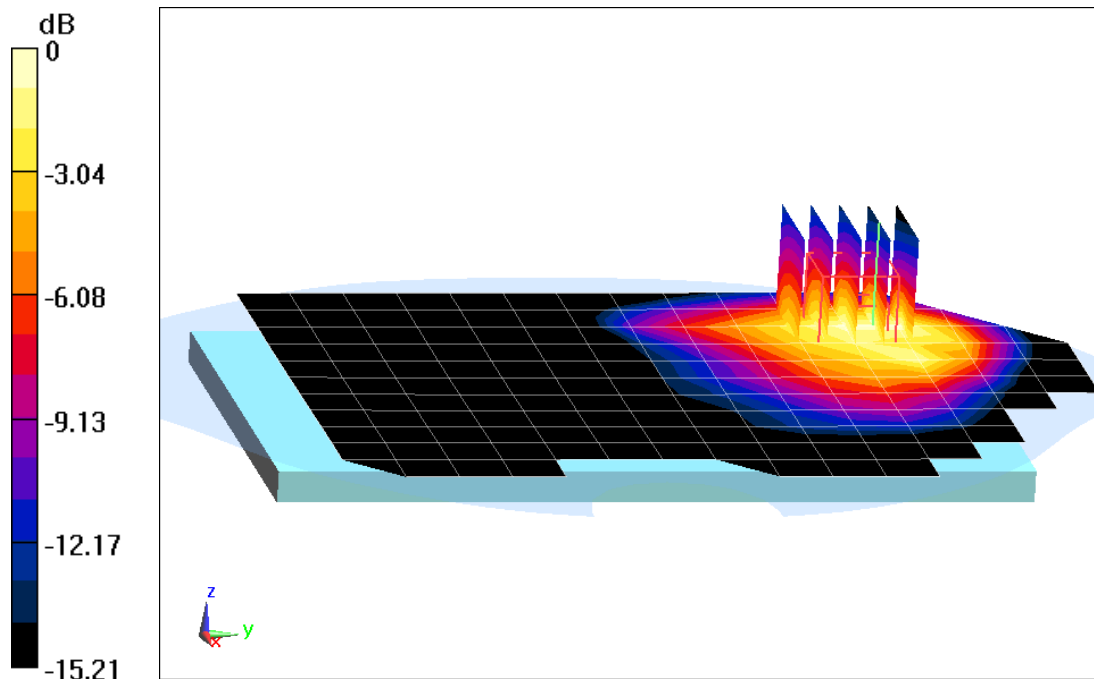

0 dB = 0.936 W/kg = -0.29 dBW/kg

PCTEST ENGINEERING LABORATORY, INC.

DUT: ZNFV495; Type: Portable Tablet; Serial: 1TRP8

Communication System: UID 0, LTE Band 5; Frequency: 836.5 MHz; Duty Cycle: 1:1
Medium: 835 Body Medium parameters used (interpolated):
 $f = 836.5 \text{ MHz}$; $\sigma = 1.019 \text{ S/m}$; $\epsilon_r = 54.002$; $\rho = 1000 \text{ kg/m}^3$
Phantom section: Flat Section; Space: 0.0 cm

Test Date: 03-16-2015; Ambient Temp: 24.7°C; Tissue Temp: 22.6°C

Probe: ES3DV3 - SN3288; ConvF(6.32, 6.32, 6.32); Calibrated: 9/24/2014;
Sensor-Surface: 3mm (Mechanical Surface Detection)
Electronics: DAE4 Sn1364; Calibrated: 9/18/2014
Phantom: ELI v5.0; Type: QDOVA001BB; Serial: 1229
Measurement SW: DASY52, Version 52.8 (8); SEMCAD X Version 14.6.10 (7331)

**Mode: LTE Band 5 (Cell.), Body SAR, Back side, Mid.ch,
10 MHz Bandwidth, QPSK, 25 RB, 25 RB Offset**

Area Scan (13x18x1): Measurement grid: dx=15mm, dy=15mm
Zoom Scan (5x5x7)/Cube 0: Measurement grid: dx=8mm, dy=8mm, dz=5mm
Reference Value = 25.16 V/m; Power Drift = 0.02 dB
Peak SAR (extrapolated) = 1.12 W/kg
SAR(1 g) = 0.544 W/kg

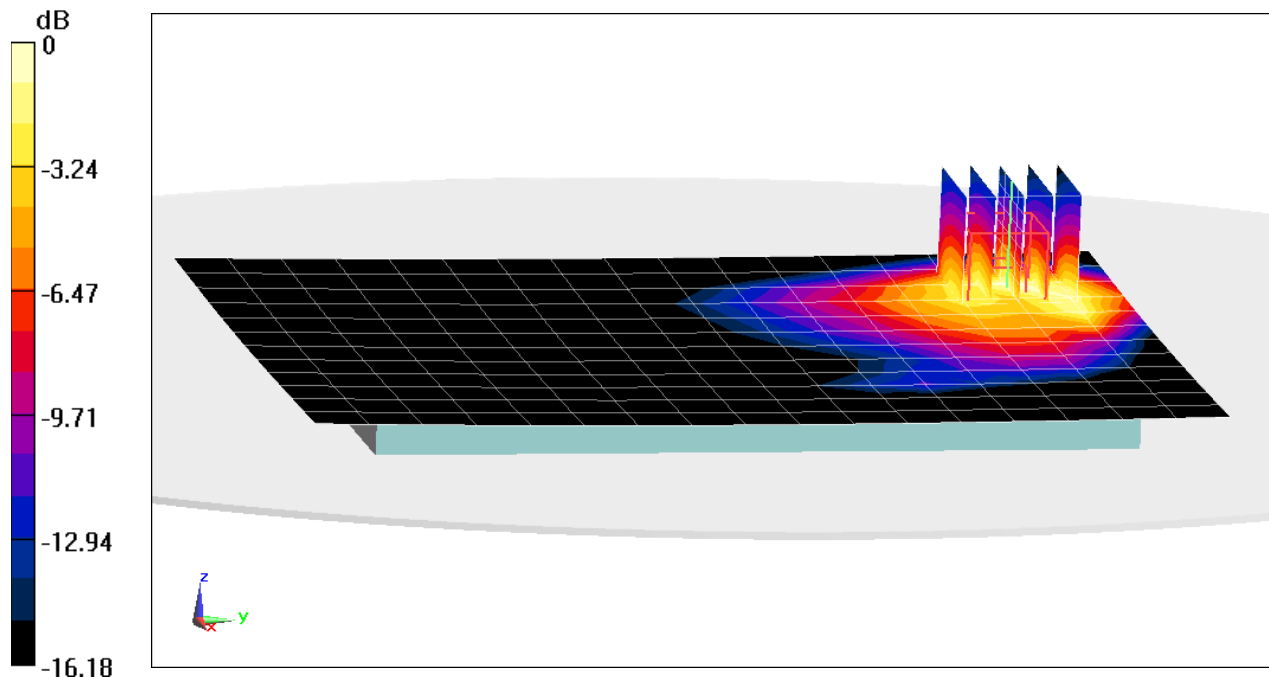

0 dB = 0.731 W/kg = -1.36 dBW/kg

PCTEST ENGINEERING LABORATORY, INC.

DUT: ZNFV495; Type: Portable Tablet; Serial: 1TRP8

Communication System: UID 0, LTE Band 4 (AWS); Frequency: 1732.5 MHz; Duty Cycle: 1:1
Medium: 1750 Body Medium parameters used (interpolated):
 $f = 1732.5 \text{ MHz}$; $\sigma = 1.457 \text{ S/m}$; $\epsilon_r = 52.227$; $\rho = 1000 \text{ kg/m}^3$
Phantom section: Flat Section; Space: 0.0 cm

Test Date: 03-23-2015; Ambient Temp: 22.4°C; Tissue Temp: 21.8°C

Probe: ES3DV3 - SN3332; ConvF(4.88, 4.88, 4.88); Calibrated: 9/18/2014;
Sensor-Surface: 3mm (Mechanical Surface Detection)
Electronics: DAE4 Sn1323; Calibrated: 9/17/2014
Phantom: SAM 5.0 front; Type: QD000P40CD; Serial: TP:-1648
Measurement SW: DASY52, Version 52.8 (8); SEMCAD X Version 14.6.10 (7331)

**Mode: LTE Band 4 (AWS), Body SAR, Back side, Mid.ch,
20 MHz Bandwidth, QPSK, 1 RB, 50 RB Offset**

Area Scan (12x19x1): Measurement grid: dx=15mm, dy=15mm
Zoom Scan (5x5x7)/Cube 0: Measurement grid: dx=8mm, dy=8mm, dz=5mm
Reference Value = 25.85 V/m; Power Drift = -0.03 dB
Peak SAR (extrapolated) = 1.55 W/kg
SAR(1 g) = 0.782 W/kg

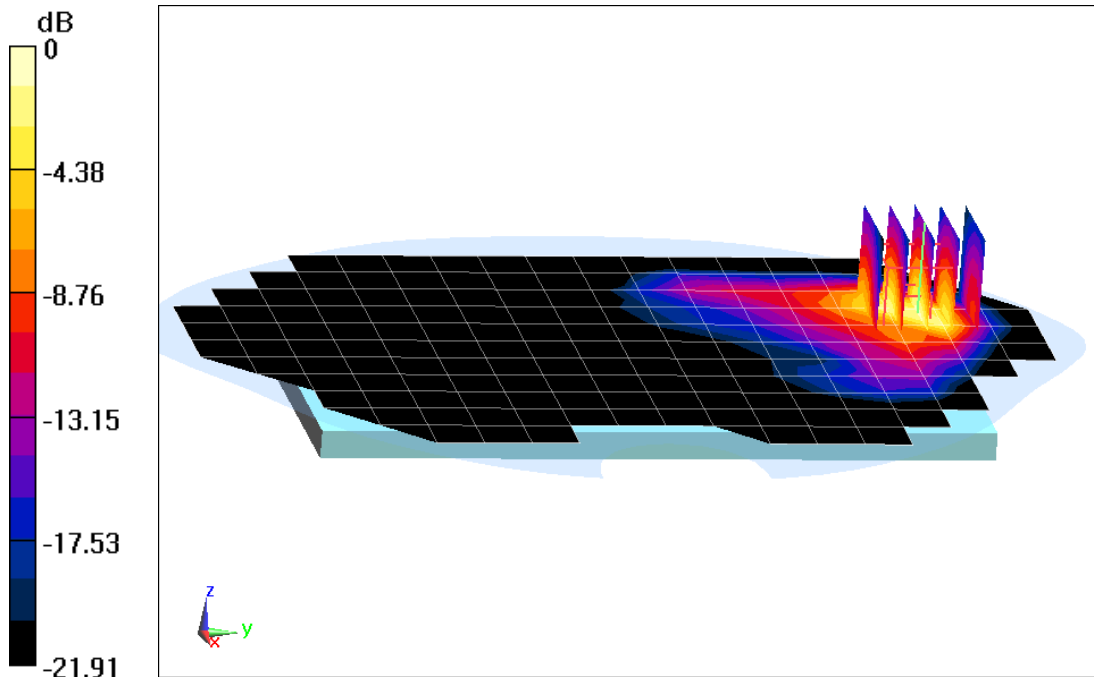

0 dB = 1.05 W/kg = 0.21 dBW/kg

PCTEST ENGINEERING LABORATORY, INC.

DUT: ZNFV495; Type: Portable Tablet; Serial: 1TRP8

Communication System: UID 0, LTE Band 2 (PCS); Frequency: 1880 MHz; Duty Cycle: 1:1

Medium: 1900 Body Medium parameters used:

$f = 1880 \text{ MHz}$; $\sigma = 1.548 \text{ S/m}$; $\epsilon_r = 51.527$; $\rho = 1000 \text{ kg/m}^3$

Phantom section: Flat Section; Space: 0.0 cm

Test Date: 03-17-2015; Ambient Temp: 23.7°C; Tissue Temp: 23.0°C

Probe: ES3DV3 - SN3263; ConvF(4.78, 4.78, 4.78); Calibrated: 5/15/2014;

Sensor-Surface: 3mm (Mechanical Surface Detection)

Electronics: DAE4 Sn859; Calibrated: 5/14/2014

Phantom: SAM v5.0 front; Type: QD000P40CD; Serial: TP-1646

Measurement SW: DASY52, Version 52.8 (8); SEMCAD X Version 14.6.10 (7331)

**Mode: LTE Band 2 (PCS), Body SAR, Back side, Mid.ch,
20 MHz Bandwidth, QPSK, 50 RB, 25 RB Offset**

Area Scan (13x18x1): Measurement grid: dx=15mm, dy=15mm

Zoom Scan (5x5x7)/Cube 0: Measurement grid: dx=8mm, dy=8mm, dz=5mm

Reference Value = 21.75 V/m; Power Drift = 0.00 dB

Peak SAR (extrapolated) = 1.34 W/kg

SAR(1 g) = 0.657 W/kg

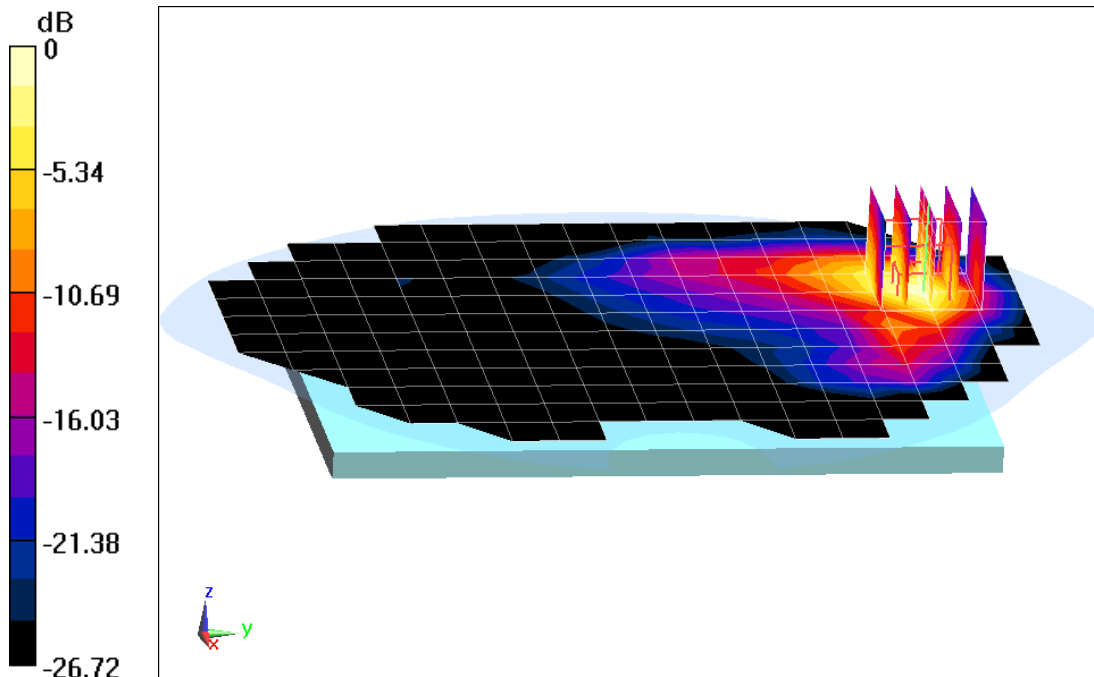

0 dB = 0.824 W/kg = -0.84 dBW/kg

PCTEST ENGINEERING LABORATORY, INC.

DUT: ZNFV495; Type: Portable Tablet; Serial: 1TRP7

Communication System: UID 0, LTE Band 7; Frequency: 2510 MHz; Duty Cycle: 1:1

Medium: 2450 Body Medium parameters used (interpolated):

$f = 2510 \text{ MHz}$; $\sigma = 2.118 \text{ S/m}$; $\epsilon_r = 50.857$; $\rho = 1000 \text{ kg/m}^3$

Phantom section: Flat Section; Space: 0.7 cm

Test Date: 03-25-2015; Ambient Temp: 24.0°C; Tissue Temp: 21.2°C

Probe: ES3DV3 - SN3213; ConvF(4.37, 4.37, 4.37); Calibrated: 1/20/2015;

Sensor-Surface: 3mm (Mechanical Surface Detection)

Electronics: DAE4 Sn1407; Calibrated: 1/19/2015

Phantom: ELI v6.0; Type: QDOVA003AA; Serial: TP:2027

Measurement SW: DASY52, Version 52.8 (8); SEMCAD X Version 14.6.10 (7331)

**Mode: LTE Band 7, Body SAR, Right Edge, Low ch,
20 MHz Bandwidth, QPSK, 1 RB, 0 RB Offset**

Area Scan (11x21x1): Measurement grid: dx=5mm, dy=12mm

Zoom Scan (7x7x7)/Cube 0: Measurement grid: dx=5mm, dy=5mm, dz=5mm

Reference Value = 23.89 V/m; Power Drift = 0.02 dB

Peak SAR (extrapolated) = 2.46 W/kg

SAR(1 g) = 1.17 W/kg

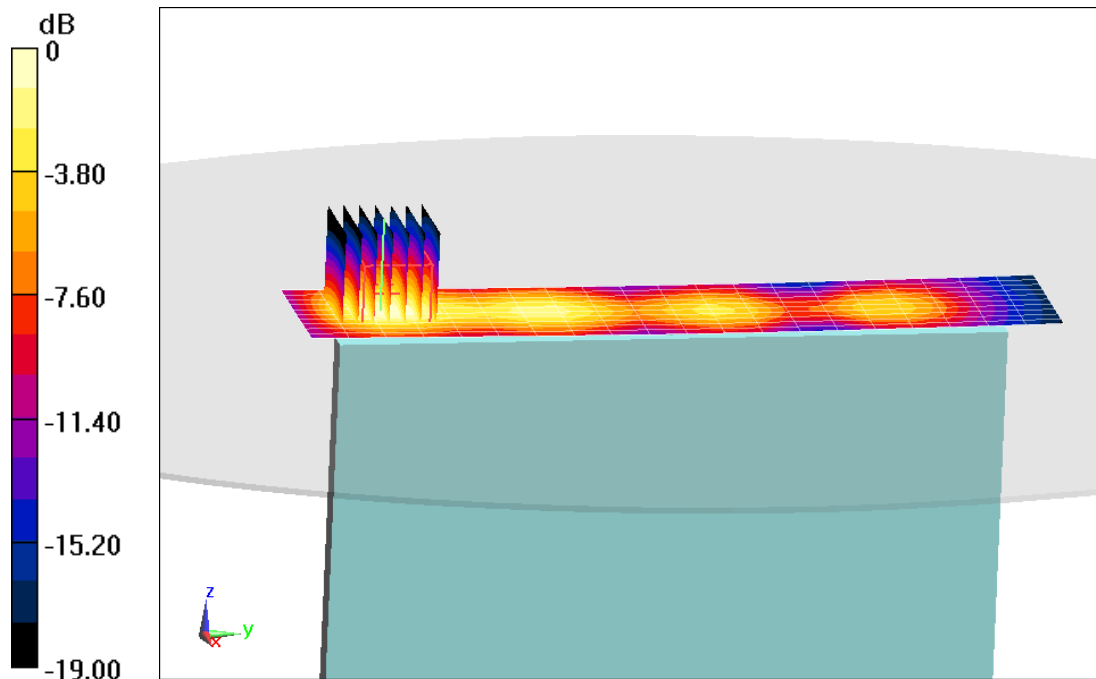

0 dB = 1.49 W/kg = 1.73 dBW/kg

PCTEST ENGINEERING LABORATORY, INC.

DUT: ZNFV495; Type: Portable Tablet; Serial: 1TRNY

Communication System: UID 0, IEEE 802.11b; Frequency: 2437 MHz; Duty Cycle: 1:1
Medium: 2450 Body Medium parameters used (interpolated):
 $f = 2437 \text{ MHz}$; $\sigma = 2.009 \text{ S/m}$; $\epsilon_r = 50.848$; $\rho = 1000 \text{ kg/m}^3$
Phantom section: Flat Section; Space; 0.0 cm

Test Date: 03-17-2015; Ambient Temp: 24.3°C; Tissue Temp: 22.4°C

Probe: ES3DV3 - SN3213; ConvF(4.37, 4.37, 4.37); Calibrated: 1/20/2015;
Sensor-Surface: 3mm (Mechanical Surface Detection)
Electronics: DAE4 Sn1407; Calibrated: 1/19/2015
Phantom: SAM Front; Type: SAM; Serial: 1686
Measurement SW: DASY52, Version 52.8 (8); SEMCAD X Version 14.6.10 (7331)

Mode: IEEE 802.11b, Body SAR, Ch 06, 1 Mbps, Back Side

Area Scan (16x21x1): Measurement grid: dx=12mm, dy=12mm
Zoom Scan (7x7x7)/Cube 0: Measurement grid: dx=5mm, dy=5mm, dz=5mm
Reference Value = 13.24 V/m; Power Drift = -0.05 dB
Peak SAR (extrapolated) = 1.10 W/kg
SAR(1 g) = 0.377 W/kg

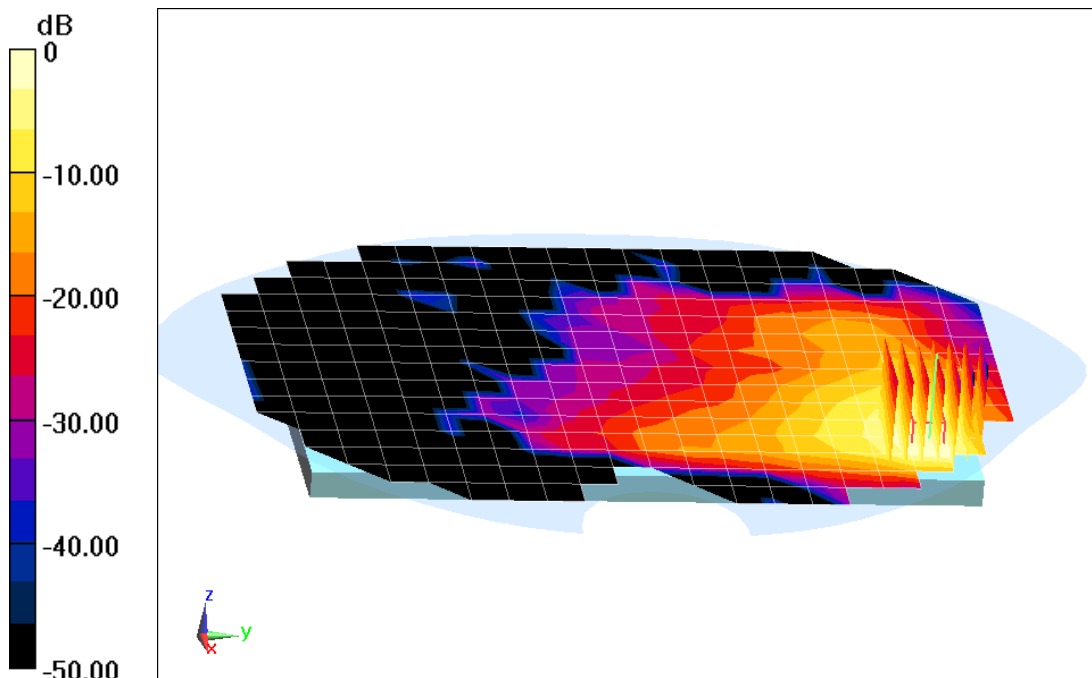

0 dB = 0.502 W/kg = -2.99 dBW/kg

PCTEST ENGINEERING LABORATORY, INC.

DUT: ZNFV495; Type: Portable Tablet; Serial: 1TRNW

Communication System: UID 0, IEEE 802.11a; Frequency: 5300 MHz; Duty Cycle: 1:1

Medium: 5GHz Body Medium parameters used:

$f = 5300 \text{ MHz}$; $\sigma = 5.286 \text{ S/m}$; $\epsilon_r = 47.366$; $\rho = 1000 \text{ kg/m}^3$

Phantom section: Flat Section; Space: 0.0 cm

Test Date: 03-17-2015; Ambient Temp: 23.3°C; Tissue Temp: 23.0°C

Probe: EX3DV4 - SN3914; ConvF(4.33, 4.33, 4.33); Calibrated: 2/10/2015;

Sensor-Surface: 1.4mm (Mechanical Surface Detection)

Electronics: DAE4 Sn1333; Calibrated: 10/31/2014

Phantom: SAM Sub ; Type: QD000P40CC; Serial: TP:1357

Measurement SW: DASY52, Version 52.8 (8); SEMCAD X Version 14.6.10 (7331)

Mode: IEEE 802.11a, 5.3 GHz, Body SAR, Ch 60, 6 Mbps, Back Side

Area Scan (7x7x1): Measurement grid: dx=10mm, dy=10mm

Zoom Scan (7x7x7)/Cube 0: Measurement grid: dx=4mm, dy=4mm, dz=1.4mm; Graded Ratio: 1.4

Reference Value = 9.264 V/m; Power Drift = -0.03 dB

Peak SAR (extrapolated) = 2.02 W/kg

SAR(1 g) = 0.425 W/kg

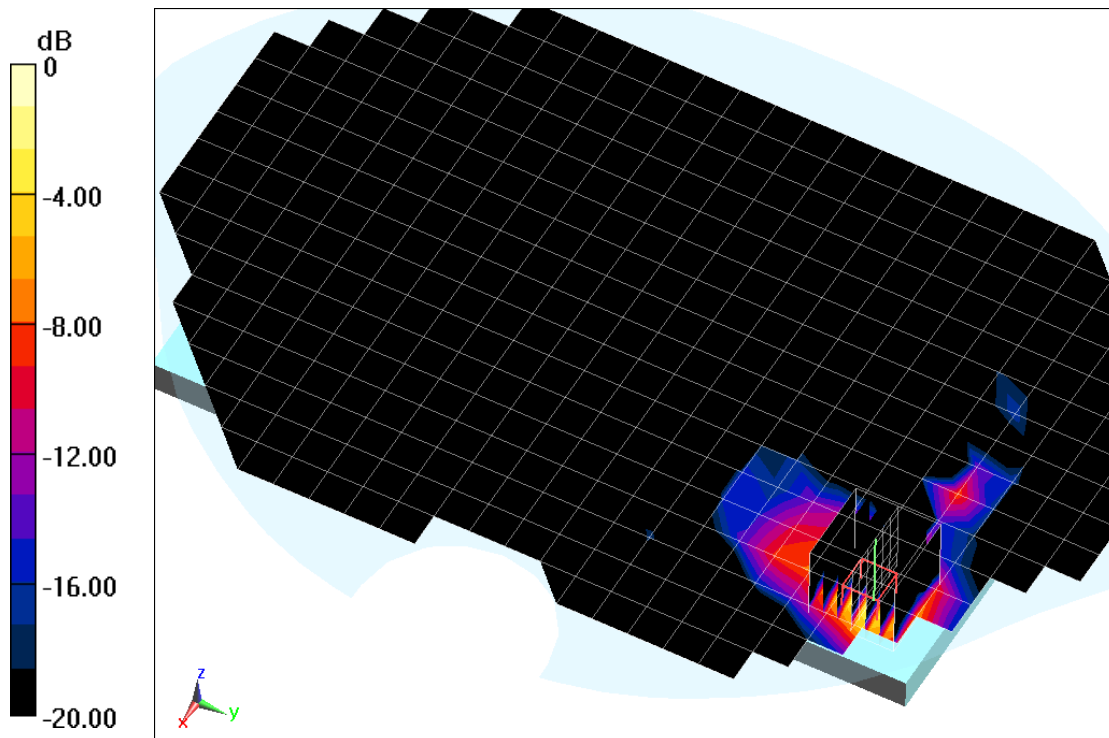

0 dB = 0.800 W/kg = -0.97 dBW/kg

PCTEST ENGINEERING LABORATORY, INC.

DUT: ZNFV495; Type: Portable Tablet; Serial: 1TRNY

Communication System: UID 0, Bluetooth; Frequency: 2441 MHz; Duty Cycle: 1:1
Medium: 2450 Body Medium parameters used (interpolated):
 $f = 2441$ MHz; $\sigma = 2.015$ S/m; $\epsilon_r = 50.833$; $\rho = 1000$ kg/m³
Phantom section: Flat Section; Space: 0.0 cm

Test Date: 03-17-2015; Ambient Temp: 24.3°C; Tissue Temp: 22.4°C

Probe: ES3DV3 - SN3213; ConvF(4.37, 4.37, 4.37); Calibrated: 1/20/2015;
Sensor-Surface: 3mm (Mechanical Surface Detection)
Electronics: DAE4 Sn1407; Calibrated: 1/19/2015
Phantom: SAM Front; Type: SAM; Serial: 1686
Measurement SW: DASY52, Version 52.8 (8); SEMCAD X Version 14.6.10 (7331)

Mode: Bluetooth, Body SAR, Ch 39, 1 Mbps, Back Side

Area Scan (16x21x1): Measurement grid: dx=12mm, dy=12mm
Zoom Scan (8x7x7)/Cube 0: Measurement grid: dx=5mm, dy=5mm, dz=5mm
Reference Value = 3.629 V/m; Power Drift = 0.02 dB
Peak SAR (extrapolated) = 0.0860 W/kg
SAR(1 g) = 0.031 W/kg

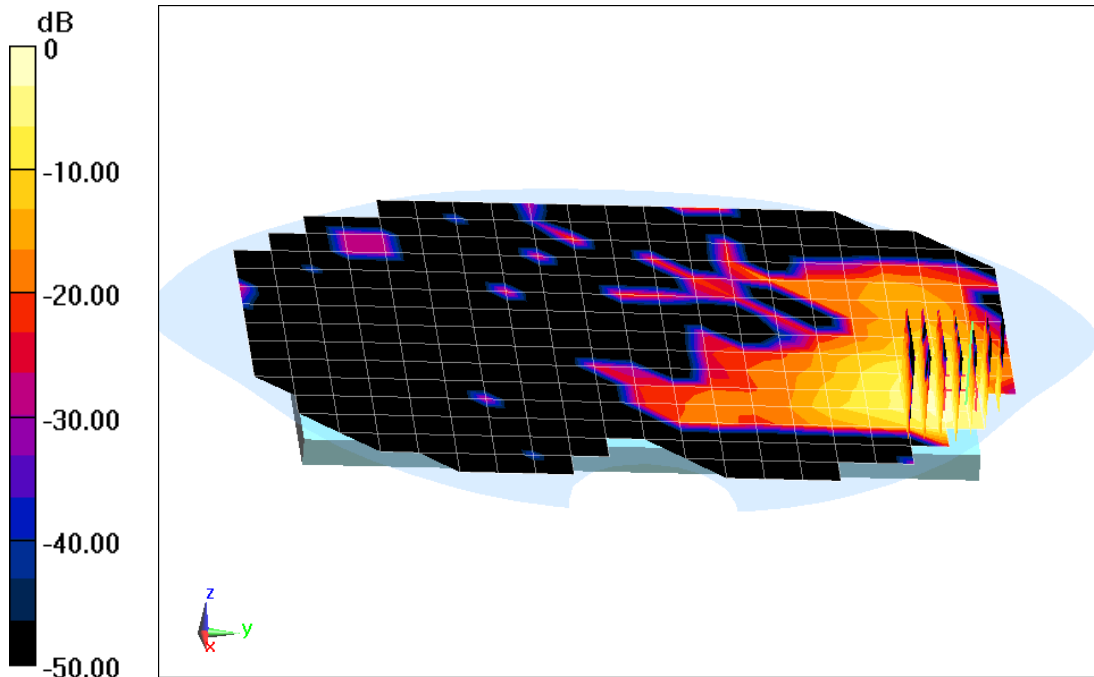

APPENDIX B: SYSTEM VERIFICATION

PCTEST ENGINEERING LABORATORY, INC.

DUT: Dipole 750 MHz; Type: D750V3; Serial: 1003

Communication System: UID 0, CW; Frequency: 750 MHz; Duty Cycle: 1:1

Medium: 750 Body Medium parameters used (interpolated):

$f = 750 \text{ MHz}$; $\sigma = 0.973 \text{ S/m}$; $\epsilon_r = 54.927$; $\rho = 1000 \text{ kg/m}^3$

Phantom section: Flat Section; Space: 1.5 cm

Test Date: 03-24-2015; Ambient Temp: 23.8°C; Tissue Temp: 22.3°C

Probe: ES3DV3 - SN3263; ConvF(6.19, 6.19, 6.19); Calibrated: 5/15/2014;

Sensor-Surface: 3mm (Mechanical Surface Detection)

Electronics: DAE4 Sn859; Calibrated: 5/14/2014

Phantom: SAM v5.0 Left; Type: QD000P40CD; Serial: TP: 1687

Measurement SW: DASY52, Version 52.8 (8); SEMCAD X Version 14.6.10 (7331)

750 MHz System Verification

Area Scan (7x15x1): Measurement grid: dx=15mm, dy=15mm

Zoom Scan (5x5x7)/Cube 0: Measurement grid: dx=8mm, dy=8mm, dz=5mm

Input Power = 20.0 dBm (100mW)

Peak SAR (extrapolated) = 1.35 W/kg

SAR(1 g) = 0.916 W/kg

Deviation = 8.27%

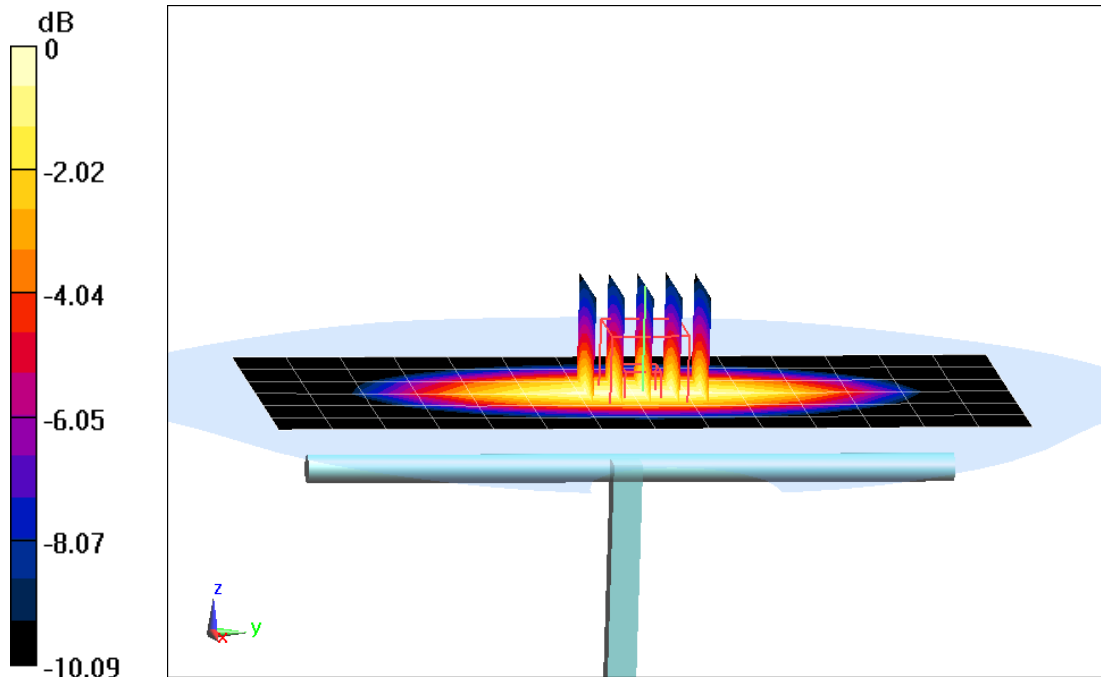

0 dB = 1.06 W/kg = 0.25 dBW/kg

PCTEST ENGINEERING LABORATORY, INC.

DUT: Dipole 835 MHz; Type: D835V2; Serial: 4d133

Communication System: UID 0, CW; Frequency: 835 MHz; Duty Cycle: 1:1

Medium: 835 Body Medium parameters used:

$f = 835 \text{ MHz}$; $\sigma = 1.018 \text{ S/m}$; $\epsilon_r = 54.016$; $\rho = 1000 \text{ kg/m}^3$

Phantom section: Flat Section; Space: 1.5 cm

Test Date: 03-16-2015; Ambient Temp: 24.7°C; Tissue Temp: 22.6°C

Probe: ES3DV3 - SN3288; ConvF(6.32, 6.32, 6.32); Calibrated: 9/24/2014;

Sensor-Surface: 3mm (Mechanical Surface Detection)

Electronics: DAE4 Sn1364; Calibrated: 9/18/2014

Phantom: ELI v5.0; Type: QDOVA001BB; Serial: 1229

Measurement SW: DASY52, Version 52.8 (8); SEMCAD X Version 14.6.10 (7331)

835 MHz System Verification

Area Scan (7x14x1): Measurement grid: dx=15mm, dy=15mm

Zoom Scan (5x5x7)/Cube 0: Measurement grid: dx=8mm, dy=8mm, dz=5mm

Input Power = 20.0 dBm (100mW)

Peak SAR (extrapolated) = 1.47 W/kg

SAR(1 g) = 0.999 W/kg

Deviation = 6.84%

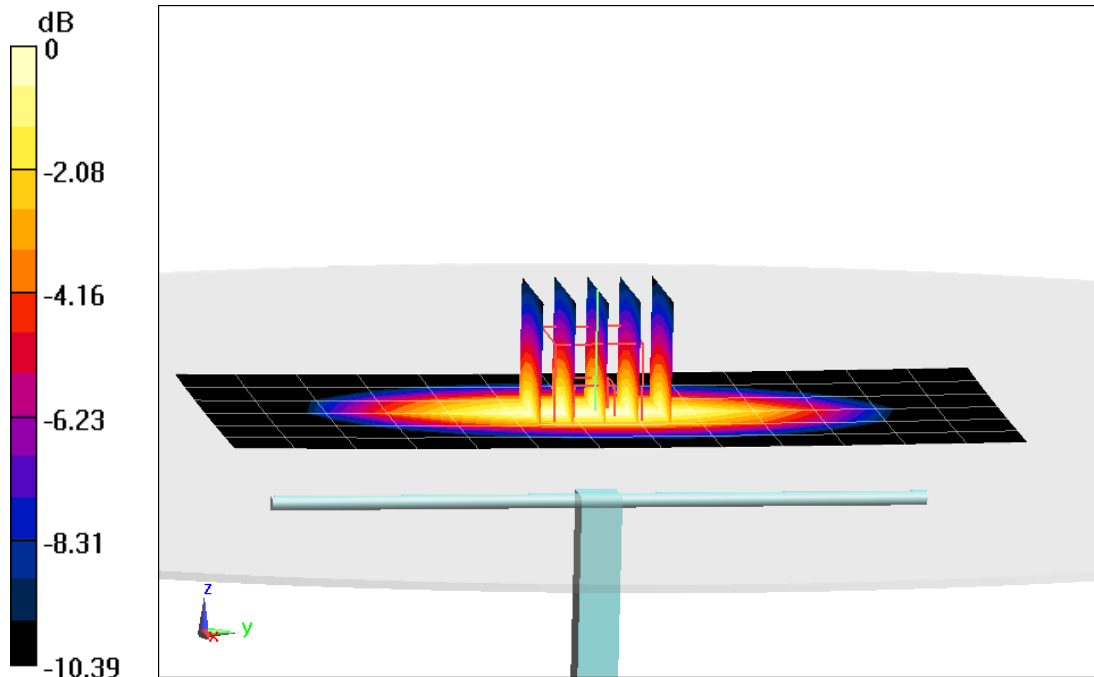

PCTEST ENGINEERING LABORATORY, INC.

DUT: Dipole 835 MHz; Type: D835V2; Serial: 4d119

Communication System: UID 0, CW; Frequency: 835 MHz; Duty Cycle: 1:1

Medium: 835 Body Medium parameters used:

$f = 835 \text{ MHz}$; $\sigma = 1.01 \text{ S/m}$; $\epsilon_r = 54.531$; $\rho = 1000 \text{ kg/m}^3$

Phantom section: Flat Section; Space: 1.5 cm

Test Date: 03-18-2015; Ambient Temp: 22.8°C; Tissue Temp: 22.5°C

Probe: ES3DV3 - SN3288; ConvF(6.32, 6.32, 6.32); Calibrated: 9/24/2014;

Sensor-Surface: 3mm (Mechanical Surface Detection)

Electronics: DAE4 Sn1364; Calibrated: 9/18/2014

Phantom: ELI v5.0; Type: QDOVA001BB; Serial: 1229

Measurement SW: DASY52, Version 52.8 (8); SEMCAD X Version 14.6.10 (7331)

835 MHz System Verification

Area Scan (7x14x1): Measurement grid: dx=15mm, dy=15mm

Zoom Scan (5x5x7)/Cube 0: Measurement grid: dx=8mm, dy=8mm, dz=5mm

Input Power = 20.0 dBm (100mW)

Peak SAR (extrapolated) = 1.49 W/kg

SAR(1 g) = 1.01 W/kg

Deviation = 8.14%

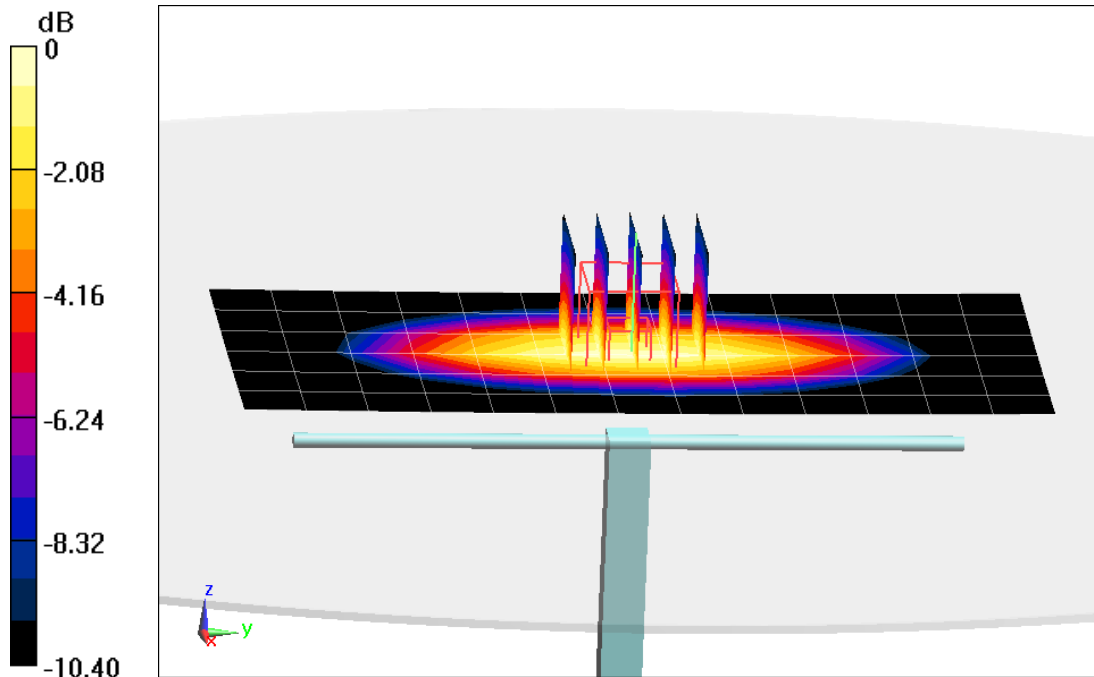

0 dB = 1.18 W/kg = 0.72 dBW/kg

PCTEST ENGINEERING LABORATORY, INC.

DUT: Dipole 1765 MHz; Type: D1765V2; Serial: 1008

Communication System: UID 0, CW; Frequency: 1750 MHz; Duty Cycle: 1:1

Medium: 1750 Body Medium parameters used:

$f = 1750 \text{ MHz}$; $\sigma = 1.477 \text{ S/m}$; $\epsilon_r = 52.15$; $\rho = 1000 \text{ kg/m}^3$

Phantom section: Flat Section; Space: 1.0 cm

Test Date: 03-23-2015; Ambient Temp: 22.4°C; Tissue Temp: 21.8°C

Probe: ES3DV3 - SN3332; ConvF(4.88, 4.88, 4.88); Calibrated: 9/18/2014;

Sensor-Surface: 3mm (Mechanical Surface Detection)

Electronics: DAE4 Sn1323; Calibrated: 9/17/2014

Phantom: SAM 5.0 front; Type: QD000P40CD; Serial: TP:-1648

Measurement SW: DASY52, Version 52.8 (8); SEMCAD X Version 14.6.10 (7331)

1750 MHz System Verification

Area Scan (7x9x1): Measurement grid: dx=15mm, dy=15mm

Zoom Scan (5x5x7)/Cube 0: Measurement grid: dx=8mm, dy=8mm, dz=5mm

Input Power = 20.0 dBm (100mW)

Peak SAR (extrapolated) = 6.16 W/kg

SAR(1 g) = 3.52 W/kg

Deviation = -6.38%

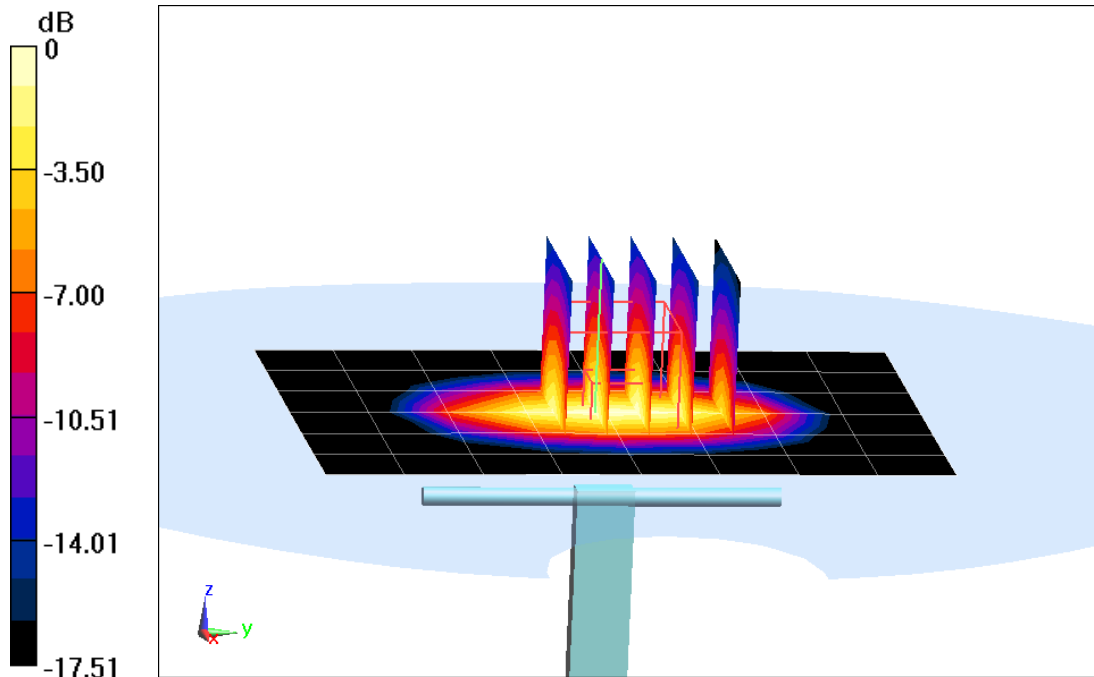

PCTEST ENGINEERING LABORATORY, INC.

DUT: Dipole 1900 MHz; Type: D1900V2; Serial: 5d149

Communication System: UID 0, CW; Frequency: 1900 MHz; Duty Cycle: 1:1

Medium: 1900 Body Medium parameters used (interpolated):

$f = 1900$ MHz; $\sigma = 1.571$ S/m; $\epsilon_r = 51.448$; $\rho = 1000$ kg/m³

Phantom section: Flat Section; Space: 1.0 cm

Test Date: 03-17-2015; Ambient Temp: 23.7°C; Tissue Temp: 23.0°C

Probe: ES3DV3 - SN3263; ConvF(4.78, 4.78, 4.78); Calibrated: 5/15/2014;

Sensor-Surface: 3mm (Mechanical Surface Detection)

Electronics: DAE4 Sn859; Calibrated: 5/14/2014

Phantom: SAM v5.0 front; Type: QD000P40CD; Serial: TP-1646

Measurement SW: DASY52, Version 52.8 (8); SEMCAD X Version 14.6.10 (7331)

1900 MHz System Verification

Area Scan (7x10x1): Measurement grid: dx=15mm, dy=15mm

Zoom Scan (5x5x7)/Cube 0: Measurement grid: dx=8mm, dy=8mm, dz=5mm

Input Power = 20.0 dBm (100mW)

Peak SAR (extrapolated) = 7.17 W/kg

SAR(1 g) = 3.99 W/kg

Deviation = -1.24%

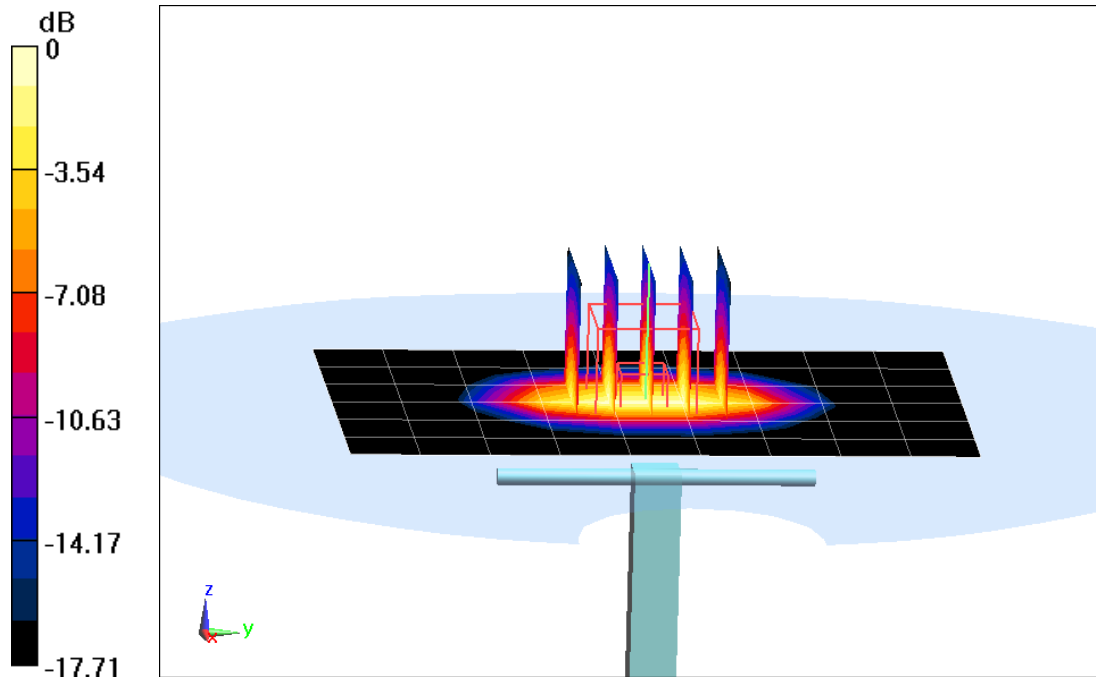

0 dB = 5.06 W/kg = 7.04 dBW/kg

PCTEST ENGINEERING LABORATORY, INC.

DUT: Dipole 2450 MHz; Type: D2450V2; Serial: 719

Communication System: UID 0, CW; Frequency: 2450 MHz; Duty Cycle: 1:1

Medium: 2450 Body Medium parameters used:

$f = 2450 \text{ MHz}$; $\sigma = 2.028 \text{ S/m}$; $\epsilon_r = 50.797$; $\rho = 1000 \text{ kg/m}^3$

Phantom section: Flat Section; Space: 1.0 cm

Test Date: 03-17-2015; Ambient Temp: 24.3°C; Tissue Temp: 22.4°C

Probe: ES3DV3 - SN3213; ConvF(4.37, 4.37, 4.37); Calibrated: 1/20/2015;

Sensor-Surface: 3mm (Mechanical Surface Detection)

Electronics: DAE4 Sn1407; Calibrated: 1/19/2015

Phantom: SAM Front; Type: SAM; Serial: 1686

Measurement SW: DASY52, Version 52.8 (8); SEMCAD X Version 14.6.10 (7331)

2450 MHz System Verification

Area Scan (8x9x1): Measurement grid: dx=12mm, dy=12mm

Zoom Scan (7x7x7)/Cube 0: Measurement grid: dx=5mm, dy=5mm, dz=5mm

Input Power = 20.0 dBm (100mW)

Peak SAR (extrapolated) = 11.5 W/kg

SAR(1 g) = 5.29 W/kg

Deviation = 2.12%

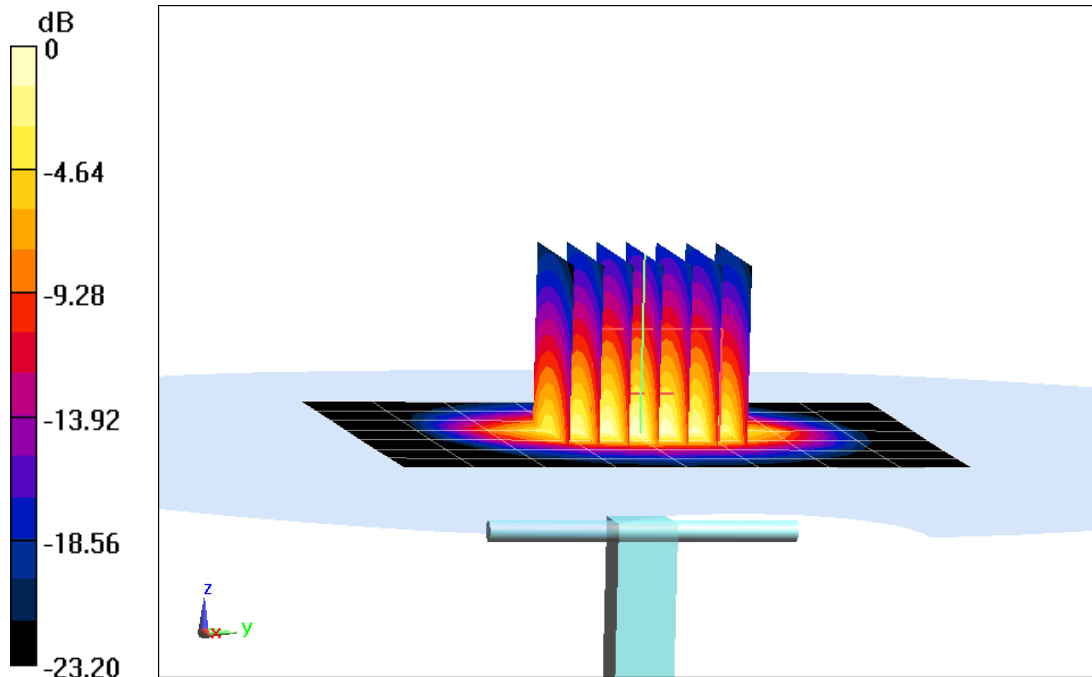

0 dB = 6.74 W/kg = 8.29 dBW/kg

PCTEST ENGINEERING LABORATORY, INC.

DUT: Dipole 2450 MHz; Type: D2450V2; Serial: 719

Communication System: UID 0, CW; Frequency: 2450 MHz; Duty Cycle: 1:1

Medium: 2450 Body Medium parameters used:

$f = 2450$ MHz; $\sigma = 2.041$ S/m; $\epsilon_r = 51.077$; $\rho = 1000$ kg/m³

Phantom section: Flat Section; Space: 1.0 cm

Test Date: 03-25-2015; Ambient Temp: 24.0°C; Tissue Temp: 21.2°C

Probe: ES3DV3 - SN3213; ConvF(4.37, 4.37, 4.37); Calibrated: 1/20/2015;

Sensor-Surface: 3mm (Mechanical Surface Detection)

Electronics: DAE4 Sn1407; Calibrated: 1/19/2015

Phantom: ELI v6.0; Type: QDOVA003AA; Serial: TP:2027

Measurement SW: DASY52, Version 52.8 (8); SEMCAD X Version 14.6.10 (7331)

2450 MHz System Verification

Area Scan (8x9x1): Measurement grid: dx=12mm, dy=12mm

Zoom Scan (7x7x7)/Cube 0: Measurement grid: dx=5mm, dy=5mm, dz=5mm

Input Power = 20.0 dBm (100mW)

Peak SAR (extrapolated) = 11.8 W/kg

SAR(1 g) = 5.51 W/kg

Deviation = 6.37%

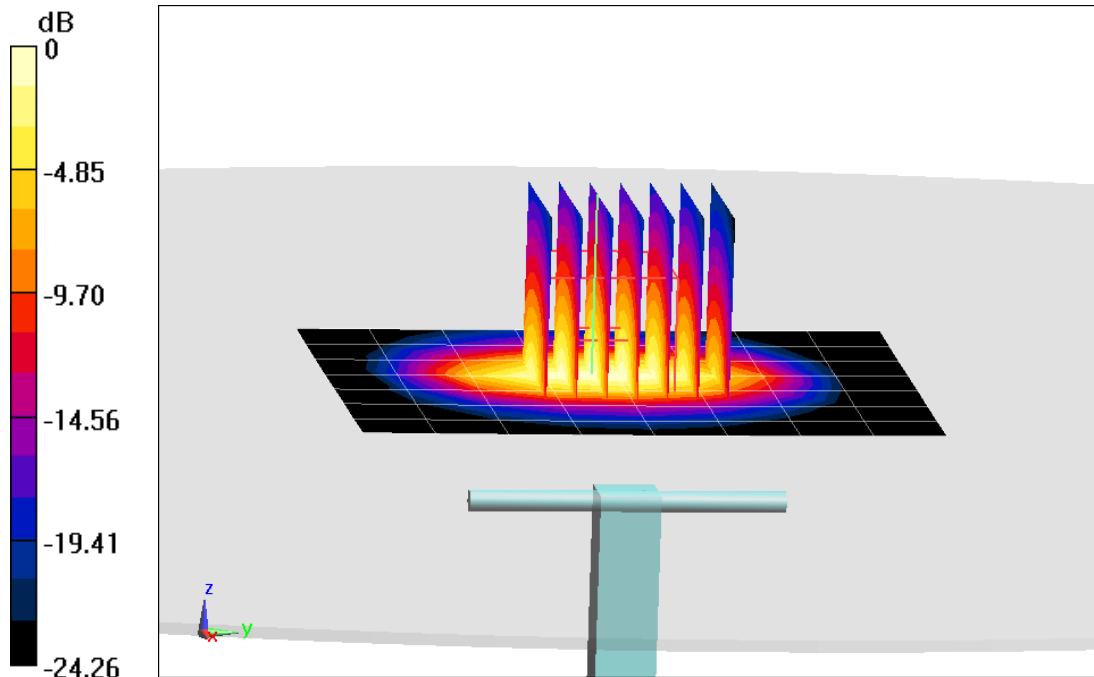

0 dB = 7.23 W/kg = 8.59 dBW/kg

PCTEST ENGINEERING LABORATORY, INC.

DUT: Dipole 2600 MHz; Type: D2600V2; Serial: 1071

Communication System: UID 0, CW (0); Frequency: 2600 MHz; Duty Cycle: 1:1

Medium: 2600 Body Medium parameters used:

$f = 2600 \text{ MHz}$; $\sigma = 2.247 \text{ S/m}$; $\epsilon_r = 50.52$; $\rho = 1000 \text{ kg/m}^3$

Phantom section: Flat Section; Space: 1.0 cm

Test Date: 03-25-2015; Ambient Temp: 24.0°C; Tissue Temp: 21.2°C

Probe: ES3DV3 - SN3213; ConvF(4.2, 4.2, 4.2); Calibrated: 1/20/2015;

Sensor-Surface: 3mm (Mechanical Surface Detection)

Electronics: DAE4 Sn1407; Calibrated: 1/19/2015

Phantom: ELI v6.0; Type: QDOVA003AA; Serial: TP:2027

Measurement SW: DASY52, Version 52.8 (8); SEMCAD X Version 14.6.10 (7331)

2600 MHz System Verification

Area Scan (8x9x1): Measurement grid: dx=12mm, dy=12mm

Zoom Scan (7x7x7)/Cube 0: Measurement grid: dx=5mm, dy=5mm, dz=5mm

Input Power = 20.0 dBm (100mW)

Peak SAR (extrapolated) = 14.2 W/kg

SAR(1 g) = 6.1 W/kg

Deviation = 7.21%

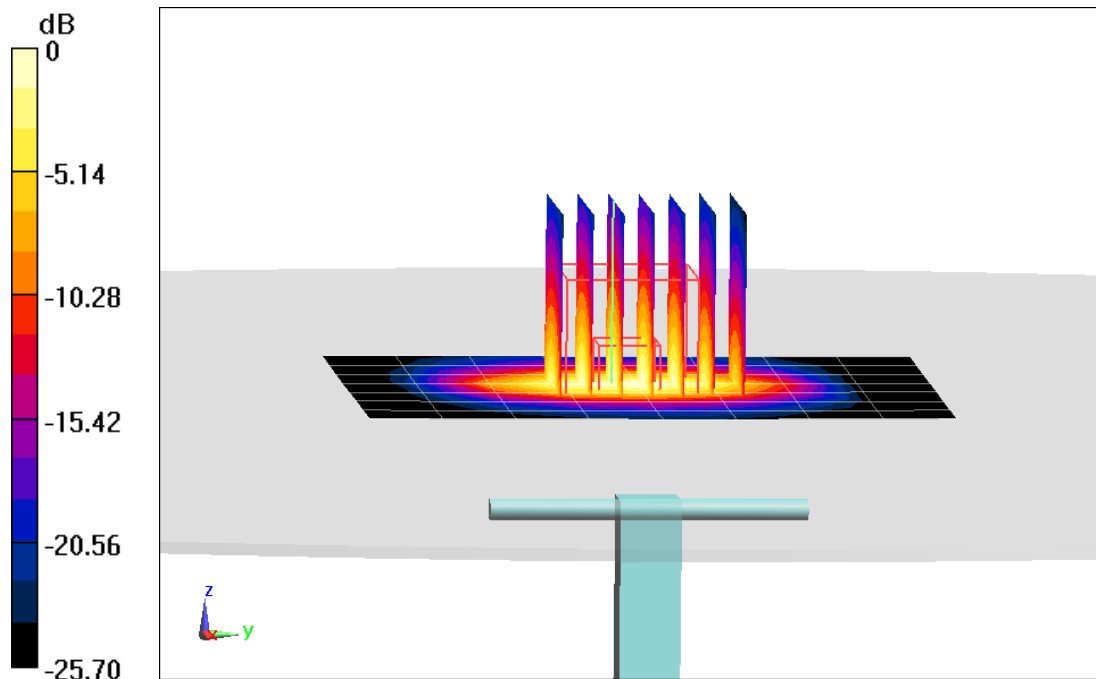

0 dB = 7.78 W/kg = 8.91 dBW/kg

PCTEST ENGINEERING LABORATORY, INC.

DUT: Dipole 5200 MHz; Type: D5GHzV2; Serial: 1191

Communication System: UID 0, CW; Frequency: 5200 MHz; Duty Cycle: 1:1

Medium: 5GHz Body Medium parameters used:

$f = 5200 \text{ MHz}$; $\sigma = 5.152 \text{ S/m}$; $\epsilon_r = 47.539$; $\rho = 1000 \text{ kg/m}^3$

Phantom section: Flat Section; Space: 1.0 cm

Test Date: 03-17-2015; Ambient Temp: 23.1°C; Tissue Temp: 23.0°C

Probe: EX3DV4 - SN3914; ConvF(4.5, 4.5, 4.5); Calibrated: 2/10/2015;

Sensor-Surface: 1.4mm (Mechanical Surface Detection)

Electronics: DAE4 Sn1333; Calibrated: 10/31/2014

Phantom: SAM Sub ; Type: QD000P40CC; Serial: TP:1357

Measurement SW: DASY52, Version 52.8 (8); SEMCAD X Version 14.6.10 (7331)

5200 MHz System Verification

Area Scan (7x7x1): Measurement grid: dx=10mm, dy=10mm

Zoom Scan (8x8x7)/Cube 0: Measurement grid: dx=4mm, dy=4mm, dz=1.4mm; Graded Ratio: 1.4

Input Power = 17.0 dBm (50 mW)

Peak SAR (extrapolated) = 15.7 W/kg

SAR(1 g) = 3.88 W/kg

Deviation = -0.26%

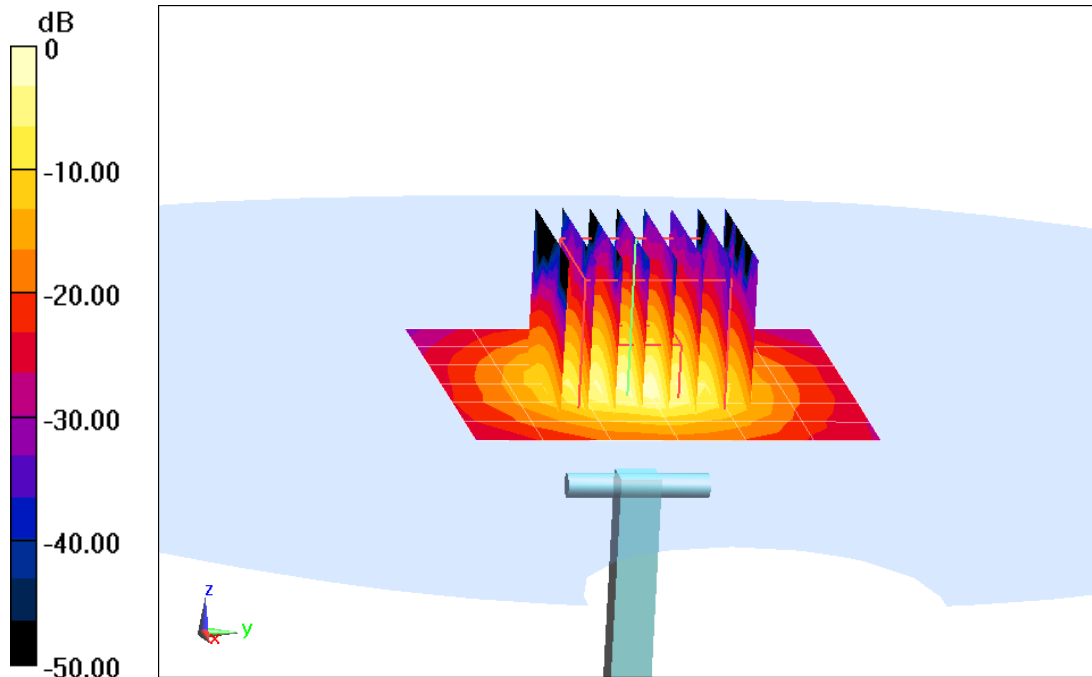

0 dB = 8.93 W/kg = 9.51 dBW/kg

PCTEST ENGINEERING LABORATORY, INC.

DUT: Dipole 5300 MHz; Type: D5GHzV2; Serial: 1191

Communication System: UID 0, CW; Frequency: 5300 MHz; Duty Cycle: 1:1

Medium: 5GHz Body Medium parameters used:

$f = 5300 \text{ MHz}$; $\sigma = 5.286 \text{ S/m}$; $\epsilon_r = 47.366$; $\rho = 1000 \text{ kg/m}^3$

Phantom section: Flat Section; Space: 1.0 cm

Test Date: 03-17-2015; Ambient Temp: 23.3°C; Tissue Temp: 23.0°C

Probe: EX3DV4 - SN3914; ConvF(4.33, 4.33, 4.33); Calibrated: 2/10/2015;

Sensor-Surface: 1.4mm (Mechanical Surface Detection)

Electronics: DAE4 Sn1333; Calibrated: 10/31/2014

Phantom: SAM Sub ; Type: QD000P40CC; Serial: TP:1357

Measurement SW: DASY52, Version 52.8 (8); SEMCAD X Version 14.6.10 (7331)

5300 MHz System Verification

Area Scan (7x8x1): Measurement grid: dx=10mm, dy=10mm

Zoom Scan (8x8x7)/Cube 0: Measurement grid: dx=4mm, dy=4mm, dz=1.4mm; Graded Ratio: 1.4

Input Power = 17.0 dBm (50 mW)

Peak SAR (extrapolated) = 16.5 W/kg

SAR(1 g) = 3.89 W/kg

Deviation = -2.63%

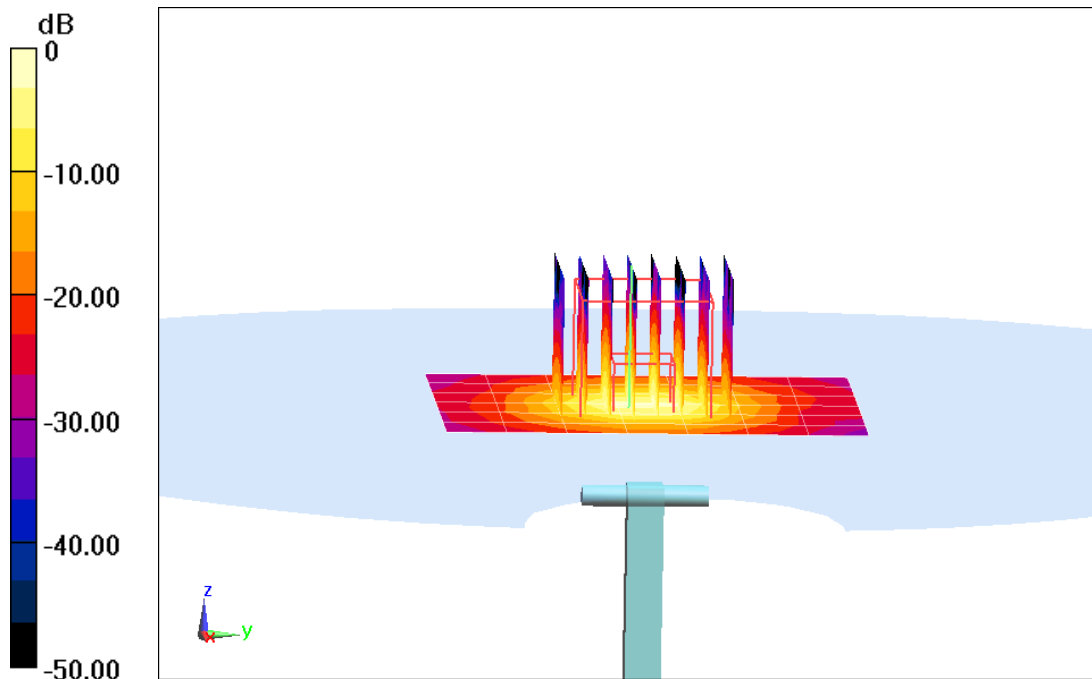

0 dB = 9.27 W/kg = 9.67 dBW/kg

PCTEST ENGINEERING LABORATORY, INC.

DUT: Dipole 5500 MHz; Type: D5GHzV2; Serial: 1191

Communication System: UID 0, CW; Frequency: 5500 MHz; Duty Cycle: 1:1

Medium: 5GHz Body Medium parameters used:

$f = 5500 \text{ MHz}$; $\sigma = 5.558 \text{ S/m}$; $\epsilon_r = 47.192$; $\rho = 1000 \text{ kg/m}^3$

Phantom section: Flat Section; Space: 1.0 cm

Test Date: 03-17-2015; Ambient Temp: 23.4°C; Tissue Temp: 22.9°C

Probe: EX3DV4 - SN3914; ConvF(3.91, 3.91, 3.91); Calibrated: 2/10/2015;

Sensor-Surface: 1.4mm (Mechanical Surface Detection)

Electronics: DAE4 Sn1333; Calibrated: 10/31/2014

Phantom: SAM Sub ; Type: QD000P40CC; Serial: TP:1357

Measurement SW: DASY52, Version 52.8 (8); SEMCAD X Version 14.6.10 (7331)

5500 MHz System Verification

Area Scan (7x7x1): Measurement grid: dx=10mm, dy=10mm

Zoom Scan (8x8x7)/Cube 0: Measurement grid: dx=4mm, dy=4mm, dz=1.4mm; Graded Ratio: 1.4

Input Power = 17.0 dBm (50 mW)

Peak SAR (extrapolated) = 17.2 W/kg

SAR(1 g) = 4.03 W/kg

Deviation = -3.01%

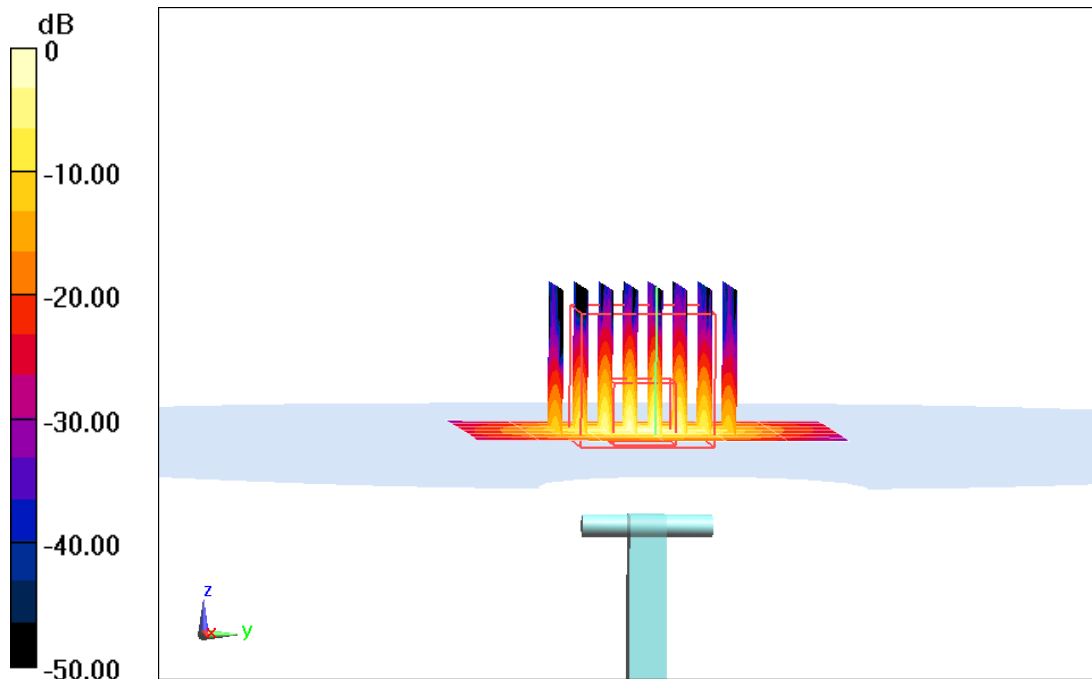

0 dB = 9.68 W/kg = 9.86 dBW/kg

PCTEST ENGINEERING LABORATORY, INC.

DUT: Dipole 5600 MHz; Type: D5GHzV2; Serial: 1191

Communication System: UID 0, CW; Frequency: 5600 MHz; Duty Cycle: 1:1

Medium: 5GHz Body Medium parameters used:

$f = 5600 \text{ MHz}$; $\sigma = 5.692 \text{ S/m}$; $\epsilon_r = 47.066$; $\rho = 1000 \text{ kg/m}^3$

Phantom section: Flat Section; Space: 1.0 cm

Test Date: 03-17-2015; Ambient Temp: 23.4°C; Tissue Temp: 23.0°C

Probe: EX3DV4 - SN3914; ConvF(3.89, 3.89, 3.89); Calibrated: 2/10/2015;

Sensor-Surface: 1.4mm (Mechanical Surface Detection)

Electronics: DAE4 Sn1333; Calibrated: 10/31/2014

Phantom: SAM Sub ; Type: QD000P40CC; Serial: TP:1357

Measurement SW: DASY52, Version 52.8 (8); SEMCAD X Version 14.6.10 (7331)

5600 MHz System Verification

Area Scan (7x7x1): Measurement grid: dx=10mm, dy=10mm

Zoom Scan (8x8x7)/Cube 0: Measurement grid: dx=4mm, dy=4mm, dz=1.4mm; Graded Ratio: 1.4

Input Power = 17.0 dBm (50 mW)

Peak SAR (extrapolated) = 17.4 W/kg

SAR(1 g) = 3.95 W/kg

Deviation = -6.06%

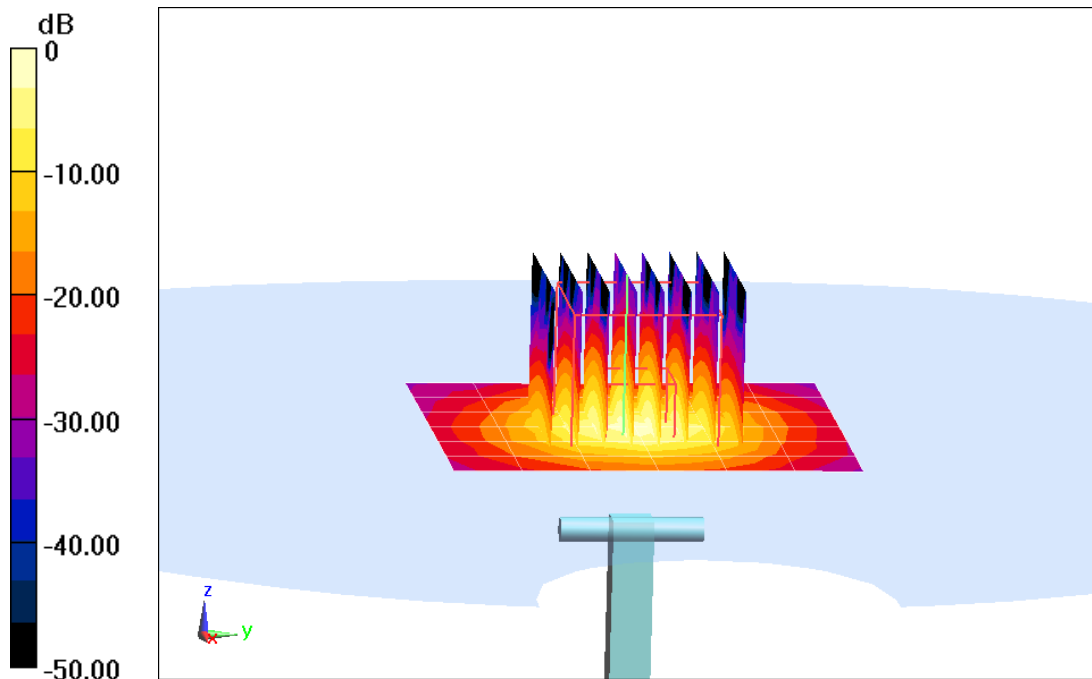

0 dB = 9.85 W/kg = 9.93 dBW/kg

PCTEST ENGINEERING LABORATORY, INC.

DUT: Dipole 5800 MHz; Type: D5GHzV2; Serial: 1191

Communication System: UID 0, CW; Frequency: 5800 MHz; Duty Cycle: 1:1

Medium: 5GHz Body Medium parameters used:

$f = 5800 \text{ MHz}$; $\sigma = 5.941 \text{ S/m}$; $\epsilon_r = 46.766$; $\rho = 1000 \text{ kg/m}^3$

Phantom section: Flat Section; Space: 1.0 cm

Test Date: 03-17-2015; Ambient Temp: 23.2°C; Tissue Temp: 23.0°C

Probe: EX3DV4 - SN3914; ConvF(4.01, 4.01, 4.01); Calibrated: 2/10/2015;

Sensor-Surface: 1.4mm (Mechanical Surface Detection)

Electronics: DAE4 Sn1333; Calibrated: 10/31/2014

Phantom: SAM Sub ; Type: QD000P40CC; Serial: TP:1357

Measurement SW: DASY52, Version 52.8 (8); SEMCAD X Version 14.6.10 (7331)

5800 MHz System Verification

Area Scan (7x7x1): Measurement grid: dx=10mm, dy=10mm

Zoom Scan (8x8x7)/Cube 0: Measurement grid: dx=4mm, dy=4mm, dz=1.4mm; Graded Ratio: 1.4

Input Power = 17.0 dBm (50 mW)

Peak SAR (extrapolated) = 16.4 W/kg

SAR(1 g) = 3.66 W/kg

Deviation = -6.15%

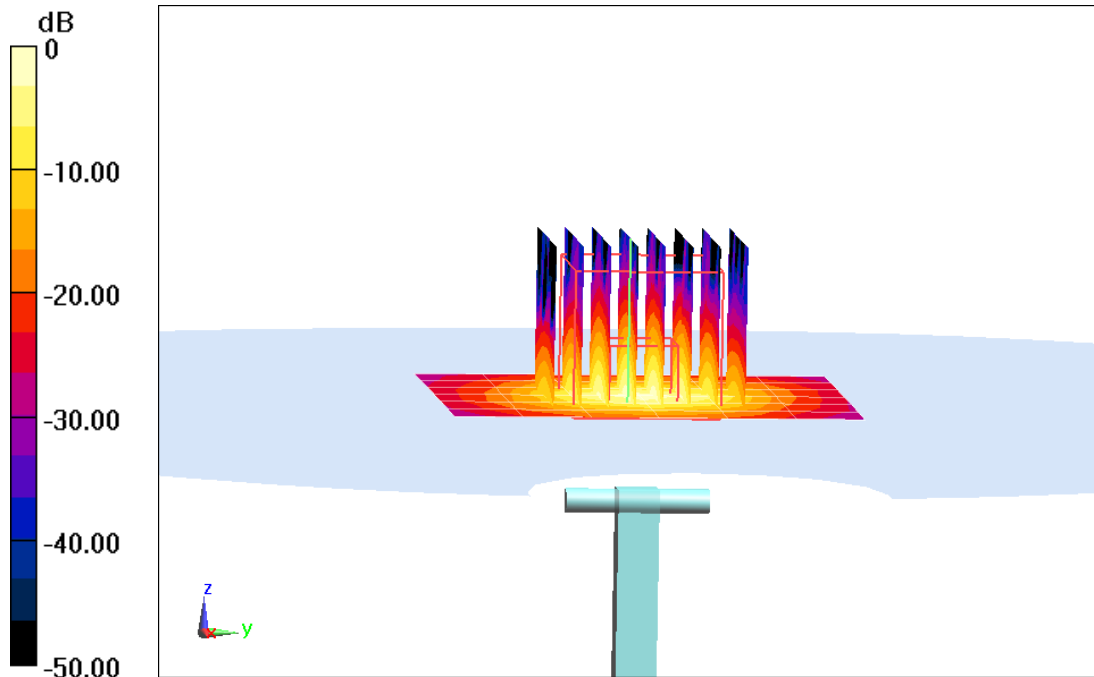

0 dB = 8.94 W/kg = 9.51 dBW/kg

APPENDIX C: PROBE CALIBRATION



Accredited by the Swiss Accreditation Service (SAS)
The Swiss Accreditation Service is one of the signatories to the EA
Multilateral Agreement for the recognition of calibration certificates

Accreditation No.: **SCS 108**

Client **PC Test**

Certificate No: **ES3-3263_May14**

CALIBRATION CERTIFICATE

Object **ES3DV3 - SN:3263**

Calibration procedure(s) **QA CAL-01.v9, QA CAL-23.v5, QA CAL-25.v6
Calibration procedure for dosimetric E-field probes**

OCV
7/17/14

Calibration date: **May 15, 2014**

This calibration certificate documents the traceability to national standards, which realize the physical units of measurements (SI).
The measurements and the uncertainties with confidence probability are given on the following pages and are part of the certificate.

All calibrations have been conducted in the closed laboratory facility: environment temperature (22 ± 3)°C and humidity < 70%.

Calibration Equipment used (M&TE critical for calibration)

Primary Standards	ID	Cal Date (Certificate No.)	Scheduled Calibration
Power meter E4419B	GB41293874	03-Apr-14 (No. 217-01911)	Apr-15
Power sensor E4412A	MY41498087	03-Apr-14 (No. 217-01911)	Apr-15
Reference 3 dB Attenuator	SN: S5054 (3c)	03-Apr-14 (No. 217-01915)	Apr-15
Reference 20 dB Attenuator	SN: S5277 (20x)	03-Apr-14 (No. 217-01919)	Apr-15
Reference 30 dB Attenuator	SN: S5129 (30b)	03-Apr-14 (No. 217-01920)	Apr-15
Reference Probe ES3DV2	SN: 3013	30-Dec-13 (No. ES3-3013_Dec13)	Dec-14
DAE4	SN: 660	13-Dec-13 (No. DAE4-660_Dec13)	Dec-14
Secondary Standards	ID	Check Date (in house)	Scheduled Check
RF generator HP 8648C	US3642U01700	4-Aug-99 (in house check Apr-13)	In house check: Apr-16
Network Analyzer HP 8753E	US37390585	18-Oct-01 (in house check Oct-13)	In house check: Oct-14

	Name	Function	Signature
Calibrated by:	Jeton Kastrati	Laboratory Technician	
Approved by:	Katja Pokovic	Technical Manager	
			Issued: May 15, 2014

This calibration certificate shall not be reproduced except in full without written approval of the laboratory.



Accredited by the Swiss Accreditation Service (SAS)
The Swiss Accreditation Service is one of the signatories to the EA
Multilateral Agreement for the recognition of calibration certificates

Accreditation No.: **SCS 108**

Glossary:

TSL	tissue simulating liquid
NORM _{x,y,z}	sensitivity in free space
ConvF	sensitivity in TSL / NORM _{x,y,z}
DCP	diode compression point
CF	crest factor (1/duty_cycle) of the RF signal
A, B, C, D	modulation dependent linearization parameters
Polarization φ	φ rotation around probe axis
Polarization ϑ	ϑ rotation around an axis that is in the plane normal to probe axis (at measurement center), i.e., $\vartheta = 0$ is normal to probe axis
Connector Angle	information used in DASY system to align probe sensor X to the robot coordinate system

Calibration is Performed According to the Following Standards:

- IEEE Std 1528-2013, "IEEE Recommended Practice for Determining the Peak Spatial-Averaged Specific Absorption Rate (SAR) in the Human Head from Wireless Communications Devices: Measurement Techniques", June 2013
- IEC 62209-1, "Procedure to measure the Specific Absorption Rate (SAR) for hand-held devices used in close proximity to the ear (frequency range of 300 MHz to 3 GHz)", February 2005

Methods Applied and Interpretation of Parameters:

- NORM_{x,y,z}**: Assessed for E-field polarization $\vartheta = 0$ ($f \leq 900$ MHz in TEM-cell; $f > 1800$ MHz: R22 waveguide). NORM_{x,y,z} are only intermediate values, i.e., the uncertainties of NORM_{x,y,z} does not affect the E²-field uncertainty inside TSL (see below *ConvF*).
- NORM(f)_{x,y,z}** = NORM_{x,y,z} * *frequency_response* (see Frequency Response Chart). This linearization is implemented in DASY4 software versions later than 4.2. The uncertainty of the frequency response is included in the stated uncertainty of *ConvF*.
- DCP_{x,y,z}**: DCP are numerical linearization parameters assessed based on the data of power sweep with CW signal (no uncertainty required). DCP does not depend on frequency nor media.
- PAR**: PAR is the Peak to Average Ratio that is not calibrated but determined based on the signal characteristics
- A_{x,y,z}; B_{x,y,z}; C_{x,y,z}; D_{x,y,z}; VR_{x,y,z}**: A, B, C, D are numerical linearization parameters assessed based on the data of power sweep for specific modulation signal. The parameters do not depend on frequency nor media. VR is the maximum calibration range expressed in RMS voltage across the diode.
- ConvF and Boundary Effect Parameters**: Assessed in flat phantom using E-field (or Temperature Transfer Standard for $f \leq 800$ MHz) and inside waveguide using analytical field distributions based on power measurements for $f > 800$ MHz. The same setups are used for assessment of the parameters applied for boundary compensation (alpha, depth) of which typical uncertainty values are given. These parameters are used in DASY4 software to improve probe accuracy close to the boundary. The sensitivity in TSL corresponds to NORM_{x,y,z} * *ConvF* whereby the uncertainty corresponds to that given for *ConvF*. A frequency dependent *ConvF* is used in DASY version 4.4 and higher which allows extending the validity from ± 50 MHz to ± 100 MHz.
- Spherical isotropy (3D deviation from isotropy)**: in a field of low gradients realized using a flat phantom exposed by a patch antenna.
- Sensor Offset**: The sensor offset corresponds to the offset of virtual measurement center from the probe tip (on probe axis). No tolerance required.
- Connector Angle**: The angle is assessed using the information gained by determining the NORM_x (no uncertainty required).

Probe ES3DV3

SN:3263

Manufactured: January 25, 2010
Calibrated: May 15, 2014

Calibrated for DASYS/EASY Systems
(Note: non-compatible with DASYS2 system!)

DASY/EASY - Parameters of Probe: ES3DV3 - SN:3263

Basic Calibration Parameters

	Sensor X	Sensor Y	Sensor Z	Unc (k=2)
Norm ($\mu\text{V}/(\text{V}/\text{m})^2$) ^A	1.21	1.24	1.13	$\pm 10.1\%$
DCP (mV) ^B	103.8	102.3	104.7	

Modulation Calibration Parameters

UID	Communication System Name		A dB	B dB $\sqrt{\mu\text{V}}$	C	D dB	VR mV	Unc ^E (k=2)
0	CW	X	0.0	0.0	1.0	0.00	156.3	$\pm 3.5\%$
		Y	0.0	0.0	1.0		203.1	
		Z	0.0	0.0	1.0		197.2	
10010- CAA	SAR Validation (Square, 100ms, 10ms)	X	2.33	59.4	10.8	10.00	46.4	$\pm 1.4\%$
		Y	4.39	63.4	13.6		50.8	
		Z	1.35	55.5	7.8		39.6	
10011- CAB	UMTS-FDD (WCDMA)	X	3.49	68.2	19.1	2.91	126.7	$\pm 0.7\%$
		Y	3.28	66.9	18.5		120.7	
		Z	2.74	63.1	15.1		113.5	
10012- CAA	IEEE 802.11b WiFi 2.4 GHz (DSSS, 1 Mbps)	X	3.51	72.0	20.3	1.87	127.9	$\pm 0.7\%$
		Y	3.21	69.4	18.8		124.1	
		Z	1.93	60.6	12.6		113.3	
10013- CAA	IEEE 802.11g WiFi 2.4 GHz (DSSS-OFDM, 6 Mbps)	X	11.30	70.8	23.3	9.46	125.2	$\pm 2.5\%$
		Y	12.42	72.7	24.4		129.4	
		Z	10.03	67.8	21.1		105.5	
10021- DAB	GSM-FDD (TDMA, GMSK)	X	24.45	99.1	27.6	9.39	141.4	$\pm 1.4\%$
		Y	29.93	99.5	29.0		124.5	
		Z	4.53	73.0	18.1		111.6	
10023- DAB	GPRS-FDD (TDMA, GMSK, TN 0)	X	25.10	99.7	27.9	9.57	134.2	$\pm 1.9\%$
		Y	24.85	96.1	28.0		120.2	
		Z	5.99	76.5	19.1		142.5	
10024- DAB	GPRS-FDD (TDMA, GMSK, TN 0-1)	X	24.34	93.0	23.0	6.56	117.1	$\pm 1.4\%$
		Y	26.49	92.6	24.2		148.7	
		Z	4.00	69.6	13.8		136.6	
10027- DAB	GPRS-FDD (TDMA, GMSK, TN 0-1-2)	X	51.24	99.9	23.5	4.80	131.1	$\pm 1.9\%$
		Y	56.83	99.5	24.3		101.8	
		Z	1.70	61.4	9.1		107.7	
10028- DAB	GPRS-FDD (TDMA, GMSK, TN 0-1-2-3)	X	60.12	99.6	22.2	3.55	138.7	$\pm 1.9\%$
		Y	64.73	99.9	23.4		105.5	
		Z	1.13	58.4	6.0		116.0	
10032- CAA	IEEE 802.15.1 Bluetooth (GFSK, DH5)	X	77.27	99.6	19.6	1.16	149.5	$\pm 2.5\%$
		Y	60.44	99.7	21.0		109.4	
		Z	0.34	55.9	2.9		131.4	
10039- CAB	CDMA2000 (1xRTT, RC1)	X	4.79	66.8	19.0	4.57	124.5	$\pm 0.9\%$
		Y	4.85	66.4	18.8		125.6	
		Z	4.06	63.4	16.1		108.1	

10081-CAB	CDMA2000 (1xRTT, RC3)	X	3.93	66.1	18.5	3.97	119.8	±0.7 %
		Y	3.90	65.5	18.2		120.1	
		Z	3.29	62.4	15.3		108.5	
10098-CAB	UMTS-FDD (HSUPA, Subtest 2)	X	4.68	66.9	18.7	3.98	131.2	±0.7 %
		Y	4.64	66.6	18.6		130.5	
		Z	4.15	64.5	16.5		118.8	
10100-CAB	LTE-FDD (SC-FDMA, 100% RB, 20 MHz, QPSK)	X	6.61	68.1	20.0	5.67	137.5	±1.7 %
		Y	6.70	68.4	20.2		137.7	
		Z	5.90	65.6	17.9		124.0	
10108-CAB	LTE-FDD (SC-FDMA, 100% RB, 10 MHz, QPSK)	X	6.44	67.5	19.8	5.80	135.1	±1.7 %
		Y	6.60	68.0	20.1		135.4	
		Z	5.75	64.9	17.6		121.8	
10110-CAB	LTE-FDD (SC-FDMA, 100% RB, 5 MHz, QPSK)	X	6.14	67.1	19.7	5.75	131.6	±1.2 %
		Y	6.28	67.4	19.9		132.7	
		Z	5.62	65.5	18.2		118.4	
10114-CAA	IEEE 802.11n (HT Greenfield, 13.5 Mbps, BPSK)	X	10.18	68.8	21.2	8.10	124.3	±1.9 %
		Y	10.60	69.7	21.8		126.2	
		Z	9.38	67.0	19.8		108.4	
10117-CAA	IEEE 802.11n (HT Mixed, 13.5 Mbps, BPSK)	X	10.23	68.9	21.3	8.07	125.0	±1.9 %
		Y	10.56	69.6	21.7		127.1	
		Z	9.37	67.1	19.8		109.1	
10151-CAB	LTE-TDD (SC-FDMA, 50% RB, 20 MHz, QPSK)	X	10.23	75.7	26.0	9.28	125.0	±2.7 %
		Y	14.60	83.3	29.5		147.3	
		Z	8.05	69.7	22.3		106.3	
10154-CAB	LTE-FDD (SC-FDMA, 50% RB, 10 MHz, QPSK)	X	6.12	67.0	19.6	5.75	131.6	±1.4 %
		Y	6.28	67.4	19.9		132.4	
		Z	5.49	64.7	17.4		117.9	
10160-CAB	LTE-FDD (SC-FDMA, 50% RB, 15 MHz, QPSK)	X	6.57	67.5	19.8	5.82	136.0	±1.4 %
		Y	6.71	67.9	20.1		137.1	
		Z	5.89	65.2	17.8		122.4	
10169-CAB	LTE-FDD (SC-FDMA, 1 RB, 20 MHz, QPSK)	X	4.82	66.0	19.3	5.73	113.5	±1.4 %
		Y	5.12	66.3	19.4		116.6	
		Z	4.75	65.9	18.3		142.7	
10172-CAB	LTE-TDD (SC-FDMA, 1 RB, 20 MHz, QPSK)	X	9.53	80.6	28.6	9.21	136.5	±2.2 %
		Y	11.32	81.6	28.8		109.2	
		Z	6.84	72.0	23.8		117.3	
10175-CAB	LTE-FDD (SC-FDMA, 1 RB, 10 MHz, QPSK)	X	4.86	66.2	19.4	5.72	112.9	±1.2 %
		Y	5.10	66.2	19.4		115.9	
		Z	4.55	64.9	17.8		137.7	
10181-CAB	LTE-FDD (SC-FDMA, 1 RB, 15 MHz, QPSK)	X	4.81	66.0	19.2	5.72	111.6	±1.2 %
		Y	5.13	66.4	19.5		116.1	
		Z	4.70	65.7	18.3		137.1	
10193-CAA	IEEE 802.11n (HT Greenfield, 6.5 Mbps, BPSK)	X	9.80	68.3	21.0	8.09	117.2	±2.2 %
		Y	10.23	69.1	21.6		121.5	
		Z	9.85	68.9	20.8		148.4	

10196-CAA	IEEE 802.11n (HT Mixed, 6.5 Mbps, BPSK)	X	9.81	68.4	21.1	8.10	117.7	±2.2 %
		Y	10.23	69.2	21.6		121.7	
		Z	9.87	69.0	20.9		149.9	
10219-CAA	IEEE 802.11n (HT Mixed, 7.2 Mbps, BPSK)	X	9.71	68.3	21.0	8.03	117.8	±2.2 %
		Y	10.12	69.1	21.6		121.0	
		Z	8.90	66.6	19.6		104.1	
10222-CAA	IEEE 802.11n (HT Mixed, 15 Mbps, BPSK)	X	10.14	68.7	21.2	8.06	122.3	±1.9 %
		Y	10.52	69.5	21.7		125.4	
		Z	9.28	66.8	19.6		108.5	
10225-CAB	UMTS-FDD (HSPA+)	X	7.25	67.8	19.9	5.97	146.3	±1.7 %
		Y	7.32	67.5	19.8		149.3	
		Z	6.52	65.7	18.0		130.7	
10237-CAB	LTE-TDD (SC-FDMA, 1 RB, 10 MHz, QPSK)	X	9.55	80.7	28.7	9.21	137.2	±2.5 %
		Y	11.34	81.7	28.9		109.9	
		Z	6.98	72.5	24.0		119.5	
10252-CAB	LTE-TDD (SC-FDMA, 50% RB, 10 MHz, QPSK)	X	9.26	74.1	25.3	9.24	115.6	±3.3 %
		Y	13.72	82.5	29.3		137.9	
		Z	8.83	73.3	24.4		144.1	
10267-CAB	LTE-TDD (SC-FDMA, 100% RB, 10 MHz, QPSK)	X	10.06	75.2	25.8	9.30	122.9	±2.7 %
		Y	14.69	83.4	29.6		147.6	
		Z	8.02	69.6	22.3		103.4	
10274-CAB	UMTS-FDD (HSUPA, Subtest 5, 3GPP Rel8.10)	X	6.08	67.2	19.0	4.87	140.2	±1.2 %
		Y	6.23	67.5	19.2		143.5	
		Z	5.52	65.4	17.4		125.1	
10275-CAB	UMTS-FDD (HSUPA, Subtest 5, 3GPP Rel8.4)	X	4.44	66.7	18.7	3.96	122.1	±0.7 %
		Y	4.39	66.3	18.5		124.4	
		Z	3.83	63.7	16.0		114.0	
10291-AAB	CDMA2000, RC3, SO55, Full Rate	X	3.64	66.7	18.6	3.46	115.7	±0.7 %
		Y	3.60	66.0	18.2		118.0	
		Z	3.17	64.2	16.3		108.4	
10292-AAB	CDMA2000, RC3, SO32, Full Rate	X	3.62	67.0	18.8	3.39	116.9	±0.9 %
		Y	3.54	66.1	18.2		119.1	
		Z	3.24	64.2	15.8		145.6	
10297-AAA	LTE-FDD (SC-FDMA, 50% RB, 20 MHz, QPSK)	X	6.43	67.5	19.8	5.81	132.0	±1.4 %
		Y	6.60	68.0	20.1		134.9	
		Z	5.81	65.4	18.0		115.0	
10311-AAA	LTE-FDD (SC-FDMA, 100% RB, 15 MHz, QPSK)	X	7.04	68.1	20.2	6.06	137.5	±1.4 %
		Y	7.19	68.6	20.5		140.3	
		Z	6.26	65.7	18.2		119.6	
10315-AAA	IEEE 802.11b WiFi 2.4 GHz (DSSS, 1 Mbps, 96pc duty cycle)	X	3.05	70.0	19.4	1.71	121.7	±0.7 %
		Y	2.91	68.7	18.7		123.4	
		Z	1.83	60.2	12.3		108.4	
10316-AAA	IEEE 802.11g WiFi 2.4 GHz (ERP-OFDM, 6 Mbps, 96pc duty cycle)	X	10.05	68.7	21.4	8.36	117.3	±1.9 %
		Y	10.57	69.7	22.0		122.8	
		Z	9.11	66.5	19.7		103.1	

10403-AAB	CDMA2000 (1xEV-DO, Rev. 0)	X	4.81	68.3	18.8	3.76	125.8	±0.7 %
		Y	4.65	66.5	18.1		130.8	
		Z	3.98	64.7	16.0		114.7	
10404-AAB	CDMA2000 (1xEV-DO, Rev. A)	X	4.91	69.1	19.2	3.77	123.3	±0.7 %
		Y	4.60	66.6	18.1		128.5	
		Z	3.73	64.0	15.4		112.0	
10415-AAA	IEEE 802.11b WiFi 2.4 GHz (DSSS, 1 Mbps, 99pc duty cycle)	X	2.78	69.0	19.0	1.54	121.9	±0.7 %
		Y	2.46	66.8	17.9		122.5	
		Z	1.83	60.9	13.0		112.4	
10416-AAA	IEEE 802.11g WiFi 2.4 GHz (ERP-OFDM, 6 Mbps, 99pc duty cycle)	X	9.88	68.4	21.2	8.23	116.6	±1.7 %
		Y	10.29	69.2	21.7		121.5	
		Z	9.25	67.3	20.2		103.4	

The reported uncertainty of measurement is stated as the standard uncertainty of measurement multiplied by the coverage factor $k=2$, which for a normal distribution corresponds to a coverage probability of approximately 95%.

^A The uncertainties of NormX,Y,Z do not affect the E^2 -field uncertainty inside TSL (see Pages 8 and 9).

^B Numerical linearization parameter: uncertainty not required.

^E Uncertainty is determined using the max. deviation from linear response applying rectangular distribution and is expressed for the square of the field value.

DASY/EASY - Parameters of Probe: ES3DV3 - SN:3263

Calibration Parameter Determined in Head Tissue Simulating Media

f (MHz) ^C	Relative Permittivity ^F	Conductivity (S/m) ^F	ConvF X	ConvF Y	ConvF Z	Alpha ^G	Depth ^G (mm)	Unct. (k=2)
750	41.9	0.89	6.42	6.42	6.42	0.72	1.18	± 12.0 %
835	41.5	0.90	6.23	6.23	6.23	0.27	2.02	± 12.0 %
1750	40.1	1.37	5.41	5.41	5.41	0.74	1.23	± 12.0 %
1900	40.0	1.40	5.08	5.08	5.08	0.80	1.16	± 12.0 %
2450	39.2	1.80	4.47	4.47	4.47	0.80	1.22	± 12.0 %
2600	39.0	1.96	4.33	4.33	4.33	0.66	1.41	± 12.0 %

^C Frequency validity of ± 100 MHz only applies for DASY v4.4 and higher (see Page 2), else it is restricted to ± 50 MHz. The uncertainty is the RSS of the ConvF uncertainty at calibration frequency and the uncertainty for the indicated frequency band.

^F At frequencies below 3 GHz, the validity of tissue parameters (ϵ and σ) can be relaxed to ± 10% if liquid compensation formula is applied to measured SAR values. At frequencies above 3 GHz, the validity of tissue parameters (ϵ and σ) is restricted to ± 5%. The uncertainty is the RSS of the ConvF uncertainty for indicated target tissue parameters.

^G Alpha/Depth are determined during calibration. SPEAG warrants that the remaining deviation due to the boundary effect after compensation is always less than ± 1% for frequencies below 3 GHz and below ± 2% for frequencies between 3-6 GHz at any distance larger than half the probe tip diameter from the boundary.

DASY/EASY - Parameters of Probe: ES3DV3 - SN:3263

Calibration Parameter Determined in Body Tissue Simulating Media

f (MHz) ^C	Relative Permittivity ^F	Conductivity (S/m) ^F	ConvF X	ConvF Y	ConvF Z	Alpha ^G	Depth (mm) ^G	Unct. (k=2)
750	55.5	0.96	6.19	6.19	6.19	0.52	1.41	± 12.0 %
835	55.2	0.97	6.16	6.16	6.16	0.68	1.28	± 12.0 %
1750	53.4	1.49	4.98	4.98	4.98	0.38	1.91	± 12.0 %
1900	53.3	1.52	4.78	4.78	4.78	0.66	1.35	± 12.0 %
2450	52.7	1.95	4.27	4.27	4.27	0.72	1.13	± 12.0 %
2600	52.5	2.16	4.11	4.11	4.11	0.74	1.07	± 12.0 %

^C Frequency validity of ± 100 MHz only applies for DASY v4.4 and higher (see Page 2), else it is restricted to ± 50 MHz. The uncertainty is the RSS of the ConvF uncertainty at calibration frequency and the uncertainty for the indicated frequency band.

^F At frequencies below 3 GHz, the validity of tissue parameters (ϵ and σ) can be relaxed to ± 10% if liquid compensation formula is applied to measured SAR values. At frequencies above 3 GHz, the validity of tissue parameters (ϵ and σ) is restricted to ± 5%. The uncertainty is the RSS of the ConvF uncertainty for indicated target tissue parameters.

^G Alpha/Depth are determined during calibration. SPEAG warrants that the remaining deviation due to the boundary effect after compensation is always less than ± 1% for frequencies below 3 GHz and below ± 2% for frequencies between 3-6 GHz at any distance larger than half the probe tip diameter from the boundary.

Frequency Response of E-Field (TEM-Cell:ifi110 EXX, Waveguide: R22)

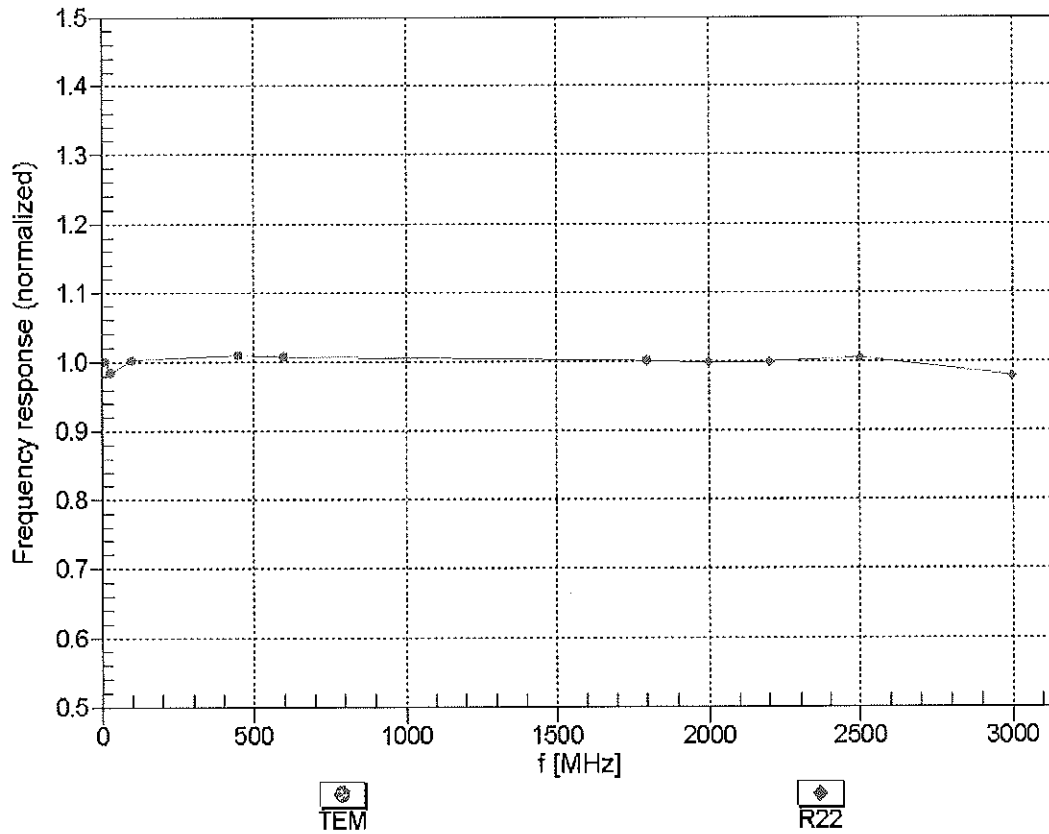

Uncertainty of Frequency Response of E-field: $\pm 6.3\%$ (k=2)

Receiving Pattern (ϕ), $\theta = 0^\circ$

f=600 MHz,TEM

f=1800 MHz,R22

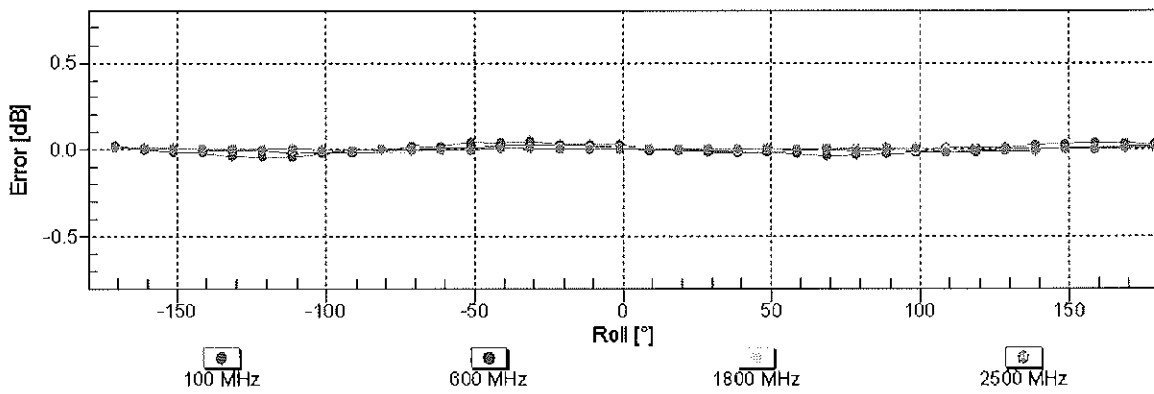
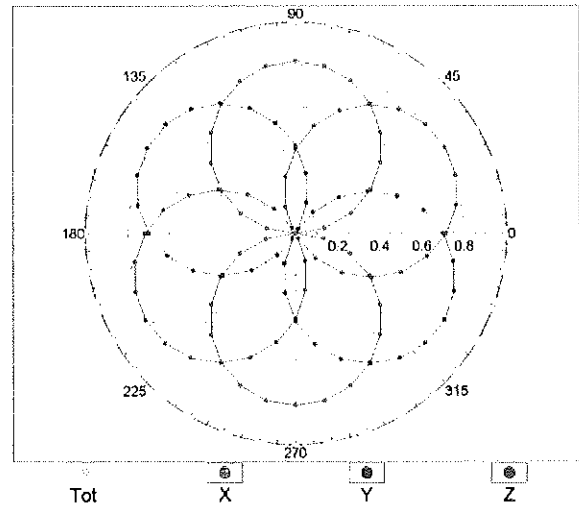
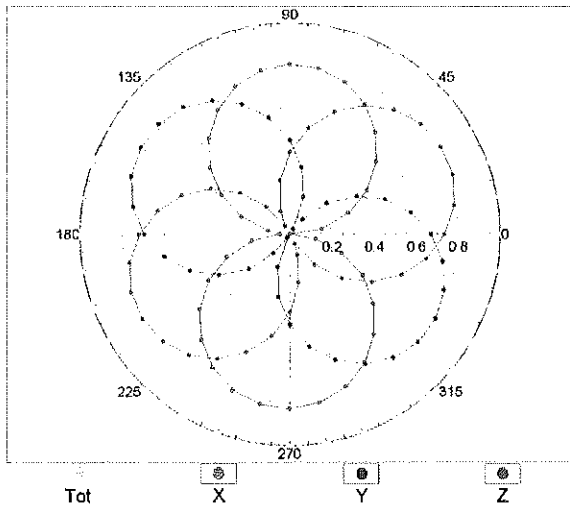

Uncertainty of Axial Isotropy Assessment: $\pm 0.5\%$ (k=2)

Dynamic Range $f(\text{SAR}_{\text{head}})$ (TEM cell , $f_{\text{eval}}=1900 \text{ MHz}$)

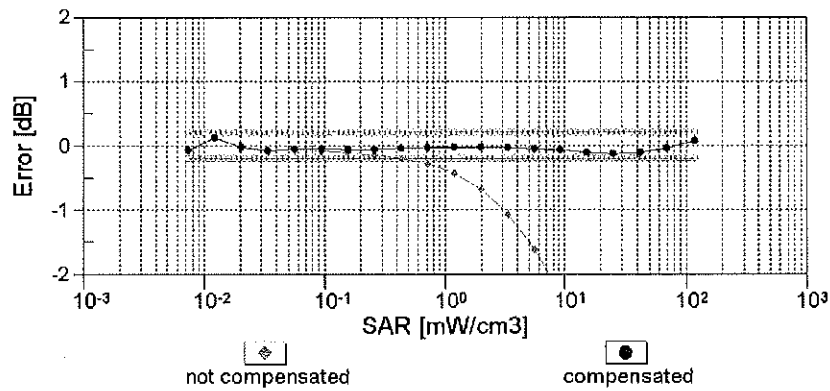
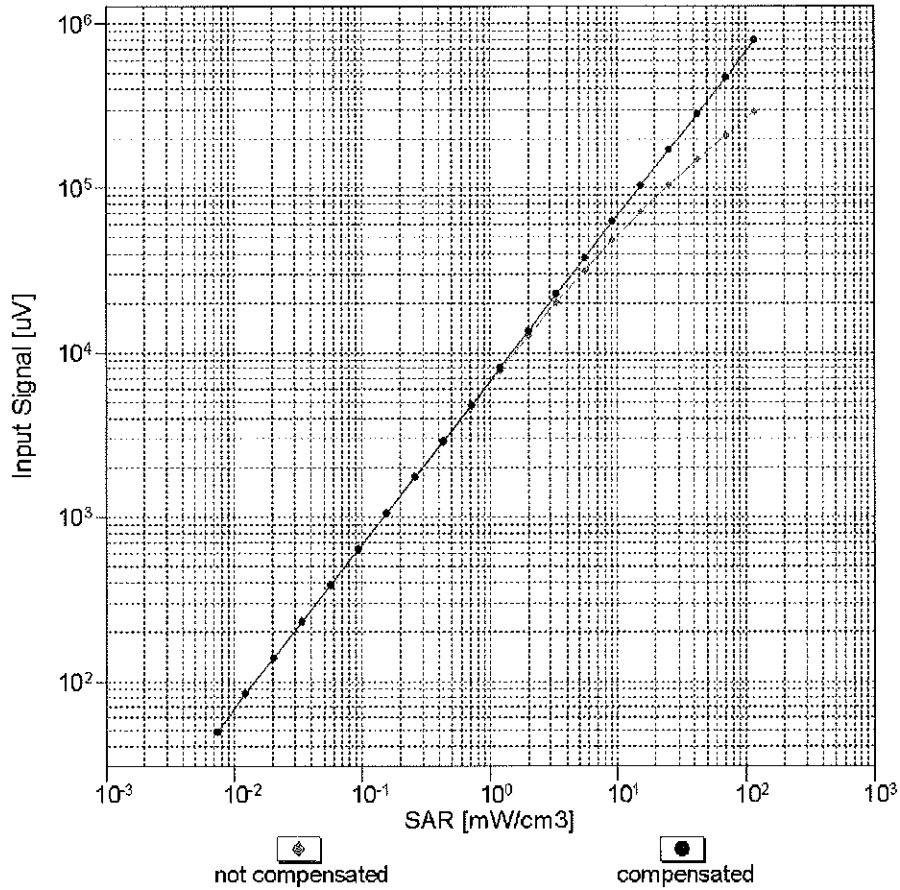

Uncertainty of Linearity Assessment: $\pm 0.6\%$ ($k=2$)

Conversion Factor Assessment

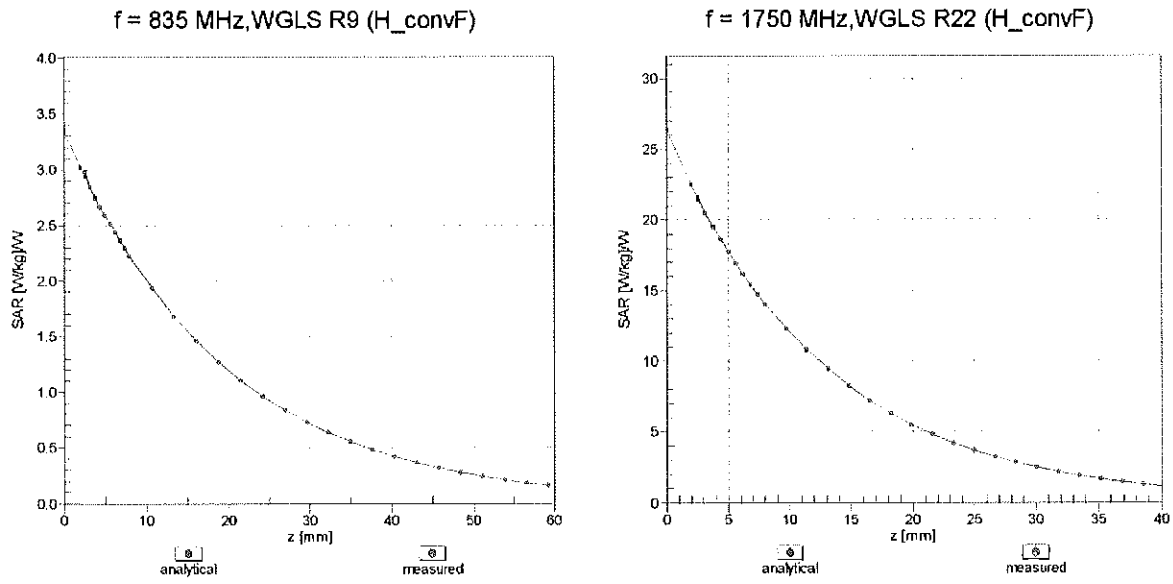

Deviation from Isotropy in Liquid Error (ϕ, ϑ), f = 900 MHz

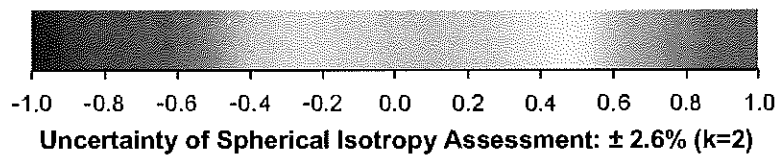
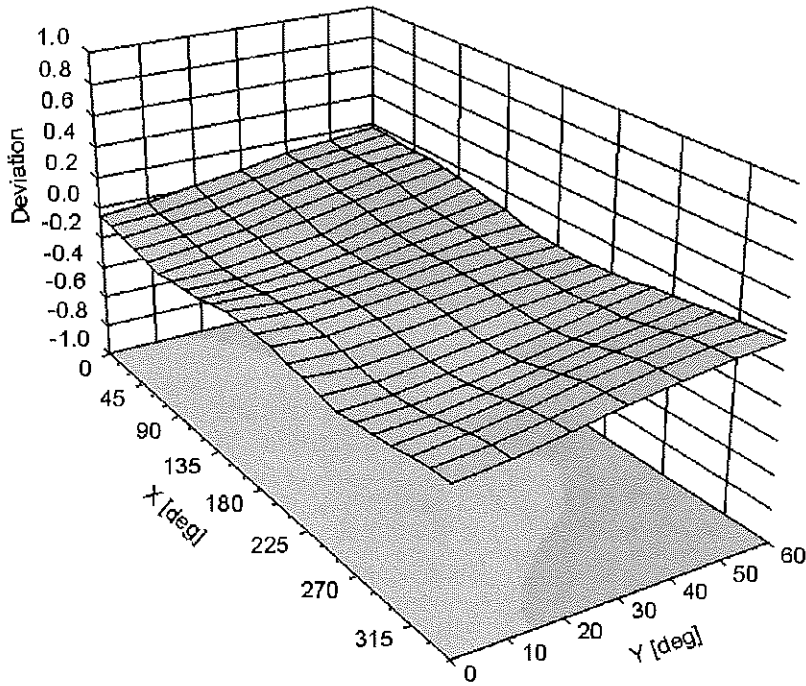

DASY/EASY - Parameters of Probe: ES3DV3 - SN:3263

Other Probe Parameters

Sensor Arrangement	Triangular
Connector Angle (°)	-111.2
Mechanical Surface Detection Mode	enabled
Optical Surface Detection Mode	disabled
Probe Overall Length	337 mm
Probe Body Diameter	10 mm
Tip Length	10 mm
Tip Diameter	4 mm
Probe Tip to Sensor X Calibration Point	2 mm
Probe Tip to Sensor Y Calibration Point	2 mm
Probe Tip to Sensor Z Calibration Point	2 mm
Recommended Measurement Distance from Surface	3 mm

**Calibration Laboratory of
Schmid & Partner
Engineering AG**
Zeughausstrasse 43, 8004 Zurich, Switzerland



S S C S
Schweizerischer Kalibrierdienst
Service suisse d'étalonnage
Servizio svizzero di taratura
Swiss Calibration Service

Accredited by the Swiss Accreditation Service (SAS)
The Swiss Accreditation Service is one of the signatories to the EA
Multilateral Agreement for the recognition of calibration certificates

Accreditation No.: **SCS 108**

Client **PC Test**

Certificate No: **ES3-3288_Sep14/2**

CALIBRATION CERTIFICATE (Replacement of No:ES3-3288_Sep14)

Object **ES3DV3 - SN:3288**

Calibration procedure(s) **QA CAL-01.v9, QA CAL-23.v5, QA CAL-25.v6
Calibration procedure for dosimetric E-field probes** CC
11/12/14

Calibration date: **September 24, 2014**

This calibration certificate documents the traceability to national standards, which realize the physical units of measurements (SI).
The measurements and the uncertainties with confidence probability are given on the following pages and are part of the certificate.

All calibrations have been conducted in the closed laboratory facility: environment temperature (22 ± 3)°C and humidity < 70%.

Calibration Equipment used (M&TE critical for calibration)

Primary Standards	ID	Cal Date (Certificate No.)	Scheduled Calibration
Power meter E4419B	GB41293874	03-Apr-14 (No. 217-01911)	Apr-15
Power sensor E4412A	MY41498087	03-Apr-14 (No. 217-01911)	Apr-15
Reference 3 dB Attenuator	SN: S5054 (3c)	03-Apr-14 (No. 217-01915)	Apr-15
Reference 20 dB Attenuator	SN: S5277 (20x)	03-Apr-14 (No. 217-01919)	Apr-15
Reference 30 dB Attenuator	SN: S5129 (30b)	03-Apr-14 (No. 217-01920)	Apr-15
Reference Probe ES3DV2	SN: 3013	30-Dec-13 (No. ES3-3013_Dec13)	Dec-14
DAE4	SN: 660	13-Dec-13 (No. DAE4-660_Dec13)	Dec-14
Secondary Standards	ID	Check Date (in house)	Scheduled Check
RF generator HP 8648C	US3642U01700	4-Aug-99 (in house check Apr-13)	In house check: Apr-16
Network Analyzer HP 8753E	US37390585	18-Oct-01 (in house check Oct-13)	In house check: Oct-14

	Name	Function	Signature
Calibrated by:	Leif Klysner	Laboratory Technician	
Approved by:	Katja Pokovic	Technical Manager	

Issued: November 3, 2014

This calibration certificate shall not be reproduced except in full without written approval of the laboratory.



Accredited by the Swiss Accreditation Service (SAS)
The Swiss Accreditation Service is one of the signatories to the EA
Multilateral Agreement for the recognition of calibration certificates

Accreditation No.: **SCS 108**

Glossary:

TSL	tissue simulating liquid
NORM _{x,y,z}	sensitivity in free space
ConvF	sensitivity in TSL / NORM _{x,y,z}
DCP	diode compression point
CF	crest factor (1/duty_cycle) of the RF signal
A, B, C, D	modulation dependent linearization parameters
Polarization φ	φ rotation around probe axis
Polarization ϑ	ϑ rotation around an axis that is in the plane normal to probe axis (at measurement center), i.e., ϑ = 0 is normal to probe axis
Connector Angle	information used in DASY system to align probe sensor X to the robot coordinate system

Calibration is Performed According to the Following Standards:

- a) IEEE Std 1528-2013, "IEEE Recommended Practice for Determining the Peak Spatial-Averaged Specific Absorption Rate (SAR) in the Human Head from Wireless Communications Devices: Measurement Techniques", June 2013
- b) IEC 62209-1, "Procedure to measure the Specific Absorption Rate (SAR) for hand-held devices used in close proximity to the ear (frequency range of 300 MHz to 3 GHz)", February 2005

Methods Applied and Interpretation of Parameters:

- *NORM_{x,y,z}*: Assessed for E-field polarization ϑ = 0 (f ≤ 900 MHz in TEM-cell; f > 1800 MHz: R22 waveguide). *NORM_{x,y,z}* are only intermediate values, i.e., the uncertainties of *NORM_{x,y,z}* does not affect the E²-field uncertainty inside TSL (see below *ConvF*).
- *NORM(f)_{x,y,z}* = *NORM_{x,y,z}* * *frequency_response* (see Frequency Response Chart). This linearization is implemented in DASY4 software versions later than 4.2. The uncertainty of the frequency response is included in the stated uncertainty of *ConvF*.
- *DCP_{x,y,z}*: DCP are numerical linearization parameters assessed based on the data of power sweep with CW signal (no uncertainty required). DCP does not depend on frequency nor media.
- *PAR*: PAR is the Peak to Average Ratio that is not calibrated but determined based on the signal characteristics
- *A_{x,y,z}*; *B_{x,y,z}*; *C_{x,y,z}*; *D_{x,y,z}*; *VR_{x,y,z}*; *A*, *B*, *C*, *D* are numerical linearization parameters assessed based on the data of power sweep for specific modulation signal. The parameters do not depend on frequency nor media. *VR* is the maximum calibration range expressed in RMS voltage across the diode.
- *ConvF* and *Boundary Effect Parameters*: Assessed in flat phantom using E-field (or Temperature Transfer Standard for f ≤ 800 MHz) and inside waveguide using analytical field distributions based on power measurements for f > 800 MHz. The same setups are used for assessment of the parameters applied for boundary compensation (alpha, depth) of which typical uncertainty values are given. These parameters are used in DASY4 software to improve probe accuracy close to the boundary. The sensitivity in TSL corresponds to *NORM_{x,y,z}* * *ConvF* whereby the uncertainty corresponds to that given for *ConvF*. A frequency dependent *ConvF* is used in DASY version 4.4 and higher which allows extending the validity from ± 50 MHz to ± 100 MHz.
- *Spherical isotropy (3D deviation from isotropy)*: in a field of low gradients realized using a flat phantom exposed by a patch antenna.
- *Sensor Offset*: The sensor offset corresponds to the offset of virtual measurement center from the probe tip (on probe axis). No tolerance required.
- *Connector Angle*: The angle is assessed using the information gained by determining the *NORM_x* (no uncertainty required).

Probe ES3DV3

SN:3288

Manufactured:	July 6, 2010
Repaired:	September 18, 2014
Calibrated:	September 24, 2014

Calibrated for DASY/EASY Systems
(Note: non-compatible with DASY2 system!)

DASY/EASY - Parameters of Probe: ES3DV3 - SN:3288

Basic Calibration Parameters

	Sensor X	Sensor Y	Sensor Z	Unc (k=2)
Norm ($\mu\text{V}/(\text{V}/\text{m})^2$) ^A	1.05	1.16	0.92	$\pm 10.1 \%$
DCP (mV) ^B	105.1	104.6	106.7	

Modulation Calibration Parameters

UID	Communication System Name		A dB	B dB $\sqrt{\mu\text{V}}$	C	D dB	VR mV	Unc ^E (k=2)
0	CW	X	0.0	0.0	1.0	0.00	195.8	$\pm 3.5 \%$
		Y	0.0	0.0	1.0		175.9	
		Z	0.0	0.0	1.0		177.1	
10010- CAA	SAR Validation (Square, 100ms, 10ms)	X	2.71	61.9	11.4	10.00	40.3	$\pm 2.2 \%$
		Y	2.37	60.2	11.2		42.6	
		Z	1.54	56.6	8.9		41.2	
10011- CAB	UMTS-FDD (WCDMA)	X	3.29	67.1	18.4	2.91	133.8	$\pm 0.5 \%$
		Y	3.43	67.9	18.9		139.5	
		Z	3.45	68.1	18.9		141.3	
10012- CAA	IEEE 802.11b WiFi 2.4 GHz (DSSS, 1 Mbps)	X	2.99	68.9	18.6	1.87	135.1	$\pm 0.7 \%$
		Y	3.59	72.4	20.4		140.7	
		Z	3.54	72.4	20.3		143.0	
10013- CAA	IEEE 802.11g WiFi 2.4 GHz (DSSS-OFDM, 6 Mbps)	X	11.15	70.8	23.3	9.46	132.3	$\pm 3.5 \%$
		Y	11.29	70.8	23.2		141.1	
		Z	11.07	70.7	23.2		139.2	
10021- DAB	GSM-FDD (TDMA, GMSK)	X	14.71	90.5	24.5	9.39	149.0	$\pm 1.9 \%$
		Y	16.40	92.8	26.0		131.3	
		Z	11.34	87.2	23.6		126.1	
10023- DAB	GPRS-FDD (TDMA, GMSK, TN 0)	X	15.91	92.2	25.3	9.57	138.9	$\pm 2.5 \%$
		Y	21.25	96.9	27.2		142.0	
		Z	11.68	87.2	23.5		145.9	
10024- DAB	GPRS-FDD (TDMA, GMSK, TN 0-1)	X	38.62	99.8	24.7	6.56	123.8	$\pm 2.2 \%$
		Y	36.71	99.7	25.2		128.1	
		Z	36.56	99.4	24.5		129.5	
10027- DAB	GPRS-FDD (TDMA, GMSK, TN 0-1-2)	X	56.60	99.6	22.6	4.80	138.8	$\pm 1.9 \%$
		Y	46.94	99.9	23.7		149.9	
		Z	51.17	99.8	22.9		144.9	
10028- DAB	GPRS-FDD (TDMA, GMSK, TN 0-1-2-3)	X	70.88	100.0	21.6	3.55	147.5	$\pm 1.9 \%$
		Y	52.58	99.8	22.6		129.4	
		Z	76.98	99.8	21.2		128.7	
10032- CAA	IEEE 802.15.1 Bluetooth (GFSK, DH5)	X	98.89	99.5	18.9	1.16	135.8	$\pm 1.4 \%$
		Y	78.39	99.6	19.5		141.7	
		Z	95.21	95.5	17.1		143.4	
10039- CAB	CDMA2000 (1xRTT, RC1)	X	4.72	66.7	18.9	4.57	133.7	$\pm 0.9 \%$
		Y	4.85	67.1	19.1		137.7	
		Z	4.81	67.4	19.2		141.9	

10081-CAB	CDMA2000 (1xRTT, RC3)	X	3.91	66.3	18.6	3.97	129.5	±0.7 %
		Y	4.00	66.6	18.7		133.7	
		Z	3.99	66.8	18.8		137.5	
10098-CAB	UMTS-FDD (HSUPA, Subtest 2)	X	4.63	66.9	18.7	3.98	141.4	±0.7 %
		Y	4.78	67.5	19.0		147.7	
		Z	4.57	66.8	18.6		127.8	
10100-CAB	LTE-FDD (SC-FDMA, 100% RB, 20 MHz, QPSK)	X	6.59	68.2	20.1	5.67	149.2	±1.4 %
		Y	6.36	67.3	19.6		130.7	
		Z	6.36	67.5	19.6		133.6	
10108-CAB	LTE-FDD (SC-FDMA, 100% RB, 10 MHz, QPSK)	X	6.44	67.8	20.0	5.80	146.6	±1.4 %
		Y	6.23	66.8	19.4		128.8	
		Z	6.24	67.1	19.6		131.4	
10110-CAB	LTE-FDD (SC-FDMA, 100% RB, 5 MHz, QPSK)	X	6.08	67.1	19.6	5.75	143.2	±1.4 %
		Y	6.20	67.4	19.8		148.0	
		Z	5.92	66.6	19.3		128.5	
10114-CAA	IEEE 802.11n (HT Greenfield, 13.5 Mbps, BPSK)	X	10.32	69.3	21.5	8.10	137.0	±2.2 %
		Y	10.31	69.1	21.4		143.5	
		Z	10.37	69.5	21.6		146.1	
10117-CAA	IEEE 802.11n (HT Mixed, 13.5 Mbps, BPSK)	X	10.35	69.4	21.6	8.07	138.3	±2.2 %
		Y	10.36	69.3	21.4		146.4	
		Z	10.42	69.6	21.6		149.0	
10151-CAB	LTE-TDD (SC-FDMA, 50% RB, 20 MHz, QPSK)	X	9.95	75.7	26.2	9.28	134.9	±3.3 %
		Y	10.37	76.0	26.1		146.6	
		Z	9.77	75.4	26.0		142.5	
10154-CAB	LTE-FDD (SC-FDMA, 50% RB, 10 MHz, QPSK)	X	6.12	67.2	19.7	5.75	144.9	±1.4 %
		Y	6.21	67.4	19.8		148.8	
		Z	5.91	66.5	19.3		128.7	
10160-CAB	LTE-FDD (SC-FDMA, 50% RB, 15 MHz, QPSK)	X	6.28	66.7	19.4	5.82	125.5	±1.2 %
		Y	6.37	66.8	19.4		129.7	
		Z	6.36	67.1	19.6		132.9	
10169-CAB	LTE-FDD (SC-FDMA, 1 RB, 20 MHz, QPSK)	X	5.08	67.6	20.2	5.73	147.0	±1.2 %
		Y	4.95	66.6	19.6		128.6	
		Z	4.91	66.9	19.8		131.2	
10172-CAB	LTE-TDD (SC-FDMA, 1 RB, 20 MHz, QPSK)	X	8.18	77.2	27.2	9.21	123.4	±2.7 %
		Y	8.37	76.6	26.6		129.5	
		Z	7.97	76.7	26.9		128.7	
10175-CAB	LTE-FDD (SC-FDMA, 1 RB, 10 MHz, QPSK)	X	5.05	67.4	20.1	5.72	146.2	±1.4 %
		Y	5.10	67.3	20.0		142.8	
		Z	4.87	66.7	19.6		129.6	
10181-CAB	LTE-FDD (SC-FDMA, 1 RB, 15 MHz, QPSK)	X	5.04	67.4	20.0	5.72	145.5	±1.2 %
		Y	5.12	67.4	20.0		143.4	
		Z	4.87	66.7	19.6		129.9	
10193-CAA	IEEE 802.11n (HT Greenfield, 6.5 Mbps, BPSK)	X	9.92	68.9	21.4	8.09	131.0	±2.2 %
		Y	9.84	68.5	21.1		130.0	
		Z	9.94	69.0	21.4		138.6	

10196-CAA	IEEE 802.11n (HT Mixed, 6.5 Mbps, BPSK)	X	9.90	68.9	21.4	8.10	130.8	±2.2 %
		Y	9.81	68.4	21.0		131.4	
		Z	9.95	69.1	21.5		140.5	
10219-CAA	IEEE 802.11n (HT Mixed, 7.2 Mbps, BPSK)	X	9.81	68.8	21.3	8.03	130.0	±2.2 %
		Y	9.89	68.9	21.3		138.1	
		Z	9.89	69.1	21.5		140.5	
10222-CAA	IEEE 802.11n (HT Mixed, 15 Mbps, BPSK)	X	10.25	69.2	21.4	8.06	137.1	±2.2 %
		Y	10.30	69.2	21.4		144.4	
		Z	10.38	69.6	21.6		148.4	
10225-CAB	UMTS-FDD (HSPA+)	X	6.90	66.8	19.3	5.97	132.8	±1.4 %
		Y	7.09	67.3	19.6		142.0	
		Z	7.04	67.4	19.6		143.5	
10237-CAB	LTE-TDD (SC-FDMA, 1 RB, 10 MHz, QPSK)	X	9.61	81.9	29.6	9.21	149.3	±2.7 %
		Y	8.66	77.6	27.1		133.7	
		Z	8.20	77.5	27.3		132.2	
10252-CAB	LTE-TDD (SC-FDMA, 50% RB, 10 MHz, QPSK)	X	9.16	74.5	25.8	9.24	126.3	±3.0 %
		Y	9.62	75.0	25.8		137.4	
		Z	9.16	74.8	25.9		135.2	
10267-CAB	LTE-TDD (SC-FDMA, 100% RB, 10 MHz, QPSK)	X	9.97	75.7	26.3	9.30	133.7	±3.3 %
		Y	10.38	75.9	26.1		146.1	
		Z	9.91	75.7	26.3		143.8	
10274-CAB	UMTS-FDD (HSUPA, Subtest 5, 3GPP Rel8.10)	X	5.86	66.6	18.7	4.87	129.9	±0.9 %
		Y	6.01	67.1	19.0		135.7	
		Z	5.95	67.1	19.0		139.4	
10275-CAB	UMTS-FDD (HSUPA, Subtest 5, 3GPP Rel8.4)	X	4.40	66.7	18.6	3.96	136.4	±0.7 %
		Y	4.55	67.3	19.0		138.3	
		Z	4.56	67.6	19.1		144.3	
10291-AAB	CDMA2000, RC3, SO55, Full Rate	X	3.64	66.9	18.7	3.46	127.4	±0.5 %
		Y	3.77	67.6	19.1		130.2	
		Z	3.72	67.5	19.0		134.4	
10292-AAB	CDMA2000, RC3, SO32, Full Rate	X	3.58	67.0	18.7	3.39	128.4	±0.5 %
		Y	3.73	67.7	19.1		132.7	
		Z	3.69	67.8	19.1		136.1	
10297-AAA	LTE-FDD (SC-FDMA, 50% RB, 20 MHz, QPSK)	X	6.43	67.7	19.9	5.81	145.5	±1.4 %
		Y	6.49	67.7	19.9		149.5	
		Z	6.23	67.0	19.6		129.5	
10311-AAA	LTE-FDD (SC-FDMA, 100% RB, 15 MHz, QPSK)	X	6.74	67.3	19.8	6.06	126.7	±1.4 %
		Y	6.83	67.5	19.8		132.9	
		Z	6.81	67.6	19.9		135.8	
10315-AAA	IEEE 802.11b WiFi 2.4 GHz (DSSS, 1 Mbps, 96pc duty cycle)	X	3.00	69.9	19.4	1.71	133.9	±0.5 %
		Y	3.30	71.5	20.1		141.0	
		Z	3.22	71.4	20.0		142.9	
10316-AAA	IEEE 802.11g WiFi 2.4 GHz (ERP-OFDM, 6 Mbps, 96pc duty cycle)	X	10.17	69.2	21.8	8.36	130.5	±2.5 %
		Y	10.20	69.1	21.6		138.4	
		Z	10.20	69.4	21.8		140.7	

10403-AAB	CDMA2000 (1xEV-DO, Rev. 0)	X	4.75	68.3	18.8	3.76	138.5	±0.7 %
		Y	5.00	69.1	19.2		146.7	
		Z	4.92	69.2	19.1		148.5	
10404-AAB	CDMA2000 (1xEV-DO, Rev. A)	X	4.73	68.6	18.9	3.77	136.3	±0.7 %
		Y	4.97	69.4	19.4		143.7	
		Z	4.91	69.6	19.3		146.0	
10415-AAA	IEEE 802.11b WiFi 2.4 GHz (DSSS, 1 Mbps, 99pc duty cycle)	X	2.65	68.1	18.5	1.54	135.2	±0.5 %
		Y	3.05	70.8	19.9		140.7	
		Z	2.87	69.8	19.3		144.8	
10416-AAA	IEEE 802.11g WiFi 2.4 GHz (ERP-OFDM, 6 Mbps, 99pc duty cycle)	X	10.00	69.0	21.5	8.23	130.8	±2.2 %
		Y	10.06	68.9	21.4		138.6	
		Z	10.08	69.3	21.7		141.6	

The reported uncertainty of measurement is stated as the standard uncertainty of measurement multiplied by the coverage factor $k=2$, which for a normal distribution corresponds to a coverage probability of approximately 95%.

^A The uncertainties of NormX,Y,Z do not affect the E^2 -field uncertainty inside TSL (see Pages 8 and 9).

^B Numerical linearization parameter: uncertainty not required.

^E Uncertainty is determined using the max. deviation from linear response applying rectangular distribution and is expressed for the square of the field value.

DASY/EASY - Parameters of Probe: ES3DV3 - SN:3288

Calibration Parameter Determined in Head Tissue Simulating Media

f (MHz) ^C	Relative Permittivity ^F	Conductivity (S/m) ^F	ConvF X	ConvF Y	ConvF Z	Alpha ^G	Depth ^G (mm)	Unct. (k=2)
750	41.9	0.89	6.81	6.81	6.81	0.37	1.70	± 12.0 %
835	41.5	0.90	6.51	6.51	6.51	0.45	1.52	± 12.0 %
1750	40.1	1.37	5.38	5.38	5.38	0.44	1.58	± 12.0 %
1900	40.0	1.40	5.17	5.17	5.17	0.80	1.18	± 12.0 %
2450	39.2	1.80	4.56	4.56	4.56	0.80	1.21	± 12.0 %
2600	39.0	1.96	4.44	4.44	4.44	0.80	1.22	± 12.0 %

^C Frequency validity above 300 MHz of ± 100 MHz only applies for DASY v4.4 and higher (see Page 2), else it is restricted to ± 50 MHz. The uncertainty is the RSS of the ConvF uncertainty at calibration frequency and the uncertainty for the indicated frequency band. Frequency validity below 300 MHz is ± 10, 25, 40, 50 and 70 MHz for ConvF assessments at 30, 64, 128, 150 and 220 MHz respectively. Above 5 GHz frequency validity can be extended to ± 110 MHz.

^F At frequencies below 3 GHz, the validity of tissue parameters (ϵ and σ) can be relaxed to ± 10% if liquid compensation formula is applied to measured SAR values. At frequencies above 3 GHz, the validity of tissue parameters (ϵ and σ) is restricted to ± 5%. The uncertainty is the RSS of the ConvF uncertainty for indicated target tissue parameters.

^G Alpha/Depth are determined during calibration. SPEAG warrants that the remaining deviation due to the boundary effect after compensation is always less than ± 1% for frequencies below 3 GHz and below ± 2% for frequencies between 3-6 GHz at any distance larger than half the probe tip diameter from the boundary.

DASY/EASY - Parameters of Probe: ES3DV3 - SN:3288

Calibration Parameter Determined in Body Tissue Simulating Media

f (MHz) ^C	Relative Permittivity ^F	Conductivity (S/m) ^F	ConvF X	ConvF Y	ConvF Z	Alpha ^G	Depth ^G (mm)	Unct. (k=2)
750	55.5	0.96	6.38	6.38	6.38	0.31	1.89	± 12.0 %
835	55.2	0.97	6.32	6.32	6.32	0.55	1.39	± 12.0 %
1750	53.4	1.49	5.03	5.03	5.03	0.57	1.44	± 12.0 %
1900	53.3	1.52	4.82	4.82	4.82	0.51	1.54	± 12.0 %
2450	52.7	1.95	4.36	4.36	4.36	0.71	1.07	± 12.0 %
2600	52.5	2.16	4.22	4.22	4.22	0.80	1.07	± 12.0 %

^C Frequency validity above 300 MHz of ± 100 MHz only applies for DASY v4.4 and higher (see Page 2), else it is restricted to ± 50 MHz. The uncertainty is the RSS of the ConvF uncertainty at calibration frequency and the uncertainty for the indicated frequency band. Frequency validity below 300 MHz is ± 10, 25, 40, 50 and 70 MHz for ConvF assessments at 30, 64, 128, 150 and 220 MHz respectively. Above 5 GHz frequency validity can be extended to ± 110 MHz.

^F At frequencies below 3 GHz, the validity of tissue parameters (ϵ and σ) can be relaxed to ± 10% if liquid compensation formula is applied to measured SAR values. At frequencies above 3 GHz, the validity of tissue parameters (ϵ and σ) is restricted to ± 5%. The uncertainty is the RSS of the ConvF uncertainty for indicated target tissue parameters.

^G Alpha/Depth are determined during calibration. SPEAG warrants that the remaining deviation due to the boundary effect after compensation is always less than ± 1% for frequencies below 3 GHz and below ± 2% for frequencies between 3-6 GHz at any distance larger than half the probe tip diameter from the boundary.

Frequency Response of E-Field

(TEM-Cell:ifi1110 EXX, Waveguide: R22)

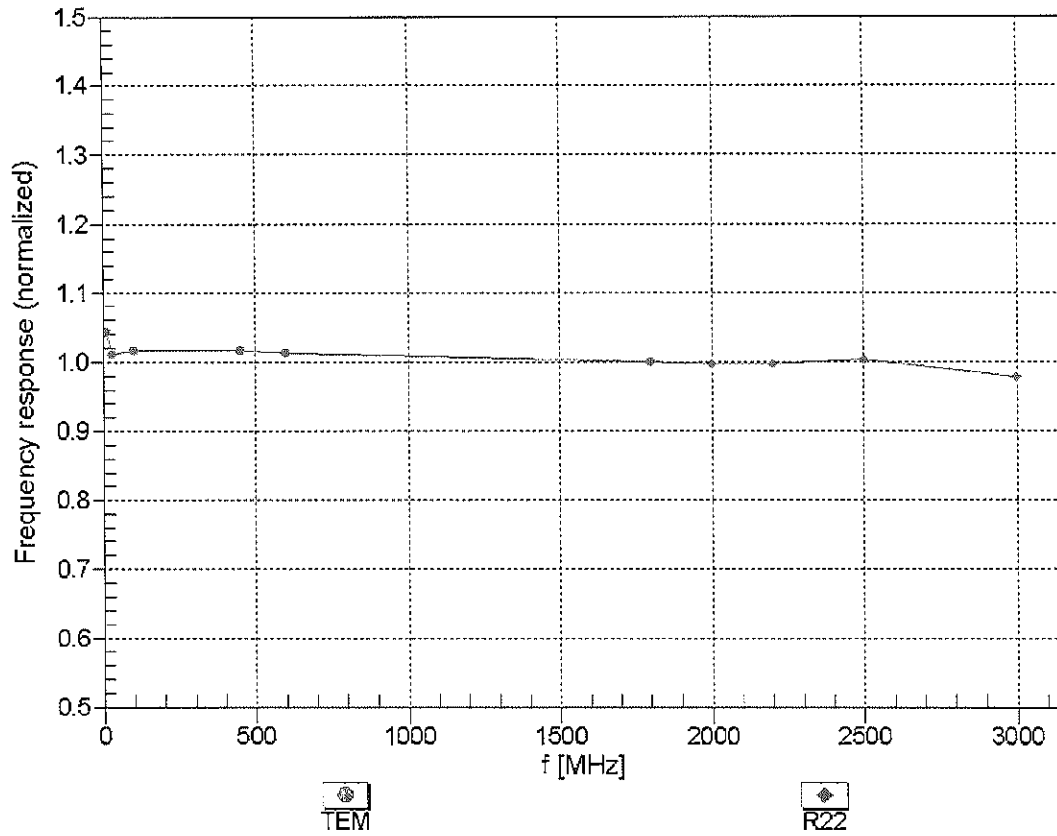

Uncertainty of Frequency Response of E-field: $\pm 6.3\%$ (k=2)

Receiving Pattern (ϕ), $\vartheta = 0^\circ$

f=600 MHz, TEM

f=1800 MHz, R22

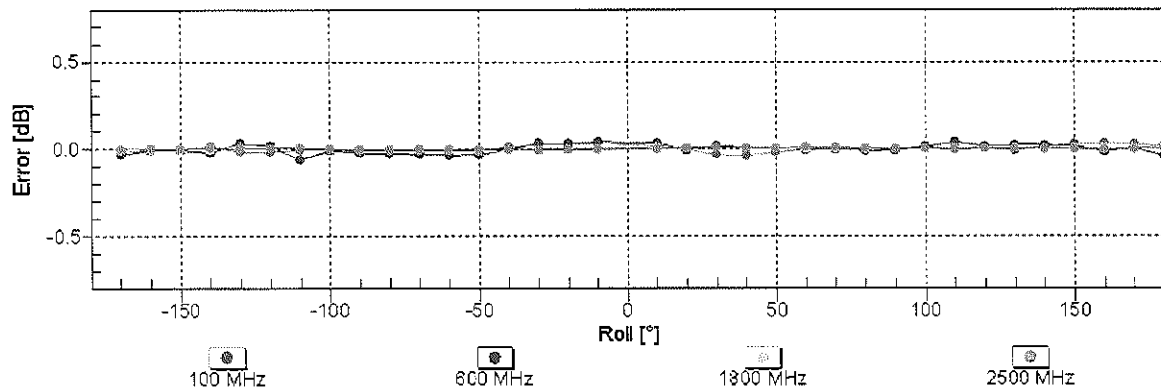
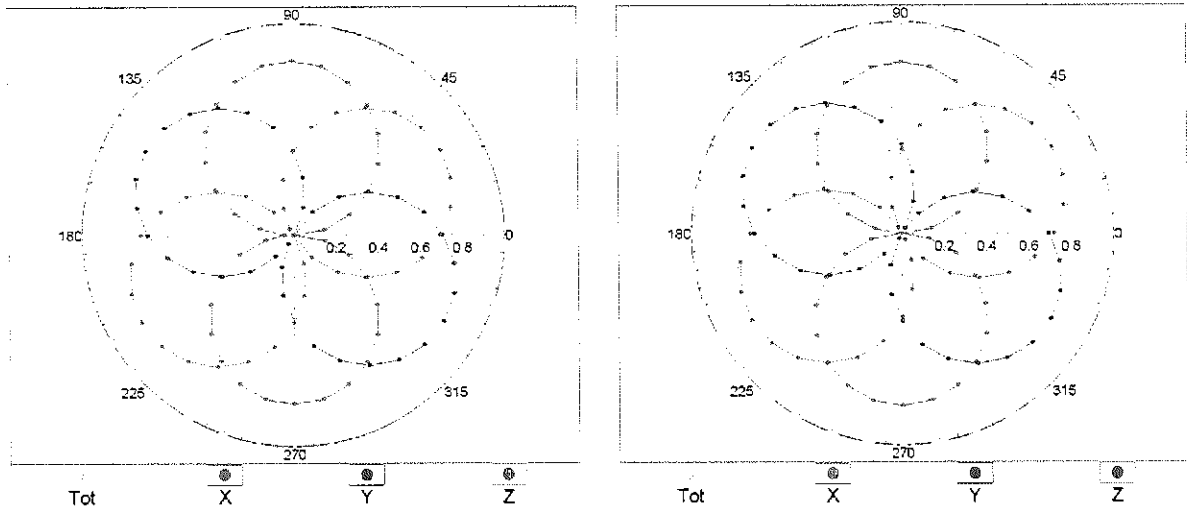

Uncertainty of Axial Isotropy Assessment: $\pm 0.5\%$ ($k=2$)

Dynamic Range $f(\text{SAR}_{\text{head}})$ (TEM cell , $f_{\text{eval}}= 1900 \text{ MHz}$)

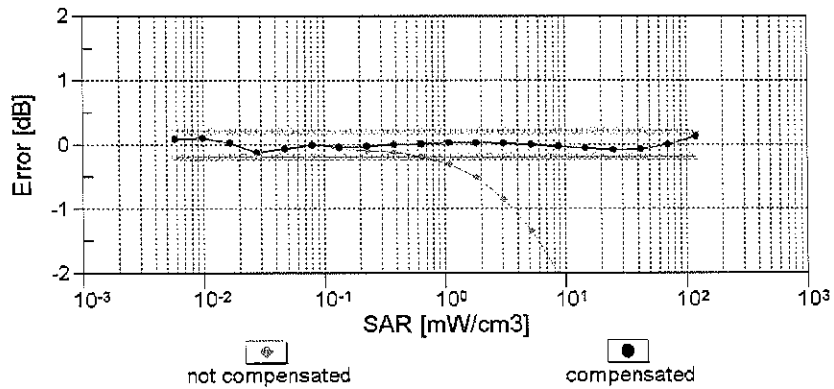
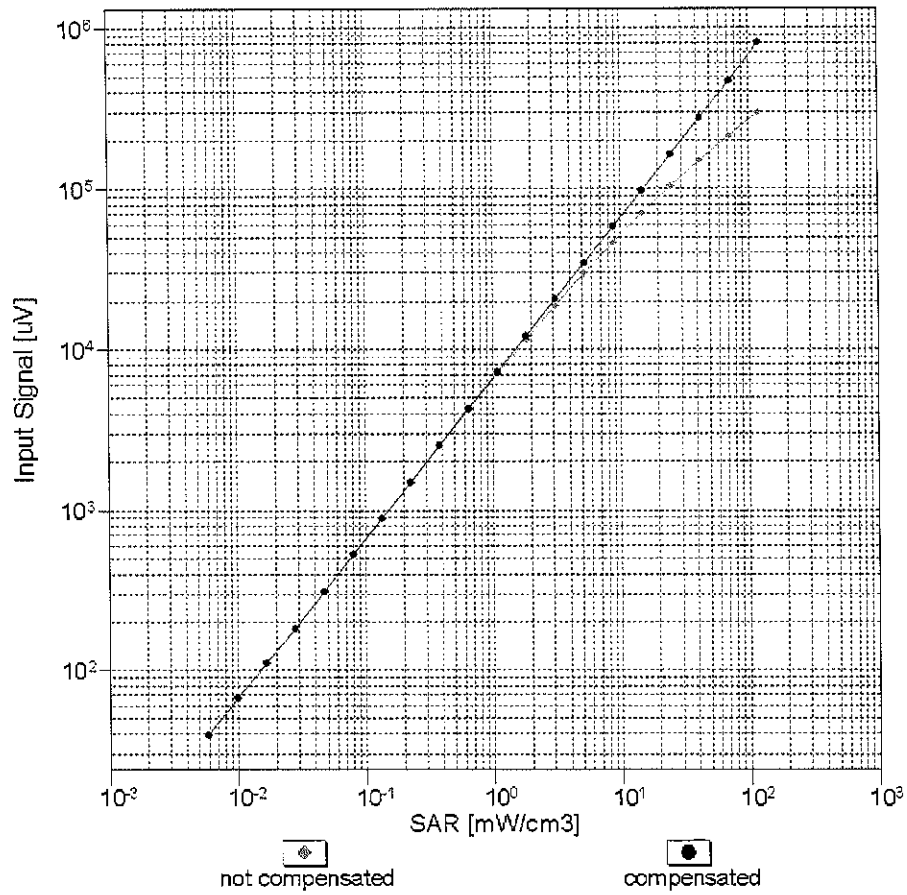

Uncertainty of Linearity Assessment: $\pm 0.6\%$ ($k=2$)

Conversion Factor Assessment

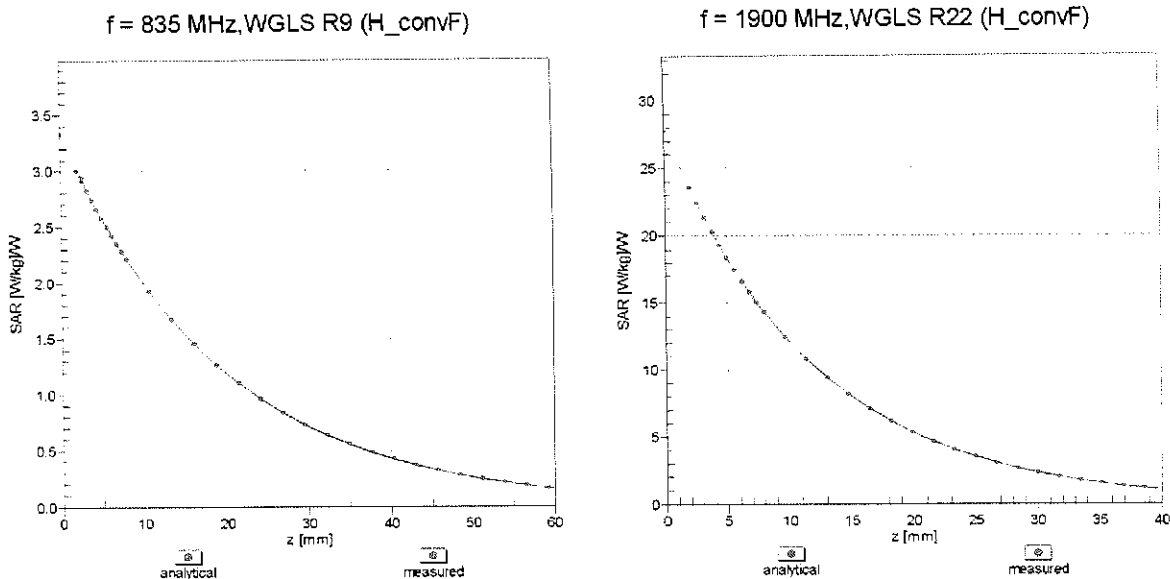

Deviation from Isotropy in Liquid

Error (ϕ, θ), $f = 900$ MHz

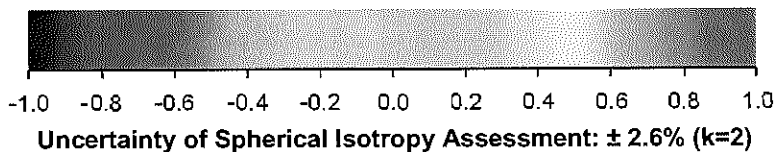
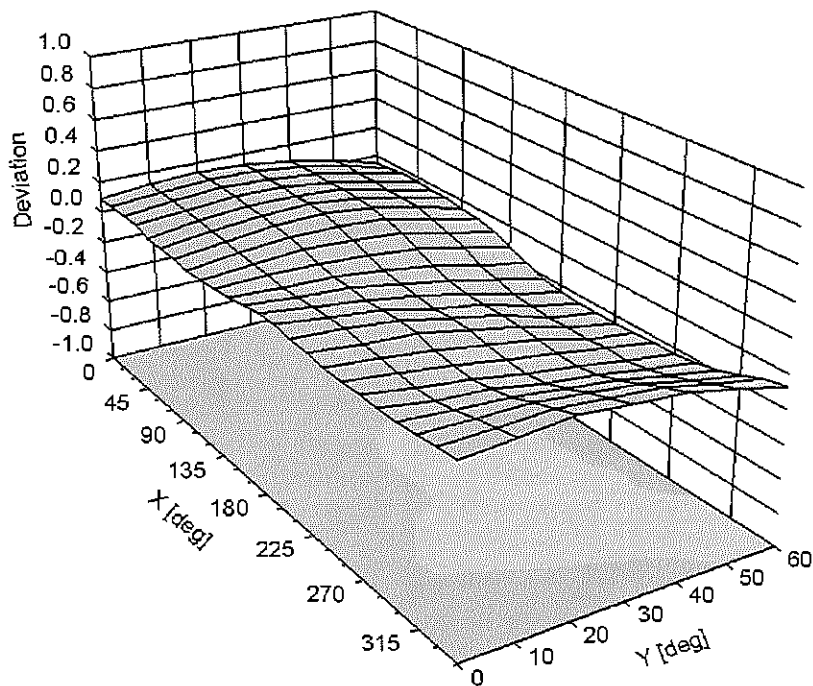

DASY/EASY - Parameters of Probe: ES3DV3 - SN:3288

Other Probe Parameters

Sensor Arrangement	Triangular
Connector Angle (°)	-110
Mechanical Surface Detection Mode	enabled
Optical Surface Detection Mode	disabled
Probe Overall Length	337 mm
Probe Body Diameter	10 mm
Tip Length	10 mm
Tip Diameter	4 mm
Probe Tip to Sensor X Calibration Point	2 mm
Probe Tip to Sensor Y Calibration Point	2 mm
Probe Tip to Sensor Z Calibration Point	2 mm
Recommended Measurement Distance from Surface	3 mm

**Calibration Laboratory of
Schmid & Partner
Engineering AG**
Zeughausstrasse 43, 8004 Zurich, Switzerland



S Schweizerischer Kallbrierdienst
C Service suisse d'étalonnage
S Servizio svizzero di taratura
Swiss Calibration Service

Accredited by the Swiss Accreditation Service (SAS)
The Swiss Accreditation Service is one of the signatories to the EA
Multilateral Agreement for the recognition of calibration certificates

Accreditation No.: **SCS 108**

Client **PC Test**

Certificate No: **ES3-3332_Sep14/2**

CALIBRATION CERTIFICATE (Replacement of No: ES3-3332_Sep14)

Object **ES3DV3 - SN:3332**

Calibration procedure(s) **QA CAL-01.v9, QA CAL-23.v5, QA CAL-25.v6**
Calibration procedure for dosimetric E-field probes CC
12/12/14

Calibration date: **September 18, 2014**

This calibration certificate documents the traceability to national standards, which realize the physical units of measurements (SI).
The measurements and the uncertainties with confidence probability are given on the following pages and are part of the certificate.

All calibrations have been conducted in the closed laboratory facility: environment temperature (22 ± 3)°C and humidity < 70%.

Calibration Equipment used (M&TE critical for calibration)

Primary Standards	ID	Cal Date (Certificate No.)	Scheduled Calibration
Power meter E4419B	GB41293874	03-Apr-14 (No. 217-01911)	Apr-15
Power sensor E4412A	MY41498087	03-Apr-14 (No. 217-01911)	Apr-15
Reference 3 dB Attenuator	SN: S5054 (3c)	03-Apr-14 (No. 217-01915)	Apr-15
Reference 20 dB Attenuator	SN: S5277 (20x)	03-Apr-14 (No. 217-01919)	Apr-15
Reference 30 dB Attenuator	SN: S5129 (30b)	03-Apr-14 (No. 217-01920)	Apr-15
Reference Probe ES3DV2	SN: 3013	30-Dec-13 (No. ES3-3013_Dec13)	Dec-14
DAE4	SN: 660	13-Dec-13 (No. DAE4-660_Dec13)	Dec-14
Secondary Standards	ID	Check Date (in house)	Scheduled Check
RF generator HP 8648C	US3642U01700	4-Aug-99 (in house check Apr-13)	in house check: Apr-16
Network Analyzer HP 8753E	US37390585	18-Oct-01 (in house check Oct-13)	in house check: Oct-14

	Name	Function	Signature
Calibrated by:	Israe El-Naouq	Laboratory Technician	
Approved by:	Katja Pokovic	Technical Manager	
			Issued: November 3, 2014

This calibration certificate shall not be reproduced except in full without written approval of the laboratory.



Accredited by the Swiss Accreditation Service (SAS)
The Swiss Accreditation Service is one of the signatories to the EA
Multilateral Agreement for the recognition of calibration certificates

Accreditation No.: **SCS 108**

Glossary:

TSL	tissue simulating liquid
NORM _{x,y,z}	sensitivity in free space
ConvF	sensitivity in TSL / NORM _{x,y,z}
DCP	diode compression point
CF	crest factor (1/duty_cycle) of the RF signal
A, B, C, D	modulation dependent linearization parameters
Polarization φ	φ rotation around probe axis
Polarization ϑ	ϑ rotation around an axis that is in the plane normal to probe axis (at measurement center), i.e., $\vartheta = 0$ is normal to probe axis
Connector Angle	information used in DASY system to align probe sensor X to the robot coordinate system

Calibration is Performed According to the Following Standards:

- IEEE Std 1528-2013, "IEEE Recommended Practice for Determining the Peak Spatial-Averaged Specific Absorption Rate (SAR) in the Human Head from Wireless Communications Devices: Measurement Techniques", June 2013
- IEC 62209-1, "Procedure to measure the Specific Absorption Rate (SAR) for hand-held devices used in close proximity to the ear (frequency range of 300 MHz to 3 GHz)", February 2005

Methods Applied and Interpretation of Parameters:

- NORM_{x,y,z}**: Assessed for E-field polarization $\vartheta = 0$ ($f \leq 900$ MHz in TEM-cell; $f > 1800$ MHz: R22 waveguide). NORM_{x,y,z} are only intermediate values, i.e., the uncertainties of NORM_{x,y,z} does not affect the E²-field uncertainty inside TSL (see below ConvF).
- NORM(f)_{x,y,z}** = NORM_{x,y,z} * frequency_response (see Frequency Response Chart). This linearization is implemented in DASY4 software versions later than 4.2. The uncertainty of the frequency response is included in the stated uncertainty of ConvF.
- DCP_{x,y,z}**: DCP are numerical linearization parameters assessed based on the data of power sweep with CW signal (no uncertainty required). DCP does not depend on frequency nor media.
- PAR**: PAR is the Peak to Average Ratio that is not calibrated but determined based on the signal characteristics
- A_{x,y,z}; B_{x,y,z}; C_{x,y,z}; D_{x,y,z}; VR_{x,y,z}**: A, B, C, D are numerical linearization parameters assessed based on the data of power sweep for specific modulation signal. The parameters do not depend on frequency nor media. VR is the maximum calibration range expressed in RMS voltage across the diode.
- ConvF and Boundary Effect Parameters**: Assessed in flat phantom using E-field (or Temperature Transfer Standard for $f \leq 800$ MHz) and inside waveguide using analytical field distributions based on power measurements for $f > 800$ MHz. The same setups are used for assessment of the parameters applied for boundary compensation (alpha, depth) of which typical uncertainty values are given. These parameters are used in DASY4 software to improve probe accuracy close to the boundary. The sensitivity in TSL corresponds to NORM_{x,y,z} * ConvF whereby the uncertainty corresponds to that given for ConvF. A frequency dependent ConvF is used in DASY version 4.4 and higher which allows extending the validity from ± 50 MHz to ± 100 MHz.
- Spherical Isotropy (3D deviation from Isotropy)**: in a field of low gradients realized using a flat phantom exposed by a patch antenna.
- Sensor Offset**: The sensor offset corresponds to the offset of virtual measurement center from the probe tip (on probe axis). No tolerance required.
- Connector Angle**: The angle is assessed using the information gained by determining the NORM_x (no uncertainty required).

Probe ES3DV3

SN:3332

Manufactured: January 24, 2012
Calibrated: September 18, 2014

Calibrated for DASY/EASY Systems
(Note: non-compatible with DASY2 system!)

DASY/EASY - Parameters of Probe: ES3DV3 - SN:3332

Basic Calibration Parameters

	Sensor X	Sensor Y	Sensor Z	Unc (k=2)
Norm ($\mu\text{V}/(\text{V}/\text{m})^2$) ^A	0.94	1.15	0.98	$\pm 10.1 \%$
DCP (mV) ^B	105.8	103.8	112.4	

Modulation Calibration Parameters

UID	Communication System Name		A dB	B dB $\sqrt{\mu\text{V}}$	C	D dB	VR mV	Unc ^F (k=2)
0	CW	X	0.0	0.0	1.0	0.00	178.7	$\pm 3.0 \%$
		Y	0.0	0.0	1.0		199.5	
		Z	0.0	0.0	1.0		186.5	
10010- CAA	SAR Validation (Square, 100ms, 10ms)	X	55.60	92.4	20.6	10.00	35.7	$\pm 1.7 \%$
		Y	2.80	61.2	11.6		42.9	
		Z	10.49	80.1	18.0		36.1	
10011- CAB	UMTS-FDD (WCDMA)	X	3.47	67.9	18.8	2.91	141.3	$\pm 0.7 \%$
		Y	3.29	67.0	18.4		138.2	
		Z	3.78	70.4	20.1		147.9	
10012- CAA	IEEE 802.11b WiFi 2.4 GHz (DSSS, 1 Mbps)	X	3.53	72.0	20.1	1.87	141.7	$\pm 0.7 \%$
		Y	3.03	69.1	18.8		141.1	
		Z	4.06	75.5	21.6		148.2	
10013- CAA	IEEE 802.11g WiFi 2.4 GHz (DSSS-OFDM, 6 Mbps)	X	10.87	69.8	22.6	9.46	137.3	$\pm 3.5 \%$
		Y	11.63	71.7	23.9		141.9	
		Z	10.51	69.6	22.5		139.2	
10021- DAB	GSM-FDD (TDMA, GMSK)	X	6.92	78.4	20.1	9.39	137.0	$\pm 2.5 \%$
		Y	26.20	99.6	27.8		141.5	
		Z	5.13	78.3	21.1		144.7	
10023- DAB	GPRS-FDD (TDMA, GMSK, TN 0)	X	9.10	83.6	22.5	9.57	144.0	$\pm 2.5 \%$
		Y	26.31	100.0	28.1		136.7	
		Z	6.15	81.6	22.5		139.9	
10024- DAB	GPRS-FDD (TDMA, GMSK, TN 0-1)	X	10.54	84.1	20.4	6.56	141.8	$\pm 2.5 \%$
		Y	40.55	99.6	24.9		142.2	
		Z	6.45	81.5	20.2		145.7	
10027- DAB	GPRS-FDD (TDMA, GMSK, TN 0-1-2)	X	28.34	94.6	21.9	4.80	131.4	$\pm 2.5 \%$
		Y	52.22	99.6	23.3		126.8	
		Z	28.33	99.5	23.9		140.7	
10028- DAB	GPRS-FDD (TDMA, GMSK, TN 0-1-2-3)	X	52.17	100.0	22.2	3.55	147.0	$\pm 1.7 \%$
		Y	57.29	99.6	22.4		133.0	
		Z	25.84	99.5	23.3		126.2	
10032- CAA	IEEE 802.15.1 Bluetooth (GFSK, DH5)	X	59.05	100.0	19.9	1.16	135.5	$\pm 1.9 \%$
		Y	100.00	99.7	19.2		143.5	
		Z	34.97	100.0	20.4		143.1	

10039-CAB	CDMA2000 (1xRTT, RC1)	X	4.78	66.9	18.9	4.57	134.6	±0.9 %
		Y	4.85	67.1	19.1		141.0	
		Z	4.76	67.8	19.4		140.7	
10081-CAB	CDMA2000 (1xRTT, RC3)	X	3.98	66.4	18.6	3.97	130.4	±0.7 %
		Y	3.98	66.5	18.7		136.2	
		Z	4.04	67.7	19.2		137.4	
10098-CAB	UMTS-FDD (HSUPA, Subtest 2)	X	4.75	67.3	18.8	3.98	144.4	±0.7 %
		Y	4.55	66.5	18.5		126.5	
		Z	4.72	67.9	19.0		128.1	
10100-CAB	LTE-FDD (SC-FDMA, 100% RB, 20 MHz, QPSK)	X	6.26	66.9	19.2	5.67	124.5	±1.2 %
		Y	6.38	67.4	19.7		131.7	
		Z	6.36	67.7	19.7		132.3	
10108-CAB	LTE-FDD (SC-FDMA, 100% RB, 10 MHz, QPSK)	X	6.44	67.5	19.7	5.80	147.4	±1.4 %
		Y	6.31	67.2	19.7		130.2	
		Z	6.17	67.2	19.6		130.1	
10110-CAB	LTE-FDD (SC-FDMA, 100% RB, 5 MHz, QPSK)	X	6.08	66.9	19.5	5.75	142.7	±1.4 %
		Y	5.97	66.6	19.4		127.3	
		Z	5.84	66.7	19.3		126.2	
10114-CAA	IEEE 802.11n (HT Greenfield, 13.5 Mbps, BPSK)	X	10.13	68.7	21.0	8.10	136.9	±2.5 %
		Y	10.57	69.9	21.9		146.3	
		Z	10.06	69.0	21.1		143.6	
10117-CAA	IEEE 802.11n (HT Mixed, 13.5 Mbps, BPSK)	X	10.12	68.6	21.0	8.07	138.2	±2.5 %
		Y	10.60	69.9	21.9		148.0	
		Z	10.07	69.0	21.1		146.6	
10151-CAB	LTE-TDD (SC-FDMA, 50% RB, 20 MHz, QPSK)	X	8.76	71.7	23.8	9.28	130.7	±3.0 %
		Y	10.03	75.2	25.9		121.5	
		Z	8.15	70.7	23.5		134.1	
10164-CAB	LTE-FDD (SC-FDMA, 50% RB, 10 MHz, QPSK)	X	6.10	67.0	19.5	5.75	144.4	±1.4 %
		Y	5.98	66.6	19.4		127.8	
		Z	5.84	66.6	19.3		127.2	
10160-CAB	LTE-FDD (SC-FDMA, 50% RB, 15 MHz, QPSK)	X	6.56	67.5	19.7	5.82	149.5	±1.7 %
		Y	6.41	67.1	19.6		132.5	
		Z	6.17	66.8	19.4		130.4	
10169-CAB	LTE-FDD (SC-FDMA, 1 RB, 20 MHz, QPSK)	X	5.01	67.0	19.7	5.73	147.8	±1.2 %
		Y	5.01	66.9	19.8		132.1	
		Z	4.75	66.9	19.7		130.3	
10172-CAB	LTE-TDD (SC-FDMA, 1 RB, 20 MHz, QPSK)	X	7.65	75.0	25.8	9.21	144.9	±2.7 %
		Y	10.17	82.4	29.7		136.4	
		Z	6.53	72.3	24.6		145.6	
10175-CAB	LTE-FDD (SC-FDMA, 1 RB, 10 MHz, QPSK)	X	4.98	66.9	19.6	5.72	141.0	±1.2 %
		Y	4.98	66.7	19.7		130.5	
		Z	4.71	66.7	19.5		128.1	

10181-CAB	LTE-FDD (SC-FDMA, 1 RB, 15 MHz, QPSK)	X	4.95	66.7	19.5	5.72	139.8	±1.2 %
		Y	4.97	66.7	19.7		129.5	
		Z	4.72	66.8	19.6		128.0	
10193-CAA	IEEE 802.11n (HT Greenfield, 6.5 Mbps, BPSK)	X	9.75	68.2	20.9	8.09	131.8	±2.5 %
		Y	10.16	69.4	21.7		139.2	
		Z	9.62	68.6	21.0		137.3	
10196-CAA	IEEE 802.11n (HT Mixed, 6.5 Mbps, BPSK)	X	9.77	68.3	20.9	8.10	133.6	±2.5 %
		Y	10.17	69.4	21.8		140.1	
		Z	9.61	68.5	21.0		140.1	
10219-CAA	IEEE 802.11n (HT Mixed, 7.2 Mbps, BPSK)	X	9.69	68.3	20.9	8.03	133.6	±2.5 %
		Y	10.05	69.3	21.7		139.2	
		Z	9.58	68.7	21.1		139.4	
10222-CAA	IEEE 802.11n (HT Mixed, 15 Mbps, BPSK)	X	10.13	68.7	21.0	8.06	140.7	±2.5 %
		Y	10.61	69.8	21.8		145.1	
		Z	10.11	69.1	21.2		148.4	
10225-CAB	UMTS-FDD (HSPA+)	X	7.03	67.2	19.4	5.97	138.0	±1.4 %
		Y	7.07	67.2	19.6		140.2	
		Z	6.97	67.8	19.7		144.6	
10237-CAB	LTE-TDD (SC-FDMA, 1 RB, 10 MHz, QPSK)	X	7.11	72.9	24.7	9.21	124.6	±2.7 %
		Y	10.04	82.0	29.5		135.7	
		Z	6.29	71.2	24.0		126.2	
10252-CAB	LTE-TDD (SC-FDMA, 50% RB, 10 MHz, QPSK)	X	8.61	72.5	24.3	9.24	145.2	±3.3 %
		Y	10.53	77.8	27.4		136.7	
		Z	7.56	70.0	23.1		126.7	
10267-CAB	LTE-TDD (SC-FDMA, 100% RB, 10 MHz, QPSK)	X	8.74	71.6	23.8	9.30	128.7	±3.3 %
		Y	11.51	79.1	28.0		147.2	
		Z	8.07	70.4	23.2		134.1	
10274-CAB	UMTS-FDD (HSUPA, Subtest 5, 3GPP Rel8.10)	X	5.90	66.7	18.7	4.87	128.0	±0.9 %
		Y	5.93	66.8	18.9		134.5	
		Z	5.92	67.6	19.1		138.2	
10275-CAB	UMTS-FDD (HSUPA, Subtest 5, 3GPP Rel8.4)	X	4.53	67.1	18.8	3.96	133.8	±0.7 %
		Y	4.48	67.0	18.8		139.6	
		Z	4.62	68.3	19.3		145.0	
10291-AAB	CDMA2000, RC3, SO55, Full Rate	X	3.82	67.8	19.0	3.46	147.6	±0.7 %
		Y	3.66	67.0	18.8		131.7	
		Z	3.97	69.6	20.0		135.9	
10292-AAB	CDMA2000, RC3, SO32, Full Rate	X	3.70	67.5	18.8	3.39	128.1	±0.7 %
		Y	3.60	66.9	18.7		132.5	
		Z	3.80	68.9	19.5		139.8	
10297-AAA	LTE-FDD (SC-FDMA, 50% RB, 20 MHz, QPSK)	X	6.47	67.6	19.8	5.81	149.7	±1.7 %
		Y	6.24	66.9	19.5		126.3	
		Z	6.20	67.3	19.6		130.9	

10311-AAA	LTE-FDD (SC-FDMA, 100% RB, 15 MHz, QPSK)	X	6.72	67.1	19.5	6.06	128.8	±1.4 %
		Y	6.85	67.7	20.0		132.4	
		Z	6.75	67.7	19.8		136.6	
10315-AAA	IEEE 802.11b WiFi 2.4 GHz (DSSS, 1 Mbps, 96pc duty cycle)	X	3.27	71.1	19.8	1.71	140.1	±0.7 %
		Y	2.95	69.4	19.1		139.8	
		Z	3.75	74.4	21.2		146.9	
10316-AAA	IEEE 802.11g WiFi 2.4 GHz (ERP-OFDM, 6 Mbps, 96pc duty cycle)	X	10.04	68.7	21.3	8.36	136.3	±2.5 %
		Y	10.42	69.8	22.1		138.1	
		Z	9.84	68.9	21.3		139.7	
10403-AAB	CDMA2000 (1xEV-DO, Rev. 0)	X	5.01	69.3	19.2	3.76	144.3	±0.7 %
		Y	4.79	68.1	18.7		146.3	
		Z	5.40	72.5	20.8		146.7	
10404-AAB	CDMA2000 (1xEV-DO, Rev. A)	X	4.97	69.5	19.3	3.77	141.3	±0.7 %
		Y	4.72	68.2	18.8		143.1	
		Z	5.12	71.8	20.5		144.4	
10415-AAA	IEEE 802.11b WiFi 2.4 GHz (DSSS, 1 Mbps, 99pc duty cycle)	X	3.05	70.5	19.5	1.54	139.7	±0.7 %
		Y	2.71	68.7	18.9		140.2	
		Z	4.22	77.3	22.5		145.9	
10416-AAA	IEEE 802.11g WiFi 2.4 GHz (ERP-OFDM, 6 Mbps, 99pc duty cycle)	X	9.92	68.6	21.1	8.23	136.3	±2.5 %
		Y	10.20	69.4	21.8		138.3	
		Z	9.76	68.8	21.3		138.9	

The reported uncertainty of measurement is stated as the standard uncertainty of measurement multiplied by the coverage factor $k=2$, which for a normal distribution corresponds to a coverage probability of approximately 95%.

^A The uncertainties of NormX,Y,Z do not affect the E²-field uncertainty inside TSL (see Pages 8 and 9).

^B Numerical linearization parameter: uncertainty not required.

^E Uncertainty is determined using the max. deviation from linear response applying rectangular distribution and is expressed for the square of the field value.

DASY/EASY - Parameters of Probe: ES3DV3 - SN:3332

Calibration Parameter Determined in Head Tissue Simulating Media

f (MHz) ^C	Relative Permittivity ^F	Conductivity (S/m) ^F	ConvF X	ConvF Y	ConvF Z	Alpha ^G	Depth ^G (mm)	Unct. (k=2)
750	41.9	0.89	6.56	6.56	6.56	0.50	1.43	± 12.0 %
835	41.5	0.90	6.31	6.31	6.31	0.61	1.31	± 12.0 %
1750	40.1	1.37	5.17	5.17	5.17	0.62	1.33	± 12.0 %
1900	40.0	1.40	5.04	5.04	5.04	0.80	1.17	± 12.0 %
2450	39.2	1.80	4.49	4.49	4.49	0.77	1.24	± 12.0 %
2600	39.0	1.96	4.35	4.35	4.35	0.73	1.38	± 12.0 %

^C Frequency validity above 300 MHz of ± 100 MHz only applies for DASY v4.4 and higher (see Page 2), else it is restricted to ± 50 MHz. The uncertainty is the RSS of the ConvF uncertainty at calibration frequency and the uncertainty for the indicated frequency band. Frequency validity below 300 MHz is ± 10, 25, 40, 50 and 70 MHz for ConvF assessments at 30, 64, 128, 150 and 220 MHz respectively. Above 5 GHz frequency validity can be extended to ± 110 MHz.

^F At frequencies below 3 GHz, the validity of tissue parameters (ϵ and σ) can be relaxed to ± 10% if liquid compensation formula is applied to measured SAR values. At frequencies above 3 GHz, the validity of tissue parameters (ϵ and σ) is restricted to ± 5%. The uncertainty is the RSS of the ConvF uncertainty for indicated target tissue parameters.

^G Alpha/Depth are determined during calibration. SPEAG warrants that the remaining deviation due to the boundary effect after compensation is always less than ± 1% for frequencies below 3 GHz and below ± 2% for frequencies between 3-6 GHz at any distance larger than half the probe tip diameter from the boundary.

DASY/EASY - Parameters of Probe: ES3DV3 - SN:3332

Calibration Parameter Determined in Body Tissue Simulating Media

f (MHz) ^c	Relative Permittivity ^F	Conductivity (S/m) ^F	ConvF X	ConvF Y	ConvF Z	Alpha ^g	Depth ^g (mm)	Unct. (k=2)
750	55.5	0.96	6.24	6.24	6.24	0.50	1.50	± 12.0 %
835	55.2	0.97	6.21	6.21	6.21	0.45	1.59	± 12.0 %
1750	53.4	1.49	4.88	4.88	4.88	0.39	1.78	± 12.0 %
1900	53.3	1.52	4.64	4.64	4.64	0.61	1.47	± 12.0 %
2450	52.7	1.95	4.31	4.31	4.31	0.80	1.18	± 12.0 %
2600	52.5	2.16	4.11	4.11	4.11	0.68	0.99	± 12.0 %

^c Frequency validity above 300 MHz of ± 100 MHz only applies for DASY v4.4 and higher (see Page 2), else it is restricted to ± 50 MHz. The uncertainty is the RSS of the ConvF uncertainty at calibration frequency and the uncertainty for the indicated frequency band. Frequency validity below 300 MHz is ± 10, 25, 40, 50 and 70 MHz for ConvF assessments at 30, 64, 128, 150 and 220 MHz respectively. Above 5 GHz frequency validity can be extended to ± 110 MHz.

^F At frequencies below 3 GHz, the validity of tissue parameters (ϵ and σ) can be relaxed to ± 10% if liquid compensation formula is applied to measured SAR values. At frequencies above 3 GHz, the validity of tissue parameters (ϵ and σ) is restricted to ± 5%. The uncertainty is the RSS of the ConvF uncertainty for indicated target tissue parameters.

^g Alpha/Depth are determined during calibration. SPEAG warrants that the remaining deviation due to the boundary effect after compensation is always less than ± 1% for frequencies below 3 GHz and below ± 2% for frequencies between 3-6 GHz at any distance larger than half the probe lip diameter from the boundary.

Frequency Response of E-Field (TEM-Cell:ifi110 EXX, Waveguide: R22)

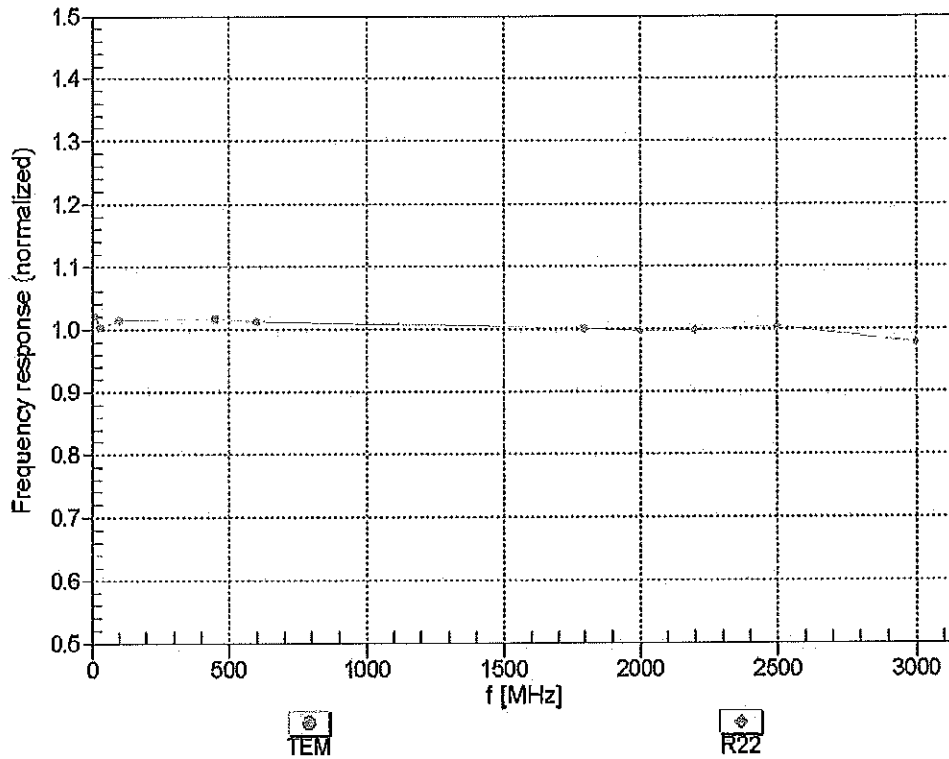

Uncertainty of Frequency Response of E-field: $\pm 6.3\%$ (k=2)

Receiving Pattern (ϕ), $\theta = 0^\circ$

f=600 MHz,TEM

f=1800 MHz,R22

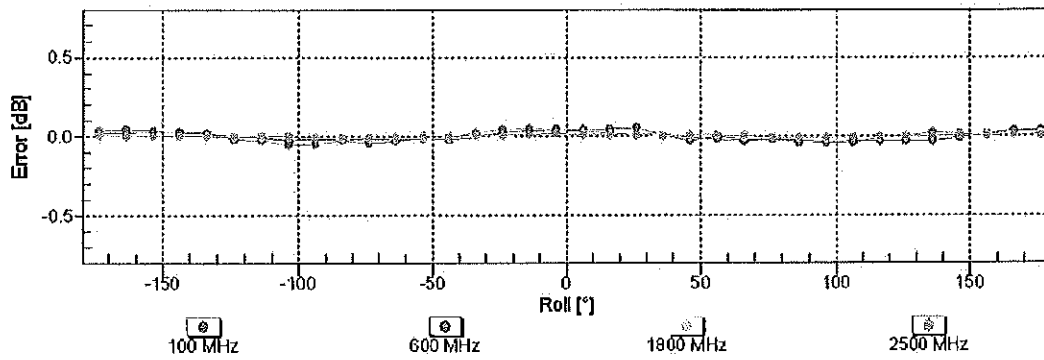
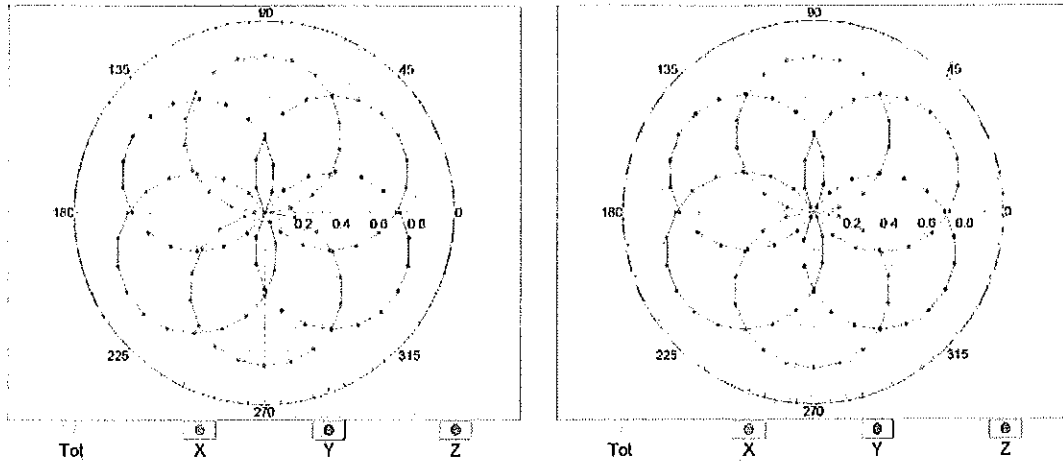

Uncertainty of Axial Isotropy Assessment: $\pm 0.5\%$ ($k=2$)

Dynamic Range $f(SAR_{head})$ (TEM cell , $f_{eval} = 1900$ MHz)

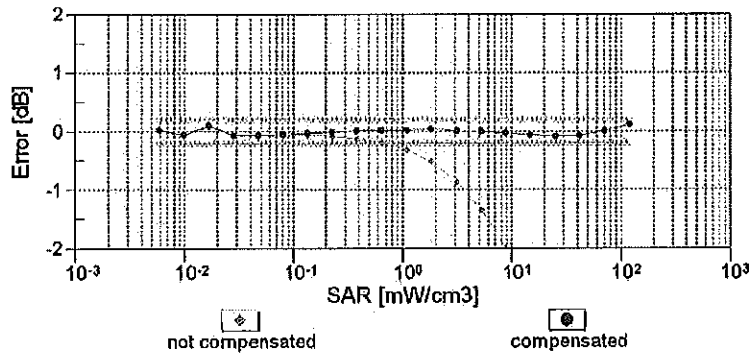
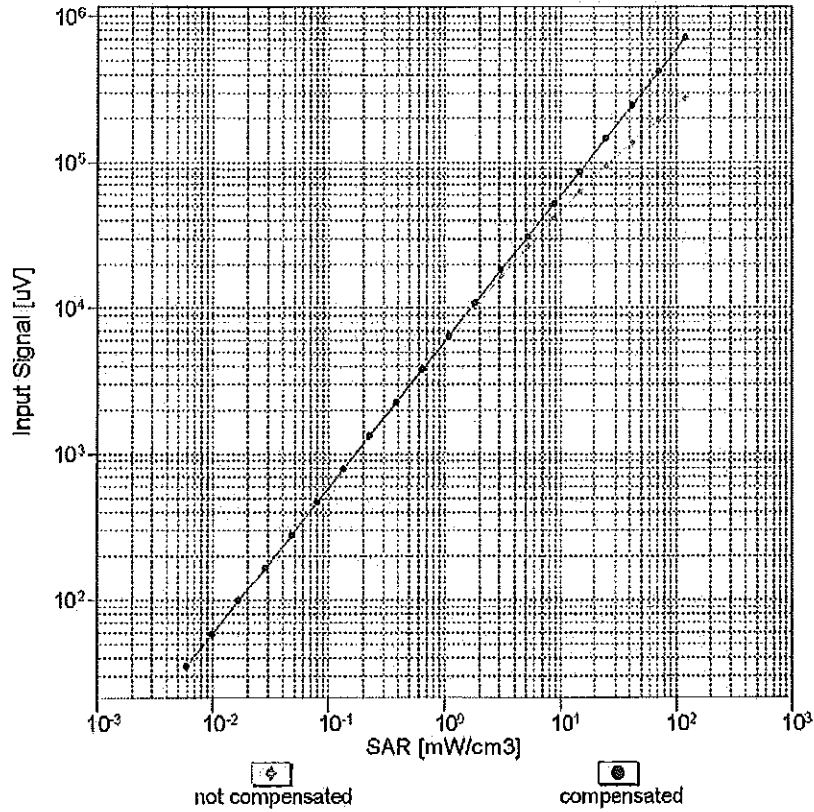

Uncertainty of Linearity Assessment: $\pm 0.6\%$ (k=2)

Conversion Factor Assessment

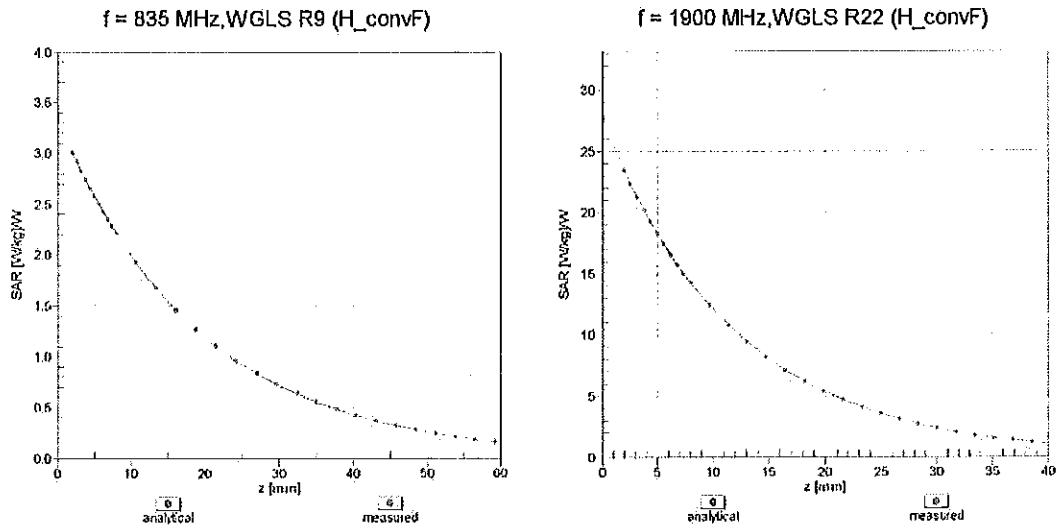

Deviation from Isotropy in Liquid Error (ϕ, θ), f = 900 MHz

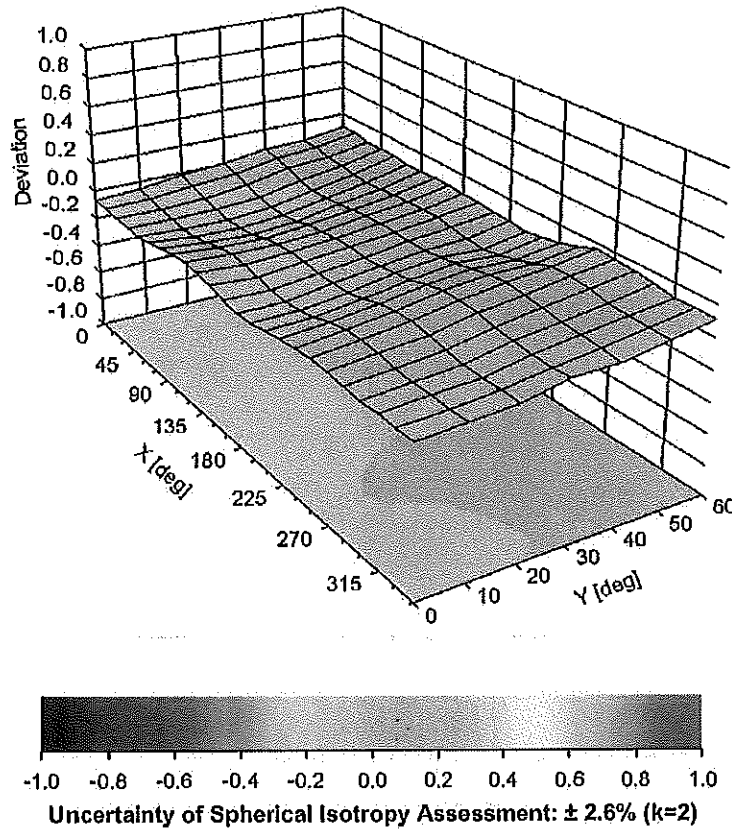

DASY/EASY - Parameters of Probe: ES3DV3 - SN:3332**Other Probe Parameters**

Sensor Arrangement	Triangular
Connector Angle (°)	-3.7
Mechanical Surface Detection Mode	enabled
Optical Surface Detection Mode	disabled
Probe Overall Length	337 mm
Probe Body Diameter	10 mm
Tip Length	10 mm
Tip Diameter	4 mm
Probe Tip to Sensor X Calibration Point	2 mm
Probe Tip to Sensor Y Calibration Point	2 mm
Probe Tip to Sensor Z Calibration Point	2 mm
Recommended Measurement Distance from Surface	3 mm



Accredited by the Swiss Accreditation Service (SAS)
The Swiss Accreditation Service is one of the signatories to the EA
Multilateral Agreement for the recognition of calibration certificates

Accreditation No.: **SCS 0108**

Client **PC Test**

Certificate No: **ES3-3213_Jan15**

CALIBRATION CERTIFICATE

Object	ES3DV3 - SN:3213
Calibration procedure(s)	QA CAL-01.v9, QA CAL-23.v5, QA CAL-25.v6 Calibration procedure for dosimetric E-field probes
Calibration date:	January 20, 2015

This calibration certificate documents the traceability to national standards, which realize the physical units of measurements (SI).
The measurements and the uncertainties with confidence probability are given on the following pages and are part of the certificate.

All calibrations have been conducted in the closed laboratory facility: environment temperature (22 ± 3)°C and humidity < 70%.

Calibration Equipment used (M&TE critical for calibration)

CC
1/30/15

Primary Standards	ID	Cal Date (Certificate No.)	Scheduled Calibration
Power meter E4419B	GB41293874	03-Apr-14 (No. 217-01911)	Apr-15
Power sensor E4412A	MY41498087	03-Apr-14 (No. 217-01911)	Apr-15
Reference 3 dB Attenuator	SN: S5054 (3c)	03-Apr-14 (No. 217-01915)	Apr-15
Reference 20 dB Attenuator	SN: S5277 (20x)	03-Apr-14 (No. 217-01919)	Apr-15
Reference 30 dB Attenuator	SN: S5129 (30b)	03-Apr-14 (No. 217-01920)	Apr-15
Reference Probe ES3DV2	SN: 3013	30-Dec-14 (No. ES3-3013_Dec14)	Dec-15
DAE4	SN: 660	14-Jan-15 (No. DAE4-660_Jan15)	Jan-16
Secondary Standards	ID	Check Date (in house)	Scheduled Check
RF generator HP 8648C	US3642U01700	4-Aug-99 (in house check Apr-13)	In house check: Apr-16
Network Analyzer HP 8753E	US37390585	18-Oct-01 (in house check Oct-14)	In house check: Oct-15

Calibrated by:	Name Israe Elnaouq	Function Laboratory Technician	Signature
Approved by:	Katja Pokovic	Technical Manager	

Issued: January 22, 2015

This calibration certificate shall not be reproduced except in full without written approval of the laboratory.



Accredited by the Swiss Accreditation Service (SAS)
The Swiss Accreditation Service is one of the signatories to the EA
Multilateral Agreement for the recognition of calibration certificates

Accreditation No.: **SCS 0108**

Glossary:

TSL	tissue simulating liquid
NORM _{x,y,z}	sensitivity in free space
ConvF	sensitivity in TSL / NORM _{x,y,z}
DCP	diode compression point
CF	crest factor (1/duty_cycle) of the RF signal
A, B, C, D	modulation dependent linearization parameters
Polarization φ	φ rotation around probe axis
Polarization ϑ	ϑ rotation around an axis that is in the plane normal to probe axis (at measurement center), i.e., ϑ = 0 is normal to probe axis
Connector Angle	information used in DASY system to align probe sensor X to the robot coordinate system

Calibration is Performed According to the Following Standards:

- a) IEEE Std 1528-2013, "IEEE Recommended Practice for Determining the Peak Spatial-Averaged Specific Absorption Rate (SAR) in the Human Head from Wireless Communications Devices: Measurement Techniques", June 2013
- b) IEC 62209-1, "Procedure to measure the Specific Absorption Rate (SAR) for hand-held devices used in close proximity to the ear (frequency range of 300 MHz to 3 GHz)", February 2005

Methods Applied and Interpretation of Parameters:

- *NORM_{x,y,z}*: Assessed for E-field polarization ϑ = 0 (f ≤ 900 MHz in TEM-cell; f > 1800 MHz: R22 waveguide). *NORM_{x,y,z}* are only intermediate values, i.e., the uncertainties of *NORM_{x,y,z}* does not affect the E²-field uncertainty inside TSL (see below *ConvF*).
- *NORM(f)_{x,y,z}* = *NORM_{x,y,z}* * *frequency_response* (see Frequency Response Chart). This linearization is implemented in DASY4 software versions later than 4.2. The uncertainty of the frequency response is included in the stated uncertainty of *ConvF*.
- *DCP_{x,y,z}*: DCP are numerical linearization parameters assessed based on the data of power sweep with CW signal (no uncertainty required). DCP does not depend on frequency nor media.
- *PAR*: PAR is the Peak to Average Ratio that is not calibrated but determined based on the signal characteristics
- *A_{x,y,z}*; *B_{x,y,z}*; *C_{x,y,z}*; *D_{x,y,z}*; *VR_{x,y,z}*; *A, B, C, D* are numerical linearization parameters assessed based on the data of power sweep for specific modulation signal. The parameters do not depend on frequency nor media. *VR* is the maximum calibration range expressed in RMS voltage across the diode.
- *ConvF* and *Boundary Effect Parameters*: Assessed in flat phantom using E-field (or Temperature Transfer Standard for f ≤ 800 MHz) and inside waveguide using analytical field distributions based on power measurements for f > 800 MHz. The same setups are used for assessment of the parameters applied for boundary compensation (alpha, depth) of which typical uncertainty values are given. These parameters are used in DASY4 software to improve probe accuracy close to the boundary. The sensitivity in TSL corresponds to *NORM_{x,y,z}* * *ConvF* whereby the uncertainty corresponds to that given for *ConvF*. A frequency dependent *ConvF* is used in DASY version 4.4 and higher which allows extending the validity from ± 50 MHz to ± 100 MHz.
- *Spherical isotropy (3D deviation from isotropy)*: in a field of low gradients realized using a flat phantom exposed by a patch antenna.
- *Sensor Offset*: The sensor offset corresponds to the offset of virtual measurement center from the probe tip (on probe axis). No tolerance required.
- *Connector Angle*: The angle is assessed using the information gained by determining the *NORM_x* (no uncertainty required).

Probe ES3DV3

SN:3213

Manufactured: October 14, 2008
Calibrated: January 20, 2015

Calibrated for DASY/EASY Systems
(Note: non-compatible with DASY2 system!)

DASY/EASY - Parameters of Probe: ES3DV3 - SN:3213

Basic Calibration Parameters

	Sensor X	Sensor Y	Sensor Z	Unc (k=2)
Norm ($\mu V/(V/m)^2$) ^A	1.49	1.37	1.34	$\pm 10.1\%$
DCP (mV) ^B	99.9	101.8	101.4	

Modulation Calibration Parameters

UID	Communication System Name		A dB	B dB $\sqrt{\mu V}$	C	D dB	VR mV	Unc ^E (k=2)
0	CW	X	0.0	0.0	1.0	0.00	169.8	$\pm 3.8\%$
		Y	0.0	0.0	1.0		215.4	
		Z	0.0	0.0	1.0		214.5	
10010-CAA	SAR Validation (Square, 100ms, 10ms)	X	1.84	57.8	10.2	10.00	47.4	$\pm 1.9\%$
		Y	1.82	58.6	10.3		44.3	
		Z	1.65	57.3	9.2		44.2	
10011-CAB	UMTS-FDD (WCDMA)	X	3.32	66.8	18.5	2.91	135.8	$\pm 0.5\%$
		Y	3.18	66.4	18.2		127.9	
		Z	3.21	66.5	18.2		128.1	
10012-CAB	IEEE 802.11b WiFi 2.4 GHz (DSSS, 1 Mbps)	X	2.90	68.1	18.4	1.87	137.2	$\pm 0.7\%$
		Y	2.97	69.2	19.0		130.1	
		Z	2.80	68.0	18.4		129.9	
10013-CAB	IEEE 802.11g WiFi 2.4 GHz (DSSS-OFDM, 6 Mbps)	X	11.40	71.2	23.7	9.46	135.1	$\pm 3.8\%$
		Y	11.25	71.3	23.9		124.2	
		Z	10.96	70.3	23.2		124.8	
10021-DAB	GSM-FDD (TDMA, GMSK)	X	18.25	96.6	27.2	9.39	140.4	$\pm 1.7\%$
		Y	21.48	99.9	28.2		133.3	
		Z	11.76	89.4	24.5		127.3	
10023-DAB	GPRS-FDD (TDMA, GMSK, TN 0)	X	13.12	91.7	26.0	9.57	126.4	$\pm 1.9\%$
		Y	17.05	95.2	26.6		127.3	
		Z	8.91	85.2	23.3		118.8	
10024-DAB	GPRS-FDD (TDMA, GMSK, TN 0-1)	X	34.78	100.0	25.2	6.56	116.4	$\pm 1.7\%$
		Y	33.37	99.5	24.8		111.7	
		Z	34.11	99.5	24.6		110.5	
10027-DAB	GPRS-FDD (TDMA, GMSK, TN 0-1-2)	X	37.18	99.7	24.0	4.80	131.2	$\pm 1.7\%$
		Y	44.91	99.8	23.3		127.4	
		Z	41.51	99.7	23.2		125.0	
10028-DAB	GPRS-FDD (TDMA, GMSK, TN 0-1-2-3)	X	48.95	99.5	22.4	3.55	140.9	$\pm 1.7\%$
		Y	67.41	99.8	21.5		137.8	
		Z	56.45	100.0	21.9		135.0	
10032-CAA	IEEE 802.15.1 Bluetooth (GFSK, DH5)	X	20.23	99.3	22.1	1.16	111.3	$\pm 1.2\%$
		Y	32.72	99.5	20.6		109.6	
		Z	48.57	100.0	20.0		108.8	
10100-CAB	LTE-FDD (SC-FDMA, 100% RB, 20 MHz, QPSK)	X	6.60	67.9	20.0	5.67	144.6	$\pm 1.2\%$
		Y	6.55	68.2	20.2		142.7	
		Z	6.50	67.8	19.9		141.5	

10103-CAB	LTE-TDD (SC-FDMA, 100% RB, 20 MHz, QPSK)	X	10.34	75.7	26.2	9.29	133.2	±2.5 %
		Y	10.31	76.5	26.9		128.2	
		Z	9.74	74.5	25.6		127.1	
10108-CAC	LTE-FDD (SC-FDMA, 100% RB, 10 MHz, QPSK)	X	6.50	67.6	20.0	5.80	142.8	±1.2 %
		Y	6.41	67.7	20.1		140.3	
		Z	6.41	67.6	19.9		140.2	
10117-CAB	IEEE 802.11n (HT Mixed, 13.5 Mbps, BPSK)	X	10.36	69.2	21.6	8.07	132.8	±2.7 %
		Y	10.42	69.7	21.9		131.4	
		Z	10.22	69.1	21.4		130.0	
10151-CAB	LTE-TDD (SC-FDMA, 50% RB, 20 MHz, QPSK)	X	9.65	74.6	25.8	9.28	127.9	±2.5 %
		Y	9.66	75.6	26.7		123.7	
		Z	9.14	73.6	25.3		122.7	
10154-CAC	LTE-FDD (SC-FDMA, 50% RB, 10 MHz, QPSK)	X	6.14	66.9	19.6	5.75	139.3	±1.4 %
		Y	6.08	67.2	19.9		138.5	
		Z	6.05	66.9	19.6		137.3	
10160-CAB	LTE-FDD (SC-FDMA, 50% RB, 15 MHz, QPSK)	X	6.58	67.5	19.9	5.82	144.3	±1.4 %
		Y	6.54	67.8	20.1		143.7	
		Z	6.50	67.5	19.8		142.1	
10169-CAB	LTE-FDD (SC-FDMA, 1 RB, 20 MHz, QPSK)	X	4.93	66.1	19.3	5.73	120.6	±0.9 %
		Y	4.93	66.7	19.8		120.9	
		Z	4.85	66.3	19.5		118.9	
10172-CAB	LTE-TDD (SC-FDMA, 1 RB, 20 MHz, QPSK)	X	8.93	79.5	28.6	9.21	140.8	±2.5 %
		Y	9.60	82.9	30.6		139.9	
		Z	8.30	78.2	27.9		136.6	
10175-CAC	LTE-FDD (SC-FDMA, 1 RB, 10 MHz, QPSK)	X	4.90	66.0	19.3	5.72	118.8	±0.9 %
		Y	4.93	66.8	19.8		120.2	
		Z	4.81	66.1	19.3		116.6	
10181-CAB	LTE-FDD (SC-FDMA, 1 RB, 15 MHz, QPSK)	X	4.92	66.1	19.3	5.72	119.0	±0.9 %
		Y	4.92	66.6	19.8		120.5	
		Z	4.77	65.8	19.2		115.8	
10196-CAB	IEEE 802.11n (HT Mixed, 6.5 Mbps, BPSK)	X	9.93	68.7	21.4	8.10	125.0	±2.5 %
		Y	10.06	69.4	21.9		128.3	
		Z	9.78	68.5	21.2		120.5	
10225-CAB	UMTS-FDD (HSPA+)	X	6.66	65.7	18.8	5.97	106.5	±0.9 %
		Y	6.81	66.6	19.3		112.3	
		Z	6.64	66.0	18.9		108.0	
10237-CAB	LTE-TDD (SC-FDMA, 1 RB, 10 MHz, QPSK)	X	8.91	79.4	28.5	9.21	141.4	±2.2 %
		Y	9.39	82.3	30.4		146.7	
		Z	8.40	78.5	28.2		141.2	
10252-CAB	LTE-TDD (SC-FDMA, 50% RB, 10 MHz, QPSK)	X	8.84	73.3	25.2	9.24	119.1	±2.7 %
		Y	8.94	74.6	26.3		118.6	
		Z	8.39	72.4	24.7		114.0	
10267-CAB	LTE-TDD (SC-FDMA, 100% RB, 10 MHz, QPSK)	X	9.62	74.6	25.8	9.30	126.2	±2.7 %
		Y	9.77	76.0	26.9		126.1	
		Z	9.10	73.4	25.2		121.4	

10275-CAB	UMTS-FDD (HSUPA, Subtest 5, 3GPP Rel8.4)	X	4.43	66.4	18.5	3.96	132.5	±0.7 %
		Y	4.37	66.6	18.6		134.1	
		Z	4.40	66.7	18.6		130.5	
10291-AAB	CDMA2000, RC3, SO55, Full Rate	X	3.63	66.4	18.4	3.46	122.5	±0.5 %
		Y	3.54	66.5	18.5		124.9	
		Z	3.55	66.3	18.3		121.4	
10292-AAB	CDMA2000, RC3, SO32, Full Rate	X	3.49	65.9	18.1	3.39	125.1	±0.5 %
		Y	3.52	66.7	18.6		126.1	
		Z	3.51	66.5	18.4		123.8	
10297-AAA	LTE-FDD (SC-FDMA, 50% RB, 20 MHz, QPSK)	X	6.49	67.6	19.9	5.81	143.1	±1.4 %
		Y	6.49	68.0	20.3		142.3	
		Z	6.42	67.6	19.9		144.3	
10311-AAA	LTE-FDD (SC-FDMA, 100% RB, 15 MHz, QPSK)	X	7.06	68.1	20.2	6.06	147.6	±1.7 %
		Y	7.09	68.7	20.7		148.2	
		Z	7.03	68.3	20.4		149.8	
10403-AAB	CDMA2000 (1xEV-DO, Rev. 0)	X	4.66	67.4	18.4	3.76	135.3	±0.5 %
		Y	4.69	68.1	18.7		134.9	
		Z	4.72	68.2	18.7		136.5	
10404-AAB	CDMA2000 (1xEV-DO, Rev. A)	X	4.58	67.4	18.3	3.77	133.4	±0.5 %
		Y	4.68	68.4	18.9		132.8	
		Z	4.58	67.9	18.5		135.4	
10415-AAA	IEEE 802.11b WiFi 2.4 GHz (DSSS, 1 Mbps, 99pc duty cycle)	X	2.41	65.7	17.2	1.54	131.4	±0.7 %
		Y	2.42	66.4	17.7		131.3	
		Z	2.59	67.7	18.2		134.1	
10416-AAA	IEEE 802.11g WiFi 2.4 GHz (ERP-OFDM, 6 Mbps, 99pc duty cycle)	X	10.06	68.9	21.5	8.23	127.6	±2.7 %
		Y	10.12	69.5	22.0		126.3	
		Z	10.04	69.1	21.7		129.7	

The reported uncertainty of measurement is stated as the standard uncertainty of measurement multiplied by the coverage factor $k=2$, which for a normal distribution corresponds to a coverage probability of approximately 95%.

^A The uncertainties of NormX,Y,Z do not affect the E^2 -field uncertainty inside TSL (see Pages 7 and 8).

^B Numerical linearization parameter: uncertainty not required.

^E Uncertainty is determined using the max. deviation from linear response applying rectangular distribution and is expressed for the square of the field value.

DASY/EASY - Parameters of Probe: ES3DV3 - SN:3213

Calibration Parameter Determined in Head Tissue Simulating Media

f (MHz) ^c	Relative Permittivity ^F	Conductivity (S/m) ^F	ConvF X	ConvF Y	ConvF Z	Alpha ^G	Depth ^G (mm)	Unct. (k=2)
750	41.9	0.89	6.45	6.45	6.45	0.57	1.37	± 12.0 %
835	41.5	0.90	6.26	6.26	6.26	0.65	1.26	± 12.0 %
1750	40.1	1.37	5.22	5.22	5.22	0.47	1.47	± 12.0 %
1900	40.0	1.40	5.06	5.06	5.06	0.80	1.14	± 12.0 %
2450	39.2	1.80	4.54	4.54	4.54	0.78	1.22	± 12.0 %
2600	39.0	1.96	4.33	4.33	4.33	0.80	1.28	± 12.0 %

^c Frequency validity above 300 MHz of ± 100 MHz only applies for DASY v4.4 and higher (see Page 2), else it is restricted to ± 50 MHz. The uncertainty is the RSS of the ConvF uncertainty at calibration frequency and the uncertainty for the indicated frequency band. Frequency validity below 300 MHz is ± 10, 25, 40, 50 and 70 MHz for ConvF assessments at 30, 64, 128, 150 and 220 MHz respectively. Above 5 GHz frequency validity can be extended to ± 110 MHz.

^F At frequencies below 3 GHz, the validity of tissue parameters (ϵ and σ) can be relaxed to ± 10% if liquid compensation formula is applied to measured SAR values. At frequencies above 3 GHz, the validity of tissue parameters (ϵ and σ) is restricted to ± 5%. The uncertainty is the RSS of the ConvF uncertainty for indicated target tissue parameters.

^G Alpha/Depth are determined during calibration. SPEAG warrants that the remaining deviation due to the boundary effect after compensation is always less than ± 1% for frequencies below 3 GHz and below ± 2% for frequencies between 3-6 GHz at any distance larger than half the probe tip diameter from the boundary.

DASY/EASY - Parameters of Probe: ES3DV3 - SN:3213

Calibration Parameter Determined in Body Tissue Simulating Media

f (MHz) ^C	Relative Permittivity ^F	Conductivity (S/m) ^F	ConvF X	ConvF Y	ConvF Z	Alpha ^G	Depth ^G (mm)	Unct. (k=2)
750	55.5	0.96	6.11	6.11	6.11	0.71	1.24	± 12.0 %
835	55.2	0.97	6.07	6.07	6.07	0.35	1.86	± 12.0 %
1750	53.4	1.49	4.93	4.93	4.93	0.51	1.47	± 12.0 %
1900	53.3	1.52	4.72	4.72	4.72	0.80	1.20	± 12.0 %
2450	52.7	1.95	4.37	4.37	4.37	0.71	1.12	± 12.0 %
2600	52.5	2.16	4.20	4.20	4.20	0.66	0.95	± 12.0 %

^C Frequency validity above 300 MHz of ± 100 MHz only applies for DASY v4.4 and higher (see Page 2), else it is restricted to ± 50 MHz. The uncertainty is the RSS of the ConvF uncertainty at calibration frequency and the uncertainty for the indicated frequency band. Frequency validity below 300 MHz is ± 10, 25, 40, 50 and 70 MHz for ConvF assessments at 30, 64, 128, 150 and 220 MHz respectively. Above 5 GHz frequency validity can be extended to ± 110 MHz.

^F At frequencies below 3 GHz, the validity of tissue parameters (ϵ and σ) can be relaxed to ± 10% if liquid compensation formula is applied to measured SAR values. At frequencies above 3 GHz, the validity of tissue parameters (ϵ and σ) is restricted to ± 5%. The uncertainty is the RSS of the ConvF uncertainty for indicated target tissue parameters.

^G Alpha/Depth are determined during calibration. SPEAG warrants that the remaining deviation due to the boundary effect after compensation is always less than ± 1% for frequencies below 3 GHz and below ± 2% for frequencies between 3-6 GHz at any distance larger than half the probe tip diameter from the boundary.

Frequency Response of E-Field (TEM-Cell:ifi110 EXX, Waveguide: R22)

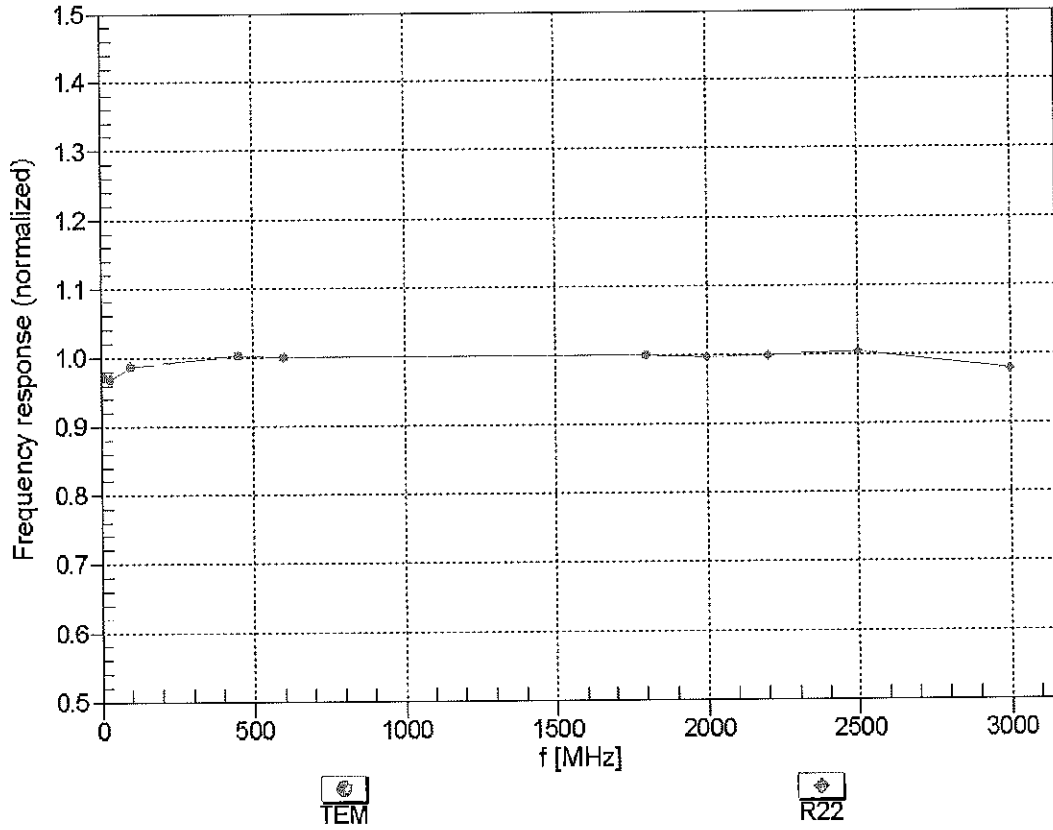

Uncertainty of Frequency Response of E-field: $\pm 6.3\%$ (k=2)

Receiving Pattern (ϕ), $\theta = 0^\circ$

f=600 MHz, TEM

f=1800 MHz, R22

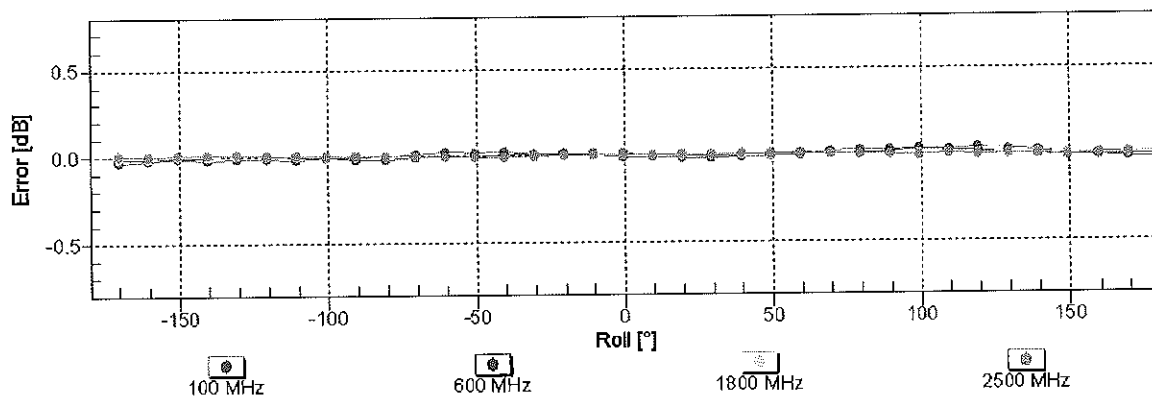
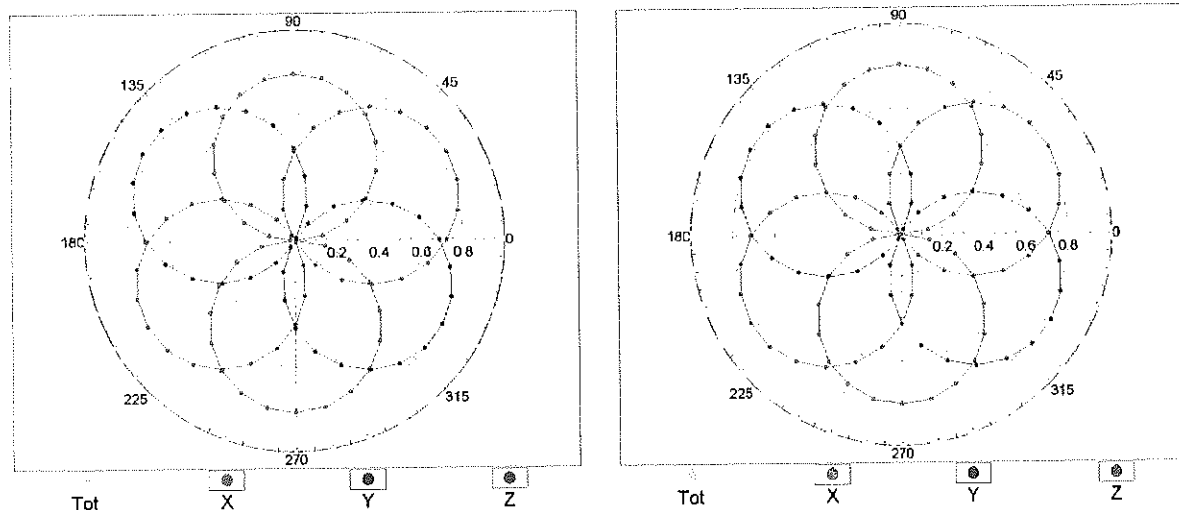

Uncertainty of Axial Isotropy Assessment: $\pm 0.5\%$ (k=2)

Dynamic Range $f(SAR_{head})$ (TEM cell , $f_{eval}= 1900$ MHz)

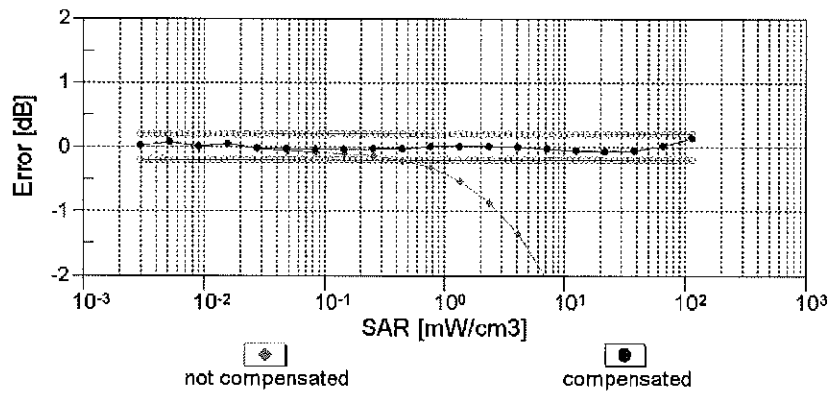
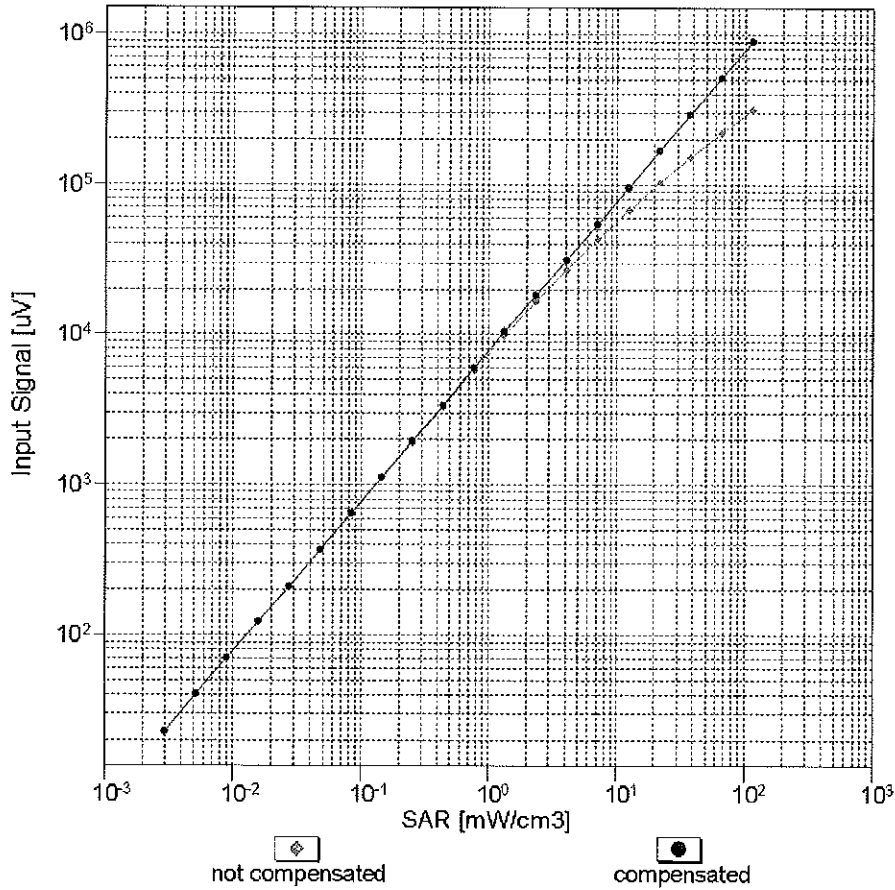

Uncertainty of Linearity Assessment: ± 0.6% (k=2)

Conversion Factor Assessment

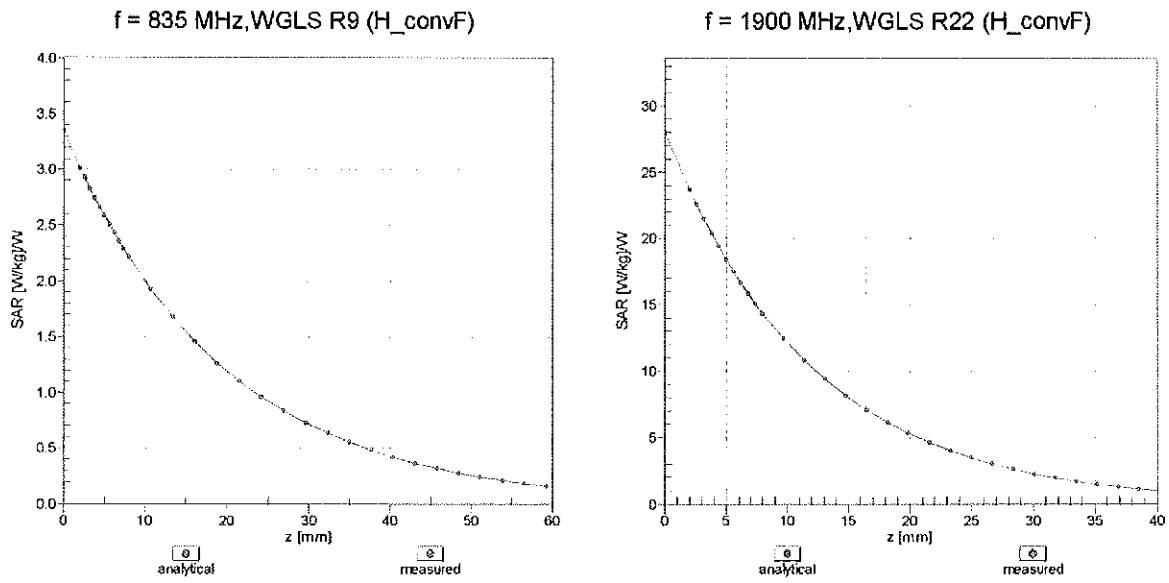

Deviation from Isotropy in Liquid Error (ϕ, θ), f = 900 MHz

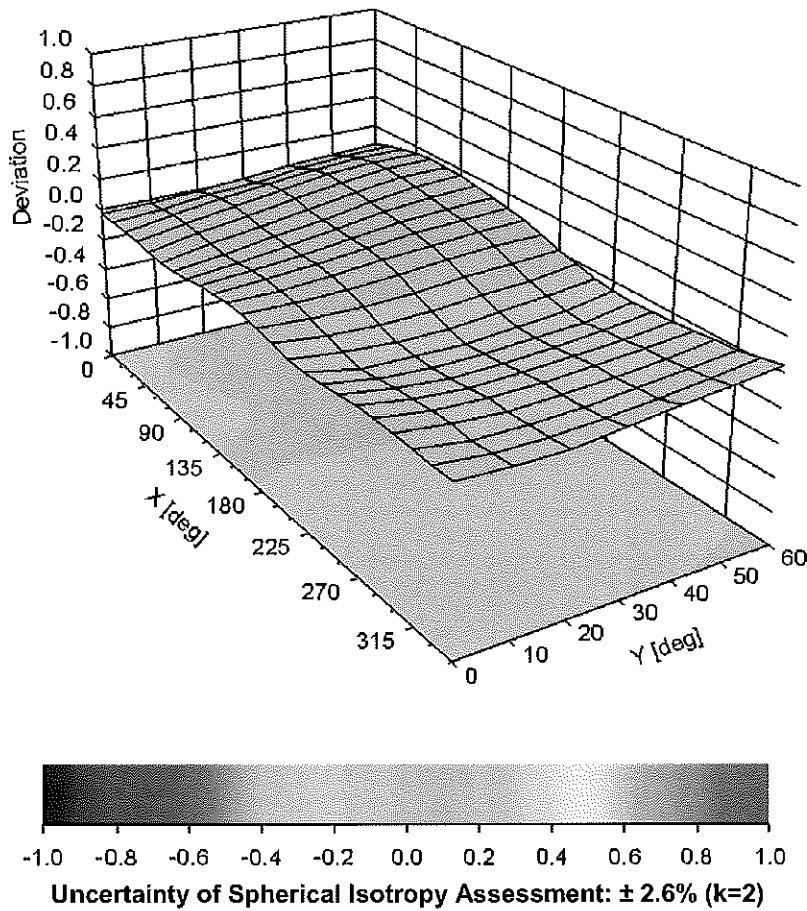

DASY/EASY - Parameters of Probe: ES3DV3 - SN:3213**Other Probe Parameters**

Sensor Arrangement	Triangular
Connector Angle (°)	-70.6
Mechanical Surface Detection Mode	enabled
Optical Surface Detection Mode	disabled
Probe Overall Length	337 mm
Probe Body Diameter	10 mm
Tip Length	10 mm
Tip Diameter	4 mm
Probe Tip to Sensor X Calibration Point	2 mm
Probe Tip to Sensor Y Calibration Point	2 mm
Probe Tip to Sensor Z Calibration Point	2 mm
Recommended Measurement Distance from Surface	3 mm



Accredited by the Swiss Accreditation Service (SAS)
The Swiss Accreditation Service is one of the signatories to the EA
Multilateral Agreement for the recognition of calibration certificates

Accreditation No.: **SCS 0108**

Client **PC Test**

Certificate No: **EX3-3914_Feb15**

CALIBRATION CERTIFICATE

Object **EX3DV4 - SN:3914** CCV
3/6/15

Calibration procedure(s) **QA CAL-01.v9, QA CAL-14.v4, QA CAL-23.v5, QA CAL-25.v6
Calibration procedure for dosimetric E-field probes**

Calibration date: **February 10, 2015**

This calibration certificate documents the traceability to national standards, which realize the physical units of measurements (SI).
The measurements and the uncertainties with confidence probability are given on the following pages and are part of the certificate.

All calibrations have been conducted in the closed laboratory facility: environment temperature (22 ± 3)°C and humidity < 70%.

Calibration Equipment used (M&TE critical for calibration)

Primary Standards	ID	Cal Date (Certificate No.)	Scheduled Calibration
Power meter E4419B	GB41293874	03-Apr-14 (No. 217-01911)	Apr-15
Power sensor E4412A	MY41498087	03-Apr-14 (No. 217-01911)	Apr-15
Reference 3 dB Attenuator	SN: S5054 (3c)	03-Apr-14 (No. 217-01915)	Apr-15
Reference 20 dB Attenuator	SN: S5277 (20x)	03-Apr-14 (No. 217-01919)	Apr-15
Reference 30 dB Attenuator	SN: S5129 (30b)	03-Apr-14 (No. 217-01920)	Apr-15
Reference Probe ES3DV2	SN: 3013	30-Dec-14 (No. ES3-3013_Dec14)	Dec-15
DAE4	SN: 660	14-Jan-15 (No. DAE4-660_Jan15)	Jan-16
Secondary Standards	ID	Check Date (in house)	Scheduled Check
RF generator HP 8648C	US3642U01700	4-Aug-99 (in house check Apr-13)	In house check: Apr-16
Network Analyzer HP 8753E	US37390585	18-Oct-01 (in house check Oct-14)	In house check: Oct-15

Calibrated by:	Name Claudio Leubler	Function Laboratory Technician	Signature
Approved by:	Name Katja Pokovic	Function Technical Manager	

Issued: February 10, 2015

This calibration certificate shall not be reproduced except in full without written approval of the laboratory.



Accredited by the Swiss Accreditation Service (SAS)

Accreditation No.: **SCS 0108**

The Swiss Accreditation Service is one of the signatories to the EA Multilateral Agreement for the recognition of calibration certificates

Glossary:

TSL	tissue simulating liquid
NORM _{x,y,z}	sensitivity in free space
ConvF	sensitivity in TSL / NORM _{x,y,z}
DCP	diode compression point
CF	crest factor (1/duty_cycle) of the RF signal
A, B, C, D	modulation dependent linearization parameters
Polarization φ	φ rotation around probe axis
Polarization ϑ	ϑ rotation around an axis that is in the plane normal to probe axis (at measurement center), i.e., $\vartheta = 0$ is normal to probe axis
Connector Angle	information used in DASY system to align probe sensor X to the robot coordinate system

Calibration is Performed According to the Following Standards:

- a) IEEE Std 1528-2013, "IEEE Recommended Practice for Determining the Peak Spatial-Averaged Specific Absorption Rate (SAR) in the Human Head from Wireless Communications Devices: Measurement Techniques", June 2013
- b) IEC 62209-1, "Procedure to measure the Specific Absorption Rate (SAR) for hand-held devices used in close proximity to the ear (frequency range of 300 MHz to 3 GHz)", February 2005

Methods Applied and Interpretation of Parameters:

- *NORM_{x,y,z}*: Assessed for E-field polarization $\vartheta = 0$ ($f \leq 900$ MHz in TEM-cell; $f > 1800$ MHz: R22 waveguide). *NORM_{x,y,z}* are only intermediate values, i.e., the uncertainties of *NORM_{x,y,z}* does not affect the E^2 -field uncertainty inside TSL (see below *ConvF*).
- *NORM(f)_{x,y,z}* = *NORM_{x,y,z}* * *frequency_response* (see Frequency Response Chart). This linearization is implemented in DASY4 software versions later than 4.2. The uncertainty of the frequency response is included in the stated uncertainty of *ConvF*.
- *DCP_{x,y,z}*: DCP are numerical linearization parameters assessed based on the data of power sweep with CW signal (no uncertainty required). DCP does not depend on frequency nor media.
- *PAR*: PAR is the Peak to Average Ratio that is not calibrated but determined based on the signal characteristics
- *A_{x,y,z}; B_{x,y,z}; C_{x,y,z}; D_{x,y,z}; VR_{x,y,z}; A, B, C, D* are numerical linearization parameters assessed based on the data of power sweep for specific modulation signal. The parameters do not depend on frequency nor media. *VR* is the maximum calibration range expressed in RMS voltage across the diode.
- *ConvF and Boundary Effect Parameters*: Assessed in flat phantom using E-field (or Temperature Transfer Standard for $f \leq 800$ MHz) and inside waveguide using analytical field distributions based on power measurements for $f > 800$ MHz. The same setups are used for assessment of the parameters applied for boundary compensation (alpha, depth) of which typical uncertainty values are given. These parameters are used in DASY4 software to improve probe accuracy close to the boundary. The sensitivity in TSL corresponds to *NORM_{x,y,z}* * *ConvF* whereby the uncertainty corresponds to that given for *ConvF*. A frequency dependent *ConvF* is used in DASY version 4.4 and higher which allows extending the validity from ± 50 MHz to ± 100 MHz.
- *Spherical isotropy (3D deviation from isotropy)*: in a field of low gradients realized using a flat phantom exposed by a patch antenna.
- *Sensor Offset*: The sensor offset corresponds to the offset of virtual measurement center from the probe tip (on probe axis). No tolerance required.
- *Connector Angle*: The angle is assessed using the information gained by determining the *NORM_x* (no uncertainty required).

Probe EX3DV4

SN:3914

Manufactured:	December 18, 2012
Repaired:	January 23, 2015
Calibrated:	February 10, 2015

Calibrated for DASY/EASY Systems
(Note: non-compatible with DASY2 system!)

DASY/EASY - Parameters of Probe: EX3DV4 - SN:3914

Basic Calibration Parameters

	Sensor X	Sensor Y	Sensor Z	Unc (k=2)
Norm ($\mu\text{V}/(\text{V}/\text{m})^2$) ^A	0.48	0.42	0.45	$\pm 10.1\%$
DCP (mV) ^B	102.7	103.2	101.3	

Modulation Calibration Parameters

UID	Communication System Name		A dB	B dB $\sqrt{\mu\text{V}}$	C	D dB	VR mV	Unc ^E (k=2)
0	CW	X	0.0	0.0	1.0	0.00	137.3	$\pm 2.7\%$
		Y	0.0	0.0	1.0		140.8	
		Z	0.0	0.0	1.0		134.6	
10010- CAA	SAR Validation (Square, 100ms, 10ms)	X	1.33	60.3	9.9	10.00	40.4	$\pm 1.2\%$
		Y	1.02	57.7	9.2		42.2	
		Z	1.41	61.3	11.0		39.9	
10011- CAB	UMTS-FDD (WCDMA)	X	3.39	67.3	18.6	2.91	148.9	$\pm 0.5\%$
		Y	3.47	67.6	18.6		130.1	
		Z	3.30	66.5	17.9		145.8	
10012- CAB	IEEE 802.11b WiFi 2.4 GHz (DSSS, 1 Mbps)	X	2.92	68.9	18.9	1.87	149.0	$\pm 0.7\%$
		Y	3.17	70.1	19.2		131.4	
		Z	2.72	67.0	17.6		146.9	
10013- CAB	IEEE 802.11g WiFi 2.4 GHz (DSSS-OFDM, 6 Mbps)	X	10.52	69.1	22.1	9.46	140.7	$\pm 3.3\%$
		Y	10.67	69.8	22.6		146.8	
		Z	10.44	68.9	22.0		136.8	
10021- DAB	GSM-FDD (TDMA, GMSK)	X	1.64	63.4	11.8	9.39	86.2	$\pm 1.7\%$
		Y	2.03	65.7	13.6		105.2	
		Z	1.78	63.6	12.4		85.9	
10023- DAB	GPRS-FDD (TDMA, GMSK, TN 0)	X	1.78	65.0	13.2	9.57	84.0	$\pm 2.2\%$
		Y	1.84	63.8	12.5		101.1	
		Z	1.92	64.9	13.4		83.0	
10024- DAB	GPRS-FDD (TDMA, GMSK, TN 0-1)	X	2.04	68.8	13.2	6.56	141.3	$\pm 1.9\%$
		Y	2.32	70.4	14.4		134.7	
		Z	1.59	65.5	12.3		139.3	
10027- DAB	GPRS-FDD (TDMA, GMSK, TN 0-1-2)	X	1.51	67.3	11.9	4.80	148.8	$\pm 1.9\%$
		Y	1.27	63.7	10.0		136.2	
		Z	3.26	75.5	15.4		148.7	
10028- DAB	GPRS-FDD (TDMA, GMSK, TN 0-1-2-3)	X	52.54	99.9	20.2	3.55	143.3	$\pm 1.7\%$
		Y	2.95	74.0	13.7		149.7	
		Z	32.98	99.9	21.5		141.9	
10032- CAA	IEEE 802.15.1 Bluetooth (GFSK, DH5)	X	96.97	99.5	17.5	1.16	145.3	$\pm 1.2\%$
		Y	83.69	99.7	18.1		128.6	
		Z	0.69	65.4	9.0		143.2	

10062-CAB	IEEE 802.11a/h WiFi 5 GHz (OFDM, 6 Mbps)	X	10.27	68.9	21.5	8.68	145.1	±2.7 %
		Y	9.95	68.4	21.3		123.8	
		Z	10.18	68.8	21.4		140.9	
10100-CAB	LTE-FDD (SC-FDMA, 100% RB, 20 MHz, QPSK)	X	6.38	67.0	19.3	5.67	140.1	±1.4 %
		Y	6.54	67.7	19.6		147.0	
		Z	6.34	66.8	19.1		137.4	
10103-CAB	LTE-TDD (SC-FDMA, 100% RB, 20 MHz, QPSK)	X	7.44	67.6	21.6	9.29	132.4	±1.7 %
		Y	7.78	69.0	22.4		140.2	
		Z	7.40	67.4	21.4		129.5	
10108-CAC	LTE-FDD (SC-FDMA, 100% RB, 10 MHz, QPSK)	X	6.25	66.7	19.2	5.80	137.9	±1.4 %
		Y	6.36	67.2	19.5		143.3	
		Z	6.20	66.4	19.0		135.0	
10117-CAB	IEEE 802.11n (HT Mixed, 13.5 Mbps, BPSK)	X	10.03	68.2	20.7	8.07	128.5	±2.5 %
		Y	10.17	68.7	21.0		134.9	
		Z	9.94	68.0	20.5		125.2	
10151-CAB	LTE-TDD (SC-FDMA, 50% RB, 20 MHz, QPSK)	X	7.21	67.6	21.8	9.28	149.5	±1.9 %
		Y	7.39	68.5	22.3		135.1	
		Z	7.19	67.5	21.7		147.3	
10154-CAC	LTE-FDD (SC-FDMA, 50% RB, 10 MHz, QPSK)	X	5.91	66.2	19.1	5.75	133.8	±1.2 %
		Y	6.04	66.8	19.4		139.4	
		Z	5.88	66.0	18.9		131.1	
10160-CAB	LTE-FDD (SC-FDMA, 50% RB, 15 MHz, QPSK)	X	6.36	66.7	19.3	5.82	139.0	±1.4 %
		Y	6.51	67.4	19.7		145.5	
		Z	6.31	66.4	19.0		136.5	
10169-CAB	LTE-FDD (SC-FDMA, 1 RB, 20 MHz, QPSK)	X	4.79	66.3	19.4	5.73	136.1	±1.2 %
		Y	4.90	67.0	19.8		141.5	
		Z	4.76	66.0	19.1		133.8	
10172-CAB	LTE-TDD (SC-FDMA, 1 RB, 20 MHz, QPSK)	X	5.66	68.8	22.7	9.21	138.2	±2.5 %
		Y	5.93	70.3	23.7		147.0	
		Z	5.68	68.6	22.6		136.7	
10175-CAC	LTE-FDD (SC-FDMA, 1 RB, 10 MHz, QPSK)	X	4.77	66.2	19.3	5.72	135.7	±1.2 %
		Y	4.92	67.1	19.8		141.2	
		Z	4.72	65.8	19.0		133.6	
10181-CAB	LTE-FDD (SC-FDMA, 1 RB, 15 MHz, QPSK)	X	4.77	66.2	19.3	5.72	134.8	±1.2 %
		Y	4.91	67.0	19.7		141.1	
		Z	4.76	66.0	19.1		132.8	
10196-CAB	IEEE 802.11n (HT Mixed, 6.5 Mbps, BPSK)	X	9.99	68.8	21.1	8.10	146.9	±2.5 %
		Y	9.71	68.4	21.0		127.0	
		Z	9.91	68.7	21.0		143.4	
10225-CAB	UMTS-FDD (HSPA+)	X	7.10	67.5	19.5	5.97	149.1	±1.2 %
		Y	6.98	67.4	19.5		128.9	
		Z	7.01	67.2	19.3		145.5	

10237-CAB	LTE-TDD (SC-FDMA, 1 RB, 10 MHz, QPSK)	X	5.68	68.9	22.8	9.21	139.9	±2.2 %
		Y	5.93	70.3	23.6		148.1	
		Z	5.70	68.8	22.7		137.5	
10252-CAB	LTE-TDD (SC-FDMA, 50% RB, 10 MHz, QPSK)	X	6.81	67.4	21.7	9.24	143.4	±2.2 %
		Y	6.93	68.0	22.2		129.3	
		Z	6.79	67.2	21.6		140.3	
10267-CAB	LTE-TDD (SC-FDMA, 100% RB, 10 MHz, QPSK)	X	7.23	67.7	21.9	9.30	149.4	±1.9 %
		Y	7.42	68.6	22.4		135.2	
		Z	7.19	67.4	21.6		146.2	
10275-CAB	UMTS-FDD (HSUPA, Subtest 5, 3GPP Rel8.4)	X	4.44	66.7	18.6	3.96	129.1	±0.7 %
		Y	4.57	67.4	18.9		134.5	
		Z	4.35	66.1	18.1		126.6	
10291-AAB	CDMA2000, RC3, SO55, Full Rate	X	3.64	66.9	18.6	3.46	140.9	±0.7 %
		Y	3.87	68.3	19.3		147.1	
		Z	3.61	66.5	18.2		138.4	
10292-AAB	CDMA2000, RC3, SO32, Full Rate	X	3.64	67.4	18.8	3.39	142.3	±0.5 %
		Y	3.85	68.5	19.3		148.3	
		Z	3.59	66.7	18.3		139.6	
10297-AAA	LTE-FDD (SC-FDMA, 50% RB, 20 MHz, QPSK)	X	6.23	66.6	19.2	5.81	136.3	±1.4 %
		Y	6.42	67.4	19.7		142.8	
		Z	6.19	66.3	19.0		133.9	
10311-AAA	LTE-FDD (SC-FDMA, 100% RB, 15 MHz, QPSK)	X	6.84	67.3	19.6	6.06	142.4	±1.4 %
		Y	6.98	67.8	19.9		149.5	
		Z	6.75	66.8	19.3		140.0	
10317-AAB	IEEE 802.11a WiFi 5 GHz (OFDM, 6 Mbps, 96pc duty cycle)	X	10.13	68.9	21.3	8.36	147.4	±2.7 %
		Y	9.84	68.4	21.1		127.5	
		Z	10.04	68.7	21.2		143.2	
10400-AAB	IEEE 802.11ac WiFi (20MHz, 64-QAM, 99pc duty cycle)	X	10.24	69.0	21.4	8.37	148.6	±2.7 %
		Y	9.92	68.4	21.2		126.6	
		Z	10.14	68.8	21.3		144.6	
10401-AAB	IEEE 802.11ac WiFi (40MHz, 64-QAM, 99pc duty cycle)	X	10.60	68.6	21.2	8.60	129.4	±3.0 %
		Y	10.77	69.1	21.5		136.8	
		Z	10.52	68.4	21.1		125.9	
10402-AAB	IEEE 802.11ac WiFi (80MHz, 64-QAM, 99pc duty cycle)	X	10.60	68.5	20.9	8.53	129.7	±3.0 %
		Y	11.01	69.5	21.5		139.1	
		Z	10.54	68.3	20.8		126.7	
10403-AAB	CDMA2000 (1xEV-DO, Rev. 0)	X	5.07	70.1	19.4	3.76	127.5	±0.5 %
		Y	5.47	71.9	20.2		133.6	
		Z	4.93	69.5	19.0		124.9	
10404-AAB	CDMA2000 (1xEV-DO, Rev. A)	X	5.01	70.2	19.5	3.77	149.3	±0.7 %
		Y	5.38	71.9	20.2		132.0	
		Z	4.94	69.9	19.2		146.4	

10415-AAA	IEEE 802.11b WiFi 2.4 GHz (DSSS, 1 Mbps, 99pc duty cycle)	X	3.20	71.2	19.8	1.54	126.8	±0.7 %
		Y	3.51	72.6	20.4		134.5	
		Z	2.79	68.1	18.1		148.4	
10416-AAA	IEEE 802.11g WiFi 2.4 GHz (ERP-OFDM, 6 Mbps, 99pc duty cycle)	X	10.07	68.8	21.2	8.23	147.8	±2.7 %
		Y	9.81	68.4	21.1		128.4	
		Z	10.00	68.7	21.1		144.0	
10417-AAA	IEEE 802.11a/h WiFi 5 GHz (OFDM, 6 Mbps, 99pc duty cycle)	X	10.07	68.8	21.2	8.23	148.4	±2.7 %
		Y	9.82	68.4	21.1		129.0	
		Z	9.99	68.7	21.1		144.6	

The reported uncertainty of measurement is stated as the standard uncertainty of measurement multiplied by the coverage factor $k=2$, which for a normal distribution corresponds to a coverage probability of approximately 95%.

^A The uncertainties of NormX,Y,Z do not affect the E^2 -field uncertainty inside TSL (see Pages 8 and 9).

^B Numerical linearization parameter: uncertainty not required.

^E Uncertainty is determined using the max. deviation from linear response applying rectangular distribution and is expressed for the square of the field value.

DASY/EASY - Parameters of Probe: EX3DV4 - SN:3914

Calibration Parameter Determined in Head Tissue Simulating Media

f (MHz) ^C	Relative Permittivity ^F	Conductivity (S/m) ^F	ConvF X	ConvF Y	ConvF Z	Alpha ^G	Depth ^G (mm)	Unct. (k=2)
750	41.9	0.89	9.82	9.82	9.82	0.39	0.92	± 12.0 %
835	41.5	0.90	9.50	9.50	9.50	0.43	0.83	± 12.0 %
1750	40.1	1.37	8.04	8.04	8.04	0.30	0.93	± 12.0 %
1900	40.0	1.40	7.86	7.86	7.86	0.35	0.86	± 12.0 %
2450	39.2	1.80	7.02	7.02	7.02	0.28	1.05	± 12.0 %
2600	39.0	1.96	6.82	6.82	6.82	0.26	1.17	± 12.0 %
5200	36.0	4.66	5.26	5.26	5.26	0.35	1.80	± 13.1 %
5300	35.9	4.76	5.06	5.06	5.06	0.35	1.80	± 13.1 %
5500	35.6	4.96	4.92	4.92	4.92	0.40	1.80	± 13.1 %
5600	35.5	5.07	4.73	4.73	4.73	0.40	1.80	± 13.1 %
5800	35.3	5.27	4.67	4.67	4.67	0.40	1.80	± 13.1 %

^C Frequency validity above 300 MHz of ± 100 MHz only applies for DASY v4.4 and higher (see Page 2), else it is restricted to ± 50 MHz. The uncertainty is the RSS of the ConvF uncertainty at calibration frequency and the uncertainty for the indicated frequency band. Frequency validity below 300 MHz is ± 10, 25, 40, 50 and 70 MHz for ConvF assessments at 30, 64, 128, 150 and 220 MHz respectively. Above 5 GHz frequency validity can be extended to ± 110 MHz.

^F At frequencies below 3 GHz, the validity of tissue parameters (ϵ and σ) can be relaxed to ± 10% if liquid compensation formula is applied to measured SAR values. At frequencies above 3 GHz, the validity of tissue parameters (ϵ and σ) is restricted to ± 5%. The uncertainty is the RSS of the ConvF uncertainty for indicated target tissue parameters.

^G Alpha/Depth are determined during calibration. SPEAG warrants that the remaining deviation due to the boundary effect after compensation is always less than ± 1% for frequencies below 3 GHz and below ± 2% for frequencies between 3-6 GHz at any distance larger than half the probe tip diameter from the boundary.

DASY/EASY - Parameters of Probe: EX3DV4 - SN:3914

Calibration Parameter Determined in Body Tissue Simulating Media

f (MHz) ^C	Relative Permittivity ^F	Conductivity (S/m) ^F	ConvF X	ConvF Y	ConvF Z	Alpha ^G	Depth (mm) ^G	Unct. (k=2)
750	55.5	0.96	9.53	9.53	9.53	0.33	1.09	± 12.0 %
835	55.2	0.97	9.49	9.49	9.49	0.27	1.25	± 12.0 %
1750	53.4	1.49	7.78	7.78	7.78	0.51	0.79	± 12.0 %
1900	53.3	1.52	7.49	7.49	7.49	0.73	0.64	± 12.0 %
2450	52.7	1.95	7.15	7.15	7.15	0.69	0.64	± 12.0 %
2600	52.5	2.16	6.84	6.84	6.84	0.80	0.57	± 12.0 %
5200	49.0	5.30	4.50	4.50	4.50	0.45	1.90	± 13.1 %
5300	48.9	5.42	4.33	4.33	4.33	0.45	1.90	± 13.1 %
5500	48.6	5.65	3.91	3.91	3.91	0.50	1.90	± 13.1 %
5600	48.5	5.77	3.89	3.89	3.89	0.50	1.90	± 13.1 %
5800	48.2	6.00	4.01	4.01	4.01	0.55	1.90	± 13.1 %

^C Frequency validity above 300 MHz of ± 100 MHz only applies for DASY v4.4 and higher (see Page 2), else it is restricted to ± 50 MHz. The uncertainty is the RSS of the ConvF uncertainty at calibration frequency and the uncertainty for the indicated frequency band. Frequency validity below 300 MHz is ± 10, 25, 40, 50 and 70 MHz for ConvF assessments at 30, 64, 128, 150 and 220 MHz respectively. Above 5 GHz frequency validity can be extended to ± 110 MHz.

^F At frequencies below 3 GHz, the validity of tissue parameters (ϵ and σ) can be relaxed to ± 10% if liquid compensation formula is applied to measured SAR values. At frequencies above 3 GHz, the validity of tissue parameters (ϵ and σ) is restricted to ± 5%. The uncertainty is the RSS of the ConvF uncertainty for indicated target tissue parameters.

^G Alpha/Depth are determined during calibration. SPEAG warrants that the remaining deviation due to the boundary effect after compensation is always less than ± 1% for frequencies below 3 GHz and below ± 2% for frequencies between 3-6 GHz at any distance larger than half the probe tip diameter from the boundary.

Frequency Response of E-Field (TEM-Cell:ifi110 EXX, Waveguide: R22)

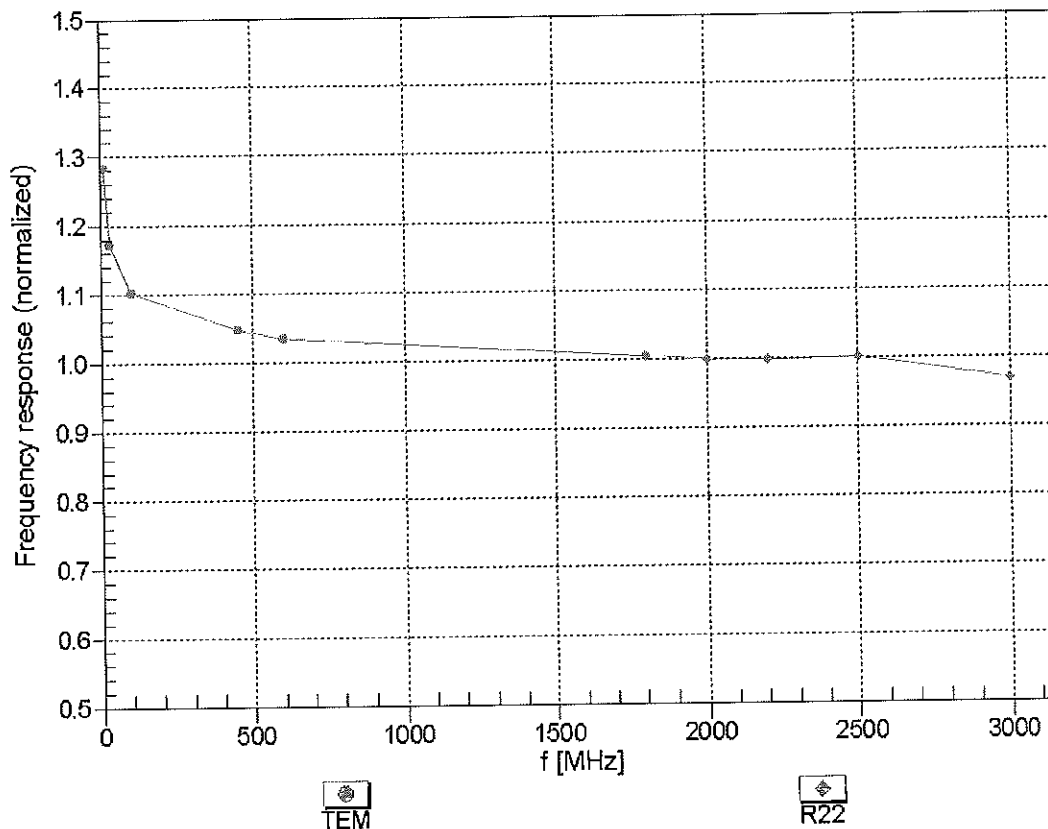

Uncertainty of Frequency Response of E-field: $\pm 6.3\%$ (k=2)

Receiving Pattern (ϕ), $\theta = 0^\circ$

f=600 MHz, TEM

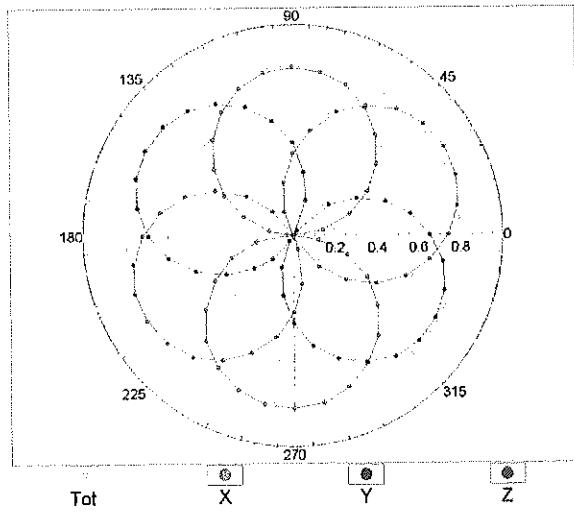

f=1800 MHz, R22

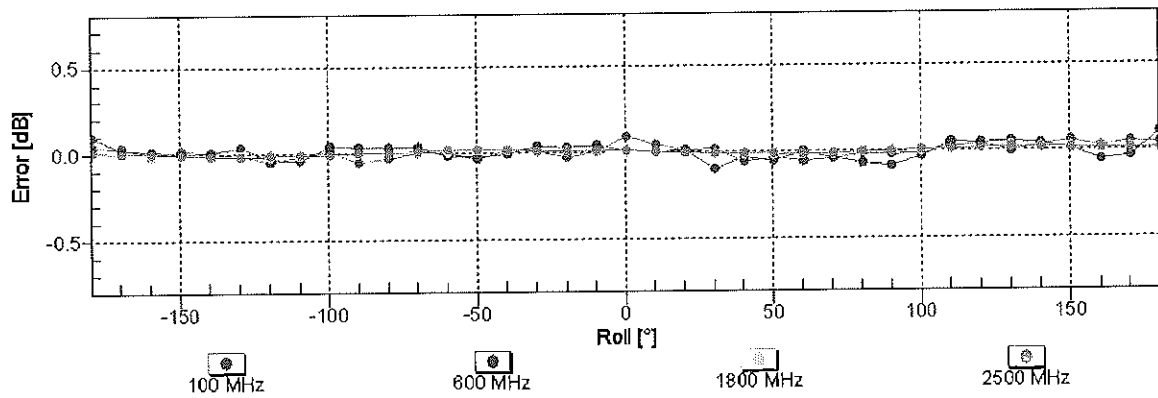
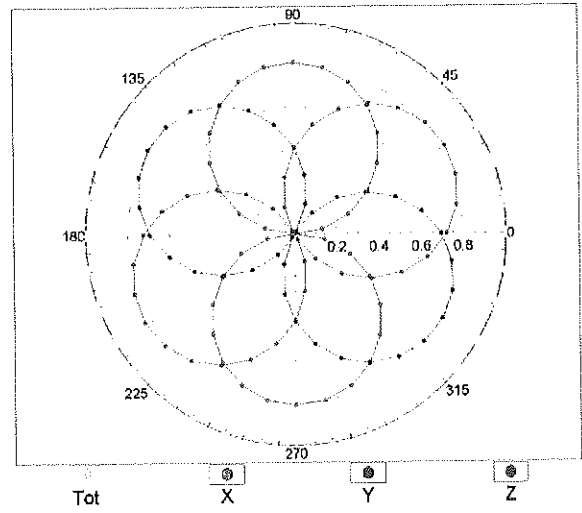

Uncertainty of Axial Isotropy Assessment: $\pm 0.5\%$ ($k=2$)

Dynamic Range f(SAR_{head}) (TEM cell , f_{eval}= 1900 MHz)

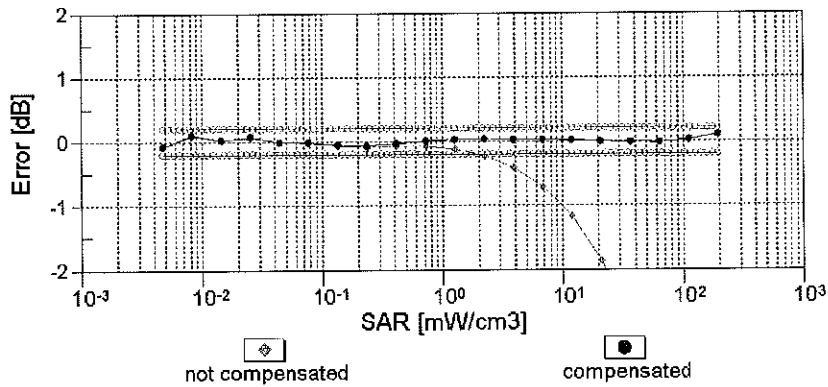
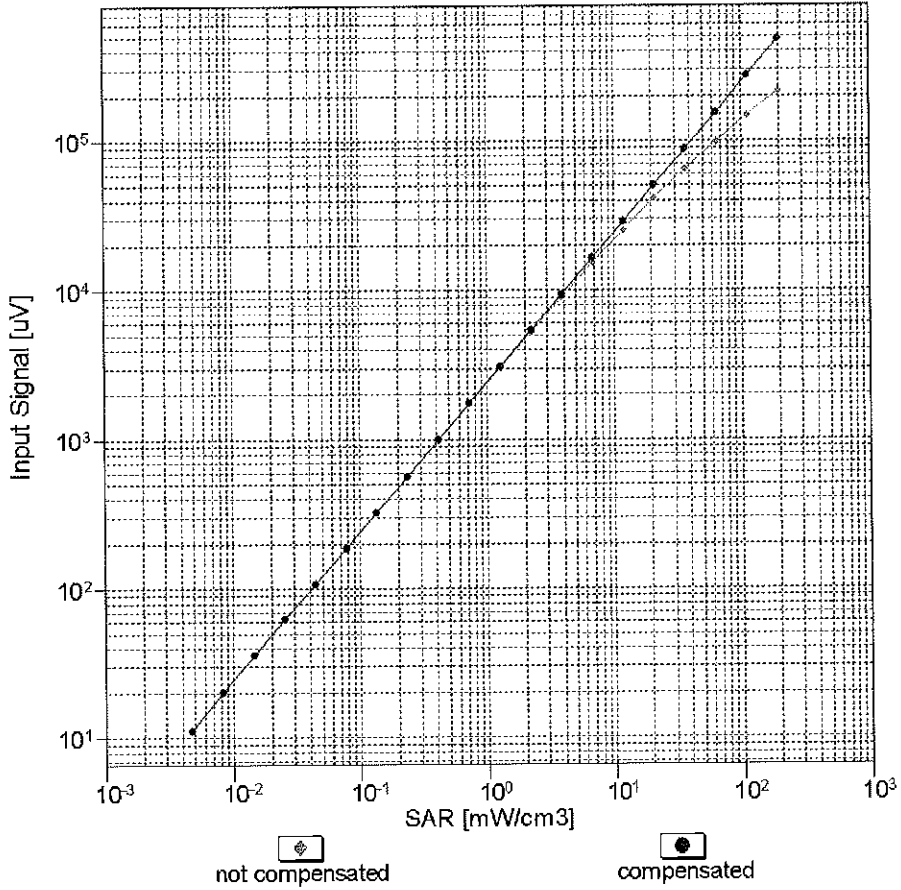

Uncertainty of Linearity Assessment: ± 0.6% (k=2)

Conversion Factor Assessment

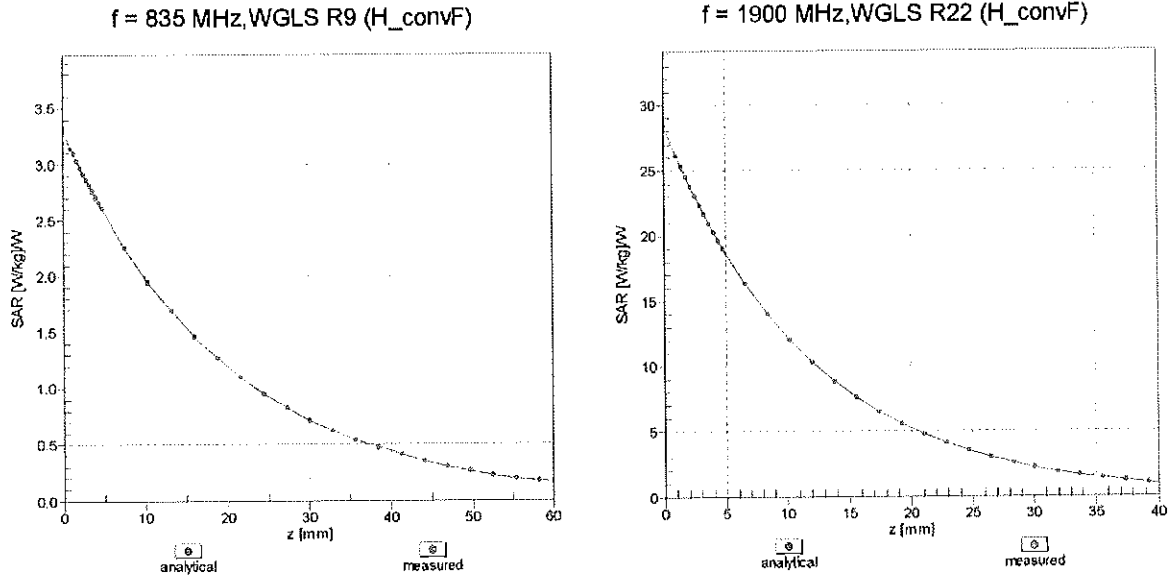

Deviation from Isotropy in Liquid Error (ϕ, θ), f = 900 MHz

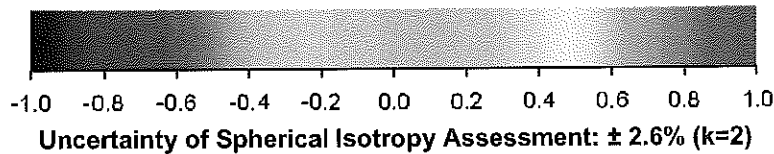
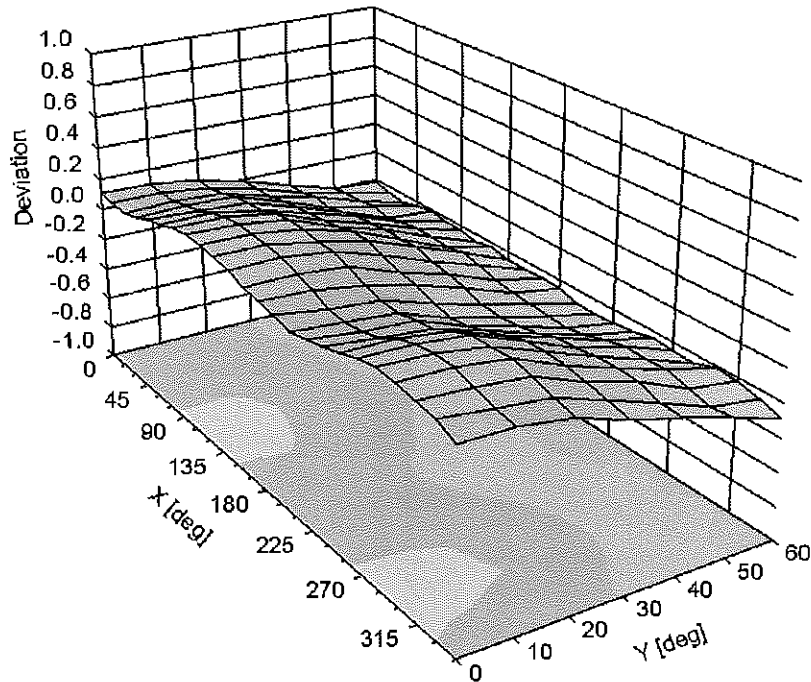

DASY/EASY - Parameters of Probe: EX3DV4 - SN:3914**Other Probe Parameters**

Sensor Arrangement	Triangular
Connector Angle (°)	-49.5
Mechanical Surface Detection Mode	enabled
Optical Surface Detection Mode	disabled
Probe Overall Length	337 mm
Probe Body Diameter	10 mm
Tip Length	9 mm
Tip Diameter	2.5 mm
Probe Tip to Sensor X Calibration Point	1 mm
Probe Tip to Sensor Y Calibration Point	1 mm
Probe Tip to Sensor Z Calibration Point	1 mm
Recommended Measurement Distance from Surface	1.4 mm



Accreditation No.: **SCS 0108**

Accredited by the Swiss Accreditation Service (SAS)
The Swiss Accreditation Service is one of the signatories to the EA
Multilateral Agreement for the recognition of calibration certificates

Certificate No: **D750V3-1003_Jan15**

Client **PC Test**

CALIBRATION CERTIFICATE

Object **D750V3 - SN: 1003**

Calibration procedure(s) **QA CAL-05.v9
Calibration procedure for dipole validation kits above 700 MHz**

CC
2/3/15

Calibration date: **January 16, 2015**

This calibration certificate documents the traceability to national standards, which realize the physical units of measurements (SI).
The measurements and the uncertainties with confidence probability are given on the following pages and are part of the certificate.

All calibrations have been conducted in the closed laboratory facility: environment temperature (22 ± 3)°C and humidity < 70%.

Calibration Equipment used (M&TE critical for calibration)

Primary Standards	ID #	Cal Date (Certificate No.)	Scheduled Calibration
Power meter EPM-442A	GB37480704	07-Oct-14 (No. 217-02020)	Oct-15
Power sensor HP 8481A	US37292783	07-Oct-14 (No. 217-02020)	Oct-15
Power sensor HP 8481A	MY41092317	07-Oct-14 (No. 217-02021)	Oct-15
Reference 20 dB Attenuator	SN: 5058 (20k)	03-Apr-14 (No. 217-01918)	Apr-15
Type-N mismatch combination	SN: 5047.2 / 06327	03-Apr-14 (No. 217-01921)	Apr-15
Reference Probe ES3DV3	SN: 3205	30-Dec-14 (No. ES3-3205_Dec14)	Dec-15
DAE4	SN: 601	18-Aug-14 (No. DAE4-601_Aug14)	Aug-15
Secondary Standards	ID #	Check Date (in house)	Scheduled Check
RF generator R&S SMT-06	100005	04-Aug-99 (in house check Oct-13)	In house check: Oct-16
Network Analyzer HP 8753E	US37390585 S4206	18-Oct-01 (in house check Oct-14)	In house check: Oct-15

Calibrated by: **Michael Weber** Name: Michael Weber Function: Laboratory Technician

Signature

Approved by: **Katja Pokovic** Name: Katja Pokovic Technical Manager

Issued: January 19, 2015

This calibration certificate shall not be reproduced except in full without written approval of the laboratory.



Accredited by the Swiss Accreditation Service (SAS)

The Swiss Accreditation Service is one of the signatories to the EA Multilateral Agreement for the recognition of calibration certificates

Glossary:

TSL	tissue simulating liquid
ConvF	sensitivity in TSL / NORM x,y,z
N/A	not applicable or not measured

Calibration is Performed According to the Following Standards:

- IEEE Std 1528-2013, "IEEE Recommended Practice for Determining the Peak Spatial-Averaged Specific Absorption Rate (SAR) in the Human Head from Wireless Communications Devices: Measurement Techniques", June 2013
- IEC 62209-1, "Procedure to measure the Specific Absorption Rate (SAR) for hand-held devices used in close proximity to the ear (frequency range of 300 MHz to 3 GHz)", February 2005
- KDB 865664, "SAR Measurement Requirements for 100 MHz to 6 GHz"

Additional Documentation:

- DASY4/5 System Handbook

Methods Applied and Interpretation of Parameters:

- Measurement Conditions:** Further details are available from the Validation Report at the end of the certificate. All figures stated in the certificate are valid at the frequency indicated.
- Antenna Parameters with TSL:** The dipole is mounted with the spacer to position its feed point exactly below the center marking of the flat phantom section, with the arms oriented parallel to the body axis.
- Feed Point Impedance and Return Loss:** These parameters are measured with the dipole positioned under the liquid filled phantom. The impedance stated is transformed from the measurement at the SMA connector to the feed point. The Return Loss ensures low reflected power. No uncertainty required.
- Electrical Delay:** One-way delay between the SMA connector and the antenna feed point. No uncertainty required.
- SAR measured:** SAR measured at the stated antenna input power.
- SAR normalized:** SAR as measured, normalized to an input power of 1 W at the antenna connector.
- SAR for nominal TSL parameters:** The measured TSL parameters are used to calculate the nominal SAR result.

The reported uncertainty of measurement is stated as the standard uncertainty of measurement multiplied by the coverage factor $k=2$, which for a normal distribution corresponds to a coverage probability of approximately 95%.

Measurement Conditions

DASY system configuration, as far as not given on page 1.

DASY Version	DASY5	V52.8.8
Extrapolation	Advanced Extrapolation	
Phantom	Modular Flat Phantom	
Distance Dipole Center - TSL	15 mm	with Spacer
Zoom Scan Resolution	dx, dy, dz = 5 mm	
Frequency	750 MHz ± 1 MHz	

Head TSL parameters

The following parameters and calculations were applied.

	Temperature	Permittivity	Conductivity
Nominal Head TSL parameters	22.0 °C	41.9	0.89 mho/m
Measured Head TSL parameters	(22.0 ± 0.2) °C	41.7 ± 6 %	0.91 mho/m ± 6 %
Head TSL temperature change during test	< 0.5 °C	----	----

SAR result with Head TSL

SAR averaged over 1 cm³ (1 g) of Head TSL	Condition	
SAR measured	250 mW input power	2.06 W/kg
SAR for nominal Head TSL parameters	normalized to 1W	8.09 W/kg ± 17.0 % (k=2)

SAR averaged over 10 cm³ (10 g) of Head TSL	condition	
SAR measured	250 mW input power	1.35 W/kg
SAR for nominal Head TSL parameters	normalized to 1W	5.32 W/kg ± 16.5 % (k=2)

Body TSL parameters

The following parameters and calculations were applied.

	Temperature	Permittivity	Conductivity
Nominal Body TSL parameters	22.0 °C	55.5	0.96 mho/m
Measured Body TSL parameters	(22.0 ± 0.2) °C	56.0 ± 6 %	0.99 mho/m ± 6 %
Body TSL temperature change during test	< 0.5 °C	----	----

SAR result with Body TSL

SAR averaged over 1 cm³ (1 g) of Body TSL	Condition	
SAR measured	250 mW input power	2.16 W/kg
SAR for nominal Body TSL parameters	normalized to 1W	8.46 W/kg ± 17.0 % (k=2)

SAR averaged over 10 cm³ (10 g) of Body TSL	condition	
SAR measured	250 mW input power	1.42 W/kg
SAR for nominal Body TSL parameters	normalized to 1W	5.58 W/kg ± 16.5 % (k=2)

Appendix (Additional assessments outside the scope of SCS0108)

Antenna Parameters with Head TSL

Impedance, transformed to feed point	53.7 Ω - 1.4 j Ω
Return Loss	- 28.5 dB

Antenna Parameters with Body TSL

Impedance, transformed to feed point	48.3 Ω - 3.8 j Ω
Return Loss	- 27.5 dB

General Antenna Parameters and Design

Electrical Delay (one direction)	1.043 ns
----------------------------------	----------

After long term use with 100W radiated power, only a slight warming of the dipole near the feedpoint can be measured.

The dipole is made of standard semirigid coaxial cable. The center conductor of the feeding line is directly connected to the second arm of the dipole. The antenna is therefore short-circuited for DC-signals. On some of the dipoles, small end caps are added to the dipole arms in order to improve matching when loaded according to the position as explained in the "Measurement Conditions" paragraph. The SAR data are not affected by this change. The overall dipole length is still according to the Standard.

No excessive force must be applied to the dipole arms, because they might bend or the soldered connections near the feedpoint may be damaged.

Additional EUT Data

Manufactured by	SPEAG
Manufactured on	January 21, 2009

DASY5 Validation Report for Head TSL

Date: 16.01.2015

Test Laboratory: SPEAG, Zurich, Switzerland

DUT: Dipole 750 MHz; Type: D750V3; Serial: D750V3 - SN: 1003

Communication System: UID 0 - CW; Frequency: 750 MHz

Medium parameters used: $f = 750 \text{ MHz}$; $\sigma = 0.91 \text{ S/m}$; $\epsilon_r = 41.7$; $\rho = 1000 \text{ kg/m}^3$

Phantom section: Flat Section

Measurement Standard: DASY5 (IEEE/IEC/ANSI C63.19-2011)

DASY52 Configuration:

- Probe: ES3DV3 - SN3205; ConvF(6.44, 6.44, 6.44); Calibrated: 30.12.2014;
- Sensor-Surface: 3mm (Mechanical Surface Detection)
- Electronics: DAE4 Sn601; Calibrated: 18.08.2014
- Phantom: Flat Phantom 4.9L; Type: QD000P49AA; Serial: 1001
- DASY52 52.8.8(1222); SEMCAD X 14.6.10(7331)

Dipole Calibration for Head Tissue/Pin=250 mW, d=15mm/Zoom Scan (7x7x7)/Cube 0:

Measurement grid: $dx=5\text{mm}$, $dy=5\text{mm}$, $dz=5\text{mm}$

Reference Value = 53.08 V/m; Power Drift = 0.00 dB

Peak SAR (extrapolated) = 3.05 W/kg

SAR(1 g) = 2.06 W/kg; SAR(10 g) = 1.35 W/kg

Maximum value of SAR (measured) = 2.41 W/kg

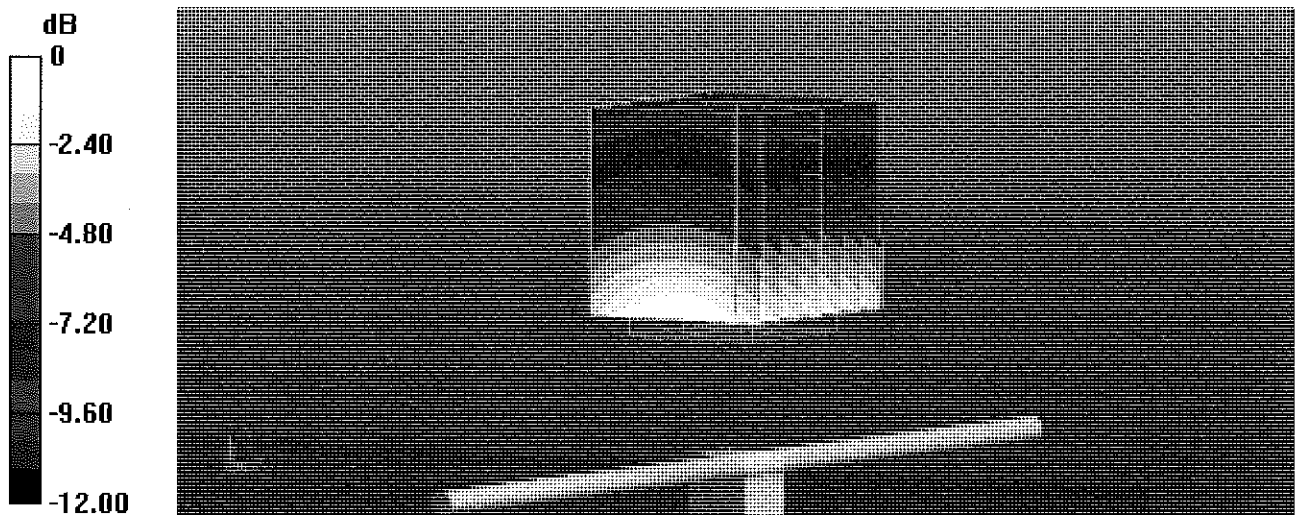

0 dB = 2.41 W/kg = 3.82 dBW/kg

Impedance Measurement Plot for Head TSL

16 Jan 2015 16:07:22
 [CH1] S11 1 U FS 1: 53.666 Ω -1.3730 Δ 154.55 pF 750.000 000 MHz

*
 Del
 CA

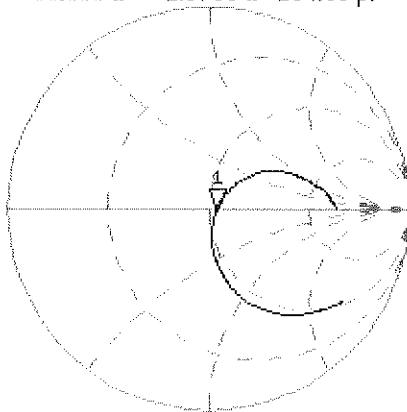

Avg
 16

H1d

CH2 S11 LOG 5 dB/REF -20 dB 1:-28.456 dB 750.000 000 MHz

CA

Avg
 16

H1d

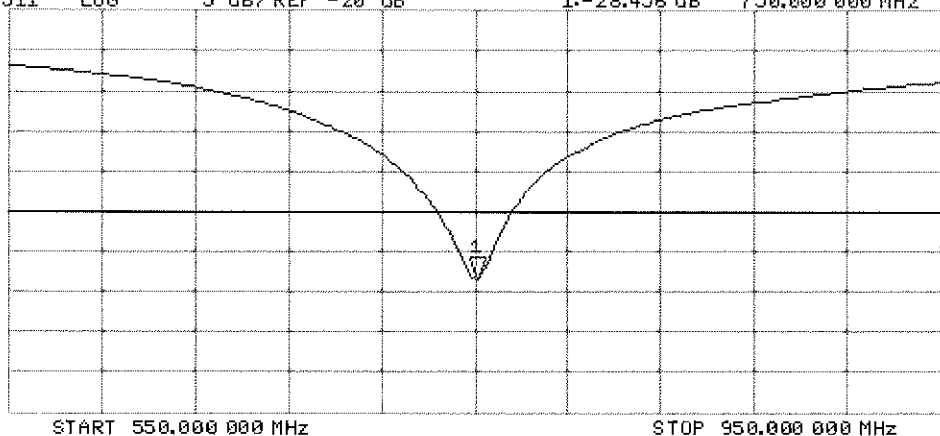

DASY5 Validation Report for Body TSL

Date: 16.01.2015

Test Laboratory: SPEAG, Zurich, Switzerland

DUT: Dipole 750 MHz; Type: D750V3; Serial: D750V3 - SN: 1003

Communication System: UID 0 - CW; Frequency: 750 MHz

Medium parameters used: $f = 750$ MHz; $\sigma = 0.99$ S/m; $\epsilon_r = 56$; $\rho = 1000$ kg/m³

Phantom section: Flat Section

Measurement Standard: DASY5 (IEEE/IEC/ANSI C63.19-2011)

DASY52 Configuration:

- Probe: ES3DV3 - SN3205; ConvF(6.21, 6.21, 6.21); Calibrated: 30.12.2014;
- Sensor-Surface: 3mm (Mechanical Surface Detection)
- Electronics: DAE4 Sn601; Calibrated: 18.08.2014
- Phantom: Flat Phantom 4.9L; Type: QD000P49AA; Serial: 1001
- DASY52 52.8.8(1222); SEMCAD X 14.6.10(7331)

Dipole Calibration for Body Tissue/Pin=250 mW, d=15mm/Zoom Scan (7x7x7)/Cube 0:

Measurement grid: dx=5mm, dy=5mm, dz=5mm

Reference Value = 52.21 V/m; Power Drift = -0.00 dB

Peak SAR (extrapolated) = 3.16 W/kg

SAR(1 g) = 2.16 W/kg; SAR(10 g) = 1.42 W/kg

Maximum value of SAR (measured) = 2.52 W/kg

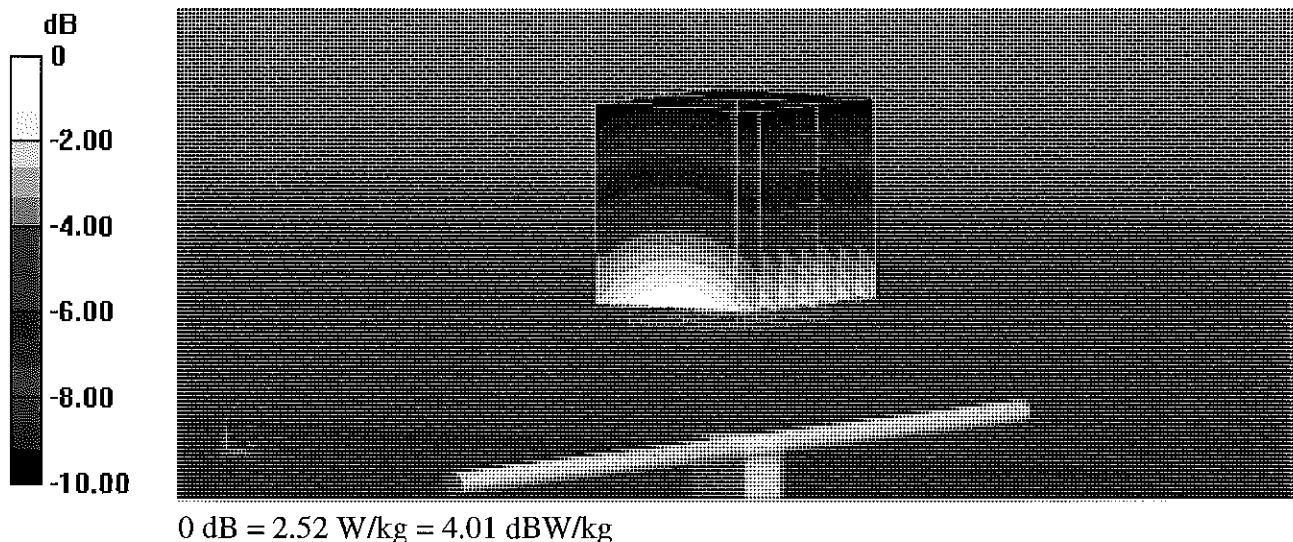

Impedance Measurement Plot for Body TSL

16 Jan 2015 13:37:35
[CH1] S11 1 U FS 1: 48.268 Ω -3.7676 Ω 56.324 pF 750.000 000 MHz

*
De1
CA

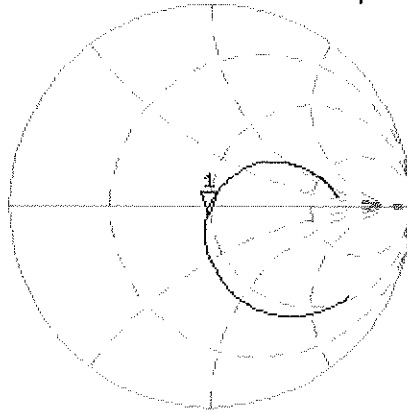

Avg
16

H1d

CH2 S11 LOG 5 dB/REF -20 dB 1:-27.498 dB 750.000 000 MHz

CA

Avg
16

H1d

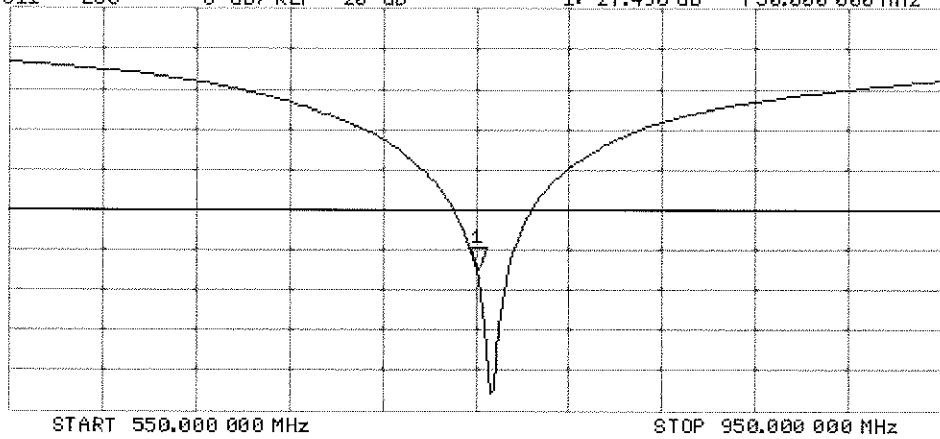

**Calibration Laboratory of
Schmid & Partner
Engineering AG**
Zeughausstrasse 43, 8004 Zurich, Switzerland



S Schweizerischer Kalibrierdienst
C Service suisse d'étalonnage
S Servizio svizzero di taratura
S Swiss Calibration Service

Accredited by the Swiss Accreditation Service (SAS)
The Swiss Accreditation Service is one of the signatories to the EA
Multilateral Agreement for the recognition of calibration certificates

Accreditation No.: **SCS 108**

Client **PC Test**

Certificate No: **D835V2-4d133_Jul14**

CALIBRATION CERTIFICATE

Object **D835V2 - SN: 4d133**

Calibration procedure(s) **QA CAL-05.v9
Calibration procedure for dipole validation kits above 700 MHz**

CC
W/G/M

Calibration date: **July 24, 2014**

This calibration certificate documents the traceability to national standards, which realize the physical units of measurements (SI).
The measurements and the uncertainties with confidence probability are given on the following pages and are part of the certificate.

All calibrations have been conducted in the closed laboratory facility: environment temperature (22 ± 3)°C and humidity < 70%.

Calibration Equipment used (M&TE critical for calibration)

Primary Standards	ID #	Cal Date (Certificate No.)	Scheduled Calibration
Power meter EPM-442A	GB37480704	09-Oct-13 (No. 217-01827)	Oct-14
Power sensor HP 8481A	US37292783	09-Oct-13 (No. 217-01827)	Oct-14
Power sensor HP 8481A	MY41092317	09-Oct-13 (No. 217-01828)	Oct-14
Reference 20 dB Attenuator	SN: 5058 (20k)	03-Apr-14 (No. 217-01918)	Apr-15
Type-N mismatch combination	SN: 5047.2 / 06327	03-Apr-14 (No. 217-01921)	Apr-15
Reference Probe ES3DV3	SN: 3205	30-Dec-13 (No. ES3-3205_Dec13)	Dec-14
DAE4	SN: 601	30-Apr-14 (No. DAE4-601_Apr14)	Apr-15
Secondary Standards	ID #	Check Date (in house)	Scheduled Check
RF generator R&S SMT-06	100005	04-Aug-99 (in house check Oct-13)	In house check: Oct-16
Network Analyzer HP 8763E	US37390585 S4206	18-Oct-01 (in house check Oct-13)	In house check: Oct-14

Calibrated by: **Jeton Kastrali** (Name), **Laboratory Technician** (Function), *[Signature]* (Signature)

Approved by: **Katja Pokovic** (Name), **Technical Manager** (Function), *[Signature]* (Signature)

Issued: July 24, 2014

This calibration certificate shall not be reproduced except in full without written approval of the laboratory.

**Calibration Laboratory of
Schmid & Partner
Engineering AG**
Zeughausstrasse 43, 8004 Zurich, Switzerland



S Schweizerischer Kalibrierdienst
C Service suisse d'étalonnage
S Servizio svizzero di taratura
S Swiss Calibration Service

Accredited by the Swiss Accreditation Service (SAS)
The Swiss Accreditation Service is one of the signatories to the EA
Multilateral Agreement for the recognition of calibration certificates

Accreditation No.: **SCS 108**

Glossary:

TSL	tissue simulating liquid
ConvF	sensitivity in TSL / NORM x,y,z
N/A	not applicable or not measured

Calibration is Performed According to the Following Standards:

- IEEE Std 1528-2013, "IEEE Recommended Practice for Determining the Peak Spatial-Averaged Specific Absorption Rate (SAR) in the Human Head from Wireless Communications Devices: Measurement Techniques", June 2013
- IEC 62209-1, "Procedure to measure the Specific Absorption Rate (SAR) for hand-held devices used in close proximity to the ear (frequency range of 300 MHz to 3 GHz)", February 2005
- KDB 865664, "SAR Measurement Requirements for 100 MHz to 6 GHz"

Additional Documentation:

- DASY4/5 System Handbook

Methods Applied and Interpretation of Parameters:

- Measurement Conditions:* Further details are available from the Validation Report at the end of the certificate. All figures stated in the certificate are valid at the frequency indicated.
- Antenna Parameters with TSL:* The dipole is mounted with the spacer to position its feed point exactly below the center marking of the flat phantom section, with the arms oriented parallel to the body axis.
- Feed Point Impedance and Return Loss:* These parameters are measured with the dipole positioned under the liquid filled phantom. The impedance stated is transformed from the measurement at the SMA connector to the feed point. The Return Loss ensures low reflected power. No uncertainty required.
- Electrical Delay:* One-way delay between the SMA connector and the antenna feed point. No uncertainty required.
- SAR measured:* SAR measured at the stated antenna input power.
- SAR normalized:* SAR as measured, normalized to an input power of 1 W at the antenna connector.
- SAR for nominal TSL parameters:* The measured TSL parameters are used to calculate the nominal SAR result.

The reported uncertainty of measurement is stated as the standard uncertainty of measurement multiplied by the coverage factor $k=2$, which for a normal distribution corresponds to a coverage probability of approximately 95%.

Measurement Conditions

DASY system configuration, as far as not given on page 1.

DASY Version	DASY5	V52.8.8
Extrapolation	Advanced Extrapolation	
Phantom	Modular Flat Phantom	
Distance Dipole Center - TSL	15 mm	with Spacer
Zoom Scan Resolution	dx, dy, dz = 5 mm	
Frequency	835 MHz ± 1 MHz	

Head TSL parameters

The following parameters and calculations were applied.

	Temperature	Permittivity	Conductivity
Nominal Head TSL parameters	22.0 °C	41.5	0.90 mho/m
Measured Head TSL parameters	(22.0 ± 0.2) °C	41.1 ± 6 %	0.94 mho/m ± 6 %
Head TSL temperature change during test	< 0.5 °C	----	----

SAR result with Head TSL

SAR averaged over 1 cm ³ (1 g) of Head TSL	Condition	
SAR measured	250 mW input power	2.38 W/kg
SAR for nominal Head TSL parameters	normalized to 1W	9.20 W/kg ± 17.0 % (k=2)

SAR averaged over 10 cm ³ (10 g) of Head TSL	condition	
SAR measured	250 mW input power	1.53 W/kg
SAR for nominal Head TSL parameters	normalized to 1W	5.96 W/kg ± 16.5 % (k=2)

Body TSL parameters

The following parameters and calculations were applied.

	Temperature	Permittivity	Conductivity
Nominal Body TSL parameters	22.0 °C	55.2	0.97 mho/m
Measured Body TSL parameters	(22.0 ± 0.2) °C	53.8 ± 6 %	1.02 mho/m ± 6 %
Body TSL temperature change during test	< 0.5 °C	----	----

SAR result with Body TSL

SAR averaged over 1 cm ³ (1 g) of Body TSL	Condition	
SAR measured	250 mW input power	2.44 W/kg
SAR for nominal Body TSL parameters	normalized to 1W	9.35 W/kg ± 17.0 % (k=2)

SAR averaged over 10 cm ³ (10 g) of Body TSL	condition	
SAR measured	250 mW input power	1.59 W/kg
SAR for nominal Body TSL parameters	normalized to 1W	6.15 W/kg ± 16.5 % (k=2)

Appendix (Additional assessments outside the scope of SCS108)

Antenna Parameters with Head TSL

Impedance, transformed to feed point	51.6 Ω - 1.0 $j\Omega$
Return Loss	- 34.7 dB

Antenna Parameters with Body TSL

Impedance, transformed to feed point	47.8 Ω - 3.3 $j\Omega$
Return Loss	- 27.8 dB

General Antenna Parameters and Design

Electrical Delay (one direction)	1.395 ns
----------------------------------	----------

After long term use with 100W radiated power, only a slight warming of the dipole near the feedpoint can be measured.

The dipole is made of standard semirigid coaxial cable. The center conductor of the feeding line is directly connected to the second arm of the dipole. The antenna is therefore short-circuited for DC-signals. On some of the dipoles, small end caps are added to the dipole arms in order to improve matching when loaded according to the position as explained in the "Measurement Conditions" paragraph. The SAR data are not affected by this change. The overall dipole length is still according to the Standard.

No excessive force must be applied to the dipole arms, because they might bend or the soldered connections near the feedpoint may be damaged.

Additional EUT Data

Manufactured by	SPEAG
Manufactured on	July 22, 2011

DASY5 Validation Report for Head TSL

Date: 24.07.2014

Test Laboratory: SPEAG, Zurich, Switzerland

DUT: Dipole 835 MHz; Type: D835V2; Serial: D835V2 - SN: 4d133

Communication System: UID 0 - CW; Frequency: 835 MHz

Medium parameters used: $f = 835$ MHz; $\sigma = 0.94$ S/m; $\epsilon_r = 41.1$; $\rho = 1000$ kg/m³

Phantom section: Flat Section

Measurement Standard: DASY5 (IEEE/IEC/ANSI C63.19-2011)

DASY52 Configuration:

- Probe: ES3DV3 - SN3205; ConvF(6.22, 6.22, 6.22); Calibrated: 30.12.2013;
- Sensor-Surface: 3mm (Mechanical Surface Detection)
- Electronics: DAE4 Sn601; Calibrated: 30.04.2014
- Phantom: Flat Phantom 4.9L; Type: QD000P49AA; Serial: 1001
- DASY52 52.8.8(1222); SEMCAD X 14.6.10(7331)

Dipole Calibration for Head Tissue/Pin=250 mW, d=15mm/Zoom Scan (7x7x7)/Cube 0:

Measurement grid: dx=5mm, dy=5mm, dz=5mm

Reference Value = 56.07 V/m; Power Drift = 0.03 dB

Peak SAR (extrapolated) = 3.58 W/kg

SAR(1 g) = 2.38 W/kg; SAR(10 g) = 1.53 W/kg

Maximum value of SAR (measured) = 2.79 W/kg

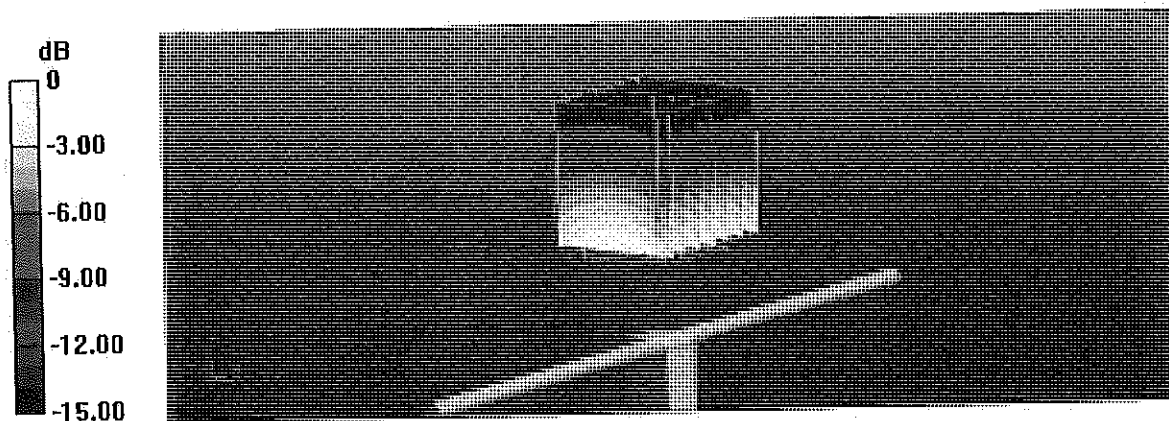

0 dB = 2.79 W/kg = 4.46 dBW/kg

Impedance Measurement Plot for Head TSL

24 Jul 2014 11:33:11

[CHI] S11 1 U F6

Z: 51.553 Ω -1.0293 Ω 105.19 pF 835.000 000 MHz

De1

CA

Avg
16

H1d

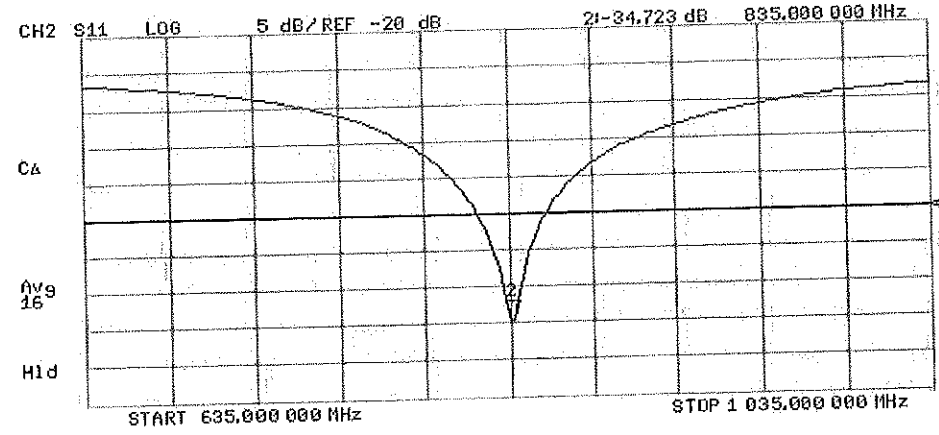
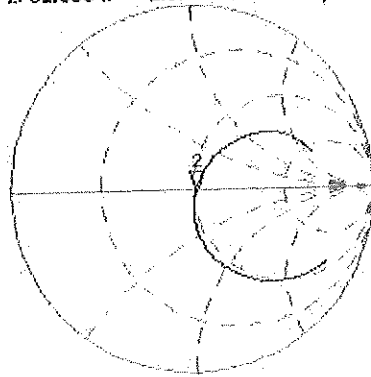

DASY5 Validation Report for Body TSL

Date: 17.07.2014

Test Laboratory: SPEAG, Zurich, Switzerland

DUT: Dipole 835 MHz; Type: D835V2; Serial: D835V2 - SN: 4d133

Communication System: UID 0 - CW; Frequency: 835 MHz
Medium parameters used: $f = 835$ MHz; $\sigma = 1.02$ S/m; $\epsilon_r = 53.8$; $\rho = 1000$ kg/m³
Phantom section: Flat Section
Measurement Standard: DASY5 (IEEE/IEC/ANSI C63.19-2011)

DASY52 Configuration:

- Probe: ES3DV3 - SN3205; ConvF(6.09, 6.09, 6.09); Calibrated: 30.12.2013;
- Sensor-Surface: 3mm (Mechanical Surface Detection)
- Electronics: DAE4 Sn601; Calibrated: 30.04.2014
- Phantom: Flat Phantom 4.9L; Type: QD000P49AA; Serial: 1001
- DASY52 52.8.8(1222); SEMCAD X 14.6.10(7331)

Dipole Calibration for Body Tissue/Pin=250 mW, d=15mm/Zoom Scan (7x7x7)/Cube 0:

Measurement grid: dx=5mm, dy=5mm, dz=5mm
Reference Value = 54.61 V/m; Power Drift = -0.01 dB
Peak SAR (extrapolated) = 3.59 W/kg
SAR(1 g) = 2.44 W/kg; SAR(10 g) = 1.59 W/kg
Maximum value of SAR (measured) = 2.84 W/kg

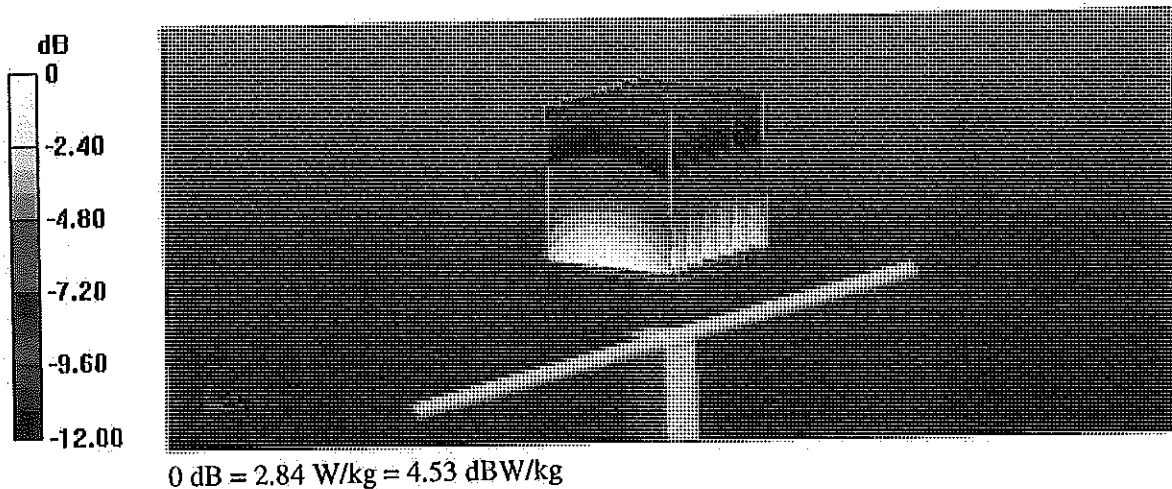

Impedance Measurement Plot for Body TSL

17 Jul 2014 13:43:24

CH1 S11 1 U F8

1: 47.799 Ω -3.3184 Ω 57.439 pF

835.000 000 MHz

*
Del
CA

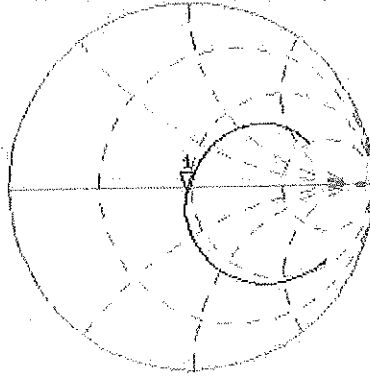

Avg
16

H1d

CH2 S11 LOG 5 dB/REF -20 dB 1:-27.007 dB 835.000 000 MHz

CA

Avg
16

H1d

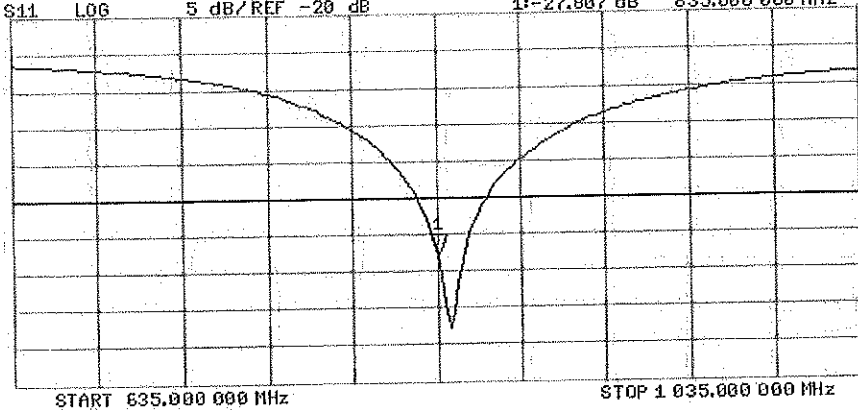

**Calibration Laboratory of
Schmid & Partner
Engineering AG**
Zeughausstrasse 43, 8004 Zurich, Switzerland



S Schweizerischer Kalibrierdienst
C Service suisse d'étalonnage
S Servizio svizzero di taratura
S Swiss Calibration Service

Accredited by the Swiss Accreditation Service (SAS)
The Swiss Accreditation Service is one of the signatories to the EA
Multilateral Agreement for the recognition of calibration certificates

Accreditation No.: **SCS 108**

Client **PC Test**

Certificate No: **D835V2-4d119_Apr14**

CALIBRATION CERTIFICATE

Object **D835V2 - SN: 4d119**

Calibration procedure(s) **QA CAL-05.v9
Calibration procedure for dipole validation kits above 700 MHz**

OCV
4/25/14

Calibration date: **April 07, 2014**

This calibration certificate documents the traceability to national standards, which realize the physical units of measurements (SI).
The measurements and the uncertainties with confidence probability are given on the following pages and are part of the certificate.

All calibrations have been conducted in the closed laboratory facility: environment temperature (22 ± 3)°C and humidity < 70%.

Calibration Equipment used (M&TE critical for calibration)

Primary Standards	ID #	Cal Date (Certificate No.)	Scheduled Calibration
Power meter EPM-442A	GB37480704	09-Oct-13 (No. 217-01827)	Oct-14
Power sensor HP 8481A	US37292783	09-Oct-13 (No. 217-01827)	Oct-14
Power sensor HP 8481A	MY41092317	09-Oct-13 (No. 217-01828)	Oct-14
Reference 20 dB Attenuator	SN: 5058 (20k)	03-Apr-14 (No. 217-01918)	Apr-15
Type-N mismatch combination	SN: 5047.2 / 06327	03-Apr-14 (No. 217-01921)	Apr-15
Reference Probe ES3DV3	SN: 3205	30-Dec-13 (No. ES3-3205_Dec13)	Dec-14
DAE4	SN: 601	25-Apr-13 (No. DAE4-601_Apr13)	Apr-14
Secondary Standards	ID #	Check Date (in house)	Scheduled Check
RF generator R&S SMT-06	100005	04-Aug-99 (in house check Oct-13)	In house check: Oct-16
Network Analyzer HP 8753E	US37390585 S4206	18-Oct-01 (in house check Oct-13)	In house check: Oct-14

Calibrated by: **Leif Klynsner** Function: **Laboratory Technician**

Signature: *Leif Klynsner*

Approved by: **Katja Pokovic** Technical Manager

Katja Pokovic

Issued: April 9, 2014

This calibration certificate shall not be reproduced except in full without written approval of the laboratory.



Accredited by the Swiss Accreditation Service (SAS)
The Swiss Accreditation Service is one of the signatories to the EA
Multilateral Agreement for the recognition of calibration certificates

Accreditation No.: **SCS 108**

Glossary:

TSL	tissue simulating liquid
ConvF	sensitivity in TSL / NORM x,y,z
N/A	not applicable or not measured

Calibration is Performed According to the Following Standards:

- a) IEEE Std 1528-2013, "IEEE Recommended Practice for Determining the Peak Spatial-Averaged Specific Absorption Rate (SAR) in the Human Head from Wireless Communications Devices: Measurement Techniques", June 2013
- b) IEC 62209-1, "Procedure to measure the Specific Absorption Rate (SAR) for hand-held devices used in close proximity to the ear (frequency range of 300 MHz to 3 GHz)", February 2005
- c) KDB 865664, "SAR Measurement Requirements for 100 MHz to 6 GHz"

Additional Documentation:

- d) DASY4/5 System Handbook

Methods Applied and Interpretation of Parameters:

- *Measurement Conditions:* Further details are available from the Validation Report at the end of the certificate. All figures stated in the certificate are valid at the frequency indicated.
- *Antenna Parameters with TSL:* The dipole is mounted with the spacer to position its feed point exactly below the center marking of the flat phantom section, with the arms oriented parallel to the body axis.
- *Feed Point Impedance and Return Loss:* These parameters are measured with the dipole positioned under the liquid filled phantom. The impedance stated is transformed from the measurement at the SMA connector to the feed point. The Return Loss ensures low reflected power. No uncertainty required.
- *Electrical Delay:* One-way delay between the SMA connector and the antenna feed point. No uncertainty required.
- *SAR measured:* SAR measured at the stated antenna input power.
- *SAR normalized:* SAR as measured, normalized to an input power of 1 W at the antenna connector.
- *SAR for nominal TSL parameters:* The measured TSL parameters are used to calculate the nominal SAR result.

The reported uncertainty of measurement is stated as the standard uncertainty of measurement multiplied by the coverage factor $k=2$, which for a normal distribution corresponds to a coverage probability of approximately 95%.

Measurement Conditions

DASY system configuration, as far as not given on page 1.

DASY Version	DASY5	V52.8.7
Extrapolation	Advanced Extrapolation	
Phantom	Modular Flat Phantom	
Distance Dipole Center - TSL	15 mm	with Spacer
Zoom Scan Resolution	dx, dy, dz = 5 mm	
Frequency	835 MHz ± 1 MHz	

Head TSL parameters

The following parameters and calculations were applied.

	Temperature	Permittivity	Conductivity
Nominal Head TSL parameters	22.0 °C	41.5	0.90 mho/m
Measured Head TSL parameters	(22.0 ± 0.2) °C	41.6 ± 6 %	0.94 mho/m ± 6 %
Head TSL temperature change during test	< 0.5 °C	----	----

SAR result with Head TSL

SAR averaged over 1 cm ³ (1 g) of Head TSL	Condition	
SAR measured	250 mW input power	2.38 W/kg
SAR for nominal Head TSL parameters	normalized to 1W	9.22 W/kg ± 17.0 % (k=2)

SAR averaged over 10 cm ³ (10 g) of Head TSL	condition	
SAR measured	250 mW input power	1.53 W/kg
SAR for nominal Head TSL parameters	normalized to 1W	5.97 W/kg ± 16.5 % (k=2)

Body TSL parameters

The following parameters and calculations were applied.

	Temperature	Permittivity	Conductivity
Nominal Body TSL parameters	22.0 °C	55.2	0.97 mho/m
Measured Body TSL parameters	(22.0 ± 0.2) °C	53.6 ± 6 %	1.02 mho/m ± 6 %
Body TSL temperature change during test	< 0.5 °C	----	----

SAR result with Body TSL

SAR averaged over 1 cm ³ (1 g) of Body TSL	Condition	
SAR measured	250 mW input power	2.44 W/kg
SAR for nominal Body TSL parameters	normalized to 1W	9.34 W/kg ± 17.0 % (k=2)

SAR averaged over 10 cm ³ (10 g) of Body TSL	condition	
SAR measured	250 mW input power	1.59 W/kg
SAR for nominal Body TSL parameters	normalized to 1W	6.15 W/kg ± 16.5 % (k=2)

Appendix

Antenna Parameters with Head TSL

Impedance, transformed to feed point	51.2 Ω - 1.6 j Ω
Return Loss	- 34.0 dB

Antenna Parameters with Body TSL

Impedance, transformed to feed point	46.3 Ω - 4.5 j Ω
Return Loss	- 24.4 dB

General Antenna Parameters and Design

Electrical Delay (one direction)	1.386 ns
----------------------------------	----------

After long term use with 100W radiated power, only a slight warming of the dipole near the feedpoint can be measured.

The dipole is made of standard semirigid coaxial cable. The center conductor of the feeding line is directly connected to the second arm of the dipole. The antenna is therefore short-circuited for DC-signals. On some of the dipoles, small end caps are added to the dipole arms in order to improve matching when loaded according to the position as explained in the "Measurement Conditions" paragraph. The SAR data are not affected by this change. The overall dipole length is still according to the Standard.

No excessive force must be applied to the dipole arms, because they might bend or the soldered connections near the feedpoint may be damaged.

Additional EUT Data

Manufactured by	SPEAG
Manufactured on	June 29, 2010

DASY5 Validation Report for Head TSL

Date: 07.04.2014

Test Laboratory: SPEAG, Zurich, Switzerland

DUT: Dipole 835 MHz; Type: D835V2; Serial: D835V2 - SN: 4d119

Communication System: UID 0 - CW; Frequency: 835 MHz

Medium parameters used: $f = 835$ MHz; $\sigma = 0.94$ S/m; $\epsilon_r = 41.6$; $\rho = 1000$ kg/m³

Phantom section: Flat Section

Measurement Standard: DASY5 (IEEE/IEC/ANSI C63.19-2007)

DASY52 Configuration:

- Probe: ES3DV3 - SN3205; ConvF(6.22, 6.22, 6.22); Calibrated: 30.12.2013;
- Sensor-Surface: 3mm (Mechanical Surface Detection)
- Electronics: DAE4 Sn601; Calibrated: 25.04.2013
- Phantom: Flat Phantom 4.9L; Type: QD000P49AA; Serial: 1001
- DASY52 52.8.7(1137); SEMCAD X 14.6.10(7164)

Dipole Calibration for Head Tissue/Pin=250 mW, d=15mm/Zoom Scan (7x7x7)/Cube 0:

Measurement grid: dx=5mm, dy=5mm, dz=5mm

Reference Value = 56.289 V/m; Power Drift = 0.01 dB

Peak SAR (extrapolated) = 3.59 W/kg

SAR(1 g) = 2.38 W/kg; SAR(10 g) = 1.53 W/kg

Maximum value of SAR (measured) = 2.80 W/kg

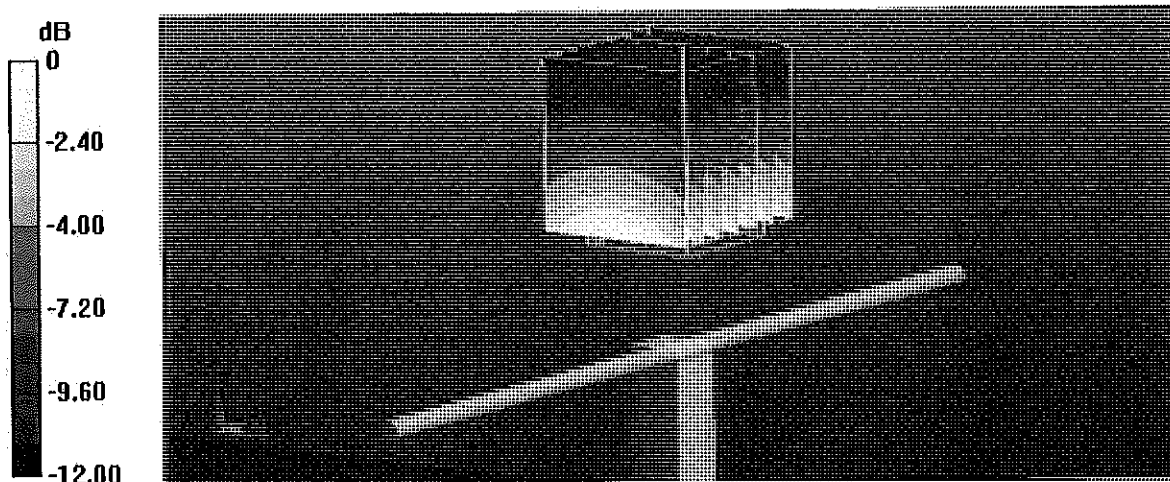

Impedance Measurement Plot for Head TSL

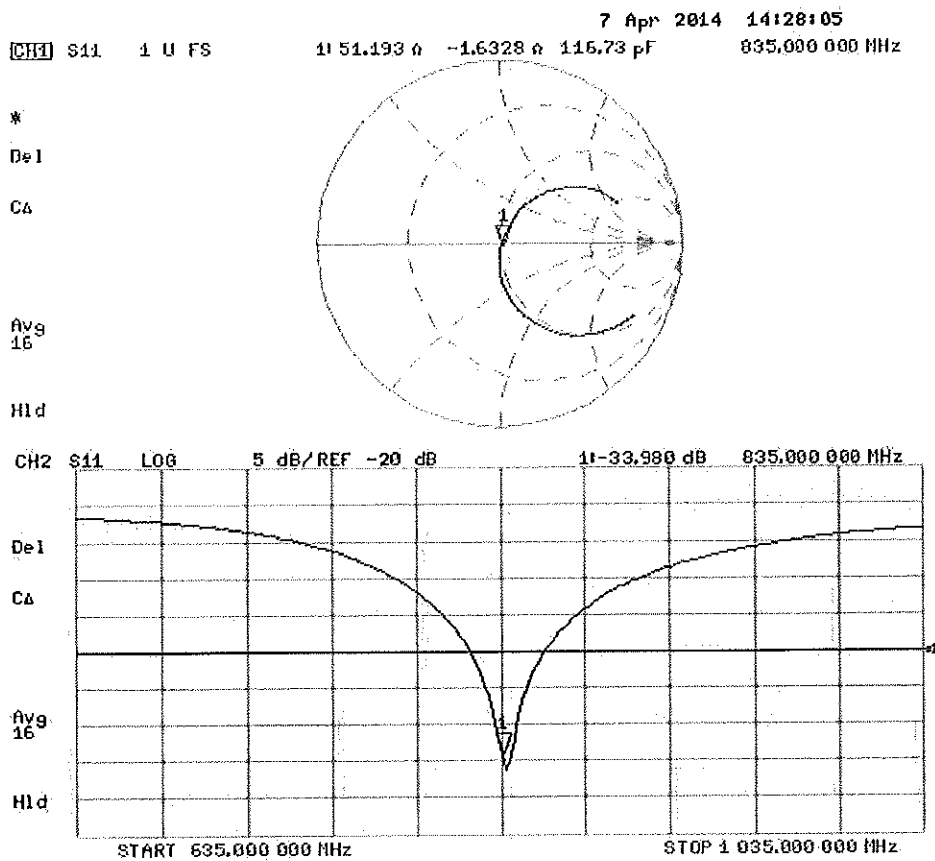

DASY5 Validation Report for Body TSL

Date: 07.04.2014

Test Laboratory: SPEAG, Zurich, Switzerland

DUT: Dipole 835 MHz; Type: D835V2; Serial: D835V2 - SN: 4d119

Communication System: UID 0 - CW; Frequency: 835 MHz

Medium parameters used: $f = 835$ MHz; $\sigma = 1.02$ S/m; $\epsilon_r = 53.6$; $\rho = 1000$ kg/m³

Phantom section: Flat Section

Measurement Standard: DASY5 (IEEE/IEC/ANSI C63.19-2007)

DASY52 Configuration:

- Probe: ES3DV3 - SN3205; ConvF(6.09, 6.09, 6.09); Calibrated: 30.12.2013;
- Sensor-Surface: 3mm (Mechanical Surface Detection)
- Electronics: DAE4 Sn601; Calibrated: 25.04.2013
- Phantom: Flat Phantom 4.9L; Type: QD000P49AA; Serial: 1001
- DASY52 52.8.7(1137); SEMCAD X 14.6.10(7164)

Dipole Calibration for Body Tissue/Pin=250 mW, d=15mm/Zoom Scan (7x7x7)/Cube 0:

Measurement grid: dx=5mm, dy=5mm, dz=5mm

Reference Value = 54.594 V/m; Power Drift = -0.01 dB

Peak SAR (extrapolated) = 3.61 W/kg

SAR(1 g) = 2.44 W/kg; SAR(10 g) = 1.59 W/kg

Maximum value of SAR (measured) = 2.85 W/kg

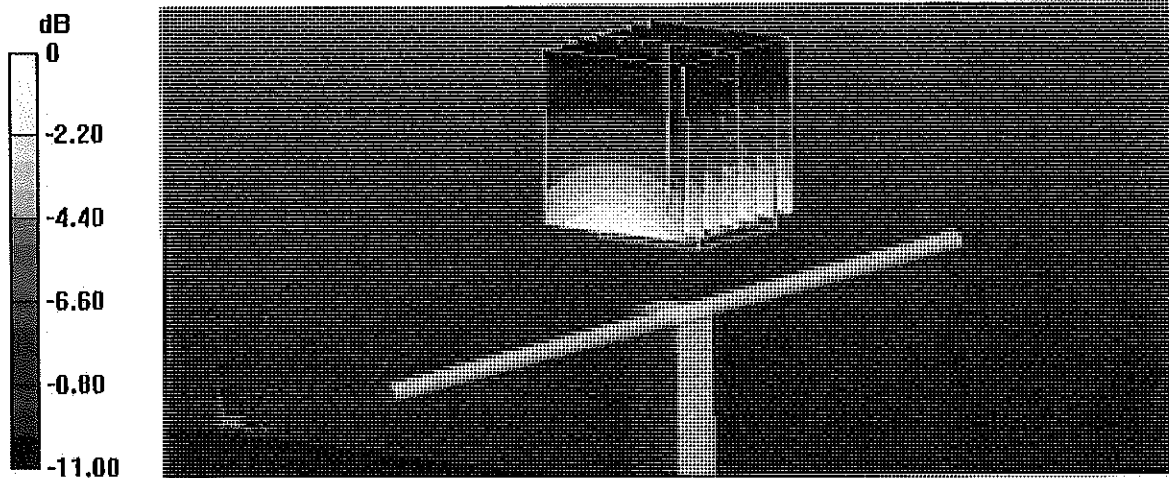

0 dB = 2.85 W/kg = 4.55 dBW/kg

Impedance Measurement Plot for Body TSL

7 Apr 2014 11:08:44
 [CH1] S11 1 U FS 1i 46.309 Ω -4.5078 Ω 42.203 pF 835.000 000 MHz

*
 Del
 CA
 Avg
 16
 H1d

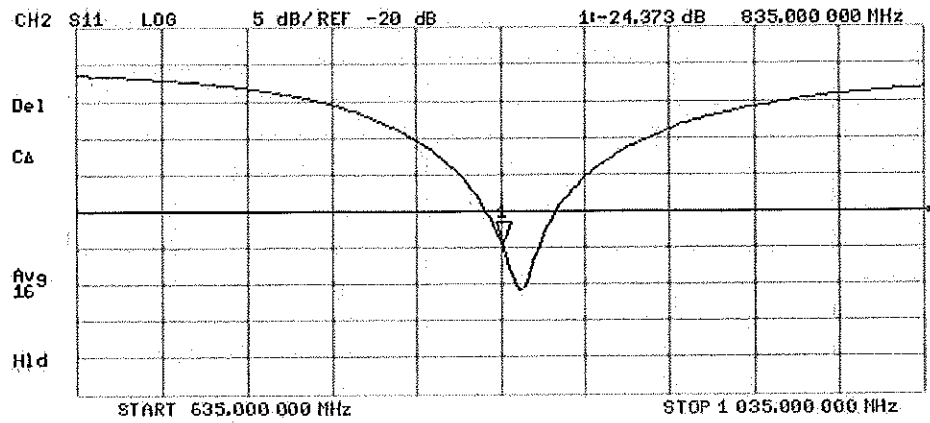
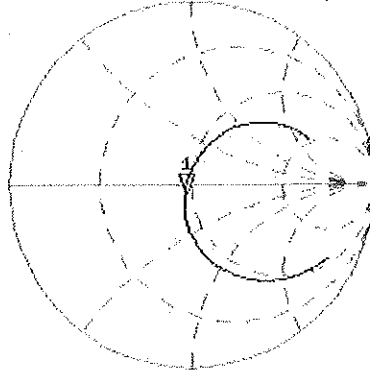



Accredited by the Swiss Accreditation Service (SAS)
The Swiss Accreditation Service is one of the signatories to the EA
Multilateral Agreement for the recognition of calibration certificates

Accreditation No.: **SCS 108**

Client **PC Test**

Certificate No: **D1765V2-1008_May14**

CALIBRATION CERTIFICATE

Object **D1765V2 - SN: 1008**

Calibration procedure(s) **QA CAL-05.v9
Calibration procedure for dipole validation kits above 700 MHz**

*CCV
6/2/14*

Calibration date: **May 07, 2014**

This calibration certificate documents the traceability to national standards, which realize the physical units of measurements (SI).
The measurements and the uncertainties with confidence probability are given on the following pages and are part of the certificate.

All calibrations have been conducted in the closed laboratory facility: environment temperature (22 ± 3)°C and humidity < 70%.

Calibration Equipment used (M&TE critical for calibration)

Primary Standards	ID #	Cal Date (Certificate No.)	Scheduled Calibration
Power meter EPM-442A	GB37480704	09-Oct-13 (No. 217-01827)	Oct-14
Power sensor HP 8481A	US37292783	09-Oct-13 (No. 217-01827)	Oct-14
Power sensor HP 8481A	MY41092317	09-Oct-13 (No. 217-01828)	Oct-14
Reference 20 dB Attenuator	SN: 5058 (20k)	03-Apr-14 (No. 217-01918)	Apr-15
Type-N mismatch combination	SN: 5047.2 / 06327	03-Apr-14 (No. 217-01921)	Apr-15
Reference Probe ES3DV3	SN: 3205	30-Dec-13 (No. ES3-3205_Dec13)	Dec-14
DAE4	SN: 601	30-Apr-14 (No. DAE4-601_Apr14)	Apr-15
Secondary Standards	ID #	Check Date (in house)	Scheduled Check
RF generator R&S SMT-06	100005	04-Aug-99 (in house check Oct-13)	In house check: Oct-16
Network Analyzer HP 8753E	US37390585 S4206	18-Oct-01 (in house check Oct-13)	In house check: Oct-14

Calibrated by: **Jeton Kastrati** (Name) / **Laboratory Technician** (Function) / *[Signature]* (Signature)

Approved by: **Katja Pokovic** (Name) / **Technical Manager** (Function) / *[Signature]* (Signature)

Issued: May 12, 2014

This calibration certificate shall not be reproduced except in full without written approval of the laboratory.



Accredited by the Swiss Accreditation Service (SAS)
The Swiss Accreditation Service is one of the signatories to the EA
Multilateral Agreement for the recognition of calibration certificates

Accreditation No.: **SCS 108**

Glossary:

TSL	tissue simulating liquid
ConvF	sensitivity in TSL / NORM x,y,z
N/A	not applicable or not measured

Calibration is Performed According to the Following Standards:

- a) IEEE Std 1528-2013, "IEEE Recommended Practice for Determining the Peak Spatial-Averaged Specific Absorption Rate (SAR) in the Human Head from Wireless Communications Devices: Measurement Techniques", June 2013
- b) IEC 62209-1, "Procedure to measure the Specific Absorption Rate (SAR) for hand-held devices used in close proximity to the ear (frequency range of 300 MHz to 3 GHz)", February 2005
- c) KDB 865664, "SAR Measurement Requirements for 100 MHz to 6 GHz"

Additional Documentation:

- d) DASY4/5 System Handbook

Methods Applied and Interpretation of Parameters:

- *Measurement Conditions:* Further details are available from the Validation Report at the end of the certificate. All figures stated in the certificate are valid at the frequency indicated.
- *Antenna Parameters with TSL:* The dipole is mounted with the spacer to position its feed point exactly below the center marking of the flat phantom section, with the arms oriented parallel to the body axis.
- *Feed Point Impedance and Return Loss:* These parameters are measured with the dipole positioned under the liquid filled phantom. The impedance stated is transformed from the measurement at the SMA connector to the feed point. The Return Loss ensures low reflected power. No uncertainty required.
- *Electrical Delay:* One-way delay between the SMA connector and the antenna feed point. No uncertainty required.
- *SAR measured:* SAR measured at the stated antenna input power.
- *SAR normalized:* SAR as measured, normalized to an input power of 1 W at the antenna connector.
- *SAR for nominal TSL parameters:* The measured TSL parameters are used to calculate the nominal SAR result.

The reported uncertainty of measurement is stated as the standard uncertainty of measurement multiplied by the coverage factor $k=2$, which for a normal distribution corresponds to a coverage probability of approximately 95%.

Measurement Conditions

DASY system configuration, as far as not given on page 1.

DASY Version	DASY5	V52.8.8
Extrapolation	Advanced Extrapolation	
Phantom	Modular Flat Phantom	
Distance Dipole Center - TSL	10 mm	with Spacer
Zoom Scan Resolution	dx, dy, dz = 5 mm	
Frequency	1750 MHz \pm 1 MHz	

Head TSL parameters

The following parameters and calculations were applied.

	Temperature	Permittivity	Conductivity
Nominal Head TSL parameters	22.0 °C	40.1	1.37 mho/m
Measured Head TSL parameters	(22.0 \pm 0.2) °C	39.0 \pm 6 %	1.36 mho/m \pm 6 %
Head TSL temperature change during test	< 0.5 °C	----	----

SAR result with Head TSL

SAR averaged over 1 cm ³ (1 g) of Head TSL	Condition	
SAR measured	250 mW input power	9.23 W/kg
SAR for nominal Head TSL parameters	normalized to 1W	36.9 W/kg \pm 17.0 % (k=2)

SAR averaged over 10 cm ³ (10 g) of Head TSL	condition	
SAR measured	250 mW input power	4.87 W/kg
SAR for nominal Head TSL parameters	normalized to 1W	19.5 W/kg \pm 16.5 % (k=2)

Body TSL parameters

The following parameters and calculations were applied.

	Temperature	Permittivity	Conductivity
Nominal Body TSL parameters	22.0 °C	53.4	1.49 mho/m
Measured Body TSL parameters	(22.0 \pm 0.2) °C	52.2 \pm 6 %	1.48 mho/m \pm 6 %
Body TSL temperature change during test	< 0.5 °C	----	----

SAR result with Body TSL

SAR averaged over 1 cm ³ (1 g) of Body TSL	Condition	
SAR measured	250 mW input power	9.41 W/kg
SAR for nominal Body TSL parameters	normalized to 1W	37.6 W/kg \pm 17.0 % (k=2)

SAR averaged over 10 cm ³ (10 g) of Body TSL	condition	
SAR measured	250 mW input power	5.02 W/kg
SAR for nominal Body TSL parameters	normalized to 1W	20.1 W/kg \pm 16.5 % (k=2)

Appendix

Antenna Parameters with Head TSL

Impedance, transformed to feed point	47.7 Ω - 6.1 j Ω
Return Loss	- 23.6 dB

Antenna Parameters with Body TSL

Impedance, transformed to feed point	43.7 Ω - 6.4 j Ω
Return Loss	- 20.4 dB

General Antenna Parameters and Design

Electrical Delay (one direction)	1.211 ns
----------------------------------	----------

After long term use with 100W radiated power, only a slight warming of the dipole near the feedpoint can be measured.

The dipole is made of standard semirigid coaxial cable. The center conductor of the feeding line is directly connected to the second arm of the dipole. The antenna is therefore short-circuited for DC-signals. On some of the dipoles, small end caps are added to the dipole arms in order to improve matching when loaded according to the position as explained in the "Measurement Conditions" paragraph. The SAR data are not affected by this change. The overall dipole length is still according to the Standard.

No excessive force must be applied to the dipole arms, because they might bend or the soldered connections near the feedpoint may be damaged.

Additional EUT Data

Manufactured by	SPEAG
Manufactured on	October 06, 2005

DASY5 Validation Report for Head TSL

Date: 07.05.2014

Test Laboratory: SPEAG, Zurich, Switzerland

DUT: Dipole 1765 MHz; Type: D1765V2; Serial: D1765V2 - SN: 1008

Communication System: UID 0 - CW; Frequency: 1750 MHz

Medium parameters used: $f = 1750$ MHz; $\sigma = 1.36$ S/m; $\epsilon_r = 39$; $\rho = 1000$ kg/m³

Phantom section: Flat Section

Measurement Standard: DASY5 (IEEE/IEC/ANSI C63.19-2007)

DASY52 Configuration:

- Probe: ES3DV3 - SN3205; ConvF(5.23, 5.23, 5.23); Calibrated: 30.12.2013;
- Sensor-Surface: 3mm (Mechanical Surface Detection)
- Electronics: DAE4 Sn601; Calibrated: 30.04.2014
- Phantom: Flat Phantom 5.0 (front); Type: QD000P50AA; Serial: 1001
- DASY52 52.8.8(1222); SEMCAD X 14.6.10(7331)

Dipole Calibration for Head Tissue/Pin=250 mW, d=10mm/Zoom Scan (7x7x7)/Cube 0:

Measurement grid: dx=5mm, dy=5mm, dz=5mm

Reference Value = 96.06 V/m; Power Drift = 0.01 dB

Peak SAR (extrapolated) = 16.7 W/kg

SAR(1 g) = 9.23 W/kg; SAR(10 g) = 4.87 W/kg

Maximum value of SAR (measured) = 11.7 W/kg

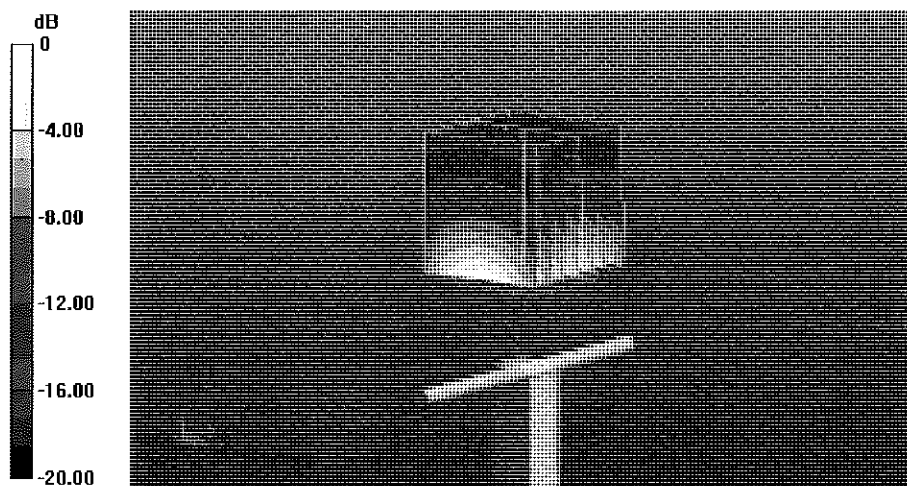

0 dB = 11.7 W/kg = 10.68 dBW/kg

Impedance Measurement Plot for Head TSL

7 May 2014 09:22:35

CH1 S11 1 U FS 1: 47.709 Ω -6.0566 Ω 15.016 pF 1 750.000 000 MHz

*
De1
C Δ
Avg
16
H1 d

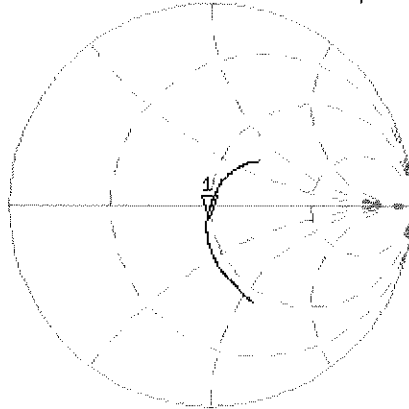

CH2 S11 LOG 5 dB/REF -20 dB 1:-23.588 dB 1 750.000 000 MHz

C Δ
Avg
16
H1 d

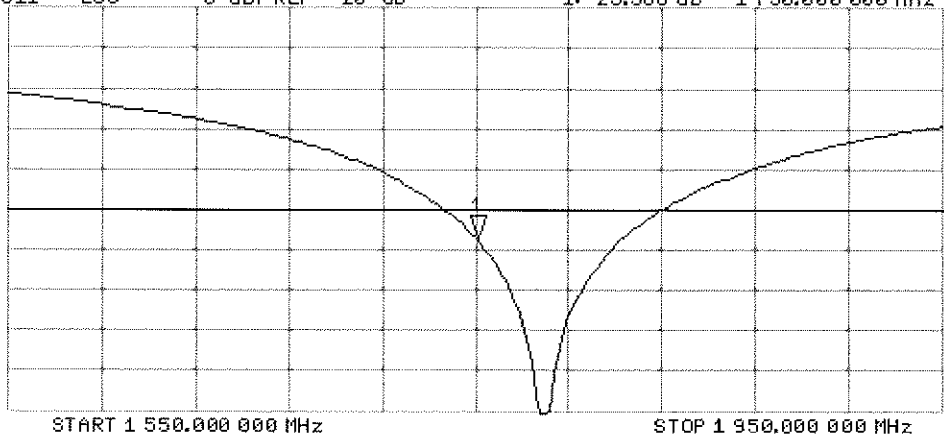

DASY5 Validation Report for Body TSL

Date: 07.05.2014

Test Laboratory: SPEAG, Zurich, Switzerland

DUT: Dipole 1765 MHz; Type: D1765V2; Serial: D1765V2 - SN: 1008

Communication System: UID 0 - CW; Frequency: 1750 MHz

Medium parameters used: $f = 1750$ MHz; $\sigma = 1.48$ S/m; $\epsilon_r = 52.2$; $\rho = 1000$ kg/m³

Phantom section: Flat Section

Measurement Standard: DASY5 (IEEE/IEC/ANSI C63.19-2007)

DASY52 Configuration:

- Probe: ES3DV3 - SN3205; ConvF(4.89, 4.89, 4.89); Calibrated: 30.12.2013;
- Sensor-Surface: 3mm (Mechanical Surface Detection)
- Electronics: DAE4 Sn601; Calibrated: 30.04.2014
- Phantom: Flat Phantom 5.0 (back); Type: QD000P50AA; Serial: 1002
- DASY52 52.8.8(1222); SEMCAD X 14.6.10(7331)

Dipole Calibration for Body Tissue/Pin=250 mW, d=10mm/Zoom Scan (7x7x7)/Cube 0:

Measurement grid: dx=5mm, dy=5mm, dz=5mm

Reference Value = 93.01 V/m; Power Drift = 0.00 dB

Peak SAR (extrapolated) = 16.3 W/kg

SAR(1 g) = 9.41 W/kg; SAR(10 g) = 5.02 W/kg

Maximum value of SAR (measured) = 11.8 W/kg

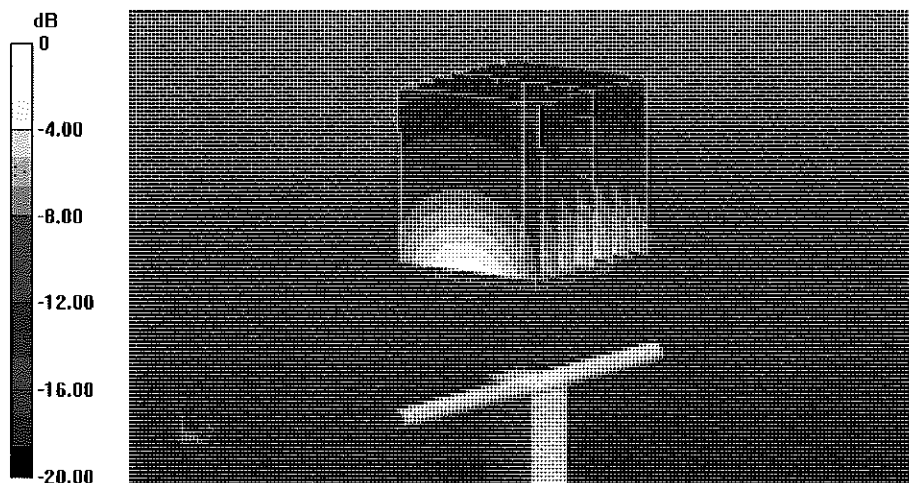

Impedance Measurement Plot for Body TSL

7 May 2014 09:21:55

CH1 S11 1 U FS 1: 43.727 \angle -6.3691 \angle 14.279 pF 1 750.000 000 MHz

*
De1
CA
Avg
16
H1d

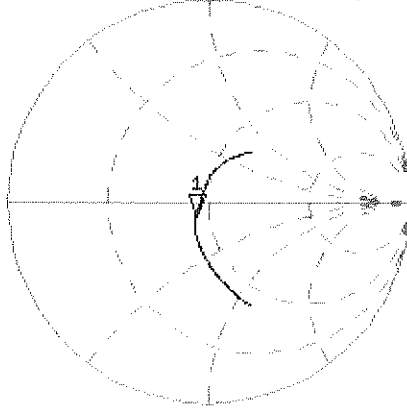

CH2 S11 LOG 5 dB/REF -20 dB 1:-20.428 dB 1 750.000 000 MHz

CA
Avg
16
H1d

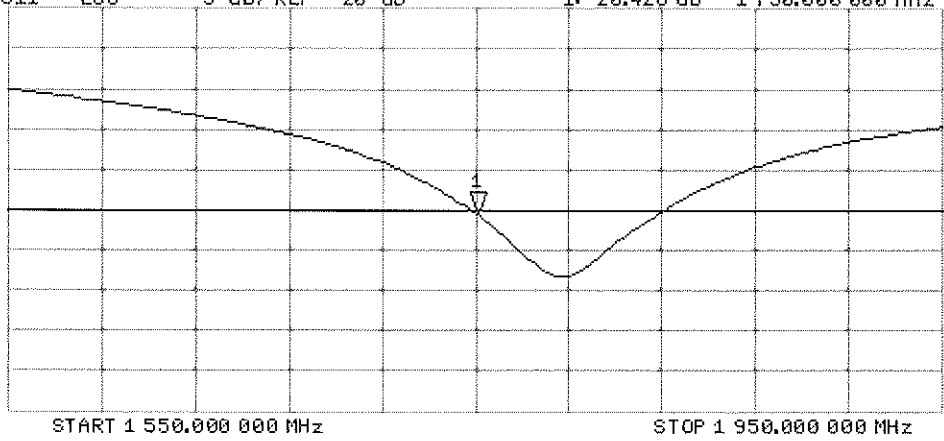



Accredited by the Swiss Accreditation Service (SAS)
The Swiss Accreditation Service is one of the signatories to the EA
Multilateral Agreement for the recognition of calibration certificates

Accreditation No.: **SCS 108**

Client **PC Test**

Certificate No: **D1900V2-5d149_Jul14**

CALIBRATION CERTIFICATE

Object **D1900V2 - SN: 5d149**

Calibration procedure(s) **QA CAL-05.v9
Calibration procedure for dipole validation kits above 700 MHz**

CC
11/5/14

Calibration date: **July 23, 2014**

This calibration certificate documents the traceability to national standards, which realize the physical units of measurements (SI).
The measurements and the uncertainties with confidence probability are given on the following pages and are part of the certificate.

All calibrations have been conducted in the closed laboratory facility: environment temperature (22 ± 3)°C and humidity < 70%.

Calibration Equipment used (M&TE critical for calibration)

Primary Standards	ID #	Cal Date (Certificate No.)	Scheduled Calibration
Power meter EPM-442A	GB37480704	09-Oct-13 (No. 217-01827)	Oct-14
Power sensor HP 8481A	US37292783	09-Oct-13 (No. 217-01827)	Oct-14
Power sensor HP 8481A	MY41092317	09-Oct-13 (No. 217-01828)	Oct-14
Reference 20 dB Attenuator	SN: 5058 (20k)	03-Apr-14 (No. 217-01918)	Apr-15
Type-N mismatch combination	SN: 5047.2 / 06327	03-Apr-14 (No. 217-01921)	Apr-15
Reference Probe ES3DV3	SN: 3205	30-Dec-13 (No. ES3-3205_Dec13)	Dec-14
DAE4	SN: 601	30-Apr-14 (No. DAE4-601_Apr14)	Apr-15
Secondary Standards	ID #	Check Date (In house)	Scheduled Check
RF generator R&S SMT-06	100005	04-Aug-99 (in house check Oct-13)	in house check: Oct-16
Network Analyzer HP 8753E	US37390585 S4206	18-Oct-01 (in house check Oct-13)	in house check: Oct-14

Calibrated by:	Name Jeton Kastrati	Function Laboratory Technician	Signature
Approved by:	Name Katja Pokovic	Technical Manager	

Issued: July 23, 2014

This calibration certificate shall not be reproduced except in full without written approval of the laboratory.



Accredited by the Swiss Accreditation Service (SAS)
The Swiss Accreditation Service is one of the signatories to the EA
Multilateral Agreement for the recognition of calibration certificates

Accreditation No.: **SCS 108**

Glossary:

TSL	tissue simulating liquid
ConvF	sensitivity in TSL / NORM x,y,z
N/A	not applicable or not measured

Calibration is Performed According to the Following Standards:

- a) IEEE Std 1528-2013, "IEEE Recommended Practice for Determining the Peak Spatial-Averaged Specific Absorption Rate (SAR) in the Human Head from Wireless Communications Devices: Measurement Techniques", June 2013
- b) IEC 62209-1, "Procedure to measure the Specific Absorption Rate (SAR) for hand-held devices used in close proximity to the ear (frequency range of 300 MHz to 3 GHz)", February 2005
- c) KDB 865664, "SAR Measurement Requirements for 100 MHz to 6 GHz"

Additional Documentation:

- d) DASY4/5 System Handbook

Methods Applied and Interpretation of Parameters:

- *Measurement Conditions:* Further details are available from the Validation Report at the end of the certificate. All figures stated in the certificate are valid at the frequency indicated.
- *Antenna Parameters with TSL:* The dipole is mounted with the spacer to position its feed point exactly below the center marking of the flat phantom section, with the arms oriented parallel to the body axis.
- *Feed Point Impedance and Return Loss:* These parameters are measured with the dipole positioned under the liquid filled phantom. The impedance stated is transformed from the measurement at the SMA connector to the feed point. The Return Loss ensures low reflected power. No uncertainty required.
- *Electrical Delay:* One-way delay between the SMA connector and the antenna feed point. No uncertainty required.
- *SAR measured:* SAR measured at the stated antenna input power.
- *SAR normalized:* SAR as measured, normalized to an input power of 1 W at the antenna connector.
- *SAR for nominal TSL parameters:* The measured TSL parameters are used to calculate the nominal SAR result.

The reported uncertainty of measurement is stated as the standard uncertainty of measurement multiplied by the coverage factor $k=2$, which for a normal distribution corresponds to a coverage probability of approximately 95%.

Measurement Conditions

DASY system configuration, as far as not given on page 1.

DASY Version	DASY5	V52.8.8
Extrapolation	Advanced Extrapolation	
Phantom	Modular Flat Phantom	
Distance Dipole Center - TSL	10 mm	with Spacer
Zoom Scan Resolution	dx, dy, dz = 5 mm	
Frequency	1900 MHz ± 1 MHz	

Head TSL parameters

The following parameters and calculations were applied.

	Temperature	Permittivity	Conductivity
Nominal Head TSL parameters	22.0 °C	40.0	1.40 mho/m
Measured Head TSL parameters	(22.0 ± 0.2) °C	39.5 ± 6 %	1.38 mho/m ± 6 %
Head TSL temperature change during test	< 0.5 °C	----	----

SAR result with Head TSL

SAR averaged over 1 cm ³ (1 g) of Head TSL	Condition	
SAR measured	250 mW input power	10.0 W/kg
SAR for nominal Head TSL parameters	normalized to 1W	40.2 W/kg ± 17.0 % (k=2)

SAR averaged over 10 cm ³ (10 g) of Head TSL	condition	
SAR measured	250 mW input power	5.24 W/kg
SAR for nominal Head TSL parameters	normalized to 1W	21.0 W/kg ± 16.5 % (k=2)

Body TSL parameters

The following parameters and calculations were applied.

	Temperature	Permittivity	Conductivity
Nominal Body TSL parameters	22.0 °C	53.3	1.52 mho/m
Measured Body TSL parameters	(22.0 ± 0.2) °C	52.5 ± 6 %	1.51 mho/m ± 6 %
Body TSL temperature change during test	< 0.5 °C	----	----

SAR result with Body TSL

SAR averaged over 1 cm ³ (1 g) of Body TSL	Condition	
SAR measured	250 mW input power	10.1 W/kg
SAR for nominal Body TSL parameters	normalized to 1W	40.4 W/kg ± 17.0 % (k=2)

SAR averaged over 10 cm ³ (10 g) of Body TSL	condition	
SAR measured	250 mW input power	5.33 W/kg
SAR for nominal Body TSL parameters	normalized to 1W	21.3 W/kg ± 16.5 % (k=2)

Appendix (Additional assessments outside the scope of SCS108)

Antenna Parameters with Head TSL

Impedance, transformed to feed point	52.6 Ω + 5.5 j Ω
Return Loss	- 24.6 dB

Antenna Parameters with Body TSL

Impedance, transformed to feed point	48.8 Ω + 6.1 j Ω
Return Loss	- 24.0 dB

General Antenna Parameters and Design

Electrical Delay (one direction)	1.197 ns
----------------------------------	----------

After long term use with 100W radiated power, only a slight warming of the dipole near the feedpoint can be measured.

The dipole is made of standard semirigid coaxial cable. The center conductor of the feeding line is directly connected to the second arm of the dipole. The antenna is therefore short-circuited for DC-signals. On some of the dipoles, small end caps are added to the dipole arms in order to improve matching when loaded according to the position as explained in the "Measurement Conditions" paragraph. The SAR data are not affected by this change. The overall dipole length is still according to the Standard.

No excessive force must be applied to the dipole arms, because they might bend or the soldered connections near the feedpoint may be damaged.

Additional EUT Data

Manufactured by	SPEAG
Manufactured on	March 11, 2011

DASY5 Validation Report for Head TSL

Date: 23.07.2014

Test Laboratory: SPEAG, Zurich, Switzerland

DUT: Dipole 1900 MHz; Type: D1900V2; Serial: D1900V2 - SN: 5d149

Communication System: UID 0 - CW; Frequency: 1900 MHz

Medium parameters used: $f = 1900 \text{ MHz}$; $\sigma = 1.38 \text{ S/m}$; $\epsilon_r = 39.5$; $\rho = 1000 \text{ kg/m}^3$

Phantom section: Flat Section

Measurement Standard: DASY5 (IEEE/IEC/ANSI C63.19-2011)

DASY52 Configuration:

- Probe: ES3DV3 - SN3205; ConvF(5.06, 5.06, 5.06); Calibrated: 30.12.2013;
- Sensor-Surface: 3mm (Mechanical Surface Detection)
- Electronics: DAE4 Sn601; Calibrated: 30.04.2014
- Phantom: Flat Phantom 5.0 (front); Type: QD000P50AA; Serial: 100I
- DASY52 52.8.8(1222); SEMCAD X 14.6.10(7331)

Dipole Calibration for Head Tissue/ $P_{in}=250 \text{ mW}$, $d=10\text{mm}$ /Zoom Scan (7x7x7)/Cube 0:

Measurement grid: $dx=5\text{mm}$, $dy=5\text{mm}$, $dz=5\text{mm}$

Reference Value = 98.92 V/m ; Power Drift = 0.02 dB

Peak SAR (extrapolated) = 18.4 W/kg

SAR(1 g) = 10 W/kg ; SAR(10 g) = 5.24 W/kg

Maximum value of SAR (measured) = 12.8 W/kg

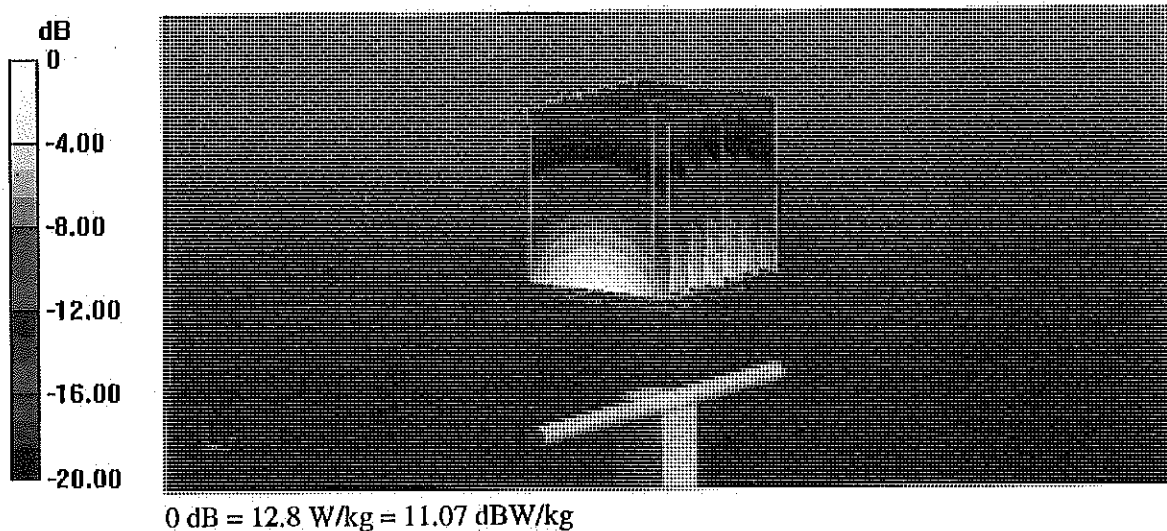

Impedance Measurement Plot for Head TSL

23 Jul 2014 10:46:05

CH1 S11 1 U FS 1: 52.600 Ω 5.4570 Ω 457.11 pF 1 900.000 000 MHz

*
Del
Cor
Avg
16
H1d

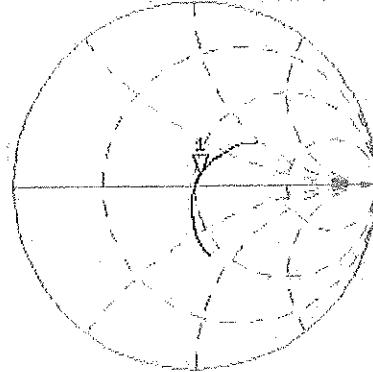

CH2 S11 LOG 5 dB/REF -20 dB 1: -24.600 dB 1 900.000 000 MHz

Cor
Avg
16
H1d

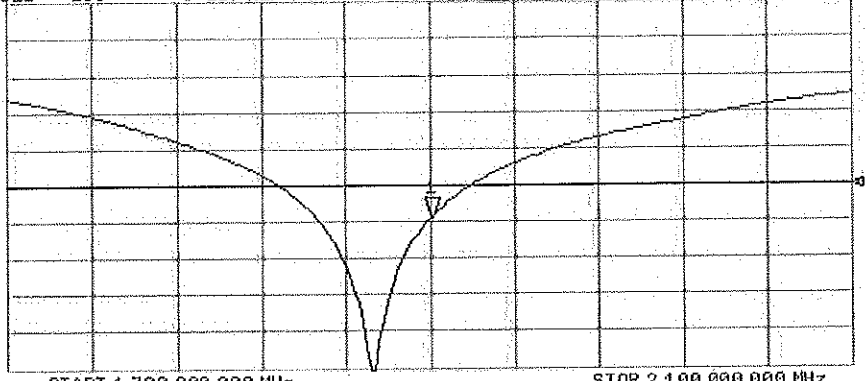

START 1 700.000 000 MHz

STOP 2 100.000 000 MHz

DASY5 Validation Report for Body TSL

Date: 23.07.2014

Test Laboratory: SPEAG, Zurich, Switzerland

DUT: Dipole 1900 MHz; Type: D1900V2; Serial: D1900V2 - SN: 5d149

Communication System: UID 0 - CW; Frequency: 1900 MHz

Medium parameters used: $f = 1900$ MHz; $\sigma = 1.51$ S/m; $\epsilon_r = 52.5$; $\rho = 1000$ kg/m³

Phantom section: Flat Section

Measurement Standard: DASY5 (IEEE/IEC/ANSI C63.19-2011)

DASY52 Configuration:

- Probe: ES3DV3 - SN3205; ConvF(4.76, 4.76, 4.76); Calibrated: 30.12.2013;
- Sensor-Surface: 3mm (Mechanical Surface Detection)
- Electronics: DAE4 Sn601; Calibrated: 30.04.2014
- Phantom: Flat Phantom 5.0 (back); Type: QD000P50AA; Serial: 1002
- DASY52 52.8.8(1222); SEMCAD X 14.6.10(7331)

Dipole Calibration for Body Tissue/Pin=250 mW, d=10mm/Zoom Scan (7x7x7)/Cube 0:

Measurement grid: dx=5mm, dy=5mm, dz=5mm

Reference Value = 95.83 V/m; Power Drift = -0.01 dB

Peak SAR (extrapolated) = 17.6 W/kg

SAR(1 g) = 10.1 W/kg; SAR(10 g) = 5.33 W/kg

Maximum value of SAR (measured) = 12.8 W/kg

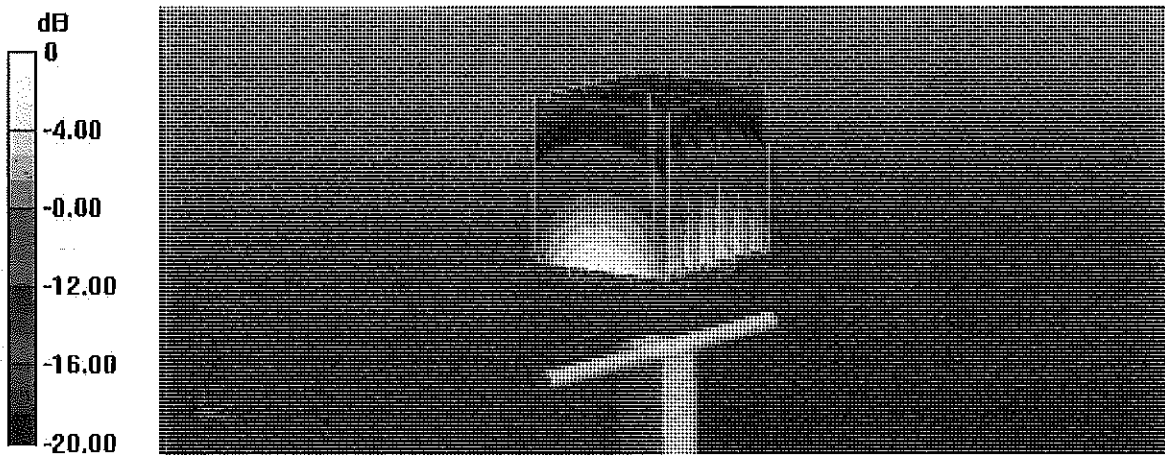

0 dB = 12.8 W/kg = 11.07 dBW/kg

Impedance Measurement Plot for Body TSL

23 Jul 2014 10:45:45

CH1 S11 1 U FS 1: 48.789 Ω 6.1426 Ω 514.54 pF 1 900.000 000 MHz

*
Del
Cor

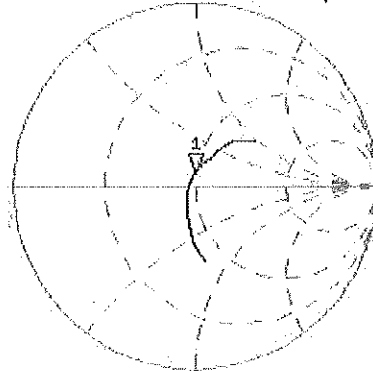

Avg
16
H1d

CH2 S11 LOG 5 dB/REF -20 dB 1: -23.974 dB 1 900.000 000 MHz

Cor
Avg
16
H1d

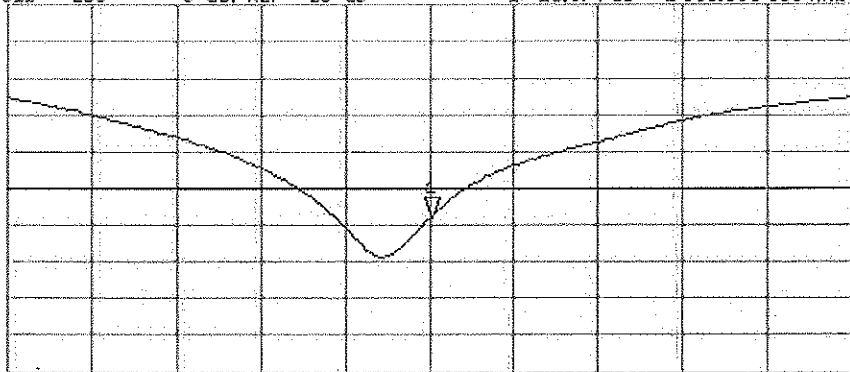



Accredited by the Swiss Accreditation Service (SAS)
The Swiss Accreditation Service is one of the signatories to the EA
Multilateral Agreement for the recognition of calibration certificates

Accreditation No.: **SCS 108**

Client **PC Test**

Certificate No: **D2450V2-719_Aug14**

CALIBRATION CERTIFICATE

Object **D2450V2 - SN: 719**

Calibration procedure(s) **QA CAL-05.v9
Calibration procedure for dipole validation kits above 700 MHz**

Calibration date: **August 11, 2014**

✓ KOK 9/8/14

This calibration certificate documents the traceability to national standards, which realize the physical units of measurements (SI).
The measurements and the uncertainties with confidence probability are given on the following pages and are part of the certificate.

All calibrations have been conducted in the closed laboratory facility: environment temperature (22 ± 3)°C and humidity < 70%.

Calibration Equipment used (M&TE critical for calibration)

Primary Standards	ID #	Cal Date (Certificate No.)	Scheduled Calibration
Power meter EPM-442A	GB37480704	09-Oct-13 (No. 217-01827)	Oct-14
Power sensor HP 8481A	US37292783	09-Oct-13 (No. 217-01827)	Oct-14
Power sensor HP 8481A	MY41092317	09-Oct-13 (No. 217-01828)	Oct-14
Reference 20 dB Attenuator	SN: 5058 (20k)	03-Apr-14 (No. 217-01918)	Apr-15
Type-N mismatch combination	SN: 5047.2 / 06327	03-Apr-14 (No. 217-01921)	Apr-15
Reference Probe ES3DV3	SN: 3205	30-Dec-13 (No. ES3-3205_Dec13)	Dec-14
DAE4	SN: 601	30-Apr-14 (No. DAE4-601_Apr14)	Apr-15
Secondary Standards	ID #	Check Date (in house)	Scheduled Check
RF generator R&S SMT-06	100005	04-Aug-99 (in house check Oct-13)	In house check: Oct-16
Network Analyzer HP 8753E	US37390585 S4206	18-Oct-01 (in house check Oct-13)	In house check: Oct-14

Calibrated by: **Michael Weber** Function: **Laboratory Technician** Signature: *M. Weber*

Approved by: **Katja Pokovic** Technical Manager *[Signature]*

Issued: August 12, 2014

This calibration certificate shall not be reproduced except in full without written approval of the laboratory.



Accredited by the Swiss Accreditation Service (SAS)
The Swiss Accreditation Service is one of the signatories to the EA
Multilateral Agreement for the recognition of calibration certificates

Accreditation No.: **SCS 108**

Glossary:

TSL	tissue simulating liquid
ConvF	sensitivity in TSL / NORM x,y,z
N/A	not applicable or not measured

Calibration is Performed According to the Following Standards:

- a) IEEE Std 1528-2013, "IEEE Recommended Practice for Determining the Peak Spatial-Averaged Specific Absorption Rate (SAR) in the Human Head from Wireless Communications Devices: Measurement Techniques", June 2013
- b) IEC 62209-1, "Procedure to measure the Specific Absorption Rate (SAR) for hand-held devices used in close proximity to the ear (frequency range of 300 MHz to 3 GHz)", February 2005
- c) KDB 865664, "SAR Measurement Requirements for 100 MHz to 6 GHz"

Additional Documentation:

- d) DASY4/5 System Handbook

Methods Applied and Interpretation of Parameters:

- *Measurement Conditions:* Further details are available from the Validation Report at the end of the certificate. All figures stated in the certificate are valid at the frequency indicated.
- *Antenna Parameters with TSL:* The dipole is mounted with the spacer to position its feed point exactly below the center marking of the flat phantom section, with the arms oriented parallel to the body axis.
- *Feed Point Impedance and Return Loss:* These parameters are measured with the dipole positioned under the liquid filled phantom. The impedance stated is transformed from the measurement at the SMA connector to the feed point. The Return Loss ensures low reflected power. No uncertainty required.
- *Electrical Delay:* One-way delay between the SMA connector and the antenna feed point. No uncertainty required.
- *SAR measured:* SAR measured at the stated antenna input power.
- *SAR normalized:* SAR as measured, normalized to an input power of 1 W at the antenna connector.
- *SAR for nominal TSL parameters:* The measured TSL parameters are used to calculate the nominal SAR result.

The reported uncertainty of measurement is stated as the standard uncertainty of measurement multiplied by the coverage factor $k=2$, which for a normal distribution corresponds to a coverage probability of approximately 95%.

Measurement Conditions

DASY system configuration, as far as not given on page 1.

DASY Version	DASY5	V52.8.8
Extrapolation	Advanced Extrapolation	
Phantom	Modular Flat Phantom	
Distance Dipole Center - TSL	10 mm	with Spacer
Zoom Scan Resolution	dx, dy, dz = 5 mm	
Frequency	2450 MHz \pm 1 MHz	

Head TSL parameters

The following parameters and calculations were applied.

	Temperature	Permittivity	Conductivity
Nominal Head TSL parameters	22.0 °C	39.2	1.80 mho/m
Measured Head TSL parameters	(22.0 \pm 0.2) °C	38.0 \pm 6 %	1.82 mho/m \pm 6 %
Head TSL temperature change during test	< 0.5 °C	----	----

SAR result with Head TSL

SAR averaged over 1 cm ³ (1 g) of Head TSL	Condition	
SAR measured	250 mW input power	13.2 W/kg
SAR for nominal Head TSL parameters	normalized to 1W	52.1 W/kg \pm 17.0 % (k=2)

SAR averaged over 10 cm ³ (10 g) of Head TSL	condition	
SAR measured	250 mW input power	6.09 W/kg
SAR for nominal Head TSL parameters	normalized to 1W	24.2 W/kg \pm 16.5 % (k=2)

Body TSL parameters

The following parameters and calculations were applied.

	Temperature	Permittivity	Conductivity
Nominal Body TSL parameters	22.0 °C	52.7	1.95 mho/m
Measured Body TSL parameters	(22.0 \pm 0.2) °C	50.5 \pm 6 %	2.02 mho/m \pm 6 %
Body TSL temperature change during test	< 0.5 °C	----	----

SAR result with Body TSL

SAR averaged over 1 cm ³ (1 g) of Body TSL	Condition	
SAR measured	250 mW input power	13.3 W/kg
SAR for nominal Body TSL parameters	normalized to 1W	51.8 W/kg \pm 17.0 % (k=2)

SAR averaged over 10 cm ³ (10 g) of Body TSL	condition	
SAR measured	250 mW input power	6.10 W/kg
SAR for nominal Body TSL parameters	normalized to 1W	24.0 W/kg \pm 16.5 % (k=2)

Appendix (Additional assessments outside the scope of SCS108)

Antenna Parameters with Head TSL

Impedance, transformed to feed point	54.9 Ω + 3.0 j Ω
Return Loss	- 25.2 dB

Antenna Parameters with Body TSL

Impedance, transformed to feed point	50.9 Ω + 5.8 j Ω
Return Loss	- 24.7 dB

General Antenna Parameters and Design

Electrical Delay (one direction)	1.149 ns
----------------------------------	----------

After long term use with 100W radiated power, only a slight warming of the dipole near the feedpoint can be measured.

The dipole is made of standard semirigid coaxial cable. The center conductor of the feeding line is directly connected to the second arm of the dipole. The antenna is therefore short-circuited for DC-signals. On some of the dipoles, small end caps are added to the dipole arms in order to improve matching when loaded according to the position as explained in the "Measurement Conditions" paragraph. The SAR data are not affected by this change. The overall dipole length is still according to the Standard.

No excessive force must be applied to the dipole arms, because they might bend or the soldered connections near the feedpoint may be damaged.

Additional EUT Data

Manufactured by	SPEAG
Manufactured on	September 10, 2002

DASY5 Validation Report for Head TSL

Date: 11.08.2014

Test Laboratory: SPEAG, Zurich, Switzerland

DUT: Dipole 2450 MHz; Type: D2450V2; Serial: D2450V2 - SN: 719

Communication System: UID 0 - CW; Frequency: 2450 MHz

Medium parameters used: $f = 2450$ MHz; $\sigma = 1.82$ S/m; $\epsilon_r = 38$; $\rho = 1000$ kg/m³

Phantom section: Flat Section

Measurement Standard: DASY5 (IEEE/IEC/ANSI C63.19-2011)

DASY52 Configuration:

- Probe: ES3DV3 - SN3205; ConvF(4.53, 4.53, 4.53); Calibrated: 30.12.2013;
- Sensor-Surface: 3mm (Mechanical Surface Detection)
- Electronics: DAE4 Sn601; Calibrated: 30.04.2014
- Phantom: Flat Phantom 5.0 (front); Type: QD000P50AA; Serial: 1001
- DASY52 52.8.8(1222); SEMCAD X 14.6.10(7331)

Dipole Calibration for Head Tissue/Pin=250 mW, d=10mm/Zoom Scan (7x7x7)/Cube 0:

Measurement grid: dx=5mm, dy=5mm, dz=5mm

Reference Value = 101.6 V/m; Power Drift = 0.03 dB

Peak SAR (extrapolated) = 27.5 W/kg

SAR(1 g) = 13.2 W/kg; SAR(10 g) = 6.09 W/kg

Maximum value of SAR (measured) = 17.4 W/kg

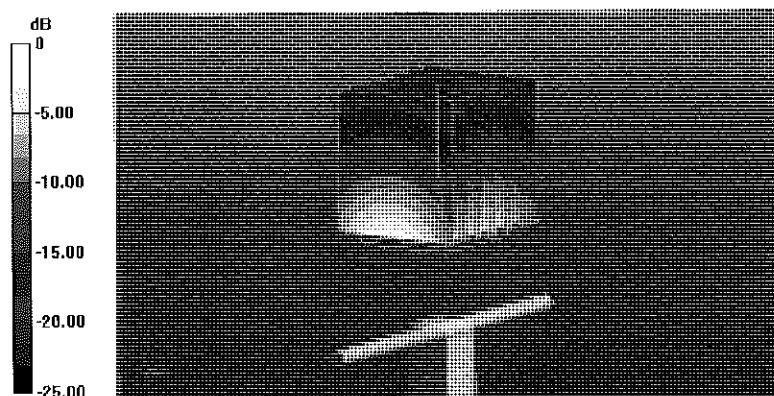

0 dB = 17.4 W/kg = 12.41 dBW/kg

Impedance Measurement Plot for Head TSL

11 Aug 2014 11:49:06

CH1 S11 1 U FS 1: 54.887 Ω 3.0391 Ω 197.42 pF 2 450.000 000 MHz

Del
C Δ

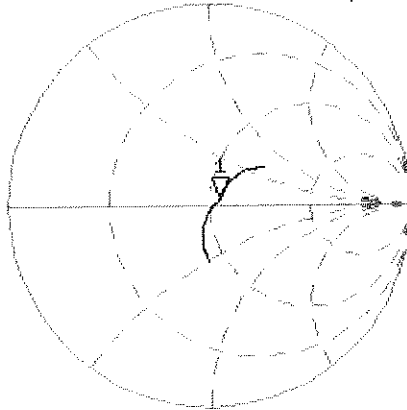

Avg
16

H1 d

CH2 S11 LOG 5 dB/REF -20 dB 1: -25.212 dB 2 450.000 000 MHz

C Δ

Avg
16

H1 d

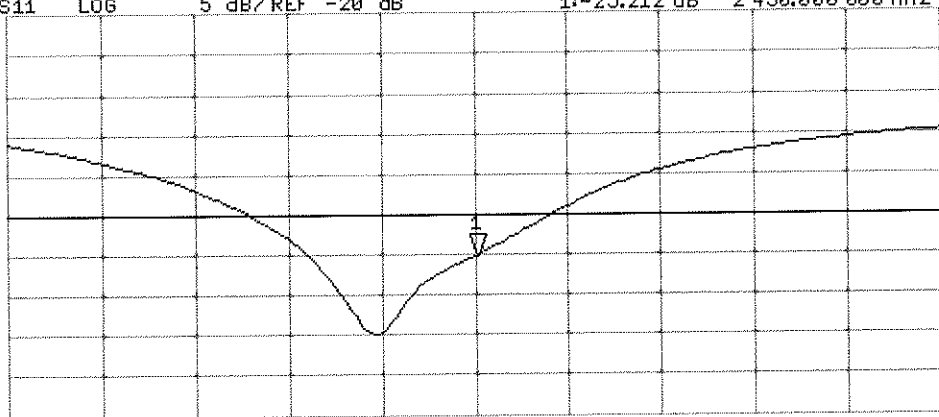

START 2 250.000 000 MHz

STOP 2 650.000 000 MHz

DASY5 Validation Report for Body TSL

Date: 11.08.2014

Test Laboratory: SPEAG, Zurich, Switzerland

DUT: Dipole 2450 MHz; Type: D2450V2; Serial: D2450V2 - SN: 719

Communication System: UID 0 - CW; Frequency: 2450 MHz

Medium parameters used: $f = 2450$ MHz; $\sigma = 2.02$ S/m; $\epsilon_r = 50.5$; $\rho = 1000$ kg/m³

Phantom section: Flat Section

Measurement Standard: DASY5 (IEEE/IEC/ANSI C63.19-2011)

DASY52 Configuration:

- Probe: ES3DV3 - SN3205; ConvF(4.35, 4.35, 4.35); Calibrated: 30.12.2013;
- Sensor-Surface: 3mm (Mechanical Surface Detection)
- Electronics: DAE4 Sn601; Calibrated: 30.04.2014
- Phantom: Flat Phantom 5.0 (back); Type: QD000P50AA; Serial: 1002
- DASY52 52.8.8(1222); SEMCAD X 14.6.10(7331)

Dipole Calibration for Body Tissue/Pin=250 mW, d=10mm/Zoom Scan (7x7x7)/Cube 0:

Measurement grid: dx=5mm, dy=5mm, dz=5mm

Reference Value = 96.08 V/m; Power Drift = -0.01 dB

Peak SAR (extrapolated) = 27.9 W/kg

SAR(1 g) = 13.3 W/kg; SAR(10 g) = 6.1 W/kg

Maximum value of SAR (measured) = 17.6 W/kg

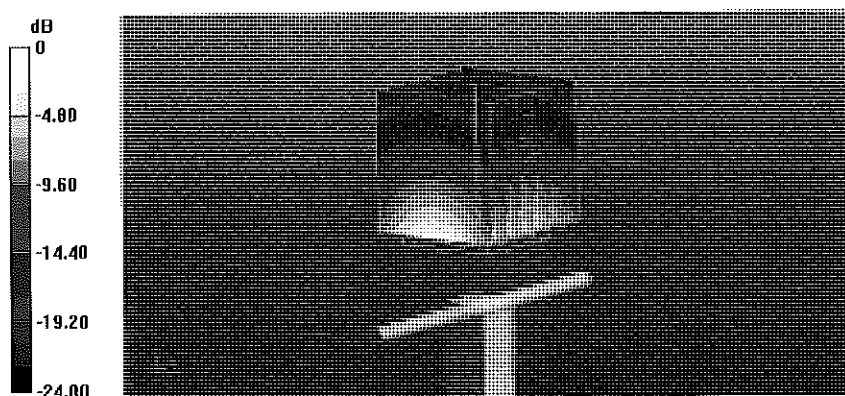

0 dB = 17.6 W/kg = 12.46 dBW/kg

Impedance Measurement Plot for Body TSL

11 Aug 2014 11:48:32

CH1 S11 1 U FS 1: 50.928 Δ 5.8223 Δ 378.22 pF 2 450.000 000 MHz

*
De1

CA

Avg
15

H1 d

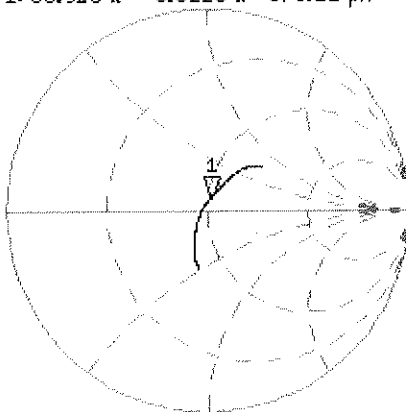

CH2 S11 LOG 5 dB/REF -20 dB 1:-24.679 dB 2 450.000 000 MHz

CA

Avg
15

H1 d

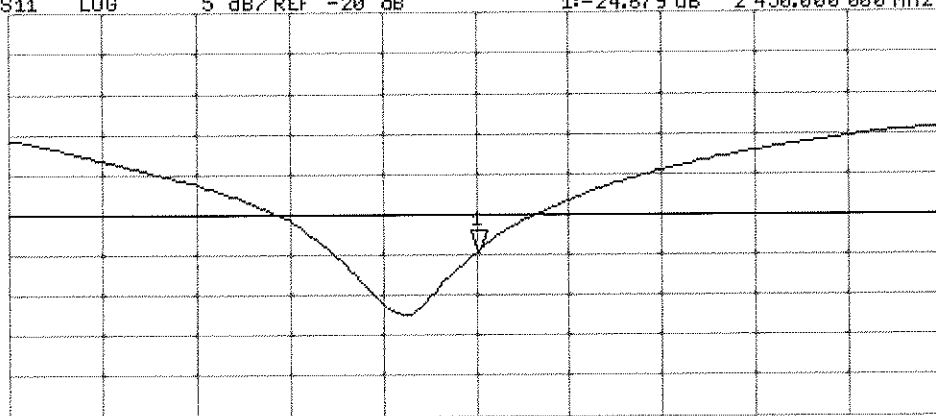

START 2 250.000 000 MHz

STOP 2 650.000 000 MHz

**Calibration Laboratory of
Schmid & Partner
Engineering AG**
Zeughausstrasse 43, 8004 Zurich, Switzerland



S Schweizerischer Kalibrierdienst
C Service suisse d'étalonnage
S Servizio svizzero di taratura
S Swiss Calibration Service

Accredited by the Swiss Accreditation Service (SAS)
The Swiss Accreditation Service is one of the signatories to the EA
Multilateral Agreement for the recognition of calibration certificates

Accreditation No.: **SCS 108**

Client **PC Test**

Certificate No: **D2600V2-1071_Oct14**

CALIBRATION CERTIFICATE

Object **D2600V2 - SN: 1071**

Calibration procedure(s) **QA CAL-05.v9
Calibration procedure for dipole validation kits above 700 MHz**

CC
11/11/14

Calibration date: **October 20, 2014**

This calibration certificate documents the traceability to national standards, which realize the physical units of measurements (SI).
The measurements and the uncertainties with confidence probability are given on the following pages and are part of the certificate.

All calibrations have been conducted in the closed laboratory facility: environment temperature (22 ± 3)°C and humidity < 70%.

Calibration Equipment used (M&TE critical for calibration)

Primary Standards	ID #	Cal Date (Certificate No.)	Scheduled Calibration
Power meter EPM-442A	GB37480704	07-Oct-14 (No. 217-02020)	Oct-15
Power sensor HP 8481A	US37292783	07-Oct-14 (No. 217-02020)	Oct-15
Power sensor HP 8481A	MY41092317	07-Oct-14 (No. 217-02021)	Oct-15
Reference 20 dB Attenuator	SN: 5058 (20k)	03-Apr-14 (No. 217-01918)	Apr-15
Type-N mismatch combination	SN: 5047.2 / 06327	03-Apr-14 (No. 217-01921)	Apr-15
Reference Probe ES3DV3	SN: 3205	30-Dec-13 (No. ES3-3205_Dec13)	Dec-14
DAE4	SN: 601	18-Aug-14 (No. DAE4-601_Aug14)	Aug-15
Secondary Standards	ID #	Check Date (In house)	Scheduled Check
RF generator R&S SMT-06	100005	04-Aug-99 (in house check Oct-13)	In house check: Oct-16
Network Analyzer HP 8753E	US37390585 S4206	18-Oct-01 (in house check Oct-14)	In house check: Oct-15

Calibrated by: **Michael Weber** Name: Michael Weber Function: Laboratory Technician

Signature
M. Weber

Approved by: **Katja Pokovic** Name: Katja Pokovic Technical Manager

Katja Pokovic

Issued: October 20, 2014

This calibration certificate shall not be reproduced except in full without written approval of the laboratory.

**Calibration Laboratory of
Schmid & Partner
Engineering AG**
Zeughausstrasse 43, 8004 Zurich, Switzerland



S Schweizerischer Kalibrierdienst
C Service suisse d'étalonnage
S Servizio svizzero di taratura
S Swiss Calibration Service

Accredited by the Swiss Accreditation Service (SAS)
The Swiss Accreditation Service is one of the signatories to the EA
Multilateral Agreement for the recognition of calibration certificates

Accreditation No.: **SCS 108**

Glossary:

TSL	tissue simulating liquid
ConvF	sensitivity in TSL / NORM x,y,z
N/A	not applicable or not measured

Calibration is Performed According to the Following Standards:

- IEEE Std 1528-2013, "IEEE Recommended Practice for Determining the Peak Spatial-Averaged Specific Absorption Rate (SAR) in the Human Head from Wireless Communications Devices: Measurement Techniques", June 2013
- IEC 62209-1, "Procedure to measure the Specific Absorption Rate (SAR) for hand-held devices used in close proximity to the ear (frequency range of 300 MHz to 3 GHz)", February 2005
- KDB 865664, "SAR Measurement Requirements for 100 MHz to 6 GHz"

Additional Documentation:

- DASY4/5 System Handbook

Methods Applied and Interpretation of Parameters:

- Measurement Conditions:* Further details are available from the Validation Report at the end of the certificate. All figures stated in the certificate are valid at the frequency indicated.
- Antenna Parameters with TSL:* The dipole is mounted with the spacer to position its feed point exactly below the center marking of the flat phantom section, with the arms oriented parallel to the body axis.
- Feed Point Impedance and Return Loss:* These parameters are measured with the dipole positioned under the liquid filled phantom. The impedance stated is transformed from the measurement at the SMA connector to the feed point. The Return Loss ensures low reflected power. No uncertainty required.
- Electrical Delay:* One-way delay between the SMA connector and the antenna feed point. No uncertainty required.
- SAR measured:* SAR measured at the stated antenna input power.
- SAR normalized:* SAR as measured, normalized to an input power of 1 W at the antenna connector.
- SAR for nominal TSL parameters:* The measured TSL parameters are used to calculate the nominal SAR result.

The reported uncertainty of measurement is stated as the standard uncertainty of measurement multiplied by the coverage factor $k=2$, which for a normal distribution corresponds to a coverage probability of approximately 95%.

Measurement Conditions

DASY system configuration, as far as not given on page 1.

DASY Version	DASY5	V52.8.8
Extrapolation	Advanced Extrapolation	
Phantom	Modular Flat Phantom	
Distance Dipole Center - TSL	10 mm	with Spacer
Zoom Scan Resolution	dx, dy, dz = 5 mm	
Frequency	2600 MHz \pm 1 MHz	

Head TSL parameters

The following parameters and calculations were applied.

	Temperature	Permittivity	Conductivity
Nominal Head TSL parameters	22.0 °C	39.0	1.96 mho/m
Measured Head TSL parameters	(22.0 \pm 0.2) °C	37.8 \pm 6 %	2.03 mho/m \pm 6 %
Head TSL temperature change during test	< 0.5 °C	----	----

SAR result with Head TSL

SAR averaged over 1 cm ³ (1 g) of Head TSL	Condition	
SAR measured	250 mW input power	14.7 W/kg
SAR for nominal Head TSL parameters	normalized to 1W	57.5 W/kg \pm 17.0 % (k=2)

SAR averaged over 10 cm ³ (10 g) of Head TSL	condition	
SAR measured	250 mW Input power	6.57 W/kg
SAR for nominal Head TSL parameters	normalized to 1W	25.9 W/kg \pm 16.5 % (k=2)

Body TSL parameters

The following parameters and calculations were applied.

	Temperature	Permittivity	Conductivity
Nominal Body TSL parameters	22.0 °C	52.5	2.16 mho/m
Measured Body TSL parameters	(22.0 \pm 0.2) °C	50.8 \pm 6 %	2.22 mho/m \pm 6 %
Body TSL temperature change during test	< 0.5 °C	----	----

SAR result with Body TSL

SAR averaged over 1 cm ³ (1 g) of Body TSL	Condition	
SAR measured	250 mW Input power	14.5 W/kg
SAR for nominal Body TSL parameters	normalized to 1W	56.9 W/kg \pm 17.0 % (k=2)

SAR averaged over 10 cm ³ (10 g) of Body TSL	condition	
SAR measured	250 mW Input power	6.43 W/kg
SAR for nominal Body TSL parameters	normalized to 1W	25.4 W/kg \pm 16.5 % (k=2)

Appendix (Additional assessments outside the scope of SCS108)

Antenna Parameters with Head TSL

Impedance, transformed to feed point	48.7 Ω - 5.2 j Ω
Return Loss	- 25.3 dB

Antenna Parameters with Body TSL

Impedance, transformed to feed point	45.9 Ω - 4.2 j Ω
Return Loss	- 24.2 dB

General Antenna Parameters and Design

Electrical Delay (one direction)	1.153 ns
----------------------------------	----------

After long term use with 100W radiated power, only a slight warming of the dipole near the feedpoint can be measured.

The dipole is made of standard semirigid coaxial cable. The center conductor of the feeding line is directly connected to the second arm of the dipole. The antenna is therefore short-circuited for DC-signals. On some of the dipoles, small end caps are added to the dipole arms in order to improve matching when loaded according to the position as explained in the "Measurement Conditions" paragraph. The SAR data are not affected by this change. The overall dipole length is still according to the Standard.

No excessive force must be applied to the dipole arms, because they might bend or the soldered connections near the feedpoint may be damaged.

Additional EUT Data

Manufactured by	SPEAG
Manufactured on	July 17, 2013

DASY5 Validation Report for Head TSL

Date: 20.10.2014

Test Laboratory: SPEAG, Zurich, Switzerland

DUT: Dipole 2600 MHz; Type: D2600V2; Serial: D2600V2 - SN: 1071

Communication System: UID 0 - CW; Frequency: 2600 MHz

Medium parameters used: $f = 2600$ MHz; $\sigma = 2.03$ S/m; $\epsilon_r = 37.8$; $\rho = 1000$ kg/m³

Phantom section: Flat Section

Measurement Standard: DASY5 (IEEE/IEC/ANSI C63.19-2011)

DASY52 Configuration:

- Probe: ES3DV3 - SN3205; ConvF(4.46, 4.46, 4.46); Calibrated: 30.12.2013;
- Sensor-Surface: 3mm (Mechanical Surface Detection)
- Electronics: DAE4 Sn601; Calibrated: 18.08.2014
- Phantom: Flat Phantom 5.0 (front); Type: QD000P50AA; Serial: 1001
- DASY52 52.8.8(1222); SEMCAD X 14.6.10(7331)

Dipole Calibration for Head Tissue/Pin=250 mW, d=10mm/Zoom Scan (7x7x7)/Cube 0:

Measurement grid: dx=5mm, dy=5mm, dz=5mm

Reference Value = 103.3 V/m; Power Drift = 0.02 dB

Peak SAR (extrapolated) = 31.0 W/kg

SAR(1 g) = 14.7 W/kg; SAR(10 g) = 6.57 W/kg

Maximum value of SAR (measured) = 19.7 W/kg

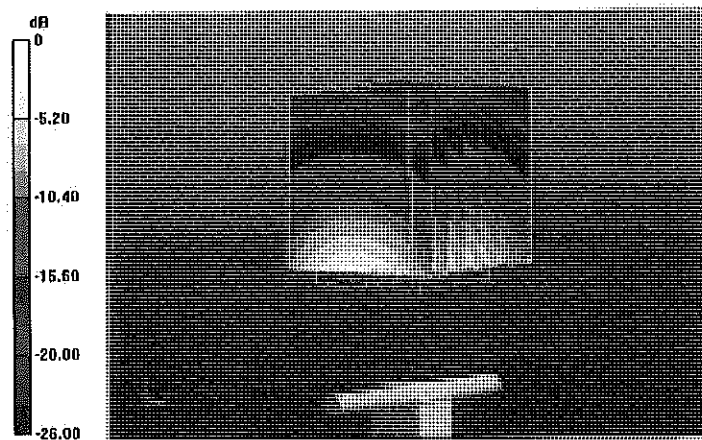

0 dB = 19.7 W/kg = 12.94 dBW/kg

Impedance Measurement Plot for Head TSL

20 Oct 2014 11:58:04

CH1 S11 1 U.FS 1: 48.721 Ω -5.2461 Ω 11.668 pF 2 600.000 000 MHz

*
De1
CA

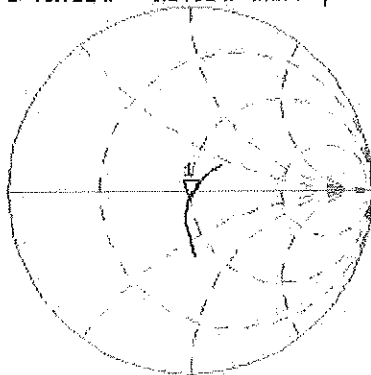

AVG
16

H1d

CH2 S11 LOG 5 dB/REF -20 dB 1:-25.254 dB 2 600.000 000 MHz

CA

AVG
16

H1d

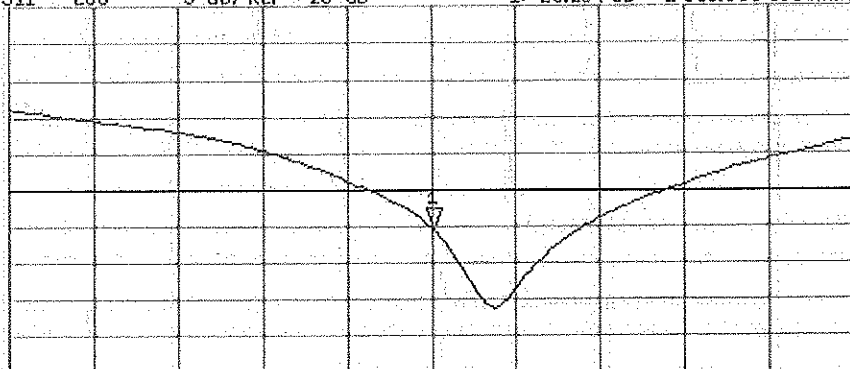

START 2 400.000 000 MHz

STOP 2 800.000 000 MHz

DASY5 Validation Report for Body TSL

Date: 20.10.2014

Test Laboratory: SPEAG, Zurich, Switzerland

DUT: Dipole 2600 MHz; Type: D2600V2; Serial: D2600V2 - SN: 1071

Communication System: UID 0 - CW; Frequency: 2600 MHz

Medium parameters used: $f = 2600$ MHz; $\sigma = 2.22$ S/m; $\epsilon_r = 50.8$; $\rho = 1000$ kg/m³

Phantom section: Flat Section

Measurement Standard: DASY5 (IEEE/IEC/ANSI C63.19-2011)

DASY52 Configuration:

- Probe: ES3DV3 - SN3205; ConvF(4.24, 4.24, 4.24); Calibrated: 30.12.2013;
- Sensor-Surface: 3mm (Mechanical Surface Detection)
- Electronics: DAE4 Sn601; Calibrated: 18.08.2014
- Phantom: Flat Phantom 5.0 (back); Type: QD000P50AA; Serial: 1002
- DASY52 52.8.8(1222); SEMCAD X 14.6.10(7331)

Dipole Calibration for Body Tissue/Pin=250 mW, d=10mm/Zoom Scan (7x7x7)/Cube 0:

Measurement grid: dx=5mm, dy=5mm, dz=5mm

Reference Value = 97.02 V/m; Power Drift = 0,00 dB

Peak SAR (extrapolated) = 31.0 W/kg

SAR(1 g) = 14.5 W/kg; SAR(10 g) = 6.43 W/kg

Maximum value of SAR (measured) = 19.3 W/kg

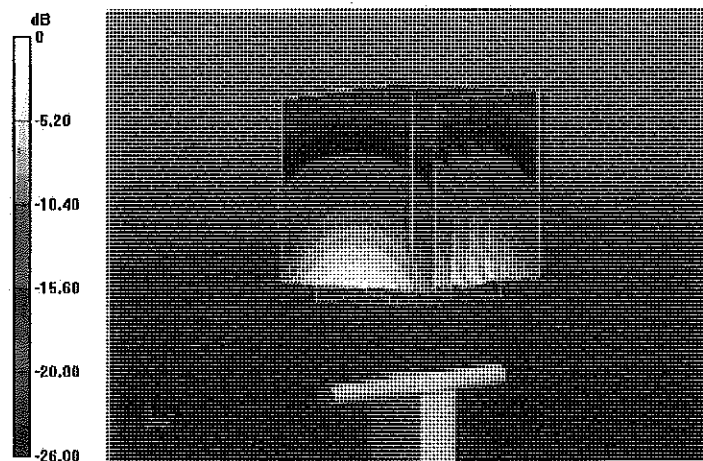

0 dB = 19.3 W/kg = 12.86 dBW/kg

Impedance Measurement Plot for Body TSL

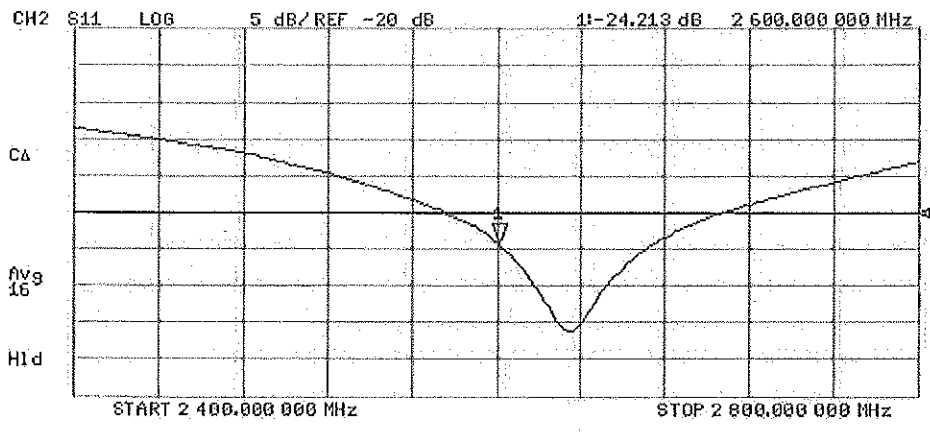
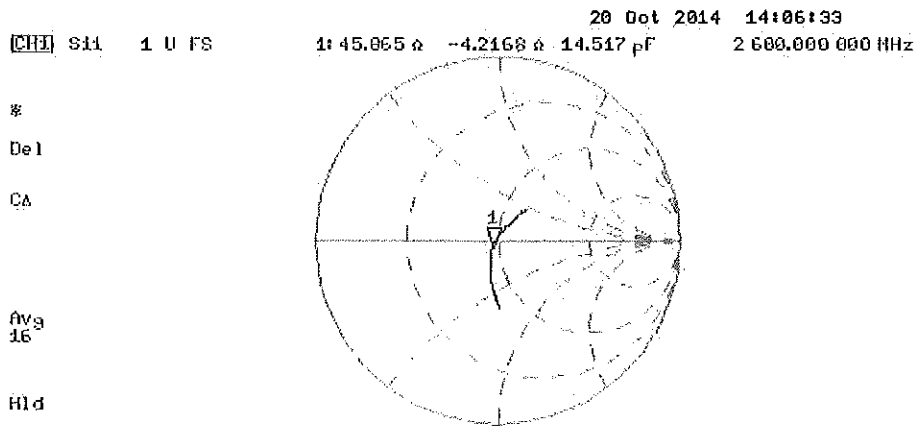



Accredited by the Swiss Accreditation Service (SAS)
The Swiss Accreditation Service is one of the signatories to the EA
Multilateral Agreement for the recognition of calibration certificates

Accreditation No.: **SCS 108**

Client **PC Test**

Certificate No: **D5GHzV2-1191_Sep14**

CALIBRATION CERTIFICATE

Object **D5GHzV2 - SN:1191**

Calibration procedure(s) **QA CAL-22.v2
Calibration procedure for dipole validation kits between 3-6 GHz**

*CC
11/14*

Calibration date: **September 25, 2014**

This calibration certificate documents the traceability to national standards, which realize the physical units of measurements (SI).
The measurements and the uncertainties with confidence probability are given on the following pages and are part of the certificate.

All calibrations have been conducted in the closed laboratory facility: environment temperature (22 ± 3)°C and humidity < 70%.

Calibration Equipment used (M&TE critical for calibration)

Primary Standards	ID #	Cal Date (Certificate No.)	Scheduled Calibration
Power meter EPM-442A	GB37480704	09-Oct-13 (No. 217-01827)	Oct-14
Power sensor HP 8481A	US37292783	09-Oct-13 (No. 217-01827)	Oct-14
Power sensor HP 8481A	MY41092317	09-Oct-13 (No. 217-01828)	Oct-14
Reference 20 dB Attenuator	SN: 5058 (20k)	03-Apr-14 (No. 217-01918)	Apr-15
Type-N mismatch combination	SN: 5047.2 / 06327	03-Apr-14 (No. 217-01921)	Apr-15
Reference Probe EX3DV4	SN: 3503	30-Dec-13 (No. EX3-3503_Dec13)	Dec-14
DAE4	SN: 601	18-Aug-14 (No. DAE4-601_Aug14)	Aug-15
Secondary Standards	ID #	Check Date (in house)	Scheduled Check
RF generator R&S SMT-06	100005	04-Aug-99 (in house check Oct-13)	In house check: Oct-16
Network Analyzer HP 8753E	US37390585 S4206	18-Oct-01 (in house check Oct-13)	In house check: Oct-14

Calibrated by: **Claudio Leubler** Name: Claudio Leubler Function: Laboratory Technician

Signature

Approved by: **Katja Pokovic** Name: Katja Pokovic Technical Manager

Issued: September 25, 2014

This calibration certificate shall not be reproduced except in full without written approval of the laboratory.

**Calibration Laboratory of
Schmid & Partner
Engineering AG**
Zeughausstrasse 43, 8004 Zurich, Switzerland



S Schweizerischer Kalibrierdienst
C Service suisse d'étalonnage
S Servizio svizzero di taratura
S Swiss Calibration Service

Accreditation No.: **SCS 108**

Accredited by the Swiss Accreditation Service (SAS)
The Swiss Accreditation Service is one of the signatories to the EA
Multilateral Agreement for the recognition of calibration certificates

Glossary:

TSL	tissue simulating liquid
ConvF	sensitivity in TSL / NORM x,y,z
N/A	not applicable or not measured

Calibration is Performed According to the Following Standards:

- IEC 62209-2, "Evaluation of Human Exposure to Radio Frequency Fields from Handheld and Body-Mounted Wireless Communication Devices in the Frequency Range of 30 MHz to 6 GHz: Human models, Instrumentation, and Procedures"; Part 2: "Procedure to determine the Specific Absorption Rate (SAR) for including accessories and multiple transmitters", March 2010
- KDB 865664, "SAR Measurement Requirements for 100 MHz to 6 GHz"
- IEEE Std 1528-2013, "IEEE Recommended Practice for Determining the Peak Spatial-Averaged Specific Absorption Rate (SAR) in the Human Head from Wireless Communications Devices: Measurement Techniques", June 2013

Additional Documentation:

- DASY4/5 System Handbook

Methods Applied and Interpretation of Parameters:

- Measurement Conditions:* Further details are available from the Validation Report at the end of the certificate. All figures stated in the certificate are valid at the frequency indicated.
- Antenna Parameters with TSL:* The dipole is mounted with the spacer to position its feed point exactly below the center marking of the flat phantom section, with the arms oriented parallel to the body axis.
- Feed Point Impedance and Return Loss:* These parameters are measured with the dipole positioned under the liquid filled phantom. The impedance stated is transformed from the measurement at the SMA connector to the feed point. The Return Loss ensures low reflected power. No uncertainty required.
- Electrical Delay:* One-way delay between the SMA connector and the antenna feed point. No uncertainty required.
- SAR measured:* SAR measured at the stated antenna input power.
- SAR normalized:* SAR as measured, normalized to an input power of 1 W at the antenna connector.
- SAR for nominal TSL parameters:* The measured TSL parameters are used to calculate the nominal SAR result.

The reported uncertainty of measurement is stated as the standard uncertainty of measurement multiplied by the coverage factor $k=2$, which for a normal distribution corresponds to a coverage probability of approximately 95%.

Measurement Conditions

DASY system configuration, as far as not given on page 1.

DASY Version	DASY5	V52.8.8
Extrapolation	Advanced Extrapolation	
Phantom	Modular Flat Phantom V5.0	
Distance Dipole Center - TSL	10 mm	with Spacer
Zoom Scan Resolution	dx, dy = 4.0 mm, dz = 1.4 mm	Graded Ratio = 1.4 (Z direction)
Frequency	5200 MHz ± 1 MHz 5300 MHz ± 1 MHz 5500 MHz ± 1 MHz 5600 MHz ± 1 MHz 5800 MHz ± 1 MHz	

Head TSL parameters at 5200 MHz

The following parameters and calculations were applied.

	Temperature	Permittivity	Conductivity
Nominal Head TSL parameters	22.0 °C	36.0	4.66 mho/m
Measured Head TSL parameters	(22.0 ± 0.2) °C	34.9 ± 6 %	4.54 mho/m ± 6 %
Head TSL temperature change during test	< 0.5 °C	----	----

SAR result with Head TSL at 5200 MHz

SAR averaged over 1 cm ³ (1 g) of Head TSL	Condition	
SAR measured	100 mW input power	8.17 W/kg
SAR for nominal Head TSL parameters	normalized to 1W	81.1 W/kg ± 19.9 % (k=2)

SAR averaged over 10 cm ³ (10 g) of Head TSL	condition	
SAR measured	100 mW input power	2.33 W/kg
SAR for nominal Head TSL parameters	normalized to 1W	23.1 W/kg ± 19.5 % (k=2)

Head TSL parameters at 5300 MHz

The following parameters and calculations were applied.

	Temperature	Permittivity	Conductivity
Nominal Head TSL parameters	22.0 °C	35.9	4.76 mho/m
Measured Head TSL parameters	(22.0 ± 0.2) °C	34.8 ± 6 %	4.64 mho/m ± 6 %
Head TSL temperature change during test	< 0.5 °C	----	----

SAR result with Head TSL at 5300 MHz

SAR averaged over 1 cm ³ (1 g) of Head TSL	Condition	
SAR measured	100 mW input power	8.64 W/kg
SAR for nominal Head TSL parameters	normalized to 1W	85.8 W / kg ± 19.9 % (k=2)

SAR averaged over 10 cm ³ (10 g) of Head TSL	condition	
SAR measured	100 mW input power	2.47 W/kg
SAR for nominal Head TSL parameters	normalized to 1W	24.5 W/kg ± 19.5 % (k=2)

Head TSL parameters at 5500 MHz

The following parameters and calculations were applied.

	Temperature	Permittivity	Conductivity
Nominal Head TSL parameters	22.0 °C	35.6	4.96 mho/m
Measured Head TSL parameters	(22.0 ± 0.2) °C	34.5 ± 6 %	4.83 mho/m ± 6 %
Head TSL temperature change during test	< 0.5 °C	----	----

SAR result with Head TSL at 5500 MHz

SAR averaged over 1 cm ³ (1 g) of Head TSL	Condition	
SAR measured	100 mW input power	8.93 W/kg
SAR for nominal Head TSL parameters	normalized to 1W	88.6 W/kg ± 19.9 % (k=2)

SAR averaged over 10 cm ³ (10 g) of Head TSL	condition	
SAR measured	100 mW input power	2.54 W/kg
SAR for nominal Head TSL parameters	normalized to 1W	25.2 W/kg ± 19.5 % (k=2)

Head TSL parameters at 5600 MHz

The following parameters and calculations were applied.

	Temperature	Permittivity	Conductivity
Nominal Head TSL parameters	22.0 °C	35.5	5.07 mho/m
Measured Head TSL parameters	(22.0 ± 0.2) °C	34.4 ± 6 %	4.93 mho/m ± 6 %
Head TSL temperature change during test	< 0.5 °C	----	----

SAR result with Head TSL at 5600 MHz

SAR averaged over 1 cm ³ (1 g) of Head TSL	Condition	
SAR measured	100 mW input power	8.76 W/kg
SAR for nominal Head TSL parameters	normalized to 1W	86.9 W/kg ± 19.9 % (k=2)

SAR averaged over 10 cm ³ (10 g) of Head TSL	condition	
SAR measured	100 mW input power	2.49 W/kg
SAR for nominal Head TSL parameters	normalized to 1W	24.7 W/kg ± 19.5 % (k=2)

Head TSL parameters at 5800 MHz

The following parameters and calculations were applied.

	Temperature	Permittivity	Conductivity
Nominal Head TSL parameters	22.0 °C	35.3	5.27 mho/m
Measured Head TSL parameters	(22.0 ± 0.2) °C	34.1 ± 6 %	5.14 mho/m ± 6 %
Head TSL temperature change during test	< 0.5 °C	----	----

SAR result with Head TSL at 5800 MHz

SAR averaged over 1 cm ³ (1 g) of Head TSL	Condition	
SAR measured	100 mW input power	8.30 W/kg
SAR for nominal Head TSL parameters	normalized to 1W	82.3 W/kg ± 19.9 % (k=2)

SAR averaged over 10 cm ³ (10 g) of Head TSL	condition	
SAR measured	100 mW input power	2.35 W/kg
SAR for nominal Head TSL parameters	normalized to 1W	23.3 W/kg ± 19.5 % (k=2)

Body TSL parameters at 5200 MHz

The following parameters and calculations were applied.

	Temperature	Permittivity	Conductivity
Nominal Body TSL parameters	22.0 °C	49.0	5.30 mho/m
Measured Body TSL parameters	(22.0 ± 0.2) °C	47.1 ± 6 %	5.40 mho/m ± 6 %
Body TSL temperature change during test	< 0.5 °C	----	----

SAR result with Body TSL at 5200 MHz

SAR averaged over 1 cm ³ (1 g) of Body TSL	Condition	
SAR measured	100 mW input power	7.84 W/kg
SAR for nominal Body TSL parameters	normalized to 1W	77.8 W/kg ± 19.9 % (k=2)

SAR averaged over 10 cm ³ (10 g) of Body TSL	condition	
SAR measured	100 mW input power	2.18 W/kg
SAR for nominal Body TSL parameters	normalized to 1W	21.6 W/kg ± 19.5 % (k=2)

Body TSL parameters at 5300 MHz

The following parameters and calculations were applied.

	Temperature	Permittivity	Conductivity
Nominal Body TSL parameters	22.0 °C	48.9	5.42 mho/m
Measured Body TSL parameters	(22.0 ± 0.2) °C	46.9 ± 6 %	5.53 mho/m ± 6 %
Body TSL temperature change during test	< 0.5 °C	----	----

SAR result with Body TSL at 5300 MHz

SAR averaged over 1 cm ³ (1 g) of Body TSL	Condition	
SAR measured	100 mW input power	8.05 W/kg
SAR for nominal Body TSL parameters	normalized to 1W	79.9 W/kg ± 19.9 % (k=2)

SAR averaged over 10 cm ³ (10 g) of Body TSL	condition	
SAR measured	100 mW input power	2.25 W/kg
SAR for nominal Body TSL parameters	normalized to 1W	22.3 W/kg ± 19.5 % (k=2)

Body TSL parameters at 5500 MHz

The following parameters and calculations were applied.

	Temperature	Permittivity	Conductivity
Nominal Body TSL parameters	22.0 °C	48.6	5.65 mho/m
Measured Body TSL parameters	(22.0 ± 0.2) °C	46.6 ± 6 %	5.79 mho/m ± 6 %
Body TSL temperature change during test	< 0.5 °C	----	----

SAR result with Body TSL at 5500 MHz

SAR averaged over 1 cm ³ (1 g) of Body TSL	Condition	
SAR measured	100 mW input power	8.37 W/kg
SAR for nominal Body TSL parameters	normalized to 1W	83.1 W/kg ± 19.9 % (k=2)

SAR averaged over 10 cm ³ (10 g) of Body TSL	condition	
SAR measured	100 mW input power	2.32 W/kg
SAR for nominal Body TSL parameters	normalized to 1W	23.0 W/kg ± 19.5 % (k=2)

Body TSL parameters at 5600 MHz

The following parameters and calculations were applied.

	Temperature	Permittivity	Conductivity
Nominal Body TSL parameters	22.0 °C	48.5	5.77 mho/m
Measured Body TSL parameters	(22.0 ± 0.2) °C	46.4 ± 6 %	5.93 mho/m ± 6 %
Body TSL temperature change during test	< 0.5 °C	----	----

SAR result with Body TSL at 5600 MHz

SAR averaged over 1 cm ³ (1 g) of Body TSL	Condition	
SAR measured	100 mW input power	8.48 W/kg
SAR for nominal Body TSL parameters	normalized to 1W	84.1 W/kg ± 19.9 % (k=2)

SAR averaged over 10 cm ³ (10 g) of Body TSL	condition	
SAR measured	100 mW input power	2.35 W/kg
SAR for nominal Body TSL parameters	normalized to 1W	23.3 W/kg ± 19.5 % (k=2)

Body TSL parameters at 5800 MHz

The following parameters and calculations were applied.

	Temperature	Permittivity	Conductivity
Nominal Body TSL parameters	22.0 °C	48.2	6.00 mho/m
Measured Body TSL parameters	(22.0 ± 0.2) °C	46.1 ± 6 %	6.21 mho/m ± 6 %
Body TSL temperature change during test	< 0.5 °C	----	----

SAR result with Body TSL at 5800 MHz

SAR averaged over 1 cm ³ (1 g) of Body TSL	Condition	
SAR measured	100 mW input power	7.86 W/kg
SAR for nominal Body TSL parameters	normalized to 1W	78.0 W/kg ± 19.9 % (k=2)

SAR averaged over 10 cm ³ (10 g) of Body TSL	condition	
SAR measured	100 mW input power	2.17 W/kg
SAR for nominal Body TSL parameters	normalized to 1W	21.5 W/kg ± 19.5 % (k=2)

Appendix (Additional assessments outside the scope of SCS108)

Antenna Parameters with Head TSL at 5200 MHz

Impedance, transformed to feed point	51.8 Ω - 9.9 j Ω
Return Loss	- 20.1 dB

Antenna Parameters with Head TSL at 5300 MHz

Impedance, transformed to feed point	54.5 Ω - 1.5 j Ω
Return Loss	- 26.8 dB

Antenna Parameters with Head TSL at 5500 MHz

Impedance, transformed to feed point	49.6 Ω - 2.0 j Ω
Return Loss	- 33.9 dB

Antenna Parameters with Head TSL at 5600 MHz

Impedance, transformed to feed point	56.5 Ω - 4.4 j Ω
Return Loss	- 22.7 dB

Antenna Parameters with Head TSL at 5800 MHz

Impedance, transformed to feed point	56.6 Ω + 4.4 j Ω
Return Loss	- 22.6 dB

Antenna Parameters with Body TSL at 5200 MHz

Impedance, transformed to feed point	51.9 Ω - 8.1 j Ω
Return Loss	- 21.8 dB

Antenna Parameters with Body TSL at 5300 MHz

Impedance, transformed to feed point	54.5 Ω + 0.1 j Ω
Return Loss	- 27.3 dB

Antenna Parameters with Body TSL at 5500 MHz

Impedance, transformed to feed point	50.2 Ω - 0.6 j Ω
Return Loss	- 43.8 dB

Antenna Parameters with Body TSL at 5600 MHz

Impedance, transformed to feed point	57.5 Ω - 3.2 j Ω
Return Loss	- 22.4 dB

Antenna Parameters with Body TSL at 5800 MHz

Impedance, transformed to feed point	57.2 Ω + 5.2 j Ω
Return Loss	- 21.7 dB

General Antenna Parameters and Design

Electrical Delay (one direction)	1.202 ns
----------------------------------	----------

After long term use with 100W radiated power, only a slight warming of the dipole near the feedpoint can be measured.

The dipole is made of standard semirigid coaxial cable. The center conductor of the feeding line is directly connected to the second arm of the dipole. The antenna is therefore short-circuited for DC-signals. On some of the dipoles, small end caps are added to the dipole arms in order to improve matching when loaded according to the position as explained in the "Measurement Conditions" paragraph. The SAR data are not affected by this change. The overall dipole length is still according to the Standard.

No excessive force must be applied to the dipole arms, because they might bend or the soldered connections near the feedpoint may be damaged.

Additional EUT Data

Manufactured by	SPEAG
Manufactured on	April 01, 2014

DASY5 Validation Report for Head TSL

Date: 25.09.2014

Test Laboratory: SPEAG, Zurich, Switzerland

DUT: Dipole 5GHz; Type: D5GHzV2; Serial: D5GHzV2 - SN:1191

Communication System: UID 0 - CW; Frequency: 5200 MHz, Frequency: 5300 MHz, Frequency: 5500 MHz, Frequency: 5600 MHz, Frequency: 5800 MHz

Medium parameters used: $f = 5200$ MHz; $\sigma = 4.54$ S/m; $\epsilon_r = 34.9$; $\rho = 1000$ kg/m³

Medium parameters used: $f = 5300$ MHz; $\sigma = 4.64$ S/m; $\epsilon_r = 34.8$; $\rho = 1000$ kg/m³

Medium parameters used: $f = 5500$ MHz; $\sigma = 4.83$ S/m; $\epsilon_r = 34.5$; $\rho = 1000$ kg/m³

Medium parameters used: $f = 5600$ MHz; $\sigma = 4.93$ S/m; $\epsilon_r = 34.4$; $\rho = 1000$ kg/m³

Medium parameters used: $f = 5800$ MHz; $\sigma = 5.14$ S/m; $\epsilon_r = 34.1$; $\rho = 1000$ kg/m³

Phantom section: Flat Section

Measurement Standard: DASY5 (IBEE/IEC/ANSI C63.19-2011)

DASY52 Configuration:

- Probe: EX3DV4 - SN3503; ConvF(5.52, 5.52, 5.52); Calibrated: 30.12.2013, ConvF(5.2, 5.2, 5.2); Calibrated: 30.12.2013, ConvF(5.01, 5.01, 5.01); Calibrated: 30.12.2013, ConvF(4.86, 4.86, 4.86); Calibrated: 30.12.2013, ConvF(4.91, 4.91, 4.91); Calibrated: 30.12.2013;
- Sensor-Surface: 1.4mm (Mechanical Surface Detection)
- Electronics: DAE4 Sn601; Calibrated: 18.08.2014
- Phantom: Flat Phantom 5.0 (front); Type: QD000P50AA; Serial: 1001
- DASY52 52.8.8(1222); SEMCAD X 14.6.10(7331)

Dipole Calibration for Head Tissue/Pin=100mW, dist=10mm, f=5200 MHz/Zoom Scan,

dist=1.4mm (8x8x7)/Cube 0: Measurement grid: dx=4mm, dy=4mm, dz=1.4mm

Reference Value = 65.20 V/m; Power Drift = 0.04 dB

Peak SAR (extrapolated) = 30.0 W/kg

SAR(1 g) = 8.17 W/kg; SAR(10 g) = 2.33 W/kg

Maximum value of SAR (measured) = 18.5 W/kg

Dipole Calibration for Head Tissue/Pin=100mW, dist=10mm, f=5300 MHz/Zoom Scan,

dist=1.4mm (8x8x7)/Cube 0: Measurement grid: dx=4mm, dy=4mm, dz=1.4mm

Reference Value = 65.90 V/m; Power Drift = 0.09 dB

Peak SAR (extrapolated) = 32.7 W/kg

SAR(1 g) = 8.64 W/kg; SAR(10 g) = 2.47 W/kg

Maximum value of SAR (measured) = 19.8 W/kg

Dipole Calibration for Head Tissue/Pin=100mW, dist=10mm, f=5500 MHz/Zoom Scan,

dist=1.4mm (8x8x7)/Cube 0: Measurement grid: dx=4mm, dy=4mm, dz=1.4mm

Reference Value = 65.91 V/m; Power Drift = 0.09 dB

Peak SAR (extrapolated) = 35.3 W/kg

SAR(1 g) = 8.93 W/kg; SAR(10 g) = 2.54 W/kg

Maximum value of SAR (measured) = 20.9 W/kg

Dipole Calibration for Head Tissue/Pin=100mW, dist=10mm, f=5600 MHz/Zoom Scan, dist=1.4mm (8x8x7)/Cube 0: Measurement grid: dx=4mm, dy=4mm, dz=1.4mm

Reference Value = 65.29 V/m; Power Drift = 0.07 dB

Peak SAR (extrapolated) = 34.8 W/kg

SAR(1 g) = 8.76 W/kg; SAR(10 g) = 2.49 W/kg

Maximum value of SAR (measured) = 20.7 W/kg

Dipole Calibration for Head Tissue/Pin=100mW, dist=10mm, f=5800 MHz/Zoom Scan, dist=1.4mm (8x8x7)/Cube 0: Measurement grid: dx=4mm, dy=4mm, dz=1.4mm

Reference Value = 62.74 V/m; Power Drift = 0.06 dB

Peak SAR (extrapolated) = 34.4 W/kg

SAR(1 g) = 8.3 W/kg; SAR(10 g) = 2.35 W/kg

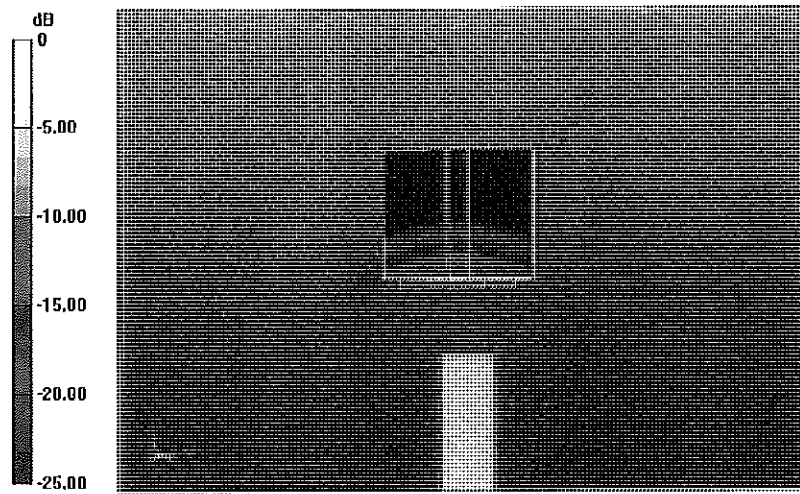

0 dB = 19.8 W/kg = 12.97 dBW/kg

Impedance Measurement Plot for Head TSL

25 Sep 2014 11:07:52

CH1 S11 1 U FS 1: 51.911 Ω -9.9180 Ω 3.0860 pF 5 200.000 000 MHz

*
Del
Cor
Avg
0
H1d

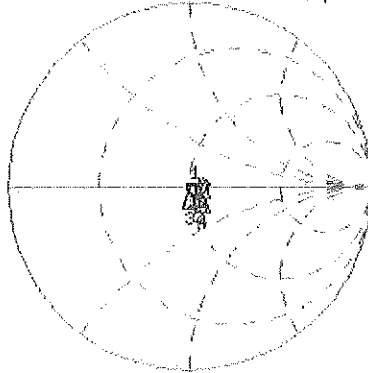

CH1 Markers

- 2: 54.518 Ω
-1.5078 Ω
5.30000 GHz
- 3: 49.566 Ω
-1.9707 Ω
5.50000 GHz
- 4: 56.516 Ω
-4.3633 Ω
5.60000 GHz
- 5: 56.555 Ω
4.3904 Ω
5.80000 GHz

CH2 S11 LOG 5 dB/REF -20 dB 1:-20.126 dB 5 200.000 000 MHz

Cor
Avg
0
H1d

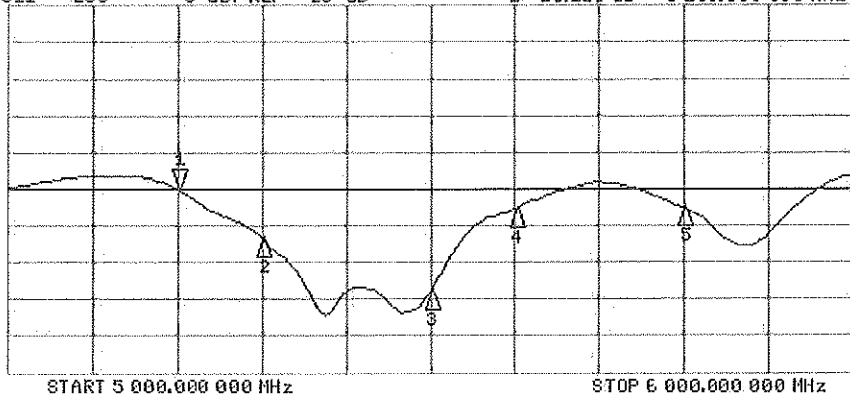

CH2 Markers

- 2: -26.825 dB
5.30000 GHz
- 3: -33.870 dB
5.50000 GHz
- 4: -22.660 dB
5.60000 GHz
- 5: -22.611 dB
5.80000 GHz

DASY5 Validation Report for Body TSL

Date: 24.09.2014

Test Laboratory: SPEAG, Zurich, Switzerland

DUT: Dipole 5GHz; Type: D5GHzV2; Serial: D5GHzV2 - SN:1191

Communication System: UID 0 - CW; Frequency: 5200 MHz, Frequency: 5300 MHz, Frequency: 5500 MHz, Frequency: 5600 MHz, Frequency: 5800 MHz

Medium parameters used: $f = 5200$ MHz; $\sigma = 5.4$ S/m; $\epsilon_r = 47.1$; $\rho = 1000$ kg/m³

Medium parameters used: $f = 5300$ MHz; $\sigma = 5.53$ S/m; $\epsilon_r = 46.9$; $\rho = 1000$ kg/m³

Medium parameters used: $f = 5500$ MHz; $\sigma = 5.79$ S/m; $\epsilon_r = 46.6$; $\rho = 1000$ kg/m³

Medium parameters used: $f = 5600$ MHz; $\sigma = 5.93$ S/m; $\epsilon_r = 46.4$; $\rho = 1000$ kg/m³

Medium parameters used: $f = 5800$ MHz; $\sigma = 6.21$ S/m; $\epsilon_r = 46.1$; $\rho = 1000$ kg/m³

Phantom section: Flat Section

Measurement Standard: DASY5 (IEBE/IEC/ANSI C63.19-2011)

DASY52 Configuration:

- Probe: EX3DV4 - SN3503; ConvF(5.01, 5.01, 5.01); Calibrated: 30.12.2013, ConvF(4.76, 4.76, 4.76); Calibrated: 30.12.2013, ConvF(4.52, 4.52, 4.52); Calibrated: 30.12.2013, ConvF(4.3, 4.3, 4.3); Calibrated: 30.12.2013, ConvF(4.47, 4.47, 4.47); Calibrated: 30.12.2013;
- Sensor-Surface: 1.4mm (Mechanical Surface Detection)
- Electronics: DAE4 Sn601; Calibrated: 18.08.2014
- Phantom: Flat Phantom 5.0 (back); Type: QD000P50AA; Serial: 1002
- DASY52 52.8.8(1222); SEMCAD X 14.6.10(7331)

Dipole Calibration for Body Tissue/Pin=100mW, dist=10mm, f=5200 MHz/Zoom Scan, dist=1.4mm (8x8x7)/Cube 0: Measurement grid: dx=4mm, dy=4mm, dz=1.4mm

Reference Value = 60.46 V/m; Power Drift = 0.02 dB

Peak SAR (extrapolated) = 30.7 W/kg

SAR(1 g) = 7.84 W/kg; SAR(10 g) = 2.18 W/kg

Maximum value of SAR (measured) = 18.5 W/kg

Dipole Calibration for Body Tissue/Pin=100mW, dist=10mm, f=5300 MHz/Zoom Scan, dist=1.4mm (8x8x7)/Cube 0: Measurement grid: dx=4mm, dy=4mm, dz=1.4mm

Reference Value = 60.42 V/m; Power Drift = 0.03 dB

Peak SAR (extrapolated) = 32.1 W/kg

SAR(1 g) = 8.05 W/kg; SAR(10 g) = 2.25 W/kg

Maximum value of SAR (measured) = 19.1 W/kg

Dipole Calibration for Body Tissue/Pin=100mW, dist=10mm, f=5500 MHz/Zoom Scan, dist=1.4mm (8x8x7)/Cube 0: Measurement grid: dx=4mm, dy=4mm, dz=1.4mm

Reference Value = 60.44 V/m; Power Drift = 0.02 dB

Peak SAR (extrapolated) = 35.8 W/kg

SAR(1 g) = 8.37 W/kg; SAR(10 g) = 2.32 W/kg

Maximum value of SAR (measured) = 20.4 W/kg

Dipole Calibration for Body Tissue/Pin=100mW, dist=10mm, f=5600 MHz/Zoom Scan, dist=1.4mm (8x8x7)/Cube 0: Measurement grid: dx=4mm, dy=4mm, dz=1.4mm
Reference Value = 60.44 V/m; Power Drift = 0.01 dB
Peak SAR (extrapolated) = 37.0 W/kg
SAR(1 g) = 8.48 W/kg; SAR(10 g) = 2.35 W/kg
Maximum value of SAR (measured) = 20.9 W/kg

Dipole Calibration for Body Tissue/Pin=100mW, dist=10mm, f=5800 MHz/Zoom Scan, dist=1.4mm (8x8x7)/Cube 0: Measurement grid: dx=4mm, dy=4mm, dz=1.4mm
Reference Value = 56.69 V/m; Power Drift = 0.01 dB
Peak SAR (extrapolated) = 36.4 W/kg
SAR(1 g) = 7.86 W/kg; SAR(10 g) = 2.17 W/kg
Maximum value of SAR (measured) = 19.7 W/kg

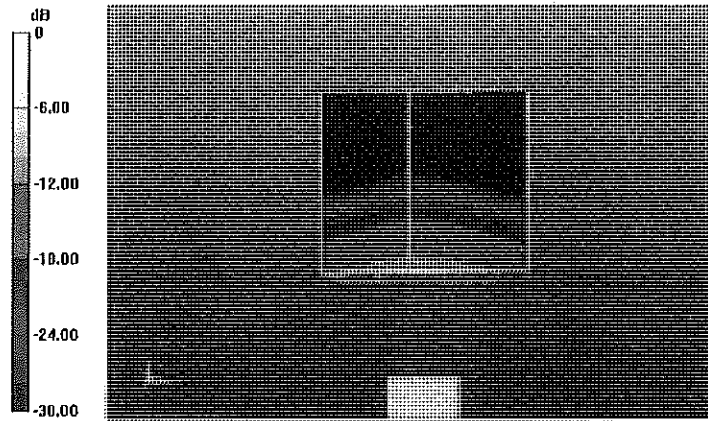

0 dB = 19.7 W/kg = 12.94 dBW/kg

Impedance Measurement Plot for Body TSL

24 Sep 2014 11:05:50

[CH1] S11 1 U FS 1: 51.867 Ω -8.0566 Ω 3.7989 pF 5 200.000 000 MHz

Del
Cor
Avg
16
H1d

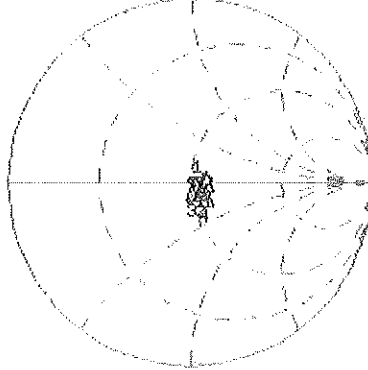

CH1 Markers

- 2: 54.531 Ω
0.1015 Ω
5.30000 GHz
- 3: 50.207 Ω
-613.28 pF
5.50000 GHz
- 4: 57.480 Ω
-3.1563 Ω
5.60000 GHz
- 5: 57.150 Ω
5.1934 Ω
5.80000 GHz

CH2 S11 LOG 5 dB/REF -20 dB 1: -21.835 dB 5 200.000 000 MHz

Cor
Avg
16
H1d

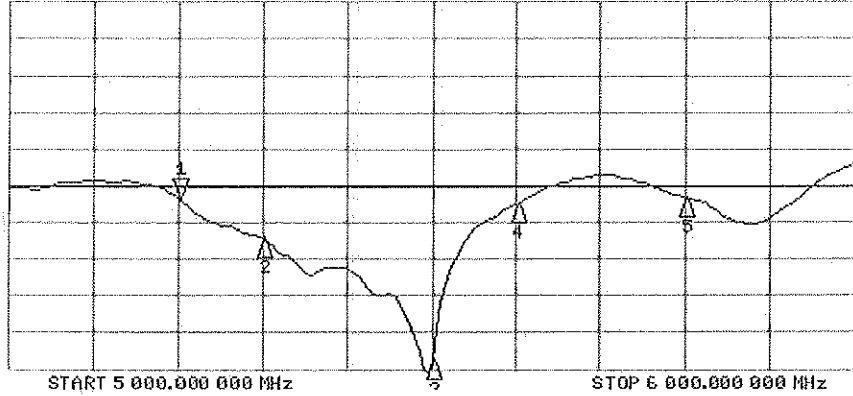

CH2 Markers

- 2: -27.251 dB
5.30000 GHz
- 3: -43.776 dB
5.50000 GHz
- 4: -22.442 dB
5.60000 GHz
- 5: -21.682 dB
5.80000 GHz

APPENDIX D: SAR TISSUE SPECIFICATIONS

Measurement Procedure for Tissue verification:



- 1) The network analyzer and probe system was configured and calibrated.
- 2) The probe was immersed in the tissue. The tissue was placed in a nonmetallic container. Trapped air bubbles beneath the flange were minimized by placing the probe at a slight angle.
- 3) The complex admittance with respect to the probe aperture was measured
- 4) The complex relative permittivity ϵ can be calculated from the below equation (Pournaropoulos and Misra):

$$Y = \frac{j2\omega\epsilon_r\epsilon_0}{[\ln(b/a)]^2} \int_a^b \int_a^b \int_0^\pi \cos\phi' \frac{\exp[-j\omega r(\mu_0\epsilon_r\epsilon_0)^{1/2}]}{r} d\phi' d\rho' d\rho$$

where Y is the admittance of the probe in contact with the sample, the primed and unprimed coordinates refer to source and observation points, respectively, $r^2 = \rho^2 + \rho'^2 - 2\rho\rho'\cos\phi'$, ω is the angular frequency, and $j = \sqrt{-1}$.

Table D-I
Composition of the Tissue Equivalent Matter

Frequency (MHz)	750	835	1750	1900	2450	5200-5800
Tissue	Body	Body	Body	Body	Body	Body
Ingredients (% by weight)						
Bactericide	See page 2	0.1				
DGBE			31	29.44	26.7	
HEC		1				
NaCl		0.94	0.2	0.39	0.1	
Sucrose		44.9				
Polysorbate (Tween) 80						20
Water		53.06	68.8	70.17	73.2	80

FCC ID: ZNFV495		SAR EVALUATION REPORT		Reviewed by: Quality Manager
Test Dates: 03/16/15 - 03/25/15	DUT Type: Portable Tablet			APPENDIX D: Page 1 of 2

2 Composition / Information on ingredients

The Item is composed of the following ingredients:

H ₂ O	Water, 35 – 58%
Sucrose	Sugar, white, refined, 40 – 60%
NaCl	Sodium Chloride, 0 – 6%
Hydroxyethyl-cellulose	Medium Viscosity (CAS# 9004-62-0), <0.3%
Preventol-D7	Preservative: aqueous preparation, (CAS# 55965-84-9), containing 5-chloro-2-methyl-3(2H)-isothiazolone and 2-methyl-3(2H)-isothiazolone, 0.1 – 0.7%

Relevant for safety; Refer to the respective Safety Data Sheet*.

**Figure D-1
Composition of 750 MHz Body Tissue Equivalent Matter**

Note: 750MHz liquid recipes are proprietary SPEAG. Since the composition is approximate to the actual liquids utilized, the manufacturer tissue-equivalent liquid data sheets are provided below.

Measurement Certificate / Material Test

Item Name	Body Tissue Simulating Liquid (MSL750V2)
Product No.	SL AAM 075 AA (Charge: 130828-1)
Manufacturer	SPEAG

Measurement Method

TSL dielectric parameters measured using calibrated OCP probe.

Setup Validation

Validation results were within $\pm 2.5\%$ towards the target values of Methanol.

Target Parameters

Target parameters as defined in the IEEE 1528 and IEC 62209 compliance standards.

Test Condition

Ambient	Environment temperatur (22 ± 3)°C and humidity < 70%.
TSL Temperature	22°C
Test Date	28-Aug-13
Operator	IEN



Additional Information

TSL Density	1.212 g/cm ³
TSL Heat-capacity	3.006 kJ/(kg*K)

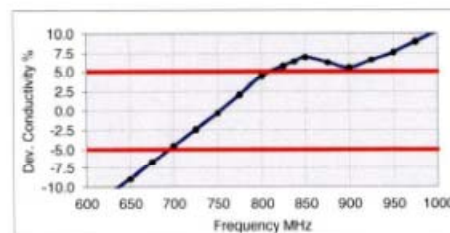
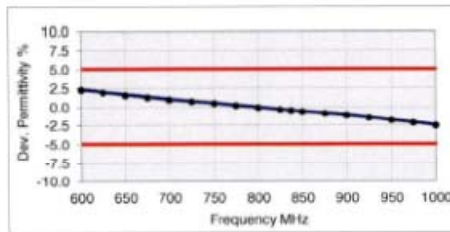
f [MHz]	Measured			Target		Diff. to Target [%]	
	HP-e'	HP-e''	sigma	eps	sigma	Δ-eps	Δ-sigma
600	57.4	24.76	0.83	56.1	0.95	2.3	-13.2
625	57.1	24.42	0.85	56.0	0.95	2.0	-11.0
650	56.8	24.09	0.87	55.9	0.96	1.6	-8.9
675	56.6	23.80	0.89	55.8	0.96	1.3	-6.7
700	56.3	23.52	0.92	55.7	0.96	1.0	-4.5
725	56.1	23.27	0.94	55.6	0.96	0.8	-2.4
750	55.8	23.03	0.96	55.5	0.96	0.5	-0.3
775	55.6	22.87	0.99	55.4	0.97	0.2	2.1
800	55.3	22.71	1.01	55.3	0.97	-0.1	4.5
825	55.1	22.54	1.03	55.2	0.98	-0.3	5.8
838	54.9	22.45	1.05	55.2	0.98	-0.5	6.4
850	54.8	22.37	1.06	55.2	0.99	-0.6	7.0
875	54.6	22.25	1.08	55.1	1.02	-0.9	6.2
900	54.4	22.13	1.11	55.0	1.06	-1.1	5.5
925	54.2	22.02	1.13	55.0	1.06	-1.5	6.6
950	53.9	21.91	1.16	54.9	1.08	-1.8	7.7
975	53.7	21.84	1.18	54.9	1.09	-2.2	9.0
1000	53.5	21.77	1.21	54.8	1.10	-2.5	10.3



**Figure D-2
750MHz Body Tissue Equivalent Matter**

FCC ID: ZNFV495		SAR EVALUATION REPORT		Reviewed by: Quality Manager
Test Dates: 03/16/15 - 03/25/15	DUT Type: Portable Tablet			APPENDIX D: Page 2 of 2

APPENDIX E: SAR SYSTEM VALIDATION



Per FCC KDB 865664 D02v01, SAR system validation status should be documented to confirm measurement accuracy. The SAR systems (including SAR probes, system components and software versions) used for this device were validated against its performance specifications prior to the SAR measurements. Reference dipoles were used with the required tissue- equivalent media for system validation, according to the procedures outlined in FCC KDB 865664 D01 v01 and IEEE 1528-2013. Since SAR probe calibrations are frequency dependent, each probe calibration point was validated at a frequency within the valid frequency range of the probe calibration point, using the system that normally operates with the probe for routine SAR measurements and according to the required tissue-equivalent media.

A tabulated summary of the system validation status including the validation date(s), measurement frequencies, SAR probes and tissue dielectric parameters has been included.

Table E-I
SAR System Validation Summary

SAR SYSTEM #	FREQ. [MHz]	DATE	PROBE SN	PROBE TYPE	PROBE CAL. POINT		COND.	PERM.	CW VALIDATION			MOD. VALIDATION		
							(σ)	(ϵ_r)	SENSI-TIVITY	PROBE LINEARITY	PROBE ISOTROPY	MOD. TYPE	DUTY FACTOR	PAR
D	750	10/20/2014	3263	ES3DV3	750	Body	0.971	55.55	PASS	PASS	PASS	N/A	N/A	N/A
K	835	10/13/2014	3288	ES3DV3	835	Body	0.998	52.95	PASS	PASS	PASS	GMSK	PASS	N/A
E	1750	11/4/2014	3332	ES3DV3	1750	Body	1.477	51.77	PASS	PASS	PASS	N/A	N/A	N/A
D	1900	10/9/2014	3263	ES3DV3	1900	Body	1.569	52.31	PASS	PASS	PASS	GMSK	PASS	N/A
G	2450	3/17/2015	3213	ES3DV3	2450	Body	2.028	50.80	PASS	PASS	PASS	OFDM/TDD	PASS	PASS
G	2600	3/17/2015	3213	ES3DV3	2600	Body	2.228	50.19	PASS	PASS	PASS	TDD	PASS	N/A
A	5200	2/19/2015	3914	EX3DV4	5200	Body	5.054	47.76	PASS	PASS	PASS	OFDM	N/A	PASS
A	5300	2/19/2015	3914	EX3DV4	5300	Body	5.181	47.44	PASS	PASS	PASS	OFDM	N/A	PASS
A	5500	2/19/2015	3914	EX3DV4	5500	Body	5.464	46.92	PASS	PASS	PASS	OFDM	N/A	PASS
A	5600	2/19/2015	3914	EX3DV4	5600	Body	5.607	46.70	PASS	PASS	PASS	OFDM	N/A	PASS
A	5800	2/19/2015	3914	EX3DV4	5800	Body	5.942	46.31	PASS	PASS	PASS	OFDM	N/A	PASS

NOTE: While the probes have been calibrated for both CW and modulated signals, all measurements were performed using communication systems calibrated for CW signals only. Modulations in the table above represent test configurations for which the measurement system has been validated per FCC KDB Publication 865664 D01v01 for scenarios when CW probe calibrations are used with other signal types. SAR systems were validated for modulated signals with a periodic duty cycle, such as GMSK, or with a high peak to average ratio (>5 dB), such as OFDM according to KDB 865664.

FCC ID: ZNFV495		SAR EVALUATION REPORT		Reviewed by: Quality Manager
Test Dates: 03/16/15 - 03/25/15	DUT Type: Portable Tablet			APPENDIX E: Page 1 of 1