



FCC RF Test Report

APPLICANT : LG Electronics Inc.
EQUIPMENT : Tablet
BRAND NAME : LG Electronics Inc
MODEL NAME : LG-V490
FCC ID : ZNFV490
STANDARD : 47 CFR Part 2, 27
CLASSIFICATION : PCS Licensed Transmitter (PCB)

The product was received on May 17, 2014 and testing was completed on Jun. 25, 2014. We, SPORTON INTERNATIONAL INC., would like to declare that the tested sample has been evaluated in accordance with the test procedures given in ANSI / TIA / EIA-603-C-2004 and the testing has shown the tested sample to be in compliance with the applicable technical standards.

The test results in this report apply exclusively to the tested model / sample. Without written approval of SPORTON INTERNATIONAL INC., the test report shall not be reproduced except in full.

Reviewed by: Joseph Lin / Supervisor

Approved by: Jones Tsai / Manager



Testing Laboratory
1190

SPORTON INTERNATIONAL INC.

No. 52, Hwa Ya 1st Rd., Hwa Ya Technology Park, Kwei-Shan Hsiang, Tao Yuan Hsien, Taiwan, R.O.C.

SPORTON INTERNATIONAL INC.

TEL : 886-3-327-3456

FAX : 886-3-328-4978

FCC ID : ZNFV490

Page Number : 1 of 168

Report Issued Date : Jul. 18, 2014

Report Version : Rev. 02

Report Template No.: BU5-FGLTE Version 1.1



TABLE OF CONTENTS

REVISION HISTORY..... 3

SUMMARY OF TEST RESULT 4

1 GENERAL DESCRIPTION 6

1.1 Applicant 6

1.2 Manufacturer 6

1.3 Product Feature of Equipment Under Test..... 6

1.4 Product Specification subjective to this standard 6

1.5 Modification of EUT 7

1.6 Maximum EIRP Power, Frequency Tolerance, and Emission Designator 7

1.7 Testing Location 8

1.8 Applicable Standards..... 8

2 TEST CONFIGURATION OF EQUIPMENT UNDER TEST 9

2.1 Test Mode 9

2.2 Connection Diagram of Test System 10

2.3 Support Unit used in test configuration and system 10

2.4 Measurement Results Explanation Example..... 10

3 TEST RESULT 11

3.1 Conducted Output Power Measurement 11

3.2 Peak-to-Average Ratio 17

3.3 Equivalent Isotropic Radiated Power Measurement 25

3.4 Occupied Bandwidth 37

3.5 Conducted Band Edge Measurement 98

3.6 Conducted Spurious Emission Measurement 140

3.7 Radiated Spurious Emission Measurement 152

3.8 Frequency Stability Measurement 164

4 LIST OF MEASURING EQUIPMENT 167

5 UNCERTAINTY OF EVALUATION 168

APPENDIX A. SETUP PHOTOGRAPHS



REVISION HISTORY

REPORT NO.	VERSION	DESCRIPTION	ISSUED DATE
FG451713B	Rev. 01	Initial issue of report	Jul. 11, 2014
FG451713B	Rev. 02	Revising FCC rule in summary of test result.	Jul. 18, 2014



SUMMARY OF TEST RESULT

Report Section	FCC Rule	IC Rule	Description	Limit	Result	Remark
3.1	§2.1046	RSS-Gen(4.8) RSS-139 (6.4) RSS-199 (4.4)	Conducted Output Power	Reporting Only	PASS	-
3.2	§24.232(d) §27.50(d)(5)	RSS-139 (6.4)	Peak-to-Average Ratio	<13 dB	PASS	-
3.3	§27.50(h)(2)	SRSP-510(5.1.2) RSS-199 (4.4)	Equivalent Isotropic Radiated Power (Band 7)	EIRP < 2Watt	PASS	-
	§27.50(d)(4)	RSS-139 (6.4) SRSP-513(5.1.2)	Equivalent Isotropic Radiated Power (Band 4)	EIRP < 1Watt		
3.4	§2.1049 §27.53(g)(3) §27.53(m)(6)	RSS-GEN(4.6.1) RSS-139 (3.1) RSS-199 (4.2)	Occupied Bandwidth	Reporting Only	PASS	-
3.5	§2.1051 §27.53(h) §27.53(m)(4)	RSS-GEN(4.9) RSS-139 (6.5) RSS-199 (4.5)	Conducted Band Edge Measurement (Band 4) (Band 7)	< 43+10log ₁₀ (P[Watt])	PASS	-
3.6	§2.1051 §27.53(h)	RSS-GEN(4.9) RSS-139 (6.5)	Conducted Spurious Emission (Band 4)	< 43+10log ₁₀ (P[Watts])	PASS	-
	§2.1051 §27.53(m)(4)	RSS-GEN(4.9) RSS-199 (4.5)	Conducted Spurious Emission (Band 7)	< 55+10log ₁₀ (P[Watts])	PASS	-



Report Section	FCC Rule	IC Rule	Description	Limit	Result	Remark
3.7	§2.1053 §27.53(h)	RSS-GEN(4.9) RSS-139 (6.5)	Radiated Spurious Emission (Band 4)	$< 43+10\log_{10}(P[\text{Watts}])$	PASS	Under limit 6.60 dB at 10110 MHz
	§2.1053 §27.53(m)(4)	RSS-GEN(4.9) RSS-199 (4.5)	Radiated Spurious Emission (Band 7)	$< 55+10\log_{10}(P[\text{Watts}])$	PASS	
3.8	§2.1055 §27.54	RSS-GEN(4.7) RSS-139 (6.3) RSS-199 (4.3)	Frequency Stability Temperature & Voltage	$< 2.5 \text{ ppm}$	PASS	



1 General Description

1.1 Applicant

LG Electronics Inc.

60-39, Kasan-dong, Keumchun-ku, Seoul Korea Zip code: 153-023

1.2 Manufacturer

LG ELECTRONICS MOBILECOMM U.S.A., INC.

100 SYLVAN AVENUE ENGEWOOD CLIFFS, NEW JERSEY, 07632, U.S.A.

1.3 Product Feature of Equipment Under Test

Product Feature	
Equipment	Tablet
Brand Name	LG Electronics Inc
Model Name	LG-V490
FCC ID	ZNFV490
EUT supports Radios application	GSM/EGPRS/WCDMA/HSPA/LTE WLAN 11b/g/n HT20 WLAN 11a/n HT20/HT40 Bluetooth v4.0 EDR/LE
HW Version	Rev.A
SW Version	V107a-Op1-HQ
EUT Stage	Identical Prototype

Remark: The above EUT's information was declared by manufacturer. Please refer to the specifications or user's manual for more detailed description.

1.4 Product Specification subjective to this standard

Product Specification subjective to this standard	
Tx Frequency	LTE Band 4 : 1710.7 MHz ~ 1754.3 MHz LTE Band 7 : 2502.5 MHz ~ 2567.5 MHz
Rx Frequency	LTE Band 4 : 2110.7 MHz ~ 2154.3 MHz LTE Band 7 : 2622.5MHz ~ 2687.5 MHz
Bandwidth	LTE Band 4 : 1.4MHz / 3MHz / 5MHz / 10MHz / 15MHz / 20MHz LTE Band 7 : 5MHz/ 10MHz / 15MHz / 20MHz
Maximum Output Power to Antenna	LTE Band 4 : 23.69 dBm LTE Band 7 : 23.63 dBm
Antenna Type	PIFA Antenna
Type of Modulation	QPSK / 16QAM



1.5 Modification of EUT

No modifications are made to the EUT during all test items.

1.6 Maximum EIRP Power, Frequency Tolerance, and Emission Designator

FCC Rule	System	Type of Modulation	BW	Emission Designator	Frequency Tolerance (ppm)	Maximum EIRP
Part 27	LTE Band 4	QPSK	1.4 MHz	1M11G7D	-	0.32 W
Part 27	LTE Band 4	16QAM	1.4 MHz	1M11D7W	-	0.24 W
Part 27	LTE Band 4	QPSK	3 MHz	2M74G7D	-	0.31 W
Part 27	LTE Band 4	16QAM	3 MHz	2M74D7W	-	0.23 W
Part 27	LTE Band 4	QPSK	5MHz	4M50G7D	-	0.32 W
Part 27	LTE Band 4	16QAM	5MHz	4M50D7W	-	0.24 W
Part 27	LTE Band 4	QPSK	10MHz	9M08G7D	0.01 ppm	0.29 W
Part 27	LTE Band 4	16QAM	10MHz	9M04D7W	-	0.24 W
Part 27	LTE Band 4	QPSK	15MHz	13M5G7D	-	0.31 W
Part 27	LTE Band 4	16QAM	15MHz	13M5D7W	-	0.23 W
Part 27	LTE Band 4	QPSK	20MHz	18M5G7D	-	0.30 W
Part 27	LTE Band 4	16QAM	20MHz	18M5D7W	-	0.23 W
Part 27	LTE Band 7	QPSK	5MHz	4M50G7D	-	0.37 W
Part 27	LTE Band 7	16QAM	5MHz	4M50D7W	-	0.28 W
Part 27	LTE Band 7	QPSK	10MHz	9M06G7D	0.01 ppm	0.37 W
Part 27	LTE Band 7	16QAM	10MHz	9M04D7W	-	0.29 W
Part 27	LTE Band 7	QPSK	15MHz	13M4G7D	-	0.37 W
Part 27	LTE Band 7	16QAM	15MHz	13M5D7W	-	0.28 W
Part 27	LTE Band 7	QPSK	20MHz	18M4G7D	-	0.38 W
Part 27	LTE Band 7	16QAM	20MHz	18M4D7W	-	0.28 W



1.7 Testing Location

Sporton Lab is accredited to ISO 17025 by Taiwan Accreditation Foundation (TAF code : 1190) and the FCC designation No. TW1022 under the FCC 2.948(e) by Mutual Recognition Agreement (MRA) in FCC Test.

Test Site	SPORTON INTERNATIONAL INC.		
Test Site Location	No. 52, Hwa Ya 1 st Rd., Hwa Ya Technology Park, Kwei-Shan Hsiang, Tao Yuan Hsien, Taiwan, R.O.C. TEL: +886-3-327-3456 FAX: +886-3-328-4978		
Test Site No.	Sporton Site No.		IC Registration No.
	TH02-HY	03CH07-HY	4086B-1

1.8 Applicable Standards

According to the specifications of the manufacturer, the EUT must comply with the requirements of the following standards:

- ♦ 47 CFR Part 2, 27
- ♦ ANSI / TIA / EIA-603-C-2004
- ♦ FCC KDB 971168 D01 Power Meas. License Digital Systems v02r01

Remark: All test items were verified and recorded according to the standards and without any deviation during the test.



2 Test Configuration of Equipment Under Test

2.1 Test Mode

Antenna port conducted and radiated test items listed below are performed according to KDB 971168 D01 Power Meas. License Digital Systems v02r01 with maximum output power.

Radiated measurements are performed by rotating the EUT in three different orthogonal test planes to find the maximum emission.

Test Items	Band	Bandwidth (MHz)						Modulation		RB #			Test Channel		
		1.4	3	5	10	15	20	QPSK	16QAM	1	Half	Full	L	M	H
Max. Output Power	4	v	v	v	v	v	v	v	v	v	v	v	v	v	v
	7	-	-	v	v	v	v	v	v	v	v	v	v	v	v
Peak-to-Average Ratio	4						v		v	v		v	v	v	v
	7	-	-				v		v	v		v	v	v	v
26dB and 99% Bandwidth	4	v	v	v	v	v	v	v	v			v	v	v	v
	7	-	-	v	v	v	v	v	v			v	v	v	v
Conducted Band Edge	4	v	v	v	v	v	v	v	v	v		v	v		v
	7	-	-	v	v	v	v	v	v	v		v	v		v
Conducted Spurious Emission	4	v	v	v	v	v	v	v	v	v				v	
	7	-	-	v	v	v	v	v	v	v				v	
Frequency Stability	4				v			v				v		v	
	7	-	-		v			v				v		v	
E.I.R.P.	4	v	v	v	v	v	v	v	v	v			v	v	v
	7	-	-	v	v	v	v	v	v	v			v	v	v
Radiated Spurious Emission	4	v	v	v	v	v	v	v		v				v	
	7	-	-	v	v	v	v	v		v				v	
Note	<ol style="list-style-type: none"> The mark "v" means that this configuration is chosen for testing The mark "-" means that this bandwidth is not supported. The device is investigated from 30MHz to 10 times of fundamental signal for radiated spurious emission test under different RB size/offset and modulations in exploratory test. Subsequently, only the worst case emissions are reported. 														

2.2 Connection Diagram of Test System

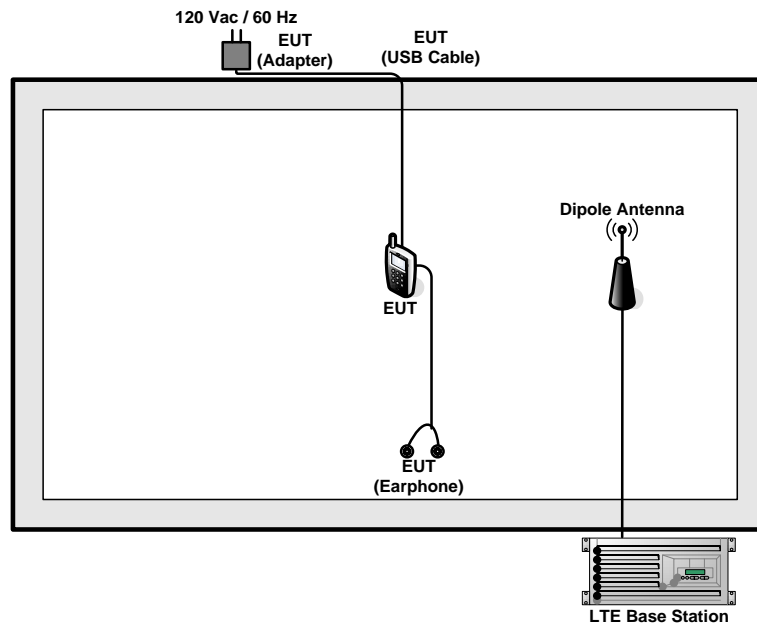

2.3 Support Unit used in test configuration and system

Item	Equipment	Trade Name	Model No.	FCC ID	Data Cable	Power Cord
1.	LTE Base Station	Anritsu	MT8820C	N/A	N/A	Unshielded, 1.8 m

2.4 Measurement Results Explanation Example

For all conducted test items:

The offset level is set in the spectrum analyzer to compensate the RF cable loss and attenuator factor between EUT conducted output port and spectrum analyzer. With the offset compensation, the spectrum analyzer reading level is exactly the EUT RF output level.

The spectrum analyzer offset is derived from RF cable loss and attenuator factor.

Offset = RF cable loss + attenuator factor.

Following shows an offset computation example with cable loss 4.2 dB and 10dB attenuator.

Example :

Offset(dB) = RF cable loss(dB) + attenuator factor(dB).

$$= 4.2 + 10 = 14.2 \text{ (dB)}$$

3 Test Result

3.1 Conducted Output Power Measurement

3.1.1 Description of the Conducted Output Power Measurement

A system simulator was used to establish communication with the EUT. Its parameters were set to force the EUT transmitting at maximum output power. The measured power in the radio frequency on the transmitter output terminals shall be reported.

3.1.2 Measuring Instruments

The measuring equipment is listed in the section 4 of this test report.

3.1.3 Test Procedures

1. The transmitter output port was connected to the system simulator.
2. Set EUT at maximum power through the system simulator.
3. Select lowest, middle, and highest channels for each band and different modulation.
4. Measure and record the power level from the system simulator.

3.1.4 Test Setup

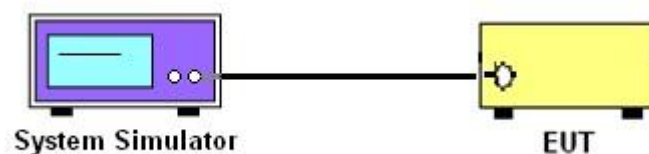



3.1.5 Test Result of Conducted Output Power

<LTE Band 4 Conducted Power>

BW [MHz]	Modulation	RB Size	RB Offset	Power (dBm) Low Ch. / Freq.	Power (dBm) Middle Ch. / Freq.	Power (dBm) High Ch. / Freq.
Channel				20050	20175	20300
Frequency (MHz)				1720	1732.5	1745
20	QPSK	1	0	23.27	23.69	23.59
20	QPSK	1	49	23.32	23.68	23.60
20	QPSK	1	99	23.26	23.67	23.54
20	QPSK	50	0	22.25	22.63	22.66
20	QPSK	50	24	22.23	22.59	22.57
20	QPSK	50	49	22.23	22.50	22.59
20	QPSK	100	0	22.37	22.66	22.38
20	16QAM	1	0	22.21	22.34	22.20
20	16QAM	1	49	22.34	22.47	22.47
20	16QAM	1	99	22.27	22.52	22.40
20	16QAM	50	0	21.32	21.68	21.45
20	16QAM	50	24	21.25	21.47	21.46
20	16QAM	50	49	21.20	21.31	21.24
20	16QAM	100	0	21.29	21.48	21.21
Channel				20025	20175	20325
Frequency (MHz)				1717.5	1732.5	1747.5
15	QPSK	1	0	23.46	23.50	23.52
15	QPSK	1	37	23.43	23.48	23.43
15	QPSK	1	74	23.41	23.46	23.48
15	QPSK	36	0	22.31	22.48	22.55
15	QPSK	36	18	22.32	22.62	22.47
15	QPSK	36	37	22.23	22.44	22.39
15	QPSK	75	0	22.44	22.66	22.29
15	16QAM	1	0	22.37	22.27	22.28
15	16QAM	1	37	22.31	22.32	22.47
15	16QAM	1	74	22.28	22.39	22.30
15	16QAM	36	0	21.39	21.58	21.25
15	16QAM	36	18	21.23	21.29	21.33
15	16QAM	36	37	21.21	21.23	21.26
15	16QAM	75	0	21.28	21.35	21.21



BW [MHz]	Modulation	RB Size	RB Offset	Power (dBm) Low Ch. / Freq.	Power (dBm) Middle Ch. / Freq.	Power (dBm) High Ch. / Freq.
Channel				20000	20175	20350
Frequency (MHz)				1715	1732.5	1750
10	QPSK	1	0	23.34	23.42	23.59
10	QPSK	1	24	23.36	23.50	23.49
10	QPSK	1	49	23.32	23.56	23.37
10	QPSK	25	0	22.43	22.60	22.63
10	QPSK	25	12	22.22	22.52	22.53
10	QPSK	25	24	22.28	22.47	22.59
10	QPSK	50	0	22.29	22.60	22.25
10	16QAM	1	0	22.21	22.25	22.20
10	16QAM	1	24	22.31	22.30	22.46
10	16QAM	1	49	22.24	22.39	22.29
10	16QAM	25	0	21.32	21.57	21.37
10	16QAM	25	12	21.20	21.31	21.36
10	16QAM	25	24	21.23	21.29	21.24
10	16QAM	50	0	21.26	21.36	21.22
Channel				19975	20175	20375
Frequency (MHz)				1712.5	1732.5	1752.5
5	QPSK	1	0	23.28	23.53	23.50
5	QPSK	1	12	23.34	23.47	23.46
5	QPSK	1	24	23.26	23.47	23.34
5	QPSK	12	0	22.23	22.52	22.46
5	QPSK	12	6	22.24	22.56	22.42
5	QPSK	12	11	22.26	22.45	22.54
5	QPSK	25	0	22.28	22.69	22.36
5	16QAM	1	0	22.32	22.23	22.20
5	16QAM	1	12	22.24	22.27	22.42
5	16QAM	1	24	22.21	22.38	22.44
5	16QAM	12	0	21.54	21.65	21.58
5	16QAM	12	6	21.34	21.35	21.53
5	16QAM	12	11	21.24	21.21	21.31
5	16QAM	25	0	21.22	21.28	21.22



BW [MHz]	Modulation	RB Size	RB Offset	Power (dBm) Low Ch. / Freq.	Power (dBm) Middle Ch. / Freq.	Power (dBm) High Ch. / Freq.
Channel				19965	20175	20385
Frequency (MHz)				1711.5	1732.5	1753.5
3	QPSK	1	0	23.25	23.46	23.59
3	QPSK	1	7	23.34	23.50	23.40
3	QPSK	1	14	23.28	23.52	23.44
3	QPSK	8	0	22.26	22.43	22.50
3	QPSK	8	4	22.25	22.52	22.57
3	QPSK	8	7	22.24	22.39	22.55
3	QPSK	15	0	22.23	22.56	22.21
3	16QAM	1	0	22.38	22.34	22.23
3	16QAM	1	7	22.26	22.28	22.44
3	16QAM	1	14	22.37	22.37	22.39
3	16QAM	8	0	21.29	21.48	21.46
3	16QAM	8	4	21.38	21.47	21.42
3	16QAM	8	7	21.25	21.22	21.25
3	16QAM	15	0	21.33	21.36	21.21
Channel				19957	20175	20393
Frequency (MHz)				1710.7	1732.5	1754.3
1.4	QPSK	1	0	23.22	23.50	23.59
1.4	QPSK	1	2	23.21	23.42	23.41
1.4	QPSK	1	5	23.25	23.46	23.47
1.4	QPSK	3	0	22.56	22.92	22.95
1.4	QPSK	3	1	22.62	22.96	22.97
1.4	QPSK	3	2	22.58	22.95	22.90
1.4	QPSK	6	0	22.28	22.68	22.33
1.4	16QAM	1	0	22.32	22.20	22.23
1.4	16QAM	1	2	22.31	22.45	22.27
1.4	16QAM	1	5	22.25	22.52	22.21
1.4	16QAM	3	0	21.82	22.06	21.97
1.4	16QAM	3	1	21.80	21.92	21.97
1.4	16QAM	3	2	21.77	21.91	21.92
1.4	16QAM	6	0	21.26	21.34	21.21



<LTE Band 7 Conducted Power>

BW [MHz]	Modulation	RB Size	RB Offset	Power (dBm) Low Ch. / Freq.	Power (dBm) Middle Ch. / Freq.	Power (dBm) High Ch. / Freq.
Channel				20850	21100	21350
Frequency (MHz)				2510	2535	2560
20	QPSK	1	0	23.41	23.63	23.37
20	QPSK	1	49	23.40	23.55	23.39
20	QPSK	1	99	23.43	23.58	23.36
20	QPSK	50	0	22.33	22.45	22.35
20	QPSK	50	24	22.36	22.66	22.45
20	QPSK	50	49	22.45	22.70	22.54
20	QPSK	100	0	22.45	22.52	22.51
20	16QAM	1	0	22.28	22.32	22.20
20	16QAM	1	49	22.22	22.24	22.08
20	16QAM	1	99	22.30	22.46	22.24
20	16QAM	50	0	21.21	21.58	21.27
20	16QAM	50	24	21.25	21.53	21.20
20	16QAM	50	49	21.30	21.33	21.05
20	16QAM	100	0	21.26	21.57	21.23
Channel				20825	21100	21375
Frequency (MHz)				2507.5	2535	2562.5
15	QPSK	1	0	23.40	23.46	23.42
15	QPSK	1	37	23.20	23.41	23.34
15	QPSK	1	74	23.41	23.43	23.36
15	QPSK	36	0	22.30	22.27	22.01
15	QPSK	36	18	22.34	22.65	22.26
15	QPSK	36	37	22.40	22.69	22.48
15	QPSK	75	0	22.35	22.36	22.40
15	16QAM	1	0	22.34	22.31	21.88
15	16QAM	1	37	22.24	22.20	21.76
15	16QAM	1	74	22.27	22.38	21.98
15	16QAM	36	0	21.20	21.38	21.11
15	16QAM	36	18	21.21	21.39	21.03
15	16QAM	36	37	21.38	21.20	20.89
15	16QAM	75	0	21.25	21.34	20.90



BW [MHz]	Modulation	RB Size	RB Offset	Power (dBm) Low Ch. / Freq.	Power (dBm) Middle Ch. / Freq.	Power (dBm) High Ch. / Freq.
Channel				20800	21100	21400
Frequency (MHz)				2505	2535	2565
10	QPSK	1	0	23.37	23.56	23.34
10	QPSK	1	24	23.40	23.48	23.28
10	QPSK	1	49	23.38	23.43	23.24
10	QPSK	25	0	22.24	22.30	21.91
10	QPSK	25	12	22.25	22.55	22.23
10	QPSK	25	24	22.35	22.69	22.38
10	QPSK	50	0	22.27	22.39	22.30
10	16QAM	1	0	22.25	22.30	21.88
10	16QAM	1	24	22.21	22.23	21.76
10	16QAM	1	49	22.36	22.38	21.96
10	16QAM	25	0	21.25	21.36	21.20
10	16QAM	25	12	21.21	21.31	20.82
10	16QAM	25	24	21.23	21.26	20.79
10	16QAM	50	0	21.20	21.33	20.90
Channel				20775	21100	21425
Frequency (MHz)				2502.5	2535	2567.5
5	QPSK	1	0	23.21	23.57	23.32
5	QPSK	1	12	23.26	23.44	23.22
5	QPSK	1	24	23.41	23.56	23.27
5	QPSK	12	0	22.21	22.31	21.91
5	QPSK	12	6	22.22	22.46	22.21
5	QPSK	12	11	22.42	22.67	22.36
5	QPSK	25	0	22.34	22.51	22.27
5	16QAM	1	0	22.27	22.32	21.85
5	16QAM	1	12	22.20	22.20	21.74
5	16QAM	1	24	22.24	22.34	21.97
5	16QAM	12	0	21.22	21.39	20.89
5	16QAM	12	6	21.25	21.37	20.97
5	16QAM	12	11	21.30	21.31	20.94
5	16QAM	25	0	21.26	21.40	21.07

Note: maximum average power for LTE.

3.2 Peak-to-Average Ratio

3.2.1 Description of the PAR Measurement

Power Complementary Cumulative Distribution Function (CCDF) curves provide a means for characterizing the power peaks of a digitally modulated signal on a statistical basis. A CCDF curve depicts the probability of the peak signal amplitude exceeding the average power level. Most contemporary measurement instrumentation include the capability to produce CCDF curves for an input signal provided that the instrument's resolution bandwidth can be set wide enough to accommodate the entire input signal bandwidth. In measuring transmissions in this band using an average power technique, the peak-to-average ratio (PAR) of the transmission may not exceed 13 dB.

3.2.2 Measuring Instruments

The measuring equipment is listed in the section 4 of this test report.

3.2.3 Test Procedures

1. The EUT was connected to spectrum and system simulator via a power divider.
2. Set the CCDF (Complementary Cumulative Distribution Function) option in spectrum analyzer.
3. The highest RF powers were measured and recorded the maximum PAPR level associated with a probability of 0.1 %.
4. Record the deviation as Peak to Average Ratio.

3.2.4 Test Setup

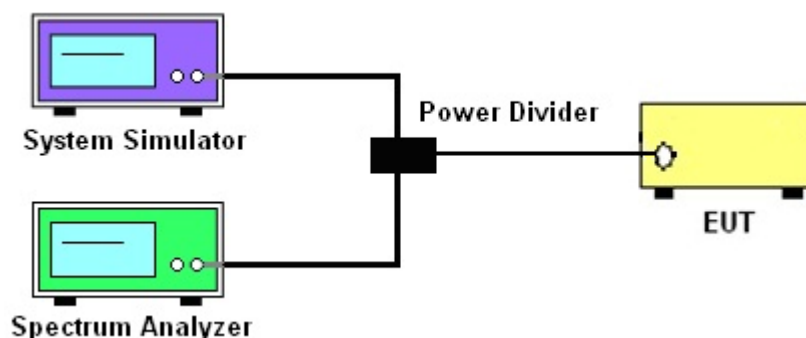



3.2.5 Test Result of Peak-to-Average Ratio

LTE Band 4						
BW [MHz]	Modulation	RB Size	RB Offset	Power (dBm) Low Ch. / Freq.	Power (dBm) Middle Ch. / Freq.	Power (dBm) High Ch. / Freq.
Channel				20050	20175	20300
Frequency (MHz)				1720	1732.5	1745
20	16QAM	1	0	5.96	4.23	4.49
20	16QAM	100	0	5.61	5.61	6.22

LTE Band 4						
BW [MHz]	Modulation	RB Size	RB Offset	Power (dBm) Low Ch. / Freq.	Power (dBm) Middle Ch. / Freq.	Power (dBm) High Ch. / Freq.
Channel				20850	21100	21350
Frequency (MHz)				2510.0	2535.0	2560.0
20	16QAM	1	0	5.00	5.64	5.96
20	16QAM	100	0	5.83	5.93	5.80



3.2.6 Peak to Average Power Ratio

Peak-to-Average Ratio on LTE Band 4 20MHz / 16QAM in Ch. 20050 (1RB Size)

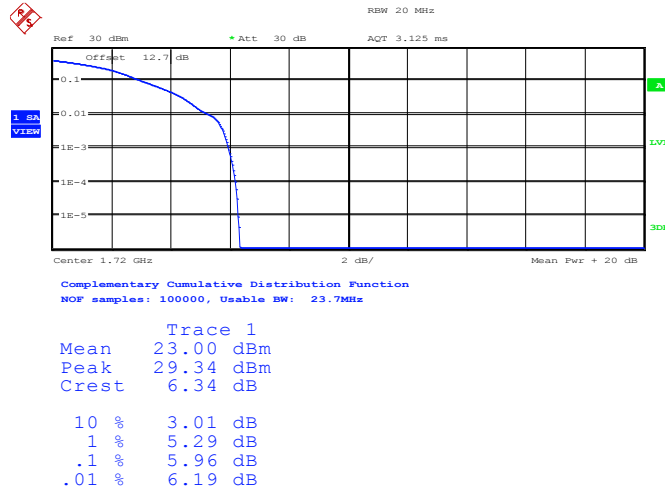

Date: 3.JUN.2014 23:41:31

Peak-to-Average Ratio on LTE Band 4 20MHz / 16QAM in Ch. 20175 (1RB Size)

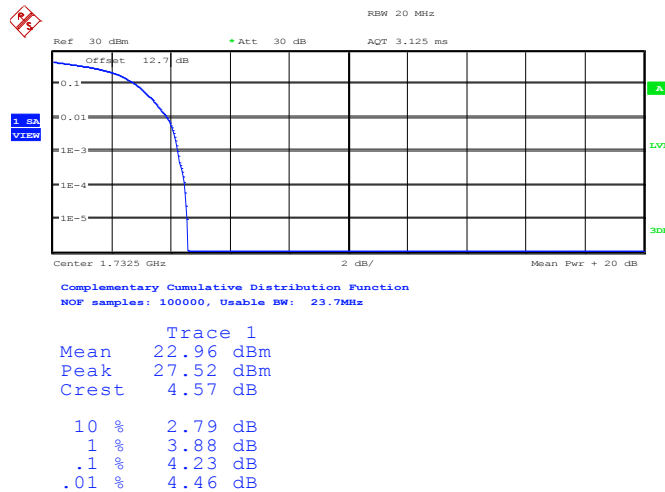

Date: 3.JUN.2014 23:42:13



Peak-to-Average Ratio on LTE Band 4
20MHz / 16QAM in Ch. 20300 (1RB Size)

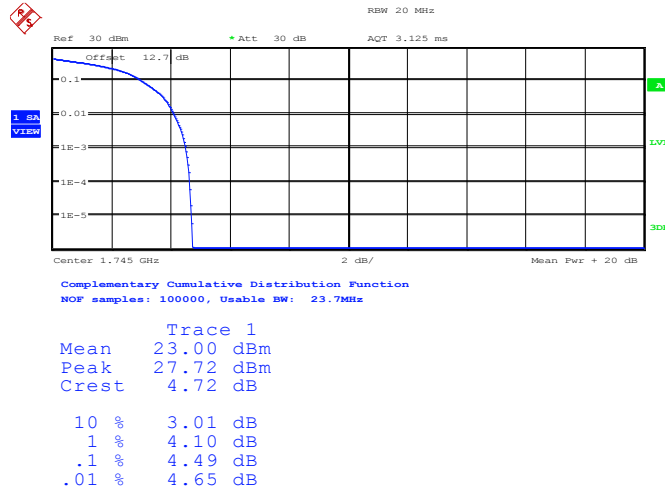

Date: 3.JUN.2014 23:42:58

Peak-to-Average Ratio on LTE Band 4
20MHz / 16QAM in Ch. 20050 (100RB Size)

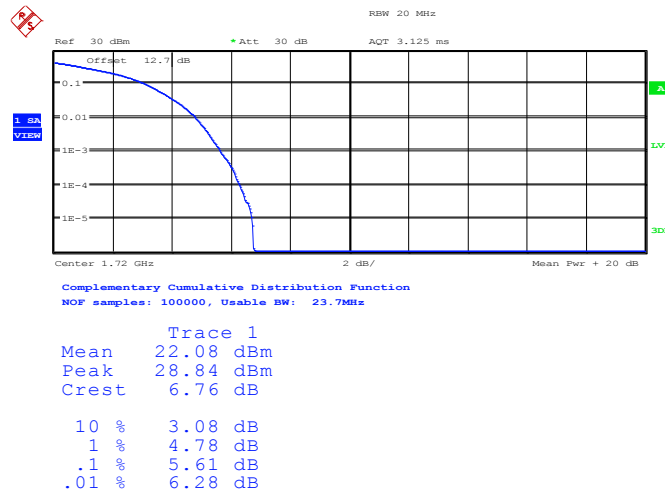

Date: 3.JUN.2014 23:41:50



Peak-to-Average Ratio on LTE Band 4
20MHz / 16QAM in Ch. 20175 (100RB Size)

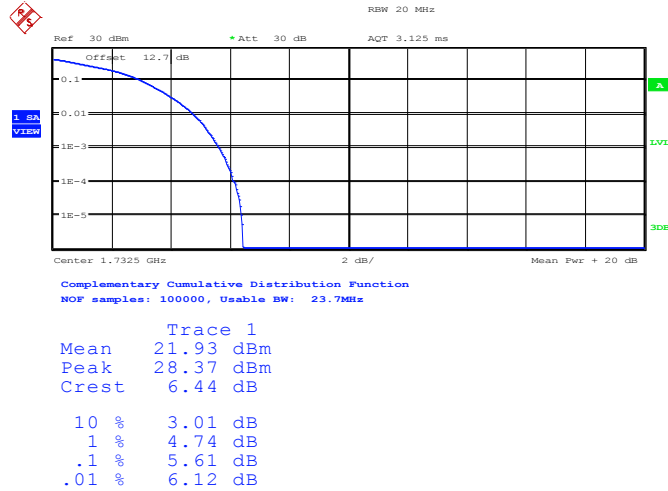

Date: 3.JUN.2014 23:42:33

Peak-to-Average Ratio on LTE Band 4
20MHz / 16QAM in Ch. 20300 (100RB Size)

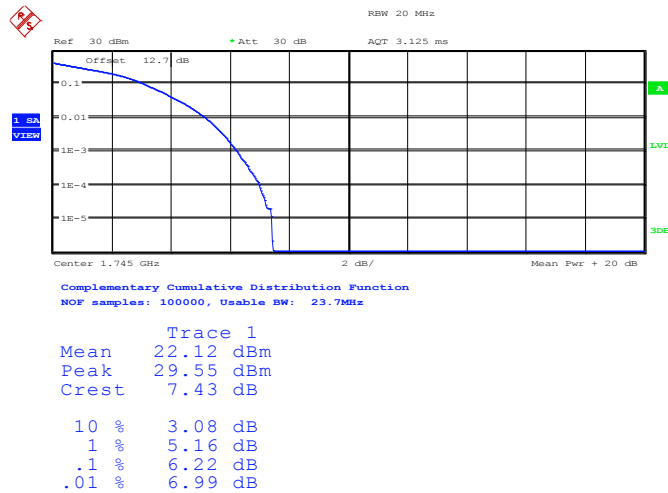

Date: 3.JUN.2014 23:43:16



Peak-to-Average Ratio on LTE Band 7
20MHz / 16QAM in Ch. 20850 (1RB Size)

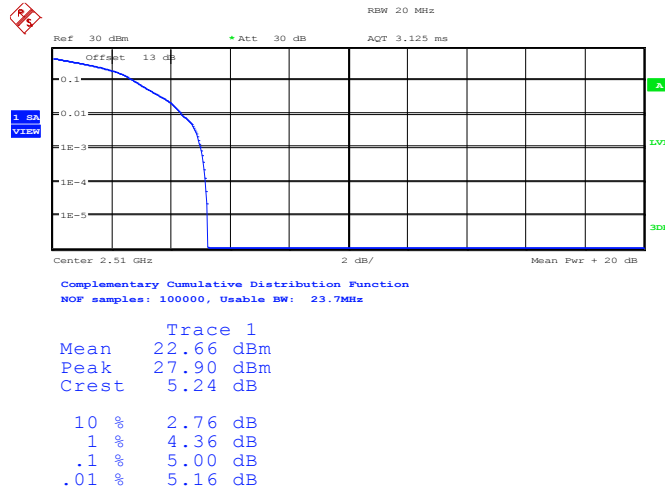

Date: 4.JUN.2014 01:20:14

Peak-to-Average Ratio on LTE Band 7
20MHz / 16QAM in Ch. 21100 (1RB Size)

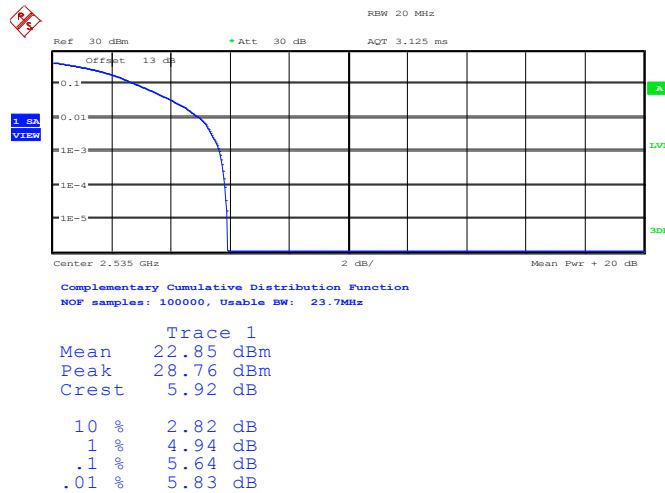

Date: 4.JUN.2014 01:20:45



Peak-to-Average Ratio on LTE Band 7
20MHz / 16QAM in Ch. 21350 (1RB Size)

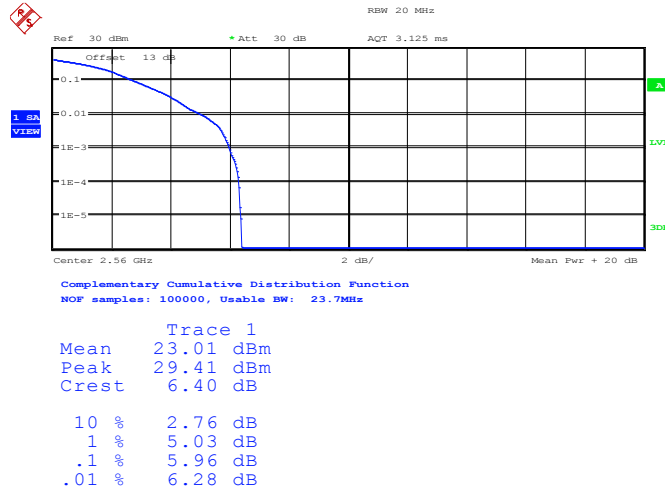

Date: 4.JUN.2014 01:21:21

Peak-to-Average Ratio on LTE Band 7
20MHz / 16QAM in Ch. 20850 (100RB Size)

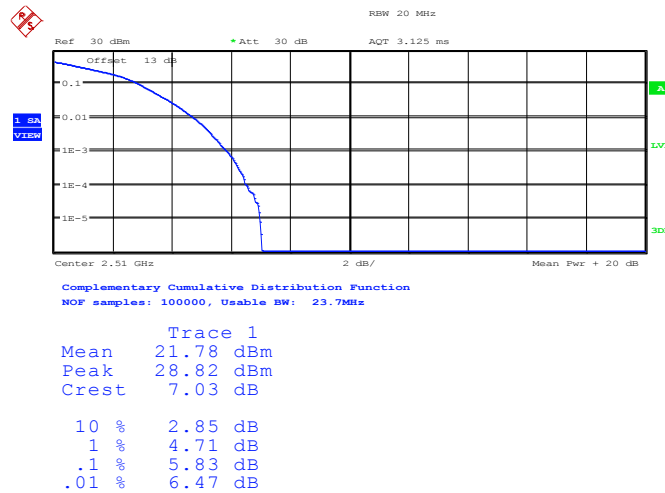

Date: 4.JUN.2014 01:20:30



Peak-to-Average Ratio on LTE Band 7
20MHz / 16QAM in Ch. 21100 (100RB Size)

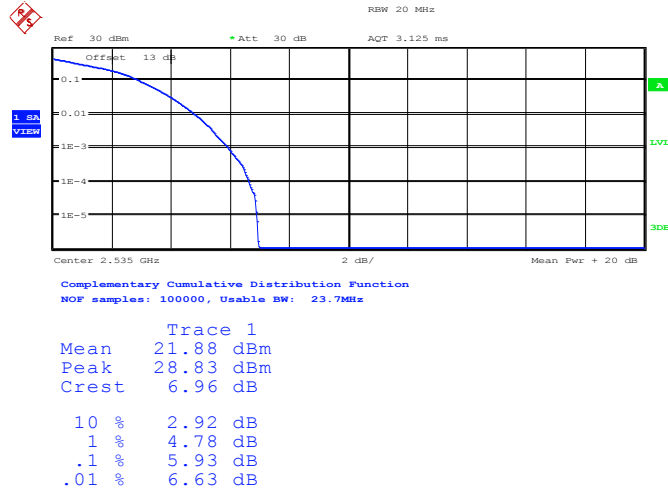

Date: 4.JUN.2014 01:21:04

Peak-to-Average Ratio on LTE Band 7
20MHz / 16QAM in Ch. 21350 (100RB Size)

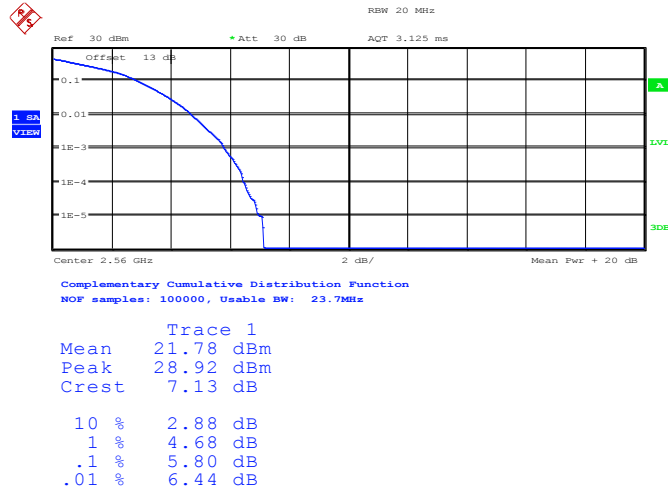

Date: 4.JUN.2014 01:21:36



3.3 Equivalent Isotropic Radiated Power Measurement

3.3.1 Description of the EIRP Measurement

Equivalent isotropic radiated power output measurements by substitution method according to ANSI / TIA / EIA-603-C-2004, and the spectrum analyzer configuration follows KDB 971168 D01 Power Meas. License Digital Systems v02r01. Mobile and portable (hand-held) stations operating are limited to average EIRP of 2 watts with LTE band 7 and 1 watt with LTE band 4.

3.3.2 Measuring Instruments

The measuring equipment is listed in the section 4 of this test report.

3.3.3 Test Procedures

1. The EUT was placed on a non-conductive rotating platform 0.8 meters high in a semi-anechoic chamber. The radiated emission at the fundamental frequency was measured at 3 m with a test antenna and a spectrum analyzer with RMS detector per section 5. of KDB 971168 D01.
2. During the measurement, the system simulator parameters were set to force the EUT transmitting at maximum output power. The maximum emission was recorded from analyzer power level (LVL) from the 360 degrees rotation of the turntable and the test antenna raised and lowered over a range from 1 to 4 meters in both horizontally and vertically polarized orientations.
3. Effective Isotropic Radiated Power (EIRP) was measured by substitution method according to TIA/EIA-603-C. The EUT was replaced by dipole antenna (substitution antenna) at same location, and then a known power from S.G. was applied into the dipole antenna through a Tx cable, and then recorded the maximum Analyzer reading through raised and lowered the test antenna. The correction factor (in dB) = S.G. - Tx Cable loss + Substitution antenna gain - Analyzer reading. Then the EUT's EIRP was calculated with the correction factor, $EIRP = LVL + \text{Correction factor}$ and $ERP = EIRP - 2.15$.

3.3.4 Test Setup

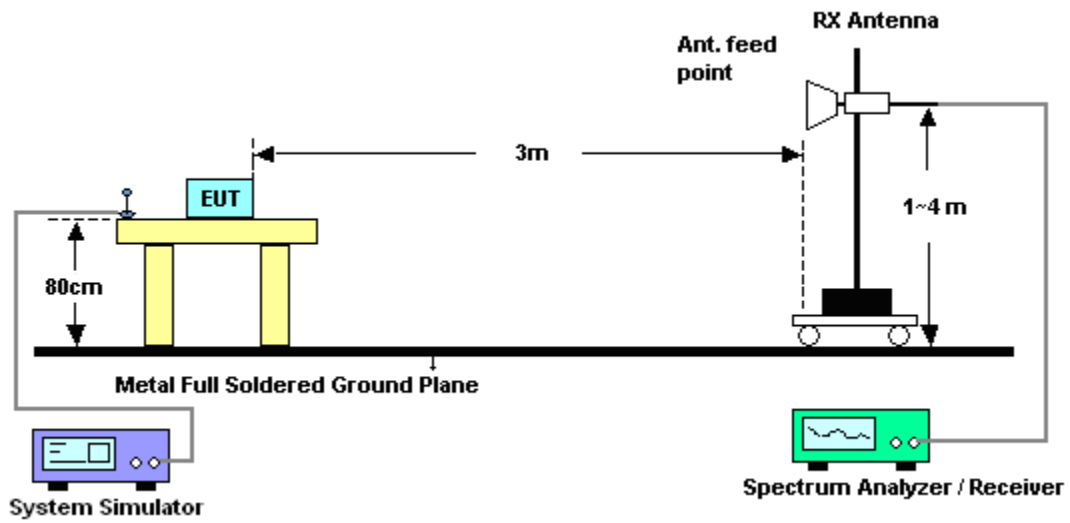



3.3.5 Test Result of ERP/EIRP

LTE Band 4 Radiated Power EIRP for BW 1.4MHz / QPSK				
Horizontal Polarization				
Frequency (MHz)	LVL (dBm)	Correction Factor (dB)	EIRP (dBm)	EIRP (W)
1710.70	-21.41	43.43	22.02	0.16
1732.50	-20.61	43.34	22.73	0.19
1754.30	-20.28	43.65	23.37	0.22
Vertical Polarization				
Frequency (MHz)	LVL (dBm)	Correction Factor (dB)	EIRP (dBm)	EIRP (W)
1710.70	-24.75	46.93	22.18	0.17
1732.50	-23.36	46.19	22.83	0.19
1754.30	-22.26	47.3	25.04	0.32

LTE Band 4 Radiated Power EIRP for BW 1.4MHz / 16QAM				
Horizontal Polarization				
Frequency (MHz)	LVL (dBm)	Correction Factor (dB)	EIRP (dBm)	EIRP (W)
1710.70	-22.77	43.43	20.66	0.12
1732.50	-21.83	43.34	21.51	0.14
1754.30	-21.60	43.65	22.05	0.16
Vertical Polarization				
Frequency (MHz)	LVL (dBm)	Correction Factor (dB)	EIRP (dBm)	EIRP (W)
1710.70	-23.64	46.93	23.29	0.21
1732.50	-22.77	46.19	23.42	0.22
1754.30	-23.48	47.3	23.82	0.24



LTE Band 4 Radiated Power EIRP for BW 3MHz / QPSK				
Horizontal Polarization				
Frequency (MHz)	LVL (dBm)	Correction Factor (dB)	EIRP (dBm)	EIRP (W)
1711.50	-21.56	43.38	21.82	0.15
1732.50	-20.72	43.34	22.62	0.18
1753.50	-20.20	43.51	23.31	0.21
Vertical Polarization				
Frequency (MHz)	LVL (dBm)	Correction Factor (dB)	EIRP (dBm)	EIRP (W)
1711.50	-22.22	46.65	24.43	0.28
1732.50	-21.58	46.19	24.61	0.29
1753.50	-22.76	47.65	24.89	0.31

LTE Band 4 Radiated Power EIRP for BW 3MHz / 16QAM				
Horizontal Polarization				
Frequency (MHz)	LVL (dBm)	Correction Factor (dB)	EIRP (dBm)	EIRP (W)
1711.50	-22.83	43.38	20.55	0.11
1732.50	-21.96	43.34	21.38	0.14
1753.50	-21.57	43.51	21.94	0.16
Vertical Polarization				
Frequency (MHz)	LVL (dBm)	Correction Factor (dB)	EIRP (dBm)	EIRP (W)
1711.50	-23.52	46.65	23.13	0.21
1732.50	-22.89	46.19	23.30	0.21
1753.50	-24.01	47.65	23.64	0.23



LTE Band 4 Radiated Power EIRP for BW 5MHz / QPSK				
Horizontal Polarization				
Frequency (MHz)	LVL (dBm)	Correction Factor (dB)	EIRP (dBm)	EIRP (W)
1712.50	-20.99	42.75	21.76	0.15
1732.50	-20.87	43.34	22.47	0.18
1752.50	-20.03	43.28	23.25	0.21
Vertical Polarization				
Frequency (MHz)	LVL (dBm)	Correction Factor (dB)	EIRP (dBm)	EIRP (W)
1712.50	-21.91	46.26	24.35	0.27
1732.50	-21.59	46.19	24.60	0.29
1752.50	-22.64	47.72	25.08	0.32

LTE Band 4 Radiated Power EIRP for BW 5MHz / 16QAM				
Horizontal Polarization				
Frequency (MHz)	LVL (dBm)	Correction Factor (dB)	EIRP (dBm)	EIRP (W)
1712.50	-21.80	42.75	20.95	0.12
1732.50	-21.92	43.34	21.42	0.14
1752.50	-21.30	43.28	21.98	0.16
Vertical Polarization				
Frequency (MHz)	LVL (dBm)	Correction Factor (dB)	EIRP (dBm)	EIRP (W)
1712.50	-22.93	46.26	23.33	0.22
1732.50	-22.96	46.19	23.23	0.21
1752.50	-23.98	47.72	23.74	0.24



LTE Band 4 Radiated Power EIRP for BW 10MHz / QPSK				
Horizontal Polarization				
Frequency (MHz)	LVL (dBm)	Correction Factor (dB)	EIRP (dBm)	EIRP (W)
1715.00	-20.25	42.22	21.97	0.16
1732.50	-20.77	43.34	22.57	0.18
1750.00	-21.44	44.37	22.93	0.20
Vertical Polarization				
Frequency (MHz)	LVL (dBm)	Correction Factor (dB)	EIRP (dBm)	EIRP (W)
1715.00	-21.32	45.79	24.47	0.28
1732.50	-21.50	46.19	24.69	0.29
1750.00	-22.54	47.21	24.67	0.29

LTE Band 4 Radiated Power EIRP for BW 10MHz / 16QAM				
Horizontal Polarization				
Frequency (MHz)	LVL (dBm)	Correction Factor (dB)	EIRP (dBm)	EIRP (W)
1715.00	-21.45	42.22	20.77	0.12
1732.50	-21.91	43.34	21.43	0.14
1750.00	-22.43	44.37	21.94	0.16
Vertical Polarization				
Frequency (MHz)	LVL (dBm)	Correction Factor (dB)	EIRP (dBm)	EIRP (W)
1715.00	-22.58	45.79	23.21	0.21
1732.50	-22.82	46.19	23.37	0.22
1750.00	-23.49	47.21	23.72	0.24



LTE Band 4 Radiated Power EIRP for BW 15MHz / QPSK				
Horizontal Polarization				
Frequency (MHz)	LVL (dBm)	Correction Factor (dB)	EIRP (dBm)	EIRP (W)
1717.50	-21.09	42.93	21.84	0.15
1732.50	-20.73	43.34	22.61	0.18
1747.50	-20.60	43.58	22.98	0.20
Vertical Polarization				
Frequency (MHz)	LVL (dBm)	Correction Factor (dB)	EIRP (dBm)	EIRP (W)
1717.50	-22.05	46.52	24.47	0.28
1732.50	-21.46	46.19	24.73	0.30
1747.50	-22.12	47.08	24.96	0.31

LTE Band 4 Radiated Power EIRP for BW 15MHz / 16QAM				
Horizontal Polarization				
Frequency (MHz)	LVL (dBm)	Correction Factor (dB)	EIRP (dBm)	EIRP (W)
1717.50	-22.04	42.93	20.89	0.12
1732.50	-22.02	43.34	21.32	0.14
1747.50	-21.83	43.58	21.75	0.15
Vertical Polarization				
Frequency (MHz)	LVL (dBm)	Correction Factor (dB)	EIRP (dBm)	EIRP (W)
1717.50	-23.20	46.52	23.32	0.21
1732.50	-22.96	46.19	23.23	0.21
1747.50	-23.46	47.08	23.62	0.23



LTE Band 4 Radiated Power EIRP for BW 20MHz / QPSK				
Horizontal Polarization				
Frequency (MHz)	LVL (dBm)	Correction Factor (dB)	EIRP (dBm)	EIRP (W)
1720.00	-21.54	43.42	21.88	0.15
1732.50	-20.82	43.34	22.52	0.18
1745.00	-20.83	43.62	22.79	0.19
Vertical Polarization				
Frequency (MHz)	LVL (dBm)	Correction Factor (dB)	EIRP (dBm)	EIRP (W)
1720.00	-21.68	46.18	24.50	0.28
1732.50	-21.45	46.19	24.74	0.30
1745.00	-21.70	46.54	24.84	0.30

LTE Band 4 Radiated Power EIRP for BW 20MHz / 16QAM				
Horizontal Polarization				
Frequency (MHz)	LVL (dBm)	Correction Factor (dB)	EIRP (dBm)	EIRP (W)
1720.00	-22.18	43.42	21.24	0.13
1732.50	-21.82	43.34	21.52	0.14
1745.00	-21.56	43.62	22.06	0.16
Vertical Polarization				
Frequency (MHz)	LVL (dBm)	Correction Factor (dB)	EIRP (dBm)	EIRP (W)
1720.00	-22.79	46.18	23.39	0.22
1732.50	-23.04	46.19	23.15	0.21
1745.00	-22.96	46.54	23.58	0.23



LTE Band 7 Radiated Power EIRP for BW 5MHz / QPSK				
Horizontal Polarization				
Frequency (MHz)	LVL (dBm)	Correction Factor (dB)	EIRP (dBm)	EIRP (W)
2502.50	-21.57	46.44	24.87	0.31
2535.00	-21.12	46.85	25.73	0.37
2567.50	-21.36	46.93	25.57	0.36
Vertical Polarization				
Frequency (MHz)	LVL (dBm)	Correction Factor (dB)	EIRP (dBm)	EIRP (W)
2502.50	-24.33	48.49	24.16	0.26
2535.00	-23.28	47.50	24.22	0.26
2567.50	-24.64	48.26	23.62	0.23

LTE Band 7 Radiated Power EIRP for BW 5MHz / 16QAM				
Horizontal Polarization				
Frequency (MHz)	LVL (dBm)	Correction Factor (dB)	EIRP (dBm)	EIRP (W)
2502.50	-22.81	46.44	23.63	0.23
2535.00	-22.36	46.85	24.49	0.28
2567.50	-22.94	46.93	23.99	0.25
Vertical Polarization				
Frequency (MHz)	LVL (dBm)	Correction Factor (dB)	EIRP (dBm)	EIRP (W)
2502.50	-25.79	48.49	22.70	0.19
2535.00	-24.68	47.50	22.82	0.19
2567.50	-26.14	48.26	22.12	0.16



LTE Band 7 Radiated Power EIRP for BW 10MHz / QPSK				
Horizontal Polarization				
Frequency (MHz)	LVL (dBm)	Correction Factor (dB)	EIRP (dBm)	EIRP (W)
2505.00	-21.46	46.38	24.92	0.31
2535.00	-21.12	46.85	25.73	0.37
2565.00	-21.25	46.89	25.64	0.37
Vertical Polarization				
Frequency (MHz)	LVL (dBm)	Correction Factor (dB)	EIRP (dBm)	EIRP (W)
2505.00	-24.20	48.26	24.06	0.25
2535.00	-23.40	47.50	24.10	0.26
2565.00	-24.40	48.10	23.70	0.23

LTE Band 7 Radiated Power EIRP for BW 10MHz / 16QAM				
Horizontal Polarization				
Frequency (MHz)	LVL (dBm)	Correction Factor (dB)	EIRP (dBm)	EIRP (W)
2505.00	-22.94	46.38	23.44	0.22
2535.00	-22.29	46.85	24.56	0.29
2565.00	-22.72	46.89	24.17	0.26
Vertical Polarization				
Frequency (MHz)	LVL (dBm)	Correction Factor (dB)	EIRP (dBm)	EIRP (W)
2505.00	-25.71	48.26	22.55	0.18
2535.00	-24.72	47.50	22.78	0.19
2565.00	-26.01	48.10	22.09	0.16



LTE Band 7 Radiated Power EIRP for BW 15MHz / QPSK				
Horizontal Polarization				
Frequency (MHz)	LVL (dBm)	Correction Factor (dB)	EIRP (dBm)	EIRP (W)
2507.50	-21.53	46.51	24.98	0.31
2535.00	-21.22	46.85	25.63	0.37
2562.50	-20.80	46.44	25.64	0.37
Vertical Polarization				
Frequency (MHz)	LVL (dBm)	Correction Factor (dB)	EIRP (dBm)	EIRP (W)
2507.50	-23.69	47.86	24.17	0.26
2535.00	-23.28	47.50	24.22	0.26
2562.50	-24.24	48.09	23.85	0.24

LTE Band 7 Radiated Power EIRP for BW 15MHz / 16QAM				
Horizontal Polarization				
Frequency (MHz)	LVL (dBm)	Correction Factor (dB)	EIRP (dBm)	EIRP (W)
2507.50	-22.89	46.51	23.62	0.23
2535.00	-22.32	46.85	24.53	0.28
2562.50	-22.36	46.44	24.08	0.26
Vertical Polarization				
Frequency (MHz)	LVL (dBm)	Correction Factor (dB)	EIRP (dBm)	EIRP (W)
2507.50	-25.23	47.86	22.63	0.18
2535.00	-24.72	47.50	22.78	0.19
2562.50	-26.12	48.09	21.97	0.16



LTE Band 7 Radiated Power EIRP for BW 20MHz / QPSK				
Horizontal Polarization				
Frequency (MHz)	LVL (dBm)	Correction Factor (dB)	EIRP (dBm)	EIRP (W)
2510.00	-21.60	46.54	24.94	0.31
2535.00	-21.33	46.85	25.52	0.36
2560.00	-20.65	46.49	25.84	0.38
Vertical Polarization				
Frequency (MHz)	LVL (dBm)	Correction Factor (dB)	EIRP (dBm)	EIRP (W)
2510.00	-23.62	47.75	24.13	0.26
2535.00	-23.34	47.50	24.16	0.26
2560.00	-24.36	48.43	24.07	0.26

LTE Band 7 Radiated Power EIRP for BW 20MHz / 16QAM				
Horizontal Polarization				
Frequency (MHz)	LVL (dBm)	Correction Factor (dB)	EIRP (dBm)	EIRP (W)
2510.00	-22.73	46.54	23.81	0.24
2535.00	-22.45	46.85	24.40	0.28
2560.00	-22.31	46.49	24.18	0.26
Vertical Polarization				
Frequency (MHz)	LVL (dBm)	Correction Factor (dB)	EIRP (dBm)	EIRP (W)
2510.00	-25.03	47.75	22.72	0.19
2535.00	-24.84	47.50	22.66	0.18
2560.00	-26.39	48.43	22.04	0.16

3.4 Occupied Bandwidth

3.4.1 Description of Occupied Bandwidth Measurement

The occupied bandwidth is the width of a frequency band such that, below the lower and above the upper frequency limits, the mean powers emitted are each equal to a specified percentage 0.5% of the total mean transmitted power.

The 26 dB emission bandwidth is defined as the frequency range between two points, one above and one below the carrier frequency, at which the spectral density of the emission is attenuated 26 dB below the maximum in-band spectral density of the modulated signal. Spectral density (power per unit bandwidth) is to be measured with a detector of resolution bandwidth equal to approximately 1.0% of the emission bandwidth.

3.4.2 Measuring Instruments

The measuring equipment is listed in the section 4 of this test report.

3.4.3 Test Procedures

1. The EUT was connected to spectrum analyzer and system simulator via a power divider.
2. The 26dB and 99% occupied bandwidth (BW) of the middle channel for the highest RF power with full RB sizes were measured.

3.4.4 Test Setup

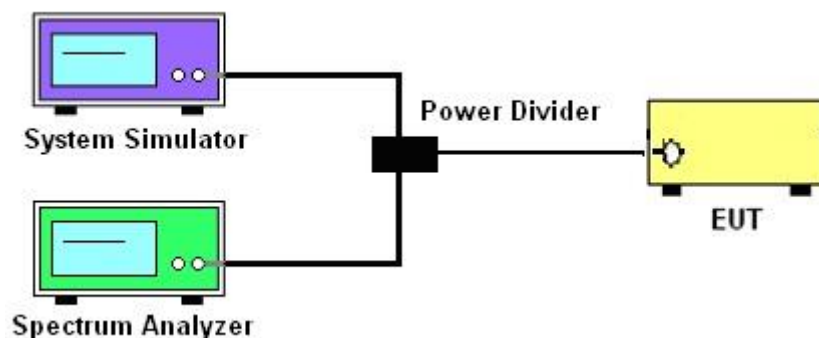



3.4.5 Test Result (Plots) of Occupied Bandwidth

Band :	LTE Band 4	BW / Mod. :	1.4MHz / QPSK
--------	------------	-------------	---------------

99% Occupied Bandwidth Plot on Channel 1957

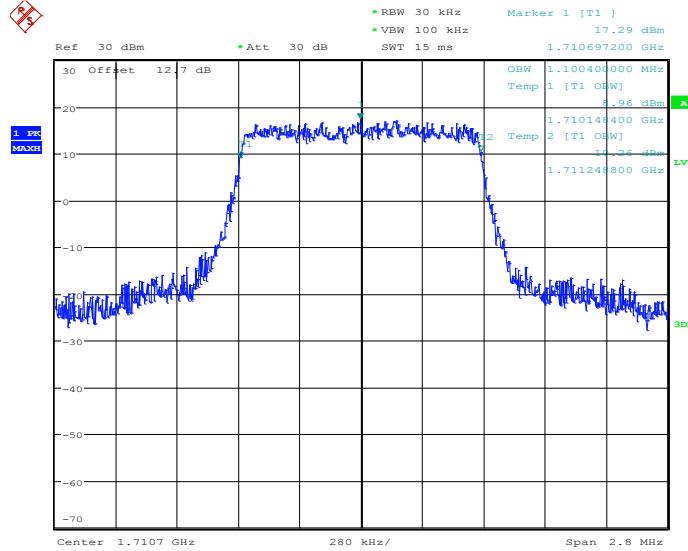

Date: 3.JUN.2014 21:30:51

26dB Bandwidth Plot on Channel 1957

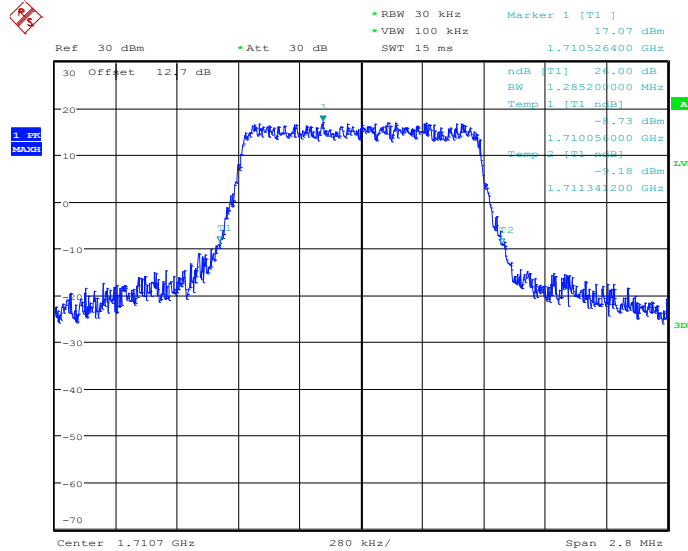

Date: 3.JUN.2014 21:31:26



99% Occupied Bandwidth Plot on Channel 20175

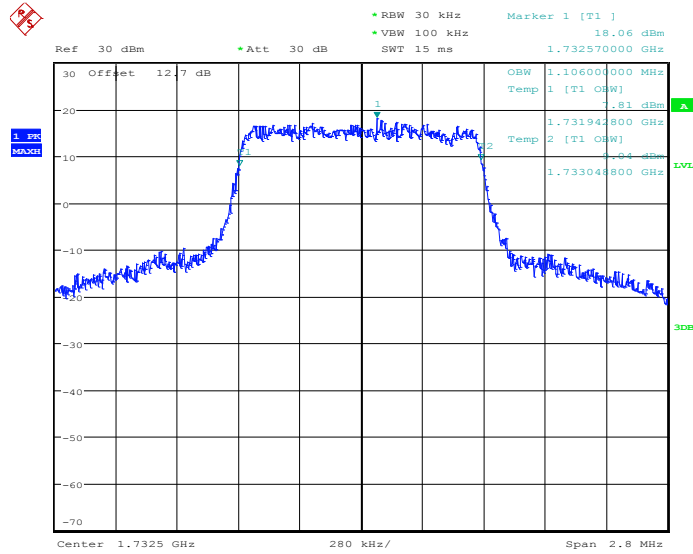

Date: 3.JUN.2014 21:37:15

26dB Bandwidth Plot on Channel 20175

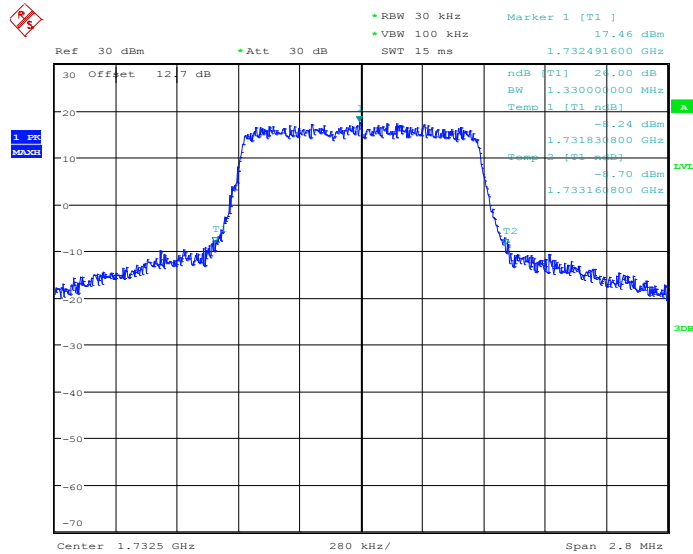

Date: 3.JUN.2014 21:37:50



99% Occupied Bandwidth Plot on Channel 20393

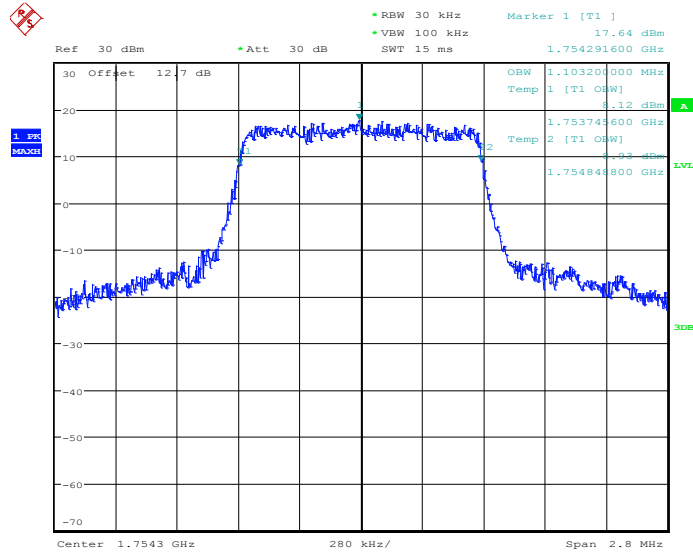

Date: 3.JUN.2014 21:40:27

26dB Bandwidth Plot on Channel 20393

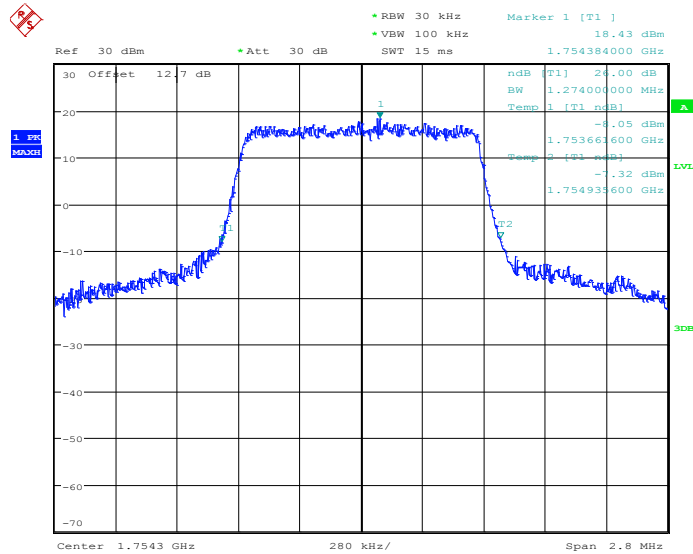

Date: 3.JUN.2014 21:41:02



Band :	LTE Band 4	BW / Mod. :	1.4MHz / 16QAM
---------------	------------	--------------------	----------------

99% Occupied Bandwidth Plot on Channel 1957

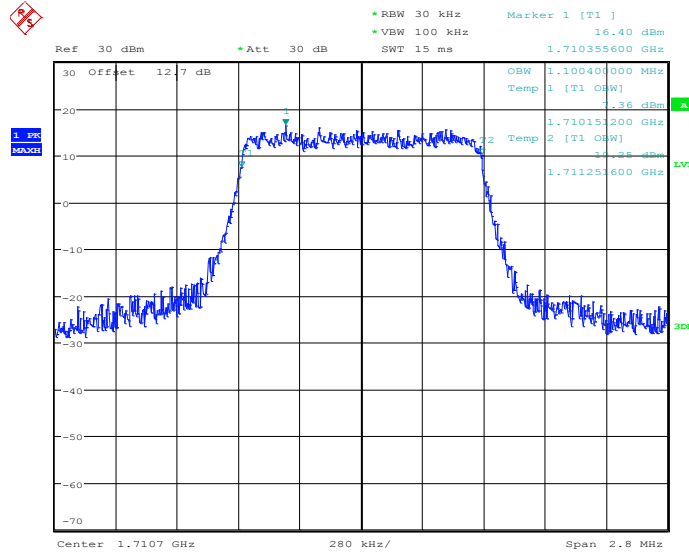

Date: 3.JUN.2014 21:31:07

26dB Bandwidth Plot on Channel 1957

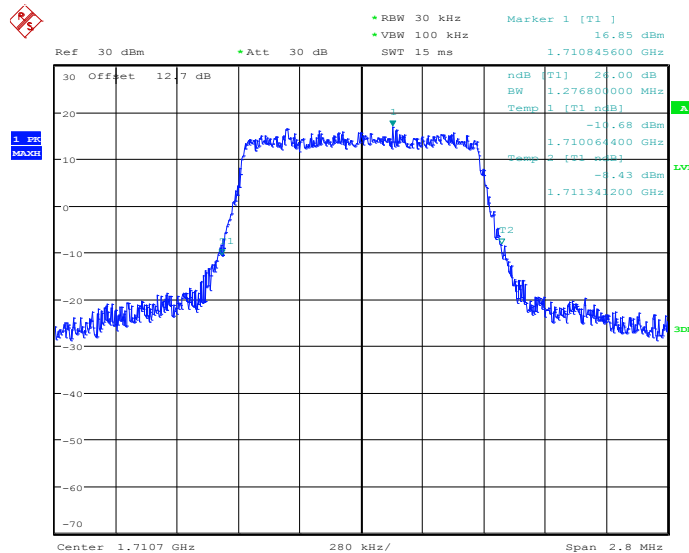

Date: 3.JUN.2014 21:31:44



99% Occupied Bandwidth Plot on Channel 20175

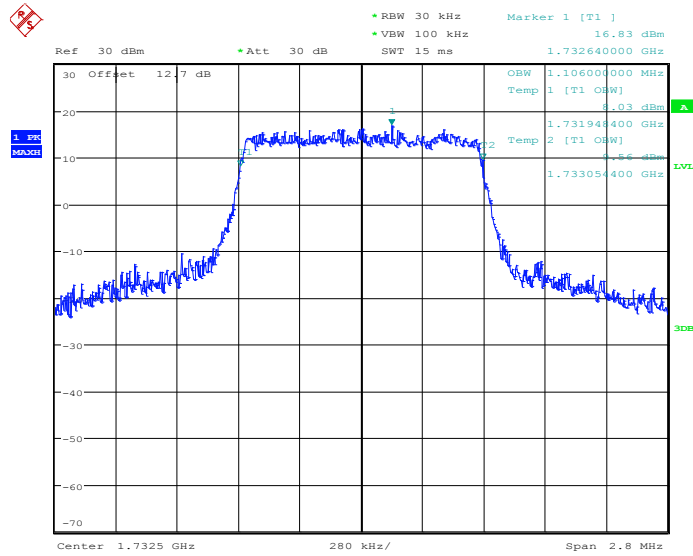

Date: 3.JUN.2014 21:37:31

26dB Bandwidth Plot on Channel 20175

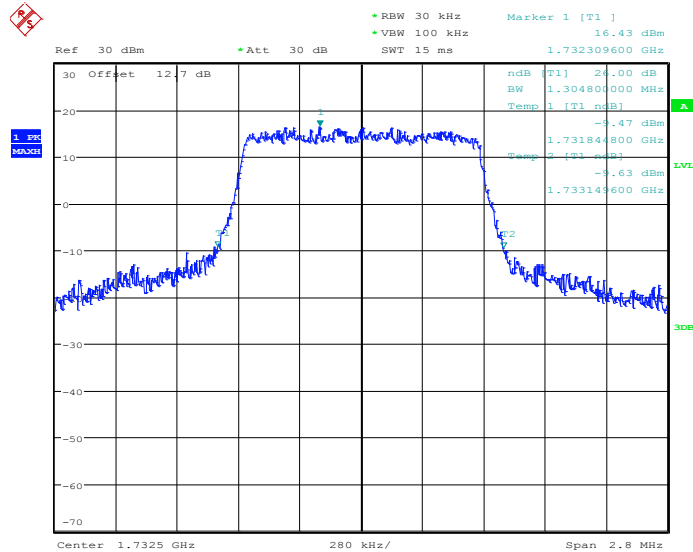

Date: 3.JUN.2014 21:38:08



99% Occupied Bandwidth Plot on Channel 20393

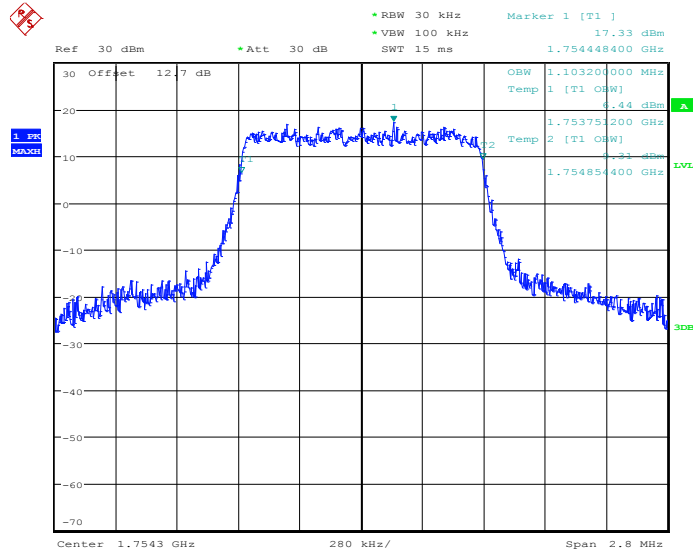

Date: 3.JUN.2014 21:40:43

26dB Bandwidth Plot on Channel 20393

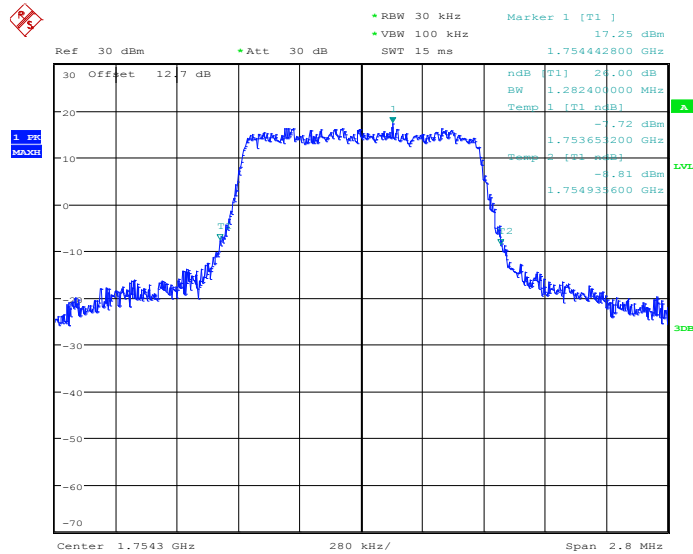

Date: 3.JUN.2014 21:41:20



Band :	LTE Band 4	BW / Mod. :	3MHz / QPSK
---------------	------------	--------------------	-------------

99% Occupied Bandwidth Plot on Channel 19965

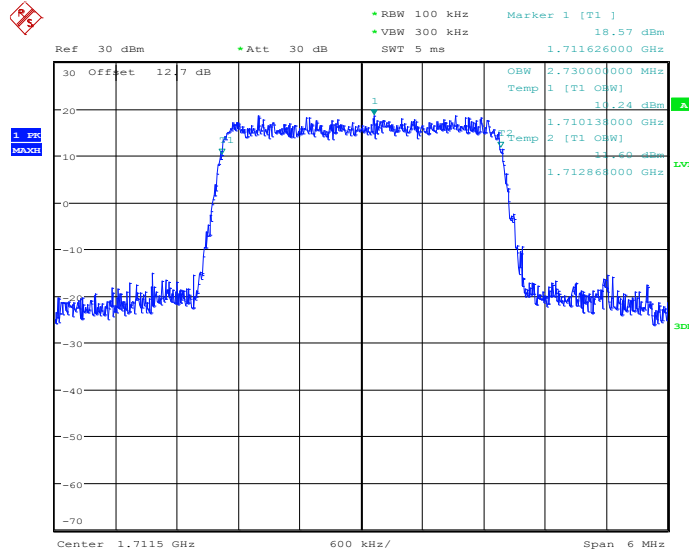

Date: 3.JUN.2014 22:14:08

26dB Bandwidth Plot on Channel 19965

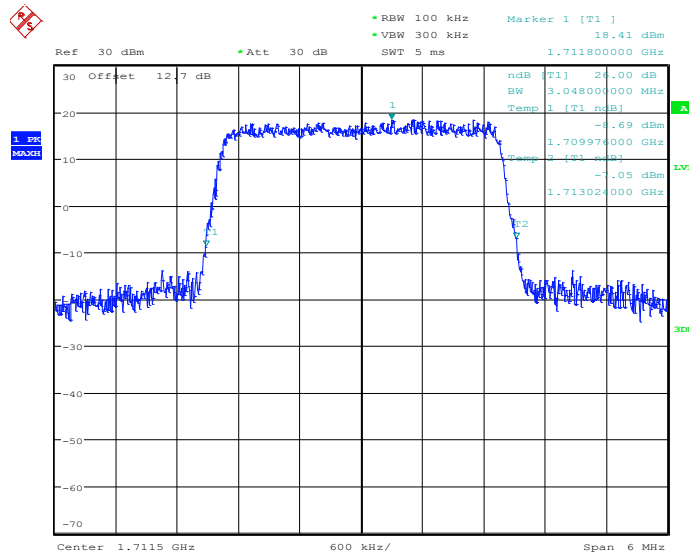

Date: 3.JUN.2014 22:14:44



99% Occupied Bandwidth Plot on Channel 20175

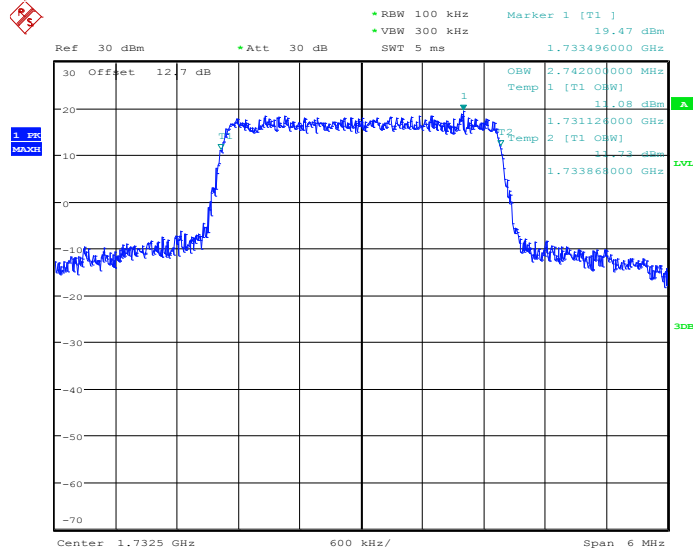

Date: 3.JUN.2014 22:20:33

26dB Bandwidth Plot on Channel 20175

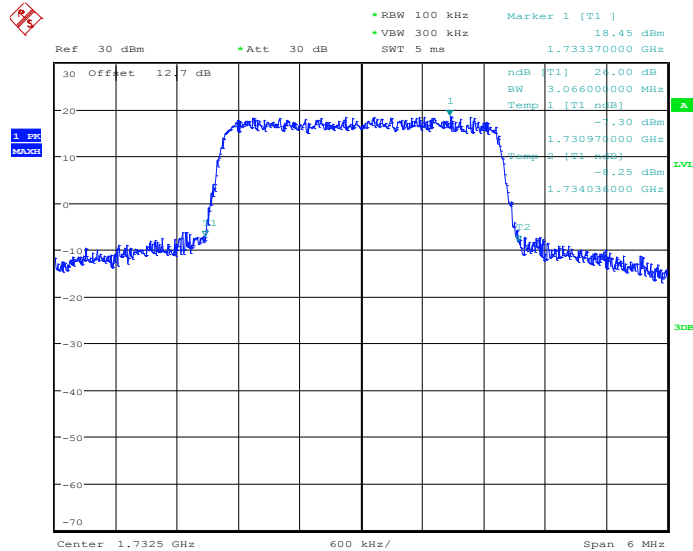

Date: 3.JUN.2014 22:21:08



99% Occupied Bandwidth Plot on Channel 20385

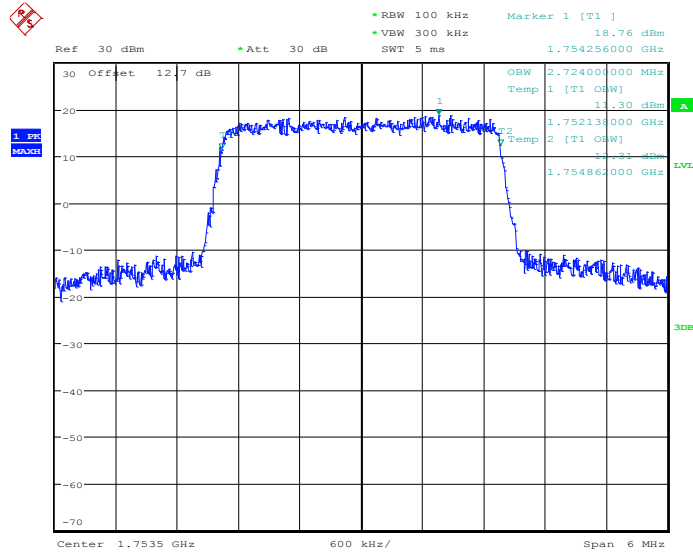

Date: 3.JUN.2014 22:23:46

26dB Bandwidth Plot on Channel 20385

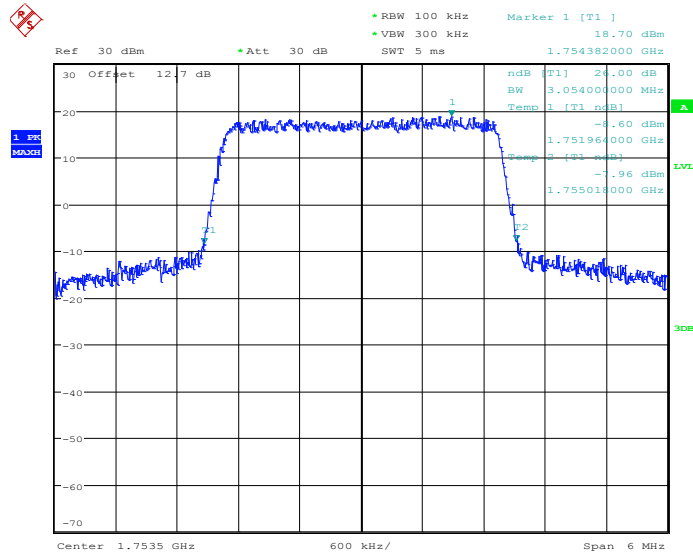

Date: 3.JUN.2014 22:24:21



Band :	LTE Band 4	BW / Mod. :	3MHz / 16QAM
---------------	------------	--------------------	--------------

99% Occupied Bandwidth Plot on Channel 19965

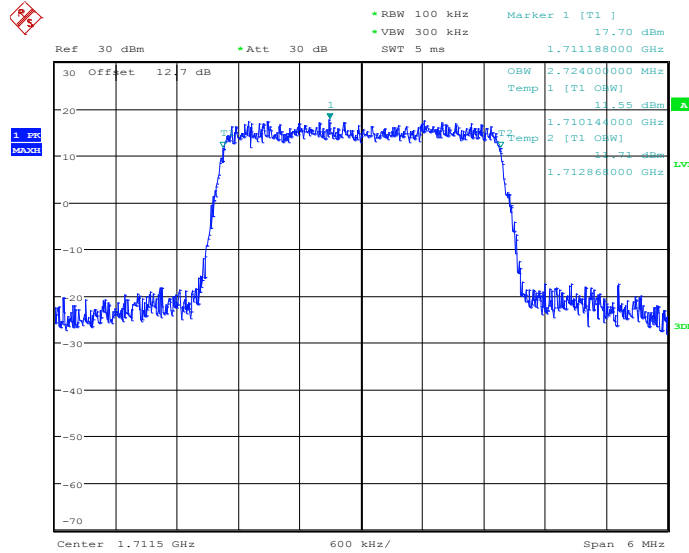

Date: 3.JUN.2014 22:14:26

26dB Bandwidth Plot on Channel 19965

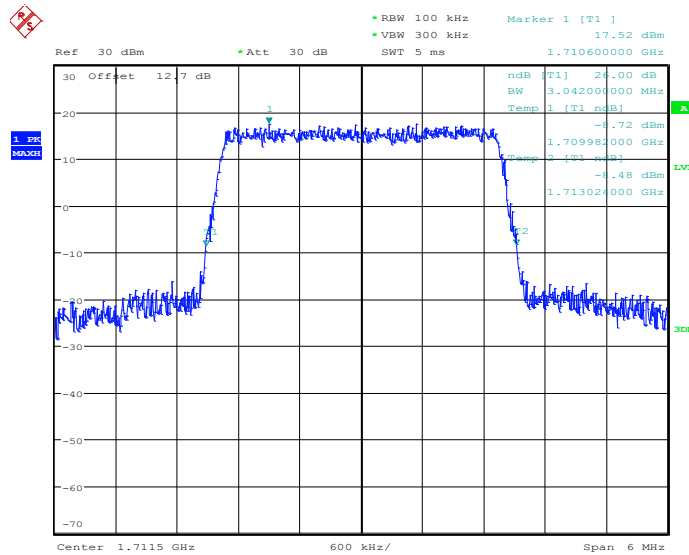

Date: 3.JUN.2014 22:15:02



99% Occupied Bandwidth Plot on Channel 20175

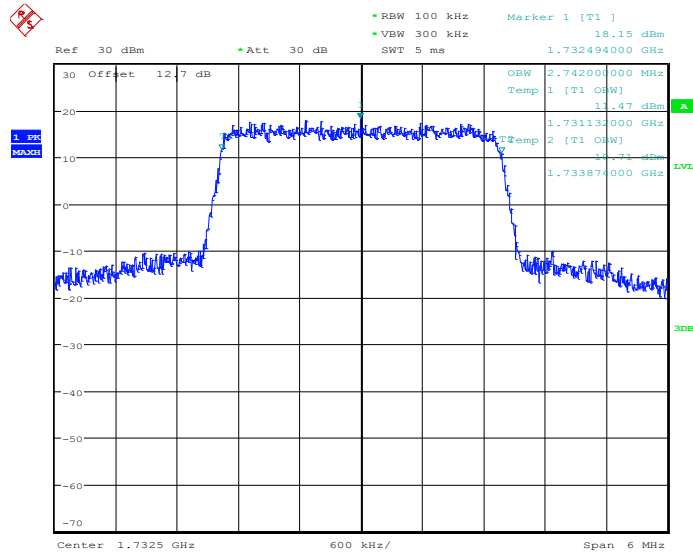

Date: 3.JUN.2014 22:20:50

26dB Bandwidth Plot on Channel 20175

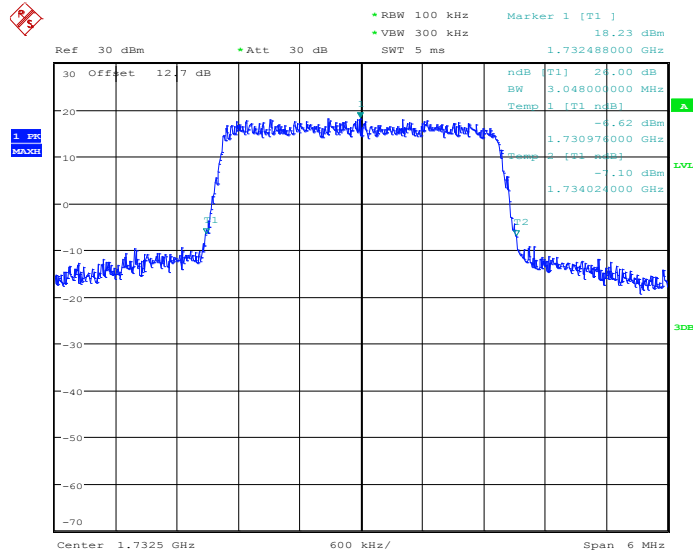

Date: 3.JUN.2014 22:21:27



99% Occupied Bandwidth Plot on Channel 20385

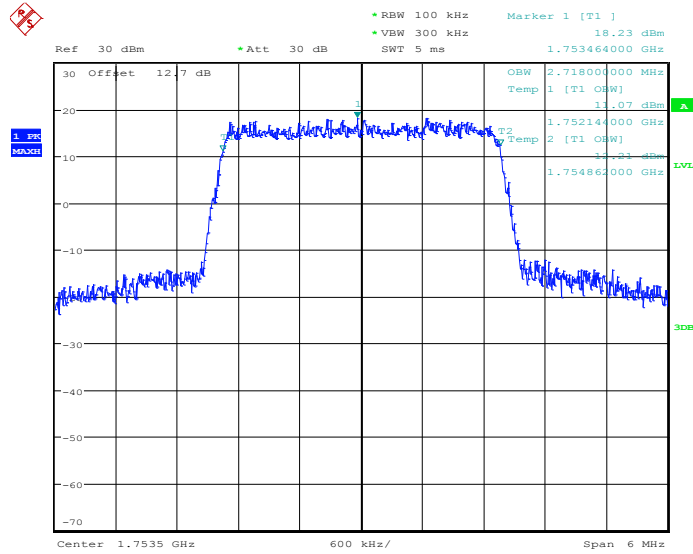

Date: 3.JUN.2014 22:24:02

26dB Bandwidth Plot on Channel 20385

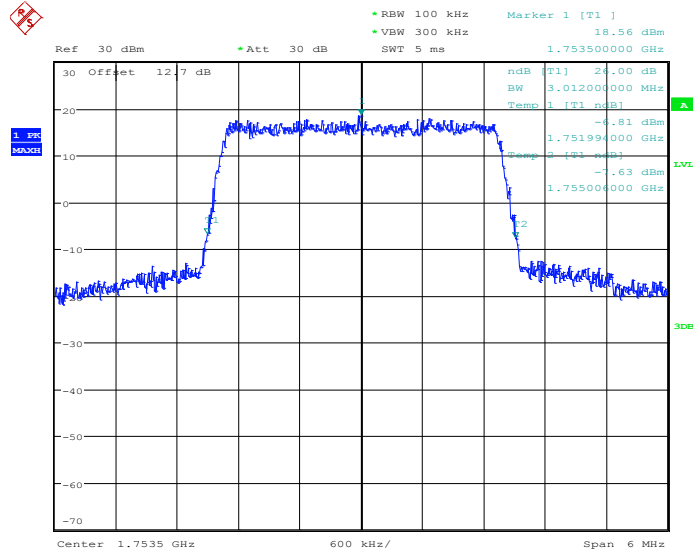

Date: 3.JUN.2014 22:24:39



Band :	LTE Band 4	BW / Mod. :	5MHz / QPSK
---------------	------------	--------------------	-------------

99% Occupied Bandwidth Plot on Channel 19975

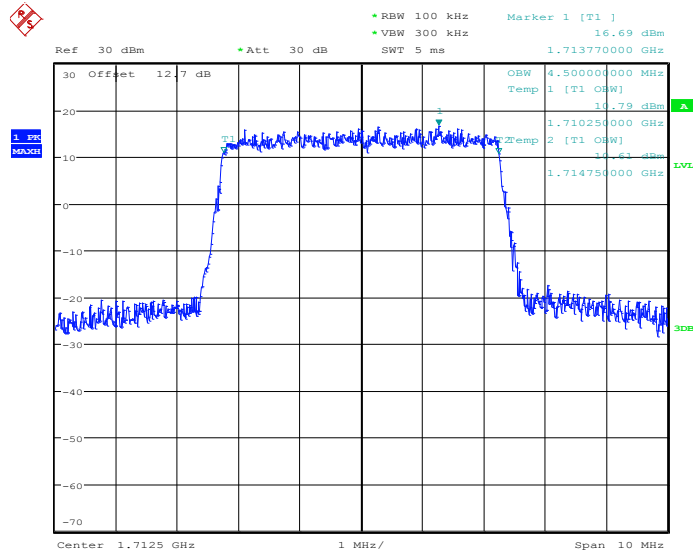

Date: 3.JUN.2014 22:30:14

26dB Bandwidth Plot on Channel 19975

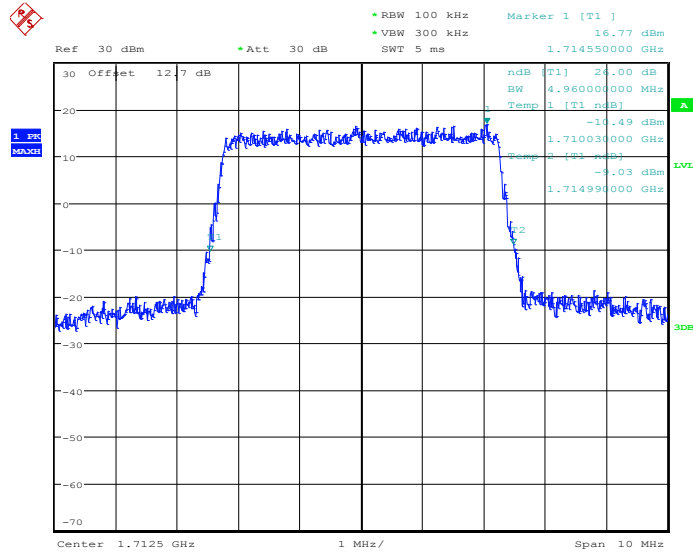

Date: 3.JUN.2014 22:30:49



99% Occupied Bandwidth Plot on Channel 20175

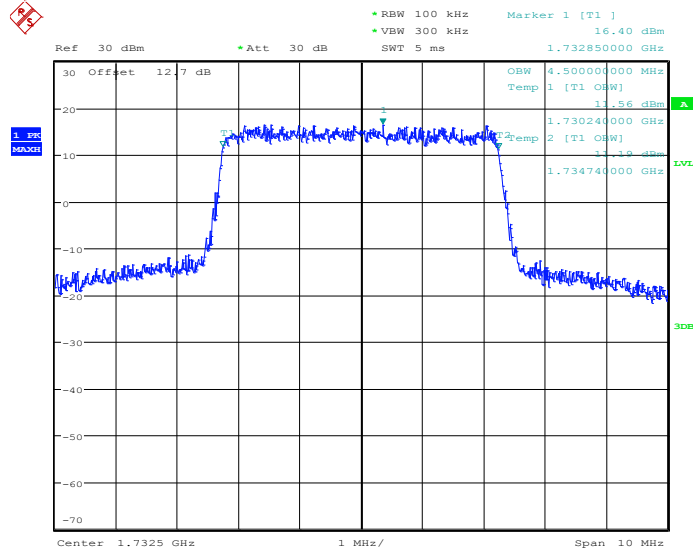

Date: 3.JUN.2014 22:36:37

26dB Bandwidth Plot on Channel 20175

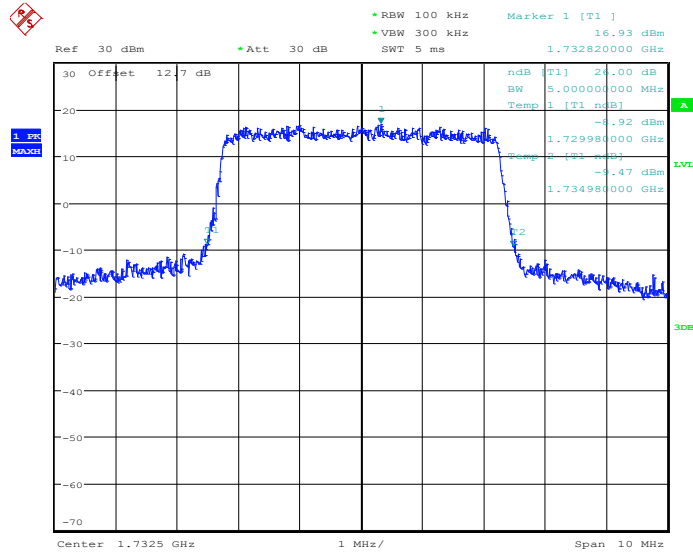

Date: 3.JUN.2014 22:37:12



99% Occupied Bandwidth Plot on Channel 20375

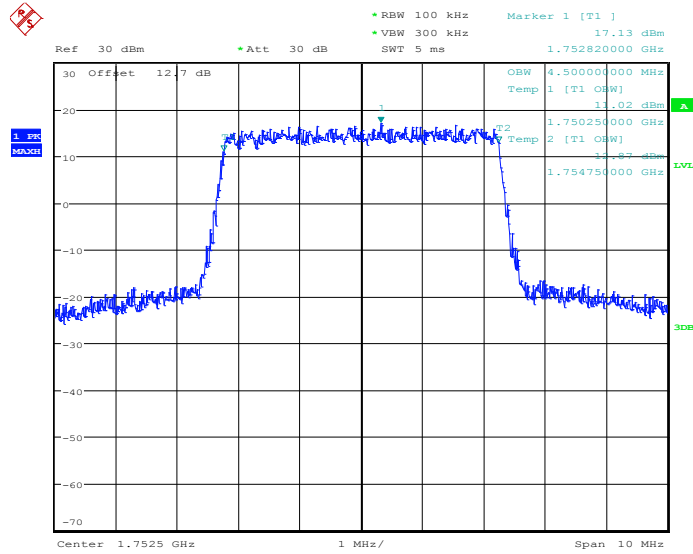

Date: 3.JUN.2014 22:39:49

26dB Bandwidth Plot on Channel 20375

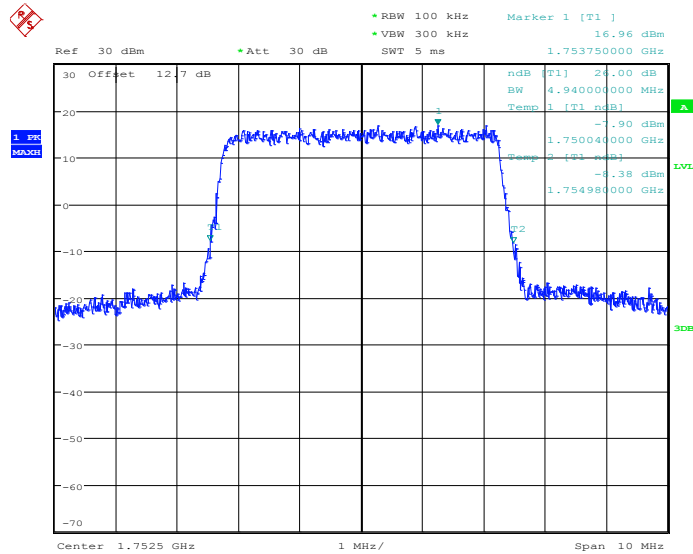

Date: 3.JUN.2014 22:40:26



Band :	LTE Band 4	BW / Mod. :	5MHz / 16QAM
--------	------------	-------------	--------------

99% Occupied Bandwidth Plot on Channel 19975

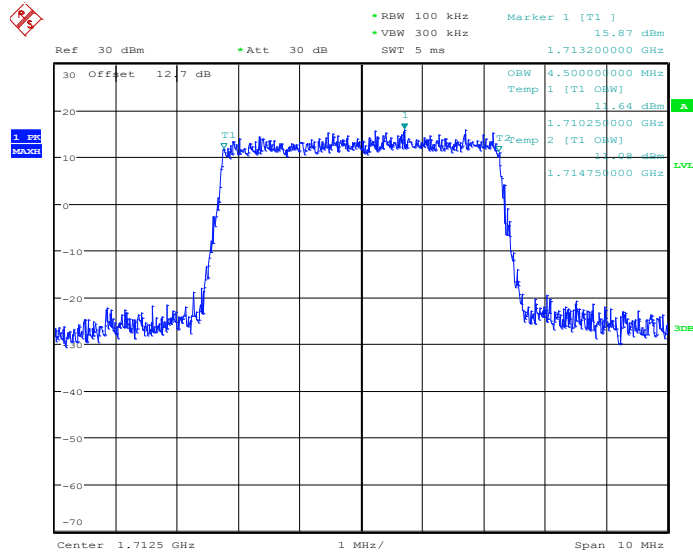

Date: 3.JUN.2014 22:30:30

26dB Bandwidth Plot on Channel 19975

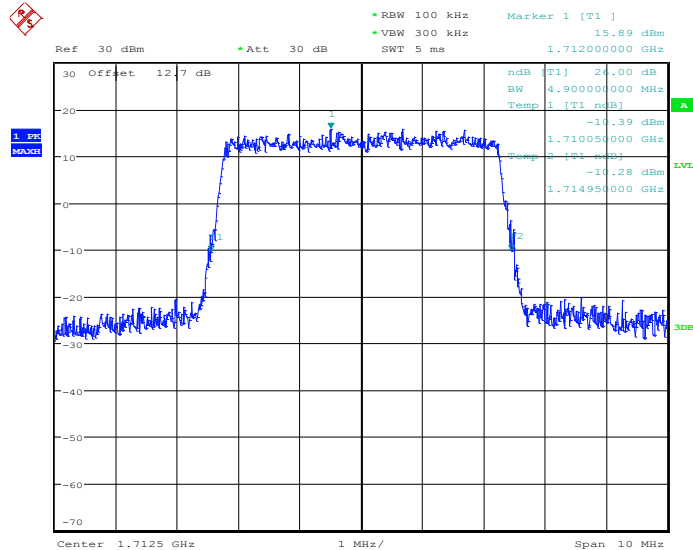

Date: 3.JUN.2014 22:31:07



99% Occupied Bandwidth Plot on Channel 20175

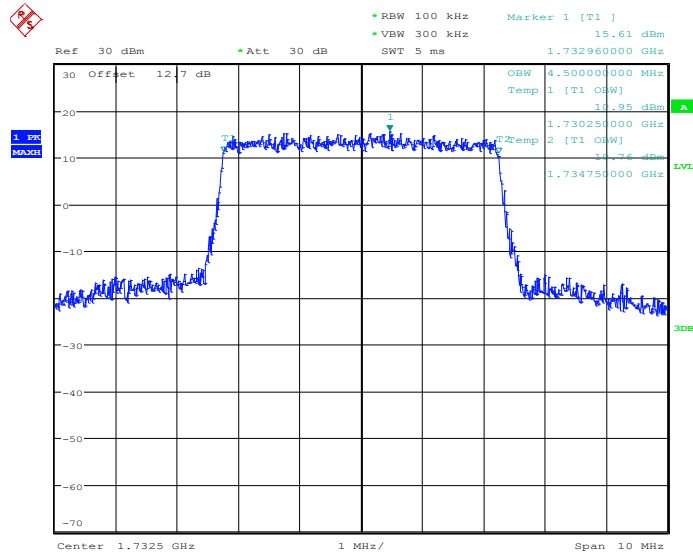

Date: 3.JUN.2014 22:36:54

26dB Bandwidth Plot on Channel 20175

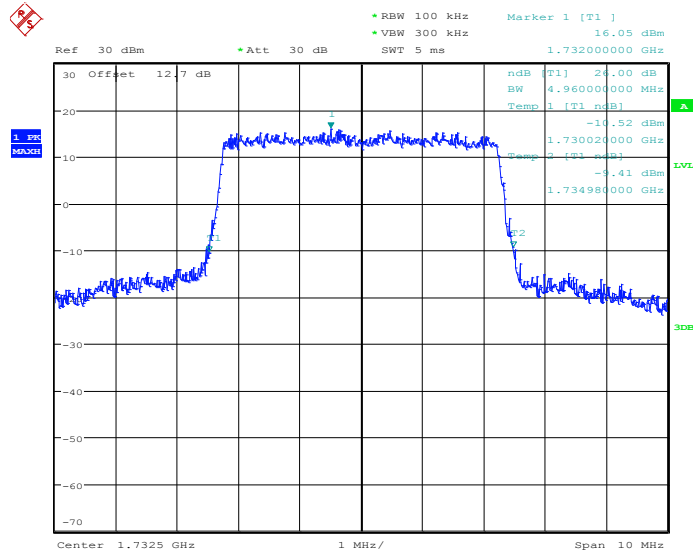

Date: 3.JUN.2014 22:37:31



99% Occupied Bandwidth Plot on Channel 20375

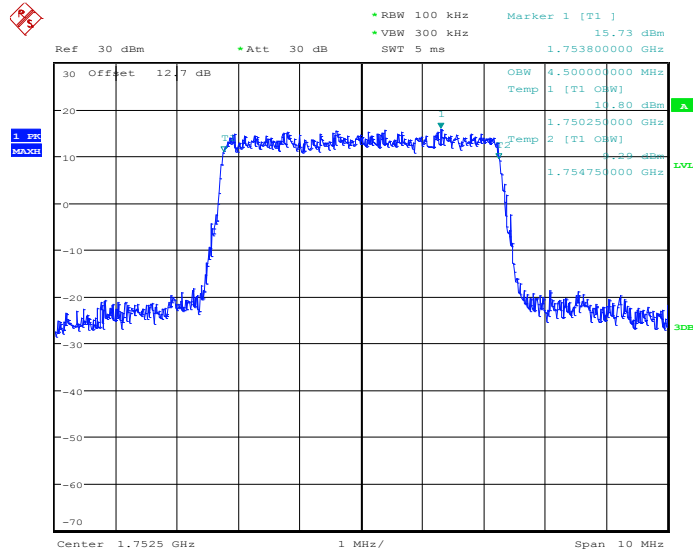

Date: 3.JUN.2014 22:40:06

26dB Bandwidth Plot on Channel 20375

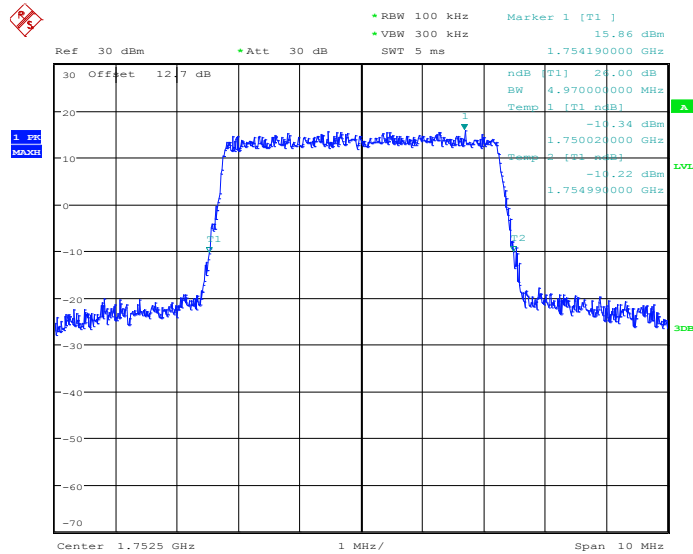

Date: 3.JUN.2014 22:40:45



Band :	LTE Band 4	BW / Mod. :	10MHz / QPSK
--------	------------	-------------	--------------

99% Occupied Bandwidth Plot on Channel 20000

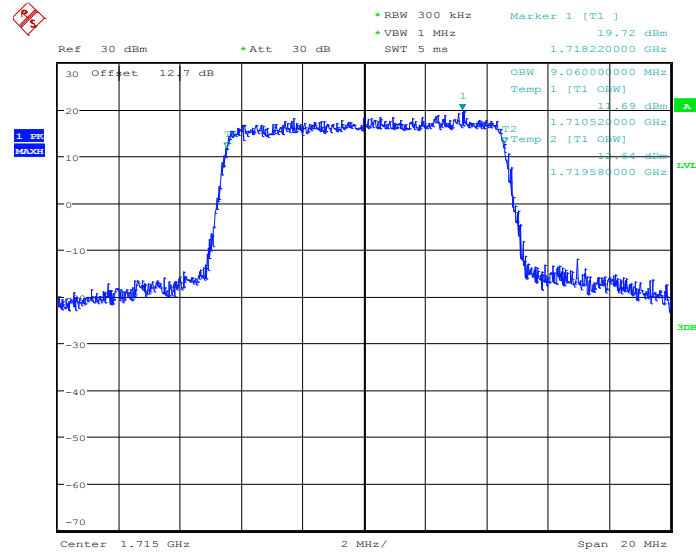

Date: 3.JUN.2014 22:46:20

26dB Bandwidth Plot on Channel 20000

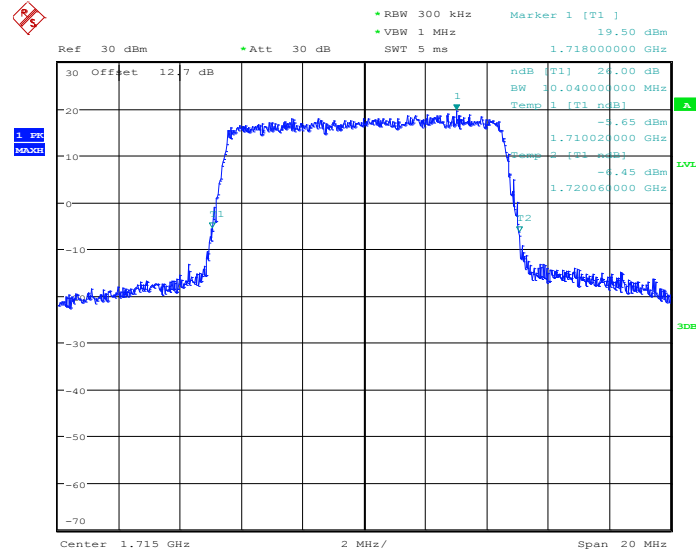

Date: 3.JUN.2014 22:46:55



99% Occupied Bandwidth Plot on Channel 20175

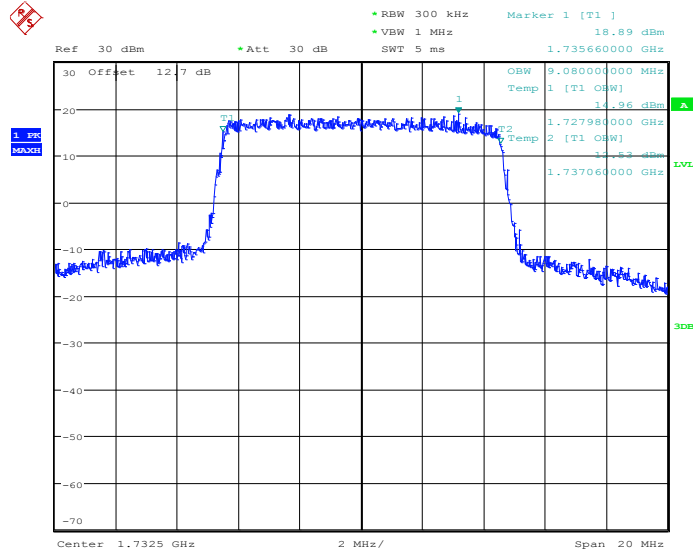

Date: 3.JUN.2014 22:52:44

26dB Bandwidth Plot on Channel 20175

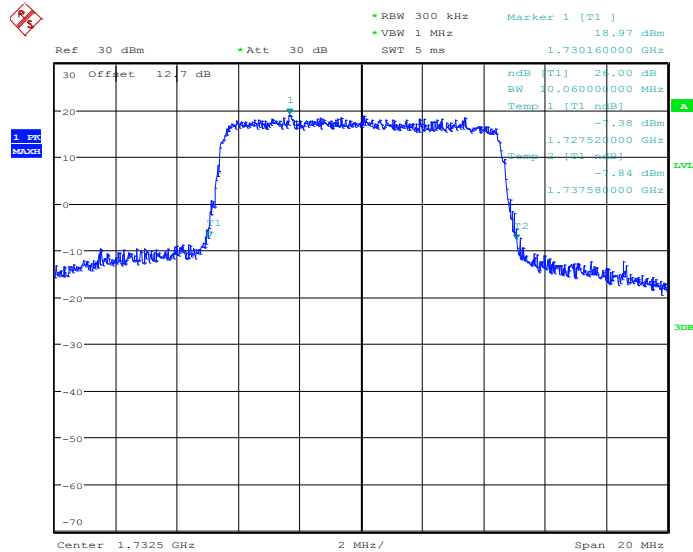

Date: 3.JUN.2014 22:53:19



99% Occupied Bandwidth Plot on Channel 20350

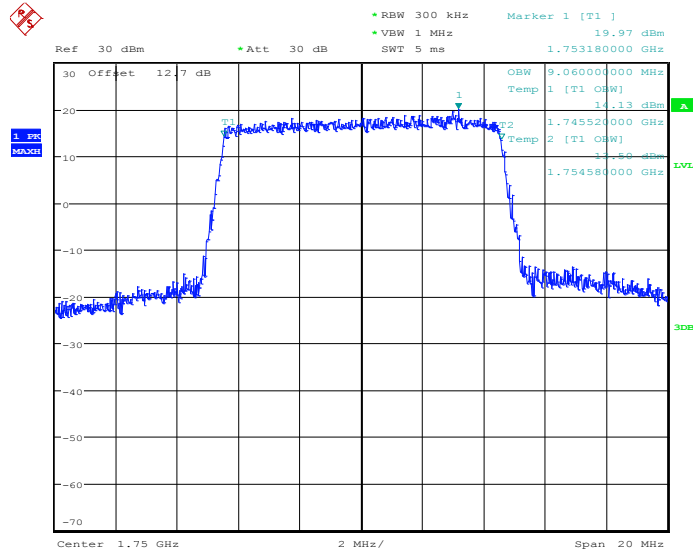

Date: 3.JUN.2014 22:55:57

26dB Bandwidth Plot on Channel 20350

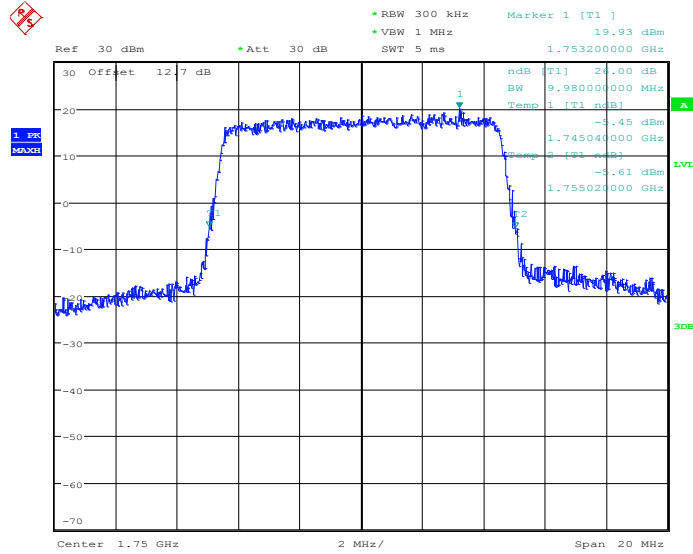

Date: 3.JUN.2014 22:56:32



Band :	LTE Band 4	BW / Mod. :	10MHz / 16QAM
---------------	------------	--------------------	---------------

99% Occupied Bandwidth Plot on Channel 20000

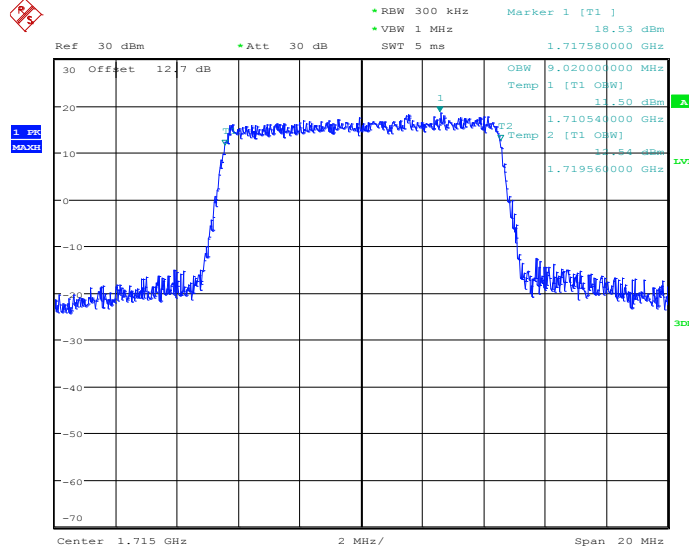

Date: 3.JUN.2014 22:46:36

26dB Bandwidth Plot on Channel 20000

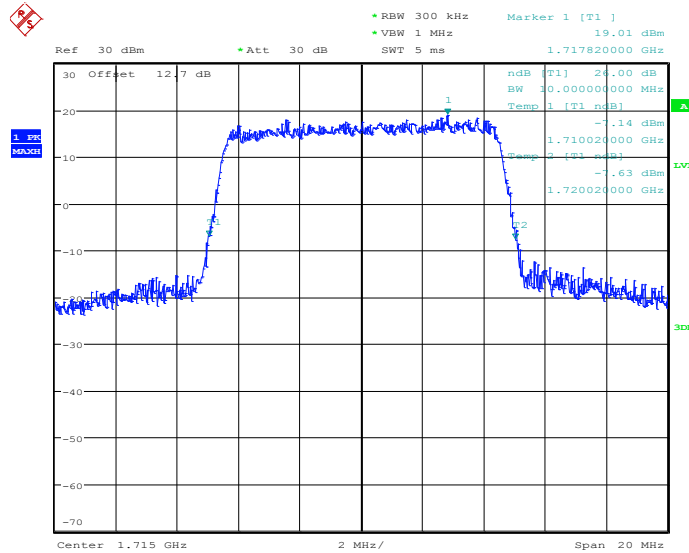

Date: 3.JUN.2014 22:47:13



99% Occupied Bandwidth Plot on Channel 20175

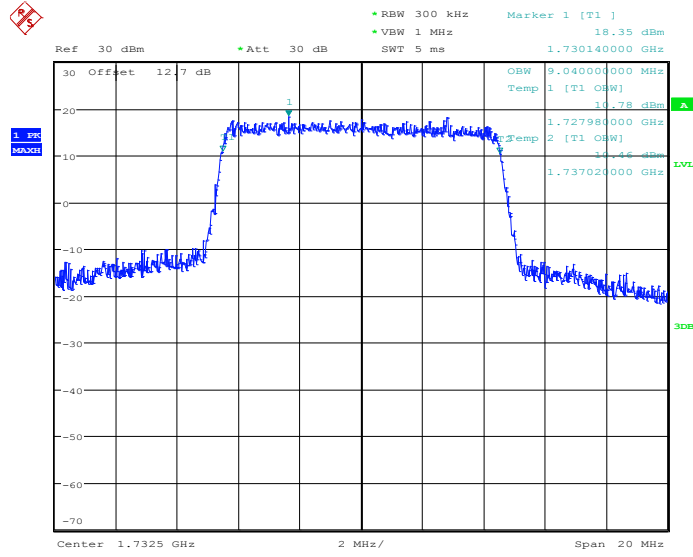

Date: 3.JUN.2014 22:53:01

26dB Bandwidth Plot on Channel 20175

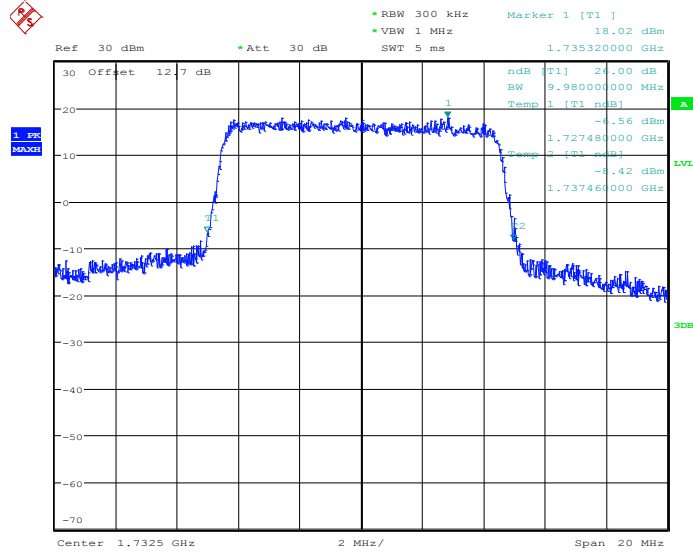

Date: 3.JUN.2014 22:53:38



99% Occupied Bandwidth Plot on Channel 20350

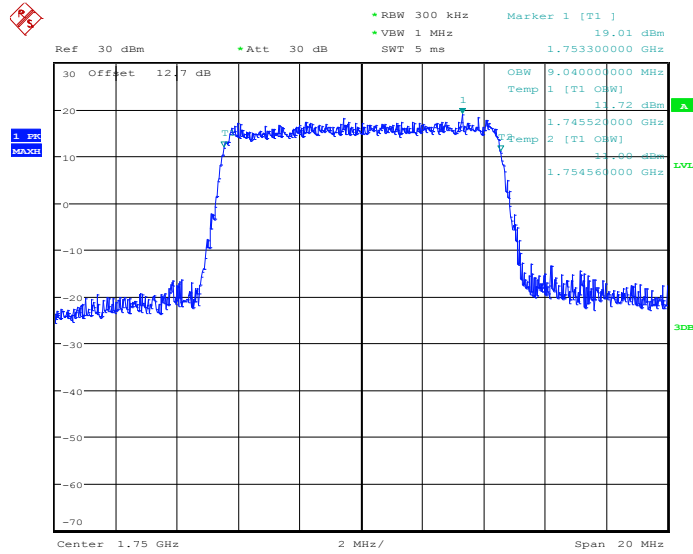

Date: 3.JUN.2014 22:56:13

26dB Bandwidth Plot on Channel 20350

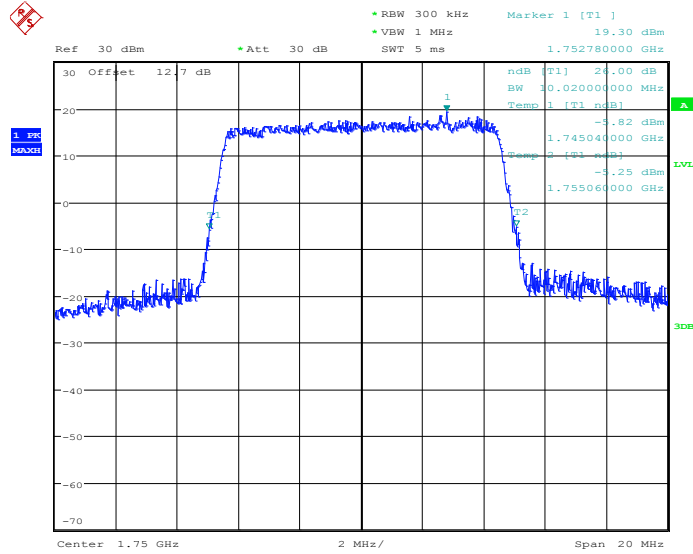

Date: 3.JUN.2014 22:56:51



Band :	LTE Band 4	BW / Mod. :	15MHz / QPSK
---------------	------------	--------------------	--------------

99% Occupied Bandwidth Plot on Channel 2025

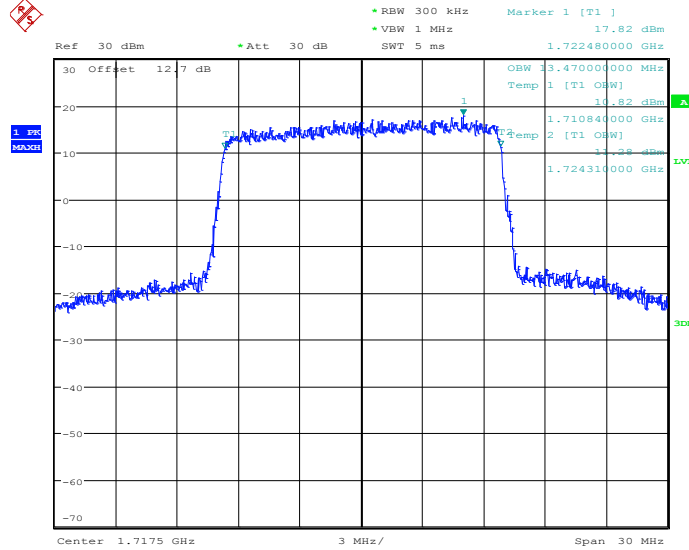

Date: 3.JUN.2014 23:02:26

26dB Bandwidth Plot on Channel 2025

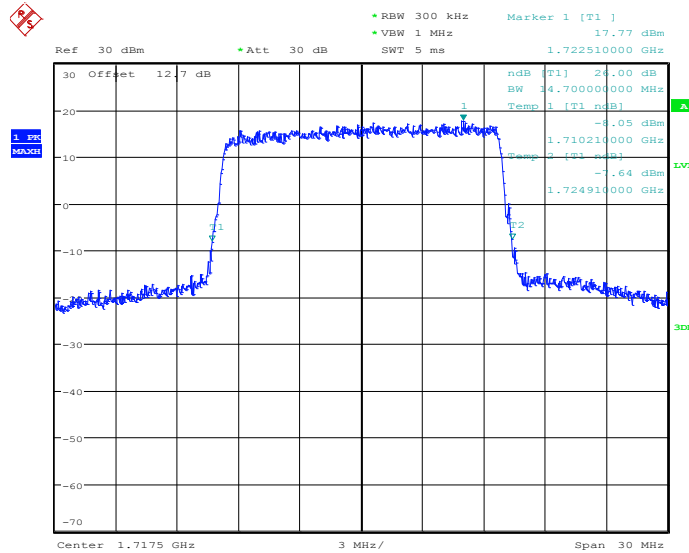

Date: 3.JUN.2014 23:03:01



99% Occupied Bandwidth Plot on Channel 20175

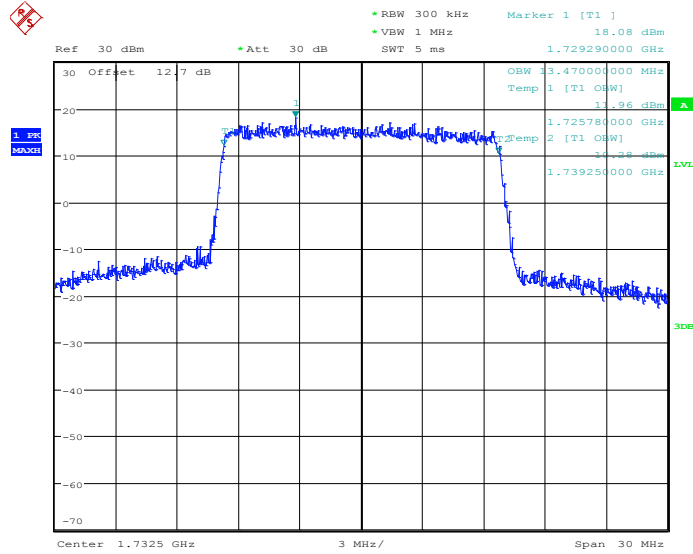

Date: 3.JUN.2014 23:08:50

26dB Bandwidth Plot on Channel 20175

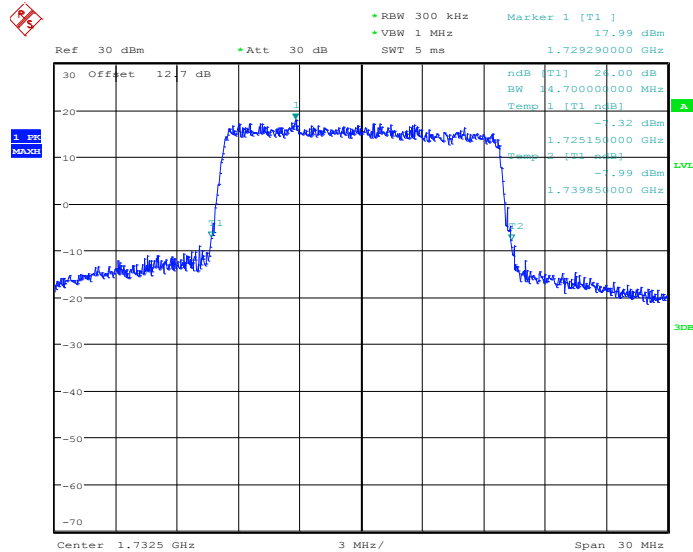

Date: 3.JUN.2014 23:09:25



99% Occupied Bandwidth Plot on Channel 20325

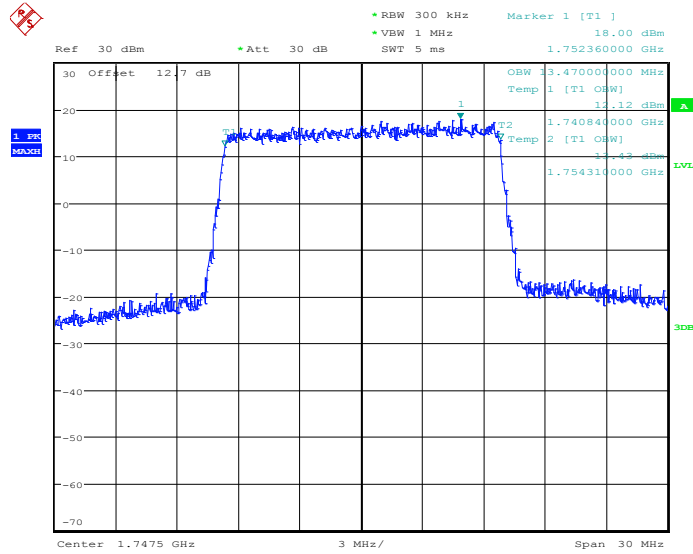

Date: 3.JUN.2014 23:12:03

26dB Bandwidth Plot on Channel 20325

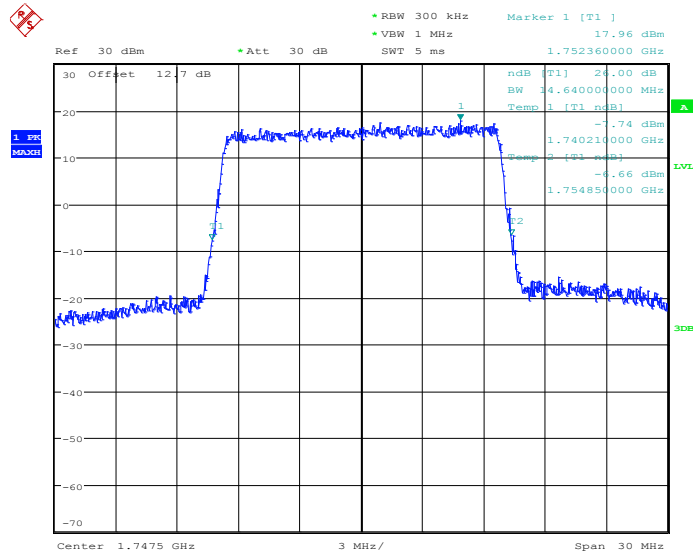

Date: 3.JUN.2014 23:12:38



Band :	LTE Band 4	BW / Mod. :	15MHz / 16QAM
---------------	------------	--------------------	---------------

99% Occupied Bandwidth Plot on Channel 2025

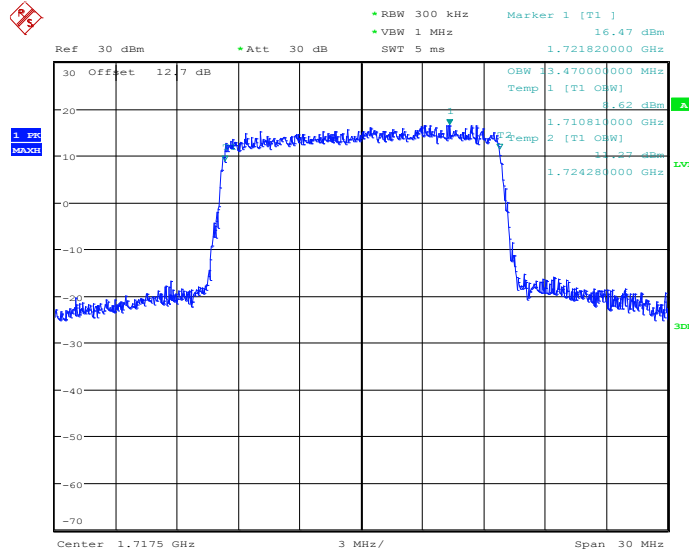

Date: 3.JUN.2014 23:02:42

26dB Bandwidth Plot on Channel 2025

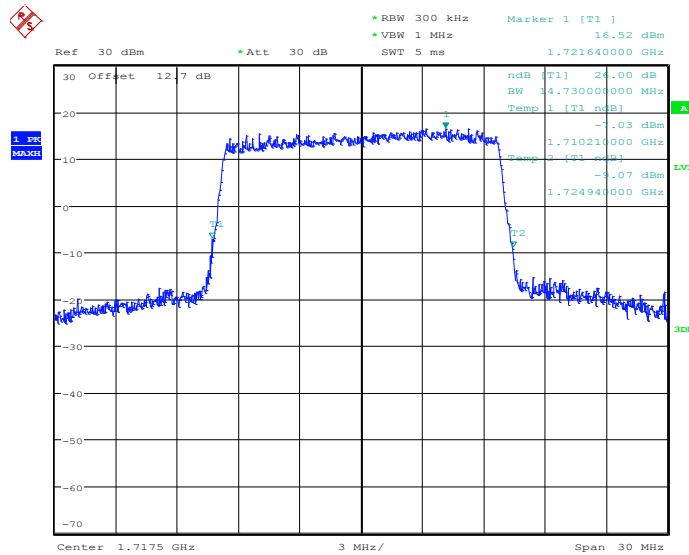

Date: 3.JUN.2014 23:03:19



99% Occupied Bandwidth Plot on Channel 20175

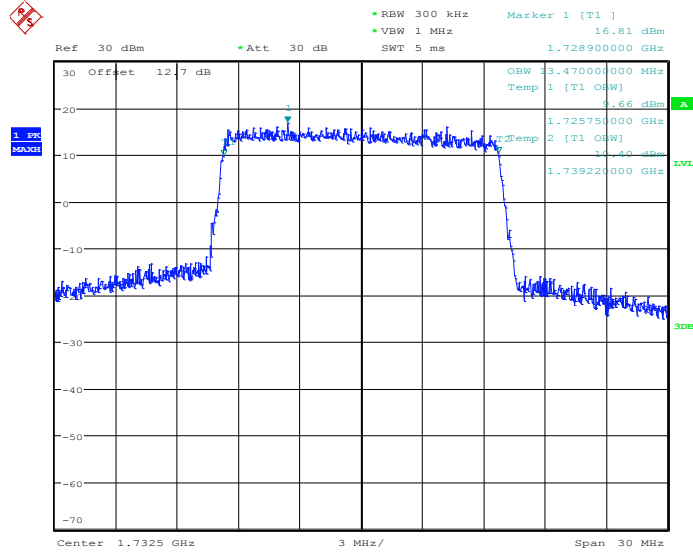

Date: 3.JUN.2014 23:09:07

26dB Bandwidth Plot on Channel 20175

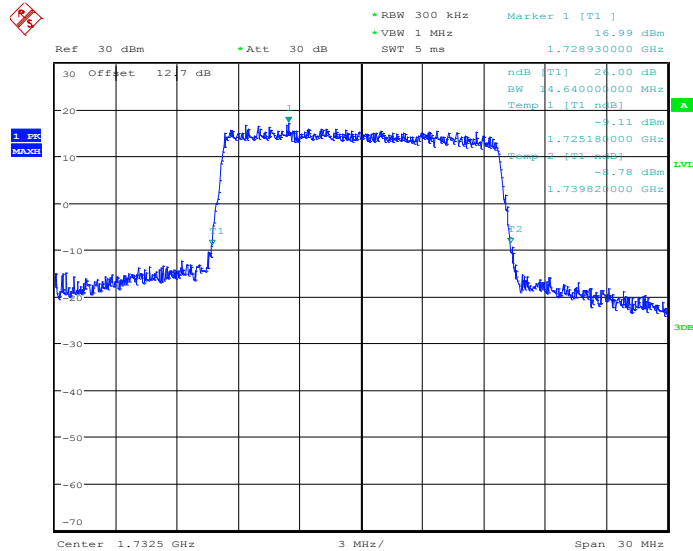

Date: 3.JUN.2014 23:09:44



99% Occupied Bandwidth Plot on Channel 20325

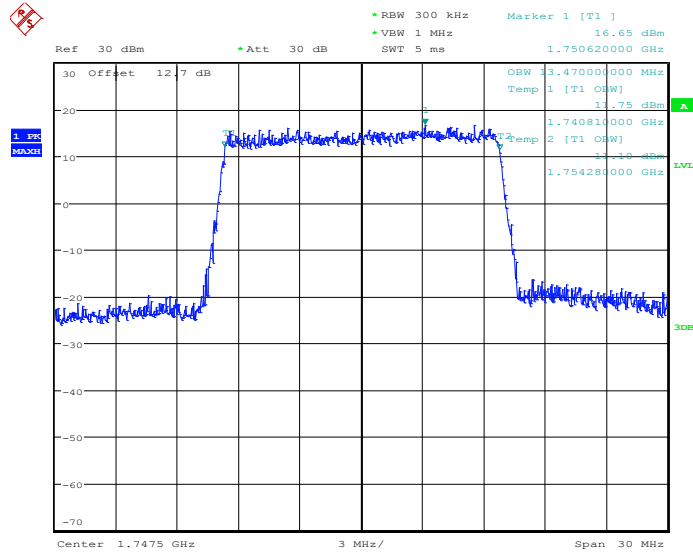

Date: 3.JUN.2014 23:12:19

26dB Bandwidth Plot on Channel 20325

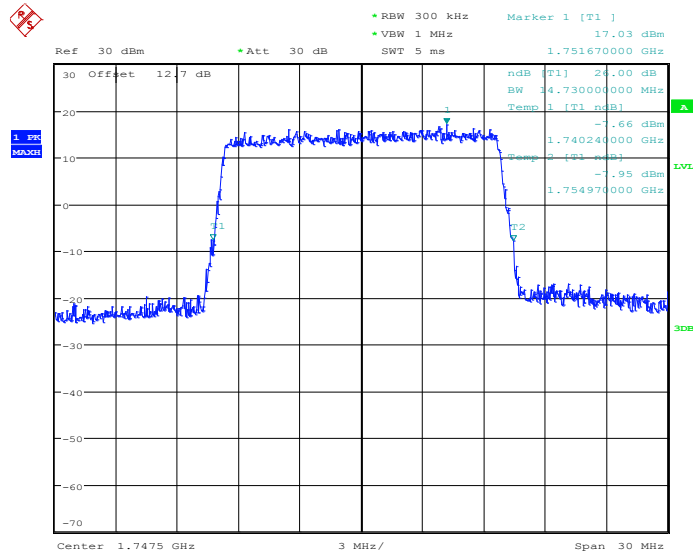

Date: 3.JUN.2014 23:12:56



Band :	LTE Band 4	BW / Mod. :	20MHz / QPSK
---------------	------------	--------------------	--------------

99% Occupied Bandwidth Plot on Channel 20050

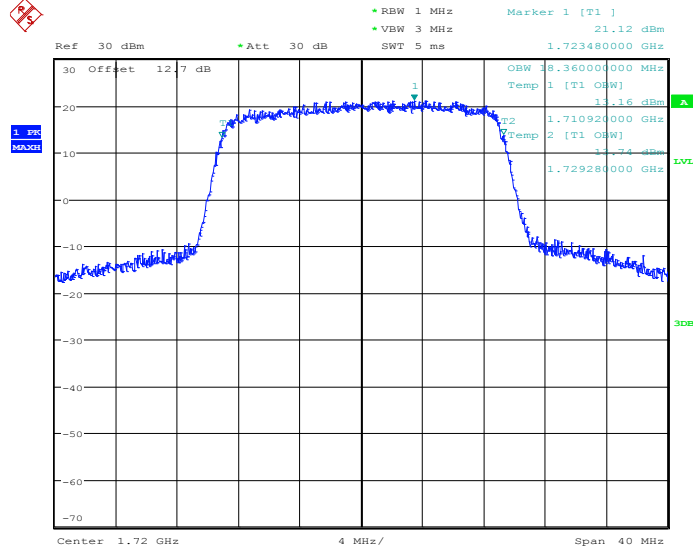

Date: 3.JUN.2014 23:18:31

26dB Bandwidth Plot on Channel 20050

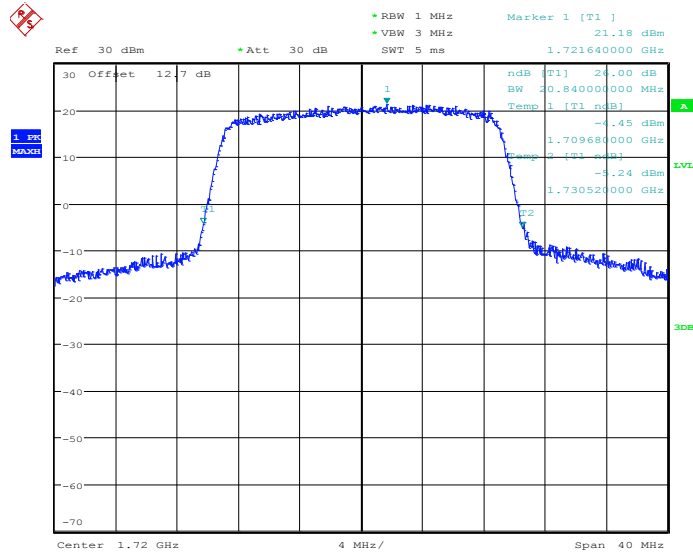

Date: 3.JUN.2014 23:19:06



99% Occupied Bandwidth Plot on Channel 20175

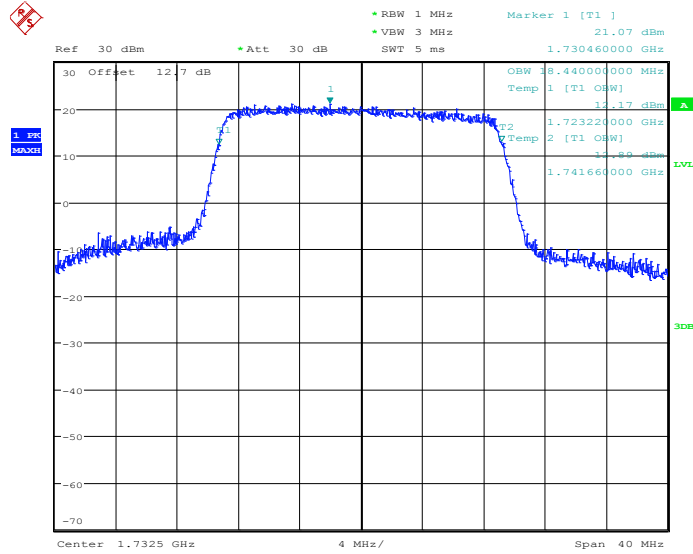

Date: 3.JUN.2014 23:24:54

26dB Bandwidth Plot on Channel 20175

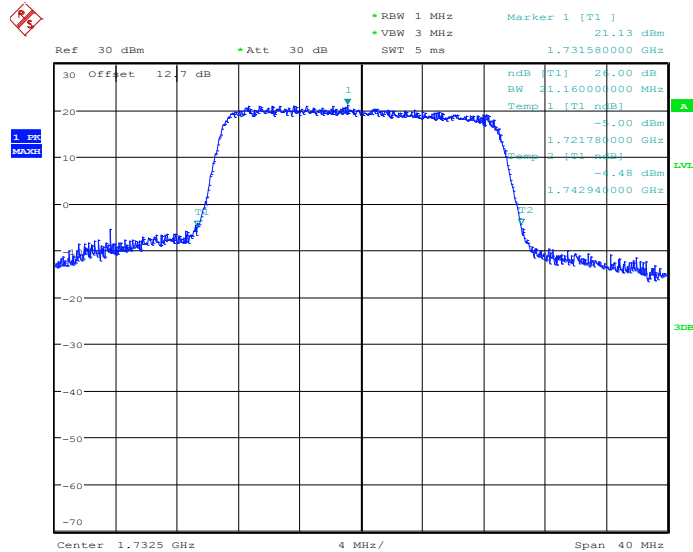

Date: 3.JUN.2014 23:25:29



99% Occupied Bandwidth Plot on Channel 20300

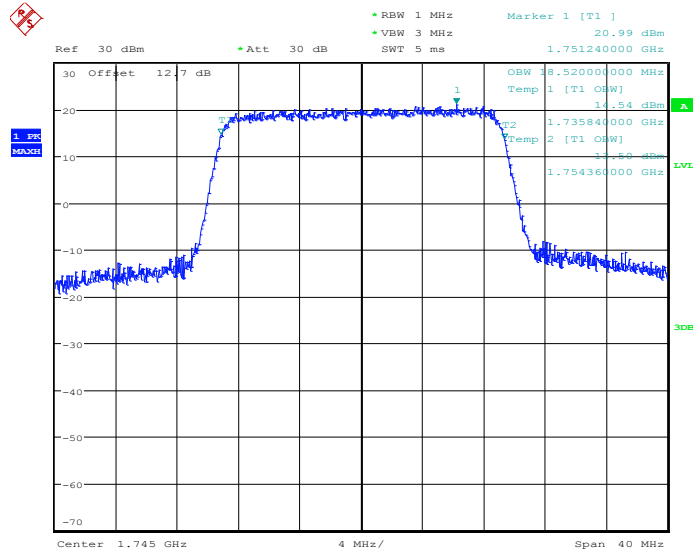

Date: 3.JUN.2014 23:28:06

26dB Bandwidth Plot on Channel 20300

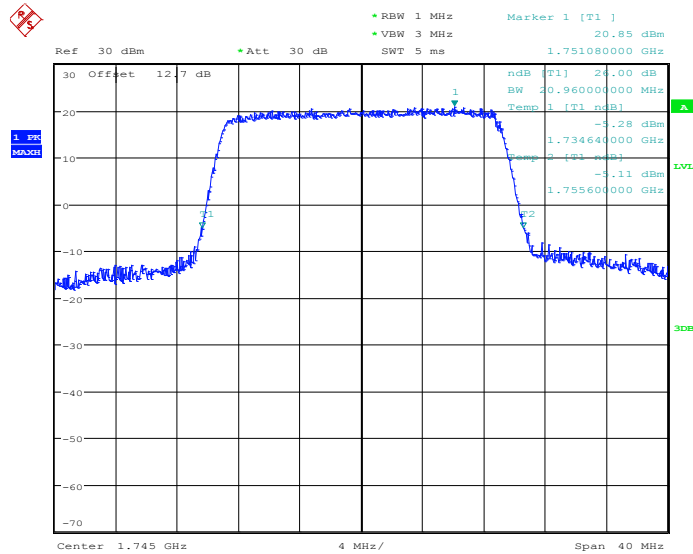

Date: 3.JUN.2014 23:28:42



Band :	LTE Band 4	BW / Mod. :	20MHz / 16QAM
---------------	------------	--------------------	---------------

99% Occupied Bandwidth Plot on Channel 20050

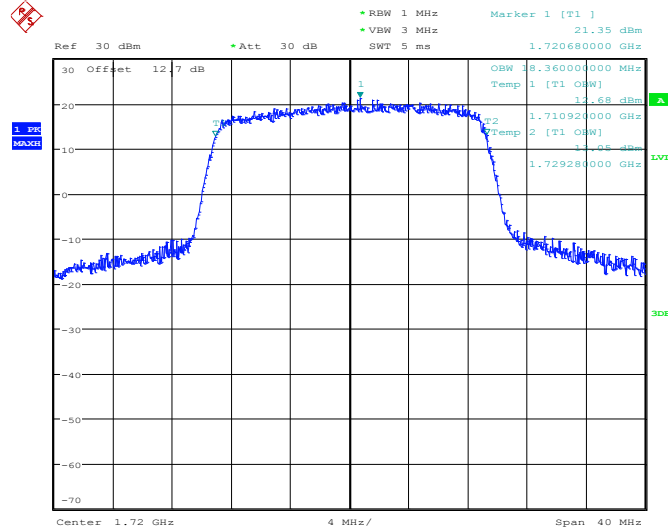

Date: 3.JUN.2014 23:18:47

26dB Bandwidth Plot on Channel 20050

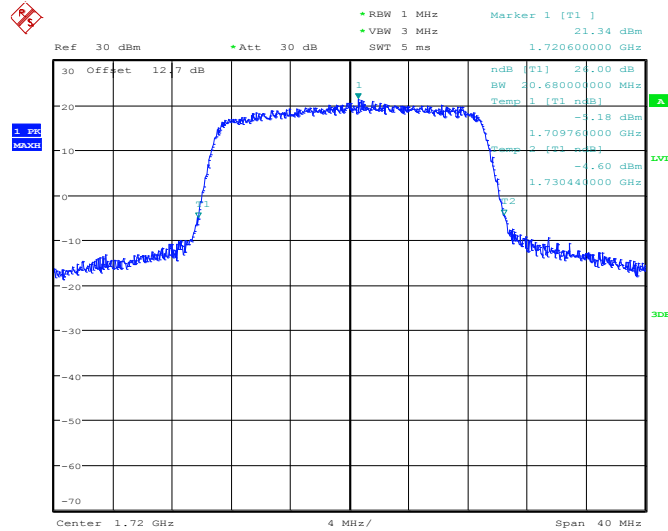

Date: 3.JUN.2014 23:19:24



99% Occupied Bandwidth Plot on Channel 20175

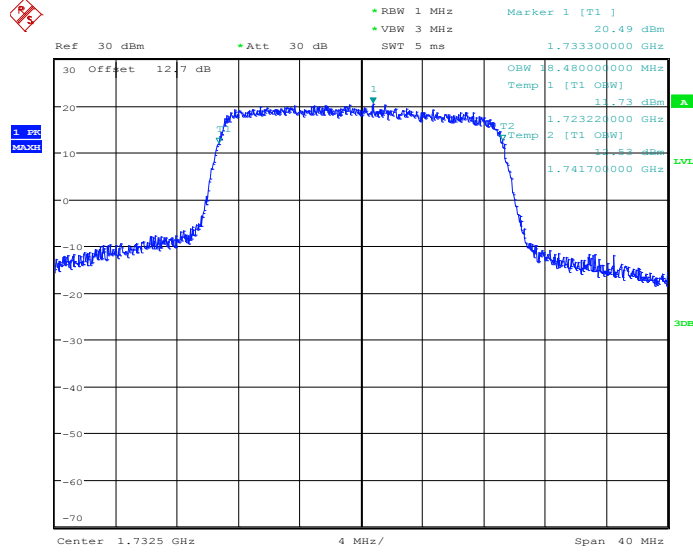

Date: 3.JUN.2014 23:25:11

26dB Bandwidth Plot on Channel 20175

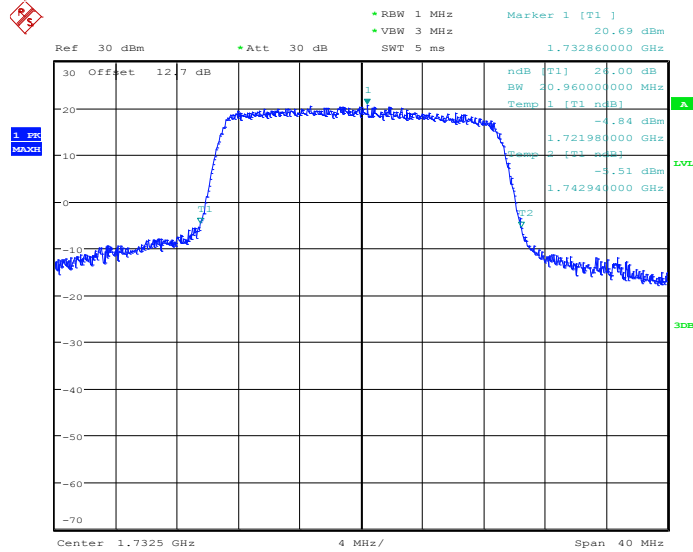

Date: 3.JUN.2014 23:25:48



99% Occupied Bandwidth Plot on Channel 20300

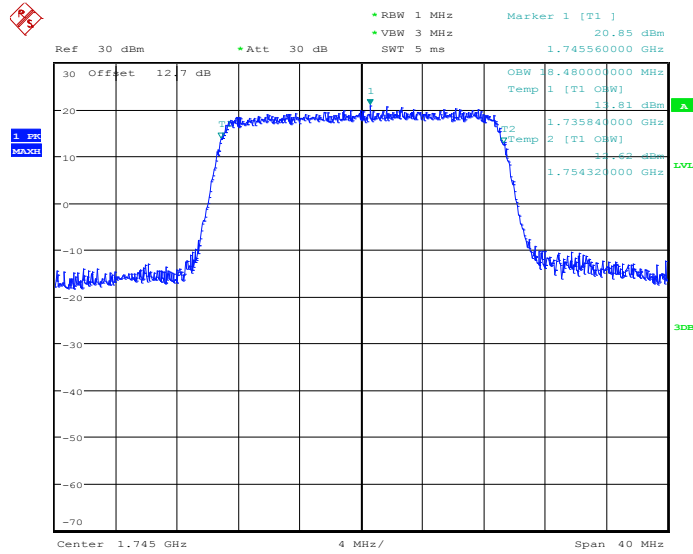

Date: 3.JUN.2014 23:28:23

26dB Bandwidth Plot on Channel 20300

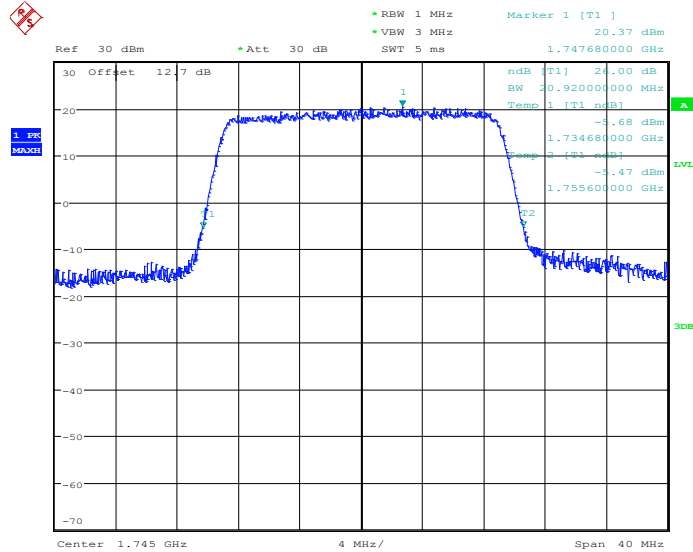

Date: 3.JUN.2014 23:29:00



Band :	LTE Band 7	BW / Mod. :	5MHz / QPSK
---------------	------------	--------------------	-------------

99% Occupied Bandwidth Plot on Channel 20775

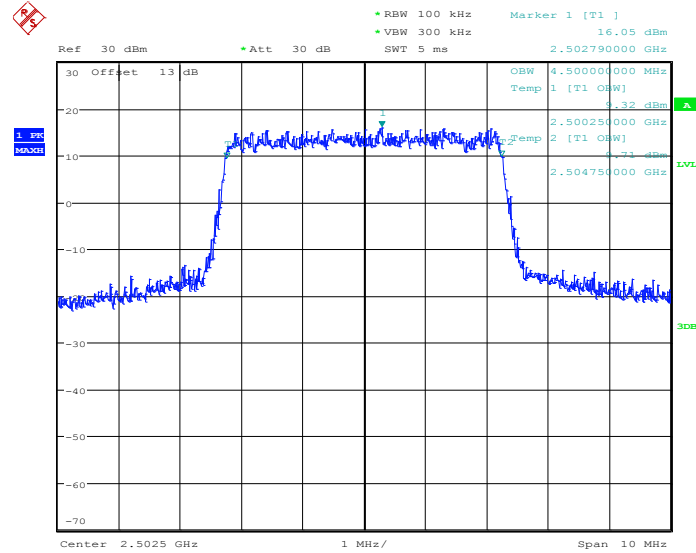

Date: 3.JUN.2014 23:47:47

26dB Bandwidth Plot on Channel 20775

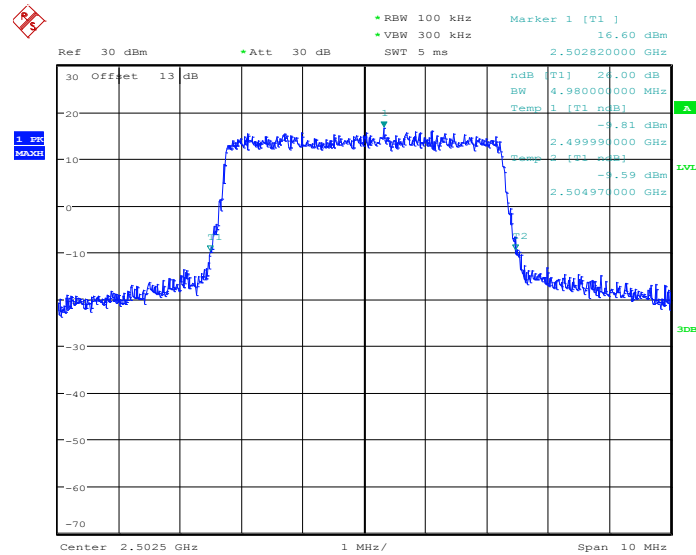

Date: 3.JUN.2014 23:48:22



99% Occupied Bandwidth Plot on Channel 21100

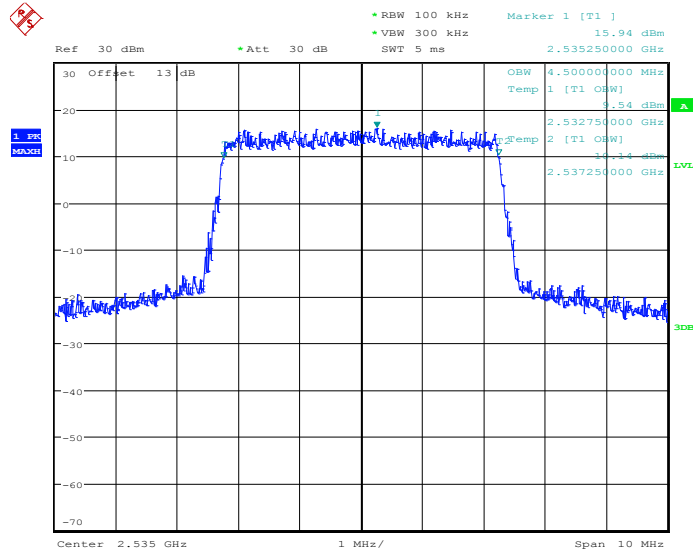

Date: 3.JUN.2014 23:54:16

26dB Bandwidth Plot on Channel 21100

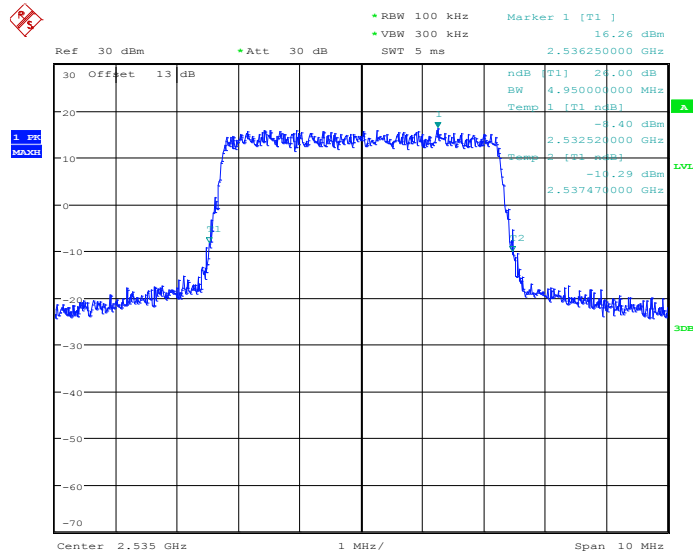

Date: 3.JUN.2014 23:54:51



99% Occupied Bandwidth Plot on Channel 21425

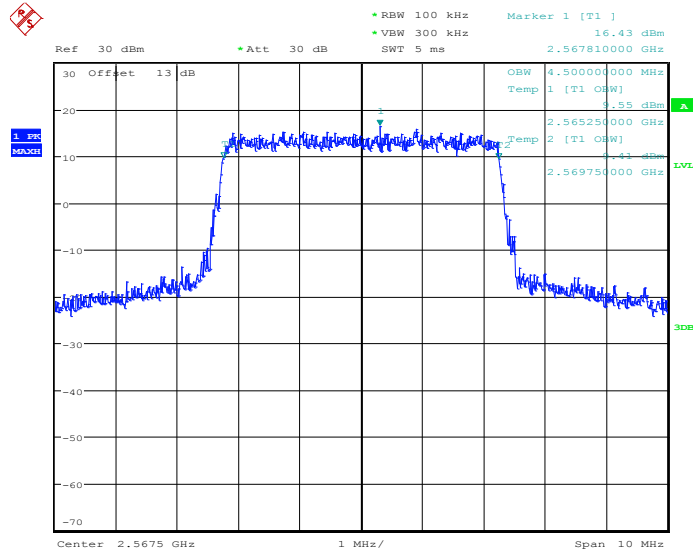

Date: 3.JUN.2014 23:57:32

26dB Bandwidth Plot on Channel 21425

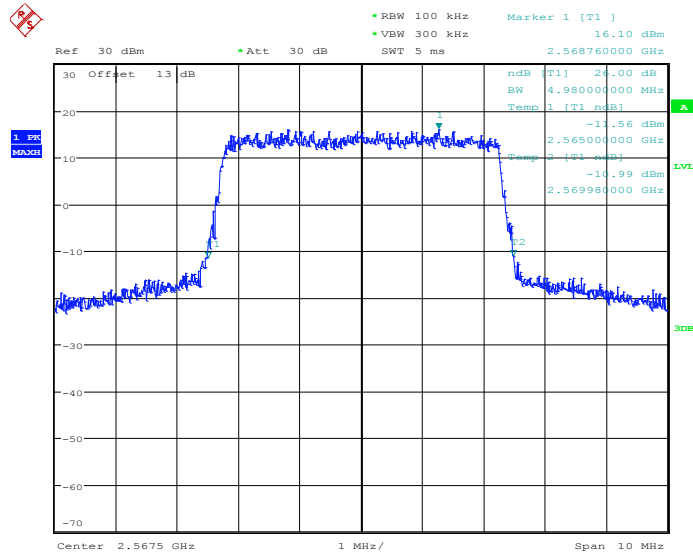

Date: 3.JUN.2014 23:58:07



Band :	LTE Band 7	BW / Mod. :	5MHz / 16QAM
--------	------------	-------------	--------------

99% Occupied Bandwidth Plot on Channel 20775

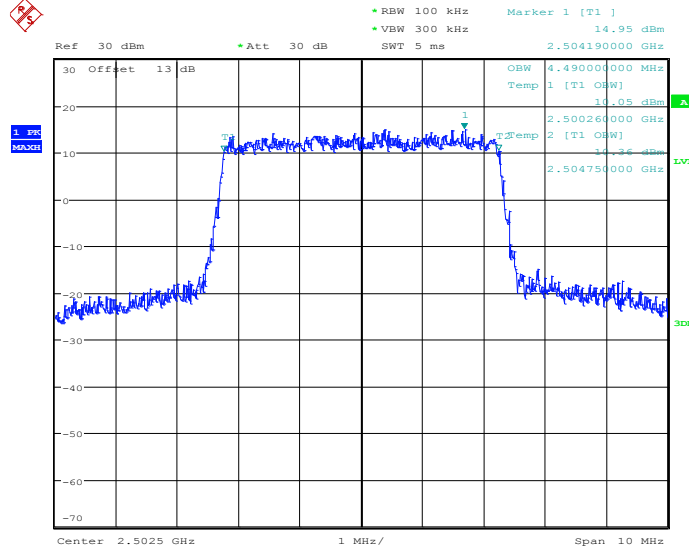

Date: 3.JUN.2014 23:48:04

26dB Bandwidth Plot on Channel 20775

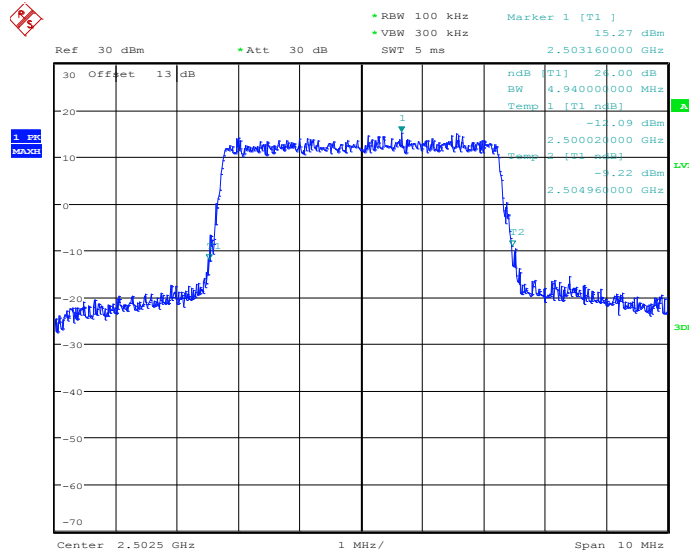

Date: 3.JUN.2014 23:48:40



99% Occupied Bandwidth Plot on Channel 21100

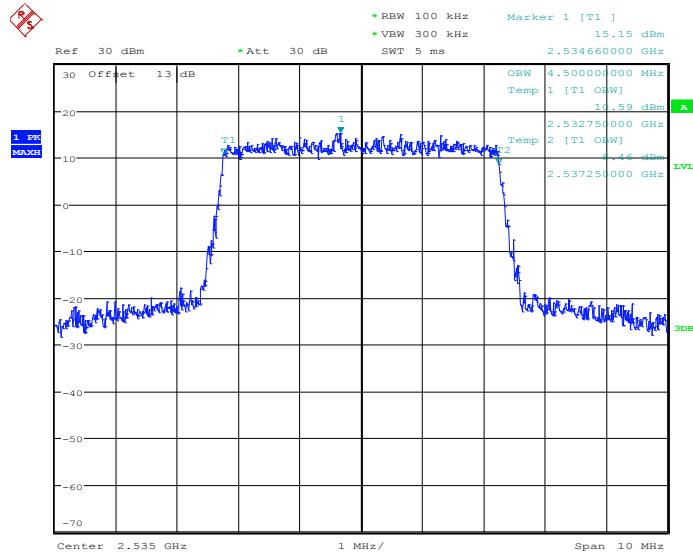

Date: 3.JUN.2014 23:54:32

26dB Bandwidth Plot on Channel 21100

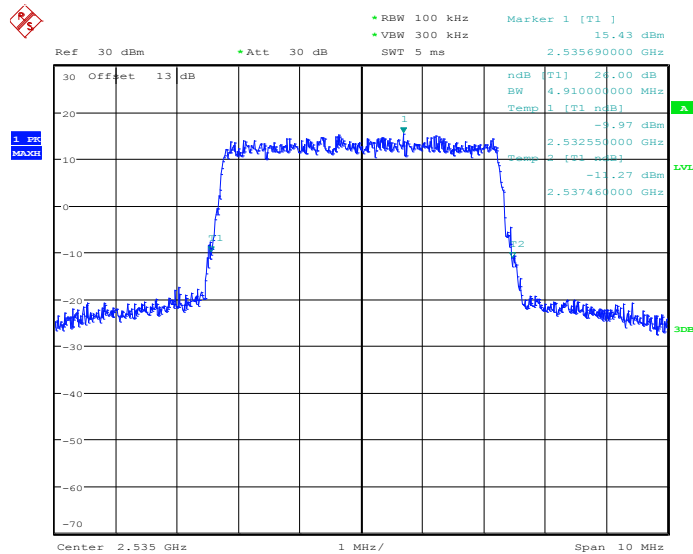

Date: 3.JUN.2014 23:55:09



99% Occupied Bandwidth Plot on Channel 21425

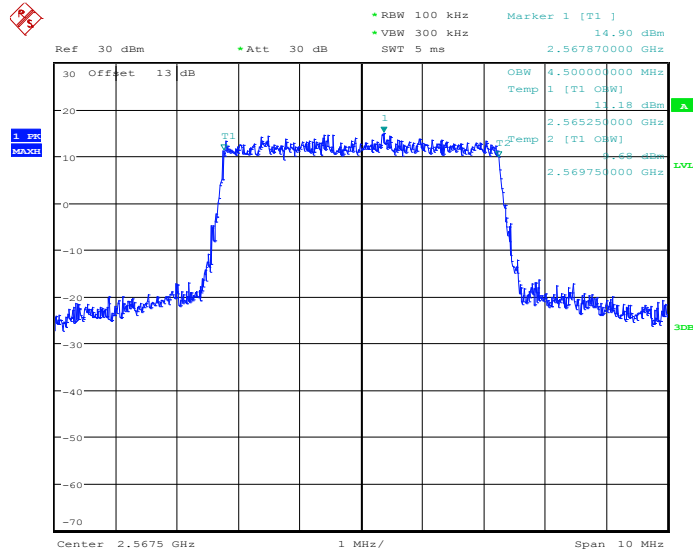

Date: 3.JUN.2014 23:57:48

26dB Bandwidth Plot on Channel 21425

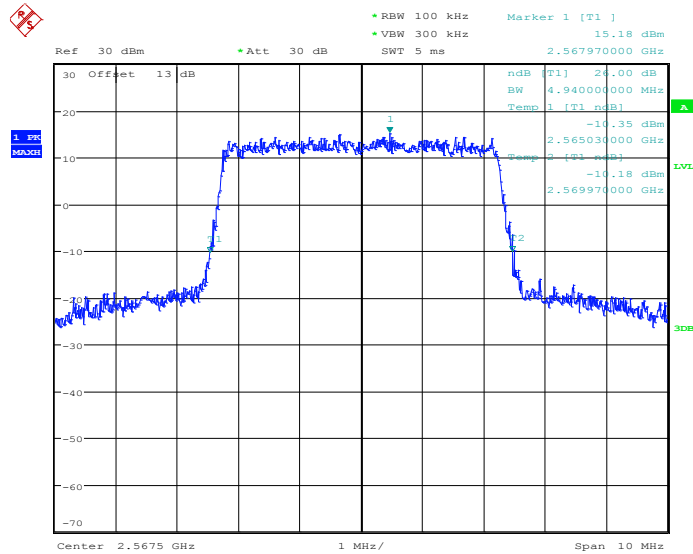

Date: 3.JUN.2014 23:58:25



Band :	LTE Band 7	BW / Mod. :	10MHz / QPSK
---------------	------------	--------------------	--------------

99% Occupied Bandwidth Plot on Channel 20800

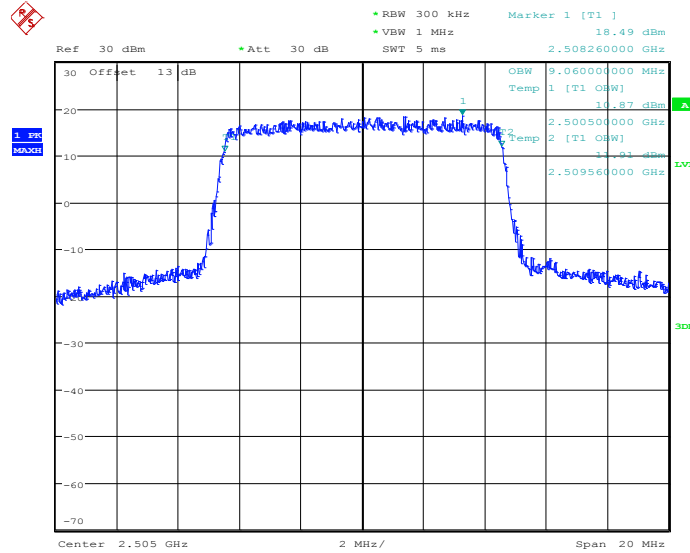

Date: 4.JUN.2014 00:04:03

26dB Bandwidth Plot on Channel 20800

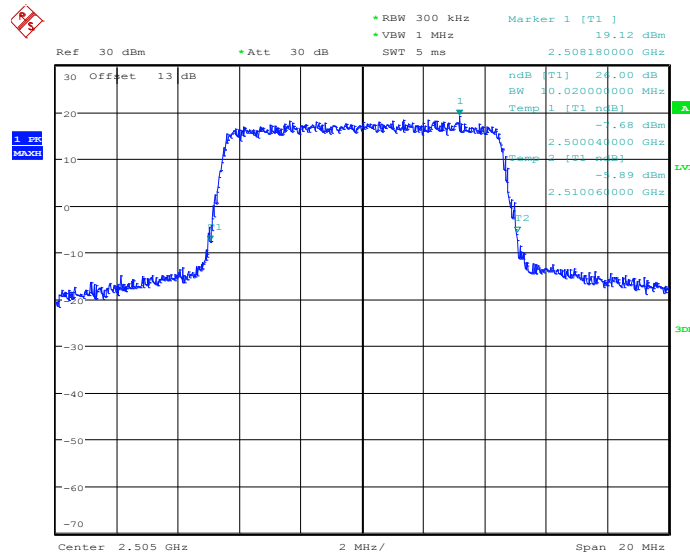

Date: 4.JUN.2014 00:04:38



99% Occupied Bandwidth Plot on Channel 21100

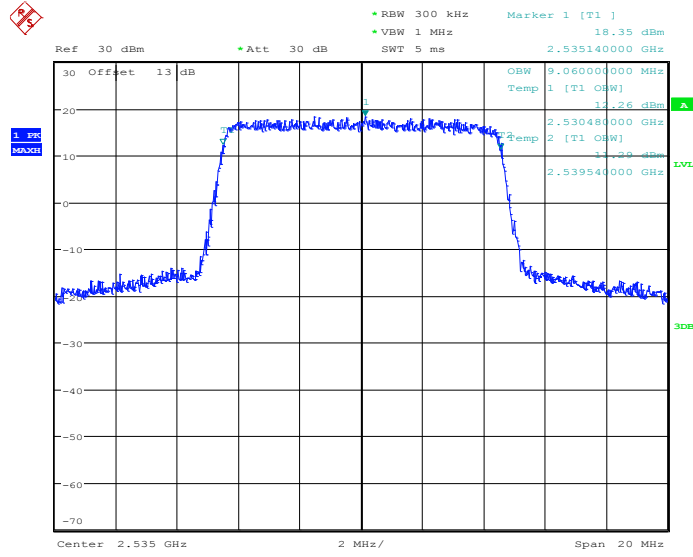

Date: 4.JUN.2014 00:10:28

26dB Bandwidth Plot on Channel 21100

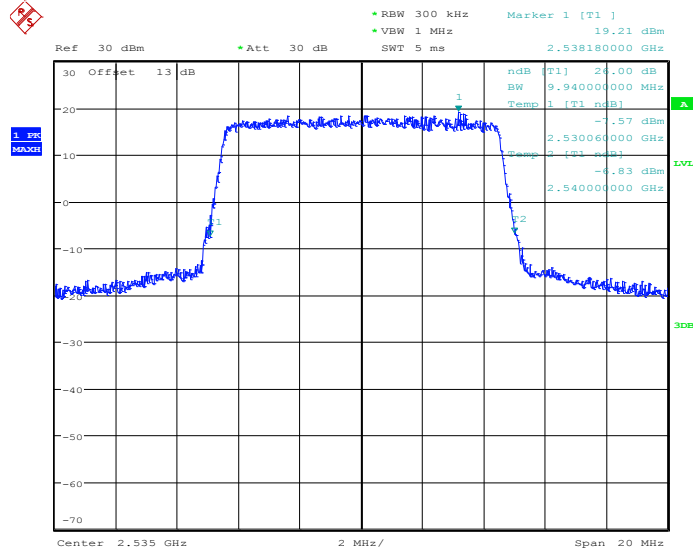

Date: 4.JUN.2014 00:11:03



99% Occupied Bandwidth Plot on Channel 21400

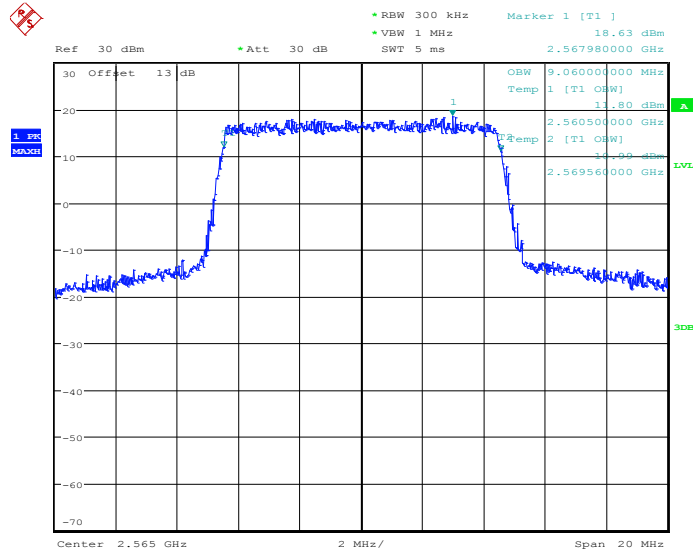

Date: 4.JUN.2014 00:13:45

26dB Bandwidth Plot on Channel 21400

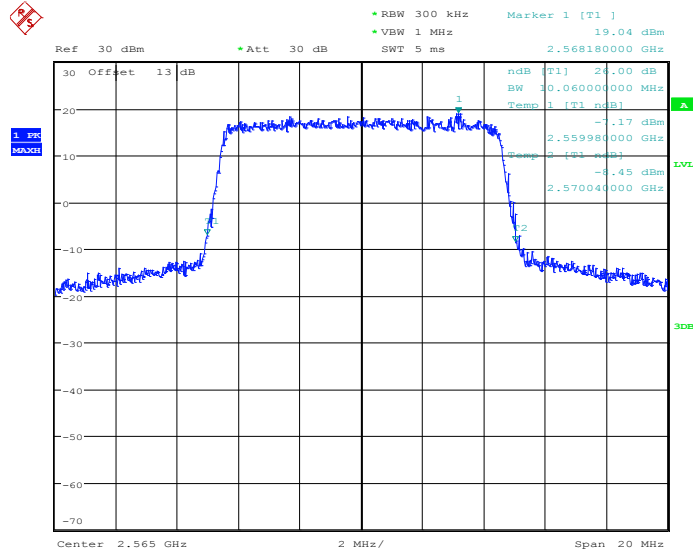

Date: 4.JUN.2014 00:14:20



Band :	LTE Band 7	BW / Mod. :	10MHz / 16QAM
---------------	------------	--------------------	---------------

99% Occupied Bandwidth Plot on Channel 20800

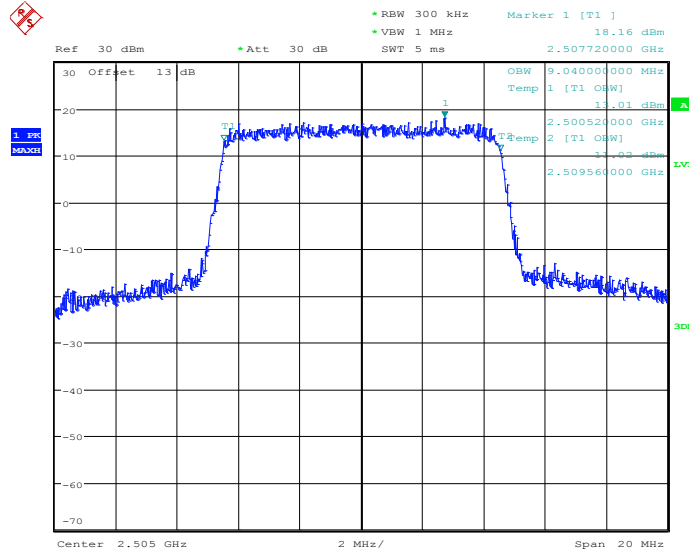

Date: 4.JUN.2014 00:04:19

26dB Bandwidth Plot on Channel 20800

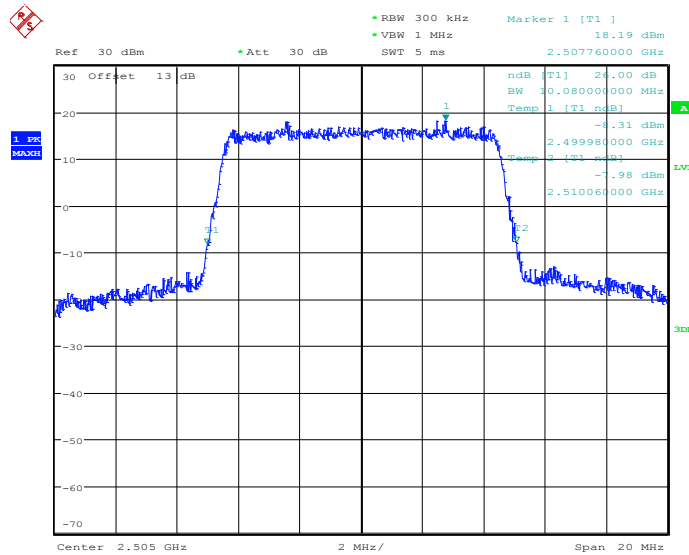

Date: 4.JUN.2014 00:04:56



99% Occupied Bandwidth Plot on Channel 21100

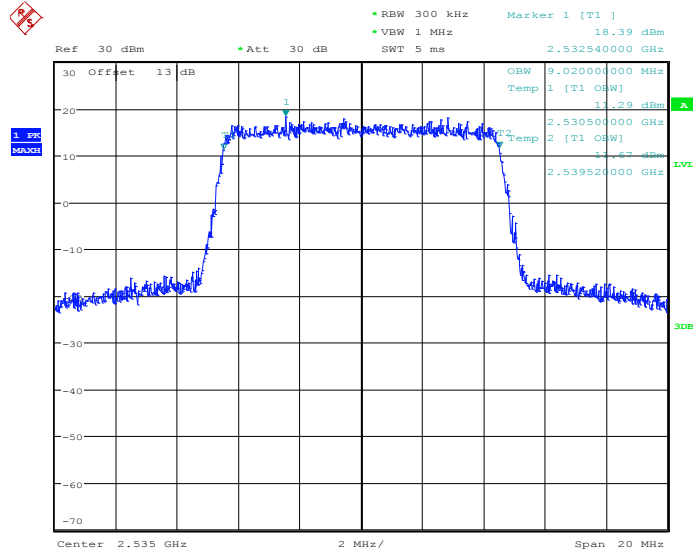

Date: 4.JUN.2014 00:10:45

26dB Bandwidth Plot on Channel 21100

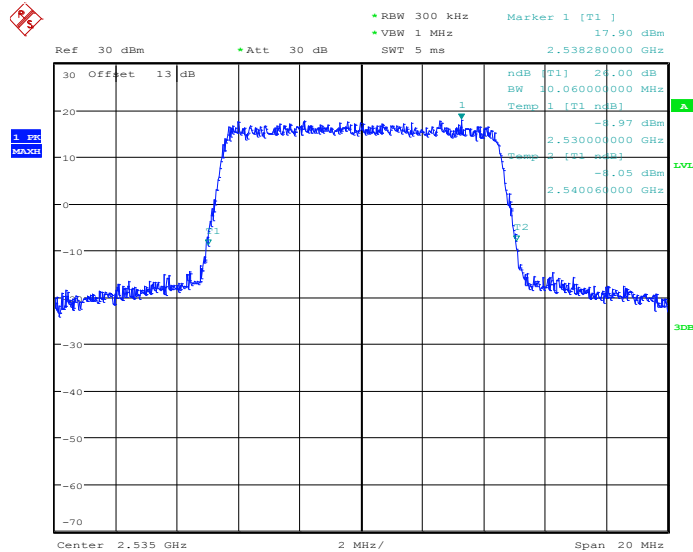

Date: 4.JUN.2014 00:11:22



99% Occupied Bandwidth Plot on Channel 21400

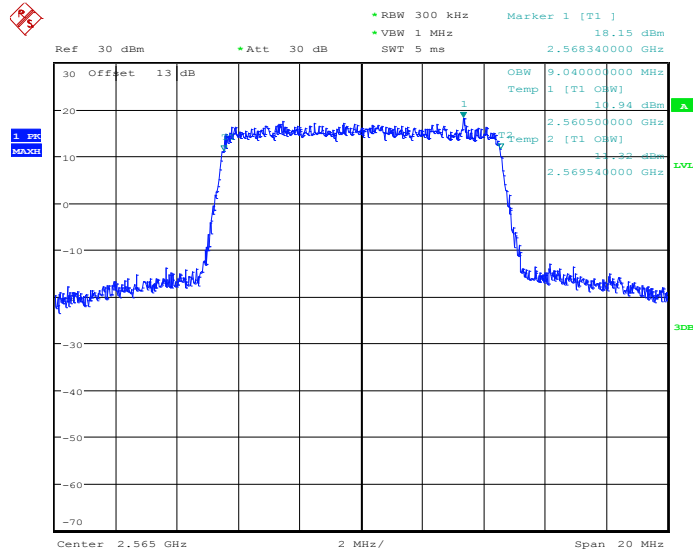

Date: 4.JUN.2014 00:14:01

26dB Bandwidth Plot on Channel 21400

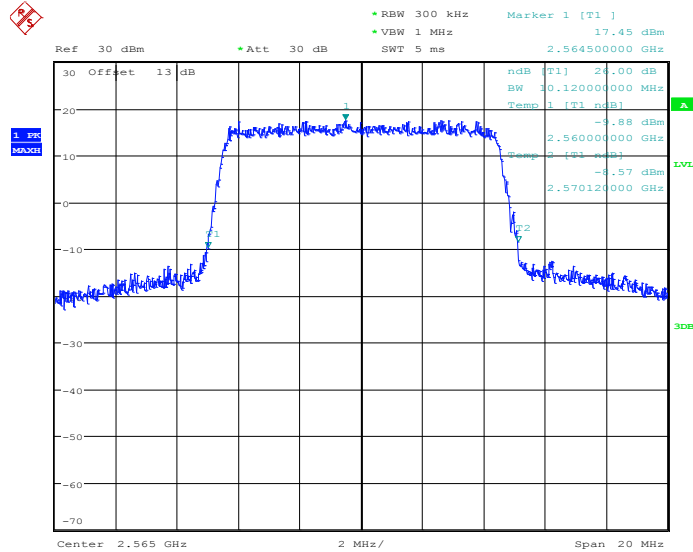

Date: 4.JUN.2014 00:14:38



Band :	LTE Band 7	BW / Mod. :	15MHz / QPSK
---------------	------------	--------------------	--------------

99% Occupied Bandwidth Plot on Channel 20825

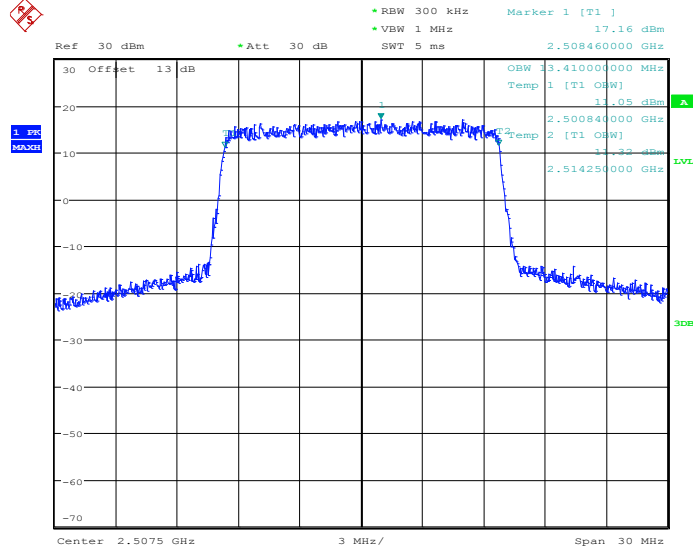

Date: 4.JUN.2014 00:20:15

26dB Bandwidth Plot on Channel 20825

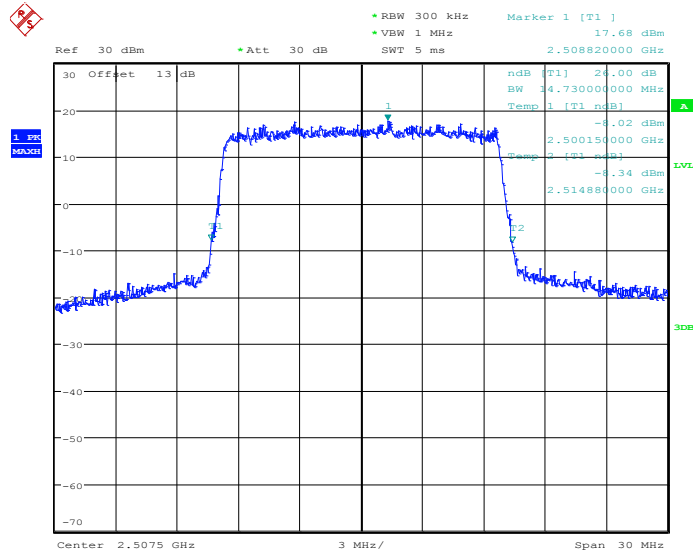

Date: 4.JUN.2014 00:20:51



99% Occupied Bandwidth Plot on Channel 21100

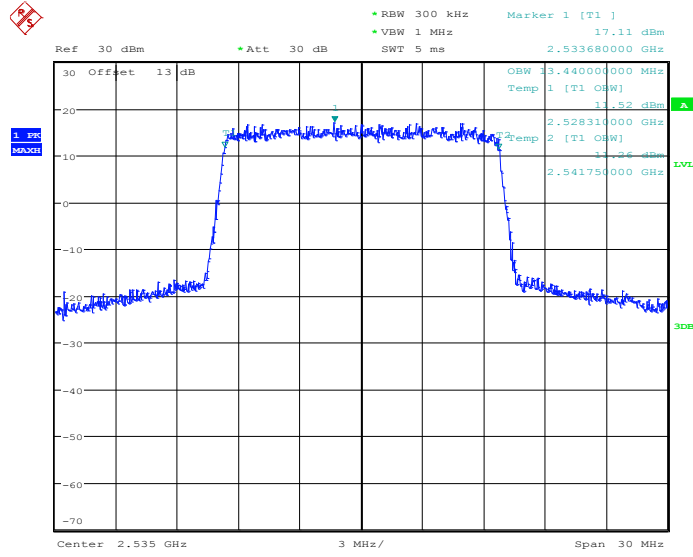

Date: 4.JUN.2014 00:26:42

26dB Bandwidth Plot on Channel 21100

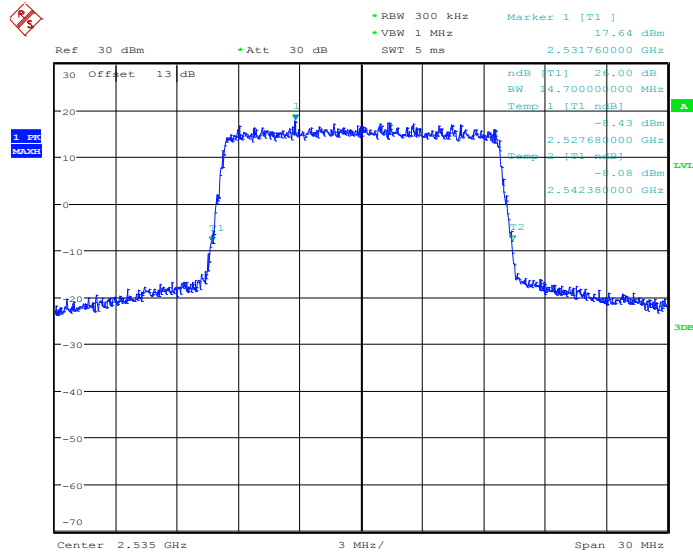

Date: 4.JUN.2014 00:27:17



99% Occupied Bandwidth Plot on Channel 21375

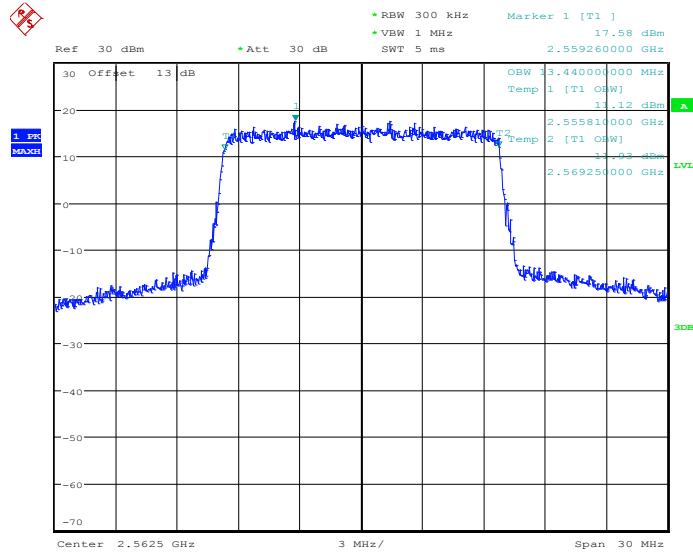

Date: 4.JUN.2014 00:29:58

26dB Bandwidth Plot on Channel 21375

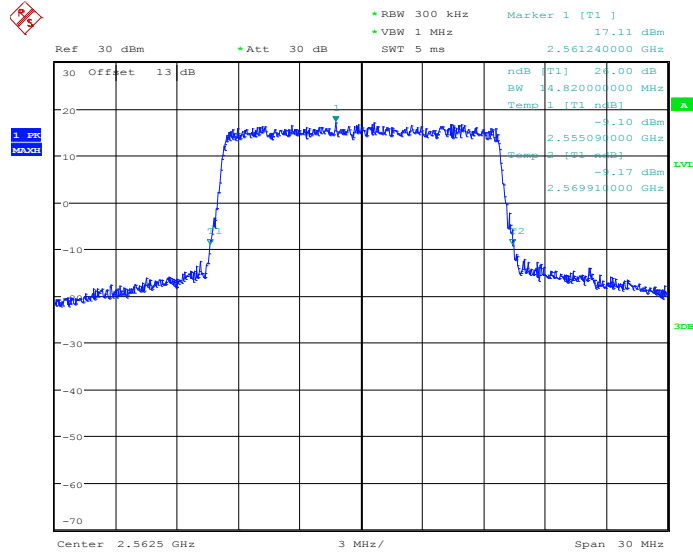

Date: 4.JUN.2014 00:30:33



Band :	LTE Band 7	BW / Mod. :	15MHz / 16QAM
--------	------------	-------------	---------------

99% Occupied Bandwidth Plot on Channel 20825

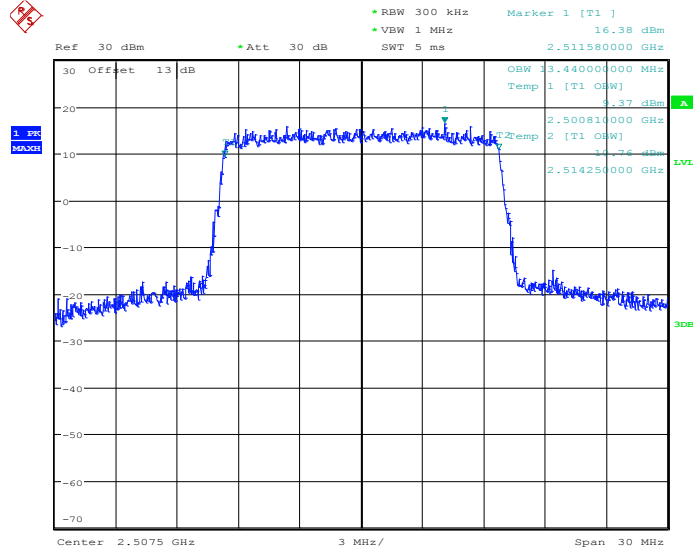

Date: 4.JUN.2014 00:20:32

26dB Bandwidth Plot on Channel 20825

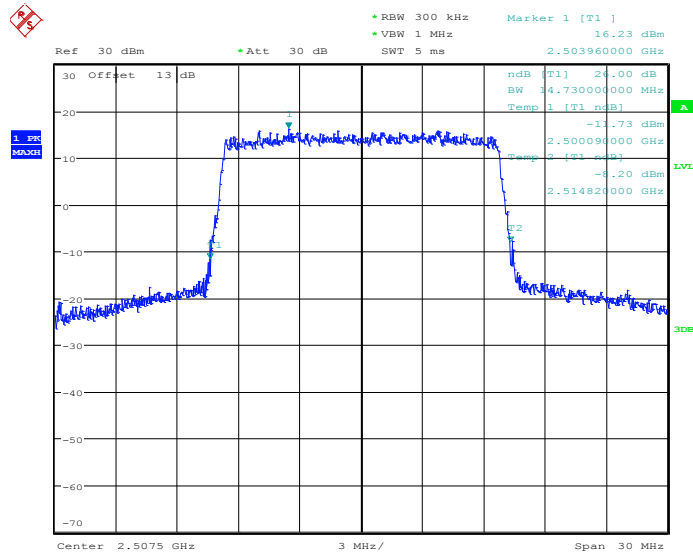

Date: 4.JUN.2014 00:21:09



99% Occupied Bandwidth Plot on Channel 21100

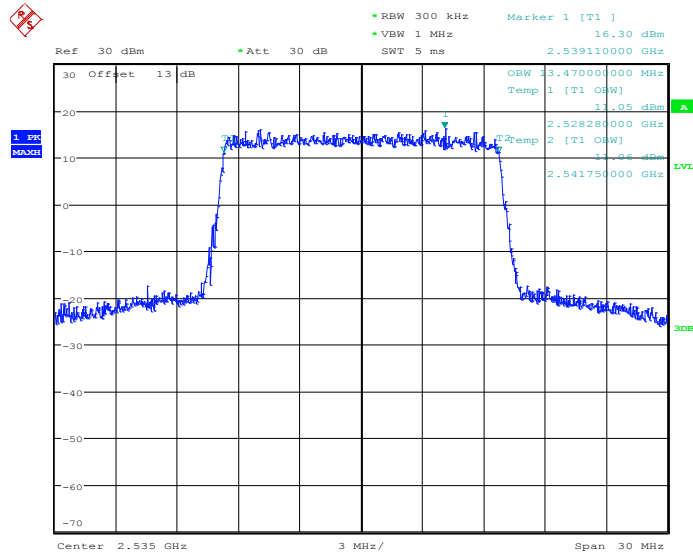

Date: 4.JUN.2014 00:26:58

26dB Bandwidth Plot on Channel 21100

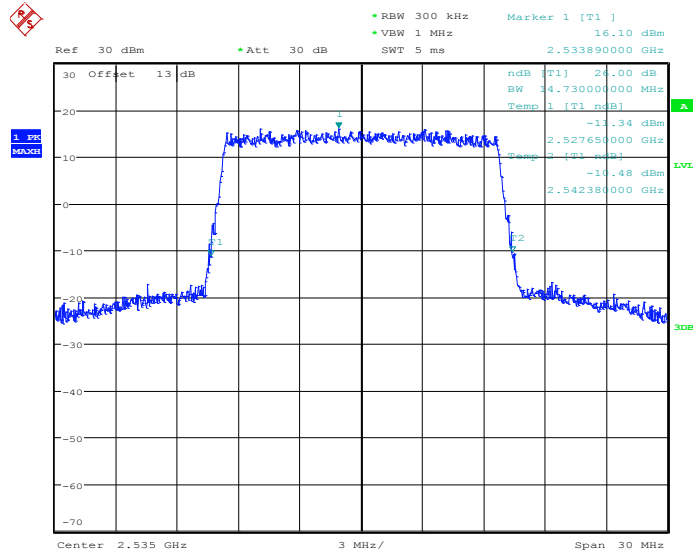

Date: 4.JUN.2014 00:27:35



99% Occupied Bandwidth Plot on Channel 21375

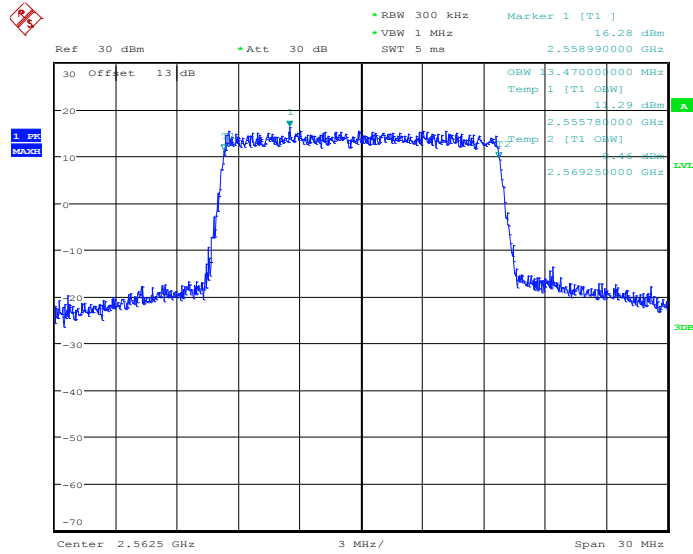

Date: 4.JUN.2014 00:30:15

26dB Bandwidth Plot on Channel 21375

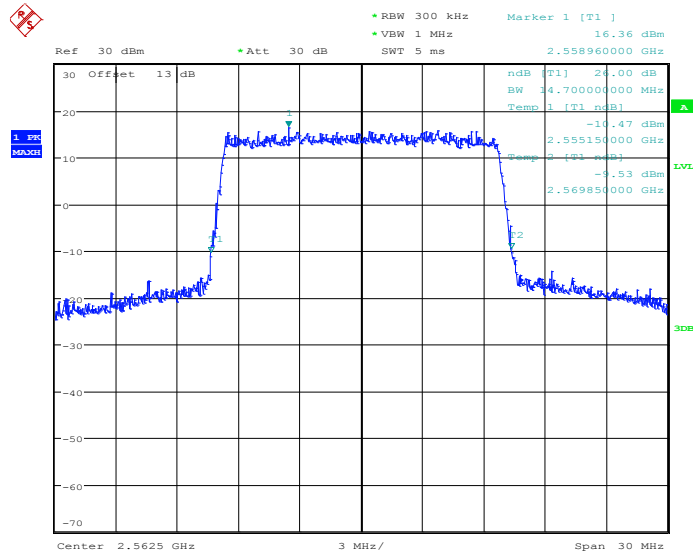

Date: 4.JUN.2014 00:30:52



Band :	LTE Band 7	BW / Mod. :	20MHz / QPSK
---------------	------------	--------------------	--------------

99% Occupied Bandwidth Plot on Channel 20850

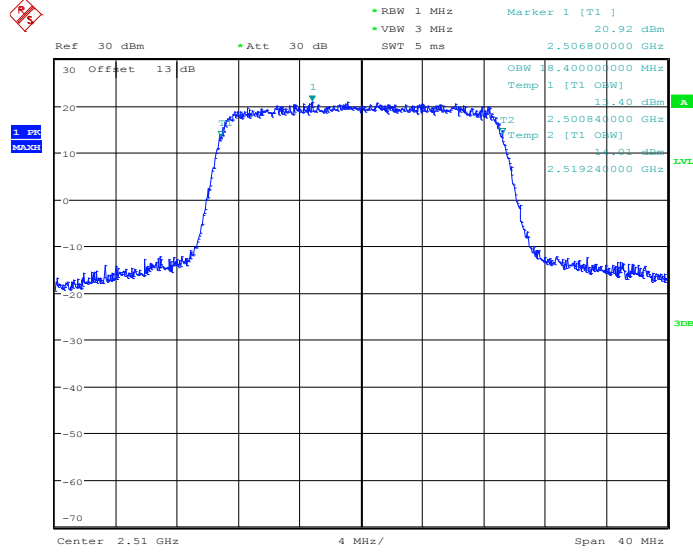

Date: 4.JUN.2014 01:03:46

26dB Bandwidth Plot on Channel 20850

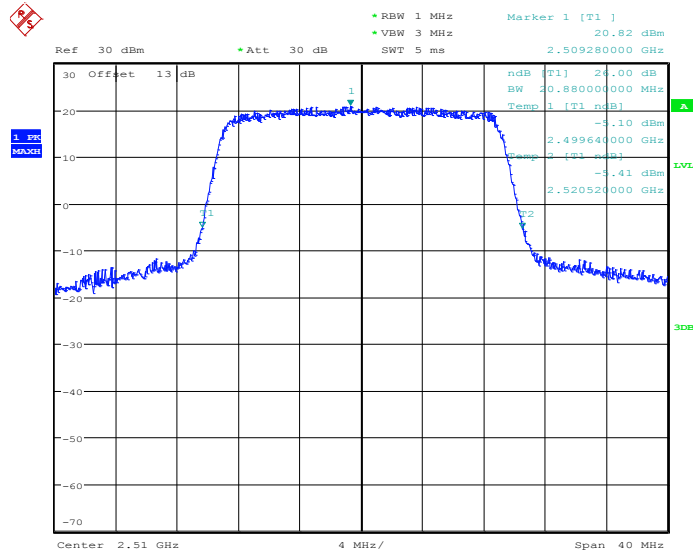

Date: 4.JUN.2014 01:04:21



99% Occupied Bandwidth Plot on Channel 21100

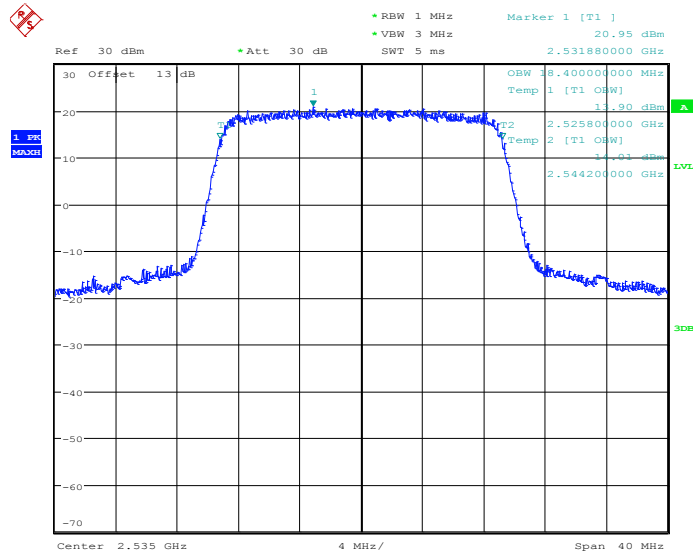

Date: 4.JUN.2014 01:10:15

26dB Bandwidth Plot on Channel 21100

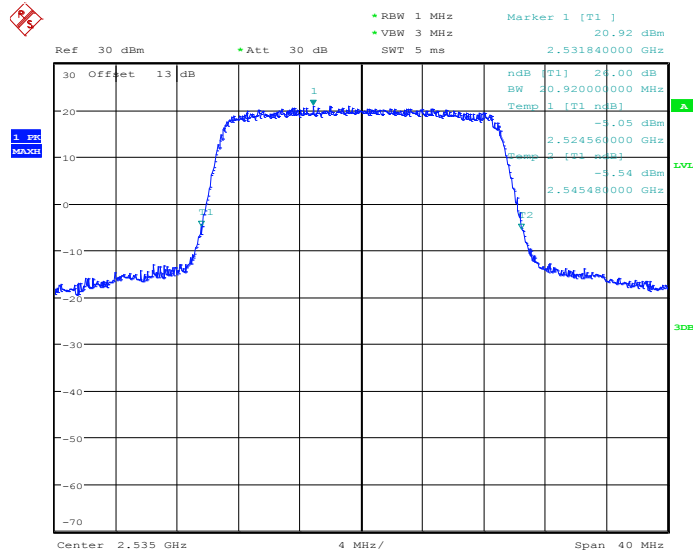

Date: 4.JUN.2014 01:10:50



99% Occupied Bandwidth Plot on Channel 21350

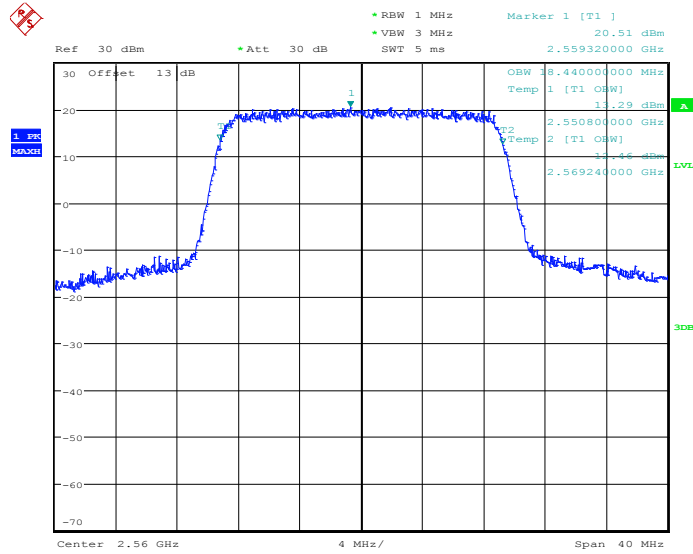

Date: 4.JUN.2014 01:13:33

26dB Bandwidth Plot on Channel 21350

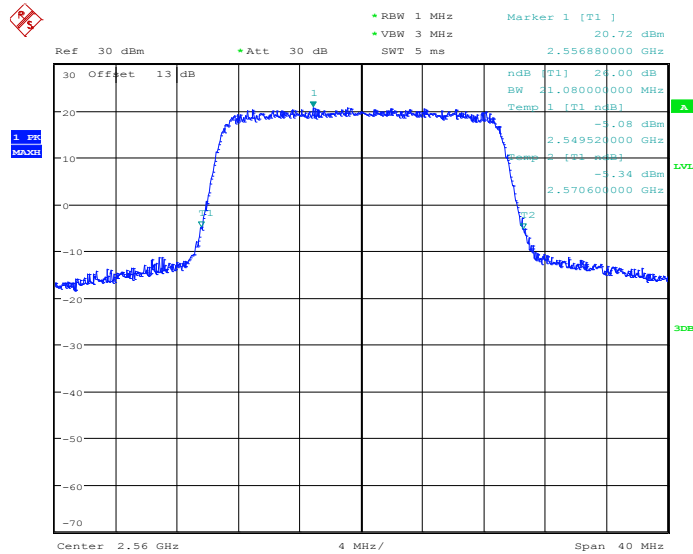

Date: 4.JUN.2014 01:14:08



Band :	LTE Band 7	BW / Mod. :	20MHz / 16QAM
---------------	------------	--------------------	---------------

99% Occupied Bandwidth Plot on Channel 20850

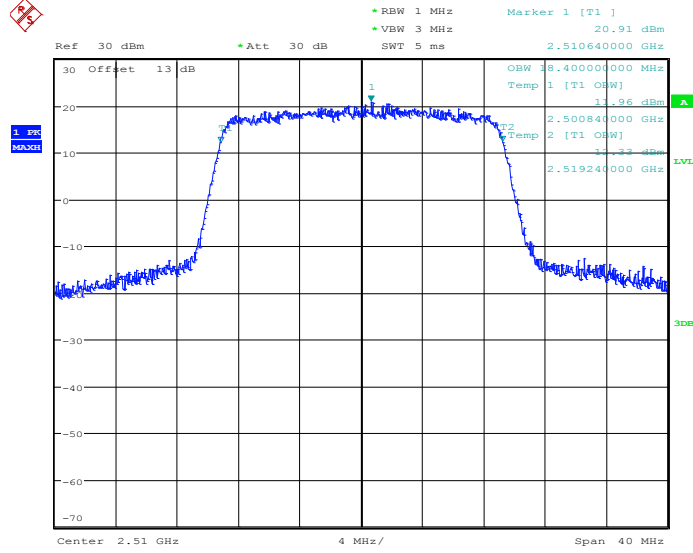

Date: 4.JUN.2014 01:04:02

26dB Bandwidth Plot on Channel 20850

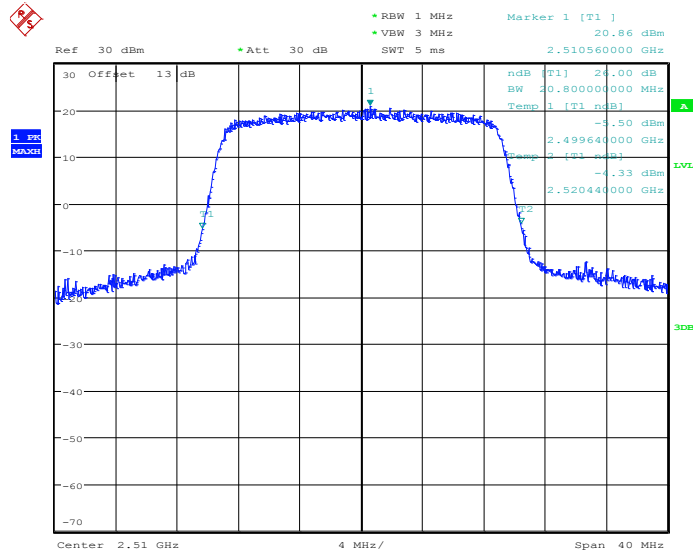

Date: 4.JUN.2014 01:04:39



99% Occupied Bandwidth Plot on Channel 21100

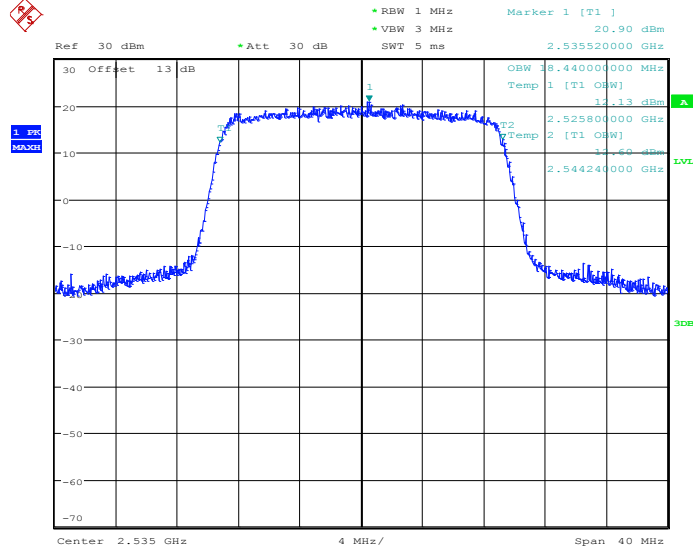

Date: 4.JUN.2014 01:10:31

26dB Bandwidth Plot on Channel 21100

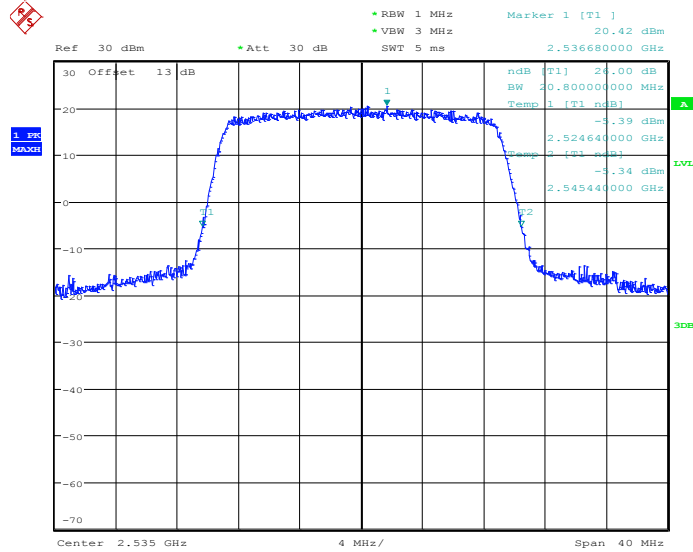

Date: 4.JUN.2014 01:11:09



99% Occupied Bandwidth Plot on Channel 21350

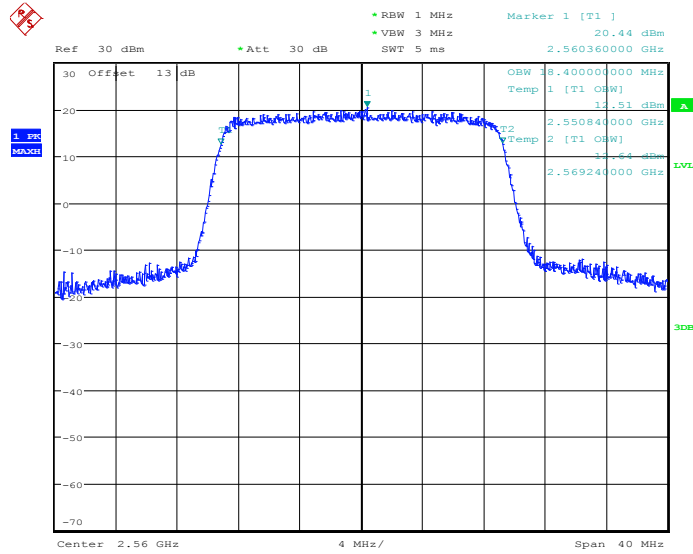

Date: 4.JUN.2014 01:13:49

26dB Bandwidth Plot on Channel 21350

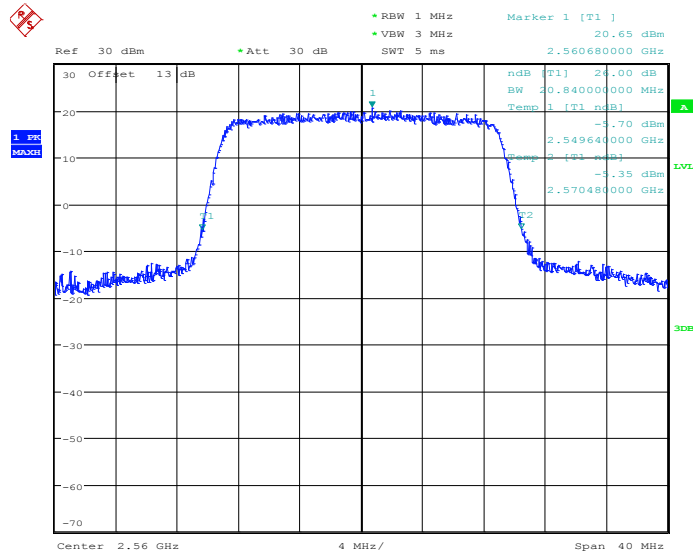

Date: 4.JUN.2014 01:14:27



3.5 Conducted Band Edge Measurement

3.5.1 Description of Conducted Band Edge Measurement

27.53(h) and RSS – 139

For operations in the 1710 – 1755 MHz band, the FCC limit is $43 + 10\log_{10}(P[\text{Watts}])$ dB below the transmitter power P(Watts) in a 1 MHz bandwidth. However, in the 1MHz bands immediately outside and adjacent to the licensee's frequency block, a resolution bandwidth of at least one percent of the emission bandwidth of the fundamental emission of the transmitter may be employed.

27.53(m)(4) and RSS – 199

The emissions be operated in the 2496-2690 MHz band, the attenuation factor of transmitter Power (P) shall be not less than $55 + 10 \log (P)$ dB at the channel edge

3.5.2 Measuring Instruments

The measuring equipment is listed in the section 4 of this test report.

3.5.3 Test Procedures

1. The EUT was connected to spectrum analyzer and system simulator via a power divider.
2. The band edges of low and high channels for the highest RF powers were measured. Set RBW $\geq 1\%$ EBW in the 1MHz band immediately outside and adjacent to the band edge.
3. Set spectrum analyzer with RMS detector.
4. The RF fundamental frequency should be excluded against the limit line in the operating frequency band.
5. The limit line is derived from $43 + 10\log(P)$ dB below the transmitter power P(Watts)
 $= P(\text{W}) - [43 + 10\log(P)]$ (dB)
 $= [30 + 10\log(P)]$ (dBm) - $[43 + 10\log(P)]$ (dB)
 $= -13\text{dBm}$.

3.5.4 Test Setup

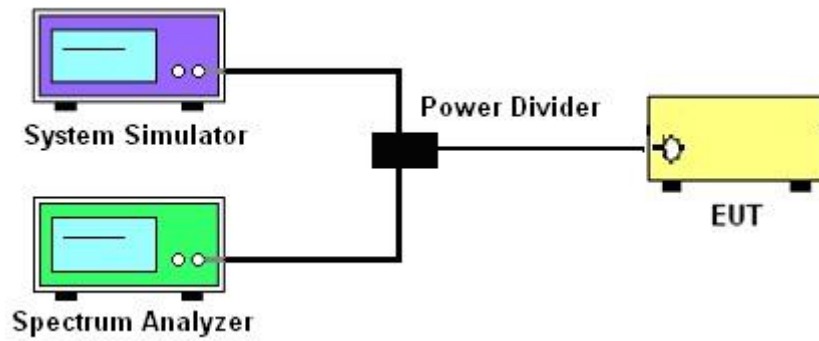



3.5.5 Test Result (Plots) of Conducted Band Edge

Band :	LTE Band 4	Band Width :	1.4MHz / QPSK
--------	------------	--------------	---------------

Lower Band Edge Plot for QPSK-RB Size 1, RB Offset 0

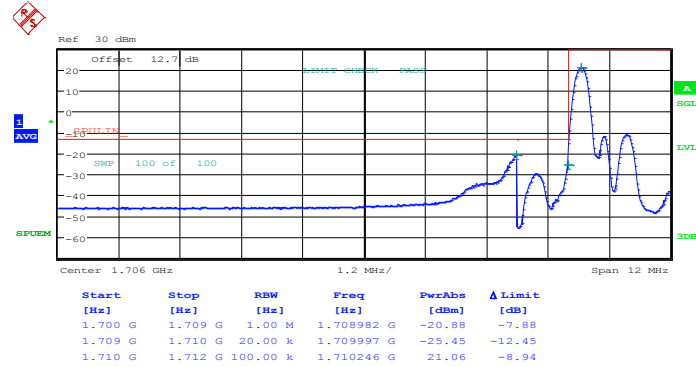

Date: 3.JUN.2014 21:32:32

Lower Band Edge Plot for QPSK-RB Size 6, RB Offset 0

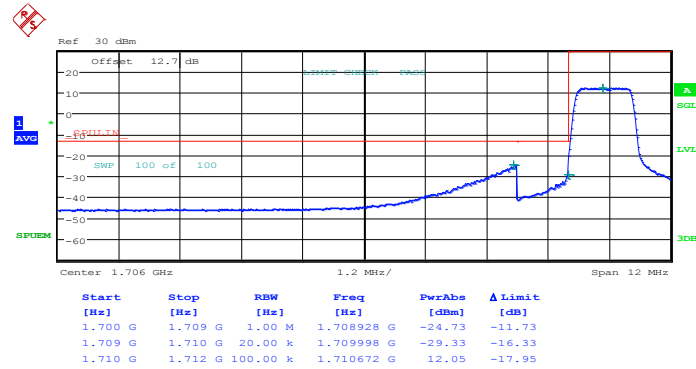

Date: 3.JUN.2014 21:34:08



Higher Band Edge Plot for QPSK-RB Size 1, RB Offset 5

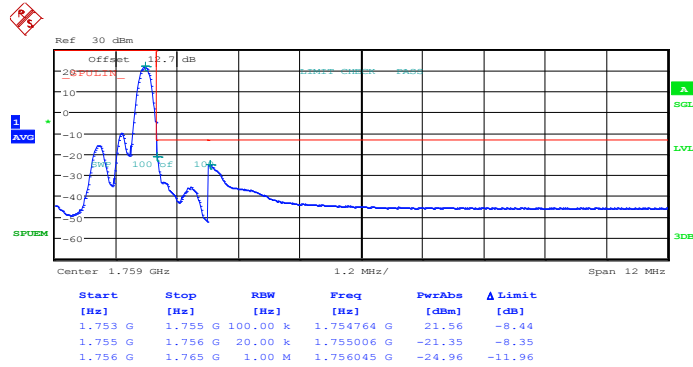

Date: 3.JUN.2014 21:42:08

Higher Band Edge Plot for QPSK-RB Size 6, RB Offset 0

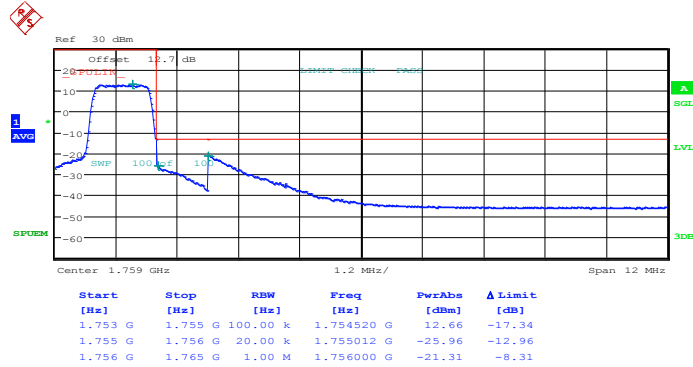

Date: 3.JUN.2014 21:43:44



Band :	LTE Band 4	Band Width :	1.4MHz / 16QAM
---------------	------------	---------------------	----------------

Lower Band Edge Plot for 16QAM -RB Size 1, RB Offset 0

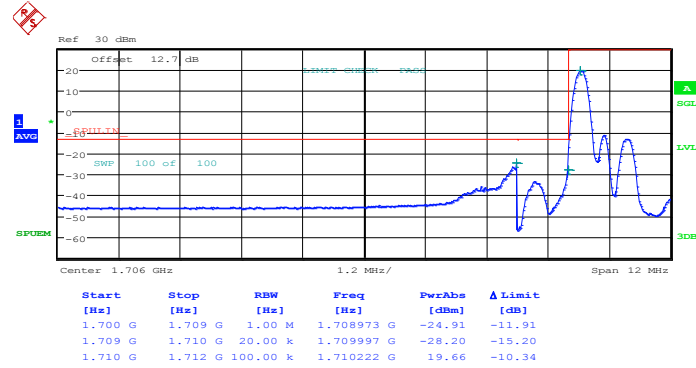

Date: 3.JUN.2014 21:33:20

Lower Band Edge Plot for 16QAM-RB Size 6, RB Offset 0

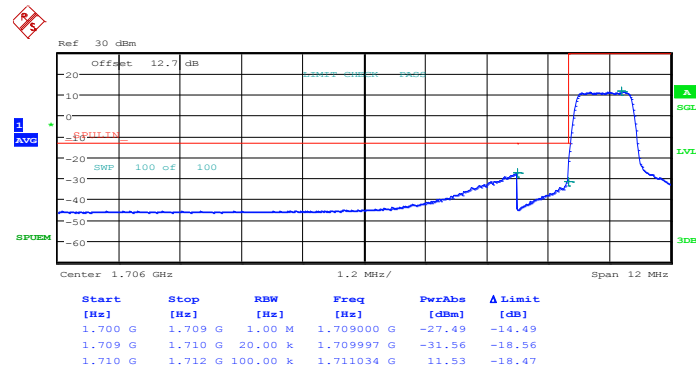

Date: 3.JUN.2014 21:34:56



Higher Band Edge Plot for 16QAM-RB Size 1, RB Offset 5

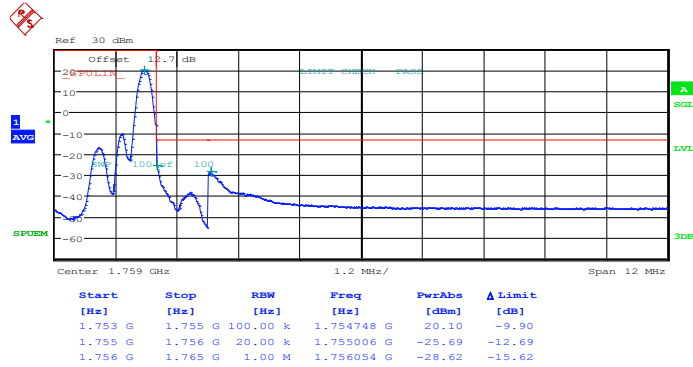

Date: 3.JUN.2014 21:42:56

Higher Band Edge Plot for 16QAM-RB Size 6, RB Offset 0

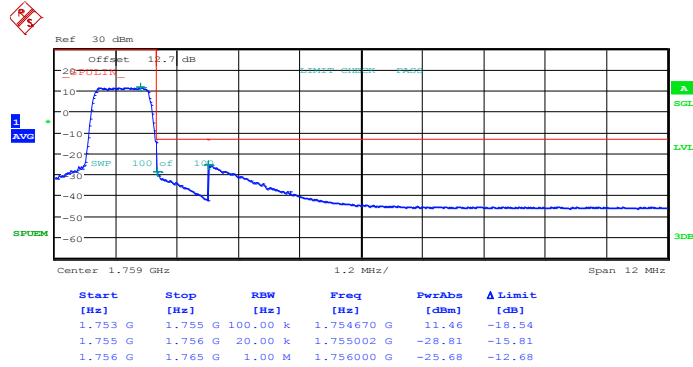

Date: 3.JUN.2014 21:44:32



Band :	LTE Band 4	Band Width :	3MHz / QPSK
---------------	------------	---------------------	-------------

Lower Band Edge Plot for QPSK-RB Size 1, RB Offset 0

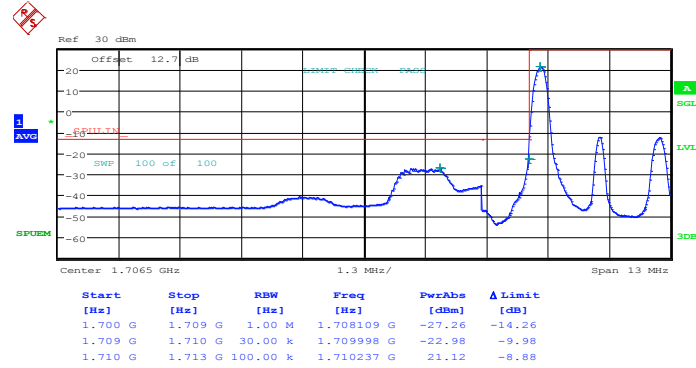

Date: 3.JUN.2014 22:15:50

Lower Band Edge Plot for QPSK-RB Size 15, RB Offset 0

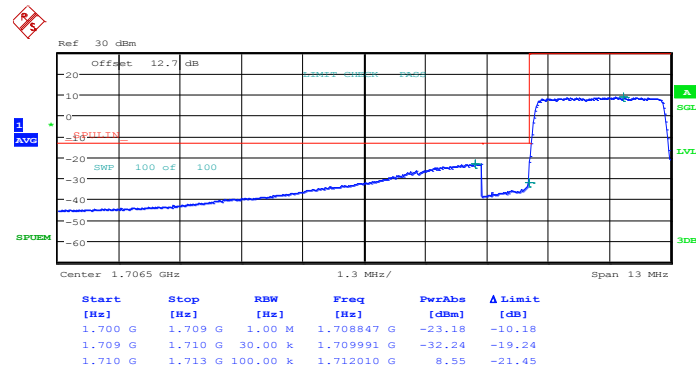

Date: 3.JUN.2014 22:17:26



Higher Band Edge Plot for QPSK-RB Size 1, RB Offset 14

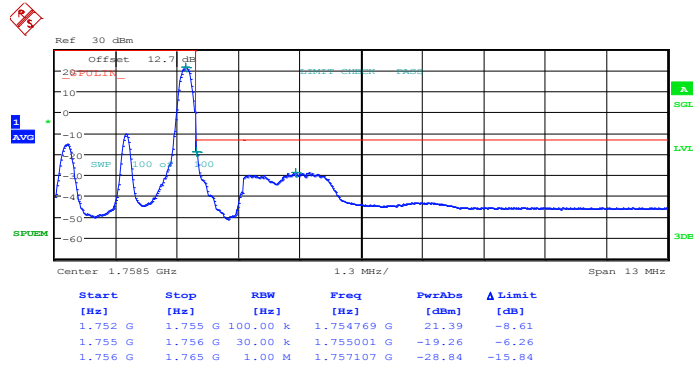

Date: 3.JUN.2014 22:25:27

Higher Band Edge Plot for QPSK-RB Size 15, RB Offset 0

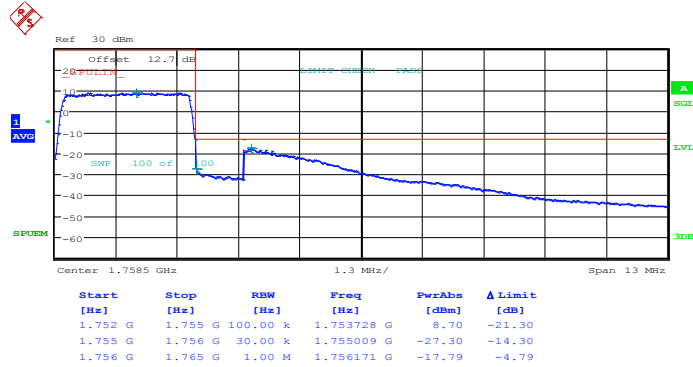

Date: 3.JUN.2014 22:27:03



Band :	LTE Band 4	Band Width :	3MHz / 16QAM
---------------	------------	---------------------	--------------

Lower Band Edge Plot for 16QAM-RB Size 1, RB Offset 0

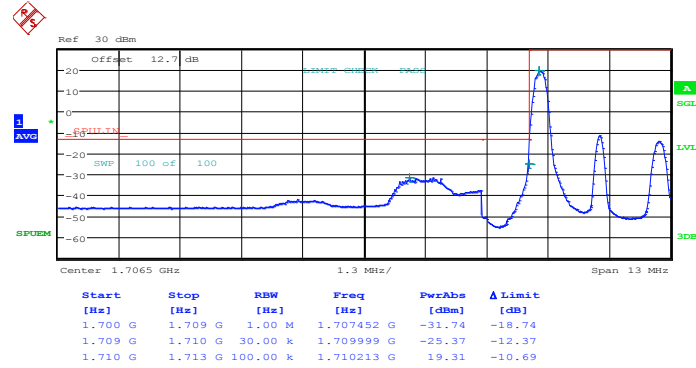

Date: 3.JUN.2014 22:16:38

Lower Band Edge Plot for 16QAM-RB Size 15, RB Offset 0

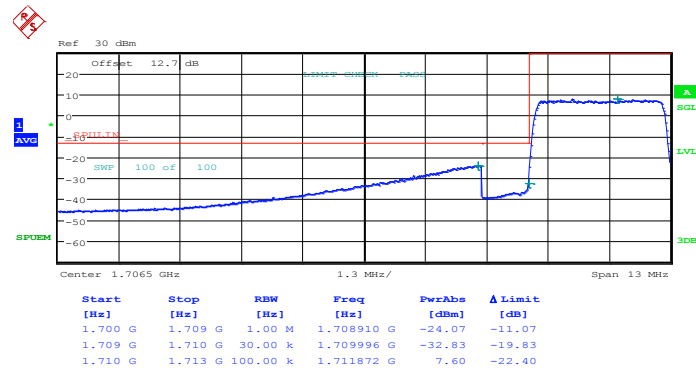

Date: 3.JUN.2014 22:18:14



Higher Band Edge Plot for 16QAM-RB Size 1, RB Offset 14

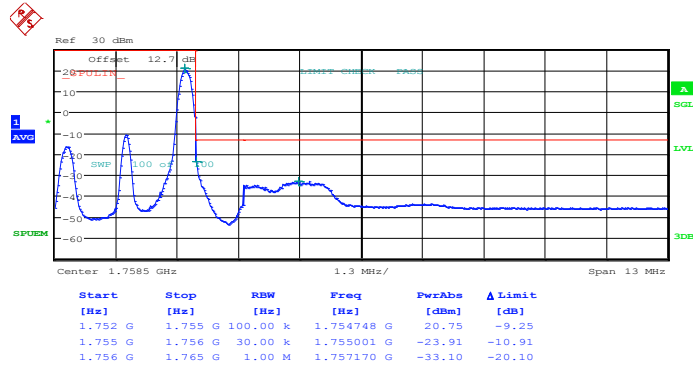

Date: 3.JUN.2014 22:26:15

Higher Band Edge Plot for 16QAM-RB Size 15, RB Offset 0

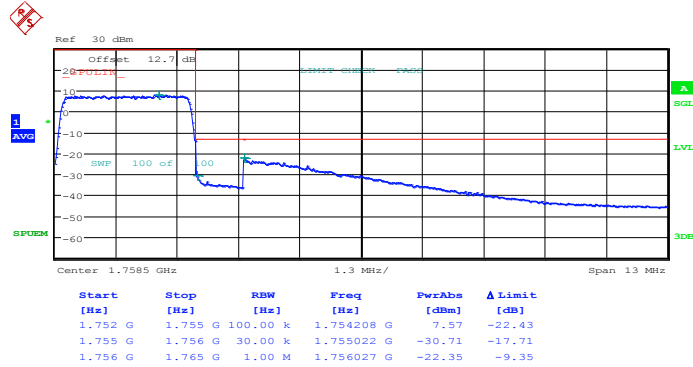

Date: 3.JUN.2014 22:27:51



Band :	LTE Band 4	Band Width :	5MHz / QPSK
---------------	------------	---------------------	-------------

Lower Band Edge Plot for QPSK-RB Size 1, RB Offset 0

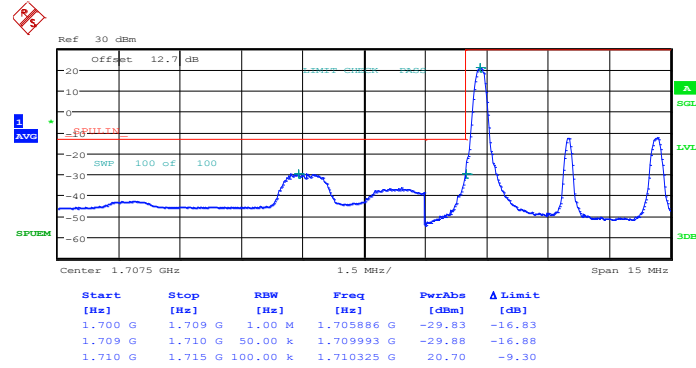

Date: 3.JUN.2014 22:31:55

Lower Band Edge Plot for QPSK-RB Size 25, RB Offset 0

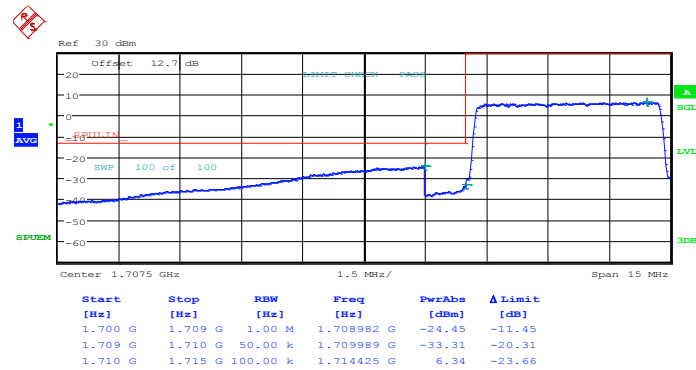

Date: 3.JUN.2014 22:33:31



Higher Band Edge Plot for QPSK-RB Size 1, RB Offset 24

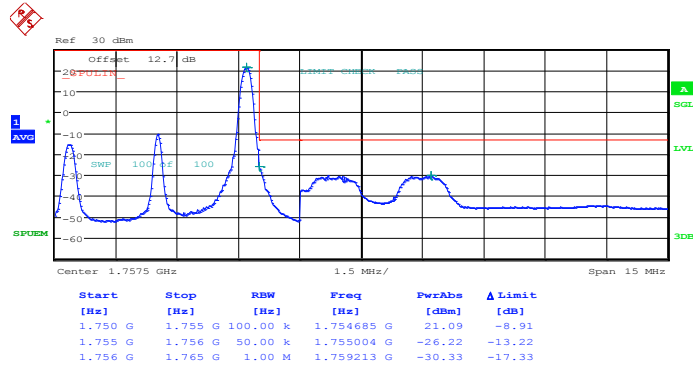

Date: 3.JUN.2014 22:41:33

Higher Band Edge Plot for QPSK-RB Size 25, RB Offset 0

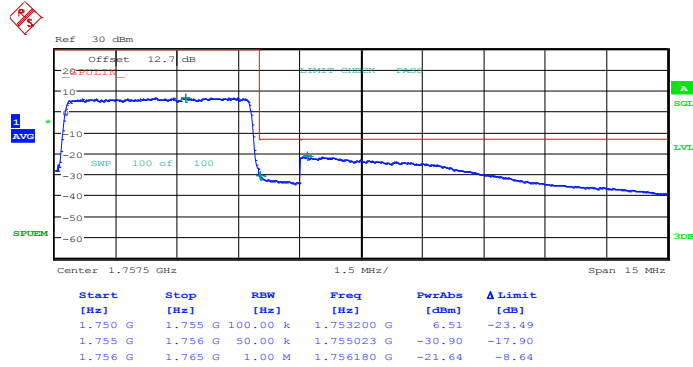

Date: 3.JUN.2014 22:43:09



Band :	LTE Band 4	Band Width :	5MHz / 16QAM
---------------	------------	---------------------	--------------

Lower Band Edge Plot for 16QAM-RB Size 1, RB Offset 0

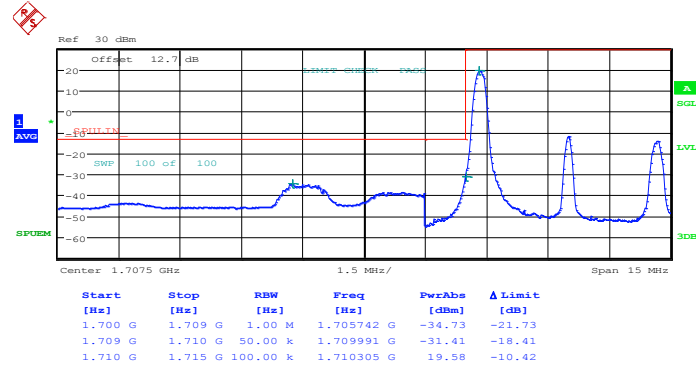

Date: 3.JUN.2014 22:32:43

Lower Band Edge Plot for 16QAM-RB Size 25, RB Offset 0

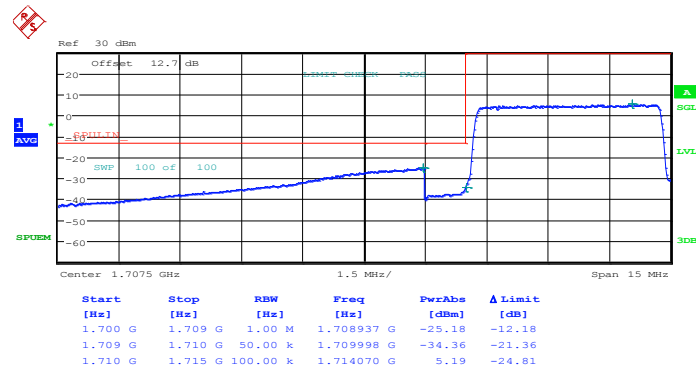

Date: 3.JUN.2014 22:34:19



Higher Band Edge Plot for 16QAM-RB Size 1, RB Offset 24

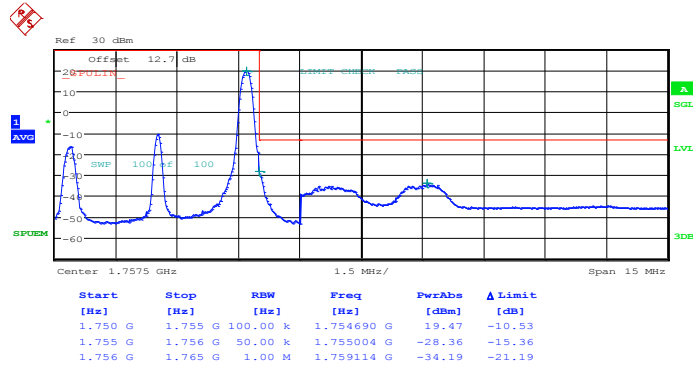

Date: 3.JUN.2014 22:42:21

Higher Band Edge Plot for 16QAM-RB Size 25, RB Offset 0

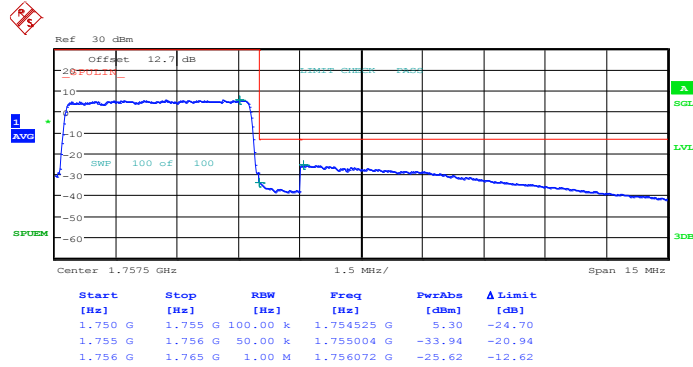

Date: 3.JUN.2014 22:43:57



Band :	LTE Band 4	Band Width :	10MHz / QPSK
---------------	------------	---------------------	--------------

Lower Band Edge Plot for QPSK-RB Size 1, RB Offset 0

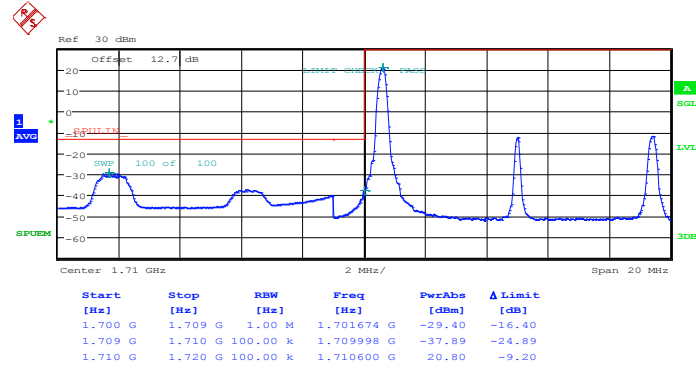

Date: 3.JUN.2014 22:48:01

Lower Band Edge Plot for QPSK-RB Size 50, RB Offset 0

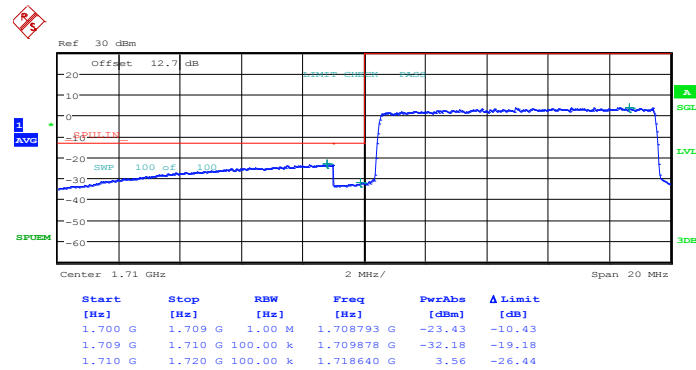

Date: 3.JUN.2014 22:49:37



Higher Band Edge Plot for QPSK-RB Size 1, RB Offset 49

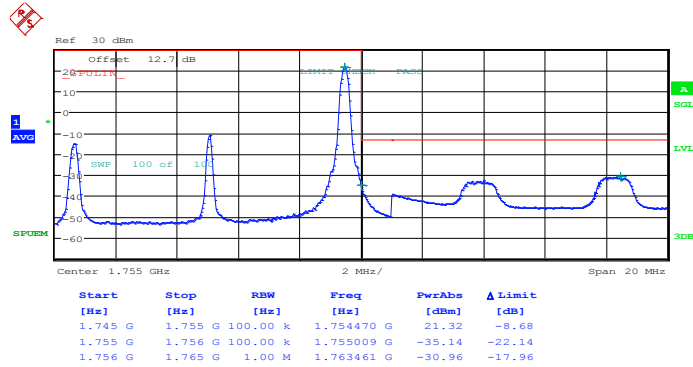

Date: 3.JUN.2014 22:57:38

Higher Band Edge Plot for QPSK-RB Size 50, RB Offset 0

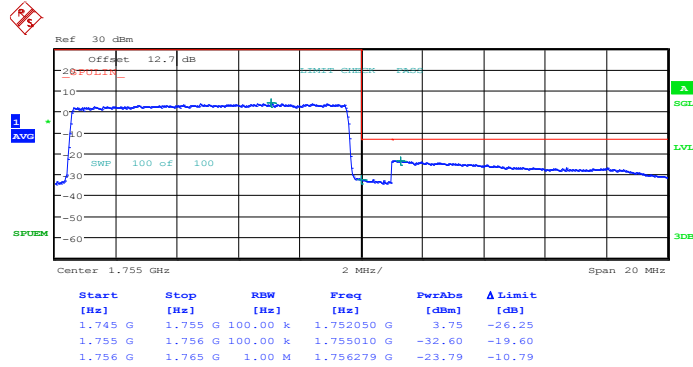

Date: 3.JUN.2014 22:59:15



Band :	LTE Band 4	Band Width :	10MHz / 16QAM
---------------	------------	---------------------	---------------

Lower Band Edge Plot for 16QAM-RB Size 1, RB Offset 0

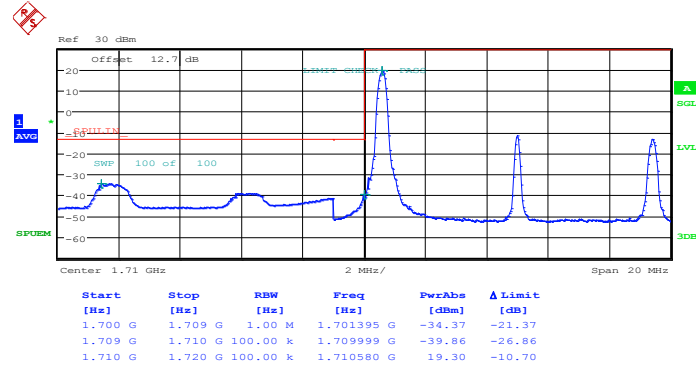

Date: 3.JUN.2014 22:48:49

Lower Band Edge Plot for 16QAM-RB Size 50, RB Offset 0

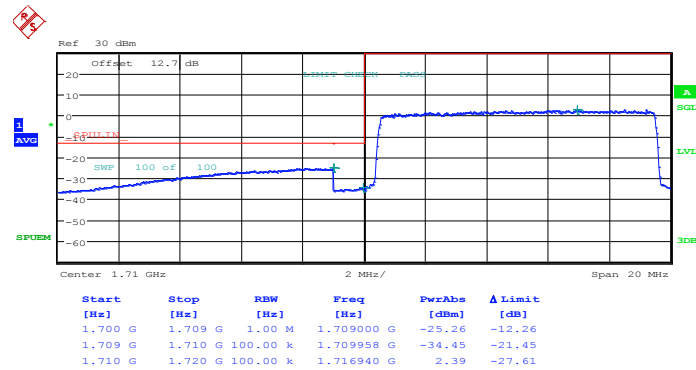

Date: 3.JUN.2014 22:50:25



Higher Band Edge Plot for 16QAM-RB Size 1, RB Offset 49

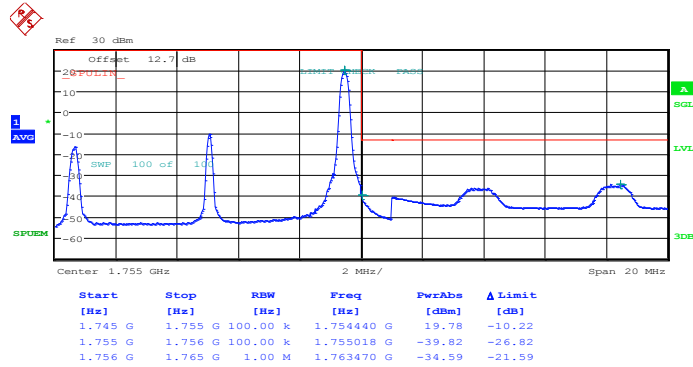

Date: 3.JUN.2014 22:58:27

Higher Band Edge Plot for 16QAM-RB Size 50, RB Offset 0

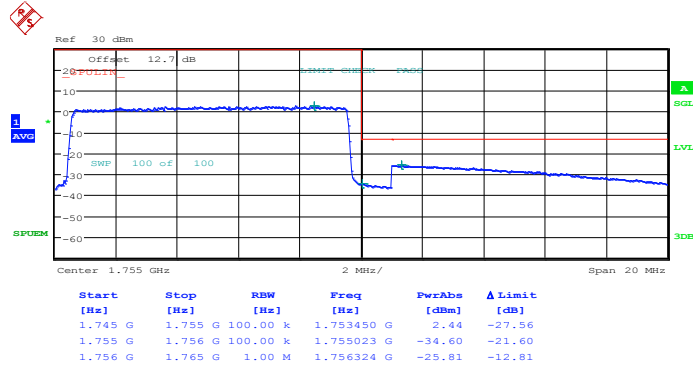

Date: 3.JUN.2014 23:00:03



Band :	LTE Band 4	Band Width :	15MHz / QPSK
---------------	------------	---------------------	--------------

Lower Band Edge Plot for QPSK-RB Size 1, RB Offset 0

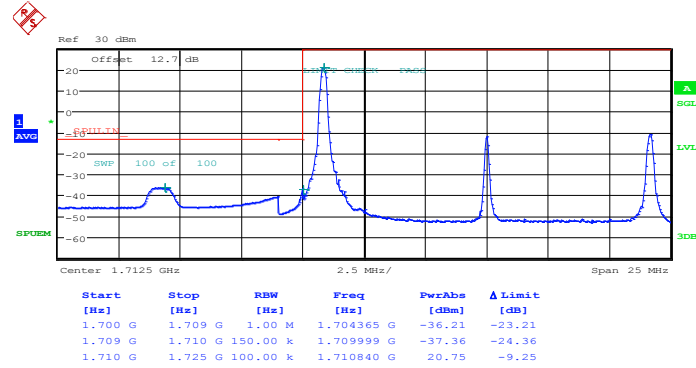

Date: 3.JUN.2014 23:04:07

Lower Band Edge Plot for QPSK-RB Size 75, RB Offset 0

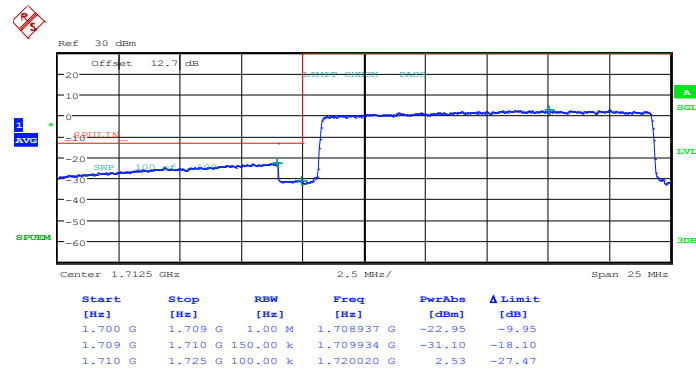

Date: 3.JUN.2014 23:05:43



Higher Band Edge Plot for QPSK-RB Size 1, RB Offset 74

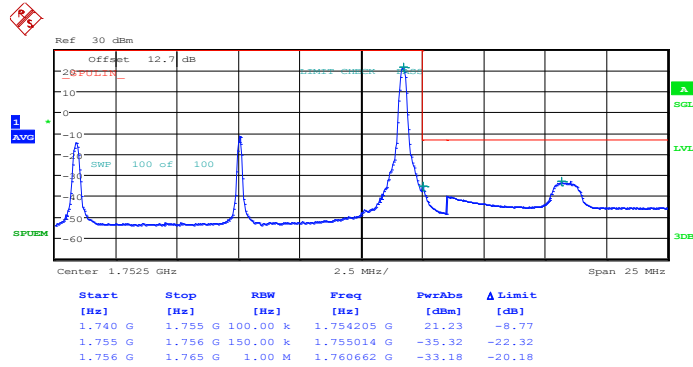

Date: 3.JUN.2014 23:13:44

Higher Band Edge Plot for QPSK-RB Size 75, RB Offset 0

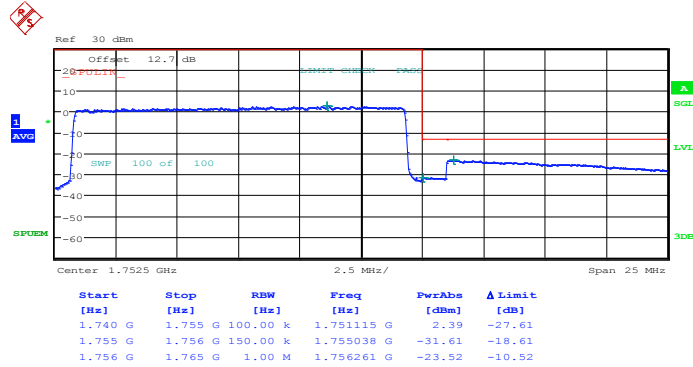

Date: 3.JUN.2014 23:15:20



Band :	LTE Band 4	Band Width :	15MHz / 16QAM
---------------	------------	---------------------	---------------

Lower Band Edge Plot for 16QAM-RB Size 1, RB Offset 0

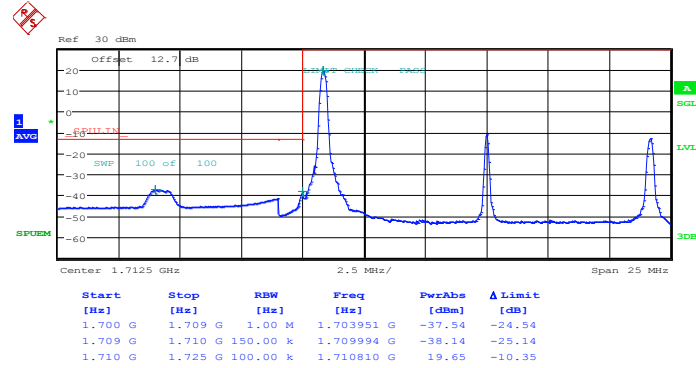

Date: 3.JUN.2014 23:04:55

Lower Band Edge Plot for 16QAM-RB Size 75, RB Offset 0

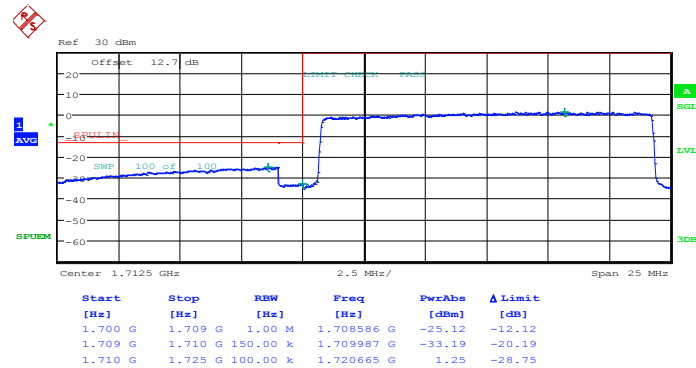

Date: 3.JUN.2014 23:06:31



Higher Band Edge Plot for 16QAM-RB Size 1, RB Offset 74

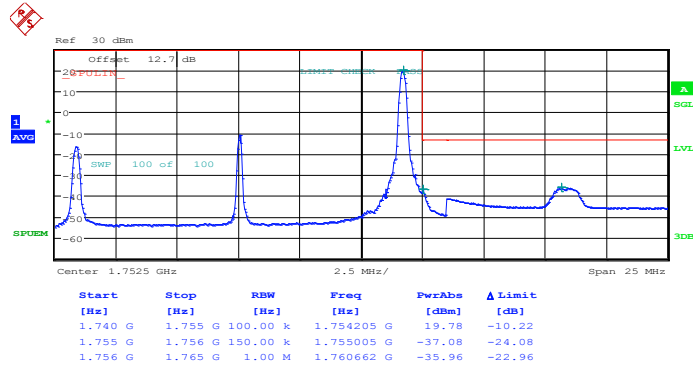

Date: 3.JUN.2014 23:14:32

Higher Band Edge Plot for 16QAM-RB Size 75, RB Offset 0

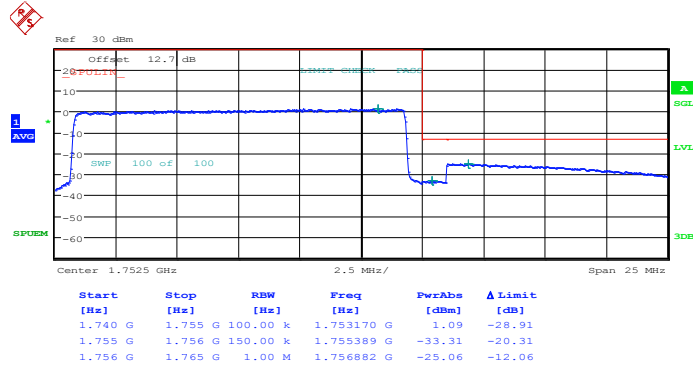

Date: 3.JUN.2014 23:16:08



Band :	LTE Band 4	Band Width :	20MHz / QPSK
---------------	------------	---------------------	--------------

Lower Band Edge Plot for QPSK-RB Size 1, RB Offset 0

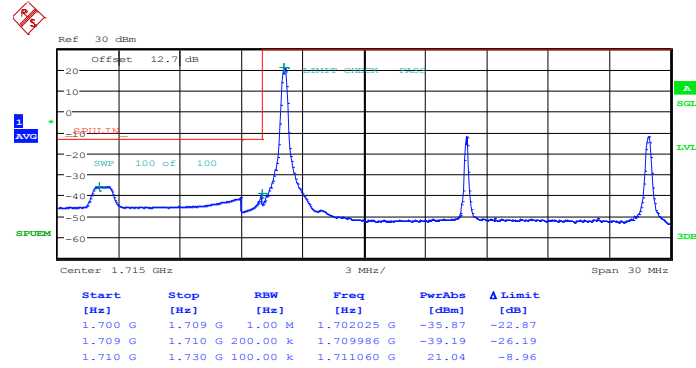

Date: 3.JUN.2014 23:20:12

Lower Band Edge Plot for QPSK-RB Size 100, RB Offset 0

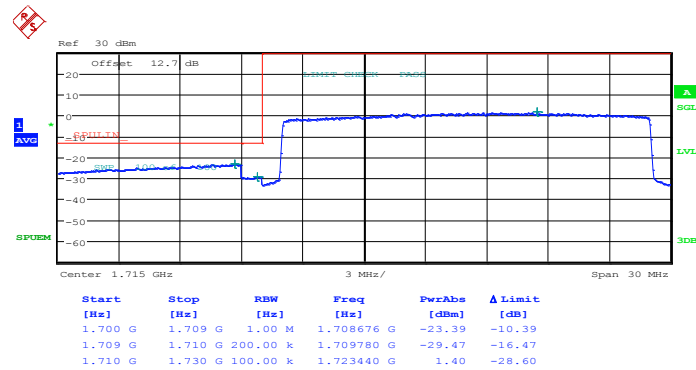

Date: 3.JUN.2014 23:21:48



Higher Band Edge Plot for QPSK-RB Size 1, RB Offset 99

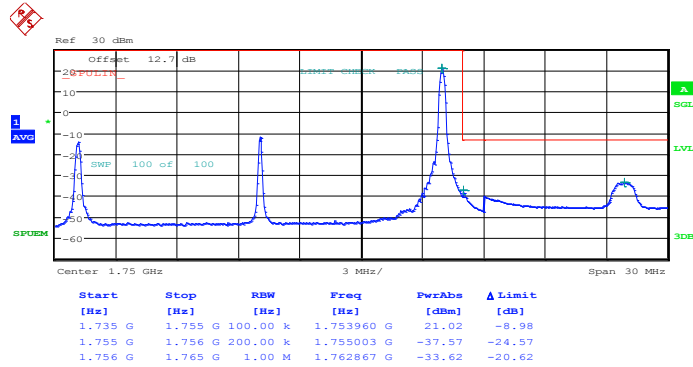

Date: 3.JUN.2014 23:29:48

Higher Band Edge Plot for QPSK-RB Size 100, RB Offset 0

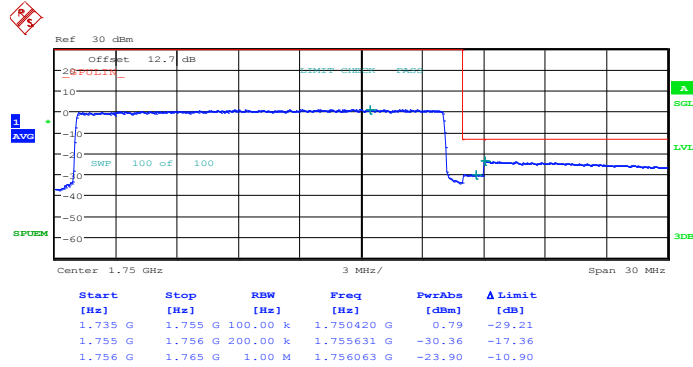

Date: 3.JUN.2014 23:31:24



Band :	LTE Band 4	Band Width :	20MHz / 16QAM
---------------	------------	---------------------	---------------

Lower Band Edge Plot for 16QAM-RB Size 1, RB Offset 0

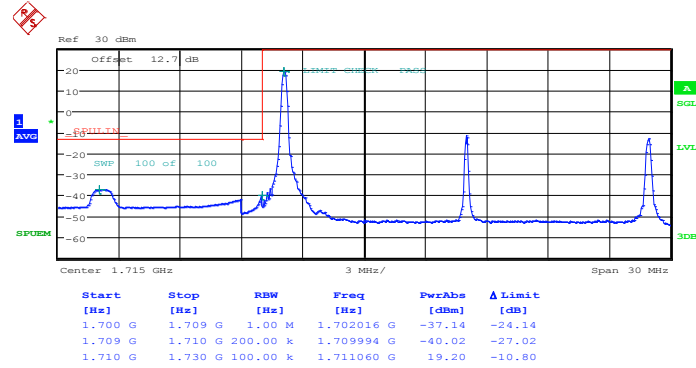

Date: 3.JUN.2014 23:21:00

Lower Band Edge Plot for 16QAM-RB Size 100, RB Offset 0

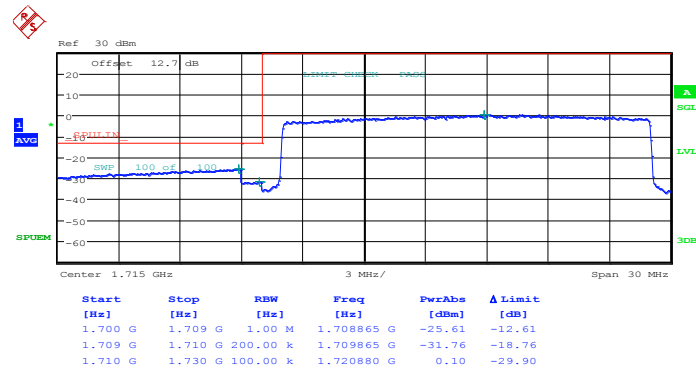

Date: 3.JUN.2014 23:22:36



Higher Band Edge Plot for 16QAM-RB Size 1, RB Offset 99

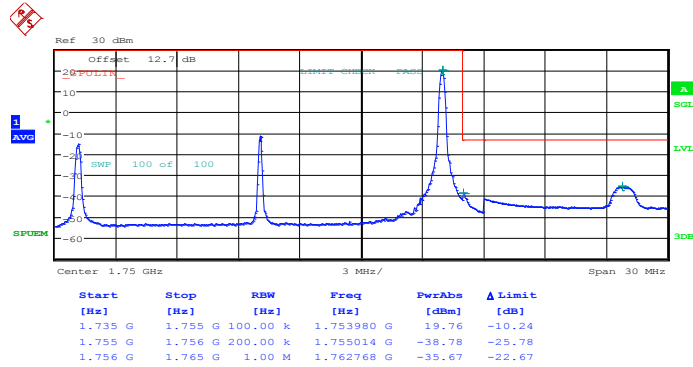

Date: 3.JUN.2014 23:30:36

Higher Band Edge Plot for 16QAM-RB Size 100, RB Offset 0

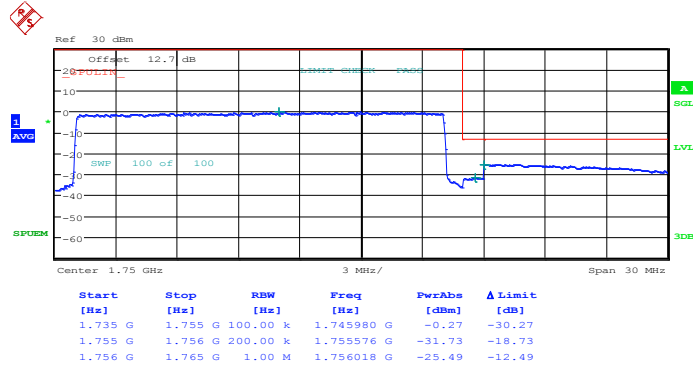

Date: 3.JUN.2014 23:32:12



Band :	LTE Band 7	Band Width :	5MHz / QPSK
---------------	------------	---------------------	-------------

Lower Band Edge Plot for QPSK-RB Size 1, RB Offset 0

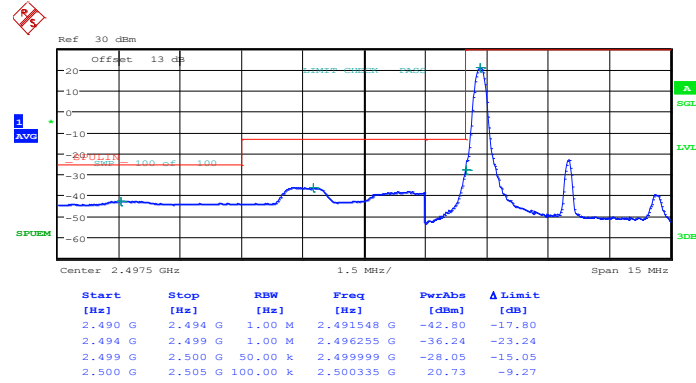

Date: 23.JUN.2014 14:52:41

Lower Band Edge Plot for QPSK-RB Size 25, RB Offset 0

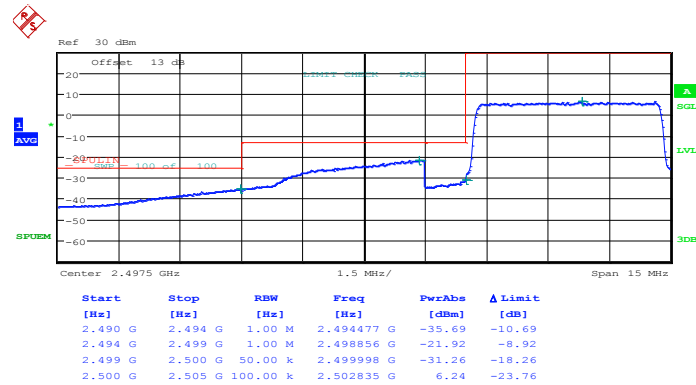

Date: 23.JUN.2014 14:54:11



Higher Band Edge Plot for QPSK-RB Size 1, RB Offset 24

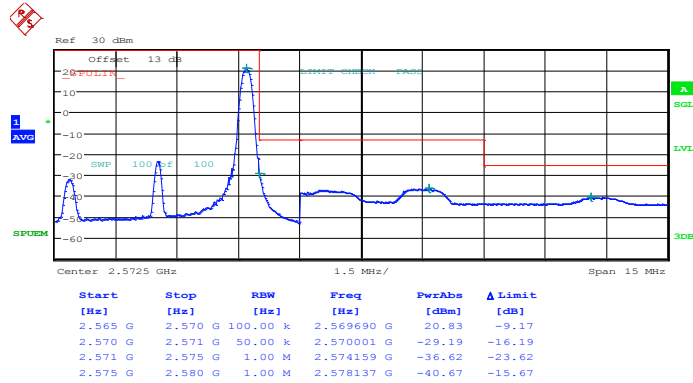

Date: 23.JUN.2014 14:55:40

Higher Band Edge Plot for QPSK-RB Size 25, RB Offset 0

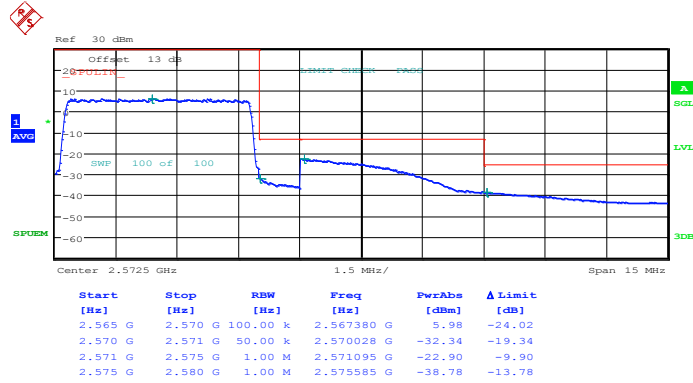

Date: 23.JUN.2014 14:57:10



Band :	LTE Band 7	Band Width :	5MHz / 16QAM
---------------	------------	---------------------	--------------

Lower Band Edge Plot for 16QAM-RB Size 1, RB Offset 0

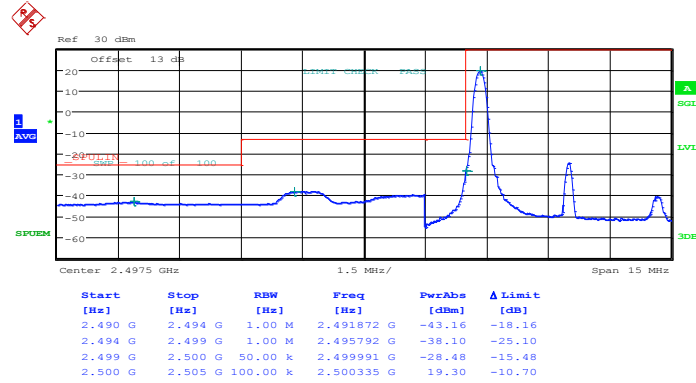

Date: 23.JUN.2014 14:53:26

Lower Band Edge Plot for 16QAM-RB Size 25, RB Offset 0

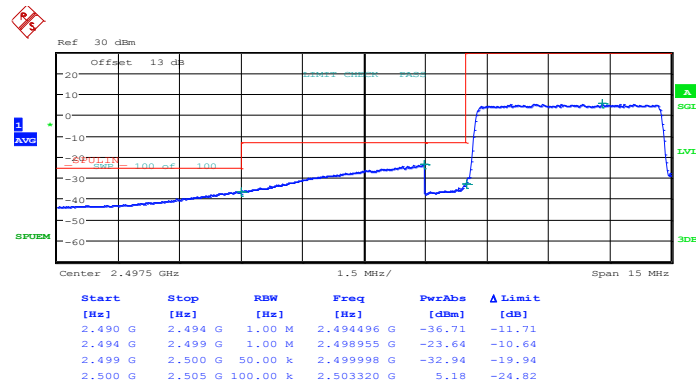

Date: 23.JUN.2014 14:54:55



Higher Band Edge Plot for 16QAM-RB Size 1, RB Offset 24

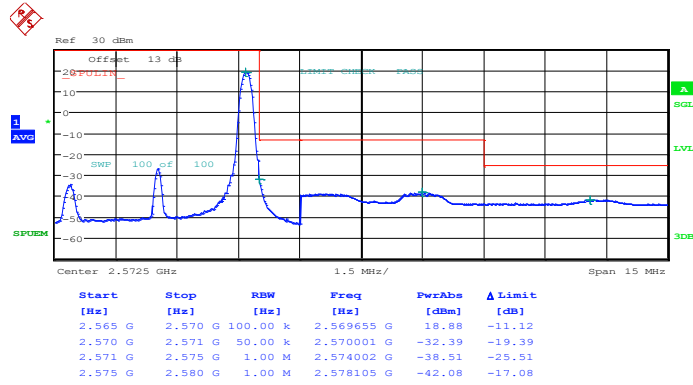

Date: 23.JUN.2014 14:56:25

Higher Band Edge Plot for 16QAM-RB Size 25, RB Offset 0

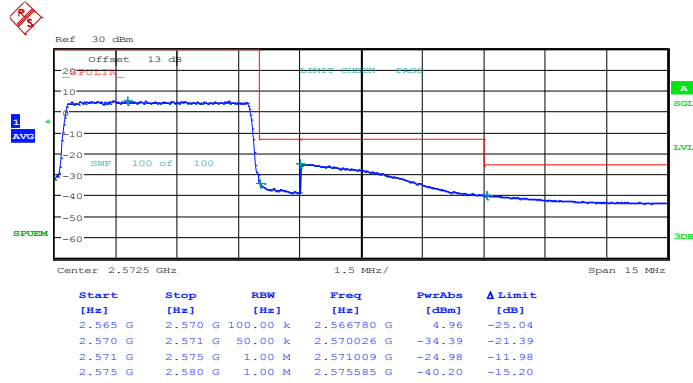

Date: 23.JUN.2014 14:57:55



Band :	LTE Band 7	Band Width :	10MHz / QPSK
---------------	------------	---------------------	--------------

Lower Band Edge Plot for QPSK-RB Size 1, RB Offset 0

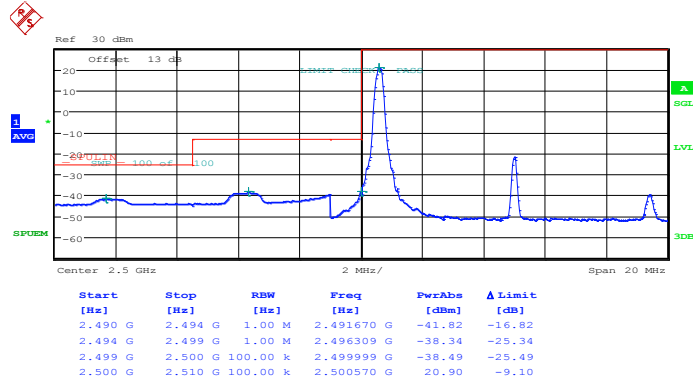

Date: 23.JUN.2014 14:58:44

Lower Band Edge Plot for QPSK-RB Size 50, RB Offset 0

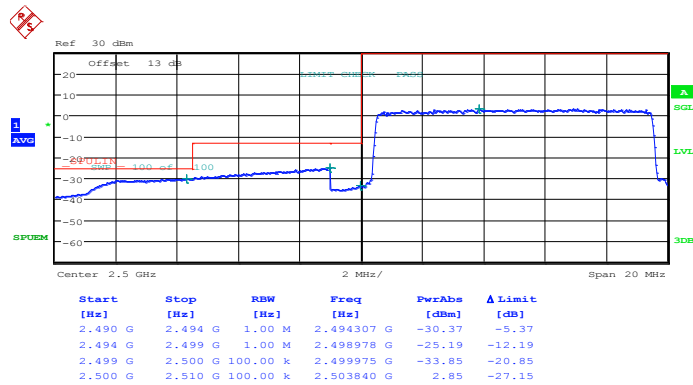

Date: 23.JUN.2014 15:00:14



Higher Band Edge Plot for QPSK-RB Size 1, RB Offset 49

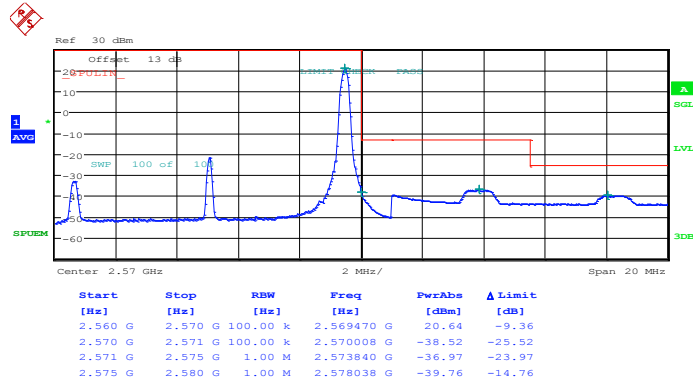

Date: 23.JUN.2014 15:01:44

Higher Band Edge Plot for QPSK-RB Size 50, RB Offset 0

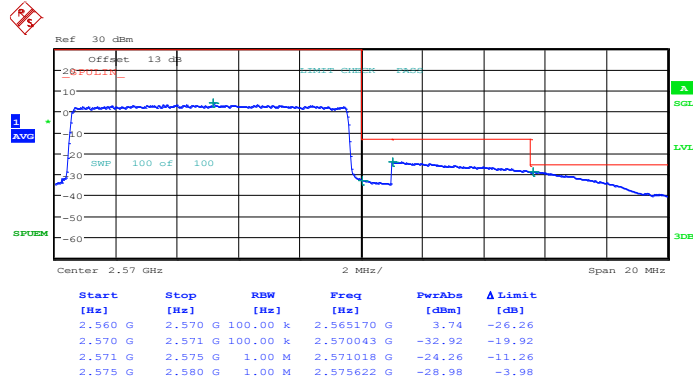

Date: 23.JUN.2014 15:03:14



Band :	LTE Band 7	Band Width :	10MHz / 16QAM
---------------	------------	---------------------	---------------

Lower Band Edge Plot for 16QAM-RB Size 1, RB Offset 0

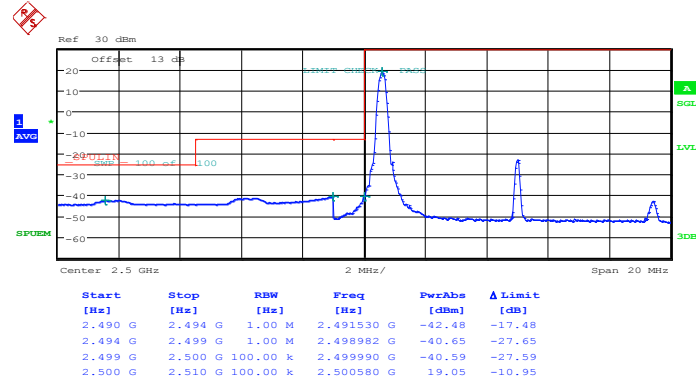

Date: 23.JUN.2014 14:59:29

Lower Band Edge Plot for 16QAM-RB Size 50, RB Offset 0

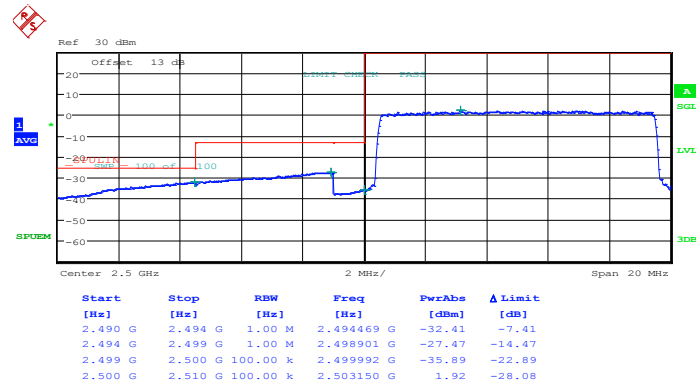

Date: 23.JUN.2014 15:00:59



Higher Band Edge Plot for 16QAM-RB Size 1, RB Offset 49

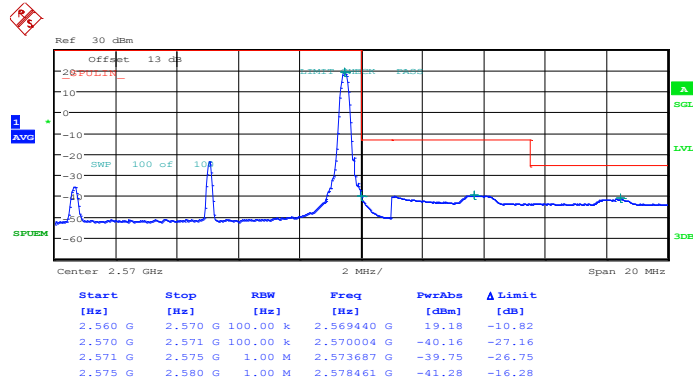

Date: 23.JUN.2014 15:02:29

Higher Band Edge Plot for 16QAM-RB Size 50, RB Offset 0

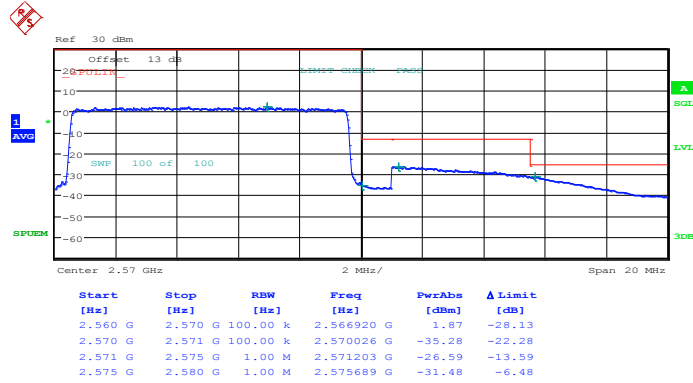

Date: 23.JUN.2014 15:03:59



Band :	LTE Band 7	Band Width :	15MHz / QPSK
---------------	------------	---------------------	--------------

Lower Band Edge Plot for QPSK-RB Size 1, RB Offset 0

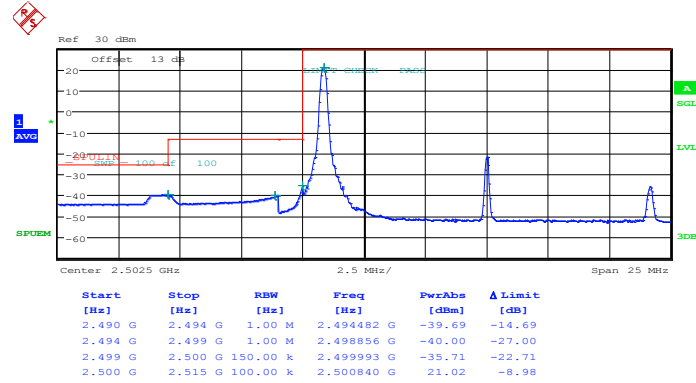

Date: 23.JUN.2014 15:04:48

Lower Band Edge Plot for QPSK-RB Size 75, RB Offset 0

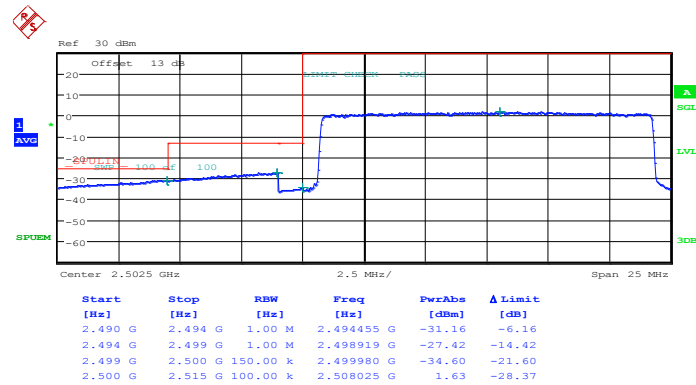

Date: 23.JUN.2014 15:06:18



Higher Band Edge Plot for QPSK-RB Size 1, RB Offset 74

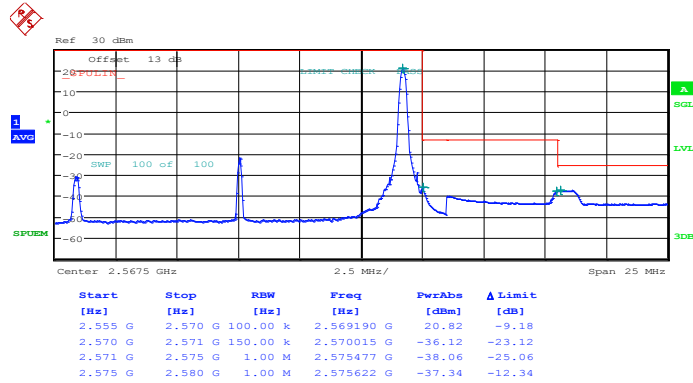

Date: 23.JUN.2014 15:07:48

Higher Band Edge Plot for QPSK-RB Size 75, RB Offset 0

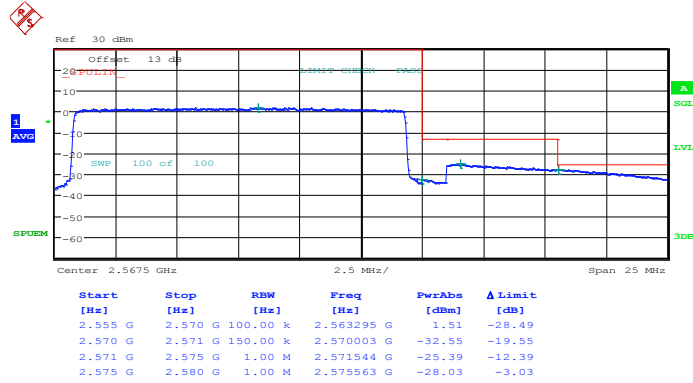

Date: 23.JUN.2014 15:09:17



Band :	LTE Band 7	Band Width :	15MHz / 16QAM
---------------	------------	---------------------	---------------

Lower Band Edge Plot for 16QAM-RB Size 1, RB Offset 0

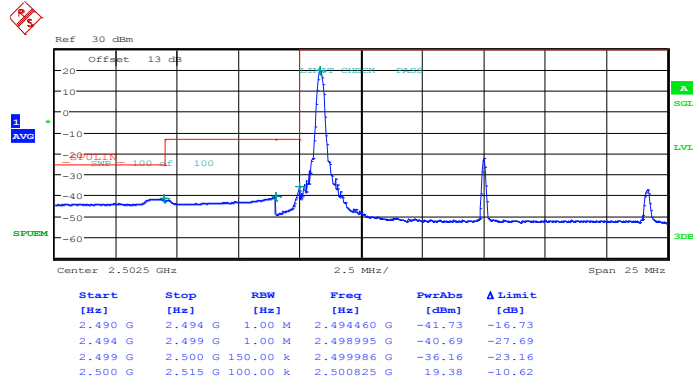

Date: 23.JUN.2014 15:05:33

Lower Band Edge Plot for 16QAM-RB Size 75, RB Offset 0

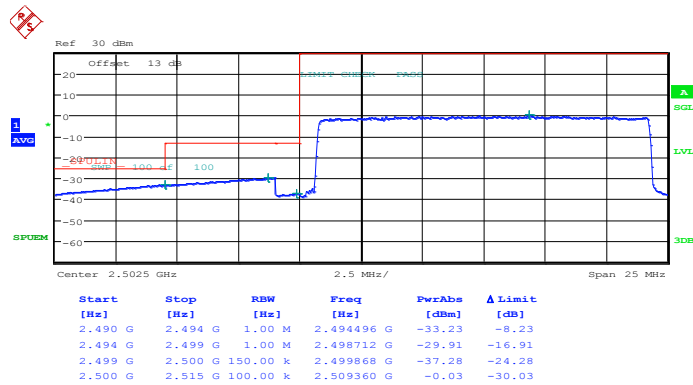

Date: 23.JUN.2014 15:07:03



Higher Band Edge Plot for 16QAM-RB Size 1, RB Offset 74

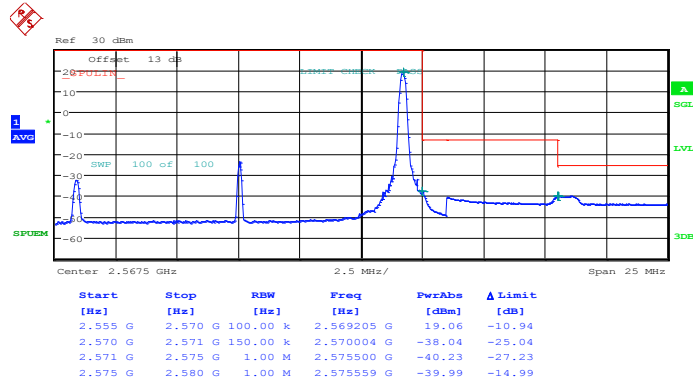

Date: 23.JUN.2014 15:08:33

Higher Band Edge Plot for 16QAM-RB Size 75, RB Offset 0

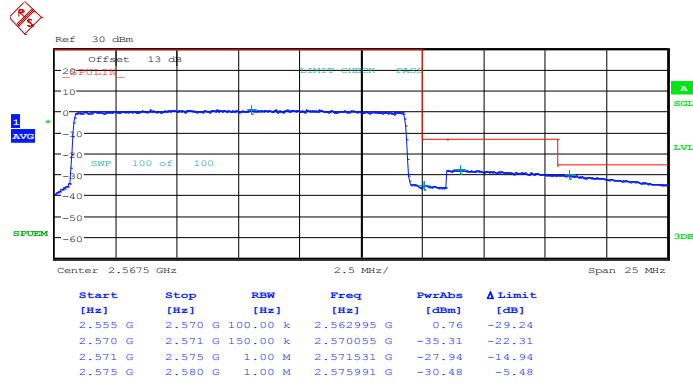

Date: 23.JUN.2014 15:10:02



Band :	LTE Band 7	Band Width :	20MHz / QPSK
---------------	------------	---------------------	--------------

Lower Band Edge Plot for QPSK-RB Size 1, RB Offset 0

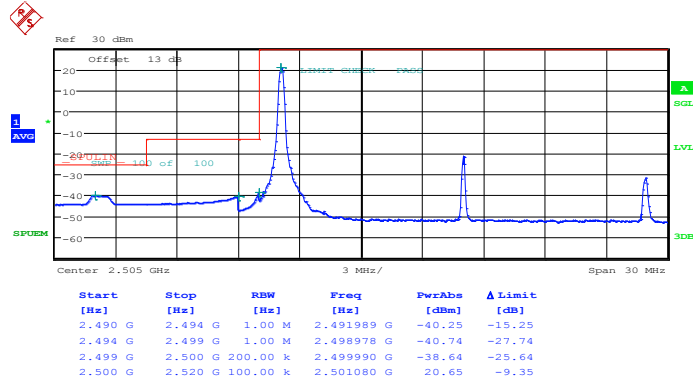

Date: 23.JUN.2014 15:10:52

Lower Band Edge Plot for QPSK-RB Size 100, RB Offset 0

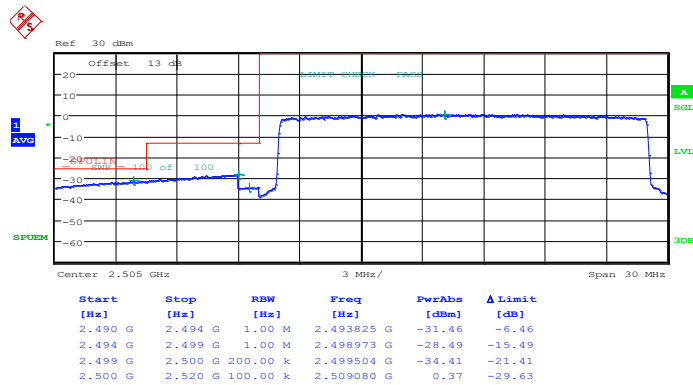

Date: 23.JUN.2014 15:12:22



Higher Band Edge Plot for QPSK-RB Size 1, RB Offset 99

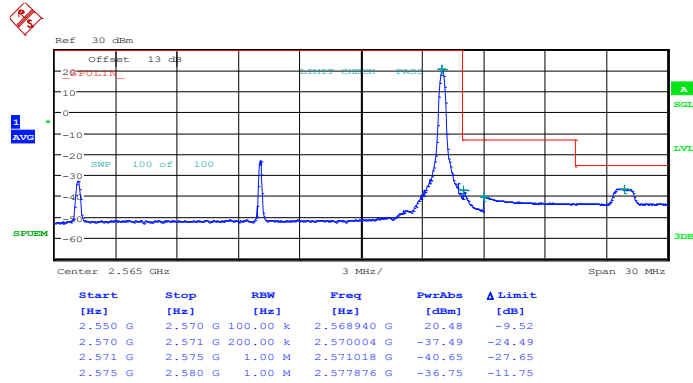

Date: 23.JUN.2014 15:13:52

Higher Band Edge Plot for QPSK-RB Size 100, RB Offset 0

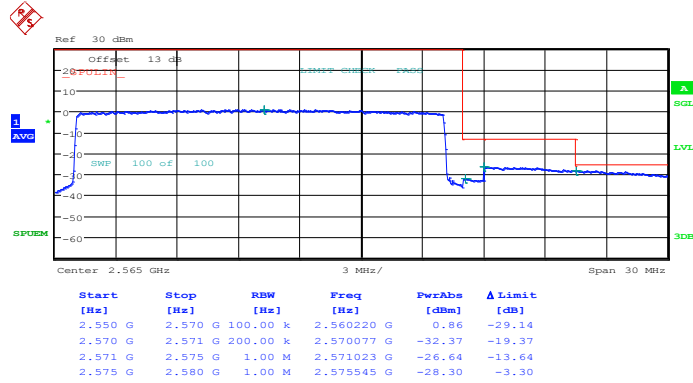

Date: 23.JUN.2014 15:16:06



Band :	LTE Band 7	Band Width :	20MHz / 16QAM
---------------	------------	---------------------	---------------

Lower Band Edge Plot for 16QAM-RB Size 1, RB Offset 0

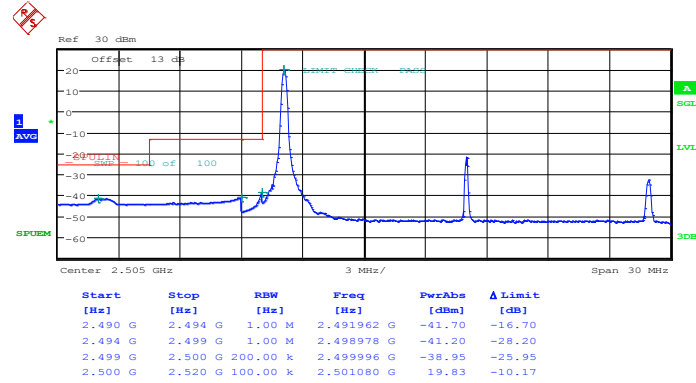

Date: 23.JUN.2014 15:11:37

Lower Band Edge Plot for 16QAM-RB Size 100, RB Offset 0

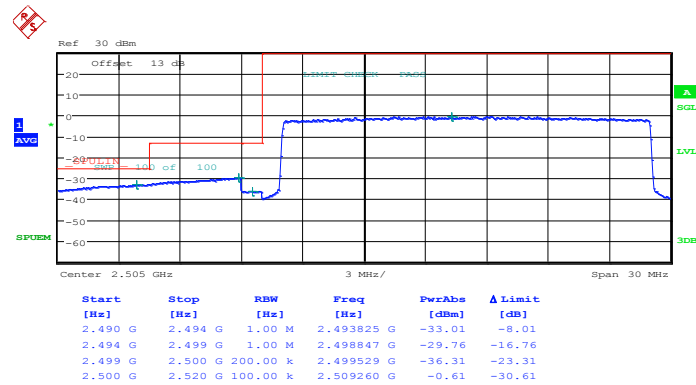

Date: 23.JUN.2014 15:13:07



Higher Band Edge Plot for 16QAM-RB Size 1, RB Offset 99

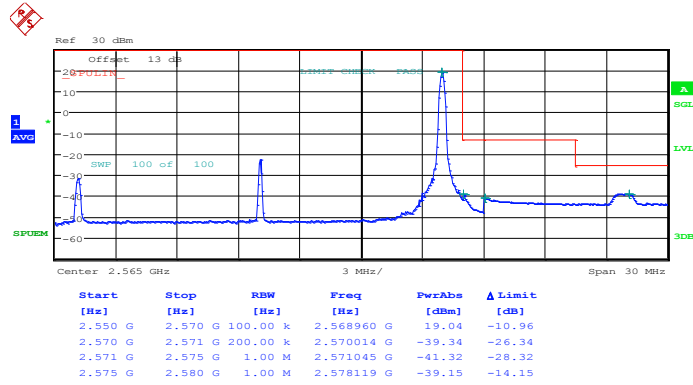

Date: 23.JUN.2014 15:14:36

Higher Band Edge Plot for 16QAM-RB Size 100, RB Offset 0

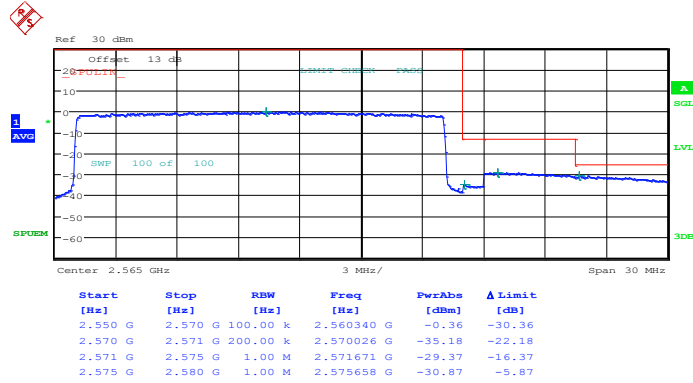

Date: 23.JUN.2014 15:15:21



3.6 Conducted Spurious Emission Measurement

3.6.1 Description of Conducted Spurious Emission Measurement

The power of any emission outside of the authorized operating frequency ranges must be lower than the transmitter power (P) by a factor of at least $43 + 10 \log (P)$ dB.

The power of any emission outside of the authorized operating frequency ranges must be lower than the transmitter power (P) by a factor of at least $55 + 10 \log (P)$ dB.

It is measured by means of a calibrated spectrum analyzer and scanned from 30MHz up to a frequency including its 10th harmonic.

3.6.2 Measuring Instruments

The measuring equipment is listed in the section 4 of this test report.

3.6.3 Test Procedures

1. The EUT was connected to spectrum analyzer and system simulator via a power divider.
2. The RF output of EUT was connected to the spectrum analyzer by RF cable and attenuator. The path loss was compensated to the results for each measurement.
3. The middle channel for the highest RF power within the transmitting frequency was measured.
4. The conducted spurious emission for the whole frequency range was taken.
5. Make the measurement with the spectrum analyzer's RBW = 1MHz, VBW = 3MHz, taking the record of maximum spurious emission.
6. The RF fundamental frequency should be excluded against the limit line in the operating frequency band.
7. The limit line is derived from $43 + 10\log(P)$ dB below the transmitter power P(Watts)
= $P(W) - [43 + 10\log(P)]$ (dB)
= $[30 + 10\log(P)]$ (dBm) - $[43 + 10\log(P)]$ (dB)
= -13dBm.
8. The limit line is derived from $55 + 10\log(P)$ dB below the transmitter power P(Watts)

3.6.4 Test Setup

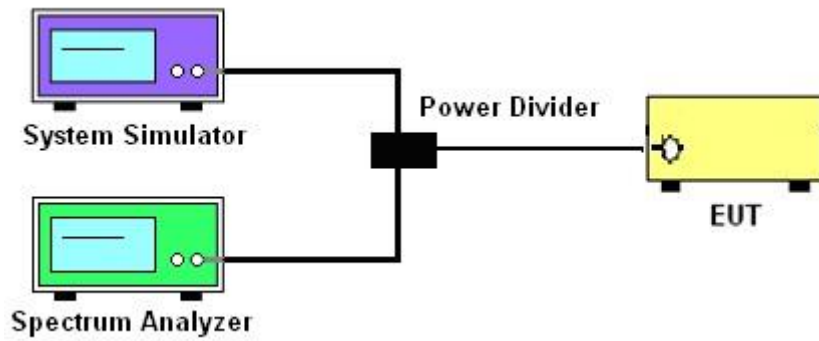



3.6.5 Test Result (Plots) of Conducted Spurious Emission

Band :	LTE Band 4	Channel :	CH20175 (Middle)
Band Width :	1.4MHz		

QPSK (RB Size 1, RB Offset 0)

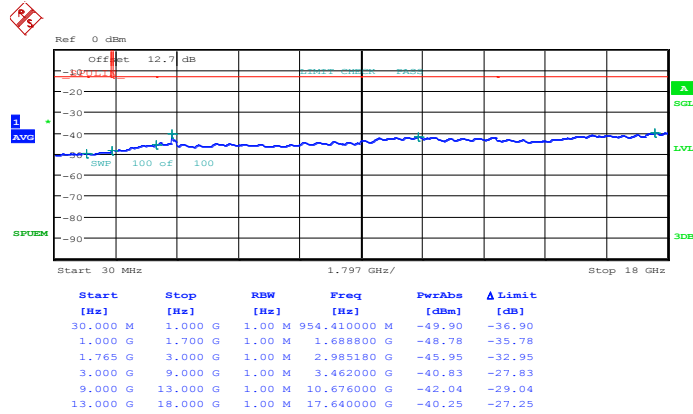

Date: 3.JUN.2014 21:39:09

16QAM (RB Size 1, RB Offset 0)

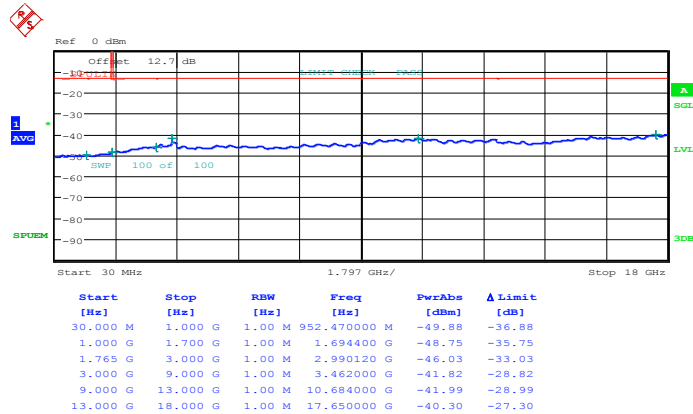

Date: 3.JUN.2014 21:40:10



Band :	LTE Band 4	Channel :	CH20175 (Middle)
Band Width :	3MHz		

QPSK (RB Size 1, RB Offset 0)

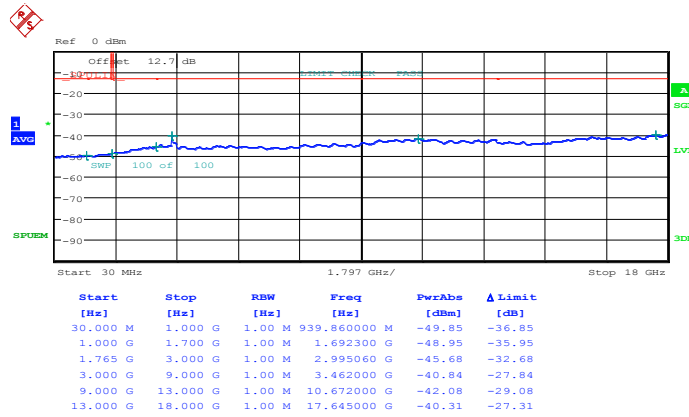

Date: 3.JUN.2014 22:22:28

16QAM (RB Size 1, RB Offset 0)

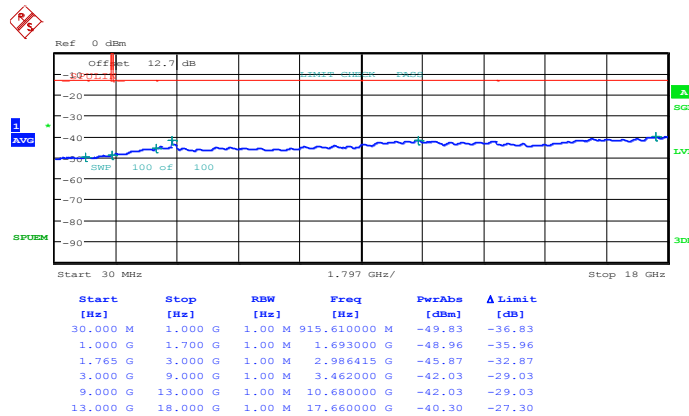

Date: 3.JUN.2014 22:23:29



Band :	LTE Band 4	Channel :	CH20175 (Middle)
Band Width :	5MHz		

QPSK (RB Size 1, RB Offset 0)

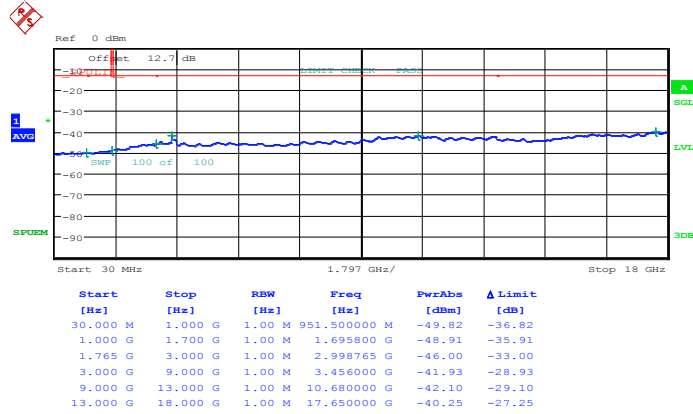

Date: 3.JUN.2014 22:38:31

16QAM (RB Size 1, RB Offset 0)

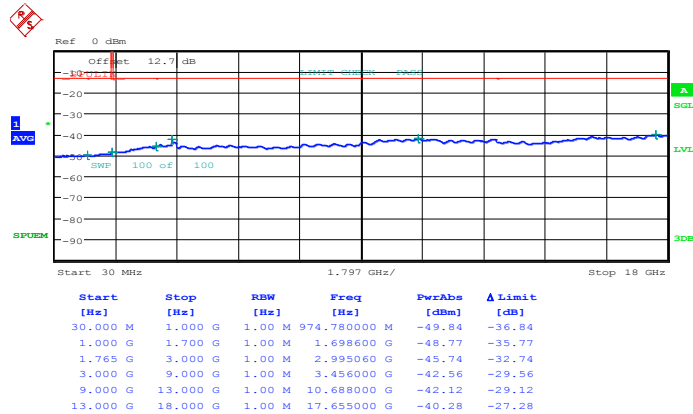

Date: 3.JUN.2014 22:39:32



Band :	LTE Band 4	Channel :	CH20175 (Middle)
Band Width :	10MHz		

QPSK (RB Size 1, RB Offset 0)

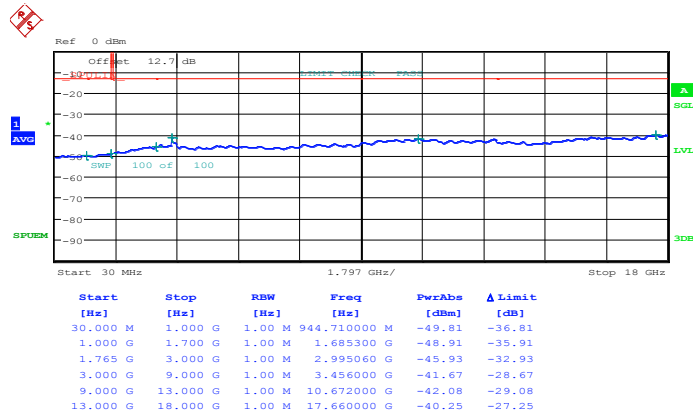

Date: 3.JUN.2014 22:54:39

16QAM (RB Size 1, RB Offset 0)

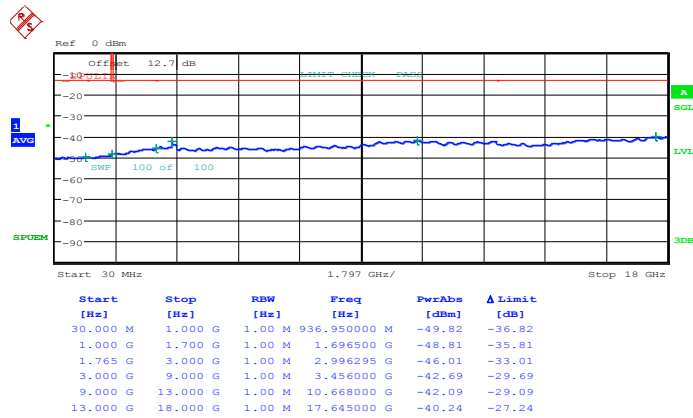

Date: 3.JUN.2014 22:55:40



Band :	LTE Band 4	Channel :	CH20175 (Middle)
Band Width :	15MHz		

QPSK (RB Size 1, RB Offset 0)

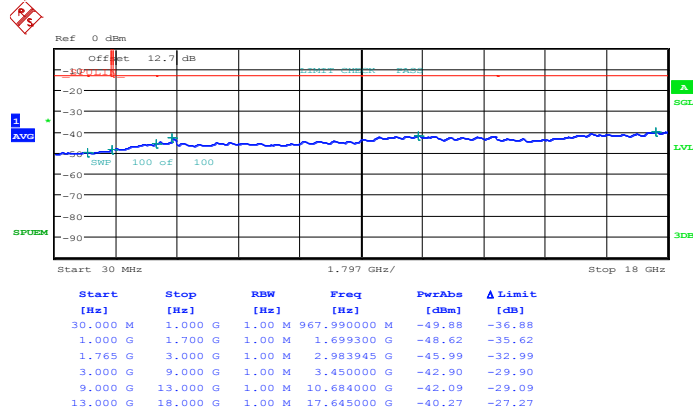

Date: 3.JUN.2014 23:10:45

16QAM (RB Size 1, RB Offset 0)

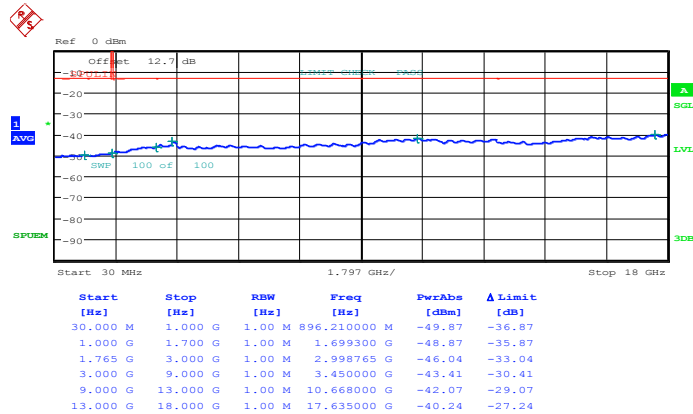

Date: 3.JUN.2014 23:11:46



Band :	LTE Band 4	Channel :	CH20175 (Middle)
Band Width :	20MHz		

QPSK (RB Size 1, RB Offset 0)

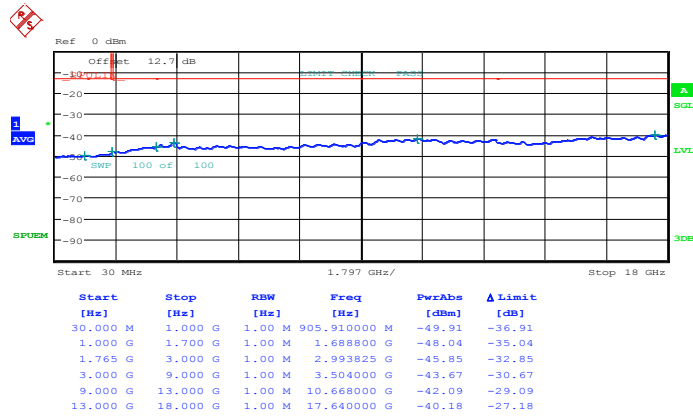

Date: 3.JUN.2014 23:26:49

16QAM (RB Size 1, RB Offset 0)

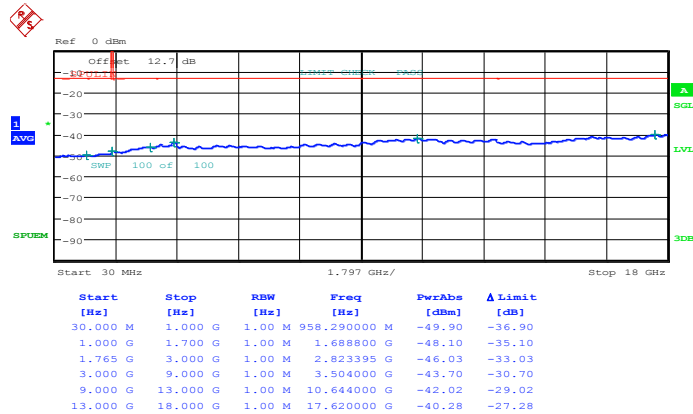

Date: 3.JUN.2014 23:27:50



Band :	LTE Band 7	Channel :	CH21100 (Middle)
Band Width :	5MHz		

QPSK (RB Size 1, RB Offset 0)

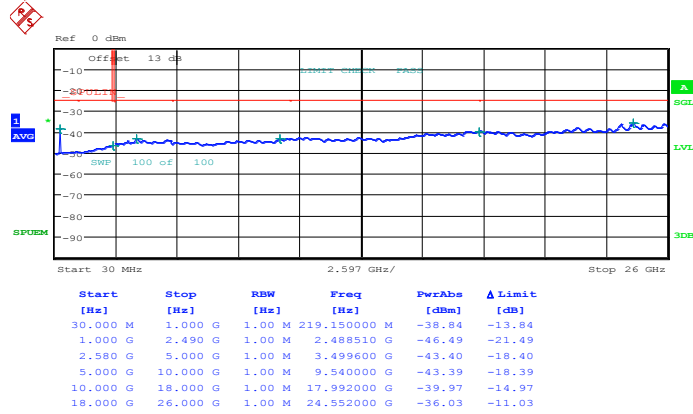

Date: 3.JUN.2014 23:56:12

16QAM (RB Size 1, RB Offset 0)

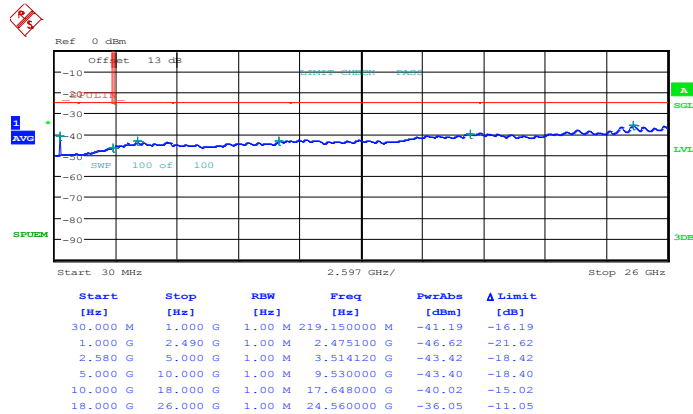

Date: 3.JUN.2014 23:57:15



Band :	LTE Band 7	Channel :	CH21100 (Middle)
Band Width :	10MHz		

QPSK (RB Size 1, RB Offset 0)

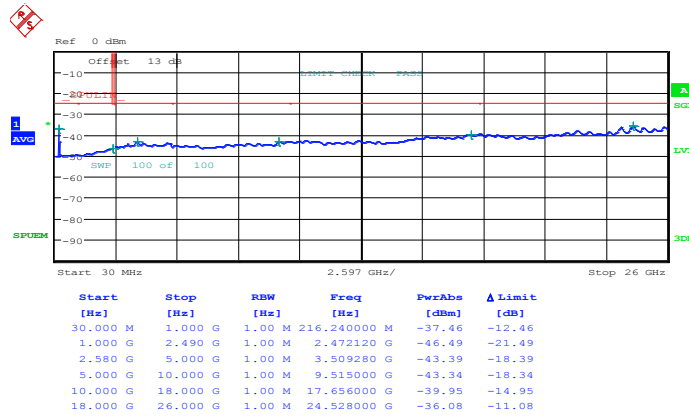

Date: 4.JUN.2014 00:12:25

16QAM (RB Size 1, RB Offset 0)

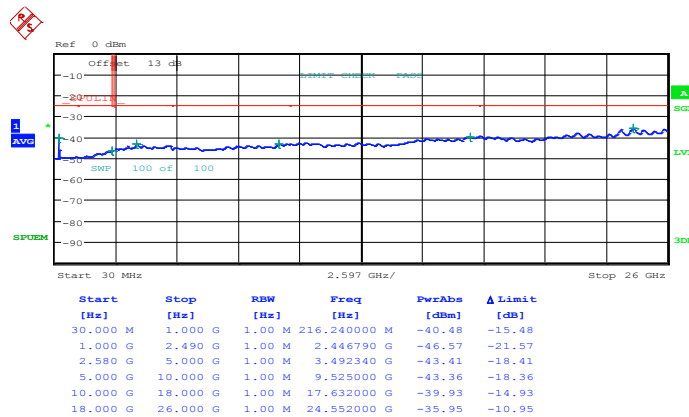

Date: 4.JUN.2014 00:13:28



Band :	LTE Band 7	Channel :	CH21100 (Middle)
Band Width :	15MHz		

QPSK (RB Size 1, RB Offset 0)

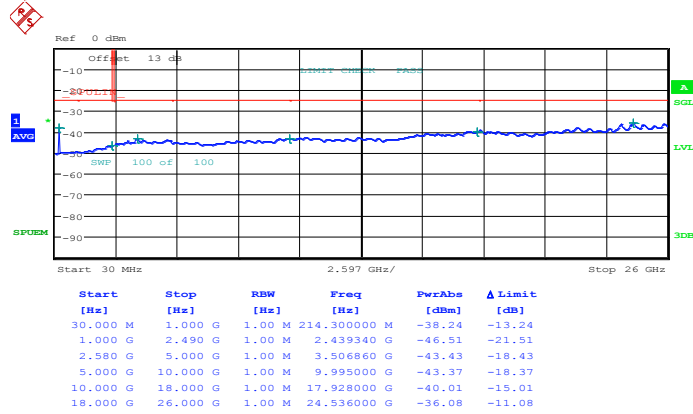

Date: 4.JUN.2014 00:28:38

16QAM (RB Size 1, RB Offset 0)

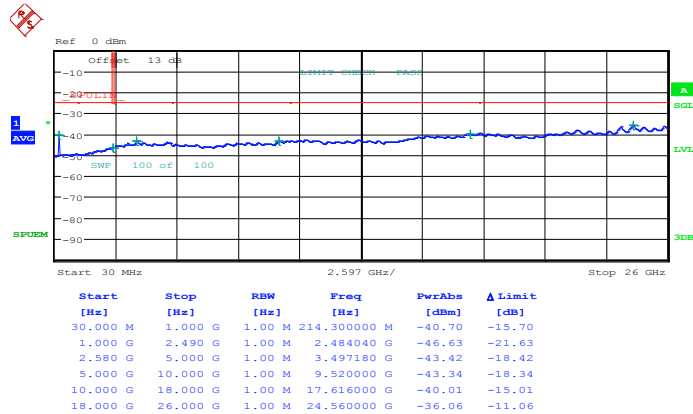

Date: 4.JUN.2014 00:29:42



Band :	LTE Band 7	Channel :	CH21100 (Middle)
Band Width :	20MHz		

QPSK (RB Size 1, RB Offset 0)

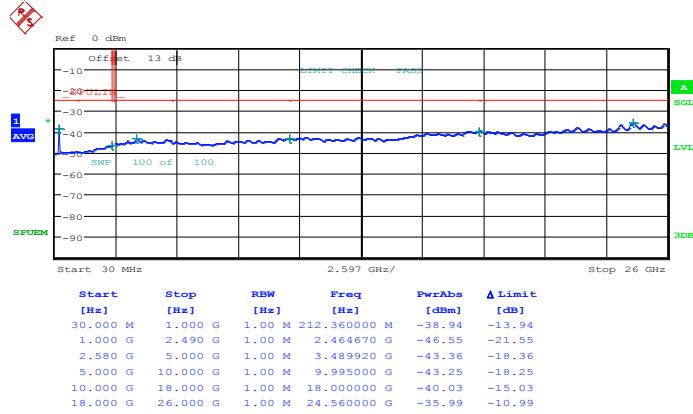

Date: 4.JUN.2014 01:12:12

16QAM (RB Size 1, RB Offset 0)

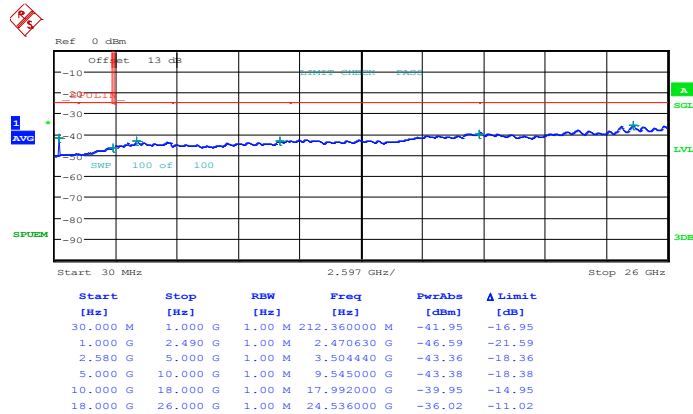

Date: 4.JUN.2014 01:13:16



3.7 Radiated Spurious Emission Measurement

3.7.1 Description of Radiated Spurious Emission

The radiated spurious emission was measured by substitution method according to ANSI / TIA / EIA-603-C-2004. The power of any emission outside of the authorized operating frequency ranges must be attenuated below the transmitter power (P) by a factor of at least $43 + 10 \log (P)$ dB.

The power of any emission outside of the authorized operating frequency ranges must be attenuated below the transmitter power (P) by a factor of at least $55 + 10 \log (P)$ dB.

The spectrum is scanned from 30 MHz up to a frequency including its 10th harmonic.

3.7.2 Measuring Instruments

The measuring equipment is listed in the section 4 of this test report.

3.7.3 Test Procedures

1. The EUT was placed on a rotatable wooden table with 0.8 meter above ground.
2. The EUT was set 3 meters from the receiving antenna, which was mounted on the antenna tower.
3. The table was rotated 360 degrees to determine the position of the highest spurious emission.
4. The height of the receiving antenna is varied between one meter and four meters to search the maximum spurious emission for both horizontal and vertical polarizations.
5. Make the measurement with the spectrum analyzer's RBW = 1MHz, VBW = 3MHz, taking the record of maximum spurious emission.
6. A horn antenna was substituted in place of the EUT and was driven by a signal generator.
7. Tune the output power of signal generator to the same emission level with EUT maximum spurious emission.
8. Taking the record of output power at antenna port.
9. Repeat step 7 to step 8 for another polarization.
10. The RF fundamental frequency should be excluded against the limit line in the operating frequency band.

The limit line is derived from $43 + 10\log(P)$ dB below the transmitter power P(Watts)
= P(W)- [43 + 10log(P)] (dB)
= [30 + 10log(P)] (dBm) - [43 + 10log(P)] (dB)
= -13dBm.

11. The limit line is derived from $55 + 10\log(P)$ dB below the transmitter power P(Watts)
12. EIRP (dBm) = S.G. Power – Tx Cable Loss + Tx Antenna Gain
13. ERP (dBm) = EIRP - 2.15

3.7.4 Test Setup

For radiated emissions from 30MHz to 1GHz

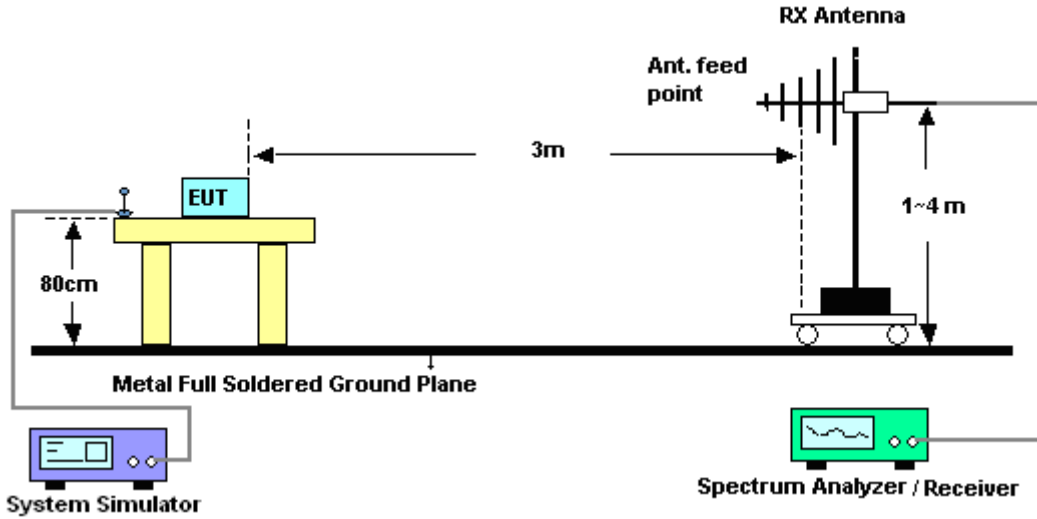

For radiated emissions above 1GHz

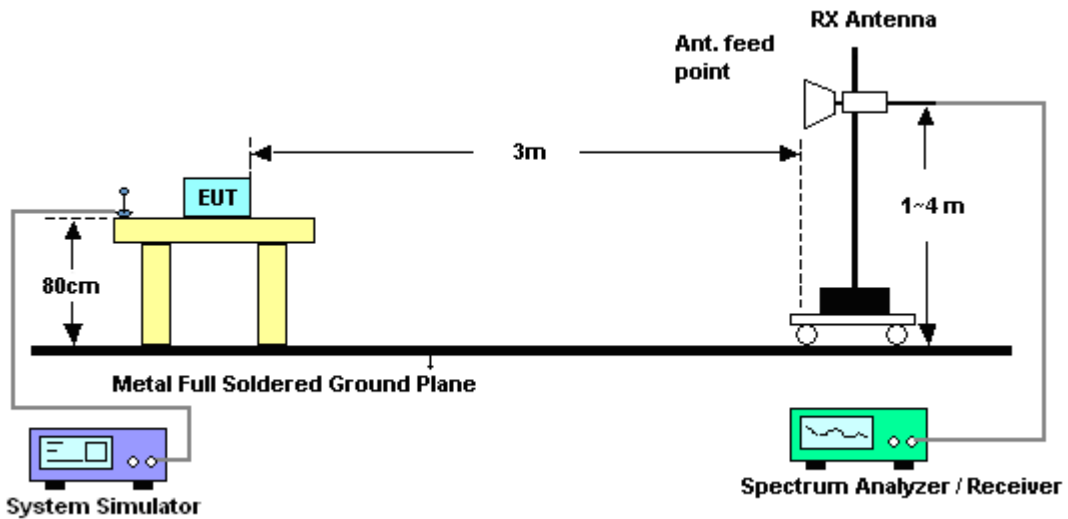



3.7.5 Test Result of Field Strength of Spurious Radiated

Band :	LTE Band 4					Temperature :	21~24°C		
Test Mode :	1.4MHz QPSK RB Size 1 Offset 0					Relative Humidity :	44~48%		
Test Engineer :	Kai Wang, Stan Hsieh, and Ken Wu					Polarization :	Horizontal		
Remark :	Spurious emissions within 30-10th harmonic were found more than 20dB below limit line.								
Frequency (MHz)	EIRP (dBm)	Limit (dBm)	Over Limit (dB)	SPA Reading (dBm)	S.G. Power (dBm)	TX Cable loss (dB)	TX Antenna Gain (dBi)	Polarization (H/V)	Result
3462	-50.29	-13	-37.29	-64.09	-54.12	4.48	8.31	H	Pass
5198	-28.03	-13	-15.03	-46.4	-32.67	5.332	9.98	H	Pass
6927	-31.72	-13	-18.72	-57.76	-36.96	6.1	11.34	H	Pass
8663	-34.12	-13	-21.12	-59.41	-39.04	8.25	13.17	H	Pass
10392	-37.36	-13	-24.36	-66.26	-41.65	8.65	12.94	H	Pass
12120	-34.05	-13	-21.05	-65.53	-38.36	8.59	12.90	H	Pass

Band :	LTE Band 4					Temperature :	21~24°C		
Test Mode :	1.4MHz QPSK RB Size 1 Offset 0					Relative Humidity :	44~48%		
Test Engineer :	Kai Wang, Stan Hsieh, and Ken Wu					Polarization :	Vertical		
Remark :	Spurious emissions within 30-10th harmonic were found more than 20dB below limit line.								
Frequency (MHz)	EIRP (dBm)	Limit (dBm)	Over Limit (dB)	SPA Reading (dBm)	S.G. Power (dBm)	TX Cable loss (dB)	TX Antenna Gain (dBi)	Polarization (H/V)	Result
3462	-48.18	-13	-35.18	-63.13	-52.01	4.48	8.31	V	Pass
5198	-26.78	-13	-13.78	-45.2	-31.42	5.332	9.98	V	Pass
6927	-31.78	-13	-18.78	-56.59	-37.02	6.1	11.34	V	Pass
8663	-37.83	-13	-24.83	-62.77	-42.75	8.25	13.17	V	Pass
10392	-40.27	-13	-27.27	-68.12	-44.56	8.65	12.94	V	Pass
12120	-35.96	-13	-22.96	-65.41	-40.27	8.59	12.90	V	Pass



Band :	LTE Band 4		Temperature :	21~24°C					
Test Mode :	3MHz QPSK RB Size 1 Offset 0		Relative Humidity :	44~48%					
Test Engineer :	Kai Wang, Stan Hsieh, and Ken Wu		Polarization :	Horizontal					
Remark :	Spurious emissions within 30-10th harmonic were found more than 20dB below limit line.								
Frequency (MHz)	EIRP (dBm)	Limit (dBm)	Over Limit (dB)	SPA Reading (dBm)	S.G. Power (dBm)	TX Cable loss (dB)	TX Antenna Gain (dBi)	Polarization (H/V)	Result
3469	-51.86	-13	-38.86	-65.38	-55.69	4.48	8.31	H	Pass
5198	-38.74	-13	-25.74	-57.17	-43.38	5.332	9.98	H	Pass
6927	-36.95	-13	-23.95	-62.52	-42.19	6.1	11.34	H	Pass
8663	-40.13	-13	-27.13	-65.49	-45.05	8.25	13.17	H	Pass
10392	-37.57	-13	-24.57	-66.74	-41.86	8.65	12.94	H	Pass

Band :	LTE Band 4		Temperature :	21~24°C					
Test Mode :	3MHz QPSK RB Size 1 Offset 0		Relative Humidity :	44~48%					
Test Engineer :	Kai Wang, Stan Hsieh, and Ken Wu		Polarization :	Vertical					
Remark :	Spurious emissions within 30-10th harmonic were found more than 20dB below limit line.								
Frequency (MHz)	EIRP (dBm)	Limit (dBm)	Over Limit (dB)	SPA Reading (dBm)	S.G. Power (dBm)	TX Cable loss (dB)	TX Antenna Gain (dBi)	Polarization (H/V)	Result
3469	-48.34	-13	-35.34	-63.51	-52.17	4.48	8.31	V	Pass
5198	-37.87	-13	-24.87	-56.32	-42.51	5.332	9.98	V	Pass
6927	-35.65	-13	-22.65	-60.88	-40.89	6.1	11.34	V	Pass
8663	-42.37	-13	-29.37	-67.21	-47.29	8.25	13.17	V	Pass
10392	-41.17	-13	-28.17	-69.1	-45.46	8.65	12.94	V	Pass



Band :	LTE Band 4						Temperature :	21~24°C	
Test Mode :	5MHz QPSK RB Size 1 Offset 0						Relative Humidity :	44~48%	
Test Engineer :	Kai Wang, Stan Hsieh, and Ken Wu						Polarization :	Horizontal	
Remark :	Spurious emissions within 30-10th harmonic were found more than 20dB below limit line.								
Frequency (MHz)	EIRP (dBm)	Limit (dBm)	Over Limit (dB)	SPA Reading (dBm)	S.G. Power (dBm)	TX Cable loss (dB)	TX Antenna Gain (dBi)	Polarization (H/V)	Result
3462	-52.24	-13	-39.24	-65.93	-56.07	4.48	8.31	H	Pass
5198	-41.61	-13	-28.61	-59.73	-46.25	5.332	9.98	H	Pass
6934	-37.34	-13	-24.34	-63.36	-42.58	6.1	11.34	H	Pass
8663	-41.10	-13	-28.10	-66.05	-46.02	8.25	13.17	H	Pass
10392	-38.90	-13	-25.90	-67.95	-43.19	8.65	12.94	H	Pass

Band :	LTE Band 4						Temperature :	21~24°C	
Test Mode :	5MHz QPSK RB Size 1 Offset 0						Relative Humidity :	44~48%	
Test Engineer :	Kai Wang, Stan Hsieh, and Ken Wu						Polarization :	Vertical	
Remark :	Spurious emissions within 30-10th harmonic were found more than 20dB below limit line.								
Frequency (MHz)	EIRP (dBm)	Limit (dBm)	Over Limit (dB)	SPA Reading (dBm)	S.G. Power (dBm)	TX Cable loss (dB)	TX Antenna Gain (dBi)	Polarization (H/V)	Result
3462	-49.43	-13	-36.43	-64.55	-53.26	4.48	8.31	V	Pass
5198	-42.11	-13	-29.11	-60.42	-46.75	5.332	9.98	V	Pass
6934	-35.87	-13	-22.87	-60.75	-41.11	6.1	11.34	V	Pass
8663	-42.24	-13	-29.24	-67.15	-47.16	8.25	13.17	V	Pass
10392	-40.98	-13	-27.98	-68.79	-45.27	8.65	12.94	V	Pass



Band :	LTE Band 4	Temperature :	21~24°C						
Test Mode :	10MHz QPSK RB Size 1 Offset 0	Relative Humidity :	44~48%						
Test Engineer :	Kai Wang, Stan Hsieh, and Ken Wu	Polarization :	Horizontal						
Remark :	Spurious emissions within 30-10th harmonic were found more than 20dB below limit line.								
Frequency (MHz)	EIRP (dBm)	Limit (dBm)	Over Limit (dB)	SPA Reading (dBm)	S.G. Power (dBm)	TX Cable loss (dB)	TX Antenna Gain (dBi)	Polarization (H/V)	Result
3455	-49.27	-13	-36.27	-64.35	-53.1	4.48	8.31	H	Pass
5184	-28.86	-13	-15.86	-48.01	-33.5	5.332	9.98	H	Pass
6913	-31.46	-13	-18.46	-57.42	-36.7	6.1	11.34	H	Pass
8642	-37.18	-13	-24.18	-63.15	-42.1	8.25	13.17	H	Pass
10368	-37.91	-13	-24.91	-67	-42.2	8.65	12.94	H	Pass

Band :	LTE Band 4	Temperature :	21~24°C						
Test Mode :	10MHz QPSK RB Size 1 Offset 0	Relative Humidity :	44~48%						
Test Engineer :	Kai Wang, Stan Hsieh, and Ken Wu	Polarization :	Vertical						
Remark :	Spurious emissions within 30-10th harmonic were found more than 20dB below limit line.								
Frequency (MHz)	EIRP (dBm)	Limit (dBm)	Over Limit (dB)	SPA Reading (dBm)	S.G. Power (dBm)	TX Cable loss (dB)	TX Antenna Gain (dBi)	Polarization (H/V)	Result
3455	-47.37	-13	-34.37	-63.41	-51.2	4.48	8.31	V	Pass
5184	-27.46	-13	-14.46	-46.13	-32.1	5.332	9.98	V	Pass
6913	-31.96	-13	-18.96	-57.52	-37.2	6.1	11.34	V	Pass
8642	-37.48	-13	-24.48	-62.61	-42.4	8.25	13.17	V	Pass
10368	-39.01	-13	-26.01	-67.19	-43.3	8.65	12.94	V	Pass



Band :	LTE Band 4	Temperature :	21~24°C						
Test Mode :	15MHz QPSK RB Size 1 Offset 0	Relative Humidity :	44~48%						
Test Engineer :	Kai Wang, Stan Hsieh, and Ken Wu	Polarization :	Horizontal						
Remark :	Spurious emissions within 30-10th harmonic were found more than 20dB below limit line.								
Frequency (MHz)	EIRP (dBm)	Limit (dBm)	Over Limit (dB)	SPA Reading (dBm)	S.G. Power (dBm)	TX Cable loss (dB)	TX Antenna Gain (dBi)	Polarization (H/V)	Result
3448	-49.77	-13	-36.77	-64.17	-53.6	4.48	8.31	H	Pass
5177	-27.66	-13	-14.66	-46.27	-32.3	5.332	9.98	H	Pass
6906	-29.76	-13	-16.76	-55.81	-35	6.1	11.34	H	Pass
8628	-37.28	-13	-24.28	-62.9	-42.2	8.25	13.17	H	Pass
10352	-35.81	-13	-22.81	-64.86	-40.1	8.65	12.94	H	Pass
12080	-34.79	-13	-21.79	-65.79	-39.1	8.59	12.90	H	Pass

Band :	LTE Band 4	Temperature :	21~24°C						
Test Mode :	15MHz QPSK RB Size 1 Offset 0	Relative Humidity :	44~48%						
Test Engineer :	Kai Wang, Stan Hsieh, and Ken Wu	Polarization :	Vertical						
Remark :	Spurious emissions within 30-10th harmonic were found more than 20dB below limit line.								
Frequency (MHz)	EIRP (dBm)	Limit (dBm)	Over Limit (dB)	SPA Reading (dBm)	S.G. Power (dBm)	TX Cable loss (dB)	TX Antenna Gain (dBi)	Polarization (H/V)	Result
3448	-47.07	-13	-34.07	-63.12	-50.9	4.48	8.31	V	Pass
5177	-27.16	-13	-14.16	-45.96	-31.8	5.332	9.98	V	Pass
6906	-30.26	-13	-17.26	-55.57	-35.5	6.1	11.34	V	Pass
8628	-36.98	-13	-23.98	-62.1	-41.9	8.25	13.17	V	Pass
10352	-41.31	-13	-28.31	-69.41	-45.6	8.65	12.94	V	Pass
12080	-34.39	-13	-21.39	-64.55	-38.7	8.59	12.90	V	Pass



Band :	LTE Band 4	Temperature :	21~24°C						
Test Mode :	20MHz QPSK RB Size 1 Offset 0	Relative Humidity :	44~48%						
Test Engineer :	Kai Wang, Stan Hsieh, and Ken Wu	Polarization :	Horizontal						
Remark :	Spurious emissions within 30-10th harmonic were found more than 20dB below limit line.								
Frequency (MHz)	EIRP (dBm)	Limit (dBm)	Over Limit (dB)	SPA Reading (dBm)	S.G. Power (dBm)	TX Cable loss (dB)	TX Antenna Gain (dBi)	Polarization (H/V)	Result
3462	-52.20	-13	-39.20	-66.12	-56.03	4.48	8.31	H	Pass
5198	-45.00	-13	-32.00	-63.62	-49.64	5.332	9.98	H	Pass
6927	-37.86	-13	-24.86	-63.7	-43.1	6.1	11.34	H	Pass
8663	-43.10	-13	-30.10	-68.56	-48.02	8.25	13.17	H	Pass

Band :	LTE Band 4	Temperature :	21~24°C						
Test Mode :	20MHz QPSK RB Size 1 Offset 0	Relative Humidity :	44~48%						
Test Engineer :	Kai Wang, Stan Hsieh, and Ken Wu	Polarization :	Vertical						
Remark :	Spurious emissions within 30-10th harmonic were found more than 20dB below limit line.								
Frequency (MHz)	EIRP (dBm)	Limit (dBm)	Over Limit (dB)	SPA Reading (dBm)	S.G. Power (dBm)	TX Cable loss (dB)	TX Antenna Gain (dBi)	Polarization (H/V)	Result
3462	-51.62	-13	-38.62	-66.73	-55.45	4.48	8.31	V	Pass
5198	-43.75	-13	-30.75	-62.44	-48.39	5.332	9.98	V	Pass
6927	-36.99	-13	-23.99	-61.52	-42.23	6.1	11.34	V	Pass
8663	-44.08	-13	-31.08	-69.1	-49	8.25	13.17	V	Pass



Band :	LTE Band 7					Temperature :	21~24°C		
Test Mode :	5MHz QPSK RB Size 1 Offset 0					Relative Humidity :	44~48%		
Test Engineer :	Kai Wang, Stan Hsieh, and Ken Wu					Polarization :	Horizontal		
Remark :	Spurious emissions within 30-10th harmonic were found more than 20dB below limit line.								
Frequency (MHz)	EIRP (dBm)	Limit (dBm)	Over Limit (dB)	SPA Reading (dBm)	S.G. Power (dBm)	TX Cable loss (dB)	TX Antenna Gain (dBi)	Polarization (H/V)	Result
5064	-42.71	-25	-17.71	-61.11	-46.2	6.86	10.35	H	Pass
7596	-35.71	-25	-10.71	-62.69	-38.6	9.34	12.23	H	Pass
10128	-34.00	-25	-9.00	-63.1	-38.1	8.64	12.74	H	Pass

Band :	LTE Band 7					Temperature :	21~24°C		
Test Mode :	5MHz QPSK RB Size 1 Offset 0					Relative Humidity :	44~48%		
Test Engineer :	Kai Wang, Stan Hsieh, and Ken Wu					Polarization :	Vertical		
Remark :	Spurious emissions within 30-10th harmonic were found more than 20dB below limit line.								
Frequency (MHz)	EIRP (dBm)	Limit (dBm)	Over Limit (dB)	SPA Reading (dBm)	S.G. Power (dBm)	TX Cable loss (dB)	TX Antenna Gain (dBi)	Polarization (H/V)	Result
5064	-39.81	-25	-14.81	-58.4	-43.3	6.86	10.35	V	Pass
7596	-38.01	-25	-13.01	-64.7	-40.9	9.34	12.23	V	Pass
10128	-32.60	-25	-7.60	-60.58	-36.7	8.64	12.74	V	Pass



Band :	LTE Band 7	Temperature :	21~24°C						
Test Mode :	10MHz QPSK RB Size 1 Offset 0	Relative Humidity :	44~48%						
Test Engineer :	Kai Wang, Stan Hsieh, and Ken Wu	Polarization :	Horizontal						
Remark :	Spurious emissions within 30-10th harmonic were found more than 20dB below limit line.								
Frequency (MHz)	EIRP (dBm)	Limit (dBm)	Over Limit (dB)	SPA Reading (dBm)	S.G. Power (dBm)	TX Cable loss (dB)	TX Antenna Gain (dBi)	Polarization (H/V)	Result
5058	-43.41	-25	-18.41	-62	-46.9	6.86	10.35	H	Pass
7590	-32.31	-25	-7.31	-59.14	-35.2	9.34	12.23	H	Pass
10122	-36.00	-25	-11.00	-65.1	-40.1	8.64	12.74	H	Pass
12654	-37.74	-25	-12.74	-71.04	-42	8.99	13.25	H	Pass

Band :	LTE Band 7	Temperature :	21~24°C						
Test Mode :	10MHz QPSK RB Size 1 Offset 0	Relative Humidity :	44~48%						
Test Engineer :	Kai Wang, Stan Hsieh, and Ken Wu	Polarization :	Vertical						
Remark :	Spurious emissions within 30-10th harmonic were found more than 20dB below limit line.								
Frequency (MHz)	EIRP (dBm)	Limit (dBm)	Over Limit (dB)	SPA Reading (dBm)	S.G. Power (dBm)	TX Cable loss (dB)	TX Antenna Gain (dBi)	Polarization (H/V)	Result
5098	-40.01	-25	-15.01	-58.46	-43.5	6.86	10.35	V	Pass
7590	-36.81	-25	-11.81	-63.55	-39.7	9.34	12.23	V	Pass
10122	-32.20	-25	-7.20	-60.24	-36.3	8.64	12.74	V	Pass
12654	-36.84	-25	-11.84	-68.12	-41.1	8.99	13.25	V	Pass



Band :	LTE Band 7	Temperature :	21~24°C						
Test Mode :	15MHz QPSK RB Size 1 Offset 0	Relative Humidity :	44~48%						
Test Engineer :	Kai Wang, Stan Hsieh, and Ken Wu	Polarization :	Horizontal						
Remark :	Spurious emissions within 30-10th harmonic were found more than 20dB below limit line.								
Frequency (MHz)	EIRP (dBm)	Limit (dBm)	Over Limit (dB)	SPA Reading (dBm)	S.G. Power (dBm)	TX Cable loss (dB)	TX Antenna Gain (dBi)	Polarization (H/V)	Result
5058	-43.31	-25	-18.31	-61.66	-46.8	6.86	10.35	H	Pass
7584	-32.81	-25	-7.81	-59.98	-35.7	9.34	12.23	H	Pass
10110	-32.10	-25	-7.10	-61.01	-36.2	8.64	12.74	H	Pass
12642	-37.84	-25	-12.84	-70.85	-42.1	8.99	13.25	H	Pass

Band :	LTE Band 7	Temperature :	21~24°C						
Test Mode :	15MHz QPSK RB Size 1 Offset 0	Relative Humidity :	44~48%						
Test Engineer :	Kai Wang, Stan Hsieh, and Ken Wu	Polarization :	Vertical						
Remark :	Spurious emissions within 30-10th harmonic were found more than 20dB below limit line.								
Frequency (MHz)	EIRP (dBm)	Limit (dBm)	Over Limit (dB)	SPA Reading (dBm)	S.G. Power (dBm)	TX Cable loss (dB)	TX Antenna Gain (dBi)	Polarization (H/V)	Result
5058	-40.21	-25	-15.21	-58.96	-43.7	6.86	10.35	V	Pass
7584	-37.21	-25	-12.21	-63.96	-40.1	9.34	12.23	V	Pass
10110	-31.60	-25	-6.60	-57.62	-35.7	8.64	12.74	V	Pass
12642	-36.84	-25	-11.84	-67.55	-41.1	8.99	13.25	V	Pass



Band :	LTE Band 7	Temperature :	21~24°C						
Test Mode :	20MHz QPSK RB Size 1 Offset 0	Relative Humidity :	44~48%						
Test Engineer :	Kai Wang, Stan Hsieh, and Ken Wu	Polarization :	Horizontal						
Remark :	Spurious emissions within 30-10th harmonic were found more than 20dB below limit line.								
Frequency (MHz)	EIRP (dBm)	Limit (dBm)	Over Limit (dB)	SPA Reading (dBm)	S.G. Power (dBm)	TX Cable loss (dB)	TX Antenna Gain (dBi)	Polarization (H/V)	Result
5052	-39.01	-25	-14.01	-57.23	-42.5	6.86	10.35	H	Pass
7578	-33.41	-25	-8.41	-60.71	-36.3	9.34	12.23	H	Pass
10104	-32.10	-25	-7.10	-61.18	-36.2	8.64	12.74	H	Pass
12630	-36.94	-25	-11.94	-70.28	-41.2	8.99	13.25	H	Pass

Band :	LTE Band 7	Temperature :	21~24°C						
Test Mode :	20MHz QPSK RB Size 1 Offset 0	Relative Humidity :	44~48%						
Test Engineer :	Kai Wang, Stan Hsieh, and Ken Wu	Polarization :	Vertical						
Remark :	Spurious emissions within 30-10th harmonic were found more than 20dB below limit line.								
Frequency (MHz)	EIRP (dBm)	Limit (dBm)	Over Limit (dB)	SPA Reading (dBm)	S.G. Power (dBm)	TX Cable loss (dB)	TX Antenna Gain (dBi)	Polarization (H/V)	Result
5052	-37.71	-25	-12.71	-56.14	-41.2	6.86	10.35	V	Pass
7578	-35.41	-25	-10.41	-62.56	-38.3	9.34	12.23	V	Pass
10104	-32.00	-25	-7.00	-58.81	-36.1	8.64	12.74	V	Pass
12630	-35.84	-25	-10.84	-66.92	-40.1	8.99	13.25	V	Pass

3.8 Frequency Stability Measurement

3.8.1 Description of Frequency Stability Measurement

The frequency stability shall be measured by variation of ambient temperature and variation of primary supply voltage to ensure that the fundamental emission stays within the authorized frequency block. The frequency stability of the transmitter shall be maintained within $\pm 0.00025\%$ ($\pm 2.5\text{ppm}$) of the center frequency.

3.8.2 Measuring Instruments

The measuring equipment is listed in the section 4 of this test report.

3.8.3 Test Procedures for Temperature Variation

1. The EUT was set up in the thermal chamber and connected with the system simulator.
2. With power OFF, the temperature was decreased to -30°C and the EUT was stabilized before testing. Power was applied and the maximum change in frequency was recorded within one minute.
3. With power OFF, the temperature was raised in 10°C step up to 50°C . The EUT was stabilized at each step for at least half an hour. Power was applied and the maximum frequency change was recorded within one minute.

3.8.4 Test Procedures for Voltage Variation

1. The EUT was placed in a temperature chamber at $25\pm 5^{\circ}\text{C}$ and connected with the system simulator.
2. The power supply voltage to the EUT was varied from 85% to 115% of the nominal value measured at the input to the EUT.
3. The variation in frequency was measured for the worst case.

3.8.5 Test Setup

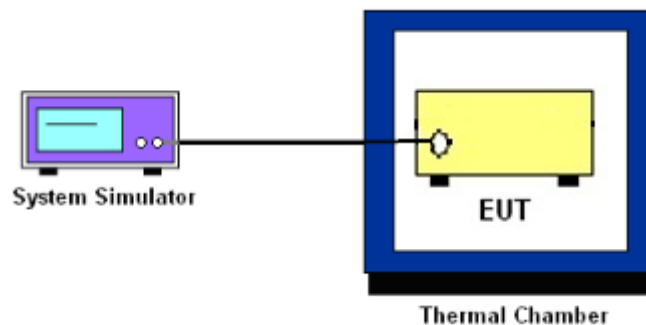



3.8.6 Test Result of Temperature Variation

Band :	LTE Band 4 (QPSK)	Limit (ppm) :	2.5
Temperature (°C)	BW 10MHz		Result
	Deviation (ppm)		
50	0.0109		PASS
40	0.0001		
30	0.0005		
20(Ref.)	0.0000		
10	0.0102		
0	0.0002		
-10	0.0011		
-20	0.0114		
-30	0.0005		

Band :	LTE Band 7 (QPSK)	Limit (ppm) :	2.5
Temperature (°C)	BW 10MHz		Result
	Deviation (ppm)		
50	0.0005		PASS
40	0.0088		
30	0.0097		
20(Ref.)	0.0000		
10	0.0002		
0	0.0006		
-10	0.0093		
-20	0.0090		
-30	0.0001		



3.8.7 Test Result of Voltage Variation

Band	Bandwidth	Voltage (Volt)	Deviation (ppm)	Limit (ppm)	Result
LTE Band 4	10M	4.20	0.0000	2.5	PASS
		Normal	0.0006		
		3.60	0.0103		
LTE Band 7	10M	4.20	0.0003	2.5	PASS
		Normal	0.0004		
		3.60	0.0092		

Remark:

1. Normal Voltage = 3.70V.
2. The manufacturer declared that the EUT could work properly between voltage 3.60V ~ 4.20V.



4 List of Measuring Equipment

Instrument	Manufacturer	Model No.	Serial No.	Characteristics	Calibration Date	Test Date	Due Date	Remark
Spectrum Analyzer	Rohde & Schwarz	FSP40	100055	9kHz~40GHz	Jun. 07, 2013	Jun. 03, 2014~ Jun. 05, 2014	Jun. 06, 2014	Conducted (TH02-HY)
Spectrum Analyzer	Rohde & Schwarz	FSP40	100055	9kHz~40GHz	Jun. 09, 2014	Jun. 09, 2014~ Jun. 23, 2014	Jun. 08, 2015	Conducted (TH02-HY)
Thermal Chamber	Ten Billion	TTH-D3SP	TBN-9307 01	N/A	Jul. 19, 2013	Jun. 03, 2014~ Jun. 23, 2014	Jul. 18, 2014	Conducted (TH02-HY)
LTE Base Station	Anritsu	MT8820C	620102648 0	30MHz~2.7GHz SISO (FDD Band 1~26)	Jan. 07, 2014	Jun. 03, 2014~ Jun. 23, 2014	Jan. 06, 2015	Conducted (TH02-HY)
Spectrum Analyzer	Rohde & Schwarz	FSV30	101749	10Hz ~ 30GHz	Feb. 10, 2014	Jun. 16, 2014~ Jun. 25, 2014	Feb. 09, 2015	Radiation (03CH07-HY)
Bilog Antenna	Schaffner	CBL6111C	2726	30MHz ~ 1GHz	Oct. 10, 2013	Jun. 16, 2014~ Jun. 25, 2014	Oct. 09, 2014	Radiation (03CH07-HY)
Double Ridge Horn Antenna	ESCO	3117	75962	1GHz~18GHz	Aug. 22, 2013	Jun. 16, 2014~ Jun. 25, 2014	Aug. 21, 2014	Radiation (03CH07-HY)
Preamplifier	COM-POWER	PA-103A	161241	10 MHz ~ 1000MHz 32dB GAIN	Mar. 17, 2014	Jun. 16, 2014~ Jun. 25, 2014	Mar. 16, 2015	Radiation (03CH07-HY)
Preamplifier	Agilent	8449B	3008A023 62	1 GHz~26.5 GHz	Nov. 29, 2013	Jun. 16, 2014~ Jun. 25, 2014	Nov. 28, 2014	Radiation (03CH07-HY)
Turn Table	ChainTek	ChainTek 3000	N/A	0 ~ 360 degree	N/A	Jun. 16, 2014~ Jun. 25, 2014	N/A	Radiation (03CH07-HY)
Antenna Mast	ChainTek	M-400-0	114/80006 04/L	N/A	N/A	Jun. 16, 2014~ Jun. 25, 2014	N/A	Radiation (03CH07-HY)
SHF-EHF Horn Antenna	SCHWARZBE CK	BBHA 9170	BBHA9170 251	15GHz- 40GHz	Oct. 03, 2013	Jun. 16, 2014~ Jun. 25, 2014	Oct. 02, 2014	Radiation (03CH07-HY)



5 Uncertainty of Evaluation

Uncertainty of Radiated Emission Measurement (30 MHz ~ 1000 MHz)

Measuring Uncertainty for a Level of Confidence of 95% ($U = 2Uc(y)$)	4.50
---	------