

TEST REPORT

of

FCC Part 22 Subpart H, Part 24 Subpart E and Part 27 Subpart C
FCC ID: ZNFV32

Equipment Under Test : Cellular/PCS GSM/GPRS/EDGE/WCDMA and LTE phone with Bluetooth, WLAN and RFID
Model Name : LGV32
Applicant : LG Electronics MobileComm U.S.A., Inc.
Manufacturer : LG Electronics MobileComm U.S.A., Inc.
Date of Test(s) : 2015.03.05 ~ 2015.04.05
Date of Issue : 2015.04.13

In the configuration tested, the EUT complied with the standards specified above.

Tested By:



Jungmin Yang

Date:

2015.04.13

Approved By:



Hyunchoe You

Date:

2015.04.13

The results shown in this test report refer only to the sample(s) tested unless otherwise stated. This test report cannot be reproduced, except in full, without prior written permission of the Company.

INDEX

<u>TABLE OF CONTENTS</u>	Page
1. General Information -----	3
2. RF radiated output power & spurious radiated emission -----	6
3. Occupied Bandwidth 99 % -----	45
4. Peak-Average Ratio -----	98
5. Spurious Emissions At Antenna Terminal -----	102
6. Band Edge -----	159
7. Frequency Stability -----	183

The results shown in this test report refer only to the sample(s) tested unless otherwise stated. This test report cannot be reproduced, except in full, without prior written permission of the Company.

1. General information

1.1. Testing laboratory

SGS Korea Co., Ltd. (Gunpo Laboratory)

- Wireless Div. 2FL, 10-2, LS-ro 182beon-gil, Gunpo-si, Gyeonggi-do, Korea, 435-837

All SGS services are rendered in accordance with the applicable SGS conditions of service available on request and accessible at <http://www.sgs.com/en/Terms-and-Conditions.aspx>.

Telephone : +82 31 688 0901

FAX : +82 31 688 0921

1.2. Details of applicant

Applicant : LG Electronics MobileComm U.S.A., Inc.

Address : 10101 Old Grove Road, San Diego, CA 92131

Contact Person : An, Hee-Ju

Phone No. : +82 2 2033 1103

1.3. Description of EUT

Kind of Product	Cellular/PCS GSM/GPRS/EDGE/WCDMA and LTE phone with Bluetooth, WLAN and RFID
Model Name	LGV32
Power Supply	DC 3.85 V
Rated Power	GSM850: 32.7 dB m GSM1900: 29.7 dB m WCDMA850: 23.9 dB m LTE Band 5, 17, 41: 23.2 dB m
Frequency Range	GSM850: 824.2 MHz ~ 848.8 MHz GSM1900: 1 850.2 MHz ~ 1 909.8 MHz WCDMA850: 826.4 MHz ~ 846.6 MHz LTE Band 5 (1.4 MHz): 824.7 MHz ~ 848.3 MHz, LTE Band 5 (3 MHz): 825.5 MHz ~ 847.5 MHz LTE Band 5 (5 MHz): 826.5 MHz ~ 846.5 MHz, LTE Band 5 (10 MHz): 829.0 MHz ~ 844.0 MHz LTE Band 17 (5 MHz): 706.5 MHz ~ 713.5 MHz, LTE Band 17 (10 MHz): 709.0 MHz ~ 711.0 MHz LTE Band 41 (5 MHz): 2 498.5 MHz ~ 2 687.5 MHz, LTE Band 41 (10 MHz): 2 501.0 MHz ~ 2 685.0 MHz LTE Band 41 (15 MHz): 2 503.5 MHz ~ 2 682.5 MHz, LTE Band 41 (20 MHz): 2 506.0 MHz ~ 2 680.0 MHz
Class of GPRS	Class 12, Class B
Emission Designator	GSM850: 248KGXW (GPRS) / 254KG7W (EDGE) GSM1900: 247KGXW (GPRS) / 245KG7W (EDGE) WCDMA850: 4M15F9W LTE Band 5 (1.4 MHz): 1M10G7D (QPSK) / 1M10W7D (16QAM) LTE Band 5 (3 MHz): 2M71G7D (QPSK) / 2M70W7D (16QAM) LTE Band 5 (5 MHz): 4M51G7D (QPSK) / 4M51W7D (16QAM) LTE Band 5 (10 MHz): 8M96G7D (QPSK) / 8M98W7D (16QAM) LTE Band 17 (5 MHz): 4M51G7D (QPSK) / 4M51W7D (16QAM) LTE Band 17 (10 MHz): 8M97G7D (QPSK) / 8M96W7D (16QAM) LTE Band 41 (5 MHz): 4M52G7D (QPSK) / 4M51W7D (16QAM) LTE Band 41 (10 MHz): 8M95G7D (QPSK) / 8M95W7D (16QAM) LTE Band 41 (15 MHz): 13M4G7D (QPSK) / 13M5W7D (16QAM) LTE Band 41 (20 MHz): 17M9G7D (QPSK) / 17M9W7D (16QAM)
H/W Version	REV.A
S/W Version	HDB08o

The results shown in this test report refer only to the sample(s) tested unless otherwise stated. This test report cannot be reproduced, except in full, without prior written permission of the Company.

1.4. Test equipment list

Equipment	Manufacturer	Model	S/N	Cal. Date	Cal. Interval	Cal. Due.
Signal Generator	Agilent	E8257D	MY51501169	Jul. 17, 2014	Annual	Jul. 17, 2015
Spectrum Analyzer	Agilent	N9030A	US51350132	Sep. 24, 2014	Annual	Sep. 24, 2015
Spectrum Analyzer	R&S	FSV30	103210	Dec. 29, 2014	Annual	Dec. 29, 2015
Mobile Test Unit	R&S	CMW500	144035	Mar. 03, 2015	Annual	Mar. 03, 2016
Mobile Test Unit	R&S	CMW500	144032	Mar. 09, 2015	Annual	Mar. 09, 2016
Directional Coupler	KRYTAR	152613	122660	Jun. 10, 2014	Annual	Jun. 10, 2015
Temperature Chamber	ESPEC CORP.	PL-1J	15000793	Jun. 25, 2014	Annual	Jun. 25, 2015
High Pass Filter	Mini-Circuits	NHP-800	V8207600724	Mar. 24, 2015	Annual	Mar. 24, 2016
High Pass Filter	Wainwright	WHK3.0/18G-6SS	4	Jul. 02, 2014	Annual	Jul. 02, 2015
High Pass Filter	Wainwright	WHK1.5/15G-6SS	4	Mar. 13, 2015	Annual	Mar. 13, 2016
High Pass Filter	Wainwright	WHK7.5/26.5G-6SS	15	Jul. 02, 2014	Annual	Jul. 02, 2015
DC Power Supply	Agilent	U8002A	MY48490027	Dec. 22, 2014	Annual	Dec. 22, 2015
Preamplifier	H.P.	8447F	2944A03909	Aug. 27, 2014	Annual	Aug. 27, 2015
Preamplifier	R&S	SCU 18	10117	Dec. 26, 2014	Annual	Dec. 26, 2015
Preamplifier	MITEQ Inc.	JS44-18004000-35-8P	1546891	Apr. 28, 2014	Annual	Apr. 28, 2015
Test Receiver	R&S	ESU26	100109	Mar. 03, 2015	Annual	Mar. 03, 2016
Bilog Antenna	SCHWARZBECK	VULB9163	396	Jun. 07, 2013	Biennial	Jun. 07, 2015
Horn Antenna	SCHWARZBECK	BBHA9170	BBHA9170431	May 15, 2014	Biennial	May 15, 2016
Horn Antenna	R&S	HF906	100326	Dec. 10, 2013	Biennial	Dec. 10, 2015
Dipole Antenna	SCHWARZBECK MESSELEKTRONIK	VHA 9103	9103-2817	May 09, 2013	Biennial	May 09, 2015
Dipole Antenna	SCHWARZBECK MESSELEKTRONIK	UHA 9105	9105-2514	May 09, 2013	Biennial	May 09, 2015
Antenna Master	INNCO	MM4000	N/A	N.C.R.	N/A	N.C.R.
Turn Table	INNCO	DS 1200S	N/A	N.C.R.	N/A	N.C.R.
Anechoic Chamber	SY Corporation	L x W x H (9.6 m x 6.4 m x 6.4 m)	N/A	N.C.R.	N/A	N.C.R.

► Support equipment

Description	Manufacturer	Model	Serial Number
N/A	-	-	-

The results shown in this test report refer only to the sample(s) tested unless otherwise stated. This test report cannot be reproduced, except in full, without prior written permission of the Company.

1.5. Summary of test results

The EUT has been tested according to the following specifications:

APPLIED STANDARD: FCC Part 22, 24 and 27		
Section in FCC part	Test Item	Result
§22.913(a)(2) §24.232(c) §27.50(c)(10) §27.50(h)(2)	RF Radiated Output Power	Complied
§2.1053 §22.917(a) §24.238(a) §27.53(g) §27.53(m)	Spurious Radiated Emission	Complied
§2.1046	Conducted Output Power	See SAR Report
§2.1049	Occupied Bandwidth	Complied
§24.232(d)	Peak-Average Ratio	Complied
§2.1051 §22.917(a) §24.238(a) §27.53(g) §27.53(m)	Spurious Emission at Antenna Terminal	Complied
§22.917(a) §24.238(a) §27.53(g) §27.53(m)	Band Edge	Complied
§2.1055 §22.355 §24.235 §27.54	Frequency Stability	Complied

1.6. Test report revision

Revision	Report number	Date of Issue	Description
0	F690501/RF-RTL008571	2015.04.07	Initial
1	F690501/RF-RTL008571-1	2015.04.13	Add 99 % BW plots of Edge850,1900

1.7. Sample calculation for offset

Where relevant, the following sample calculation is provided:

1.7.1. Conducted test

Offset value (dB) = Directional Coupler (dB) + Cable loss (dB)

1.7.2. Radiation test

E.R.P. & E.I.R.P. = [S.G level + Amp.](dB m) - Cable loss(dB) + Ant. gain (dB d/dB i)

The results shown in this test report refer only to the sample(s) tested unless otherwise stated. This test report cannot be reproduced, except in full, without prior written permission of the Company.

2. RF radiated output power & spurious radiated emission

2.1. Test setup

The diagram below shows the test setup that is utilized to make the measurements for emission from 30 MHz to 1 GHz Emissions.

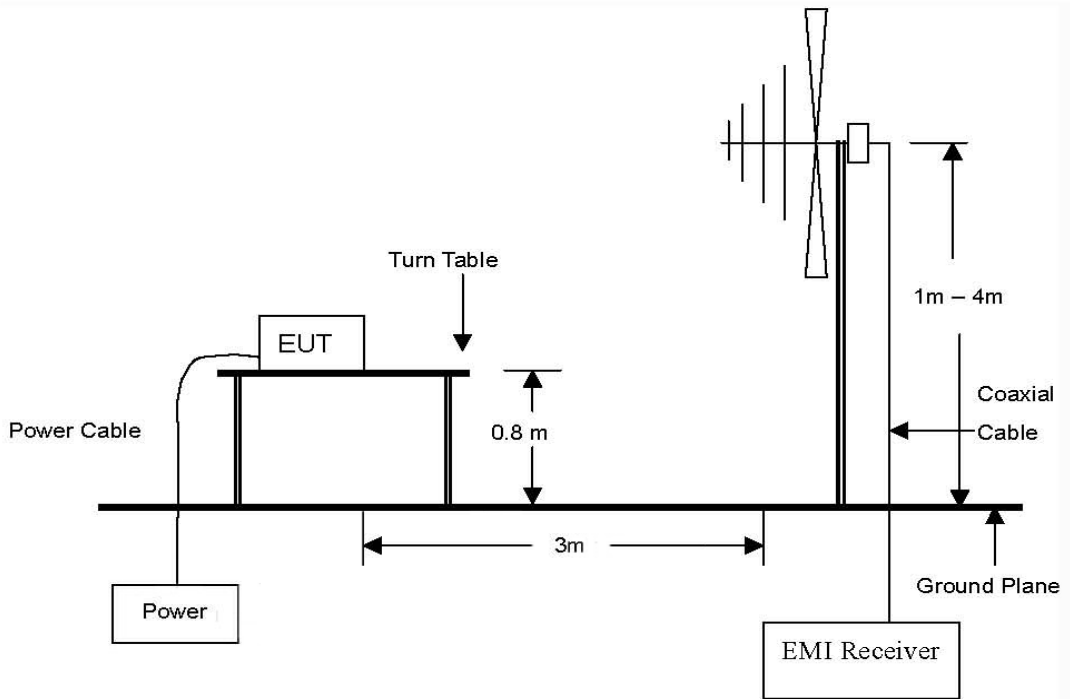

The diagram below shows the test setup that is utilized to make the measurements for emission from 1 GHz to 20 GHz Emissions.

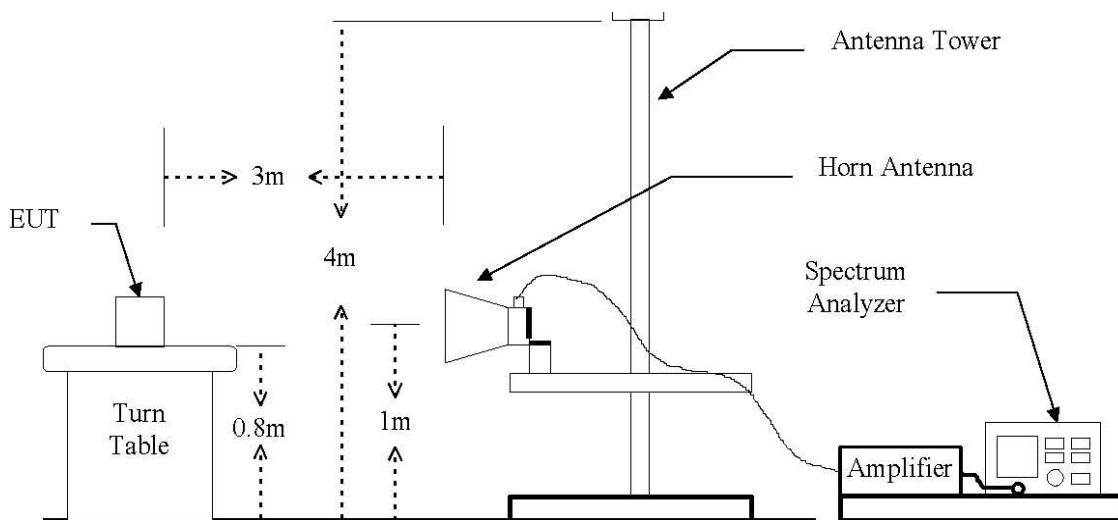

The results shown in this test report refer only to the sample(s) tested unless otherwise stated. This test report cannot be reproduced, except in full, without prior written permission of the Company.

The diagram below shows the test setup for substituted method.

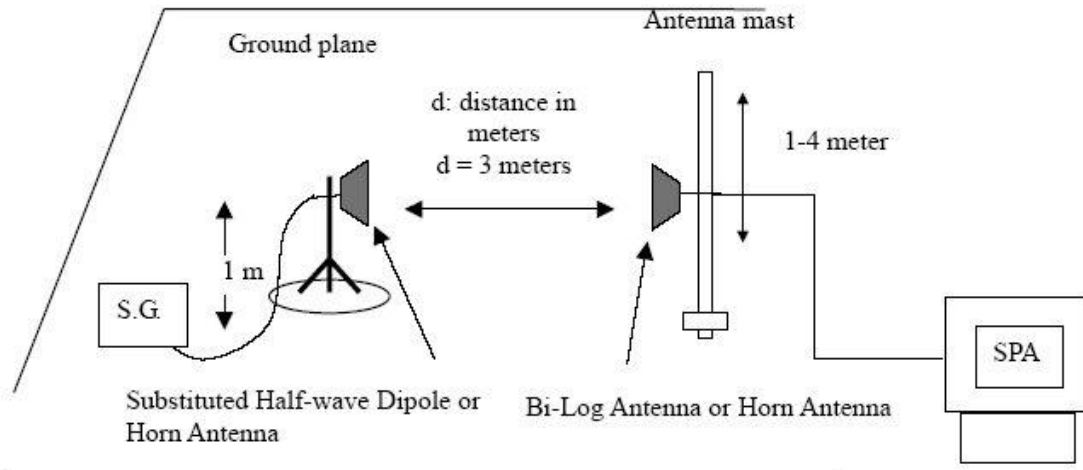

The results shown in this test report refer only to the sample(s) tested unless otherwise stated. This test report cannot be reproduced, except in full, without prior written permission of the Company.

2.2. Limit

2.2.1. Limit of radiated output power

FCC §22.913(a)(2), The ERP of mobile transmitters and auxiliary test transmitters must not exceed 7 watts.

FCC §24.232(c), Mobile and portable stations are limited to 2 watts e.i.r.p. peak power and the equipment must employ means to limit the power to the minimum necessary for successful communications.

FCC §27.50(c)(10), Portable stations (hand-held devices) in the 600 MHz uplink band and the 698-746 MHz band, and fixed and mobile stations in the 600 MHz uplink band are limited to 3 watts ERP.

FCC §27.50(h)(2), *Mobile and other user stations*. Mobile stations are limited to 2.0 watts EIRP. All user stations are limited to 2.0 watts transmitter output power.

2.2.2. Limit of spurious radiated emission

FCC §22.917(a), the power of any emission outside of the authorized operating frequency ranges must be attenuated below the transmitting power (P) by a factor of at least $43 + 10\log(P)$ dB.

FCC §24.238(a), the power of any emission outside of the authorized operating frequency ranges must be attenuated below the transmitting power (P) by a factor of at least $43 + 10 \log(P)$ dB.

FCC §27.53(g), For operations in the 600 MHz band and the 698-746 MHz band, the power of any emission outside a licensee's frequency band(s) of operation shall be attenuated below the transmitter power (P) within the licensed band(s) of operation, measured in watts, by at least $43 + 10 \log (P)$ dB.

FCC §27.53(m)(4), For mobile digital stations, the attenuation factor shall be not less than $40 + 10 \log (P)$ dB on all frequencies between the channel edge and 5 megahertz from the channel edge, $43 + 10 \log (P)$ dB on all frequencies between 5 megahertz and X megahertz from the channel edge, and $55 + 10 \log (P)$ dB on all frequencies more than X megahertz from the channel edge, where X is the greater of 6 megahertz or the actual emission bandwidth as defined in paragraph (m)(6) of this section. In addition, the attenuation factor shall not be less than $43 + 10 \log (P)$ dB on all frequencies between 2 490.5 MHz and 2 496 MHz and $55 + 10 \log (P)$ dB at or below 2 490.5 MHz. Mobile Satellite Service licensees operating on frequencies below 2 495 MHz may also submit a documented interference complaint against BRS licensees operating on channel BRS Channel 1 on the same terms and conditions as adjacent channel BRS or EBS licensees.

The results shown in this test report refer only to the sample(s) tested unless otherwise stated. This test report cannot be reproduced, except in full, without prior written permission of the Company.

2.3. Test procedure: Based on ANSI/TIA 603C: 2004

1. On a test site, the EUT shall be placed at 80cm height on a turn table, and in the position close to normal use as declared by the applicant.
2. The test antenna shall be oriented initially for vertical polarization located 3 m from EUT to correspond to the fundamental frequency of the transmitter.
3. The output of the test antenna shall be connected to the measuring receiver and the peak detector is used for the measurement.
4. The maximized power level is recorded using the spectrum analyzer "Channel Power" function with the integration band set to the emissions occupied bandwidth, RBW = 1-5 % of the OBW (not to exceed 1 MHz), VBW $\geq 3 \times$ RBW, Detector = RMS, sweep time = auto, trace average at least 100 traces in power averaging(i.e., RMS) mode, per the guidelines of KDB 971168 v02r02.
5. Radiated spurious emissions measurement method was set as follows:
RBW = 100 kHz for emissions below 1 GHz and 1 MHz for emissions above 1 GHz, VBW $\geq 3 \times$ RBW, Detector = Peak, trace mode = max hold, per the guidelines of KDB 971168 v02r02.
6. The transmitter shall be switched on, the measuring receiver shall be tuned to the frequency of the transmitter under test.
7. The test antenna shall be raised and lowered through the specified range of height until the maximum signal level is detected by the measuring receiver.
8. The transmitter shall be rotated through 360° in the horizontal plane, until the maximum signal level is detected by the measuring receiver.
9. The test antenna shall be raised and lowered again through the specified range of height until the maximum signal level is detected by the measuring receiver.
10. The maximum signal level detected by the measuring receiver shall be noted.
11. The EUT was replaced by half-wave dipole (1 GHz below) or horn antenna (1 GHz above) connected to a signal generator.
12. In necessary, the input attenuator setting on the measuring receiver shall be adjusted in order to increase the sensitivity of the measuring receiver.
13. The test antenna shall be raised and lowered through the specified range of height to ensure that the maximum signal is received.
14. The input signal to the substitution antenna shall be adjusted to the level that produces a level detected by the measuring receiver, which is equal to the level noted while the transmitter radiated power was measured, corrected for the change of input attenuator setting of the measuring receiver.
15. The input level to the substitution antenna shall be recorded as power level in dB m, corrected for any change of input attenuator setting of the measuring receiver.
16. The measurement shall be repeated with the test antenna and the substitution antenna orientated for horizontal polarization.

The results shown in this test report refer only to the sample(s) tested unless otherwise stated. This test report cannot be reproduced, except in full, without prior written permission of the Company.

2.4. Test result for RF radiated output power

Ambient temperature : (24 ± 1) °C
 Relative humidity : 47 % R.H.

GSM850

Frequency (MHz)	Ant. Pol. (H/V)	S.G level + Amp. (dB m)	Cable loss (dB)	Ant. gain (dB d)	E.R.P.	
					(dB m)	(mW)
824.2	V	28.14	3.28	-0.95	23.91	246.04
824.2	H	29.18	3.28	-0.95	24.95	312.61
836.6	V	27.33	3.31	-0.95	23.07	202.77
836.6	H	28.01	3.31	-0.95	23.75	237.14
848.8	V	26.84	3.35	-0.94	22.55	179.89
848.8	H	30.39	3.35	-0.94	26.10	407.38

GSM850 EDGE

Frequency (MHz)	Ant. Pol. (H/V)	S.G level + Amp. (dB m)	Cable loss (dB)	Ant. gain (dB d)	E.R.P.	
					(dB m)	(mW)
848.8	V	21.73	3.35	-0.94	17.44	55.46
848.8	H	24.02	3.35	-0.94	19.73	93.97

GSM1900

Frequency (MHz)	Ant. Pol. (H/V)	S.G level + Amp. (dB m)	Cable loss (dB)	Ant. gain (dB i)	E.I.R.P.	
					(dB m)	(mW)
1 850.2	V	15.06	5.90	7.88	17.04	50.58
1 850.2	H	21.40	5.90	7.88	23.38	217.77
1 880.0	V	15.90	5.83	7.86	17.93	62.09
1 880.0	H	23.70	5.83	7.86	25.73	374.11
1 909.8	V	16.92	5.77	7.84	18.99	79.25
1 909.8	H	24.62	5.77	7.84	26.69	466.66

GSM1900 EDGE

Frequency (MHz)	Ant. Pol. (H/V)	S.G level + Amp. (dB m)	Cable loss (dB)	Ant. gain (dB i)	E.I.R.P.	
					(dB m)	(mW)
1 909.8	V	11.19	5.90	7.88	13.17	20.75
1 909.8	H	17.71	5.77	7.84	19.78	95.06

The results shown in this test report refer only to the sample(s) tested unless otherwise stated. This test report cannot be reproduced, except in full, without prior written permission of the Company.

WCDMA850

Frequency (MHz)	Ant. Pol. (H/V)	S.G level + Amp. (dB m)	Cable loss (dB)	Ant. gain (dB d)	E.R.P.	
					(dB m)	(mW)
826.4	V	27.94	3.28	-0.95	23.71	234.96
826.4	H	28.65	3.28	-0.95	24.42	276.69
836.6	V	26.95	3.31	-0.95	22.69	185.78
836.6	H	28.79	3.31	-0.95	24.53	283.79
846.6	V	26.64	3.34	-0.94	22.36	172.19
846.6	H	30.61	3.34	-0.94	26.33	429.54

The results shown in this test report refer only to the sample(s) tested unless otherwise stated. This test report cannot be reproduced, except in full, without prior written permission of the Company.

LTE band 5 (1.4 MHz – QPSK)

Frequency (MHz)	Ant. Pol. (H/V)	S.G level + Amp. (dB m)	Cable loss (dB)	Ant. gain (dB d)	E.R.P.	
					(dB m)	(mW)
824.7	V	27.65	3.28	-0.95	23.42	219.79
824.7	H	27.45	3.28	-0.95	23.22	209.89
836.5	V	27.19	3.31	-0.95	22.93	196.34
836.5	H	26.67	3.31	-0.95	22.41	174.18
848.3	V	26.63	3.35	-0.94	22.34	171.40
848.3	H	30.09	3.35	-0.94	25.80	380.19

* 1.4 BW 1RB size / 0 Offset for B5

LTE band 5 (1.4 MHz – 16QAM)

Frequency (MHz)	Ant. Pol. (H/V)	S.G level + Amp. (dB m)	Cable loss (dB)	Ant. gain (dB d)	E.R.P.	
					(dB m)	(mW)
824.7	V	26.77	3.28	-0.95	22.54	179.47
824.7	H	26.27	3.28	-0.95	22.04	159.96
836.5	V	26.21	3.31	-0.95	21.95	156.68
836.5	H	25.78	3.31	-0.95	21.52	141.91
848.3	V	25.75	3.35	-0.94	21.46	139.96
848.3	H	28.75	3.35	-0.94	24.46	279.25

* 1.4 BW 1RB size / 0 Offset for B5

LTE band 5 (3 MHz – QPSK)

Frequency (MHz)	Ant. Pol. (H/V)	S.G level + Amp. (dB m)	Cable loss (dB)	Ant. gain (dB d)	E.R.P.	
					(dB m)	(mW)
825.5	V	27.56	3.28	-0.95	23.33	215.28
825.5	H	27.73	3.28	-0.95	23.50	223.87
836.5	V	27.07	3.31	-0.95	22.81	190.99
836.5	H	27.16	3.31	-0.95	22.90	194.98
847.5	V	26.56	3.34	-0.94	22.28	169.04
847.5	H	29.11	3.34	-0.94	24.83	304.09

* 3 BW 1RB size / 0 Offset for B5

The results shown in this test report refer only to the sample(s) tested unless otherwise stated. This test report cannot be reproduced, except in full, without prior written permission of the Company.

LTE band 5 (3 MHz – 16QAM)

Frequency (MHz)	Ant. Pol. (H/V)	S.G level + Amp. (dB m)	Cable loss (dB)	Ant. gain (dB d)	E.R.P.	
					(dB m)	(mW)
825.5	V	26.68	3.28	-0.95	22.45	175.79
825.5	H	27.05	3.28	-0.95	22.82	191.43
836.5	V	26.11	3.31	-0.95	21.85	153.11
836.5	H	26.35	3.31	-0.95	22.09	161.81
847.5	V	25.98	3.34	-0.94	21.70	147.91
847.5	H	28.16	3.34	-0.94	23.88	244.34

* 3 BW 1RB size / 0 Offset for B5

LTE band 5 (5 MHz – QPSK)

Frequency (MHz)	Ant. Pol. (H/V)	S.G level + Amp. (dB m)	Cable loss (dB)	Ant. gain (dB d)	E.R.P.	
					(dB m)	(mW)
826.5	V	27.65	3.28	-0.95	23.42	219.79
826.5	H	27.91	3.28	-0.95	23.68	233.35
836.5	V	27.35	3.31	-0.95	23.09	203.70
836.5	H	27.67	3.31	-0.95	23.41	219.28
846.5	V	26.92	3.34	-0.94	22.64	183.65
846.5	H	29.18	3.34	-0.94	24.90	309.03

* 5 BW 1RB size / 0 Offset for B5

LTE band 5 (5 MHz – 16QAM)

Frequency (MHz)	Ant. Pol. (H/V)	S.G level + Amp. (dB m)	Cable loss (dB)	Ant. gain (dB d)	E.R.P.	
					(dB m)	(mW)
826.5	V	26.63	3.28	-0.95	22.40	173.78
826.5	H	27.26	3.28	-0.95	23.03	200.91
836.5	V	26.49	3.31	-0.95	22.23	167.11
836.5	H	26.35	3.31	-0.95	22.09	161.81
846.5	V	26.18	3.34	-0.94	21.90	154.88
846.5	H	28.48	3.34	-0.94	24.20	263.03

* 5 BW 1RB size / 0 Offset for B5

The results shown in this test report refer only to the sample(s) tested unless otherwise stated. This test report cannot be reproduced, except in full, without prior written permission of the Company.

LTE band 5 (10 MHz – QPSK)

Frequency (MHz)	Ant. Pol. (H/V)	S.G level + Amp. (dB m)	Cable loss (dB)	Ant. gain (dB d)	E.R.P.	
					(dB m)	(mW)
829.0	V	27.13	3.28	-0.95	22.90	194.98
829.0	H	27.26	3.28	-0.95	23.03	200.91
836.5	V	27.09	3.31	-0.95	22.83	191.87
836.5	H	27.54	3.31	-0.95	23.28	212.81
844.0	V	27.07	3.34	-0.94	22.79	190.11
844.0	H	27.84	3.34	-0.94	23.56	226.99

* 10 BW 1RB size / 0 Offset for B5

LTE band 5 (10 MHz – 16QAM)

Frequency (MHz)	Ant. Pol. (H/V)	S.G level + Amp. (dB m)	Cable loss (dB)	Ant. gain (dB d)	E.R.P.	
					(dB m)	(mW)
829.0	V	26.77	3.28	-0.95	22.54	179.47
829.0	H	27.21	3.28	-0.95	22.98	198.61
836.5	V	26.36	3.31	-0.95	22.10	162.18
836.5	H	26.64	3.31	-0.95	22.38	172.98
844.0	V	26.75	3.34	-0.94	22.47	176.60
844.0	H	27.14	3.34	-0.94	22.86	193.20

* 10 BW 1RB size / 0 Offset for B5

The results shown in this test report refer only to the sample(s) tested unless otherwise stated. This test report cannot be reproduced, except in full, without prior written permission of the Company.

LTE band 17 (5 MHz – QPSK)

Frequency (MHz)	Ant. Pol. (H/V)	S.G level + Amp. (dB m)	Cable loss (dB)	Ant. gain (dB d)	E.R.P.	
					(dB m)	(mW)
706.5	V	22.64	3.03	-0.85	18.76	75.16
706.5	H	17.65	3.03	-0.85	13.77	23.82
710.0	V	22.64	3.04	-0.85	18.75	74.99
710.0	H	17.92	3.04	-0.85	14.03	25.29
713.5	V	22.16	3.04	-0.85	18.27	67.14
713.5	H	18.30	3.04	-0.85	14.41	27.61

* 5 BW 1RB size / 0 Offset for B17

LTE band 17 (5 MHz – 16QAM)

Frequency (MHz)	Ant. Pol. (H/V)	S.G level + Amp. (dB m)	Cable loss (dB)	Ant. gain (dB d)	E.R.P.	
					(dB m)	(mW)
706.5	V	22.12	3.03	-0.85	18.24	66.68
706.5	H	17.36	3.03	-0.85	13.48	22.28
710.0	V	21.81	3.04	-0.85	17.92	61.94
710.0	H	17.08	3.04	-0.85	13.19	20.84
713.5	V	21.55	3.04	-0.85	17.66	58.34
713.5	H	17.19	3.04	-0.85	13.30	21.38

* 5 BW 1RB size / 0 Offset for B17

LTE band 17 (10 MHz – QPSK)

Frequency (MHz)	Ant. Pol. (H/V)	S.G level + Amp. (dB m)	Cable loss (dB)	Ant. gain (dB d)	E.R.P.	
					(dB m)	(mW)
709.0	V	22.87	3.04	-0.85	18.98	79.07
709.0	H	17.94	3.04	-0.85	14.05	25.41
710.0	V	22.32	3.04	-0.85	18.43	69.66
710.0	H	18.16	3.04	-0.85	14.27	26.73
711.0	V	22.43	3.04	-0.85	18.54	71.45
711.0	H	18.03	3.04	-0.85	14.14	25.94

* 10 BW 1RB size / 0 Offset for B17

The results shown in this test report refer only to the sample(s) tested unless otherwise stated. This test report cannot be reproduced, except in full, without prior written permission of the Company.

LTE band 17 (10 MHz – 16QAM)

Frequency (MHz)	Ant. Pol. (H/V)	S.G level + Amp. (dB m)	Cable loss (dB)	Ant. gain (dB d)	E.R.P.	
					(dB m)	(mW)
709.0	V	21.93	3.04	-0.85	18.04	63.68
709.0	H	17.39	3.04	-0.85	13.50	22.39
710.0	V	21.93	3.04	-0.85	18.04	63.68
710.0	H	17.10	3.04	-0.85	13.21	20.94
711.0	V	22.13	3.04	-0.85	18.24	66.68
711.0	H	17.89	3.04	-0.85	14.00	25.12

* 10 BW 1RB size / 0 Offset for B17

The results shown in this test report refer only to the sample(s) tested unless otherwise stated. This test report cannot be reproduced, except in full, without prior written permission of the Company.

LTE band 41 (5 MHz – QPSK)

Frequency (MHz)	Ant. Pol. (H/V)	S.G level + Amp. (dB m)	Cable loss (dB)	Ant. gain (dB d)	E.R.P.	
					(dB m)	(mW)
2 498.5	V	17.94	5.84	8.97	21.07	127.94
2 498.5	H	19.81	5.84	8.97	22.94	196.79
2 593.0	V	19.25	6.01	9.03	22.27	168.66
2 593.0	H	18.82	6.01	9.03	21.84	152.76
2 687.5	V	12.18	6.09	9.09	15.18	32.96
2 687.5	H	14.06	6.09	9.09	17.06	50.82

* 5 BW 1RB size / 0 Offset for B41

LTE band 41 (5 MHz – 16QAM)

Frequency (MHz)	Ant. Pol. (H/V)	S.G level + Amp. (dB m)	Cable loss (dB)	Ant. gain (dB d)	E.R.P.	
					(dB m)	(mW)
2 498.5	V	15.70	5.84	8.97	18.83	76.38
2 498.5	H	17.70	5.84	8.97	20.83	121.06
2 593.0	V	18.65	6.01	9.03	21.67	146.89
2 593.0	H	18.28	6.01	9.03	21.30	134.90
2 687.5	V	10.75	6.09	9.09	13.75	23.71
2 687.5	H	13.03	6.09	9.09	16.03	40.09

* 5 BW 1RB size / 0 Offset for B41

LTE band 41 (10 MHz – QPSK)

Frequency (MHz)	Ant. Pol. (H/V)	S.G level + Amp. (dB m)	Cable loss (dB)	Ant. gain (dB d)	E.R.P.	
					(dB m)	(mW)
2 501.0	V	15.82	5.84	8.97	18.95	78.52
2 501.0	H	18.60	5.84	8.97	21.73	148.94
2 593.0	V	17.44	6.01	9.03	20.46	111.17
2 593.0	H	18.11	6.01	9.03	21.13	129.72
2 685.0	V	11.45	6.09	9.09	14.45	27.86
2 685.0	H	13.24	6.09	9.09	16.24	42.07

* 10 BW 1RB size / 0 Offset for B41

The results shown in this test report refer only to the sample(s) tested unless otherwise stated. This test report cannot be reproduced, except in full, without prior written permission of the Company.

LTE band 41 (10 MHz – 16QAM)

Frequency (MHz)	Ant. Pol. (H/V)	S.G level + Amp. (dB m)	Cable loss (dB)	Ant. gain (dB d)	E.R.P.	
					(dB m)	(mW)
2 501.0	V	16.69	5.84	8.97	19.82	95.94
2 501.0	H	18.91	5.84	8.97	22.04	159.96
2 593.0	V	17.27	6.01	9.03	20.29	106.91
2 593.0	H	17.51	6.01	9.03	20.53	112.98
2 685.0	V	11.01	6.09	9.09	14.01	25.18
2 685.0	H	12.65	6.09	9.09	15.65	36.73

* 10 BW 1RB size / 0 Offset for B41

LTE band 41 (15 MHz – QPSK)

Frequency (MHz)	Ant. Pol. (H/V)	S.G level + Amp. (dB m)	Cable loss (dB)	Ant. gain (dB d)	E.R.P.	
					(dB m)	(mW)
2 503.5	V	16.21	5.85	8.97	19.33	85.70
2 503.5	H	18.95	5.85	8.97	22.07	161.06
2 593.0	V	17.96	6.01	9.03	20.98	125.31
2 593.0	H	18.11	6.01	9.03	21.13	129.72
2 682.5	V	10.26	6.09	9.09	13.26	21.18
2 682.5	H	12.89	6.09	9.09	15.89	38.82

* 15 BW 1RB size / 0 Offset for B41

LTE band 41 (15 MHz – 16QAM)

Frequency (MHz)	Ant. Pol. (H/V)	S.G level + Amp. (dB m)	Cable loss (dB)	Ant. gain (dB d)	E.R.P.	
					(dB m)	(mW)
2 503.5	V	16.05	5.85	8.97	19.17	82.60
2 503.5	H	19.38	5.85	8.97	22.50	177.83
2 593.0	V	16.92	6.01	9.03	19.94	98.63
2 593.0	H	17.22	6.01	9.03	20.24	105.68
2 682.5	V	9.95	6.09	9.09	12.95	19.72
2 682.5	H	11.72	6.09	9.09	14.72	29.65

* 15 BW 1RB size / 0 Offset for B41

The results shown in this test report refer only to the sample(s) tested unless otherwise stated. This test report cannot be reproduced, except in full, without prior written permission of the Company.

LTE band 41 (20 MHz – QPSK)

Frequency (MHz)	Ant. Pol. (H/V)	S.G level + Amp. (dB m)	Cable loss (dB)	Ant. gain (dB d)	E.R.P.	
					(dB m)	(mW)
2 506.0	V	16.98	5.85	8.97	20.10	102.33
2 506.0	H	19.31	5.85	8.97	22.43	174.98
2 593.0	V	18.11	6.01	9.03	21.13	129.72
2 593.0	H	18.82	6.01	9.03	21.84	152.76
2 680.0	V	11.66	6.09	9.09	14.66	29.24
2 680.0	H	13.57	6.09	9.09	16.57	45.39

* 20 BW 1RB size / 0 Offset for B41

LTE band 41 (20 MHz – 16QAM)

Frequency (MHz)	Ant. Pol. (H/V)	S.G level + Amp. (dB m)	Cable loss (dB)	Ant. gain (dB d)	E.R.P.	
					(dB m)	(mW)
2 506.0	V	15.96	5.85	8.97	19.08	80.91
2 506.0	H	18.87	5.85	8.97	21.99	158.12
2 593.0	V	17.48	6.01	9.03	20.50	112.20
2 593.0	H	17.90	6.01	9.03	20.92	123.59
2 680.0	V	10.71	6.09	9.09	13.71	23.50
2 680.0	H	12.70	6.09	9.09	15.70	37.15

* 20 BW 1RB size / 0 Offset for B41

Remark:

1. E.R.P. & E.I.R.P. = [S.G level + Amp.](dB m) - Cable loss(dB) + Ant. gain (dB d/dB i)
2. This device was tested under all bandwidths, and RB configurations, and modulations.
3. The data reported in the table above was measured in worst case.

The results shown in this test report refer only to the sample(s) tested unless otherwise stated. This test report cannot be reproduced, except in full, without prior written permission of the Company.

2.5. Spurious radiated emission

- Measured output Power: 26.10 dB m = 0.407 4 W
- Modulation Signal: GSM850
- Distance: 3 meters
- Limit: $43 + 10\log_{10}(W) = 39.10$ dB c

Frequency (MHz)	Ant. Pol. (H/V)	S.G level + Amp. (dB m)	Cable loss (dB)	Ant. gain (dB d)	E.R.P. (dB m)	dB c	Margin (dB)
Low Channel (824.2 MHz)							
1 648.38	V	-34.78	5.92	5.78	-34.92	61.02	21.92
1 648.39	H	-35.97	5.92	5.78	-36.11	62.21	23.11
2 472.49	V	-48.95	5.80	6.76	-47.99	74.09	34.99
2 472.78	H	-35.87	5.80	6.76	-34.91	61.01	21.91
3 296.51	V	-45.95	7.46	6.93	-46.48	72.58	33.48
3 297.00	H	-43.91	7.46	6.93	-44.44	70.54	31.44
4 120.71	V	-38.76	7.82	7.12	-39.46	65.56	26.46
4 121.25	H	-37.30	7.82	7.12	-38.00	64.10	25.00
Middle Channel (836.6 MHz)							
1 673.17	V	-37.13	6.01	5.78	-37.36	63.46	24.36
1 673.10	H	-39.37	6.01	5.78	-39.60	65.70	26.60
2 510.06	V	-43.87	5.86	6.83	-42.90	69.00	29.90
2 509.85	H	-36.39	5.86	6.83	-35.42	61.52	22.42
3 346.58	V	-48.09	7.54	6.91	-48.72	74.82	35.72
3 346.83	H	-42.57	7.54	6.91	-43.20	69.30	30.20
4 183.06	V	-41.47	7.81	7.16	-42.12	68.22	29.12
4 183.19	H	-37.10	7.81	7.16	-37.75	63.85	24.75
High Channel (848.8 MHz)							
1 697.80	V	-38.34	6.09	5.78	-38.65	64.75	25.65
1 697.49	H	-40.24	6.09	5.78	-40.55	66.65	27.55
2 546.56	V	-39.31	5.93	6.85	-38.39	64.49	25.39
2 546.58	H	-37.57	5.93	6.85	-36.65	62.75	23.65
3 395.32	V	-50.15	7.61	6.88	-50.88	76.98	37.88
3 395.36	H	-41.79	7.61	6.88	-42.52	68.62	29.52
4 243.77	V	-46.67	7.79	7.20	-47.26	73.36	34.26
4 244.29	H	-41.90	7.79	7.20	-42.49	68.59	29.49

The results shown in this test report refer only to the sample(s) tested unless otherwise stated. This test report cannot be reproduced, except in full, without prior written permission of the Company.

- Measured output Power: 19.73 dB m = 0.094 0 W
- Modulation Signal: GSM850 EDGE
- Distance: 3 meters
- Limit: $43 + 10\log_{10}(W) = 32.73$ dB c

Frequency (MHz)	Ant. Pol. (H/V)	S.G level + Amp. (dB m)	Cable loss (dB)	Ant. gain (dB d)	E.R.P. (dB m)	dB c	Margin (dB)
High Channel (848.8 MHz)							
1 697.70	V	-36.03	6.09	5.78	-36.34	56.07	23.34
1 697.52	H	-40.44	6.09	5.78	-40.75	60.48	27.75
2 546.32	V	-41.68	5.93	6.85	-40.76	60.49	27.76
2 546.72	H	-35.30	5.93	6.85	-34.38	54.11	21.38
3 395.22	V	-50.96	7.61	6.88	-51.69	71.42	38.69
3 395.42	H	-43.26	7.61	6.88	-43.99	63.72	30.99
4 243.62	V	-47.56	7.79	7.20	-48.15	67.88	35.15
4 243.73	H	-40.83	7.79	7.20	-41.42	61.15	28.42

The results shown in this test report refer only to the sample(s) tested unless otherwise stated. This test report cannot be reproduced, except in full, without prior written permission of the Company.

- Measured output Power: 26.69 dB m = 0.466 7 W
- Modulation Signal: GSM1900
- Distance: 3 meters
- Limit: $43 + 10\log_{10}(W) = 39.69$ dB c

Frequency (MHz)	Ant. Pol. (H/V)	S.G level + Amp. (dB m)	Cable loss (dB)	Ant. gain (dB i)	E.I.R.P. (dB m)	dB c	Margin (dB)
Low Channel(1 850.2 MHz)							
3 700.33	V	-38.31	8.04	9.07	-37.28	63.97	24.28
3 700.64	H	-36.28	8.04	9.07	-35.25	61.94	22.25
5 550.68	V	-31.78	9.11	10.45	-30.44	57.13	17.44
5 550.51	H	-31.34	9.11	10.45	-30.00	56.69	17.00
7 401.03	V	-28.12	14.62	11.67	-31.07	57.76	18.07
7 400.85	H	-29.45	14.63	11.67	-32.41	59.10	19.41
9 250.54	V	-25.82	11.93	12.35	-25.40	52.09	12.40
9 251.39	H	-26.34	11.93	12.35	-25.92	52.61	12.92
Middle Channel(1 880.0 MHz)							
3 760.13	V	-37.34	8.32	9.10	-36.56	63.25	23.56
3 760.10	H	-32.95	8.32	9.10	-32.17	58.86	19.17
5 640.06	V	-33.22	9.15	10.55	-31.82	58.51	18.82
5 640.17	H	-30.40	9.15	10.55	-29.00	55.69	16.00
7 519.85	V	-32.43	12.89	11.73	-33.59	60.28	20.59
7 519.80	H	-30.40	12.89	11.73	-31.56	58.25	18.56
9 400.12	V	-28.12	11.95	12.44	-27.63	54.32	14.63
9 400.09	H	-27.63	11.95	12.44	-27.14	53.83	14.14
High Channel(1 909.8 MHz)							
3 819.61	V	-38.64	8.49	9.12	-38.01	64.70	25.01
3 819.52	H	-32.05	8.49	9.12	-31.42	58.11	18.42
5 729.42	V	-35.18	9.23	10.64	-33.77	60.46	20.77
5 729.58	H	-31.56	9.23	10.64	-30.15	56.84	17.15
7 638.90	V	-36.69	11.77	11.80	-36.66	63.35	23.66
7 639.54	H	-32.58	11.77	11.80	-32.55	59.24	19.55
9 548.99	V	-27.09	12.16	12.52	-26.73	53.42	13.73
9 549.07	H	-27.72	12.16	12.52	-27.36	54.05	14.36

The results shown in this test report refer only to the sample(s) tested unless otherwise stated. This test report cannot be reproduced, except in full, without prior written permission of the Company.

- Measured output Power: 19.78 dB m = 0.095 1 W
- Modulation Signal: GSM1900 EDGE
- Distance: 3 meters
- Limit: $43 + 10\log_{10}(W) = 32.78$ dB c

Frequency (MHz)	Ant. Pol. (H/V)	S.G level + Amp. (dB m)	Cable loss (dB)	Ant. gain (dB i)	E.I.R.P. (dB m)	dB c	Margin (dB)
High Channel(1 909.8 MHz)							
3 819.48	V	-41.64	8.49	9.12	-41.01	60.79	28.01
3 819.74	H	-34.48	8.49	9.12	-33.85	53.63	20.85
5 729.33	V	-36.55	9.23	10.64	-35.14	54.92	22.14
5 729.26	H	-32.24	9.23	10.64	-30.83	50.61	17.83
7 638.59	V	-38.11	11.78	11.80	-38.09	57.87	25.09
7 638.84	H	-30.70	11.77	11.80	-30.67	50.45	17.67
9 549.11	V	-28.02	12.16	12.52	-27.66	47.44	14.66
9 548.82	H	-28.01	12.16	12.52	-27.65	47.43	14.65

The results shown in this test report refer only to the sample(s) tested unless otherwise stated. This test report cannot be reproduced, except in full, without prior written permission of the Company.

- Measured output Power: 26.33 dB m = 0.429 5 W
- Modulation Signal: WCDMA850
- Distance: 3 meters
- Limit: $43 + 10\log_{10}(W) = 39.33$ dB c

Frequency (MHz)	Ant. Pol. (H/V)	S.G level + Amp. (dB m)	Cable loss (dB)	Ant. gain (dB d)	E.R.P. (dB m)	dB c	Margin (dB)
Low Channel (826.4 MHz)							
1 655.07	V	-39.54	5.94	5.78	-39.70	66.03	26.70
1 655.33	H	-41.68	5.94	5.78	-41.84	68.17	28.84
2 482.97	V	-43.45	5.82	6.78	-42.49	68.82	29.49
2 482.79	H	-42.90	5.82	6.78	-41.94	68.27	28.94
Middle Channel (836.6 MHz)							
1 670.83	V	-41.39	6.00	5.78	-41.61	67.94	28.61
1 670.74	H	-42.33	6.00	5.78	-42.55	68.88	29.55
2 506.22	V	-43.87	5.85	6.82	-42.90	69.23	29.90
2 506.19	H	-41.52	5.85	6.82	-40.55	66.88	27.55
High Channel (846.6 MHz)							
1 691.78	V	-39.45	6.07	5.78	-39.74	66.07	26.74
1 690.83	H	-41.32	6.07	5.78	-41.61	67.94	28.61
2 538.28	V	-43.03	5.91	6.85	-42.09	68.42	29.09
2 536.77	H	-39.97	5.91	6.84	-39.04	65.37	26.04

The results shown in this test report refer only to the sample(s) tested unless otherwise stated. This test report cannot be reproduced, except in full, without prior written permission of the Company.

- Measured output Power : 25.80 dB m = 0.380 2 W
- Modulation Signal : LTE band 5 (1.4 MHz - QPSK)
- Distance : 3 meters
- Limit : $43 + 10\log_{10}(W) = 38.80$ dB c

Frequency (MHz)	Ant. Pol. (H/V)	S.G level + Amp. (dB m)	Cable loss (dB)	Ant. gain (dB d)	E.R.P. (dB m)	dB c	Margin (dB)
Low Channel(824.7 MHz)							
1 648.56	V	-37.73	5.92	5.78	-37.87	63.67	24.87
1 648.58	H	-40.48	5.92	5.78	-40.62	66.42	27.62
Middle Channel(836.5 MHz)							
1 672.09	V	-35.95	6.00	5.78	-36.17	61.97	23.17
1 672.09	H	-40.24	6.00	5.78	-40.46	66.26	27.46
High Channel(848.3 MHz)							
1 695.75	V	-38.46	6.08	5.78	-38.76	64.56	25.76
1 695.59	H	-40.88	6.08	5.78	-41.18	66.98	28.18

* 1.4 BW 1RB size / 0 Offset for B5

The results shown in this test report refer only to the sample(s) tested unless otherwise stated. This test report cannot be reproduced, except in full, without prior written permission of the Company.

- Measured output Power : 24.46 dB m = 0.279 3 W
- Modulation Signal : LTE band 5 (1.4 MHz - 16QAM)
- Distance : 3 meters
- Limit : $43 + 10\log_{10}(W) = 37.46$ dB c

Frequency (MHz)	Ant. Pol. (H/V)	S.G level + Amp. (dB m)	Cable loss (dB)	Ant. gain (dB d)	E.R.P. (dB m)	dB c	Margin (dB)
Low Channel(824.7 MHz)							
1 648.46	V	-37.54	5.92	5.78	-37.68	62.14	24.68
1 648.61	H	-40.50	5.92	5.78	-40.64	65.10	27.64
Middle Channel(836.5 MHz)							
1 672.10	V	-37.93	6.00	5.78	-38.15	62.61	25.15
1 672.12	H	-39.63	6.00	5.78	-39.85	64.31	26.85
High Channel(848.3 MHz)							
1 695.65	V	-38.23	6.08	5.78	-38.53	62.99	25.53
1 695.77	H	-40.36	6.08	5.78	-40.66	65.12	27.66

* 1.4 BW 1RB size / 0 Offset for B5

The results shown in this test report refer only to the sample(s) tested unless otherwise stated. This test report cannot be reproduced, except in full, without prior written permission of the Company.

- Measured output Power : 24.83 dB m = 0.304 1 W
- Modulation Signal : LTE band 5 (3 MHz - QPSK)
- Distance : 3 meters
- Limit : $43 + 10\log_{10}(W) = 37.83$ dB c

Frequency (MHz)	Ant. Pol. (H/V)	S.G level + Amp. (dB m)	Cable loss (dB)	Ant. gain (dB d)	E.R.P. (dB m)	dB c	Margin (dB)
Low Channel(825.5 MHz)							
1 648.54	V	-37.23	5.92	5.78	-37.37	62.20	24.37
1 648.49	H	-40.67	5.92	5.78	-40.81	65.64	27.81
Middle Channel(836.5 MHz)							
1 670.43	V	-37.12	6.00	5.78	-37.34	62.17	24.34
1 670.51	H	-39.71	6.00	5.78	-39.93	64.76	26.93
High Channel(847.5 MHz)							
1 692.49	V	-37.00	6.07	5.78	-37.29	62.12	24.29
1 692.42	H	-38.68	6.07	5.78	-38.97	63.80	25.97

* 3 BW 1RB size / 0 Offset for B5

The results shown in this test report refer only to the sample(s) tested unless otherwise stated. This test report cannot be reproduced, except in full, without prior written permission of the Company.

- Measured output Power : 23.88 dB m = 0.244 3 W
- Modulation Signal : LTE band 5 (3 MHz - 16QAM)
- Distance : 3 meters
- Limit : $43 + 10\log_{10}(W) = 36.88$ dB c

Frequency (MHz)	Ant. Pol. (H/V)	S.G level + Amp. (dB m)	Cable loss (dB)	Ant. gain (dB d)	E.R.P. (dB m)	dB c	Margin (dB)
Low Channel(825.5 MHz)							
1 648.39	V	-37.51	5.92	5.78	-37.65	61.53	24.65
1 648.58	H	-40.77	5.92	5.78	-40.91	64.79	27.91
Middle Channel(836.5 MHz)							
1 670.58	V	-36.90	6.00	5.78	-37.12	61.00	24.12
1 670.48	H	-40.01	6.00	5.78	-40.23	64.11	27.23
High Channel(847.5 MHz)							
1 692.52	V	-36.91	6.07	5.78	-37.20	61.08	24.20
1 692.56	H	-38.99	6.07	5.78	-39.28	63.16	26.28

* 3 BW 1RB size / 0 Offset for B5

The results shown in this test report refer only to the sample(s) tested unless otherwise stated. This test report cannot be reproduced, except in full, without prior written permission of the Company.

- Measured output Power : 24.90 dB m = 0.309 0 W
- Modulation Signal : LTE band 5 (5 MHz - QPSK)
- Distance : 3 meters
- Limit : $43 + 10\log_{10}(W) = 37.90$ dB c

Frequency (MHz)	Ant. Pol. (H/V)	S.G level + Amp. (dB m)	Cable loss (dB)	Ant. gain (dB d)	E.R.P. (dB m)	dB c	Margin (dB)
Low Channel(826.5 MHz)							
1 648.75	V	-37.54	5.92	5.78	-37.68	62.58	24.68
1 648.71	H	-40.89	5.92	5.78	-41.03	65.93	28.03
Middle Channel(836.5 MHz)							
1 668.78	V	-35.85	5.99	5.78	-36.06	60.96	23.06
1 668.72	H	-39.11	5.99	5.78	-39.32	64.22	26.32
High Channel(846.5 MHz)							
1 688.71	V	-37.09	6.06	5.78	-37.37	62.27	24.37
1 688.70	H	-39.57	6.06	5.78	-39.85	64.75	26.85

* 5 BW 1RB size / 0 Offset for B5

The results shown in this test report refer only to the sample(s) tested unless otherwise stated. This test report cannot be reproduced, except in full, without prior written permission of the Company.

- Measured output Power : 24.20 dB m = 0.263 0 W
- Modulation Signal : LTE band 5 (5 MHz - 16QAM)
- Distance : 3 meters
- Limit : $43 + 10\log_{10}(W) = 37.20$ dB c

Frequency (MHz)	Ant. Pol. (H/V)	S.G level + Amp. (dB m)	Cable loss (dB)	Ant. gain (dB d)	E.R.P. (dB m)	dB c	Margin (dB)
Low Channel(826.5 MHz)							
1 648.64	V	-37.31	5.92	5.78	-37.45	61.65	24.45
1 648.75	H	-40.80	5.92	5.78	-40.94	65.14	27.94
Middle Channel(836.5 MHz)							
1 668.65	V	-35.88	5.99	5.78	-36.09	60.29	23.09
1 668.74	H	-39.39	5.99	5.78	-39.60	63.80	26.60
High Channel(846.5 MHz)							
1 688.87	V	-37.00	6.06	5.78	-37.28	61.48	24.28
1 688.77	H	-40.07	6.06	5.78	-40.35	64.55	27.35

* 5 BW 1RB size / 0 Offset for B5

The results shown in this test report refer only to the sample(s) tested unless otherwise stated. This test report cannot be reproduced, except in full, without prior written permission of the Company.

- Measured output Power : 23.56 dB m = 0.227 0 W
- Modulation Signal : LTE band 5 (10 MHz - QPSK)
- Distance : 3 meters
- Limit : $43 + 10\log_{10}(W) = 36.56$ dB c

Frequency (MHz)	Ant. Pol. (H/V)	S.G level + Amp. (dB m)	Cable loss (dB)	Ant. gain (dB d)	E.R.P. (dB m)	dB c	Margin (dB)
Low Channel(829.0 MHz)							
1 649.25	V	-37.62	5.92	5.78	-37.76	61.32	24.76
1 649.28	H	-41.32	5.92	5.78	-41.46	65.02	28.46
Middle Channel(836.5 MHz)							
1 664.25	V	-34.17	5.97	5.78	-34.36	57.92	21.36
1 664.12	H	-38.82	5.97	5.78	-39.01	62.57	26.01
High Channel(844.0 MHz)							
1 679.04	V	-42.36	6.03	5.78	-42.61	66.17	29.61
1 679.29	H	-44.01	6.03	5.78	-44.26	67.82	31.26

* 10 BW 1RB size / 0 Offset for B5

The results shown in this test report refer only to the sample(s) tested unless otherwise stated. This test report cannot be reproduced, except in full, without prior written permission of the Company.

- Measured output Power : 22.98 dB m = 0.198 6 W
- Modulation Signal : LTE band 5 (10 MHz - 16QAM)
- Distance : 3 meters
- Limit : $43 + 10\log_{10}(W) = 35.98$ dB c

Frequency (MHz)	Ant. Pol. (H/V)	S.G level + Amp. (dB m)	Cable loss (dB)	Ant. gain (dB d)	E.R.P. (dB m)	dB c	Margin (dB)
Low Channel(829.0 MHz)							
1 649.25	V	-37.36	5.92	5.78	-37.50	60.48	24.50
1 649.25	H	-41.05	5.92	5.78	-41.19	64.17	28.19
Middle Channel(836.5 MHz)							
1 664.22	V	-34.45	5.97	5.78	-34.64	57.62	21.64
1 664.29	H	-38.71	5.97	5.78	-38.90	61.88	25.90
High Channel(844.0 MHz)							
1 679.22	V	-41.06	6.03	5.78	-41.31	64.29	28.31
1 679.15	H	-42.78	6.03	5.78	-43.03	66.01	30.03

* 10 BW 1RB size / 0 Offset for B5

The results shown in this test report refer only to the sample(s) tested unless otherwise stated. This test report cannot be reproduced, except in full, without prior written permission of the Company.

- Measured output Power : 18.76 dB m = 0.075 2 W
- Modulation Signal : LTE band 17 (5 MHz - QPSK)
- Distance : 3 meters
- Limit : $43 + 10\log_{10}(W) = 31.76$ dB c

Frequency (MHz)	Ant. Pol. (H/V)	S.G level + Amp. (dB m)	Cable loss (dB)	Ant. gain (dB d)	E.R.P. (dB m)	dB c	Margin (dB)
Low Channel(706.5 MHz)							
1 408.58	V	-44.98	4.70	5.41	-44.27	63.03	31.27
1 408.81	H	-40.66	4.70	5.41	-39.95	58.71	26.95
2 113.01	V	-44.17	5.65	5.93	-43.89	62.65	30.89
2 113.03	H	-45.51	5.65	5.93	-45.23	63.99	32.23
Middle Channel(710.0 MHz)							
1 415.70	V	-41.42	4.73	5.44	-40.71	59.47	27.71
1 415.68	H	-37.71	4.73	5.44	-37.00	55.76	24.00
2 123.70	V	-42.01	5.65	5.95	-41.71	60.47	28.71
2 123.64	H	-43.42	5.65	5.95	-43.12	61.88	30.12
High Channel(713.5 MHz)							
1 422.40	V	-39.36	4.75	5.46	-38.65	57.41	25.65
1 422.71	H	-35.74	4.75	5.46	-35.03	53.79	22.03
2 134.10	V	-42.81	5.64	5.98	-42.47	61.23	29.47
2 133.97	H	-43.54	5.64	5.98	-43.20	61.96	30.20

* 5 BW 1RB size / 0 Offset for B17

The results shown in this test report refer only to the sample(s) tested unless otherwise stated. This test report cannot be reproduced, except in full, without prior written permission of the Company.

- Measured output Power : 18.24 dB m = 0.066 7 W
- Modulation Signal : LTE band 17 (5 MHz - 16QAM)
- Distance : 3 meters
- Limit : $43 + 10\log_{10}(W) = 31.24$ dB c

Frequency (MHz)	Ant. Pol. (H/V)	S.G level + Amp. (dB m)	Cable loss (dB)	Ant. gain (dB d)	E.R.P. (dB m)	dB c	Margin (dB)
Low Channel(706.5 MHz)							
1 408.56	V	-44.94	4.70	5.41	-44.23	62.47	31.23
1 408.72	H	-40.93	4.70	5.41	-40.22	58.46	27.22
2 113.04	V	-44.14	5.65	5.93	-43.86	62.10	30.86
2 113.03	H	-45.77	5.65	5.93	-45.49	63.73	32.49
Middle Channel(710.0 MHz)							
1 415.59	V	-41.29	4.73	5.44	-40.58	58.82	27.58
1 415.81	H	-37.79	4.73	5.44	-37.08	55.32	24.08
2 123.49	V	-41.74	5.65	5.95	-41.44	59.68	28.44
2 123.46	H	-43.37	5.65	5.95	-43.07	61.31	30.07
High Channel(713.5 MHz)							
1 422.67	V	-39.35	4.75	5.46	-38.64	56.88	25.64
1 422.75	H	-35.72	4.75	5.46	-35.01	53.25	22.01
2 133.90	V	-41.89	5.64	5.98	-41.55	59.79	28.55
2 133.99	H	-43.28	5.64	5.98	-42.94	61.18	29.94

* 5 BW 1RB size / 0 Offset for B17

The results shown in this test report refer only to the sample(s) tested unless otherwise stated. This test report cannot be reproduced, except in full, without prior written permission of the Company.

- Measured output Power : 18.98 dB m = 0.079 1 W
- Modulation Signal : LTE band 17 (10 MHz - QPSK)
- Distance : 3 meters
- Limit : $43 + 10\log_{10}(W) = 31.98$ dB c

Frequency (MHz)	Ant. Pol. (H/V)	S.G level + Amp. (dB m)	Cable loss (dB)	Ant. gain (dB d)	E.R.P. (dB m)	dB c	Margin (dB)
Low Channel(709.0 MHz)							
1 409.00	V	-45.02	4.70	5.41	-44.31	63.29	31.31
1 409.60	H	-41.07	4.70	5.42	-40.35	59.33	27.35
2 113.69	V	-44.16	5.65	5.93	-43.88	62.86	30.88
2 113.60	H	-45.77	5.65	5.93	-45.49	64.47	32.49
Middle Channel(710.0 MHz)							
1 411.27	V	-44.42	4.71	5.42	-43.71	62.69	30.71
1 411.15	H	-40.43	4.71	5.42	-39.72	58.70	26.72
2 116.68	V	-43.82	5.65	5.94	-43.53	62.51	30.53
2 116.88	H	-44.82	5.65	5.94	-44.53	63.51	31.53
High Channel(711.0 MHz)							
1 413.24	V	-42.78	4.72	5.43	-42.07	61.05	29.07
1 413.13	H	-39.40	4.72	5.43	-38.69	57.67	25.69
2 119.88	V	-42.83	5.65	5.94	-42.54	61.52	29.54
2 119.84	H	-44.00	5.65	5.94	-43.71	62.69	30.71

* 10 BW 1RB size / 0 Offset for B17

The results shown in this test report refer only to the sample(s) tested unless otherwise stated. This test report cannot be reproduced, except in full, without prior written permission of the Company.

- Measured output Power : 18.24 dB m = 0.066 7 W
- Modulation Signal : LTE band 17 (10 MHz - 16QAM)
- Distance : 3 meters
- Limit : $43 + 10\log_{10}(W) = 31.24$ dB c

Frequency (MHz)	Ant. Pol. (H/V)	S.G level + Amp. (dB m)	Cable loss (dB)	Ant. gain (dB d)	E.R.P. (dB m)	dB c	Margin (dB)
Low Channel(709.0 MHz)							
1 409.15	V	-45.00	4.70	5.42	-44.28	62.52	31.28
1 409.28	H	-41.14	4.70	5.42	-40.42	58.66	27.42
2 113.73	V	-43.73	5.65	5.93	-43.45	61.69	30.45
2 113.66	H	-45.55	5.65	5.93	-45.27	63.51	32.27
Middle Channel(710.0 MHz)							
1 411.17	V	-43.74	4.71	5.42	-43.03	61.27	30.03
1 411.16	H	-40.08	4.71	5.42	-39.37	57.61	26.37
2 116.68	V	-43.27	5.65	5.94	-42.98	61.22	29.98
2 116.71	H	-44.65	5.65	5.94	-44.36	62.60	31.36
High Channel(711.0 MHz)							
1 413.30	V	-42.63	4.72	5.43	-41.92	60.16	28.92
1 413.24	H	-38.66	4.72	5.43	-37.95	56.19	24.95
2 119.85	V	-42.97	5.65	5.94	-42.68	60.92	29.68
2 119.73	H	-44.30	5.65	5.94	-44.01	62.25	31.01

* 10 BW 1RB size / 0 Offset for B17

The results shown in this test report refer only to the sample(s) tested unless otherwise stated. This test report cannot be reproduced, except in full, without prior written permission of the Company.

- Measured output Power : 22.94 dB m = 0.196 8 W
- Modulation Signal : LTE band 41 (5 MHz - QPSK)
- Distance : 3 meters
- Limit : $55 + 10\log_{10}(W) = 47.94$ dB c

Frequency (MHz)	Ant. Pol. (H/V)	S.G level + Amp. (dB m)	Cable loss (dB)	Ant. gain (dB d)	E.R.P. (dB m)	dB c	Margin (dB)
Low Channel(2 498.5 MHz)							
4 992.87	V	-30.73	8.32	9.67	-29.38	52.32	4.38
4 992.99	H	-33.65	8.32	9.67	-32.30	55.24	7.30
7 489.08	V	-35.55	13.29	11.72	-37.12	60.06	12.12
7 489.03	H	-34.39	13.29	11.72	-35.96	58.90	10.96
Middle Channel(2 593.0 MHz)							
5 181.60	V	-33.04	8.60	9.94	-31.70	54.64	6.70
5 181.56	H	-29.40	8.60	9.94	-28.06	51.00	3.06
7 772.50	V	-32.22	11.25	11.86	-31.61	54.55	6.61
7 772.43	H	-32.50	11.25	11.86	-31.89	54.83	6.89
High Channel(2 687.5 MHz)							
5 371.08	V	-30.34	8.72	10.22	-28.84	51.78	3.84
5 370.99	H	-30.36	8.72	10.22	-28.86	51.80	3.86
8 056.21	V	-34.55	11.02	11.99	-33.58	56.52	8.58
8 056.03	H	-32.64	11.02	11.99	-31.67	54.61	6.67

* 5 BW 1RB size / 0 Offset for B41

The results shown in this test report refer only to the sample(s) tested unless otherwise stated. This test report cannot be reproduced, except in full, without prior written permission of the Company.

- Measured output Power : 21.67 dB m = 0.146 9 W
- Modulation Signal : LTE band 41 (5 MHz - 16QAM)
- Distance : 3 meters
- Limit : $55 + 10\log_{10}(W) = 46.67$ dB c

Frequency (MHz)	Ant. Pol. (H/V)	S.G level + Amp. (dB m)	Cable loss (dB)	Ant. gain (dB d)	E.R.P. (dB m)	dB c	Margin (dB)
Low Channel(2 498.5 MHz)							
4 992.90	V	-31.63	8.32	9.67	-30.28	51.95	5.28
4 992.87	H	-34.43	8.32	9.67	-33.08	54.75	8.08
7 488.92	V	-35.21	13.29	11.71	-36.79	58.46	11.79
7 488.89	H	-34.20	13.29	11.71	-35.78	57.45	10.78
Middle Channel(2 593.0 MHz)							
5 181.71	V	-33.37	8.60	9.94	-32.03	53.70	7.03
5 181.66	H	-30.50	8.60	9.94	-29.16	50.83	4.16
7 772.55	V	-32.67	11.25	11.86	-32.06	53.73	7.06
7 772.54	H	-33.49	11.25	11.86	-32.88	54.55	7.88
High Channel(2 687.5 MHz)							
5 370.80	V	-30.37	8.72	10.22	-28.87	50.54	3.87
5 370.88	H	-30.16	8.72	10.22	-28.66	50.33	3.66
8 055.87	V	-34.77	11.02	11.99	-33.80	55.47	8.80
8 055.93	H	-32.86	11.02	11.99	-31.89	53.56	6.89

* 5 BW 1RB size / 0 Offset for B41

The results shown in this test report refer only to the sample(s) tested unless otherwise stated. This test report cannot be reproduced, except in full, without prior written permission of the Company.

- Measured output Power : 21.73 dB m = 0.148 9 W
- Modulation Signal : LTE band 41 (10 MHz - QPSK)
- Distance : 3 meters
- Limit : $55 + 10\log_{10}(W) = 46.73$ dB c

Frequency (MHz)	Ant. Pol. (H/V)	S.G level + Amp. (dB m)	Cable loss (dB)	Ant. gain (dB d)	E.R.P. (dB m)	dB c	Margin (dB)
Low Channel(2 501.0 MHz)							
4 993.70	V	-30.72	8.32	9.67	-29.37	51.10	4.37
4 993.78	H	-32.64	8.32	9.67	-31.29	53.02	6.29
7 489.88	V	-34.34	13.28	11.72	-35.90	57.63	10.90
7 489.82	H	-33.14	13.28	11.72	-34.70	56.43	9.70
Middle Channel(2 593.0 MHz)							
5 177.08	V	-32.45	8.59	9.94	-31.10	52.83	6.10
5 177.10	H	-29.85	8.59	9.94	-28.50	50.23	3.50
7 765.71	V	-32.47	11.28	11.86	-31.89	53.62	6.89
7 765.75	H	-33.23	11.28	11.86	-32.65	54.38	7.65
High Channel(2 685.0 MHz)							
5 361.31	V	-36.35	8.71	10.20	-34.86	56.59	9.86
5 361.23	H	-35.52	8.71	10.20	-34.03	55.76	9.03
8 041.78	V	-32.80	11.02	11.98	-31.84	53.57	6.84
8 041.76	H	-33.97	11.02	11.98	-33.01	54.74	8.01

* 10 BW 1RB size / 0 Offset for B41

The results shown in this test report refer only to the sample(s) tested unless otherwise stated. This test report cannot be reproduced, except in full, without prior written permission of the Company.

- Measured output Power : 22.04 dB m = 0.160 0 W
- Modulation Signal : LTE band 41 (10 MHz - 16QAM)
- Distance : 3 meters
- Limit : $55 + 10\log_{10}(W) = 47.04$ dB c

Frequency (MHz)	Ant. Pol. (H/V)	S.G level + Amp. (dB m)	Cable loss (dB)	Ant. gain (dB d)	E.R.P. (dB m)	dB c	Margin (dB)
Low Channel(2 501.0 MHz)							
4 993.61	V	-30.73	8.32	9.67	-29.38	51.42	4.38
4 993.67	H	-33.31	8.32	9.67	-31.96	54.00	6.96
7 489.70	V	-34.34	13.28	11.72	-35.90	57.94	10.90
7 489.73	H	-33.58	13.28	11.72	-35.14	57.18	10.14
Middle Channel(2 593.0 MHz)							
5 177.29	V	-33.10	8.59	9.94	-31.75	53.79	6.75
5 177.34	H	-29.80	8.59	9.94	-28.45	50.49	3.45
7 765.68	V	-32.30	11.28	11.86	-31.72	53.76	6.72
7 765.80	H	-33.21	11.28	11.86	-32.63	54.67	7.63
High Channel(2 685.0 MHz)							
5 361.23	V	-37.04	8.71	10.20	-35.55	57.59	10.55
5 361.20	H	-36.19	8.71	10.20	-34.70	56.74	9.70
8 041.80	V	-32.70	11.02	11.98	-31.74	53.78	6.74
8 041.83	H	-30.68	11.02	11.98	-29.72	51.76	4.72

* 10 BW 1RB size / 0 Offset for B41

The results shown in this test report refer only to the sample(s) tested unless otherwise stated. This test report cannot be reproduced, except in full, without prior written permission of the Company.

- Measured output Power : 22.07 dB m = 0.161 1 W
- Modulation Signal : LTE band 41 (15 MHz - QPSK)
- Distance : 3 meters
- Limit : $55 + 10\log_{10}(W) = 47.07$ dB c

Frequency (MHz)	Ant. Pol. (H/V)	S.G level + Amp. (dB m)	Cable loss (dB)	Ant. gain (dB d)	E.R.P. (dB m)	dB c	Margin (dB)
Low Channel(2 503.5 MHz)							
4 993.70	V	-29.54	8.32	9.67	-28.19	50.26	3.19
4 993.78	H	-32.00	8.32	9.67	-30.65	52.72	5.65
7 490.49	V	-33.92	13.27	11.72	-35.47	57.54	10.47
7 490.59	H	-32.90	13.27	11.72	-34.45	56.52	9.45
Middle Channel(2 593.0 MHz)							
5 172.66	V	-32.12	8.58	9.93	-30.77	52.84	5.77
5 172.68	H	-29.51	8.58	9.93	-28.16	50.23	3.16
7 759.10	V	-32.59	11.30	11.85	-32.04	54.11	7.04
7 759.03	H	-33.02	11.30	11.85	-32.47	54.54	7.47
High Channel(2 682.5 MHz)							
5 351.71	V	-36.43	8.71	10.19	-34.95	57.02	9.95
5 351.67	H	-35.66	8.71	10.19	-34.18	56.25	9.18
8 027.71	V	-42.48	11.02	11.98	-41.52	63.59	16.52
8 027.50	H	-40.53	11.02	11.98	-39.57	61.64	14.57

* 15 BW 1RB size / 0 Offset for B41

The results shown in this test report refer only to the sample(s) tested unless otherwise stated. This test report cannot be reproduced, except in full, without prior written permission of the Company.

- Measured output Power : 22.50 dB m = 0.177 8 W
- Modulation Signal : LTE band 41 (15 MHz - 16QAM)
- Distance : 3 meters
- Limit : $55 + 10\log_{10}(W) = 47.50$ dB c

Frequency (MHz)	Ant. Pol. (H/V)	S.G level + Amp. (dB m)	Cable loss (dB)	Ant. gain (dB d)	E.R.P. (dB m)	dB c	Margin (dB)
Low Channel(2 503.5 MHz)							
4 993.63	V	-30.72	8.32	9.67	-29.37	51.87	4.37
4 993.61	H	-33.35	8.32	9.67	-32.00	54.50	7.00
7 490.42	V	-34.48	13.27	11.72	-36.03	58.53	11.03
7 490.51	H	-33.72	13.27	11.72	-35.27	57.77	10.27
Middle Channel(2 593.0 MHz)							
5 172.70	V	-32.58	8.58	9.93	-31.23	53.73	6.23
5 172.66	H	-29.94	8.58	9.93	-28.59	51.09	3.59
7 758.79	V	-31.73	11.30	11.85	-31.18	53.68	6.18
7 758.99	H	-32.23	11.30	11.85	-31.68	54.18	6.68
High Channel(2 682.5 MHz)							
5 351.90	V	-37.09	8.71	10.19	-35.61	58.11	10.61
5 351.87	H	-36.41	8.71	10.19	-34.93	57.43	9.93
8 027.50	V	-42.22	11.02	11.98	-41.26	63.76	16.26
8 027.53	H	-40.56	11.02	11.98	-39.60	62.10	14.60

* 15 BW 1RB size / 0 Offset for B41

The results shown in this test report refer only to the sample(s) tested unless otherwise stated. This test report cannot be reproduced, except in full, without prior written permission of the Company.

- Measured output Power : 22.43 dB m = 0.175 0 W
- Modulation Signal : LTE band 41 (20 MHz - QPSK)
- Distance : 3 meters
- Limit : $55 + 10\log_{10}(W) = 47.43$ dB c

Frequency (MHz)	Ant. Pol. (H/V)	S.G level + Amp. (dB m)	Cable loss (dB)	Ant. gain (dB d)	E.R.P. (dB m)	dB c	Margin (dB)
Low Channel(2 506.0 MHz)							
4 994.40	V	-29.70	8.32	9.67	-28.35	50.78	3.35
4 994.26	H	-32.81	8.32	9.67	-31.46	53.89	6.46
7 491.50	V	-32.96	13.25	11.72	-34.49	56.92	9.49
7 491.32	H	-31.69	13.26	11.72	-33.23	55.66	8.23
Middle Channel(2 593.0 MHz)							
5 168.22	V	-32.19	8.57	9.92	-30.84	53.27	5.84
5 168.17	H	-29.76	8.57	9.92	-28.41	50.84	3.41
7 752.16	V	-33.16	11.33	11.85	-32.64	55.07	7.64
7 752.29	H	-33.17	11.33	11.85	-32.65	55.08	7.65
High Channel(2 680.0 MHz)							
5 342.20	V	-38.95	8.71	10.18	-37.48	59.91	12.48
5 342.23	H	-37.83	8.71	10.18	-36.36	58.79	11.36
8 013.27	V	-42.72	11.02	11.98	-41.76	64.19	16.76
8 013.29	H	-40.35	11.02	11.98	-39.39	61.82	14.39

* 20 BW 1RB size / 0 Offset for B41

The results shown in this test report refer only to the sample(s) tested unless otherwise stated. This test report cannot be reproduced, except in full, without prior written permission of the Company.

- Measured output Power : 21.99 dB m = 0.158 1 W
- Modulation Signal : LTE band 41 (20 MHz - 16QAM)
- Distance : 3 meters
- Limit : $55 + 10\log_{10}(W) = 46.99$ dB c

Frequency (MHz)	Ant. Pol. (H/V)	S.G level + Amp. (dB m)	Cable loss (dB)	Ant. gain (dB d)	E.R.P. (dB m)	dB c	Margin (dB)
Low Channel(2 506.0 MHz)							
4 994.31	V	-30.38	8.32	9.67	-29.03	51.02	4.03
4 994.27	H	-33.01	8.32	9.67	-31.66	53.65	6.66
7 491.20	V	-33.30	13.26	11.72	-34.84	56.83	9.84
7 491.13	H	-32.24	13.26	11.72	-33.78	55.77	8.78
Middle Channel(2 593.0 MHz)							
5 168.39	V	-32.17	8.57	9.92	-30.82	52.81	5.82
5 168.22	H	-30.24	8.57	9.92	-28.89	50.88	3.89
7 752.31	V	-32.63	11.33	11.85	-32.11	54.10	7.11
7 752.22	H	-32.49	11.33	11.85	-31.97	53.96	6.97
High Channel(2 680.0 MHz)							
5 342.34	V	-38.84	8.71	10.18	-37.37	59.36	12.37
5 342.21	H	-37.61	8.71	10.18	-36.14	58.13	11.14
8 013.10	V	-43.02	11.02	11.98	-42.06	64.05	17.06
8 013.15	H	-41.14	11.02	11.98	-40.18	62.17	15.18

* 20 BW 1RB size / 0 Offset for B41

Remark:

1. E.R.P. & E.I.R.P. = [S.G level + Amp.](dB m) - Cable loss(dB) + Ant. gain (dB d/dB i)
2. This device was tested under all bandwidths, and RB configurations, and modulations.
3. The data reported in the table above was measured in worst case.

The results shown in this test report refer only to the sample(s) tested unless otherwise stated. This test report cannot be reproduced, except in full, without prior written permission of the Company.

3. Occupied Bandwidth 99 %

3.1. Limit

Requirements: CFR 47, Section §2.1049.

3.2. Test Procedure

The test follows section 4.2 of FCC KDB Publication 971168_v02r02.

1. Set span = 2 – 5 x OBW.
2. Set resolution bandwidth (RBW) = 1 – 5 % of OBW.
3. Set video bandwidth (VBW) $\geq 3 \times$ RBW.
4. Detector = Peak.
5. Trace mode = max hold.
6. Use the 99 % power bandwidth function of the spectrum analyzer (if available) and report the measured bandwidth.

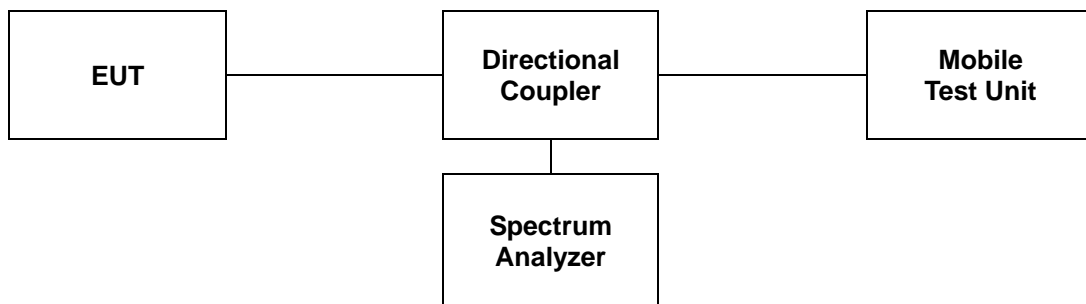

The results shown in this test report refer only to the sample(s) tested unless otherwise stated. This test report cannot be reproduced, except in full, without prior written permission of the Company.

3.3 Test Results

Ambient temperature : (24 ± 1) °C
 Relative humidity : 47 % R.H.

Band	Mode	Frequency (MHz)	Occupied Bandwidth (MHz)
GSM850	GSM GPRS	824.2	0.244
		836.6	0.248
		848.8	0.248
GSM850	GSM EDGE	824.2	0.242
		836.6	0.246
		848.8	0.254
GSM1900	GSM GPRS	1 850.2	0.246
		1 880.0	0.247
		1 909.8	0.245
GSM1900	GSM EDGE	1 850.2	0.243
		1 880.0	0.245
		1 909.8	0.238
WCDMA850	12.2 kbps (RMC)	826.4	4.135
		836.6	4.151
		846.6	4.140
LTE 5 (1.4 MHz)	QPSK	824.7	1.095
		836.5	1.092
		848.3	1.104
LTE 5 (1.4 MHz)	16QAM	824.7	1.096
		836.5	1.096
		848.3	1.093
LTE 5 (3 MHz)	QPSK	825.5	2.709
		836.5	2.699
		847.5	2.704
LTE 5 (3 MHz)	16QAM	825.5	2.703
		836.5	2.695
		847.5	2.696
LTE 5 (5 MHz)	QPSK	826.5	4.504
		836.5	4.508
		846.5	4.501
LTE 5 (5 MHz)	16QAM	826.5	4.506
		836.5	4.507
		846.5	4.505
LTE 5 (10 MHz)	QPSK	829.0	8.962
		836.5	8.963
		844.0	8.960
LTE 5 (10 MHz)	16QAM	829.0	8.967
		836.5	8.975
		844.0	8.962

The results shown in this test report refer only to the sample(s) tested unless otherwise stated. This test report cannot be reproduced, except in full, without prior written permission of the Company.

Band	Mode	Frequency (MHz)	Occupied Bandwidth (MHz)
LTE 17 (5 MHz)	QPSK	706.5	4.513
		710.0	4.507
		713.5	4.499
LTE 17 (5 MHz)	16QAM	706.5	4.507
		710.0	4.507
		713.5	4.504
LTE 17 (10 MHz)	QPSK	709.0	8.968
		710.0	8.950
		711.0	8.963
LTE 17 (10 MHz)	16QAM	709.0	8.956
		710.0	8.957
		711.0	8.947
LTE 41 (5 MHz)	QPSK	2 498.5	4.511
		2 593.0	4.524
		2 687.5	4.507
LTE 41 (5 MHz)	16QAM	2 498.5	4.508
		2 593.0	4.509
		2 687.5	4.509
LTE 41 (10 MHz)	QPSK	2 501.0	8.954
		2 593.0	8.951
		2 685.0	8.945
LTE 41 (10 MHz)	16QAM	2 501.0	8.954
		2 593.0	8.953
		2 685.0	8.948
LTE 41 (15 MHz)	QPSK	2 503.5	13.429
		2 593.0	13.432
		2 682.5	13.422
LTE 41 (15 MHz)	16QAM	2 503.5	13.373
		2 593.0	13.439
		2 682.5	13.475
LTE 41 (20 MHz)	QPSK	2 506.0	17.925
		2 593.0	17.879
		2 680.0	17.820
LTE 41 (20 MHz)	16QAM	2 506.0	17.912
		2 593.0	17.897
		2 680.0	17.892

Please refer to the following plots.

The results shown in this test report refer only to the sample(s) tested unless otherwise stated. This test report cannot be reproduced, except in full, without prior written permission of the Company.

GSM850
Low Channel

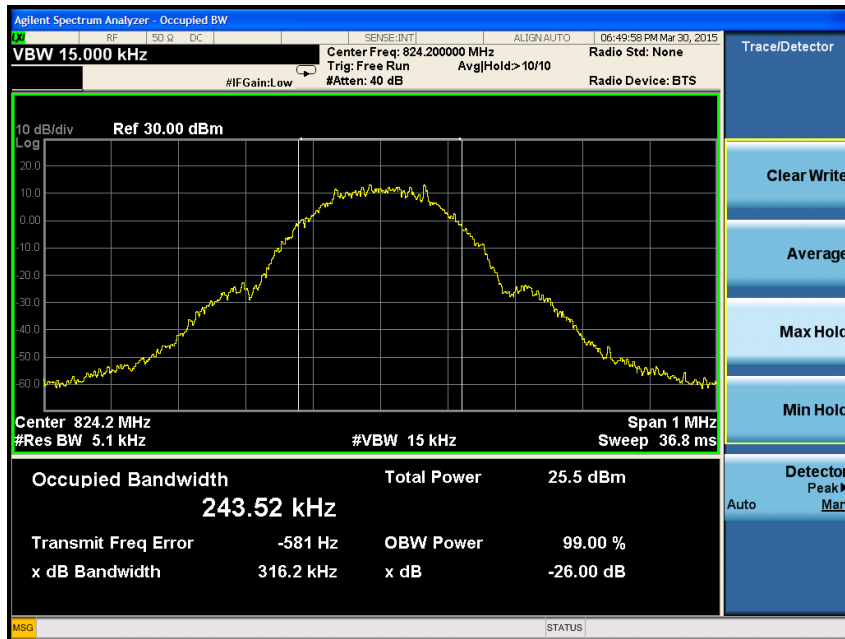

Middle Channel

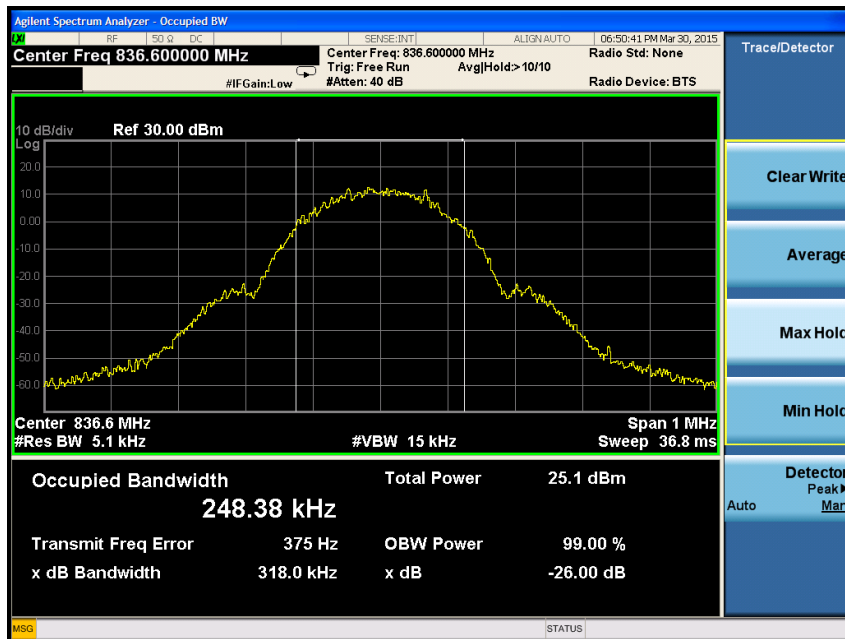

The results shown in this test report refer only to the sample(s) tested unless otherwise stated. This test report cannot be reproduced, except in full, without prior written permission of the Company.

High Channel

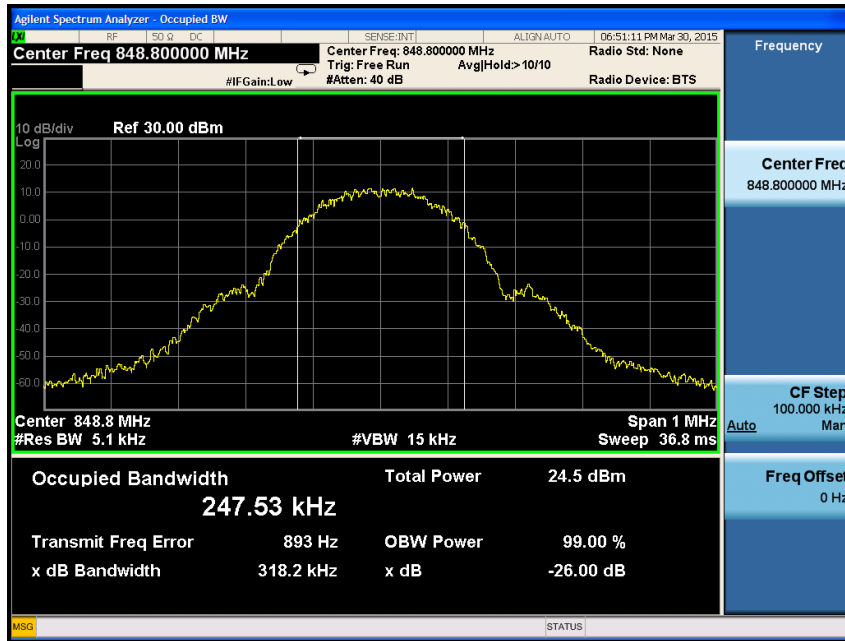

The results shown in this test report refer only to the sample(s) tested unless otherwise stated. This test report cannot be reproduced, except in full, without prior written permission of the Company.

EDGE850
Low Channel

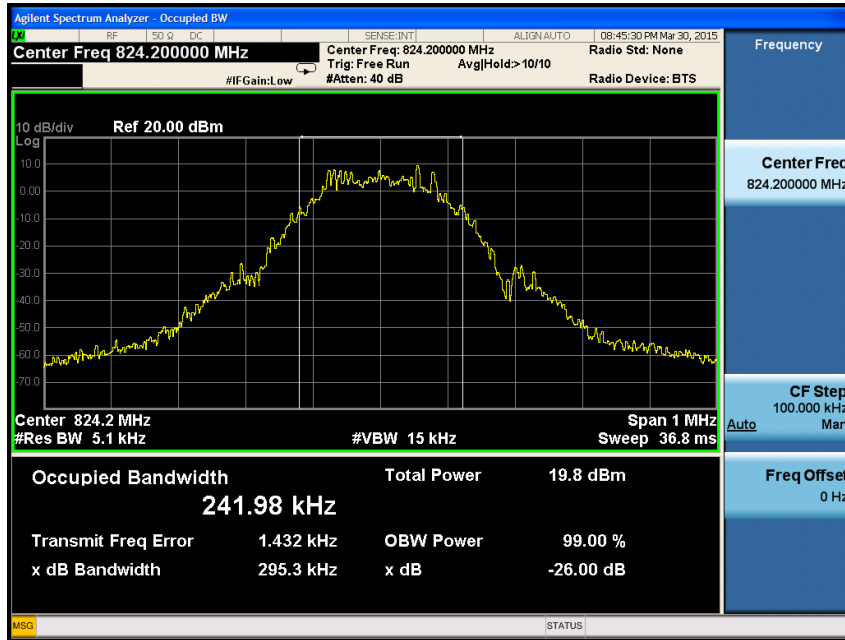

Middle Channel

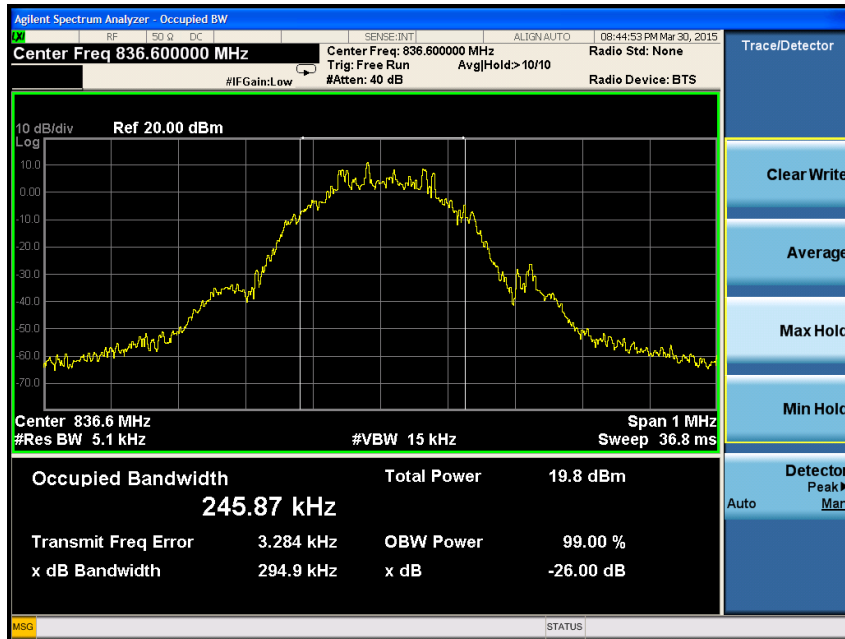

The results shown in this test report refer only to the sample(s) tested unless otherwise stated. This test report cannot be reproduced, except in full, without prior written permission of the Company.

High Channel

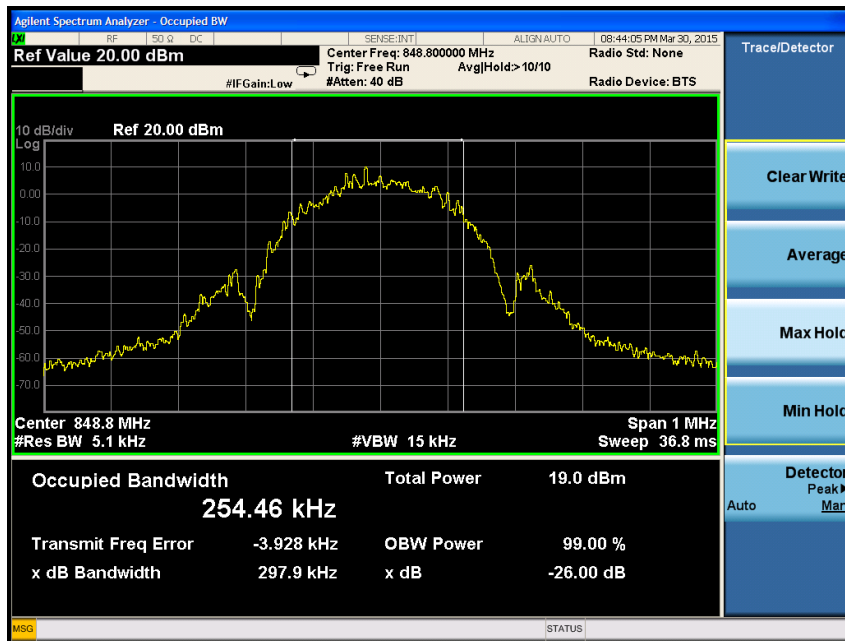

The results shown in this test report refer only to the sample(s) tested unless otherwise stated. This test report cannot be reproduced, except in full, without prior written permission of the Company.

GSM1900
Low Channel

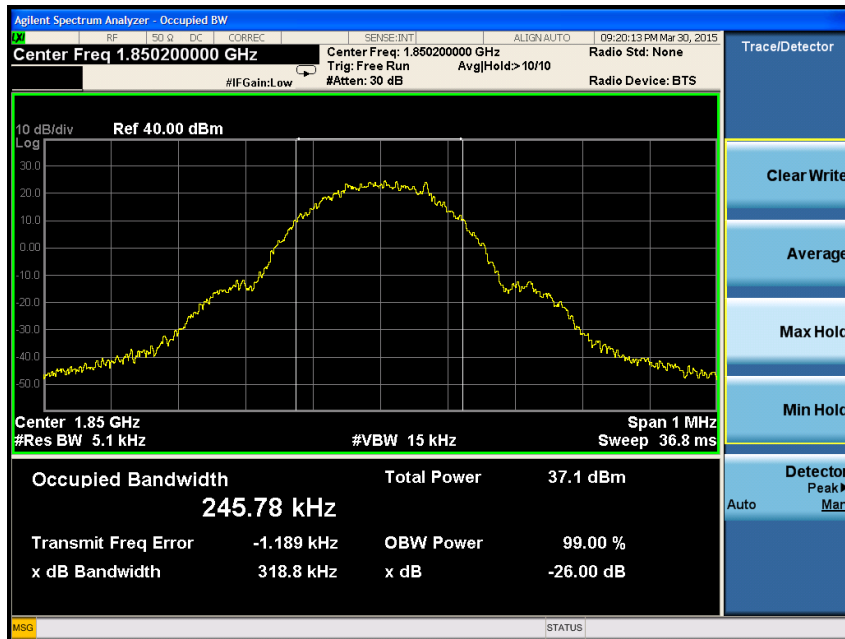

Middle Channel

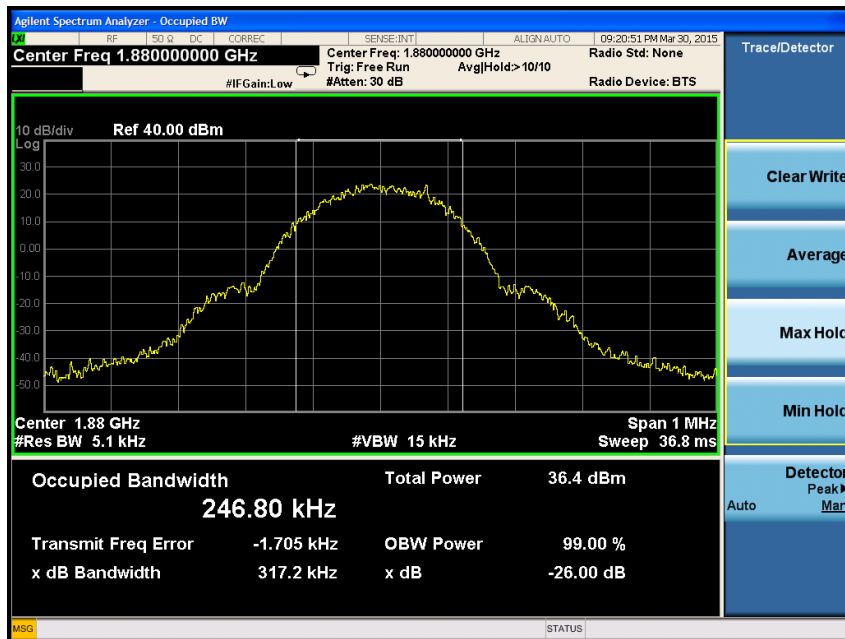

The results shown in this test report refer only to the sample(s) tested unless otherwise stated. This test report cannot be reproduced, except in full, without prior written permission of the Company.

High Channel

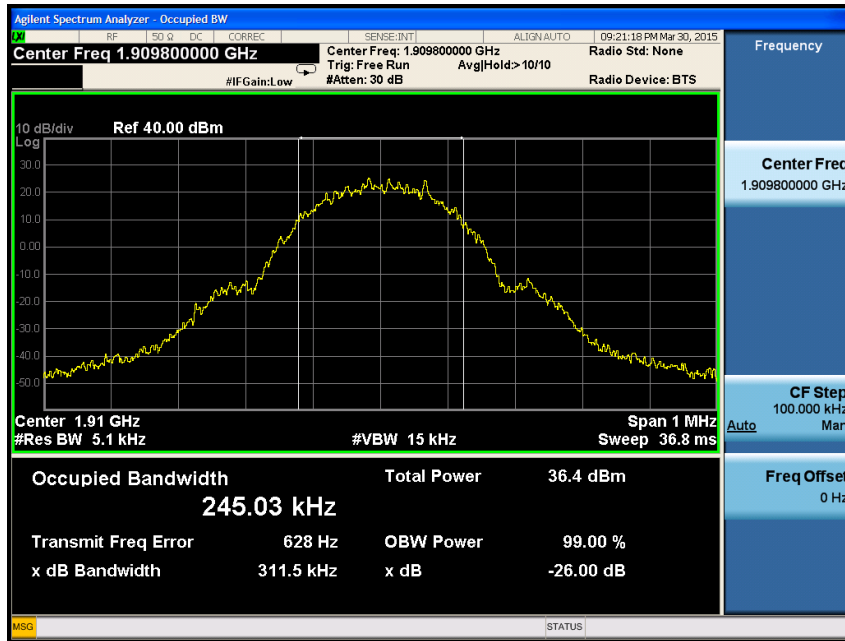

The results shown in this test report refer only to the sample(s) tested unless otherwise stated. This test report cannot be reproduced, except in full, without prior written permission of the Company.

EDGE1900
Low Channel

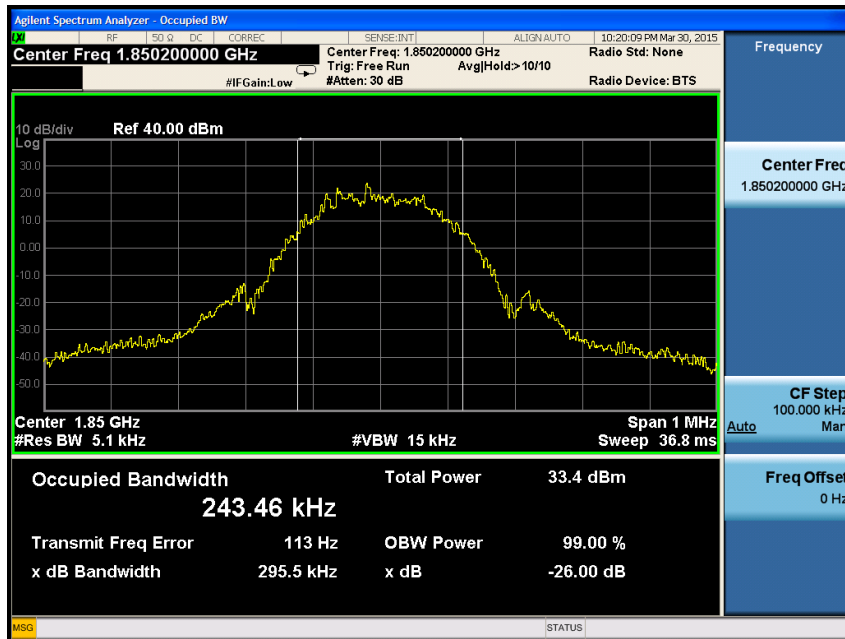

Middle Channel

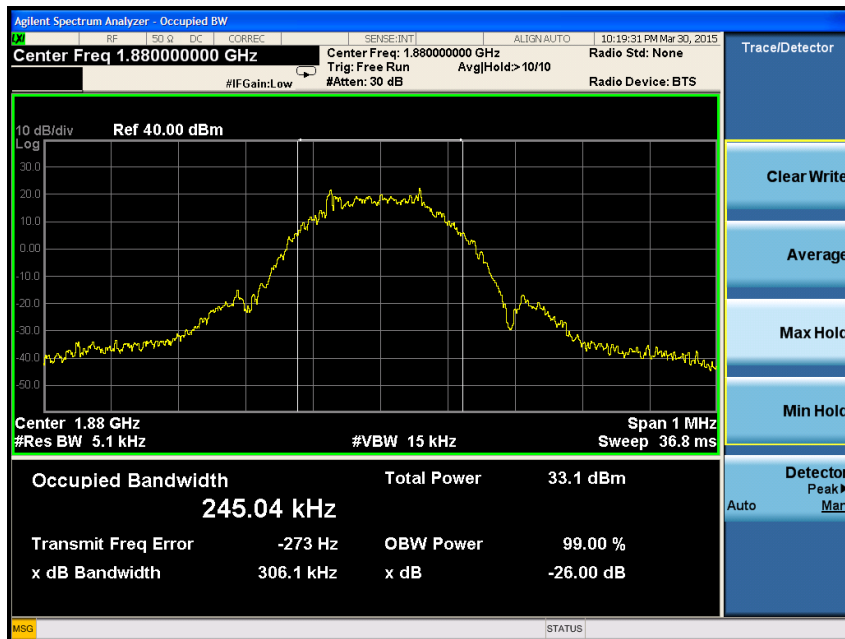

The results shown in this test report refer only to the sample(s) tested unless otherwise stated. This test report cannot be reproduced, except in full, without prior written permission of the Company.

High Channel

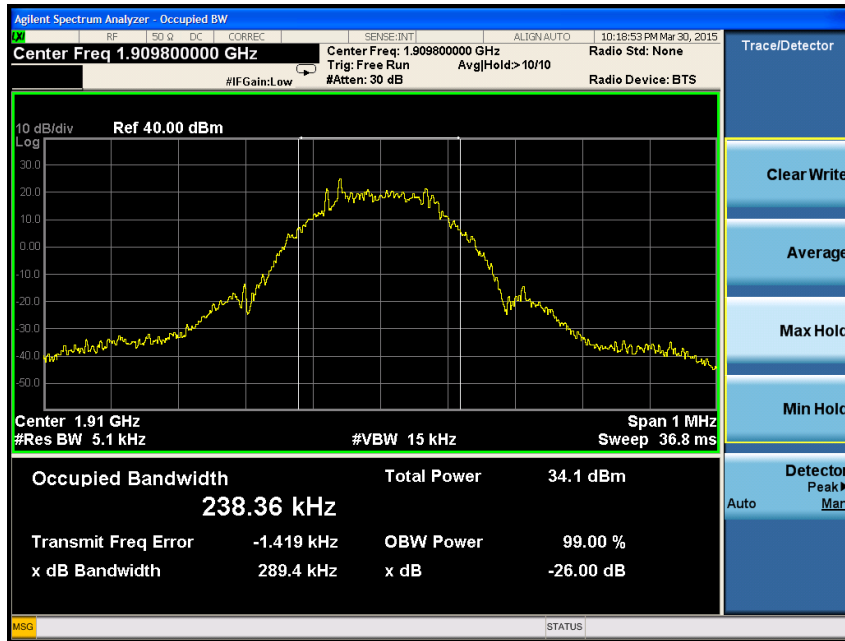

The results shown in this test report refer only to the sample(s) tested unless otherwise stated. This test report cannot be reproduced, except in full, without prior written permission of the Company.

WCDMA850
Low Channel

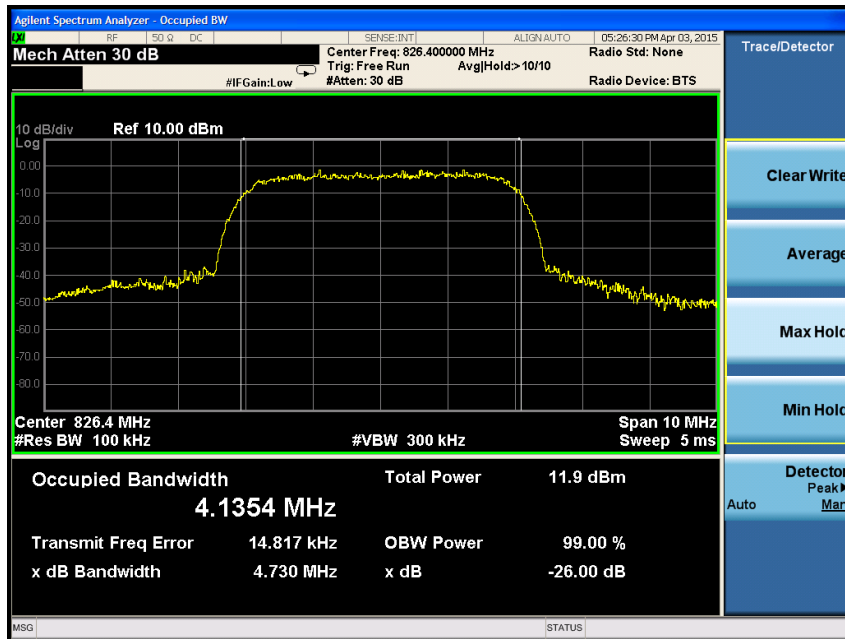

Middle Channel

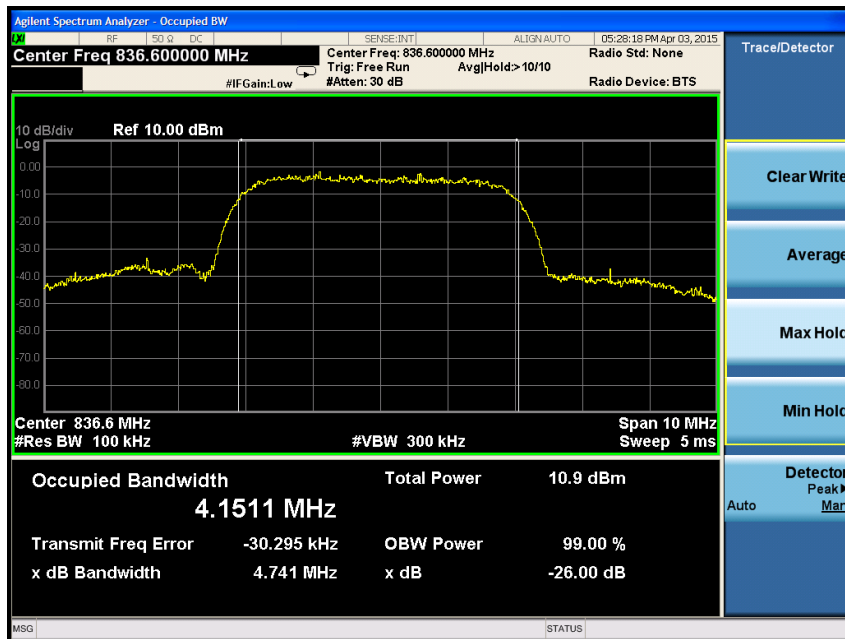

The results shown in this test report refer only to the sample(s) tested unless otherwise stated. This test report cannot be reproduced, except in full, without prior written permission of the Company.

High Channel

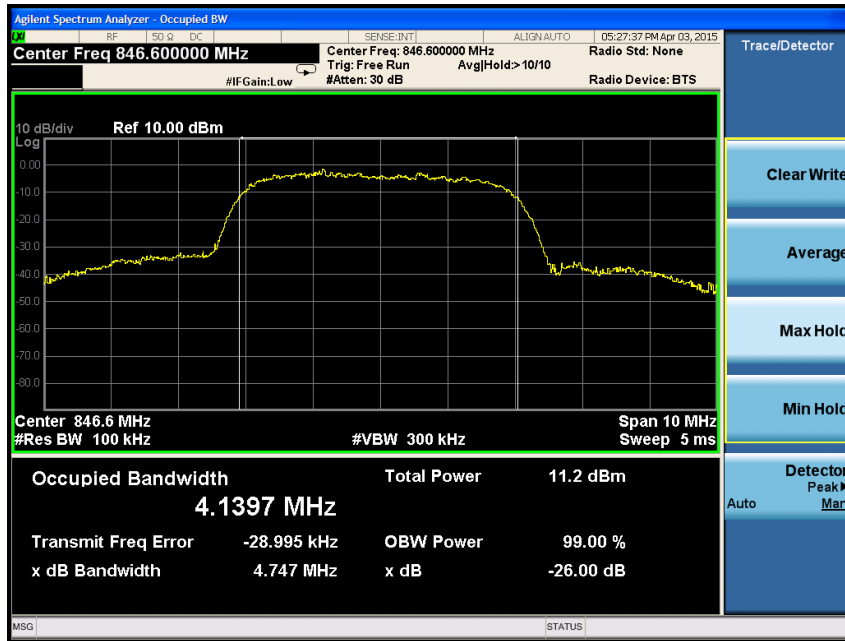

The results shown in this test report refer only to the sample(s) tested unless otherwise stated. This test report cannot be reproduced, except in full, without prior written permission of the Company.

LTE band 5 (1.4 MHz – QPSK_RB 6)

Low Channel

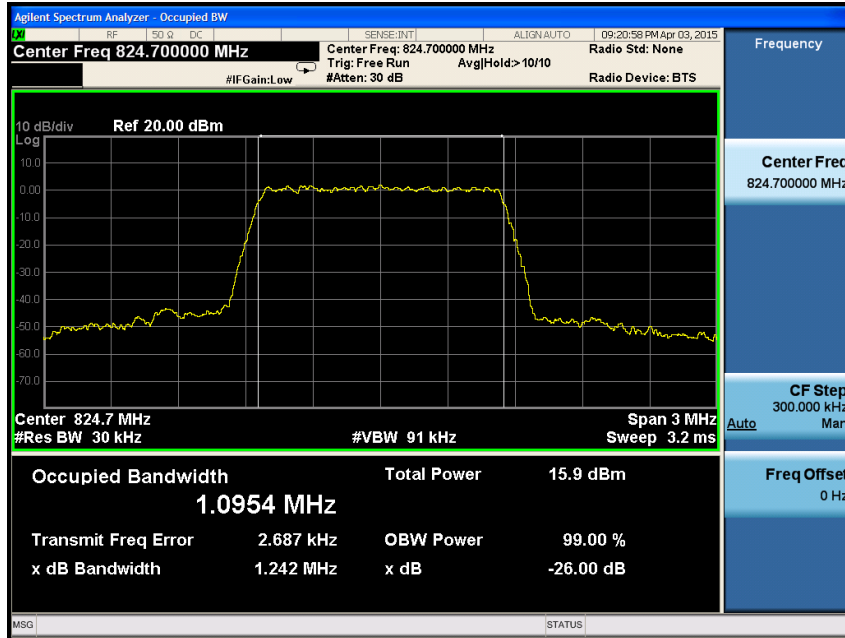

Middle Channel

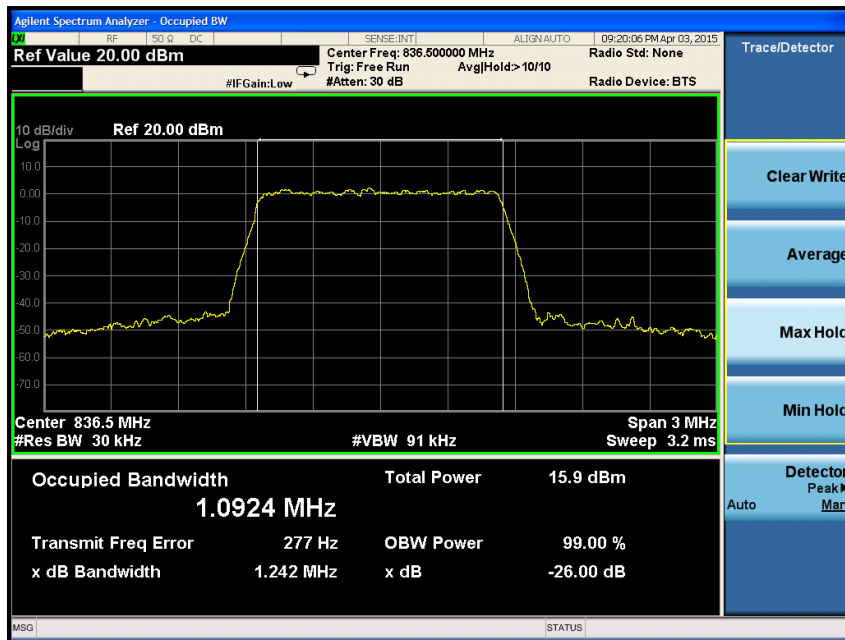

The results shown in this test report refer only to the sample(s) tested unless otherwise stated. This test report cannot be reproduced, except in full, without prior written permission of the Company.

High Channel

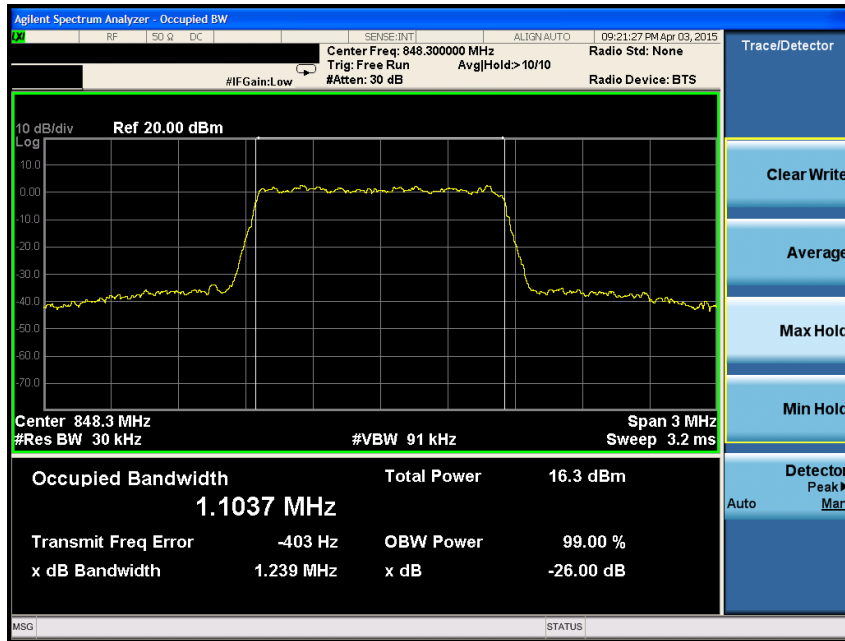

The results shown in this test report refer only to the sample(s) tested unless otherwise stated. This test report cannot be reproduced, except in full, without prior written permission of the Company.

LTE band 5 (1.4 MHz – 16QAM_RB 6)

Low Channel

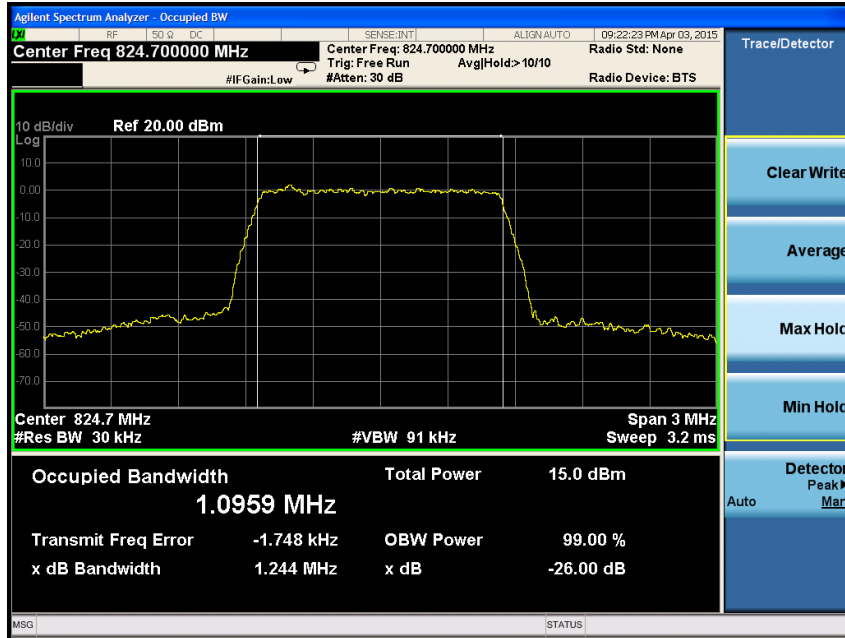

Middle Channel

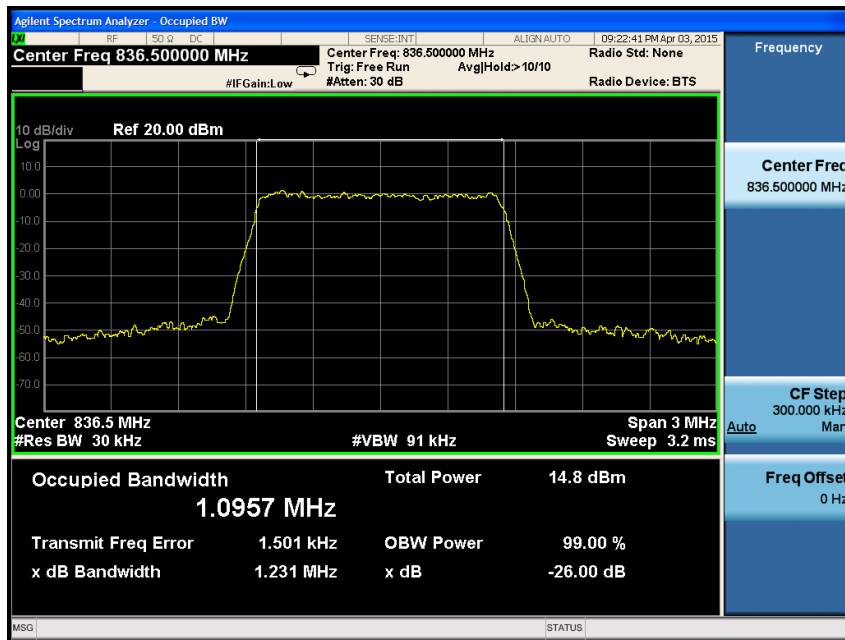

The results shown in this test report refer only to the sample(s) tested unless otherwise stated. This test report cannot be reproduced, except in full, without prior written permission of the Company.

High Channel

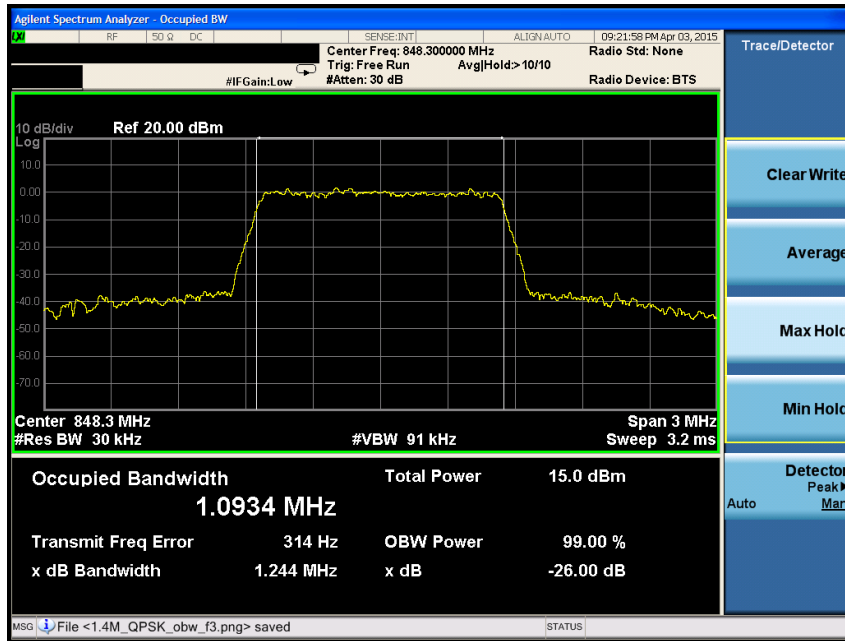

The results shown in this test report refer only to the sample(s) tested unless otherwise stated. This test report cannot be reproduced, except in full, without prior written permission of the Company.

LTE band 5 (3 MHz – QPSK_RB 15)

Low Channel

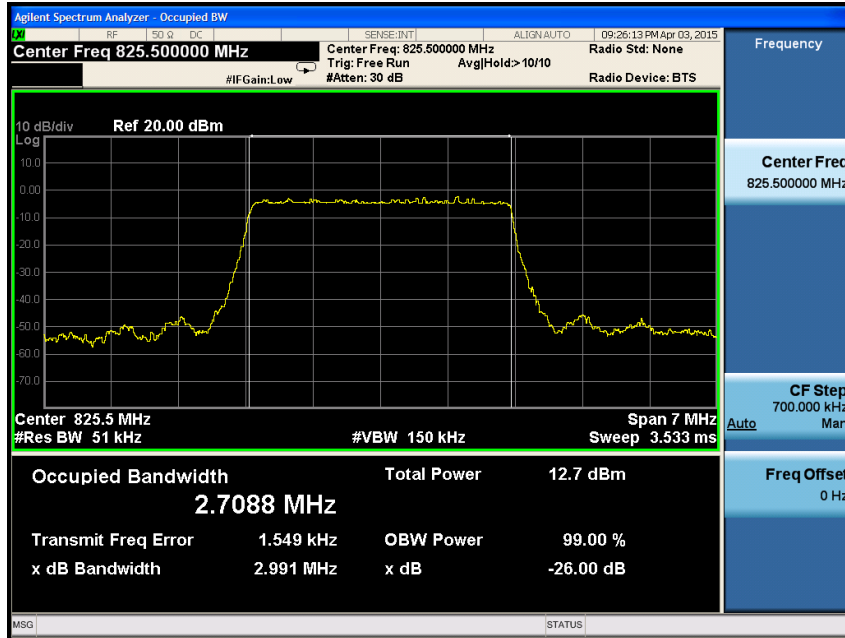

Middle Channel

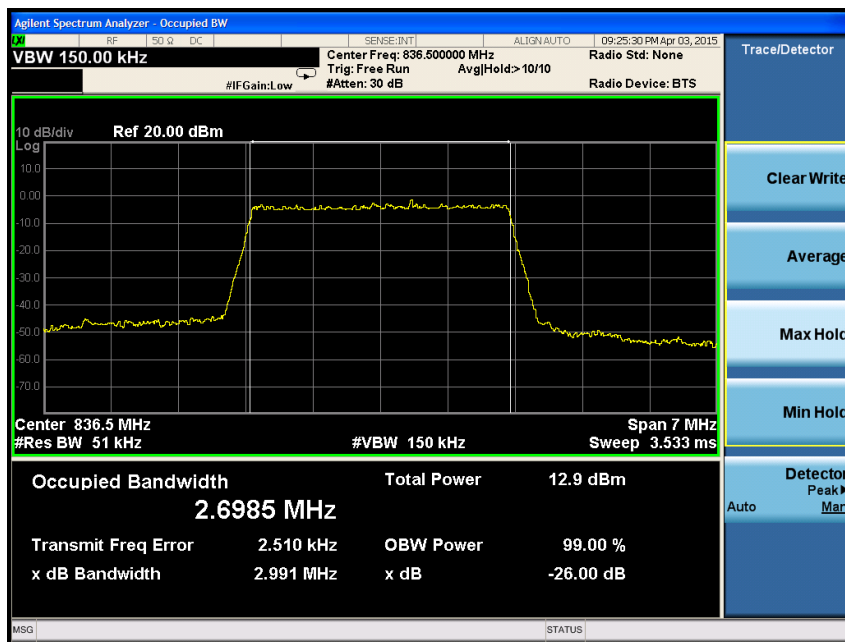

The results shown in this test report refer only to the sample(s) tested unless otherwise stated. This test report cannot be reproduced, except in full, without prior written permission of the Company.

High Channel

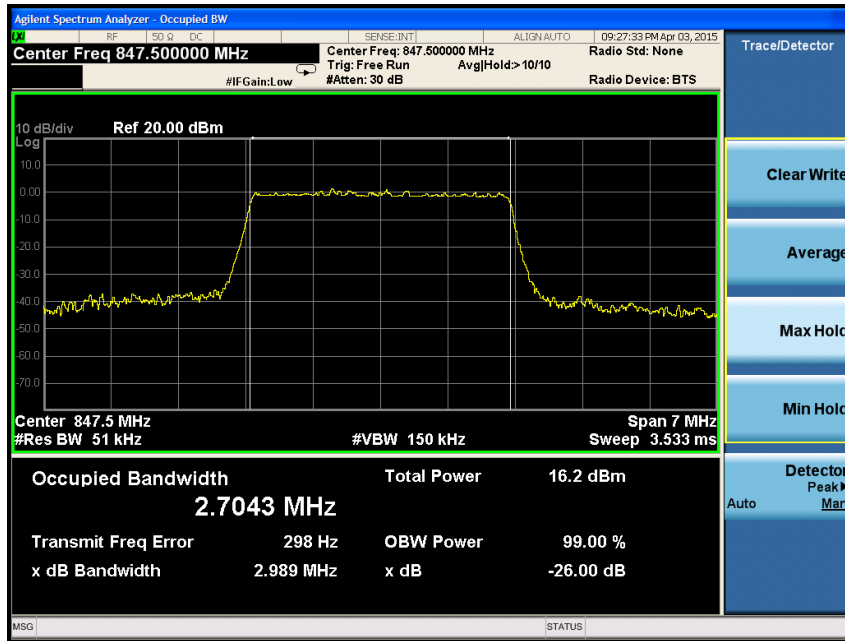

The results shown in this test report refer only to the sample(s) tested unless otherwise stated. This test report cannot be reproduced, except in full, without prior written permission of the Company.

LTE band 5 (3 MHz – 16QAM_RB 15)

Low Channel

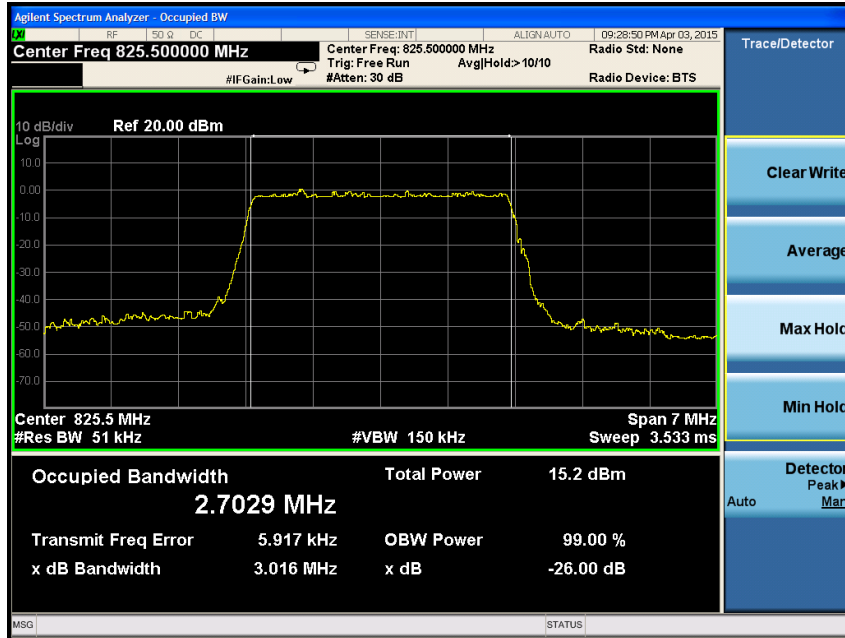

Middle Channel

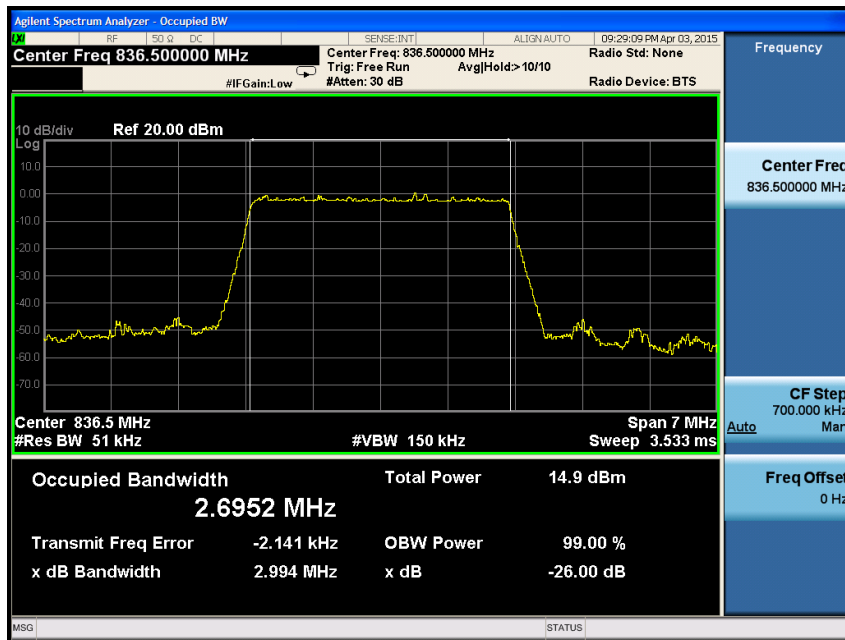

The results shown in this test report refer only to the sample(s) tested unless otherwise stated. This test report cannot be reproduced, except in full, without prior written permission of the Company.

High Channel

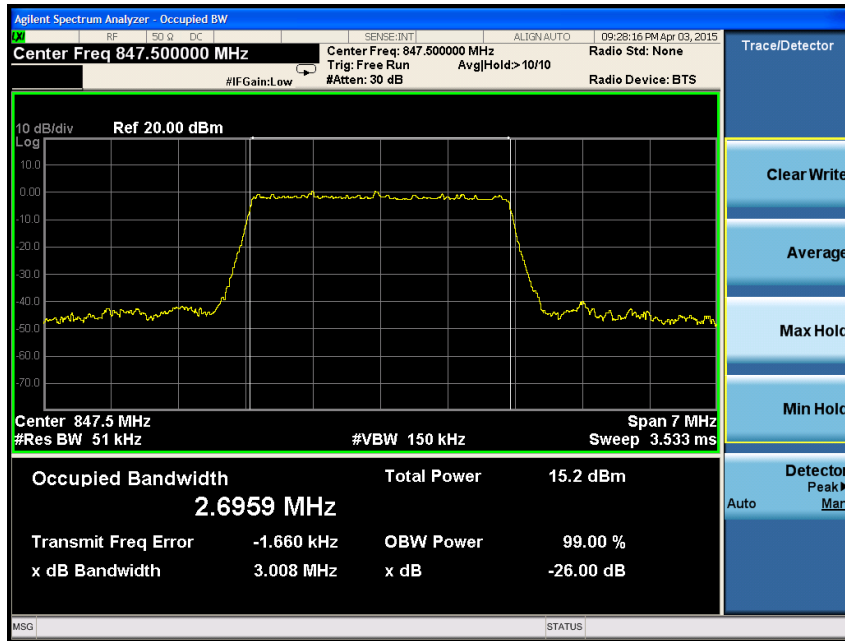

The results shown in this test report refer only to the sample(s) tested unless otherwise stated. This test report cannot be reproduced, except in full, without prior written permission of the Company.

LTE band 5 (5 MHz – QPSK_RB 25)

Low Channel

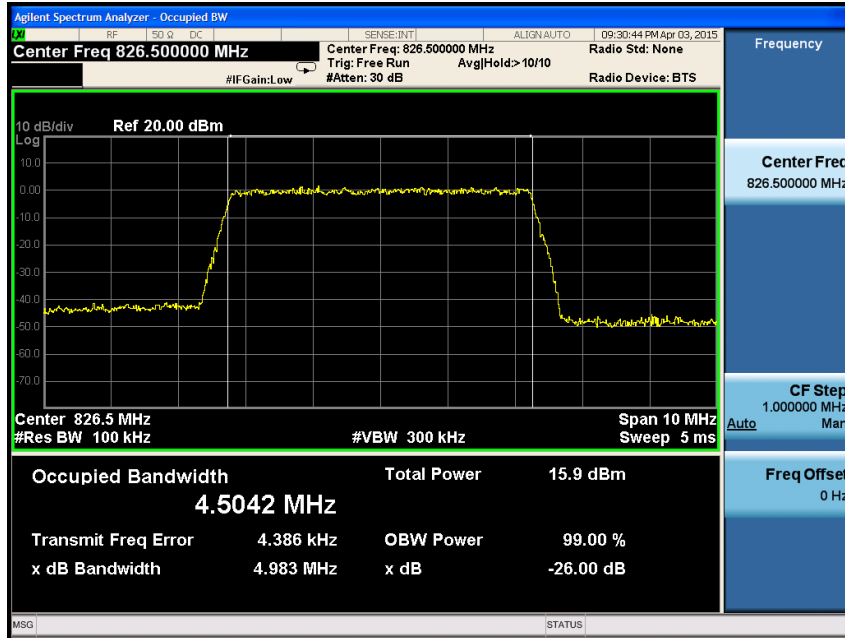

Middle Channel

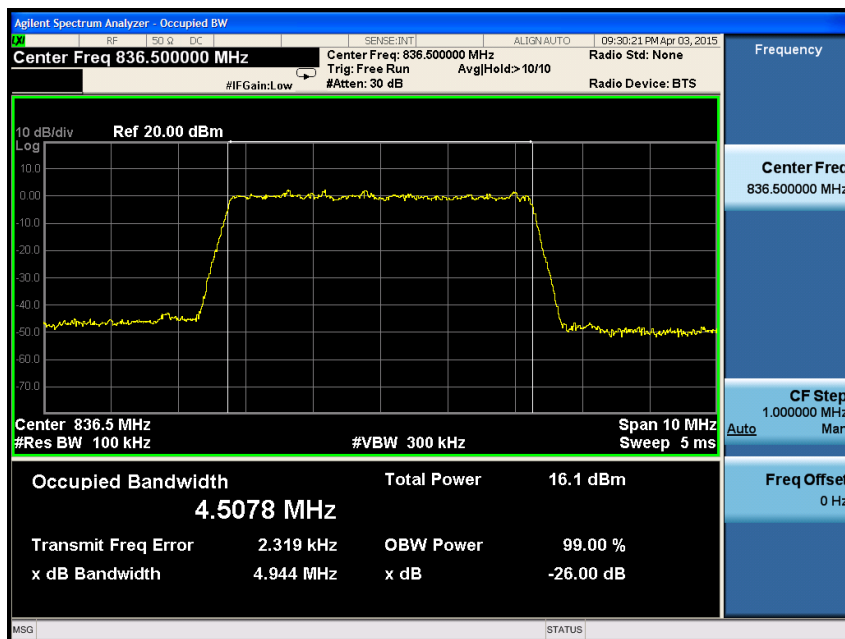

The results shown in this test report refer only to the sample(s) tested unless otherwise stated. This test report cannot be reproduced, except in full, without prior written permission of the Company.

High Channel

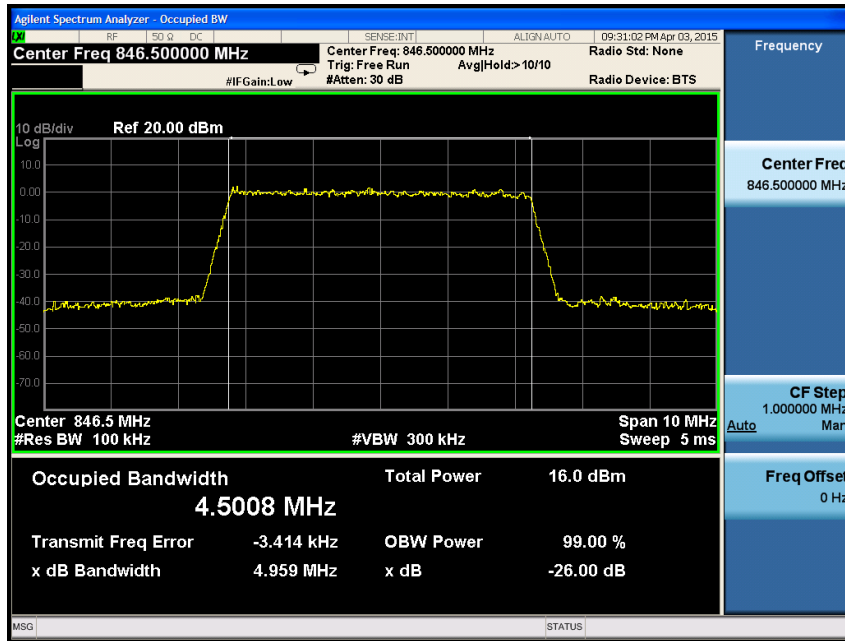

The results shown in this test report refer only to the sample(s) tested unless otherwise stated. This test report cannot be reproduced, except in full, without prior written permission of the Company.

LTE band 5 (5 MHz – 16QAM_RB 25)

Low Channel

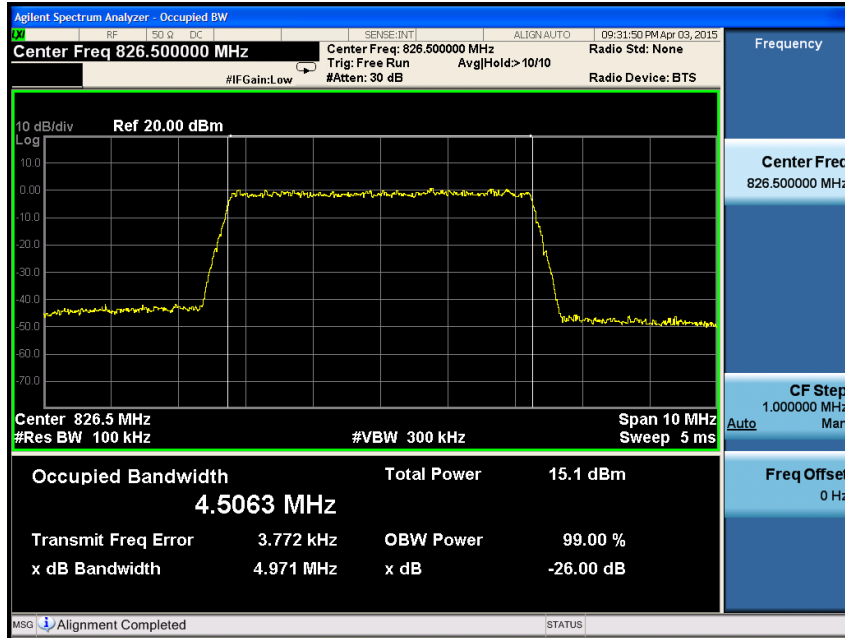

Middle Channel

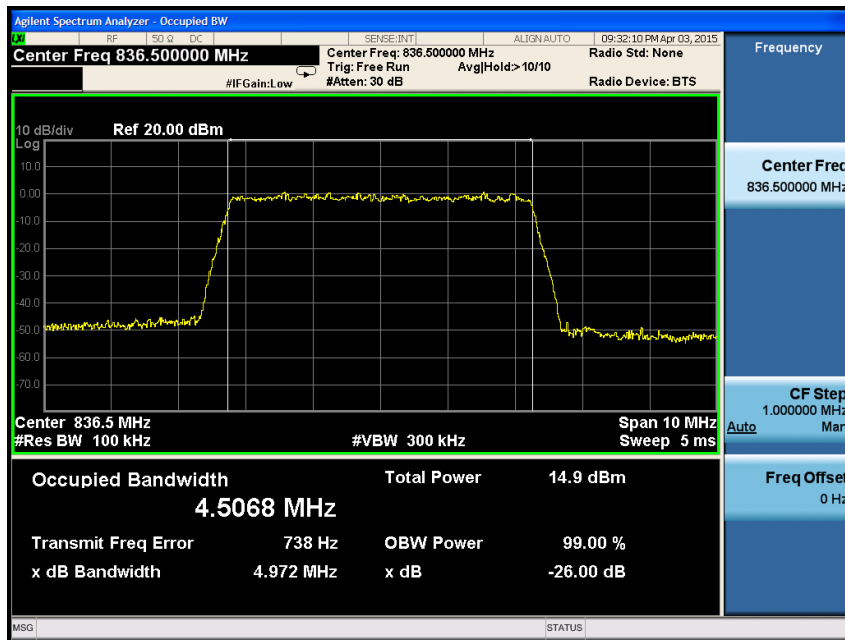

The results shown in this test report refer only to the sample(s) tested unless otherwise stated. This test report cannot be reproduced, except in full, without prior written permission of the Company.

High Channel

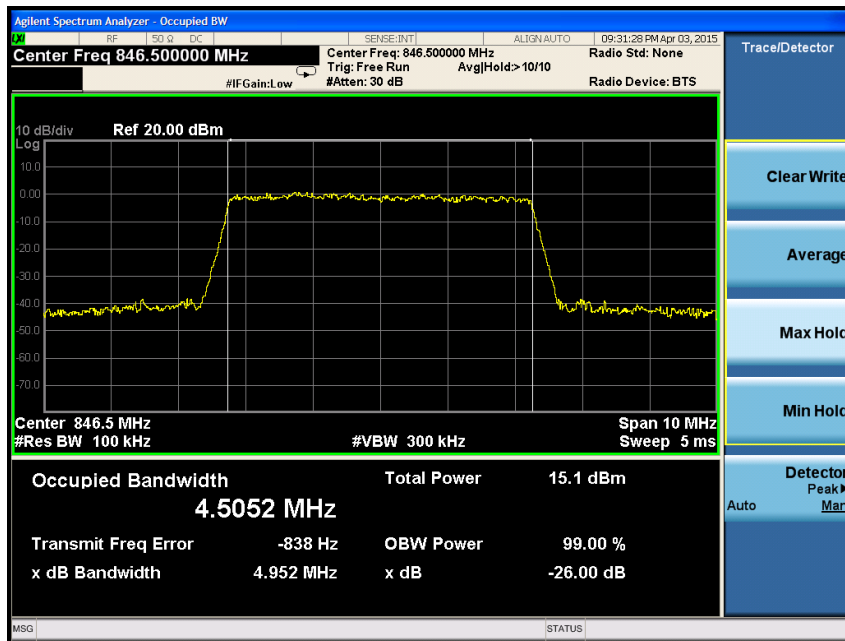

The results shown in this test report refer only to the sample(s) tested unless otherwise stated. This test report cannot be reproduced, except in full, without prior written permission of the Company.

LTE band 5 (10 MHz – QPSK_RB 50)

Low Channel

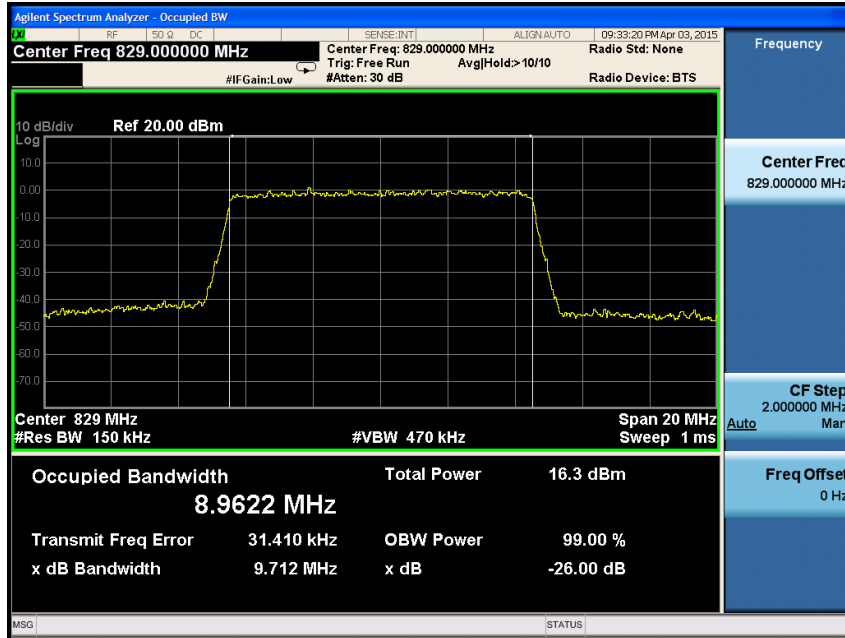

Middle Channel

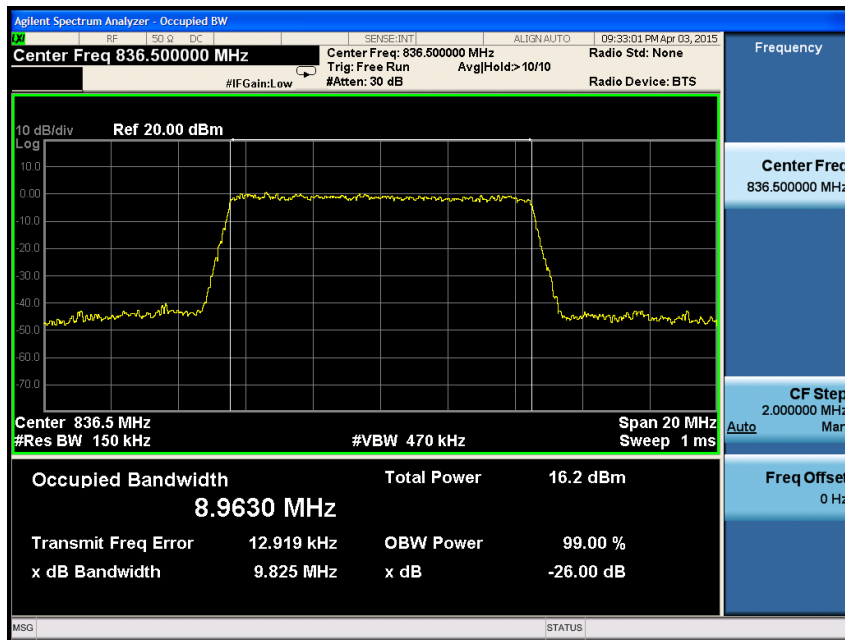

The results shown in this test report refer only to the sample(s) tested unless otherwise stated. This test report cannot be reproduced, except in full, without prior written permission of the Company.

High Channel

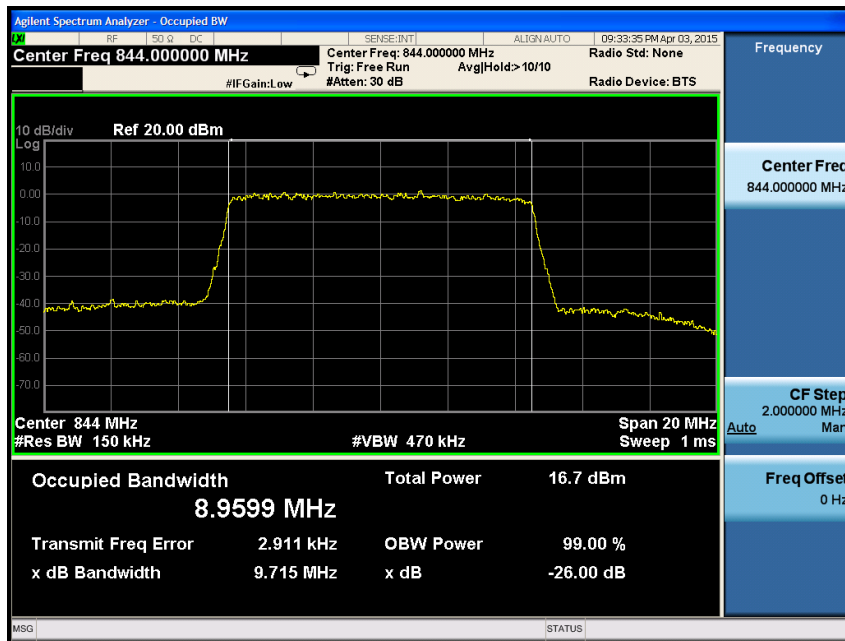

The results shown in this test report refer only to the sample(s) tested unless otherwise stated. This test report cannot be reproduced, except in full, without prior written permission of the Company.

LTE band 5 (10 MHz – 16QAM_RB 50)

Low Channel

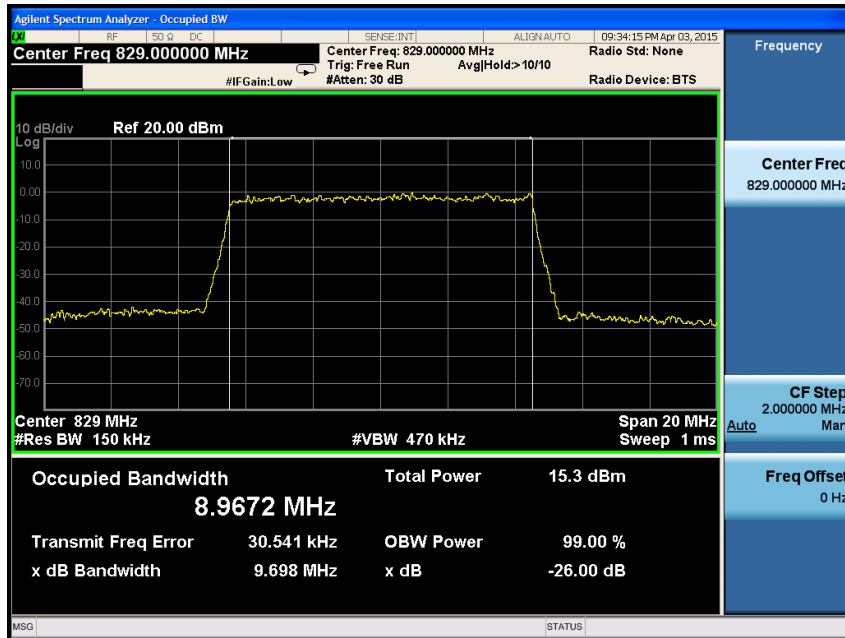

Middle Channel

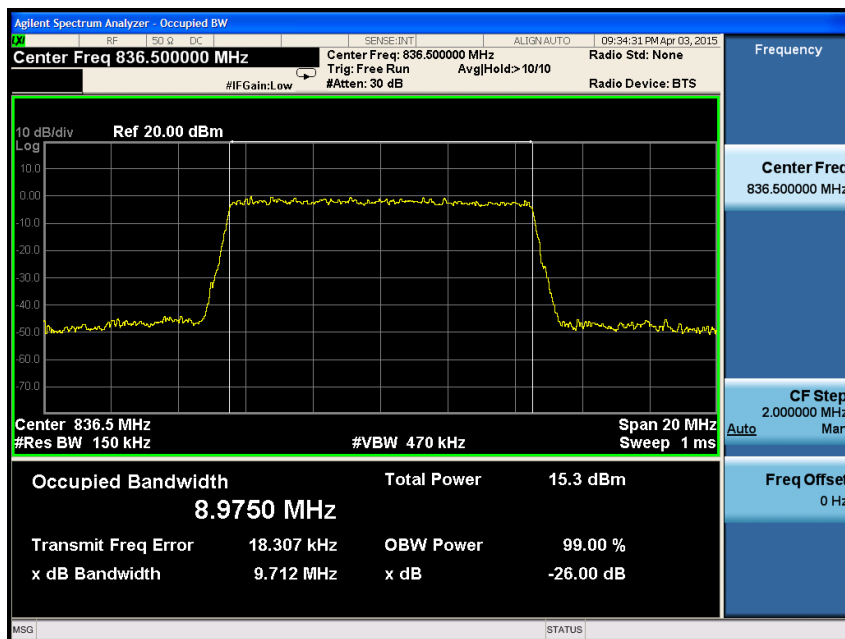

The results shown in this test report refer only to the sample(s) tested unless otherwise stated. This test report cannot be reproduced, except in full, without prior written permission of the Company.

High Channel

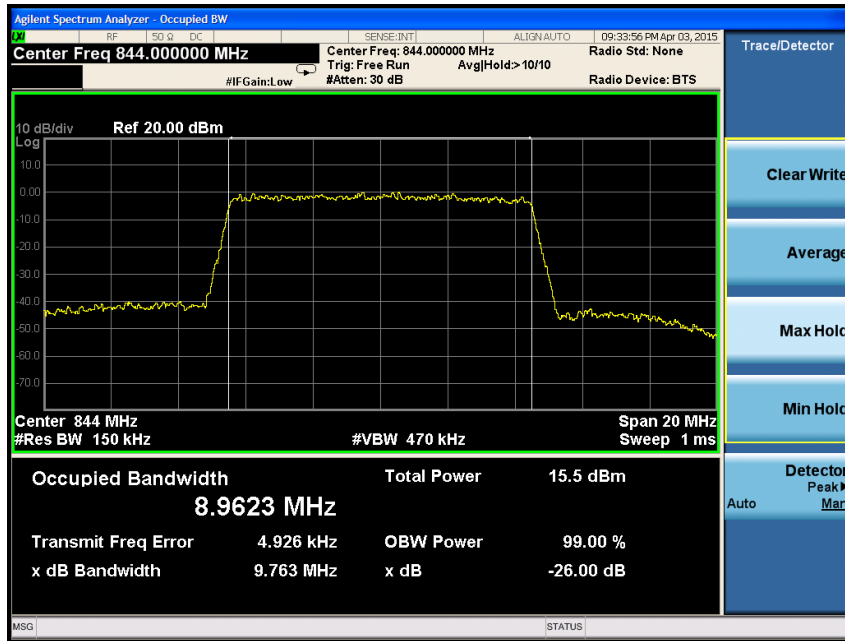

The results shown in this test report refer only to the sample(s) tested unless otherwise stated. This test report cannot be reproduced, except in full, without prior written permission of the Company.

LTE band 17 (5 MHz – QPSK_RB 25)

Low Channel

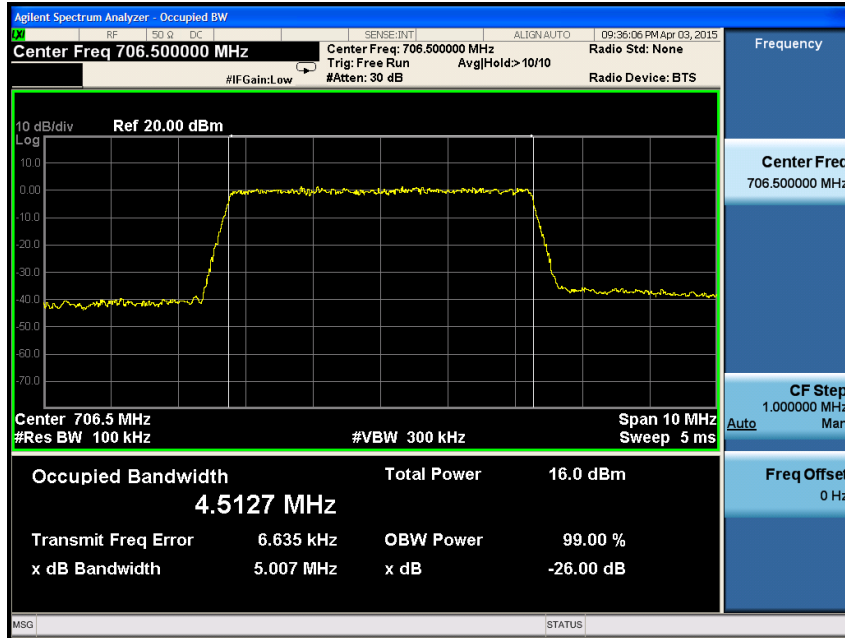

Middle Channel

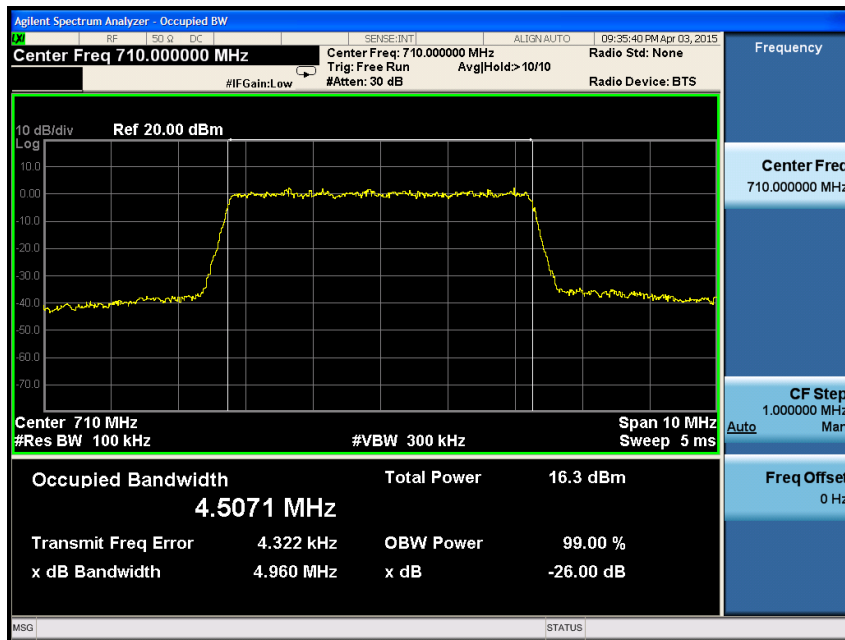

The results shown in this test report refer only to the sample(s) tested unless otherwise stated. This test report cannot be reproduced, except in full, without prior written permission of the Company.

High Channel

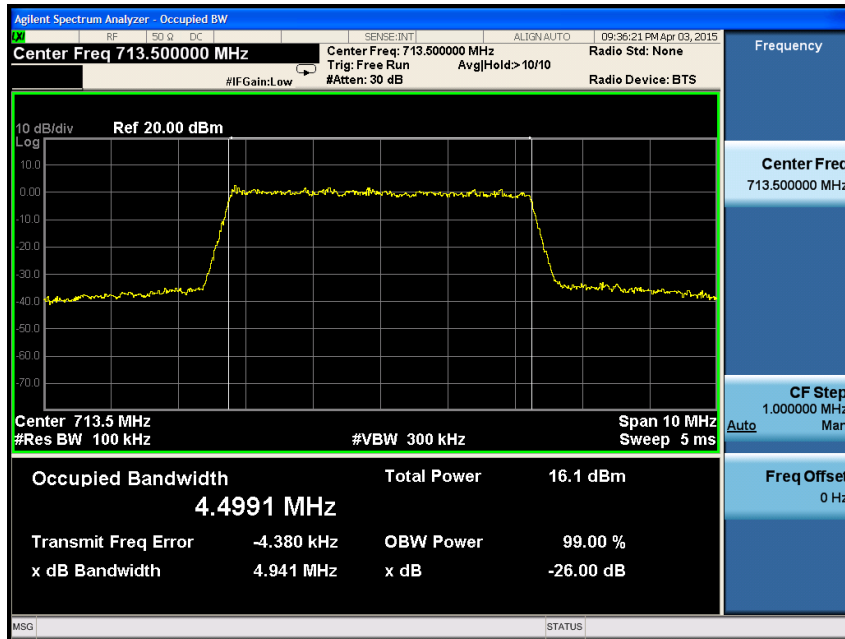

The results shown in this test report refer only to the sample(s) tested unless otherwise stated. This test report cannot be reproduced, except in full, without prior written permission of the Company.

LTE band 17 (5 MHz – 16QAM_RB 25)

Low Channel

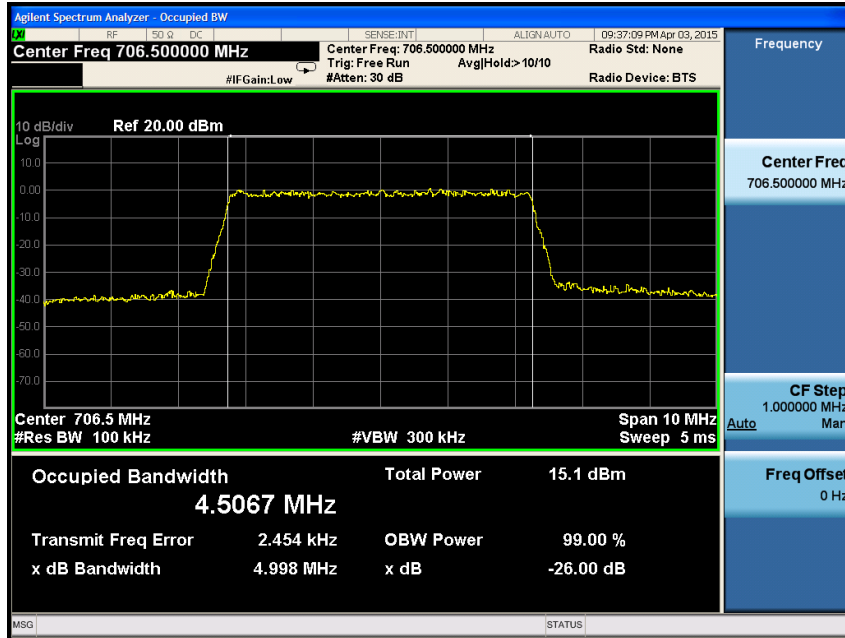

Middle Channel

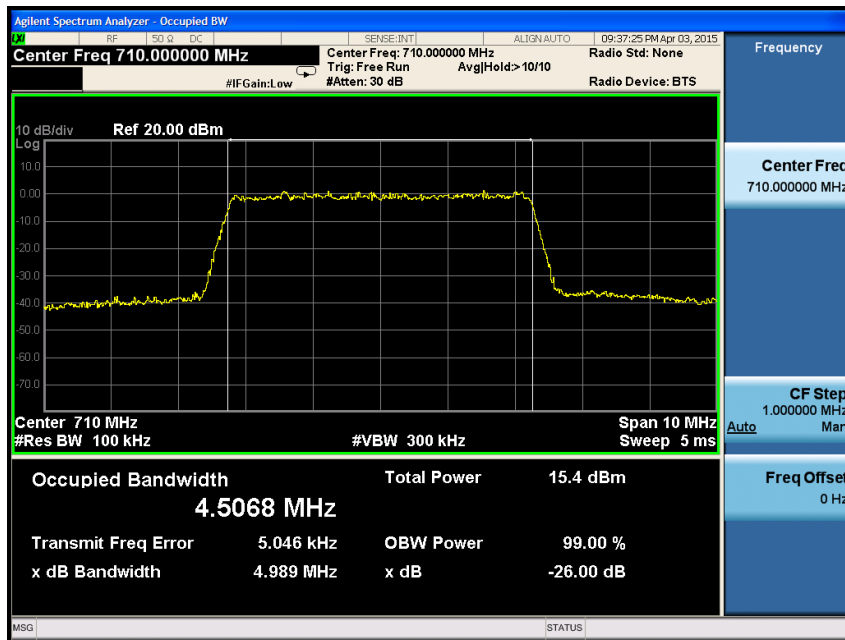

The results shown in this test report refer only to the sample(s) tested unless otherwise stated. This test report cannot be reproduced, except in full, without prior written permission of the Company.

High Channel

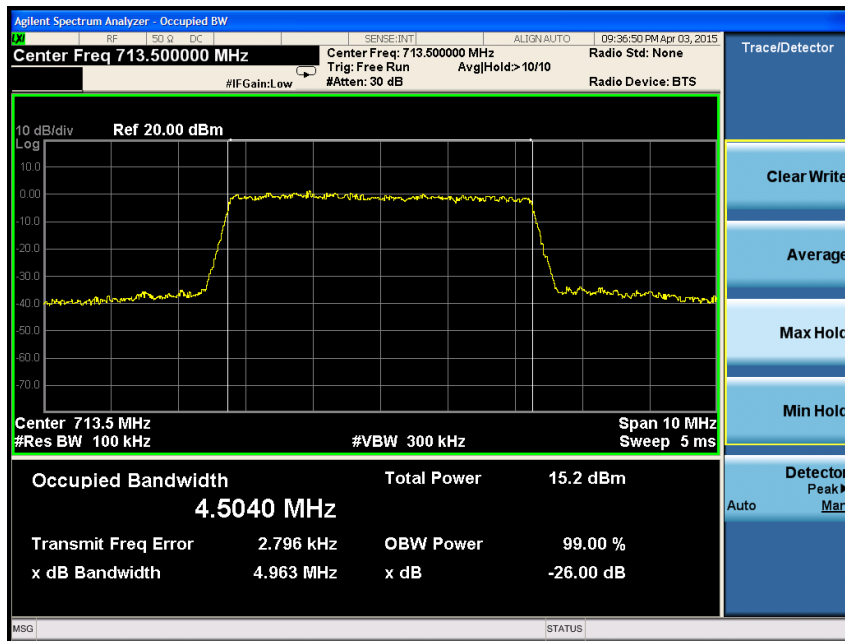

The results shown in this test report refer only to the sample(s) tested unless otherwise stated. This test report cannot be reproduced, except in full, without prior written permission of the Company.

LTE band 17 (10 MHz – QPSK_RB 50)

Low Channel

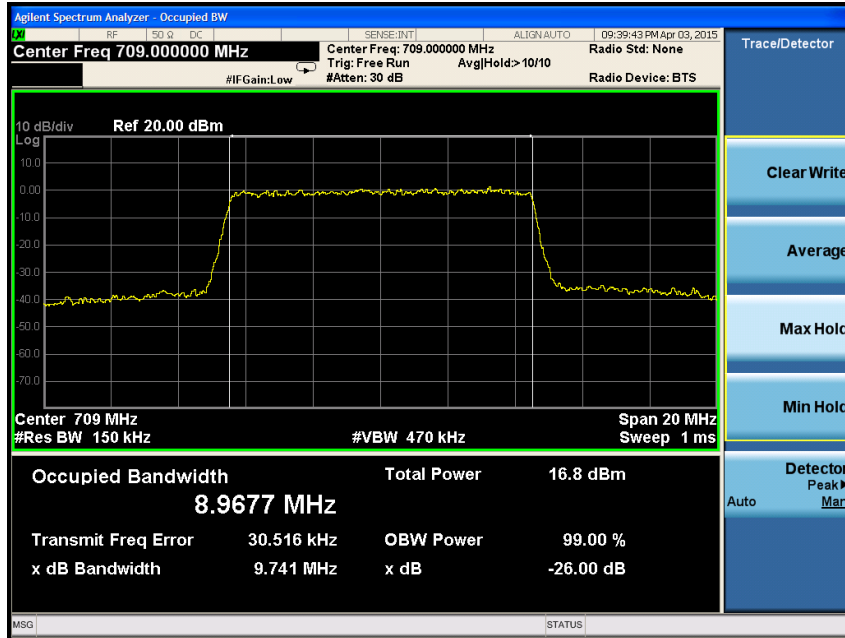

Middle Channel

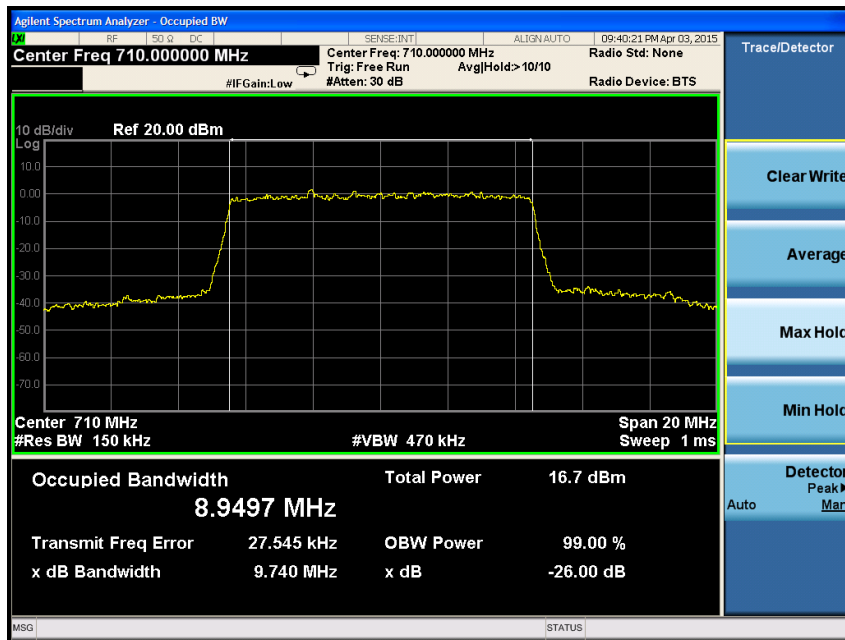

The results shown in this test report refer only to the sample(s) tested unless otherwise stated. This test report cannot be reproduced, except in full, without prior written permission of the Company.

High Channel

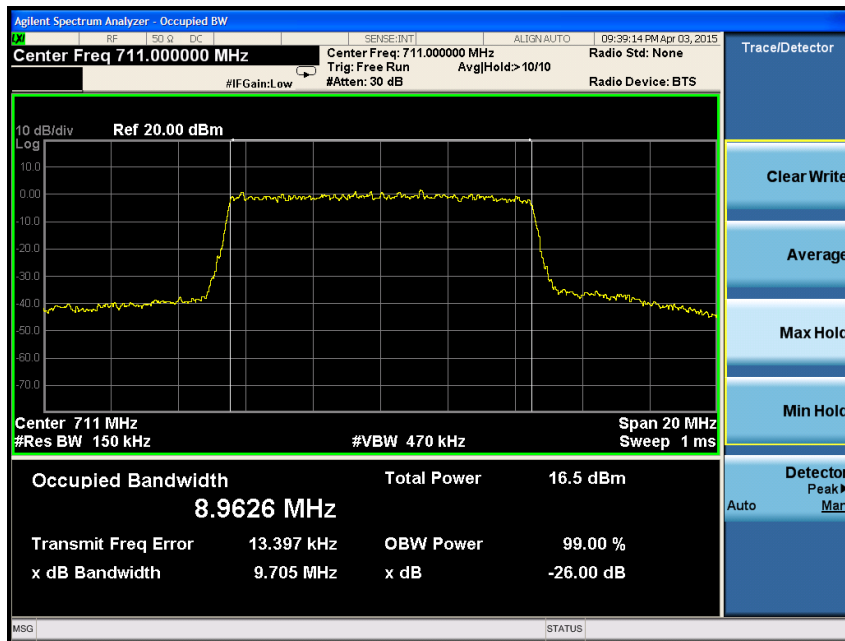

The results shown in this test report refer only to the sample(s) tested unless otherwise stated. This test report cannot be reproduced, except in full, without prior written permission of the Company.

LTE band 17 (10 MHz – 16QAM_RB 50)

Low Channel

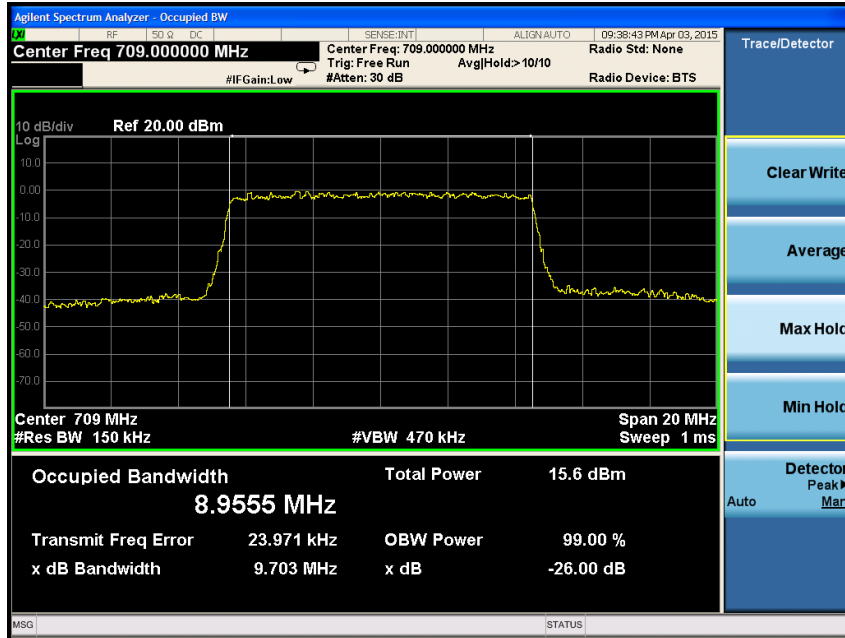

Middle Channel

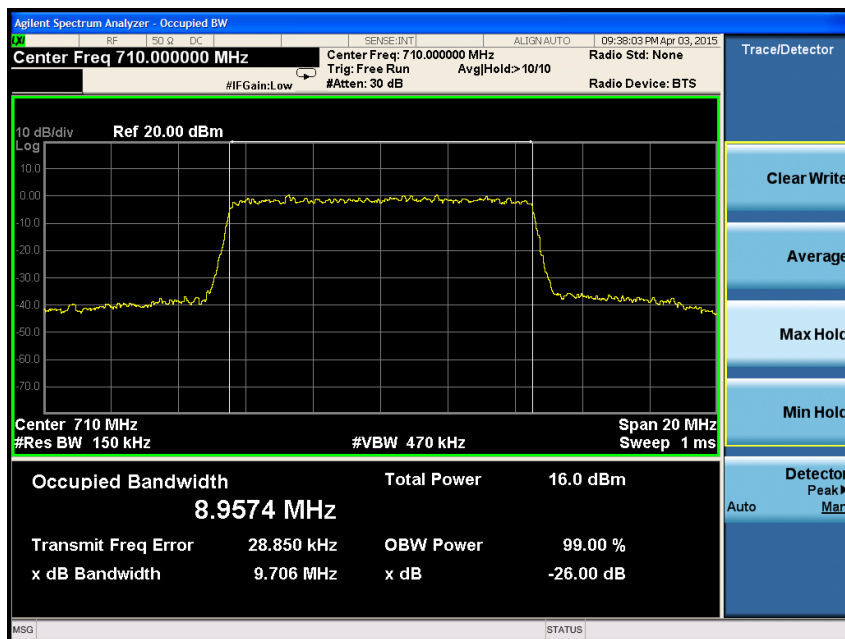

The results shown in this test report refer only to the sample(s) tested unless otherwise stated. This test report cannot be reproduced, except in full, without prior written permission of the Company.

High Channel

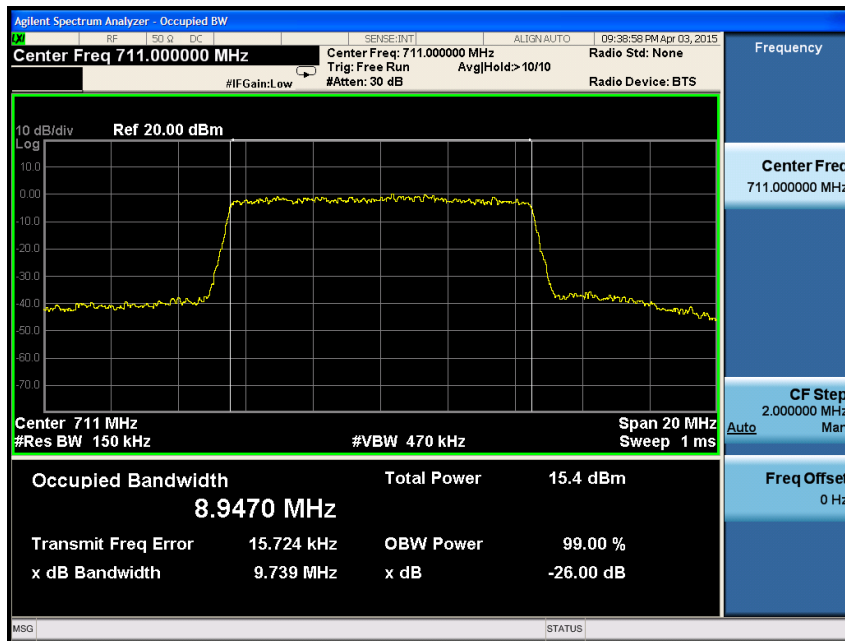

The results shown in this test report refer only to the sample(s) tested unless otherwise stated. This test report cannot be reproduced, except in full, without prior written permission of the Company.

LTE band 41 (5 MHz – QPSK_RB 25)

Low Channel

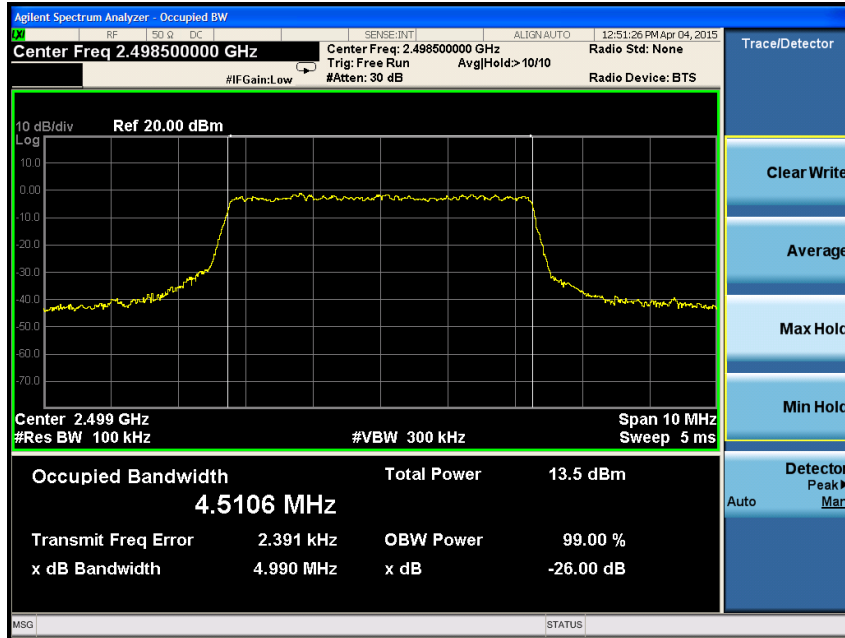

Middle Channel

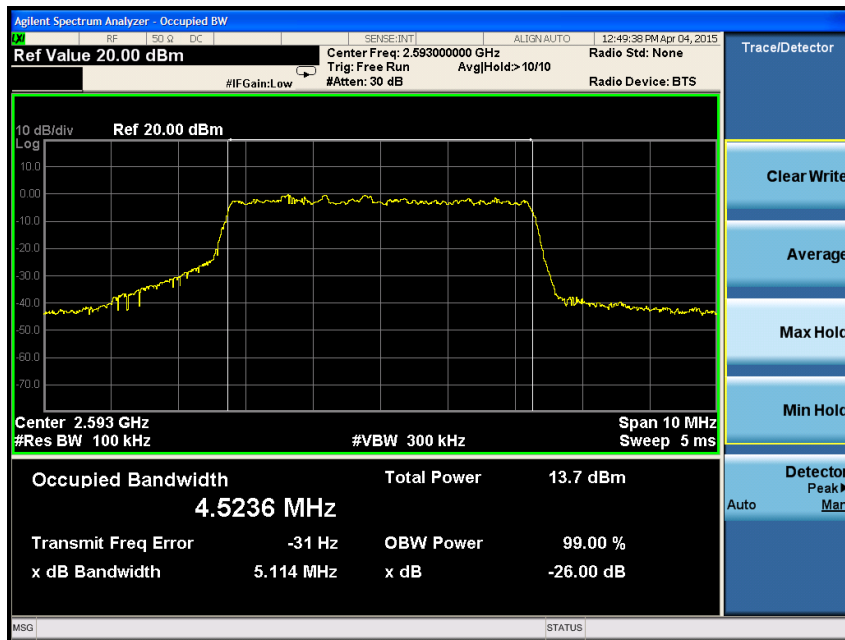

The results shown in this test report refer only to the sample(s) tested unless otherwise stated. This test report cannot be reproduced, except in full, without prior written permission of the Company.

High Channel

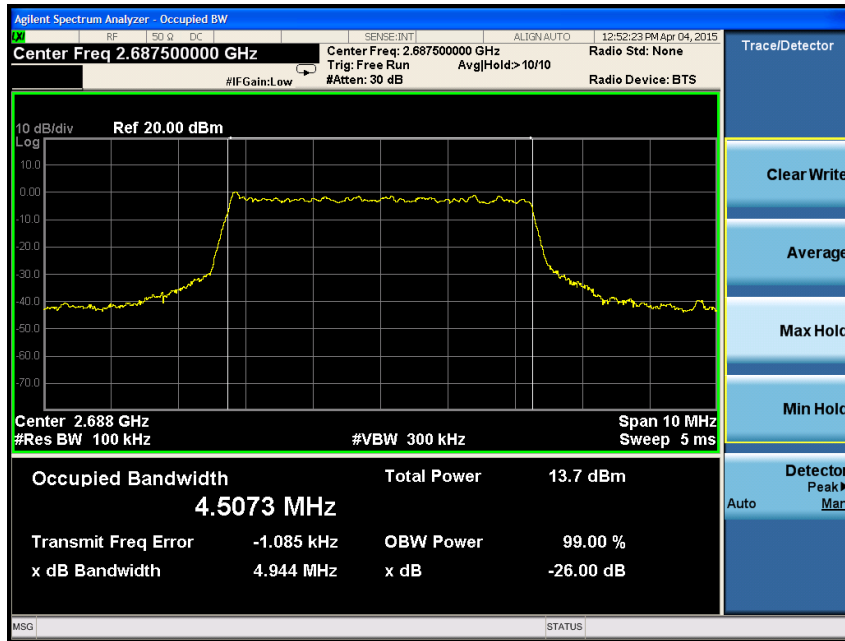

The results shown in this test report refer only to the sample(s) tested unless otherwise stated. This test report cannot be reproduced, except in full, without prior written permission of the Company.

LTE band 41 (5 MHz – 16QAM_RB 25)

Low Channel

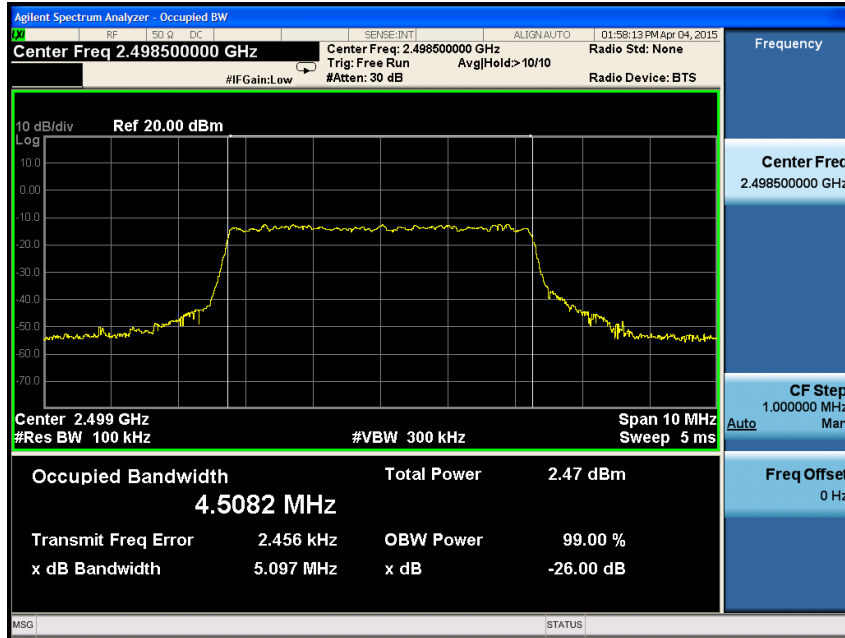

Middle Channel

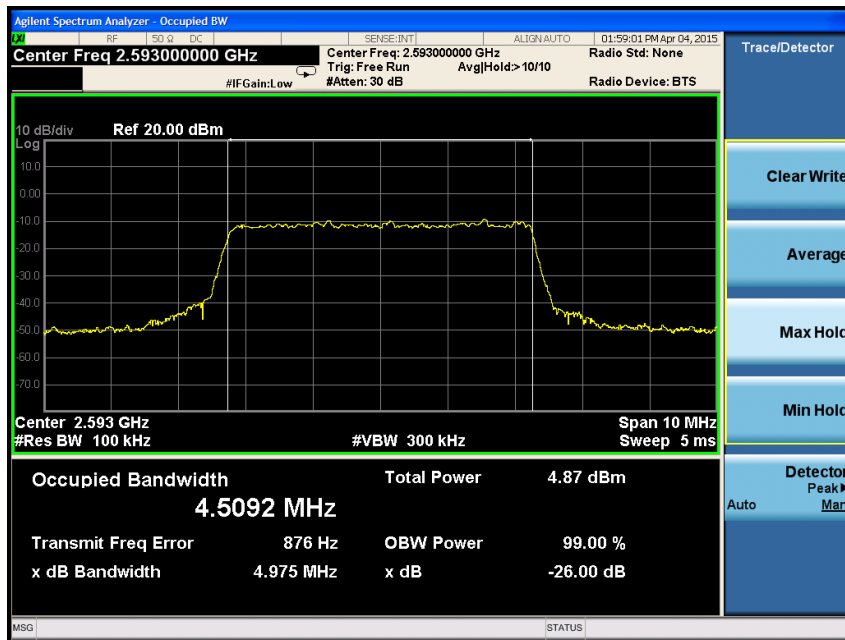

The results shown in this test report refer only to the sample(s) tested unless otherwise stated. This test report cannot be reproduced, except in full, without prior written permission of the Company.

High Channel

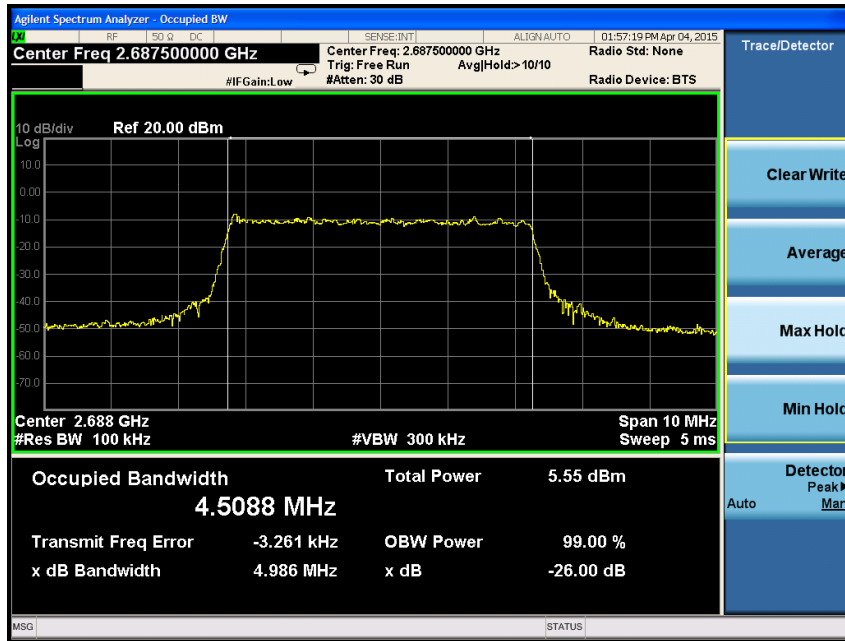

The results shown in this test report refer only to the sample(s) tested unless otherwise stated. This test report cannot be reproduced, except in full, without prior written permission of the Company.

LTE band 41 (10 MHz – QPSK_RB 50)

Low Channel

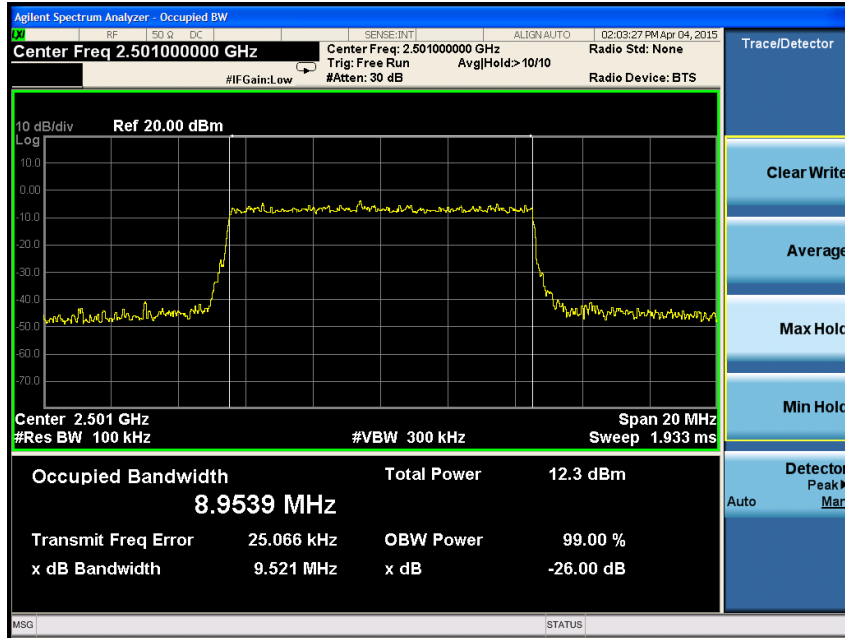

Middle Channel

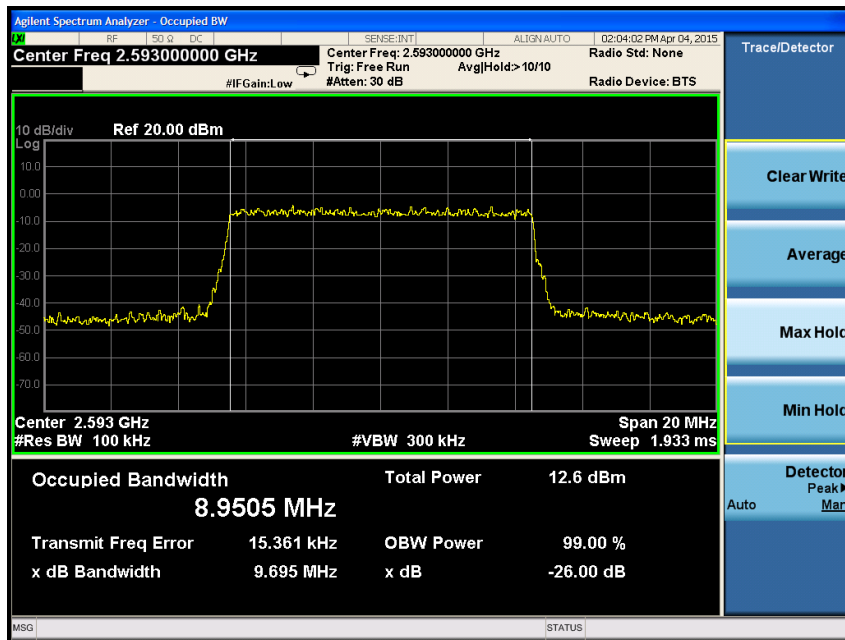

The results shown in this test report refer only to the sample(s) tested unless otherwise stated. This test report cannot be reproduced, except in full, without prior written permission of the Company.

High Channel

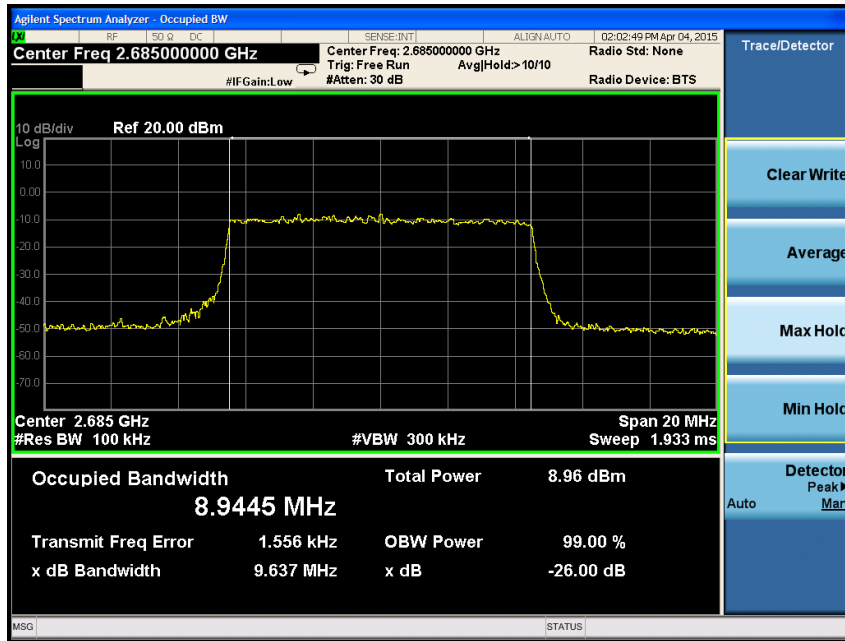

The results shown in this test report refer only to the sample(s) tested unless otherwise stated. This test report cannot be reproduced, except in full, without prior written permission of the Company.

LTE band 41 (10 MHz – 16QAM_RB 50)

Low Channel

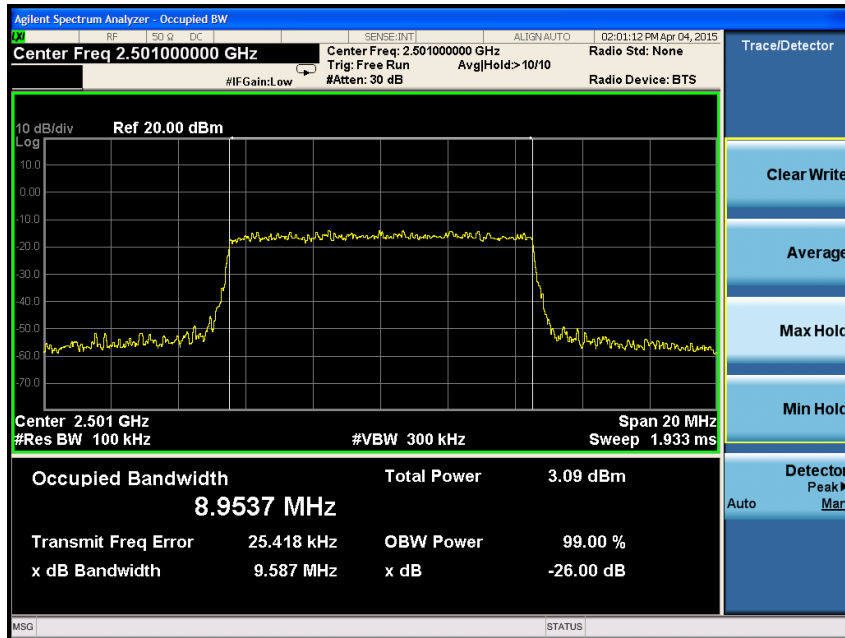

Middle Channel

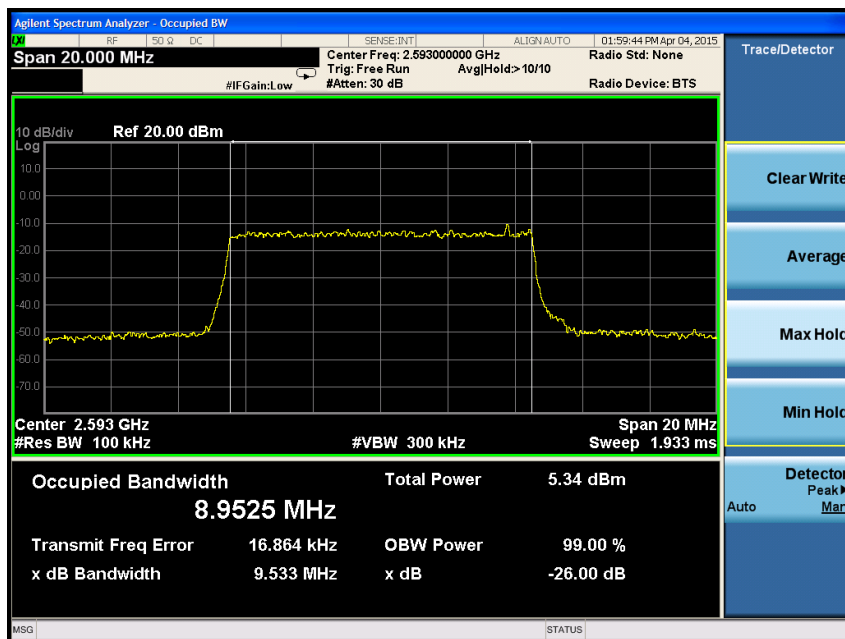

The results shown in this test report refer only to the sample(s) tested unless otherwise stated. This test report cannot be reproduced, except in full, without prior written permission of the Company.

High Channel

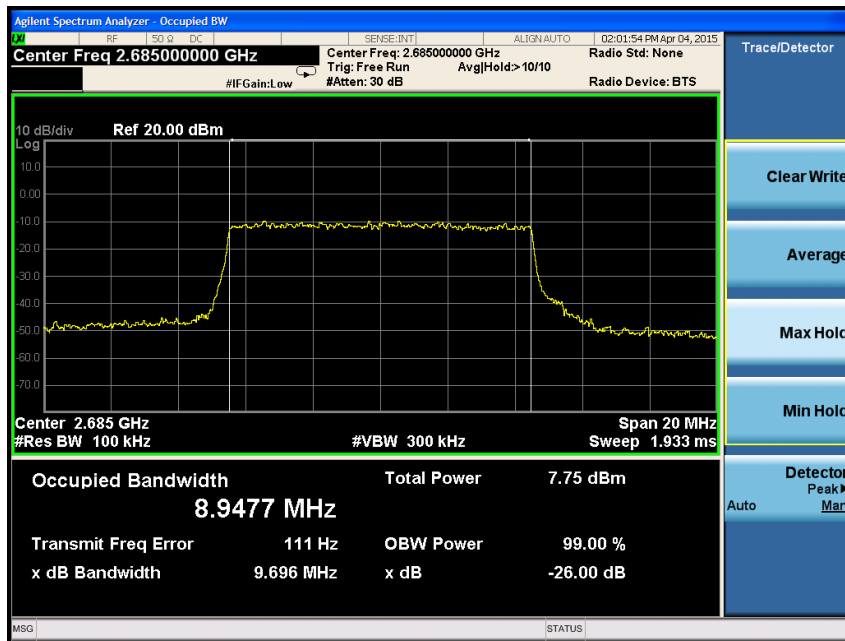

The results shown in this test report refer only to the sample(s) tested unless otherwise stated. This test report cannot be reproduced, except in full, without prior written permission of the Company.

LTE band 41 (15 MHz – QPSK_RB 75)

Low Channel

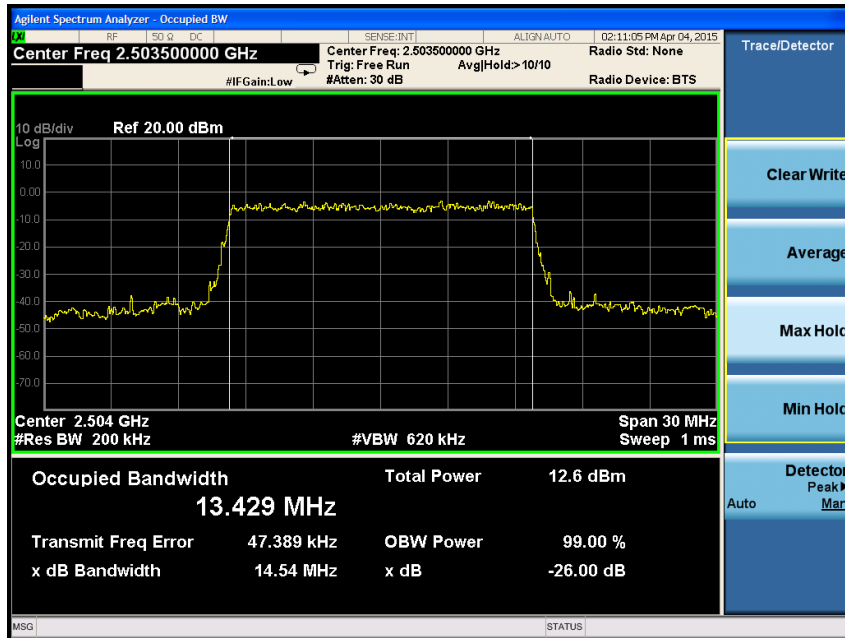

Middle Channel

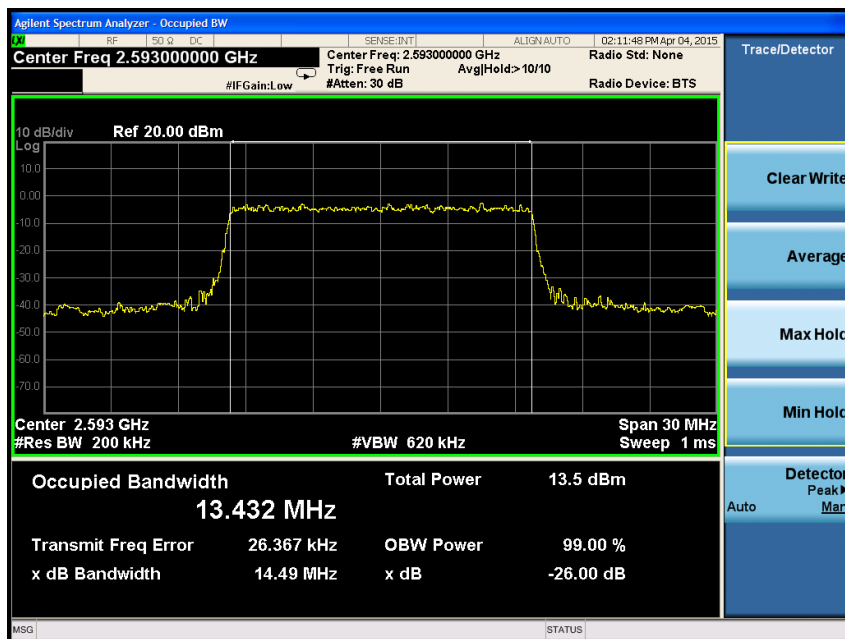

The results shown in this test report refer only to the sample(s) tested unless otherwise stated. This test report cannot be reproduced, except in full, without prior written permission of the Company.

High Channel

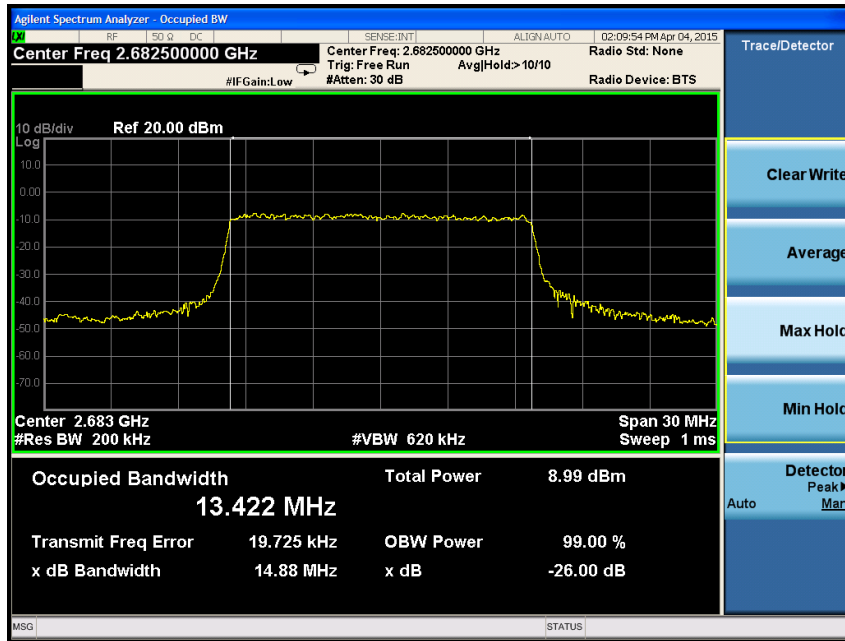

The results shown in this test report refer only to the sample(s) tested unless otherwise stated. This test report cannot be reproduced, except in full, without prior written permission of the Company.

LTE band 41 (15 MHz – 16QAM_RB 75)

Low Channel

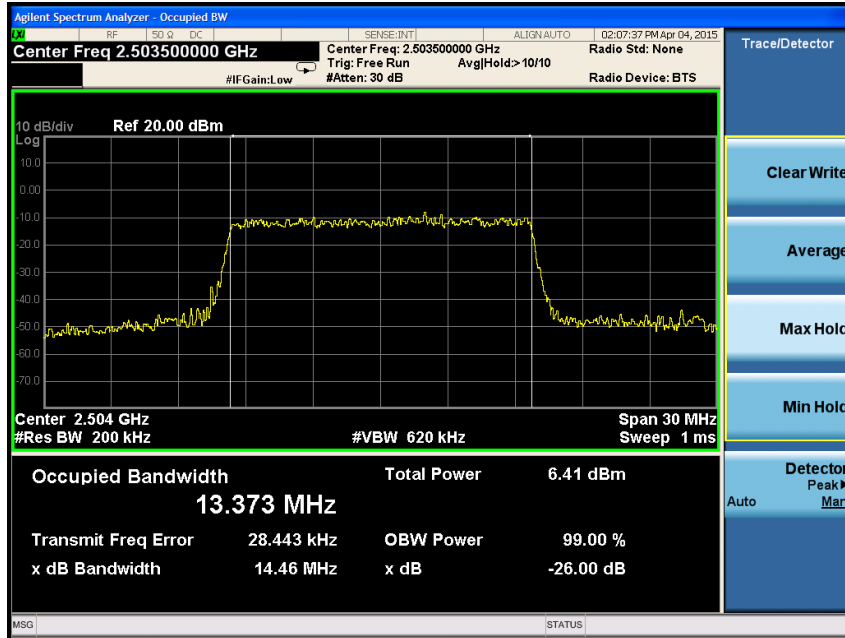

Middle Channel

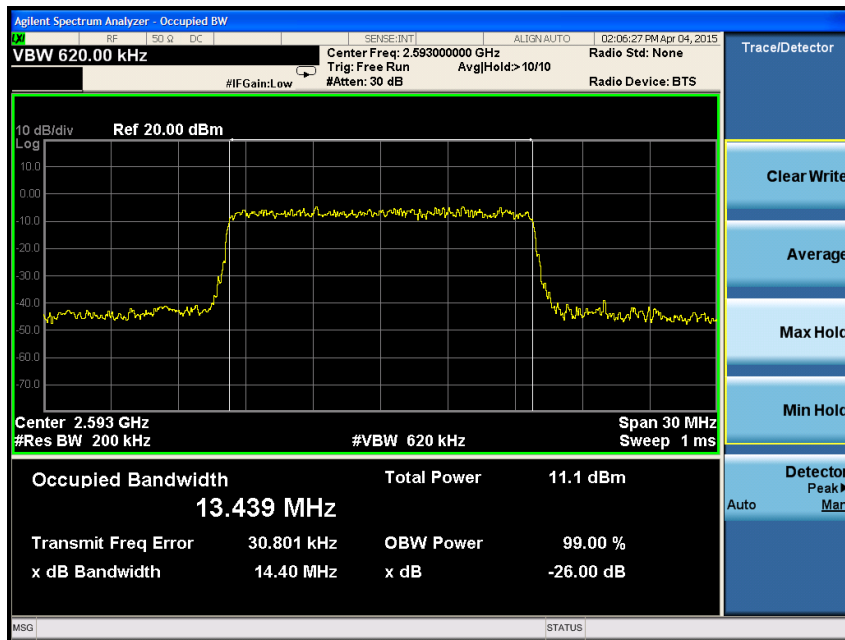

The results shown in this test report refer only to the sample(s) tested unless otherwise stated. This test report cannot be reproduced, except in full, without prior written permission of the Company.

High Channel

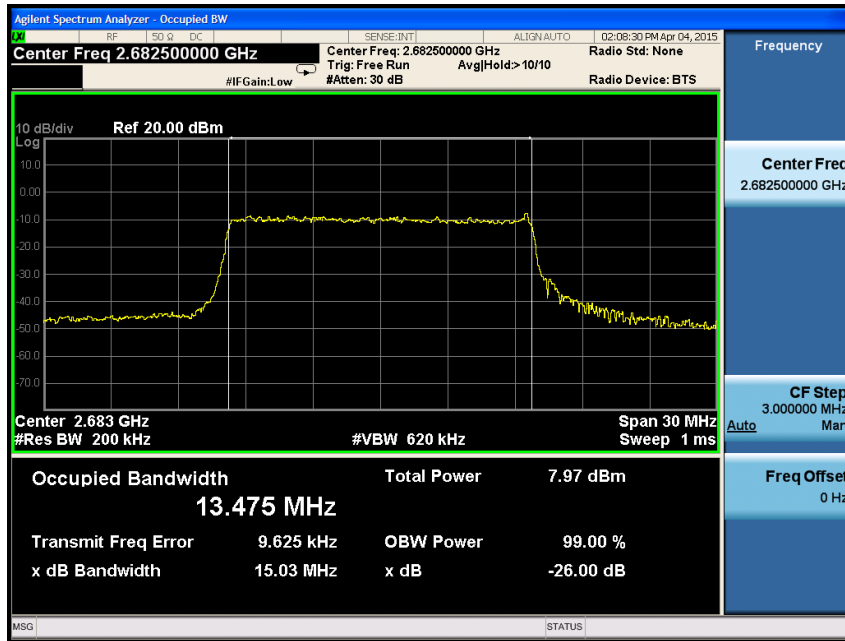

The results shown in this test report refer only to the sample(s) tested unless otherwise stated. This test report cannot be reproduced, except in full, without prior written permission of the Company.

LTE band 41 (20 MHz – QPSK_RB 100)

Low Channel

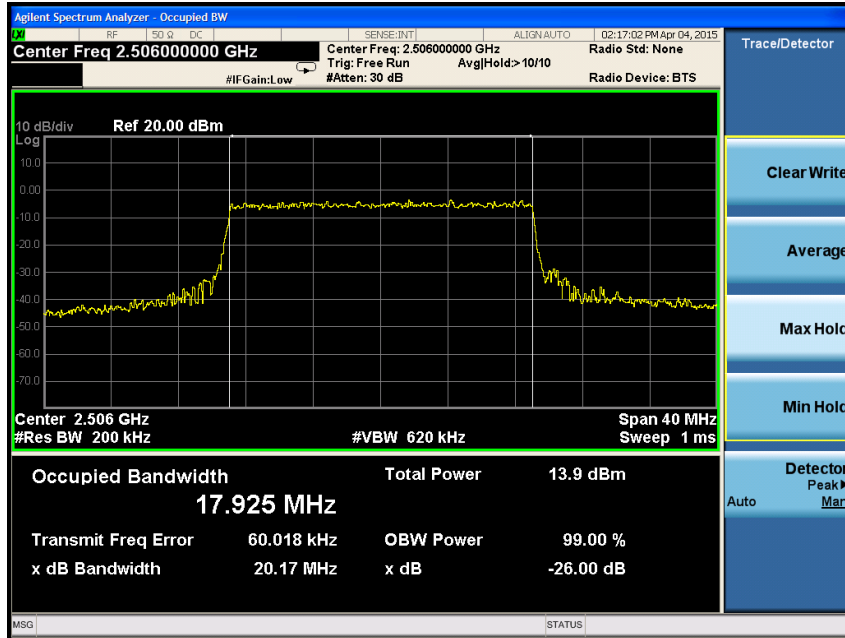

Middle Channel

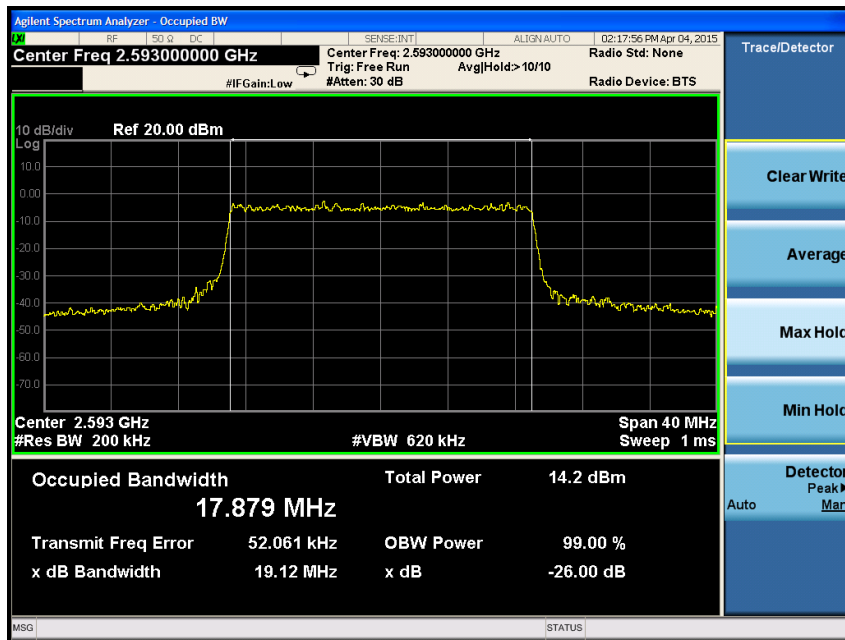

The results shown in this test report refer only to the sample(s) tested unless otherwise stated. This test report cannot be reproduced, except in full, without prior written permission of the Company.

High Channel

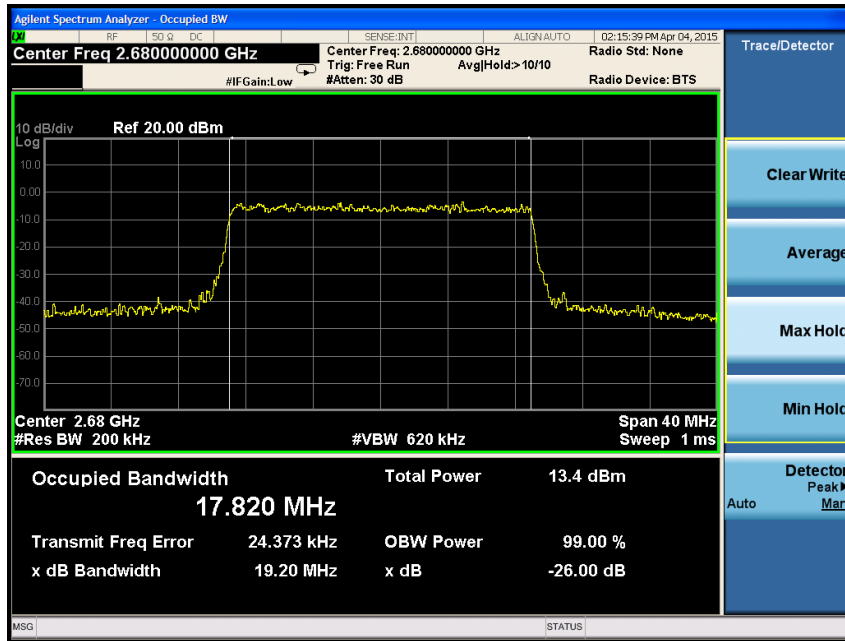

The results shown in this test report refer only to the sample(s) tested unless otherwise stated. This test report cannot be reproduced, except in full, without prior written permission of the Company.

LTE band 41 (20 MHz – 16QAM_RB 100)

Low Channel

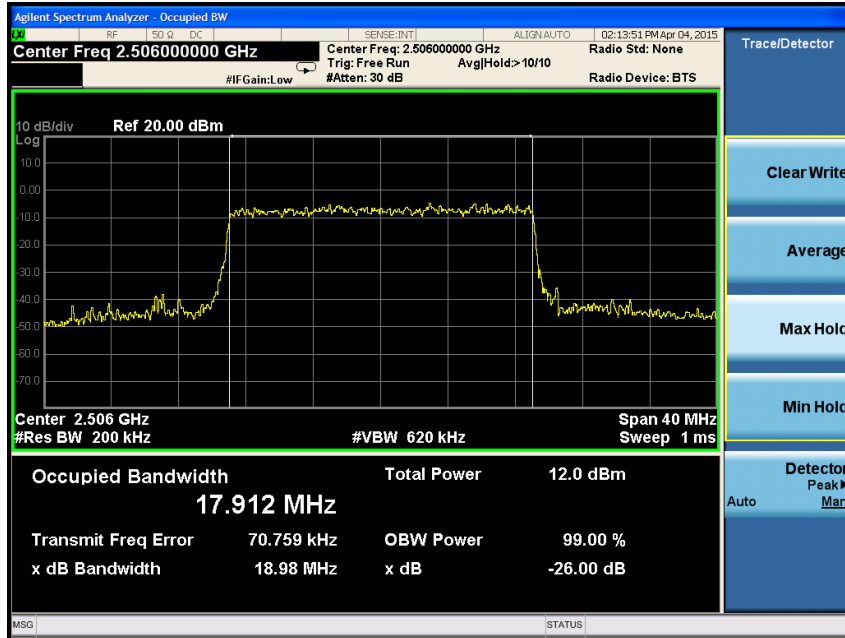

Middle Channel

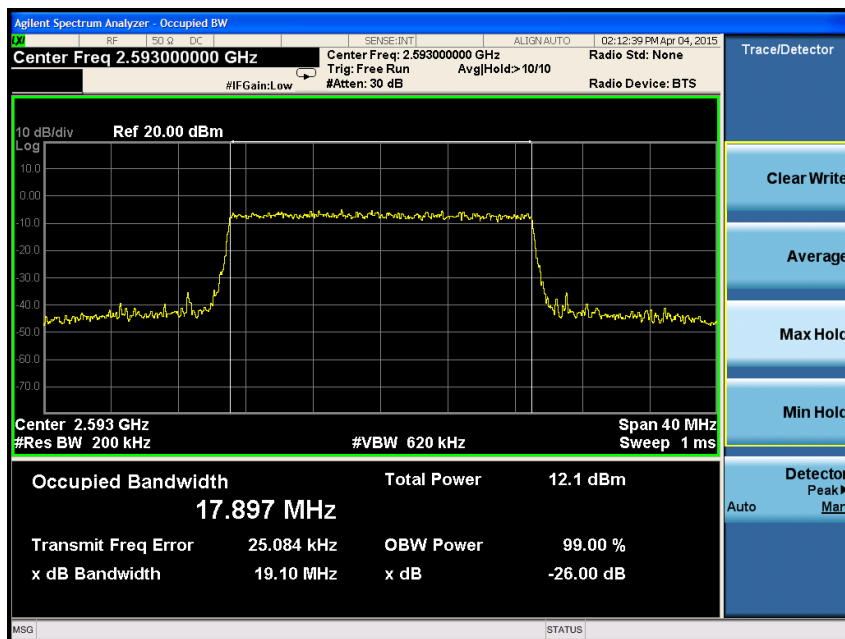

The results shown in this test report refer only to the sample(s) tested unless otherwise stated. This test report cannot be reproduced, except in full, without prior written permission of the Company.

High Channel

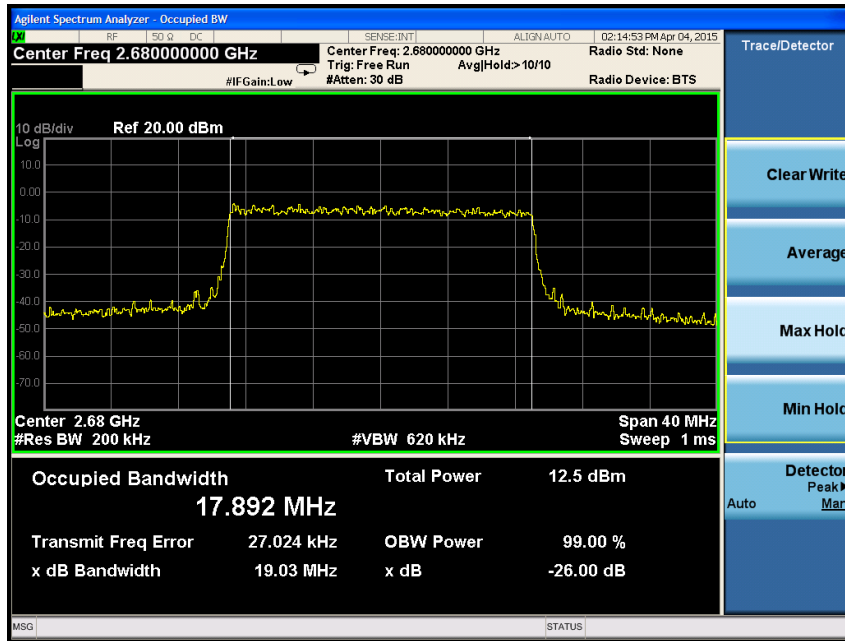

The results shown in this test report refer only to the sample(s) tested unless otherwise stated. This test report cannot be reproduced, except in full, without prior written permission of the Company.

4. Peak-Average Ratio

4.1. Limit

§24.232(d) Power measurements for transmissions by stations authorized under this section may be made either in accordance with a Commission-approved average power technique or in compliance with paragraph (e) of this section. In both instances, equipment employed must be authorized in accordance with the provisions of §24.51. In measuring transmissions in this band using an average power technique, the peak-to-average ratio (PAR) of the transmission may not exceed 13 dB.

4.2. Test Procedure

The test follows section 5.7.1 of FCC KDB Publication 971168_v02r02.

1. Refer to instrument's analyzer instruction manual for details on how to use the power statistics/CCDF function.
2. Set resolution/measurement bandwidth \geq signal's occupied bandwidth.
3. Set the number of counts to a value that stabilizes the measured CCDF curve.
4. Set the measurement interval as follows:
 - a) for continuous transmissions, set to 1 ms.
 - b) for burst transmissions, employ an external trigger that is synchronized with the EUT burst timing sequence, or use the internal burst trigger with a trigger level that allows the burst to stabilize and set the measurement interval to a time that is less than or equal to the burst duration.
5. Record the maximum PAPR level associated with a probability of 0.1%.

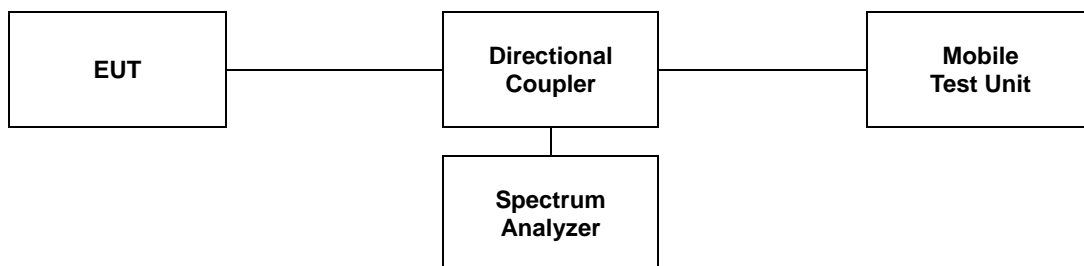

The results shown in this test report refer only to the sample(s) tested unless otherwise stated. This test report cannot be reproduced, except in full, without prior written permission of the Company.

4.3 Test Results

Ambient temperature : (24 ± 1) °C
 Relative humidity : 47 % R.H.

Please refer to the following plots.

Band	Mode	Frequency (MHz)	PAR (dB)
GSM1900	GSM GPRS	1 850.2	2.72
		1 880.0	2.71
		1 909.8	2.75

The results shown in this test report refer only to the sample(s) tested unless otherwise stated. This test report cannot be reproduced, except in full, without prior written permission of the Company.

GSM1900
Low Channel

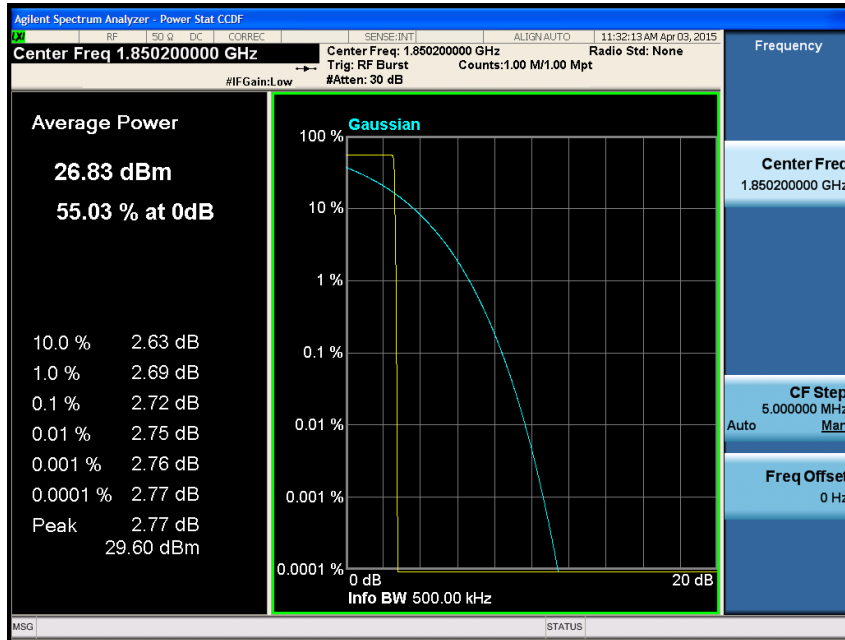

Middle Channel

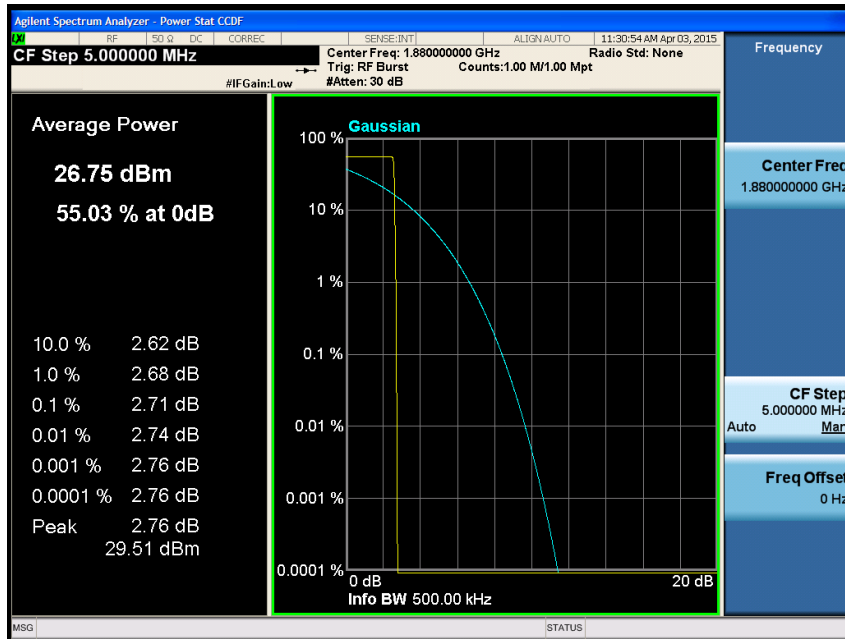

The results shown in this test report refer only to the sample(s) tested unless otherwise stated. This test report cannot be reproduced, except in full, without prior written permission of the Company.

High Channel

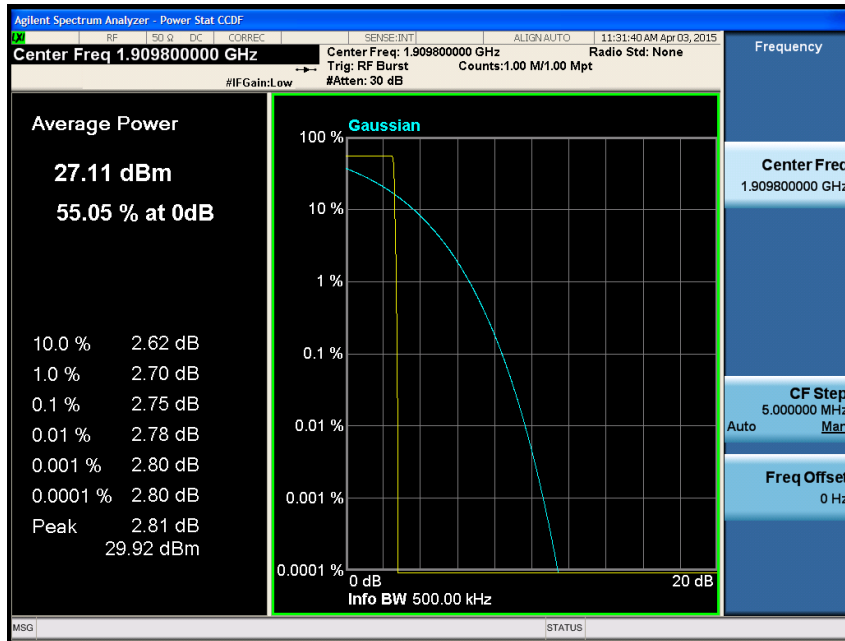

The results shown in this test report refer only to the sample(s) tested unless otherwise stated. This test report cannot be reproduced, except in full, without prior written permission of the Company.