



SAR EVALUATION REPORT

Applicant Name:
 LG Electronics MobileComm U.S.A., Inc.
 1000 Sylvan Avenue
 Englewood Cliffs, NJ 07632
 United States

Date of Testing:
 12/21/16 - 01/05/17
Test Site/Location:
 PCTEST Lab, Columbia, MD, USA
Document Serial No.:
 0Y1612232002-R2.ZNF

FCC ID: ZNFUS110

APPLICANT: LG ELECTRONICS MOBILECOMM U.S.A., INC.

DUT Type: Portable Handset
Application Type: Certification
FCC Rule Part(s): CFR §2.1093
Model: LG-US110
Additional Model(s): LGUS110, US110

Equipment Class	Band & Mode	Tx Frequency	SAR		
			1 gm Head (W/kg)	1 gm Body-Worn (W/kg)	1 gm Hotspot (W/kg)
PCE	Cell. CDMA/EVDO	824.70 - 848.31 MHz	0.62	0.92	0.89
PCE	PCS CDMA/EVDO	1851.25 - 1908.75 MHz	1.11	1.21	1.13
PCE	LTE Band 13	779.5 - 784.5 MHz	0.47	0.60	0.60
PCE	LTE Band 5 (Cell)	824.7 - 848.3 MHz	0.49	0.80	0.80
PCE	LTE Band 4 (AWS)	1710.7 - 1754.3 MHz	0.52	1.23	1.23
PCE	LTE Band 2 (PCS)	1850.7 - 1909.3 MHz	0.74	1.09	1.09
DTS	2.4 GHz WLAN	2412 - 2462 MHz	0.97	0.19	0.19
DSS/DTS	Bluetooth	2402 - 2480 MHz	N/A		
Simultaneous SAR per KDB 690783 D01v01r03:			1.59	1.44	1.41

Note: This revised Test Report (S/N: 0Y1612232002-R2.ZNF) supersedes and replaces the previously issued test report on the same subject device for the same type of testing as indicated. Please discard or destroy the previously issued test report(s) and dispose of it accordingly.

This wireless portable device has been shown to be capable of compliance for localized specific absorption rate (SAR) for uncontrolled environment/general population exposure limits specified in ANSI/IEEE C95.1-1992 and has been tested in accordance with the measurement procedures specified in Section 1.7 of this report; for North American frequency bands only.

I attest to the accuracy of data. All measurements reported herein were performed by me or were made under my supervision and are correct to the best of my knowledge and belief. I assume full responsibility for the completeness of these measurements and vouch for the qualifications of all persons taking them. Test results reported herein relate only to the item(s) tested.

 Randy Ortanez
 President



The SAR Tick is an initiative of the Mobile Manufacturers Forum (MMF). While a product may be considered eligible, use of the SAR Tick logo requires an agreement with the MMF. Further details can be obtained by emailing: sartick@mmfai.info.





FCC ID: ZNFUS110		SAR EVALUATION REPORT		Approved by: Quality Manager
Document S/N: 0Y1612232002-R2.ZNF	Test Dates: 12/21/16 - 01/05/17	DUT Type: Portable Handset	Page 1 of 50	

TABLE OF CONTENTS

1	DEVICE UNDER TEST	3
2	LTE INFORMATION	7
3	INTRODUCTION	8
4	DOSIMETRIC ASSESSMENT	9
5	DEFINITION OF REFERENCE POINTS	10
6	TEST CONFIGURATION POSITIONS	11
7	RF EXPOSURE LIMITS	14
8	FCC MEASUREMENT PROCEDURES.....	15
9	RF CONDUCTED POWERS	20
10	SYSTEM VERIFICATION.....	31
11	SAR DATA SUMMARY	33
12	FCC MULTI-TX AND ANTENNA SAR CONSIDERATIONS.....	41
13	SAR MEASUREMENT VARIABILITY	45
14	EQUIPMENT LIST.....	46
15	MEASUREMENT UNCERTAINTIES.....	47
16	CONCLUSION.....	48
17	REFERENCES	49
APPENDIX A:	SAR TEST PLOTS	
APPENDIX B:	SAR DIPOLE VERIFICATION PLOTS	
APPENDIX C:	PROBE AND DIPOLE CALIBRATION CERTIFICATES	
APPENDIX D:	SAR TISSUE SPECIFICATIONS	
APPENDIX E:	SAR SYSTEM VALIDATION	
APPENDIX F:	DUT ANTENNA DIAGRAM & SAR TEST SETUP PHOTOGRAPHS	

FCC ID: ZNFUS110	 SAR EVALUATION REPORT		Approved by: Quality Manager
Document S/N: OY1612232002-R2.ZNF	Test Dates: 12/21/16 - 01/05/17	DUT Type: Portable Handset	Page 2 of 50

1 DEVICE UNDER TEST

1.1 Device Overview

Band & Mode	Operating Modes	Tx Frequency
Cell. CDMA/EVDO	Voice/Data	824.70 - 848.31 MHz
PCS CDMA/EVDO	Voice/Data	1851.25 - 1908.75 MHz
LTE Band 13	Voice/Data	779.5 - 784.5 MHz
LTE Band 5 (Cell)	Voice/Data	824.7 - 848.3 MHz
LTE Band 4 (AWS)	Voice/Data	1710.7 - 1754.3 MHz
LTE Band 2 (PCS)	Voice/Data	1850.7 - 1909.3 MHz
2.4 GHz WLAN	Voice/Data	2412 - 2462 MHz
Bluetooth	Data	2402 - 2480 MHz

1.2 Power Reduction for SAR



There is no power reduction used for any band/mode implemented in this device for SAR purposes.

1.3 Nominal and Maximum Output Power Specifications

This device operates using the following maximum and nominal output power specifications. SAR values were scaled to the maximum allowed power to determine compliance per KDB Publication 447498 D01v06.

Mode / Band		Modulated Average (dBm)
Cell. CDMA/EVDO	Maximum	24.7
	Nominal	24.2
PCS CDMA/EVDO	Maximum	24.2
	Nominal	23.7

Mode / Band		Modulated Average (dBm)
LTE Band 13	Maximum	24.2
	Nominal	23.7
LTE Band 5 (Cell)	Maximum	24.5
	Nominal	24.0
LTE Band 4 (AWS)	Maximum	23.7
	Nominal	23.2
LTE Band 2 (PCS)	Maximum	23.7
	Nominal	23.2

FCC ID: ZNFUS110	 SAR EVALUATION REPORT 		Approved by: Quality Manager
Document S/N: 0Y1612232002-R2.ZNF	Test Dates: 12/21/16 - 01/05/17	DUT Type: Portable Handset	Page 3 of 50

Mode / Band		Modulated Average (dBm)		
		Ch. 1	Ch. 2-10	Ch. 11
IEEE 802.11b (2.4 GHz)	Maximum	16.5		
	Nominal	15.5		
IEEE 802.11g (2.4 GHz)	Maximum	13.5	14.5	11.5
	Nominal	12.5	13.5	10.5
IEEE 802.11n (2.4 GHz)	Maximum	12.5	13.5	10.5
	Nominal	11.5	12.5	9.5
Bluetooth	Maximum	10.0		
	Nominal	9.0		
Bluetooth LE	Maximum	1.0		

1.4 DUT Antenna Locations

The overall dimensions of this device are > 9 x 5 cm. The overall diagonal dimension of the device is ≤160 mm and the diagonal display is ≤150 mm. A diagram showing the location of the device antennas can be found in Appendix F.

**Table 1-1
Device Edges/Sides for SAR Testing**

Mode	Back	Front	Top	Bottom	Right	Left
Cell. EVDO	Yes	Yes	No	Yes	Yes	Yes
PCS EVDO	Yes	Yes	No	Yes	Yes	Yes
LTE Band 13	Yes	Yes	No	Yes	Yes	Yes
LTE Band 5 (Cell)	Yes	Yes	No	Yes	Yes	Yes
LTE Band 4 (AWS)	Yes	Yes	No	Yes	Yes	Yes
LTE Band 2 (PCS)	Yes	Yes	No	Yes	Yes	Yes
2.4 GHz WLAN	Yes	Yes	Yes	No	Yes	Yes

Note: Particular DUT edges were not required to be evaluated for wireless router SAR if the edges were greater than 2.5 cm from the transmitting antenna according to FCC KDB Publication 941225 D06v02r01 Section III. The distances between the transmit antennas and the edges of the device are included in the filing.

1.5 Simultaneous Transmission Capabilities

According to FCC KDB Publication 447498 D01v06, transmitters are considered to be transmitting simultaneously when there is overlapping transmission, with the exception of transmissions during network hand-offs with maximum hand-off duration less than 30 seconds. Possible transmission paths for the DUT are shown in Figure 1-1 and are color-coded to indicate communication modes which share the same path. Modes which share the same transmission path cannot transmit simultaneously with one another.

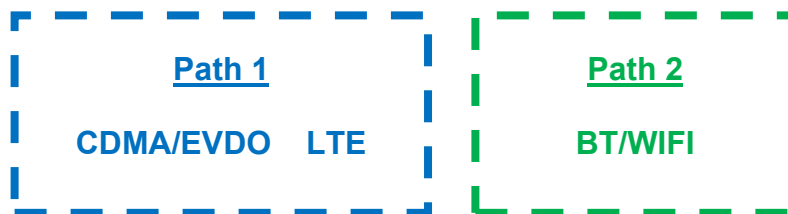

**Figure 1-1
Simultaneous Transmission Paths**

FCC ID: ZNFUS110	PCTEST ENGINEERING LABORATORY, INC.	SAR EVALUATION REPORT	LG	Approved by: Quality Manager
Document S/N: 0Y1612232002-R2.ZNF	Test Dates: 12/21/16 - 01/05/17	DUT Type: Portable Handset		Page 4 of 50

This device contains multiple transmitters that may operate simultaneously, and therefore requires a simultaneous transmission analysis according to FCC KDB Publication 447498 D01v06 4.3.2 procedures.

**Table 1-2
Simultaneous Transmission Scenarios**

No.	Capable Transmit Configuration	Head	Body-Worn Accessory	Wireless Router	Notes
1	1x CDMA voice + 2.4 GHz WI-FI	Yes	Yes	N/A	
2	1x CDMA voice + 2.4 GHz Bluetooth	N/A	Yes	N/A	
3	LTE + 2.4 GHz WI-FI	Yes	Yes	Yes	
4	LTE + 2.4 GHz Bluetooth	N/A	Yes	N/A	
5	CDMA/EVDO data + 2.4 GHz WI-FI	Yes*	Yes*	Yes	*-Pre-installed VOIP applications are considered.
6	CDMA/EVDO data + 2.4 GHz Bluetooth	N/A	Yes*	N/A	*-Pre-installed VOIP applications are considered.

- 2.4 GHz WLAN, and 2.4 GHz Bluetooth share the same antenna path and cannot transmit simultaneously.
- All licensed modes share the same antenna path and cannot transmit simultaneously.
- Per the manufacturer, WIFI Direct is expected to be used in conjunction with a held-to-ear or body-worn accessory voice call.
- This device supports VoLTE and VoWIFI

1.6 Miscellaneous SAR Test Considerations

(A) WIFI/BT

Per FCC KDB 447498 D01v06, the 1g SAR exclusion threshold for distances <50mm is defined by the following equation:

$$\frac{\text{Max Power of Channel (mW)}}{\text{Test Separation Dist (mm)}} * \sqrt{\text{Frequency(GHz)}} \leq 3.0$$



Based on the maximum conducted power of Bluetooth (rounded to the nearest mW) and the antenna to user separation distance, body-worn Bluetooth SAR was not required; $[(10/10) * \sqrt{2.480}] = 1.6 < 3.0$. Per KDB Publication 447498 D01v06, the maximum power of the channel was rounded to the nearest mW before calculation.

(B) Licensed Transmitter(s)

LTE SAR for the higher modulations and lower bandwidths were not tested since the maximum average output power of all required channels and configurations was not more than 0.5 dB higher than the highest bandwidth; and the reported LTE SAR for the highest bandwidth was less than 1.45 W/kg for all configurations according to FCC KDB 941225 D05v02r04.

1.7 Guidance Applied



- IEEE 1528-2013
- FCC KDB Publication 941225 D01v03r01, D05v02r04, D05Av01r02, D06v02r01 (2G/3G/4G and Hotspot)
- FCC KDB Publication 248227 D01v02r02 (SAR Considerations for 802.11 Devices)
- FCC KDB Publication 447498 D01v06 (General SAR Guidance)
- FCC KDB Publication 865664 D01v01r04, D02v01r02 (SAR Measurements up to 6 GHz)

FCC ID: ZNFUS110		SAR EVALUATION REPORT		Approved by: Quality Manager
Document S/N: 0Y1612232002-R2.ZNF	Test Dates: 12/21/16 - 01/05/17	DUT Type: Portable Handset		Page 5 of 50

1.8 Device Serial Numbers

Several samples with identical hardware were used to support SAR testing. The manufacturer has confirmed that the device(s) tested have the same physical, mechanical and thermal characteristics and are within operational tolerances expected for production units.



	Head Serial Number	Body-Worn Serial Number	Hotspot Serial Number
Cell. CDMA/EVDO	01321	01321	01321
PCS CDMA/EVDO	01321	01321	01321
LTE Band 13	01339	01339	01339
LTE Band 5 (Cell)	01339	01339	01339
LTE Band 4 (AWS)	01339	01339	01339
LTE Band 2 (PCS)	01339	01339	01339
2.4 GHz WLAN	01347	01347	01347

FCC ID: ZNFUS110	 PCTEST ENGINEERING LABORATORY, INC.	SAR EVALUATION REPORT	 LG	Approved by: Quality Manager
Document S/N: 0Y1612232002-R2.ZNF	Test Dates: 12/21/16 - 01/05/17	DUT Type: Portable Handset	Page 6 of 50	

2

LTE INFORMATION

LTE Information			
FCC ID	ZNFUS110		
Form Factor	Portable Handset		
Frequency Range of each LTE transmission band	LTE Band 13 (779.5 - 784.5 MHz)		
	LTE Band 5 (Cell) (824.7 - 848.3 MHz)		
	LTE Band 4 (AWS) (1710.7 - 1754.3 MHz)		
	LTE Band 2 (PCS) (1850.7 - 1909.3 MHz)		
Channel Bandwidths	LTE Band 13: 5 MHz, 10 MHz		
	LTE Band 5 (Cell): 1.4 MHz, 3 MHz, 5 MHz, 10 MHz		
	LTE Band 4 (AWS): 1.4 MHz, 3 MHz, 5 MHz, 10 MHz, 15 MHz, 20 MHz		
	LTE Band 2 (PCS): 1.4 MHz, 3 MHz, 5 MHz, 10 MHz, 15 MHz, 20 MHz		
Channel Numbers and Frequencies (MHz)	Low	Mid	High
LTE Band 13: 5 MHz	779.5 (23205)	782 (23230)	784.5 (23255)
LTE Band 13: 10 MHz	N/A	782 (23230)	N/A
LTE Band 5 (Cell): 1.4 MHz	824.7 (20407)	836.5 (20525)	848.3 (20643)
LTE Band 5 (Cell): 3 MHz	825.5 (20415)	836.5 (20525)	847.5 (20635)
LTE Band 5 (Cell): 5 MHz	826.5 (20425)	836.5 (20525)	846.5 (20625)
LTE Band 5 (Cell): 10 MHz	829 (20450)	836.5 (20525)	844 (20600)
LTE Band 4 (AWS): 1.4 MHz	1710.7 (19957)	1732.5 (20175)	1754.3 (20393)
LTE Band 4 (AWS): 3 MHz	1711.5 (19965)	1732.5 (20175)	1753.5 (20385)
LTE Band 4 (AWS): 5 MHz	1712.5 (19975)	1732.5 (20175)	1752.5 (20375)
LTE Band 4 (AWS): 10 MHz	1715 (20000)	1732.5 (20175)	1750 (20350)
LTE Band 4 (AWS): 15 MHz	1717.5 (20025)	1732.5 (20175)	1747.5 (20325)
LTE Band 4 (AWS): 20 MHz	1720 (20050)	1732.5 (20175)	1745 (20300)
LTE Band 2 (PCS): 1.4 MHz	1850.7 (18607)	1880 (18900)	1909.3 (19193)
LTE Band 2 (PCS): 3 MHz	1851.5 (18615)	1880 (18900)	1908.5 (19185)
LTE Band 2 (PCS): 5 MHz	1852.5 (18625)	1880 (18900)	1907.5 (19175)
LTE Band 2 (PCS): 10 MHz	1855 (18650)	1880 (18900)	1905 (19150)
LTE Band 2 (PCS): 15 MHz	1857.5 (18675)	1880 (18900)	1902.5 (19125)
LTE Band 2 (PCS): 20 MHz	1860 (18700)	1880 (18900)	1900 (19100)
UE Category	6		
Modulations Supported in UL	QPSK, 16QAM		
LTE MPR Permanently implemented per 3GPP TS 36.101 section 6.2.3~6.2.5? (manufacturer attestation to be provided)	YES		
A-MPR (Additional MPR) disabled for SAR Testing?	YES		
LTE Release 10 Additional Information	The following LTE Release 10 Features are not supported: CA, Relay, HetNet, Enhanced MIMO, eCIC, WIFI Offloading, MDH, eMBMS, Cross-Carrier Scheduling, Enhanced SC-FDMA.		

FCC ID: ZNFUS110		SAR EVALUATION REPORT		Approved by: Quality Manager
Document S/N: 0Y1612232002-R2.ZNF	Test Dates: 12/21/16 - 01/05/17	DUT Type: Portable Handset		Page 7 of 50

The FCC and Innovation, Science, and Economic Development Canada have adopted the guidelines for evaluating the environmental effects of radio frequency (RF) radiation in ET Docket 93-62 on Aug. 6, 1996 and Health Canada Safety Code 6 to protect the public and workers from the potential hazards of RF emissions due to FCC-regulated portable devices. [1]

The safety limits used for the environmental evaluation measurements are based on the criteria published by the American National Standards Institute (ANSI) for localized specific absorption rate (SAR) in IEEE/ANSI C95.1-1992 Standard for Safety Levels with Respect to Human Exposure to Radio Frequency Electromagnetic Fields, 3 kHz to 300 GHz [3] and Health Canada RF Exposure Guidelines Safety Code 6 [22]. The measurement procedure described in IEEE/ANSI C95.3-2002 Recommended Practice for the Measurement of Potentially Hazardous Electromagnetic Fields - RF and Microwave [4] is used for guidance in measuring the Specific Absorption Rate (SAR) due to the RF radiation exposure from the Equipment Under Test (EUT). These criteria for SAR evaluation are similar to those recommended by the International Committee for Non-Ionizing Radiation Protection (ICNIRP) in Biological Effects and Exposure Criteria for Radiofrequency Electromagnetic Fields,” Report No. Vol 74. SAR is a measure of the rate of energy absorption due to exposure to an RF transmitting source. SAR values have been related to threshold levels for potential biological hazards.

3.1 SAR Definition

Specific Absorption Rate is defined as the time derivative (rate) of the incremental energy (dU) absorbed by (dissipated in) an incremental mass (dm) contained in a volume element (dV) of a given density (ρ). It is also defined as the rate of RF energy absorption per unit mass at a point in an absorbing body (see Equation 3-1).

Equation 3-1
SAR Mathematical Equation

$$SAR = \frac{d}{dt} \left(\frac{dU}{dm} \right) = \frac{d}{dt} \left(\frac{dU}{\rho dv} \right)$$



SAR is expressed in units of Watts per Kilogram (W/kg).

$$SAR = \frac{\sigma \cdot E^2}{\rho}$$

where:

- σ = conductivity of the tissue-simulating material (S/m)
- ρ = mass density of the tissue-simulating material (kg/m³)
- E = Total RMS electric field strength (V/m)

NOTE: The primary factors that control rate of energy absorption were found to be the wavelength of the incident field in relation to the dimensions and geometry of the irradiated organism, the orientation of the organism in relation to the polarity of field vectors, the presence of reflecting surfaces, and whether conductive contact is made by the organism with a ground plane.[6]

FCC ID: ZNFUS110		SAR EVALUATION REPORT		Approved by: Quality Manager
Document S/N: 0Y1612232002-R2.ZNF	Test Dates: 12/21/16 - 01/05/17	DUT Type: Portable Handset		Page 8 of 50

4 DOSIMETRIC ASSESSMENT

4.1 Measurement Procedure

The evaluation was performed using the following procedure compliant to FCC KDB Publication 865664 D01v01r04 and IEEE 1528-2013:

1. The SAR distribution at the exposed side of the head or body was measured at a distance no greater than 5.0 mm from the inner surface of the shell. The area covered the entire dimension of the device-head and body interface and the horizontal grid resolution was determined per FCC KDB Publication 865664 D01v01r04 (See Table 4-1) and IEEE 1528-2013.
2. The point SAR measurement was taken at the maximum SAR region determined from Step 1 to enable the monitoring of SAR fluctuations/drifts during the 1g/10g cube evaluation. SAR at this fixed point was measured and used as a reference value.
3. Based on the area scan data, the peak of the region with maximum SAR was determined by spline interpolation. Around this point, a volume was assessed according to the measurement resolution and volume size requirements of FCC KDB Publication 865664 D01v01r04 (See Table 4-1) and IEEE 1528-2013. On the basis of this data set, the spatial peak SAR value was evaluated with the following procedure (see references or the DASy manual online for more details):
 - a. SAR values at the inner surface of the phantom are extrapolated from the measured values along the line away from the surface with spacing no greater than that in Table 4-1. The extrapolation was based on a least-squares algorithm. A polynomial of the fourth order was calculated through the points in the z-axis (normal to the phantom shell).
 - b. After the maximum interpolated values were calculated between the points in the cube, the SAR was averaged over the spatial volume (1g or 10g) using a 3D-Spline interpolation algorithm. The 3D-spline is composed of three one-dimensional splines with the "Not a knot" condition (in x, y, and z directions). The volume was then integrated with the trapezoidal algorithm. One thousand points (10 x 10 x 10) were obtained through interpolation, in order to calculate the averaged SAR.
 - c. All neighboring volumes were evaluated until no neighboring volume with a higher average value was found.
4. The SAR reference value, at the same location as step 2, was re-measured after the zoom scan was complete to calculate the SAR drift. If the drift deviated by more than 5%, the SAR test and drift measurements were repeated.

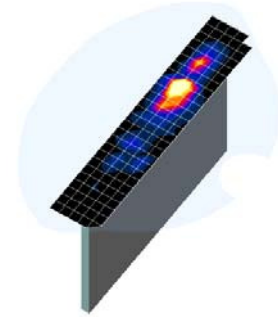

Figure 4-1
Sample SAR Area Scan

Table 4-1
Area and Zoom Scan Resolutions per FCC KDB Publication 865664 D01v01r04*

Frequency	Maximum Area Scan Resolution (mm) ($\Delta x_{area}, \Delta y_{area}$)	Maximum Zoom Scan Resolution (mm) ($\Delta x_{zoom}, \Delta y_{zoom}$)	Maximum Zoom Scan Spatial Resolution (mm)			Minimum Zoom Scan Volume (mm) (x,y,z)
			Uniform Grid	Graded Grid		
			$\Delta z_{zoom}(n)$	$\Delta z_{zoom}(1)^*$	$\Delta z_{zoom}(n>1)^*$	
≤ 2 GHz	≤ 15	≤ 8	≤ 5	≤ 4	≤ 1.5* $\Delta z_{zoom}(n-1)$	≥ 30
2-3 GHz	≤ 12	≤ 5	≤ 5	≤ 4	≤ 1.5* $\Delta z_{zoom}(n-1)$	≥ 30
3-4 GHz	≤ 12	≤ 5	≤ 4	≤ 3	≤ 1.5* $\Delta z_{zoom}(n-1)$	≥ 28
4-5 GHz	≤ 10	≤ 4	≤ 3	≤ 2.5	≤ 1.5* $\Delta z_{zoom}(n-1)$	≥ 25
5-6 GHz	≤ 10	≤ 4	≤ 2	≤ 2	≤ 1.5* $\Delta z_{zoom}(n-1)$	≥ 22

*Also compliant to IEEE 1528-2013 Table 6

FCC ID: ZNFUS110		SAR EVALUATION REPORT			Approved by: Quality Manager
Document S/N: 0Y1612232002-R2.ZNF	Test Dates: 12/21/16 - 01/05/17	DUT Type: Portable Handset			Page 9 of 50

5 DEFINITION OF REFERENCE POINTS

5.1 EAR REFERENCE POINT

Figure 5-2 shows the front, back and side views of the SAM Twin Phantom. The point “M” is the reference point for the center of the mouth, “LE” is the left ear reference point (ERP), and “RE” is the right ERP. The ERP is 15mm posterior to the entrance to the ear canal (EEC) along the B-M line (Back-Mouth), as shown in Figure 5-1. The plane passing through the two ear canals and M is defined as the Reference Plane. The line N-F (Neck-Front), also called the Reference Pivoting Line, is not perpendicular to the reference plane (see Figure 5-1). Line B-M is perpendicular to the N-F line. Both N-F and B-M lines are marked on the external phantom shell to facilitate handset positioning [5].

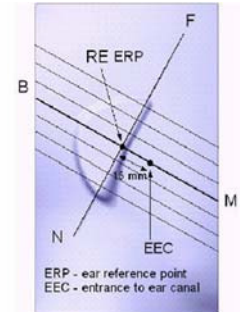

Figure 5-1
Close-Up Side view of ERP

5.2 HANDSET REFERENCE POINTS

Two imaginary lines on the handset were established: the vertical centerline and the horizontal line. The test device was placed in a normal operating position with the acoustic output located along the “vertical centerline” on the front of the device aligned to the “ear reference point” (See Figure 5-3). The acoustic output was then located at the same level as the center of the ear reference point. The test device was positioned so that the “vertical centerline” was bisecting the front surface of the handset at its top and bottom edges, positioning the “ear reference point” on the outer surface of the both the left and right head phantoms on the ear reference point.



Figure 5-2
Front, back and side view of SAM Twin Phantom

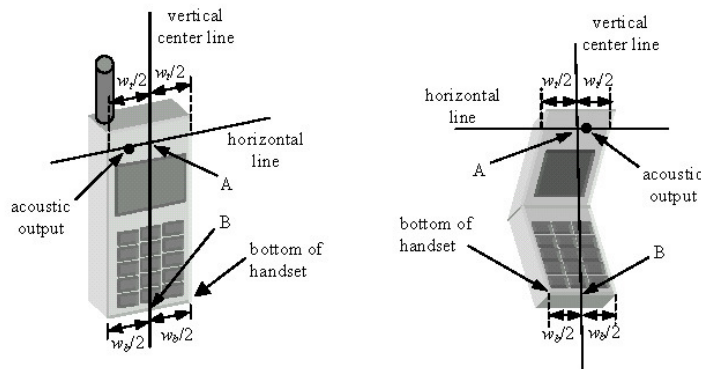



Figure 5-3
Handset Vertical Center & Horizontal Line Reference Points

FCC ID: ZNFUS110		SAR EVALUATION REPORT		Approved by: Quality Manager
Document S/N: 0Y1612232002-R2.ZNF	Test Dates: 12/21/16 - 01/05/17	DUT Type: Portable Handset		Page 10 of 50

6 TEST CONFIGURATION POSITIONS

6.1 Device Holder

The device holder is made out of low-loss POM material having the following dielectric parameters: relative permittivity $\epsilon = 3$ and loss tangent $\delta = 0.02$.

6.2 Positioning for Cheek

1. The test device was positioned with the device close to the surface of the phantom such that point A is on the (virtual) extension of the line passing through points RE and LE on the phantom (see Figure 6-1), such that the plane defined by the vertical center line and the horizontal line of the phone is approximately parallel to the sagittal plane of the phantom.





Figure 6-1 Front, Side and Top View of Cheek Position

2. The handset was translated towards the phantom along the line passing through RE & LE until the handset touches the pinna.
3. While maintaining the handset in this plane, the handset was rotated around the LE-RE line until the vertical centerline was in the reference plane.
4. The phone was then rotated around the vertical centerline until the phone (horizontal line) was symmetrical with respect to the line NF.
5. While maintaining the vertical centerline in the reference plane, keeping point A on the line passing through RE and LE, and maintaining the device contact with the ear, the device was rotated about the NF line until any point on the handset made contact with a phantom point below the ear (cheek) (See Figure 6-2).

6.3 Positioning for Ear / 15° Tilt

With the test device aligned in the “Cheek Position”:

1. While maintaining the orientation of the phone, the phone was retracted parallel to the reference plane far enough to enable a rotation of the phone by 15 degrees.
2. The phone was then rotated around the horizontal line by 15 degrees.
3. While maintaining the orientation of the phone, the phone was moved parallel to the reference plane until any part of the handset touched the head. (In this position, point A was located on the line RE-LE). The tilted position is obtained when the contact is on the pinna. If the contact was at any location other than the pinna, the angle of the phone would then be reduced. In this situation, the tilted position was obtained when any part of the phone was in contact of the ear as well as a second part of the phone was in contact with the head (see Figure 6-2).

FCC ID: ZNFUS110		SAR EVALUATION REPORT		Approved by: Quality Manager
Document S/N: 0Y1612232002-R2.ZNF	Test Dates: 12/21/16 - 01/05/17	DUT Type: Portable Handset		Page 11 of 50

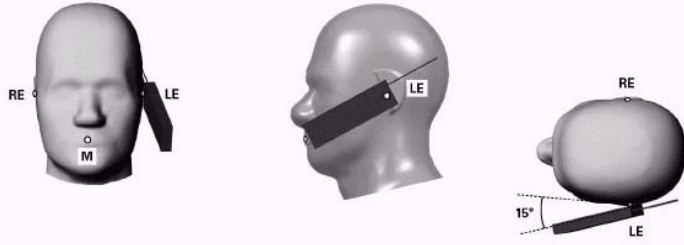

Figure 6-2 Front, Side and Top View of Ear/15° Tilt Position

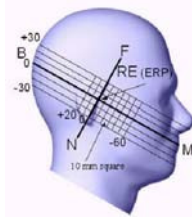

Figure 6-3 Side view w/ relevant markings

6.4 SAR Evaluations near the Mouth/Jaw Regions of the SAM Phantom

Antennas located near the bottom of a phone may require SAR measurements around the mouth and jaw regions of the SAM head phantom. This typically applies to clam-shell style phones that are generally longer in the unfolded normal use positions or to certain older style long rectangular phones. Per IEEE 1528-2013, a rotated SAM phantom is necessary to allow probe access to such regions. Both SAM heads of the TwinSAM-Chin20 are rotated 20 degrees around the NF line. Each head can be removed from the table for emptying and cleaning.

Under these circumstances, the following procedures apply, adopted from the FCC guidance on SAR handsets document FCC KDB Publication 648474 D04v01r03. The SAR required in these regions of SAM should be measured using a flat phantom. The phone should be positioned with a separation distance of 4 mm between the ear reference point (ERP) and the outer surface of the flat phantom shell. While maintaining this distance at the ERP location, the low (bottom) edge of the phone should be lowered from the phantom to establish the same separation distance between the peak SAR location identified by the truncated partial SAR distribution measured with the SAM phantom. The distance from the peak SAR location to the phone is determined by the straight line passing perpendicularly through the phantom surface. When it is not feasible to maintain 4 mm separation at the ERP while also establishing the required separation at the peak SAR location, the top edge of the phone will be allowed to touch the phantom with a separation < 4 mm at the ERP. The phone should not be tilted to the left or right while placed in this inclined position to the flat phantom.

6.5 Body-Worn Accessory Configurations

Body-worn operating configurations are tested with the belt-clips and holsters attached to the device and positioned against a flat phantom in a normal use configuration (see Figure 6-4). Per FCC KDB Publication 648474 D04v01r03, Body-worn accessory exposure is typically related to voice mode operations when handsets are carried in body-worn accessories. The body-worn accessory procedures in FCC KDB Publication 447498 D01v06 should be used to test for body-worn accessory SAR compliance, without a headset connected to it. This enables the test results for such configuration to be compatible with that required for hotspot mode when the body-worn accessory test separation distance is greater than or equal to that required for hotspot mode, when applicable. When the reported SAR for a body-worn accessory, measured without a headset connected to the handset, is > 1.2 W/kg, the highest reported SAR configuration for that wireless mode and frequency band should be repeated for that body-worn accessory with a headset attached to the handset.

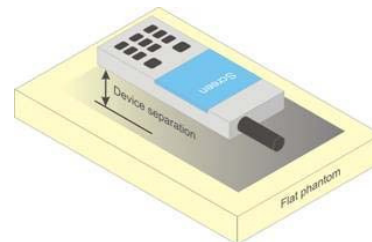



Figure 6-4 Sample Body-Worn Diagram

Accessories for Body-worn operation configurations are divided into two categories: those that do not contain metallic components and those that do contain metallic components. When multiple accessories that do not

FCC ID: ZNFUS110		SAR EVALUATION REPORT		Approved by: Quality Manager
Document S/N: 0Y1612232002-R2.ZNF	Test Dates: 12/21/16 - 01/05/17	DUT Type: Portable Handset		Page 12 of 50

contain metallic components are supplied with the device, the device is tested with only the accessory that dictates the closest spacing to the body. Then multiple accessories that contain metallic components are tested with the device with each accessory. If multiple accessories share an identical metallic component (i.e. the same metallic belt-clip used with different holsters with no other metallic components) only the accessory that dictates the closest spacing to the body is tested.

Body-worn accessories may not always be supplied or available as options for some devices intended to be authorized for body-worn use. In this case, a test configuration with a separation distance between the back of the device and the flat phantom is used. Test position spacing was documented.

Transmitters that are designed to operate in front of a person's face, as in push-to-talk configurations, are tested for SAR compliance with the front of the device positioned to face the flat phantom in head fluid. For devices that are carried next to the body such as a shoulder, waist or chest-worn transmitters, SAR compliance is tested with the accessories, including headsets and microphones, attached to the device and positioned against a flat phantom in a normal use configuration.

6.6 Extremity Exposure Configurations



Devices that are designed or intended for use on extremities or mainly operated in extremity only exposure conditions; i.e., hands, wrists, feet and ankles, may require extremity SAR evaluation. When the device also operates in close proximity to the user's body, SAR compliance for the body is also required. The 1-g body and 10-g extremity SAR Exclusion Thresholds found in KDB Publication 447498 D01v06 should be applied to determine SAR test requirements.

Per KDB Publication 447498 D01v06, Cell phones (handsets) are not normally designed to be used on extremities or operated in extremity only exposure conditions. The maximum output power levels of handsets generally do not require extremity SAR testing to show compliance. Therefore, extremity SAR was not evaluated for this device.

6.7 Wireless Router Configurations

Some battery-operated handsets have the capability to transmit and receive user data through simultaneous transmission of WIFI simultaneously with a separate licensed transmitter. The FCC has provided guidance in FCC KDB Publication 941225 D06v02r01 where SAR test considerations for handsets ($L \times W \geq 9 \text{ cm} \times 5 \text{ cm}$) are based on a composite test separation distance of 10 mm from the front, back and edges of the device containing transmitting antennas within 2.5 cm of their edges, determined from general mixed use conditions for this type of devices. Since the hotspot SAR results may overlap with the body-worn accessory SAR requirements, the more conservative configurations can be considered, thus excluding some body-worn accessory SAR tests.

When the user enables the personal wireless router functions for the handset, actual operations include simultaneous transmission of both the WIFI transmitter and another licensed transmitter. Both transmitters often do not transmit at the same transmitting frequency and thus cannot be evaluated for SAR under actual use conditions due to the limitations of the SAR assessment probes. Therefore, SAR must be evaluated for each frequency transmission and mode separately and spatially summed with the WIFI transmitter according to FCC KDB Publication 447498 D01v06 procedures. The "Portable Hotspot" feature on the handset was NOT activated during SAR assessments, to ensure the SAR measurements were evaluated for a single transmission frequency RF signal at a time.

FCC ID: ZNFUS110		SAR EVALUATION REPORT		Approved by: Quality Manager
Document S/N: 0Y1612232002-R2.ZNF	Test Dates: 12/21/16 - 01/05/17	DUT Type: Portable Handset		Page 13 of 50

7 RF EXPOSURE LIMITS

7.1 Uncontrolled Environment

UNCONTROLLED ENVIRONMENTS are defined as locations where there is the exposure of individuals who have no knowledge or control of their exposure. The general population/uncontrolled exposure limits are applicable to situations in which the general public may be exposed or in which persons who are exposed as a consequence of their employment may not be made fully aware of the potential for exposure or cannot exercise control over their exposure. Members of the general public would come under this category when exposure is not employment-related; for example, in the case of a wireless transmitter that exposes persons in its vicinity.



7.2 Controlled Environment

CONTROLLED ENVIRONMENTS are defined as locations where there is exposure that may be incurred by persons who are aware of the potential for exposure, (i.e. as a result of employment or occupation). In general, occupational/controlled exposure limits are applicable to situations in which persons are exposed as a consequence of their employment, who have been made fully aware of the potential for exposure and can exercise control over their exposure. This exposure category is also applicable when the exposure is of a transient nature due to incidental passage through a location where the exposure levels may be higher than the general population/uncontrolled limits, but the exposed person is fully aware of the potential for exposure and can exercise control over his or her exposure by leaving the area or by some other appropriate means.

Table 7-1
SAR Human Exposure Specified in ANSI/IEEE C95.1-1992 and Health Canada Safety Code 6

HUMAN EXPOSURE LIMITS		
	UNCONTROLLED ENVIRONMENT <i>General Population</i> (W/kg) or (mW/g)	CONTROLLED ENVIRONMENT <i>Occupational</i> (W/kg) or (mW/g)
Peak Spatial Average SAR Head	1.6	8.0
Whole Body SAR	0.08	0.4
Peak Spatial Average SAR Hands, Feet, Ankle, Wrists, etc.	4.0	20

1. The Spatial Peak value of the SAR averaged over any 1 gram of tissue (defined as a tissue volume in the shape of a cube) and over the appropriate averaging time.
2. The Spatial Average value of the SAR averaged over the whole body.
3. The Spatial Peak value of the SAR averaged over any 10 grams of tissue (defined as a tissue volume in the shape of a cube) and over the appropriate averaging time.

FCC ID: ZNFUS110		SAR EVALUATION REPORT		Approved by: Quality Manager
Document S/N: 0Y1612232002-R2.ZNF	Test Dates: 12/21/16 - 01/05/17	DUT Type: Portable Handset		Page 14 of 50

8 FCC MEASUREMENT PROCEDURES

Power measurements for licensed transmitters are performed using a base station simulator under digital average power.

8.1 Measured and Reported SAR

Per FCC KDB Publication 447498 D01v06, when SAR is not measured at the maximum power level allowed for production units, the results must be scaled to the maximum tune-up tolerance limit according to the power applied to the individual channels tested to determine compliance. For simultaneous transmission, the measured aggregate SAR must be scaled according to the sum of the differences between the maximum tune-up tolerance and actual power used to test each transmitter. When SAR is measured at or scaled to the maximum tune-up tolerance limit, the results are referred to as *reported* SAR. The highest *reported* SAR results are identified on the grant of equipment authorization according to procedures in KDB 690783 D01v01r03.

8.2 3G SAR Test Reduction Procedure

In FCC KDB Publication 941225 D01v03r01, certain transmission modes within a frequency band and wireless mode evaluated for SAR are defined as primary modes. The equivalent modes considered for SAR test reduction are denoted as secondary modes. When the maximum output power including tune-up tolerance specified for production units in a secondary mode is ≤ 0.25 dB higher than the primary mode or when the highest reported SAR of the primary mode, scaled by the ratio of specified maximum output power and tune-up tolerance of secondary to primary mode, is ≤ 1.2 W/kg, SAR measurements are not required for the secondary mode. These criteria are referred to as the 3G SAR test reduction procedure. When the 3G SAR test reduction procedure is not satisfied, SAR measurements are additionally required for the secondary mode.

8.3 Procedures Used to Establish RF Signal for SAR

The following procedures are according to FCC KDB Publication 941225 D01v03r01 “3G SAR Measurement Procedures.”



The device is placed into a simulated call using a base station simulator in a RF shielded chamber. Establishing connections in this manner ensure a consistent means for testing SAR and are recommended for evaluating SAR [4]. Devices under test are evaluated prior to testing, with a fully charged battery and were configured to operate at maximum output power. In order to verify that the device is tested throughout the SAR test at maximum output power, the SAR measurement system measures a “point SAR” at an arbitrary reference point at the start and end of the 1 gram SAR evaluation, to assess for any power drifts during the evaluation. If the power drift deviates by more than 5%, the SAR test and drift measurements are repeated.

8.4 SAR Measurement Conditions for CDMA2000

The following procedures were performed according to FCC KDB Publication 941225 D01v03r01 “3G SAR Measurement Procedures.”

8.4.1 Output Power Verification

See 3GPP2 C.S0011/TIA-98-E as recommended by FCC KDB Publication 941225 D01v03r01 “3G SAR Measurement Procedures.” Maximum output power is verified on the High, Middle and Low channels according to procedures in section 4.4.5.2 of 3GPP2 C.S0011/TIA-98-E. SO55 tests were measured with power control bits in the “All Up” condition.

FCC ID: ZNFUS110		SAR EVALUATION REPORT		Approved by: Quality Manager
Document S/N: 0Y1612232002-R2.ZNF	Test Dates: 12/21/16 - 01/05/17	DUT Type: Portable Handset		Page 15 of 50

1. If the mobile station (MS) supports Reverse TCH RC 1 and Forward TCH RC 1, set up a call using Fundamental Channel Test Mode 1 (RC=1/1) with 9600 bps data rate only.
2. Under RC1, C.S0011 Table 4.4.5.2-1, Table 8-1 parameters were applied.
3. If the MS supports the RC 3 Reverse FCH, RC3 Reverse SCH₀ and demodulation of RC 3,4, or 5, set up a call using Supplemental Channel Test Mode 3 (RC 3/3) with 9600 bps Fundamental Channel and 9600 bps SCH₀ data rate.
4. Under RC3, C.S0011 Table 4.4.5.2-2, Table 8-2 was applied.

Table 8-1
Parameters for Max. Power for RC1

Parameter	Units	Value
$\frac{I_{or}}{Pilot E_c}$	dBm/1.23 MHz	-104
$\frac{I_{or}}{Traffic E_c}$	dB	-7
$\frac{I_{or}}{Traffic E_c}$	dB	-7.4

Table 8-2
Parameters for Max. Power for RC3

Parameter	Units	Value
$\frac{I_{or}}{Pilot E_c}$	dBm/1.23 MHz	-86
$\frac{I_{or}}{Traffic E_c}$	dB	-7
$\frac{I_{or}}{Traffic E_c}$	dB	-7.4

5. FCHs were configured at full rate for maximum SAR with “All Up” power control bits.

8.4.2 Head SAR Measurements

SAR for next to the ear head exposure is measured in RC3 with the handset configured to transmit at fullrate in SO55. The 3G SAR test reduction procedure is applied to RC1 with RC3 as the primary mode; otherwise, SAR is required for the channel with maximum measured output in RC1 using the head exposure configuration that results in the highest reported SAR in RC3.

Head SAR is additionally evaluated using EVDO Rev. A to support compliance for VoIP operations. See Section 8.4.5 for EVDO Rev. A configuration parameters.

8.4.3 Body-worn SAR Measurements



SAR for body-worn exposure configurations is measured in RC3 with the DUT configured to transmit at full rate on FCH with all other code channels disabled using TDSO / SO32. The 3G SAR test reduction procedure is applied to the multiple code channel configuration (FCH+SCH_n), with FCH only as the primary mode. Otherwise, SAR is required for multiple code channel configuration (FCH + SCH_n), with FCH at full rate and SCH₀ enabled at 9600 bps, using the highest reported SAR configuration for FCH only. When multiple code channels are enabled, the transmitter output can shift by more than 0.5 dB and may lead to higher SAR drifts and SCH dropouts.

The 3G SAR test reduction procedure is applied to body-worn accessory SAR in RC1 with RC3 as the primary mode. Otherwise, SAR is required for RC1, with SO55 and full rate, using the highest reported SAR configuration for body-worn accessory exposure in RC3.

8.4.4 Body-worn SAR Measurements for EVDO Devices

For handsets with Ev-Do capabilities, the 3G SAR test reduction procedure is applied to Ev-Do Rev. 0 with 1x RTT RC3 as the primary mode to determine body-worn accessory test requirements. Otherwise, body-worn accessory SAR is required for Rev. 0, at 153.6 kbps, using the highest reported SAR configuration for body-worn accessory exposure in RC3.

The 3G SAR test reduction procedure is applied to Rev. A, with Rev. 0 as the primary mode to determine body-worn accessory SAR test requirements. When SAR is not required for Rev. 0, the 3G SAR test reduction is applied with 1x RTT RC3 as the primary mode.

FCC ID: ZNFUS110		SAR EVALUATION REPORT		Approved by: Quality Manager
Document S/N: 0Y1612232002-R2.ZNF	Test Dates: 12/21/16 - 01/05/17	DUT Type: Portable Handset		Page 16 of 50

When SAR is required for EVDO Rev. A, SAR is measured with a Reverse Data Channel payload size of 4096 bits and a Termination Target of 16 slots defined for Subtype 2 Physical Layer configurations, using the highest reported SAR configuration for body-worn accessory exposure in Rev. 0 or 1x RTT RC3, as appropriate.

8.4.5 Body SAR Measurements for EVDO Hotspot

Hotspot Body SAR is measured using Subtype 0/1 Physical Layer configurations for Rev. 0. The 3G SAR test reduction procedure is applied to Rev. A, Subtype 2 Physical layer configuration, with Rev. 0 as the primary mode; otherwise, SAR is measured for Rev. A using the highest reported SAR configuration for body-worn accessory exposure in Rev. 0. The AT is tested with a Reverse Data Channel rate of 153.6 kbps in Subtype 0/1 Physical Layer configurations; and a Reverse Data Channel payload size of 4096 bits and Termination Target of 16 slots in Subtype 2 Physical Layer configurations.

For Ev-Do data devices that also support 1x RTT voice and/or data operations, the 3G SAR test reduction procedure is applied to 1x RTT RC3 and RC1 with Ev-Do Rev. 0 and Rev. A as the respective primary modes. Otherwise, the 'Body-Worn Accessory SAR' procedures in the '3GPP2 CDMA 2000 1x Handsets' section are applied.

8.5 SAR Measurement Conditions for LTE

LTE modes are tested according to FCC KDB 941225 D05v02r04 publication. Establishing connections with base station simulators ensure a consistent means for testing SAR and are recommended for evaluating SAR [4]. The R&S CMW500 or Anritsu MT8820C simulators are used for LTE output power measurements and SAR testing. Closed loop power control was used so the UE transmits with maximum output power during SAR testing. SAR tests were performed with the same number of RB and RB offsets transmitting on all TTI frames (maximum TTI).

8.5.1 Spectrum Plots for RB Configurations

A properly configured base station simulator was used for SAR tests and power measurements. Therefore, spectrum plots for RB configurations were not required to be included in this report.

8.5.2 MPR

MPR is permanently implemented for this device by the manufacturer. The specific manufacturer target MPR is indicated alongside the SAR results. MPR is enabled for this device, according to 3GPP TS36.101 Section 6.2.3 – 6.2.5 under Table 6.2.3-1.



8.5.3 A-MPR

A-MPR (Additional MPR) has been disabled for all SAR tests by setting NS=01 on the base station simulator.

8.5.4 Required RB Size and RB Offsets for SAR Testing

According to FCC KDB 941225 D05v02r04:

- a. Per Section 5.2.1, SAR is required for QPSK 1 RB Allocation for the largest bandwidth
 - i. The required channel and offset combination with the highest maximum output power is required for SAR.
 - ii. When the reported SAR is ≤ 0.8 W/kg, testing of the remaining RB offset configurations and required test channels is not required. Otherwise, SAR is required for the remaining

FCC ID: ZNFUS110		SAR EVALUATION REPORT		Approved by: Quality Manager
Document S/N: 0Y1612232002-R2.ZNF	Test Dates: 12/21/16 - 01/05/17	DUT Type: Portable Handset		Page 17 of 50

- required test channels using the RB offset configuration with highest output power for that channel.
- iii. When the reported SAR for a required test channel is > 1.45 W/kg, SAR is required for all RB offset configurations for that channel.
- b. Per Section 5.2.2, SAR is required for 50% RB allocation using the largest bandwidth following the same procedures outlined in Section 5.2.1.
- c. Per Section 5.2.3, QPSK SAR is not required for the 100% allocation when the highest maximum output power for the 100% allocation is less than the highest maximum output power of the 1 RB and 50% RB allocations and the reported SAR for the 1 RB and 50% RB allocations is < 0.8 W/kg.
- d. Per Section 5.2.4 and 5.3, SAR tests for higher order modulations and lower bandwidths configurations are not required when the conducted power of the required test configurations determined by Sections 5.2.1 through 5.2.3 is less than or equal to ½ dB higher than the equivalent configuration using QPSK modulation and when the QPSK SAR for those configurations is <1.45 W/kg.

8.6 SAR Testing with 802.11 Transmitters

The normal network operating configurations of 802.11 transmitters are not suitable for SAR measurements. Unpredictable fluctuations in network traffic and antenna diversity conditions can introduce undesirable variations in SAR results. The SAR for these devices should be measured using chipset based test mode software to ensure the results are consistent and reliable. See KDB Publication 248227 D01v02r02 for more details.

8.6.1 General Device Setup

Chipset based test mode software is hardware dependent and generally varies among manufacturers. The device operating parameters established in test mode for SAR measurements must be identical to those programmed in production units, including output power levels, amplifier gain settings and other RF performance tuning parameters.

A periodic duty factor is required for current generation SAR systems to measure SAR. When 802.11 frame gaps are accounted for in the transmission, a maximum transmission duty factor of 92 - 96% is typically achievable in most test mode configurations. A minimum transmission duty factor of 85% is required to avoid certain hardware and device implementation issues related to wide range SAR scaling. The reported SAR is scaled to 100% transmission duty factor to determine compliance at the maximum tune-up tolerance limit.



8.6.2 Initial Test Position Procedure

For exposure conditions with multiple test positions, such as handset operating next to the ear, devices with hotspot mode or UMPC mini-tablet, procedures for initial test position can be applied. Using the transmission mode determined by the DSSS procedure or initial test configuration, area scans are measured for all positions in an exposure condition. The test position with the highest extrapolated (peak) SAR is used as the initial test position. When reported SAR for the initial test position is ≤ 0.4 W/kg, no additional testing for the remaining test positions is required. Otherwise, SAR is evaluated at the subsequent highest peak SAR positions until the reported SAR result is ≤ 0.8 W/kg or all test positions are measured.

8.6.3 2.4 GHz SAR Test Requirements

SAR is measured for 2.4 GHz 802.11b DSSS using either the fixed test position or, when applicable, the initial test position procedure. SAR test reduction is determined according to the following:

- 1) When the reported SAR of the highest measured maximum output power channel for the exposure configuration is ≤ 0.8 W/kg, no further SAR testing is required for 802.11b DSSS in that exposure configuration.

FCC ID: ZNFUS110		SAR EVALUATION REPORT		Approved by: Quality Manager
Document S/N: 0Y1612232002-R2.ZNF	Test Dates: 12/21/16 - 01/05/17	DUT Type: Portable Handset		Page 18 of 50

- 2) When the reported SAR is > 0.8 W/kg, SAR is required for that position using the next highest measured output power channel. When any reported SAR is > 1.2 W/kg, SAR is required for the third channel; i.e., all channels require testing.

2.4 GHz 802.11 g/n OFDM are additionally evaluated for SAR if the highest reported SAR for 802.11b, adjusted by the ratio of the OFDM to DSSS specified maximum output power, is > 1.2 W/kg. When SAR is required for OFDM modes in 2.4 GHz band, the Initial Test Configuration Procedures should be followed.

8.6.4 OFDM Transmission Mode and SAR Test Channel Selection

When the same maximum output power was specified for multiple OFDM transmission mode configurations in a frequency band or aggregated band, SAR is measured using the configuration with the largest channel bandwidth, lowest order modulation and lowest data rate. When the maximum output power of a channel is the same for equivalent OFDM configurations; for example, 802.11g and 802.11n with the same channel bandwidth, modulation and data rate etc., the lower order 802.11 mode i.e., 802.11g then 802.11n, is used for SAR measurement. When the maximum output power are the same for multiple test channels, either according to the default or additional power measurement requirements, SAR is measured using the channel closest to the middle of the frequency band or aggregated band. When there are multiple channels with the same maximum output power, SAR is measured using the higher number channel.



8.6.5 Initial Test Configuration Procedure

For OFDM, an initial test configuration is determined for each frequency band and aggregated band, according to the transmission mode with the highest maximum output power specified for SAR measurements. When the same maximum output power is specified for multiple OFDM transmission mode configurations in a frequency band or aggregated band, SAR is measured using the configuration(s) with the largest channel bandwidth, lowest order modulation, lowest data rate and lowest order IEEE 802.11 mode. The channel of the transmission mode with the highest average RF output conducted power will be the initial test configuration.

When the reported SAR is ≤ 0.8 W/kg, no additional measurements on other test channels are required. Otherwise, SAR is evaluated using the subsequent highest average RF output channel until the reported SAR result is ≤ 1.2 W/kg or all channels are measured. When there are multiple untested channels having the same subsequent highest average RF output power, the channel with higher frequency from the lowest 802.11 mode is considered for SAR measurements (See Section 8.6.4).

8.6.6 Subsequent Test Configuration Procedures

For OFDM configurations in each frequency band and aggregated band, SAR is evaluated for initial test configuration using the fixed test position or the initial test position procedure. When the highest reported SAR (for the initial test configuration), adjusted by the ratio of the specified maximum output power of the subsequent test configuration to initial test configuration, is ≤ 1.2 W/kg, no additional SAR tests for the subsequent test configurations are required.

FCC ID: ZNFUS110		SAR EVALUATION REPORT		Approved by: Quality Manager
Document S/N: 0Y1612232002-R2.ZNF	Test Dates: 12/21/16 - 01/05/17	DUT Type: Portable Handset		Page 19 of 50



9.1 CDMA Conducted Powers

Band	Channel	Frequency	SO55 [dBm]	SO55 [dBm]	TDSO SO32 [dBm]	TDSO SO32 [dBm]	1x EvDO Rev. 0 [dBm]	1x EvDO Rev. A [dBm]
	F-RC	MHz	RC1	RC3	FCH+SCH	FCH	(RTAP)	(RETAP)
Cellular	1013	824.7	24.60	24.62	24.65	24.49	24.60	24.50
	384	836.52	24.60	24.53	24.56	24.42	24.50	24.44
	777	848.31	24.57	24.50	24.52	24.41	24.50	24.47
PCS	25	1851.25	24.11	23.95	24.08	23.91	24.00	23.94
	600	1880	24.05	23.93	23.98	23.95	24.00	23.90
	1175	1908.75	24.11	23.95	23.93	23.95	24.00	23.97

Note: RC1 is only applicable for IS-95 compatibility.



Figure 9-1
Power Measurement Setup

FCC ID: ZNFUS110		SAR EVALUATION REPORT		Approved by: Quality Manager
Document S/N: 0Y1612232002-R2.ZNF	Test Dates: 12/21/16 - 01/05/17	DUT Type: Portable Handset		Page 20 of 50

9.2 LTE Conducted Powers

9.2.1 LTE Band 13



Table 9-1
LTE Band 13 Conducted Powers - 10 MHz Bandwidth

LTE Band 13 10 MHz Bandwidth					
Modulation	RB Size	RB Offset	Mid Channel	MPR Allowed per 3GPP [dB]	MPR [dB]
			23230 (782.0 MHz)		
			Conducted Power [dBm]		
QPSK	1	0	23.93	0	0
	1	25	23.82		0
	1	49	23.84		0
	25	0	23.02	0-1	1
	25	12	22.94		1
	25	25	23.07		1
	50	0	23.02		1
16QAM	1	0	22.85	0-1	1
	1	25	23.10		1
	1	49	23.00		1
	25	0	22.02	0-2	2
	25	12	21.80		2
	25	25	21.98		2
	50	0	21.97		2

Table 9-2
LTE Band 13 Conducted Powers - 5 MHz Bandwidth

LTE Band 13 5 MHz Bandwidth					
Modulation	RB Size	RB Offset	Mid Channel	MPR Allowed per 3GPP [dB]	MPR [dB]
			23230 (782.0 MHz)		
			Conducted Power [dBm]		
QPSK	1	0	23.85	0	0
	1	12	23.93		0
	1	24	23.86		0
	12	0	22.94	0-1	1
	12	6	23.00		1
	12	13	23.06		1
	25	0	22.90		1
16QAM	1	0	22.51	0-1	1
	1	12	22.79		1
	1	24	22.71		1
	12	0	21.86	0-2	2
	12	6	21.81		2
	12	13	21.96		2
	25	0	21.92		2

Note: LTE Band 13 at 5 MHz bandwidth does not support three non-overlapping channels. Per KDB Publication 941225 D05v02, when a device supports overlapping channel assignment in a channel bandwidth configuration, the middle channel of the group of overlapping channels should be selected for testing.

FCC ID: ZNFUS110		SAR EVALUATION REPORT		Approved by: Quality Manager
Document S/N: 0Y1612232002-R2.ZNF	Test Dates: 12/21/16 - 01/05/17	DUT Type: Portable Handset		Page 21 of 50

9.2.2

LTE Band 5 (Cell)



Table 9-3
LTE Band 5 (Cell) Conducted Powers - 10 MHz Bandwidth

LTE Band 5 (Cell) 10 MHz Bandwidth					
Modulation	RB Size	RB Offset	Mid Channel	MPR Allowed per 3GPP [dB]	MPR [dB]
			20525 (836.5 MHz)		
			Conducted Power [dBm]		
QPSK	1	0	24.34	0	0
	1	25	24.38		0
	1	49	24.15		0
	25	0	23.43	0-1	1
	25	12	23.17		1
	25	25	23.19		1
16QAM	50	0	23.35	0-1	1
	1	0	23.40		1
	1	25	23.45		1
	1	49	23.10	0-2	1
	25	0	22.30		2
	25	12	22.27		2
	25	25	22.08		2
50	0	22.35	2		

Note: LTE Band 5 (Cell) at 10 MHz bandwidth does not support three non-overlapping channels. Per KDB Publication 941225 D05v02, when a device supports overlapping channel assignment in a channel bandwidth configuration, the middle channel of the group of overlapping channels should be selected for testing.

Table 9-4
LTE Band 5 (Cell) Conducted Powers - 5 MHz Bandwidth

LTE Band 5 (Cell) 5 MHz Bandwidth								
Modulation	RB Size	RB Offset	Low Channel	Mid Channel	High Channel	MPR Allowed per 3GPP [dB]	MPR [dB]	
			20425 (826.5 MHz)	20525 (836.5 MHz)	20625 (846.5 MHz)			
			Conducted Power [dBm]					
QPSK	1	0	24.07	24.35	24.22	0	0	
	1	12	24.08	24.30	24.35		0	
	1	24	24.18	24.37	24.25		0	
	12	0	23.30	23.24	23.39	0-1	1	
	12	6	23.22	23.20	23.30		1	
	12	13	23.19	23.18	23.22		1	
16QAM	25	0	23.22	23.25	23.35	0-1	1	
	1	0	23.10	22.90	23.22		0-1	1
	1	12	23.07	22.95	23.37			1
	1	24	22.96	22.82	23.05	0-2		1
	12	0	22.10	22.38	22.37		2	
	12	6	22.11	22.27	22.32		2	
	12	13	22.28	22.35	22.30		2	
25	0	22.25	22.34	22.41	2			



FCC ID: ZNFUS110		SAR EVALUATION REPORT		Approved by: Quality Manager
Document S/N: 0Y1612232002-R2.ZNF	Test Dates: 12/21/16 - 01/05/17	DUT Type: Portable Handset		Page 22 of 50

**Table 9-5
LTE Band 5 (Cell) Conducted Powers - 3 MHz Bandwidth**

LTE Band 5 (Cell) 3 MHz Bandwidth							
Modulation	RB Size	RB Offset	Low Channel	Mid Channel	High Channel	MPR Allowed per 3GPP [dB]	MPR [dB]
			20415 (825.5 MHz)	20525 (836.5 MHz)	20635 (847.5 MHz)		
			Conducted Power [dBm]				
QPSK	1	0	24.25	24.47	24.40	0	0
	1	7	24.34	24.36	24.35		0
	1	14	24.30	24.32	24.36		0
	8	0	23.34	23.29	23.42	0-1	1
	8	4	23.34	23.13	23.29		1
	8	7	23.30	23.19	23.34		1
	15	0	23.28	23.27	23.41		1
16QAM	1	0	23.14	22.95	23.02	0-1	1
	1	7	23.40	22.76	22.95		1
	1	14	22.96	22.70	22.70		1
	8	0	22.42	22.23	22.44	0-2	2
	8	4	22.40	22.31	22.35		2
	8	7	22.27	22.22	22.21		2
	15	0	22.22	22.30	22.45		2

**Table 9-6
LTE Band 5 (Cell) Conducted Powers -1.4 MHz Bandwidth**

LTE Band 5 (Cell) 1.4 MHz Bandwidth							
Modulation	RB Size	RB Offset	Low Channel	Mid Channel	High Channel	MPR Allowed per 3GPP [dB]	MPR [dB]
			20407 (824.7 MHz)	20525 (836.5 MHz)	20643 (848.3 MHz)		
			Conducted Power [dBm]				
QPSK	1	0	24.22	24.42	24.07	0	0
	1	2	24.20	24.40	24.06		0
	1	5	24.19	24.38	24.05		0
	3	0	24.28	24.35	24.25		0
	3	2	24.29	24.33	24.24		0
	3	3	24.24	24.32	24.24	0	
	6	0	23.22	23.31	23.23	0-1	1
16QAM	1	0	23.00	23.07	23.09	0-1	1
	1	2	23.06	23.25	23.28		1
	1	5	22.90	22.90	22.97		1
	3	0	23.11	23.30	23.20		1
	3	2	23.30	23.31	23.35		1
	3	3	23.19	23.17	23.30	1	
	6	0	22.24	22.37	22.30	0-2	2

FCC ID: ZNFUS110		SAR EVALUATION REPORT		Approved by: Quality Manager
Document S/N: 0Y1612232002-R2.ZNF	Test Dates: 12/21/16 - 01/05/17	DUT Type: Portable Handset		Page 23 of 50

9.2.3

LTE Band 4 (AWS)



Table 9-7
LTE Band 4 (AWS) Conducted Powers - 20 MHz Bandwidth

LTE Band 4 (AWS) 20 MHz Bandwidth					
Modulation	RB Size	RB Offset	Mid Channel	MPR Allowed per 3GPP [dB]	MPR [dB]
			20175 (1732.5 MHz)		
			Conducted Power [dBm]		
QPSK	1	0	23.31	0	0
	1	50	23.40		0
	1	99	23.42		0
	50	0	22.57	0-1	1
	50	25	22.61		1
	50	50	22.68		1
16QAM	100	0	22.67	0-1	1
	1	0	22.20		1
	1	50	22.53		1
	1	99	22.50	0-2	1
	50	0	21.56		2
	50	25	21.33		2
16QAM	50	50	21.49	0-2	2
	100	0	21.46		2

Note: LTE Band 4 (AWS) at 20 MHz bandwidth does not support three non-overlapping channels. Per KDB Publication 941225 D05v02, when a device supports overlapping channel assignment in a channel bandwidth configuration, the middle channel of the group of overlapping channels should be selected for testing.

Table 9-8
LTE Band 4 (AWS) Conducted Powers - 15 MHz Bandwidth

LTE Band 4 (AWS) 15 MHz Bandwidth							
Modulation	RB Size	RB Offset	Low Channel	Mid Channel	High Channel	MPR Allowed per 3GPP [dB]	MPR [dB]
			20025 (1717.5 MHz)	20175 (1732.5 MHz)	20325 (1747.5 MHz)		
			Conducted Power [dBm]				
QPSK	1	0	23.52	23.62	23.45	0	0
	1	36	23.43	23.47	23.31		0
	1	74	23.49	23.54	23.39		0
	36	0	22.44	22.54	22.49	0-1	1
	36	18	22.46	22.45	22.39		1
	36	37	22.48	22.49	22.41		1
16QAM	75	0	22.50	22.52	22.30	0-1	1
	1	0	22.44	22.61	22.60		1
	1	36	22.60	22.61	22.63		1
	1	74	22.20	22.15	22.40	0-2	1
	36	0	21.25	21.42	21.48		2
	36	18	21.19	21.37	21.37		2
16QAM	36	37	21.20	21.46	21.31	0-2	2
	75	0	21.33	21.36	21.41		2

FCC ID: ZNFUS110		SAR EVALUATION REPORT			Approved by: Quality Manager
Document S/N: 0Y1612232002-R2.ZNF	Test Dates: 12/21/16 - 01/05/17	DUT Type: Portable Handset		Page 24 of 50	

**Table 9-9
LTE Band 4 (AWS) Conducted Powers - 10 MHz Bandwidth**

LTE Band 4 (AWS) 10 MHz Bandwidth							
Modulation	RB Size	RB Offset	Low Channel	Mid Channel	High Channel	MPR Allowed per 3GPP [dB]	MPR [dB]
			20000 (1715.0 MHz)	20175 (1732.5 MHz)	20350 (1750.0 MHz)		
			Conducted Power [dBm]				
QPSK	1	0	23.38	23.40	23.46	0	0
	1	25	23.48	23.40	23.35		0
	1	49	23.36	23.25	23.38		0
	25	0	22.51	22.56	22.56	0-1	1
	25	12	22.48	22.55	22.45		1
	25	25	22.47	22.57	22.51		1
	50	0	22.50	22.61	22.49		1
16QAM	1	0	22.30	22.42	22.63	0-1	1
	1	25	22.40	22.58	22.57		1
	1	49	22.20	22.41	22.22		1
	25	0	21.46	21.43	21.48	0-2	2
	25	12	21.40	21.50	21.37		2
	25	25	21.25	21.47	21.34		2
	50	0	21.23	21.43	21.48		2

**Table 9-10
LTE Band 4 (AWS) Conducted Powers - 5 MHz Bandwidth**

LTE Band 4 (AWS) 5 MHz Bandwidth							
Modulation	RB Size	RB Offset	Low Channel	Mid Channel	High Channel	MPR Allowed per 3GPP [dB]	MPR [dB]
			19975 (1712.5 MHz)	20175 (1732.5 MHz)	20375 (1752.5 MHz)		
			Conducted Power [dBm]				
QPSK	1	0	23.22	23.40	23.39	0	0
	1	12	23.40	23.56	23.61		0
	1	24	23.25	23.33	23.51		0
	12	0	22.37	22.54	22.57	0-1	1
	12	6	22.40	22.55	22.57		1
	12	13	22.41	22.57	22.60		1
	25	0	22.37	22.58	22.60		1
16QAM	1	0	22.15	22.20	22.00	0-1	1
	1	12	22.10	22.10	22.44		1
	1	24	22.00	22.40	22.10		1
	12	0	21.14	21.43	21.46	0-2	2
	12	6	21.20	21.44	21.39		2
	12	13	21.25	21.28	21.45		2
	25	0	21.49	21.24	21.47		2





FCC ID: ZNFUS110		SAR EVALUATION REPORT		Approved by: Quality Manager
Document S/N: 0Y1612232002-R2.ZNF	Test Dates: 12/21/16 - 01/05/17	DUT Type: Portable Handset		Page 25 of 50

Table 9-11
LTE Band 4 (AWS) Conducted Powers - 3 MHz Bandwidth

LTE Band 4 (AWS) 3 MHz Bandwidth							
Modulation	RB Size	RB Offset	Low Channel	Mid Channel	High Channel	MPR Allowed per 3GPP [dB]	MPR [dB]
			19965 (1711.5 MHz)	20175 (1732.5 MHz)	20385 (1753.5 MHz)		
			Conducted Power [dBm]				
QPSK	1	0	23.51	23.35	23.50	0	0
	1	7	23.43	23.26	23.44		0
	1	14	23.46	23.30	23.42		0
	8	0	22.44	22.57	22.58	0-1	1
	8	4	22.40	22.58	22.63		1
	8	7	22.41	22.55	22.56		1
	15	0	22.46	22.60	22.65		1
16QAM	1	0	22.52	22.43	22.57	0-1	1
	1	7	22.45	22.50	22.60		1
	1	14	22.07	21.92	22.32		1
	8	0	21.48	21.53	21.65	0-2	2
	8	4	21.47	21.64	21.51		2
	8	7	21.46	21.61	21.47		2
	15	0	21.46	21.38	21.48		2

Table 9-12
LTE Band 4 (AWS) Conducted Powers - 1.4 MHz Bandwidth

LTE Band 4 (AWS) 1.4 MHz Bandwidth							
Modulation	RB Size	RB Offset	Low Channel	Mid Channel	High Channel	MPR Allowed per 3GPP [dB]	MPR [dB]
			19957 (1710.7 MHz)	20175 (1732.5 MHz)	20393 (1754.3 MHz)		
			Conducted Power [dBm]				
QPSK	1	0	23.27	23.41	23.45	0	0
	1	2	23.28	23.30	23.41		0
	1	5	23.40	23.56	23.43		0
	3	0	23.37	23.53	23.55		0
	3	2	23.45	23.47	23.43		0
	3	3	23.40	23.46	23.40		0
	6	0	22.37	22.46	22.61	0-1	1
16QAM	1	0	22.13	22.30	22.55	0-1	1
	1	2	22.26	22.35	22.40		1
	1	5	22.00	22.10	22.15		1
	3	0	22.47	22.33	22.44		1
	3	2	22.52	22.40	22.42		1
	3	3	22.49	22.34	22.10		1
	6	0	21.48	21.35	21.18	0-2	2

FCC ID: ZNFUS110		SAR EVALUATION REPORT		Approved by: Quality Manager
Document S/N: 0Y1612232002-R2.ZNF	Test Dates: 12/21/16 - 01/05/17	DUT Type: Portable Handset		Page 26 of 50

9.2.4

LTE Band 2 (PCS)

Table 9-13
LTE Band 2 (PCS) Conducted Powers - 20 MHz Bandwidth

LTE Band 2 (PCS) 20 MHz Bandwidth							
Modulation	RB Size	RB Offset	Low Channel	Mid Channel	High Channel	MPR Allowed per 3GPP [dB]	MPR [dB]
			18700 (1860.0 MHz)	18900 (1880.0 MHz)	19100 (1900.0 MHz)		
			Conducted Power [dBm]				
QPSK	1	0	23.38	23.50	23.52	0	0
	1	50	23.63	23.60	23.65		0
	1	99	23.51	23.50	23.43		0
	50	0	22.43	22.46	22.56	0-1	1
	50	25	22.60	22.49	22.47		1
	50	50	22.61	22.40	22.45		1
16QAM	100	0	22.54	22.49	22.53	0-1	1
	1	0	22.43	22.60	22.30		1
	1	50	22.50	22.40	22.23		1
	1	99	22.47	22.43	22.15	0-2	1
	50	0	21.49	21.45	21.54		2
	50	25	21.67	21.42	21.26		2
	50	50	21.57	21.28	21.30	2	
	100	0	21.52	21.49	21.40	2	

Table 9-14
LTE Band 2 (PCS) Conducted Powers - 15 MHz Bandwidth

LTE Band 2 (PCS) 15 MHz Bandwidth							
Modulation	RB Size	RB Offset	Low Channel	Mid Channel	High Channel	MPR Allowed per 3GPP [dB]	MPR [dB]
			18675 (1857.5 MHz)	18900 (1880.0 MHz)	19125 (1902.5 MHz)		
			Conducted Power [dBm]				
QPSK	1	0	23.36	23.53	23.58	0	0
	1	36	23.40	23.52	23.52		0
	1	74	23.38	23.46	23.50		0
	36	0	22.43	22.46	22.46	0-1	1
	36	18	22.40	22.47	22.49		1
	36	37	22.39	22.57	22.51		1
16QAM	75	0	22.53	22.44	22.51	0-1	1
	1	0	22.34	22.58	22.67		1
	1	36	22.63	22.50	22.50		1
	1	74	22.55	22.45	22.46	0-2	1
	36	0	21.54	21.52	21.40		2
	36	18	21.49	21.53	21.33		2
	36	37	21.55	21.50	21.18	2	
	75	0	21.58	21.38	21.35	2	



FCC ID: ZNFUS110		SAR EVALUATION REPORT		Approved by: Quality Manager
Document S/N: 0Y1612232002-R2.ZNF	Test Dates: 12/21/16 - 01/05/17	DUT Type: Portable Handset		Page 27 of 50

Table 9-15
LTE Band 2 (PCS) Conducted Powers - 10 MHz Bandwidth

LTE Band 2 (PCS) 10 MHz Bandwidth							
Modulation	RB Size	RB Offset	Low Channel	Mid Channel	High Channel	MPR Allowed per 3GPP [dB]	MPR [dB]
			18650 (1855.0 MHz)	18900 (1880.0 MHz)	19150 (1905.0 MHz)		
			Conducted Power [dBm]				
QPSK	1	0	23.36	23.45	23.40	0	0
	1	25	23.30	23.65	23.45		0
	1	49	23.29	23.30	23.52		0
	25	0	22.42	22.48	22.50	0-1	1
	25	12	22.43	22.46	22.58		1
	25	25	22.42	22.46	22.55		1
	50	0	22.46	22.61	22.52		1
16QAM	1	0	22.40	22.46	22.35	0-1	1
	1	25	22.42	22.65	22.64		1
	1	49	22.42	22.35	22.40		1
	25	0	21.48	21.37	21.68	0-2	2
	25	12	21.50	21.46	21.69		2
	25	25	21.48	21.50	21.57		2
	50	0	21.49	21.53	21.47		2

Table 9-16
LTE Band 2 (PCS) Conducted Powers - 5 MHz Bandwidth

LTE Band 2 (PCS) 5 MHz Bandwidth							
Modulation	RB Size	RB Offset	Low Channel	Mid Channel	High Channel	MPR Allowed per 3GPP [dB]	MPR [dB]
			18625 (1852.5 MHz)	18900 (1880.0 MHz)	19175 (1907.5 MHz)		
			Conducted Power [dBm]				
QPSK	1	0	23.20	23.44	23.52	0	0
	1	12	23.29	23.58	23.52		0
	1	24	23.35	23.69	23.43		0
	12	0	22.29	22.48	22.62	0-1	1
	12	6	22.41	22.49	22.54		1
	12	13	22.45	22.54	22.49		1
	25	0	22.35	22.55	22.55		1
16QAM	1	0	21.98	22.42	22.24	0-1	1
	1	12	22.07	22.46	22.66		1
	1	24	22.21	22.35	22.59		1
	12	0	21.09	21.47	21.32	0-2	2
	12	6	21.24	21.49	21.15		2
	12	13	21.28	21.52	21.17		2
	25	0	21.34	21.48	21.31		2





FCC ID: ZNFUS110		SAR EVALUATION REPORT		Approved by: Quality Manager
Document S/N: 0Y1612232002-R2.ZNF	Test Dates: 12/21/16 - 01/05/17	DUT Type: Portable Handset		Page 28 of 50

Table 9-17
LTE Band 2 (PCS) Conducted Powers - 3 MHz Bandwidth

LTE Band 2 (PCS) 3 MHz Bandwidth							
Modulation	RB Size	RB Offset	Low Channel	Mid Channel	High Channel	MPR Allowed per 3GPP [dB]	MPR [dB]
			18615 (1851.5 MHz)	18900 (1880.0 MHz)	19185 (1908.5 MHz)		
			Conducted Power [dBm]				
QPSK	1	0	23.51	23.49	23.39	0	0
	1	7	23.55	23.48	23.55		0
	1	14	23.43	23.47	23.35		0
	8	0	22.43	22.43	22.58	0-1	1
	8	4	22.41	22.58	22.55		1
	8	7	22.35	22.53	22.53		1
	15	0	22.42	22.50	22.56		1
16QAM	1	0	22.30	22.40	22.50	0-1	1
	1	7	22.29	22.30	22.45		1
	1	14	22.42	22.40	22.50		1
	8	0	21.54	21.52	21.42	0-2	2
	8	4	21.65	21.58	21.41		2
	8	7	21.55	21.62	21.40		2
	15	0	21.55	21.31	21.45		2

Table 9-18
LTE Band 2 (PCS) Conducted Powers -1.4 MHz Bandwidth

LTE Band 2 (PCS) 1.4 MHz Bandwidth							
Modulation	RB Size	RB Offset	Low Channel	Mid Channel	High Channel	MPR Allowed per 3GPP [dB]	MPR [dB]
			18607 (1850.7 MHz)	18900 (1880.0 MHz)	19193 (1909.3 MHz)		
QPSK	1	0	23.45	23.57	23.43	0	0
	1	2	23.50	23.62	23.45		0
	1	5	23.52	23.46	23.45		0
	3	0	23.37	23.41	23.47		0
	3	2	23.36	23.55	23.51		0
	3	3	23.36	23.43	23.56		0
	6	0	22.35	22.42	22.46	0-1	1
16QAM	1	0	22.61	22.36	22.49	0-1	1
	1	2	22.57	22.47	22.51		1
	1	5	22.52	22.61	22.55		1
	3	0	22.42	22.53	22.46		1
	3	2	22.49	22.68	22.65		1
	3	3	22.46	22.55	22.47		1
	6	0	21.18	21.60	21.55	0-2	2

FCC ID: ZNFUS110		SAR EVALUATION REPORT		Approved by: Quality Manager
Document S/N: 0Y1612232002-R2.ZNF	Test Dates: 12/21/16 - 01/05/17	DUT Type: Portable Handset		Page 29 of 50

9.3 WLAN Conducted Powers

Table 9-19
IEEE 802.11b/g Average RF Power

Freq [MHz]	Channel	2.4GHz Conducted Power [dBm]	
		IEEE Transmission Mode	
		802.11b	802.11g
2412	1	15.78	13.18
2437	6	16.13	14.04
2462	11	15.63	10.81

Justification for test configurations for WLAN per KDB Publication 248227 D01v02r02:

- Power measurements were performed for the transmission mode configuration with the highest maximum output power specified for production units.
- For transmission modes with the same maximum output power specification, powers were measured for the largest channel bandwidth, lowest order modulation and lowest data rate.
- For transmission modes with identical maximum specified output power, channel bandwidth, modulation and data rates, power measurements were required for all identical configurations.
- For each transmission mode configuration, powers were measured for the highest and lowest channels; and at the mid-band channel(s) when there were at least 3 channels supported. For configurations with multiple mid-band channels, due to an even number of channels, both channels were measured.
- The bolded data rate and channel above were tested for SAR.

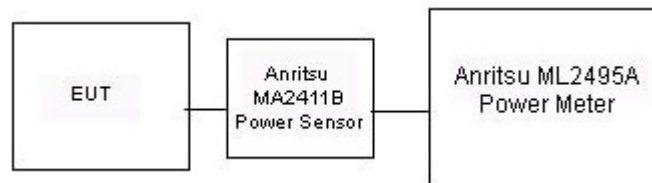



Figure 9-2
Power Measurement Setup for Bandwidths

FCC ID: ZNFUS110	 PCTEST ENGINEERING LABORATORY, INC.	SAR EVALUATION REPORT		Approved by: Quality Manager
Document S/N: 0Y1612232002-R2.ZNF	Test Dates: 12/21/16 - 01/05/17	DUT Type: Portable Handset	Page 30 of 50	



10 SYSTEM VERIFICATION

10.1 Tissue Verification

**Table 10-1
Measured Tissue Properties**

Calibrated for Tests Performed on:	Tissue Type	Tissue Temp During Calibration (°C)	Measured Frequency (MHz)	Measured Conductivity, σ (S/m)	Measured Dielectric Constant, ϵ	TARGET Conductivity, σ (S/m)	TARGET Dielectric Constant, ϵ	% dev σ	% dev ϵ
12/22/2016	750H	21.5	740	0.895	42.408	0.893	41.994	0.22%	0.99%
			755	0.908	42.202	0.894	41.916	1.57%	0.68%
			770	0.922	42.011	0.895	41.838	3.02%	0.41%
			785	0.937	41.827	0.896	41.760	4.58%	0.16%
12/22/2016	835H	21.5	820	0.889	41.557	0.899	41.578	-1.11%	-0.05%
			835	0.904	41.364	0.900	41.500	0.44%	-0.33%
			850	0.919	41.174	0.916	41.500	0.33%	-0.79%
12/24/2016	1750H	21.4	1710	1.342	40.865	1.348	40.142	-0.45%	1.80%
			1750	1.379	40.732	1.371	40.079	0.58%	1.63%
			1790	1.421	40.506	1.394	40.016	1.94%	1.22%
12/26/2016	1900H	21.4	1850	1.391	39.235	1.400	40.000	-0.64%	-1.91%
			1880	1.422	39.108	1.400	40.000	1.57%	-2.23%
			1910	1.455	39.004	1.400	40.000	3.93%	-2.49%
12/27/2016	2450H	23.0	2400	1.827	38.237	1.756	39.289	4.04%	-2.68%
			2450	1.885	38.127	1.800	39.200	4.72%	-2.74%
			2500	1.937	37.880	1.855	39.136	4.42%	-3.21%
12/22/2016	750B	21.3	740	0.954	54.333	0.963	55.570	-0.93%	-2.23%
			755	0.968	54.165	0.964	55.512	0.41%	-2.43%
			770	0.982	54.009	0.965	55.453	1.76%	-2.60%
			785	0.997	53.851	0.966	55.395	3.21%	-2.79%
12/21/2016	835B	22.2	820	0.983	54.266	0.969	55.258	1.44%	-1.80%
			835	0.998	54.136	0.970	55.200	2.89%	-1.93%
			850	1.013	53.997	0.988	55.154	2.53%	-2.10%
1/5/2017	835B	22.0	820	0.996	54.169	0.969	55.258	2.79%	-1.97%
			835	1.012	54.127	0.970	55.200	4.33%	-1.94%
			850	1.028	53.975	0.988	55.154	4.05%	-2.14%
12/26/2016	1750B	21.1	1710	1.467	51.561	1.463	53.537	0.27%	-3.69%
			1750	1.509	51.447	1.488	53.432	1.41%	-3.72%
			1790	1.548	51.209	1.514	53.326	2.25%	-3.97%
12/23/2016	1900B	22.5	1850	1.513	51.973	1.520	53.300	-0.46%	-2.49%
			1880	1.552	51.877	1.520	53.300	2.11%	-2.67%
			1910	1.582	51.810	1.520	53.300	4.08%	-2.80%
1/4/2017	1900B	23.5	1850	1.490	52.446	1.520	53.300	-1.97%	-1.60%
			1880	1.525	52.359	1.520	53.300	0.33%	-1.77%
			1910	1.556	52.278	1.520	53.300	2.37%	-1.92%
12/23/2016	2450B	23.1	2400	1.972	52.228	1.902	52.767	3.68%	-1.02%
			2450	2.032	51.985	1.950	52.700	4.21%	-1.36%
			2500	2.111	51.782	2.021	52.636	4.45%	-1.62%

The above measured tissue parameters were used in the DASY software. The DASY software was used to perform interpolation to determine the dielectric parameters at the SAR test device frequencies (per KDB Publication 865664 D01v01r04 and IEEE 1528-2013 6.6.1.2). The tissue parameters listed in the SAR test plots may slightly differ from the table above due to significant digit rounding in the software.

FCC ID: ZNFUS110		SAR EVALUATION REPORT			Approved by: Quality Manager
Document S/N: 0Y1612232002-R2.ZNF	Test Dates: 12/21/16 - 01/05/17	DUT Type: Portable Handset		Page 31 of 50	

10.2 Test System Verification

Prior to SAR assessment, the system is verified to $\pm 10\%$ of the SAR measurement on the reference dipole at the time of calibration by the calibration facility. Full system validation status and result summary can be found in Appendix E.

Table 10-2
System Verification Results

SAR System #	Tissue Frequency (MHz)	Tissue Type	Date:	Amb. Temp (°C)	Liquid Temp (°C)	Input Power (W)	Dipole SN	Probe SN	Measured SAR _{1g} (W/kg)	1 W Target SAR _{1g} (W/kg)	1 W Normalized SAR _{1g} (W/kg)	Deviation _{1g} (%)
G	750	HEAD	12/22/2016	23.7	21.9	0.200	1054	3287	1.540	8.220	7.700	-6.33%
E	835	HEAD	12/22/2016	22.7	21.5	0.200	4d047	7406	1.860	9.130	9.300	1.86%
E	1750	HEAD	12/24/2016	23.0	21.6	0.100	1148	7406	3.350	36.200	33.500	-7.46%
G	1900	HEAD	12/26/2016	23.3	22.0	0.100	5d149	3287	3.860	40.100	38.600	-3.74%
E	2450	HEAD	12/27/2016	21.0	22.5	0.100	981	7406	5.670	52.800	56.700	7.39%
J	750	BODY	12/22/2016	21.1	21.3	0.200	1054	3318	1.710	8.560	8.550	-0.12%
H	835	BODY	12/21/2016	23.1	22.2	0.200	4d047	3319	1.970	9.570	9.850	2.93%
H	835	BODY	01/05/2017	23.2	22.0	0.200	4d047	3319	1.970	9.570	9.850	2.93%
I	1750	BODY	12/26/2016	22.1	21.1	0.100	1148	3209	3.610	37.100	36.100	-2.70%
K	1900	BODY	12/23/2016	22.9	22.5	0.100	5d149	7409	4.140	39.900	41.400	3.76%
K	1900	BODY	01/04/2017	24.0	23.5	0.100	5d149	7409	4.220	39.900	42.200	5.76%
G	2450	BODY	12/23/2016	23.8	22.4	0.100	981	3287	5.280	50.800	52.800	3.94%

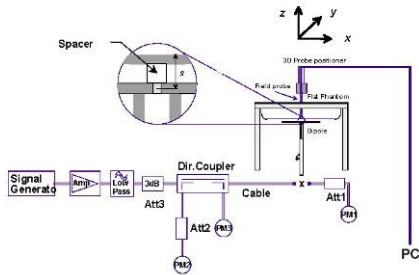

Figure 10-1
System Verification Setup Diagram



Figure 10-2
System Verification Setup Photo

FCC ID: ZNFUS110		SAR EVALUATION REPORT		Approved by: Quality Manager
Document S/N: 0Y1612232002-R2.ZNF	Test Dates: 12/21/16 - 01/05/17	DUT Type: Portable Handset		Page 32 of 50

11 SAR DATA SUMMARY



11.1 Standalone Head SAR Data

**Table 11-1
Cell. CDMA Head SAR**

MEASUREMENT RESULTS														
FREQUENCY		Mode/Band	Service	Maximum Allowed Power [dBm]	Conducted Power [dBm]	Power Drift [dB]	Side	Test Position	Device Serial Number	Duty Cycle	SAR (1g)	Scaling Factor	Reported SAR (1g)	Plot #
MHz	Ch.										(W/kg)		(W/kg)	
836.52	384	Cell. CDMA	RC3 / SO55	24.7	24.53	0.03	Right	Cheek	01321	1:1	0.572	1.040	0.595	
836.52	384	Cell. CDMA	RC3 / SO55	24.7	24.53	0.08	Right	Tilt	01321	1:1	0.327	1.040	0.340	
836.52	384	Cell. CDMA	RC3 / SO55	24.7	24.53	0.04	Left	Cheek	01321	1:1	0.537	1.040	0.558	
836.52	384	Cell. CDMA	RC3 / SO55	24.7	24.53	-0.08	Left	Tilt	01321	1:1	0.345	1.040	0.359	
836.52	384	Cell. CDMA	EVDO Rev. A	24.7	24.44	0.03	Right	Cheek	01321	1:1	0.583	1.062	0.619	A1
836.52	384	Cell. CDMA	EVDO Rev. A	24.7	24.44	-0.05	Right	Tilt	01321	1:1	0.351	1.062	0.373	
836.52	384	Cell. CDMA	EVDO Rev. A	24.7	24.44	0.04	Left	Cheek	01321	1:1	0.529	1.062	0.562	
836.52	384	Cell. CDMA	EVDO Rev. A	24.7	24.44	0.11	Left	Tilt	01321	1:1	0.305	1.062	0.324	
ANSI / IEEE C95.1 1992 - SAFETY LIMIT Spatial Peak Uncontrolled Exposure/General Population								Head 1.6 W/kg (mW/g) averaged over 1 gram						

**Table 11-2
PCS CDMA Head SAR**

MEASUREMENT RESULTS														
FREQUENCY		Mode/Band	Service	Maximum Allowed Power [dBm]	Conducted Power [dBm]	Power Drift [dB]	Side	Test Position	Device Serial Number	Duty Cycle	SAR (1g)	Scaling Factor	Reported SAR (1g)	Plot #
MHz	Ch.										(W/kg)		(W/kg)	
1880.00	600	PCS CDMA	RC3 / SO55	24.2	23.93	-0.03	Right	Cheek	01321	1:1	0.591	1.064	0.629	
1880.00	600	PCS CDMA	RC3 / SO55	24.2	23.93	0.10	Right	Tilt	01321	1:1	0.188	1.064	0.200	
1851.25	25	PCS CDMA	RC3 / SO55	24.2	23.95	0.18	Left	Cheek	01321	1:1	1.010	1.059	1.070	
1880.00	600	PCS CDMA	RC3 / SO55	24.2	23.93	-0.02	Left	Cheek	01321	1:1	0.940	1.064	1.000	
1908.75	1175	PCS CDMA	RC3 / SO55	24.2	23.95	0.07	Left	Cheek	01321	1:1	1.050	1.059	1.112	A2
1880.00	600	PCS CDMA	RC3 / SO55	24.2	23.93	0.03	Left	Tilt	01321	1:1	0.280	1.064	0.298	
1880.00	600	PCS CDMA	EVDO Rev. A	24.2	23.90	-0.08	Right	Cheek	01321	1:1	0.558	1.072	0.598	
1880.00	600	PCS CDMA	EVDO Rev. A	24.2	23.90	-0.13	Right	Tilt	01321	1:1	0.202	1.072	0.217	
1851.25	25	PCS CDMA	EVDO Rev. A	24.2	23.94	-0.11	Left	Cheek	01321	1:1	0.911	1.062	0.967	
1880.00	600	PCS CDMA	EVDO Rev. A	24.2	23.90	0.01	Left	Cheek	01321	1:1	0.907	1.072	0.972	
1908.75	1175	PCS CDMA	EVDO Rev. A	24.2	23.97	0.02	Left	Cheek	01321	1:1	0.871	1.054	0.918	
1880.00	600	PCS CDMA	EVDO Rev. A	24.2	23.90	-0.13	Left	Tilt	01321	1:1	0.253	1.072	0.271	
ANSI / IEEE C95.1 1992 - SAFETY LIMIT Spatial Peak Uncontrolled Exposure/General Population								Head 1.6 W/kg (mW/g) averaged over 1 gram						

FCC ID: ZNFUS110		SAR EVALUATION REPORT		Approved by: Quality Manager
Document S/N: 0Y1612232002-R2.ZNF	Test Dates: 12/21/16 - 01/05/17	DUT Type: Portable Handset		Page 33 of 50

**Table 11-3
LTE Band 13 Head SAR**



MEASUREMENT RESULTS																			
FREQUENCY		Mode	Bandwidth [MHz]	Maximum Allowed Power [dBm]	Conducted Power [dBm]	Power Drift [dB]	MPR [dB]	Side	Test Position	Modulation	RB Size	RB Offset	Device Serial Number	Duty Cycle	SAR (1g)	Scaling Factor	Reported SAR (1g)	Plot #	
MHz	Ch.														(W/kg)		(W/kg)		
782.00	23230	Mid	LTE Band 13	10	24.2	23.93	-0.04	0	Right	Cheek	QPSK	1	0	01339	1:1	0.438	1.064	0.466	A3
782.00	23230	Mid	LTE Band 13	10	23.2	23.07	-0.07	1	Right	Cheek	QPSK	25	25	01339	1:1	0.295	1.030	0.304	
782.00	23230	Mid	LTE Band 13	10	24.2	23.93	0.19	0	Right	Tilt	QPSK	1	0	01339	1:1	0.279	1.064	0.297	
782.00	23230	Mid	LTE Band 13	10	23.2	23.07	0.19	1	Right	Tilt	QPSK	25	25	01339	1:1	0.179	1.030	0.184	
782.00	23230	Mid	LTE Band 13	10	24.2	23.93	-0.15	0	Left	Cheek	QPSK	1	0	01339	1:1	0.348	1.064	0.370	
782.00	23230	Mid	LTE Band 13	10	23.2	23.07	0.07	1	Left	Cheek	QPSK	25	25	01339	1:1	0.285	1.030	0.294	
782.00	23230	Mid	LTE Band 13	10	24.2	23.93	-0.03	0	Left	Tilt	QPSK	1	0	01339	1:1	0.236	1.064	0.251	
782.00	23230	Mid	LTE Band 13	10	23.2	23.07	0.05	1	Left	Tilt	QPSK	25	25	01339	1:1	0.177	1.030	0.182	
ANSI / IEEE C95.1 1992 - SAFETY LIMIT Spatial Peak Uncontrolled Exposure/General Population										Head 1.6 W/kg (mW/g) averaged over 1 gram									

**Table 11-4
LTE Band 5 (Cell) Head SAR**

MEASUREMENT RESULTS																			
FREQUENCY		Mode	Bandwidth [MHz]	Maximum Allowed Power [dBm]	Conducted Power [dBm]	Power Drift [dB]	MPR [dB]	Side	Test Position	Modulation	RB Size	RB Offset	Device Serial Number	Duty Cycle	SAR (1g)	Scaling Factor	Reported SAR (1g)	Plot #	
MHz	Ch.														(W/kg)		(W/kg)		
836.50	20525	Mid	LTE Band 5 (Cell)	10	24.5	24.38	-0.17	0	Right	Cheek	QPSK	1	25	01339	1:1	0.481	1.028	0.494	A4
836.50	20525	Mid	LTE Band 5 (Cell)	10	23.5	23.43	0.08	1	Right	Cheek	QPSK	25	0	01339	1:1	0.392	1.017	0.399	
836.50	20525	Mid	LTE Band 5 (Cell)	10	24.5	24.38	-0.09	0	Right	Tilt	QPSK	1	25	01339	1:1	0.277	1.028	0.285	
836.50	20525	Mid	LTE Band 5 (Cell)	10	23.5	23.43	0.17	1	Right	Tilt	QPSK	25	0	01339	1:1	0.233	1.017	0.237	
836.50	20525	Mid	LTE Band 5 (Cell)	10	24.5	24.38	-0.07	0	Left	Cheek	QPSK	1	25	01339	1:1	0.388	1.028	0.399	
836.50	20525	Mid	LTE Band 5 (Cell)	10	23.5	23.43	0.05	1	Left	Cheek	QPSK	25	0	01339	1:1	0.339	1.017	0.345	
836.50	20525	Mid	LTE Band 5 (Cell)	10	24.5	24.38	0.10	0	Left	Tilt	QPSK	1	25	01339	1:1	0.231	1.028	0.237	
836.50	20525	Mid	LTE Band 5 (Cell)	10	23.5	23.43	0.14	1	Left	Tilt	QPSK	25	0	01339	1:1	0.199	1.017	0.202	
ANSI / IEEE C95.1 1992 - SAFETY LIMIT Spatial Peak Uncontrolled Exposure/General Population										Head 1.6 W/kg (mW/g) averaged over 1 gram									

**Table 11-5
LTE Band 4 (AWS) Head SAR**

MEASUREMENT RESULTS																			
FREQUENCY		Mode	Bandwidth [MHz]	Maximum Allowed Power [dBm]	Conducted Power [dBm]	Power Drift [dB]	MPR [dB]	Side	Test Position	Modulation	RB Size	RB Offset	Device Serial Number	Duty Cycle	SAR (1g)	Scaling Factor	Reported SAR (1g)	Plot #	
MHz	Ch.														(W/kg)		(W/kg)		
1732.50	20175	Mid	LTE Band 4 (AWS)	20	23.7	23.42	0.19	0	Right	Cheek	QPSK	1	99	01339	1:1	0.376	1.067	0.401	
1732.50	20175	Mid	LTE Band 4 (AWS)	20	22.7	22.68	0.03	1	Right	Cheek	QPSK	50	50	01339	1:1	0.293	1.005	0.294	
1732.50	20175	Mid	LTE Band 4 (AWS)	20	23.7	23.42	0.14	0	Right	Tilt	QPSK	1	99	01339	1:1	0.130	1.067	0.139	
1732.50	20175	Mid	LTE Band 4 (AWS)	20	22.7	22.68	-0.09	1	Right	Tilt	QPSK	50	50	01339	1:1	0.105	1.005	0.106	
1732.50	20175	Mid	LTE Band 4 (AWS)	20	23.7	23.42	0.01	0	Left	Cheek	QPSK	1	99	01339	1:1	0.483	1.067	0.515	A5
1732.50	20175	Mid	LTE Band 4 (AWS)	20	22.7	22.68	-0.03	1	Left	Cheek	QPSK	50	50	01339	1:1	0.388	1.005	0.390	
1732.50	20175	Mid	LTE Band 4 (AWS)	20	23.7	23.42	0.15	0	Left	Tilt	QPSK	1	99	01339	1:1	0.205	1.067	0.219	
1732.50	20175	Mid	LTE Band 4 (AWS)	20	22.7	22.68	-0.03	1	Left	Tilt	QPSK	50	50	01339	1:1	0.160	1.005	0.161	
ANSI / IEEE C95.1 1992 - SAFETY LIMIT Spatial Peak Uncontrolled Exposure/General Population										Head 1.6 W/kg (mW/g) averaged over 1 gram									

FCC ID: ZNFUS110		SAR EVALUATION REPORT		Approved by: Quality Manager
Document S/N: 0Y1612232002-R2.ZNF	Test Dates: 12/21/16 - 01/05/17	DUT Type: Portable Handset		Page 34 of 50

**Table 11-6
LTE Band 2 (PCS) Head SAR**

MEASUREMENT RESULTS																			
FREQUENCY		Mode	Bandwidth [MHz]	Maximum Allowed Power [dBm]	Conducted Power [dBm]	Power Drift [dB]	MPR [dB]	Side	Test Position	Modulation	RB Size	RB Offset	Device Serial Number	Duty Cycle	SAR (1g)	Scaling Factor	Reported SAR (1g)	Plot #	
MHz	Ch.														(W/kg)		(W/kg)		
1900.00	19100	High	LTE Band 2 (PCS)	20	23.7	23.65	0.11	0	Right	Cheek	QPSK	1	50	01339	1:1	0.491	1.012	0.497	
1860.00	18700	Low	LTE Band 2 (PCS)	20	22.7	22.61	0.06	1	Right	Cheek	QPSK	50	50	01339	1:1	0.369	1.021	0.377	
1900.00	19100	High	LTE Band 2 (PCS)	20	23.7	23.65	0.18	0	Right	Tilt	QPSK	1	50	01339	1:1	0.241	1.012	0.244	
1860.00	18700	Low	LTE Band 2 (PCS)	20	22.7	22.61	0.20	1	Right	Tilt	QPSK	50	50	01339	1:1	0.190	1.021	0.194	
1900.00	19100	High	LTE Band 2 (PCS)	20	23.7	23.65	0.04	0	Left	Cheek	QPSK	1	50	01339	1:1	0.733	1.012	0.742	A6
1860.00	18700	Low	LTE Band 2 (PCS)	20	22.7	22.61	0.01	1	Left	Cheek	QPSK	50	50	01339	1:1	0.565	1.021	0.577	
1900.00	19100	High	LTE Band 2 (PCS)	20	23.7	23.65	0.07	0	Left	Tilt	QPSK	1	50	01339	1:1	0.220	1.012	0.223	
1860.00	18700	Low	LTE Band 2 (PCS)	20	22.7	22.61	0.07	1	Left	Tilt	QPSK	50	50	01339	1:1	0.188	1.021	0.192	
ANSI / IEEE C95.1 1992 - SAFETY LIMIT Spatial Peak Uncontrolled Exposure/General Population										Head 1.6 W/kg (mW/g) averaged over 1 gram									



**Table 11-7
DTS Head SAR**

MEASUREMENT RESULTS																		
FREQUENCY		Mode	Service	Bandwidth [MHz]	Maximum Allowed Power [dBm]	Conducted Power [dBm]	Power Drift [dB]	Side	Test Position	Device Serial Number	Data Rate (Mbps)	Duty Cycle (%)	Peak SAR of Area Scan	SAR (1g)	Scaling Factor (Power)	Scaling Factor (Duty Cycle)	Reported SAR (1g)	Plot #
MHz	Ch.												(W/kg)	(W/kg)			(W/kg)	
2437	6	802.11b	DSSS	22	16.5	16.13	0.14	Right	Cheek	01347	1	99.2	0.949	0.541	1.089	1.008	0.594	
2437	6	802.11b	DSSS	22	16.5	16.13	0.21	Right	Tilt	01347	1	99.2	0.714	0.455	1.089	1.008	0.499	
2412	1	802.11b	DSSS	22	16.5	15.78	0.10	Left	Cheek	01347	1	99.2	1.164	0.758	1.180	1.008	0.902	
2437	6	802.11b	DSSS	22	16.5	16.13	-0.14	Left	Cheek	01347	1	99.2	1.281	0.847	1.089	1.008	0.930	
2437	6	802.11b	DSSS	22	16.5	16.13	0.18	Left	Tilt	01347	1	99.2	1.131	0.688	1.089	1.008	0.755	
2437	6	802.11b	DSSS	22	16.5	16.13	0.00	Left	Cheek	01347	1	99.2	1.396	0.884	1.089	1.008	0.970	A7
ANSI / IEEE C95.1 1992 - SAFETY LIMIT Spatial Peak Uncontrolled Exposure/General Population										Head 1.6 W/kg (mW/g) averaged over 1 gram								

11.2 Standalone Body-Worn SAR Data

**Table 11-8
CDMA Body-Worn SAR Data**

MEASUREMENT RESULTS																	
FREQUENCY		Mode	Service	Maximum Allowed Power [dBm]	Conducted Power [dBm]	Power Drift [dB]	Spacing	Accessory	Device Serial Number	Duty Cycle	Side	SAR (1g)	Scaling Factor	Reported SAR (1g)	Plot #		
MHz	Ch.											(W/kg)		(W/kg)			
824.70	1013	Cell. CDMA	TDSO / SO32	24.7	24.49	-0.03	10 mm	N/A	01321	1:1	back	0.781	1.050	0.820			
836.52	384	Cell. CDMA	TDSO / SO32	24.7	24.42	0.08	10 mm	N/A	01321	1:1	back	0.860	1.067	0.918			
848.31	777	Cell. CDMA	TDSO / SO32	24.7	24.41	0.03	10 mm	N/A	01321	1:1	back	0.841	1.069	0.899			
836.52	384	Cell. CDMA	TDSO / SO32	24.7	24.42	-0.04	10 mm	N/A	01321	1:1	back	0.863	1.067	0.921	A8		
1851.25	25	PCS CDMA	TDSO / SO32	24.2	23.91	-0.03	10 mm	N/A	01321	1:1	back	1.130	1.069	1.208	A10		
1851.25	25	PCS CDMA	TDSO / SO32	24.2	23.91	0.18	10 mm	Headphones	01321	1:1	back	0.615	1.069	0.657			
1880.00	600	PCS CDMA	TDSO / SO32	24.2	23.95	-0.03	10 mm	N/A	01321	1:1	back	0.954	1.059	1.010			
1908.75	1175	PCS CDMA	TDSO / SO32	24.2	23.95	-0.07	10 mm	N/A	01321	1:1	back	0.864	1.059	0.915			
1851.25	25	PCS CDMA	TDSO / SO32	24.2	23.91	0.11	10 mm	N/A	01321	1:1	back	1.120	1.069	1.197			
ANSI / IEEE C95.1 1992 - SAFETY LIMIT Spatial Peak Uncontrolled Exposure/General Population										Body 1.6 W/kg (mW/g) averaged over 1 gram							



FCC ID: ZNFUS110		SAR EVALUATION REPORT		Approved by: Quality Manager
Document S/N: 0Y1612232002-R2.ZNF	Test Dates: 12/21/16 - 01/05/17	DUT Type: Portable Handset	Page 35 of 50	

**Table 11-9
LTE Body-Worn SAR**

MEASUREMENT RESULTS																				
FREQUENCY		Mode	Bandwidth [MHz]	Accessory	Maximum Allowed Power [dBm]	Conducted Power [dBm]	Power Drift [dB]	MPR [dB]	Device Serial Number	Modulation	RB Size	RB Offset	Spacing	Side	Duty Cycle	SAR (1g)	Scaling Factor	Reported SAR	Plot #	
MHz	Ch.															(W/kg)		(W/kg)		
782.00	23230	Mid	LTE Band 13		N/A	24.2	23.93	0.15	0	01339	QPSK	1	0	10 mm	back	1:1	0.562	1.064	0.598	A12
782.00	23230	Mid	LTE Band 13		N/A	23.2	23.07	-0.02	1	01339	QPSK	25	25	10 mm	back	1:1	0.496	1.030	0.511	
836.50	20525	Mid	LTE Band 5 (Cell)		N/A	24.5	24.38	0.08	0	01339	QPSK	1	25	10 mm	back	1:1	0.777	1.028	0.799	A13
836.50	20525	Mid	LTE Band 5 (Cell)		N/A	23.5	23.43	-0.04	1	01339	QPSK	25	0	10 mm	back	1:1	0.574	1.017	0.584	
1732.50	20175	Mid	LTE Band 4 (AWS)		N/A	23.7	23.42	-0.16	0	01339	QPSK	1	99	10 mm	back	1:1	1.040	1.067	1.110	
1732.50	20175	Mid	LTE Band 4 (AWS)		Headphones	23.7	23.42	-0.05	0	01339	QPSK	1	99	10 mm	back	1:1	0.593	1.067	0.633	
1732.50	20175	Mid	LTE Band 4 (AWS)		N/A	22.7	22.68	-0.06	1	01339	QPSK	50	50	10 mm	back	1:1	0.840	1.005	0.844	
1732.50	20175	Mid	LTE Band 4 (AWS)		N/A	22.7	22.67	0.15	1	01339	QPSK	100	0	10 mm	back	1:1	0.841	1.007	0.847	
1732.50	20175	Mid	LTE Band 4 (AWS)		N/A	23.7	23.42	0.04	0	01339	QPSK	1	99	10 mm	back	1:1	1.150	1.067	1.227	A14
1860.00	18700	Low	LTE Band 2 (PCS)		N/A	23.7	23.63	0.09	0	01339	QPSK	1	50	10 mm	back	1:1	1.070	1.016	1.087	A15
1880.00	18900	Mid	LTE Band 2 (PCS)		N/A	23.7	23.60	0.01	0	01339	QPSK	1	50	10 mm	back	1:1	0.888	1.023	0.908	
1900.00	19100	High	LTE Band 2 (PCS)		N/A	23.7	23.65	-0.15	0	01339	QPSK	1	50	10 mm	back	1:1	0.799	1.012	0.809	
1860.00	18700	Low	LTE Band 2 (PCS)		N/A	22.7	22.61	0.05	1	01339	QPSK	50	50	10 mm	back	1:1	0.752	1.021	0.768	
1860.00	18700	Low	LTE Band 2 (PCS)		N/A	22.7	22.54	0.06	1	01339	QPSK	100	0	10 mm	back	1:1	0.788	1.038	0.818	
ANSI / IEEE C95.1 1992 - SAFETY LIMIT Spatial Peak										Body 1.6 W/kg (mW/g) averaged over 1 gram										
Uncontrolled Exposure/General Population																				

**Table 11-10
DTS Body-Worn SAR**

MEASUREMENT RESULTS																		
FREQUENCY		Mode	Service	Bandwidth [MHz]	Maximum Allowed Power [dBm]	Conducted Power [dBm]	Power Drift [dB]	Spacing	Device Serial Number	Data Rate (Mbps)	Side	Duty Cycle (%)	Peak SAR of Area Scan	SAR (1g)	Scaling Factor (Power)	Scaling Factor (Duty Cycle)	Reported SAR	Plot #
MHz	Ch.												(W/kg)	(W/kg)		(W/kg)		
2437	6	802.11b	DSSS	22	16.5	16.13	0.04	10 mm	01347	1	back	99.2	0.192	0.170	1.089	1.008	0.187	A16
ANSI / IEEE C95.1 1992 - SAFETY LIMIT Spatial Peak										Body 1.6 W/kg (mW/g) averaged over 1 gram								
Uncontrolled Exposure/General Population																		

FCC ID: ZNFUS110		SAR EVALUATION REPORT		Approved by: Quality Manager
Document S/N: 0Y1612232002-R2.ZNF	Test Dates: 12/21/16 - 01/05/17	DUT Type: Portable Handset		Page 36 of 50



11.3 Standalone Hotspot SAR Data

**Table 11-11
CDMA Hotspot SAR Data**

MEASUREMENT RESULTS														
FREQUENCY		Mode	Service	Maximum Allowed Power [dBm]	Conducted Power [dBm]	Power Drift [dB]	Spacing	Device Serial Number	Duty Cycle	Side	SAR (1g)	Scaling Factor	Reported SAR (1g)	Plot #
MHz	Ch.										(W/kg)		(W/kg)	
824.70	1013	Cell. CDMA	EVDO Rev. 0	24.7	24.60	0.04	10 mm	01321	1:1	back	0.781	1.023	0.799	
836.52	384	Cell. CDMA	EVDO Rev. 0	24.7	24.50	-0.09	10 mm	01321	1:1	back	0.845	1.047	0.885	A9
848.31	777	Cell. CDMA	EVDO Rev. 0	24.7	24.50	0.07	10 mm	01321	1:1	back	0.821	1.047	0.860	
836.52	384	Cell. CDMA	EVDO Rev. 0	24.7	24.50	-0.05	10 mm	01321	1:1	front	0.714	1.047	0.748	
836.52	384	Cell. CDMA	EVDO Rev. 0	24.7	24.50	-0.05	10 mm	01321	1:1	bottom	0.167	1.047	0.175	
836.52	384	Cell. CDMA	EVDO Rev. 0	24.7	24.50	0.01	10 mm	01321	1:1	right	0.516	1.047	0.540	
836.52	384	Cell. CDMA	EVDO Rev. 0	24.7	24.50	0.06	10 mm	01321	1:1	left	0.494	1.047	0.517	
1851.25	25	PCS CDMA	EVDO Rev. 0	24.2	24.00	-0.01	10 mm	01321	1:1	back	1.080	1.047	1.131	A11
1880.00	600	PCS CDMA	EVDO Rev. 0	24.2	24.00	0.04	10 mm	01321	1:1	back	1.030	1.047	1.078	
1908.75	1175	PCS CDMA	EVDO Rev. 0	24.2	24.00	-0.01	10 mm	01321	1:1	back	0.947	1.047	0.992	
1851.25	25	PCS CDMA	EVDO Rev. 0	24.2	24.00	0.16	10 mm	01321	1:1	front	1.020	1.047	1.068	
1880.00	600	PCS CDMA	EVDO Rev. 0	24.2	24.00	-0.01	10 mm	01321	1:1	front	0.898	1.047	0.940	
1908.75	1175	PCS CDMA	EVDO Rev. 0	24.2	24.00	-0.03	10 mm	01321	1:1	front	0.894	1.047	0.936	
1880.00	600	PCS CDMA	EVDO Rev. 0	24.2	24.00	0.02	10 mm	01321	1:1	bottom	0.355	1.047	0.372	
1880.00	600	PCS CDMA	EVDO Rev. 0	24.2	24.00	-0.08	10 mm	01321	1:1	right	0.181	1.047	0.190	
1851.25	25	PCS CDMA	EVDO Rev. 0	24.2	24.00	-0.20	10 mm	01321	1:1	left	0.712	1.047	0.745	
1880.00	600	PCS CDMA	EVDO Rev. 0	24.2	24.00	-0.12	10 mm	01321	1:1	left	0.768	1.047	0.804	
1908.75	1175	PCS CDMA	EVDO Rev. 0	24.2	24.00	-0.02	10 mm	01321	1:1	left	0.684	1.047	0.716	
ANSI / IEEE C95.1 1992 - SAFETY LIMIT Spatial Peak Uncontrolled Exposure/General Population							Body 1.6 W/kg (mW/g) averaged over 1 gram							

**Table 11-12
LTE Band 13 Hotspot SAR**

MEASUREMENT RESULTS																			
FREQUENCY		Mode	Bandwidth [MHz]	Maximum Allowed Power [dBm]	Conducted Power [dBm]	Power Drift [dB]	MPR [dB]	Device Serial Number	Modulation	RB Size	RB Offset	Spacing	Side	Duty Cycle	SAR (1g)	Scaling Factor	Reported SAR (1g)	Plot #	
MHz	Ch.														(W/kg)		(W/kg)		
782.00	23230	Mid	LTE Band 13	10	24.2	23.93	0.15	0	01339	QPSK	1	0	10 mm	back	1:1	0.562	1.064	0.598	A12
782.00	23230	Mid	LTE Band 13	10	23.2	23.07	-0.02	1	01339	QPSK	25	25	10 mm	back	1:1	0.496	1.030	0.511	
782.00	23230	Mid	LTE Band 13	10	24.2	23.93	-0.04	0	01339	QPSK	1	0	10 mm	front	1:1	0.411	1.064	0.437	
782.00	23230	Mid	LTE Band 13	10	23.2	23.07	0.02	1	01339	QPSK	25	25	10 mm	front	1:1	0.344	1.030	0.354	
782.00	23230	Mid	LTE Band 13	10	24.2	23.93	0.02	0	01339	QPSK	1	0	10 mm	bottom	1:1	0.102	1.064	0.109	
782.00	23230	Mid	LTE Band 13	10	23.2	23.07	0.02	1	01339	QPSK	25	25	10 mm	bottom	1:1	0.091	1.030	0.094	
782.00	23230	Mid	LTE Band 13	10	24.2	23.93	-0.16	0	01339	QPSK	1	0	10 mm	right	1:1	0.339	1.064	0.361	
782.00	23230	Mid	LTE Band 13	10	23.2	23.07	-0.04	1	01339	QPSK	25	25	10 mm	right	1:1	0.309	1.030	0.318	
782.00	23230	Mid	LTE Band 13	10	24.2	23.93	0.03	0	01339	QPSK	1	0	10 mm	left	1:1	0.245	1.064	0.261	
782.00	23230	Mid	LTE Band 13	10	23.2	23.07	-0.18	1	01339	QPSK	25	25	10 mm	left	1:1	0.228	1.030	0.235	
ANSI / IEEE C95.1 1992 - SAFETY LIMIT Spatial Peak Uncontrolled Exposure/General Population							Body 1.6 W/kg (mW/g) averaged over 1 gram												



FCC ID: ZNFUS110		SAR EVALUATION REPORT		Approved by: Quality Manager
Document S/N: 0Y1612232002-R2.ZNF	Test Dates: 12/21/16 - 01/05/17	DUT Type: Portable Handset	Page 37 of 50	

**Table 11-13
LTE Band 5 (Cell) Hotspot SAR**

MEASUREMENT RESULTS																			
FREQUENCY		Mode	Bandwidth [MHz]	Maximum Allowed Power [dBm]	Conducted Power [dBm]	Power Drift [dB]	MPR [dB]	Device Serial Number	Modulation	RB Size	RB Offset	Spacing	Side	Duty Cycle	SAR (1g)	Scaling Factor	Reported SAR (1g)	Plot #	
MHz	Ch.														(W/kg)		(W/kg)		
836.50	20525	Mid	LTE Band 5 (Cell)	10	24.5	24.38	0.08	0	01339	QPSK	1	25	10 mm	back	1:1	0.777	1.028	0.799	A13
836.50	20525	Mid	LTE Band 5 (Cell)	10	23.5	23.43	-0.04	1	01339	QPSK	25	0	10 mm	back	1:1	0.574	1.017	0.584	
836.50	20525	Mid	LTE Band 5 (Cell)	10	24.5	24.38	0.14	0	01339	QPSK	1	25	10 mm	front	1:1	0.706	1.028	0.726	
836.50	20525	Mid	LTE Band 5 (Cell)	10	23.5	23.43	-0.03	1	01339	QPSK	25	0	10 mm	front	1:1	0.491	1.017	0.499	
836.50	20525	Mid	LTE Band 5 (Cell)	10	24.5	24.38	0.16	0	01339	QPSK	1	25	10 mm	bottom	1:1	0.170	1.028	0.175	
836.50	20525	Mid	LTE Band 5 (Cell)	10	23.5	23.43	-0.03	1	01339	QPSK	25	0	10 mm	bottom	1:1	0.112	1.017	0.114	
836.50	20525	Mid	LTE Band 5 (Cell)	10	24.5	24.38	-0.07	0	01339	QPSK	1	25	10 mm	right	1:1	0.488	1.028	0.502	
836.50	20525	Mid	LTE Band 5 (Cell)	10	23.5	23.43	-0.03	1	01339	QPSK	25	0	10 mm	right	1:1	0.330	1.017	0.336	
836.50	20525	Mid	LTE Band 5 (Cell)	10	24.5	24.38	-0.03	0	01339	QPSK	1	25	10 mm	left	1:1	0.497	1.028	0.511	
836.50	20525	Mid	LTE Band 5 (Cell)	10	23.5	23.43	-0.04	1	01339	QPSK	25	0	10 mm	left	1:1	0.322	1.017	0.327	
ANSI / IEEE C95.1 1992 - SAFETY LIMIT Spatial Peak Uncontrolled Exposure/General Population								Body 1.6 W/kg (mW/g) averaged over 1 gram											

**Table 11-14
LTE Band 4 (AWS) Hotspot SAR**

MEASUREMENT RESULTS																			
FREQUENCY		Mode	Bandwidth [MHz]	Maximum Allowed Power [dBm]	Conducted Power [dBm]	Power Drift [dB]	MPR [dB]	Device Serial Number	Modulation	RB Size	RB Offset	Spacing	Side	Duty Cycle	SAR (1g)	Scaling Factor	Reported SAR (1g)	Plot #	
MHz	Ch.														(W/kg)		(W/kg)		
1732.50	20175	Mid	LTE Band 4 (AWS)	20	23.7	23.42	-0.16	0	01339	QPSK	1	99	10 mm	back	1:1	1.040	1.067	1.110	
1732.50	20175	Mid	LTE Band 4 (AWS)	20	22.7	22.68	-0.06	1	01339	QPSK	50	50	10 mm	back	1:1	0.840	1.005	0.844	
1732.50	20175	Mid	LTE Band 4 (AWS)	20	22.7	22.67	0.15	1	01339	QPSK	100	0	10 mm	back	1:1	0.841	1.007	0.847	
1732.50	20175	Mid	LTE Band 4 (AWS)	20	23.7	23.42	-0.03	0	01339	QPSK	1	99	10 mm	front	1:1	0.817	1.067	0.872	
1732.50	20175	Mid	LTE Band 4 (AWS)	20	22.7	22.68	-0.03	1	01339	QPSK	50	50	10 mm	front	1:1	0.625	1.005	0.628	
1732.50	20175	Mid	LTE Band 4 (AWS)	20	22.7	22.67	0.08	1	01339	QPSK	100	0	10 mm	front	1:1	0.632	1.007	0.636	
1732.50	20175	Mid	LTE Band 4 (AWS)	20	23.7	23.42	-0.02	0	01339	QPSK	1	99	10 mm	bottom	1:1	0.377	1.067	0.402	
1732.50	20175	Mid	LTE Band 4 (AWS)	20	22.7	22.68	-0.07	1	01339	QPSK	50	50	10 mm	bottom	1:1	0.289	1.005	0.290	
1732.50	20175	Mid	LTE Band 4 (AWS)	20	23.7	23.42	0.02	0	01339	QPSK	1	99	10 mm	right	1:1	0.115	1.067	0.123	
1732.50	20175	Mid	LTE Band 4 (AWS)	20	22.7	22.68	-0.08	1	01339	QPSK	50	50	10 mm	right	1:1	0.084	1.005	0.084	
1732.50	20175	Mid	LTE Band 4 (AWS)	20	23.7	23.42	0.00	0	01339	QPSK	1	99	10 mm	left	1:1	0.400	1.067	0.427	
1732.50	20175	Mid	LTE Band 4 (AWS)	20	22.7	22.68	0.02	1	01339	QPSK	50	50	10 mm	left	1:1	0.321	1.005	0.323	
1732.50	20175	Mid	LTE Band 4 (AWS)	20	23.7	23.42	0.04	0	01339	QPSK	1	99	10 mm	back	1:1	1.150	1.067	1.227	A14
ANSI / IEEE C95.1 1992 - SAFETY LIMIT Spatial Peak Uncontrolled Exposure/General Population								Body 1.6 W/kg (mW/g) averaged over 1 gram											

FCC ID: ZNFUS110		SAR EVALUATION REPORT		Approved by: Quality Manager
Document S/N: 0Y1612232002-R2.ZNF	Test Dates: 12/21/16 - 01/05/17	DUT Type: Portable Handset	Page 38 of 50	

**Table 11-15
LTE Band 2 (PCS) Hotspot SAR**

MEASUREMENT RESULTS																			
FREQUENCY		Mode	Bandwidth [MHz]	Maximum Allowed Power [dBm]	Conducted Power [dBm]	Power Drift [dB]	MPR [dB]	Device Serial Number	Modulation	RB Size	RB Offset	Spacing	Side	Duty Cycle	SAR (1g) (W/kg)	Scaling Factor	Reported SAR (1g) (W/kg)	Plot #	
MHz	Ch.																		
1860.00	18700	Low	LTE Band 2 (PCS)	20	23.7	23.63	0.09	0	01339	QPSK	1	50	10 mm	back	1:1	1.070	1.016	1.087	A15
1880.00	18900	Mid	LTE Band 2 (PCS)	20	23.7	23.60	0.01	0	01339	QPSK	1	50	10 mm	back	1:1	0.888	1.023	0.908	
1900.00	19100	High	LTE Band 2 (PCS)	20	23.7	23.65	-0.15	0	01339	QPSK	1	50	10 mm	back	1:1	0.799	1.012	0.809	
1860.00	18700	Low	LTE Band 2 (PCS)	20	22.7	22.61	0.05	1	01339	QPSK	50	50	10 mm	back	1:1	0.752	1.021	0.768	
1860.00	18700	Low	LTE Band 2 (PCS)	20	22.7	22.54	0.06	1	01339	QPSK	100	0	10 mm	back	1:1	0.788	1.038	0.818	
1860.00	18700	Low	LTE Band 2 (PCS)	20	23.7	23.63	-0.03	0	01339	QPSK	1	50	10 mm	front	1:1	0.929	1.016	0.944	
1880.00	18900	Mid	LTE Band 2 (PCS)	20	23.7	23.60	0.06	0	01339	QPSK	1	50	10 mm	front	1:1	0.787	1.023	0.805	
1900.00	19100	High	LTE Band 2 (PCS)	20	23.7	23.65	0.11	0	01339	QPSK	1	50	10 mm	front	1:1	0.788	1.012	0.797	
1860.00	18700	Low	LTE Band 2 (PCS)	20	22.7	22.61	-0.01	1	01339	QPSK	50	50	10 mm	front	1:1	0.668	1.021	0.682	
1860.00	18700	Low	LTE Band 2 (PCS)	20	22.7	22.54	0.17	1	01339	QPSK	100	0	10 mm	front	1:1	0.629	1.038	0.653	
1900.00	19100	High	LTE Band 2 (PCS)	20	23.7	23.65	0.18	0	01339	QPSK	1	50	10 mm	bottom	1:1	0.301	1.012	0.305	
1860.00	18700	Low	LTE Band 2 (PCS)	20	22.7	22.61	-0.04	1	01339	QPSK	50	50	10 mm	bottom	1:1	0.259	1.021	0.264	
1900.00	19100	High	LTE Band 2 (PCS)	20	23.7	23.65	0.05	0	01339	QPSK	1	50	10 mm	right	1:1	0.137	1.012	0.139	
1860.00	18700	Low	LTE Band 2 (PCS)	20	22.7	22.61	-0.06	1	01339	QPSK	50	50	10 mm	right	1:1	0.115	1.021	0.117	
1900.00	19100	High	LTE Band 2 (PCS)	20	23.7	23.65	0.06	0	01339	QPSK	1	50	10 mm	left	1:1	0.603	1.012	0.610	
1860.00	18700	Low	LTE Band 2 (PCS)	20	22.7	22.61	0.16	1	01339	QPSK	50	50	10 mm	left	1:1	0.481	1.021	0.491	
ANSI / IEEE C95.1 1992 - SAFETY LIMIT Spatial Peak Uncontrolled Exposure/General Population										Body 1.6 W/kg (mW/g) averaged over 1 gram									



**Table 11-16
WLAN Hotspot SAR**

MEASUREMENT RESULTS																		
FREQUENCY		Mode	Service	Bandwidth [MHz]	Maximum Allowed Power [dBm]	Conducted Power [dBm]	Power Drift [dB]	Spacing	Device Serial Number	Data Rate (Mbps)	Side	Duty Cycle (%)	Peak SAR of Area Scan (W/kg)	SAR (1g) (W/kg)	Scaling Factor (Power)	Scaling Factor (Duty Cycle)	Reported SAR (1g) (W/kg)	Plot #
MHz	Ch.																	
2437	6	802.11b	DSSS	22	16.5	16.13	0.04	10 mm	01347	1	back	99.2	0.192	0.170	1.089	1.008	0.187	A16
2437	6	802.11b	DSSS	22	16.5	16.13	-0.06	10 mm	01347	1	front	99.2	0.174	-	1.089	1.008	-	
2437	6	802.11b	DSSS	22	16.5	16.13	-0.06	10 mm	01347	1	top	99.2	0.107	-	1.089	1.008	-	
2437	6	802.11b	DSSS	22	16.5	16.13	0.11	10 mm	01347	1	right	99.2	0.095	-	1.089	1.008	-	
2437	6	802.11b	DSSS	22	16.5	16.13	0.14	10 mm	01347	1	left	99.2	0.015	-	1.089	1.008	-	
ANSI / IEEE C95.1 1992 - SAFETY LIMIT Spatial Peak Uncontrolled Exposure/General Population										Body 1.6 W/kg (mW/g) averaged over 1 gram								

11.4 SAR Test Notes

General Notes:

1. The test data reported are the worst-case SAR values according to test procedures specified in IEEE 1528-2013, and FCC KDB Publication 447498 D01v06.
2. Batteries are fully charged at the beginning of the SAR measurements.
3. Liquid tissue depth was at least 15.0 cm for all frequencies.
4. The manufacturer has confirmed that the device(s) tested have the same physical, mechanical and thermal characteristics and are within operational tolerances expected for production units.
5. SAR results were scaled to the maximum allowed power to demonstrate compliance per FCC KDB Publication 447498 D01v06.
6. Device was tested using a fixed spacing for body-worn accessory testing. A separation distance of 10 mm was considered because the manufacturer has determined that there will be body-worn accessories available in the marketplace for users to support this separation distance.

FCC ID: ZNFUS110		SAR EVALUATION REPORT		Approved by: Quality Manager
Document S/N: OY1612232002-R2.ZNF	Test Dates: 12/21/16 - 01/05/17	DUT Type: Portable Handset		Page 39 of 50

7. Per FCC KDB Publication 648474 D04v01r03, body-worn SAR was evaluated without a headset connected to the device. Since the standalone reported body-worn SAR was > 1.2 W/kg, additional body-worn SAR evaluations using a headset cable were required.
8. Per FCC KDB 865664 D01v01r04, variability SAR tests were performed when the measured SAR results for a frequency band were greater than or equal to 0.8 W/kg. Repeated SAR measurements are highlighted in the tables above for clarity. Please see Section 13 for variability analysis.
9. During SAR Testing for the Wireless Router conditions per FCC KDB Publication 941225 D06v02r01, the actual Portable Hotspot operation (with actual simultaneous transmission of a transmitter with WIFI) was not activated (See Section 6.7 for more details).

CDMA Notes:



1. Head SAR for CDMA2000 mode was tested under RC3/SO55 per FCC KDB Publication 941225 D01v03r01.
2. Body-Worn SAR was tested with 1x RTT with TDSO / SO32 FCH Only. EVDO Rev0 and RevA and TDSO / SO32 FCH+SCH SAR tests were not required per the 3G SAR Test Reduction Procedure in FCC KDB Publication 941225 D01v03r01.
3. CDMA Wireless Router SAR is measured using Subtype 0/1 Physical Layer configurations for Rev. 0 according to KDB 941225 D01v03r01 procedures for data devices. Wireless Router SAR tests for Subtype 2 of Rev.A and 1x RTT configurations were not required per the 3G SAR Test Reduction Policy in KDB Publication 941225 D01v03r01.
4. Head SAR was additionally evaluated using EVDO Rev. A to determine compliance for VoIP operations.
5. Per FCC KDB Publication 447498 D01v06, if the reported (scaled) SAR measured at the middle channel or highest output power channel for each test configuration is ≤ 0.8 W/kg then testing at the other channels is not required for such test configuration(s). When the maximum output power variation across the required test channels is > ½ dB, instead of the middle channel, the highest output power channel was used.

LTE Notes:

1. LTE Considerations: LTE test configurations are determined according to SAR Evaluation Considerations for LTE Devices in FCC KDB Publication 941225 D05v02r04. The general test procedures used for testing can be found in Section 8.5.4.
2. MPR is permanently implemented for this device by the manufacturer. The specific manufacturer target MPR is indicated alongside the SAR results. MPR is enabled for this device, according to 3GPP TS36.101 Section 6.2.3 – 6.2.5 under Table 6.2.3-1.
3. A-MPR was disabled for all SAR tests by setting NS=01 on the base station simulator. SAR tests were performed with the same number of RB and RB offsets transmitting on all TTI frames (maximum TTI).

WLAN Notes:

1. For held-to-ear and hotspot operations, the initial test position procedures were applied. The test position with the highest extrapolated peak SAR will be used as the initial test position. When reported SAR for the initial test position is ≤ 0.4 W/kg, no additional testing for the remaining test positions was required. Otherwise, SAR is evaluated at the subsequent highest peak SAR positions until the reported SAR result is ≤ 0.8 W/kg or all test positions are measured.
2. Justification for test configurations for WLAN per KDB Publication 248227 D01v02r02 for 2.4 GHz WIFI operations, the highest measured maximum output power channel for DSSS was selected for SAR measurement. SAR for OFDM modes (2.4 GHz 802.11g/n) was not required due to the maximum allowed powers and the highest reported DSSS SAR. See Section 8.6.3 for more information. When the maximum reported 1g averaged SAR is ≤0.8 W/kg, SAR testing on additional channels was not required. Otherwise, SAR for the next highest output power channel was required until the reported SAR result was ≤ 1.20 W/kg or all test channels were measured.
3. The device was configured to transmit continuously at the required data rate, channel bandwidth and signal modulation, using the highest transmission duty factor supported by the test mode tools. The reported SAR was scaled to the 100% transmission duty factor to determine compliance. Procedures used to measure the duty factor are identical to that in the associated EMC test reports.

FCC ID: ZNFUS110		SAR EVALUATION REPORT		Approved by: Quality Manager
Document S/N: 0Y1612232002-R2.ZNF	Test Dates: 12/21/16 - 01/05/17	DUT Type: Portable Handset	Page 40 of 50	

12 FCC MULTI-TX AND ANTENNA SAR CONSIDERATIONS

12.1 Introduction

The following procedures adopted from FCC KDB Publication 447498 D01v06 are applicable to devices with built-in unlicensed transmitters such as 802.11 and Bluetooth devices which may simultaneously transmit with the licensed transmitter.

12.2 Simultaneous Transmission Procedures

This device contains transmitters that may operate simultaneously. Therefore simultaneous transmission analysis is required. Per FCC KDB Publication 447498 D01v06 4.3.2 and IEEE 1528-2013 Section 6.3.4.1.2, simultaneous transmission SAR test exclusion may be applied when the sum of the 1-g SAR for all the simultaneous transmitting antennas in a specific a physical test configuration is ≤ 1.6 W/kg. The different test positions in an exposure condition may be considered collectively to determine SAR test exclusion according to the sum of 1-g.

When standalone SAR is not required to be measured, per FCC KDB 447498 D01v06 4.3.2 b), the following equation must be used to estimate the standalone 1g SAR for simultaneous transmission assessment involving that transmitter.



$$\text{Estimated SAR} = \frac{\sqrt{f(\text{GHz})}}{7.5} * \frac{(\text{Max Power of channel, mW})}{\text{Min. Separation Distance, mm}}$$

**Table 12-1
Estimated SAR**

Mode	Frequency	Maximum Allowed Power	Separation Distance (Body)	Estimated SAR (Body)
	[MHz]	[dBm]	[mm]	[W/kg]
Bluetooth	2480	10.00	10	0.210

Note: Held-to ear configurations are not applicable to Bluetooth operations and therefore were not considered for simultaneous transmission. Per KDB Publication 447498 D01v06, the maximum power of the channel was rounded to the nearest mW before calculation.

For SAR summation, the highest reported SAR was used as the most conservative evaluation for simultaneous transmission analysis.

FCC ID: ZNFUS110	 SAR EVALUATION REPORT 		Approved by: Quality Manager
Document S/N: 0Y1612232002-R2.ZNF	Test Dates: 12/21/16 - 01/05/17	DUT Type: Portable Handset	Page 41 of 50

12.3 Head SAR Simultaneous Transmission Analysis

Table 12-2
Simultaneous Transmission Scenario with 2.4 GHz WLAN (Held to Ear)

Exposure Condition	Mode	CDMA/LTE SAR (W/kg)	2.4 GHz WLAN SAR (W/kg)	Σ SAR (W/kg)
Head SAR	Cell. CDMA/EVDO	0.619	0.970	1.589
	PCS CDMA/EVDO	1.112	0.970	See Table 12-3
	LTE Band 13	0.466	0.970	1.436
	LTE Band 5 (Cell)	0.494	0.970	1.464
	LTE Band 4 (AWS)	0.515	0.970	1.485
	LTE Band 2 (PCS)	0.742	0.970	See Table 12-3

Table 12-3
Simultaneous Transmission Scenario with 2.4 GHz WLAN (Held to Ear)

Simult Tx	Configuration	PCS CDMA SAR (W/kg)	2.4 GHz WLAN SAR (W/kg)	Σ SAR (W/kg)	SPLSR
Head SAR	Right Cheek	0.629	0.594	1.223	N/A
	Right Tilt	0.217	0.499	0.716	N/A
	Left Cheek	1.112	0.970	See Note 1	0.04
	Left Tilt	0.298	0.755	1.053	N/A

Simult Tx	Configuration	LTE Band 2 (PCS) SAR (W/kg)	2.4 GHz WLAN SAR (W/kg)	Σ SAR (W/kg)	SPLSR
Head SAR	Right Cheek	0.497	0.594	1.091	N/A
	Right Tilt	0.244	0.499	0.743	N/A
	Left Cheek	0.742	0.970	See Note 1	0.03
	Left Tilt	0.223	0.755	0.978	N/A

Note 1: No evaluation was performed to determine the aggregate 1g SAR for these configurations as the SPLS ratio between the antenna pairs was not greater than 0.04 per FCC KDB 447498 D01v06. See Section 12.6 for detailed SPLS ratio analysis.

12.4 Body-Worn Simultaneous Transmission Analysis

Table 12-4
Simultaneous Transmission Scenario with 2.4 GHz WLAN (Body-Worn at 1.0 cm)

Exposure Condition	Mode	CDMA/LTE SAR (W/kg)	2.4 GHz WLAN SAR (W/kg)	Σ SAR (W/kg)
Body-Worn	Cell. CDMA	0.921	0.187	1.108
	PCS CDMA	1.208	0.187	1.395
	LTE Band 13	0.598	0.187	0.785
	LTE Band 5 (Cell)	0.799	0.187	0.986
	LTE Band 4 (AWS)	1.227	0.187	1.414
	LTE Band 2 (PCS)	1.087	0.187	1.274



FCC ID: ZNFUS110		SAR EVALUATION REPORT		Approved by: Quality Manager
Document S/N: 0Y1612232002-R2.ZNF	Test Dates: 12/21/16 - 01/05/17	DUT Type: Portable Handset		Page 42 of 50

Table 12-5
Simultaneous Transmission Scenario with Bluetooth (Body-Worn at 1.0 cm)

Exposure Condition	Mode	CDMA/LTE SAR (W/kg)	Bluetooth SAR (W/kg)	Σ SAR (W/kg)
Body-Worn	Cell. CDMA	0.921	0.210	1.131
	PCS CDMA	1.208	0.210	1.418
	LTE Band 13	0.598	0.210	0.808
	LTE Band 5 (Cell)	0.799	0.210	1.009
	LTE Band 4 (AWS)	1.227	0.210	1.437
	LTE Band 2 (PCS)	1.087	0.210	1.297

Note: Bluetooth SAR was not required to be measured per FCC KDB 447498. Estimated SAR results were used in the above table to determine simultaneous transmission SAR test exclusion.

12.5 Hotspot SAR Simultaneous Transmission Analysis

Table 12-6
Simultaneous Transmission Scenario (2.4 GHz Hotspot at 1.0 cm)



Exposure Condition	Mode	EVDO/LTE SAR (W/kg)	2.4 GHz WLAN SAR (W/kg)	Σ SAR (W/kg)
Hotspot SAR	Cell. EVDO	0.885	0.187	1.072
	PCS EVDO	1.131	0.187	1.318
	LTE Band 13	0.598	0.187	0.785
	LTE Band 5 (Cell)	0.799	0.187	0.986
	LTE Band 4 (AWS)	1.227	0.187	1.414
	LTE Band 2 (PCS)	1.087	0.187	1.274

12.6 SPLSR Evaluation and Analysis

Per FCC KDB Publication 447498 D01v06, when the sum of the standalone transmitters is more than 1.6 W/kg, the SAR sum to peak locations can be analyzed to determine SAR distribution overlaps. When the SAR peak to location ratio (shown below) for each pair of antennas is ≤ 0.04 , simultaneous SAR evaluation is not required. The distance between the transmitters was calculated using the following formula.

$$\text{Distance}_{Tx1 - Tx2} = R_i = \sqrt{(x_1 - x_2)^2 + (y_1 - y_2)^2 + (z_1 - z_2)^2}$$

$$\text{SPLS Ratio} = \frac{(SAR_1 + SAR_2)^{1.5}}{R_i}$$

FCC ID: ZNFUS110		SAR EVALUATION REPORT		Approved by: Quality Manager
Document S/N: 0Y1612232002-R2.ZNF	Test Dates: 12/21/16 - 01/05/17	DUT Type: Portable Handset		Page 43 of 50

12.6.1 SPLSR Evaluation and Analysis

Table 12-7
Head Peak SAR Locations

Mode/Band	x (mm)	y (mm)	z (mm)	Reported SAR (W/kg)
2.4 GHz WLAN	17.50	317.23	-174.44	0.970
PCS CDMA	53.71	245.31	-167.02	1.112
LTE Band 2	47.25	252.35	-169.41	0.742

Table 12-8
Head SAR Sum to Peak Location Separation Ratio Calculations

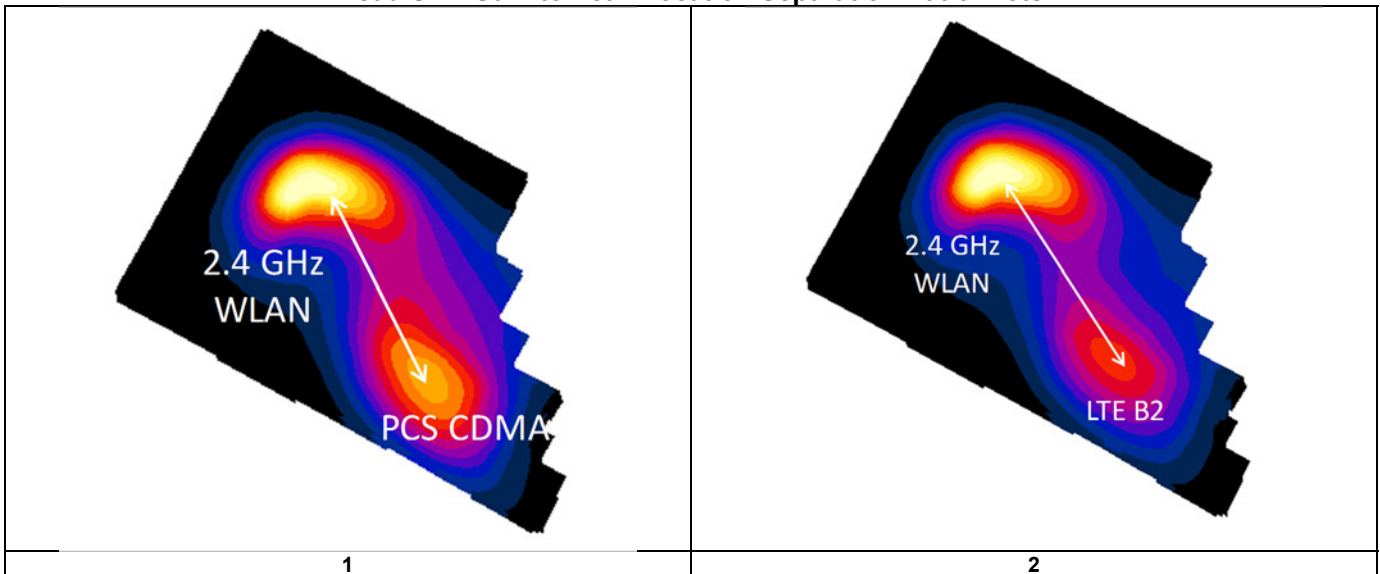

Antenna Pair		Standalone 1g SAR (W/kg)		Standalone SAR Sum (W/kg)	Peak SAR Separation Distance (mm)	SPLS Ratio	Plot Number
Ant "a"	Ant "b"	a	b	a+b	D _{a-b}	$(a+b)^{1.5}/D_{a-b}$	
PCS CDMA	2.4 GHz WLAN	1.112	0.970	2.082	80.86	0.04	1
LTE Band 2	2.4 GHz WLAN	0.742	0.970	1.712	71.55	0.03	2

Table 12-9
Head SAR Sum to Peak Location Separation Ratio Plots



12.7 Simultaneous Transmission Conclusion

The above numerical summed SAR and SPLSR results for all the worst-case simultaneous transmission conditions were below the SAR limit. Therefore, the above analysis is sufficient to determine that simultaneous transmission cases will not exceed the SAR limit and therefore no measured volumetric simultaneous SAR summation is required per FCC KDB Publication 447498 D01v06 and IEEE 1528-2013 Section 6.3.4.1.2.

FCC ID: ZNFUS110	 PCTEST ENGINEERING LABORATORY, INC.	SAR EVALUATION REPORT	 LG	Approved by: Quality Manager
Document S/N: 0Y1612232002-R2.ZNF	Test Dates: 12/21/16 - 01/05/17	DUT Type: Portable Handset		Page 44 of 50

13 SAR MEASUREMENT VARIABILITY

13.1 Measurement Variability

Per FCC KDB Publication 865664 D01v01r04, SAR measurement variability was assessed for each frequency band, which was determined by the SAR probe calibration point and tissue-equivalent medium used for the device measurements. When both head and body tissue-equivalent media were required for SAR measurements in a frequency band, the variability measurement procedures were applied to the tissue medium with the highest measured SAR, using the highest measured SAR configuration for that tissue-equivalent medium. These additional measurements were repeated after the completion of all measurements requiring the same head or body tissue-equivalent medium in a frequency band. The test device was returned to ambient conditions (normal room temperature) with the battery fully charged before it was re-mounted on the device holder for the repeated measurement(s) to minimize any unexpected variations in the repeated results.

SAR Measurement Variability was assessed using the following procedures for each frequency band:

- 1) When the original highest measured SAR is ≥ 0.80 W/kg, the measurement was repeated once.
- 2) A second repeated measurement was preformed only if the ratio of largest to smallest SAR for the original and first repeated measurements was > 1.20 or when the original or repeated measurement was ≥ 1.45 W/kg (~ 10% from the 1-g SAR limit).
- 3) A third repeated measurement was performed only if the original, first or second repeated measurement was ≥ 1.5 W/kg and the ratio of largest to smallest SAR for the original, first and second repeated measurements is > 1.20 .
- 4) Repeated measurements are not required when the original highest measured SAR is < 0.80 W/kg

**Table 13-1
Head SAR Measurement Variability Results**



HEAD VARIABILITY RESULTS														
Band	FREQUENCY		Mode/Band	Service	Side	Test Position	Data Rate (Mbps)	Measured SAR (1g)	1st Repeated SAR (1g)	Ratio	2nd Repeated SAR (1g)	Ratio	3rd Repeated SAR (1g)	Ratio
	MHz	Ch.						(W/kg)	(W/kg)		(W/kg)		(W/kg)	
2450	2437.00	6	802.11b, 22 MHz Bandwidth	DSSS	Left	Cheek	1	0.847	0.884	1.04	N/A	N/A	N/A	N/A
ANSI / IEEE C95.1 1992 - SAFETY LIMIT Spatial Peak Uncontrolled Exposure/General Population							Head 1.6 W/kg (mW/g) averaged over 1 gram							

**Table 13-2
Body SAR Measurement Variability Results**

BODY VARIABILITY RESULTS													
Band	FREQUENCY		Mode	Service	Side	Spacing	Measured SAR (1g)	1st Repeated SAR (1g)	Ratio	2nd Repeated SAR (1g)	Ratio	3rd Repeated SAR (1g)	Ratio
	MHz	Ch.					(W/kg)	(W/kg)		(W/kg)		(W/kg)	
835	836.52	384	Cell. CDMA	TDSO / SO32	back	10 mm	0.860	0.863	1.00	N/A	N/A	N/A	N/A
1750	1732.50	20175	LTE Band 4 (AWS), 20 MHz Bandwidth	QPSK, 1 RB, 99 RB Offset	back	10 mm	1.040	1.150	1.11	N/A	N/A	N/A	N/A
1900	1851.25	25	PCS CDMA	TDSO / SO32	back	10 mm	1.130	1.120	1.01	N/A	N/A	N/A	N/A
ANSI / IEEE C95.1 1992 - SAFETY LIMIT Spatial Peak Uncontrolled Exposure/General Population							Body 1.6 W/kg (mW/g) averaged over 1 gram						

13.2 Measurement Uncertainty



The measured SAR was < 1.5 W/kg for all frequency bands. Therefore, per KDB Publication 865664 D01v01r04, the extended measurement uncertainty analysis per IEEE 1528-2013 was not required.

FCC ID: ZNFUS110		SAR EVALUATION REPORT			Approved by: Quality Manager
Document S/N: 0Y1612232002-R2.ZNF	Test Dates: 12/21/16 - 01/05/17	DUT Type: Portable Handset		Page 45 of 50	

14 EQUIPMENT LIST



Manufacturer	Model	Description	Cal Date	Cal Interval	Cal Due	Serial Number
Agilent	E8257D	(250kHz-20GHz) Signal Generator	3/2/2016	Annual	3/2/2017	MY45470194
Agilent	8753E	(30kHz-6GHz) Network Analyzer	3/2/2016	Annual	3/2/2017	JP38020182
SPEAG	D1900V2	1900 MHz SAR Dipole	7/15/2016	Annual	7/15/2017	5d149
SPEAG	D2450V2	2450 MHz SAR Dipole	7/25/2016	Annual	7/25/2017	981
MCL	BW-N6W5+	6dB Attenuator	CBT	N/A	CBT	1139
SPEAG	D750V3	750 MHz Dipole	3/16/2016	Annual	3/16/2017	1054
SPEAG	D835V2	835 MHz SAR Dipole	7/13/2016	Annual	7/13/2017	4d047
Agilent	E5515C	8960 Series 10 Wireless Communications Test Set	10/5/2016	Annual	10/5/2017	GB42230325
Amplifier Research	15S1G6	Amplifier	CBT	N/A	CBT	433971
Narda	4772-3	Attenuator (3dB)	CBT	N/A	CBT	9406
Rohde & Schwarz	CMU200	Base Station Simulator	12/12/2016	Annual	12/12/2017	833855/0010
Pasternack	PE2208-6	Bidirectional Coupler	CBT	N/A	CBT	N/A
SPEAG	DAE4	Dasy Data Acquisition Electronics	2/19/2016	Annual	2/19/2017	665
SPEAG	DAE4	Dasy Data Acquisition Electronics	3/14/2016	Annual	3/14/2017	1368
SPEAG	DAE4	Dasy Data Acquisition Electronics	4/14/2016	Annual	4/14/2017	1407
SPEAG	DAE4	Dasy Data Acquisition Electronics	5/11/2016	Annual	5/11/2017	859
SPEAG	DAE4	Dasy Data Acquisition Electronics	8/22/2016	Annual	8/22/2017	1364
SPEAG	DAE4	Dasy Data Acquisition Electronics	9/14/2016	Annual	9/14/2017	1408
Mini-Circuits	BW-N20W5+	DC to 18 GHz Precision Fixed 20 dB Attenuator	CBT	N/A	CBT	N/A
SPEAG	DAK-3.5	Dielectric Assessment Kit	9/13/2016	Annual	9/13/2017	1091
SPEAG	DAK-12	Dielectric Assessment Kit (10MHz - 3GHz)	3/1/2016	Annual	3/1/2017	1102
Mitutoyo	CD-6°CSX	Digital Caliper	3/2/2016	Biennial	3/2/2018	13264165
Control Company	4040	Digital Thermometer	3/15/2015	Biennial	3/15/2017	150194929
Keysight	772D	Dual Directional Coupler	CBT	N/A	CBT	MY52180215
Agilent	E4438C	ESG Vector Signal Generator	2/27/2016	Annual	2/27/2017	MY45091346
Agilent	E4432B	ESG-D Series Signal Generator	3/5/2016	Annual	3/5/2017	US40053896
Control Company	4353	Long Stem Thermometer	1/22/2015	Biennial	1/22/2017	150053081
MiniCircuits	SLP-2400+	Low Pass Filter	CBT	N/A	CBT	R8979500903
Mini-Circuits	NLP-1200+	Low Pass Filter DC to 1000 MHz	CBT	N/A	CBT	N/A
Mini-Circuits	NLP-2950+	Low Pass Filter DC to 2700 MHz	CBT	N/A	CBT	N/A
Agilent	N5182A	MXG Vector Signal Generator	10/27/2016	Annual	10/27/2017	MY47420603
SPEAG	DAKS-3.5	Portable Dielectric Assessment Kit	8/25/2016	Annual	8/25/2017	1041
Mini-Circuits	BW-N20W5	Power Attenuator	CBT	N/A	CBT	1226
Anritsu	ML2495A	Power Meter	10/16/2015	Biennial	10/16/2017	941001
Anritsu	ML2495A	Power Meter	10/16/2015	Biennial	10/16/2017	1039008
Anritsu	ML2496A	Power Meter	2/28/2016	Annual	2/28/2017	1306009
Anritsu	ML2496A	Power Meter	3/5/2016	Annual	3/5/2017	1351001
Anritsu	MA2411B	Pulse Power Sensor	8/18/2016	Annual	8/18/2017	1126066
Anritsu	MA2411B	Pulse Power Sensor	8/18/2016	Annual	8/18/2017	1207470
Anritsu	MT8820C	Radio Communication Analyzer	4/14/2016	Annual	4/14/2017	6201240328
Rohde & Schwarz	CMW500	Radio Communication Tester	10/20/2016	Annual	10/20/2017	100976
SPEAG	D1750V2	SAR Dipole	5/9/2016	Annual	5/9/2017	1148
SPEAG	ES3DV3	SAR Probe	3/18/2016	Annual	3/18/2017	3319
SPEAG	EX3DV4	SAR Probe	4/19/2016	Annual	4/19/2017	7406
SPEAG	EX3DV4	SAR Probe	5/17/2016	Annual	5/17/2017	7409
SPEAG	ES3DV3	SAR Probe	9/19/2016	Annual	9/19/2017	3287
SPEAG	ES3DV3	SAR Probe	2/19/2016	Annual	2/19/2017	3318
SPEAG	ES3DV3	SAR Probe	3/18/2016	Annual	3/18/2017	3209
COMTECH	AR85729-5/5759B	Solid State Amplifier	CBT	N/A	CBT	M3W1A00-1002
Agilent	8753ES	S-Parameter Network Analyzer	3/3/2016	Annual	3/3/2017	US39170122
Agilent	8753ES	S-Parameter Vector Network Analyzer	8/19/2016	Annual	8/19/2017	MY40003841
Pasternack	NC-100	Torque Wrench	11/6/2015	Biennial	11/6/2017	N/A
Seekonk	NC-100	Torque Wrench (8" lb)	8/30/2016	Biennial	8/30/2018	N/A
Control Company	4352	Ultra Long Stem Thermometer	3/8/2016	Biennial	3/8/2018	160261728
Anritsu	MA24106A	USB Power Sensor	3/4/2016	Annual	3/4/2017	1344555
Anritsu	MA24106A	USB Power Sensor	3/4/2016	Annual	3/4/2017	1344556
Rohde & Schwarz	CMW500	Wideband Radio Communication Tester	7/20/2016	Annual	7/20/2017	132885
Agilent	E5515C	Wireless Communications Test Set	5/16/2015	Biennial	5/16/2017	GB43304447

Note: CBT (Calibrated Before Testing). Prior to testing, the measurement paths containing a cable, amplifier, attenuator, coupler or filter were connected to a calibrated source (i.e. a signal generator) to determine the losses of the measurement path. The power meter offset was then adjusted to compensate for the measurement system losses. This level offset is stored within the power meter before measurements are made. This calibration verification procedure applies to the system verification and output power measurements. The calibrated reading is then taken directly from the power meter after compensation of the losses for all final power measurements.

FCC ID: ZNFUS110		SAR EVALUATION REPORT		Approved by: Quality Manager
Document S/N: 0Y1612232002-R2.ZNF	Test Dates: 12/21/16 - 01/05/17	DUT Type: Portable Handset		Page 46 of 50

15 MEASUREMENT UNCERTAINTIES

a	c	d	e= f(d,k)	f	g	h = c x f/e	i = c x g/e	k
Uncertainty Component	Tol. (± %)	Prob. Dist.	Div.	c _i 1gm	c _i 10 gms	1gm u _i (± %)	10gms u _i (± %)	v _i
Measurement System								
Probe Calibration	6.55	N	1	1.0	1.0	6.6	6.6	∞
Axial Isotropy	0.25	N	1	0.7	0.7	0.2	0.2	∞
Hemishperical Isotropy	1.3	N	1	0.7	0.7	0.9	0.9	∞
Boundary Effect	2.0	R	1.73	1.0	1.0	1.2	1.2	∞
Linearity	0.3	N	1	1.0	1.0	0.3	0.3	∞
System Detection Limits	0.25	R	1.73	1.0	1.0	0.1	0.1	∞
Readout Electronics	0.3	N	1	1.0	1.0	0.3	0.3	∞
Response Time	0.8	R	1.73	1.0	1.0	0.5	0.5	∞
Integration Time	2.6	R	1.73	1.0	1.0	1.5	1.5	∞
RF Ambient Conditions - Noise	3.0	R	1.73	1.0	1.0	1.7	1.7	∞
RF Ambient Conditions - Reflections	3.0	R	1.73	1.0	1.0	1.7	1.7	∞
Probe Positioner Mechanical Tolerance	0.4	R	1.73	1.0	1.0	0.2	0.2	∞
Probe Positioning w/ respect to Phantom	6.7	R	1.73	1.0	1.0	3.9	3.9	∞
Extrapolation, Interpolation & Integration algorithms for Max. SAR Evaluation	4.0	R	1.73	1.0	1.0	2.3	2.3	∞
Test Sample Related								
Test Sample Positioning	2.7	N	1	1.0	1.0	2.7	2.7	35
Device Holder Uncertainty	1.67	N	1	1.0	1.0	1.7	1.7	5
Output Power Variation - SAR drift measurement	5.0	R	1.73	1.0	1.0	2.9	2.9	∞
SAR Scaling	0.0	R	1.73	1.0	1.0	0.0	0.0	∞
Phantom & Tissue Parameters								
Phantom Uncertainty (Shape & Thickness tolerances)	7.6	R	1.73	1.0	1.0	4.4	4.4	∞
Liquid Conductivity - measurement uncertainty	4.2	N	1	0.78	0.71	3.3	3.0	10
Liquid Permittivity - measurement uncertainty	4.1	N	1	0.23	0.26	1.0	1.1	10
Liquid Conductivity - Temperature Uncertainty	3.4	R	1.73	0.78	0.71	1.5	1.4	∞
Liquid Permittivity - Temperature Uncertainty	0.6	R	1.73	0.23	0.26	0.1	0.1	∞
Liquid Conductivity - deviation from target values	5.0	R	1.73	0.64	0.43	1.8	1.2	∞
Liquid Permittivity - deviation from target values	5.0	R	1.73	0.60	0.49	1.7	1.4	∞
Combined Standard Uncertainty (k=1)	RSS					11.5	11.3	60
Expanded Uncertainty (95% CONFIDENCE LEVEL)	k=2					23.0	22.6	



FCC ID: ZNFUS110		SAR EVALUATION REPORT		Approved by: Quality Manager
Document S/N: 0Y1612232002-R2.ZNF	Test Dates: 12/21/16 - 01/05/17	DUT Type: Portable Handset		Page 47 of 50

16 CONCLUSION

16.1 Measurement Conclusion



The SAR evaluation indicates that the EUT complies with the RF radiation exposure limits of the FCC and Innovation, Science, and Economic Development Canada, with respect to all parameters subject to this test. These measurements were taken to simulate the RF effects of RF exposure under worst-case conditions. Precise laboratory measures were taken to assure repeatability of the tests. The results and statements relate only to the item(s) tested.

Please note that the absorption and distribution of electromagnetic energy in the body are very complex phenomena that depend on the mass, shape, and size of the body, the orientation of the body with respect to the field vectors, and the electrical properties of both the body and the environment. Other variables that may play a substantial role in possible biological effects are those that characterize the environment (e.g. ambient temperature, air velocity, relative humidity, and body insulation) and those that characterize the individual (e.g. age, gender, activity level, debilitation, or disease). Because various factors may interact with one another to vary the specific biological outcome of an exposure to electromagnetic fields, any protection guide should consider maximal amplification of biological effects as a result of field-body interactions, environmental conditions, and physiological variables. [3]



FCC ID: ZNFUS110		SAR EVALUATION REPORT		Approved by: Quality Manager
Document S/N: 0Y1612232002-R2.ZNF	Test Dates: 12/21/16 - 01/05/17	DUT Type: Portable Handset	Page 48 of 50	

17 REFERENCES

- [1] Federal Communications Commission, ET Docket 93-62, Guidelines for Evaluating the Environmental Effects of Radiofrequency Radiation, Aug. 1996.
- [2] ANSI/IEEE C95.1-2005, American National Standard safety levels with respect to human exposure to radio frequency electromagnetic fields, 3kHz to 300GHz, New York: IEEE, 2006.
- [3] ANSI/IEEE C95.1-1992, American National Standard safety levels with respect to human exposure to radio frequency electromagnetic fields, 3kHz to 300GHz, New York: IEEE, Sept. 1992.
- [4] ANSI/IEEE C95.3-2002, IEEE Recommended Practice for the Measurement of Potentially Hazardous Electromagnetic Fields - RF and Microwave, New York: IEEE, December 2002.
- [5] IEEE Standards Coordinating Committee 39 –Standards Coordinating Committee 34 – IEEE Std. 1528-2013, IEEE Recommended Practice for Determining the Peak Spatial-Average Specific Absorption Rate (SAR) in the Human Head from Wireless Communications Devices: Measurement Techniques.
- [6] NCRP, National Council on Radiation Protection and Measurements, Biological Effects and Exposure Criteria for RadioFrequency Electromagnetic Fields, NCRP Report No. 86, 1986. Reprinted Feb. 1995.
- [7] T. Schmid, O. Egger, N. Kuster, Automated E-field scanning system for dosimetric assessments, IEEE Transaction on Microwave Theory and Techniques, vol. 44, Jan. 1996, pp. 105-113.
- [8] K. Pokovic, T. Schmid, N. Kuster, Robust setup for precise calibration of E-field probes in tissue simulating liquids at mobile communications frequencies, ICECOM97, Oct. 1997, pp. 1 -124.
- [9] K. Pokovic, T. Schmid, and N. Kuster, E-field Probe with improved isotropy in brain simulating liquids, Proceedings of the ELMAR, Zadar, Croatia, June 23-25, 1996, pp. 172-175.
- [10] Schmid & Partner Engineering AG, Application Note: Data Storage and Evaluation, June 1998, p2.
- [11] V. Hombach, K. Meier, M. Burkhardt, E. Kuhn, N. Kuster, The Dependence of EM Energy Absorption upon Human Modeling at 900 MHz, IEEE Transaction on Microwave Theory and Techniques, vol. 44 no. 10, Oct. 1996, pp. 1865-1873.
- [12] N. Kuster and Q. Balzano, Energy absorption mechanism by biological bodies in the near field of dipole antennas above 300MHz, IEEE Transaction on Vehicular Technology, vol. 41, no. 1, Feb. 1992, pp. 17-23.
- [13] G. Hartsgrove, A. Kraszewski, A. Surowiec, Simulated Biological Materials for Electromagnetic Radiation Absorption Studies, University of Ottawa, Bioelectromagnetics, Canada: 1987, pp. 29-36.
- [14] Q. Balzano, O. Garay, T. Manning Jr., Electromagnetic Energy Exposure of Simulated Users of Portable Cellular Telephones, IEEE Transactions on Vehicular Technology, vol. 44, no.3, Aug. 1995.
- [15] W. Gander, Computermathematick, Birkhaeuser, Basel, 1992.
- [16] W.H. Press, S.A. Teukolsky, W.T. Vetterling, and B.P. Flannery, Numerical Recipes in C, The Art of Scientific Computing, Second edition, Cambridge University Press, 1992.
- [17] N. Kuster, R. Kastle, T. Schmid, Dosimetric evaluation of mobile communications equipment with known precision, IEEE Transaction on Communications, vol. E80-B, no. 5, May 1997, pp. 645-652.

FCC ID: ZNFUS110		SAR EVALUATION REPORT		Approved by: Quality Manager
Document S/N: 0Y1612232002-R2.ZNF	Test Dates: 12/21/16 - 01/05/17	DUT Type: Portable Handset	Page 49 of 50	

- [18] CENELEC CLC/SC111B, European Prestandard (prENV 50166-2), Human Exposure to Electromagnetic Fields High-frequency: 10kHz-300GHz, Jan. 1995.
- [19] Prof. Dr. Niels Kuster, ETH, Eidgenössische Technische Hochschule Zürich, Dosimetric Evaluation of the Cellular Phone.
- [20] IEC 62209-1, Human exposure to radio frequency fields from hand-held and body-mounted wireless communication devices - Human models, instrumentation, and procedures - Part 1: Procedure to determine the specific absorption rate (SAR) for hand-held devices used in close proximity to the ear (frequency range of 300 MHz to 3 GHz), Feb. 2005.
- [21] Innovation, Science, Economic Development Canada RSS-102 Radio Frequency Exposure Compliance of Radiocommunication Apparatus (All Frequency Bands) Issue 5, March 2015.
- [22] Health Canada Safety Code 6 Limits of Human Exposure to Radio Frequency Electromagnetic Fields in the Frequency Range from 3 kHz – 300 GHz, 2015
- [23] FCC SAR Test Procedures for 2G-3G Devices, Mobile Hotspot and UMPC Devices KDB Publications 941225, D01-D07
- [24] SAR Measurement Guidance for IEEE 802.11 Transmitters, KDB Publication 248227 D01
- [25] FCC SAR Considerations for Handsets with Multiple Transmitters and Antennas, KDB Publications 648474 D03-D04
- [26] FCC SAR Evaluation Considerations for Laptop, Notebook, Netbook and Tablet Computers, FCC KDB Publication 616217 D04
- [27] FCC SAR Measurement and Reporting Requirements for 100MHz – 6 GHz, KDB Publications 865664 D01-D02
- [28] FCC General RF Exposure Guidance and SAR Procedures for Dongles, KDB Publication 447498, D01-D02
- [29] Anexo à Resolução No. 533, de 10 de Setembro de 2009.
- [30] IEC 62209-2, Human exposure to radio frequency fields from hand-held and body-mounted wireless communication devices - Human models, instrumentation, and procedures - Part 2: Procedure to determine the specific absorption rate (SAR) for wireless communication devices used in close proximity to the human body (frequency range of 30 MHz to 6 GHz), Mar. 2010.

FCC ID: ZNFUS110	 SAR EVALUATION REPORT 		Approved by: Quality Manager
Document S/N: 0Y1612232002-R2.ZNF	Test Dates: 12/21/16 - 01/05/17	DUT Type: Portable Handset	Page 50 of 50

APPENDIX A: SAR TEST DATA

PCTEST ENGINEERING LABORATORY, INC.

DUT: ZNFUS110; Type: Portable Handset; Serial: 01321

Communication System: UID 0, CDMA; Frequency: 836.52 MHz; Duty Cycle: 1:1
Medium: 835 Head Medium parameters used (interpolated):
 $f = 836.52 \text{ MHz}$; $\sigma = 0.906 \text{ S/m}$; $\epsilon_r = 41.345$; $\rho = 1000 \text{ kg/m}^3$
Phantom section: Right Section

Test Date: 12-22-2016; Ambient Temp: 22.7°C; Tissue Temp: 21.5°C

Probe: EX3DV4 - SN7406; ConvF(9.83, 9.83, 9.83); Calibrated: 4/19/2016;
Sensor-Surface: 1.4mm (Mechanical Surface Detection)
Electronics: DAE4 Sn1407; Calibrated: 4/14/2016
Phantom: SAM 5.0 front; Type: QD000P40CD; Serial: TP:-1648
Measurement SW: DASY52, Version 52.8 (8); SEMCAD X Version 14.6.10 (7331)

Mode: Cell. EVDO Rev. A, Rule Part 22H, Right Head, Cheek, Mid.ch

Area Scan (9x15x1): Measurement grid: $dx=15\text{mm}$, $dy=15\text{mm}$

Zoom Scan (5x5x7)/Cube 0: Measurement grid: $dx=8\text{mm}$, $dy=8\text{mm}$, $dz=5\text{mm}$

Reference Value = 26.21 V/m; Power Drift = 0.03 dB

Peak SAR (extrapolated) = 0.761 W/kg

SAR(1 g) = 0.583 W/kg

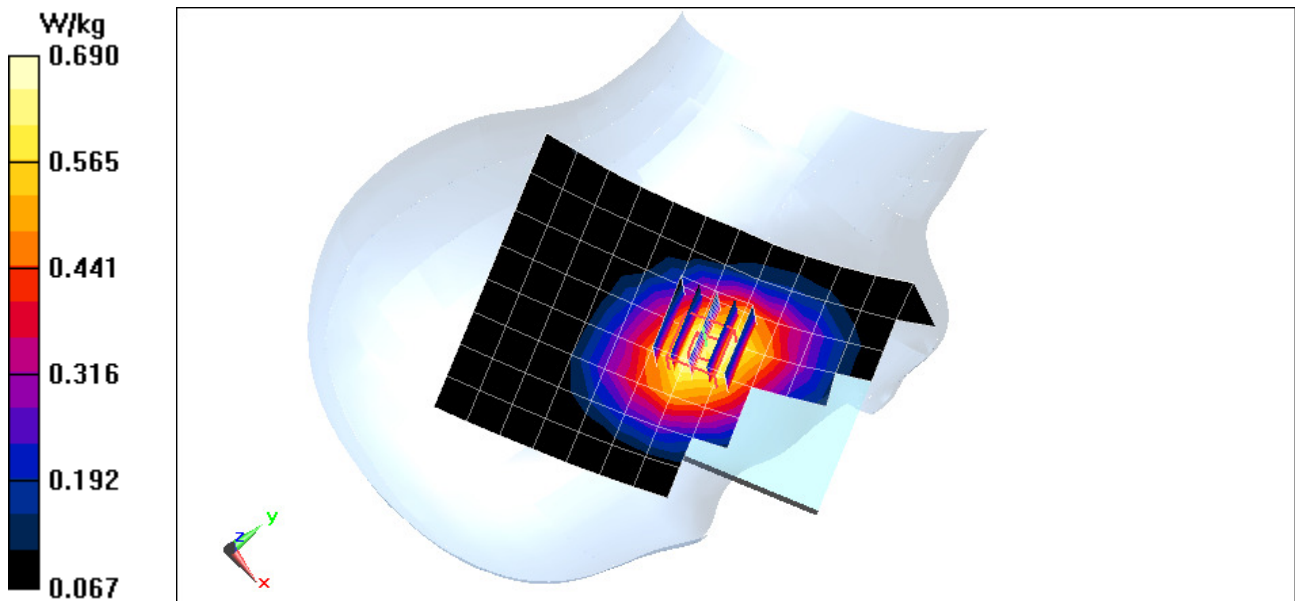

PCTEST ENGINEERING LABORATORY, INC.

DUT: ZNFUS110; Type: Portable Handset; Serial: 01321

Communication System: UID 0, PCS CDMA; Frequency: 1908.75 MHz; Duty Cycle: 1:1
Medium: 1900 Head Medium parameters used:
 $f = 1908.75 \text{ MHz}$; $\sigma = 1.454 \text{ S/m}$; $\epsilon_r = 39.008$; $\rho = 1000 \text{ kg/m}^3$
Phantom section: Left Section

Test Date: 12-26-2016; Ambient Temp: 23.3°C; Tissue Temp: 22.0°C

Probe: ES3DV3 - SN3287; ConvF(5.27, 5.27, 5.27); Calibrated: 9/19/2016;
Sensor-Surface: 3mm (Mechanical Surface Detection)
Electronics: DAE4 Sn1408; Calibrated: 9/14/2016
Phantom: SAM Front; Type: SAM; Serial: 1686
Measurement SW: DASY52, Version 52.8 (8); SEMCAD X Version 14.6.10 (7331)

Mode: PCS CDMA, Left Head, Cheek, High.ch

Area Scan (8x14x1): Measurement grid: dx=15mm, dy=15mm

Zoom Scan (6x6x7)/Cube 0: Measurement grid: dx=8mm, dy=8mm, dz=5mm

Reference Value = 27.09 V/m; Power Drift = 0.07 dB

Peak SAR (extrapolated) = 2.26 W/kg

SAR(1 g) = 1.05 W/kg

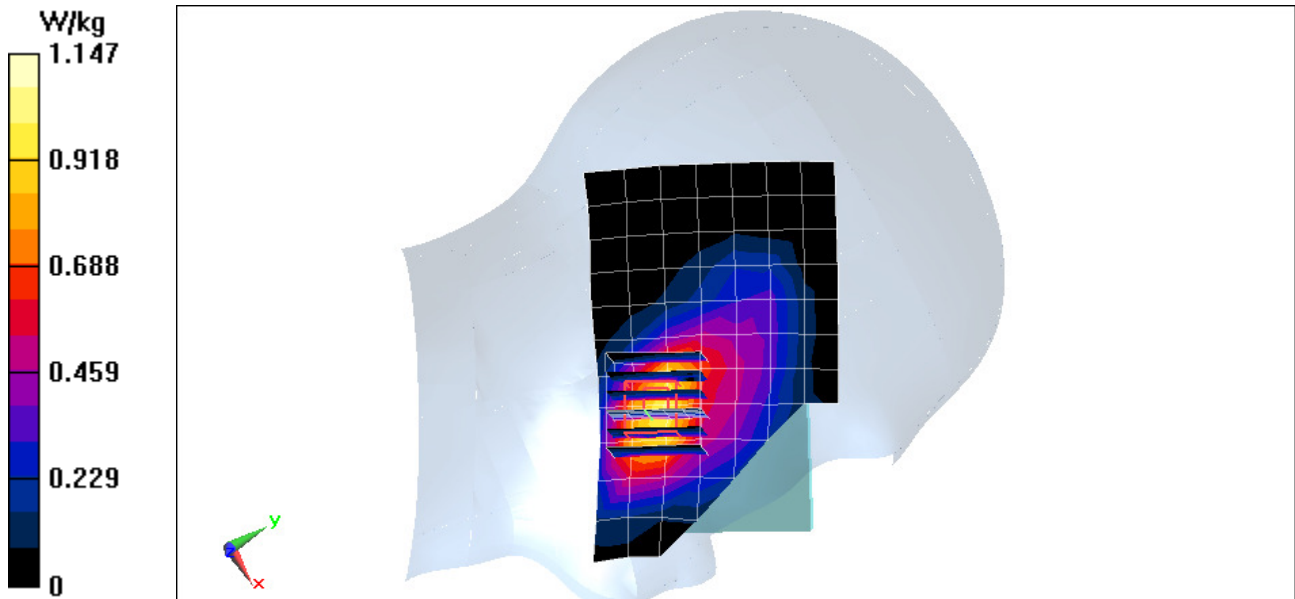

PCTEST ENGINEERING LABORATORY, INC.

DUT: ZNFUS110; Type: Portable Handset; Serial: 01339

Communication System: UID 0, LTE Band 13; Frequency: 782 MHz; Duty Cycle: 1:1
Medium: 750 Head Medium parameters used (interpolated):
 $f = 782 \text{ MHz}$; $\sigma = 0.934 \text{ S/m}$; $\epsilon_r = 41.864$; $\rho = 1000 \text{ kg/m}^3$
Phantom section: Right Section

Test Date: 12-22-2016; Ambient Temp: 23.7°C; Tissue Temp: 21.9°C

Probe: ES3DV3 - SN3287; ConvF(6.96, 6.96, 6.96); Calibrated: 9/19/2016;
Sensor-Surface: 3mm (Mechanical Surface Detection)
Electronics: DAE4 Sn1408; Calibrated: 9/14/2016
Phantom: SAM Front; Type: SAM; Serial: 1686
Measurement SW: DASY52, Version 52.8 (8); SEMCAD X Version 14.6.10 (7331)

**Mode: LTE Band 13, Right Head, Cheek, Mid.ch,
10 MHz Bandwidth, QPSK, 1 RB, 0 RB Offset**

Area Scan (9x13x1): Measurement grid: $dx=15\text{mm}$, $dy=15\text{mm}$
Zoom Scan (5x5x7)/Cube 0: Measurement grid: $dx=8\text{mm}$, $dy=8\text{mm}$, $dz=5\text{mm}$
Reference Value = 23.20 V/m; Power Drift = -0.04 dB
Peak SAR (extrapolated) = 0.573 W/kg
SAR(1 g) = 0.438 W/kg

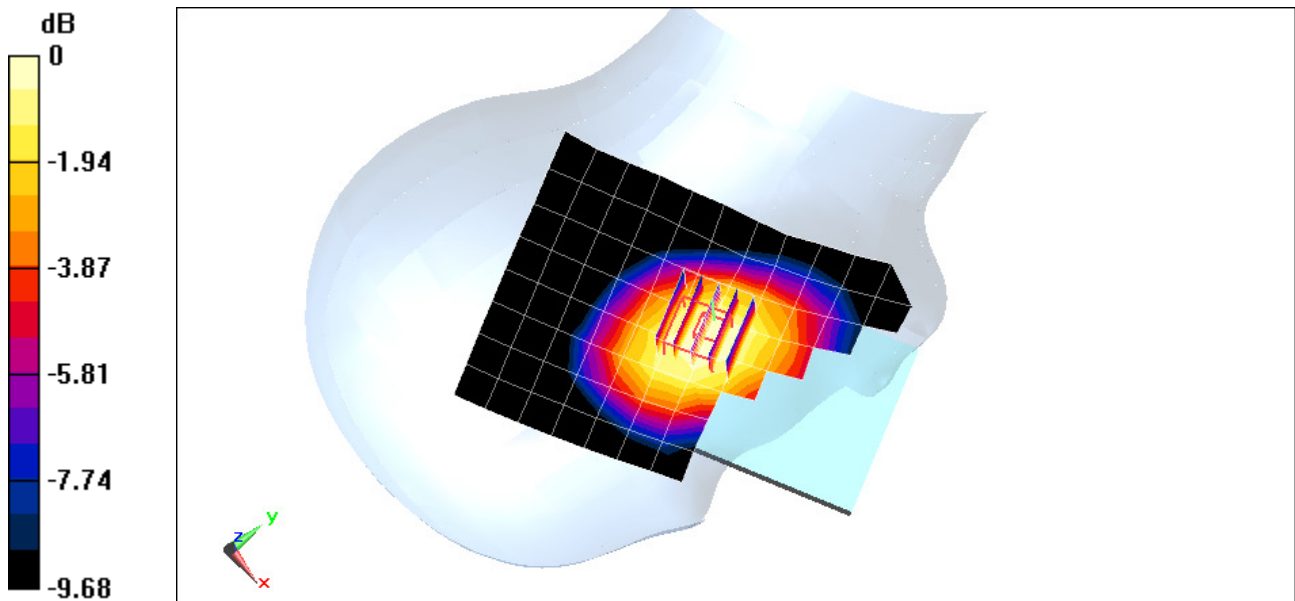

0 dB = 0.486 W/kg = -3.13 dBW/kg

PCTEST ENGINEERING LABORATORY, INC.

DUT: ZNFUS110; Type: Portable Handset; Serial: 01339

Communication System: UID 0, LTE Band 5 (Cell.); Frequency: 836.5 MHz; Duty Cycle: 1:1
Medium: 835 Head Medium parameters used (interpolated):
 $f = 836.5 \text{ MHz}$; $\sigma = 0.906 \text{ S/m}$; $\epsilon_r = 41.345$; $\rho = 1000 \text{ kg/m}^3$
Phantom section: Right Section

Test Date: 12-22-2016; Ambient Temp: 22.7°C; Tissue Temp: 21.5°C

Probe: EX3DV4 - SN7406; ConvF(9.83, 9.83, 9.83); Calibrated: 4/19/2016;
Sensor-Surface: 1.4mm (Mechanical Surface Detection)
Electronics: DAE4 Sn1407; Calibrated: 4/14/2016
Phantom: SAM 5.0 front; Type: QD000P40CD; Serial: TP:-1648
Measurement SW: DASY52, Version 52.8 (8); SEMCAD X Version 14.6.10 (7331)

**Mode: LTE Band 5 (Cell.), Right Head, Cheek, Mid.ch,
10 MHz Bandwidth, QPSK, 1 RB, 25 RB Offset**

Area Scan (9x13x1): Measurement grid: $dx=15\text{mm}$, $dy=15\text{mm}$
Zoom Scan (8x7x7)/Cube 0: Measurement grid: $dx=8\text{mm}$, $dy=8\text{mm}$, $dz=5\text{mm}$
Reference Value = 24.10 V/m; Power Drift = -0.17 dB
Peak SAR (extrapolated) = 0.605 W/kg
SAR(1 g) = 0.481 W/kg

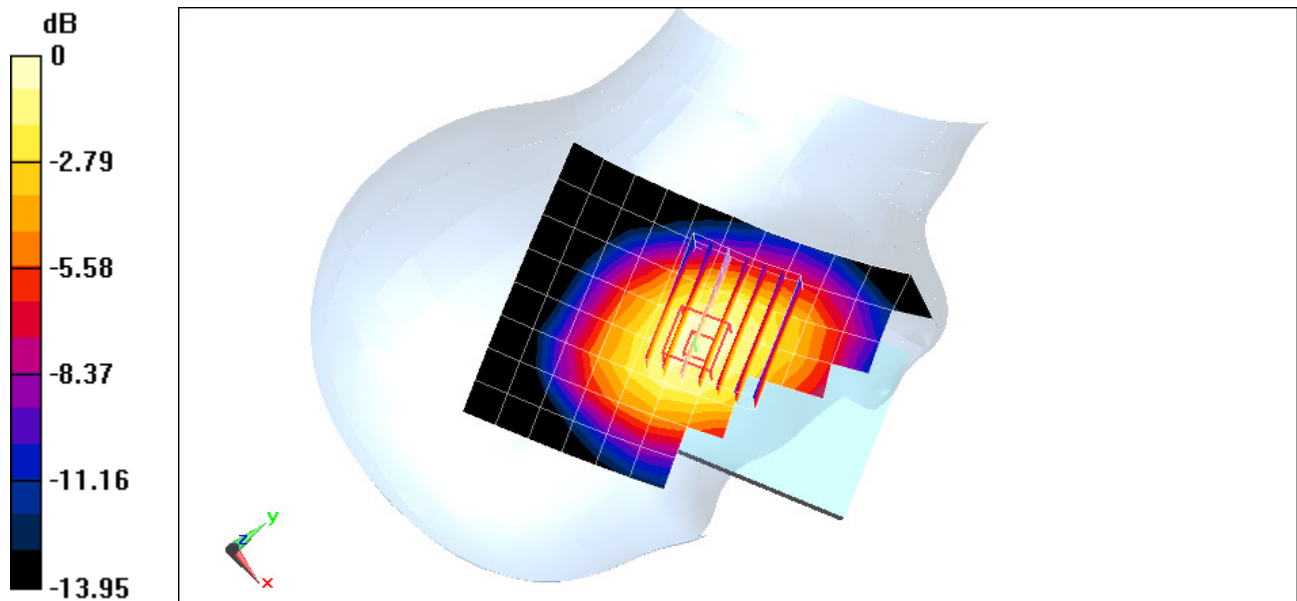

0 dB = 0.571 W/kg = -2.43 dBW/kg

PCTEST ENGINEERING LABORATORY, INC.

DUT: ZNFUS110; Type: Portable Handset; Serial: 01339

Communication System: UID 0, LTE Band 4 (AWS); Frequency: 1732.5 MHz; Duty Cycle: 1:1
Medium: 1750 Head Medium parameters used (interpolated):
 $f = 1732.5$ MHz; $\sigma = 1.363$ S/m; $\epsilon_r = 40.79$; $\rho = 1000$ kg/m³
Phantom section: Left Section

Test Date: 12-24-2016; Ambient Temp: 23.0°C; Tissue Temp: 21.6°C

Probe: EX3DV4 - SN7406; ConvF(8.85, 8.85, 8.85); Calibrated: 4/19/2016;
Sensor-Surface: 1.4mm (Mechanical Surface Detection)
Electronics: DAE4 Sn1407; Calibrated: 4/14/2016
Phantom: SAM 5.0 front; Type: QD000P40CD; Serial: TP:-1648
Measurement SW: DASY52, Version 52.8 (8); SEMCAD X Version 14.6.10 (7331)

**Mode: LTE Band 4 (AWS), Left Head, Cheek, Mid.ch,
20 MHz Bandwidth, QPSK, 1 RB, 99 RB Offset**

Area Scan (9x15x1): Measurement grid: dx=15mm, dy=15mm
Zoom Scan (5x5x7)/Cube 0: Measurement grid: dx=8mm, dy=8mm, dz=5mm
Reference Value = 20.87 V/m; Power Drift = 0.01 dB
Peak SAR (extrapolated) = 0.710 W/kg
SAR(1 g) = 0.483 W/kg

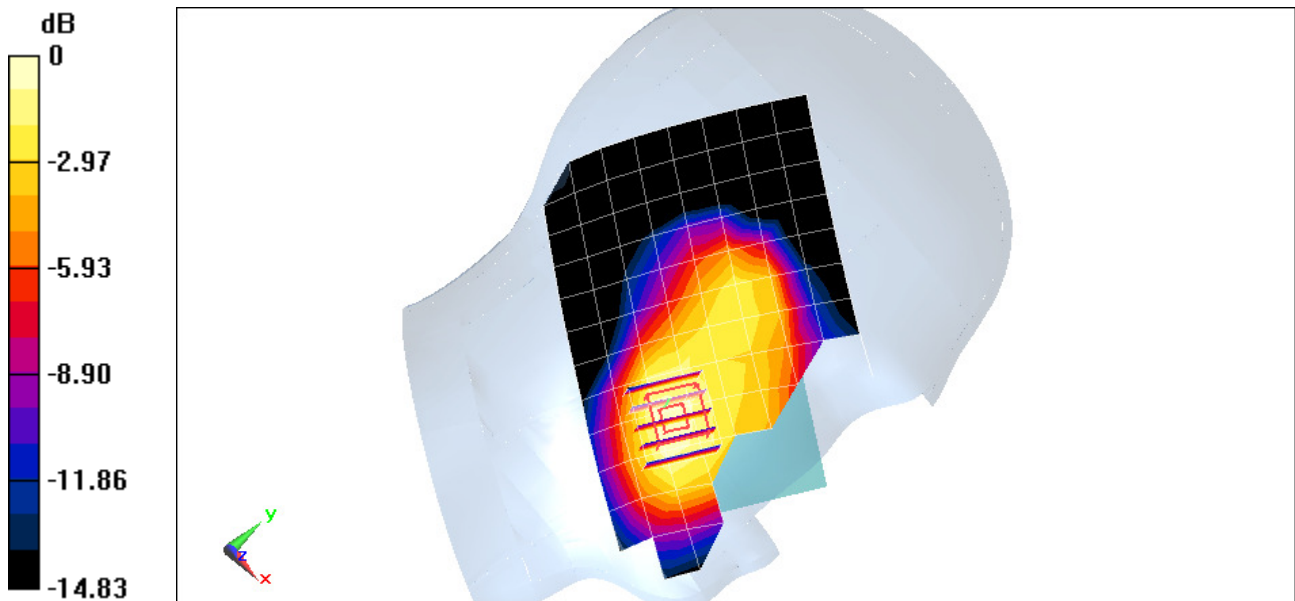

0 dB = 0.633 W/kg = -1.99 dBW/kg

PCTEST ENGINEERING LABORATORY, INC.

DUT: ZNFUS110; Type: Portable Handset; Serial: 01339

Communication System: UID 0, LTE Band 2 (PCS); Frequency: 1900 MHz; Duty Cycle: 1:1
Medium: 1900 Head Medium parameters used (interpolated):
 $f = 1900 \text{ MHz}$; $\sigma = 1.444 \text{ S/m}$; $\epsilon_r = 39.039$; $\rho = 1000 \text{ kg/m}^3$
Phantom section: Left Section

Test Date: 12-26-2016; Ambient Temp: 23.3°C; Tissue Temp: 22.0°C

Probe: ES3DV3 - SN3287; ConvF(5.27, 5.27, 5.27); Calibrated: 9/19/2016;
Sensor-Surface: 3mm (Mechanical Surface Detection)
Electronics: DAE4 Sn1408; Calibrated: 9/14/2016
Phantom: SAM Front; Type: SAM; Serial: 1686
Measurement SW: DASY52, Version 52.8 (8); SEMCAD X Version 14.6.10 (7331)

**Mode: LTE Band 2 (PCS), Left Head, Cheek, High.ch,
20 MHz Bandwidth, QPSK, 1 RB, 50 RB Offset**

Area Scan (8x13x1): Measurement grid: dx=15mm, dy=15mm
Zoom Scan (5x5x7)/Cube 0: Measurement grid: dx=8mm, dy=8mm, dz=5mm
Reference Value = 24.97 V/m; Power Drift = 0.04 dB
Peak SAR (extrapolated) = 1.19 W/kg
SAR(1 g) = 0.733 W/kg

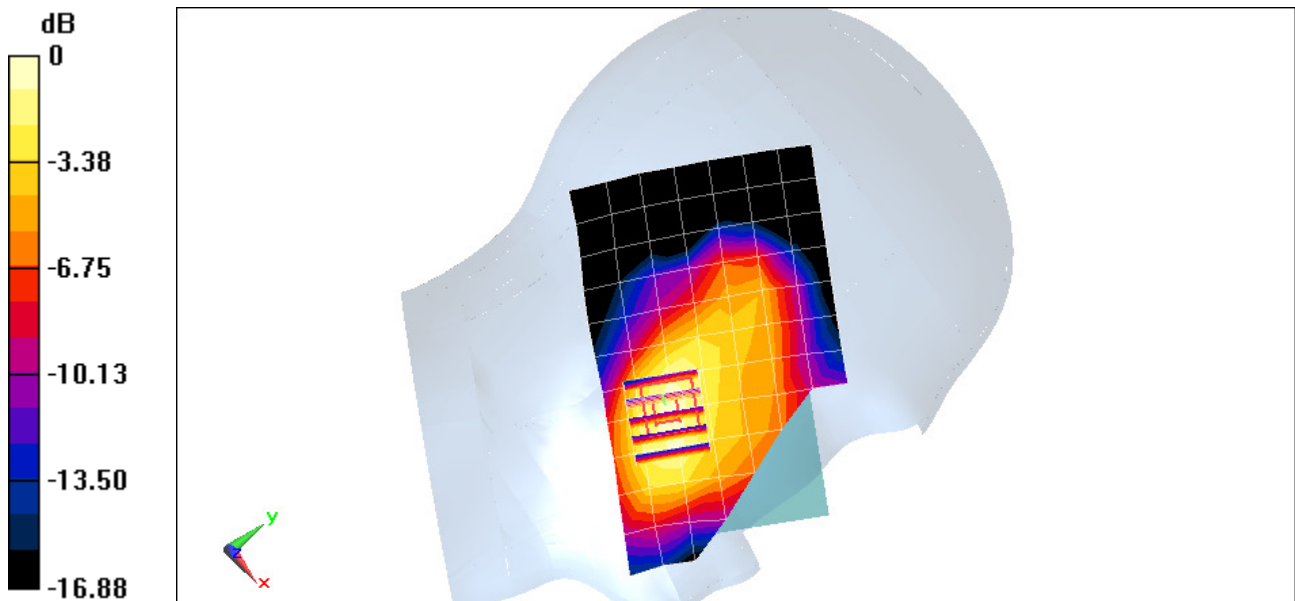

0 dB = 0.872 W/kg = -0.59 dBW/kg

PCTEST ENGINEERING LABORATORY, INC.

DUT: ZNFUS110; Type: Portable Handset; Serial: 01347

Communication System: UID 0, IEEE 802.11b; Frequency: 2437 MHz; Duty Cycle: 1:1
Medium: 2450 Head Medium parameters used (interpolated):
 $f = 2437 \text{ MHz}$; $\sigma = 1.87 \text{ S/m}$; $\epsilon_r = 38.156$; $\rho = 1000 \text{ kg/m}^3$
Phantom section: Left Section

Test Date: 12-27-2016; Ambient Temp: 21.0°C; Tissue Temp: 22.5°C

Probe: EX3DV4 - SN7406; ConvF(7.29, 7.29, 7.29); Calibrated: 4/19/2016;
Sensor-Surface: 1.4mm (Mechanical Surface Detection)
Electronics: DAE4 Sn1407; Calibrated: 4/14/2016
Phantom: SAM 5.0 front; Type: QD000P40CD; Serial: TP:-1648
Measurement SW: DASY52, Version 52.8 (8); SEMCAD X Version 14.6.10 (7331)

Mode: IEEE 802.11b, 22 MHz Bandwidth, Left Head, Cheek, Ch 6, 1 Mbps

Area Scan (10x17x1): Measurement grid: dx=12mm, dy=12mm

Zoom Scan (7x8x7)/Cube 0: Measurement grid: dx=5mm, dy=5mm, dz=5mm

Reference Value = 21.57 V/m; Power Drift = 0.00 dB

Peak SAR (extrapolated) = 1.74 W/kg

SAR(1 g) = 0.884 W/kg

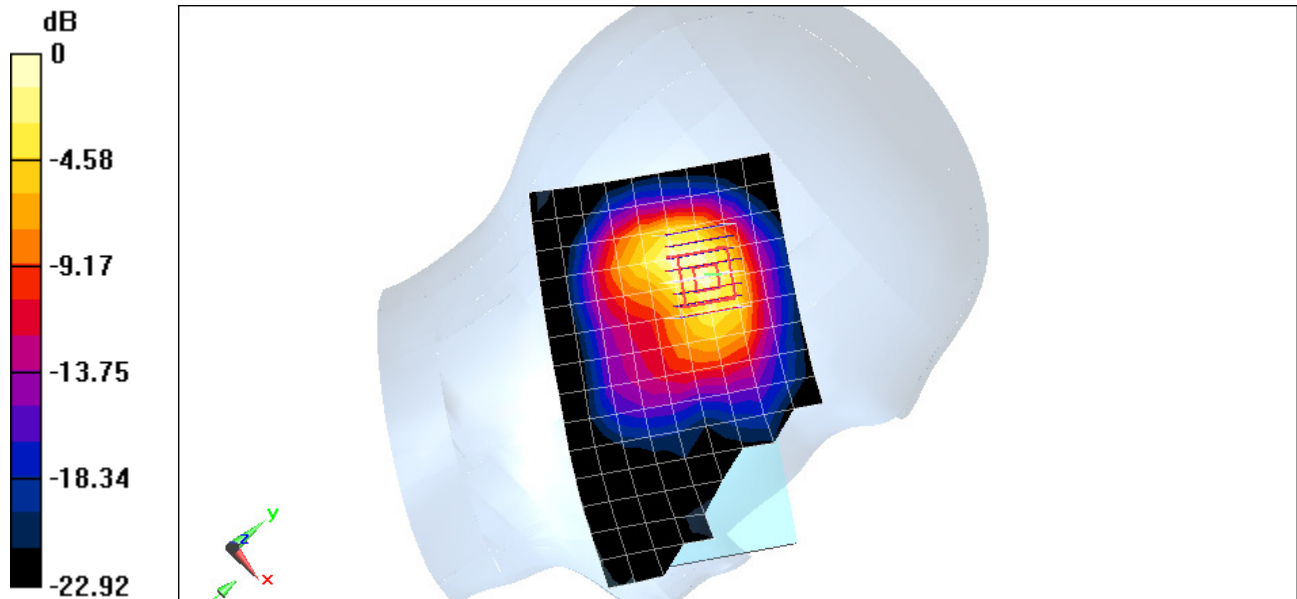

0 dB = 1.40 W/kg = 1.46 dBW/kg

PCTEST ENGINEERING LABORATORY, INC.

DUT: ZNFUS110; Type: Portable Handset; Serial: 01321

Communication System: UID 0, CDMA; Frequency: 836.52 MHz; Duty Cycle: 1:1
Medium: 835 Body Medium parameters used (interpolated):
 $f = 836.52 \text{ MHz}$; $\sigma = 1.014 \text{ S/m}$; $\epsilon_r = 54.112$; $\rho = 1000 \text{ kg/m}^3$
Phantom section: Flat Section; Space: 1.0 cm

Test Date: 01-05-2017; Ambient Temp: 23.2°C; Tissue Temp: 22.0°C

Probe: ES3DV3 - SN3319; ConvF(6.04, 6.04, 6.04); Calibrated: 3/18/2016;
Sensor-Surface: 3mm (Mechanical Surface Detection)
Electronics: DAE4 Sn1368; Calibrated: 3/14/2016
Phantom: SAM with CRP (Left); Type: SAM; Serial: 1715
Measurement SW: DASY52, Version 52.8 (8); SEMCAD X Version 14.6.10 (7331)

Mode: Cell. CDMA, Body SAR, Back side, Mid.ch

Area Scan (8x13x1): Measurement grid: $dx=15\text{mm}$, $dy=15\text{mm}$
Zoom Scan (5x5x7)/Cube 0: Measurement grid: $dx=8\text{mm}$, $dy=8\text{mm}$, $dz=5\text{mm}$
Reference Value = 21.90 V/m; Power Drift = 0.03 dB
Peak SAR (extrapolated) = 1.11 W/kg
SAR(1 g) = 0.874 W/kg

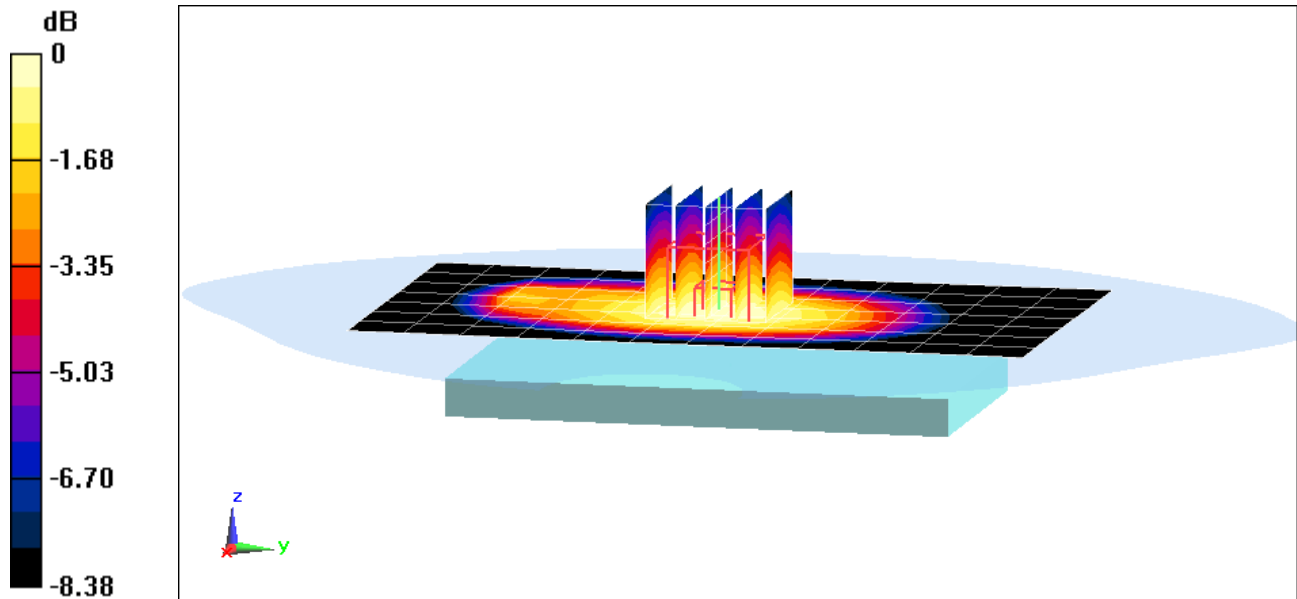

PCTEST ENGINEERING LABORATORY, INC.

DUT: ZNFUS110; Type: Portable Handset; Serial: 01321

Communication System: UID 0, CDMA; Frequency: 836.52 MHz; Duty Cycle: 1:1
Medium: 835 Body Medium parameters used (interpolated):
 $f = 836.52 \text{ MHz}$; $\sigma = 1 \text{ S/m}$; $\epsilon_r = 54.122$; $\rho = 1000 \text{ kg/m}^3$
Phantom section: Flat Section; Space: 1.0 cm

Test Date: 12-21-2016; Ambient Temp: 23.1°C; Tissue Temp: 22.2°C

Probe: ES3DV3 - SN3319; ConvF(6.04, 6.04, 6.04); Calibrated: 3/18/2016;
Sensor-Surface: 3mm (Mechanical Surface Detection)
Electronics: DAE4 Sn1368; Calibrated: 3/14/2016
Phantom: SAM with CRP (Left); Type: SAM; Serial: 1715
Measurement SW: DASY52, Version 52.8 (8); SEMCAD X Version 14.6.10 (7331)

Mode: Cell. EVDO Rev0, Body SAR, Back side, Mid.ch

Area Scan (8x13x1): Measurement grid: dx=15mm, dy=15mm
Zoom Scan (5x5x7)/Cube 0: Measurement grid: dx=8mm, dy=8mm, dz=5mm
Reference Value = 30.24 V/m; Power Drift = -0.09 dB
Peak SAR (extrapolated) = 1.07 W/kg
SAR(1 g) = 0.845 W/kg

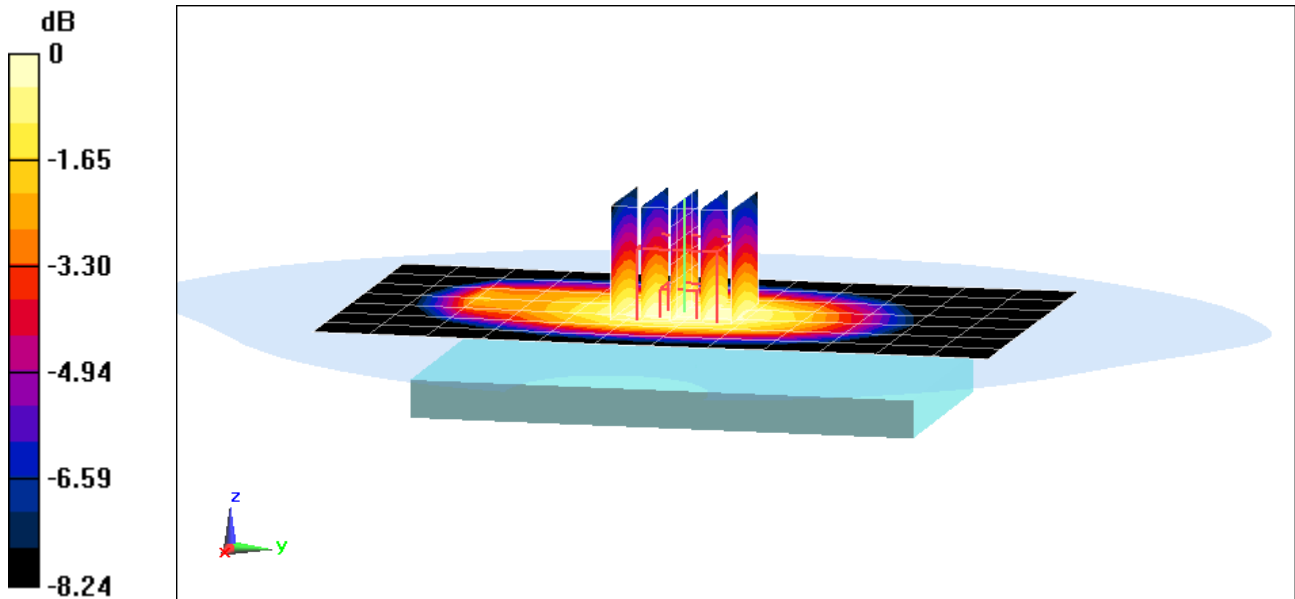

0 dB = 0.927 W/kg = -0.33 dBW/kg

PCTEST ENGINEERING LABORATORY, INC.

DUT: ZNFUS110; Type: Portable Handset; Serial: 01321

Communication System: UID 0, CDMA; Frequency: 1851.25 MHz; Duty Cycle: 1:1
Medium: 1900 Body Medium parameters used:
 $f = 1851.25$ MHz; $\sigma = 1.515$ S/m; $\epsilon_r = 51.969$; $\rho = 1000$ kg/m³
Phantom section: Flat Section; Space: 1.0 cm

Test Date: 12-23-2016; Ambient Temp: 22.9°C; Tissue Temp: 22.5°C

Probe: EX3DV4 - SN7409; ConvF(7.47, 7.47, 7.47); Calibrated: 5/17/2016;
Sensor-Surface: 1.4mm (Mechanical Surface Detection)
Electronics: DAE4 Sn859; Calibrated: 5/11/2016
Phantom: SAM Left; Type: QD000P40CC; Serial: TP: 1375
Measurement SW: DASY52, Version 52.8 (8); SEMCAD X Version 14.6.10 (7331)

Mode: PCS CDMA, Body SAR, Back side, Low.ch

Area Scan (8x13x1): Measurement grid: dx=15mm, dy=15mm
Zoom Scan (7x6x7)/Cube 0: Measurement grid: dx=8mm, dy=8mm, dz=5mm
Reference Value = 27.13 V/m; Power Drift = -0.03 dB
Peak SAR (extrapolated) = 1.79 W/kg
SAR(1 g) = 1.13 W/kg

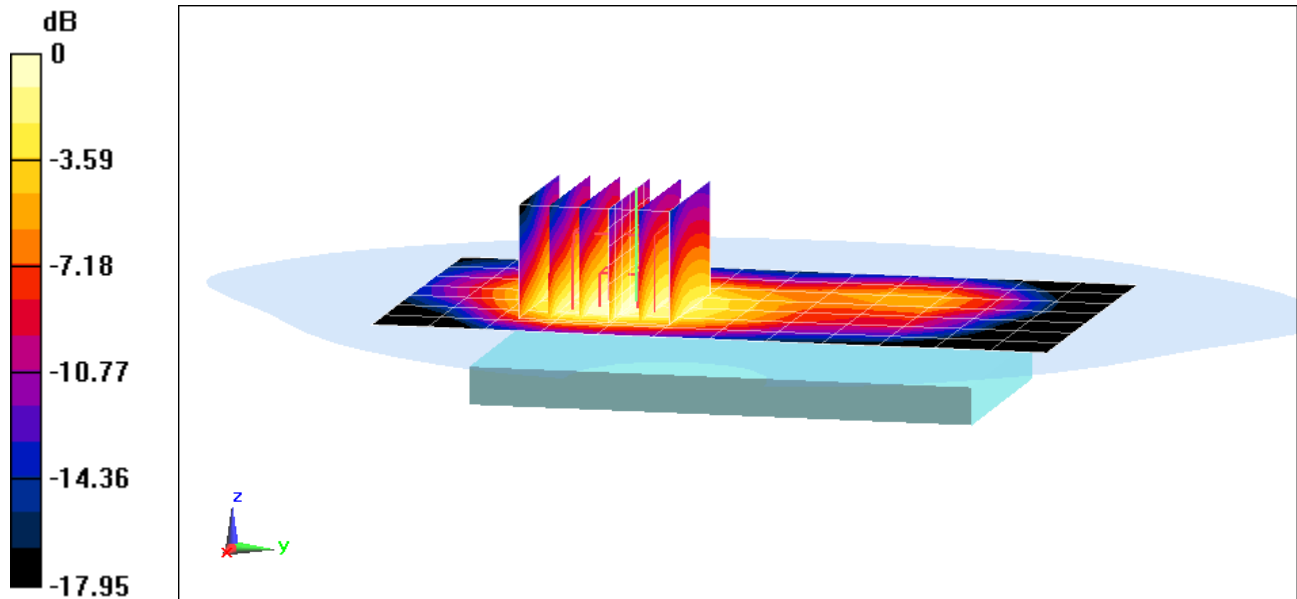

0 dB = 1.53 W/kg = 1.85 dBW/kg

PCTEST ENGINEERING LABORATORY, INC.

DUT: ZNFUS110; Type: Portable Handset; Serial: 01321

Communication System: UID 0, CDMA; Frequency: 1851.25 MHz; Duty Cycle: 1:1
Medium: 1900 Body Medium parameters used:
 $f = 1851.25 \text{ MHz}$; $\sigma = 1.515 \text{ S/m}$; $\epsilon_r = 51.969$; $\rho = 1000 \text{ kg/m}^3$
Phantom section: Flat Section; Space: 1.0 cm

Test Date: 12-23-2016; Ambient Temp: 22.9°C; Tissue Temp: 22.5°C

Probe: EX3DV4 - SN7409; ConvF(7.47, 7.47, 7.47); Calibrated: 5/17/2016;
Sensor-Surface: 1.4mm (Mechanical Surface Detection)
Electronics: DAE4 Sn859; Calibrated: 5/11/2016
Phantom: SAM Left; Type: QD000P40CC; Serial: TP: 1375
Measurement SW: DASY52, Version 52.8 (8); SEMCAD X Version 14.6.10 (7331)

Mode: PCS EVDO, Body SAR, Back side, Low.ch

Area Scan (8x13x1): Measurement grid: dx=15mm, dy=15mm
Zoom Scan (7x6x7)/Cube 0: Measurement grid: dx=8mm, dy=8mm, dz=5mm
Reference Value = 26.65 V/m; Power Drift = -0.01 dB
Peak SAR (extrapolated) = 1.71 W/kg
SAR(1 g) = 1.08 W/kg

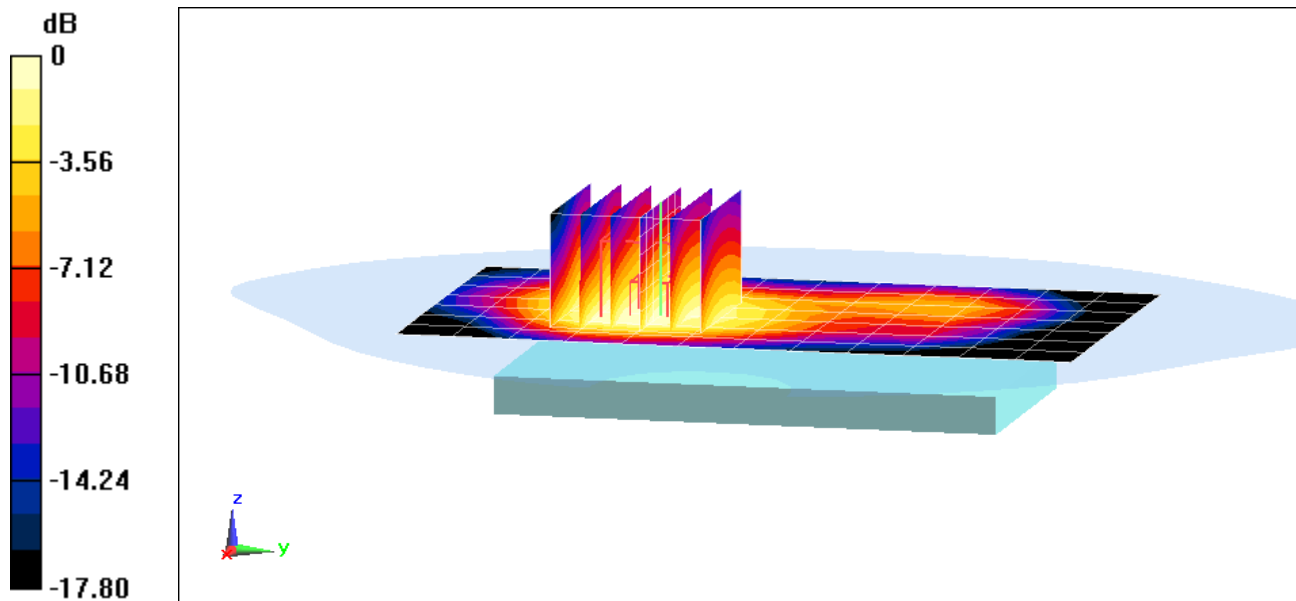

0 dB = 1.44 W/kg = 1.58 dBW/kg

PCTEST ENGINEERING LABORATORY, INC.

DUT: ZNFUS110; Type: Portable Handset; Serial: 01339

Communication System: UID 0, LTE Band 13; Frequency: 782 MHz; Duty Cycle: 1:1

Medium: 750 Body Medium parameters used (interpolated):

$f = 782 \text{ MHz}$; $\sigma = 0.994 \text{ S/m}$; $\epsilon_r = 53.883$; $\rho = 1000 \text{ kg/m}^3$

Phantom section: Flat Section; Space: 1.0 cm

Test Date: 12-22-2016; Ambient Temp: 21.1°C; Tissue Temp: 21.3°C

Probe: ES3DV3 - SN3318; ConvF(6.19, 6.19, 6.19); Calibrated: 2/19/2016;

Sensor-Surface: 3mm (Mechanical Surface Detection)

Electronics: DAE4 Sn665; Calibrated: 2/19/2016

Phantom: SAM with CRP v4.0; Type: QD000P40CD; Serial: TP:1800

Measurement SW: DASY52, Version 52.8 (8); SEMCAD X Version 14.6.10 (7331)

Mode: LTE Band 13, Body SAR, Back side, Mid.ch,

10 MHz Bandwidth, QPSK, 1 RB, 0 RB Offset

Area Scan (9x13x1): Measurement grid: dx=15mm, dy=15mm

Zoom Scan (5x5x7)/Cube 0: Measurement grid: dx=8mm, dy=8mm, dz=5mm

Reference Value = 24.47 V/m; Power Drift = 0.15 dB

Peak SAR (extrapolated) = 0.695 W/kg

SAR(1 g) = 0.562 W/kg

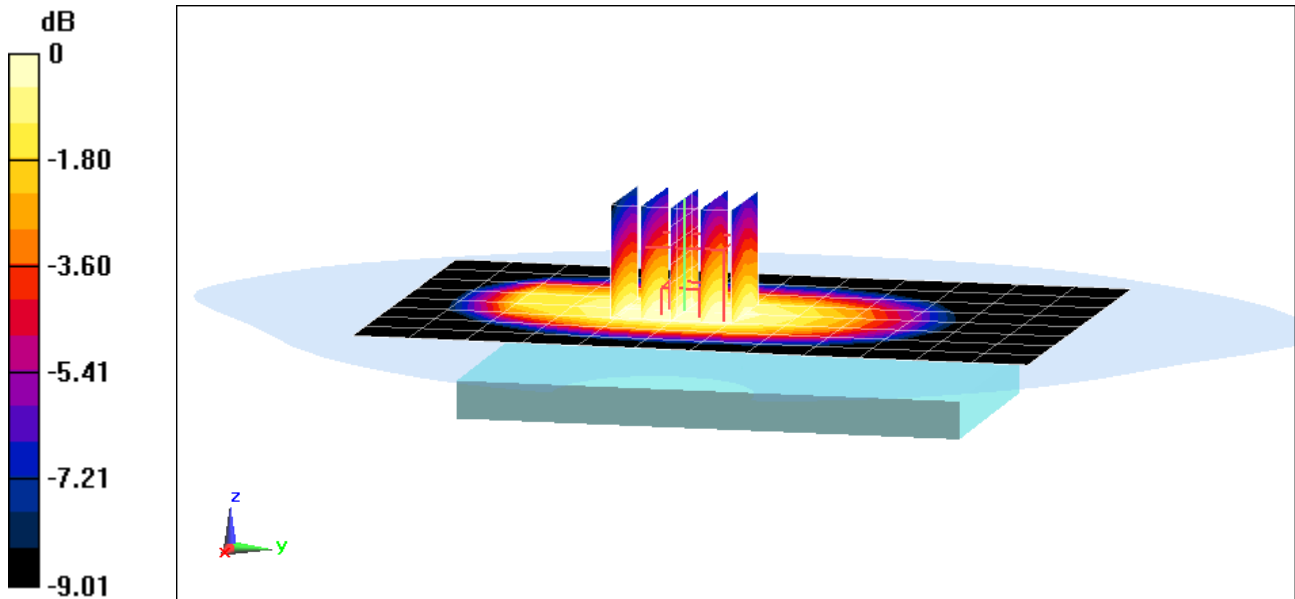

0 dB = 0.616 W/kg = -2.10 dBW/kg

PCTEST ENGINEERING LABORATORY, INC.

DUT: ZNFUS110; Type: Portable Handset; Serial: 01339

Communication System: UID 0, LTE Band 5; Frequency: 836.5 MHz; Duty Cycle: 1:1
Medium: 835 Body Medium parameters used (interpolated):
 $f = 836.5$ MHz; $\sigma = 0.999$ S/m; $\epsilon_r = 54.122$; $\rho = 1000$ kg/m³
Phantom section: Flat Section; Space: 1.0 cm

Test Date: 12-21-2016; Ambient Temp: 23.1°C; Tissue Temp: 22.2°C

Probe: ES3DV3 - SN3319; ConvF(6.04, 6.04, 6.04); Calibrated: 3/18/2016;
Sensor-Surface: 3mm (Mechanical Surface Detection)
Electronics: DAE4 Sn1368; Calibrated: 3/14/2016
Phantom: SAM with CRP (Left); Type: SAM; Serial: 1715
Measurement SW: DASY52, Version 52.8 (8); SEMCAD X Version 14.6.10 (7331)

**Mode: LTE Band 5 (Cell.), Body SAR, Back side, Mid.ch,
10 MHz Bandwidth, QPSK, 1 RB, 25 RB Offset**

Area Scan (8x13x1): Measurement grid: dx=15mm, dy=15mm
Zoom Scan (5x5x7)/Cube 0: Measurement grid: dx=8mm, dy=8mm, dz=5mm
Reference Value = 28.42 V/m; Power Drift = 0.08 dB
Peak SAR (extrapolated) = 1.01 W/kg
SAR(1 g) = 0.777 W/kg

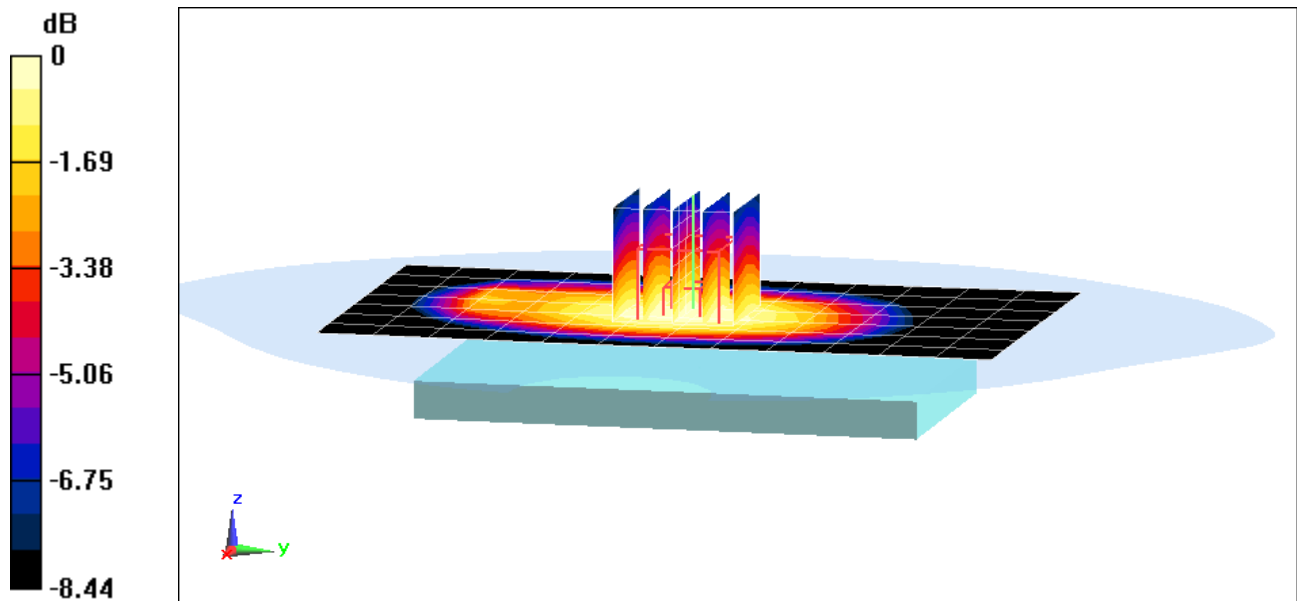

0 dB = 0.849 W/kg = -0.71 dBW/kg

PCTEST ENGINEERING LABORATORY, INC.

DUT: ZNFUS110; Type: Portable Handset; Serial: 01339

Communication System: UID 0, LTE Band 4 (AWS); Frequency: 1732.5 MHz; Duty Cycle: 1:1
Medium: 1750 Body Medium parameters used (interpolated):
 $f = 1732.5$ MHz; $\sigma = 1.491$ S/m; $\epsilon_r = 51.497$; $\rho = 1000$ kg/m³
Phantom section: Flat Section; Space: 1.0 cm

Test Date: 12-26-2016; Ambient Temp: 22.1°C; Tissue Temp: 21.1°C

Probe: ES3DV3 - SN3209; ConvF(4.99, 4.99, 4.99); Calibrated: 3/18/2016;
Sensor-Surface: 3mm (Mechanical Surface Detection)
Electronics: DAE4 Sn1364; Calibrated: 8/22/2016
Phantom: SAM Front; Type: QD000P40CD; Serial: TP:1758
Measurement SW: DASY52, Version 52.8 (8); SEMCAD X Version 14.6.10 (7331)

**Mode: LTE Band 4 (AWS), Body SAR, Back side, Mid.ch,
20 MHz Bandwidth, QPSK, 1 RB, 99 RB Offset**

Area Scan (9x15x1): Measurement grid: dx=15mm, dy=15mm
Zoom Scan (5x5x7)/Cube 0: Measurement grid: dx=8mm, dy=8mm, dz=5mm
Reference Value = 29.21 V/m; Power Drift = 0.04 dB
Peak SAR (extrapolated) = 1.83 W/kg
SAR(1 g) = 1.15 W/kg

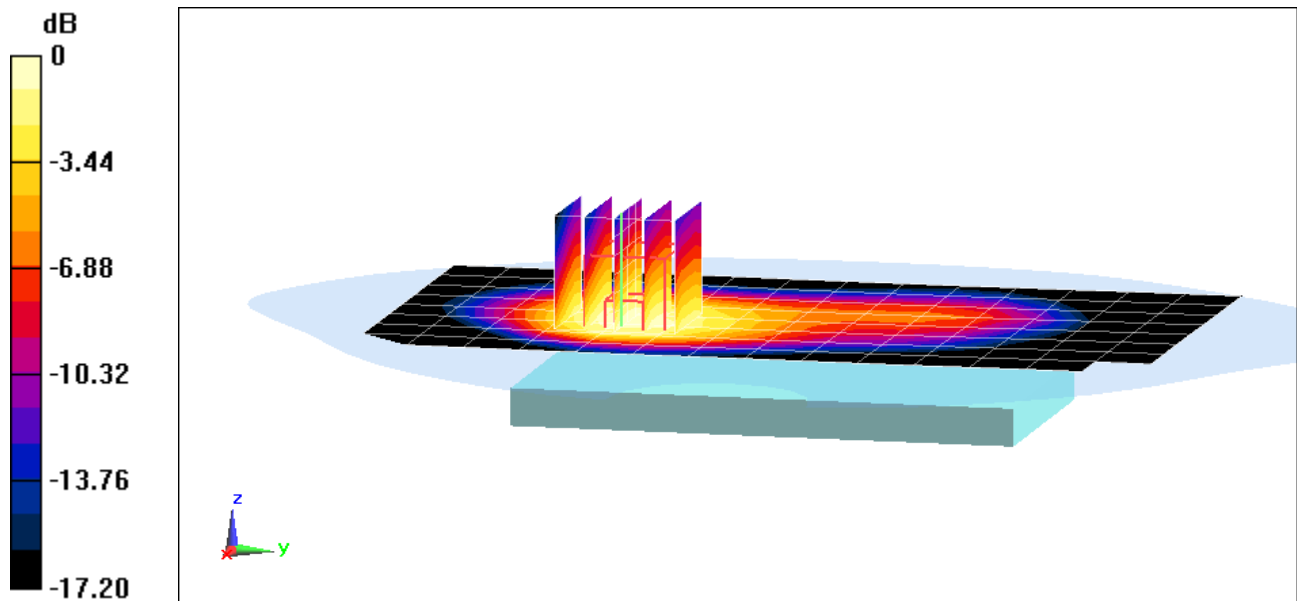

0 dB = 1.36 W/kg = 1.34 dBW/kg

PCTEST ENGINEERING LABORATORY, INC.

DUT: ZNFUS110; Type: Portable Handset; Serial: 01339

Communication System: UID 0, LTE Band 2 (PCS); Frequency: 1860 MHz; Duty Cycle: 1:1
Medium: 1900 Body Medium parameters used (interpolated):
 $f = 1860 \text{ MHz}$; $\sigma = 1.526 \text{ S/m}$; $\epsilon_r = 51.941$; $\rho = 1000 \text{ kg/m}^3$
Phantom section: Flat Section; Space: 1.0 cm

Test Date: 12-23-2016; Ambient Temp: 22.9°C; Tissue Temp: 22.5°C

Probe: EX3DV4 - SN7409; ConvF(7.47, 7.47, 7.47); Calibrated: 5/17/2016;
Sensor-Surface: 1.4mm (Mechanical Surface Detection)
Electronics: DAE4 Sn859; Calibrated: 5/11/2016
Phantom: SAM Left; Type: QD000P40CC; Serial: TP: 1375
Measurement SW: DASY52, Version 52.8 (8); SEMCAD X Version 14.6.10 (7331)

**Mode: LTE Band 2 (PCS), Body SAR, Back side, Low.ch,
20 MHz Bandwidth, QPSK, 1 RB, 50 RB Offset**

Area Scan (9x15x1): Measurement grid: dx=15mm, dy=15mm
Zoom Scan (5x5x7)/Cube 0: Measurement grid: dx=8mm, dy=8mm, dz=5mm
Reference Value = 26.79 V/m; Power Drift = 0.09 dB
Peak SAR (extrapolated) = 1.75 W/kg
SAR(1 g) = 1.07 W/kg

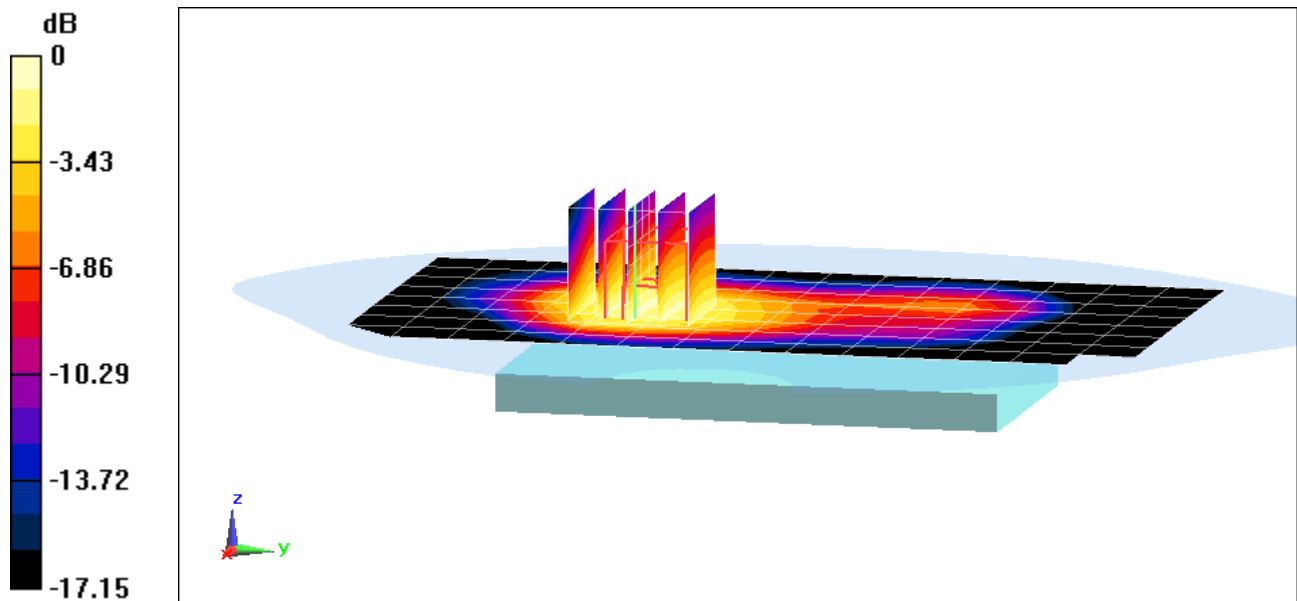

0 dB = 1.48 W/kg = 1.70 dBW/kg

PCTEST ENGINEERING LABORATORY, INC.

DUT: ZNFUS110; Type: Portable Handset; Serial: 01347

Communication System: UID 0, IEEE 802.11b; Frequency: 2437 MHz; Duty Cycle: 1:1
Medium: 2450 Body Medium parameters used (interpolated):
 $f = 2437 \text{ MHz}$; $\sigma = 2.016 \text{ S/m}$; $\epsilon_r = 52.048$; $\rho = 1000 \text{ kg/m}^3$
Phantom section: Flat Section; Space: 1.0 cm

Test Date: 12-23-2016; Ambient Temp: 23.8°C; Tissue Temp: 22.4°C

Probe: ES3DV3 - SN3287; ConvF(4.35, 4.35, 4.35); Calibrated: 9/19/2016;
Sensor-Surface: 3mm (Mechanical Surface Detection)
Electronics: DAE4 Sn1408; Calibrated: 9/14/2016
Phantom: SAM Front; Type: SAM; Serial: 1686
Measurement SW: DASY52, Version 52.8 (8); SEMCAD X Version 14.6.10 (7331)

Mode: IEEE 802.11b, 22 MHz Bandwidth, Body SAR, Ch 6, 1 Mbps, Back Side

Area Scan (10x16x1): Measurement grid: dx=12mm, dy=12mm
Zoom Scan (7x7x7)/Cube 0: Measurement grid: dx=5mm, dy=5mm, dz=5mm
Reference Value = 9.717 V/m; Power Drift = 0.04 dB
Peak SAR (extrapolated) = 0.341 W/kg
SAR(1 g) = 0.170 W/kg

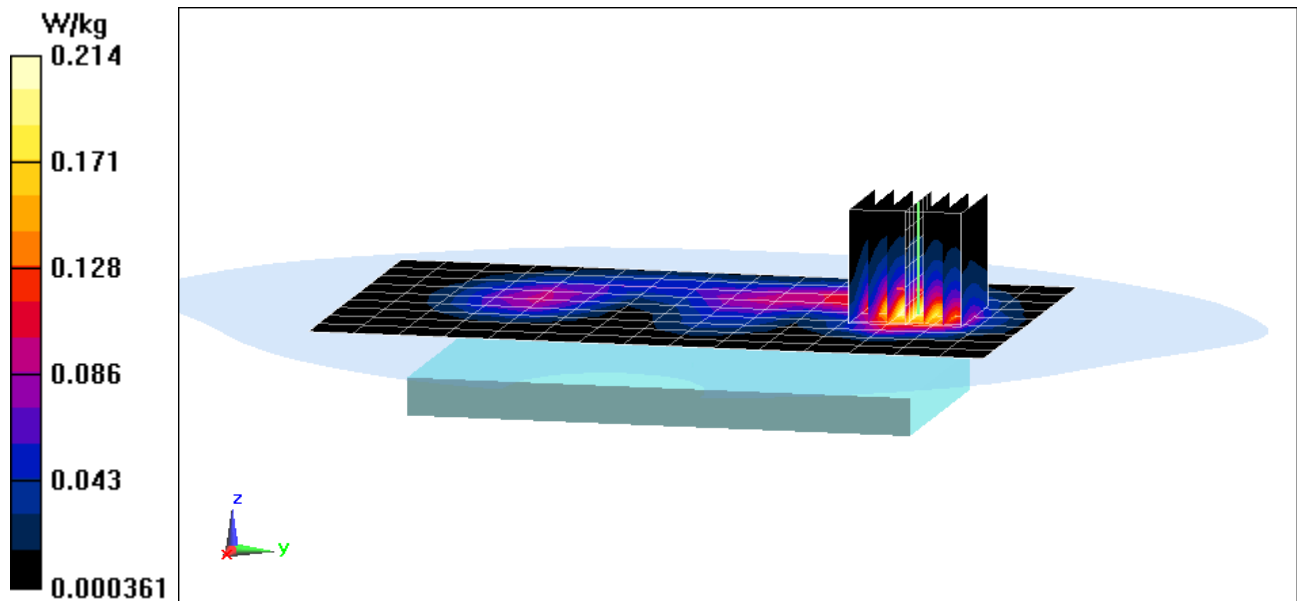

APPENDIX B: SYSTEM VERIFICATION

PCTEST ENGINEERING LABORATORY, INC.

DUT: Dipole 750 MHz; Type: D750V3; Serial: 1054

Communication System: UID 0, CW; Frequency: 750 MHz; Duty Cycle: 1:1

Medium: 750 Head Medium parameters used (interpolated):

$f = 750 \text{ MHz}$; $\sigma = 0.904 \text{ S/m}$; $\epsilon_r = 42.271$; $\rho = 1000 \text{ kg/m}^3$

Phantom section: Flat Section; Space: 1.5 cm

Test Date: 12-22-2016; Ambient Temp: 23.7°C; Tissue Temp: 21.9°C

Probe: ES3DV3 - SN3287; ConvF(6.96, 6.96, 6.96); Calibrated: 9/19/2016;

Sensor-Surface: 3mm (Mechanical Surface Detection)

Electronics: DAE4 Sn1408; Calibrated: 9/14/2016

Phantom: SAM Front; Type: SAM; Serial: 1686

Measurement SW: DASY52, Version 52.8 (8); SEMCAD X Version 14.6.10 (7331)

750 MHz System Verification at 23.0 dBm (200 mW)

Area Scan (7x15x1): Measurement grid: dx=15mm, dy=15mm

Zoom Scan (5x5x7)/Cube 0: Measurement grid: dx=8mm, dy=8mm, dz=5mm

Peak SAR (extrapolated) = 2.29 W/kg

SAR(1 g) = 1.54 W/kg

Deviation(1 g) = -6.33%

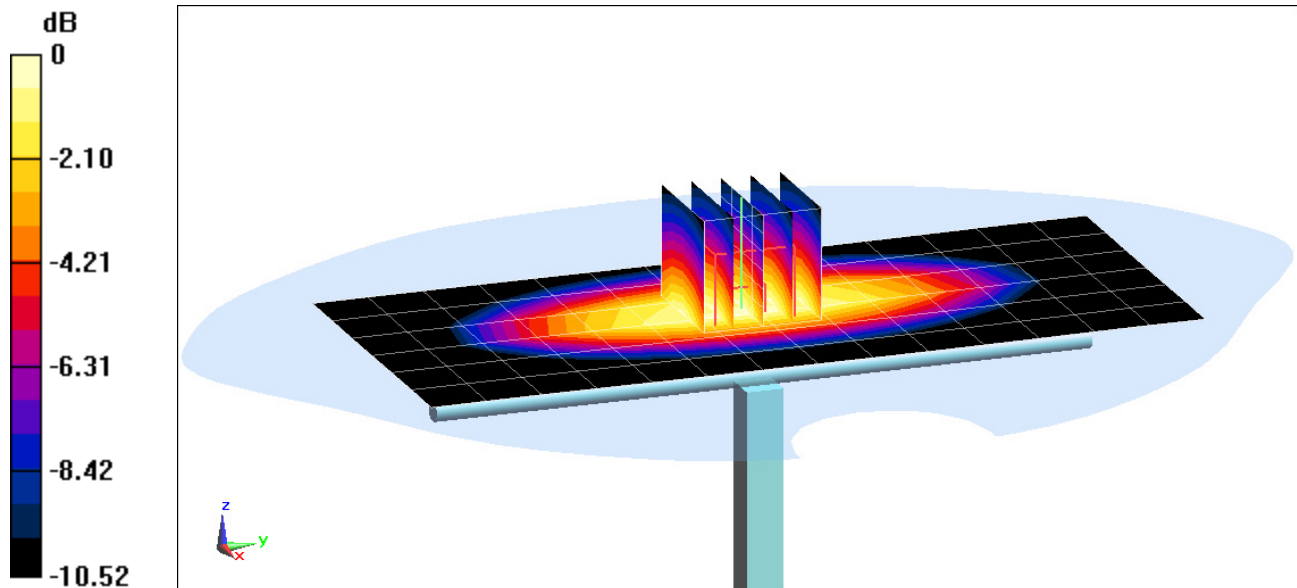

0 dB = 1.80 W/kg = 2.55 dBW/kg

PCTEST ENGINEERING LABORATORY, INC.

DUT: Dipole 835 MHz; Type: D835V2; Serial: 4d047

Communication System: UID 0, CW; Frequency: 835 MHz; Duty Cycle: 1:1

Medium: 835 Head Medium parameters used:

$f = 835 \text{ MHz}$; $\sigma = 0.904 \text{ S/m}$; $\epsilon_r = 41.364$; $\rho = 1000 \text{ kg/m}^3$

Phantom section: Flat Section; Space: 1.5 cm

Test Date: 12-22-2016; Ambient Temp: 22.7°C; Tissue Temp: 21.5°C

Probe: EX3DV4 - SN7406; ConvF(9.83, 9.83, 9.83); Calibrated: 4/19/2016;

Sensor-Surface: 1.4mm (Mechanical Surface Detection)

Electronics: DAE4 Sn1407; Calibrated: 4/14/2016

Phantom: SAM 5.0 front; Type: QD000P40CD; Serial: TP:-1648

Measurement SW: DASY52, Version 52.8 (8); SEMCAD X Version 14.6.10 (7331)

835 MHz System Verification at 23.0 dBm (200 mW)

Area Scan (7x14x1): Measurement grid: dx=15mm, dy=15mm

Zoom Scan (5x5x7)/Cube 0: Measurement grid: dx=8mm, dy=8mm, dz=5mm

Peak SAR (extrapolated) = 2.74 W/kg

SAR(1 g) = 1.86 W/kg

Deviation(1 g) = 1.86%

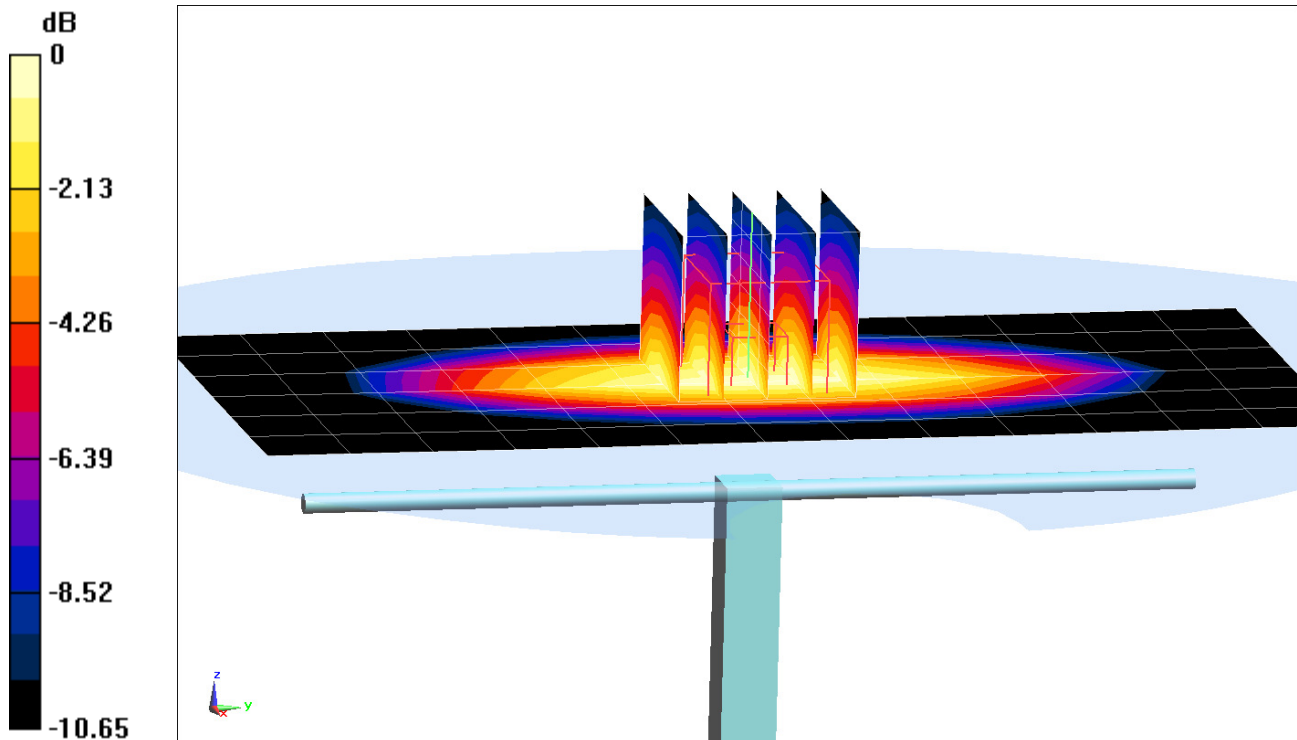

0 dB = 2.46 W/kg = 3.91 dBW/kg

PCTEST ENGINEERING LABORATORY, INC.

DUT: Dipole 1750 MHz; Type: D1750V2; Serial: 1148

Communication System: UID 0, CW; Frequency: 1750 MHz; Duty Cycle: 1:1

Medium: 1750 Head Medium parameters used:

$f = 1750$ MHz; $\sigma = 1.379$ S/m; $\epsilon_r = 40.732$; $\rho = 1000$ kg/m³

Phantom section: Flat Section; Space: 1.0 cm

Test Date: 12-24-2016; Ambient Temp: 23.0°C; Tissue Temp: 21.6°C

Probe: EX3DV4 - SN7406; ConvF(8.85, 8.85, 8.85); Calibrated: 4/19/2016;

Sensor-Surface: 1.4mm (Mechanical Surface Detection)

Electronics: DAE4 Sn1407; Calibrated: 4/14/2016

Phantom: SAM 5.0 front; Type: QD000P40CD; Serial: TP:-1648

Measurement SW: DASY52, Version 52.8 (8); SEMCAD X Version 14.6.10 (7331)

1750 MHz System Verification at 20.0 dBm (100 mW)

Area Scan (7x9x1): Measurement grid: dx=15mm, dy=15mm

Zoom Scan (5x5x7)/Cube 0: Measurement grid: dx=8mm, dy=8mm, dz=5mm

Peak SAR (extrapolated) = 5.94 W/kg

SAR(1 g) = 3.35 W/kg

Deviation(1 g) = -7.46%

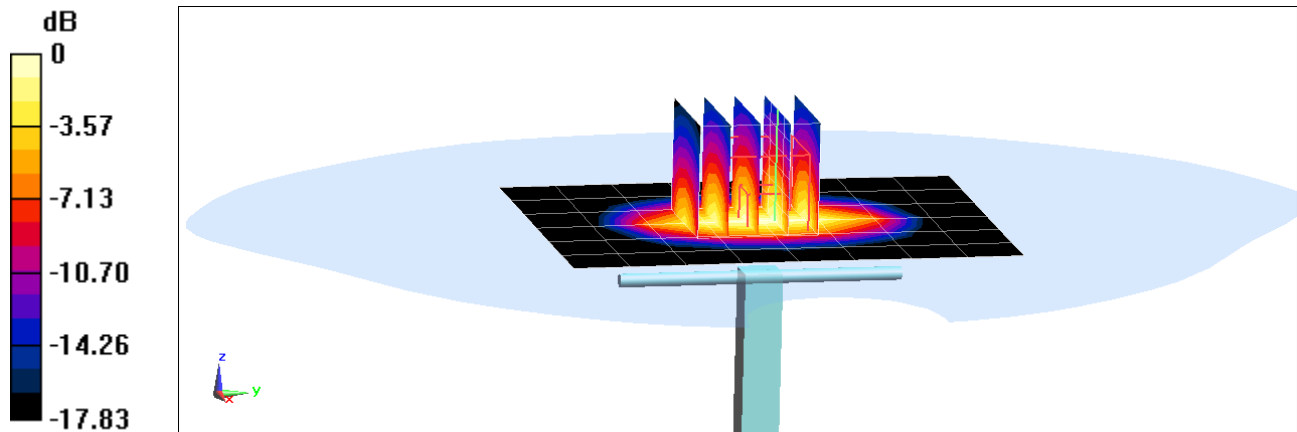

0 dB = 5.01 W/kg = 7.00 dBW/kg

PCTEST ENGINEERING LABORATORY, INC.

DUT: Dipole 1900 MHz; Type: D1900V2; Serial: 5d149

Communication System: UID 0, CW; Frequency: 1900 MHz; Duty Cycle: 1:1

Medium: 1900 Head Medium parameters used (interpolated):

$f = 1900 \text{ MHz}$; $\sigma = 1.444 \text{ S/m}$; $\epsilon_r = 39.039$; $\rho = 1000 \text{ kg/m}^3$

Phantom section: Flat Section; Space: 1.0 cm

Test Date: 12-26-2016; Ambient Temp: 23.3°C; Tissue Temp: 22.0°C

Probe: ES3DV3 - SN3287; ConvF(5.27, 5.27, 5.27); Calibrated: 9/19/2016;

Sensor-Surface: 3mm (Mechanical Surface Detection)

Electronics: DAE4 Sn1408; Calibrated: 9/14/2016

Phantom: SAM Front; Type: SAM; Serial: 1686

Measurement SW: DASY52, Version 52.8 (8); SEMCAD X Version 14.6.10 (7331)

1900 MHz System Verification at 20.0 dBm (100 mW)

Area Scan (7x10x1): Measurement grid: dx=15mm, dy=15mm

Zoom Scan (5x5x7)/Cube 0: Measurement grid: dx=8mm, dy=8mm, dz=5mm

Peak SAR (extrapolated) = 7.09 W/kg

SAR(1 g) = 3.86 W/kg

Deviation(1 g) = -3.74%

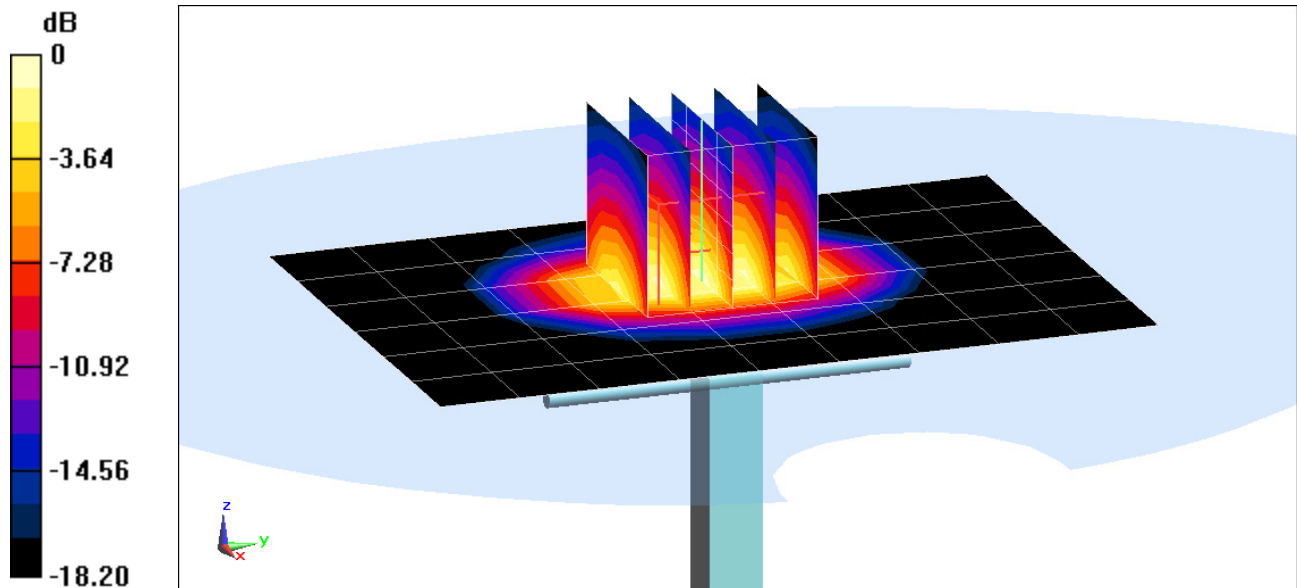

0 dB = 4.91 W/kg = 6.91 dBW/kg

PCTEST ENGINEERING LABORATORY, INC.

DUT: Dipole 2450 MHz; Type: D2450V2; Serial: 981

Communication System: UID 0, CW; Frequency: 2450 MHz; Duty Cycle: 1:1

Medium: 2450 Head Medium parameters used:

$f = 2450 \text{ MHz}$; $\sigma = 1.885 \text{ S/m}$; $\epsilon_r = 38.127$; $\rho = 1000 \text{ kg/m}^3$

Phantom section: Flat Section; Space: 1.0 cm

Test Date: 12-27-2016; Ambient Temp: 21.0°C; Tissue Temp: 22.5°C

Probe: EX3DV4 - SN7406; ConvF(7.29, 7.29, 7.29); Calibrated: 4/19/2016;

Sensor-Surface: 1.4mm (Mechanical Surface Detection)

Electronics: DAE4 Sn1407; Calibrated: 4/14/2016

Phantom: SAM 5.0 front; Type: QD000P40CD; Serial: TP:-1648

Measurement SW: DASY52, Version 52.8 (8); SEMCAD X Version 14.6.10 (7331)

2450 MHz System Verification at 20.0 dBm (100 mW)

Area Scan (8x9x1): Measurement grid: dx=12mm, dy=12mm

Zoom Scan (7x7x7)/Cube 0: Measurement grid: dx=5mm, dy=5mm, dz=5mm

Peak SAR (extrapolated) = 11.9 W/kg

SAR(1 g) = 5.67 W/kg

Deviation(1 g) = 7.39%

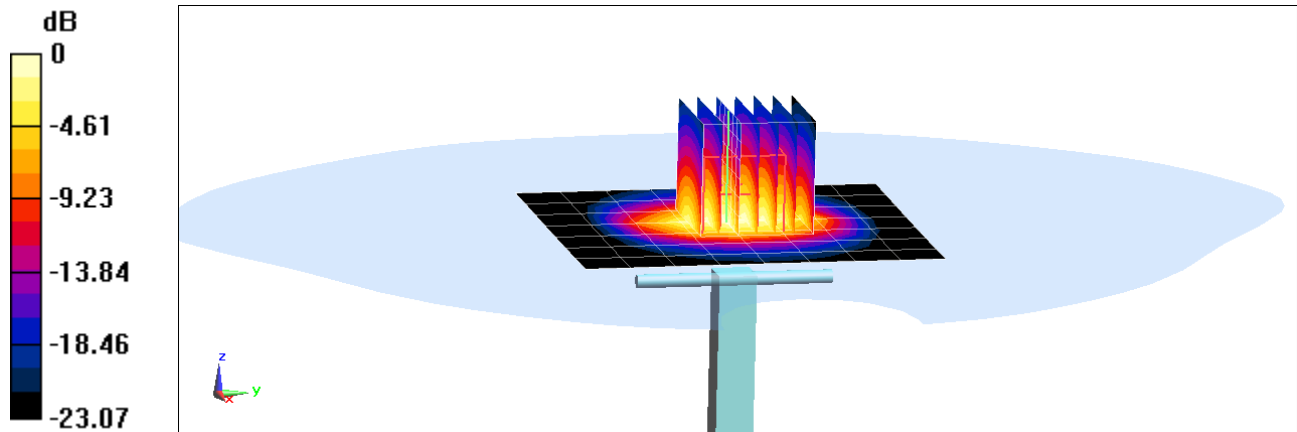

0 dB = 9.47 W/kg = 9.76 dBW/kg

PCTEST ENGINEERING LABORATORY, INC.

DUT: Dipole 750 MHz; Type: D750V3; Serial: 1054

Communication System: UID 0, CW; Frequency: 750 MHz; Duty Cycle: 1:1

Medium: 750 Body Medium parameters used (interpolated):

$f = 750 \text{ MHz}$; $\sigma = 0.963 \text{ S/m}$; $\epsilon_r = 54.221$; $\rho = 1000 \text{ kg/m}^3$

Phantom section: Flat Section; Space: 1.5 cm

Test Date: 12-22-2016; Ambient Temp: 21.1°C; Tissue Temp: 21.3°C

Probe: ES3DV3 - SN3318; ConvF(6.19, 6.19, 6.19); Calibrated: 2/19/2016;

Sensor-Surface: 3mm (Mechanical Surface Detection)

Electronics: DAE4 Sn665; Calibrated: 2/19/2016

Phantom: SAM with CRP v4.0; Type: QD000P40CD; Serial: TP:1800

Measurement SW: DASY52, Version 52.8 (8); SEMCAD X Version 14.6.10 (7331)

750 MHz System Verification at 23.0 dBm (200 mW)

Area Scan (7x15x1): Measurement grid: dx=15mm, dy=15mm

Zoom Scan (5x5x7)/Cube 0: Measurement grid: dx=8mm, dy=8mm, dz=5mm

Peak SAR (extrapolated) = 2.46 W/kg

SAR(1 g) = 1.71 W/kg

Deviation(1 g) = -0.12%

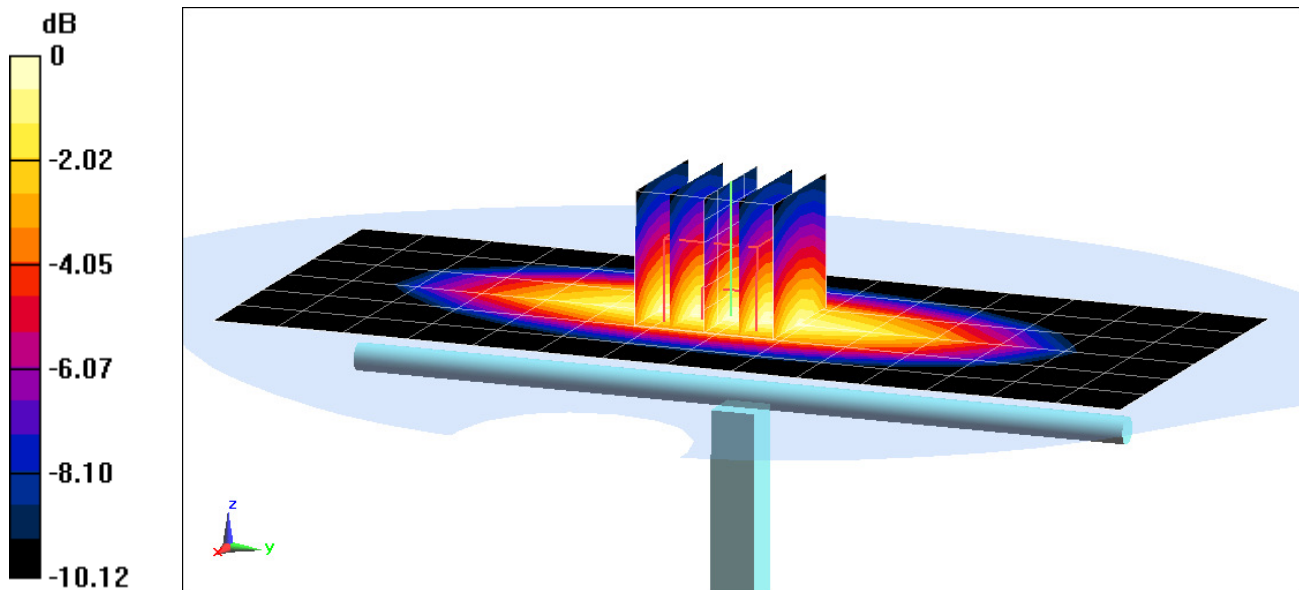

0 dB = 1.98 W/kg = 2.97 dBW/kg

PCTEST ENGINEERING LABORATORY, INC.

DUT: Dipole 835 MHz; Type: D835V2; Serial: 4d047

Communication System: UID 0, CW; Frequency: 835 MHz; Duty Cycle: 1:1

Medium: 835 Body; Medium parameters used:

$f = 835 \text{ MHz}$; $\sigma = 1.012 \text{ S/m}$; $\epsilon_r = 54.127$; $\rho = 1000 \text{ kg/m}^3$

Phantom section: Flat Section; Space: 1.5 cm

Test Date: 01-05-2017; Ambient Temp: 23.2°C; Tissue Temp: 22.0°C

Probe: ES3DV3 - SN3319; ConvF(6.04, 6.04, 6.04); Calibrated: 3/18/2016;

Sensor-Surface: 3mm (Mechanical Surface Detection)

Electronics: DAE4 Sn1368; Calibrated: 3/14/2016

Phantom: SAM with CRP (Left); Type: SAM; Serial: 1715

Measurement SW: DASY52, Version 52.8 (8); SEMCAD X Version 14.6.10 (7331)

835 MHz System Verification at 23.0 dBm (200 mW)

Area Scan (7x14x1): Measurement grid: dx=15mm, dy=15mm

Zoom Scan (5x5x7)/Cube 0: Measurement grid: dx=8mm, dy=8mm, dz=5mm

Peak SAR (extrapolated) = 2.90 W/kg

SAR(1 g) = 1.97 W/kg

Deviation(1 g) = 2.93%

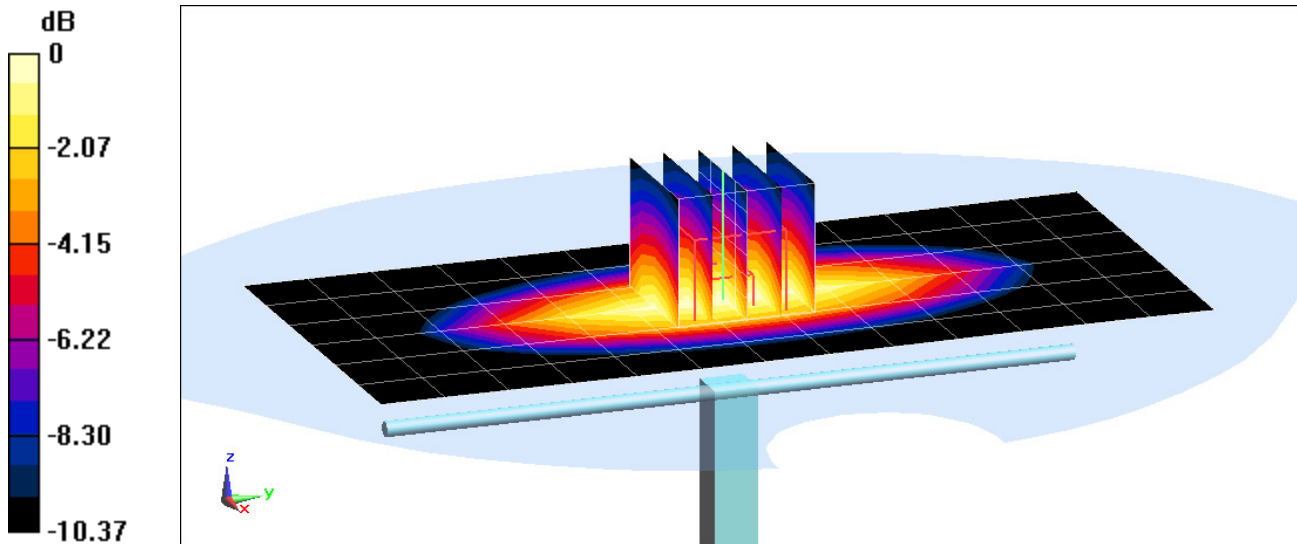

0 dB = 2.30 W/kg = 3.62 dBW/kg

PCTEST ENGINEERING LABORATORY, INC.

DUT: Dipole 1750 MHz; Type: D1750V2; Serial: 1148

Communication System: UID 0, CW; Frequency: 1750 MHz; Duty Cycle: 1:1

Medium: 1750 Body Medium parameters used:

$f = 1750$ MHz; $\sigma = 1.509$ S/m; $\epsilon_r = 51.447$; $\rho = 1000$ kg/m³

Phantom section: Flat Section; Space: 1.0 cm

Test Date: 12-26-2016; Ambient Temp: 22.1°C; Tissue Temp: 21.1°C

Probe: ES3DV3 - SN3209; ConvF(4.99, 4.99, 4.99); Calibrated: 3/18/2016;

Sensor-Surface: 3mm (Mechanical Surface Detection)

Electronics: DAE4 Sn1364; Calibrated: 8/22/2016

Phantom: SAM Front; Type: QD000P40CD; Serial: TP:1758

Measurement SW: DASY52, Version 52.8 (8); SEMCAD X Version 14.6.10 (7331)

1750 MHz System Verification at 20.0 dBm (100 mW)

Area Scan (7x9x1): Measurement grid: dx=15mm, dy=15mm

Zoom Scan (5x5x7)/Cube 0: Measurement grid: dx=8mm, dy=8mm, dz=5mm

Peak SAR (extrapolated) = 6.31 W/kg

SAR(1 g) = 3.61 W/kg

Deviation(1 g) = -2.70%

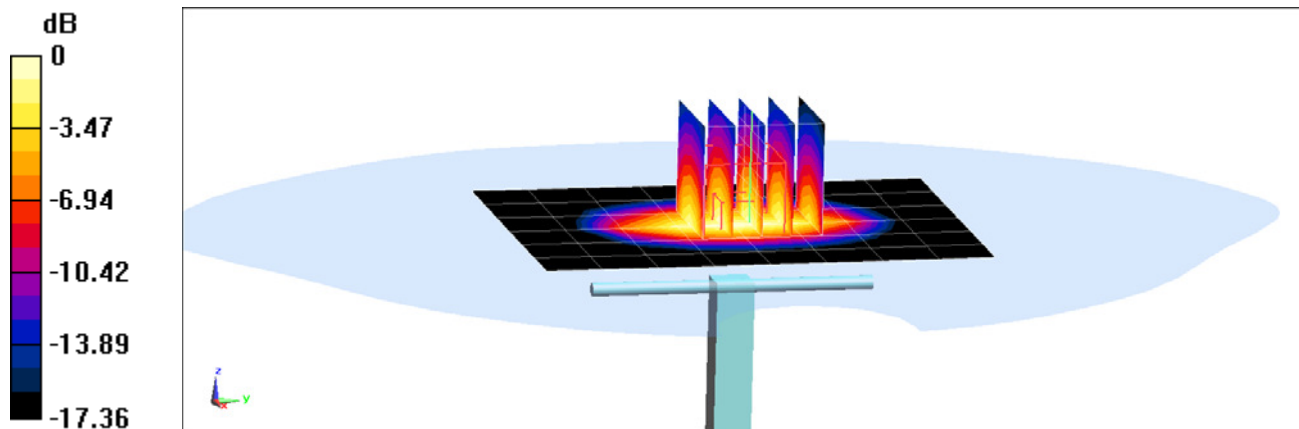

0 dB = 4.46 W/kg = 6.49 dBW/kg

PCTEST ENGINEERING LABORATORY, INC.

DUT: Dipole 1900 MHz; Type: D1900V2; Serial: 5d149

Communication System: UID 0, CW; Frequency: 1900 MHz; Duty Cycle: 1:1
Medium: 1900 Body Medium parameters used (interpolated):
 $f = 1900 \text{ MHz}$; $\sigma = 1.546 \text{ S/m}$; $\epsilon_r = 52.305$; $\rho = 1000 \text{ kg/m}^3$
Phantom section: Flat Section; Space: 1.0 cm

Test Date: 01-04-2017; Ambient Temp: 24.0°C; Tissue Temp: 23.5°C

Probe: EX3DV4 - SN7409; ConvF(7.47, 7.47, 7.47); Calibrated: 5/17/2016;
Sensor-Surface: 1.4mm (Mechanical Surface Detection)
Electronics: DAE4 Sn859; Calibrated: 5/11/2016
Phantom: SAM Left; Type: QD000P40CC; Serial: TP: 1375
Measurement SW: DASY52, Version 52.8 (8); SEMCAD X Version 14.6.10 (7331)

1900 MHz System Verification at 20.0 dBm (100 mW)

Area Scan (7x11x1): Measurement grid: dx=15mm, dy=15mm
Zoom Scan (5x5x7)/Cube 0: Measurement grid: dx=8mm, dy=8mm, dz=5mm
Peak SAR (extrapolated) = 7.77 W/kg
SAR(1 g) = 4.22 W/kg
Deviation(1 g) = 5.76%

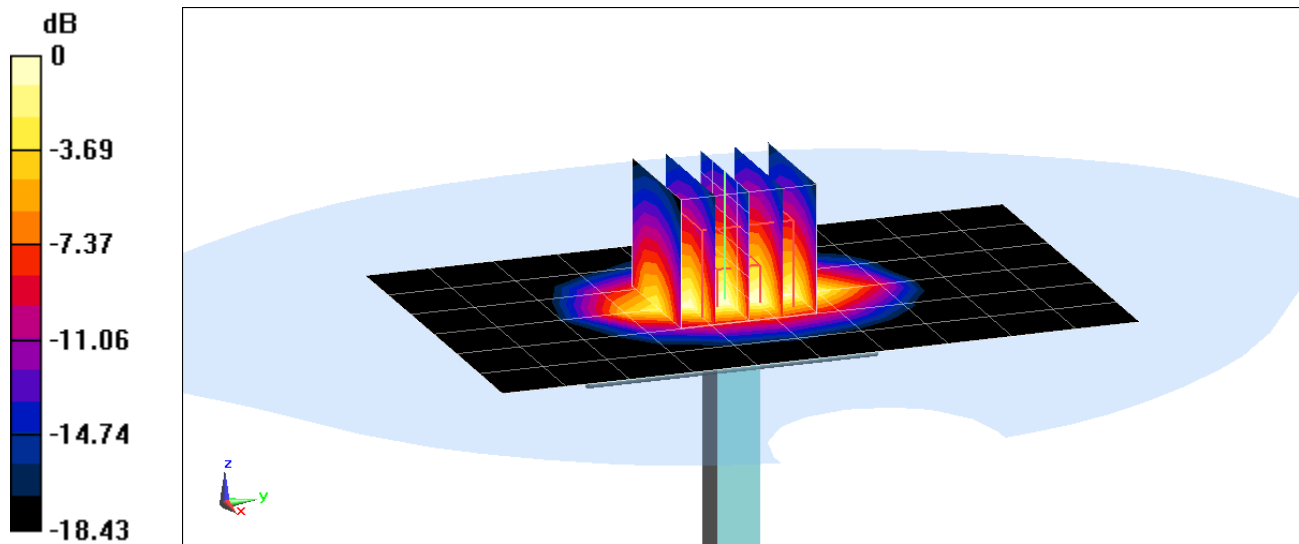

0 dB = 6.54 W/kg = 8.16 dBW/kg

PCTEST ENGINEERING LABORATORY, INC.

DUT: Dipole 2450 MHz; Type: D2450V2; Serial: 981

Communication System: UID 0, CW; Frequency: 2450 MHz; Duty Cycle: 1:1

Medium: 2450 Body Medium parameters used:

$f = 2450$ MHz; $\sigma = 2.032$ S/m; $\epsilon_r = 51.985$; $\rho = 1000$ kg/m³

Phantom section: Flat Section; Space: 1.0 cm

Test Date: 12-23-2016; Ambient Temp: 23.8°C; Tissue Temp: 22.4°C

Probe: ES3DV3 - SN3287; ConvF(4.35, 4.35, 4.35); Calibrated: 9/19/2016;

Sensor-Surface: 3mm (Mechanical Surface Detection)

Electronics: DAE4 Sn1408; Calibrated: 9/14/2016

Phantom: SAM Front; Type: SAM; Serial: 1686

Measurement SW: DASY52, Version 52.8 (8); SEMCAD X Version 14.6.10 (7331)

2450 MHz System Verification at 20.0 dBm (100 mW)

Area Scan (8x9x1): Measurement grid: dx=12mm, dy=12mm

Zoom Scan (7x7x7)/Cube 0: Measurement grid: dx=5mm, dy=5mm, dz=5mm

Peak SAR (extrapolated) = 11.3 W/kg

SAR(1 g) = 5.28 W/kg

Deviation(1 g) = 3.94%

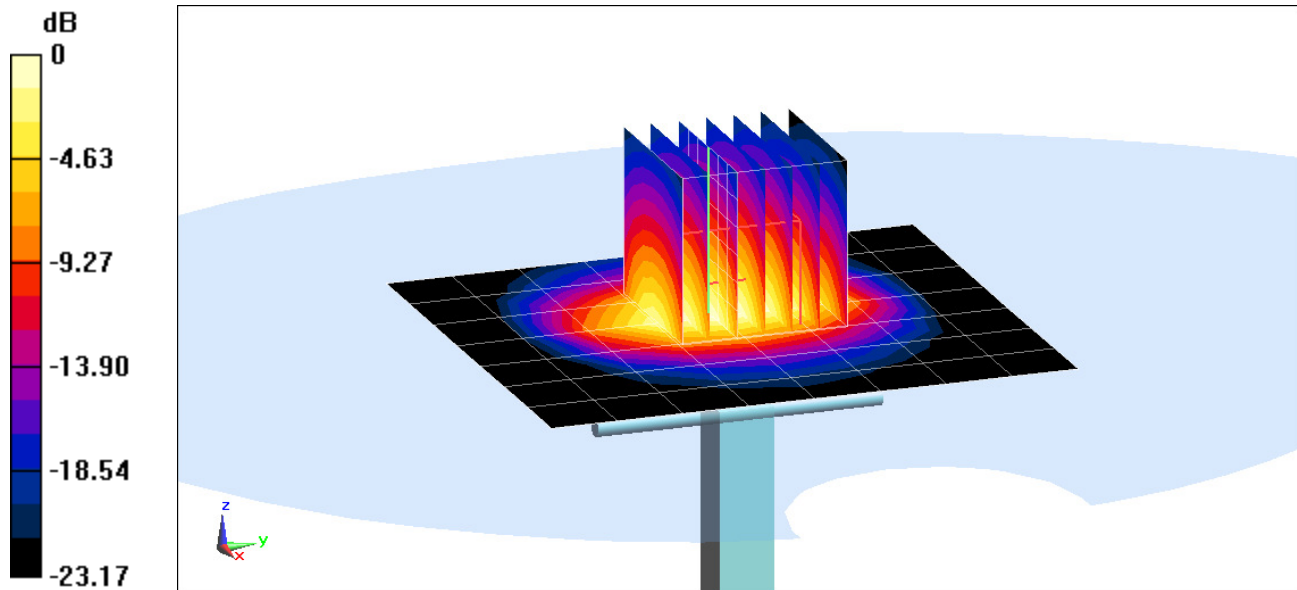

0 dB = 6.96 W/kg = 8.43 dBW/kg

APPENDIX C: PROBE CALIBRATION



Accredited by the Swiss Accreditation Service (SAS)
The Swiss Accreditation Service is one of the signatories to the EA
Multilateral Agreement for the recognition of calibration certificates

Accreditation No.: **SCS 0108**

Client **PC Test**

Certificate No: **D750V3-1054_Mar16**

CALIBRATION CERTIFICATE

Object **D750V3 - SN:1054**

Calibration procedure(s) **QA CAL-05.v9
Calibration procedure for dipole validation kits above 700 MHz**

Calibration date: **March 16, 2016**

*BN
03/30/2016*

This calibration certificate documents the traceability to national standards, which realize the physical units of measurements (SI).
The measurements and the uncertainties with confidence probability are given on the following pages and are part of the certificate.

All calibrations have been conducted in the closed laboratory facility: environment temperature (22 ± 3)°C and humidity < 70%.

Calibration Equipment used (M&TE critical for calibration)

Primary Standards	ID #	Cal Date (Certificate No.)	Scheduled Calibration
Power meter EPM-442A	GB37480704	07-Oct-15 (No. 217-02222)	Oct-16
Power sensor HP 8481A	US37292783	07-Oct-15 (No. 217-02222)	Oct-16
Power sensor HP 8481A	MY41092317	07-Oct-15 (No. 217-02223)	Oct-16
Reference 20 dB Attenuator	SN: 5058 (20k)	01-Apr-15 (No. 217-02131)	Mar-16
Type-N mismatch combination	SN: 5047.2 / 06327	01-Apr-15 (No. 217-02134)	Mar-16
Reference Probe EX3DV4	SN: 7349	31-Dec-15 (No. EX3-7349_Dec15)	Dec-16
DAE4	SN: 601	30-Dec-15 (No. DAE4-601_Dec15)	Dec-16

Secondary Standards	ID #	Check Date (in house)	Scheduled Check
RF generator R&S SMT-06	100972	15-Jun-15 (in house check Jun-15)	In house check: Jun-18
Network Analyzer HP 8753E	US37390585 S4206	18-Oct-01 (in house check Oct-15)	In house check: Oct-16

Calibrated by: **Jeton Kastrati** (Name), **Laboratory Technician** (Function), *[Signature]* (Signature)

Approved by: **Katja Pokovic** (Name), **Technical Manager** (Function), *[Signature]* (Signature)

Issued: March 16, 2016

This calibration certificate shall not be reproduced except in full without written approval of the laboratory.



Accredited by the Swiss Accreditation Service (SAS)
The Swiss Accreditation Service is one of the signatories to the EA
Multilateral Agreement for the recognition of calibration certificates

Accreditation No.: **SCS 0108**

Glossary:

TSL	tissue simulating liquid
ConvF	sensitivity in TSL / NORM x,y,z
N/A	not applicable or not measured

Calibration is Performed According to the Following Standards:

- IEEE Std 1528-2013, "IEEE Recommended Practice for Determining the Peak Spatial-Averaged Specific Absorption Rate (SAR) in the Human Head from Wireless Communications Devices: Measurement Techniques", June 2013
- IEC 62209-1, "Procedure to measure the Specific Absorption Rate (SAR) for hand-held devices used in close proximity to the ear (frequency range of 300 MHz to 3 GHz)", February 2005
- IEC 62209-2, "Procedure to determine the Specific Absorption Rate (SAR) for wireless communication devices used in close proximity to the human body (frequency range of 30 MHz to 6 GHz)", March 2010
- KDB 865664, "SAR Measurement Requirements for 100 MHz to 6 GHz"

Additional Documentation:

- DASY4/5 System Handbook

Methods Applied and Interpretation of Parameters:

- Measurement Conditions:** Further details are available from the Validation Report at the end of the certificate. All figures stated in the certificate are valid at the frequency indicated.
- Antenna Parameters with TSL:** The dipole is mounted with the spacer to position its feed point exactly below the center marking of the flat phantom section, with the arms oriented parallel to the body axis.
- Feed Point Impedance and Return Loss:** These parameters are measured with the dipole positioned under the liquid filled phantom. The impedance stated is transformed from the measurement at the SMA connector to the feed point. The Return Loss ensures low reflected power. No uncertainty required.
- Electrical Delay:** One-way delay between the SMA connector and the antenna feed point. No uncertainty required.
- SAR measured:** SAR measured at the stated antenna input power.
- SAR normalized:** SAR as measured, normalized to an input power of 1 W at the antenna connector.
- SAR for nominal TSL parameters:** The measured TSL parameters are used to calculate the nominal SAR result.

The reported uncertainty of measurement is stated as the standard uncertainty of measurement multiplied by the coverage factor $k=2$, which for a normal distribution corresponds to a coverage probability of approximately 95%.

Measurement Conditions

DASY system configuration, as far as not given on page 1.

DASY Version	DASY5	V52.8.8
Extrapolation	Advanced Extrapolation	
Phantom	Modular Flat Phantom	
Distance Dipole Center - TSL	15 mm	with Spacer
Zoom Scan Resolution	dx, dy, dz = 5 mm	
Frequency	750 MHz ± 1 MHz	

Head TSL parameters

The following parameters and calculations were applied.

	Temperature	Permittivity	Conductivity
Nominal Head TSL parameters	22.0 °C	41.9	0.89 mho/m
Measured Head TSL parameters	(22.0 ± 0.2) °C	41.9 ± 6 %	0.91 mho/m ± 6 %
Head TSL temperature change during test	< 0.5 °C	----	----

SAR result with Head TSL

SAR averaged over 1 cm³ (1 g) of Head TSL	Condition	
SAR measured	250 mW input power	2.09 W/kg
SAR for nominal Head TSL parameters	normalized to 1W	8.22 W/kg ± 17.0 % (k=2)

SAR averaged over 10 cm³ (10 g) of Head TSL	condition	
SAR measured	250 mW input power	1.37 W/kg
SAR for nominal Head TSL parameters	normalized to 1W	5.41 W/kg ± 16.5 % (k=2)

Body TSL parameters

The following parameters and calculations were applied.

	Temperature	Permittivity	Conductivity
Nominal Body TSL parameters	22.0 °C	55.5	0.96 mho/m
Measured Body TSL parameters	(22.0 ± 0.2) °C	54.7 ± 6 %	0.98 mho/m ± 6 %
Body TSL temperature change during test	< 0.5 °C	----	----

SAR result with Body TSL

SAR averaged over 1 cm³ (1 g) of Body TSL	Condition	
SAR measured	250 mW input power	2.18 W/kg
SAR for nominal Body TSL parameters	normalized to 1W	8.56 W/kg ± 17.0 % (k=2)

SAR averaged over 10 cm³ (10 g) of Body TSL	condition	
SAR measured	250 mW input power	1.44 W/kg
SAR for nominal Body TSL parameters	normalized to 1W	5.68 W/kg ± 16.5 % (k=2)

Appendix (Additional assessments outside the scope of SCS 0108)

Antenna Parameters with Head TSL

Impedance, transformed to feed point	54.2 Ω - 0.9 j Ω
Return Loss	- 27.7 dB

Antenna Parameters with Body TSL

Impedance, transformed to feed point	50.1 Ω - 2.3 j Ω
Return Loss	- 32.9 dB

General Antenna Parameters and Design

Electrical Delay (one direction)	1.035 ns
----------------------------------	----------

After long term use with 100W radiated power, only a slight warming of the dipole near the feedpoint can be measured.

The dipole is made of standard semirigid coaxial cable. The center conductor of the feeding line is directly connected to the second arm of the dipole. The antenna is therefore short-circuited for DC-signals. On some of the dipoles, small end caps are added to the dipole arms in order to improve matching when loaded according to the position as explained in the "Measurement Conditions" paragraph. The SAR data are not affected by this change. The overall dipole length is still according to the Standard.

No excessive force must be applied to the dipole arms, because they might bend or the soldered connections near the feedpoint may be damaged.

Additional EUT Data

Manufactured by	SPEAG
Manufactured on	November 08, 2011

DASY5 Validation Report for Head TSL

Date: 16.03.2016

Test Laboratory: SPEAG, Zurich, Switzerland

DUT: Dipole 750 MHz; Type: D750V3; Serial: D750V3 - SN:1054

Communication System: UID 0 - CW; Frequency: 750 MHz

Medium parameters used: $f = 750 \text{ MHz}$; $\sigma = 0.91 \text{ S/m}$; $\epsilon_r = 41.9$; $\rho = 1000 \text{ kg/m}^3$

Measurement Standard: DASY5 (IEEE/IEC/ANSI C63.19-2011)

DASY52 Configuration:

- Probe: EX3DV4 - SN7349; ConvF(10.28, 10.28, 10.28); Calibrated: 31.12.2015;
- Sensor-Surface: 1.4mm (Mechanical Surface Detection)
- Electronics: DAE4 Sn601; Calibrated: 30.12.2015
- Phantom Type: QD000P49AA
- DASY52 52.8.8(1258); SEMCAD X 14.6.10(7372)

Dipole Calibration for Head Tissue EX-Probe/Pin=250 mW, d=15mm/Zoom Scan

(7x7x7)/Cube 0: Measurement grid: dx=5mm, dy=5mm, dz=5mm

Reference Value = 58.13 V/m; Power Drift = 0.02 dB

Peak SAR (extrapolated) = 3.14 W/kg

SAR(1 g) = 2.09 W/kg; SAR(10 g) = 1.37 W/kg

Maximum value of SAR (measured) = 2.78 W/kg

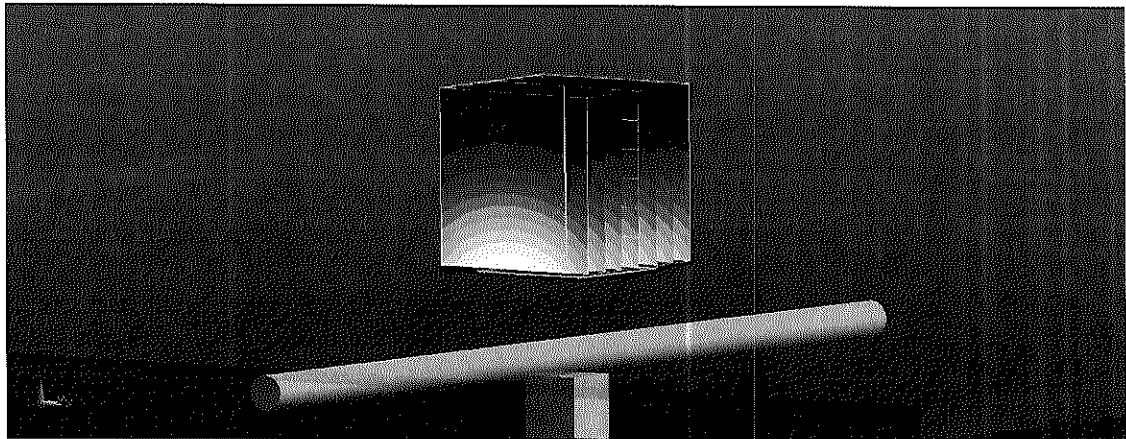
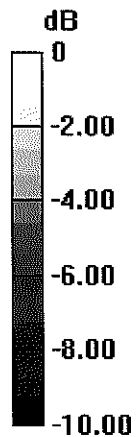

0 dB = 2.78 W/kg = 4.44 dBW/kg

Impedance Measurement Plot for Head TSL

CH1 S11 1 U FS 15 Mar 2016 13:55:57
1: 54.217 Ω -931.64 m Ω 227.78 pF 750.000 000 MHz

*
De1
Ca
Avg
16
H1d

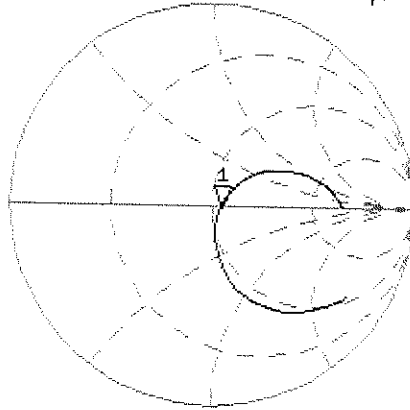

CH2 S11 LOG 5 dB/REF -20 dB 1:-27.652 dB 750.000 000 MHz

Ca
Avg
16
H1d

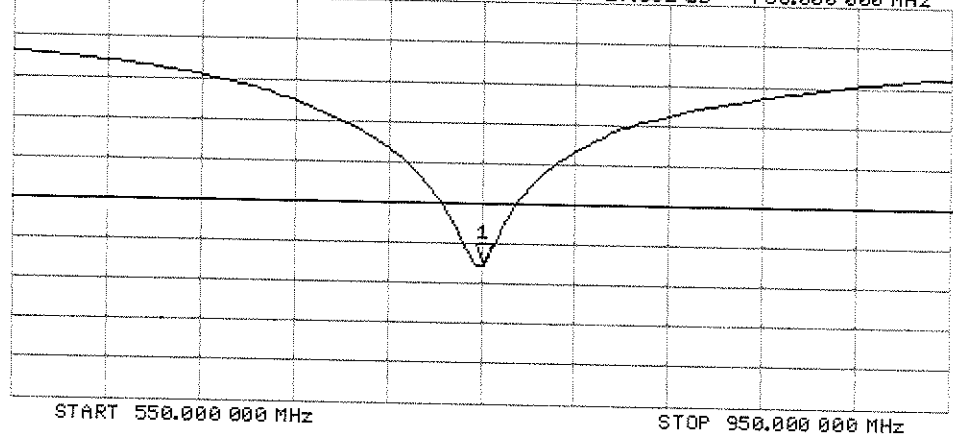

DASY5 Validation Report for Body TSL

Date: 16.03.2016

Test Laboratory: SPEAG, Zurich, Switzerland

DUT: Dipole 750 MHz; Type: D750V3; Serial: D750V3 - SN:1054

Communication System: UID 0 - CW; Frequency: 750 MHz

Medium parameters used: $f = 750$ MHz; $\sigma = 0.98$ S/m; $\epsilon_r = 54.7$; $\rho = 1000$ kg/m³

Measurement Standard: DASY5 (IEEE/IEC/ANSI C63.19-2011)

DASY52 Configuration:

- Probe: EX3DV4 - SN7349; ConvF(9.99, 9.99, 9.99); Calibrated: 31.12.2015;
- Sensor-Surface: 1.4mm (Mechanical Surface Detection)
- Electronics: DAE4 Sn601; Calibrated: 30.12.2015
- Phantom Type: QD000P49AA
- DASY52 52.8.8(1258); SEMCAD X 14.6.10(7372)

Dipole Calibration for Body Tissue EX-Probe/Pin=250 mW, d=15mm/Zoom Scan

(7x7x7)/Cube 0: Measurement grid: dx=5mm, dy=5mm, dz=5mm

Reference Value = 56.90 V/m; Power Drift = 0.00 dB

Peak SAR (extrapolated) = 3.24 W/kg

SAR(1 g) = 2.18 W/kg; SAR(10 g) = 1.44 W/kg

Maximum value of SAR (measured) = 2.89 W/kg

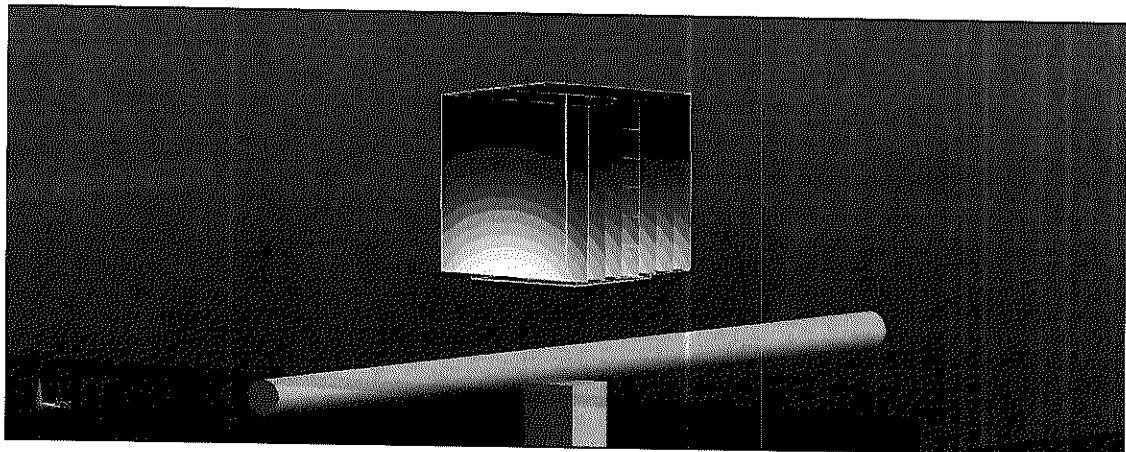
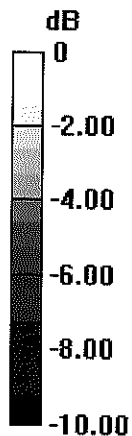

0 dB = 2.89 W/kg = 4.61 dBW/kg

Impedance Measurement Plot for Body TSL

CH1 S11 1 U FS 1: 50.104 Ω -2.2773 Ω 93.102 pF 16 Mar 2016 11:38:16
 750.000 000 MHz

*
De1

CA

Avg
16

H1d

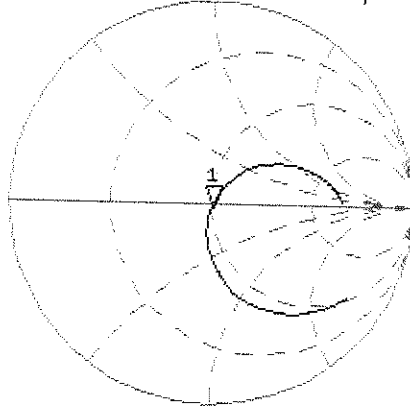

CH2 S11 LOG 5 dB/REF -20 dB 1: -32.854 dB 750.000 000 MHz

CA

Avg
16

H1d

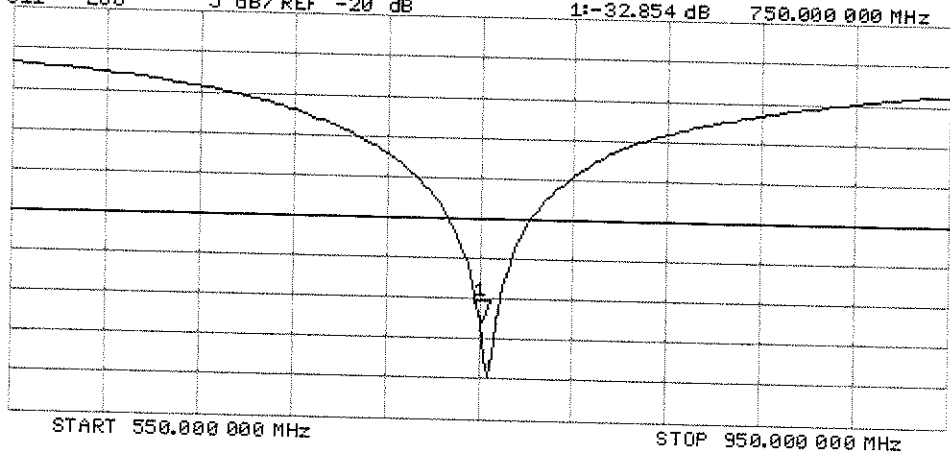



Accredited by the Swiss Accreditation Service (SAS)
The Swiss Accreditation Service is one of the signatories to the EA
Multilateral Agreement for the recognition of calibration certificates

Accreditation No.: **SCS 0108**

Client **PC Test**

Certificate No: **D835V2-4d047_Jul16**

CALIBRATION CERTIFICATE

Object **D835V2 - SN:4d047**

Calibration procedure(s) **QA CAL-05.v9**
Calibration procedure for dipole validation kits above 700 MHz

Calibration date: **July 13, 2016**

*BNV
7/16/2016*

This calibration certificate documents the traceability to national standards, which realize the physical units of measurements (SI).
The measurements and the uncertainties with confidence probability are given on the following pages and are part of the certificate.

All calibrations have been conducted in the closed laboratory facility: environment temperature (22 ± 3)°C and humidity < 70%.

Calibration Equipment used (M&TE critical for calibration)

Primary Standards	ID #	Cal Date (Certificate No.)	Scheduled Calibration
Power meter NRP	SN: 104778	06-Apr-16 (No. 217-02288/02289)	Apr-17
Power sensor NRP-Z91	SN: 103244	06-Apr-16 (No. 217-02288)	Apr-17
Power sensor NRP-Z91	SN: 103245	06-Apr-16 (No. 217-02289)	Apr-17
Reference 20 dB Attenuator	SN: 5058 (20k)	05-Apr-16 (No. 217-02292)	Apr-17
Type-N mismatch combination	SN: 5047.2 / 06327	05-Apr-16 (No. 217-02295)	Apr-17
Reference Probe EX3DV4	SN: 7349	15-Jun-16 (No. EX3-7349_Jun16)	Jun-17
DAE4	SN: 601	30-Dec-15 (No. DAE4-601_Dec15)	Dec-16
Secondary Standards	ID #	Check Date (in house)	Scheduled Check
Power meter EPM-442A	SN: GB37480704	07-Oct-15 (No. 217-02222)	In house check: Oct-16
Power sensor HP 8481A	SN: US37292783	07-Oct-15 (No. 217-02222)	In house check: Oct-16
Power sensor HP 8481A	SN: MY41092317	07-Oct-15 (No. 217-02223)	In house check: Oct-16
RF generator R&S SMT-06	SN: 100972	15-Jun-15 (in house check Jun-15)	In house check: Oct-16
Network Analyzer HP 8753E	SN: US37390585	18-Oct-01 (in house check Oct-15)	in house check: Oct-16

Calibrated by: **Jeton Kastrali** Name: **Jeton Kastrali** Function: **Laboratory Technician**

Signature:

Approved by: **Katja Pokovic** Name: **Katja Pokovic** Function: **Technical Manager**

Signature:

Issued: July 13, 2016

This calibration certificate shall not be reproduced except in full without written approval of the laboratory.



Accredited by the Swiss Accreditation Service (SAS)

The Swiss Accreditation Service is one of the signatories to the EA
Multilateral Agreement for the recognition of calibration certificates

Accreditation No.: **SCS 0108**

Glossary:

TSL	tissue simulating liquid
ConvF	sensitivity in TSL / NORM x,y,z
N/A	not applicable or not measured

Calibration is Performed According to the Following Standards:

- IEEE Std 1528-2013, "IEEE Recommended Practice for Determining the Peak Spatial-Averaged Specific Absorption Rate (SAR) in the Human Head from Wireless Communications Devices: Measurement Techniques", June 2013
- IEC 62209-1, "Procedure to measure the Specific Absorption Rate (SAR) for hand-held devices used in close proximity to the ear (frequency range of 300 MHz to 3 GHz)", February 2005
- IEC 62209-2, "Procedure to determine the Specific Absorption Rate (SAR) for wireless communication devices used in close proximity to the human body (frequency range of 30 MHz to 6 GHz)", March 2010
- KDB 865664, "SAR Measurement Requirements for 100 MHz to 6 GHz"

Additional Documentation:

- DASY4/5 System Handbook

Methods Applied and Interpretation of Parameters:

- Measurement Conditions:** Further details are available from the Validation Report at the end of the certificate. All figures stated in the certificate are valid at the frequency indicated.
- Antenna Parameters with TSL:** The dipole is mounted with the spacer to position its feed point exactly below the center marking of the flat phantom section, with the arms oriented parallel to the body axis.
- Feed Point Impedance and Return Loss:** These parameters are measured with the dipole positioned under the liquid filled phantom. The impedance stated is transformed from the measurement at the SMA connector to the feed point. The Return Loss ensures low reflected power. No uncertainty required.
- Electrical Delay:** One-way delay between the SMA connector and the antenna feed point. No uncertainty required.
- SAR measured:** SAR measured at the stated antenna input power.
- SAR normalized:** SAR as measured, normalized to an input power of 1 W at the antenna connector.
- SAR for nominal TSL parameters:** The measured TSL parameters are used to calculate the nominal SAR result.

The reported uncertainty of measurement is stated as the standard uncertainty of measurement multiplied by the coverage factor $k=2$, which for a normal distribution corresponds to a coverage probability of approximately 95%.

Measurement Conditions

DASY system configuration, as far as not given on page 1.

DASY Version	DASY5	V52.8.8
Extrapolation	Advanced Extrapolation	
Phantom	Modular Flat Phantom	
Distance Dipole Center - TSL	15 mm	with Spacer
Zoom Scan Resolution	dx, dy, dz = 5 mm	
Frequency	835 MHz \pm 1 MHz	

Head TSL parameters

The following parameters and calculations were applied.

	Temperature	Permittivity	Conductivity
Nominal Head TSL parameters	22.0 °C	41.5	0.90 mho/m
Measured Head TSL parameters	(22.0 \pm 0.2) °C	40.6 \pm 6 %	0.94 mho/m \pm 6 %
Head TSL temperature change during test	< 0.5 °C	----	----

SAR result with Head TSL

SAR averaged over 1 cm ³ (1 g) of Head TSL	Condition	
SAR measured	250 mW input power	2.37 W/kg
SAR for nominal Head TSL parameters	normalized to 1W	9.13 W/kg \pm 17.0 % (k=2)

SAR averaged over 10 cm ³ (10 g) of Head TSL	condition	
SAR measured	250 mW input power	1.53 W/kg
SAR for nominal Head TSL parameters	normalized to 1W	5.95 W/kg \pm 16.5 % (k=2)

Body TSL parameters

The following parameters and calculations were applied.

	Temperature	Permittivity	Conductivity
Nominal Body TSL parameters	22.0 °C	55.2	0.97 mho/m
Measured Body TSL parameters	(22.0 \pm 0.2) °C	54.9 \pm 6 %	1.01 mho/m \pm 6 %
Body TSL temperature change during test	< 0.5 °C	----	----

SAR result with Body TSL

SAR averaged over 1 cm ³ (1 g) of Body TSL	Condition	
SAR measured	250 mW input power	2.47 W/kg
SAR for nominal Body TSL parameters	normalized to 1W	9.57 W/kg \pm 17.0 % (k=2)

SAR averaged over 10 cm ³ (10 g) of Body TSL	condition	
SAR measured	250 mW input power	1.60 W/kg
SAR for nominal Body TSL parameters	normalized to 1W	6.24 W/kg \pm 16.5 % (k=2)

Appendix (Additional assessments outside the scope of SCS 0108)

Antenna Parameters with Head TSL

Impedance, transformed to feed point	49.8 Ω - 5.9 j Ω
Return Loss	- 24.5 dB

Antenna Parameters with Body TSL

Impedance, transformed to feed point	45.8 Ω - 8.2 j Ω
Return Loss	- 20.3 dB

General Antenna Parameters and Design

Electrical Delay (one direction)	None ns
----------------------------------	---------

After long term use with 100W radiated power, only a slight warming of the dipole near the feedpoint can be measured.

The dipole is made of standard semirigid coaxial cable. The center conductor of the feeding line is directly connected to the second arm of the dipole. The antenna is therefore short-circuited for DC-signals. On some of the dipoles, small end caps are added to the dipole arms in order to improve matching when loaded according to the position as explained in the "Measurement Conditions" paragraph. The SAR data are not affected by this change. The overall dipole length is still according to the Standard.

No excessive force must be applied to the dipole arms, because they might bend or the soldered connections near the feedpoint may be damaged.

Additional EUT Data

Manufactured by	SPEAG
Manufactured on	August 16, 2006

DASY5 Validation Report for Head TSL

Date: 13.07.2016

Test Laboratory: SPEAG, Zurich, Switzerland

DUT: Dipole 835 MHz D835V2; Type: D835V2; Serial: D835V2 - SN:4d047

Communication System: UID 0 - CW; Frequency: 835 MHz

Medium parameters used: $f = 835$ MHz; $\sigma = 0.94$ S/m; $\epsilon_r = 40.6$; $\rho = 1000$ kg/m³

Phantom section: Flat Section

Measurement Standard: DASY5 (IEEE/IEC/ANSI C63.19-2011)

DASY52 Configuration:

- Probe: EX3DV4 - SN7349; ConvF(9.72, 9.72, 9.72); Calibrated: 15.06.2016;
- Sensor-Surface: 1.4mm (Mechanical Surface Detection)
- Electronics: DAE4 Sn601; Calibrated: 30.12.2015
- Phantom: Flat Phantom 4.9L; Type: QD000P49AA; Serial: 1001
- DASY52 52.8.8(1258); SEMCAD X 14.6.10(7372)

Dipole Calibration for Head Tissue/Pin=250 mW, d=15mm/Zoom Scan (7x7x7)/Cube 0:

Measurement grid: dx=5mm, dy=5mm, dz=5mm

Reference Value = 60.98 V/m; Power Drift = 0.01 dB

Peak SAR (extrapolated) = 3.56 W/kg

SAR(1 g) = 2.37 W/kg; SAR(10 g) = 1.53 W/kg

Maximum value of SAR (measured) = 3.17 W/kg

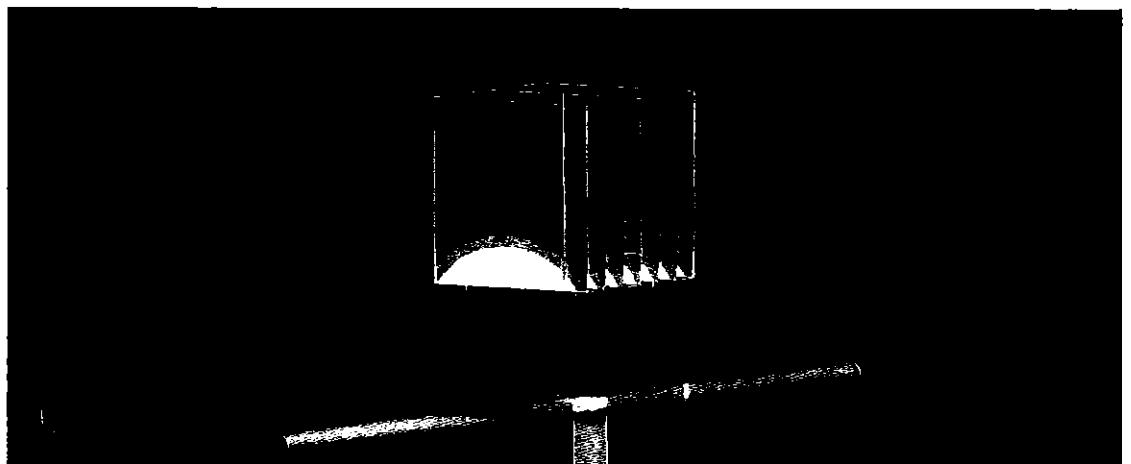
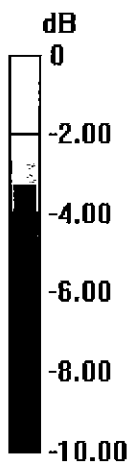

0 dB = 3.17 W/kg = 5.01 dBW/kg

Impedance Measurement Plot for Head TSL

13 Jul 2016 12:00:27

CH1 S11 1 U FS

1: 49.820 Ω -5.9316 Ω 32.134 pF

835.000 000 MHz

*
De1
CA

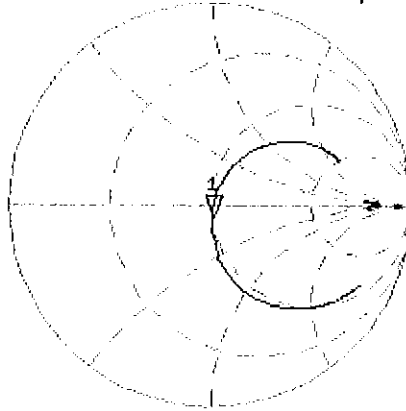

Avg
16

H1d

CH2 S11 LOG

5 dB/REF -20 dB

1:-24.525 dB

835.000 000 MHz

CA

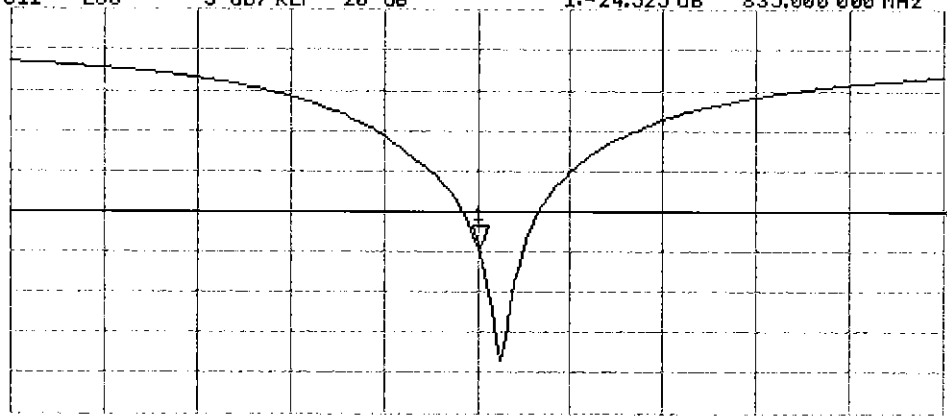

Avg
16

H1d

START 635.000 000 MHz

STOP 1 035.000 000 MHz

DASY5 Validation Report for Body TSL

Date: 13.07.2016

Test Laboratory: SPEAG, Zurich, Switzerland

DUT: Dipole 835 MHz D835V2; Type: D835V2; Serial: D835V2 - SN:4d047

Communication System: UID 0 - CW; Frequency: 835 MHz

Medium parameters used: $f = 835$ MHz; $\sigma = 1.01$ S/m; $\epsilon_r = 54.9$; $\rho = 1000$ kg/m³

Phantom section: Flat Section

Measurement Standard: DASY5 (IEEE/IEC/ANSI C63.19-2011)

DASY52 Configuration:

- Probe: EX3DV4 - SN7349; ConvF(9.73, 9.73, 9.73); Calibrated: 15.06.2016;
- Sensor-Surface: 1.4mm (Mechanical Surface Detection)
- Electronics: DAE4 Sn601; Calibrated: 30.12.2015
- Phantom: Flat Phantom 4.9L; Type: QD000P49AA; Serial: 1001
- DASY52 52.8.8(1258); SEMCAD X 14.6.10(7372)

Dipole Calibration for Body Tissue/Pin=250 mW, d=15mm/Zoom Scan (7x7x7)/Cube 0:

Measurement grid: dx=5mm, dy=5mm, dz=5mm

Reference Value = 59.88 V/m; Power Drift = -0.01 dB

Peak SAR (extrapolated) = 3.67 W/kg

SAR(1 g) = 2.47 W/kg; SAR(10 g) = 1.6 W/kg

Maximum value of SAR (measured) = 3.27 W/kg

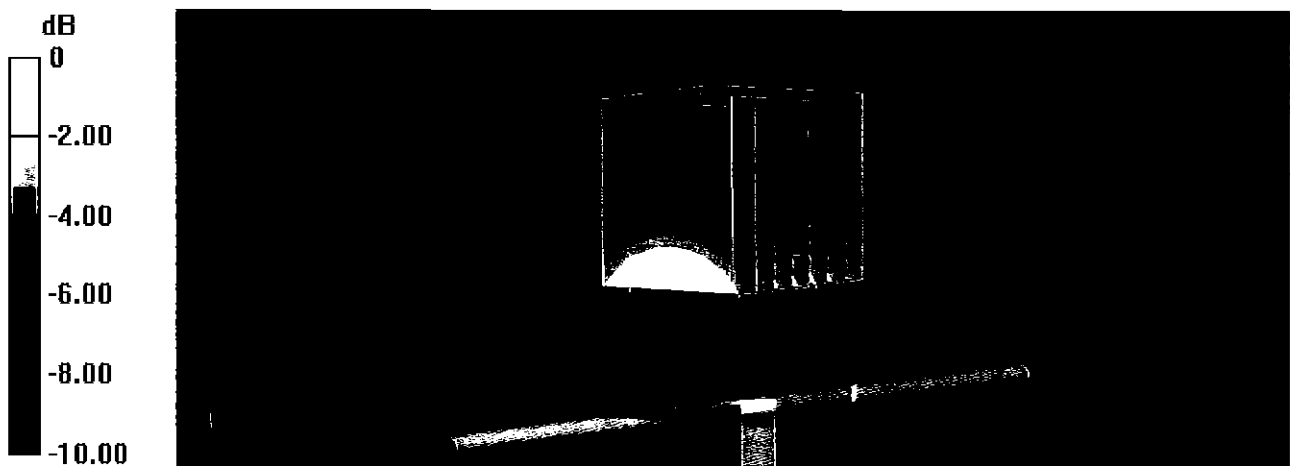

0 dB = 3.27 W/kg = 5.15 dBW/kg

Impedance Measurement Plot for Body TSL

13 Jul 2016 13:35:41
CH1 S11 1 U FS 1: 45.793 Ω -8.1777 Ω 23.308 pF 835.000 000 MHz

*
Del

CA

Avg
16

H1 d

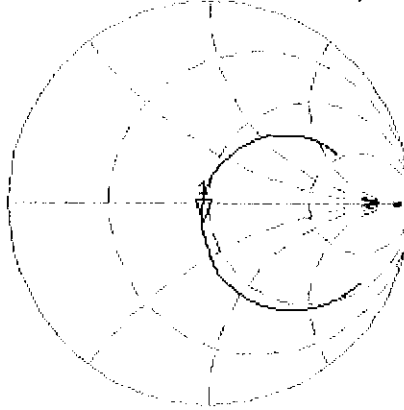

CH2 S11 LOG 5 dB/ REF -20 dB 1: -20.332 dB 835.000 000 MHz

CA

H1 d

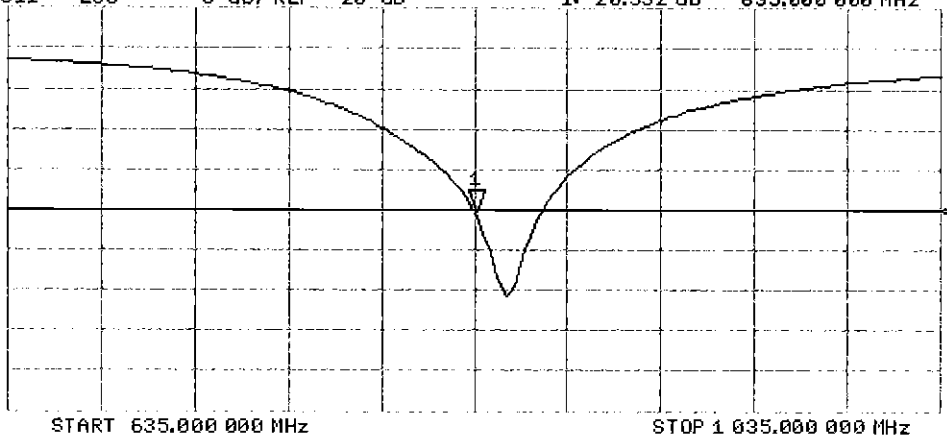



Accredited by the Swiss Accreditation Service (SAS)
The Swiss Accreditation Service is one of the signatories to the EA
Multilateral Agreement for the recognition of calibration certificates

Accreditation No.: **SCS 0108**

Client **PC Test**

Certificate No: **D1750V2-1148_May16**

CALIBRATION CERTIFICATE

Object **D1750V2 - SN: 1148**

Calibration procedure(s) **QA CAL-05.v9
Calibration procedure for dipole validation kits above 700 MHz**

Calibration date: **May 09, 2016**

BNV
5/17/2016

This calibration certificate documents the traceability to national standards, which realize the physical units of measurements (SI).
The measurements and the uncertainties with confidence probability are given on the following pages and are part of the certificate.

All calibrations have been conducted in the closed laboratory facility: environment temperature (22 ± 3)°C and humidity < 70%.

Calibration Equipment used (M&TE critical for calibration)

Primary Standards	ID #	Cal Date (Certificate No.)	Scheduled Calibration
Power meter NRP	SN: 104778	06-Apr-16 (No. 217-02288/02289)	Apr-17
Power sensor NRP-Z91	SN: 103244	06-Apr-16 (No. 217-02288)	Apr-17
Power sensor NRP-Z91	SN: 103245	06-Apr-16 (No. 217-02289)	Apr-17
Reference 20 dB Attenuator	SN: 5058 (20k)	05-Apr-16 (No. 217-02292)	Apr-17
Type-N mismatch combination	SN: 5047.2 / 06327	05-Apr-16 (No. 217-02295)	Apr-17
Reference Probe EX3DV4	SN: 7349	31-Dec-15 (No. EX3-7349_Dec15)	Dec-16
DAE4	SN: 601	30-Dec-15 (No. DAE4-601_Dec15)	Dec-16
Secondary Standards	ID #	Check Date (in house)	Scheduled Check
Power meter EPM-442A	SN: GB37480704	07-Oct-15 (No. 217-02222)	In house check: Oct-16
Power sensor HP 8481A	SN: US37292783	07-Oct-15 (No. 217-02222)	In house check: Oct-16
Power sensor HP 8481A	SN: MY41092317	07-Oct-15 (No. 217-02223)	In house check: Oct-16
RF generator R&S SMT-06	SN: 100972	15-Jun-15 (in house check Jun-15)	In house check: Oct-16
Network Analyzer HP 8753E	SN: US37390585	18-Oct-01 (in house check Oct-15)	In house check: Oct-16

Calibrated by: **Michael Weber** Function: **Laboratory Technician**

Signature
M. Weber

Approved by: **Katja Pokovic** Technical Manager

[Signature]

Issued: May 11, 2016

This calibration certificate shall not be reproduced except in full without written approval of the laboratory.



Accredited by the Swiss Accreditation Service (SAS)
The Swiss Accreditation Service is one of the signatories to the EA
Multilateral Agreement for the recognition of calibration certificates

Accreditation No.: **SCS 0108**

Glossary:

TSL	tissue simulating liquid
ConvF	sensitivity in TSL / NORM x,y,z
N/A	not applicable or not measured

Calibration is Performed According to the Following Standards:

- a) IEEE Std 1528-2013, "IEEE Recommended Practice for Determining the Peak Spatial-Averaged Specific Absorption Rate (SAR) in the Human Head from Wireless Communications Devices: Measurement Techniques", June 2013
- b) IEC 62209-1, "Procedure to measure the Specific Absorption Rate (SAR) for hand-held devices used in close proximity to the ear (frequency range of 300 MHz to 3 GHz)", February 2005
- c) IEC 62209-2, "Procedure to determine the Specific Absorption Rate (SAR) for wireless communication devices used in close proximity to the human body (frequency range of 30 MHz to 6 GHz)", March 2010
- d) KDB 865664, "SAR Measurement Requirements for 100 MHz to 6 GHz"

Additional Documentation:

- e) DASY4/5 System Handbook

Methods Applied and Interpretation of Parameters:

- *Measurement Conditions:* Further details are available from the Validation Report at the end of the certificate. All figures stated in the certificate are valid at the frequency indicated.
- *Antenna Parameters with TSL:* The dipole is mounted with the spacer to position its feed point exactly below the center marking of the flat phantom section, with the arms oriented parallel to the body axis.
- *Feed Point Impedance and Return Loss:* These parameters are measured with the dipole positioned under the liquid filled phantom. The impedance stated is transformed from the measurement at the SMA connector to the feed point. The Return Loss ensures low reflected power. No uncertainty required.
- *Electrical Delay:* One-way delay between the SMA connector and the antenna feed point. No uncertainty required.
- *SAR measured:* SAR measured at the stated antenna input power.
- *SAR normalized:* SAR as measured, normalized to an input power of 1 W at the antenna connector.
- *SAR for nominal TSL parameters:* The measured TSL parameters are used to calculate the nominal SAR result.

The reported uncertainty of measurement is stated as the standard uncertainty of measurement multiplied by the coverage factor $k=2$, which for a normal distribution corresponds to a coverage probability of approximately 95%.

Measurement Conditions

DASY system configuration, as far as not given on page 1.

DASY Version	DASY5	V52.8.8
Extrapolation	Advanced Extrapolation	
Phantom	Modular Flat Phantom	
Distance Dipole Center - TSL	10 mm	with Spacer
Zoom Scan Resolution	dx, dy, dz = 5 mm	
Frequency	1750 MHz \pm 1 MHz	

Head TSL parameters

The following parameters and calculations were applied.

	Temperature	Permittivity	Conductivity
Nominal Head TSL parameters	22.0 °C	40.1	1.37 mho/m
Measured Head TSL parameters	(22.0 \pm 0.2) °C	39.7 \pm 6 %	1.36 mho/m \pm 6 %
Head TSL temperature change during test	< 0.5 °C	----	----

SAR result with Head TSL

SAR averaged over 1 cm ³ (1 g) of Head TSL	Condition	
SAR measured	250 mW input power	9.03 W/kg
SAR for nominal Head TSL parameters	normalized to 1W	36.2 W/kg \pm 17.0 % (k=2)

SAR averaged over 10 cm ³ (10 g) of Head TSL	condition	
SAR measured	250 mW input power	4.78 W/kg
SAR for nominal Head TSL parameters	normalized to 1W	19.1 W/kg \pm 16.5 % (k=2)

Body TSL parameters

The following parameters and calculations were applied.

	Temperature	Permittivity	Conductivity
Nominal Body TSL parameters	22.0 °C	53.4	1.49 mho/m
Measured Body TSL parameters	(22.0 \pm 0.2) °C	53.8 \pm 6 %	1.50 mho/m \pm 6 %
Body TSL temperature change during test	< 0.5 °C	----	----

SAR result with Body TSL

SAR averaged over 1 cm ³ (1 g) of Body TSL	Condition	
SAR measured	250 mW input power	9.30 W/kg
SAR for nominal Body TSL parameters	normalized to 1W	37.1 W/kg \pm 17.0 % (k=2)

SAR averaged over 10 cm ³ (10 g) of Body TSL	condition	
SAR measured	250 mW input power	4.93 W/kg
SAR for nominal Body TSL parameters	normalized to 1W	19.7 W/kg \pm 16.5 % (k=2)

Appendix (Additional assessments outside the scope of SCS 0108)

Antenna Parameters with Head TSL

Impedance, transformed to feed point	49.9 Ω - 0.7 j Ω
Return Loss	- 43.3 dB

Antenna Parameters with Body TSL

Impedance, transformed to feed point	46.2 Ω - 1.4 j Ω
Return Loss	- 27.5 dB

General Antenna Parameters and Design

Electrical Delay (one direction)	1.221 ns
----------------------------------	----------

After long term use with 100W radiated power, only a slight warming of the dipole near the feedpoint can be measured.

The dipole is made of standard semirigid coaxial cable. The center conductor of the feeding line is directly connected to the second arm of the dipole. The antenna is therefore short-circuited for DC-signals. On some of the dipoles, small end caps are added to the dipole arms in order to improve matching when loaded according to the position as explained in the "Measurement Conditions" paragraph. The SAR data are not affected by this change. The overall dipole length is still according to the Standard.

No excessive force must be applied to the dipole arms, because they might bend or the soldered connections near the feedpoint may be damaged.

Additional EUT Data

Manufactured by	SPEAG
Manufactured on	September 30, 2014

DASY5 Validation Report for Head TSL

Date: 09.05.2016

Test Laboratory: SPEAG, Zurich, Switzerland

DUT: Dipole 1750 MHz; Type: D1750V2; Serial: D1750V2 - SN: 1148

Communication System: UID 0 - CW; Frequency: 1750 MHz

Medium parameters used: $f = 1750$ MHz; $\sigma = 1.36$ S/m; $\epsilon_r = 39.7$; $\rho = 1000$ kg/m³

Phantom section: Flat Section

Measurement Standard: DASY5 (IEEE/IEC/ANSI C63.19-2011)

DASY52 Configuration:

- Probe: EX3DV4 - SN7349; ConvF(8.54, 8.54, 8.54); Calibrated: 31.12.2015;
- Sensor-Surface: 1.4mm (Mechanical Surface Detection)
- Electronics: DAE4 Sn601; Calibrated: 30.12.2015
- Phantom: Flat Phantom 5.0 (front); Type: QD000P50AA; Serial: 1001
- DASY52 52.8.8(1258); SEMCAD X 14.6.10(7372)

Dipole Calibration for Head Tissue/Pin=250 mW, d=10mm/Zoom Scan (7x7x7)/Cube 0:

Measurement grid: dx=5mm, dy=5mm, dz=5mm

Reference Value = 103.5 V/m; Power Drift = 0.04 dB

Peak SAR (extrapolated) = 16.7 W/kg

SAR(1 g) = 9.03 W/kg; SAR(10 g) = 4.78 W/kg

Maximum value of SAR (measured) = 13.6 W/kg

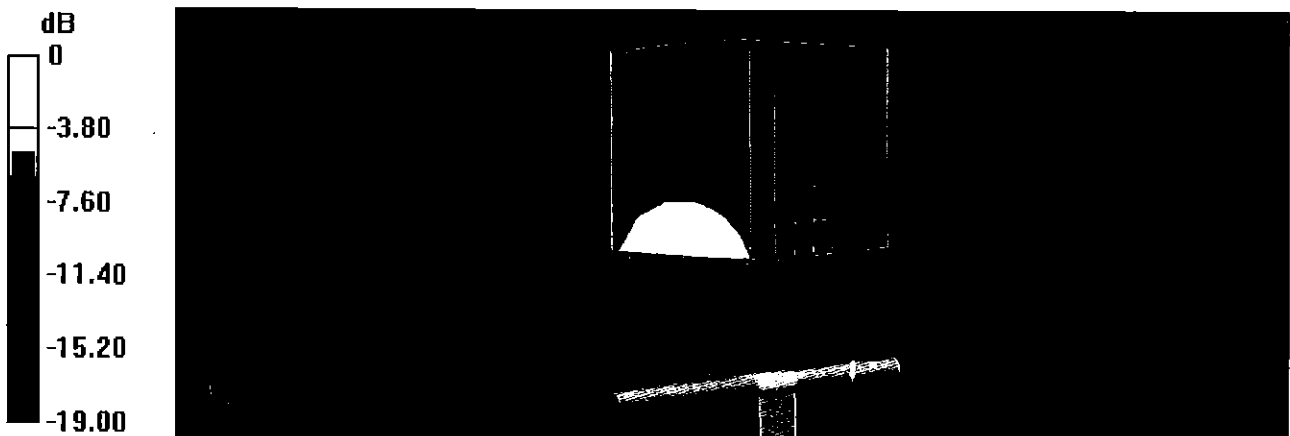

0 dB = 13.6 W/kg = 11.34 dBW/kg

Impedance Measurement Plot for Head TSL

9 May 2016 11:49:12
[CH1] S11 1 U FS 1: 49.912 Ω -679.69 m Ω 133.81 pF 1 750.000 000 MHz

*
De1
CA
Avg
16
H1d

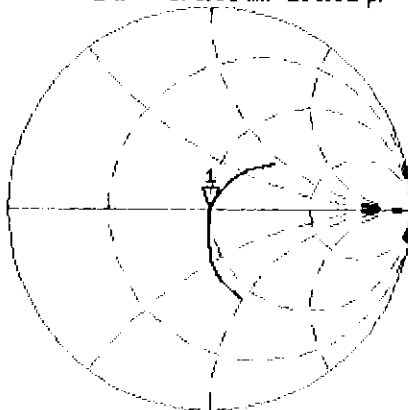

CH2 S11 LOG 5 dB/REF -20 dB 1: -43.269 dB 1 750.000 000 MHz

De1
CA
Avg
16
H1d

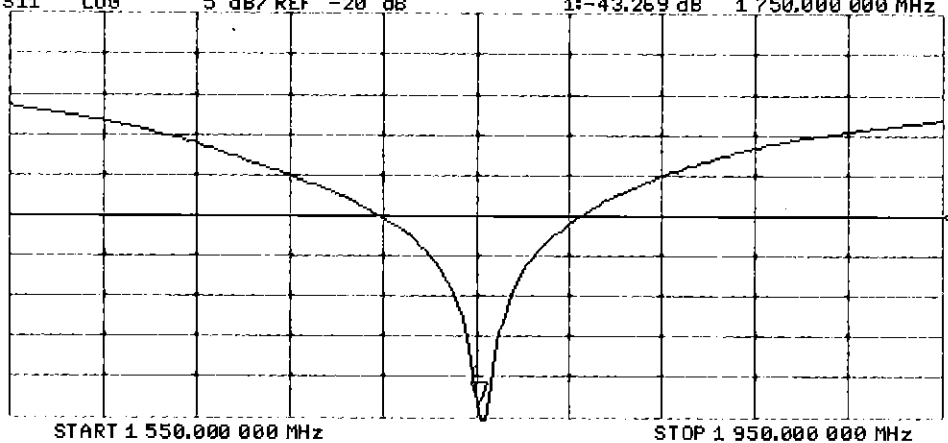

DASY5 Validation Report for Body TSL

Date: 09.05.2016

Test Laboratory: SPEAG, Zurich, Switzerland

DUT: Dipole 1750 MHz; Type: D1750V2; Serial: D1750V2 - SN: 1148

Communication System: UID 0 - CW; Frequency: 1750 MHz

Medium parameters used: $f = 1750$ MHz; $\sigma = 1.5$ S/m; $\epsilon_r = 53.8$; $\rho = 1000$ kg/m³

Phantom section: Flat Section

Measurement Standard: DASY5 (IEEE/IEC/ANSI C63.19-2011)

DASY52 Configuration:

- Probe: EX3DV4 - SN7349; ConvF(8.25, 8.25, 8.25); Calibrated: 31.12.2015;
- Sensor-Surface: 1.4mm (Mechanical Surface Detection)
- Electronics: DAE4 Sn601; Calibrated: 30.12.2015
- Phantom: Flat Phantom 5.0 (back); Type: QD000P50AA; Serial: 1002
- DASY52 52.8.8(1258); SEMCAD X 14.6.10(7372)

Dipole Calibration for Body Tissue/Pin=250 mW, d=10mm/Zoom Scan (7x7x7)/Cube 0:

Measurement grid: dx=5mm, dy=5mm, dz=5mm

Reference Value = 102.0 V/m; Power Drift = -0.08 dB

Peak SAR (extrapolated) = 16.6 W/kg

SAR(1 g) = 9.3 W/kg; SAR(10 g) = 4.93 W/kg

Maximum value of SAR (measured) = 14.1 W/kg

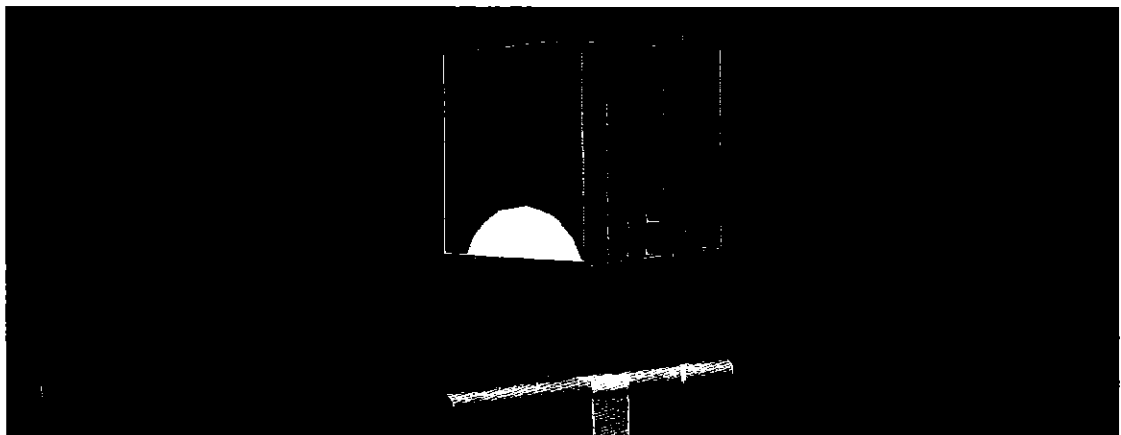
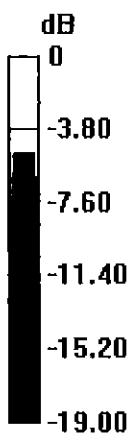

0 dB = 14.1 W/kg = 11.49 dBW/kg

Impedance Measurement Plot for Body TSL

9 May 2016 11:48:41
[CH1] S11 1 U FS 1: 46.205 Ω -1.4258 Ω 63.787 pF 1 750.000 000 MHz

*
De1

CA

Avg
16

H1d

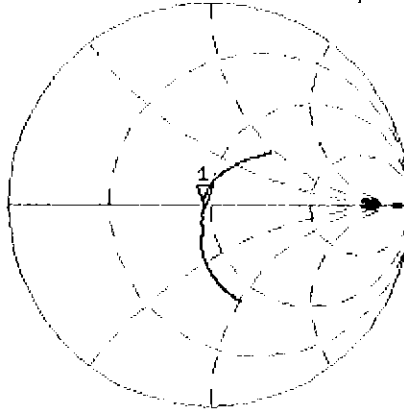

CH2 S11 LOG 5 dB/REF -20 dB 1:-27.503 dB 1 750.000 000 MHz

De1

CA

Avg
16

H1d

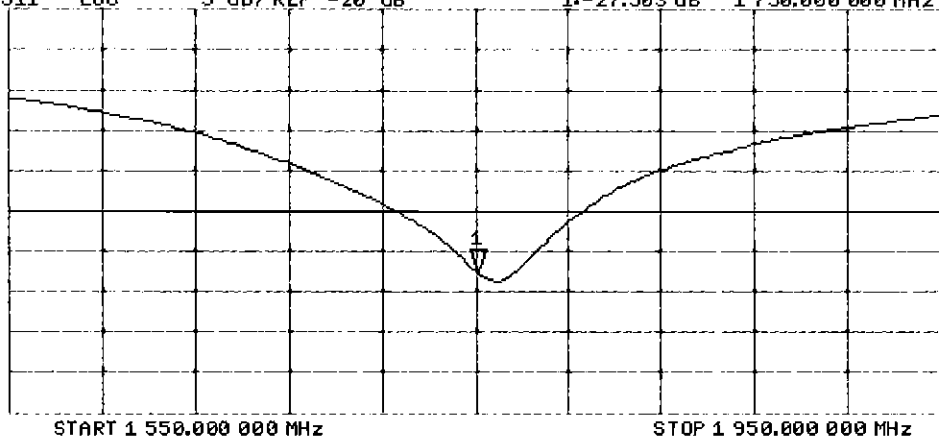



Accredited by the Swiss Accreditation Service (SAS)
The Swiss Accreditation Service is one of the signatories to the EA
Multilateral Agreement for the recognition of calibration certificates

Accreditation No.: **SCS 0108**

Client **PC Test**

Certificate No: **D1900V2-5d149_Jul16**

CALIBRATION CERTIFICATE

Object **D1900V2 - SN:5d149**

Calibration procedure(s) **QA CAL-05.v9**
Calibration procedure for dipole validation kits above 700 MHz

Calibration date: **July 15, 2016**

PNV
07/27/2016

This calibration certificate documents the traceability to national standards, which realize the physical units of measurements (SI).
The measurements and the uncertainties with confidence probability are given on the following pages and are part of the certificate.

All calibrations have been conducted in the closed laboratory facility: environment temperature (22 ± 3)°C and humidity < 70%.

Calibration Equipment used (M&TE critical for calibration)

Primary Standards	ID #	Cal Date (Certificate No.)	Scheduled Calibration
Power meter NRP	SN: 104778	06-Apr-16 (No. 217-02288/02289)	Apr-17
Power sensor NRP-Z91	SN: 103244	06-Apr-16 (No. 217-02288)	Apr-17
Power sensor NRP-Z91	SN: 103245	06-Apr-16 (No. 217-02289)	Apr-17
Reference 20 dB Attenuator	SN: 5058 (20k)	05-Apr-16 (No. 217-02292)	Apr-17
Type-N mismatch combination	SN: 5047.2 / 06327	05-Apr-16 (No. 217-02295)	Apr-17
Reference Probe EX3DV4	SN: 7349	15-Jun-16 (No. EX3-7349_Jun16)	Jun-17
DAE4	SN: 601	30-Dec-15 (No. DAE4-601_Dec15)	Dec-16

Secondary Standards	ID #	Check Date (in house)	Scheduled Check
Power meter EPM-442A	SN: GB37480704	07-Oct-15 (No. 217-02222)	In house check: Oct-16
Power sensor HP 8481A	SN: US37292783	07-Oct-15 (No. 217-02222)	In house check: Oct-16
Power sensor HP 8481A	SN: MY41092317	07-Oct-15 (No. 217-02223)	In house check: Oct-16
RF generator R&S SMT-06	SN: 100972	15-Jun-15 (in house check Jun-15)	In house check: Oct-16
Network Analyzer HP 8753E	SN: US37390585	18-Oct-01 (in house check Oct-15)	In house check: Oct-16

Calibrated by: **Claudio Leubler** Name: **Claudio Leubler** Function: **Laboratory Technician**

Approved by: **Katja Pokovic** Name: **Katja Pokovic** Function: **Technical Manager**

Signature
[Handwritten Signature]

[Handwritten Signature]

Issued: July 19, 2016

This calibration certificate shall not be reproduced except in full without written approval of the laboratory.



Accredited by the Swiss Accreditation Service (SAS)
The Swiss Accreditation Service is one of the signatories to the EA
Multilateral Agreement for the recognition of calibration certificates

Accreditation No.: **SCS 0108**

Glossary:

TSL	tissue simulating liquid
ConvF	sensitivity in TSL / NORM x,y,z
N/A	not applicable or not measured

Calibration is Performed According to the Following Standards:

- a) IEEE Std 1528-2013, "IEEE Recommended Practice for Determining the Peak Spatial-Averaged Specific Absorption Rate (SAR) in the Human Head from Wireless Communications Devices: Measurement Techniques", June 2013
- b) IEC 62209-1, "Procedure to measure the Specific Absorption Rate (SAR) for hand-held devices used in close proximity to the ear (frequency range of 300 MHz to 3 GHz)", February 2005
- c) IEC 62209-2, "Procedure to determine the Specific Absorption Rate (SAR) for wireless communication devices used in close proximity to the human body (frequency range of 30 MHz to 6 GHz)", March 2010
- d) KDB 865664, "SAR Measurement Requirements for 100 MHz to 6 GHz"

Additional Documentation:

- e) DASY4/5 System Handbook

Methods Applied and Interpretation of Parameters:

- *Measurement Conditions:* Further details are available from the Validation Report at the end of the certificate. All figures stated in the certificate are valid at the frequency indicated.
- *Antenna Parameters with TSL:* The dipole is mounted with the spacer to position its feed point exactly below the center marking of the flat phantom section, with the arms oriented parallel to the body axis.
- *Feed Point Impedance and Return Loss:* These parameters are measured with the dipole positioned under the liquid filled phantom. The impedance stated is transformed from the measurement at the SMA connector to the feed point. The Return Loss ensures low reflected power. No uncertainty required.
- *Electrical Delay:* One-way delay between the SMA connector and the antenna feed point. No uncertainty required.
- *SAR measured:* SAR measured at the stated antenna input power.
- *SAR normalized:* SAR as measured, normalized to an input power of 1 W at the antenna connector.
- *SAR for nominal TSL parameters:* The measured TSL parameters are used to calculate the nominal SAR result.

The reported uncertainty of measurement is stated as the standard uncertainty of measurement multiplied by the coverage factor $k=2$, which for a normal distribution corresponds to a coverage probability of approximately 95%.

Measurement Conditions

DASY system configuration, as far as not given on page 1.

DASY Version	DASY5	V52.8.8
Extrapolation	Advanced Extrapolation	
Phantom	Modular Flat Phantom	
Distance Dipole Center - TSL	10 mm	with Spacer
Zoom Scan Resolution	dx, dy, dz = 5 mm	
Frequency	1900 MHz \pm 1 MHz	

Head TSL parameters

The following parameters and calculations were applied.

	Temperature	Permittivity	Conductivity
Nominal Head TSL parameters	22.0 °C	40.0	1.40 mho/m
Measured Head TSL parameters	(22.0 \pm 0.2) °C	39.8 \pm 6 %	1.38 mho/m \pm 6 %
Head TSL temperature change during test	< 0.5 °C	----	----

SAR result with Head TSL

SAR averaged over 1 cm ³ (1 g) of Head TSL	Condition	
SAR measured	250 mW input power	9.96 W/kg
SAR for nominal Head TSL parameters	normalized to 1W	40.1 W/kg \pm 17.0 % (k=2)

SAR averaged over 10 cm ³ (10 g) of Head TSL	condition	
SAR measured	250 mW input power	5.23 W/kg
SAR for nominal Head TSL parameters	normalized to 1W	21.0 W/kg \pm 16.5 % (k=2)

Body TSL parameters

The following parameters and calculations were applied.

	Temperature	Permittivity	Conductivity
Nominal Body TSL parameters	22.0 °C	53.3	1.52 mho/m
Measured Body TSL parameters	(22.0 \pm 0.2) °C	52.7 \pm 6 %	1.51 mho/m \pm 6 %
Body TSL temperature change during test	< 0.5 °C	----	----

SAR result with Body TSL

SAR averaged over 1 cm ³ (1 g) of Body TSL	Condition	
SAR measured	250 mW input power	9.95 W/kg
SAR for nominal Body TSL parameters	normalized to 1W	39.9 W/kg \pm 17.0 % (k=2)

SAR averaged over 10 cm ³ (10 g) of Body TSL	condition	
SAR measured	250 mW input power	5.28 W/kg
SAR for nominal Body TSL parameters	normalized to 1W	21.1 W/kg \pm 16.5 % (k=2)

Appendix (Additional assessments outside the scope of SCS 0108)

Antenna Parameters with Head TSL

Impedance, transformed to feed point	52.4 Ω + 5.5 j Ω
Return Loss	- 24.6 dB

Antenna Parameters with Body TSL

Impedance, transformed to feed point	49.6 Ω + 7.0 j Ω
Return Loss	- 23.1 dB

General Antenna Parameters and Design

Electrical Delay (one direction)	1.197 ns
----------------------------------	----------

After long term use with 100W radiated power, only a slight warming of the dipole near the feedpoint can be measured.

The dipole is made of standard semirigid coaxial cable. The center conductor of the feeding line is directly connected to the second arm of the dipole. The antenna is therefore short-circuited for DC-signals. On some of the dipoles, small end caps are added to the dipole arms in order to improve matching when loaded according to the position as explained in the "Measurement Conditions" paragraph. The SAR data are not affected by this change. The overall dipole length is still according to the Standard.

No excessive force must be applied to the dipole arms, because they might bend or the soldered connections near the feedpoint may be damaged.

Additional EUT Data

Manufactured by	SPEAG
Manufactured on	March 11, 2011

DASY5 Validation Report for Head TSL

Date: 15.07.2016

Test Laboratory: SPEAG, Zurich, Switzerland

DUT: Dipole 1900 MHz; Type: D1900V2; Serial: D1900V2 - SN:5d149

Communication System: UID 0 - CW; Frequency: 1900 MHz

Medium parameters used: $f = 1900$ MHz; $\sigma = 1.38$ S/m; $\epsilon_r = 39.8$; $\rho = 1000$ kg/m³

Phantom section: Flat Section

Measurement Standard: DASY5 (IEEE/IEC/ANSI C63.19-2011)

DASY52 Configuration:

- Probe: EX3DV4 - SN7349; ConvF(7.99, 7.99, 7.99); Calibrated: 15.06.2016;
- Sensor-Surface: 1.4mm (Mechanical Surface Detection)
- Electronics: DAE4 Sn601; Calibrated: 30.12.2015
- Phantom: Flat Phantom 5.0 (front); Type: QD000P50AA; Serial: 1001
- DASY52 52.8.8(1258); SEMCAD X 14.6.10(7372)

Dipole Calibration for Head Tissue/Pin=250 mW, d=10mm/Zoom Scan (7x7x7)/Cube 0:

Measurement grid: dx=5mm, dy=5mm, dz=5mm

Reference Value = 107.5 V/m; Power Drift = -0.02 dB

Peak SAR (extrapolated) = 18.7 W/kg

SAR(1 g) = 9.96 W/kg; SAR(10 g) = 5.23 W/kg

Maximum value of SAR (measured) = 15.5 W/kg

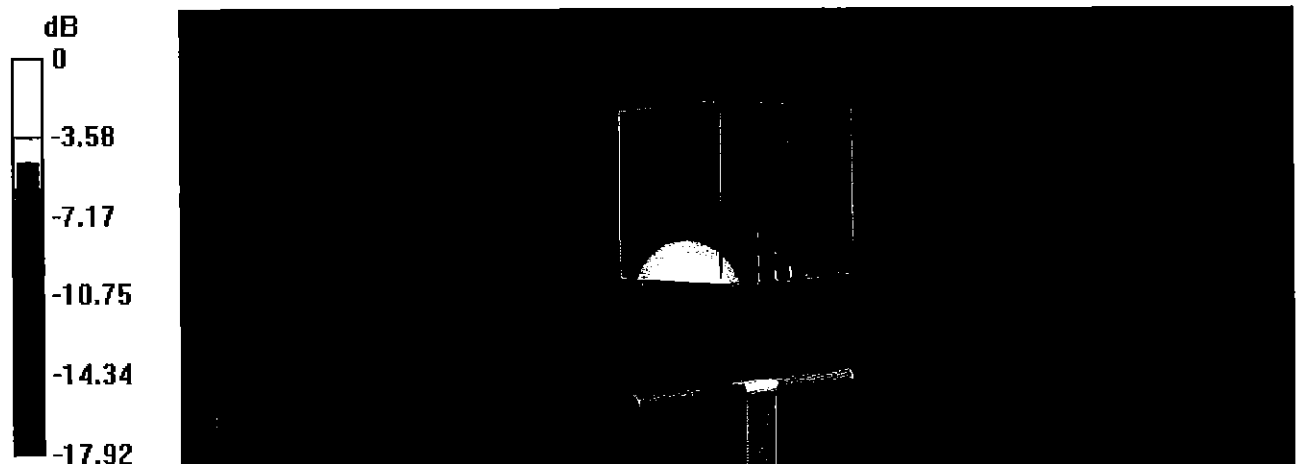

0 dB = 15.5 W/kg = 11.90 dBW/kg

Impedance Measurement Plot for Head TSL

15 Jul 2016 14:30:53

[CH1] S11 1 U FS 1: 52.393 Ω 5.5488 Ω 454.80 μ H 1 900.000 000 MHz

*
De1
CA
Avg
16
H1d

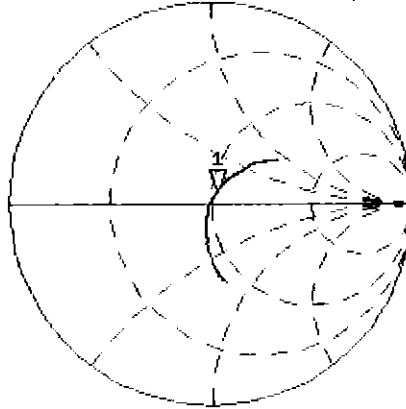

CH2 S11 LOG 5 dB/REF -20 dB 1:-24.579 dB 1 900.000 000 MHz

CA
H1d

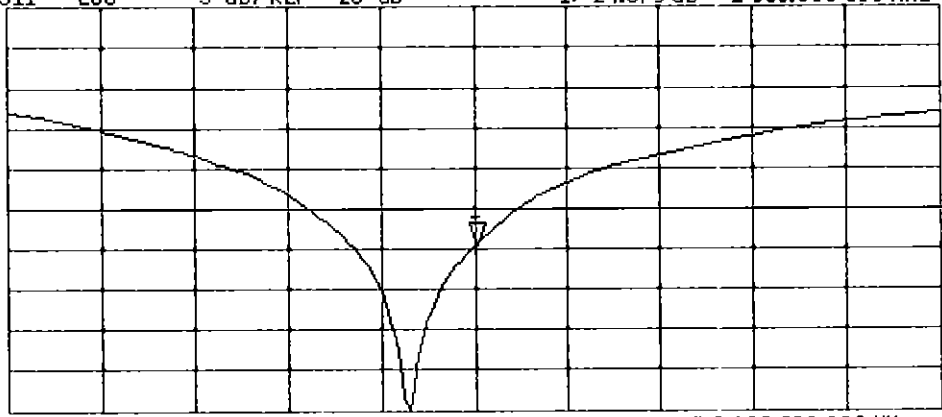

START 1 700.000 000 MHz

STOP 2 100.000 000 MHz

DASY5 Validation Report for Body TSL

Date: 13.07.2016

Test Laboratory: SPEAG, Zurich, Switzerland

DUT: Dipole 1900 MHz D1900V2; Type: D1900V2; Serial: D1900V2 - SN:5d149

Communication System: UID 0 - CW; Frequency: 1900 MHz

Medium parameters used: $f = 1900$ MHz; $\sigma = 1.51$ S/m; $\epsilon_r = 52.7$; $\rho = 1000$ kg/m³

Phantom section: Flat Section

Measurement Standard: DASY5 (IEEE/IEC/ANSI C63.19-2011)

DASY52 Configuration:

- Probe: EX3DV4 - SN7349; ConvF(8.03, 8.03, 8.03); Calibrated: 15.06.2016;
- Sensor-Surface: 1.4mm (Mechanical Surface Detection)
- Electronics: DAE4 Sn601; Calibrated: 30.12.2015
- Phantom: Flat Phantom 5.0 (back); Type: QD000P50AA; Serial: 1002
- DASY52 52.8.8(1222); SEMCAD X 14.6.10(7372)

Dipole Calibration for Body Tissue/Pin=250 mW, d=10mm/Zoom Scan (7x7x7)/Cube 0:

Measurement grid: dx=5mm, dy=5mm, dz=5mm

Reference Value = 103.9 V/m; Power Drift = 0.00 dB

Peak SAR (extrapolated) = 17.4 W/kg

SAR(1 g) = 9.95 W/kg; SAR(10 g) = 5.28 W/kg

Maximum value of SAR (measured) = 14.9 W/kg

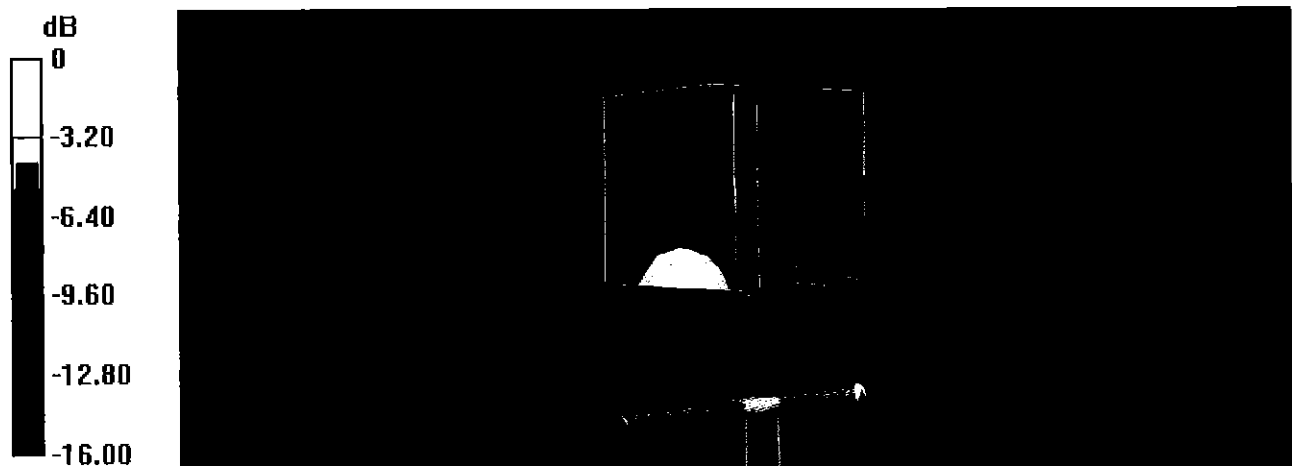

0 dB = 14.9 W/kg = 11.73 dBW/kg

Impedance Measurement Plot for Body TSL

13 Jul 2016 16:29:36

CH1 S11 1 U FS 1: 49.625 Ω 6.9922 Ω 585.71 pF 1 900.000 000 MHz

*
De1
Cor
Avg
16
H1d

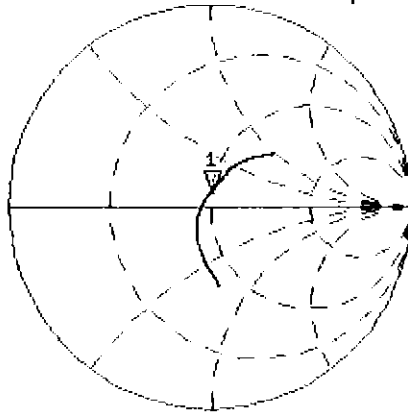

CH2 S11 LOG 5 dB/REF -20 dB 1:-23.087 dB 1 900.000 000 MHz

Cor
Avg
16
H1d

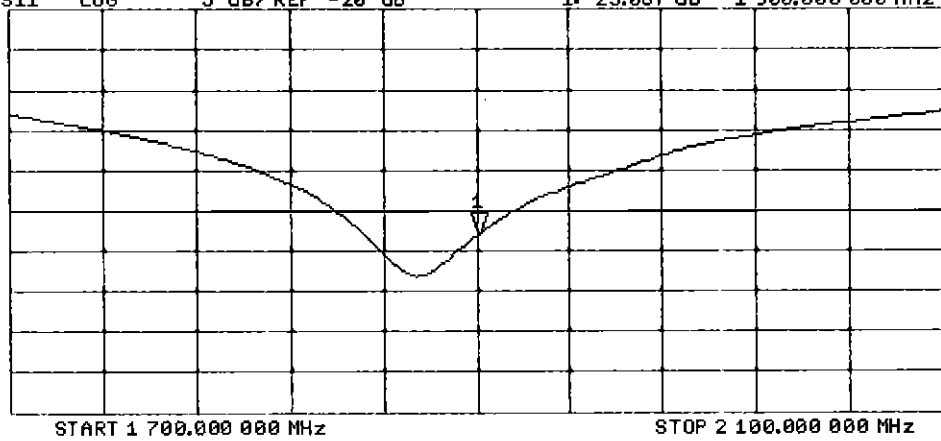



Accredited by the Swiss Accreditation Service (SAS)
The Swiss Accreditation Service is one of the signatories to the EA
Multilateral Agreement for the recognition of calibration certificates

Accreditation No.: **SCS 0108**

Client **PC Test**

Certificate No: **D2450V2-981_Jul16**

CALIBRATION CERTIFICATE

Object **D2450V2 - SN:981**

Calibration procedure(s) **QA CAL-05.v9**
Calibration procedure for dipole validation kits above 700 MHz

✓ PM
8/9/16

Calibration date: **July 25, 2016**

This calibration certificate documents the traceability to national standards, which realize the physical units of measurements (SI).
The measurements and the uncertainties with confidence probability are given on the following pages and are part of the certificate.

All calibrations have been conducted in the closed laboratory facility: environment temperature (22 ± 3)°C and humidity < 70%.

Calibration Equipment used (M&TE critical for calibration)

Primary Standards	ID #	Cal Date (Certificate No.)	Scheduled Calibration
Power meter NRP	SN: 104778	06-Apr-16 (No. 217-02288/02289)	Apr-17
Power sensor NRP-Z91	SN: 103244	06-Apr-16 (No. 217-02288)	Apr-17
Power sensor NRP-Z91	SN: 103245	06-Apr-16 (No. 217-02289)	Apr-17
Reference 20 dB Attenuator	SN: 5058 (20k)	05-Apr-16 (No. 217-02292)	Apr-17
Type-N mismatch combination	SN: 5047.2 / 06327	05-Apr-16 (No. 217-02295)	Apr-17
Reference Probe EX3DV4	SN: 7349	15-Jun-16 (No. EX3-7349_Jun16)	Jun-17
DAE4	SN: 601	30-Dec-15 (No. DAE4-601_Dec15)	Dec-16

Secondary Standards	ID #	Check Date (in house)	Scheduled Check
Power meter EPM-442A	SN: GB37480704	07-Oct-15 (No. 217-02222)	In house check: Oct-16
Power sensor HP 8481A	SN: US37292783	07-Oct-15 (No. 217-02222)	In house check: Oct-16
Power sensor HP 8481A	SN: MY41092317	07-Oct-15 (No. 217-02223)	In house check: Oct-16
RF generator R&S SMT-06	SN: 100972	15-Jun-15 (in house check Jun-15)	In house check: Oct-16
Network Analyzer HP 8753E	SN: US37390585	18-Oct-01 (in house check Oct-15)	In house check: Oct-16

Calibrated by: **Michael Weber** Name: **Michael Weber** Function: **Laboratory Technician**

Signature: *M. Weber*

Approved by: **Katja Pokovic** Name: **Katja Pokovic** Function: **Technical Manager**

Signature: *Katja Pokovic*

Issued: July 27, 2016

This calibration certificate shall not be reproduced except in full without written approval of the laboratory.



Accredited by the Swiss Accreditation Service (SAS)
The Swiss Accreditation Service is one of the signatories to the EA
Multilateral Agreement for the recognition of calibration certificates

Glossary:

TSL	tissue simulating liquid
ConvF	sensitivity in TSL / NORM x,y,z
N/A	not applicable or not measured

Calibration is Performed According to the Following Standards:

- a) IEEE Std 1528-2013, "IEEE Recommended Practice for Determining the Peak Spatial-Averaged Specific Absorption Rate (SAR) in the Human Head from Wireless Communications Devices: Measurement Techniques", June 2013
- b) IEC 62209-1, "Procedure to measure the Specific Absorption Rate (SAR) for hand-held devices used in close proximity to the ear (frequency range of 300 MHz to 3 GHz)", February 2005
- c) IEC 62209-2, "Procedure to determine the Specific Absorption Rate (SAR) for wireless communication devices used in close proximity to the human body (frequency range of 30 MHz to 6 GHz)", March 2010
- d) KDB 865664, "SAR Measurement Requirements for 100 MHz to 6 GHz"

Additional Documentation:

- e) DASY4/5 System Handbook

Methods Applied and Interpretation of Parameters:

- *Measurement Conditions:* Further details are available from the Validation Report at the end of the certificate. All figures stated in the certificate are valid at the frequency indicated.
- *Antenna Parameters with TSL:* The dipole is mounted with the spacer to position its feed point exactly below the center marking of the flat phantom section, with the arms oriented parallel to the body axis.
- *Feed Point Impedance and Return Loss:* These parameters are measured with the dipole positioned under the liquid filled phantom. The impedance stated is transformed from the measurement at the SMA connector to the feed point. The Return Loss ensures low reflected power. No uncertainty required.
- *Electrical Delay:* One-way delay between the SMA connector and the antenna feed point. No uncertainty required.
- *SAR measured:* SAR measured at the stated antenna input power.
- *SAR normalized:* SAR as measured, normalized to an input power of 1 W at the antenna connector.
- *SAR for nominal TSL parameters:* The measured TSL parameters are used to calculate the nominal SAR result.

The reported uncertainty of measurement is stated as the standard uncertainty of measurement multiplied by the coverage factor $k=2$, which for a normal distribution corresponds to a coverage probability of approximately 95%.

Measurement Conditions

DASY system configuration, as far as not given on page 1.

DASY Version	DASY5	V52.8.8
Extrapolation	Advanced Extrapolation	
Phantom	Modular Flat Phantom	
Distance Dipole Center - TSL	10 mm	with Spacer
Zoom Scan Resolution	dx, dy, dz = 5 mm	
Frequency	2450 MHz \pm 1 MHz	

Head TSL parameters

The following parameters and calculations were applied.

	Temperature	Permittivity	Conductivity
Nominal Head TSL parameters	22.0 °C	39.2	1.80 mho/m
Measured Head TSL parameters	(22.0 \pm 0.2) °C	38.0 \pm 6 %	1.86 mho/m \pm 6 %
Head TSL temperature change during test	< 0.5 °C	----	----

SAR result with Head TSL

SAR averaged over 1 cm ³ (1 g) of Head TSL	Condition	
SAR measured	250 mW input power	13.5 W/kg
SAR for nominal Head TSL parameters	normalized to 1W	52.8 W/kg \pm 17.0 % (k=2)

SAR averaged over 10 cm ³ (10 g) of Head TSL	condition	
SAR measured	250 mW input power	6.26 W/kg
SAR for nominal Head TSL parameters	normalized to 1W	24.7 W/kg \pm 16.5 % (k=2)

Body TSL parameters

The following parameters and calculations were applied.

	Temperature	Permittivity	Conductivity
Nominal Body TSL parameters	22.0 °C	52.7	1.95 mho/m
Measured Body TSL parameters	(22.0 \pm 0.2) °C	51.8 \pm 6 %	2.03 mho/m \pm 6 %
Body TSL temperature change during test	< 0.5 °C	----	----

SAR result with Body TSL

SAR averaged over 1 cm ³ (1 g) of Body TSL	Condition	
SAR measured	250 mW input power	13.0 W/kg
SAR for nominal Body TSL parameters	normalized to 1W	50.8 W/kg \pm 17.0 % (k=2)

SAR averaged over 10 cm ³ (10 g) of Body TSL	condition	
SAR measured	250 mW input power	6.04 W/kg
SAR for nominal Body TSL parameters	normalized to 1W	23.8 W/kg \pm 16.5 % (k=2)

Appendix (Additional assessments outside the scope of SCS 0108)

Antenna Parameters with Head TSL

Impedance, transformed to feed point	53.2 Ω + 3.4 j Ω
Return Loss	- 26.9 dB

Antenna Parameters with Body TSL

Impedance, transformed to feed point	50.2 Ω + 4.5 j Ω
Return Loss	- 27.0 dB

General Antenna Parameters and Design

Electrical Delay (one direction)	1.162 ns
----------------------------------	----------

After long term use with 100W radiated power, only a slight warming of the dipole near the feedpoint can be measured.

The dipole is made of standard semirigid coaxial cable. The center conductor of the feeding line is directly connected to the second arm of the dipole. The antenna is therefore short-circuited for DC-signals. On some of the dipoles, small end caps are added to the dipole arms in order to improve matching when loaded according to the position as explained in the "Measurement Conditions" paragraph. The SAR data are not affected by this change. The overall dipole length is still according to the Standard.

No excessive force must be applied to the dipole arms, because they might bend or the soldered connections near the feedpoint may be damaged.

Additional EUT Data

Manufactured by	SPEAG
Manufactured on	December 30, 2014

DASY5 Validation Report for Head TSL

Date: 13.07.2016

Test Laboratory: SPEAG, Zurich, Switzerland

DUT: Dipole 2450 MHz D2450V2; Type: D2450V2; Serial: D2450V2 - SN:981

Communication System: UID 0 - CW; Frequency: 2450 MHz

Medium parameters used: $f = 2450$ MHz; $\sigma = 1.86$ S/m; $\epsilon_r = 38$; $\rho = 1000$ kg/m³

Phantom section: Flat Section

Measurement Standard: DASY5 (IEEE/IEC/ANSI C63.19-2011)

DASY52 Configuration:

- Probe: EX3DV4 - SN7349; ConvF(7.72, 7.72, 7.72); Calibrated: 15.06.2016;
- Sensor-Surface: 1.4mm (Mechanical Surface Detection)
- Electronics: DAE4 Sn601; Calibrated: 30.12.2015
- Phantom: Flat Phantom 5.0 (front); Type: QD000P50AA; Serial: 1001
- DASY52 52.8.8(1258); SEMCAD X 14.6.10(7372)

Dipole Calibration for Head Tissue/Pin=250 mW, d=10mm/Zoom Scan (7x7x7)/Cube 0:

Measurement grid: dx=5mm, dy=5mm, dz=5mm

Reference Value = 115.8 V/m; Power Drift = 0.02 dB

Peak SAR (extrapolated) = 27.4 W/kg

SAR(1 g) = 13.5 W/kg; SAR(10 g) = 6.26 W/kg

Maximum value of SAR (measured) = 22.5 W/kg

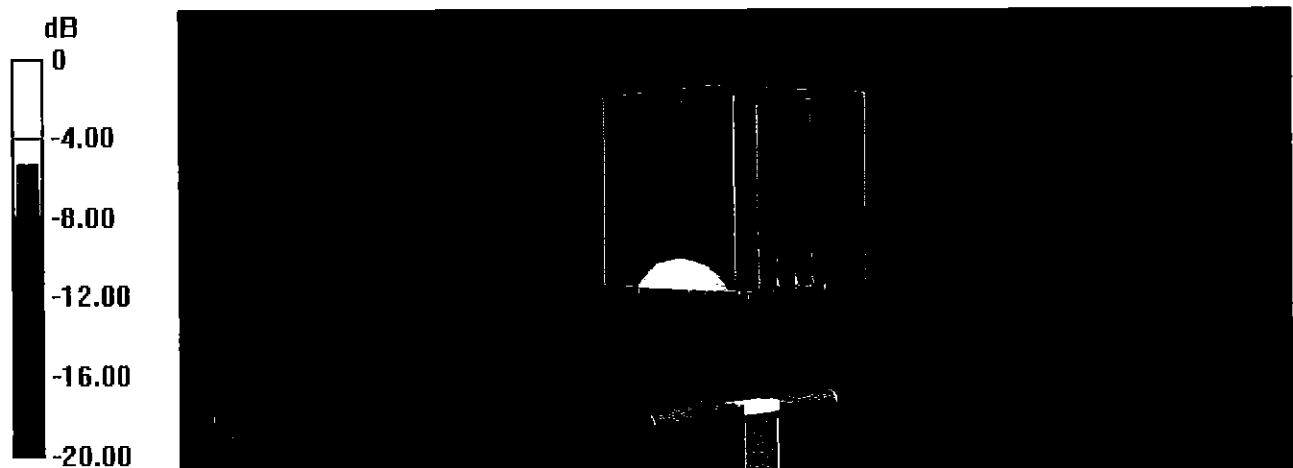

0 dB = 22.5 W/kg = 13.52 dBW/kg

Impedance Measurement Plot for Head TSL

13 Jul 2016 12:53:29

CH1 S11 1 U FS 3: 53.234 Ω 3.3633 Ω 218.48 μH 2 450.000 000 MHz

*
De l
CA
Avg
16
H1 d

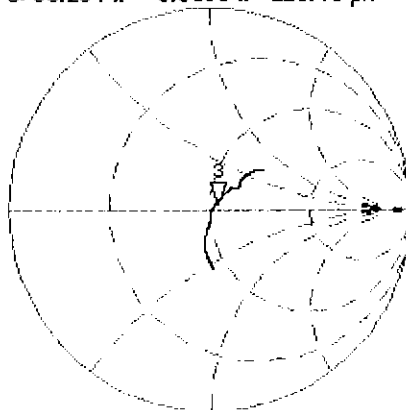

CH2 S11 LOG 5 dB/REF -20 dB 3:-26.900 dB 2 450.000 000 MHz

CA
Avg
16
H1 d

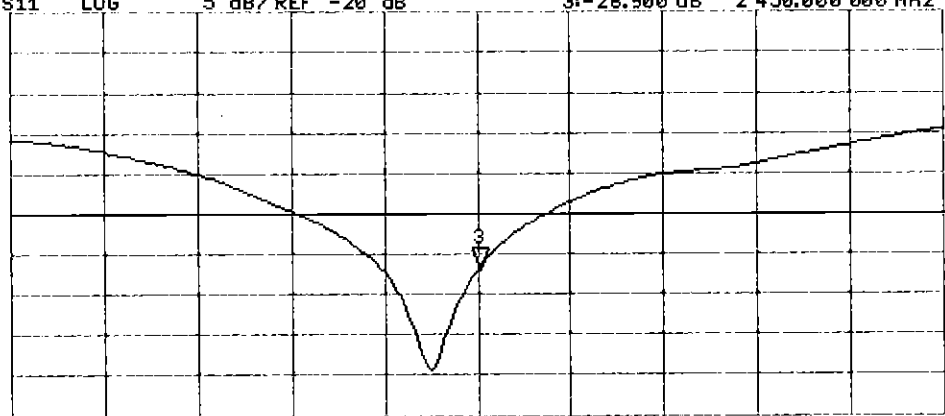

START 2 250.000 000 MHz

STOP 2 650.000 000 MHz

DASY5 Validation Report for Body TSL

Date: 25.07.2016

Test Laboratory: SPEAG, Zurich, Switzerland

DUT: Dipole 2450 MHz D2450V2; Type: D2450V2; Serial: D2450V2 - SN:981

Communication System: UID 0 - CW; Frequency: 2450 MHz

Medium parameters used: $f = 2450 \text{ MHz}$; $\sigma = 2.03 \text{ S/m}$; $\epsilon_r = 51.8$; $\rho = 1000 \text{ kg/m}^3$

Phantom section: Flat Section

Measurement Standard: DASY5 (IEEE/IEC/ANSI C63.19-2011)

DASY52 Configuration:

- Probe: EX3DV4 - SN7349; ConvF(7.79, 7.79, 7.79); Calibrated: 15.06.2016;
- Sensor-Surface: 1.4mm (Mechanical Surface Detection)
- Electronics: DAE4 Sn601; Calibrated: 30.12.2015
- Phantom: Flat Phantom 5.0 (back); Type: QD000P50AA; Serial: 1002
- DASY52 52.8.8(1258); SEMCAD X 14.6.10(7372)

Dipole Calibration for Body Tissue/Pin=250 mW, d=10mm/Zoom Scan (7x7x7)/Cube 0:

Measurement grid: dx=5mm, dy=5mm, dz=5mm

Reference Value = 107.1 V/m; Power Drift = -0.02 dB

Peak SAR (extrapolated) = 26.0 W/kg

SAR(1 g) = 13 W/kg; SAR(10 g) = 6.04 W/kg

Maximum value of SAR (measured) = 21.4 W/kg

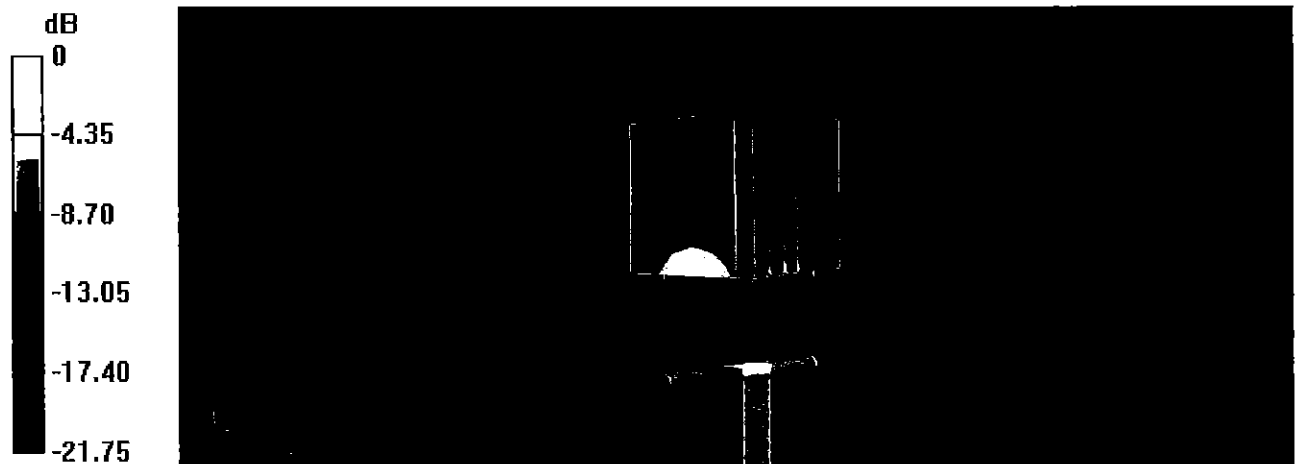

0 dB = 21.4 W/kg = 13.30 dBW/kg

Impedance Measurement Plot for Body TSL

25 Jul 2016 10:03:11

CH1 S11 1 U FS 1: 50.184 Ω 4.4980 Ω 292.20 pF 2 450.000 000 MHz

*
De1
Ca
Avg
16
H1 d

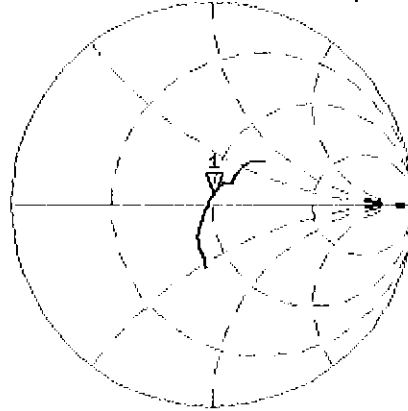

CH2 S11 LOG 5 dB/ REF -20 dB 1: -26.957 dB 2 450.000 000 MHz

Ca
H1 d

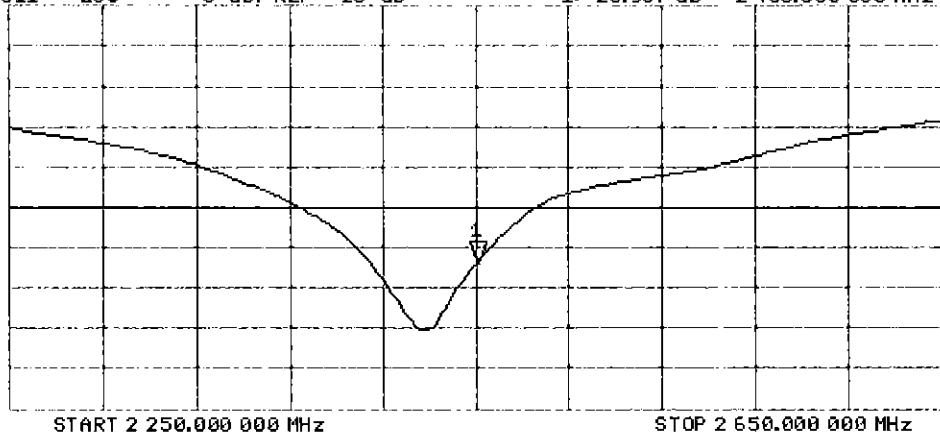

**Calibration Laboratory of
Schmid & Partner
Engineering AG**
Zeughausstrasse 43, 8004 Zurich, Switzerland



S Schweizerischer Kalibrierdienst
C Service suisse d'étalonnage
S Servizio svizzero di taratura
S Swiss Calibration Service

Accredited by the Swiss Accreditation Service (SAS)
The Swiss Accreditation Service is one of the signatories to the EA
Multilateral Agreement for the recognition of calibration certificates

Accreditation No.: **SCS 0108**

Client **PC Test**

Certificate No: **ES3-3287_Sep16**

CALIBRATION CERTIFICATE

Object: **ES3DV3 - SN:3287**

Calibration procedure(s): **QA CAL-01.v9, QA CAL-23.v5, QA CAL-25.v6**
Calibration procedure for dosimetric E-field probes

Calibration date: **September 19, 2016**

BNV
09-28-2016

This calibration certificate documents the traceability to national standards, which realize the physical units of measurements (SI).
The measurements and the uncertainties with confidence probability are given on the following pages and are part of the certificate.

All calibrations have been conducted in the closed laboratory facility: environment temperature (22 ± 3)°C and humidity < 70%.

Calibration Equipment used (M&TE critical for calibration)

Primary Standards	ID	Cal Date (Certificate No.)	Scheduled Calibration
Power meter NRP	SN: 104778	06-Apr-16 (No. 217-02288/02289)	Apr-17
Power sensor NRP-Z91	SN: 103244	06-Apr-16 (No. 217-02288)	Apr-17
Power sensor NRP-Z91	SN: 103245	06-Apr-16 (No. 217-02289)	Apr-17
Reference 20 dB Attenuator	SN: S5277 (20x)	05-Apr-16 (No. 217-02293)	Apr-17
Reference Probe ES3DV2	SN: 3013	31-Dec-15 (No. ES3-3013_Dec15)	Dec-16
DAE4	SN: 660	23-Dec-15 (No. DAE4-660_Dec15)	Dec-16
Secondary Standards	ID	Check Date (in house)	Scheduled Check
Power meter E4419B	SN: GB41293874	06-Apr-16 (in house check Jun-16)	In house check: Jun-18
Power sensor E4412A	SN: MY41498087	06-Apr-16 (in house check Jun-16)	In house check: Jun-18
Power sensor E4412A	SN: 000110210	06-Apr-16 (in house check Jun-16)	In house check: Jun-18
RF generator HP 8648C	SN: US3642U01700	04-Aug-99 (in house check Jun-16)	In house check: Jun-18
Network Analyzer HP 8753E	SN: US37390585	18-Oct-01 (in house check Oct-15)	In house check: Oct-16

Calibrated by:	Name Leif Klysner	Function Laboratory Technician	Signature <i>Leif Klysner</i>
Approved by:	Name Katja Pokovic	Function Technical Manager	Signature <i>Katja Pokovic</i>

Issued: September 20, 2016

This calibration certificate shall not be reproduced except in full without written approval of the laboratory.



Accredited by the Swiss Accreditation Service (SAS)

The Swiss Accreditation Service is one of the signatories to the EA
Multilateral Agreement for the recognition of calibration certificates

Accreditation No.: **SCS 0108**

Glossary:

TSL	tissue simulating liquid
NORM _{x,y,z}	sensitivity in free space
ConvF	sensitivity in TSL / NORM _{x,y,z}
DCP	diode compression point
CF	crest factor (1/duty_cycle) of the RF signal
A, B, C, D	modulation dependent linearization parameters
Polarization φ	φ rotation around probe axis
Polarization ϑ	ϑ rotation around an axis that is in the plane normal to probe axis (at measurement center), i.e., $\vartheta = 0$ is normal to probe axis
Connector Angle	information used in DASY system to align probe sensor X to the robot coordinate system

Calibration is Performed According to the Following Standards:

- IEEE Std 1528-2013, "IEEE Recommended Practice for Determining the Peak Spatial-Averaged Specific Absorption Rate (SAR) in the Human Head from Wireless Communications Devices: Measurement Techniques", June 2013
- IEC 62209-1, "Procedure to measure the Specific Absorption Rate (SAR) for hand-held devices used in close proximity to the ear (frequency range of 300 MHz to 3 GHz)", February 2005
- IEC 62209-2, "Procedure to determine the Specific Absorption Rate (SAR) for wireless communication devices used in close proximity to the human body (frequency range of 30 MHz to 6 GHz)", March 2010
- KDB 865664, "SAR Measurement Requirements for 100 MHz to 6 GHz"

Methods Applied and Interpretation of Parameters:

- NORM_{x,y,z}**: Assessed for E-field polarization $\vartheta = 0$ ($f \leq 900$ MHz in TEM-cell; $f > 1800$ MHz: R22 waveguide). NORM_{x,y,z} are only intermediate values, i.e., the uncertainties of NORM_{x,y,z} does not affect the E^2 -field uncertainty inside TSL (see below ConvF).
- NORM(f)_{x,y,z}** = NORM_{x,y,z} * frequency_response (see Frequency Response Chart). This linearization is implemented in DASY4 software versions later than 4.2. The uncertainty of the frequency response is included in the stated uncertainty of ConvF.
- DCP_{x,y,z}**: DCP are numerical linearization parameters assessed based on the data of power sweep with CW signal (no uncertainty required). DCP does not depend on frequency nor media.
- PAR**: PAR is the Peak to Average Ratio that is not calibrated but determined based on the signal characteristics
- A_{x,y,z}; B_{x,y,z}; C_{x,y,z}; D_{x,y,z}; VR_{x,y,z}**: A, B, C, D are numerical linearization parameters assessed based on the data of power sweep for specific modulation signal. The parameters do not depend on frequency nor media. VR is the maximum calibration range expressed in RMS voltage across the diode.
- ConvF and Boundary Effect Parameters**: Assessed in flat phantom using E-field (or Temperature Transfer Standard for $f \leq 800$ MHz) and inside waveguide using analytical field distributions based on power measurements for $f > 800$ MHz. The same setups are used for assessment of the parameters applied for boundary compensation (alpha, depth) of which typical uncertainty values are given. These parameters are used in DASY4 software to improve probe accuracy close to the boundary. The sensitivity in TSL corresponds to NORM_{x,y,z} * ConvF whereby the uncertainty corresponds to that given for ConvF. A frequency dependent ConvF is used in DASY version 4.4 and higher which allows extending the validity from ± 50 MHz to ± 100 MHz.
- Spherical isotropy (3D deviation from isotropy)**: in a field of low gradients realized using a flat phantom exposed by a patch antenna.
- Sensor Offset**: The sensor offset corresponds to the offset of virtual measurement center from the probe tip (on probe axis). No tolerance required.
- Connector Angle**: The angle is assessed using the information gained by determining the NORM_x (no uncertainty required).

Probe ES3DV3

SN:3287

Manufactured: June 7, 2010
Calibrated: September 19, 2016

Calibrated for DASY/EASY Systems
(Note: non-compatible with DASY2 system!)

DASY/EASY - Parameters of Probe: ES3DV3 - SN:3287

Basic Calibration Parameters

	Sensor X	Sensor Y	Sensor Z	Unc (k=2)
Norm ($\mu\text{V}/(\text{V}/\text{m})^2$) ^A	0.87	0.98	1.00	$\pm 10.1\%$
DCP (mV) ^B	101.9	101.4	106.1	

Modulation Calibration Parameters

UID	Communication System Name		A dB	B dB $\sqrt{\mu\text{V}}$	C	D dB	VR mV	Unc ^E (k=2)
0	CW	X	0.0	0.0	1.0	0.00	198.4	$\pm 3.5\%$
		Y	0.0	0.0	1.0		189.6	
		Z	0.0	0.0	1.0		184.8	

Note: For details on UID parameters see Appendix.

Sensor Model Parameters

	C1 fF	C2 fF	α V ⁻¹	T1 ms.V ⁻²	T2 ms.V ⁻¹	T3 ms	T4 V ⁻²	T5 V ⁻¹	T6
X	65.67	459.4	34.07	29.08	2.68	5.077	2	0.308	1.009
Y	71.46	511.8	35.31	29.86	3.707	5.1	0.748	0.607	1.009
Z	50.48	357.3	34.55	27.84	2.262	5.1	1.583	0.279	1.01

The reported uncertainty of measurement is stated as the standard uncertainty of measurement multiplied by the coverage factor k=2, which for a normal distribution corresponds to a coverage probability of approximately 95%.

^A The uncertainties of Norm X,Y,Z do not affect the E²-field uncertainty inside TSL (see Pages 5 and 6).

^B Numerical linearization parameter: uncertainty not required.

^E Uncertainty is determined using the max. deviation from linear response applying rectangular distribution and is expressed for the square of the field value.

DASY/EASY - Parameters of Probe: ES3DV3 - SN:3287

Calibration Parameter Determined in Head Tissue Simulating Media

f (MHz) ^c	Relative Permittivity ^F	Conductivity (S/m) ^F	ConvF X	ConvF Y	ConvF Z	Alpha ^G	Depth ^G (mm)	Unc (k=2)
750	41.9	0.89	6.96	6.96	6.96	0.44	1.36	± 12.0 %
835	41.5	0.90	6.67	6.67	6.67	0.29	1.69	± 12.0 %
1750	40.1	1.37	5.49	5.49	5.49	0.43	1.42	± 12.0 %
1900	40.0	1.40	5.27	5.27	5.27	0.41	1.45	± 12.0 %
2300	39.5	1.67	4.86	4.86	4.86	0.61	1.28	± 12.0 %
2450	39.2	1.80	4.54	4.54	4.54	0.47	1.51	± 12.0 %
2600	39.0	1.96	4.41	4.41	4.41	0.77	1.18	± 12.0 %

^c Frequency validity above 300 MHz of ± 100 MHz only applies for DASY v4.4 and higher (see Page 2), else it is restricted to ± 50 MHz. The uncertainty is the RSS of the ConvF uncertainty at calibration frequency and the uncertainty for the indicated frequency band. Frequency validity below 300 MHz is ± 10, 25, 40, 50 and 70 MHz for ConvF assessments at 30, 64, 128, 150 and 220 MHz respectively. Above 5 GHz frequency validity can be extended to ± 110 MHz.

^F At frequencies below 3 GHz, the validity of tissue parameters (ϵ and σ) can be relaxed to ± 10% if liquid compensation formula is applied to measured SAR values. At frequencies above 3 GHz, the validity of tissue parameters (ϵ and σ) is restricted to ± 5%. The uncertainty is the RSS of the ConvF uncertainty for indicated target tissue parameters.

^G Alpha/Depth are determined during calibration. SPEAG warrants that the remaining deviation due to the boundary effect after compensation is always less than ± 1% for frequencies below 3 GHz and below ± 2% for frequencies between 3-6 GHz at any distance larger than half the probe tip diameter from the boundary.

DASY/EASY - Parameters of Probe: ES3DV3 - SN:3287

Calibration Parameter Determined in Body Tissue Simulating Media

f (MHz) ^C	Relative Permittivity ^F	Conductivity (S/m) ^F	ConvF X	ConvF Y	ConvF Z	Alpha ^G	Depth ^G (mm)	Unc (k=2)
750	55.5	0.96	6.64	6.64	6.64	0.27	1.86	± 12.0 %
835	55.2	0.97	6.55	6.55	6.55	0.50	1.37	± 12.0 %
1750	53.4	1.49	5.11	5.11	5.11	0.33	1.85	± 12.0 %
1900	53.3	1.52	4.94	4.94	4.94	0.42	1.59	± 12.0 %
2300	52.9	1.81	4.55	4.55	4.55	0.55	1.42	± 12.0 %
2450	52.7	1.95	4.35	4.35	4.35	0.80	1.09	± 12.0 %
2600	52.5	2.16	4.12	4.12	4.12	0.80	1.10	± 12.0 %

^C Frequency validity above 300 MHz of ± 100 MHz only applies for DASY v4.4 and higher (see Page 2), else it is restricted to ± 50 MHz. The uncertainty is the RSS of the ConvF uncertainty at calibration frequency and the uncertainty for the indicated frequency band. Frequency validity below 300 MHz is ± 10, 25, 40, 50 and 70 MHz for ConvF assessments at 30, 64, 128, 150 and 220 MHz respectively. Above 5 GHz frequency validity can be extended to ± 110 MHz.

^F At frequencies below 3 GHz, the validity of tissue parameters (ϵ and σ) can be relaxed to ± 10% if liquid compensation formula is applied to measured SAR values. At frequencies above 3 GHz, the validity of tissue parameters (ϵ and σ) is restricted to ± 5%. The uncertainty is the RSS of the ConvF uncertainty for indicated target tissue parameters.

^G Alpha/Depth are determined during calibration. SPEAG warrants that the remaining deviation due to the boundary effect after compensation is always less than ± 1% for frequencies below 3 GHz and below ± 2% for frequencies between 3-6 GHz at any distance larger than half the probe tip diameter from the boundary.

Frequency Response of E-Field (TEM-Cell:ifi110 EXX, Waveguide: R22)

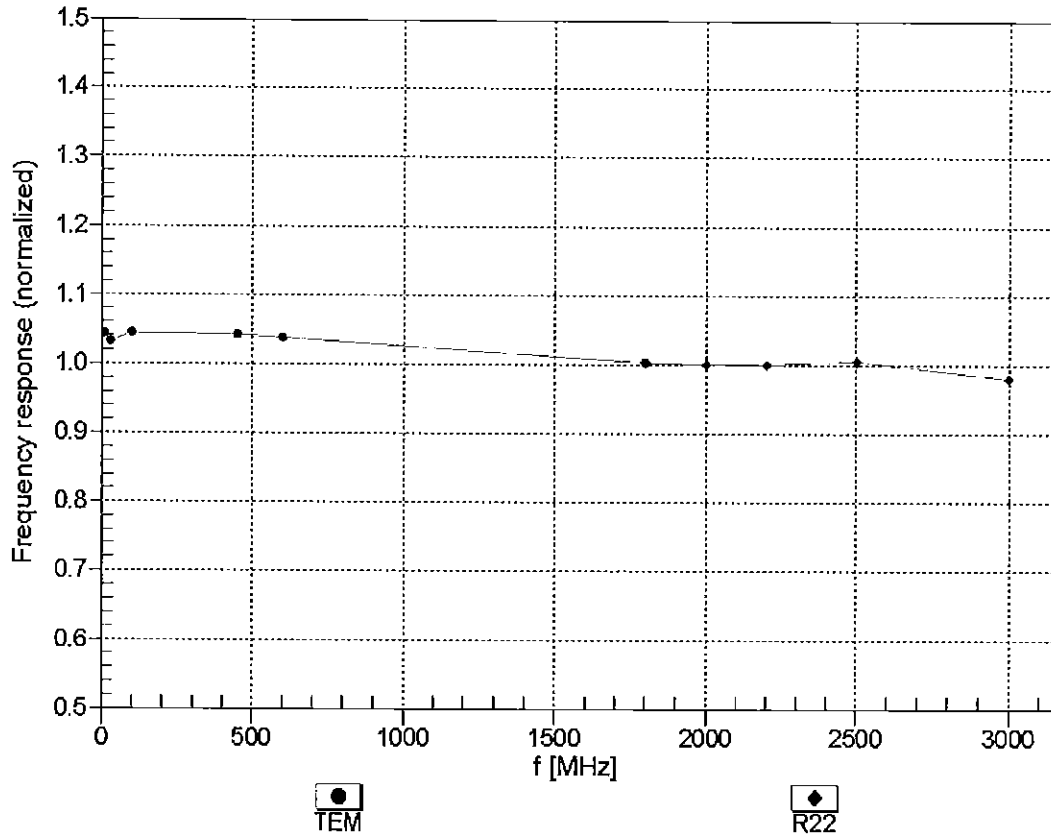

Uncertainty of Frequency Response of E-field: $\pm 6.3\%$ (k=2)

Receiving Pattern (ϕ), $\vartheta = 0^\circ$

f=600 MHz, TEM

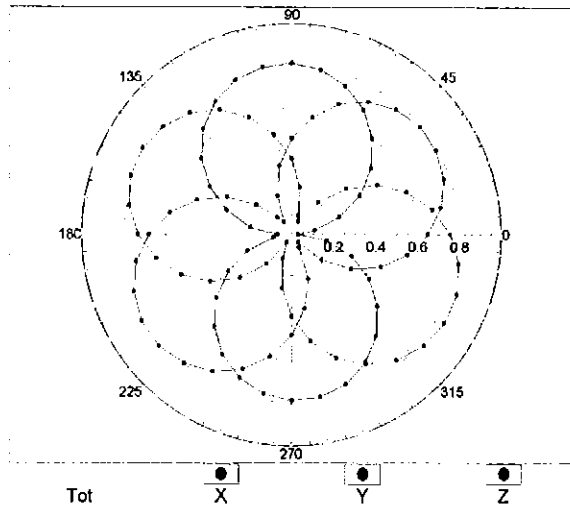

f=1800 MHz, R22

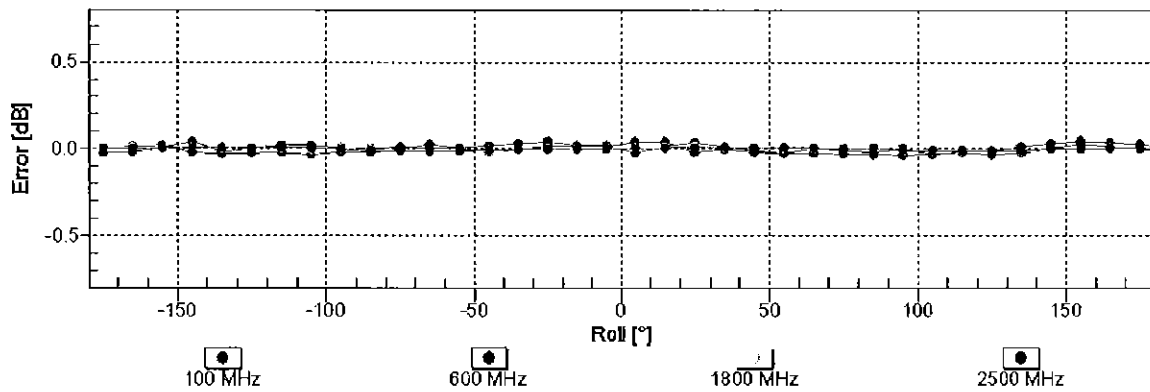
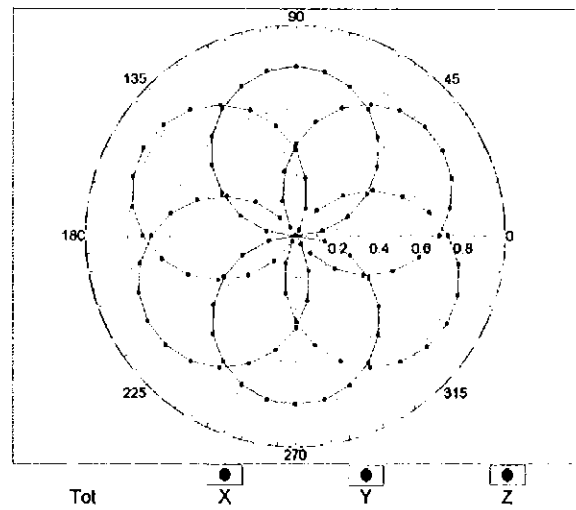

Uncertainty of Axial Isotropy Assessment: $\pm 0.5\%$ (k=2)

Dynamic Range $f(SAR_{head})$ (TEM cell , $f_{eval}= 1900$ MHz)

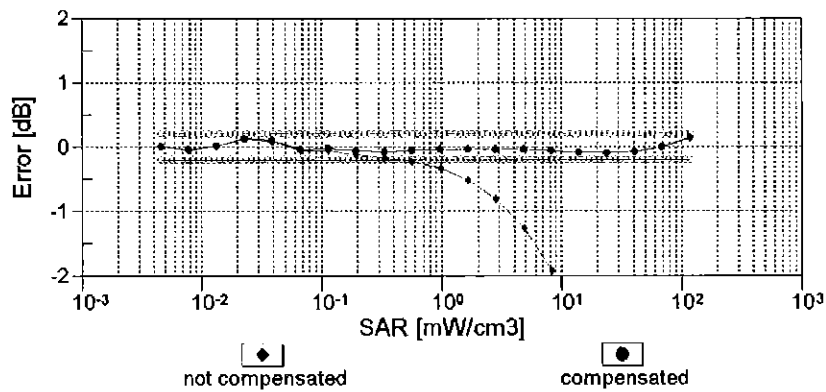
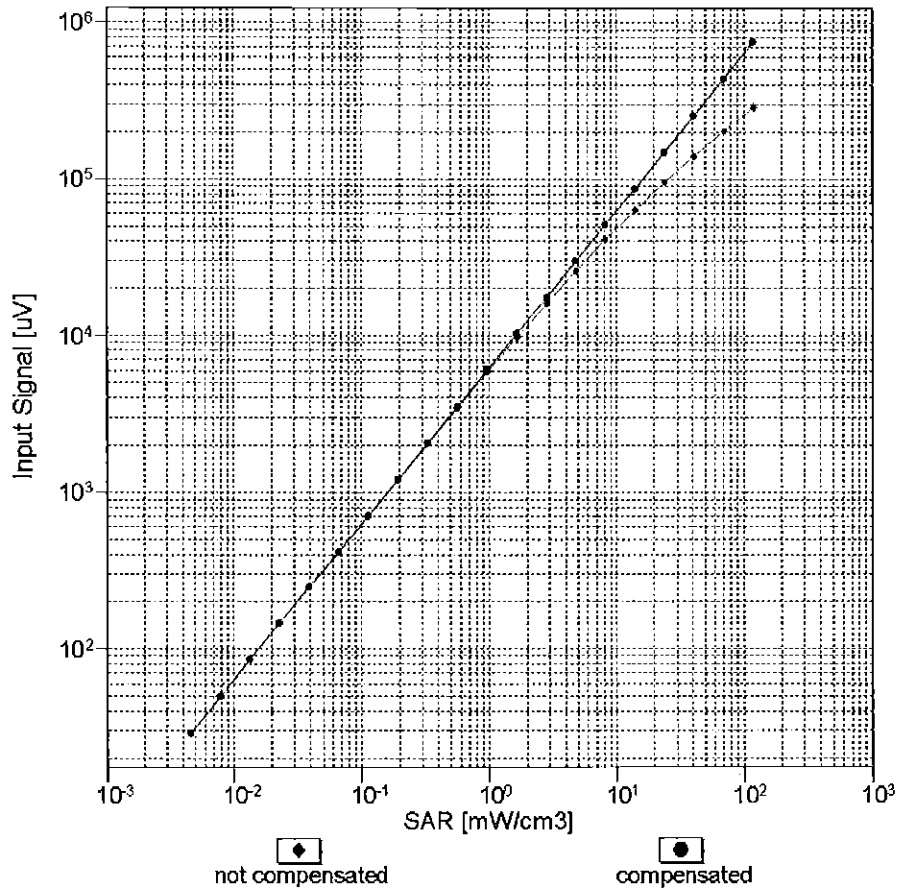

Uncertainty of Linearity Assessment: $\pm 0.6\%$ (k=2)

Conversion Factor Assessment

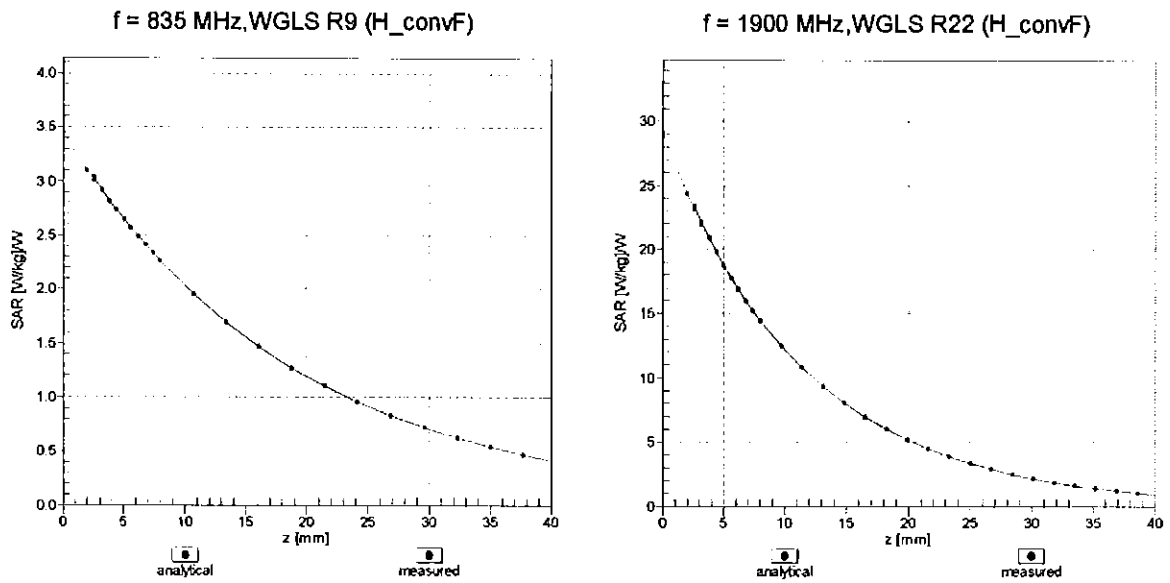

Deviation from Isotropy in Liquid Error (ϕ, ϑ), f = 900 MHz

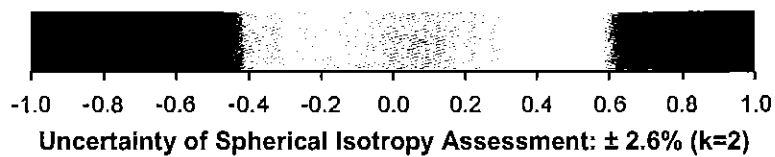
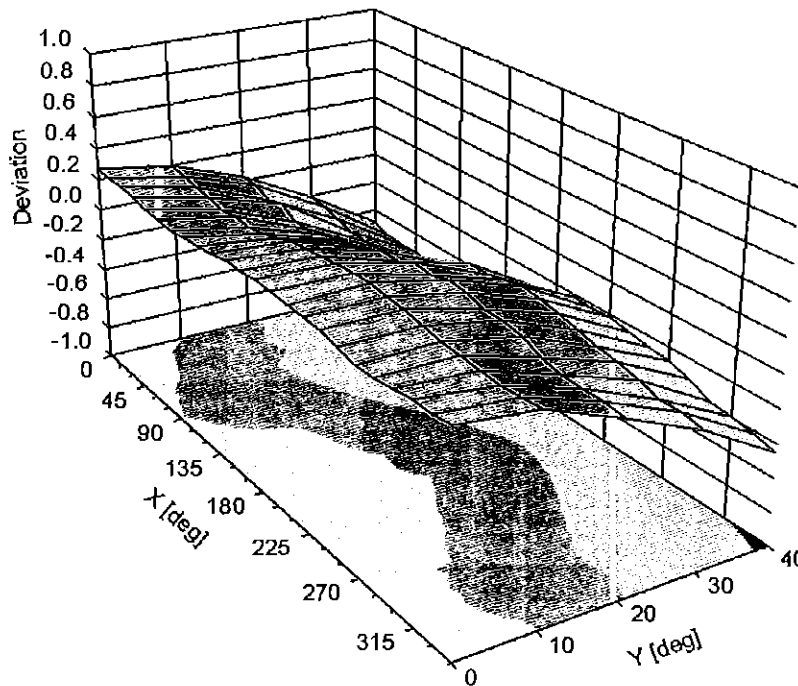

DASY/EASY - Parameters of Probe: ES3DV3 - SN:3287

Other Probe Parameters

Sensor Arrangement	Triangular
Connector Angle (°)	84.9
Mechanical Surface Detection Mode	enabled
Optical Surface Detection Mode	disabled
Probe Overall Length	337 mm
Probe Body Diameter	10 mm
Tip Length	10 mm
Tip Diameter	4 mm
Probe Tip to Sensor X Calibration Point	2 mm
Probe Tip to Sensor Y Calibration Point	2 mm
Probe Tip to Sensor Z Calibration Point	2 mm
Recommended Measurement Distance from Surface	3 mm

Appendix: Modulation Calibration Parameters

UID	Communication System Name		A dB	B dB μ V	C	D dB	VR mV	Max Unc ^E (k=2)
0	CW	X	0.00	0.00	1.00	0.00	198.4	$\pm 3.5\%$
		Y	0.00	0.00	1.00		189.6	
		Z	0.00	0.00	1.00		184.8	
10010- CAA	SAR Validation (Square, 100ms, 10ms)	X	9.57	81.27	19.66	10.00	25.0	$\pm 9.6\%$
		Y	9.48	81.17	20.59		25.0	
		Z	11.44	84.72	20.81		25.0	
10011- CAB	UMTS-FDD (WCDMA)	X	1.41	73.12	18.60	0.00	150.0	$\pm 9.6\%$
		Y	1.09	67.36	15.29		150.0	
		Z	1.04	67.24	15.12		150.0	
10012- CAB	IEEE 802.11b WiFi 2.4 GHz (DSSS, 1 Mbps)	X	1.39	66.79	17.15	0.41	150.0	$\pm 9.6\%$
		Y	1.33	64.98	15.75		150.0	
		Z	1.31	64.97	15.66		150.0	
10013- CAB	IEEE 802.11g WiFi 2.4 GHz (DSSS-OFDM, 6 Mbps)	X	5.20	67.40	17.54	1.46	150.0	$\pm 9.6\%$
		Y	5.27	67.18	17.41		150.0	
		Z	5.09	67.33	17.40		150.0	
10021- DAB	GSM-FDD (TDMA, GMSK)	X	25.12	98.64	27.15	9.39	50.0	$\pm 9.6\%$
		Y	16.05	91.61	25.96		50.0	
		Z	54.58	112.47	31.02		50.0	
10023- DAB	GPRS-FDD (TDMA, GMSK, TN 0)	X	21.90	96.28	26.48	9.57	50.0	$\pm 9.6\%$
		Y	15.04	90.31	25.57		50.0	
		Z	40.95	107.64	29.77		50.0	
10024- DAB	GPRS-FDD (TDMA, GMSK, TN 0-1)	X	100.00	118.44	30.60	6.56	60.0	$\pm 9.6\%$
		Y	56.85	112.42	30.28		60.0	
		Z	100.00	119.26	30.80		60.0	
10025- DAB	EDGE-FDD (TDMA, 8PSK, TN 0)	X	15.98	100.03	37.68	12.57	50.0	$\pm 9.6\%$
		Y	12.36	89.89	33.32		50.0	
		Z	14.92	100.13	38.33		50.0	
10026- DAB	EDGE-FDD (TDMA, 8PSK, TN 0-1)	X	19.89	102.72	35.15	9.56	60.0	$\pm 9.6\%$
		Y	15.11	94.49	32.22		60.0	
		Z	21.16	106.39	36.94		60.0	
10027- DAB	GPRS-FDD (TDMA, GMSK, TN 0-1-2)	X	100.00	117.46	29.21	4.80	80.0	$\pm 9.6\%$
		Y	100.00	119.97	30.83		80.0	
		Z	100.00	118.35	29.47		80.0	
10028- DAB	GPRS-FDD (TDMA, GMSK, TN 0-1-2-3)	X	100.00	117.97	28.63	3.55	100.0	$\pm 9.6\%$
		Y	100.00	119.91	29.91		100.0	
		Z	100.00	118.74	28.84		100.0	
10029- DAB	EDGE-FDD (TDMA, 8PSK, TN 0-1-2)	X	14.03	95.19	31.54	7.80	80.0	$\pm 9.6\%$
		Y	11.54	89.32	29.33		80.0	
		Z	13.09	95.17	31.96		80.0	
10030- CAA	IEEE 802.15.1 Bluetooth (GFSK, DH1)	X	100.00	117.04	29.36	5.30	70.0	$\pm 9.6\%$
		Y	100.00	119.78	31.12		70.0	
		Z	100.00	117.69	29.49		70.0	
10031- CAA	IEEE 802.15.1 Bluetooth (GFSK, DH3)	X	100.00	120.90	28.34	1.88	100.0	$\pm 9.6\%$
		Y	100.00	121.14	28.78		100.0	
		Z	100.00	119.84	27.78		100.0	

10032-CAA	IEEE 802.15.1 Bluetooth (GFSK, DH5)	X	100.00	128.75	30.50	1.17	100.0	± 9.6 %
		Y	100.00	125.19	29.33		100.0	
		Z	100.00	124.54	28.68		100.0	
10033-CAA	IEEE 802.15.1 Bluetooth (PI/4-DQPSK, DH1)	X	24.47	102.44	28.62	5.30	70.0	± 9.6 %
		Y	12.93	91.34	25.64		70.0	
		Z	20.22	99.06	27.27		70.0	
10034-CAA	IEEE 802.15.1 Bluetooth (PI/4-DQPSK, DH3)	X	15.75	99.73	26.60	1.88	100.0	± 9.6 %
		Y	6.06	84.29	21.90		100.0	
		Z	7.41	86.87	21.79		100.0	
10035-CAA	IEEE 802.15.1 Bluetooth (PI/4-DQPSK, DH5)	X	8.06	91.60	24.06	1.17	100.0	± 9.6 %
		Y	3.71	78.74	19.66		100.0	
		Z	4.06	80.00	19.16		100.0	
10036-CAA	IEEE 802.15.1 Bluetooth (8-DPSK, DH1)	X	31.59	106.91	29.95	5.30	70.0	± 9.6 %
		Y	14.71	93.73	26.48		70.0	
		Z	25.49	103.04	28.49		70.0	
10037-CAA	IEEE 802.15.1 Bluetooth (8-DPSK, DH3)	X	15.02	99.00	26.34	1.88	100.0	± 9.6 %
		Y	5.91	83.93	21.74		100.0	
		Z	6.95	86.01	21.48		100.0	
10038-CAA	IEEE 802.15.1 Bluetooth (8-DPSK, DH5)	X	8.64	92.97	24.58	1.17	100.0	± 9.6 %
		Y	3.82	79.37	19.97		100.0	
		Z	4.16	80.58	19.47		100.0	
10039-CAB	CDMA2000 (1xRTT, RC1)	X	3.32	80.83	20.52	0.00	150.0	± 9.6 %
		Y	1.99	71.59	16.56		150.0	
		Z	1.78	71.38	15.53		150.0	
10042-CAB	IS-54 / IS-136 FDD (TDMA/FDM, PI/4-DQPSK, Halfrate)	X	93.96	116.51	30.17	7.78	50.0	± 9.6 %
		Y	28.36	100.31	27.04		50.0	
		Z	100.00	118.01	30.46		50.0	
10044-CAA	IS-91/EIA/TIA-553 FDD (FDMA, FM)	X	0.00	110.81	0.68	0.00	150.0	± 9.6 %
		Y	0.00	94.68	0.92		150.0	
		Z	0.01	95.27	0.89		150.0	
10048-CAA	DECT (TDD, TDMA/FDM, GFSK, Full Slot, 24)	X	12.13	84.40	24.33	13.80	25.0	± 9.6 %
		Y	11.03	81.88	24.36		25.0	
		Z	15.47	90.17	26.32		25.0	
10049-CAA	DECT (TDD, TDMA/FDM, GFSK, Double Slot, 12)	X	14.56	88.92	24.53	10.79	40.0	± 9.6 %
		Y	12.34	85.94	24.48		40.0	
		Z	20.46	95.78	26.73		40.0	
10056-CAA	UMTS-TDD (TD-SCDMA, 1.28 Mcps)	X	13.90	88.80	25.15	9.03	50.0	± 9.6 %
		Y	11.60	84.93	24.34		50.0	
		Z	15.96	92.01	26.12		50.0	
10058-DAB	EDGE-FDD (TDMA, 8PSK, TN 0-1-2-3)	X	10.54	89.79	28.95	6.55	100.0	± 9.6 %
		Y	9.17	85.43	27.21		100.0	
		Z	9.28	88.15	28.66		100.0	
10059-CAB	IEEE 802.11b WiFi 2.4 GHz (DSSS, 2 Mbps)	X	1.62	69.54	18.42	0.61	110.0	± 9.6 %
		Y	1.52	67.09	16.78		110.0	
		Z	1.47	67.00	16.67		110.0	
10060-CAB	IEEE 802.11b WiFi 2.4 GHz (DSSS, 5.5 Mbps)	X	100.00	133.57	34.76	1.30	110.0	± 9.6 %
		Y	47.37	119.92	31.34		110.0	
		Z	100.00	131.70	33.88		110.0	

10061-CAB	IEEE 802.11b WiFi 2.4 GHz (DSSS, 11 Mbps)	X	24.29	111.37	31.49	2.04	110.0	± 9.6 %
		Y	7.57	90.21	25.12		110.0	
		Z	8.96	94.42	26.47		110.0	
10062-CAB	IEEE 802.11a/h WiFi 5 GHz (OFDM, 6 Mbps)	X	4.94	67.26	16.92	0.49	100.0	± 9.6 %
		Y	4.99	66.94	16.70		100.0	
		Z	4.80	67.06	16.67		100.0	
10063-CAB	IEEE 802.11a/h WiFi 5 GHz (OFDM, 9 Mbps)	X	4.98	67.42	17.05	0.72	100.0	± 9.6 %
		Y	5.03	67.12	16.85		100.0	
		Z	4.84	67.22	16.80		100.0	
10064-CAB	IEEE 802.11a/h WiFi 5 GHz (OFDM, 12 Mbps)	X	5.33	67.75	17.30	0.86	100.0	± 9.6 %
		Y	5.40	67.50	17.13		100.0	
		Z	5.14	67.52	17.06		100.0	
10065-CAB	IEEE 802.11a/h WiFi 5 GHz (OFDM, 18 Mbps)	X	5.22	67.77	17.45	1.21	100.0	± 9.6 %
		Y	5.30	67.55	17.30		100.0	
		Z	5.05	67.55	17.23		100.0	
10066-CAB	IEEE 802.11a/h WiFi 5 GHz (OFDM, 24 Mbps)	X	5.28	67.89	17.67	1.46	100.0	± 9.6 %
		Y	5.37	67.69	17.54		100.0	
		Z	5.11	67.69	17.47		100.0	
10067-CAB	IEEE 802.11a/h WiFi 5 GHz (OFDM, 36 Mbps)	X	5.58	67.96	18.07	2.04	100.0	± 9.6 %
		Y	5.70	67.83	17.99		100.0	
		Z	5.44	67.94	17.97		100.0	
10068-CAB	IEEE 802.11a/h WiFi 5 GHz (OFDM, 48 Mbps)	X	5.73	68.36	18.44	2.55	100.0	± 9.6 %
		Y	5.86	68.26	18.38		100.0	
		Z	5.56	68.20	18.31		100.0	
10069-CAB	IEEE 802.11a/h WiFi 5 GHz (OFDM, 54 Mbps)	X	5.80	68.22	18.58	2.67	100.0	± 9.6 %
		Y	5.93	68.12	18.53		100.0	
		Z	5.64	68.21	18.51		100.0	
10071-CAB	IEEE 802.11g WiFi 2.4 GHz (DSSS/OFDM, 9 Mbps)	X	5.34	67.61	17.91	1.99	100.0	± 9.6 %
		Y	5.43	67.44	17.80		100.0	
		Z	5.23	67.57	17.79		100.0	
10072-CAB	IEEE 802.11g WiFi 2.4 GHz (DSSS/OFDM, 12 Mbps)	X	5.41	68.20	18.23	2.30	100.0	± 9.6 %
		Y	5.52	68.04	18.13		100.0	
		Z	5.28	68.10	18.11		100.0	
10073-CAB	IEEE 802.11g WiFi 2.4 GHz (DSSS/OFDM, 18 Mbps)	X	5.54	68.52	18.63	2.83	100.0	± 9.6 %
		Y	5.67	68.41	18.56		100.0	
		Z	5.42	68.46	18.55		100.0	
10074-CAB	IEEE 802.11g WiFi 2.4 GHz (DSSS/OFDM, 24 Mbps)	X	5.57	68.60	18.89	3.30	100.0	± 9.6 %
		Y	5.71	68.53	18.84		100.0	
		Z	5.46	68.55	18.80		100.0	
10075-CAB	IEEE 802.11g WiFi 2.4 GHz (DSSS/OFDM, 36 Mbps)	X	5.74	69.13	19.40	3.82	90.0	± 9.6 %
		Y	5.91	69.12	19.39		90.0	
		Z	5.60	68.97	19.28		90.0	
10076-CAB	IEEE 802.11g WiFi 2.4 GHz (DSSS/OFDM, 48 Mbps)	X	5.73	68.87	19.48	4.15	90.0	± 9.6 %
		Y	5.91	68.89	19.48		90.0	
		Z	5.64	68.84	19.44		90.0	
10077-CAB	IEEE 802.11g WiFi 2.4 GHz (DSSS/OFDM, 54 Mbps)	X	5.76	68.96	19.58	4.30	90.0	± 9.6 %
		Y	5.95	68.98	19.59		90.0	
		Z	5.68	68.95	19.55		90.0	

10081-CAB	CDMA2000 (1xRTT, RC3)	X	1.45	73.74	17.54	0.00	150.0	± 9.6 %
		Y	1.01	66.70	13.93		150.0	
		Z	0.86	65.95	12.65		150.0	
10082-CAB	IS-54 / IS-136 FDD (TDMA/FDM, PI/4-DQPSK, Fullrate)	X	2.22	64.23	9.03	4.77	80.0	± 9.6 %
		Y	2.60	65.39	10.25		80.0	
		Z	2.07	64.06	8.86		80.0	
10090-DAB	GPRS-FDD (TDMA, GMSK, TN 0-4)	X	100.00	118.52	30.65	6.56	60.0	± 9.6 %
		Y	54.54	111.83	30.17		60.0	
		Z	100.00	119.33	30.85		60.0	
10097-CAB	UMTS-FDD (HSDPA)	X	2.07	69.87	17.29	0.00	150.0	± 9.6 %
		Y	1.87	67.25	15.70		150.0	
		Z	1.83	67.53	15.55		150.0	
10098-CAB	UMTS-FDD (HSUPA, Subtest 2)	X	2.03	69.88	17.28	0.00	150.0	± 9.6 %
		Y	1.83	67.20	15.65		150.0	
		Z	1.80	67.49	15.52		150.0	
10099-DAB	EDGE-FDD (TDMA, 8PSK, TN 0-4)	X	19.79	102.55	35.10	9.56	60.0	± 9.6 %
		Y	15.06	94.38	32.19		60.0	
		Z	21.07	106.24	36.89		60.0	
10100-CAB	LTE-FDD (SC-FDMA, 100% RB, 20 MHz, QPSK)	X	3.71	73.15	18.05	0.00	150.0	± 9.6 %
		Y	3.34	70.68	16.71		150.0	
		Z	3.15	70.31	16.60		150.0	
10101-CAB	LTE-FDD (SC-FDMA, 100% RB, 20 MHz, 16-QAM)	X	3.53	68.94	16.73	0.00	150.0	± 9.6 %
		Y	3.44	67.88	16.03		150.0	
		Z	3.28	67.66	15.91		150.0	
10102-CAB	LTE-FDD (SC-FDMA, 100% RB, 20 MHz, 64-QAM)	X	3.62	68.78	16.77	0.00	150.0	± 9.6 %
		Y	3.55	67.81	16.12		150.0	
		Z	3.38	67.61	16.00		150.0	
10103-CAB	LTE-TDD (SC-FDMA, 100% RB, 20 MHz, QPSK)	X	9.03	78.84	21.45	3.98	65.0	± 9.6 %
		Y	8.52	77.08	20.81		65.0	
		Z	8.79	79.04	21.64		65.0	
10104-CAB	LTE-TDD (SC-FDMA, 100% RB, 20 MHz, 16-QAM)	X	8.83	77.31	21.70	3.98	65.0	± 9.6 %
		Y	8.68	76.21	21.28		65.0	
		Z	8.45	77.10	21.68		65.0	
10105-CAB	LTE-TDD (SC-FDMA, 100% RB, 20 MHz, 64-QAM)	X	8.12	75.63	21.27	3.98	65.0	± 9.6 %
		Y	7.58	73.53	20.37		65.0	
		Z	7.68	75.16	21.11		65.0	
10108-CAC	LTE-FDD (SC-FDMA, 100% RB, 10 MHz, QPSK)	X	3.26	72.24	17.88	0.00	150.0	± 9.6 %
		Y	2.97	69.86	16.52		150.0	
		Z	2.76	69.54	16.43		150.0	
10109-CAC	LTE-FDD (SC-FDMA, 100% RB, 10 MHz, 16-QAM)	X	3.21	68.83	16.74	0.00	150.0	± 9.6 %
		Y	3.12	67.65	15.97		150.0	
		Z	2.93	67.47	15.80		150.0	
10110-CAC	LTE-FDD (SC-FDMA, 100% RB, 5 MHz, QPSK)	X	2.68	71.31	17.65	0.00	150.0	± 9.6 %
		Y	2.45	68.82	16.19		150.0	
		Z	2.25	68.65	16.05		150.0	
10111-CAC	LTE-FDD (SC-FDMA, 100% RB, 5 MHz, 16-QAM)	X	2.94	69.70	17.25	0.00	150.0	± 9.6 %
		Y	2.81	68.04	16.25		150.0	
		Z	2.63	68.09	16.01		150.0	

10112-CAC	LTE-FDD (SC-FDMA, 100% RB, 10 MHz, 64-QAM)	X	3.32	68.66	16.72	0.00	150.0	± 9.6 %
		Y	3.24	67.56	16.01		150.0	
		Z	3.06	67.45	15.85		150.0	
10113-CAC	LTE-FDD (SC-FDMA, 100% RB, 5 MHz, 64-QAM)	X	3.09	69.65	17.28	0.00	150.0	± 9.6 %
		Y	2.97	68.11	16.35		150.0	
		Z	2.78	68.22	16.13		150.0	
10114-CAB	IEEE 802.11n (HT Greenfield, 13.5 Mbps, BPSK)	X	5.30	67.67	16.69	0.00	150.0	± 9.6 %
		Y	5.32	67.34	16.45		150.0	
		Z	5.18	67.41	16.46		150.0	
10115-CAB	IEEE 802.11n (HT Greenfield, 81 Mbps, 16-QAM)	X	5.68	67.95	16.83	0.00	150.0	± 9.6 %
		Y	5.74	67.75	16.66		150.0	
		Z	5.49	67.60	16.57		150.0	
10116-CAB	IEEE 802.11n (HT Greenfield, 135 Mbps, 64-QAM)	X	5.43	67.93	16.74	0.00	150.0	± 9.6 %
		Y	5.45	67.58	16.50		150.0	
		Z	5.29	67.63	16.50		150.0	
10117-CAB	IEEE 802.11n (HT Mixed, 13.5 Mbps, BPSK)	X	5.31	67.69	16.73	0.00	150.0	± 9.6 %
		Y	5.33	67.35	16.48		150.0	
		Z	5.15	67.28	16.42		150.0	
10118-CAB	IEEE 802.11n (HT Mixed, 81 Mbps, 16-QAM)	X	5.73	68.05	16.89	0.00	150.0	± 9.6 %
		Y	5.76	67.71	16.65		150.0	
		Z	5.58	67.82	16.69		150.0	
10119-CAB	IEEE 802.11n (HT Mixed, 135 Mbps, 64-QAM)	X	5.40	67.88	16.73	0.00	150.0	± 9.6 %
		Y	5.42	67.54	16.49		150.0	
		Z	5.26	67.56	16.48		150.0	
10140-CAB	LTE-FDD (SC-FDMA, 100% RB, 15 MHz, 16-QAM)	X	3.67	68.77	16.68	0.00	150.0	± 9.6 %
		Y	3.60	67.81	16.05		150.0	
		Z	3.42	67.62	15.92		150.0	
10141-CAB	LTE-FDD (SC-FDMA, 100% RB, 15 MHz, 64-QAM)	X	3.79	68.75	16.79	0.00	150.0	± 9.6 %
		Y	3.72	67.84	16.19		150.0	
		Z	3.54	67.70	16.08		150.0	
10142-CAC	LTE-FDD (SC-FDMA, 100% RB, 3 MHz, QPSK)	X	2.48	71.58	17.67	0.00	150.0	± 9.6 %
		Y	2.22	68.66	16.03		150.0	
		Z	2.02	68.57	15.71		150.0	
10143-CAC	LTE-FDD (SC-FDMA, 100% RB, 3 MHz, 16-QAM)	X	2.90	70.86	17.43	0.00	150.0	± 9.6 %
		Y	2.68	68.61	16.20		150.0	
		Z	2.48	68.71	15.71		150.0	
10144-CAC	LTE-FDD (SC-FDMA, 100% RB, 3 MHz, 64-QAM)	X	2.65	68.53	15.87	0.00	150.0	± 9.6 %
		Y	2.53	66.90	14.94		150.0	
		Z	2.29	66.75	14.27		150.0	
10145-CAC	LTE-FDD (SC-FDMA, 100% RB, 1.4 MHz, QPSK)	X	2.00	71.65	16.48	0.00	150.0	± 9.6 %
		Y	1.64	67.49	14.42		150.0	
		Z	1.28	65.53	12.17		150.0	
10146-CAC	LTE-FDD (SC-FDMA, 100% RB, 1.4 MHz, 16-QAM)	X	6.65	82.42	19.81	0.00	150.0	± 9.6 %
		Y	3.51	73.00	16.51		150.0	
		Z	2.73	70.16	13.72		150.0	
10147-CAC	LTE-FDD (SC-FDMA, 100% RB, 1.4 MHz, 64-QAM)	X	11.62	90.60	22.70	0.00	150.0	± 9.6 %
		Y	4.34	76.22	18.03		150.0	
		Z	3.53	73.44	15.25		150.0	

10149-CAB	LTE-FDD (SC-FDMA, 50% RB, 20 MHz, 16-QAM)	X	3.22	68.90	16.79	0.00	150.0	± 9.6 %
		Y	3.13	67.70	16.01		150.0	
		Z	2.94	67.52	15.84		150.0	
10150-CAB	LTE-FDD (SC-FDMA, 50% RB, 20 MHz, 64-QAM)	X	3.33	68.71	16.76	0.00	150.0	± 9.6 %
		Y	3.25	67.61	16.05		150.0	
		Z	3.06	67.50	15.89		150.0	
10151-CAB	LTE-TDD (SC-FDMA, 50% RB, 20 MHz, QPSK)	X	9.59	81.08	22.43	3.98	65.0	± 9.6 %
		Y	8.87	78.87	21.64		65.0	
		Z	9.33	81.38	22.62		65.0	
10152-CAB	LTE-TDD (SC-FDMA, 50% RB, 20 MHz, 16-QAM)	X	8.50	77.58	21.63	3.98	65.0	± 9.6 %
		Y	8.30	76.31	21.16		65.0	
		Z	8.08	77.33	21.50		65.0	
10153-CAB	LTE-TDD (SC-FDMA, 50% RB, 20 MHz, 64-QAM)	X	8.85	78.28	22.25	3.98	65.0	± 9.6 %
		Y	8.62	76.95	21.75		65.0	
		Z	8.48	78.15	22.17		65.0	
10154-CAC	LTE-FDD (SC-FDMA, 50% RB, 10 MHz, QPSK)	X	2.77	71.95	18.01	0.00	150.0	± 9.6 %
		Y	2.51	69.32	16.50		150.0	
		Z	2.29	69.01	16.28		150.0	
10155-CAC	LTE-FDD (SC-FDMA, 50% RB, 10 MHz, 16-QAM)	X	2.94	69.69	17.25	0.00	150.0	± 9.6 %
		Y	2.80	68.03	16.25		150.0	
		Z	2.63	68.10	16.02		150.0	
10156-CAC	LTE-FDD (SC-FDMA, 50% RB, 5 MHz, QPSK)	X	2.40	72.31	17.91	0.00	150.0	± 9.6 %
		Y	2.09	68.89	16.05		150.0	
		Z	1.86	68.62	15.51		150.0	
10157-CAC	LTE-FDD (SC-FDMA, 50% RB, 5 MHz, 16-QAM)	X	2.55	69.65	16.30	0.00	150.0	± 9.6 %
		Y	2.36	67.46	15.11		150.0	
		Z	2.12	67.25	14.30		150.0	
10158-CAC	LTE-FDD (SC-FDMA, 50% RB, 10 MHz, 64-QAM)	X	3.10	69.70	17.32	0.00	150.0	± 9.6 %
		Y	2.97	68.15	16.39		150.0	
		Z	2.78	68.27	16.17		150.0	
10159-CAC	LTE-FDD (SC-FDMA, 50% RB, 5 MHz, 64-QAM)	X	2.69	70.18	16.62	0.00	150.0	± 9.6 %
		Y	2.48	67.89	15.40		150.0	
		Z	2.22	67.66	14.56		150.0	
10160-CAB	LTE-FDD (SC-FDMA, 50% RB, 15 MHz, QPSK)	X	3.10	70.43	17.35	0.00	150.0	± 9.6 %
		Y	2.94	68.69	16.29		150.0	
		Z	2.78	68.69	16.25		150.0	
10161-CAB	LTE-FDD (SC-FDMA, 50% RB, 15 MHz, 16-QAM)	X	3.22	68.62	16.74	0.00	150.0	± 9.6 %
		Y	3.14	67.48	16.00		150.0	
		Z	2.96	67.42	15.82		150.0	
10162-CAB	LTE-FDD (SC-FDMA, 50% RB, 15 MHz, 64-QAM)	X	3.32	68.61	16.76	0.00	150.0	± 9.6 %
		Y	3.24	67.49	16.04		150.0	
		Z	3.07	67.56	15.92		150.0	
10166-CAC	LTE-FDD (SC-FDMA, 50% RB, 1.4 MHz, QPSK)	X	4.32	72.20	20.50	3.01	150.0	± 9.6 %
		Y	4.09	70.13	19.37		150.0	
		Z	3.89	71.03	19.86		150.0	
10167-CAC	LTE-FDD (SC-FDMA, 50% RB, 1.4 MHz, 16-QAM)	X	6.13	77.20	21.71	3.01	150.0	± 9.6 %
		Y	5.31	73.40	20.02		150.0	
		Z	5.17	75.28	20.82		150.0	

10168-CAC	LTE-FDD (SC-FDMA, 50% RB, 1.4 MHz, 64-QAM)	X	6.94	79.87	23.11	3.01	150.0	± 9.6 %
		Y	5.79	75.28	21.14		150.0	
		Z	5.82	77.80	22.20		150.0	
10169-CAB	LTE-FDD (SC-FDMA, 1 RB, 20 MHz, QPSK)	X	4.47	76.31	22.20	3.01	150.0	± 9.6 %
		Y	3.93	72.42	20.26		150.0	
		Z	3.45	71.87	20.27		150.0	
10170-CAB	LTE-FDD (SC-FDMA, 1 RB, 20 MHz, 16-QAM)	X	9.97	90.37	26.89	3.01	150.0	± 9.6 %
		Y	6.08	79.64	22.84		150.0	
		Z	5.69	81.07	23.66		150.0	
10171-AAB	LTE-FDD (SC-FDMA, 1 RB, 20 MHz, 64-QAM)	X	6.58	81.51	22.72	3.01	150.0	± 9.6 %
		Y	4.82	74.69	19.94		150.0	
		Z	4.39	75.54	20.48		150.0	
10172-CAB	LTE-TDD (SC-FDMA, 1 RB, 20 MHz, QPSK)	X	73.64	126.23	37.77	6.02	65.0	± 9.6 %
		Y	18.65	98.22	29.94		65.0	
		Z	50.70	122.38	37.42		65.0	
10173-CAB	LTE-TDD (SC-FDMA, 1 RB, 20 MHz, 16-QAM)	X	94.74	123.96	35.21	6.02	65.0	± 9.6 %
		Y	22.61	98.04	28.47		65.0	
		Z	96.90	127.66	36.64		65.0	
10174-CAB	LTE-TDD (SC-FDMA, 1 RB, 20 MHz, 64-QAM)	X	56.11	113.11	31.91	6.02	65.0	± 9.6 %
		Y	18.59	93.53	26.66		65.0	
		Z	65.46	118.77	33.84		65.0	
10175-CAC	LTE-FDD (SC-FDMA, 1 RB, 10 MHz, QPSK)	X	4.37	75.74	21.85	3.01	150.0	± 9.6 %
		Y	3.86	71.99	19.97		150.0	
		Z	3.41	71.52	20.02		150.0	
10176-CAC	LTE-FDD (SC-FDMA, 1 RB, 10 MHz, 16-QAM)	X	9.99	90.41	26.90	3.01	150.0	± 9.6 %
		Y	6.09	79.66	22.85		150.0	
		Z	5.70	81.10	23.67		150.0	
10177-CAE	LTE-FDD (SC-FDMA, 1 RB, 5 MHz, QPSK)	X	4.43	76.02	22.00	3.01	150.0	± 9.6 %
		Y	3.90	72.21	20.10		150.0	
		Z	3.44	71.69	20.11		150.0	
10178-CAC	LTE-FDD (SC-FDMA, 1 RB, 5 MHz, 16-QAM)	X	9.65	89.71	26.63	3.01	150.0	± 9.6 %
		Y	5.97	79.26	22.66		150.0	
		Z	5.62	80.80	23.53		150.0	
10179-CAC	LTE-FDD (SC-FDMA, 1 RB, 10 MHz, 64-QAM)	X	7.97	85.43	24.54	3.01	150.0	± 9.6 %
		Y	5.36	76.88	21.19		150.0	
		Z	4.98	78.13	21.92		150.0	
10180-CAC	LTE-FDD (SC-FDMA, 1 RB, 5 MHz, 64-QAM)	X	6.51	81.29	22.61	3.01	150.0	± 9.6 %
		Y	4.79	74.55	19.86		150.0	
		Z	4.38	75.44	20.42		150.0	
10181-CAB	LTE-FDD (SC-FDMA, 1 RB, 15 MHz, QPSK)	X	4.42	75.99	21.99	3.01	150.0	± 9.6 %
		Y	3.90	72.19	20.09		150.0	
		Z	3.43	71.67	20.11		150.0	
10182-CAB	LTE-FDD (SC-FDMA, 1 RB, 15 MHz, 16-QAM)	X	9.63	89.67	26.62	3.01	150.0	± 9.6 %
		Y	5.96	79.23	22.65		150.0	
		Z	5.61	80.77	23.51		150.0	
10183-AAA	LTE-FDD (SC-FDMA, 1 RB, 15 MHz, 64-QAM)	X	6.50	81.25	22.60	3.01	150.0	± 9.6 %
		Y	4.78	74.53	19.85		150.0	
		Z	4.37	75.41	20.41		150.0	

10184-CAC	LTE-FDD (SC-FDMA, 1 RB, 3 MHz, QPSK)	X	4.44	76.05	22.02	3.01	150.0	± 9.6 %
		Y	3.91	72.24	20.12		150.0	
		Z	3.45	71.72	20.13		150.0	
10185-CAC	LTE-FDD (SC-FDMA, 1 RB, 3 MHz, 16-QAM)	X	9.70	89.80	26.67	3.01	150.0	± 9.6 %
		Y	5.99	79.32	22.68		150.0	
		Z	5.64	80.86	23.56		150.0	
10186-AAC	LTE-FDD (SC-FDMA, 1 RB, 3 MHz, 64-QAM)	X	6.54	81.37	22.64	3.01	150.0	± 9.6 %
		Y	4.81	74.60	19.88		150.0	
		Z	4.39	75.50	20.45		150.0	
10187-CAC	LTE-FDD (SC-FDMA, 1 RB, 1.4 MHz, QPSK)	X	4.45	76.10	22.07	3.01	150.0	± 9.6 %
		Y	3.92	72.26	20.15		150.0	
		Z	3.46	71.78	20.19		150.0	
10188-CAC	LTE-FDD (SC-FDMA, 1 RB, 1.4 MHz, 16-QAM)	X	10.51	91.45	27.34	3.01	150.0	± 9.6 %
		Y	6.26	80.23	23.14		150.0	
		Z	5.89	81.76	24.00		150.0	
10189-AAC	LTE-FDD (SC-FDMA, 1 RB, 1.4 MHz, 64-QAM)	X	6.85	82.27	23.07	3.01	150.0	± 9.6 %
		Y	4.94	75.14	20.19		150.0	
		Z	4.52	76.06	20.77		150.0	
10193-CAB	IEEE 802.11n (HT Greenfield, 6.5 Mbps, BPSK)	X	4.73	67.10	16.51	0.00	150.0	± 9.6 %
		Y	4.75	66.68	16.23		150.0	
		Z	4.57	66.79	16.16		150.0	
10194-CAB	IEEE 802.11n (HT Greenfield, 39 Mbps, 16-QAM)	X	4.94	67.48	16.62	0.00	150.0	± 9.6 %
		Y	4.96	67.08	16.34		150.0	
		Z	4.75	67.11	16.28		150.0	
10195-CAB	IEEE 802.11n (HT Greenfield, 65 Mbps, 64-QAM)	X	4.98	67.48	16.62	0.00	150.0	± 9.6 %
		Y	5.00	67.07	16.34		150.0	
		Z	4.79	67.14	16.30		150.0	
10196-CAB	IEEE 802.11n (HT Mixed, 6.5 Mbps, BPSK)	X	4.76	67.21	16.55	0.00	150.0	± 9.6 %
		Y	4.78	66.80	16.27		150.0	
		Z	4.58	66.86	16.18		150.0	
10197-CAB	IEEE 802.11n (HT Mixed, 39 Mbps, 16-QAM)	X	4.96	67.50	16.63	0.00	150.0	± 9.6 %
		Y	4.98	67.09	16.35		150.0	
		Z	4.76	67.14	16.30		150.0	
10198-CAB	IEEE 802.11n (HT Mixed, 65 Mbps, 64-QAM)	X	4.99	67.50	16.63	0.00	150.0	± 9.6 %
		Y	5.01	67.09	16.35		150.0	
		Z	4.79	67.16	16.31		150.0	
10219-CAB	IEEE 802.11n (HT Mixed, 7.2 Mbps, BPSK)	X	4.71	67.23	16.53	0.00	150.0	± 9.6 %
		Y	4.73	66.82	16.24		150.0	
		Z	4.53	66.87	16.14		150.0	
10220-CAB	IEEE 802.11n (HT Mixed, 43.3 Mbps, 16-QAM)	X	4.96	67.50	16.63	0.00	150.0	± 9.6 %
		Y	4.98	67.10	16.35		150.0	
		Z	4.76	67.11	16.29		150.0	
10221-CAB	IEEE 802.11n (HT Mixed, 72.2 Mbps, 64-QAM)	X	4.99	67.43	16.62	0.00	150.0	± 9.6 %
		Y	5.01	67.03	16.34		150.0	
		Z	4.80	67.09	16.30		150.0	
10222-CAB	IEEE 802.11n (HT Mixed, 15 Mbps, BPSK)	X	5.29	67.72	16.73	0.00	150.0	± 9.6 %
		Y	5.31	67.38	16.49		150.0	
		Z	5.12	67.29	16.41		150.0	

10223-CAB	IEEE 802.11n (HT Mixed, 90 Mbps, 16-QAM)	X	5.67	68.03	16.90	0.00	150.0	± 9.6 %
		Y	5.70	67.71	16.67		150.0	
		Z	5.43	67.50	16.54		150.0	
10224-CAB	IEEE 802.11n (HT Mixed, 150 Mbps, 64-QAM)	X	5.35	67.84	16.72	0.00	150.0	± 9.6 %
		Y	5.37	67.51	16.48		150.0	
		Z	5.17	67.40	16.39		150.0	
10225-CAB	UMTS-FDD (HSPA+)	X	3.03	67.01	16.18	0.00	150.0	± 9.6 %
		Y	3.00	66.12	15.59		150.0	
		Z	2.84	66.23	15.31		150.0	
10226-CAA	LTE-TDD (SC-FDMA, 1 RB, 1.4 MHz, 16-QAM)	X	100.00	125.13	35.58	6.02	65.0	± 9.6 %
		Y	23.60	98.91	28.82		65.0	
		Z	100.00	128.43	36.91		65.0	
10227-CAA	LTE-TDD (SC-FDMA, 1 RB, 1.4 MHz, 64-QAM)	X	61.16	114.83	32.47	6.02	65.0	± 9.6 %
		Y	19.96	94.87	27.16		65.0	
		Z	73.77	120.96	34.46		65.0	
10228-CAA	LTE-TDD (SC-FDMA, 1 RB, 1.4 MHz, QPSK)	X	72.18	126.53	38.01	6.02	65.0	± 9.6 %
		Y	21.44	101.40	31.05		65.0	
		Z	53.16	123.89	37.96		65.0	
10229-CAB	LTE-TDD (SC-FDMA, 1 RB, 3 MHz, 16-QAM)	X	94.57	123.93	35.21	6.02	65.0	± 9.6 %
		Y	22.66	98.06	28.49		65.0	
		Z	96.87	127.65	36.65		65.0	
10230-CAB	LTE-TDD (SC-FDMA, 1 RB, 3 MHz, 64-QAM)	X	56.39	113.28	31.99	6.02	65.0	± 9.6 %
		Y	19.26	94.16	26.88		65.0	
		Z	66.99	119.13	33.93		65.0	
10231-CAB	LTE-TDD (SC-FDMA, 1 RB, 3 MHz, QPSK)	X	66.18	124.67	37.45	6.02	65.0	± 9.6 %
		Y	20.62	100.55	30.72		65.0	
		Z	48.89	122.07	37.41		65.0	
10232-CAB	LTE-TDD (SC-FDMA, 1 RB, 5 MHz, 16-QAM)	X	94.69	123.96	35.21	6.02	65.0	± 9.6 %
		Y	22.64	98.05	28.48		65.0	
		Z	97.00	127.68	36.66		65.0	
10233-CAB	LTE-TDD (SC-FDMA, 1 RB, 5 MHz, 64-QAM)	X	56.52	113.33	32.00	6.02	65.0	± 9.6 %
		Y	19.26	94.17	26.88		65.0	
		Z	67.07	119.16	33.94		65.0	
10234-CAB	LTE-TDD (SC-FDMA, 1 RB, 5 MHz, QPSK)	X	60.26	122.59	36.81	6.02	65.0	± 9.6 %
		Y	19.81	99.63	30.34		65.0	
		Z	45.11	120.21	36.81		65.0	
10235-CAB	LTE-TDD (SC-FDMA, 1 RB, 10 MHz, 16-QAM)	X	95.38	124.09	35.25	6.02	65.0	± 9.6 %
		Y	22.67	98.09	28.50		65.0	
		Z	97.77	127.84	36.70		65.0	
10236-CAB	LTE-TDD (SC-FDMA, 1 RB, 10 MHz, 64-QAM)	X	57.18	113.50	32.04	6.02	65.0	± 9.6 %
		Y	19.38	94.26	26.90		65.0	
		Z	68.10	119.39	33.99		65.0	
10237-CAB	LTE-TDD (SC-FDMA, 1 RB, 10 MHz, QPSK)	X	67.28	125.01	37.54	6.02	65.0	± 9.6 %
		Y	20.74	100.68	30.76		65.0	
		Z	49.59	122.38	37.49		65.0	
10238-CAB	LTE-TDD (SC-FDMA, 1 RB, 15 MHz, 16-QAM)	X	95.00	124.02	35.23	6.02	65.0	± 9.6 %
		Y	22.64	98.06	28.49		65.0	
		Z	97.19	127.73	36.66		65.0	

10239-CAB	LTE-TDD (SC-FDMA, 1 RB, 15 MHz, 64-QAM)	X	56.67	113.39	32.01	6.02	65.0	± 9.6 %
		Y	19.26	94.19	26.88		65.0	
		Z	67.13	119.19	33.94		65.0	
10240-CAB	LTE-TDD (SC-FDMA, 1 RB, 15 MHz, QPSK)	X	67.00	124.93	37.52	6.02	65.0	± 9.6 %
		Y	20.68	100.63	30.74		65.0	
		Z	49.37	122.30	37.47		65.0	
10241-CAA	LTE-TDD (SC-FDMA, 50% RB, 1.4 MHz, 16-QAM)	X	14.43	89.77	28.56	6.98	65.0	± 9.6 %
		Y	12.31	85.00	26.80		65.0	
		Z	13.89	90.56	28.94		65.0	
10242-CAA	LTE-TDD (SC-FDMA, 50% RB, 1.4 MHz, 64-QAM)	X	13.70	88.57	28.03	6.98	65.0	± 9.6 %
		Y	10.82	82.08	25.53		65.0	
		Z	13.16	89.30	28.37		65.0	
10243-CAA	LTE-TDD (SC-FDMA, 50% RB, 1.4 MHz, QPSK)	X	10.55	84.90	27.56	6.98	65.0	± 9.6 %
		Y	8.88	79.49	25.25		65.0	
		Z	9.99	85.03	27.70		65.0	
10244-CAB	LTE-TDD (SC-FDMA, 50% RB, 3 MHz, 16-QAM)	X	11.43	83.67	22.47	3.98	65.0	± 9.6 %
		Y	9.78	80.48	21.64		65.0	
		Z	9.76	81.22	20.90		65.0	
10245-CAB	LTE-TDD (SC-FDMA, 50% RB, 3 MHz, 64-QAM)	X	11.21	83.09	22.22	3.98	65.0	± 9.6 %
		Y	9.71	80.13	21.47		65.0	
		Z	9.48	80.50	20.58		65.0	
10246-CAB	LTE-TDD (SC-FDMA, 50% RB, 3 MHz, QPSK)	X	10.58	85.22	23.00	3.98	65.0	± 9.6 %
		Y	8.86	81.57	21.94		65.0	
		Z	9.16	83.05	21.67		65.0	
10247-CAB	LTE-TDD (SC-FDMA, 50% RB, 5 MHz, 16-QAM)	X	8.25	78.94	21.22	3.98	65.0	± 9.6 %
		Y	7.85	77.32	20.79		65.0	
		Z	7.47	77.61	20.18		65.0	
10248-CAB	LTE-TDD (SC-FDMA, 50% RB, 5 MHz, 64-QAM)	X	8.20	78.37	20.99	3.98	65.0	± 9.6 %
		Y	7.89	76.93	20.61		65.0	
		Z	7.41	77.03	19.93		65.0	
10249-CAB	LTE-TDD (SC-FDMA, 50% RB, 5 MHz, QPSK)	X	11.20	86.28	23.89	3.98	65.0	± 9.6 %
		Y	9.29	82.26	22.62		65.0	
		Z	10.48	85.66	23.36		65.0	
10250-CAB	LTE-TDD (SC-FDMA, 50% RB, 10 MHz, 16-QAM)	X	8.93	80.25	22.81	3.98	65.0	± 9.6 %
		Y	8.46	78.37	22.14		65.0	
		Z	8.46	79.88	22.48		65.0	
10251-CAB	LTE-TDD (SC-FDMA, 50% RB, 10 MHz, 64-QAM)	X	8.39	77.98	21.64	3.98	65.0	± 9.6 %
		Y	8.12	76.54	21.14		65.0	
		Z	7.98	77.74	21.34		65.0	
10252-CAB	LTE-TDD (SC-FDMA, 50% RB, 10 MHz, QPSK)	X	10.53	84.51	23.78	3.98	65.0	± 9.6 %
		Y	9.19	81.18	22.63		65.0	
		Z	10.24	84.82	23.86		65.0	
10253-CAB	LTE-TDD (SC-FDMA, 50% RB, 15 MHz, 16-QAM)	X	8.25	76.95	21.44	3.98	65.0	± 9.6 %
		Y	8.10	75.77	21.00		65.0	
		Z	7.89	76.78	21.28		65.0	
10254-CAB	LTE-TDD (SC-FDMA, 50% RB, 15 MHz, 64-QAM)	X	8.62	77.66	22.02	3.98	65.0	± 9.6 %
		Y	8.44	76.43	21.56		65.0	
		Z	8.28	77.57	21.89		65.0	

10255-CAB	LTE-TDD (SC-FDMA, 50% RB, 15 MHz, QPSK)	X	9.25	80.67	22.52	3.98	65.0	± 9.6 %
		Y	8.61	78.53	21.74		65.0	
		Z	9.00	80.97	22.67		65.0	
10256-CAA	LTE-TDD (SC-FDMA, 100% RB, 1.4 MHz, 16-QAM)	X	10.45	81.80	21.06	3.98	65.0	± 9.6 %
		Y	9.25	79.43	20.63		65.0	
		Z	8.10	77.76	18.69		65.0	
10257-CAA	LTE-TDD (SC-FDMA, 100% RB, 1.4 MHz, 64-QAM)	X	10.14	80.97	20.68	3.98	65.0	± 9.6 %
		Y	9.17	78.95	20.38		65.0	
		Z	7.78	76.81	18.23		65.0	
10258-CAA	LTE-TDD (SC-FDMA, 100% RB, 1.4 MHz, QPSK)	X	9.51	83.16	21.76	3.98	65.0	± 9.6 %
		Y	8.34	80.46	21.12		65.0	
		Z	7.35	79.00	19.46		65.0	
10259-CAB	LTE-TDD (SC-FDMA, 100% RB, 3 MHz, 16-QAM)	X	8.50	79.32	21.74	3.98	65.0	± 9.6 %
		Y	8.08	77.61	21.22		65.0	
		Z	7.86	78.44	21.00		65.0	
10260-CAB	LTE-TDD (SC-FDMA, 100% RB, 3 MHz, 64-QAM)	X	8.50	79.04	21.65	3.98	65.0	± 9.6 %
		Y	8.14	77.44	21.18		65.0	
		Z	7.85	78.11	20.87		65.0	
10261-CAB	LTE-TDD (SC-FDMA, 100% RB, 3 MHz, QPSK)	X	10.46	84.88	23.66	3.98	65.0	± 9.6 %
		Y	8.99	81.35	22.49		65.0	
		Z	9.90	84.54	23.31		65.0	
10262-CAB	LTE-TDD (SC-FDMA, 100% RB, 5 MHz, 16-QAM)	X	8.92	80.22	22.77	3.98	65.0	± 9.6 %
		Y	8.45	78.35	22.11		65.0	
		Z	8.45	79.83	22.45		65.0	
10263-CAB	LTE-TDD (SC-FDMA, 100% RB, 5 MHz, 64-QAM)	X	8.39	77.98	21.64	3.98	65.0	± 9.6 %
		Y	8.12	76.54	21.14		65.0	
		Z	7.97	77.72	21.33		65.0	
10264-CAB	LTE-TDD (SC-FDMA, 100% RB, 5 MHz, QPSK)	X	10.46	84.37	23.71	3.98	65.0	± 9.6 %
		Y	9.15	81.08	22.57		65.0	
		Z	10.16	84.65	23.78		65.0	
10265-CAB	LTE-TDD (SC-FDMA, 100% RB, 10 MHz, 16-QAM)	X	8.50	77.59	21.64	3.98	65.0	± 9.6 %
		Y	8.29	76.32	21.16		65.0	
		Z	8.08	77.33	21.51		65.0	
10266-CAB	LTE-TDD (SC-FDMA, 100% RB, 10 MHz, 64-QAM)	X	8.85	78.27	22.25	3.98	65.0	± 9.6 %
		Y	8.62	76.95	21.75		65.0	
		Z	8.48	78.14	22.17		65.0	
10267-CAB	LTE-TDD (SC-FDMA, 100% RB, 10 MHz, QPSK)	X	9.58	81.04	22.42	3.98	65.0	± 9.6 %
		Y	8.86	78.85	21.63		65.0	
		Z	9.31	81.34	22.60		65.0	
10268-CAB	LTE-TDD (SC-FDMA, 100% RB, 15 MHz, 16-QAM)	X	8.89	76.95	21.70	3.98	65.0	± 9.6 %
		Y	8.78	75.95	21.31		65.0	
		Z	8.54	76.83	21.69		65.0	
10269-CAB	LTE-TDD (SC-FDMA, 100% RB, 15 MHz, 64-QAM)	X	8.79	76.51	21.59	3.98	65.0	± 9.6 %
		Y	8.71	75.58	21.23		65.0	
		Z	8.47	76.42	21.58		65.0	
10270-CAB	LTE-TDD (SC-FDMA, 100% RB, 15 MHz, QPSK)	X	8.98	78.26	21.47	3.98	65.0	± 9.6 %
		Y	8.66	76.86	20.96		65.0	
		Z	8.70	78.39	21.61		65.0	

10274-CAB	UMTS-FDD (HSUPA, Subtest 5, 3GPP Rel8.10)	X	2.76	67.40	16.12	0.00	150.0	± 9.6 %
		Y	2.68	66.20	15.35		150.0	
		Z	2.61	66.55	15.21		150.0	
10275-CAB	UMTS-FDD (HSUPA, Subtest 5, 3GPP Rel8.4)	X	1.97	71.33	17.64	0.00	150.0	± 9.6 %
		Y	1.71	67.84	15.61		150.0	
		Z	1.63	67.82	15.44		150.0	
10277-CAA	PHS (QPSK)	X	5.79	70.12	14.44	9.03	50.0	± 9.6 %
		Y	6.71	72.04	16.24		50.0	
		Z	5.20	69.01	13.39		50.0	
10278-CAA	PHS (QPSK, BW 884MHz, Rolloff 0.5)	X	10.14	81.72	21.64	9.03	50.0	± 9.6 %
		Y	10.00	81.13	22.16		50.0	
		Z	8.80	79.36	20.19		50.0	
10279-CAA	PHS (QPSK, BW 884MHz, Rolloff 0.38)	X	10.33	81.92	21.72	9.03	50.0	± 9.6 %
		Y	10.19	81.33	22.24		50.0	
		Z	8.92	79.53	20.27		50.0	
10290-AAB	CDMA2000, RC1, SO55, Full Rate	X	2.41	75.76	18.30	0.00	150.0	± 9.6 %
		Y	1.70	69.18	15.23		150.0	
		Z	1.46	68.58	14.00		150.0	
10291-AAB	CDMA2000, RC3, SO55, Full Rate	X	1.39	73.22	17.31	0.00	150.0	± 9.6 %
		Y	0.98	66.45	13.79		150.0	
		Z	0.85	65.74	12.53		150.0	
10292-AAB	CDMA2000, RC3, SO32, Full Rate	X	2.43	83.14	21.70	0.00	150.0	± 9.6 %
		Y	1.15	69.63	15.75		150.0	
		Z	1.04	69.40	14.71		150.0	
10293-AAB	CDMA2000, RC3, SO3, Full Rate	X	5.22	96.14	26.57	0.00	150.0	± 9.6 %
		Y	1.48	73.58	17.97		150.0	
		Z	1.47	74.43	17.37		150.0	
10295-AAB	CDMA2000, RC1, SO3, 1/8th Rate 25 fr.	X	10.48	83.75	24.32	9.03	50.0	± 9.6 %
		Y	9.84	81.54	23.85		50.0	
		Z	11.88	86.37	24.91		50.0	
10297-AAA	LTE-FDD (SC-FDMA, 50% RB, 20 MHz, QPSK)	X	3.28	72.37	17.95	0.00	150.0	± 9.6 %
		Y	2.98	69.95	16.59		150.0	
		Z	2.77	69.63	16.49		150.0	
10298-AAB	LTE-FDD (SC-FDMA, 50% RB, 3 MHz, QPSK)	X	2.26	72.62	17.48	0.00	150.0	± 9.6 %
		Y	1.88	68.51	15.39		150.0	
		Z	1.59	67.65	14.14		150.0	
10299-AAB	LTE-FDD (SC-FDMA, 50% RB, 3 MHz, 16-QAM)	X	6.40	81.89	20.37	0.00	150.0	± 9.6 %
		Y	3.78	73.44	17.26		150.0	
		Z	3.62	73.66	16.18		150.0	
10300-AAB	LTE-FDD (SC-FDMA, 50% RB, 3 MHz, 64-QAM)	X	3.72	72.73	16.07	0.00	150.0	± 9.6 %
		Y	2.96	68.88	14.55		150.0	
		Z	2.44	67.52	12.75		150.0	
10301-AAA	IEEE 802.16e WIMAX (29:18, 5ms, 10MHz, QPSK, PUSC)	X	5.70	68.03	18.84	4.17	80.0	± 9.6 %
		Y	5.77	67.36	18.35		80.0	
		Z	5.64	68.37	18.74		80.0	
10302-AAA	IEEE 802.16e WIMAX (29:18, 5ms, 10MHz, QPSK, PUSC, 3 CTRL symbols)	X	6.21	68.72	19.60	4.96	80.0	± 9.6 %
		Y	6.41	68.65	19.47		80.0	
		Z	6.13	69.05	19.54		80.0	

10303-AAA	IEEE 802.16e WiMAX (31:15, 5ms, 10MHz, 64QAM, PUSC)	X	6.07	68.83	19.70	4.96	80.0	± 9.6 %
		Y	6.30	68.82	19.58		80.0	
		Z	5.97	69.08	19.56		80.0	
10304-AAA	IEEE 802.16e WiMAX (29:18, 5ms, 10MHz, 64QAM, PUSC)	X	5.71	68.13	18.89	4.17	80.0	± 9.6 %
		Y	5.89	68.01	18.73		80.0	
		Z	5.61	68.35	18.73		80.0	
10305-AAA	IEEE 802.16e WiMAX (31:15, 10ms, 10MHz, 64QAM, PUSC, 15 symbols)	X	6.90	74.81	23.11	6.02	50.0	± 9.6 %
		Y	9.48	82.28	26.60		50.0	
		Z	9.03	82.45	26.20		50.0	
10306-AAA	IEEE 802.16e WiMAX (29:18, 10ms, 10MHz, 64QAM, PUSC, 18 symbols)	X	6.40	71.34	21.64	6.02	50.0	± 9.6 %
		Y	6.75	71.50	21.57		50.0	
		Z	6.43	72.04	21.56		50.0	
10307-AAA	IEEE 802.16e WiMAX (29:18, 10ms, 10MHz, QPSK, PUSC, 18 symbols)	X	6.49	72.10	21.82	6.02	50.0	± 9.6 %
		Y	6.85	72.21	21.70		50.0	
		Z	6.50	72.67	21.67		50.0	
10308-AAA	IEEE 802.16e WiMAX (29:18, 10ms, 10MHz, 16QAM, PUSC)	X	6.53	72.49	22.02	6.02	50.0	± 9.6 %
		Y	6.89	72.58	21.88		50.0	
		Z	6.59	73.18	21.92		50.0	
10309-AAA	IEEE 802.16e WiMAX (29:18, 10ms, 10MHz, 16QAM, AMC 2x3, 18 symbols)	X	6.52	71.66	21.81	6.02	50.0	± 9.6 %
		Y	6.86	71.77	21.70		50.0	
		Z	6.53	72.35	21.74		50.0	
10310-AAA	IEEE 802.16e WiMAX (29:18, 10ms, 10MHz, QPSK, AMC 2x3, 18 symbols)	X	6.41	71.57	21.66	6.02	50.0	± 9.6 %
		Y	6.75	71.71	21.56		50.0	
		Z	6.45	72.29	21.59		50.0	
10311-AAA	LTE-FDD (SC-FDMA, 100% RB, 15 MHz, QPSK)	X	3.66	71.55	17.51	0.00	150.0	± 9.6 %
		Y	3.33	69.32	16.27		150.0	
		Z	3.12	68.94	16.14		150.0	
10313-AAA	iDEN 1:3	X	8.19	79.62	19.16	6.99	70.0	± 9.6 %
		Y	7.35	77.72	18.90		70.0	
		Z	8.21	80.46	19.57		70.0	
10314-AAA	iDEN 1:6	X	11.35	86.83	24.06	10.00	30.0	± 9.6 %
		Y	8.72	81.68	22.69		30.0	
		Z	10.81	87.34	24.49		30.0	
10315-AAB	IEEE 802.11b WiFi 2.4 GHz (DSSS, 1 Mbps, 96pc duty cycle)	X	1.24	66.34	16.99	0.17	150.0	± 9.6 %
		Y	1.18	64.44	15.46		150.0	
		Z	1.17	64.45	15.36		150.0	
10316-AAB	IEEE 802.11g WiFi 2.4 GHz (ERP-OFDM, 6 Mbps, 96pc duty cycle)	X	4.83	67.25	16.68	0.17	150.0	± 9.6 %
		Y	4.86	66.88	16.43		150.0	
		Z	4.68	66.99	16.39		150.0	
10317-AAB	IEEE 802.11a WiFi 5 GHz (OFDM, 6 Mbps, 96pc duty cycle)	X	4.83	67.25	16.68	0.17	150.0	± 9.6 %
		Y	4.86	66.88	16.43		150.0	
		Z	4.68	66.99	16.39		150.0	
10400-AAC	IEEE 802.11ac WiFi (20MHz, 64-QAM, 99pc duty cycle)	X	4.96	67.54	16.61	0.00	150.0	± 9.6 %
		Y	4.98	67.13	16.32		150.0	
		Z	4.75	67.19	16.29		150.0	
10401-AAC	IEEE 802.11ac WiFi (40MHz, 64-QAM, 99pc duty cycle)	X	5.54	67.49	16.61	0.00	150.0	± 9.6 %
		Y	5.56	67.14	16.37		150.0	
		Z	5.45	67.43	16.49		150.0	

10402-AAC	IEEE 802.11ac WiFi (80MHz, 64-QAM, 99pc duty cycle)	X	5.87	68.11	16.75	0.00	150.0	± 9.6 %
		Y	5.89	67.80	16.54		150.0	
		Z	5.70	67.70	16.47		150.0	
10403-AAB	CDMA2000 (1xEV-DO, Rev. 0)	X	2.41	75.76	18.30	0.00	115.0	± 9.6 %
		Y	1.70	69.18	15.23		115.0	
		Z	1.46	68.58	14.00		115.0	
10404-AAB	CDMA2000 (1xEV-DO, Rev. A)	X	2.41	75.76	18.30	0.00	115.0	± 9.6 %
		Y	1.70	69.18	15.23		115.0	
		Z	1.46	68.58	14.00		115.0	
10406-AAB	CDMA2000, RC3, SO32, SCH0, Full Rate	X	100.00	120.32	30.30	0.00	100.0	± 9.6 %
		Y	37.67	108.93	28.46		100.0	
		Z	100.00	119.28	29.39		100.0	
10410-AAA	LTE-TDD (SC-FDMA, 1 RB, 10 MHz, QPSK, UL Subframe=2,3,4,7,8,9)	X	100.00	118.51	29.90	3.23	80.0	± 9.6 %
		Y	100.00	119.74	30.88		80.0	
		Z	100.00	120.99	30.71		80.0	
10415-AAA	IEEE 802.11b WiFi 2.4 GHz (DSSS, 1 Mbps, 99pc duty cycle)	X	1.06	64.54	16.02	0.00	150.0	± 9.6 %
		Y	1.03	62.90	14.57		150.0	
		Z	1.03	63.04	14.51		150.0	
10416-AAA	IEEE 802.11g WiFi 2.4 GHz (ERP-OFDM, 6 Mbps, 99pc duty cycle)	X	4.73	67.12	16.55	0.00	150.0	± 9.6 %
		Y	4.75	66.70	16.25		150.0	
		Z	4.58	66.83	16.23		150.0	
10417-AAA	IEEE 802.11a/h WiFi 5 GHz (OFDM, 6 Mbps, 99pc duty cycle)	X	4.73	67.12	16.55	0.00	150.0	± 9.6 %
		Y	4.75	66.70	16.25		150.0	
		Z	4.58	66.83	16.23		150.0	
10418-AAA	IEEE 802.11g WiFi 2.4 GHz (DSSS-OFDM, 6 Mbps, 99pc duty cycle, Long preamble)	X	4.72	67.27	16.56	0.00	150.0	± 9.6 %
		Y	4.73	66.83	16.25		150.0	
		Z	4.56	66.98	16.24		150.0	
10419-AAA	IEEE 802.11g WiFi 2.4 GHz (DSSS-OFDM, 6 Mbps, 99pc duty cycle, Short preamble)	X	4.75	67.23	16.56	0.00	150.0	± 9.6 %
		Y	4.76	66.80	16.26		150.0	
		Z	4.59	66.94	16.24		150.0	
10422-AAA	IEEE 802.11n (HT Greenfield, 7.2 Mbps, BPSK)	X	4.87	67.22	16.56	0.00	150.0	± 9.6 %
		Y	4.89	66.82	16.28		150.0	
		Z	4.71	66.94	16.26		150.0	
10423-AAA	IEEE 802.11n (HT Greenfield, 43.3 Mbps, 16-QAM)	X	5.09	67.62	16.71	0.00	150.0	± 9.6 %
		Y	5.12	67.23	16.44		150.0	
		Z	4.88	67.27	16.38		150.0	
10424-AAA	IEEE 802.11n (HT Greenfield, 72.2 Mbps, 64-QAM)	X	5.00	67.56	16.68	0.00	150.0	± 9.6 %
		Y	5.02	67.15	16.39		150.0	
		Z	4.80	67.22	16.35		150.0	
10425-AAA	IEEE 802.11n (HT Greenfield, 15 Mbps, BPSK)	X	5.55	67.83	16.78	0.00	150.0	± 9.6 %
		Y	5.59	67.55	16.57		150.0	
		Z	5.40	67.57	16.55		150.0	
10426-AAA	IEEE 802.11n (HT Greenfield, 90 Mbps, 16-QAM)	X	5.56	67.88	16.79	0.00	150.0	± 9.6 %
		Y	5.60	67.58	16.58		150.0	
		Z	5.41	67.59	16.56		150.0	

10427-AAA	IEEE 802.11n (HT Greenfield, 150 Mbps, 64-QAM)	X	5.59	67.91	16.80	0.00	150.0	± 9.6 %
		Y	5.63	67.61	16.59		150.0	
		Z	5.42	67.56	16.54		150.0	
10430-AAA	LTE-FDD (OFDMA, 5 MHz, E-TM 3.1)	X	4.54	71.07	18.70	0.00	150.0	± 9.6 %
		Y	4.46	69.99	18.11		150.0	
		Z	4.20	70.41	17.89		150.0	
10431-AAA	LTE-FDD (OFDMA, 10 MHz, E-TM 3.1)	X	4.50	67.77	16.69	0.00	150.0	± 9.6 %
		Y	4.51	67.23	16.34		150.0	
		Z	4.26	67.36	16.21		150.0	
10432-AAA	LTE-FDD (OFDMA, 15 MHz, E-TM 3.1)	X	4.78	67.63	16.67	0.00	150.0	± 9.6 %
		Y	4.80	67.18	16.37		150.0	
		Z	4.56	67.25	16.29		150.0	
10433-AAA	LTE-FDD (OFDMA, 20 MHz, E-TM 3.1)	X	5.01	67.62	16.71	0.00	150.0	± 9.6 %
		Y	5.04	67.21	16.43		150.0	
		Z	4.81	67.25	16.37		150.0	
10434-AAA	W-CDMA (BS Test Model 1, 64 DPCH)	X	4.66	71.93	18.79	0.00	150.0	± 9.6 %
		Y	4.53	70.61	18.11		150.0	
		Z	4.27	71.15	17.82		150.0	
10435-AAA	LTE-TDD (SC-FDMA, 1 RB, 20 MHz, QPSK, UL Subframe=2,3,4,7,8,9)	X	100.00	118.35	29.82	3.23	80.0	± 9.6 %
		Y	100.00	119.61	30.82		80.0	
		Z	100.00	120.81	30.62		80.0	
10447-AAA	LTE-FDD (OFDMA, 5 MHz, E-TM 3.1, Clipping 44%)	X	3.85	68.02	16.38	0.00	150.0	± 9.6 %
		Y	3.83	67.22	15.92		150.0	
		Z	3.54	67.32	15.53		150.0	
10448-AAA	LTE-FDD (OFDMA, 10 MHz, E-TM 3.1, Clipping 44%)	X	4.31	67.56	16.56	0.00	150.0	± 9.6 %
		Y	4.32	66.99	16.19		150.0	
		Z	4.10	67.13	16.07		150.0	
10449-AAA	LTE-FDD (OFDMA, 15 MHz, E-TM 3.1, Clipping 44%)	X	4.56	67.47	16.59	0.00	150.0	± 9.6 %
		Y	4.57	66.98	16.26		150.0	
		Z	4.37	67.07	16.19		150.0	
10450-AAA	LTE-FDD (OFDMA, 20 MHz, E-TM 3.1, Clipping 44%)	X	4.73	67.38	16.58	0.00	150.0	± 9.6 %
		Y	4.74	66.94	16.27		150.0	
		Z	4.56	67.01	16.22		150.0	
10451-AAA	W-CDMA (BS Test Model 1, 64 DPCH, Clipping 44%)	X	3.81	68.42	16.23	0.00	150.0	± 9.6 %
		Y	3.77	67.50	15.73		150.0	
		Z	3.44	67.49	15.16		150.0	
10456-AAA	IEEE 802.11ac WiFi (160MHz, 64-QAM, 99pc duty cycle)	X	6.40	68.45	16.93	0.00	150.0	± 9.6 %
		Y	6.44	68.23	16.77		150.0	
		Z	6.27	68.12	16.71		150.0	
10457-AAA	UMTS-FDD (DC-HSDPA)	X	3.89	65.77	16.30	0.00	150.0	± 9.6 %
		Y	3.90	65.36	15.99		150.0	
		Z	3.82	65.47	15.93		150.0	
10458-AAA	CDMA2000 (1xEV-DO, Rev. B, 2 carriers)	X	3.60	67.53	15.71	0.00	150.0	± 9.6 %
		Y	3.56	66.59	15.22		150.0	
		Z	3.27	66.88	14.62		150.0	
10459-AAA	CDMA2000 (1xEV-DO, Rev. B, 3 carriers)	X	4.70	65.53	16.21	0.00	150.0	± 9.6 %
		Y	4.63	64.60	15.71		150.0	
		Z	4.27	64.85	15.38		150.0	

10460-AAA	UMTS-FDD (WCDMA, AMR)	X	1.28	75.29	20.20	0.00	150.0	± 9.6 %
		Y	0.92	67.71	15.91		150.0	
		Z	0.90	67.71	15.78		150.0	
10461-AAA	LTE-TDD (SC-FDMA, 1 RB, 1.4 MHz, QPSK, UL Subframe=2,3,4,7,8,9)	X	100.00	122.97	32.01	3.29	80.0	± 9.6 %
		Y	100.00	121.34	31.70		80.0	
		Z	100.00	125.58	32.88		80.0	
10462-AAA	LTE-TDD (SC-FDMA, 1 RB, 1.4 MHz, 16-QAM, UL Subframe=2,3,4,7,8,9)	X	100.00	108.03	24.84	3.23	80.0	± 9.6 %
		Y	100.00	109.86	26.18		80.0	
		Z	100.00	108.99	24.93		80.0	
10463-AAA	LTE-TDD (SC-FDMA, 1 RB, 1.4 MHz, 64-QAM, UL Subframe=2,3,4,7,8,9)	X	100.00	105.21	23.49	3.23	80.0	± 9.6 %
		Y	47.92	99.26	23.13		80.0	
		Z	100.00	105.71	23.36		80.0	
10464-AAA	LTE-TDD (SC-FDMA, 1 RB, 3 MHz, QPSK, UL Subframe=2,3,4,7,8,9)	X	100.00	121.12	31.00	3.23	80.0	± 9.6 %
		Y	100.00	119.76	30.82		80.0	
		Z	100.00	123.61	31.80		80.0	
10465-AAA	LTE-TDD (SC-FDMA, 1 RB, 3 MHz, 16-QAM, UL Subframe=2,3,4,7,8,9)	X	100.00	107.54	24.59	3.23	80.0	± 9.6 %
		Y	92.10	108.50	25.75		80.0	
		Z	100.00	108.47	24.68		80.0	
10466-AAA	LTE-TDD (SC-FDMA, 1 RB, 3 MHz, 64-QAM, UL Subframe=2,3,4,7,8,9)	X	100.00	104.76	23.28	3.23	80.0	± 9.6 %
		Y	27.79	92.79	21.40		80.0	
		Z	53.71	98.96	21.73		80.0	
10467-AAA	LTE-TDD (SC-FDMA, 1 RB, 5 MHz, QPSK, UL Subframe=2,3,4,7,8,9)	X	100.00	121.32	31.10	3.23	80.0	± 9.6 %
		Y	100.00	119.93	30.90		80.0	
		Z	100.00	123.83	31.91		80.0	
10468-AAA	LTE-TDD (SC-FDMA, 1 RB, 5 MHz, 16-QAM, UL Subframe=2,3,4,7,8,9)	X	100.00	107.68	24.66	3.23	80.0	± 9.6 %
		Y	100.00	109.58	26.02		80.0	
		Z	100.00	108.64	24.75		80.0	
10469-AAA	LTE-TDD (SC-FDMA, 1 RB, 5 MHz, 64-QAM, UL Subframe=2,3,4,7,8,9)	X	100.00	104.76	23.27	3.23	80.0	± 9.6 %
		Y	28.45	93.06	21.47		80.0	
		Z	57.15	99.60	21.88		80.0	
10470-AAA	LTE-TDD (SC-FDMA, 1 RB, 10 MHz, QPSK, UL Subframe=2,3,4,7,8,9)	X	100.00	121.35	31.10	3.23	80.0	± 9.6 %
		Y	100.00	119.95	30.90		80.0	
		Z	100.00	123.86	31.91		80.0	
10471-AAA	LTE-TDD (SC-FDMA, 1 RB, 10 MHz, 16-QAM, UL Subframe=2,3,4,7,8,9)	X	100.00	107.63	24.63	3.23	80.0	± 9.6 %
		Y	100.00	109.54	26.00		80.0	
		Z	100.00	108.59	24.73		80.0	
10472-AAA	LTE-TDD (SC-FDMA, 1 RB, 10 MHz, 64-QAM, UL Subframe=2,3,4,7,8,9)	X	100.00	104.72	23.24	3.23	80.0	± 9.6 %
		Y	28.52	93.08	21.46		80.0	
		Z	57.07	99.54	21.85		80.0	
10473-AAA	LTE-TDD (SC-FDMA, 1 RB, 15 MHz, QPSK, UL Subframe=2,3,4,7,8,9)	X	100.00	121.32	31.09	3.23	80.0	± 9.6 %
		Y	100.00	119.92	30.89		80.0	
		Z	100.00	123.84	31.90		80.0	
10474-AAA	LTE-TDD (SC-FDMA, 1 RB, 15 MHz, 16-QAM, UL Subframe=2,3,4,7,8,9)	X	100.00	107.64	24.63	3.23	80.0	± 9.6 %
		Y	100.00	109.55	26.00		80.0	
		Z	100.00	108.60	24.73		80.0	
10475-AAA	LTE-TDD (SC-FDMA, 1 RB, 15 MHz, 64-QAM, UL Subframe=2,3,4,7,8,9)	X	100.00	104.73	23.25	3.23	80.0	± 9.6 %
		Y	28.13	92.93	21.42		80.0	
		Z	55.36	99.25	21.78		80.0	

10477-AAA	LTE-TDD (SC-FDMA, 1 RB, 20 MHz, 16-QAM, UL Subframe=2,3,4,7,8,9)	X	100.00	107.49	24.56	3.23	80.0	± 9.6 %
		Y	96.57	109.01	25.85		80.0	
		Z	100.00	108.42	24.64		80.0	
10478-AAA	LTE-TDD (SC-FDMA, 1 RB, 20 MHz, 64-QAM, UL Subframe=2,3,4,7,8,9)	X	100.00	104.68	23.23	3.23	80.0	± 9.6 %
		Y	27.68	92.72	21.36		80.0	
		Z	53.23	98.81	21.67		80.0	
10479-AAA	LTE-TDD (SC-FDMA, 50% RB, 1.4 MHz, QPSK, UL Subframe=2,3,4,7,8,9)	X	26.63	104.01	29.13	3.23	80.0	± 9.6 %
		Y	9.63	86.48	23.96		80.0	
		Z	24.30	102.59	28.22		80.0	
10480-AAA	LTE-TDD (SC-FDMA, 50% RB, 1.4 MHz, 16-QAM, UL Subframe=2,3,4,7,8,9)	X	38.31	102.90	27.02	3.23	80.0	± 9.6 %
		Y	11.50	85.06	22.20		80.0	
		Z	29.11	98.49	25.10		80.0	
10481-AAA	LTE-TDD (SC-FDMA, 50% RB, 1.4 MHz, 64-QAM, UL Subframe=2,3,4,7,8,9)	X	30.40	98.59	25.52	3.23	80.0	± 9.6 %
		Y	10.74	83.47	21.41		80.0	
		Z	20.94	92.98	23.18		80.0	
10482-AAA	LTE-TDD (SC-FDMA, 50% RB, 3 MHz, QPSK, UL Subframe=2,3,4,7,8,9)	X	8.51	84.82	22.25	2.23	80.0	± 9.6 %
		Y	5.60	77.58	19.80		80.0	
		Z	5.41	78.09	19.19		80.0	
10483-AAA	LTE-TDD (SC-FDMA, 50% RB, 3 MHz, 16-QAM, UL Subframe=2,3,4,7,8,9)	X	14.01	88.92	23.41	2.23	80.0	± 9.6 %
		Y	8.14	80.18	20.73		80.0	
		Z	9.32	82.50	20.44		80.0	
10484-AAA	LTE-TDD (SC-FDMA, 50% RB, 3 MHz, 64-QAM, UL Subframe=2,3,4,7,8,9)	X	12.47	87.00	22.82	2.23	80.0	± 9.6 %
		Y	7.81	79.33	20.43		80.0	
		Z	8.26	80.64	19.81		80.0	
10485-AAA	LTE-TDD (SC-FDMA, 50% RB, 5 MHz, QPSK, UL Subframe=2,3,4,7,8,9)	X	8.06	84.25	22.66	2.23	80.0	± 9.6 %
		Y	5.75	77.87	20.37		80.0	
		Z	5.68	79.10	20.42		80.0	
10486-AAA	LTE-TDD (SC-FDMA, 50% RB, 5 MHz, 16-QAM, UL Subframe=2,3,4,7,8,9)	X	5.66	75.87	19.43	2.23	80.0	± 9.6 %
		Y	4.94	72.86	18.29		80.0	
		Z	4.62	73.05	17.69		80.0	
10487-AAA	LTE-TDD (SC-FDMA, 50% RB, 5 MHz, 64-QAM, UL Subframe=2,3,4,7,8,9)	X	5.56	75.25	19.19	2.23	80.0	± 9.6 %
		Y	4.94	72.51	18.16		80.0	
		Z	4.56	72.51	17.46		80.0	
10488-AAA	LTE-TDD (SC-FDMA, 50% RB, 10 MHz, QPSK, UL Subframe=2,3,4,7,8,9)	X	7.10	80.82	21.84	2.23	80.0	± 9.6 %
		Y	5.79	76.47	20.13		80.0	
		Z	5.49	77.19	20.36		80.0	
10489-AAA	LTE-TDD (SC-FDMA, 50% RB, 10 MHz, 16-QAM, UL Subframe=2,3,4,7,8,9)	X	5.34	73.87	19.44	2.23	80.0	± 9.6 %
		Y	5.00	71.87	18.57		80.0	
		Z	4.68	72.17	18.47		80.0	
10490-AAA	LTE-TDD (SC-FDMA, 50% RB, 10 MHz, 64-QAM, UL Subframe=2,3,4,7,8,9)	X	5.35	73.36	19.26	2.23	80.0	± 9.6 %
		Y	5.06	71.53	18.46		80.0	
		Z	4.74	71.87	18.36		80.0	
10491-AAA	LTE-TDD (SC-FDMA, 50% RB, 15 MHz, QPSK, UL Subframe=2,3,4,7,8,9)	X	6.36	77.12	20.56	2.23	80.0	± 9.6 %
		Y	5.66	74.28	19.36		80.0	
		Z	5.31	74.67	19.54		80.0	
10492-AAA	LTE-TDD (SC-FDMA, 50% RB, 15 MHz, 16-QAM, UL Subframe=2,3,4,7,8,9)	X	5.41	72.24	18.98	2.23	80.0	± 9.6 %
		Y	5.23	70.84	18.33		80.0	
		Z	4.89	71.01	18.29		80.0	

10493-AAA	LTE-TDD (SC-FDMA, 50% RB, 15 MHz, 64-QAM, UL Subframe=2,3,4,7,8,9)	X	5.44	71.94	18.88	2.23	80.0	± 9.6 %
		Y	5.28	70.63	18.27		80.0	
		Z	4.94	70.81	18.22		80.0	
10494-AAA	LTE-TDD (SC-FDMA, 50% RB, 20 MHz, QPSK, UL Subframe=2,3,4,7,8,9)	X	7.43	79.70	21.31	2.23	80.0	± 9.6 %
		Y	6.30	76.13	19.88		80.0	
		Z	5.88	76.40	20.05		80.0	
10495-AAA	LTE-TDD (SC-FDMA, 50% RB, 20 MHz, 16-QAM, UL Subframe=2,3,4,7,8,9)	X	5.56	72.97	19.25	2.23	80.0	± 9.6 %
		Y	5.33	71.45	18.55		80.0	
		Z	4.97	71.48	18.50		80.0	
10496-AAA	LTE-TDD (SC-FDMA, 50% RB, 20 MHz, 64-QAM, UL Subframe=2,3,4,7,8,9)	X	5.54	72.39	19.06	2.23	80.0	± 9.6 %
		Y	5.37	71.03	18.42		80.0	
		Z	5.01	71.08	18.38		80.0	
10497-AAA	LTE-TDD (SC-FDMA, 100% RB, 1.4 MHz, QPSK, UL Subframe=2,3,4,7,8,9)	X	7.31	82.38	20.82	2.23	80.0	± 9.6 %
		Y	4.87	75.75	18.64		80.0	
		Z	4.03	73.68	16.68		80.0	
10498-AAA	LTE-TDD (SC-FDMA, 100% RB, 1.4 MHz, 16-QAM, UL Subframe=2,3,4,7,8,9)	X	4.73	73.29	16.69	2.23	80.0	± 9.6 %
		Y	4.12	70.77	15.97		80.0	
		Z	2.73	66.24	12.60		80.0	
10499-AAA	LTE-TDD (SC-FDMA, 100% RB, 1.4 MHz, 64-QAM, UL Subframe=2,3,4,7,8,9)	X	4.59	72.54	16.27	2.23	80.0	± 9.6 %
		Y	4.10	70.38	15.70		80.0	
		Z	2.62	65.47	12.11		80.0	
10500-AAA	LTE-TDD (SC-FDMA, 100% RB, 3 MHz, QPSK, UL Subframe=2,3,4,7,8,9)	X	7.19	81.83	22.01	2.23	80.0	± 9.6 %
		Y	5.57	76.69	20.07		80.0	
		Z	5.44	77.85	20.24		80.0	
10501-AAA	LTE-TDD (SC-FDMA, 100% RB, 3 MHz, 16-QAM, UL Subframe=2,3,4,7,8,9)	X	5.46	74.81	19.33	2.23	80.0	± 9.6 %
		Y	4.94	72.30	18.33		80.0	
		Z	4.65	72.67	17.97		80.0	
10502-AAA	LTE-TDD (SC-FDMA, 100% RB, 3 MHz, 64-QAM, UL Subframe=2,3,4,7,8,9)	X	5.46	74.43	19.15	2.23	80.0	± 9.6 %
		Y	4.98	72.05	18.20		80.0	
		Z	4.68	72.41	17.81		80.0	
10503-AAA	LTE-TDD (SC-FDMA, 100% RB, 5 MHz, QPSK, UL Subframe=2,3,4,7,8,9)	X	6.99	80.56	21.73	2.23	80.0	± 9.6 %
		Y	5.72	76.28	20.04		80.0	
		Z	5.42	76.98	20.27		80.0	
10504-AAA	LTE-TDD (SC-FDMA, 100% RB, 5 MHz, 16-QAM, UL Subframe=2,3,4,7,8,9)	X	5.31	73.78	19.39	2.23	80.0	± 9.6 %
		Y	4.98	71.79	18.52		80.0	
		Z	4.66	72.08	18.42		80.0	
10505-AAA	LTE-TDD (SC-FDMA, 100% RB, 5 MHz, 64-QAM, UL Subframe=2,3,4,7,8,9)	X	5.32	73.26	19.21	2.23	80.0	± 9.6 %
		Y	5.03	71.44	18.41		80.0	
		Z	4.72	71.78	18.31		80.0	
10506-AAA	LTE-TDD (SC-FDMA, 100% RB, 10 MHz, QPSK, UL Subframe=2,3,4,7,8,9)	X	7.35	79.52	21.23	2.23	80.0	± 9.6 %
		Y	6.24	75.99	19.82		80.0	
		Z	5.83	76.25	19.98		80.0	
10507-AAA	LTE-TDD (SC-FDMA, 100% RB, 10 MHz, 16-QAM, UL Subframe=2,3,4,7,8,9)	X	5.53	72.90	19.22	2.23	80.0	± 9.6 %
		Y	5.31	71.39	18.51		80.0	
		Z	4.95	71.42	18.47		80.0	

10508-AAA	LTE-TDD (SC-FDMA, 100% RB, 10 MHz, 64-QAM, UL Subframe=2,3,4,7,8,9)	X	5.52	72.31	19.02	2.23	80.0	± 9.6 %
		Y	5.35	70.96	18.38		80.0	
		Z	4.99	71.02	18.34		80.0	
10509-AAA	LTE-TDD (SC-FDMA, 100% RB, 15 MHz, QPSK, UL Subframe=2,3,4,7,8,9)	X	6.86	76.40	20.08	2.23	80.0	± 9.6 %
		Y	6.23	74.05	19.09		80.0	
		Z	5.83	74.13	19.18		80.0	
10510-AAA	LTE-TDD (SC-FDMA, 100% RB, 15 MHz, 16-QAM, UL Subframe=2,3,4,7,8,9)	X	5.89	72.04	18.91	2.23	80.0	± 9.6 %
		Y	5.75	70.91	18.36		80.0	
		Z	5.36	70.80	18.32		80.0	
10511-AAA	LTE-TDD (SC-FDMA, 100% RB, 15 MHz, 64-QAM, UL Subframe=2,3,4,7,8,9)	X	5.86	71.58	18.77	2.23	80.0	± 9.6 %
		Y	5.75	70.55	18.27		80.0	
		Z	5.39	70.48	18.23		80.0	
10512-AAA	LTE-TDD (SC-FDMA, 100% RB, 20 MHz, QPSK, UL Subframe=2,3,4,7,8,9)	X	7.85	79.24	20.97	2.23	80.0	± 9.6 %
		Y	6.75	76.04	19.69		80.0	
		Z	6.30	76.05	19.77		80.0	
10513-AAA	LTE-TDD (SC-FDMA, 100% RB, 20 MHz, 16-QAM, UL Subframe=2,3,4,7,8,9)	X	5.88	72.72	19.16	2.23	80.0	± 9.6 %
		Y	5.70	71.43	18.55		80.0	
		Z	5.29	71.21	18.47		80.0	
10514-AAA	LTE-TDD (SC-FDMA, 100% RB, 20 MHz, 64-QAM, UL Subframe=2,3,4,7,8,9)	X	5.77	72.00	18.94	2.23	80.0	± 9.6 %
		Y	5.64	70.86	18.38		80.0	
		Z	5.26	70.69	18.32		80.0	
10515-AAA	IEEE 802.11b WiFi 2.4 GHz (DSSS, 2 Mbps, 99pc duty cycle)	X	1.03	64.88	16.19	0.00	150.0	± 9.6 %
		Y	0.99	63.07	14.62		150.0	
		Z	0.99	63.20	14.56		150.0	
10516-AAA	IEEE 802.11b WiFi 2.4 GHz (DSSS, 5.5 Mbps, 99pc duty cycle)	X	1.64	91.04	26.85	0.00	150.0	± 9.6 %
		Y	0.59	69.22	16.60		150.0	
		Z	0.59	69.23	16.57		150.0	
10517-AAA	IEEE 802.11b WiFi 2.4 GHz (DSSS, 11 Mbps, 99pc duty cycle)	X	0.96	68.68	17.89	0.00	150.0	± 9.6 %
		Y	0.84	64.94	15.18		150.0	
		Z	0.84	64.94	15.09		150.0	
10518-AAA	IEEE 802.11a/h WiFi 5 GHz (OFDM, 9 Mbps, 99pc duty cycle)	X	4.73	67.22	16.54	0.00	150.0	± 9.6 %
		Y	4.75	66.79	16.24		150.0	
		Z	4.57	66.91	16.20		150.0	
10519-AAA	IEEE 802.11a/h WiFi 5 GHz (OFDM, 12 Mbps, 99pc duty cycle)	X	4.96	67.51	16.67	0.00	150.0	± 9.6 %
		Y	4.99	67.12	16.39		150.0	
		Z	4.76	67.15	16.33		150.0	
10520-AAA	IEEE 802.11a/h WiFi 5 GHz (OFDM, 18 Mbps, 99pc duty cycle)	X	4.82	67.52	16.62	0.00	150.0	± 9.6 %
		Y	4.84	67.09	16.32		150.0	
		Z	4.61	67.11	16.25		150.0	
10521-AAA	IEEE 802.11a/h WiFi 5 GHz (OFDM, 24 Mbps, 99pc duty cycle)	X	4.75	67.54	16.61	0.00	150.0	± 9.6 %
		Y	4.77	67.10	16.31		150.0	
		Z	4.54	67.10	16.23		150.0	
10522-AAA	IEEE 802.11a/h WiFi 5 GHz (OFDM, 36 Mbps, 99pc duty cycle)	X	4.79	67.47	16.62	0.00	150.0	± 9.6 %
		Y	4.80	67.00	16.30		150.0	
		Z	4.60	67.19	16.31		150.0	

10523-AAA	IEEE 802.11a/h WiFi 5 GHz (OFDM, 48 Mbps, 99pc duty cycle)	X	4.66	67.41	16.50	0.00	150.0	± 9.6 %
		Y	4.67	66.95	16.18		150.0	
		Z	4.48	67.04	16.16		150.0	
10524-AAA	IEEE 802.11a/h WiFi 5 GHz (OFDM, 54 Mbps, 99pc duty cycle)	X	4.74	67.44	16.62	0.00	150.0	± 9.6 %
		Y	4.76	66.99	16.31		150.0	
		Z	4.54	67.10	16.28		150.0	
10525-AAA	IEEE 802.11ac WiFi (20MHz, MCS0, 99pc duty cycle)	X	4.69	66.48	16.21	0.00	150.0	± 9.6 %
		Y	4.70	66.02	15.89		150.0	
		Z	4.53	66.15	15.87		150.0	
10526-AAA	IEEE 802.11ac WiFi (20MHz, MCS1, 99pc duty cycle)	X	4.91	66.90	16.35	0.00	150.0	± 9.6 %
		Y	4.91	66.43	16.04		150.0	
		Z	4.70	66.52	16.01		150.0	
10527-AAA	IEEE 802.11ac WiFi (20MHz, MCS2, 99pc duty cycle)	X	4.82	66.89	16.32	0.00	150.0	± 9.6 %
		Y	4.83	66.42	16.00		150.0	
		Z	4.62	66.47	15.95		150.0	
10528-AAA	IEEE 802.11ac WiFi (20MHz, MCS3, 99pc duty cycle)	X	4.84	66.91	16.35	0.00	150.0	± 9.6 %
		Y	4.85	66.44	16.03		150.0	
		Z	4.63	66.49	15.99		150.0	
10529-AAA	IEEE 802.11ac WiFi (20MHz, MCS4, 99pc duty cycle)	X	4.84	66.91	16.35	0.00	150.0	± 9.6 %
		Y	4.85	66.44	16.03		150.0	
		Z	4.63	66.49	15.99		150.0	
10531-AAA	IEEE 802.11ac WiFi (20MHz, MCS6, 99pc duty cycle)	X	4.86	67.08	16.39	0.00	150.0	± 9.6 %
		Y	4.87	66.60	16.06		150.0	
		Z	4.63	66.60	16.00		150.0	
10532-AAA	IEEE 802.11ac WiFi (20MHz, MCS7, 99pc duty cycle)	X	4.71	66.97	16.35	0.00	150.0	± 9.6 %
		Y	4.72	66.49	16.02		150.0	
		Z	4.49	66.45	15.93		150.0	
10533-AAA	IEEE 802.11ac WiFi (20MHz, MCS8, 99pc duty cycle)	X	4.86	66.93	16.33	0.00	150.0	± 9.6 %
		Y	4.87	66.45	16.01		150.0	
		Z	4.64	66.54	15.97		150.0	
10534-AAA	IEEE 802.11ac WiFi (40MHz, MCS0, 99pc duty cycle)	X	5.34	67.03	16.36	0.00	150.0	± 9.6 %
		Y	5.36	66.66	16.11		150.0	
		Z	5.17	66.62	16.06		150.0	
10535-AAA	IEEE 802.11ac WiFi (40MHz, MCS1, 99pc duty cycle)	X	5.42	67.17	16.42	0.00	150.0	± 9.6 %
		Y	5.43	66.80	16.16		150.0	
		Z	5.24	66.80	16.14		150.0	
10536-AAA	IEEE 802.11ac WiFi (40MHz, MCS2, 99pc duty cycle)	X	5.29	67.18	16.41	0.00	150.0	± 9.6 %
		Y	5.30	66.78	16.13		150.0	
		Z	5.11	66.74	16.09		150.0	
10537-AAA	IEEE 802.11ac WiFi (40MHz, MCS3, 99pc duty cycle)	X	5.35	67.14	16.39	0.00	150.0	± 9.6 %
		Y	5.36	66.75	16.12		150.0	
		Z	5.16	66.71	16.08		150.0	
10538-AAA	IEEE 802.11ac WiFi (40MHz, MCS4, 99pc duty cycle)	X	5.47	67.20	16.46	0.00	150.0	± 9.6 %
		Y	5.49	66.85	16.21		150.0	
		Z	5.26	66.74	16.13		150.0	
10540-AAA	IEEE 802.11ac WiFi (40MHz, MCS6, 99pc duty cycle)	X	5.36	67.15	16.45	0.00	150.0	± 9.6 %
		Y	5.38	66.77	16.18		150.0	
		Z	5.19	66.76	16.16		150.0	

10541-AAA	IEEE 802.11ac WiFi (40MHz, MCS7, 99pc duty cycle)	X	5.35	67.08	16.42	0.00	150.0	± 9.6 %
		Y	5.38	66.75	16.17		150.0	
		Z	5.16	66.62	16.08		150.0	
10542-AAA	IEEE 802.11ac WiFi (40MHz, MCS8, 99pc duty cycle)	X	5.49	67.08	16.42	0.00	150.0	± 9.6 %
		Y	5.51	66.73	16.18		150.0	
		Z	5.31	66.69	16.13		150.0	
10543-AAA	IEEE 802.11ac WiFi (40MHz, MCS9, 99pc duty cycle)	X	5.58	67.09	16.44	0.00	150.0	± 9.6 %
		Y	5.61	66.77	16.21		150.0	
		Z	5.39	66.74	16.17		150.0	
10544-AAA	IEEE 802.11ac WiFi (80MHz, MCS0, 99pc duty cycle)	X	5.61	67.12	16.33	0.00	150.0	± 9.6 %
		Y	5.62	66.77	16.09		150.0	
		Z	5.48	66.74	16.05		150.0	
10545-AAA	IEEE 802.11ac WiFi (80MHz, MCS1, 99pc duty cycle)	X	5.83	67.51	16.46	0.00	150.0	± 9.6 %
		Y	5.84	67.15	16.22		150.0	
		Z	5.68	67.16	16.22		150.0	
10546-AAA	IEEE 802.11ac WiFi (80MHz, MCS2, 99pc duty cycle)	X	5.72	67.42	16.44	0.00	150.0	± 9.6 %
		Y	5.73	67.08	16.20		150.0	
		Z	5.55	66.95	16.13		150.0	
10547-AAA	IEEE 802.11ac WiFi (80MHz, MCS3, 99pc duty cycle)	X	5.81	67.48	16.46	0.00	150.0	± 9.6 %
		Y	5.83	67.17	16.24		150.0	
		Z	5.62	66.99	16.14		150.0	
10548-AAA	IEEE 802.11ac WiFi (80MHz, MCS4, 99pc duty cycle)	X	6.10	68.50	16.94	0.00	150.0	± 9.6 %
		Y	6.15	68.24	16.74		150.0	
		Z	5.89	67.98	16.61		150.0	
10550-AAA	IEEE 802.11ac WiFi (80MHz, MCS6, 99pc duty cycle)	X	5.74	67.36	16.42	0.00	150.0	± 9.6 %
		Y	5.75	67.01	16.18		150.0	
		Z	5.57	66.96	16.14		150.0	
10551-AAA	IEEE 802.11ac WiFi (80MHz, MCS7, 99pc duty cycle)	X	5.76	67.47	16.43	0.00	150.0	± 9.6 %
		Y	5.78	67.14	16.20		150.0	
		Z	5.58	67.00	16.12		150.0	
10552-AAA	IEEE 802.11ac WiFi (80MHz, MCS8, 99pc duty cycle)	X	5.66	67.23	16.33	0.00	150.0	± 9.6 %
		Y	5.67	66.89	16.10		150.0	
		Z	5.49	66.80	16.03		150.0	
10553-AAA	IEEE 802.11ac WiFi (80MHz, MCS9, 99pc duty cycle)	X	5.75	67.26	16.37	0.00	150.0	± 9.6 %
		Y	5.76	66.93	16.14		150.0	
		Z	5.58	66.84	16.08		150.0	
10554-AAA	IEEE 1602.11ac WiFi (160MHz, MCS0, 99pc duty cycle)	X	6.01	67.49	16.42	0.00	150.0	± 9.6 %
		Y	6.02	67.17	16.20		150.0	
		Z	5.89	67.10	16.15		150.0	
10555-AAA	IEEE 1602.11ac WiFi (160MHz, MCS1, 99pc duty cycle)	X	6.17	67.85	16.56	0.00	150.0	± 9.6 %
		Y	6.20	67.56	16.36		150.0	
		Z	6.02	67.41	16.28		150.0	
10556-AAA	IEEE 1602.11ac WiFi (160MHz, MCS2, 99pc duty cycle)	X	6.18	67.83	16.55	0.00	150.0	± 9.6 %
		Y	6.19	67.51	16.33		150.0	
		Z	6.04	67.46	16.30		150.0	
10557-AAA	IEEE 1602.11ac WiFi (160MHz, MCS3, 99pc duty cycle)	X	6.17	67.82	16.57	0.00	150.0	± 9.6 %
		Y	6.19	67.52	16.36		150.0	
		Z	6.00	67.36	16.27		150.0	

10558-AAA	IEEE 1602.11ac WiFi (160MHz, MCS4, 99pc duty cycle)	X	6.23	68.01	16.68	0.00	150.0	± 9.6 %
		Y	6.25	67.72	16.47		150.0	
		Z	6.05	67.53	16.37		150.0	
10560-AAA	IEEE 1602.11ac WiFi (160MHz, MCS6, 99pc duty cycle)	X	6.22	67.85	16.63	0.00	150.0	± 9.6 %
		Y	6.25	67.56	16.43		150.0	
		Z	6.05	67.37	16.33		150.0	
10561-AAA	IEEE 1602.11ac WiFi (160MHz, MCS7, 99pc duty cycle)	X	6.13	67.79	16.64	0.00	150.0	± 9.6 %
		Y	6.15	67.49	16.43		150.0	
		Z	5.97	67.35	16.35		150.0	
10562-AAA	IEEE 1602.11ac WiFi (160MHz, MCS8, 99pc duty cycle)	X	6.29	68.28	16.89	0.00	150.0	± 9.6 %
		Y	6.33	68.01	16.70		150.0	
		Z	6.10	67.74	16.55		150.0	
10563-AAA	IEEE 1602.11ac WiFi (160MHz, MCS9, 99pc duty cycle)	X	6.57	68.63	17.00	0.00	150.0	± 9.6 %
		Y	6.57	68.27	16.77		150.0	
		Z	6.35	68.10	16.68		150.0	
10564-AAA	IEEE 802.11g WiFi 2.4 GHz (DSSS-OFDM, 9 Mbps, 99pc duty cycle)	X	5.07	67.31	16.69	0.46	150.0	± 9.6 %
		Y	5.10	66.95	16.44		150.0	
		Z	4.91	67.04	16.40		150.0	
10565-AAA	IEEE 802.11g WiFi 2.4 GHz (DSSS-OFDM, 12 Mbps, 99pc duty cycle)	X	5.34	67.80	17.01	0.46	150.0	± 9.6 %
		Y	5.38	67.46	16.78		150.0	
		Z	5.14	67.47	16.71		150.0	
10566-AAA	IEEE 802.11g WiFi 2.4 GHz (DSSS-OFDM, 18 Mbps, 99pc duty cycle)	X	5.17	67.69	16.85	0.46	150.0	± 9.6 %
		Y	5.21	67.33	16.61		150.0	
		Z	4.97	67.33	16.54		150.0	
10567-AAA	IEEE 802.11g WiFi 2.4 GHz (DSSS-OFDM, 24 Mbps, 99pc duty cycle)	X	5.20	68.09	17.20	0.46	150.0	± 9.6 %
		Y	5.23	67.71	16.94		150.0	
		Z	5.00	67.68	16.86		150.0	
10568-AAA	IEEE 802.11g WiFi 2.4 GHz (DSSS-OFDM, 36 Mbps, 99pc duty cycle)	X	5.08	67.38	16.59	0.46	150.0	± 9.6 %
		Y	5.11	67.01	16.33		150.0	
		Z	4.90	67.16	16.34		150.0	
10569-AAA	IEEE 802.11g WiFi 2.4 GHz (DSSS-OFDM, 48 Mbps, 99pc duty cycle)	X	5.14	68.11	17.22	0.46	150.0	± 9.6 %
		Y	5.16	67.71	16.95		150.0	
		Z	4.96	67.77	16.91		150.0	
10570-AAA	IEEE 802.11g WiFi 2.4 GHz (DSSS-OFDM, 54 Mbps, 99pc duty cycle)	X	5.18	67.92	17.15	0.46	150.0	± 9.6 %
		Y	5.21	67.52	16.88		150.0	
		Z	4.99	67.63	16.86		150.0	
10571-AAA	IEEE 802.11b WiFi 2.4 GHz (DSSS, 1 Mbps, 90pc duty cycle)	X	1.45	67.97	17.69	0.46	130.0	± 9.6 %
		Y	1.38	65.84	16.15		130.0	
		Z	1.34	65.80	16.05		130.0	
10572-AAA	IEEE 802.11b WiFi 2.4 GHz (DSSS, 2 Mbps, 90pc duty cycle)	X	1.49	68.86	18.18	0.46	130.0	± 9.6 %
		Y	1.40	66.47	16.51		130.0	
		Z	1.36	66.39	16.40		130.0	
10573-AAA	IEEE 802.11b WiFi 2.4 GHz (DSSS, 5.5 Mbps, 90pc duty cycle)	X	100.00	149.30	40.22	0.46	130.0	± 9.6 %
		Y	3.11	88.03	23.54		130.0	
		Z	3.23	89.37	24.00		130.0	
10574-AAA	IEEE 802.11b WiFi 2.4 GHz (DSSS, 11 Mbps, 90pc duty cycle)	X	2.21	80.01	23.13	0.46	130.0	± 9.6 %
		Y	1.65	72.75	19.44		130.0	
		Z	1.56	72.33	19.21		130.0	

10575-AAA	IEEE 802.11g WiFi 2.4 GHz (DSSS-OFDM, 6 Mbps, 90pc duty cycle)	X	4.88	67.15	16.77	0.46	130.0	± 9.6 %
		Y	4.92	66.81	16.54		130.0	
		Z	4.73	66.93	16.51		130.0	
10576-AAA	IEEE 802.11g WiFi 2.4 GHz (DSSS-OFDM, 9 Mbps, 90pc duty cycle)	X	4.91	67.32	16.84	0.46	130.0	± 9.6 %
		Y	4.94	66.97	16.61		130.0	
		Z	4.75	67.08	16.56		130.0	
10577-AAA	IEEE 802.11g WiFi 2.4 GHz (DSSS-OFDM, 12 Mbps, 90pc duty cycle)	X	5.15	67.65	17.01	0.46	130.0	± 9.6 %
		Y	5.20	67.33	16.79		130.0	
		Z	4.96	67.36	16.73		130.0	
10578-AAA	IEEE 802.11g WiFi 2.4 GHz (DSSS-OFDM, 18 Mbps, 90pc duty cycle)	X	5.05	67.86	17.13	0.46	130.0	± 9.6 %
		Y	5.09	67.50	16.89		130.0	
		Z	4.85	67.51	16.82		130.0	
10579-AAA	IEEE 802.11g WiFi 2.4 GHz (DSSS-OFDM, 24 Mbps, 90pc duty cycle)	X	4.82	67.24	16.51	0.46	130.0	± 9.6 %
		Y	4.87	66.90	16.27		130.0	
		Z	4.63	66.89	16.19		130.0	
10580-AAA	IEEE 802.11g WiFi 2.4 GHz (DSSS-OFDM, 36 Mbps, 90pc duty cycle)	X	4.86	67.17	16.48	0.46	130.0	± 9.6 %
		Y	4.91	66.83	16.25		130.0	
		Z	4.68	66.92	16.22		130.0	
10581-AAA	IEEE 802.11g WiFi 2.4 GHz (DSSS-OFDM, 48 Mbps, 90pc duty cycle)	X	4.96	67.97	17.11	0.46	130.0	± 9.6 %
		Y	5.00	67.61	16.86		130.0	
		Z	4.76	67.57	16.77		130.0	
10582-AAA	IEEE 802.11g WiFi 2.4 GHz (DSSS-OFDM, 54 Mbps, 90pc duty cycle)	X	4.78	66.97	16.29	0.46	130.0	± 9.6 %
		Y	4.83	66.64	16.06		130.0	
		Z	4.58	66.67	16.00		130.0	
10583-AAA	IEEE 802.11a/h WiFi 5 GHz (OFDM, 6 Mbps, 90pc duty cycle)	X	4.88	67.15	16.77	0.46	130.0	± 9.6 %
		Y	4.92	66.81	16.54		130.0	
		Z	4.73	66.93	16.51		130.0	
10584-AAA	IEEE 802.11a/h WiFi 5 GHz (OFDM, 9 Mbps, 90pc duty cycle)	X	4.91	67.32	16.84	0.46	130.0	± 9.6 %
		Y	4.94	66.97	16.61		130.0	
		Z	4.75	67.08	16.56		130.0	
10585-AAA	IEEE 802.11a/h WiFi 5 GHz (OFDM, 12 Mbps, 90pc duty cycle)	X	5.15	67.65	17.01	0.46	130.0	± 9.6 %
		Y	5.20	67.33	16.79		130.0	
		Z	4.96	67.36	16.73		130.0	
10586-AAA	IEEE 802.11a/h WiFi 5 GHz (OFDM, 18 Mbps, 90pc duty cycle)	X	5.05	67.86	17.13	0.46	130.0	± 9.6 %
		Y	5.09	67.50	16.89		130.0	
		Z	4.85	67.51	16.82		130.0	
10587-AAA	IEEE 802.11a/h WiFi 5 GHz (OFDM, 24 Mbps, 90pc duty cycle)	X	4.82	67.24	16.51	0.46	130.0	± 9.6 %
		Y	4.87	66.90	16.27		130.0	
		Z	4.63	66.89	16.19		130.0	
10588-AAA	IEEE 802.11a/h WiFi 5 GHz (OFDM, 36 Mbps, 90pc duty cycle)	X	4.86	67.17	16.48	0.46	130.0	± 9.6 %
		Y	4.91	66.83	16.25		130.0	
		Z	4.68	66.92	16.22		130.0	
10589-AAA	IEEE 802.11a/h WiFi 5 GHz (OFDM, 48 Mbps, 90pc duty cycle)	X	4.96	67.97	17.11	0.46	130.0	± 9.6 %
		Y	5.00	67.61	16.86		130.0	
		Z	4.76	67.57	16.77		130.0	
10590-AAA	IEEE 802.11a/h WiFi 5 GHz (OFDM, 54 Mbps, 90pc duty cycle)	X	4.78	66.97	16.29	0.46	130.0	± 9.6 %
		Y	4.83	66.64	16.06		130.0	
		Z	4.58	66.67	16.00		130.0	

10591-AAA	IEEE 802.11n (HT Mixed, 20MHz, MCS0, 90pc duty cycle)	X	5.03	67.20	16.86	0.46	130.0	± 9.6 %
		Y	5.07	66.88	16.64		130.0	
		Z	4.88	66.97	16.60		130.0	
10592-AAA	IEEE 802.11n (HT Mixed, 20MHz, MCS1, 90pc duty cycle)	X	5.21	67.55	16.98	0.46	130.0	± 9.6 %
		Y	5.26	67.23	16.76		130.0	
		Z	5.03	67.30	16.73		130.0	
10593-AAA	IEEE 802.11n (HT Mixed, 20MHz, MCS2, 90pc duty cycle)	X	5.14	67.52	16.89	0.46	130.0	± 9.6 %
		Y	5.19	67.20	16.68		130.0	
		Z	4.96	67.23	16.62		130.0	
10594-AAA	IEEE 802.11n (HT Mixed, 20MHz, MCS3, 90pc duty cycle)	X	5.19	67.66	17.03	0.46	130.0	± 9.6 %
		Y	5.24	67.33	16.81		130.0	
		Z	5.01	67.38	16.76		130.0	
10595-AAA	IEEE 802.11n (HT Mixed, 20MHz, MCS4, 90pc duty cycle)	X	5.17	67.65	16.95	0.46	130.0	± 9.6 %
		Y	5.23	67.33	16.73		130.0	
		Z	4.98	67.35	16.67		130.0	
10596-AAA	IEEE 802.11n (HT Mixed, 20MHz, MCS5, 90pc duty cycle)	X	5.11	67.64	16.94	0.46	130.0	± 9.6 %
		Y	5.16	67.30	16.71		130.0	
		Z	4.92	67.35	16.67		130.0	
10597-AAA	IEEE 802.11n (HT Mixed, 20MHz, MCS6, 90pc duty cycle)	X	5.06	67.59	16.86	0.46	130.0	± 9.6 %
		Y	5.11	67.26	16.64		130.0	
		Z	4.87	67.26	16.56		130.0	
10598-AAA	IEEE 802.11n (HT Mixed, 20MHz, MCS7, 90pc duty cycle)	X	5.05	67.87	17.14	0.46	130.0	± 9.6 %
		Y	5.09	67.53	16.91		130.0	
		Z	4.85	67.47	16.80		130.0	
10599-AAA	IEEE 802.11n (HT Mixed, 40MHz, MCS0, 90pc duty cycle)	X	5.68	67.76	17.01	0.46	130.0	± 9.6 %
		Y	5.74	67.54	16.84		130.0	
		Z	5.54	67.51	16.80		130.0	
10600-AAA	IEEE 802.11n (HT Mixed, 40MHz, MCS1, 90pc duty cycle)	X	5.91	68.42	17.31	0.46	130.0	± 9.6 %
		Y	6.00	68.29	17.19		130.0	
		Z	5.69	67.96	17.01		130.0	
10601-AAA	IEEE 802.11n (HT Mixed, 40MHz, MCS2, 90pc duty cycle)	X	5.75	68.03	17.13	0.46	130.0	± 9.6 %
		Y	5.81	67.81	16.96		130.0	
		Z	5.57	67.70	16.89		130.0	
10602-AAA	IEEE 802.11n (HT Mixed, 40MHz, MCS3, 90pc duty cycle)	X	5.85	68.05	17.05	0.46	130.0	± 9.6 %
		Y	5.93	67.91	16.93		130.0	
		Z	5.67	67.73	16.83		130.0	
10603-AAA	IEEE 802.11n (HT Mixed, 40MHz, MCS4, 90pc duty cycle)	X	5.97	68.46	17.38	0.46	130.0	± 9.6 %
		Y	6.05	68.29	17.25		130.0	
		Z	5.74	68.01	17.09		130.0	
10604-AAA	IEEE 802.11n (HT Mixed, 40MHz, MCS5, 90pc duty cycle)	X	5.70	67.75	17.03	0.46	130.0	± 9.6 %
		Y	5.76	67.53	16.86		130.0	
		Z	5.55	67.48	16.81		130.0	
10605-AAA	IEEE 802.11n (HT Mixed, 40MHz, MCS6, 90pc duty cycle)	X	5.80	68.03	17.16	0.46	130.0	± 9.6 %
		Y	5.86	67.81	17.00		130.0	
		Z	5.67	67.84	17.00		130.0	
10606-AAA	IEEE 802.11n (HT Mixed, 40MHz, MCS7, 90pc duty cycle)	X	5.58	67.53	16.79	0.46	130.0	± 9.6 %
		Y	5.62	67.26	16.60		130.0	
		Z	5.41	67.19	16.54		130.0	

10607-AAA	IEEE 802.11ac WiFi (20MHz, MCS0, 90pc duty cycle)	X	4.86	66.52	16.48	0.46	130.0	± 9.6 %
		Y	4.89	66.14	16.23		130.0	
		Z	4.71	66.27	16.21		130.0	
10608-AAA	IEEE 802.11ac WiFi (20MHz, MCS1, 90pc duty cycle)	X	5.09	66.96	16.64	0.46	130.0	± 9.6 %
		Y	5.12	66.58	16.39		130.0	
		Z	4.90	66.67	16.37		130.0	
10609-AAA	IEEE 802.11ac WiFi (20MHz, MCS2, 90pc duty cycle)	X	4.98	66.85	16.52	0.46	130.0	± 9.6 %
		Y	5.01	66.47	16.26		130.0	
		Z	4.79	66.53	16.22		130.0	
10610-AAA	IEEE 802.11ac WiFi (20MHz, MCS3, 90pc duty cycle)	X	5.03	67.01	16.67	0.46	130.0	± 9.6 %
		Y	5.06	66.63	16.42		130.0	
		Z	4.84	66.68	16.37		130.0	
10611-AAA	IEEE 802.11ac WiFi (20MHz, MCS4, 90pc duty cycle)	X	4.96	66.86	16.54	0.46	130.0	± 9.6 %
		Y	4.99	66.50	16.29		130.0	
		Z	4.76	66.50	16.23		130.0	
10612-AAA	IEEE 802.11ac WiFi (20MHz, MCS5, 90pc duty cycle)	X	4.97	67.00	16.58	0.46	130.0	± 9.6 %
		Y	5.01	66.61	16.31		130.0	
		Z	4.77	66.66	16.28		130.0	
10613-AAA	IEEE 802.11ac WiFi (20MHz, MCS6, 90pc duty cycle)	X	4.99	66.94	16.49	0.46	130.0	± 9.6 %
		Y	5.03	66.55	16.23		130.0	
		Z	4.77	66.56	16.17		130.0	
10614-AAA	IEEE 802.11ac WiFi (20MHz, MCS7, 90pc duty cycle)	X	4.92	67.15	16.73	0.46	130.0	± 9.6 %
		Y	4.95	66.76	16.47		130.0	
		Z	4.71	66.71	16.38		130.0	
10615-AAA	IEEE 802.11ac WiFi (20MHz, MCS8, 90pc duty cycle)	X	4.95	66.65	16.31	0.46	130.0	± 9.6 %
		Y	4.99	66.28	16.06		130.0	
		Z	4.76	66.36	16.03		130.0	
10616-AAA	IEEE 802.11ac WiFi (40MHz, MCS0, 90pc duty cycle)	X	5.51	67.07	16.65	0.46	130.0	± 9.6 %
		Y	5.55	66.78	16.45		130.0	
		Z	5.35	66.74	16.40		130.0	
10617-AAA	IEEE 802.11ac WiFi (40MHz, MCS1, 90pc duty cycle)	X	5.58	67.18	16.67	0.46	130.0	± 9.6 %
		Y	5.62	66.89	16.46		130.0	
		Z	5.43	66.92	16.46		130.0	
10618-AAA	IEEE 802.11ac WiFi (40MHz, MCS2, 90pc duty cycle)	X	5.47	67.27	16.74	0.46	130.0	± 9.6 %
		Y	5.50	66.95	16.52		130.0	
		Z	5.31	66.92	16.47		130.0	
10619-AAA	IEEE 802.11ac WiFi (40MHz, MCS3, 90pc duty cycle)	X	5.49	67.07	16.57	0.46	130.0	± 9.6 %
		Y	5.52	66.76	16.36		130.0	
		Z	5.33	66.76	16.33		130.0	
10620-AAA	IEEE 802.11ac WiFi (40MHz, MCS4, 90pc duty cycle)	X	5.62	67.19	16.68	0.46	130.0	± 9.6 %
		Y	5.67	66.93	16.49		130.0	
		Z	5.42	66.79	16.40		130.0	
10621-AAA	IEEE 802.11ac WiFi (40MHz, MCS5, 90pc duty cycle)	X	5.59	67.25	16.82	0.46	130.0	± 9.6 %
		Y	5.63	66.98	16.62		130.0	
		Z	5.41	66.88	16.56		130.0	
10622-AAA	IEEE 802.11ac WiFi (40MHz, MCS6, 90pc duty cycle)	X	5.58	67.35	16.86	0.46	130.0	± 9.6 %
		Y	5.62	67.06	16.66		130.0	
		Z	5.43	67.06	16.64		130.0	

10623-AAA	IEEE 802.11ac WiFi (40MHz, MCS7, 90pc duty cycle)	X	5.48	66.99	16.57	0.46	130.0	± 9.6 %
		Y	5.54	66.75	16.40		130.0	
		Z	5.31	66.61	16.29		130.0	
10624-AAA	IEEE 802.11ac WiFi (40MHz, MCS8, 90pc duty cycle)	X	5.65	67.09	16.68	0.46	130.0	± 9.6 %
		Y	5.69	66.81	16.49		130.0	
		Z	5.50	66.79	16.45		130.0	
10625-AAA	IEEE 802.11ac WiFi (40MHz, MCS9, 90pc duty cycle)	X	6.03	68.01	17.18	0.46	130.0	± 9.6 %
		Y	6.05	67.65	16.95		130.0	
		Z	5.88	67.81	17.01		130.0	
10626-AAA	IEEE 802.11ac WiFi (80MHz, MCS0, 90pc duty cycle)	X	5.76	67.09	16.57	0.46	130.0	± 9.6 %
		Y	5.79	66.81	16.38		130.0	
		Z	5.64	66.79	16.35		130.0	
10627-AAA	IEEE 802.11ac WiFi (80MHz, MCS1, 90pc duty cycle)	X	6.01	67.60	16.77	0.46	130.0	± 9.6 %
		Y	6.04	67.32	16.58		130.0	
		Z	5.89	67.37	16.60		130.0	
10628-AAA	IEEE 802.11ac WiFi (80MHz, MCS2, 90pc duty cycle)	X	5.83	67.28	16.56	0.46	130.0	± 9.6 %
		Y	5.87	67.01	16.37		130.0	
		Z	5.69	66.92	16.32		130.0	
10629-AAA	IEEE 802.11ac WiFi (80MHz, MCS3, 90pc duty cycle)	X	5.93	67.36	16.58	0.46	130.0	± 9.6 %
		Y	5.99	67.16	16.43		130.0	
		Z	5.77	67.00	16.35		130.0	
10630-AAA	IEEE 802.11ac WiFi (80MHz, MCS4, 90pc duty cycle)	X	6.47	69.11	17.45	0.46	130.0	± 9.6 %
		Y	6.56	68.99	17.34		130.0	
		Z	6.24	68.58	17.14		130.0	
10631-AAA	IEEE 802.11ac WiFi (80MHz, MCS5, 90pc duty cycle)	X	6.36	68.89	17.53	0.46	130.0	± 9.6 %
		Y	6.44	68.71	17.39		130.0	
		Z	6.09	68.24	17.15		130.0	
10632-AAA	IEEE 802.11ac WiFi (80MHz, MCS6, 90pc duty cycle)	X	6.00	67.73	16.97	0.46	130.0	± 9.6 %
		Y	6.05	67.48	16.79		130.0	
		Z	5.85	67.39	16.74		130.0	
10633-AAA	IEEE 802.11ac WiFi (80MHz, MCS7, 90pc duty cycle)	X	5.95	67.59	16.73	0.46	130.0	± 9.6 %
		Y	6.01	67.38	16.58		130.0	
		Z	5.74	67.05	16.41		130.0	
10634-AAA	IEEE 802.11ac WiFi (80MHz, MCS8, 90pc duty cycle)	X	5.92	67.56	16.78	0.46	130.0	± 9.6 %
		Y	5.98	67.34	16.62		130.0	
		Z	5.72	67.07	16.47		130.0	
10635-AAA	IEEE 802.11ac WiFi (80MHz, MCS9, 90pc duty cycle)	X	5.80	66.87	16.18	0.46	130.0	± 9.6 %
		Y	5.85	66.64	16.01		130.0	
		Z	5.62	66.48	15.93		130.0	
10636-AAA	IEEE 1602.11ac WiFi (160MHz, MCS0, 90pc duty cycle)	X	6.16	67.47	16.65	0.46	130.0	± 9.6 %
		Y	6.19	67.22	16.49		130.0	
		Z	6.06	67.16	16.44		130.0	
10637-AAA	IEEE 1602.11ac WiFi (160MHz, MCS1, 90pc duty cycle)	X	6.34	67.89	16.84	0.46	130.0	± 9.6 %
		Y	6.39	67.69	16.69		130.0	
		Z	6.22	67.55	16.62		130.0	
10638-AAA	IEEE 1602.11ac WiFi (160MHz, MCS2, 90pc duty cycle)	X	6.33	67.82	16.78	0.46	130.0	± 9.6 %
		Y	6.36	67.57	16.61		130.0	
		Z	6.21	67.52	16.58		130.0	

10639-AAA	IEEE 1602.11ac WiFi (160MHz, MCS3, 90pc duty cycle)	X	6.34	67.88	16.86	0.46	130.0	± 9.6 %
		Y	6.38	67.64	16.70		130.0	
		Z	6.19	67.47	16.60		130.0	
10640-AAA	IEEE 1602.11ac WiFi (160MHz, MCS4, 90pc duty cycle)	X	6.37	67.96	16.84	0.46	130.0	± 9.6 %
		Y	6.42	67.75	16.69		130.0	
		Z	6.20	67.51	16.57		130.0	
10641-AAA	IEEE 1602.11ac WiFi (160MHz, MCS5, 90pc duty cycle)	X	6.36	67.66	16.71	0.46	130.0	± 9.6 %
		Y	6.40	67.44	16.56		130.0	
		Z	6.24	67.40	16.53		130.0	
10642-AAA	IEEE 1602.11ac WiFi (160MHz, MCS6, 90pc duty cycle)	X	6.44	68.03	17.05	0.46	130.0	± 9.6 %
		Y	6.49	67.81	16.91		130.0	
		Z	6.28	67.62	16.80		130.0	
10643-AAA	IEEE 1602.11ac WiFi (160MHz, MCS7, 90pc duty cycle)	X	6.26	67.70	16.80	0.46	130.0	± 9.6 %
		Y	6.31	67.48	16.64		130.0	
		Z	6.12	67.34	16.57		130.0	
10644-AAA	IEEE 1602.11ac WiFi (160MHz, MCS8, 90pc duty cycle)	X	6.50	68.41	17.18	0.46	130.0	± 9.6 %
		Y	6.57	68.25	17.05		130.0	
		Z	6.29	67.86	16.85		130.0	
10645-AAA	IEEE 1602.11ac WiFi (160MHz, MCS9, 90pc duty cycle)	X	6.78	68.77	17.29	0.46	130.0	± 9.6 %
		Y	6.81	68.48	17.11		130.0	
		Z	6.68	68.60	17.18		130.0	
10646-AAB	LTE-TDD (SC-FDMA, 1 RB, 5 MHz, QPSK, UL Subframe=2,7)	X	37.14	116.21	38.03	9.30	60.0	± 9.6 %
		Y	19.95	100.33	33.06		60.0	
		Z	62.05	131.91	43.22		60.0	
10647-AAA	LTE-TDD (SC-FDMA, 1 RB, 20 MHz, QPSK, UL Subframe=2,7)	X	38.52	117.84	38.64	9.30	60.0	± 9.6 %
		Y	20.25	101.35	33.50		60.0	
		Z	63.43	133.45	43.81		60.0	
10648-AAA	CDMA2000 (1x Advanced)	X	1.03	68.68	14.68	0.00	150.0	± 9.6 %
		Y	0.85	64.54	12.30		150.0	
		Z	0.71	63.65	10.90		150.0	

^E Uncertainty is determined using the max. deviation from linear response applying rectangular distribution and is expressed for the square of the field value.



Accredited by the Swiss Accreditation Service (SAS)
The Swiss Accreditation Service is one of the signatories to the EA
Multilateral Agreement for the recognition of calibration certificates

Accreditation No.: **SCS 0108**

Client **PC Test**

Certificate No: **EX3-7406_Apr16**

CALIBRATION CERTIFICATE

Object: **EX3DV4 - SN:7406**

Calibration procedure(s): **QA CAL-01.v9, QA CAL-23.v5, QA CAL-25.v6**
Calibration procedure for dosimetric E-field probes

Calibration date: **April 19, 2016**

This calibration certificate documents the traceability to national standards, which realize the physical units of measurements (SI).
The measurements and the uncertainties with confidence probability are given on the following pages and are part of the certificate.

All calibrations have been conducted in the closed laboratory facility: environment temperature (22 ± 3)°C and humidity < 70%.

Calibration Equipment used (M&TE critical for calibration)

BN 04/26/2d6 ✓

Primary Standards	ID	Cal Date (Certificate No.)	Scheduled Calibration
Power meter NRP	SN: 104778	06-Apr-16 (No. 217-02288/02289)	Apr-17
Power sensor NRP-Z91	SN: 103244	06-Apr-16 (No. 217-02288)	Apr-17
Power sensor NRP-Z91	SN: 103245	06-Apr-16 (No. 217-02289)	Apr-17
Reference 20 dB Attenuator	SN: S5277 (20x)	05-Apr-16 (No. 217-02293)	Apr-17
Reference Probe ES3DV2	SN: 3013	31-Dec-15 (No. ES3-3013_Dec15)	Dec-16
DAE4	SN: 660	23-Dec-15 (No. DAE4-660_Dec15)	Dec-16
Secondary Standards	ID	Check Date (in house)	Scheduled Check
Power meter E4419B	SN: GB41293874	06-Apr-16 (No. 217-02285/02284)	In house check: Jun-16
Power sensor E4412A	SN: MY41498087	06-Apr-16 (No. 217-02285)	In house check: Jun-16
Power sensor E4412A	SN: 000110210	06-Apr-16 (No. 217-02284)	In house check: Jun-16
RF generator HP 8648C	SN: US3642U01700	04-Aug-99 (in house check Apr-13)	In house check: Jun-16
Network Analyzer HP 8753E	SN: US37390585	18-Oct-01 (in house check Oct-15)	In house check: Oct-16

Calibrated by: **Jeton Kastrati** Name: **Jeton Kastrati** Function: **Laboratory Technician** Signature: *[Signature]*

Approved by: **Katja Pokovic** Name: **Katja Pokovic** Function: **Technical Manager** Signature: *[Signature]*

Issued: April 20, 2016

This calibration certificate shall not be reproduced except in full without written approval of the laboratory.



Accredited by the Swiss Accreditation Service (SAS)

Accreditation No.: **SCS 0108**

The Swiss Accreditation Service is one of the signatories to the EA
Multilateral Agreement for the recognition of calibration certificates

Glossary:

TSL	tissue simulating liquid
NORM _{x,y,z}	sensitivity in free space
ConvF	sensitivity in TSL / NORM _{x,y,z}
DCP	diode compression point
CF	crest factor (1/duty_cycle) of the RF signal
A, B, C, D	modulation dependent linearization parameters
Polarization φ	φ rotation around probe axis
Polarization θ	θ rotation around an axis that is in the plane normal to probe axis (at measurement center), i.e., θ = 0 is normal to probe axis
Connector Angle	information used in DASY system to align probe sensor X to the robot coordinate system

Calibration is Performed According to the Following Standards:

- a) IEEE Std 1528-2013, "IEEE Recommended Practice for Determining the Peak Spatial-Averaged Specific Absorption Rate (SAR) in the Human Head from Wireless Communications Devices: Measurement Techniques", June 2013
- b) IEC 62209-1, "Procedure to measure the Specific Absorption Rate (SAR) for hand-held devices used in close proximity to the ear (frequency range of 300 MHz to 3 GHz)", February 2005
- c) IEC 62209-2, "Procedure to determine the Specific Absorption Rate (SAR) for wireless communication devices used in close proximity to the human body (frequency range of 30 MHz to 6 GHz)", March 2010
- d) KDB 865664, "SAR Measurement Requirements for 100 MHz to 6 GHz"

Methods Applied and Interpretation of Parameters:

- *NORM_{x,y,z}*: Assessed for E-field polarization θ = 0 (f ≤ 900 MHz in TEM-cell; f > 1800 MHz: R22 waveguide). *NORM_{x,y,z}* are only intermediate values, i.e., the uncertainties of *NORM_{x,y,z}* does not affect the E²-field uncertainty inside TSL (see below *ConvF*).
- *NORM(f)_{x,y,z}* = *NORM_{x,y,z}* * *frequency_response* (see Frequency Response Chart). This linearization is implemented in DASY4 software versions later than 4.2. The uncertainty of the frequency response is included in the stated uncertainty of *ConvF*.
- *DCP_{x,y,z}*: DCP are numerical linearization parameters assessed based on the data of power sweep with CW signal (no uncertainty required). DCP does not depend on frequency nor media.
- *PAR*: PAR is the Peak to Average Ratio that is not calibrated but determined based on the signal characteristics
- *A_{x,y,z}*; *B_{x,y,z}*; *C_{x,y,z}*; *D_{x,y,z}*; *VR_{x,y,z}*: *A, B, C, D* are numerical linearization parameters assessed based on the data of power sweep for specific modulation signal. The parameters do not depend on frequency nor media. *VR* is the maximum calibration range expressed in RMS voltage across the diode.
- *ConvF* and *Boundary Effect Parameters*: Assessed in flat phantom using E-field (or Temperature Transfer Standard for f ≤ 800 MHz) and inside waveguide using analytical field distributions based on power measurements for f > 800 MHz. The same setups are used for assessment of the parameters applied for boundary compensation (alpha, depth) of which typical uncertainty values are given. These parameters are used in DASY4 software to improve probe accuracy close to the boundary. The sensitivity in TSL corresponds to *NORM_{x,y,z}* * *ConvF* whereby the uncertainty corresponds to that given for *ConvF*. A frequency dependent *ConvF* is used in DASY version 4.4 and higher which allows extending the validity from ± 50 MHz to ± 100 MHz.
- *Spherical isotropy (3D deviation from isotropy)*: in a field of low gradients realized using a flat phantom exposed by a patch antenna.
- *Sensor Offset*: The sensor offset corresponds to the offset of virtual measurement center from the probe tip (on probe axis). No tolerance required.
- *Connector Angle*: The angle is assessed using the information gained by determining the *NORM_x* (no uncertainty required).

Probe EX3DV4

SN:7406

Manufactured: November 24, 2015
Calibrated: April 19, 2016

Calibrated for DASY/EASY Systems
(Note: non-compatible with DASY2 system!)

DASY/EASY - Parameters of Probe: EX3DV4 - SN:7406

Basic Calibration Parameters

	Sensor X	Sensor Y	Sensor Z	Unc (k=2)
Norm ($\mu\text{V}/(\text{V}/\text{m})^2$) ^A	0.48	0.44	0.47	$\pm 10.1 \%$
DCP (mV) ^B	100.7	97.9	98.6	

Modulation Calibration Parameters

UID	Communication System Name		A dB	B dB/ μV	C	D dB	VR mV	Unc ^E (k=2)
0	CW	X	0.0	0.0	1.0	0.00	120.4	$\pm 3.3 \%$
		Y	0.0	0.0	1.0		148.3	
		Z	0.0	0.0	1.0		146.7	
10010- CAA	SAR Validation (Square, 100ms, 10ms)	X	0.81	54.6	7.4	10.00	50.3	$\pm 2.2 \%$
		Y	0.68	55.1	7.9		47.9	
		Z	1.34	61.0	11.0		46.8	
10012- CAB	IEEE 802.11b WiFi 2.4 GHz (DSSS, 1 Mbps)	X	2.83	68.0	18.3	1.87	127.8	$\pm 0.5 \%$
		Y	2.82	68.4	18.4		117.8	
		Z	3.00	69.2	19.0		115.9	
10100- CAB	LTE-FDD (SC-FDMA, 100% RB, 20 MHz, QPSK)	X	6.54	67.4	19.5	5.67	142.1	$\pm 1.2 \%$
		Y	6.19	66.7	19.3		127.6	
		Z	6.37	66.7	19.2		125.7	
10103- CAB	LTE-TDD (SC-FDMA, 100% RB, 20 MHz, QPSK)	X	7.58	67.9	21.8	9.29	114.4	$\pm 1.7 \%$
		Y	7.34	68.3	22.5		144.3	
		Z	7.53	67.7	21.8		139.5	
10108- CAC	LTE-FDD (SC-FDMA, 100% RB, 10 MHz, QPSK)	X	6.34	66.9	19.4	5.80	137.5	$\pm 1.2 \%$
		Y	5.90	65.9	19.0		123.8	
		Z	6.24	66.4	19.2		123.7	
10151- CAB	LTE-TDD (SC-FDMA, 50% RB, 20 MHz, QPSK)	X	7.17	67.2	21.5	9.28	109.5	$\pm 1.7 \%$
		Y	6.83	67.6	22.3		137.0	
		Z	7.23	67.4	21.7		135.1	
10154- CAC	LTE-FDD (SC-FDMA, 50% RB, 10 MHz, QPSK)	X	5.99	66.4	19.2	5.75	132.4	$\pm 0.9 \%$
		Y	5.61	65.8	19.1		119.4	
		Z	5.91	65.9	19.0		120.1	
10160- CAB	LTE-FDD (SC-FDMA, 50% RB, 15 MHz, QPSK)	X	6.47	67.0	19.5	5.82	137.0	$\pm 1.2 \%$
		Y	5.96	66.0	19.1		123.9	
		Z	6.33	66.3	19.1		124.2	
10169- CAB	LTE-FDD (SC-FDMA, 1 RB, 20 MHz, QPSK)	X	4.71	65.5	18.9	5.73	113.2	$\pm 1.2 \%$
		Y	4.60	66.2	19.6		144.2	
		Z	4.93	66.5	19.5		143.2	
10172- CAB	LTE-TDD (SC-FDMA, 1 RB, 20 MHz, QPSK)	X	5.68	68.2	22.4	9.21	117.6	$\pm 1.7 \%$
		Y	5.56	70.1	24.1		146.1	
		Z	5.87	69.4	23.2		143.7	
10175- CAC	LTE-FDD (SC-FDMA, 1 RB, 10 MHz, QPSK)	X	4.75	65.7	19.1	5.72	112.3	$\pm 0.9 \%$
		Y	4.58	66.1	19.5		143.2	
		Z	4.95	66.7	19.6		142.0	

10181-CAB	LTE-FDD (SC-FDMA, 1 RB, 15 MHz, QPSK)	X	4.71	65.5	18.9	5.72	110.2	±0.9 %
		Y	4.53	65.8	19.4		141.4	
		Z	4.90	66.5	19.5		138.1	
10237-CAB	LTE-TDD (SC-FDMA, 1 RB, 10 MHz, QPSK)	X	5.69	68.3	22.5	9.21	117.3	±1.7 %
		Y	5.47	69.5	23.8		145.1	
		Z	5.85	69.3	23.1		142.0	
10252-CAB	LTE-TDD (SC-FDMA, 50% RB, 10 MHz, QPSK)	X	7.04	68.1	22.2	9.24	141.2	±1.9 %
		Y	6.35	67.2	22.2		125.4	
		Z	6.82	67.1	21.7		127.5	
10267-CAB	LTE-TDD (SC-FDMA, 100% RB, 10 MHz, QPSK)	X	7.45	68.3	22.2	9.30	148.0	±1.9 %
		Y	6.84	67.5	22.3		132.0	
		Z	7.24	67.4	21.8		134.6	
10297-AAA	LTE-FDD (SC-FDMA, 50% RB, 20 MHz, QPSK)	X	6.35	66.9	19.4	5.81	135.3	±1.2 %
		Y	5.92	65.9	19.0		122.9	
		Z	6.26	66.4	19.2		122.1	
10311-AAA	LTE-FDD (SC-FDMA, 100% RB, 15 MHz, QPSK)	X	6.92	67.4	19.7	6.06	139.3	±1.2 %
		Y	6.52	66.6	19.5		127.9	
		Z	6.82	66.9	19.5		126.8	

The reported uncertainty of measurement is stated as the standard uncertainty of measurement multiplied by the coverage factor $k=2$, which for a normal distribution corresponds to a coverage probability of approximately 95%.

^A The uncertainties of Norm X,Y,Z do not affect the E^2 -field uncertainty inside TSL (see Pages 6 and 7).

^B Numerical linearization parameter: uncertainty not required.

^E Uncertainty is determined using the max. deviation from linear response applying rectangular distribution and is expressed for the square of the field value.

DASY/EASY - Parameters of Probe: EX3DV4 - SN:7406

Calibration Parameter Determined in Head Tissue Simulating Media

f (MHz) ^C	Relative Permittivity ^F	Conductivity (S/m) ^F	ConvF X	ConvF Y	ConvF Z	Alpha ^G	Depth ^G (mm)	Unc (k=2)
750	41.9	0.89	10.52	10.52	10.52	0.52	0.89	± 12.0 %
835	41.5	0.90	9.83	9.83	9.83	0.54	0.80	± 12.0 %
1750	40.1	1.37	8.85	8.85	8.85	0.49	0.85	± 12.0 %
1900	40.0	1.40	8.22	8.22	8.22	0.40	0.88	± 12.0 %
2300	39.5	1.67	7.67	7.67	7.67	0.36	0.89	± 12.0 %
2450	39.2	1.80	7.29	7.29	7.29	0.40	0.80	± 12.0 %
2600	39.0	1.96	7.08	7.08	7.08	0.37	0.95	± 12.0 %

^C Frequency validity above 300 MHz of ± 100 MHz only applies for DASY v4.4 and higher (see Page 2), else it is restricted to ± 50 MHz. The uncertainty is the RSS of the ConvF uncertainty at calibration frequency and the uncertainty for the indicated frequency band. Frequency validity below 300 MHz is ± 10, 25, 40, 50 and 70 MHz for ConvF assessments at 30, 64, 128, 150 and 220 MHz respectively. Above 5 GHz frequency validity can be extended to ± 110 MHz.

^F At frequencies below 3 GHz, the validity of tissue parameters (ϵ and σ) can be relaxed to ± 10% if liquid compensation formula is applied to measured SAR values. At frequencies above 3 GHz, the validity of tissue parameters (ϵ and σ) is restricted to ± 5%. The uncertainty is the RSS of the ConvF uncertainty for indicated target tissue parameters.

^G Alpha/Depth are determined during calibration. SPEAG warrants that the remaining deviation due to the boundary effect after compensation is always less than ± 1% for frequencies below 3 GHz and below ± 2% for frequencies between 3-6 GHz at any distance larger than half the probe tip diameter from the boundary.

DASY/EASY - Parameters of Probe: EX3DV4 - SN:7406

Calibration Parameter Determined in Body Tissue Simulating Media

f (MHz) ^C	Relative Permittivity ^F	Conductivity (S/m) ^F	ConvF X	ConvF Y	ConvF Z	Alpha ^G	Depth ^G (mm)	Unc (k=2)
750	55.5	0.96	9.54	9.54	9.54	0.46	0.80	± 12.0 %
835	55.2	0.97	9.35	9.35	9.35	0.45	0.84	± 12.0 %
1750	53.4	1.49	7.78	7.78	7.78	0.37	0.85	± 12.0 %
1900	53.3	1.52	7.49	7.49	7.49	0.33	0.91	± 12.0 %
2300	52.9	1.81	7.37	7.37	7.37	0.42	0.80	± 12.0 %
2450	52.7	1.95	7.24	7.24	7.24	0.37	0.88	± 12.0 %
2600	52.5	2.16	6.94	6.94	6.94	0.27	0.99	± 12.0 %

^C Frequency validity above 300 MHz of ± 100 MHz only applies for DASY v4.4 and higher (see Page 2), else it is restricted to ± 50 MHz. The uncertainty is the RSS of the ConvF uncertainty at calibration frequency and the uncertainty for the indicated frequency band. Frequency validity below 300 MHz is ± 10, 25, 40, 50 and 70 MHz for ConvF assessments at 30, 64, 128, 150 and 220 MHz respectively. Above 5 GHz frequency validity can be extended to ± 110 MHz.

^F At frequencies below 3 GHz, the validity of tissue parameters (ϵ and σ) can be relaxed to ± 10% if liquid compensation formula is applied to measured SAR values. At frequencies above 3 GHz, the validity of tissue parameters (ϵ and σ) is restricted to ± 5%. The uncertainty is the RSS of the ConvF uncertainty for indicated target tissue parameters.

^G Alpha/Depth are determined during calibration. SPEAG warrants that the remaining deviation due to the boundary effect after compensation is always less than ± 1% for frequencies below 3 GHz and below ± 2% for frequencies between 3-6 GHz at any distance larger than half the probe tip diameter from the boundary.

Frequency Response of E-Field (TEM-Cell:ifi110 EXX, Waveguide: R22)

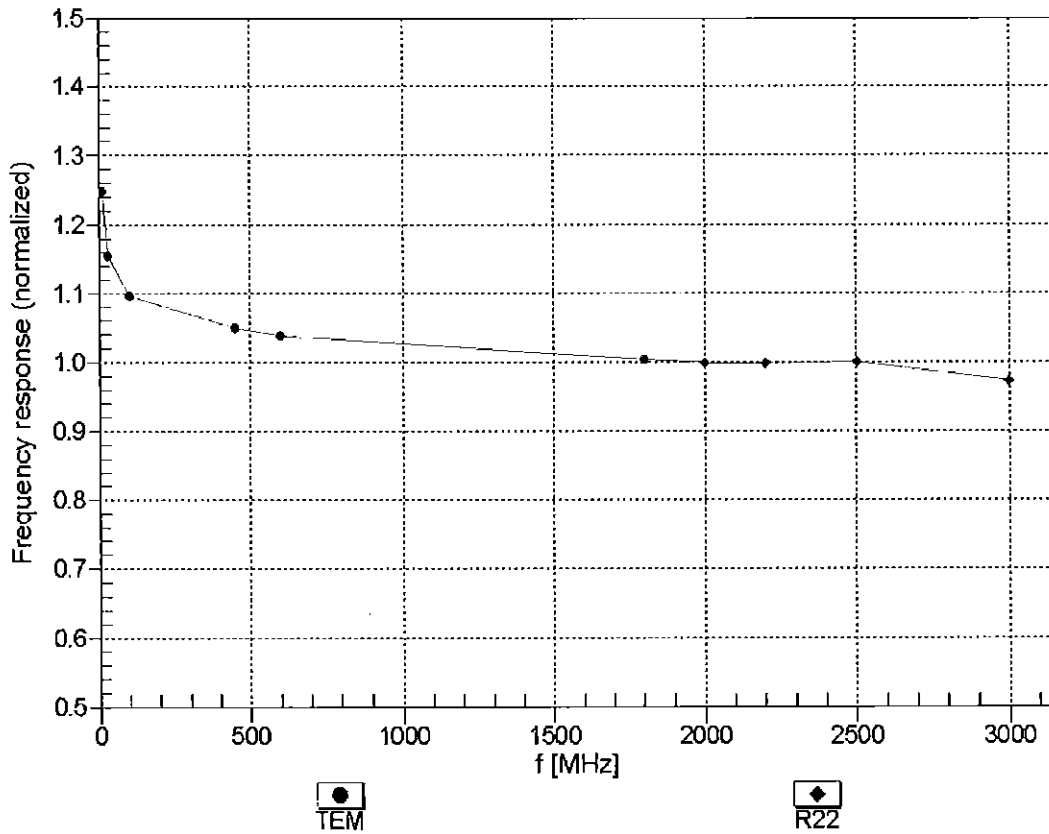

Uncertainty of Frequency Response of E-field: $\pm 6.3\%$ (k=2)

Receiving Pattern (ϕ), $\theta = 0^\circ$

f=600 MHz,TEM

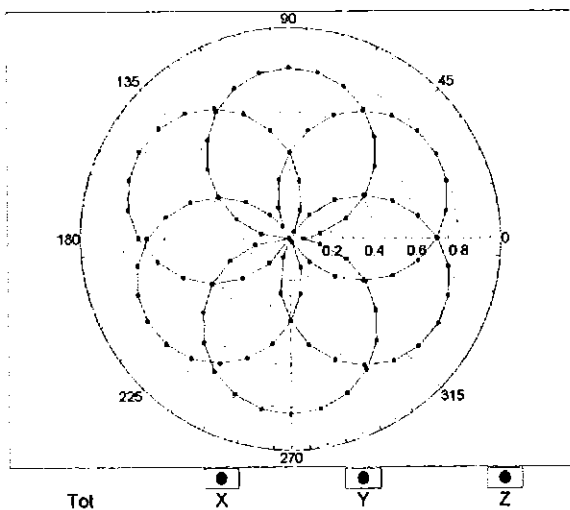

f=1800 MHz,R22

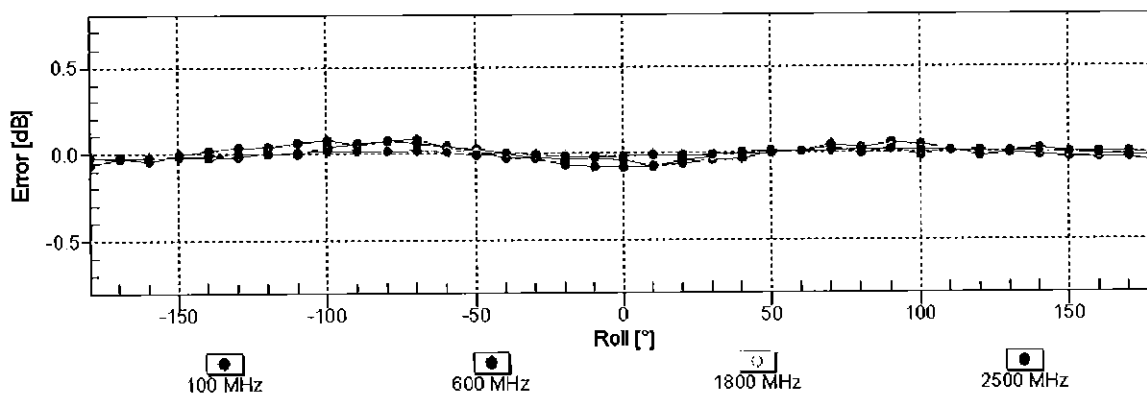
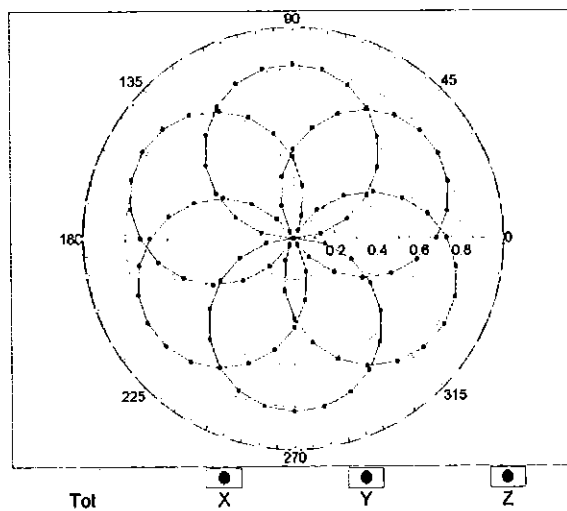

Uncertainty of Axial Isotropy Assessment: $\pm 0.5\%$ ($k=2$)

Dynamic Range f(SAR_{head}) (TEM cell , f_{eval}= 1900 MHz)

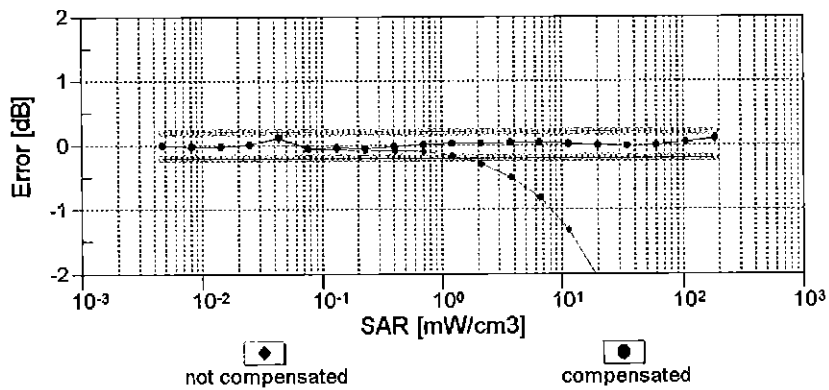
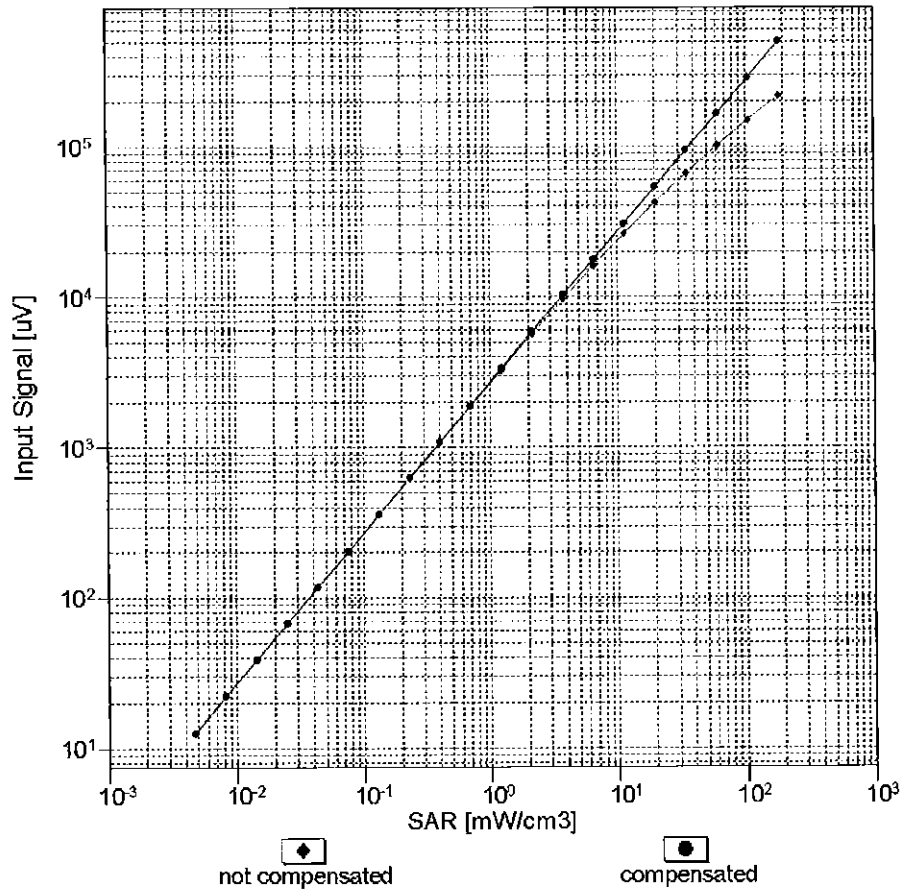

Uncertainty of Linearity Assessment: ± 0.6% (k=2)

Conversion Factor Assessment

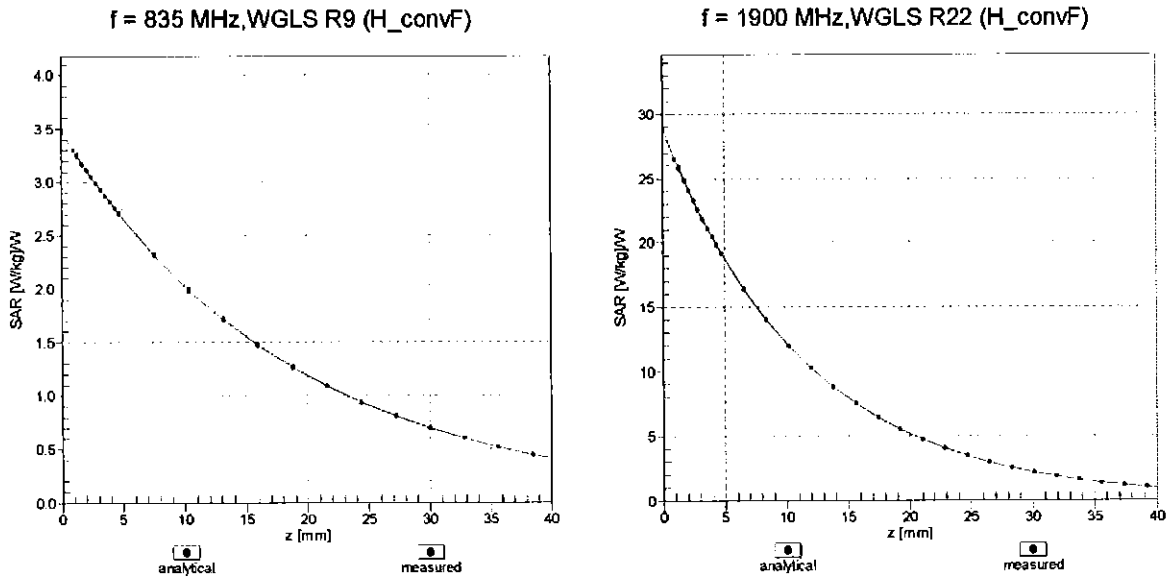

Deviation from Isotropy in Liquid Error (ϕ, ϑ), f = 900 MHz

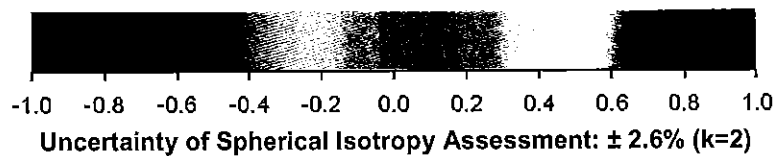
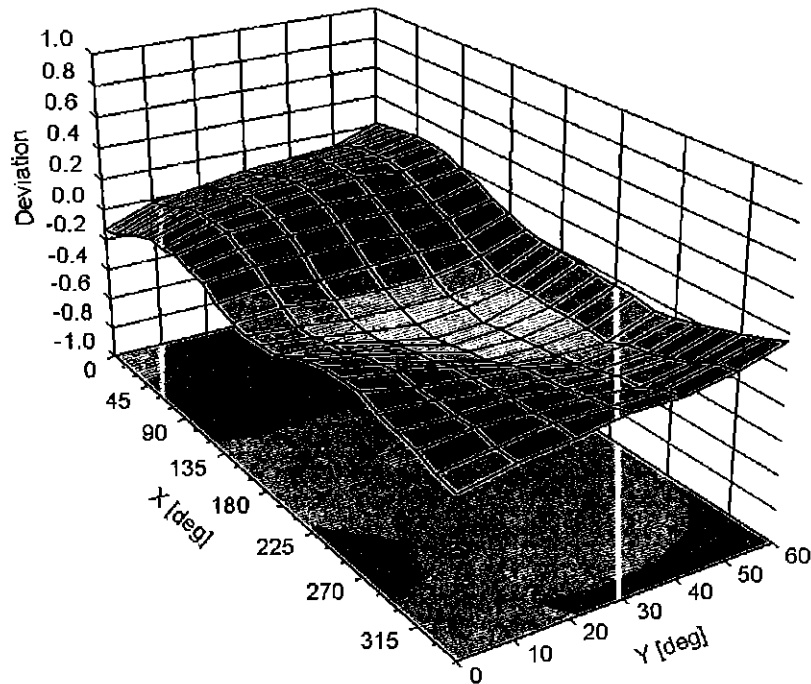

DASY/EASY - Parameters of Probe: EX3DV4 - SN:7406**Other Probe Parameters**

Sensor Arrangement	Triangular
Connector Angle (°)	0.4
Mechanical Surface Detection Mode	enabled
Optical Surface Detection Mode	disabled
Probe Overall Length	337 mm
Probe Body Diameter	10 mm
Tip Length	9 mm
Tip Diameter	2.5 mm
Probe Tip to Sensor X Calibration Point	1 mm
Probe Tip to Sensor Y Calibration Point	1 mm
Probe Tip to Sensor Z Calibration Point	1 mm
Recommended Measurement Distance from Surface	1.4 mm



Accredited by the Swiss Accreditation Service (SAS)
 The Swiss Accreditation Service is one of the signatories to the EA
 Multilateral Agreement for the recognition of calibration certificates

Accreditation No.: **SCS 0108**

Client **PC Test**

Certificate No: **ES3-3319_Mar16**

CALIBRATION CERTIFICATE

Object: **ES3DV3 - SN:3319**

Calibration procedure(s): **QA CAL-01.v9, QA CAL-23.v5, QA CAL-25.v6
 Calibration procedure for dosimetric E-field probes**

Calibration date: **March 18, 2016**

*BN
 03/18/2016*

This calibration certificate documents the traceability to national standards, which realize the physical units of measurements (SI).
 The measurements and the uncertainties with confidence probability are given on the following pages and are part of the certificate.

All calibrations have been conducted in the closed laboratory facility: environment temperature (22 ± 3)°C and humidity < 70%.

Calibration Equipment used (M&TE critical for calibration)

Primary Standards	ID	Cal Date (Certificate No.)	Scheduled Calibration
Power meter E4419B	GB41293874	01-Apr-15 (No. 217-02128)	Mar-16
Power sensor E4412A	MY41498087	01-Apr-15 (No. 217-02128)	Mar-16
Reference 3 dB Attenuator	SN: S5054 (3c)	01-Apr-15 (No. 217-02129)	Mar-16
Reference 20 dB Attenuator	SN: S5277 (20x)	01-Apr-15 (No. 217-02132)	Mar-16
Reference 30 dB Attenuator	SN: S5129 (30b)	01-Apr-15 (No. 217-02133)	Mar-16
Reference Probe ES3DV2	SN: 3013	31-Dec-15 (No. ES3-3013_Dec15)	Dec-16
DAE4	SN: 660	23-Dec-15 (No. DAE4-660_Dec15)	Dec-16
Secondary Standards	ID	Check Date (in house)	Scheduled Check
RF generator HP 8648C	US3642U01700	4-Aug-99 (in house check Apr-13)	In house check: Apr-16
Network Analyzer HP 8753E	US37390585	18-Oct-01 (in house check Oct-15)	In house check: Oct-16

	Name	Function	Signature
Calibrated by:	Leif Klysner	Laboratory Technician	<i>Leif Klysner</i>
Approved by:	Katja Pokovic	Technical Manager	<i>Katja Pokovic</i>

Issued: March 21, 2016

This calibration certificate shall not be reproduced except in full without written approval of the laboratory.



Accredited by the Swiss Accreditation Service (SAS)

Accreditation No.: **SCS 0108**

The Swiss Accreditation Service is one of the signatories to the EA Multilateral Agreement for the recognition of calibration certificates

Glossary:

TSL	tissue simulating liquid
NORM _{x,y,z}	sensitivity in free space
ConvF	sensitivity in TSL / NORM _{x,y,z}
DCP	diode compression point
CF	crest factor (1/duty_cycle) of the RF signal
A, B, C, D	modulation dependent linearization parameters
Polarization φ	φ rotation around probe axis
Polarization ϑ	ϑ rotation around an axis that is in the plane normal to probe axis (at measurement center), i.e., $\vartheta = 0$ is normal to probe axis
Connector Angle	information used in DASY system to align probe sensor X to the robot coordinate system

Calibration is Performed According to the Following Standards:

- a) IEEE Std 1528-2013, "IEEE Recommended Practice for Determining the Peak Spatial-Averaged Specific Absorption Rate (SAR) in the Human Head from Wireless Communications Devices: Measurement Techniques", June 2013
- b) IEC 62209-1, "Procedure to measure the Specific Absorption Rate (SAR) for hand-held devices used in close proximity to the ear (frequency range of 300 MHz to 3 GHz)", February 2005
- c) IEC 62209-2, "Procedure to determine the Specific Absorption Rate (SAR) for wireless communication devices used in close proximity to the human body (frequency range of 30 MHz to 6 GHz)", March 2010
- d) KDB 865664, "SAR Measurement Requirements for 100 MHz to 6 GHz"

Methods Applied and Interpretation of Parameters:

- *NORM_{x,y,z}*: Assessed for E-field polarization $\vartheta = 0$ ($f \leq 900$ MHz in TEM-cell; $f > 1800$ MHz: R22 waveguide). *NORM_{x,y,z}* are only intermediate values, i.e., the uncertainties of *NORM_{x,y,z}* does not affect the E^2 -field uncertainty inside TSL (see below *ConvF*).
- *NORM(f)_{x,y,z} = NORM_{x,y,z} * frequency_response* (see Frequency Response Chart). This linearization is implemented in DASY4 software versions later than 4.2. The uncertainty of the frequency response is included in the stated uncertainty of *ConvF*.
- *DCP_{x,y,z}*: DCP are numerical linearization parameters assessed based on the data of power sweep with CW signal (no uncertainty required). DCP does not depend on frequency nor media.
- *PAR*: PAR is the Peak to Average Ratio that is not calibrated but determined based on the signal characteristics
- *A_{x,y,z}; B_{x,y,z}; C_{x,y,z}; D_{x,y,z}; VR_{x,y,z}*: *A, B, C, D* are numerical linearization parameters assessed based on the data of power sweep for specific modulation signal. The parameters do not depend on frequency nor media. *VR* is the maximum calibration range expressed in RMS voltage across the diode.
- *ConvF and Boundary Effect Parameters*: Assessed in flat phantom using E-field (or Temperature Transfer Standard for $f \leq 800$ MHz) and inside waveguide using analytical field distributions based on power measurements for $f > 800$ MHz. The same setups are used for assessment of the parameters applied for boundary compensation (alpha, depth) of which typical uncertainty values are given. These parameters are used in DASY4 software to improve probe accuracy close to the boundary. The sensitivity in TSL corresponds to *NORM_{x,y,z} * ConvF* whereby the uncertainty corresponds to that given for *ConvF*. A frequency dependent *ConvF* is used in DASY version 4.4 and higher which allows extending the validity from ± 50 MHz to ± 100 MHz.
- *Spherical isotropy (3D deviation from isotropy)*: in a field of low gradients realized using a flat phantom exposed by a patch antenna.
- *Sensor Offset*: The sensor offset corresponds to the offset of virtual measurement center from the probe tip (on probe axis). No tolerance required.
- *Connector Angle*: The angle is assessed using the information gained by determining the *NORM_x* (no uncertainty required).

Probe ES3DV3

SN:3319

Manufactured: January 10, 2012
Calibrated: March 18, 2016

Calibrated for DASY/EASY Systems
(Note: non-compatible with DASY2 system!)

DASY/EASY - Parameters of Probe: ES3DV3 - SN:3319

Basic Calibration Parameters

	Sensor X	Sensor Y	Sensor Z	Unc (k=2)
Norm ($\mu\text{V}/(\text{V}/\text{m})^2$) ^A	1.12	1.08	1.16	$\pm 10.1 \%$
DCP (mV) ^B	104.1	104.5	103.7	

Modulation Calibration Parameters

UID	Communication System Name		A dB	B dB $\sqrt{\mu\text{V}}$	C	D dB	VR mV	Unc ^E (k=2)
0	CW	X	0.0	0.0	1.0	0.00	203.1	$\pm 3.5 \%$
		Y	0.0	0.0	1.0		203.8	
		Z	0.0	0.0	1.0		200.4	
10010- CAA	SAR Validation (Square, 100ms, 10ms)	X	2.29	60.1	11.2	10.00	42.0	$\pm 1.2 \%$
		Y	1.95	58.7	10.4		42.0	
		Z	3.15	62.5	12.1		42.9	
10012- CAB	IEEE 802.11b WiFi 2.4 GHz (DSSS, 1 Mbps)	X	3.45	71.5	19.9	1.87	122.0	$\pm 0.5 \%$
		Y	2.88	68.4	18.6		122.8	
		Z	3.35	70.8	19.5		120.5	
10100- CAB	LTE-FDD (SC-FDMA, 100% RB, 20 MHz, QPSK)	X	6.39	67.3	19.5	5.67	132.3	$\pm 1.2 \%$
		Y	6.54	68.2	20.1		134.5	
		Z	6.40	67.4	19.6		130.2	
10103- CAB	LTE-TDD (SC-FDMA, 100% RB, 20 MHz, QPSK)	X	10.41	75.3	25.6	9.29	124.2	$\pm 2.2 \%$
		Y	10.45	76.3	26.6		122.6	
		Z	10.82	75.9	25.8		124.8	
10108- CAC	LTE-FDD (SC-FDMA, 100% RB, 10 MHz, QPSK)	X	6.30	67.1	19.5	5.80	130.7	$\pm 1.2 \%$
		Y	6.35	67.5	19.9		131.5	
		Z	6.33	67.1	19.6		128.5	
10151- CAB	LTE-TDD (SC-FDMA, 50% RB, 20 MHz, QPSK)	X	9.70	74.1	25.2	9.28	118.8	$\pm 2.2 \%$
		Y	9.65	74.9	26.0		117.1	
		Z	10.15	75.0	25.5		119.2	
10154- CAC	LTE-FDD (SC-FDMA, 50% RB, 10 MHz, QPSK)	X	6.00	66.6	19.3	5.75	127.4	$\pm 1.2 \%$
		Y	6.01	66.9	19.6		128.9	
		Z	6.02	66.6	19.3		125.6	
10160- CAB	LTE-FDD (SC-FDMA, 50% RB, 15 MHz, QPSK)	X	6.45	67.2	19.6	5.82	132.2	$\pm 1.2 \%$
		Y	6.47	67.5	19.9		133.5	
		Z	6.45	67.1	19.5		130.0	
10169- CAB	LTE-FDD (SC-FDMA, 1 RB, 20 MHz, QPSK)	X	4.76	65.7	19.0	5.73	110.8	$\pm 0.9 \%$
		Y	4.80	66.3	19.5		112.0	
		Z	4.84	65.9	19.1		109.2	
10172- CAB	LTE-TDD (SC-FDMA, 1 RB, 20 MHz, QPSK)	X	8.98	78.7	27.7	9.21	132.0	$\pm 2.5 \%$
		Y	9.71	82.4	30.0		132.2	
		Z	9.79	80.4	28.4		133.4	
10175- CAC	LTE-FDD (SC-FDMA, 1 RB, 10 MHz, QPSK)	X	4.76	65.6	19.0	5.72	109.8	$\pm 0.9 \%$
		Y	4.76	66.1	19.4		111.4	
		Z	4.83	65.8	19.1		108.9	

10181-CAB	LTE-FDD (SC-FDMA, 1 RB, 15 MHz, QPSK)	X	4.77	65.7	19.1	5.72	109.2	±0.9 %
		Y	4.78	66.2	19.4		111.9	
		Z	5.24	67.7	20.2		149.0	
10237-CAB	LTE-TDD (SC-FDMA, 1 RB, 10 MHz, QPSK)	X	8.93	78.5	27.6	9.21	131.4	±2.5 %
		Y	9.48	81.7	29.7		131.7	
		Z	9.69	80.3	28.3		131.6	
10252-CAB	LTE-TDD (SC-FDMA, 50% RB, 10 MHz, QPSK)	X	8.94	73.0	24.7	9.24	111.2	±2.2 %
		Y	9.05	74.3	25.9		111.8	
		Z	9.29	73.6	24.9		111.3	
10267-CAB	LTE-TDD (SC-FDMA, 100% RB, 10 MHz, QPSK)	X	9.62	73.9	25.1	9.30	117.4	±2.2 %
		Y	9.73	75.1	26.1		118.2	
		Z	10.08	74.8	25.5		118.2	
10297-AAA	LTE-FDD (SC-FDMA, 50% RB, 20 MHz, QPSK)	X	6.31	67.1	19.6	5.81	128.6	±1.2 %
		Y	6.39	67.6	20.0		132.2	
		Z	6.33	67.1	19.6		127.2	
10311-AAA	LTE-FDD (SC-FDMA, 100% RB, 15 MHz, QPSK)	X	6.87	67.6	19.9	6.06	132.8	±1.4 %
		Y	6.96	68.2	20.3		137.0	
		Z	6.88	67.6	19.9		131.3	

The reported uncertainty of measurement is stated as the standard uncertainty of measurement multiplied by the coverage factor $k=2$, which for a normal distribution corresponds to a coverage probability of approximately 95%.

^A The uncertainties of Norm X,Y,Z do not affect the E^2 -field uncertainty inside TSL (see Pages 6 and 7).

^B Numerical linearization parameter: uncertainty not required.

^E Uncertainty is determined using the max. deviation from linear response applying rectangular distribution and is expressed for the square of the field value.

DASY/EASY - Parameters of Probe: ES3DV3 - SN:3319

Calibration Parameter Determined in Head Tissue Simulating Media

f (MHz) ^C	Relative Permittivity ^F	Conductivity (S/m) ^F	ConvF X	ConvF Y	ConvF Z	Alpha ^G	Depth ^G (mm)	Unc (k=2)
750	41.9	0.89	6.44	6.44	6.44	0.49	1.80	± 12.0 %
835	41.5	0.90	6.16	6.16	6.16	0.46	1.80	± 12.0 %
1750	40.1	1.37	5.20	5.20	5.20	0.51	1.45	± 12.0 %
1900	40.0	1.40	5.03	5.03	5.03	0.58	1.40	± 12.0 %
2300	39.5	1.67	4.69	4.69	4.69	0.80	1.21	± 12.0 %
2450	39.2	1.80	4.47	4.47	4.47	0.75	1.32	± 12.0 %
2600	39.0	1.96	4.33	4.33	4.33	0.80	1.31	± 12.0 %

^C Frequency validity above 300 MHz of ± 100 MHz only applies for DASY v4.4 and higher (see Page 2), else it is restricted to ± 50 MHz. The uncertainty is the RSS of the ConvF uncertainty at calibration frequency and the uncertainty for the indicated frequency band. Frequency validity below 300 MHz is ± 10, 25, 40, 50 and 70 MHz for ConvF assessments at 30, 64, 128, 150 and 220 MHz respectively. Above 5 GHz frequency validity can be extended to ± 110 MHz.

^F At frequencies below 3 GHz, the validity of tissue parameters (ϵ and σ) can be relaxed to ± 10% if liquid compensation formula is applied to measured SAR values. At frequencies above 3 GHz, the validity of tissue parameters (ϵ and σ) is restricted to ± 5%. The uncertainty is the RSS of the ConvF uncertainty for indicated target tissue parameters.

^G Alpha/Depth are determined during calibration. SPEAG warrants that the remaining deviation due to the boundary effect after compensation is always less than ± 1% for frequencies below 3 GHz and below ± 2% for frequencies between 3-6 GHz at any distance larger than half the probe tip diameter from the boundary.

DASY/EASY - Parameters of Probe: ES3DV3 - SN:3319

Calibration Parameter Determined in Body Tissue Simulating Media

f (MHz) ^C	Relative Permittivity ^F	Conductivity (S/m) ^F	ConvF X	ConvF Y	ConvF Z	Alpha ^G	Depth ^G (mm)	Unc (k=2)
750	55.5	0.96	6.06	6.06	6.06	0.47	1.45	± 12.0 %
835	55.2	0.97	6.04	6.04	6.04	0.63	1.27	± 12.0 %
1750	53.4	1.49	4.91	4.91	4.91	0.46	1.66	± 12.0 %
1900	53.3	1.52	4.70	4.70	4.70	0.80	1.24	± 12.0 %
2300	52.9	1.81	4.36	4.36	4.36	0.74	1.33	± 12.0 %
2450	52.7	1.95	4.20	4.20	4.20	0.80	1.25	± 12.0 %
2600	52.5	2.16	3.99	3.99	3.99	0.80	1.20	± 12.0 %

^C Frequency validity above 300 MHz of ± 100 MHz only applies for DASY v4.4 and higher (see Page 2), else it is restricted to ± 50 MHz. The uncertainty is the RSS of the ConvF uncertainty at calibration frequency and the uncertainty for the indicated frequency band. Frequency validity below 300 MHz is ± 10, 25, 40, 50 and 70 MHz for ConvF assessments at 30, 64, 128, 150 and 220 MHz respectively. Above 5 GHz frequency validity can be extended to ± 110 MHz.

^F At frequencies below 3 GHz, the validity of tissue parameters (ϵ and σ) can be relaxed to ± 10% if liquid compensation formula is applied to measured SAR values. At frequencies above 3 GHz, the validity of tissue parameters (ϵ and σ) is restricted to ± 5%. The uncertainty is the RSS of the ConvF uncertainty for indicated target tissue parameters.

^G Alpha/Depth are determined during calibration. SPEAG warrants that the remaining deviation due to the boundary effect after compensation is always less than ± 1% for frequencies below 3 GHz and below ± 2% for frequencies between 3-6 GHz at any distance larger than half the probe tip diameter from the boundary.

Frequency Response of E-Field (TEM-Cell:ifi110 EXX, Waveguide: R22)

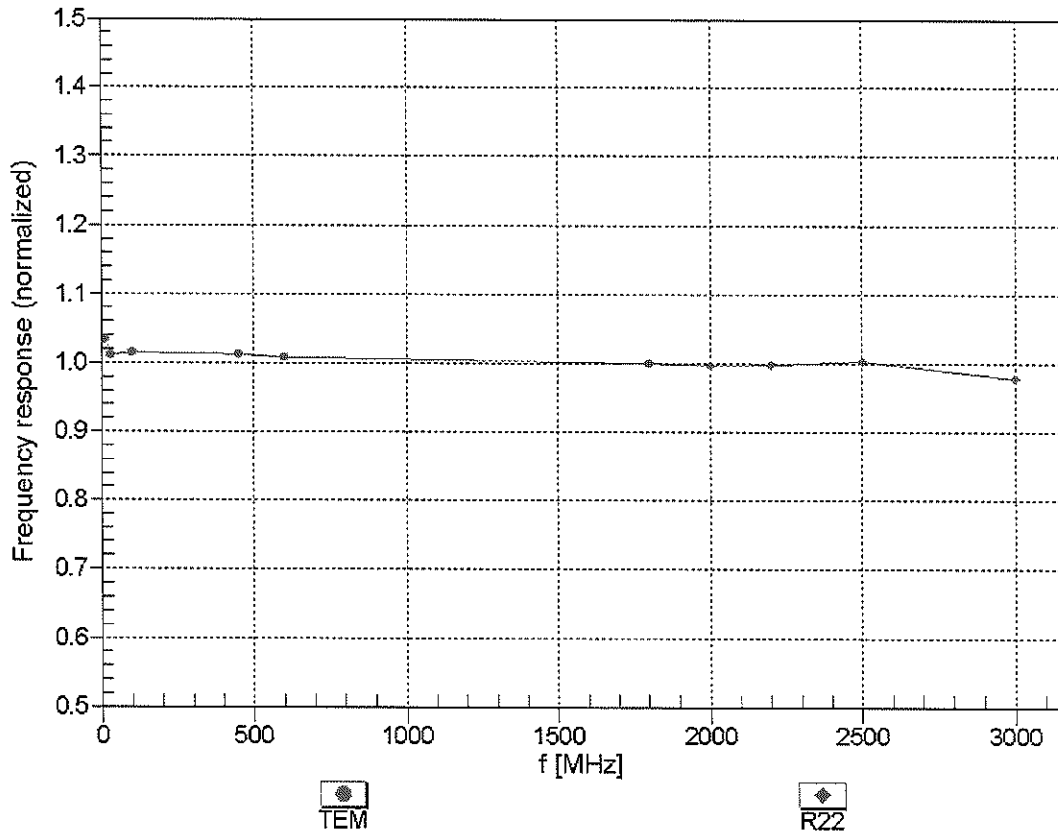

Uncertainty of Frequency Response of E-field: $\pm 6.3\%$ (k=2)

Receiving Pattern (ϕ), $\theta = 0^\circ$

f=600 MHz,TEM

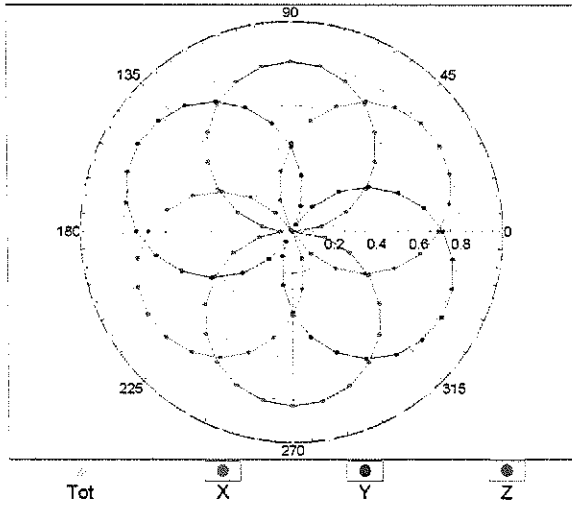

f=1800 MHz,R22

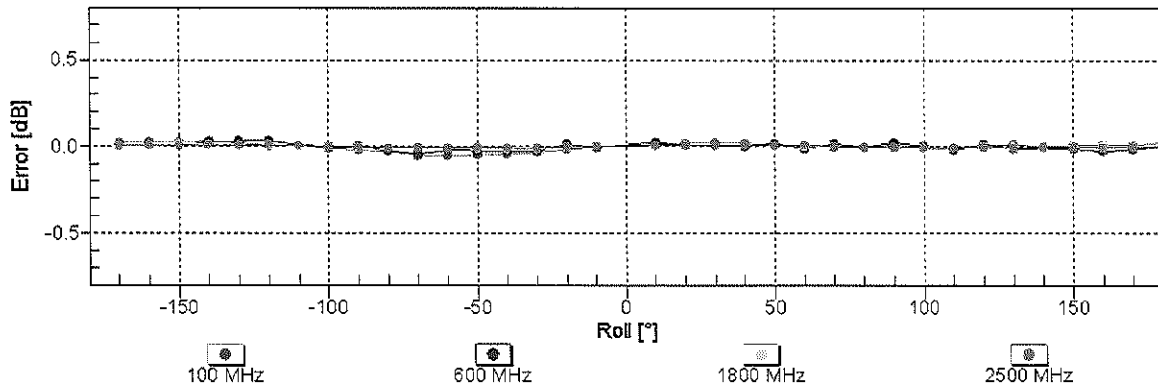
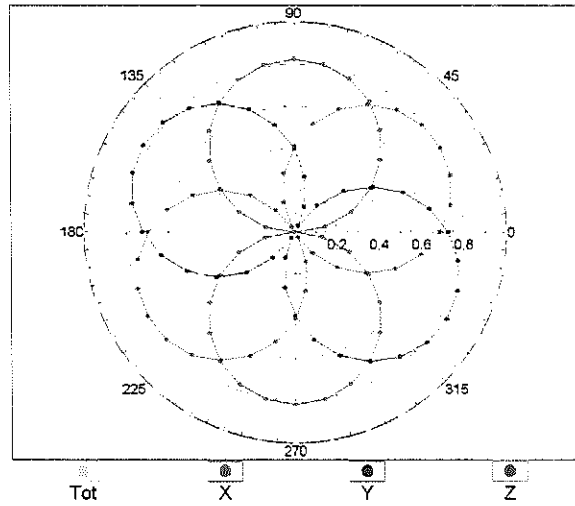

Uncertainty of Axial Isotropy Assessment: $\pm 0.5\%$ (k=2)

Dynamic Range f(SAR_{head}) (TEM cell , f_{eval}= 1900 MHz)

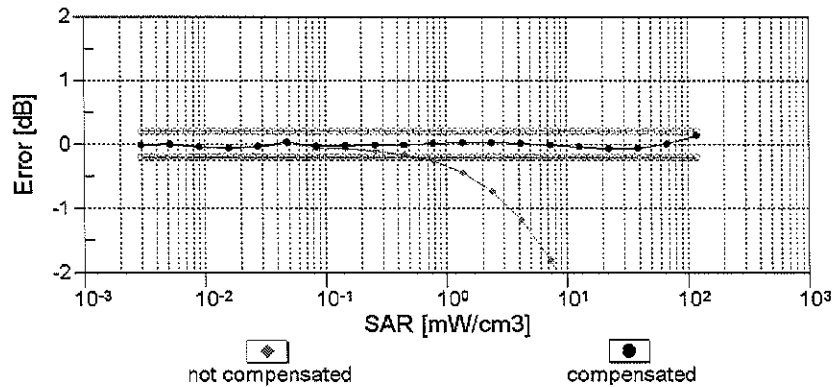
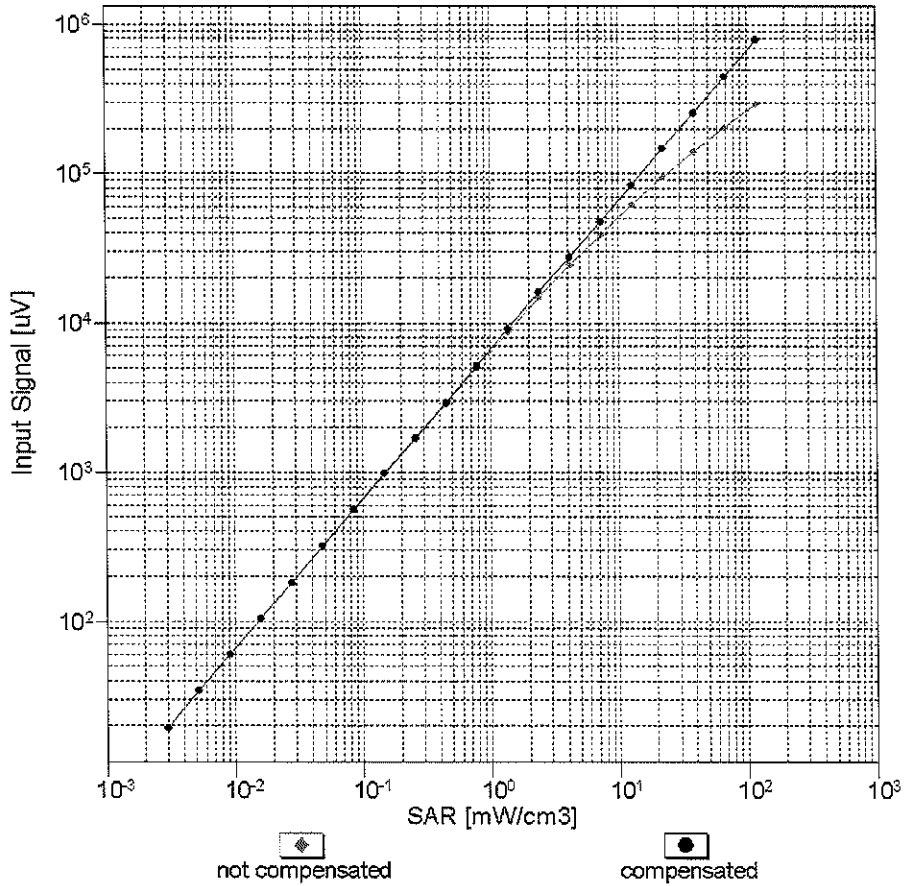

Uncertainty of Linearity Assessment: ± 0.6% (k=2)

Conversion Factor Assessment

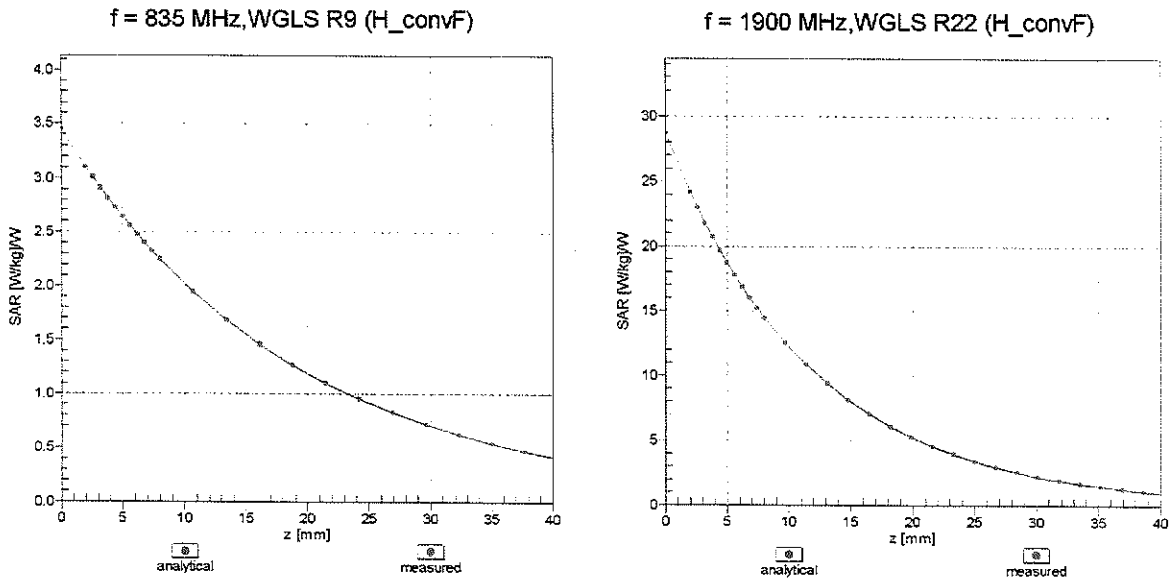

Deviation from Isotropy in Liquid Error (ϕ, ϑ), f = 900 MHz

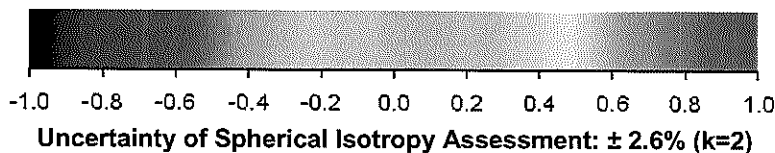
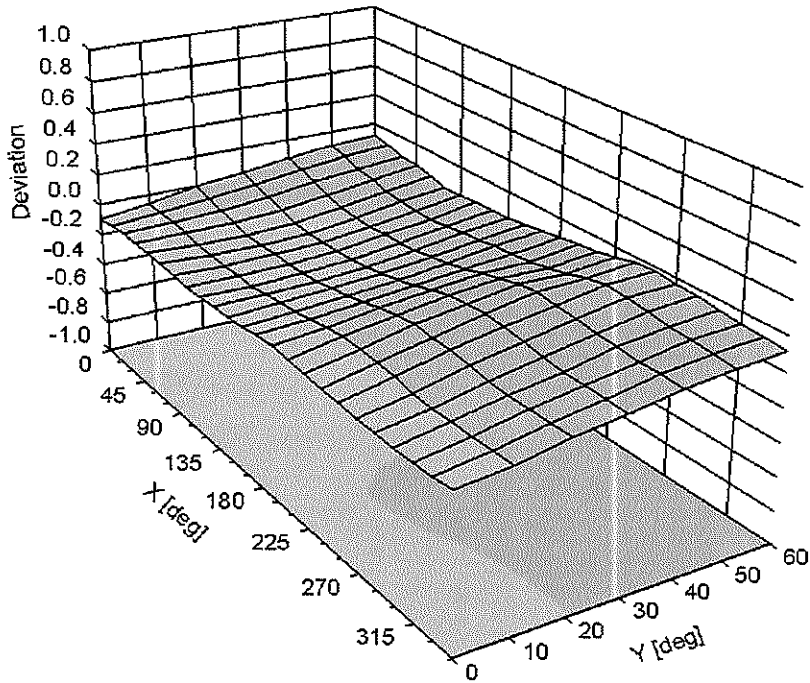

DASY/EASY - Parameters of Probe: ES3DV3 - SN:3319

Other Probe Parameters

Sensor Arrangement	Triangular
Connector Angle (°)	60
Mechanical Surface Detection Mode	enabled
Optical Surface Detection Mode	disabled
Probe Overall Length	337 mm
Probe Body Diameter	10 mm
Tip Length	10 mm
Tip Diameter	4 mm
Probe Tip to Sensor X Calibration Point	2 mm
Probe Tip to Sensor Y Calibration Point	2 mm
Probe Tip to Sensor Z Calibration Point	2 mm
Recommended Measurement Distance from Surface	3 mm



Accredited by the Swiss Accreditation Service (SAS)
The Swiss Accreditation Service is one of the signatories to the EA
Multilateral Agreement for the recognition of calibration certificates

Accreditation No.: **SCS 0108**

Client **PC Test**

Certificate No: **EX3-7409_May16**

CALIBRATION CERTIFICATE

Object **EX3DV4 - SN:7409**

Calibration procedure(s) **QA CAL-01.v9, QA CAL-23.v5, QA CAL-25.v6**
Calibration procedure for dosimetric E-field probes

Calibration date: **May 17, 2016**

This calibration certificate documents the traceability to national standards, which realize the physical units of measurements (SI).
The measurements and the uncertainties with confidence probability are given on the following pages and are part of the certificate.

All calibrations have been conducted in the closed laboratory facility: environment temperature (22 ± 3)°C and humidity < 70%.

Calibration Equipment used (M&TE critical for calibration)

*BN ✓
05/23/16*

Primary Standards	ID	Cal Date (Certificate No.)	Scheduled Calibration
Power meter NRP	SN: 104778	06-Apr-16 (No. 217-02288/02289)	Apr-17
Power sensor NRP-Z91	SN: 103244	06-Apr-16 (No. 217-02288)	Apr-17
Power sensor NRP-Z91	SN: 103245	06-Apr-16 (No. 217-02289)	Apr-17
Reference 20 dB Attenuator	SN: S5277 (20x)	05-Apr-16 (No. 217-02293)	Apr-17
Reference Probe ES3DV2	SN: 3013	31-Dec-15 (No. ES3-3013_Dec15)	Dec-16
DAE4	SN: 660	23-Dec-15 (No. DAE4-660_Dec15)	Dec-16
Secondary Standards	ID	Check Date (in house)	Scheduled Check
Power meter E4419B	SN: GB41293874	06-Apr-16 (No. 217-02285/02284)	In house check: Jun-16
Power sensor E4412A	SN: MY41498087	06-Apr-16 (No. 217-02285)	In house check: Jun-16
Power sensor E4412A	SN: 000110210	06-Apr-16 (No. 217-02284)	In house check: Jun-16
RF generator HP 8648C	SN: US3642U01700	04-Aug-99 (in house check Apr-13)	In house check: Jun-16
Network Analyzer HP 8753E	SN: US37390585	18-Oct-01 (in house check Oct-15)	In house check: Oct-16

Calibrated by:	Name Michael Weber	Function Laboratory Technician	Signature <i>M. Weber</i>
Approved by:	Name Katja Pokovic	Function Technical Manager	Signature <i>Katja Pokovic</i>
			Issued: May 18, 2016

This calibration certificate shall not be reproduced except in full without written approval of the laboratory.



Accredited by the Swiss Accreditation Service (SAS)

Accreditation No.: **SCS 0108**

The Swiss Accreditation Service is one of the signatories to the EA
Multilateral Agreement for the recognition of calibration certificates

Glossary:

TSL	tissue simulating liquid
NORM _{x,y,z}	sensitivity in free space
ConvF	sensitivity in TSL / NORM _{x,y,z}
DCP	diode compression point
CF	crest factor (1/duty_cycle) of the RF signal
A, B, C, D	modulation dependent linearization parameters
Polarization φ	φ rotation around probe axis
Polarization ϑ	ϑ rotation around an axis that is in the plane normal to probe axis (at measurement center), i.e., $\vartheta = 0$ is normal to probe axis
Connector Angle	information used in DASY system to align probe sensor X to the robot coordinate system

Calibration is Performed According to the Following Standards:

- a) IEEE Std 1528-2013, "IEEE Recommended Practice for Determining the Peak Spatial-Averaged Specific Absorption Rate (SAR) in the Human Head from Wireless Communications Devices: Measurement Techniques", June 2013
- b) IEC 62209-1, "Procedure to measure the Specific Absorption Rate (SAR) for hand-held devices used in close proximity to the ear (frequency range of 300 MHz to 3 GHz)", February 2005
- c) IEC 62209-2, "Procedure to determine the Specific Absorption Rate (SAR) for wireless communication devices used in close proximity to the human body (frequency range of 30 MHz to 6 GHz)", March 2010
- d) KDB 865664, "SAR Measurement Requirements for 100 MHz to 6 GHz"

Methods Applied and Interpretation of Parameters:

- *NORM_{x,y,z}*: Assessed for E-field polarization $\vartheta = 0$ ($f \leq 900$ MHz in TEM-cell; $f > 1800$ MHz: R22 waveguide). *NORM_{x,y,z}* are only intermediate values, i.e., the uncertainties of *NORM_{x,y,z}* does not affect the E^2 -field uncertainty inside TSL (see below *ConvF*).
- *NORM(f)_{x,y,z}* = *NORM_{x,y,z}* * *frequency_response* (see Frequency Response Chart). This linearization is implemented in DASY4 software versions later than 4.2. The uncertainty of the frequency response is included in the stated uncertainty of *ConvF*.
- *DCP_{x,y,z}*: DCP are numerical linearization parameters assessed based on the data of power sweep with CW signal (no uncertainty required). DCP does not depend on frequency nor media.
- *PAR*: PAR is the Peak to Average Ratio that is not calibrated but determined based on the signal characteristics
- *A_{x,y,z}; B_{x,y,z}; C_{x,y,z}; D_{x,y,z}; VR_{x,y,z}; A, B, C, D* are numerical linearization parameters assessed based on the data of power sweep for specific modulation signal. The parameters do not depend on frequency nor media. *VR* is the maximum calibration range expressed in RMS voltage across the diode.
- *ConvF and Boundary Effect Parameters*: Assessed in flat phantom using E-field (or Temperature Transfer Standard for $f \leq 800$ MHz) and inside waveguide using analytical field distributions based on power measurements for $f > 800$ MHz. The same setups are used for assessment of the parameters applied for boundary compensation (alpha, depth) of which typical uncertainty values are given. These parameters are used in DASY4 software to improve probe accuracy close to the boundary. The sensitivity in TSL corresponds to *NORM_{x,y,z}* * *ConvF* whereby the uncertainty corresponds to that given for *ConvF*. A frequency dependent *ConvF* is used in DASY version 4.4 and higher which allows extending the validity from ± 50 MHz to ± 100 MHz.
- *Spherical isotropy (3D deviation from isotropy)*: in a field of low gradients realized using a flat phantom exposed by a patch antenna.
- *Sensor Offset*: The sensor offset corresponds to the offset of virtual measurement center from the probe tip (on probe axis). No tolerance required.
- *Connector Angle*: The angle is assessed using the information gained by determining the *NORM_x* (no uncertainty required).

Probe EX3DV4

SN:7409

Manufactured: November 24, 2015
Calibrated: May 17, 2016

Calibrated for DASY/EASY Systems
(Note: non-compatible with DASY2 system!)

DASY/EASY - Parameters of Probe: EX3DV4 - SN:7409

Basic Calibration Parameters

	Sensor X	Sensor Y	Sensor Z	Unc (k=2)
Norm ($\mu\text{V}/(\text{V}/\text{m})^2$) ^A	0.39	0.34	0.39	$\pm 10.1 \%$
DCP (mV) ^B	106.3	102.2	99.4	

Modulation Calibration Parameters

UID	Communication System Name		A dB	B dB $\sqrt{\mu\text{V}}$	C	D dB	VR mV	Unc ^F (k=2)
0	CW	X	0.0	0.0	1.0	0.00	141.2	$\pm 3.3 \%$
		Y	0.0	0.0	1.0		127.3	
		Z	0.0	0.0	1.0		131.8	
10010- CAA	SAR Validation (Square, 100ms, 10ms)	X	0.39	53.8	5.5	10.00	42.5	$\pm 1.2 \%$
		Y	0.55	54.7	5.9		41.8	
		Z	0.85	58.7	9.1		41.6	
10012- CAB	IEEE 802.11b WiFi 2.4 GHz (DSSS, 1 Mbps)	X	3.55	75.3	22.2	1.87	149.7	$\pm 0.7 \%$
		Y	3.32	72.6	21.0		139.7	
		Z	2.84	68.8	19.0		144.7	
10100- CAB	LTE-FDD (SC-FDMA, 100% RB, 20 MHz, QPSK)	X	5.98	66.6	19.3	5.67	113.6	$\pm 0.9 \%$
		Y	6.17	66.7	19.4		107.1	
		Z	6.13	66.1	18.8		110.9	
10103- CAB	LTE-TDD (SC-FDMA, 100% RB, 20 MHz, QPSK)	X	6.59	66.2	21.1	9.29	123.5	$\pm 1.4 \%$
		Y	7.27	67.9	22.1		121.1	
		Z	7.01	66.4	21.1		119.9	
10108- CAC	LTE-FDD (SC-FDMA, 100% RB, 10 MHz, QPSK)	X	5.72	66.1	19.2	5.80	111.4	$\pm 1.2 \%$
		Y	6.34	67.6	20.0		149.2	
		Z	6.02	65.9	19.0		109.0	
10151- CAB	LTE-TDD (SC-FDMA, 50% RB, 20 MHz, QPSK)	X	6.27	66.1	21.2	9.28	116.8	$\pm 1.4 \%$
		Y	6.89	67.6	22.1		114.7	
		Z	6.69	66.0	21.0		116.4	
10154- CAC	LTE-FDD (SC-FDMA, 50% RB, 10 MHz, QPSK)	X	5.37	65.9	19.1	5.75	107.3	$\pm 1.2 \%$
		Y	5.98	67.2	19.9		143.3	
		Z	6.01	66.7	19.4		149.2	
10160- CAB	LTE-FDD (SC-FDMA, 50% RB, 15 MHz, QPSK)	X	5.76	66.2	19.2	5.82	109.5	$\pm 1.2 \%$
		Y	6.43	67.6	20.0		148.3	
		Z	6.05	65.6	18.7		107.5	
10169- CAB	LTE-FDD (SC-FDMA, 1 RB, 20 MHz, QPSK)	X	4.24	65.6	19.3	5.73	127.4	$\pm 0.9 \%$
		Y	4.54	66.4	19.8		120.4	
		Z	4.62	65.9	19.3		123.8	
10172- CAB	LTE-TDD (SC-FDMA, 1 RB, 20 MHz, QPSK)	X	4.91	68.0	22.7	9.21	126.7	$\pm 1.4 \%$
		Y	5.24	68.8	23.3		124.0	
		Z	5.35	68.1	22.5		125.0	
10175- CAC	LTE-FDD (SC-FDMA, 1 RB, 10 MHz, QPSK)	X	4.27	65.8	19.4	5.72	128.9	$\pm 0.9 \%$
		Y	4.52	66.2	19.7		121.2	
		Z	4.63	65.9	19.3		125.2	

10181-CAB	LTE-FDD (SC-FDMA, 1 RB, 15 MHz, QPSK)	X	4.26	65.7	19.4	5.72	125.9	±0.9 %
		Y	4.47	66.0	19.5		120.6	
		Z	4.60	65.7	19.2		123.0	
10237-CAB	LTE-TDD (SC-FDMA, 1 RB, 10 MHz, QPSK)	X	4.89	67.9	22.6	9.21	125.9	±1.7 %
		Y	5.26	69.0	23.4		123.8	
		Z	5.32	67.8	22.3		124.3	
10252-CAB	LTE-TDD (SC-FDMA, 50% RB, 10 MHz, QPSK)	X	6.04	66.8	21.7	9.24	149.2	±1.4 %
		Y	6.64	68.1	22.6		148.9	
		Z	6.48	66.5	21.4		147.5	
10267-CAB	LTE-TDD (SC-FDMA, 100% RB, 10 MHz, QPSK)	X	6.27	66.1	21.2	9.30	119.1	±1.4 %
		Y	6.88	67.4	22.0		115.9	
		Z	6.73	66.1	21.1		117.6	
10297-AAA	LTE-FDD (SC-FDMA, 50% RB, 20 MHz, QPSK)	X	5.71	66.0	19.2	5.81	110.7	±0.9 %
		Y	6.41	67.8	20.2		149.8	
		Z	5.98	65.7	18.9		107.9	
10311-AAA	LTE-FDD (SC-FDMA, 100% RB, 15 MHz, QPSK)	X	6.23	66.3	19.4	6.06	112.8	±0.9 %
		Y	6.51	66.6	19.5		107.4	
		Z	6.49	66.1	19.0		109.4	

The reported uncertainty of measurement is stated as the standard uncertainty of measurement multiplied by the coverage factor $k=2$, which for a normal distribution corresponds to a coverage probability of approximately 95%.

^A The uncertainties of Norm X,Y,Z do not affect the E^2 -field uncertainty inside TSL. (see Pages 6 and 7).

^B Numerical linearization parameter: uncertainty not required.

^E Uncertainty is determined using the max. deviation from linear response applying rectangular distribution and is expressed for the square of the field value.

DASY/EASY - Parameters of Probe: EX3DV4 - SN:7409

Calibration Parameter Determined in Head Tissue Simulating Media

f (MHz) ^C	Relative Permittivity ^F	Conductivity (S/m) ^F	ConvF X	ConvF Y	ConvF Z	Alpha ^G	Depth ^G (mm)	Unc (k=2)
750	41.9	0.89	10.73	10.73	10.73	0.62	0.83	± 12.0 %
835	41.5	0.90	10.04	10.04	10.04	0.45	0.93	± 12.0 %
1750	40.1	1.37	8.05	8.05	8.05	0.38	0.80	± 12.0 %
1900	40.0	1.40	7.69	7.69	7.69	0.41	0.80	± 12.0 %
2300	39.5	1.67	7.22	7.22	7.22	0.25	0.92	± 12.0 %
2450	39.2	1.80	6.90	6.90	6.90	0.30	0.93	± 12.0 %
2600	39.0	1.96	6.77	6.77	6.77	0.32	0.83	± 12.0 %

^C Frequency validity above 300 MHz of ± 100 MHz only applies for DASY v4.4 and higher (see Page 2), else it is restricted to ± 50 MHz. The uncertainty is the RSS of the ConvF uncertainty at calibration frequency and the uncertainty for the indicated frequency band. Frequency validity below 300 MHz is ± 10, 25, 40, 50 and 70 MHz for ConvF assessments at 30, 64, 128, 150 and 220 MHz respectively. Above 5 GHz frequency validity can be extended to ± 110 MHz.

^F At frequencies below 3 GHz, the validity of tissue parameters (ϵ and σ) can be relaxed to ± 10% if liquid compensation formula is applied to measured SAR values. At frequencies above 3 GHz, the validity of tissue parameters (ϵ and σ) is restricted to ± 5%. The uncertainty is the RSS of the ConvF uncertainty for indicated target tissue parameters.

^G Alpha/Depth are determined during calibration. SPEAG warrants that the remaining deviation due to the boundary effect after compensation is always less than ± 1% for frequencies below 3 GHz and below ± 2% for frequencies between 3-6 GHz at any distance larger than half the probe lip diameter from the boundary.

DASY/EASY - Parameters of Probe: EX3DV4 - SN:7409

Calibration Parameter Determined in Body Tissue Simulating Media

f (MHz) ^C	Relative Permittivity ^F	Conductivity (S/m) ^F	ConvF X	ConvF Y	ConvF Z	Alpha ^G	Depth ^G (mm)	Unc (k=2)
750	55.5	0.96	9.46	9.46	9.46	0.52	0.80	± 12.0 %
835	55.2	0.97	9.33	9.33	9.33	0.34	1.04	± 12.0 %
1750	53.4	1.49	7.72	7.72	7.72	0.44	0.80	± 12.0 %
1900	53.3	1.52	7.47	7.47	7.47	0.43	0.80	± 12.0 %
2300	52.9	1.81	7.22	7.22	7.22	0.36	0.85	± 12.0 %
2450	52.7	1.95	7.10	7.10	7.10	0.39	0.80	± 12.0 %
2600	52.5	2.16	6.83	6.83	6.83	0.39	0.86	± 12.0 %

^C Frequency validity above 300 MHz of ± 100 MHz only applies for DASY v4.4 and higher (see Page 2), else it is restricted to ± 50 MHz. The uncertainty is the RSS of the ConvF uncertainty at calibration frequency and the uncertainty for the indicated frequency band. Frequency validity below 300 MHz is ± 10, 25, 40, 50 and 70 MHz for ConvF assessments at 30, 64, 128, 150 and 220 MHz respectively. Above 5 GHz frequency validity can be extended to ± 110 MHz.

^F At frequencies below 3 GHz, the validity of tissue parameters (ϵ and σ) can be relaxed to ± 10% if liquid compensation formula is applied to measured SAR values. At frequencies above 3 GHz, the validity of tissue parameters (ϵ and σ) is restricted to ± 5%. The uncertainty is the RSS of the ConvF uncertainty for indicated target tissue parameters.

^G Alpha/Depth are determined during calibration. SPEAG warrants that the remaining deviation due to the boundary effect after compensation is always less than ± 1% for frequencies below 3 GHz and below ± 2% for frequencies between 3-6 GHz at any distance larger than half the probe tip diameter from the boundary.

Frequency Response of E-Field (TEM-Cell:ifi110 EXX, Waveguide: R22)

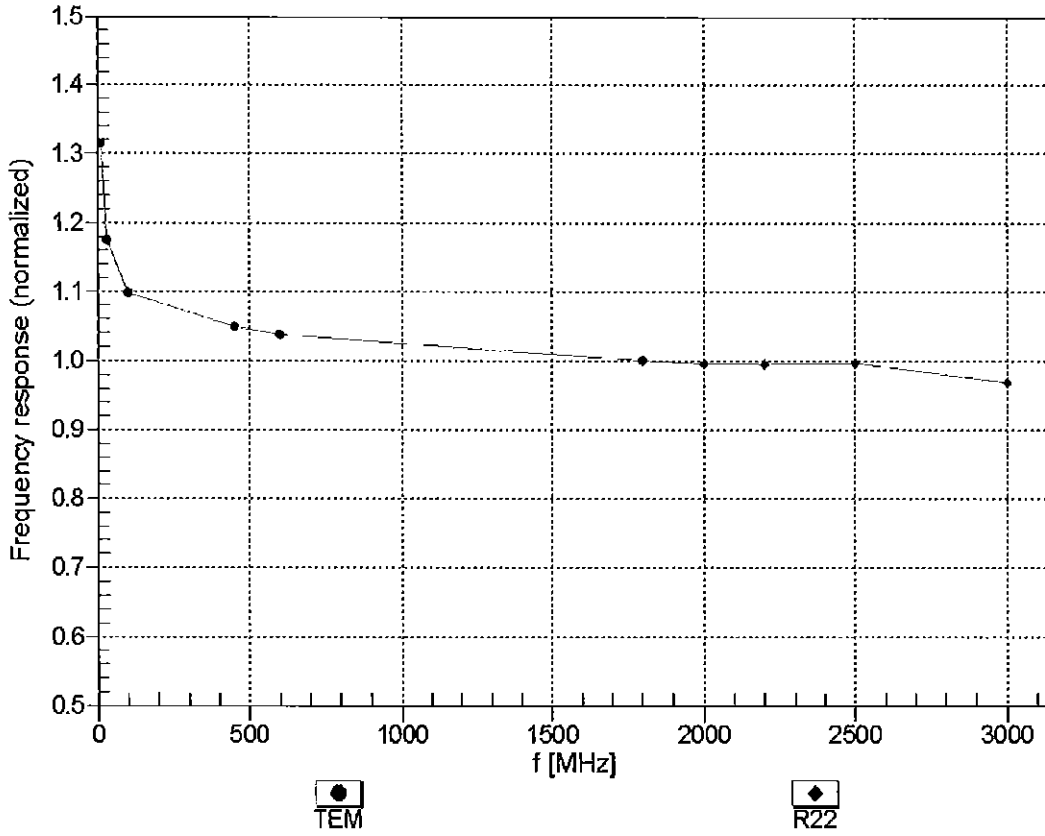

Uncertainty of Frequency Response of E-field: $\pm 6.3\%$ (k=2)

Receiving Pattern (ϕ), $\theta = 0^\circ$

f=600 MHz,TEM

f=1800 MHz,R22

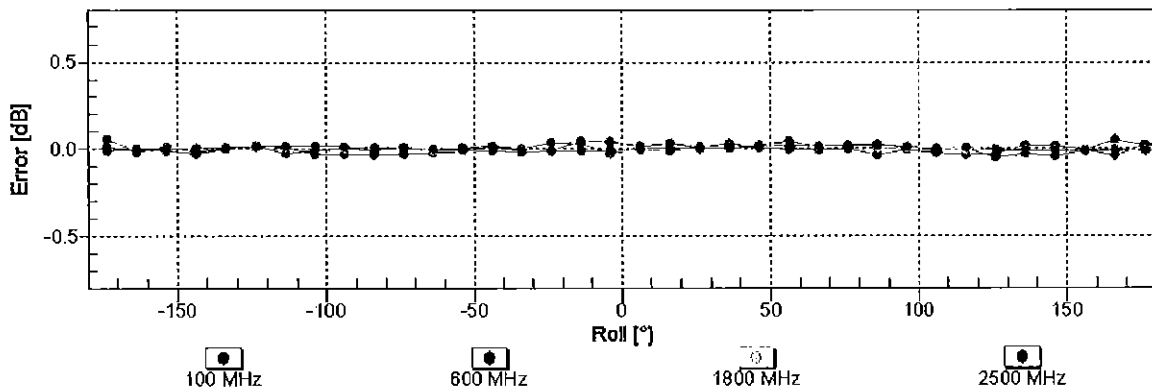
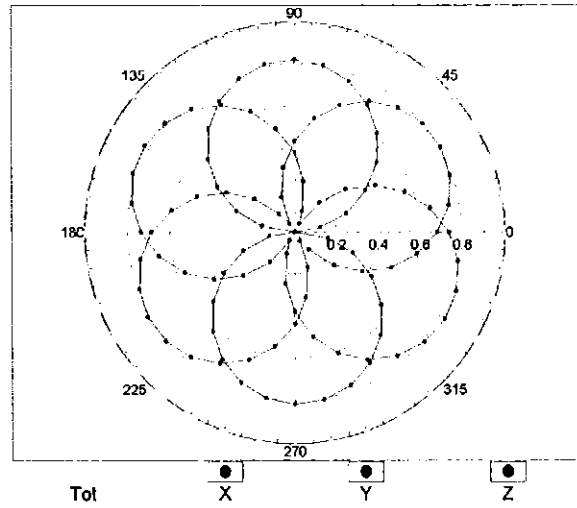
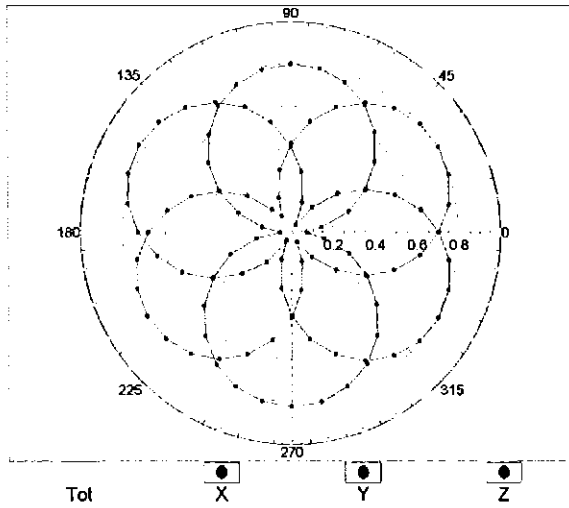

Uncertainty of Axial Isotropy Assessment: $\pm 0.5\%$ (k=2)

Dynamic Range f(SAR_{head}) (TEM cell , f_{eval}= 1900 MHz)

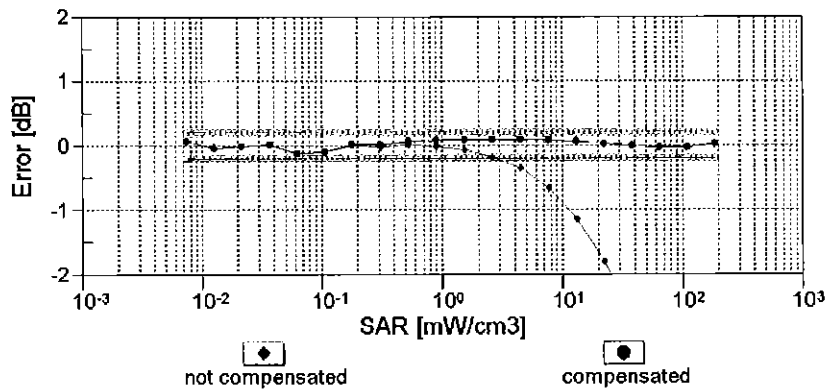
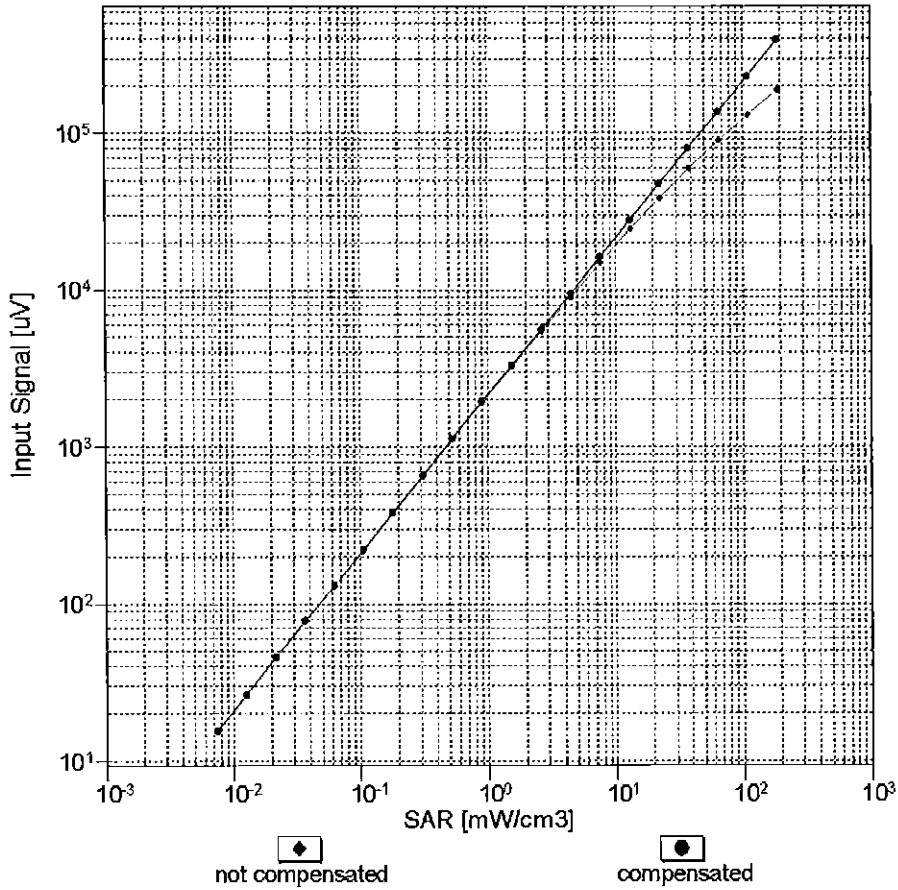

Uncertainty of Linearity Assessment: ± 0.6% (k=2)

Conversion Factor Assessment

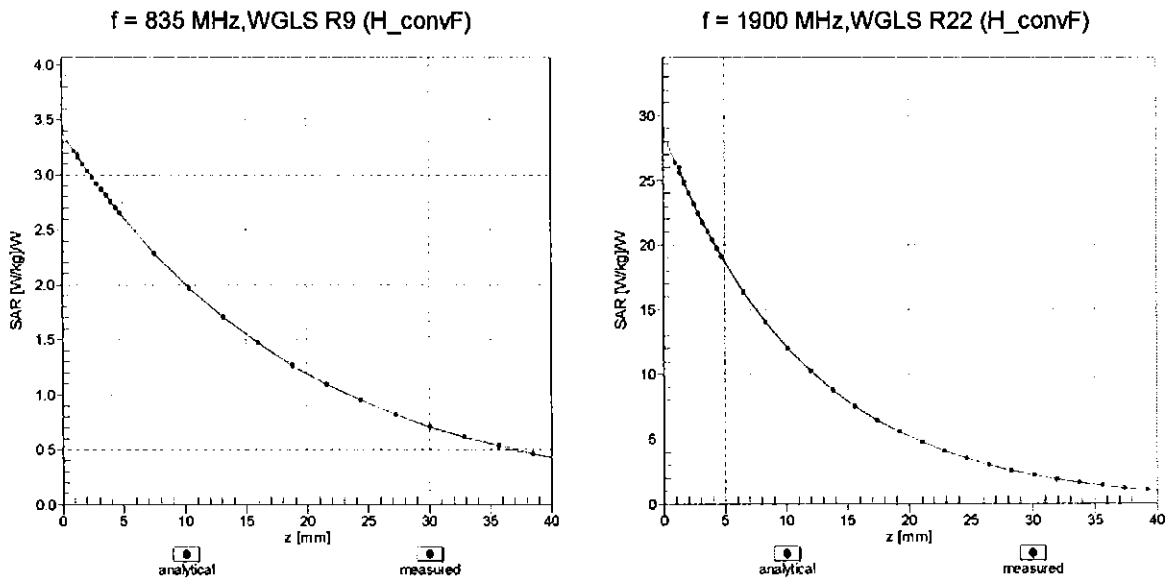

Deviation from Isotropy in Liquid Error (ϕ, ϑ), f = 900 MHz

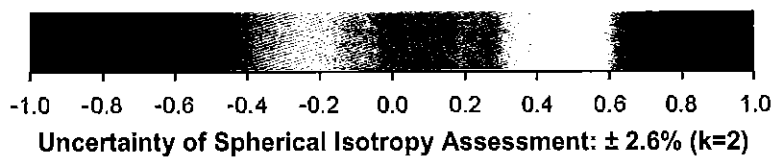
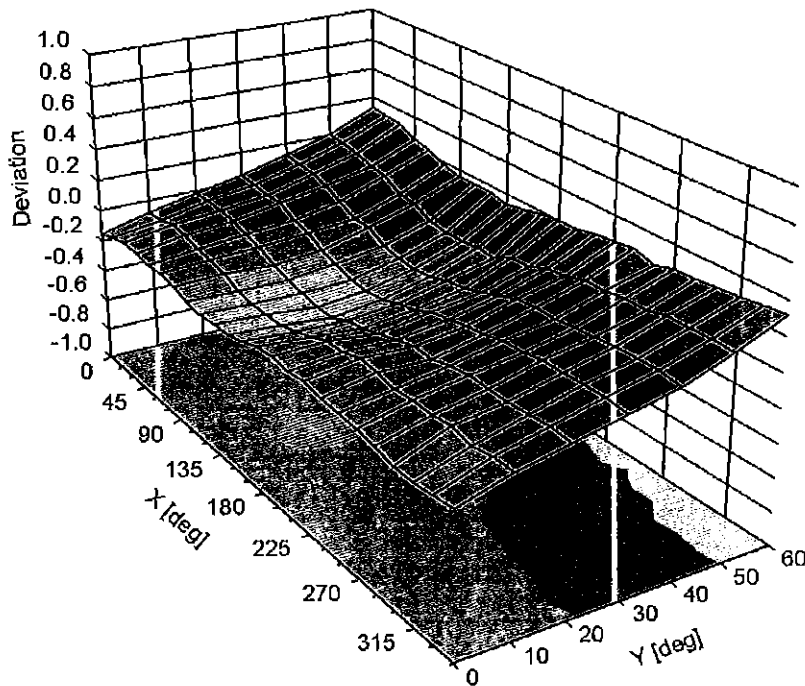

DASY/EASY - Parameters of Probe: EX3DV4 - SN:7409

Other Probe Parameters

Sensor Arrangement	Triangular
Connector Angle (°)	36.2
Mechanical Surface Detection Mode	enabled
Optical Surface Detection Mode	disabled
Probe Overall Length	337 mm
Probe Body Diameter	10 mm
Tip Length	9 mm
Tip Diameter	2.5 mm
Probe Tip to Sensor X Calibration Point	1 mm
Probe Tip to Sensor Y Calibration Point	1 mm
Probe Tip to Sensor Z Calibration Point	1 mm
Recommended Measurement Distance from Surface	1.4 mm



Accredited by the Swiss Accreditation Service (SAS)
The Swiss Accreditation Service is one of the signatories to the EA
Multilateral Agreement for the recognition of calibration certificates

Accreditation No.: **SCS 0108**

Client **PC Test**

Certificate No: **ES3-3318_Feb16**

CALIBRATION CERTIFICATE

Object: **ES3DV3 - SN:3318**

Calibration procedure(s): **QA CAL-01.v9, QA CAL-23.v5, QA CAL-25.v6
Calibration procedure for dosimetric E-field probes**

Calibration date: **February 19, 2016**

*BN ✓
05/01/2016*

This calibration certificate documents the traceability to national standards, which realize the physical units of measurements (SI).
The measurements and the uncertainties with confidence probability are given on the following pages and are part of the certificate.

All calibrations have been conducted in the closed laboratory facility: environment temperature (22 ± 3)°C and humidity < 70%.

Calibration Equipment used (M&TE critical for calibration)

Primary Standards	ID	Cal Date (Certificate No.)	Scheduled Calibration
Power meter E4419B	GB41293874	01-Apr-15 (No. 217-02128)	Mar-16
Power sensor E4412A	MY41498087	01-Apr-15 (No. 217-02128)	Mar-16
Reference 3 dB Attenuator	SN: S5054 (3c)	01-Apr-15 (No. 217-02129)	Mar-16
Reference 20 dB Attenuator	SN: S5277 (20x)	01-Apr-15 (No. 217-02132)	Mar-16
Reference 30 dB Attenuator	SN: S5129 (30b)	01-Apr-15 (No. 217-02133)	Mar-16
Reference Probe ES3DV2	SN: 3013	31-Dec-15 (No. ES3-3013_Dec15)	Dec-16
DAE4	SN: 660	23-Dec-15 (No. DAE4-660_Dec15)	Dec-16
Secondary Standards	ID	Check Date (in house)	Scheduled Check
RF generator HP 8648C	US3642U01700	4-Aug-99 (in house check Apr-13)	In house check: Apr-16
Network Analyzer HP 8753E	US37390585	18-Oct-01 (in house check Oct-15)	In house check: Oct-16

Calibrated by: **Jeton Kastri** (Name), **Laboratory Technician** (Function), [Signature]

Approved by: **Katja Pokovic** (Name), **Technical Manager** (Function), [Signature]

Issued: February 20, 2016

This calibration certificate shall not be reproduced except in full without written approval of the laboratory.



Accredited by the Swiss Accreditation Service (SAS)

The Swiss Accreditation Service is one of the signatories to the EA
Multilateral Agreement for the recognition of calibration certificates

Accreditation No.: **SCS 0108**

Glossary:

TSL	tissue simulating liquid
NORM _{x,y,z}	sensitivity in free space
ConvF	sensitivity in TSL / NORM _{x,y,z}
DCP	diode compression point
CF	crest factor (1/duty_cycle) of the RF signal
A, B, C, D	modulation dependent linearization parameters
Polarization φ	φ rotation around probe axis
Polarization ϑ	ϑ rotation around an axis that is in the plane normal to probe axis (at measurement center), i.e., $\vartheta = 0$ is normal to probe axis
Connector Angle	information used in DASY system to align probe sensor X to the robot coordinate system

Calibration is Performed According to the Following Standards:

- a) IEEE Std 1528-2013, "IEEE Recommended Practice for Determining the Peak Spatial-Averaged Specific Absorption Rate (SAR) in the Human Head from Wireless Communications Devices: Measurement Techniques", June 2013
- b) IEC 62209-1, "Procedure to measure the Specific Absorption Rate (SAR) for hand-held devices used in close proximity to the ear (frequency range of 300 MHz to 3 GHz)", February 2005
- c) IEC 62209-2, "Procedure to determine the Specific Absorption Rate (SAR) for wireless communication devices used in close proximity to the human body (frequency range of 30 MHz to 6 GHz)", March 2010
- d) KDB 865664, "SAR Measurement Requirements for 100 MHz to 6 GHz"

Methods Applied and Interpretation of Parameters:

- **NORM_{x,y,z}**: Assessed for E-field polarization $\vartheta = 0$ ($f \leq 900$ MHz in TEM-cell; $f > 1800$ MHz: R22 waveguide). NORM_{x,y,z} are only intermediate values, i.e., the uncertainties of NORM_{x,y,z} does not affect the E²-field uncertainty inside TSL (see below *ConvF*).
- **NORM(f)_{x,y,z}** = NORM_{x,y,z} * *frequency_response* (see Frequency Response Chart). This linearization is implemented in DASY4 software versions later than 4.2. The uncertainty of the frequency response is included in the stated uncertainty of *ConvF*.
- **DCP_{x,y,z}**: DCP are numerical linearization parameters assessed based on the data of power sweep with CW signal (no uncertainty required). DCP does not depend on frequency nor media.
- **PAR**: PAR is the Peak to Average Ratio that is not calibrated but determined based on the signal characteristics
- **A_{x,y,z}; B_{x,y,z}; C_{x,y,z}; D_{x,y,z}; VR_{x,y,z}; A, B, C, D** are numerical linearization parameters assessed based on the data of power sweep for specific modulation signal. The parameters do not depend on frequency nor media. VR is the maximum calibration range expressed in RMS voltage across the diode.
- **ConvF and Boundary Effect Parameters**: Assessed in flat phantom using E-field (or Temperature Transfer Standard for $f \leq 800$ MHz) and inside waveguide using analytical field distributions based on power measurements for $f > 800$ MHz. The same setups are used for assessment of the parameters applied for boundary compensation (alpha, depth) of which typical uncertainty values are given. These parameters are used in DASY4 software to improve probe accuracy close to the boundary. The sensitivity in TSL corresponds to NORM_{x,y,z} * *ConvF* whereby the uncertainty corresponds to that given for *ConvF*. A frequency dependent *ConvF* is used in DASY version 4.4 and higher which allows extending the validity from ± 50 MHz to ± 100 MHz.
- **Spherical isotropy (3D deviation from isotropy)**: in a field of low gradients realized using a flat phantom exposed by a patch antenna.
- **Sensor Offset**: The sensor offset corresponds to the offset of virtual measurement center from the probe tip (on probe axis). No tolerance required.
- **Connector Angle**: The angle is assessed using the information gained by determining the NORM_x (no uncertainty required).

Probe ES3DV3

SN:3318

Manufactured: January 10, 2012
Calibrated: February 19, 2016

Calibrated for DASY/EASY Systems
(Note: non-compatible with DASY2 system!)

DASY/EASY - Parameters of Probe: ES3DV3 - SN:3318

Basic Calibration Parameters

	Sensor X	Sensor Y	Sensor Z	Unc (k=2)
Norm ($\mu\text{V}/(\text{V}/\text{m})^2$) ^A	1.16	0.93	1.29	$\pm 10.1 \%$
DCP (mV) ^B	102.2	104.2	103.7	

Modulation Calibration Parameters

UID	Communication System Name		A dB	B dB $\sqrt{\mu\text{V}}$	C	D dB	VR mV	Unc ^F (k=2)
0	CW	X	0.0	0.0	1.0	0.00	199.2	$\pm 3.5 \%$
		Y	0.0	0.0	1.0		176.5	
		Z	0.0	0.0	1.0		194.6	
10010-CAA	SAR Validation (Square, 100ms, 10ms)	X	3.19	63.2	12.6	10.00	42.3	$\pm 1.4 \%$
		Y	19.74	82.9	18.6		35.5	
		Z	4.87	67.6	14.6		43.3	
10012-CAB	IEEE 802.11b WiFi 2.4 GHz (DSSS, 1 Mbps)	X	2.99	68.6	18.5	1.87	141.3	$\pm 0.9 \%$
		Y	3.46	71.1	19.6		145.1	
		Z	3.19	70.2	19.5		144.7	
10100-CAB	LTE-FDD (SC-FDMA, 100% RB, 20 MHz, QPSK)	X	6.30	67.0	19.4	5.67	128.2	$\pm 1.4 \%$
		Y	6.32	67.0	19.2		129.9	
		Z	6.36	67.5	19.8		131.3	
10103-CAB	LTE-TDD (SC-FDMA, 100% RB, 20 MHz, QPSK)	X	11.31	78.0	27.3	9.29	146.7	$\pm 3.5 \%$
		Y	9.35	72.8	24.3		141.3	
		Z	11.02	76.9	26.7		131.7	
10108-CAC	LTE-FDD (SC-FDMA, 100% RB, 10 MHz, QPSK)	X	6.22	66.7	19.4	5.80	126.2	$\pm 1.4 \%$
		Y	6.20	66.5	19.1		128.1	
		Z	6.27	67.1	19.7		131.1	
10151-CAB	LTE-TDD (SC-FDMA, 50% RB, 20 MHz, QPSK)	X	10.46	76.6	26.8	9.28	138.8	$\pm 3.3 \%$
		Y	8.80	72.0	24.0		134.3	
		Z	10.01	75.0	25.9		122.1	
10154-CAC	LTE-FDD (SC-FDMA, 50% RB, 10 MHz, QPSK)	X	6.12	67.0	19.6	5.75	146.0	$\pm 1.7 \%$
		Y	6.15	67.1	19.5		148.7	
		Z	5.95	66.5	19.4		127.4	
10160-CAB	LTE-FDD (SC-FDMA, 50% RB, 15 MHz, QPSK)	X	6.33	66.7	19.4	5.82	127.2	$\pm 1.4 \%$
		Y	6.33	66.6	19.2		128.2	
		Z	6.38	67.1	19.7		133.6	
10169-CAB	LTE-FDD (SC-FDMA, 1 RB, 20 MHz, QPSK)	X	5.10	67.2	20.0	5.73	147.9	$\pm 1.2 \%$
		Y	4.85	66.3	19.3		127.1	
		Z	4.97	66.7	19.8		133.9	
10172-CAB	LTE-TDD (SC-FDMA, 1 RB, 20 MHz, QPSK)	X	8.71	78.3	27.8	9.21	127.5	$\pm 3.0 \%$
		Y	7.52	74.8	25.7		144.7	
		Z	10.09	81.9	29.5		136.4	
10175-CAC	LTE-FDD (SC-FDMA, 1 RB, 10 MHz, QPSK)	X	5.09	67.2	20.0	5.72	146.9	$\pm 1.2 \%$
		Y	4.97	66.9	19.6		140.9	
		Z	4.95	66.6	19.7		133.1	

10181-CAB	LTE-FDD (SC-FDMA, 1 RB, 15 MHz, QPSK)	X	5.11	67.3	20.0	5.72	146.8	±1.2 %
		Y	5.03	67.2	19.8		147.0	
		Z	5.00	66.8	19.8		135.0	
10237-CAB	LTE-TDD (SC-FDMA, 1 RB, 10 MHz, QPSK)	X	8.73	78.3	27.8	9.21	126.7	±3.0 %
		Y	7.60	75.1	25.9		146.1	
		Z	10.76	83.8	30.4		143.4	
10252-CAB	LTE-TDD (SC-FDMA, 50% RB, 10 MHz, QPSK)	X	9.61	75.3	26.2	9.24	129.4	±3.3 %
		Y	8.55	72.3	24.3		143.1	
		Z	11.05	79.1	28.1		146.1	
10267-CAB	LTE-TDD (SC-FDMA, 100% RB, 10 MHz, QPSK)	X	10.44	76.5	26.8	9.30	137.7	±3.3 %
		Y	8.62	71.3	23.6		125.8	
		Z	10.24	75.6	26.2		125.3	
10297-AAA	LTE-FDD (SC-FDMA, 50% RB, 20 MHz, QPSK)	X	6.51	67.8	20.0	5.81	148.5	±1.7 %
		Y	6.42	67.3	19.6		144.3	
		Z	6.31	67.3	19.8		134.7	
10311-AAA	LTE-FDD (SC-FDMA, 100% RB, 15 MHz, QPSK)	X	6.80	67.4	19.9	6.06	128.6	±1.4 %
		Y	6.69	66.9	19.4		125.3	
		Z	6.91	68.0	20.3		140.1	

The reported uncertainty of measurement is stated as the standard uncertainty of measurement multiplied by the coverage factor $k=2$, which for a normal distribution corresponds to a coverage probability of approximately 95%.

^A The uncertainties of Norm X,Y,Z do not affect the E^2 -field uncertainty inside TSL (see Pages 6 and 7).

^B Numerical linearization parameter: uncertainty not required.

^E Uncertainty is determined using the max. deviation from linear response applying rectangular distribution and is expressed for the square of the field value.

DASY/EASY - Parameters of Probe: ES3DV3 - SN:3318

Calibration Parameter Determined in Head Tissue Simulating Media

f (MHz) ^C	Relative Permittivity ^F	Conductivity (S/m) ^F	ConvF X	ConvF Y	ConvF Z	Alpha ^G	Depth ^G (mm)	Unc (k=2)
750	41.9	0.89	6.48	6.48	6.48	0.54	1.35	± 12.0 %
835	41.5	0.90	6.23	6.23	6.23	0.70	1.21	± 12.0 %
1750	40.1	1.37	5.34	5.34	5.34	0.72	1.27	± 12.0 %
1900	40.0	1.40	5.13	5.13	5.13	0.80	1.18	± 12.0 %
2300	39.5	1.67	4.78	4.78	4.78	0.76	1.29	± 12.0 %
2450	39.2	1.80	4.57	4.57	4.57	0.59	1.49	± 12.0 %
2600	39.0	1.96	4.40	4.40	4.40	0.80	1.31	± 12.0 %

^C Frequency validity above 300 MHz of ± 100 MHz only applies for DASY v4.4 and higher (see Page 2), else it is restricted to ± 50 MHz. The uncertainty is the RSS of the ConvF uncertainty at calibration frequency and the uncertainty for the indicated frequency band. Frequency validity below 300 MHz is ± 10, 25, 40, 50 and 70 MHz for ConvF assessments at 30, 64, 128, 150 and 220 MHz respectively. Above 5 GHz frequency validity can be extended to ± 110 MHz.

^F At frequencies below 3 GHz, the validity of tissue parameters (ϵ and σ) can be relaxed to ± 10% if liquid compensation formula is applied to measured SAR values. At frequencies above 3 GHz, the validity of tissue parameters (ϵ and σ) is restricted to ± 5%. The uncertainty is the RSS of the ConvF uncertainty for indicated target tissue parameters.

^G Alpha/Depth are determined during calibration. SPEAG warrants that the remaining deviation due to the boundary effect after compensation is always less than ± 1% for frequencies below 3 GHz and below ± 2% for frequencies between 3-6 GHz at any distance larger than half the probe tip diameter from the boundary.

DASY/EASY - Parameters of Probe: ES3DV3 - SN:3318

Calibration Parameter Determined in Body Tissue Simulating Media

f (MHz) ^C	Relative Permittivity ^F	Conductivity (S/m) ^F	ConvF X	ConvF Y	ConvF Z	Alpha ^G	Depth ^G (mm)	Unc (k=2)
750	55.5	0.96	6.19	6.19	6.19	0.50	1.51	± 12.0 %
835	55.2	0.97	6.11	6.11	6.11	0.47	1.56	± 12.0 %
1750	53.4	1.49	5.02	5.02	5.02	0.49	1.55	± 12.0 %
1900	53.3	1.52	4.81	4.81	4.81	0.80	1.24	± 12.0 %
2300	52.9	1.81	4.55	4.55	4.55	0.80	1.27	± 12.0 %
2450	52.7	1.95	4.45	4.45	4.45	0.80	1.16	± 12.0 %
2600	52.5	2.16	4.18	4.18	4.18	0.80	1.13	± 12.0 %

^C Frequency validity above 300 MHz of ± 100 MHz only applies for DASY v4.4 and higher (see Page 2), else it is restricted to ± 50 MHz. The uncertainty is the RSS of the ConvF uncertainty at calibration frequency and the uncertainty for the indicated frequency band. Frequency validity below 300 MHz is ± 10, 25, 40, 50 and 70 MHz for ConvF assessments at 30, 64, 128, 150 and 220 MHz respectively. Above 5 GHz frequency validity can be extended to ± 110 MHz.

^F At frequencies below 3 GHz, the validity of tissue parameters (ϵ and σ) can be relaxed to ± 10% if liquid compensation formula is applied to measured SAR values. At frequencies above 3 GHz, the validity of tissue parameters (ϵ and σ) is restricted to ± 5%. The uncertainty is the RSS of the ConvF uncertainty for indicated target tissue parameters.

^G Alpha/Depth are determined during calibration. SPEAG warrants that the remaining deviation due to the boundary effect after compensation is always less than ± 1% for frequencies below 3 GHz and below ± 2% for frequencies between 3-6 GHz at any distance larger than half the probe tip diameter from the boundary.

Frequency Response of E-Field (TEM-Cell:ifi110 EXX, Waveguide: R22)

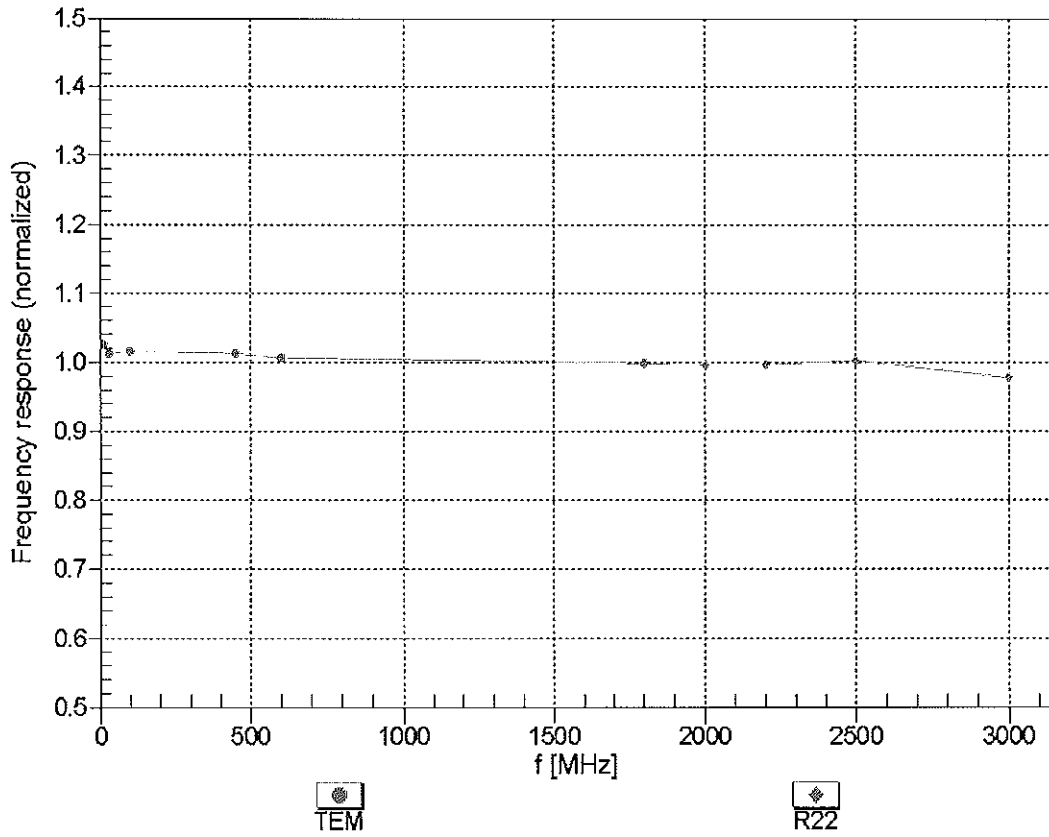

Uncertainty of Frequency Response of E-field: $\pm 6.3\%$ (k=2)

Receiving Pattern (ϕ), $\theta = 0^\circ$

f=600 MHz,TEM

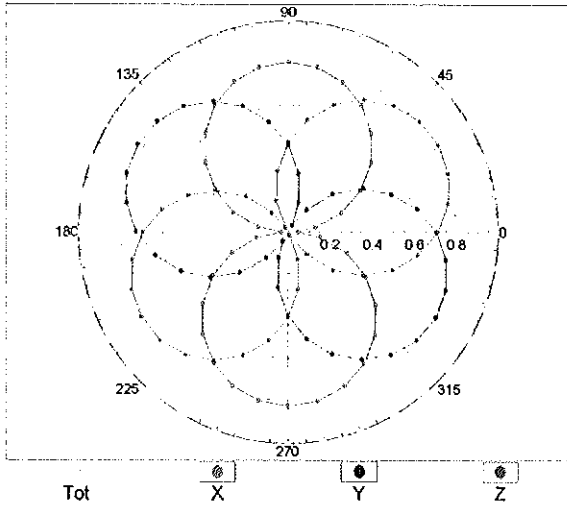

f=1800 MHz,R22

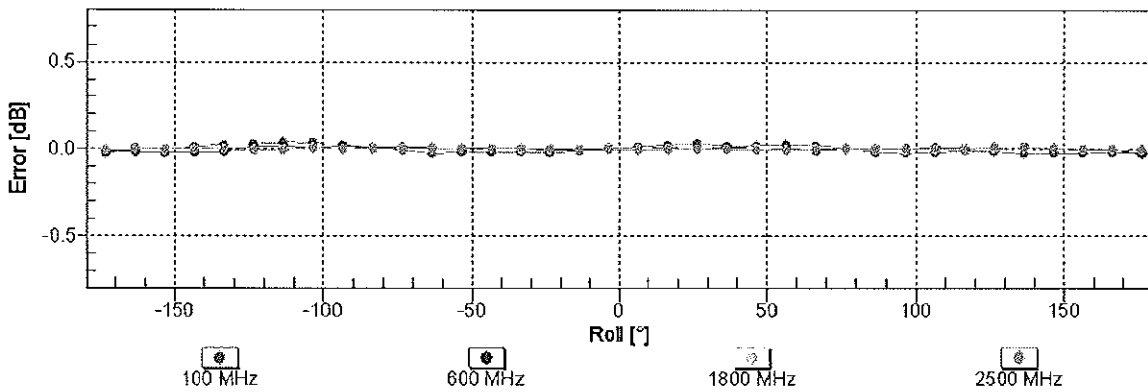
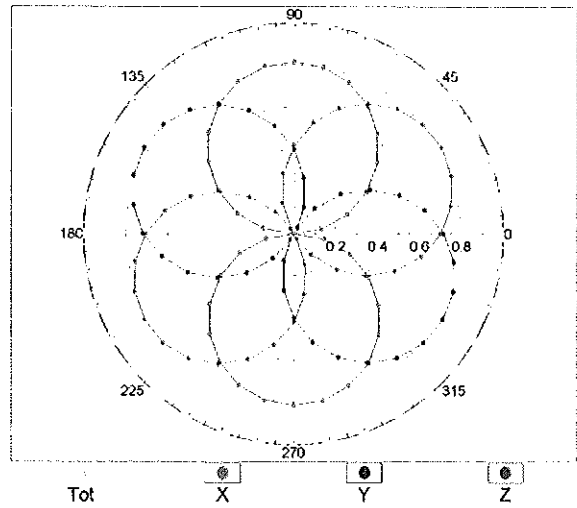

Uncertainty of Axial Isotropy Assessment: $\pm 0.5\%$ (k=2)

Dynamic Range $f(SAR_{head})$ (TEM cell , $f_{eval}= 1900$ MHz)

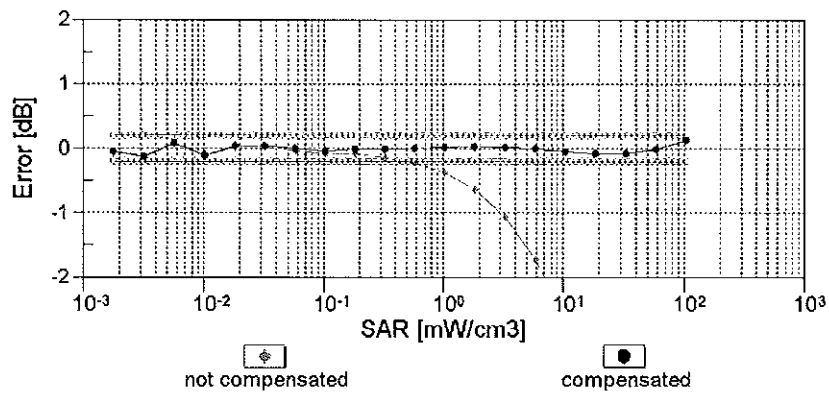
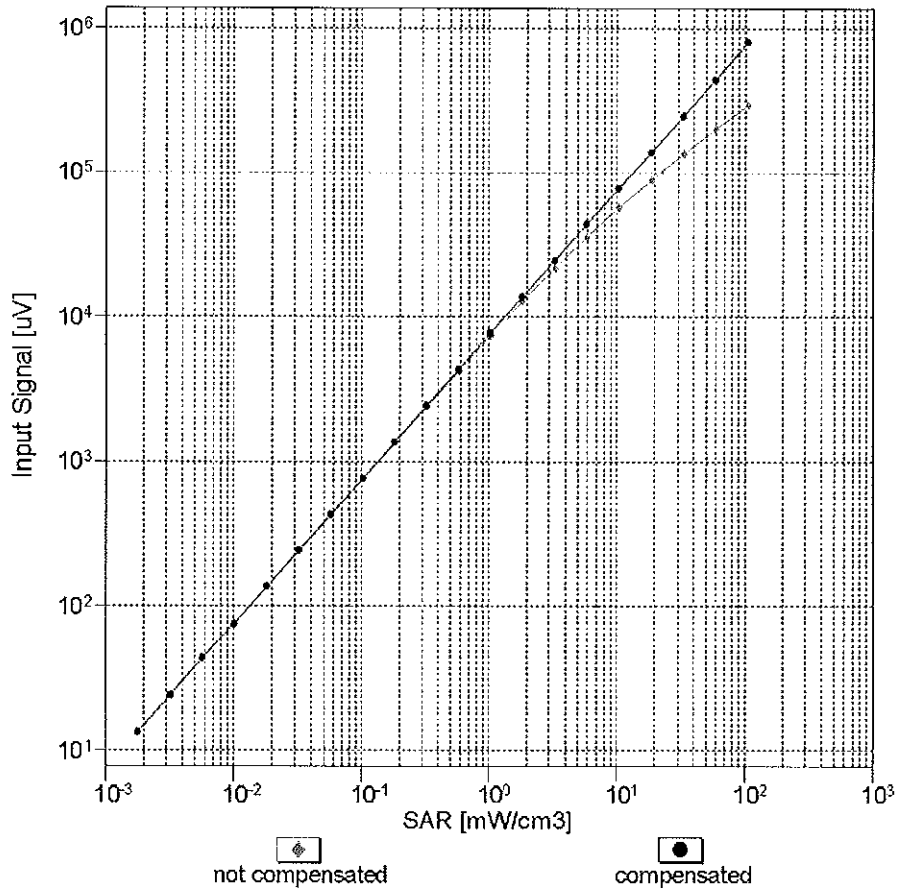

Uncertainty of Linearity Assessment: $\pm 0.6\%$ (k=2)

Conversion Factor Assessment

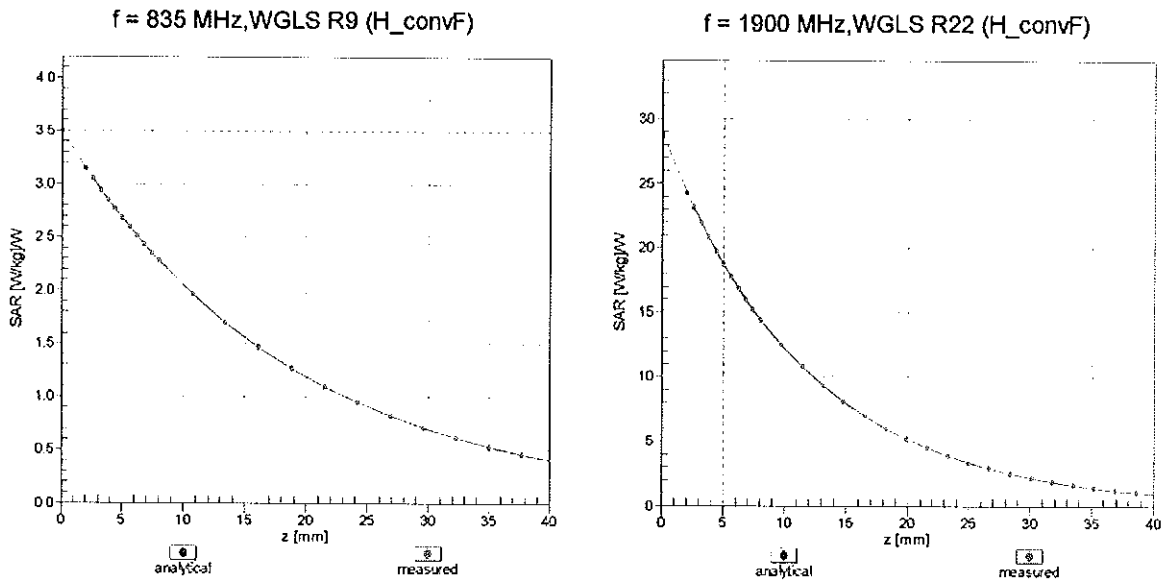

Deviation from Isotropy in Liquid Error (ϕ, ϑ), $f = 900$ MHz

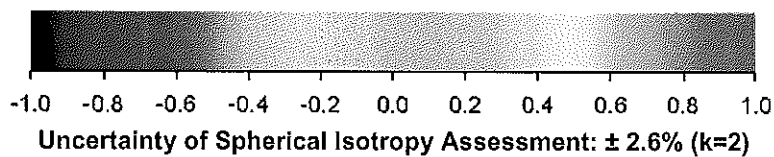
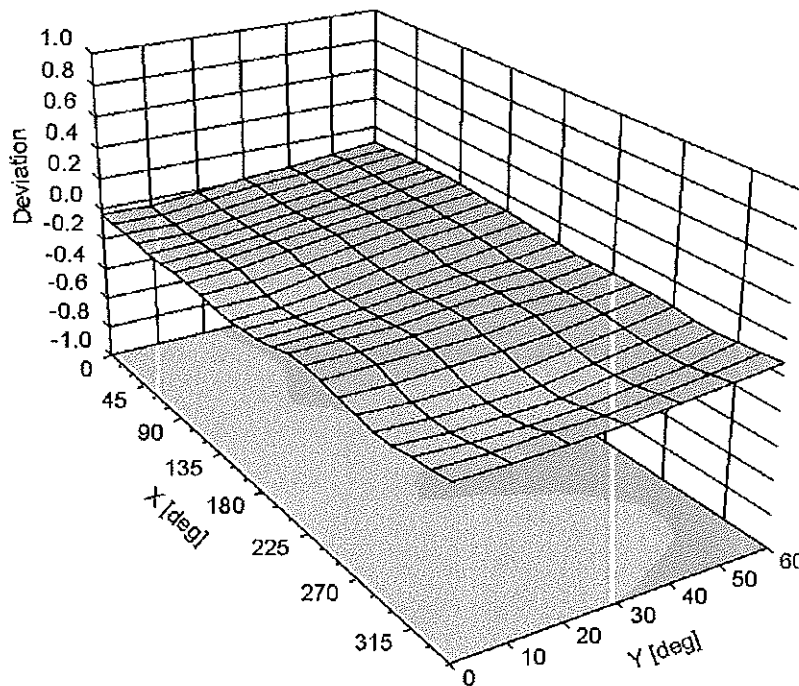

DASY/EASY - Parameters of Probe: ES3DV3 - SN:3318**Other Probe Parameters**

Sensor Arrangement	Triangular
Connector Angle (°)	76.5
Mechanical Surface Detection Mode	enabled
Optical Surface Detection Mode	disabled
Probe Overall Length	337 mm
Probe Body Diameter	10 mm
Tip Length	10 mm
Tip Diameter	4 mm
Probe Tip to Sensor X Calibration Point	2 mm
Probe Tip to Sensor Y Calibration Point	2 mm
Probe Tip to Sensor Z Calibration Point	2 mm
Recommended Measurement Distance from Surface	3 mm



Accredited by the Swiss Accreditation Service (SAS)
The Swiss Accreditation Service is one of the signatories to the EA
Multilateral Agreement for the recognition of calibration certificates

Accreditation No.: **SCS 0108**

Client **PC Test**

Certificate No: **ES3-3209_Mar16**

CALIBRATION CERTIFICATE

Object: **ES3DV3 - SN:3209**

Calibration procedure(s): **QA CAL-01.v9, QA CAL-23.v5, QA CAL-25.v6
Calibration procedure for dosimetric E-field probes**

Calibration date: **March 18, 2016**

*BN
3/30/2016*

This calibration certificate documents the traceability to national standards, which realize the physical units of measurements (SI).
The measurements and the uncertainties with confidence probability are given on the following pages and are part of the certificate.

All calibrations have been conducted in the closed laboratory facility: environment temperature (22 ± 3)°C and humidity < 70%.

Calibration Equipment used (M&TE critical for calibration)

Primary Standards	ID	Cal Date (Certificate No.)	Scheduled Calibration
Power meter E4419B	GB41293874	01-Apr-15 (No. 217-02128)	Mar-16
Power sensor E4412A	MY41498087	01-Apr-15 (No. 217-02128)	Mar-16
Reference 3 dB Attenuator	SN: S5054 (3c)	01-Apr-15 (No. 217-02129)	Mar-16
Reference 20 dB Attenuator	SN: S5277 (20x)	01-Apr-15 (No. 217-02132)	Mar-16
Reference 30 dB Attenuator	SN: S5129 (30b)	01-Apr-15 (No. 217-02133)	Mar-16
Reference Probe ES3DV2	SN: 3013	31-Dec-15 (No. ES3-3013_Dec15)	Dec-16
DAE4	SN: 660	23-Dec-15 (No. DAE4-660_Dec15)	Dec-16
Secondary Standards	ID	Check Date (in house)	Scheduled Check
RF generator HP 8648C	US3642U01700	4-Aug-99 (in house check Apr-13)	In house check: Apr-16
Network Analyzer HP 8753E	US37390585	18-Oct-01 (in house check Oct-15)	In house check: Oct-16

	Name	Function	Signature
Calibrated by:	Leif Klysner	Laboratory Technician	<i>Leif Klysner</i>
Approved by:	Katja Pokovic	Technical Manager	<i>Katja Pokovic</i>

Issued: March 22, 2016

This calibration certificate shall not be reproduced except in full without written approval of the laboratory.



Accredited by the Swiss Accreditation Service (SAS)

Accreditation No.: **SCS 0108**

The Swiss Accreditation Service is one of the signatories to the EA
Multilateral Agreement for the recognition of calibration certificates

Glossary:

TSL	tissue simulating liquid
NORM _{x,y,z}	sensitivity in free space
ConvF	sensitivity in TSL / NORM _{x,y,z}
DCP	diode compression point
CF	crest factor (1/duty_cycle) of the RF signal
A, B, C, D	modulation dependent linearization parameters
Polarization φ	φ rotation around probe axis
Polarization ϑ	ϑ rotation around an axis that is in the plane normal to probe axis (at measurement center), i.e., $\vartheta = 0$ is normal to probe axis
Connector Angle	information used in DASY system to align probe sensor X to the robot coordinate system

Calibration is Performed According to the Following Standards:

- IEEE Std 1528-2013, "IEEE Recommended Practice for Determining the Peak Spatial-Averaged Specific Absorption Rate (SAR) in the Human Head from Wireless Communications Devices: Measurement Techniques", June 2013
- IEC 62209-1, "Procedure to measure the Specific Absorption Rate (SAR) for hand-held devices used in close proximity to the ear (frequency range of 300 MHz to 3 GHz)", February 2005
- IEC 62209-2, "Procedure to determine the Specific Absorption Rate (SAR) for wireless communication devices used in close proximity to the human body (frequency range of 30 MHz to 6 GHz)", March 2010
- KDB 865664, "SAR Measurement Requirements for 100 MHz to 6 GHz"

Methods Applied and Interpretation of Parameters:

- NORM_{x,y,z}**: Assessed for E-field polarization $\vartheta = 0$ ($f \leq 900$ MHz in TEM-cell; $f > 1800$ MHz: R22 waveguide). NORM_{x,y,z} are only intermediate values, i.e., the uncertainties of NORM_{x,y,z} does not affect the E²-field uncertainty inside TSL (see below ConvF).
- NORM(f)_{x,y,z}** = NORM_{x,y,z} * frequency_response (see Frequency Response Chart). This linearization is implemented in DASY4 software versions later than 4.2. The uncertainty of the frequency response is included in the stated uncertainty of ConvF.
- DCP_{x,y,z}**: DCP are numerical linearization parameters assessed based on the data of power sweep with CW signal (no uncertainty required). DCP does not depend on frequency nor media.
- PAR**: PAR is the Peak to Average Ratio that is not calibrated but determined based on the signal characteristics
- A_{x,y,z}; B_{x,y,z}; C_{x,y,z}; D_{x,y,z}; VR_{x,y,z}**: A, B, C, D are numerical linearization parameters assessed based on the data of power sweep for specific modulation signal. The parameters do not depend on frequency nor media. VR is the maximum calibration range expressed in RMS voltage across the diode.
- ConvF and Boundary Effect Parameters**: Assessed in flat phantom using E-field (or Temperature Transfer Standard for $f \leq 800$ MHz) and inside waveguide using analytical field distributions based on power measurements for $f > 800$ MHz. The same setups are used for assessment of the parameters applied for boundary compensation (alpha, depth) of which typical uncertainty values are given. These parameters are used in DASY4 software to improve probe accuracy close to the boundary. The sensitivity in TSL corresponds to NORM_{x,y,z} * ConvF whereby the uncertainty corresponds to that given for ConvF. A frequency dependent ConvF is used in DASY version 4.4 and higher which allows extending the validity from ± 50 MHz to ± 100 MHz.
- Spherical isotropy (3D deviation from isotropy)**: in a field of low gradients realized using a flat phantom exposed by a patch antenna.
- Sensor Offset**: The sensor offset corresponds to the offset of virtual measurement center from the probe tip (on probe axis). No tolerance required.
- Connector Angle**: The angle is assessed using the information gained by determining the NORM_x (no uncertainty required).

Probe ES3DV3

SN:3209

Manufactured: October 14, 2008
Calibrated: March 18, 2016

Calibrated for DASYS/EASY Systems
(Note: non-compatible with DASYS2 system!)

DASY/EASY - Parameters of Probe: ES3DV3 - SN:3209

Basic Calibration Parameters

	Sensor X	Sensor Y	Sensor Z	Unc (k=2)
Norm ($\mu V / (V/m)^2$) ^A	1.33	1.31	1.12	$\pm 10.1\%$
DCP (mV) ^B	101.7	103.5	101.2	

Modulation Calibration Parameters

UID	Communication System Name		A dB	B dB $\sqrt{\mu V}$	C	D dB	VR mV	Unc ^E (k=2)
0	CW	X	0.0	0.0	1.0	0.00	220.0	$\pm 3.8\%$
		Y	0.0	0.0	1.0		213.1	
		Z	0.0	0.0	1.0		195.4	
10010-CAA	SAR Validation (Square, 100ms, 10ms)	X	2.09	61.8	11.1	10.00	43.7	$\pm 0.9\%$
		Y	2.54	63.7	12.3		42.4	
		Z	9.74	76.2	16.0		38.8	
10012-CAB	IEEE 802.11b WiFi 2.4 GHz (DSSS, 1 Mbps)	X	2.73	68.3	18.8	1.87	133.3	$\pm 0.7\%$
		Y	3.26	72.2	21.0		127.7	
		Z	2.80	68.4	18.6		116.7	
10100-CAB	LTE-FDD (SC-FDMA, 100% RB, 20 MHz, QPSK)	X	6.61	68.5	20.5	5.67	147.6	$\pm 1.4\%$
		Y	6.48	68.0	20.1		139.5	
		Z	6.30	67.2	19.6		127.7	
10103-CAB	LTE-TDD (SC-FDMA, 100% RB, 20 MHz, QPSK)	X	9.09	74.0	25.9	9.29	124.5	$\pm 2.2\%$
		Y	9.05	73.2	25.1		120.6	
		Z	8.51	71.7	24.5		107.7	
10108-CAC	LTE-FDD (SC-FDMA, 100% RB, 10 MHz, QPSK)	X	6.45	68.0	20.4	5.80	144.1	$\pm 1.4\%$
		Y	6.35	67.6	20.0		137.6	
		Z	6.17	66.8	19.5		124.8	
10151-CAB	LTE-TDD (SC-FDMA, 50% RB, 20 MHz, QPSK)	X	8.52	73.1	25.6	9.28	119.2	$\pm 2.5\%$
		Y	8.47	72.2	24.7		116.3	
		Z	9.20	75.3	26.7		148.4	
10154-CAC	LTE-FDD (SC-FDMA, 50% RB, 10 MHz, QPSK)	X	6.14	67.6	20.2	5.75	140.1	$\pm 1.4\%$
		Y	6.03	67.1	19.8		134.4	
		Z	5.89	66.4	19.4		121.9	
10160-CAB	LTE-FDD (SC-FDMA, 50% RB, 15 MHz, QPSK)	X	6.57	68.0	20.3	5.82	145.9	$\pm 1.4\%$
		Y	6.48	67.6	20.0		139.5	
		Z	6.32	67.0	19.6		126.7	
10169-CAB	LTE-FDD (SC-FDMA, 1 RB, 20 MHz, QPSK)	X	4.84	66.7	19.9	5.73	121.1	$\pm 1.2\%$
		Y	4.86	66.6	19.8		117.0	
		Z	5.16	67.8	20.4		148.7	
10172-CAB	LTE-TDD (SC-FDMA, 1 RB, 20 MHz, QPSK)	X	7.43	77.3	28.3	9.21	131.4	$\pm 1.9\%$
		Y	7.40	75.8	27.0		129.7	
		Z	6.83	73.7	26.0		116.1	
10175-CAC	LTE-FDD (SC-FDMA, 1 RB, 10 MHz, QPSK)	X	4.75	66.3	19.7	5.72	114.6	$\pm 0.9\%$
		Y	4.82	66.4	19.7		110.3	
		Z	5.16	67.8	20.4		147.4	

10181-CAB	LTE-FDD (SC-FDMA, 1 RB, 15 MHz, QPSK)	X	4.82	66.6	19.9	5.72	119.3	±0.9 %
		Y	4.79	66.2	19.6		110.0	
		Z	5.15	67.8	20.3		147.0	
10237-CAB	LTE-TDD (SC-FDMA, 1 RB, 10 MHz, QPSK)	X	7.37	76.9	28.1	9.21	130.4	±1.9 %
		Y	7.02	74.1	26.0		122.0	
		Z	6.83	73.6	25.9		115.6	
10252-CAB	LTE-TDD (SC-FDMA, 50% RB, 10 MHz, QPSK)	X	7.85	72.0	25.2	9.24	112.3	±2.5 %
		Y	7.74	70.8	24.1		104.5	
		Z	8.42	73.9	26.1		138.6	
10267-CAB	LTE-TDD (SC-FDMA, 100% RB, 10 MHz, QPSK)	X	8.43	72.7	25.4	9.30	116.9	±2.5 %
		Y	8.28	71.5	24.3		109.4	
		Z	9.17	75.2	26.7		147.6	
10297-AAA	LTE-FDD (SC-FDMA, 50% RB, 20 MHz, QPSK)	X	6.48	68.1	20.5	5.81	141.5	±1.4 %
		Y	6.32	67.4	20.0		136.8	
		Z	6.17	66.8	19.6		123.8	
10311-AAA	LTE-FDD (SC-FDMA, 100% RB, 15 MHz, QPSK)	X	7.07	68.8	20.8	6.06	146.9	±1.7 %
		Y	6.98	68.3	20.5		142.2	
		Z	6.77	67.5	20.0		128.8	

The reported uncertainty of measurement is stated as the standard uncertainty of measurement multiplied by the coverage factor $k=2$, which for a normal distribution corresponds to a coverage probability of approximately 95%.

^A The uncertainties of Norm X,Y,Z do not affect the E^2 -field uncertainty inside TSL (see Pages 6 and 7).

^B Numerical linearization parameter: uncertainty not required.

^E Uncertainty is determined using the max. deviation from linear response applying rectangular distribution and is expressed for the square of the field value.

DASY/EASY - Parameters of Probe: ES3DV3 - SN:3209

Calibration Parameter Determined in Head Tissue Simulating Media

f (MHz) ^C	Relative Permittivity ^F	Conductivity (S/m) ^F	ConvF X	ConvF Y	ConvF Z	Alpha ^G	Depth ^G (mm)	Unc (k=2)
750	41.9	0.89	6.60	6.60	6.60	0.47	1.59	± 12.0 %
835	41.5	0.90	6.20	6.20	6.20	0.80	1.19	± 12.0 %
1750	40.1	1.37	5.28	5.28	5.28	0.54	1.35	± 12.0 %
1900	40.0	1.40	5.14	5.14	5.14	0.71	1.21	± 12.0 %
2300	39.5	1.67	4.82	4.82	4.82	0.74	1.26	± 12.0 %
2450	39.2	1.80	4.63	4.63	4.63	0.55	1.50	± 12.0 %
2600	39.0	1.96	4.48	4.48	4.48	0.78	1.25	± 12.0 %

^C Frequency validity above 300 MHz of ± 100 MHz only applies for DASY v4.4 and higher (see Page 2), else it is restricted to ± 50 MHz. The uncertainty is the RSS of the ConvF uncertainty at calibration frequency and the uncertainty for the indicated frequency band. Frequency validity below 300 MHz is ± 10, 25, 40, 50 and 70 MHz for ConvF assessments at 30, 64, 128, 150 and 220 MHz respectively. Above 5 GHz frequency validity can be extended to ± 110 MHz.

^F At frequencies below 3 GHz, the validity of tissue parameters (ϵ and σ) can be relaxed to ± 10% if liquid compensation formula is applied to measured SAR values. At frequencies above 3 GHz, the validity of tissue parameters (ϵ and σ) is restricted to ± 5%. The uncertainty is the RSS of the ConvF uncertainty for indicated target tissue parameters.

^G Alpha/Depth are determined during calibration. SPEAG warrants that the remaining deviation due to the boundary effect after compensation is always less than ± 1% for frequencies below 3 GHz and below ± 2% for frequencies between 3-6 GHz at any distance larger than half the probe tip diameter from the boundary.

DASY/EASY - Parameters of Probe: ES3DV3 - SN:3209

Calibration Parameter Determined in Body Tissue Simulating Media

f (MHz) ^C	Relative Permittivity ^F	Conductivity (S/m) ^F	ConvF X	ConvF Y	ConvF Z	Alpha ^G	Depth (mm) ^G	Unc (k=2)
750	55.5	0.96	6.19	6.19	6.19	0.53	1.42	± 12.0 %
835	55.2	0.97	6.19	6.19	6.19	0.62	1.30	± 12.0 %
1750	53.4	1.49	4.99	4.99	4.99	0.51	1.54	± 12.0 %
1900	53.3	1.52	4.77	4.77	4.77	0.56	1.52	± 12.0 %
2300	52.9	1.81	4.44	4.44	4.44	0.75	1.26	± 12.0 %
2450	52.7	1.95	4.31	4.31	4.31	0.74	1.26	± 12.0 %
2600	52.5	2.16	4.11	4.11	4.11	0.80	1.20	± 12.0 %

^C Frequency validity above 300 MHz of ± 100 MHz only applies for DASY v4.4 and higher (see Page 2), else it is restricted to ± 50 MHz. The uncertainty is the RSS of the ConvF uncertainty at calibration frequency and the uncertainty for the indicated frequency band. Frequency validity below 300 MHz is ± 10, 25, 40, 50 and 70 MHz for ConvF assessments at 30, 64, 128, 150 and 220 MHz respectively. Above 5 GHz frequency validity can be extended to ± 110 MHz.

^F At frequencies below 3 GHz, the validity of tissue parameters (ϵ and σ) can be relaxed to ± 10% if liquid compensation formula is applied to measured SAR values. At frequencies above 3 GHz, the validity of tissue parameters (ϵ and σ) is restricted to ± 5%. The uncertainty is the RSS of the ConvF uncertainty for indicated target tissue parameters.

^G Alpha/Depth are determined during calibration. SPEAG warrants that the remaining deviation due to the boundary effect after compensation is always less than ± 1% for frequencies below 3 GHz and below ± 2% for frequencies between 3-6 GHz at any distance larger than half the probe tip diameter from the boundary.

Frequency Response of E-Field

(TEM-Cell:ifi110 EXX, Waveguide: R22)

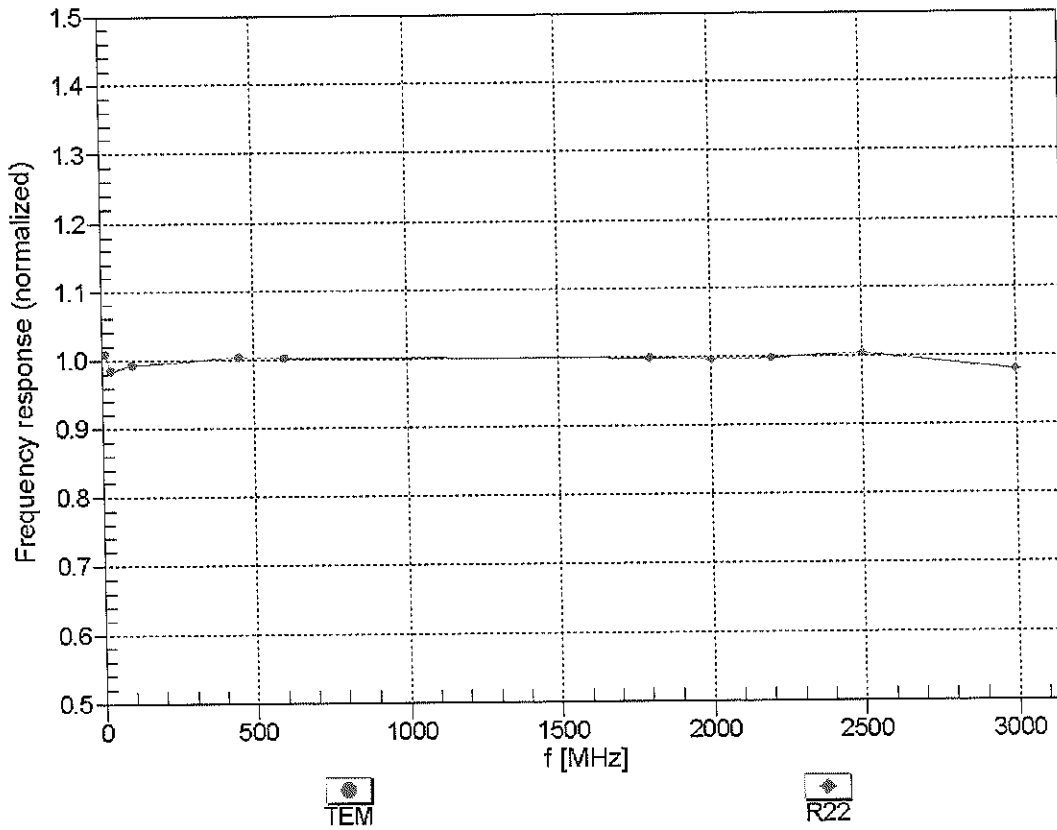

Uncertainty of Frequency Response of E-field: $\pm 6.3\%$ (k=2)

Receiving Pattern (ϕ), $\theta = 0^\circ$

f=600 MHz,TEM

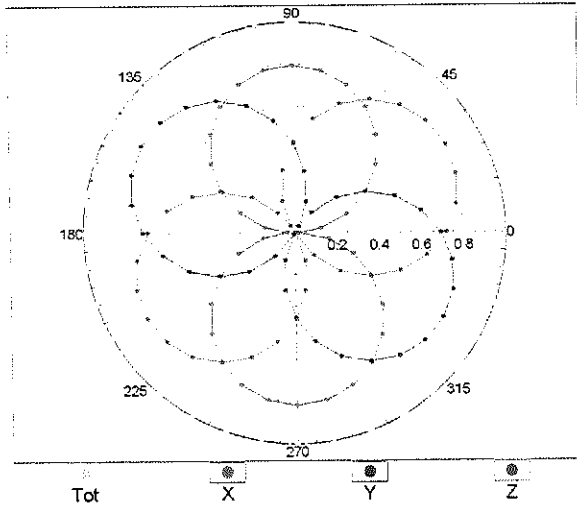

f=1800 MHz,R22

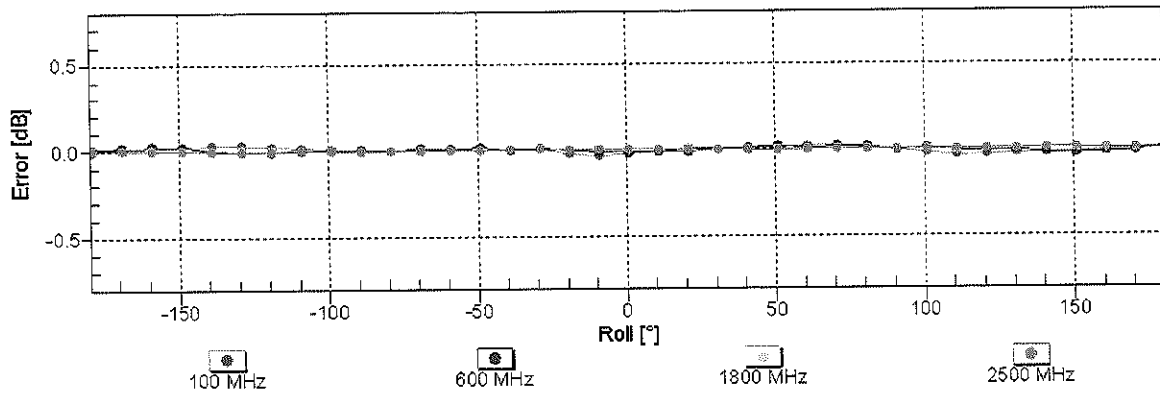
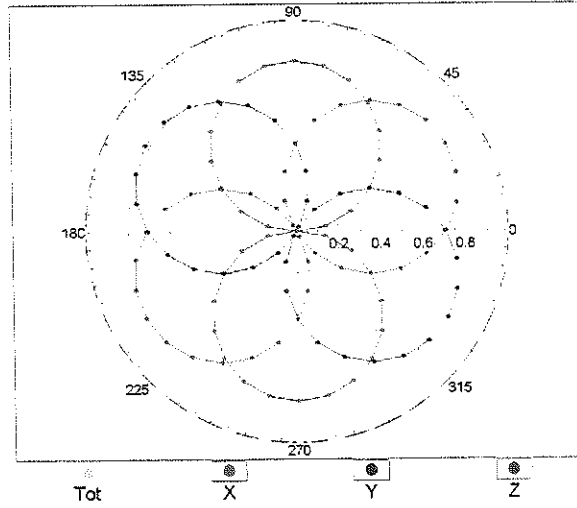

Uncertainty of Axial Isotropy Assessment: $\pm 0.5\%$ (k=2)

Dynamic Range f(SAR_{head}) (TEM cell , f_{eval}= 1900 MHz)

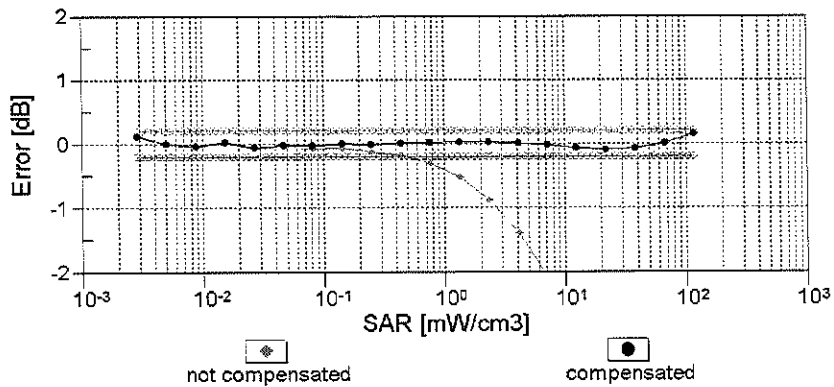
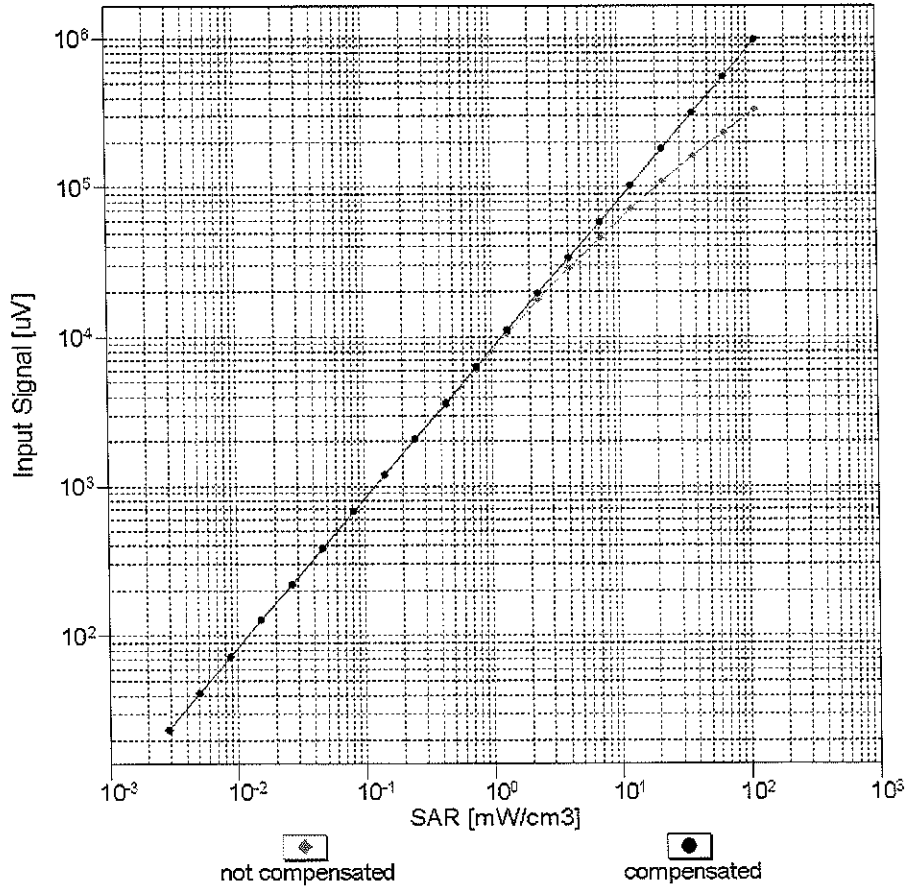

Uncertainty of Linearity Assessment: ± 0.6% (k=2)

Conversion Factor Assessment

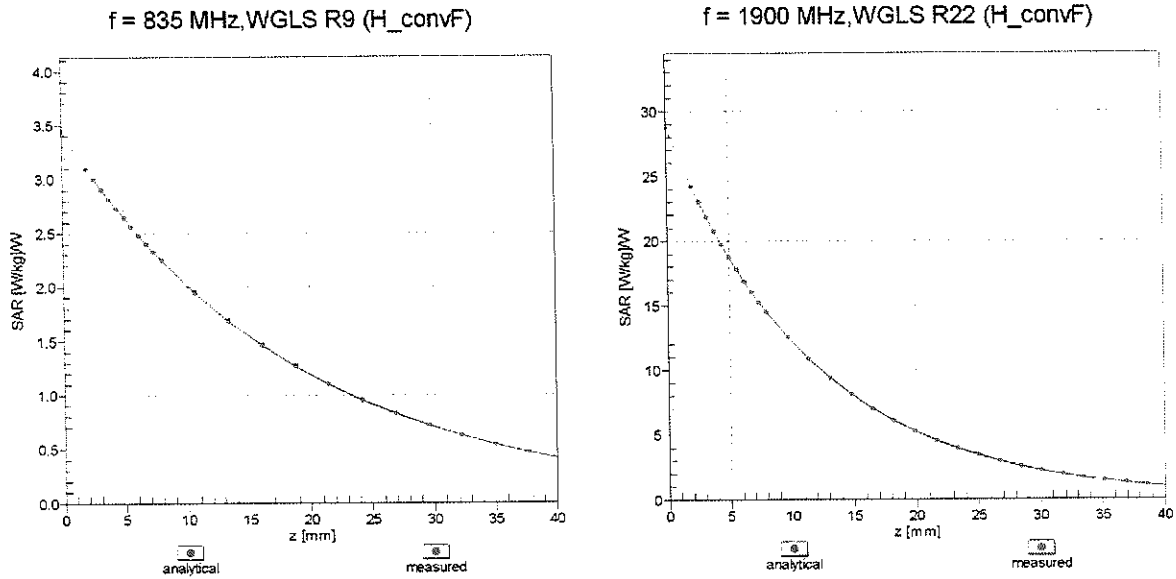

Deviation from Isotropy in Liquid Error (ϕ, θ), f = 900 MHz

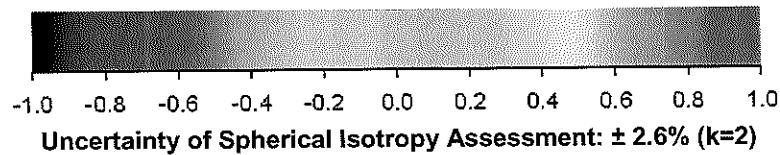
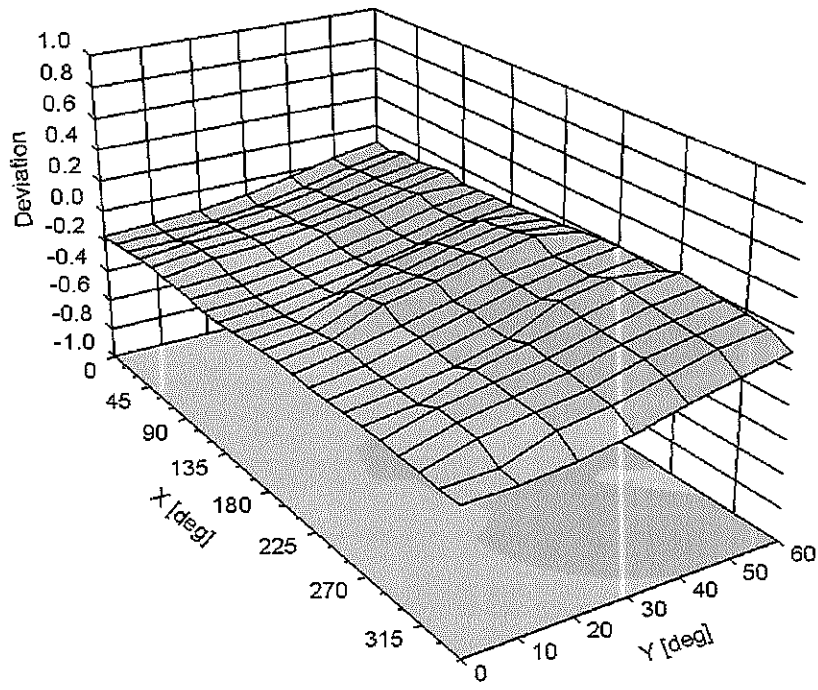

DASY/EASY - Parameters of Probe: ES3DV3 - SN:3209

Other Probe Parameters

Sensor Arrangement	Triangular
Connector Angle (°)	141
Mechanical Surface Detection Mode	enabled
Optical Surface Detection Mode	disabled
Probe Overall Length	337 mm
Probe Body Diameter	10 mm
Tip Length	10 mm
Tip Diameter	4 mm
Probe Tip to Sensor X Calibration Point	2 mm
Probe Tip to Sensor Y Calibration Point	2 mm
Probe Tip to Sensor Z Calibration Point	2 mm
Recommended Measurement Distance from Surface	3 mm

APPENDIX D: SAR TISSUE SPECIFICATIONS

Measurement Procedure for Tissue verification:



- 1) The network analyzer and probe system was configured and calibrated.
- 2) The probe was immersed in the tissue. The tissue was placed in a nonmetallic container. Trapped air bubbles beneath the flange were minimized by placing the probe at a slight angle.
- 3) The complex admittance with respect to the probe aperture was measured
- 4) The complex relative permittivity ϵ' can be calculated from the below equation (Pournaropoulos and Misra):

$$Y = \frac{j2\omega\epsilon_r\epsilon_0}{[\ln(b/a)]^2} \int_a^b \int_a^b \int_0^\pi \cos\phi' \frac{\exp[-j\omega r(\mu_0\epsilon_r'\epsilon_0)^{1/2}]}{r} d\phi' d\rho' d\rho$$

where Y is the admittance of the probe in contact with the sample, the primed and unprimed coordinates refer to source and observation points, respectively, $r^2 = \rho^2 + \rho'^2 - 2\rho\rho' \cos\phi'$, ω is the angular frequency, and $j = \sqrt{-1}$.

**Table D-I
Composition of the Tissue Equivalent Matter**

Frequency (MHz)	750	750	835	835	1750	1750	1900	1900	2450	2450
Tissue	Head	Body	Head	Body	Head	Body	Head	Body	Head	Body
Ingredients (% by weight)										
Bactericide			0.1	0.1						
DGBE					47	31	44.92	29.44		26.7
HEC			1	1						
NaCl			1.45	0.94	0.4	0.2	0.18	0.39		0.1
Sucrose			57	44.9						
Water			40.45	53.06	52.6	68.8	54.9	70.17		73.2

FCC ID: ZNFUS110		SAR EVALUATION REPORT		Approved by: Quality Manager
Test Dates: 12/21/16 - 01/05/17	DUT Type: Portable Handset			APPENDIX D: Page 1 of 4

2 Composition / Information on ingredients

The Item is composed of the following ingredients:

H ₂ O	Water, 35 – 58%
Sucrose	Sugar, white, refined, 40 – 60%
NaCl	Sodium Chloride, 0 – 6%
Hydroxyethyl-cellulose	Medium Viscosity (CAS# 9004-62-0), <0.3%
Preventol-D7	Preservative: aqueous preparation, (CAS# 55965-84-9), containing 5-chloro-2-methyl-3(2H)-isothiazolone and 2-methyl-3(2H)-isothiazolone, 0.1 – 0.7%

Relevant for safety; Refer to the respective Safety Data Sheet*.

**Figure D-1
Composition of 750 MHz Head and Body Tissue Equivalent Matter**

Note: 750MHz liquid recipes are proprietary SPEAG. Since the composition is approximate to the actual liquids utilized, the manufacturer tissue-equivalent liquid data sheets are provided below.

Measurement Certificate / Material Test

Item Name	Body Tissue Simulating Liquid (MSL750V2)
Product No.	SL AAM 075 AA (Charge: 150223-3)
Manufacturer	SPEAG

Measurement Method

TSL dielectric parameters measured using calibrated OCP probe.

Setup Validation

Validation results were within $\pm 2.5\%$ towards the target values of Methanol.

Target Parameters

Target parameters as defined in the IEEE 1528 and IEC 62209 compliance standards.

Test Condition

Ambient	Environment temperatur (22 ± 3)°C and humidity < 70%.
TSL Temperature	22°C
Test Date	25-Feb-15
Operator	IEN



Additional Information

TSL Density	1.212 g/cm ³
TSL Heat-capacity	3.006 kJ/(kg*K)

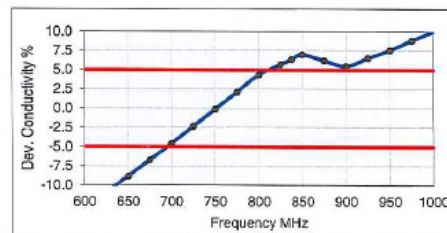
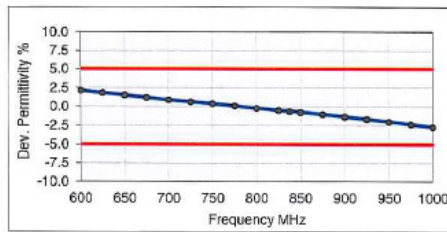
f [MHz]	Measured			Target		Diff. to Target [%]	
	HP-e'	HP-e''	sigma	eps	sigma	Δ-eps	Δ-sigma
600	57.3	24.76	0.83	56.1	0.95	2.2	-13.2
625	57.1	24.43	0.85	56.0	0.95	1.8	-11.0
650	56.8	24.09	0.87	55.9	0.96	1.5	-8.8
675	56.5	23.80	0.89	55.8	0.96	1.2	-6.7
700	56.2	23.51	0.92	55.7	0.96	0.9	-4.6
725	56.0	23.28	0.94	55.6	0.96	0.6	-2.4
750	55.7	23.06	0.96	55.5	0.96	0.4	-0.1
775	55.5	22.87	0.99	55.4	0.97	0.1	2.1
800	55.2	22.68	1.01	55.3	0.97	-0.2	4.4
825	55.0	22.52	1.03	55.2	0.98	-0.5	5.7
838	54.9	22.44	1.05	55.2	0.98	-0.6	6.3
850	54.8	22.36	1.06	55.2	0.99	-0.7	7.0
875	54.5	22.24	1.08	55.1	1.02	-1.0	6.2
900	54.3	22.12	1.11	55.0	1.05	-1.3	5.5
925	54.1	22.01	1.13	55.0	1.06	-1.6	6.5
950	53.9	21.89	1.16	54.9	1.08	-2.0	7.6
975	53.6	21.81	1.18	54.9	1.09	-2.3	8.8
1000	53.4	21.73	1.21	54.8	1.10	-2.7	10.1



**Figure D-2
750MHz Body Tissue Equivalent Matter**

FCC ID: ZNFUS110		SAR EVALUATION REPORT		Approved by: Quality Manager
Test Dates: 12/21/16 - 01/05/17	DUT Type: Portable Handset			APPENDIX D: Page 2 of 4

Measurement Certificate / Material Test

Item Name	Head Tissue Simulating Liquid (HSL750V2)
Product No.	SL AAH 075 AA (Charge: 150213-1)
Manufacturer	SPEAG

Measurement Method

TSL dielectric parameters measured using calibrated OCP probe.

Setup Validation

Validation results were within $\pm 2.5\%$ towards the target values of Methanol.

Target Parameters

Target parameters as defined in the IEEE 1528 and IEC 62209 compliance standards.

Test Condition

Ambient	Environment temperatur (22 ± 3)°C and humidity < 70%.
TSL Temperature	22°C
Test Date	18-Feb-15
Operator	IEN

Additional Information

TSL Density	1.284 g/cm ³
TSL Heat-capacity	2.701 kJ/(kg*K)

f [MHz]	Measured			Target		Diff.to Target [%]	
	HP-e'	HP-e''	sigma	eps	sigma	Δ-eps	Δ-sigma
600	44.6	22.42	0.75	42.7	0.88	4.5	-15.1
625	44.3	22.20	0.77	42.6	0.88	3.9	-12.7
650	43.9	21.98	0.79	42.5	0.89	3.3	-10.3
675	43.5	21.75	0.82	42.3	0.89	2.8	-8.0
700	43.1	21.53	0.84	42.2	0.89	2.2	-5.7
725	42.8	21.36	0.86	42.1	0.89	1.8	-3.3
750	42.5	21.22	0.89	41.9	0.89	1.3	-0.9
775	42.2	21.06	0.91	41.8	0.90	0.8	1.4
800	41.8	20.90	0.93	41.7	0.90	0.3	3.7
825	41.5	20.77	0.95	41.6	0.91	-0.2	5.1
838	41.4	20.71	0.96	41.5	0.91	-0.4	5.8
850	41.2	20.65	0.98	41.5	0.92	-0.7	6.6
875	40.9	20.53	1.00	41.5	0.94	-1.4	6.0
900	40.6	20.42	1.02	41.5	0.97	-2.1	5.4
925	40.4	20.32	1.05	41.5	0.98	-2.6	6.5
950	40.1	20.22	1.07	41.4	0.99	-3.2	7.5
975	39.8	20.14	1.09	41.4	1.00	-3.8	8.7
1000	39.5	20.05	1.12	41.3	1.01	-4.3	9.9

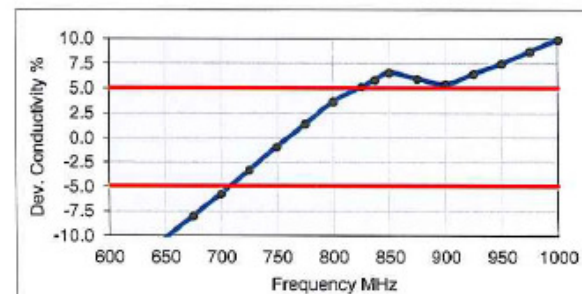
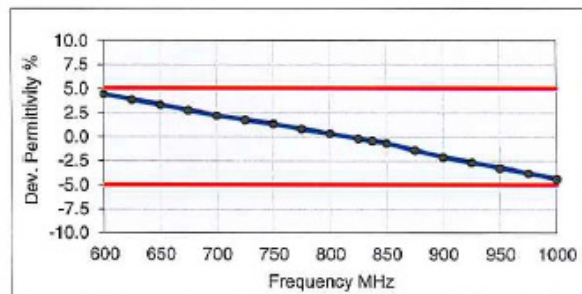



Figure D-3
750MHz Head Tissue Equivalent Matter

FCC ID: ZNFUS110		SAR EVALUATION REPORT		Approved by: Quality Manager
Test Dates: 12/21/16 - 01/05/17	DUT Type: Portable Handset			APPENDIX D: Page 3 of 4

2 Composition / Information on ingredients

The Item is composed of the following ingredients:

H ₂ O	Water, 52 – 75%
C ₈ H ₁₈ O ₃	Diethylene glycol monobutyl ether (DGBE), 25 – 48% (CAS-No. 112-34-5, EC-No. 203-961-6, EC-index-No. 603-096-00-8) Relevant for safety; Refer to the respective Safety Data Sheet*.
NaCl	Sodium Chloride, <1.0%

Figure D-4
Composition of 2.4 GHz Head Tissue Equivalent Matter

Note: 2.4 GHz head liquid recipes are proprietary SPEAG. Since the composition is approximate to the actual liquids utilized, the manufacturer tissue-equivalent liquid data sheets are provided below.

Measurement Certificate / Material Test

Item Name	Head Tissue Simulating Liquid (HSL2450V2)
Product No.	SL AAH 245 BA (Charge: 150206-3)
Manufacturer	SPEAG

Measurement Method

TSL dielectric parameters measured using calibrated OCP probe.

Setup Validation

Validation results were within $\pm 2.5\%$ towards the target values of Methanol.

Target Parameters

Target parameters as defined in the IEEE 1528 and IEC 62209 compliance standards.

Test Condition

Ambient	Environment temperatur (22 ± 3)°C and humidity < 70%.
TSL Temperature	23°C
Test Date	11-Feb-15
Operator	IEN

Additional Information

TSL Density	0.988 g/cm ³
TSL Heat-capacity	3.680 kJ/(kg*K)

f (MHz)	Measured			Target		Diff.to Target (%)	
	HP-e'	HP-e''	sigma	eps	sigma	Δ -eps	Δ -sigma
1900	40.4	11.89	1.26	40.0	1.40	1.0	-10.2
1925	40.3	11.98	1.28	40.0	1.40	0.7	-8.3
1950	40.2	12.07	1.31	40.0	1.40	0.4	-6.4
1975	40.1	12.15	1.34	40.0	1.40	0.2	-4.6
2000	40.0	12.23	1.36	40.0	1.40	-0.1	-2.8
2025	39.9	12.32	1.39	40.0	1.42	-0.2	-2.4
2050	39.8	12.41	1.42	39.9	1.44	-0.3	-2.0
2075	39.7	12.50	1.44	39.9	1.47	-0.4	-1.6
2100	39.6	12.59	1.47	39.8	1.49	-0.5	-1.2
2125	39.5	12.66	1.50	39.8	1.51	-0.7	-0.9
2150	39.4	12.73	1.52	39.7	1.53	-0.8	-0.7
2175	39.3	12.83	1.55	39.7	1.56	-0.9	-0.2
2200	39.2	12.92	1.58	39.6	1.58	-1.1	0.2
2225	39.1	13.00	1.61	39.6	1.60	-1.2	0.6
2250	39.0	13.08	1.64	39.6	1.62	-1.3	0.9
2275	38.9	13.17	1.67	39.5	1.64	-1.5	1.4
2300	38.8	13.26	1.70	39.5	1.67	-1.7	1.8
2325	38.7	13.34	1.73	39.4	1.69	-1.8	2.2
2350	38.6	13.42	1.75	39.4	1.71	-2.0	2.5
2375	38.5	13.50	1.78	39.3	1.73	-2.1	2.9
2400	38.4	13.58	1.81	39.3	1.76	-2.3	3.3
2425	38.3	13.65	1.84	39.2	1.78	-2.4	3.6
2450	38.2	13.73	1.87	39.2	1.80	-2.6	3.9
2475	38.1	13.80	1.90	39.2	1.83	-2.8	4.0
2500	38.0	13.87	1.93	39.1	1.85	-3.0	4.0
2525	37.9	13.90	1.95	39.1	1.88	-3.1	3.8
2550	37.8	13.93	1.98	39.1	1.91	-3.2	3.5
2575	37.7	14.05	2.01	39.0	1.94	-3.5	4.0
2600	37.6	14.17	2.05	39.0	1.96	-3.7	4.4
2625	37.4	14.23	2.08	39.0	1.99	-3.9	4.4
2650	37.3	14.29	2.11	38.9	2.02	-4.1	4.4
2675	37.2	14.37	2.14	38.9	2.05	-4.3	4.6
2700	37.1	14.45	2.17	38.9	2.07	-4.5	4.7

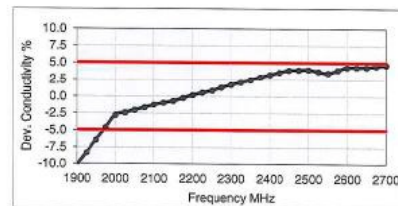
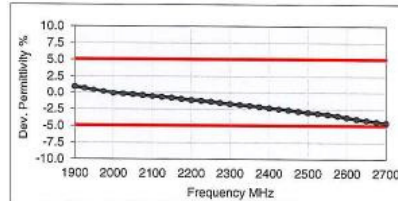



Figure D-5
2.4 GHz Head Tissue Equivalent Matter

FCC ID: ZNFUS110		SAR EVALUATION REPORT		Approved by: Quality Manager
Test Dates: 12/21/16 - 01/05/17	DUT Type: Portable Handset			APPENDIX D: Page 4 of 4

APPENDIX E: SAR SYSTEM VALIDATION



Per FCC KDB Publication 865664 D02v01r02, SAR system validation status should be documented to confirm measurement accuracy. The SAR systems (including SAR probes, system components and software versions) used for this device were validated against its performance specifications prior to the SAR measurements. Reference dipoles were used with the required tissue- equivalent media for system validation, according to the procedures outlined in FCC KDB Publication 865664 D01v01r04 and IEEE 1528-2013. Since SAR probe calibrations are frequency dependent, each probe calibration point was validated at a frequency within the valid frequency range of the probe calibration point, using the system that normally operates with the probe for routine SAR measurements and according to the required tissue-equivalent media.

A tabulated summary of the system validation status including the validation date(s), measurement frequencies, SAR probes and tissue dielectric parameters has been included.

Table E-I
SAR System Validation Summary

SAR SYSTEM #	FREQ. [MHz]	DATE	PROBE SN	PROBE TYPE	PROBE CAL. POINT		COND.	PERM.	CW VALIDATION			MOD. VALIDATION		
							(σ)	(ϵ_r)	SENSITIVITY	PROBE LINEARITY	PROBE ISOTROPY	MOD. TYPE	DUTY FACTOR	PAR
G	750	9/30/2016	3287	ES3DV3	750	Head	0.881	41.020	PASS	PASS	PASS	N/A	N/A	N/A
E	835	4/26/2016	7406	EX3DV4	835	Head	0.932	41.589	PASS	PASS	PASS	GMSK	PASS	N/A
E	1750	4/25/2016	7406	EX3DV4	1750	Head	1.390	40.075	PASS	PASS	PASS	N/A	N/A	N/A
G	1900	9/29/2016	3287	ES3DV3	1900	Head	1.395	38.777	PASS	PASS	PASS	GMSK	PASS	N/A
E	2450	5/2/2016	7406	EX3DV4	2450	Head	1.799	37.989	PASS	PASS	PASS	OFDM	N/A	PASS
J	750	3/9/2016	3318	ES3DV3	750	Body	0.956	53.115	PASS	PASS	PASS	N/A	N/A	N/A
H	835	4/7/2016	3319	ES3DV3	835	Body	1.000	54.246	PASS	PASS	PASS	GMSK	PASS	N/A
I	1750	12/19/2016	3209	ES3DV3	1750	Body	1.503	51.815	PASS	PASS	PASS	N/A	N/A	N/A
K	1900	5/24/2016	7409	EX3DV4	1900	Body	1.583	51.303	PASS	PASS	PASS	GMSK	PASS	N/A
G	2450	9/28/2016	3287	ES3DV3	2450	Body	2.030	50.891	PASS	PASS	PASS	OFDM	N/A	PASS

NOTE: While the probes have been calibrated for both CW and modulated signals, all measurements were performed using communication systems calibrated for CW signals only. Modulations in the table above represent test configurations for which the measurement system has been validated per FCC KDB Publication 865664 D01v01r04 for scenarios when CW probe calibrations are used with other signal types. SAR systems were validated for modulated signals with a periodic duty cycle, such as GMSK, or with a high peak to average ratio (>5 dB), such as OFDM according to FCC KDB Publication 865664 D01v01r04.

FCC ID: ZNFUS110		SAR EVALUATION REPORT		Approved by: Quality Manager
Test Dates: 12/21/16 - 01/05/17	DUT Type: Portable Handset	APPENDIX E: Page 1 of 1		