



HCT CO., LTD.

CERTIFICATE OF COMPLIANCE FCC Certification

Applicant Name: LG Electronics MobileComm U.S.A., Inc.	Date of Issue: February 01, 2012
Address: 10101 Old Grove Road, San Diego, CA 92131	Location: HCT CO., LTD., 105-1, Jangam-ri, Majang-Myeon, Icheon-si, Kyunggi-Do, Korea
	Test Report No.: HCTR1201FR28-1
	HCT FRN: 0005866421

FCC ID:	ZNFUD711
APPLICANT:	LG Electronics MobileComm U.S.A., Inc.

FCC Model(s):	UD711
Additional FCC Model(s):	LG-UD711, LGUD711
EUT Type:	PCS WCDMA Modem
FCC Classification:	PCS Licensed Transmitter (PCB)
FCC Rule Part(s):	§24, §2
Tx Frequency:	1 852.4 – 1 907.6 MHz (WCDMA1900)
Rx Frequency:	1 932.4 – 1 987.6 MHz (WCDMA1900)
Max. RF Output Power:	0.245 W EIRP WCDMA1900(23.89 dBm)
Emission Designator(s):	4M18F9W (WCDMA1900)

The measurements shown in this report were made in accordance with the procedures specified in §2.947. I assume full responsibility for the accuracy and completeness of these measurements, and for the qualifications of all persons taking them.

HCT CO., LTD. Certifies that no party to this application has subject to a denial of Federal benefits that includes FCC benefits pursuant to section 5301 of the Anti-Drug Abuse Act of 1998,21 U.S. C.853(a)

Hyo Sun Kwak
 Report prepared by
 : Hyo Sun Kwak
 Test engineer of RF Team

Chang Seok Choi
 Approved by
 : Chang Seok Choi
 Manager of RF Team

This report only responds to the tested sample and may not be reproduced, except in full, without written approval of the HCT Co., Ltd.

FCC CERTIFICATION REPORT			www.hct.co.kr
Test Report No. HCTR1201FR28-1	Date of Issue: February 01, 2012	EUT Type: PCS WCDMA Modem	FCC ID: ZNFUD711

Version

TEST REPORT NO.	DATE	DESCRIPTION
HCTR1201FR28	January 30, 2012	First Approval Report
HCTR1201FR28-1	February 01, 2012	Revise the 14 page.

Table of Contents

1. GENERAL INFORMATION		4
2. INTRODUCTION		5
2.1. EUT DESCRIPTION.....		5
2.2. MEASURING INSTRUMENT CALIBRATION.....		5
2.3. TEST FACILITY		5
3. DESCRIPTION OF TESTS		6
3.1 EFFECTIVE RADIATED POWER/EQUIVALENT ISOTROPIC RADIATED POWER.....		6
3.2 PEAK- TO- AVERAGE RATIO		7
3.3 OCCUPIED BANDWIDTH.		8
3.4 SPURIOUS AND HARMONIC EMISSIONS AT ANTENNA TERMINAL.....		9
3.5 RADIATED SPURIOUS AND HARMONIC EMISSIONS		10
3.6 FREQUENCY STABILITY / VARIATION OF AMBIENT TEMPERATURE		11
4. LIST OF TEST EQUIPMENT		12
5. SUMMARY OF TEST RESULTS		13
6. SAMPLE CALCULATION.....		14
7. TEST DATA		15
7.1 CONDUCTED OUTPUT POWER		15
7.2 PEAK-TO-AVERAGE RATIO		16
7.3 OCCUPIED BANDWIDTH		17
7.4 CONDUCTED SPURIOUS EMISSIONS		17
7.4.1 BAND EDGE.....		17
7.5 EQUIVALENT ISOTROPIC RADIATED POWER		18
7.6 RADIATED SPURIOUS EMISSIONS.....		19
7.6.1 RADIATED SPURIOUS EMISSIONS (WCDMA1900).....		19
7.7 FREQUENCY STABILITY / VARIATION OF AMBIENT TEMPERATURE		20
7.7.1 FREQUENCY STABILITY (WCDMA1900)		20
8. TEST PLOTS.....		21

FCC CERTIFICATION REPORT			www.hct.co.kr
Test Report No. HCTR1201FR28-1	Date of Issue: February 01, 2012	EUT Type: PCS WCDMA Modem	FCC ID: ZNFUD711



MEASUREMENT REPORT

1. GENERAL INFORMATION

Applicant Name: LG Electronics MobileComm U.S.A., Inc.
Address: 10101 Old Grove Road, San Diego, CA 92131
FCC ID: ZNFUD711
Application Type: Certification
FCC Classification: PCS Licensed Transmitter (PCB)
FCC Rule Part(s): §24, §2
EUT Type: PCS WCDMA Modem
FCC Model(s): UD711
Additional FCC Model(s): LG-UD711, LGUD711
Tx Frequency: 1 852.4 – 1 907.6 MHz (WCDMA1900)
Rx Frequency: 1 932.4 – 1 987.6 MHz (WCDMA1900)
Max. RF Output Power: 0.245 W EIRP WCDMA1900(23.89 dBm)
Emission Designator(s): 4M18F9W (WCDMA1900)
Antenna Specification Manufacturer: KOMA-TECH Co., Ltd.
Antenna type: Internal Antenna
Peak Gain: 0.20dBi
Date(s) of Tests: December 26, 2011 ~ January 04, 2012

FCC CERTIFICATION REPORT			www.hct.co.kr
Test Report No. HCTR1201FR28-1	Date of Issue: February 01, 2012	EUT Type: PCS WCDMA Modem	FCC ID: ZNFUD711

2. INTRODUCTION

2.1. EUT DESCRIPTION

The LG Electronics MobileComm U.S.A., Inc. UD711 PCS WCDMA Modem consists of WCDMA1900, HSDPA, HSUPA.

2.2. MEASURING INSTRUMENT CALIBRATION

The measuring equipment, which was utilized in performing the tests documented herein, has been calibrated in accordance with the manufacturer's recommendations for utilizing calibration equipment, which is traceable to recognized national standards.

2.3. TEST FACILITY

The SAC(Semi-Anechoic Chamber) and conducted measurement facility used to collect the radiated data are located at the 105-1, Jangam-ri , Majang-Myeon, Icheon-si, 467-811, KOREA.

The site is constructed in conformance with the requirements of ANSI C63.4 and CISPR Publication 22. Detailed description of test facility was submitted to the Commission and accepted dated March 02, 2011 (Registration Number: 90661)

FCC CERTIFICATION REPORT			www.hct.co.kr
Test Report No. HCTR1201FR28-1	Date of Issue: February 01, 2012	EUT Type: PCS WCDMA Modem	FCC ID: ZNFUD711

3. DESCRIPTION OF TESTS

3.1 EFFECTIVE RADIATED POWER/EQUIVALENT ISOTROPIC RADIATED POWER

Test Set-up

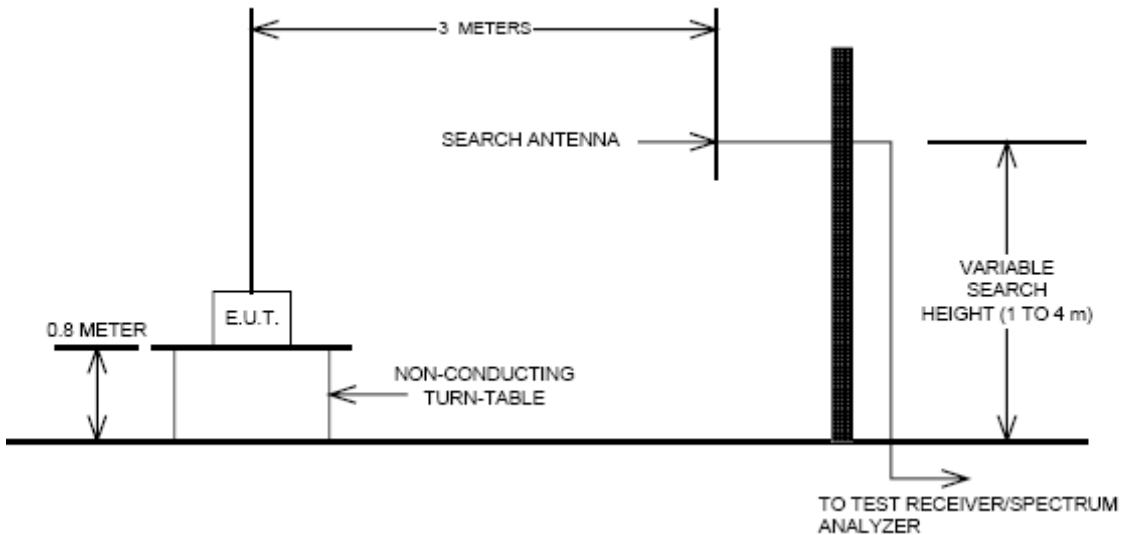

Test Procedure

Radiated emission measurements were performed at an SAC(Semi-Anechoic Chamber)

The equipment under test is placed on a non-conductive styrofoam resin table 3-meters from the receive antenna. A styrofoam turntable was rotated 360° and the receiving antenna scanned from 1-4m in order to capture the maximum emission. A half wave dipole was substituted in place of the EUT. This dipole antenna was driven by a signal generator and the previously recorded signal was duplicated.

The maximum EIRP was calculated by adding the forward power to the calibrated source plus its appropriate gain value. These steps were carried out with the receiving antenna in both vertical and horizontal polarization. For readings above 1GHz, the above procedure is repeated using horn antennas and the difference between the gain of the horn and an isotropic antenna are taken into consideration.

FCC CERTIFICATION REPORT			www.hct.co.kr
Test Report No. HCTR1201FR28-1	Date of Issue: February 01, 2012	EUT Type: PCS WCDMA Modem	FCC ID: ZNFUD711



3.2 PEAK- TO- AVERAGE RATIO

A peak to average ratio measurement is performed at the conducted port of the EUT. For CDMA and WCDMA signals, the spectrum analyzers Complementary Cumulative Distribution Function (CCDF) measurement profile is used to determine the largest deviation between the average and the peak power of the EUT in a given bandwidth. The CCDF curve shows how much time the peak waveform spends at or above a given average power level. The percent of time the signal spends at or above the level defines the probability for that particular power level. For GSM signals, an average and a peak trace are used on a

spectrum analyzer to determine the largest deviation between the average and the peak power of the EUT in a bandwidth greater than the emission bandwidth. Plots of the EUT's Peak- to- Average Ratio are shown herein.

FCC CERTIFICATION REPORT			www.hct.co.kr
Test Report No. HCTR1201FR28-1	Date of Issue: February 01, 2012	EUT Type: PCS WCDMA Modem	FCC ID: ZNFUD711

3.3 OCCUPIED BANDWIDTH.

Test set-up

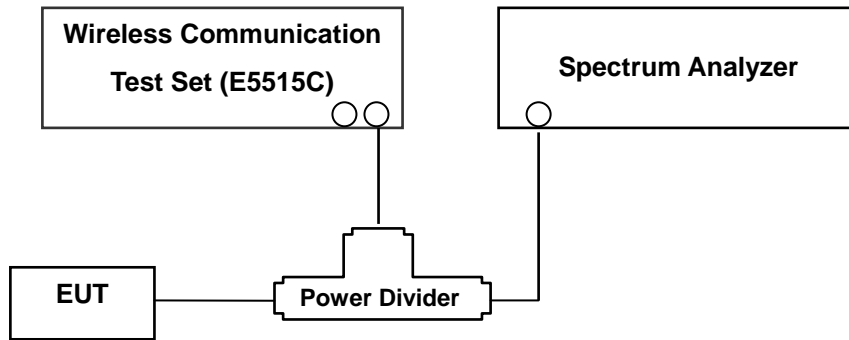

(Configuration of conducted Emission measurement)
Test Procedure

The EUT was setup to maximum output power at its lowest channel. The occupied bandwidth was measured using a spectrum analyzer. The measurements are repeated for the highest and a middle channel. The EUT's occupied bandwidth is measured as the width of the signal between two points, one below the carrier center frequency and one above the carrier frequency, outside of which all emissions are attenuated at least 26 dB below the transmitter power. Plots of the EUT's occupied bandwidth are shown herein.

FCC CERTIFICATION REPORT			www.hct.co.kr
Test Report No. HCTR1201FR28-1	Date of Issue: February 01, 2012	EUT Type: PCS WCDMA Modem	FCC ID: ZNFUD711

3.4 SPURIOUS AND HARMONIC EMISSIONS AT ANTENNA TERMINAL.

Test Procedure

The level of the carrier and the various conducted spurious and harmonic frequencies is measured by means of a calibrated spectrum analyzer.

The EUT was setup to maximum output power at its lowest channel. The Resolution BW of the analyzer is set to 1 % of the emission bandwidth to show compliance with the – 13 dBm limit, in the 1 MHz bands immediately outside and adjacent to the edge of the frequency block. The 1 MHz RBW was used to scan from 10 MHz to 10 GHz. (GSM1900 Mode: 10 MHz to 20 GHz). A display line was placed at – 13 dBm to show compliance. The high, lowest and a middle channel were tested for out of band measurements.

- Band Edge Requirement : In the 1MHz bands immediately outside and adjacent to the frequency block, a resolution bandwidth of at least 1 percent of the emission bandwidth of the fundamental emission of the transmitter may be employed to measure the out of band Emissions. Limit, -13dBm.

FCC CERTIFICATION REPORT			www.hct.co.kr
Test Report No. HCTR1201FR28-1	Date of Issue: February 01, 2012	EUT Type: PCS WCDMA Modem	FCC ID: ZNFUD711

3.5 RADIATED SPURIOUS AND HARMONIC EMISSIONS

Test Set-up

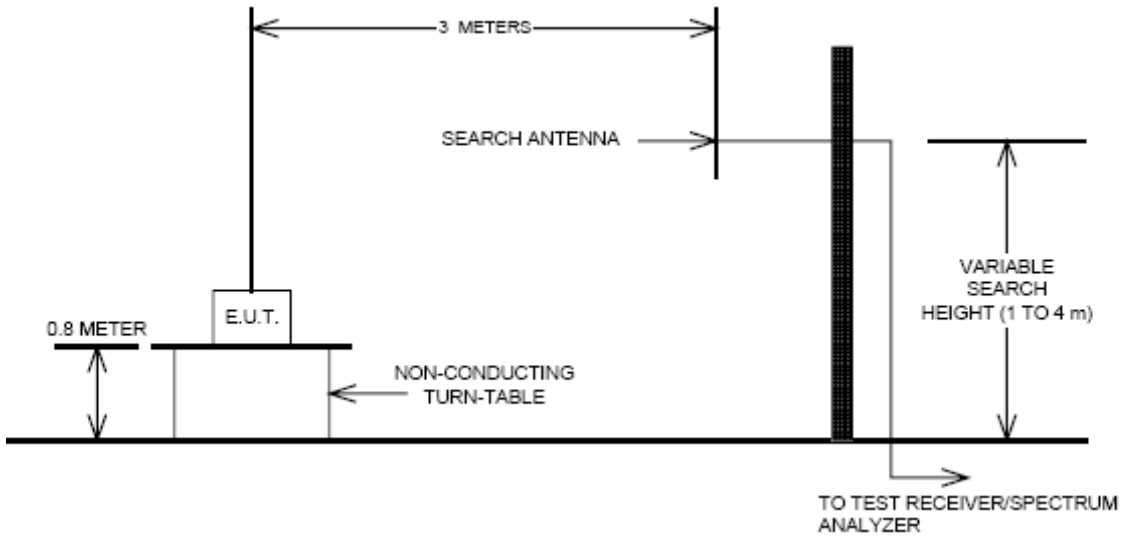

The measurement facilities used for this test have been documented in previous filings with the commission pursuant to section § 2.948. The SAC(Semi-Anechoic Chamber) meets requirements in ANSI C63.4 –2003. A mast capable of lifting the receiving antenna from a height of one to four meters is used together with a rotatable styrofoam platform mounted at three from the antenna mast.

- 1) The unit mounted on a styrofoam turntable 1.5 m × 1.0 m × 0.80 m is 0.8 meter above test site ground level.
- 2) During the emission test, the turntable is rotated and the EUT is manipulated to find the configuration resulting in maximum emission under normal condition of installation and operation.
- 3) The antenna height and polarization are also varied from 1 to 4 meters until the maximum signal is found.
- 4) The spectrum shall be scanned up to the 10th harmonic of the fundamental frequency.

Test Procedure

The equipment under test is placed on a non-conductive styrofoam resin table 3-meters from the receive antenna. A styrofoam turntable was rotated 360° and the receiving antenna scanned from 1-4m in order to capture the maximum emission. A half wave dipole was substituted in place of the EUT. This dipole antenna was driven by a signal generator and the previously recorded signal was duplicated.

The maximum EIRP was calculated by adding the forward power to the calibrated source plus its appropriate gain value. These steps were carried out with the receiving antenna in both vertical and horizontal polarization. For readings above 1GHz, the above procedure is repeated using horn antennas and the difference between the gain of the horn and an isotropic antenna are taken into consideration.

FCC CERTIFICATION REPORT			www.hct.co.kr
Test Report No. HCTR1201FR28-1	Date of Issue: February 01, 2012	EUT Type: PCS WCDMA Modem	FCC ID: ZNFUD711

3.6 FREQUENCY STABILITY / VARIATION OF AMBIENT TEMPERATURE

Test Set-up

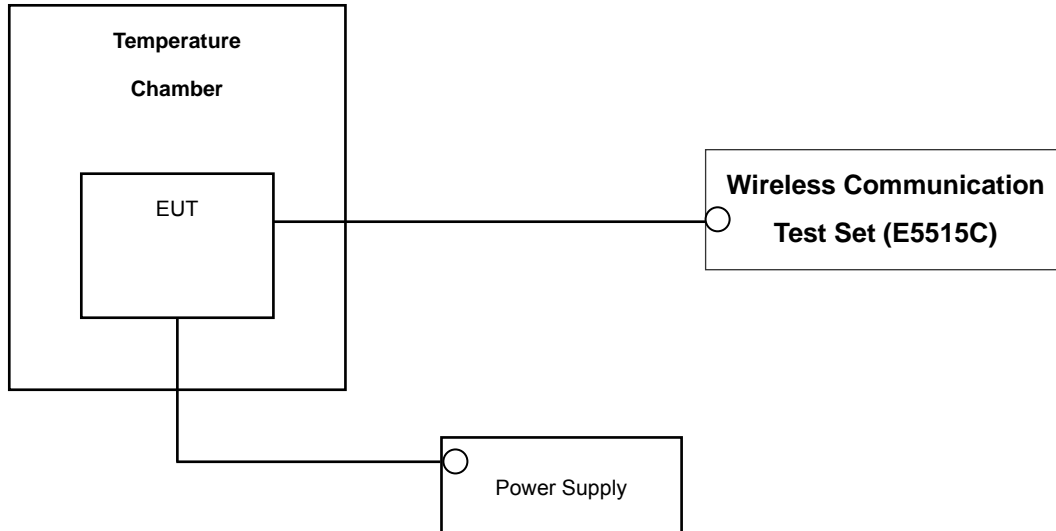

* Nominal Operating Voltage

Test Procedure

The frequency stability of the transmitter is measured by:

- a.) **Temperature:** The temperature is varied from - 30 °C to + 50 °C using an environmental chamber.
- b.) **Primary Supply Voltage:** The primary supply voltage is varied from battery end point to 115 % of the voltage normally at the input to the device or at the power supply terminals if cables are not normally supplied.

Specification — the frequency stability shall be sufficient to ensure that the fundamental emission stays within the authorized frequency block. The frequency stability of the transmitter shall be maintained within $\pm 0.00025\%$ (± 2.5 ppm) of the center frequency.

Time Period and Procedure:

The carrier frequency of the transmitter is measured at room temperature (20°C to provide a reference).

1. The equipment is turned on in a “standby” condition for one minute before applying power to the transmitter. Measurement of the carrier frequency of the transmitter is made within one minute after applying power to the transmitter.
2. Frequency measurements are made at 10°C intervals ranging from -30°C to +50°C. A period of at least one half-hour is provided to allow stabilization of the equipment at each temperature level.

NOTE: The EUT is tested down to the battery endpoint.

FCC CERTIFICATION REPORT			www.hct.co.kr
Test Report No. HCTR1201FR28-1	Date of Issue: February 01, 2012	EUT Type: PCS WCDMA Modem	FCC ID: ZNFUD711

4. LIST OF TEST EQUIPMENT

Manufacture	Model/ Equipment	Serial Number	Calibration Interval	Calibration Due
R&S	N9020A	MY51110020	Annual	09/23/2012
Agilent	E9327A/ Power Sensor	MY4442009	Annual	05/02/2012
R&S	CMW500/ Base Station	1201.0002K50_10395	Annual	04/20/2012
MITEQ	AMF-6D-001180-35-20P/AMP	1081666	Annual	09/24/2012
Wainwright	WHK1.2/15G-10EF/H.P.F	2	Annual	05/02/2012
Wainwright	WHK3.3/18G-10EF/H.P.F	1	Annual	05/02/2012
Agilent	11636B/ Power Divider	11377	Annual	11/07/2012
Digital	EP-3010/ Power Supply	3110117	Annual	11/07/2012
Schwarzbeck	UHAP/ Dipole Antenna	557	Biennial	05/03/2012
Schwarzbeck	UHAP/ Dipole Antenna	558	Biennial	05/03/2012
Korea Engineering	KR-1005L / Chamber	KRAB05063-3CH	Annual	11/07/2012
Schwarzbeck	BBHA 9120D/ Horn Antenna	147	Biennial	04/13/2012
Agilent	E4440A/Spectrum Analyzer	US45303008	Annual	05/02/2012
WEINSCHL	ATTENUATOR	BR0592	Annual	11/07/2012
REOHDE&SCHWARZ	FSP30/Spectrum Analyzer	839117/011	Annual	03/23/2012
Agilent	8960 (E5515C)/ Base Station	GB44400269	Annual	02/10/2012

5. SUMMARY OF TEST RESULTS

FCC Part Section(s)	Test Description	Test Limit	Test Condition	Test Result
2.1049, 24.238(a)	Occupied Bandwidth	N/A	CONDUCTED	PASS
2.1051, 24.238(a)	Band Edge / Spurious and Harmonic Emissions at Antenna Terminal.	< 43 + 10log ₁₀ (P[Watts]) at Band Edge and for all out-of-band emissions		PASS
2.1046	Conducted Output Power	N/A		PASS
24.232(d)	Peak- to- Average Ratio	< 13 dB		PASS
2.1055, 24.235	Frequency stability / variation of ambient temperature	< 2.5 ppm		PASS
24.232(c)	Equivalent Isotropic Radiated Power	< 2 Watts max. EIRP	RADIATED	PASS
2.1053, 24.238(a)	Radiated Spurious and Harmonic Emissions	< 43 + 10log ₁₀ (P[Watts]) for all out-of band emissions		PASS

6. SAMPLE CALCULATION

A. EIRP Sample Calculation

Mode	Ch./ Freq.		Measured Level(dBm)	Substitute LEVEL(dBm)	Ant. Gain	C.L	Pol.	EIRP	
	channel	Freq.(MHz)						W	dBm
WCDMA	9400	1,880.00	-17.51	16.27	10.43	2.81	H	0.245	23.89

EIRP = SubstituteLEVEL(dBm) + Ant. Gain – CL(Cable Loss)

- 1) The EUT mounted on a wooden tripod is 0.8 meter above test site ground level.
- 2) During the test , the turn table is rotated and the antenna height is also varied from 1 to 4 meters until the maximum signal is found.
- 3) Record the field strength meter's level.
- 4) Replace the EUT with dipole/Horn antenna that is connected to a calibrated signal generator.
- 5) Increase the signal generator output till the field strength meter's level is equal to the item (3).
- 6) The signal generator output level with Ant. Gain and cable loss are the rating of effective radiated power (EIRP).

B. Emission Designator

GSM Emission Designator

Emission Designator = 249KGXW

GSM BW = 249 kHz

G = Phase Modulation

X = Cases not otherwise covered

W = Combination (Audio/Data)

WCDMA Emission Designator

Emission Designator = 4M17F9W

WCDMA BW = 4.17 MHz

F = Frequency Modulation

9 = Composite Digital Info

W = Combination (Audio/Data)

FCC CERTIFICATION REPORT			www.hct.co.kr
Test Report No. HCTR1201FR28-1	Date of Issue: February 01, 2012	EUT Type: PCS WCDMA Modem	FCC ID: ZNFUD711

7. TEST DATA

7.1 CONDUCTED OUTPUT POWER

A base station simulator was used to establish communication with the EUT. The base station simulator parameters were set to produce the maximum power from the EUT. This device was tested under all configurations and the highest power is reported. Conducted Output Powers of EUT are reported below.

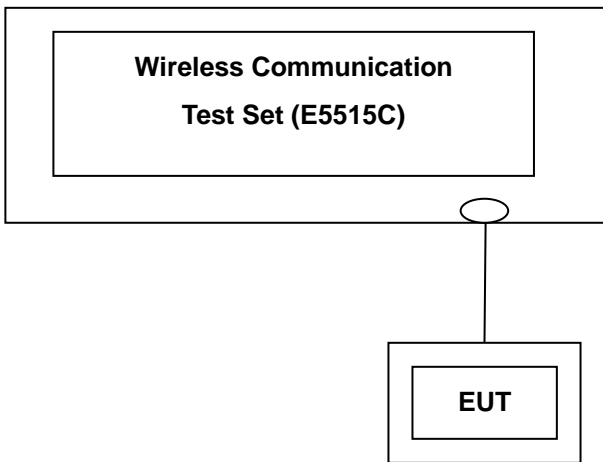

FCC CERTIFICATION REPORT			www.hct.co.kr
Test Report No. HCTR1201FR28-1	Date of Issue: February 01, 2012	EUT Type: PCS WCDMA Modem	FCC ID: ZNFUD711

Test Result

3GPP Release Version	Mode	3GPP 34.121	PCS Band [dBm]			MPR
		Subtest	UL 9262 (1852.4)	UL 9400 (1880.0)	UL 9538 (1907.6)	
			DL 9662	DL 9800	DL 9938	
99	WCDMA	12.2 kbps RMC	22.62	22.50	22.54	-
99	WCDMA	12.2 kbps AMR	22.58	22.49	22.51	-
5	HSDPA	Subtest 1	22.60	22.48	22.53	0
5		Subtest 2	22.61	22.51	22.53	0
5		Subtest 3	22.15	22.05	22.01	-0.5
5		Subtest 4	22.17	22.04	22.02	-0.5
6	HSUPA	Subtest 1	22.64	22.35	22.24	0
6		Subtest 2	21.14	20.89	21.09	-2
6		Subtest 3	21.61	21.20	21.23	-1
6		Subtest 4	21.72	21.28	21.35	-2
6		Subtest 5	22.53	22.13	22.41	0

(WCDMA Conducted Output Powers)

Note : Detecting mode is average.

7.2 PEAK-TO-AVERAGE RATIO

- Plots of the EUT's Peak- to- Average Ratio are shown Page 23.

7.3 OCCUPIED BANDWIDTH

Band	Channel	Frequency(MHz)	Data (MHz)
WCDMA1900	9262	1852.40	4.1762
	9400	1880.00	4.1391
	9538	1907.60	4.1466

- Plots of the EUT's Occupied Bandwidth are shown Page 22 ~ 23.

7.4 CONDUCTED SPURIOUS EMISSIONS

Band	Channel	Frequency of Maximum Harmonic (GHz)	Maximum Data (dBm)
WCDMA1900	9262	14.2100	-38.12
	9400	14.0500	-39.51
	9538	3.8150	-39.69

- Plots of the EUT's Conducted Spurious Emissions are shown Page 26 ~ 28.

7.4.1 BAND EDGE

- Plots of the EUT's Band Edge are shown Page 24 ~ 25.

7.5 EQUIVALENT ISOTROPIC RADIATED POWER

(WCDMA1900 Mode)

Ch./ Freq.		Measured Level(dBm)	Substitute LEVEL (dBm)	Ant. Gain (dBi)	C.L	Pol.	EIRP	
channel	Freq.(MHz)						W	dBm
9262	1,852.40	-18.25	15.46	10.40	2.83	H	0.200	23.02
9400	1,880.00	-17.51	16.27	10.43	2.81	H	0.245	23.89
9538	1,907.60	-17.82	16.17	10.47	2.86	H	0.239	23.78

Note: Standard batteries are the only options for this phone

NOTES:

Equivalent Isotropic Radiated Power Measurements by Substitution Method

according to ANSI/TIA/EIA-603-C-2004, Aug. 17, 2004:

The EUT was placed on a non-conductive styrofoam resin table 3-meters from the receive antenna. The receive antenna height and turntable rotation was adjusted for the highest reading on the receive spectrum analyzer. For CDMA signals, a peak detector is used, with RBW = VBW = 3 MHz. For WCDMA signals, a peak detector is used, with RBW = VBW = 5MHz. For AMPS, GSM, and NADC TDMA signals, a peak detector is used, with RBW = VBW = 1 MHz. A Horn antenna was substituted in place of the EUT. This Horn antenna was driven by a signal generator and the level of the signal generator was adjusted to obtain the same receive spectrum analyzer reading. The conducted power at the terminals of the Horn antenna is measured. The difference between the gain of the horn and an isotropic antenna is taken into consideration and the EIRP is recorded.

This device was tested under all configurations and the highest power is reported in WCDMA mode with HSDPA Inactive at 12.2 kbps RMC and TPC bits all set to "1" and in GSM mode and using a Power Control Level of "0" in the PCS Band and "5" in the Cellular Band. This unit was tested with its standard battery. Also, we have done x, y, z planes in EUT and horizontal and vertical polarization in detecting antenna. The worst case of the EUT is x plane in WCDMA1900 mode. Also worst case of detecting Antenna is in horizontal polarization in WCDMA1900 mode.

FCC CERTIFICATION REPORT			www.hct.co.kr
Test Report No. HCTR1201FR28-1	Date of Issue: February 01, 2012	EUT Type: PCS WCDMA Modem	FCC ID: ZNFUD711

7.6 RADIATED SPURIOUS EMISSIONS

7.6.1 RADIATED SPURIOUS EMISSIONS (WCDMA1900)

- MEASURED OUTPUT POWER: 23.89 dBm = 0.245 W
- MODULATION SIGNAL: WCDMA1900
- DISTANCE: 3 meters
- LIMIT: $-(43 + 10 \log_{10}(W)) =$ - 36.89 dBc

Ch.	Freq.(MHz)	Measured Level [dBm]	Ant. Gain (dBi)	Substitute Level [dBm]	C.L	Pol.	EIRP (dBm)	dBc
9262	3,704.80	-49.25	12.36	-51.04	4.87	V	-43.55	-67.44
	5,557.20	-	-	-	-	-	-	-
	7,409.60	-	-	-	-	-	-	-
9400	3,760.00	-51.38	12.40	-53.10	4.88	V	-45.58	-69.47
	5,640.00	-	-	-	-	-	-	-
	7,520.00	-	-	-	-	-	-	-
9538	3,815.20	-52.16	12.44	-54.40	5.00	V	-46.96	-70.85
	5,722.80	-	-	-	-	-	-	-
	7,630.40	-	-	-	-	-	-	-

- NOTES:**
1. Radiated Spurious Emission Measurements at 3 meters by Substitution Method according to ANSI/TIA/EIA-603-C-2004, Aug. 17, 2004:
 2. The magnitude of spurious emissions attenuated more than 20dB below the limit above 5th Harmonic for all channel.
 3. we have done x, y, z planes in EUT and horizontal and vertical polarization in detecting antenna.

FCC CERTIFICATION REPORT			www.hct.co.kr
Test Report No. HCTR1201FR28-1	Date of Issue: February 01, 2012	EUT Type: PCS WCDMA Modem	FCC ID: ZNFUD711

7.7 FREQUENCY STABILITY / VARIATION OF AMBIENT TEMPERATURE

7.7.1 FREQUENCY STABILITY (WCDMA1900)

OPERATING FREQUENCY: 1,880,000,000 Hz
 CHANNEL: 9400
 REFERENCE VOLTAGE: 3.7 VDC
 DEVIATION LIM IT: ± 0.000 25 % or 2.5 ppm

Voltage (%)	Power (VDC)	Temp. (°C)	Frequency (Hz)	Frequency Error (Hz)	Deviation (%)	ppm
100%	3.700	+20(Ref)	1879 999 992	0	0.000 000	0.000
100%		-30	1880 000 008	8.34	0.000 000	0.004
100%		-20	1880 000 006	5.90	0.000 000	0.003
100%		-10	1880 000 007	6.56	0.000 000	0.003
100%		0	1880 000 007	6.83	0.000 000	0.004
100%		+10	1880 000 009	8.50	0.000 000	0.005
100%		+30	1880 000 007	7.17	0.000 000	0.004
100%		+40	1880 000 008	7.70	0.000 000	0.004
100%		+50	1880 000 007	6.89	0.000 000	0.004
115%	4.255	+20	1880 000 008	8.36	0.000 000	0.004
Batt. Endpoint	3.400	+20	1880 000 007	7.11	0.000 000	0.004

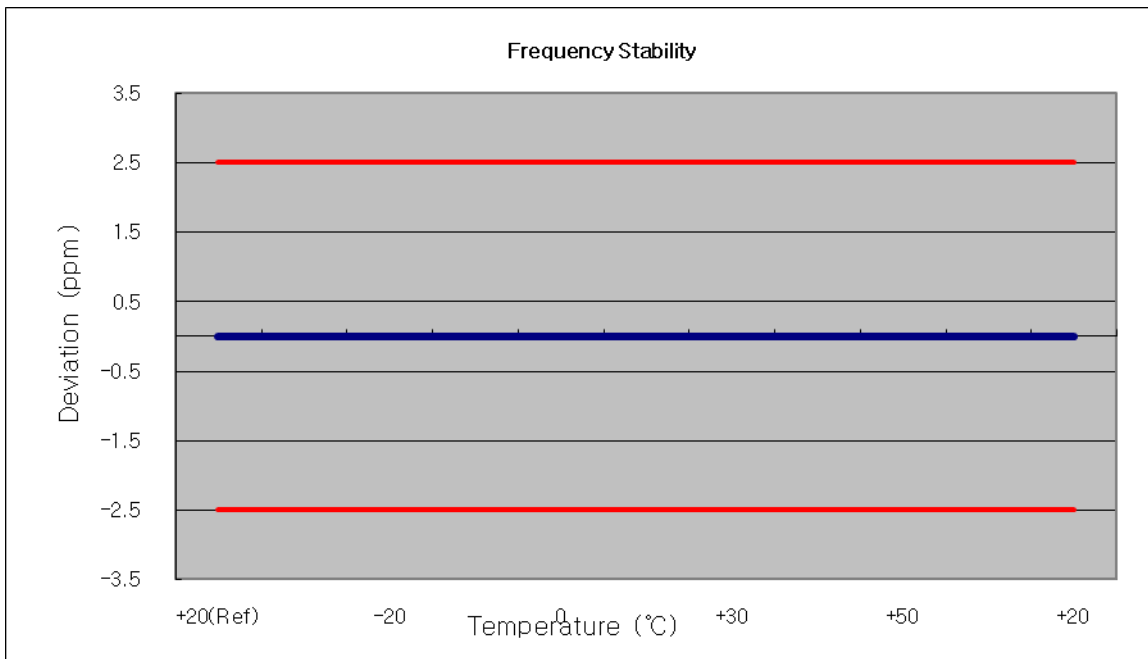



8. TEST PLOTS

FCC CERTIFICATION REPORT			www.hct.co.kr
Test Report No. HCTR1201FR28-1	Date of Issue: February 01, 2012	EUT Type: PCS WCDMA Modem	FCC ID: ZNFUD711

■ WCDMA1900 MODE (9262 CH.) Occupied Bandwidth

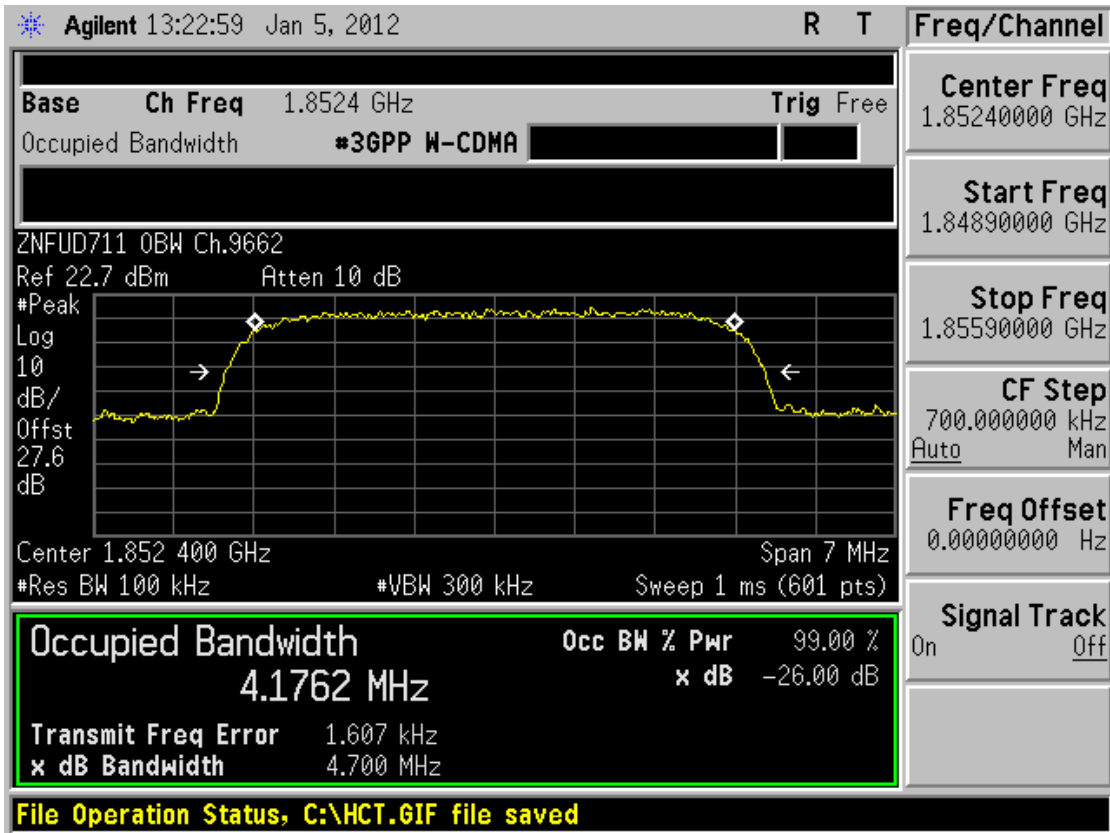

■ WCDMA1900 MODE (9400 CH.) Occupied Bandwidth

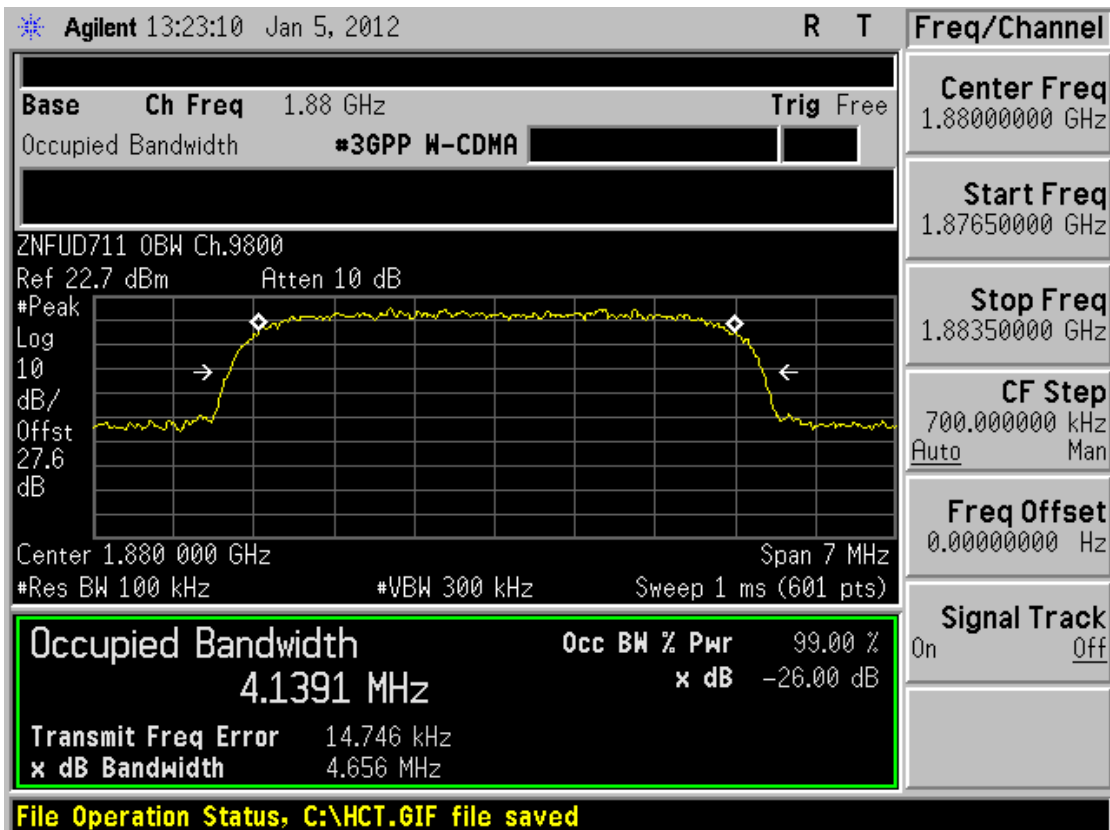

■ WCDMA1900 MODE (9538 CH.) Occupied Bandwidth

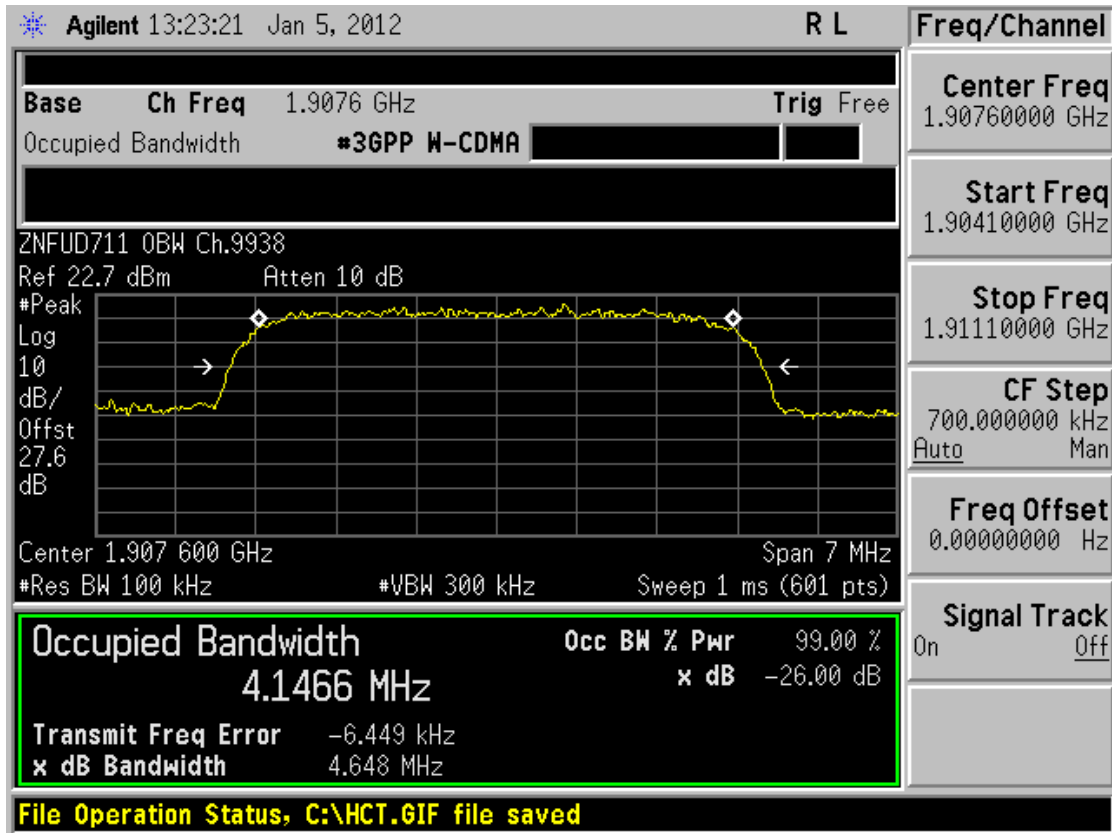

■ WCDMA1900 MODE (9400 CH.) Peak-to-Average Ratio

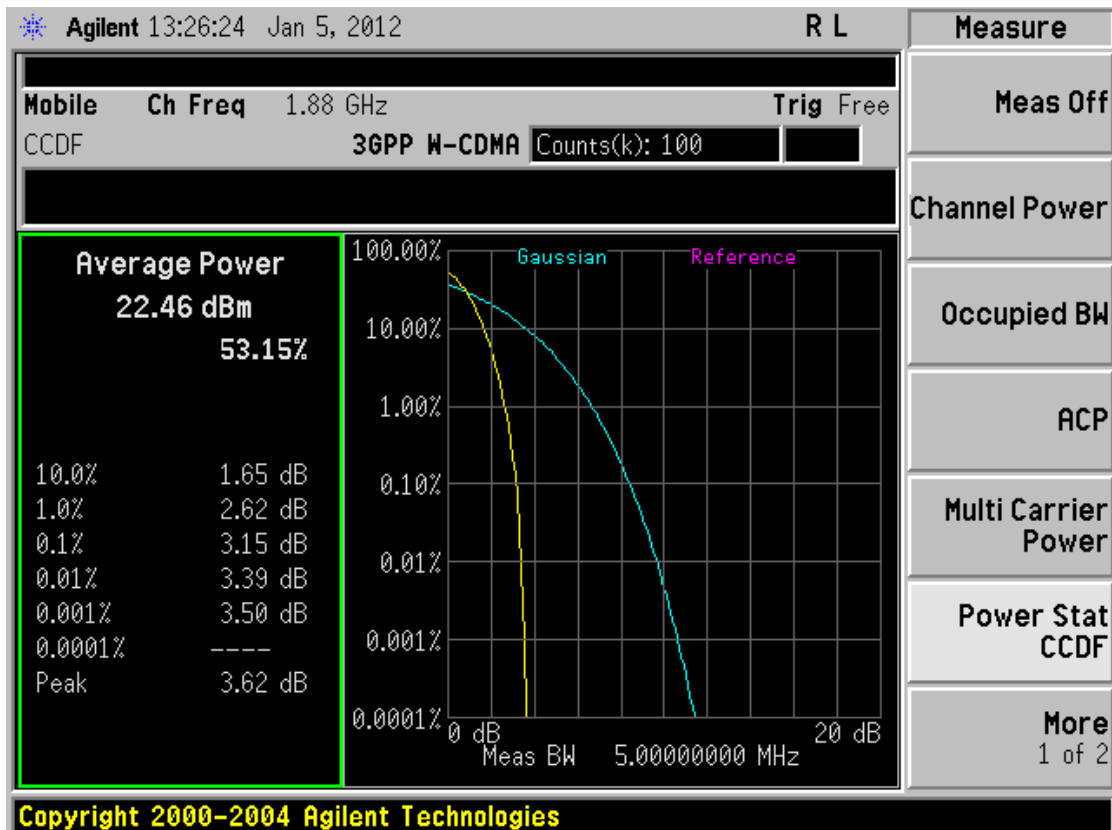

■ WCDMA1900 MODE (9262 CH.) Block Edge

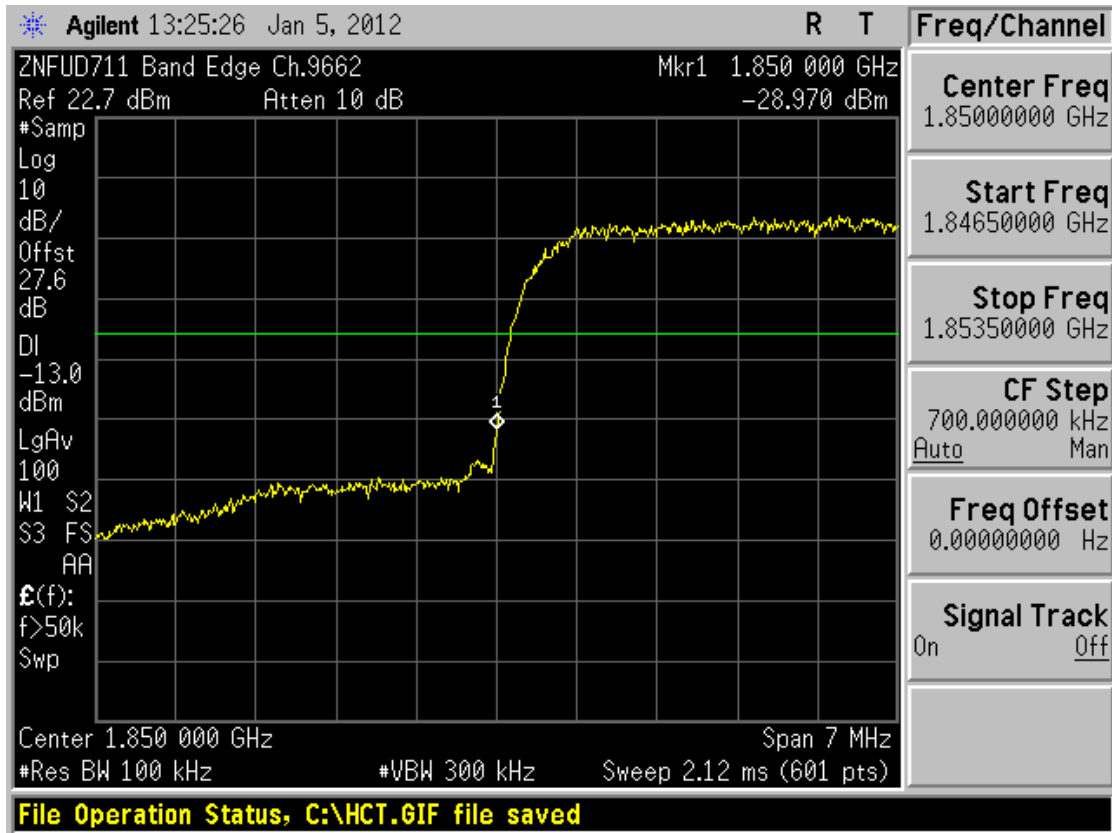

■ WCDMA1900 MODE (9538 CH.) Block Edge

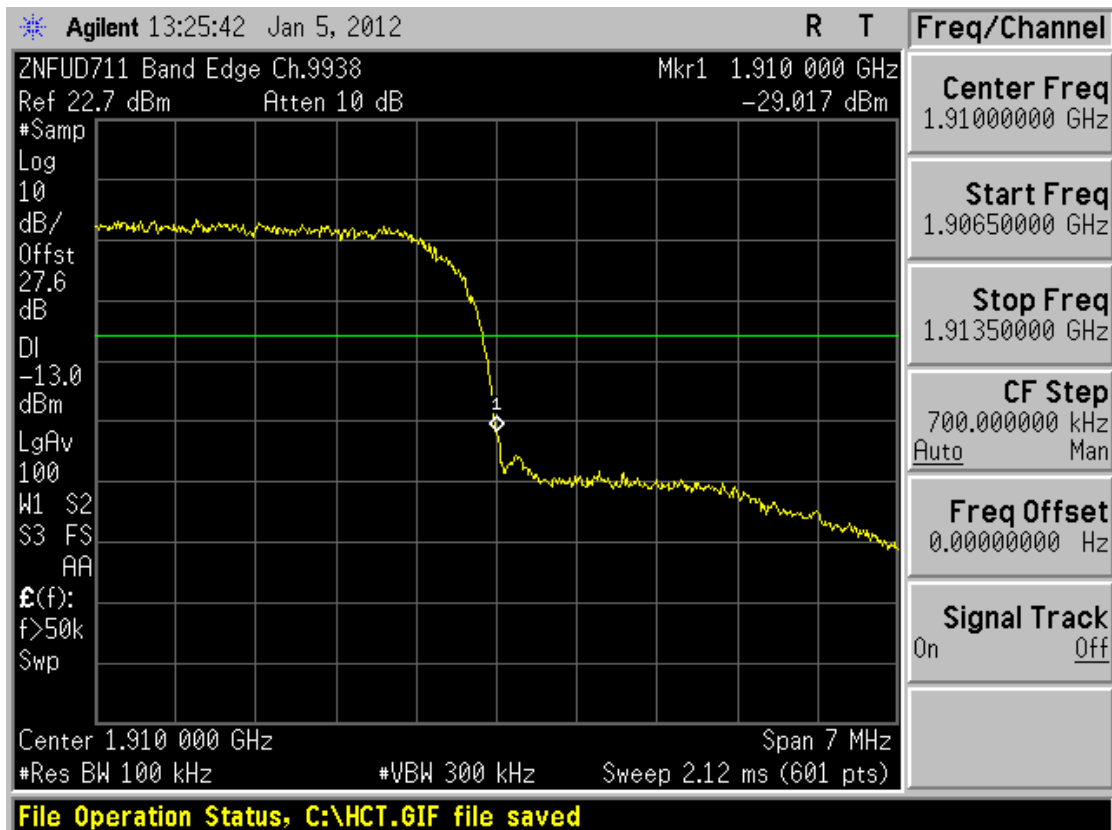

■ WCDMA1900 MODE (9262 CH.) – 4 MHz Span

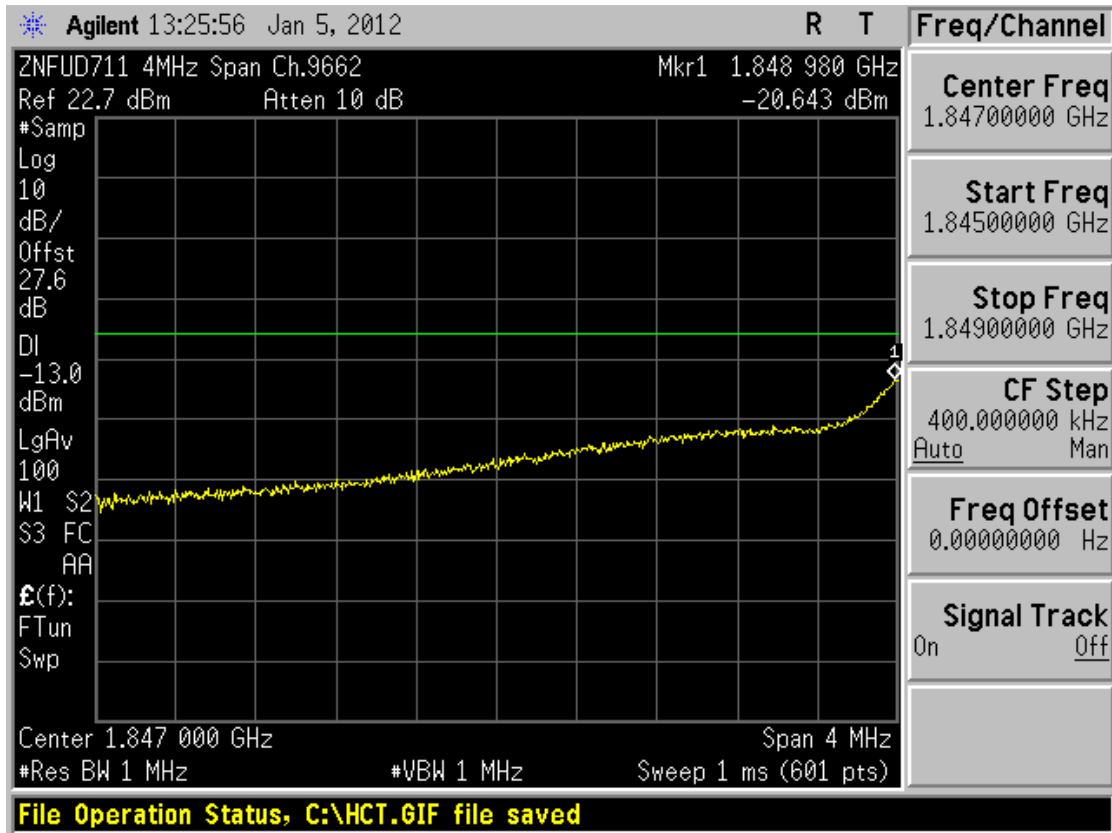

■ WCDMA1900 MODE (9538 CH.) – 4 MHz Span

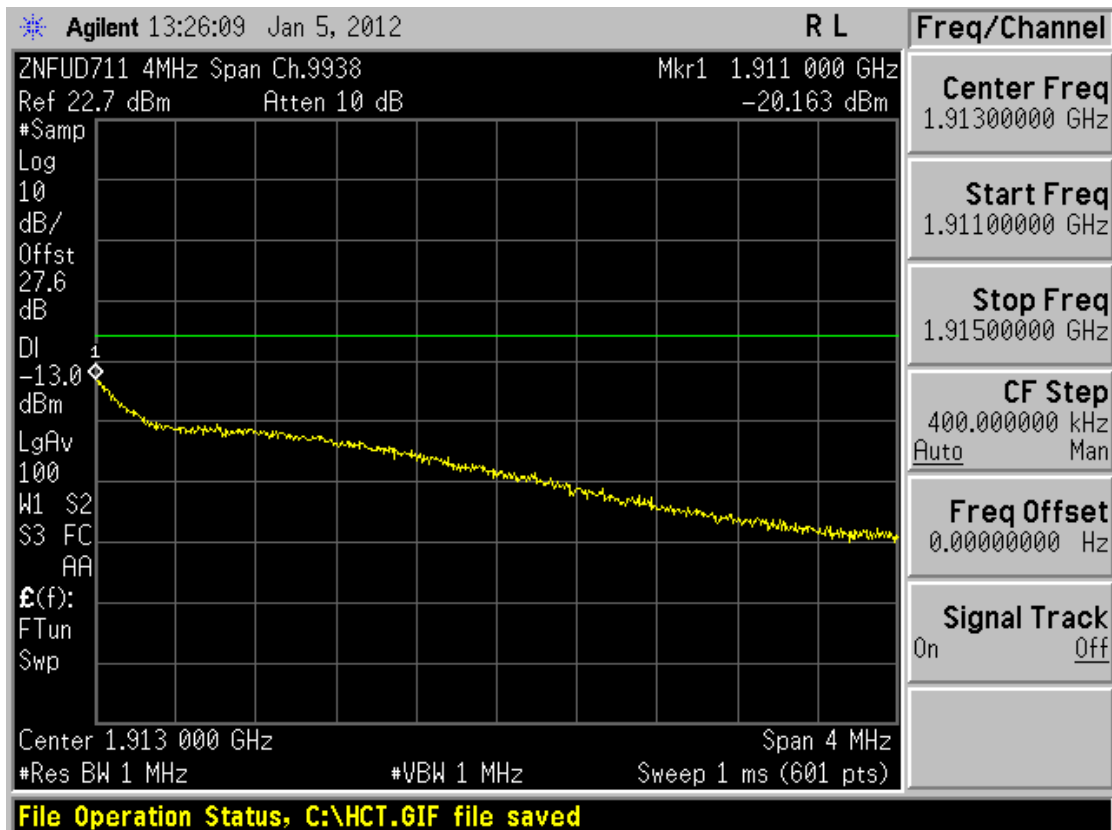

■ WCDMA1900 MODE (9262 CH.) Conducted Spurious Emissions1

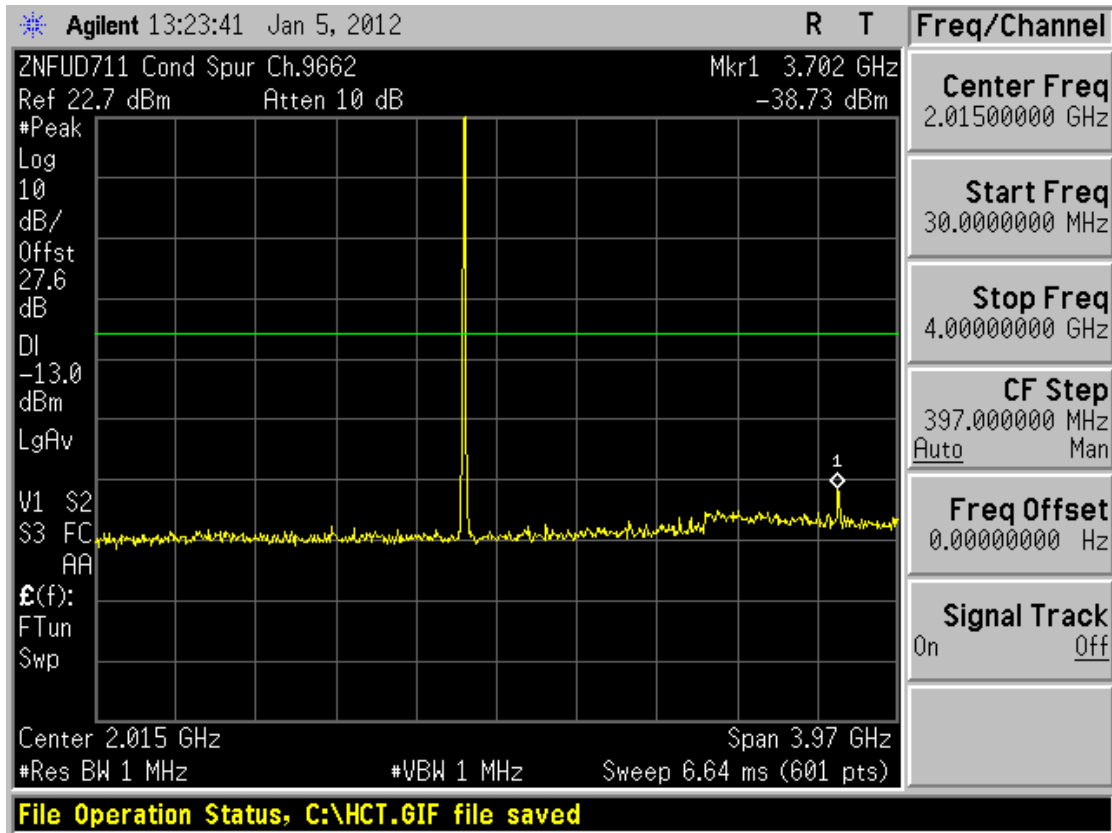

■ WCDMA1900 MODE (9262 CH.) Conducted Spurious Emissions2

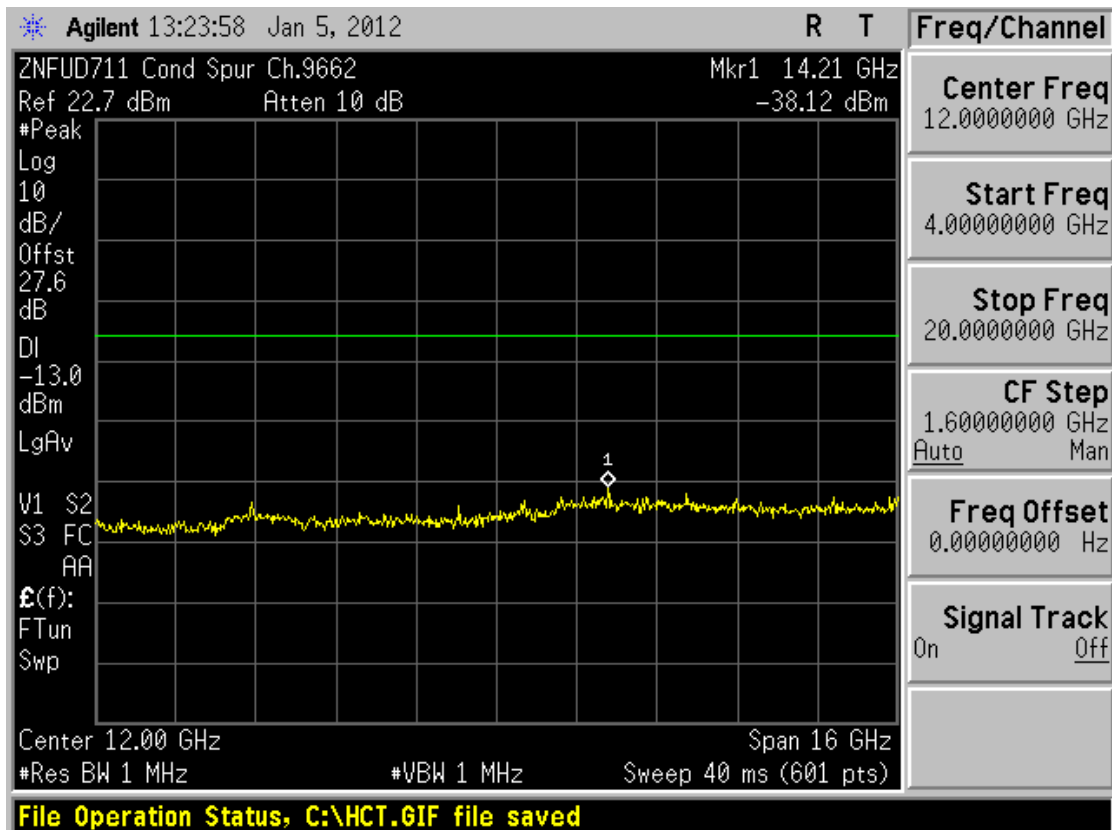

■ WCDMA1900 MODE (9400 CH.) Conducted Spurious Emissions1

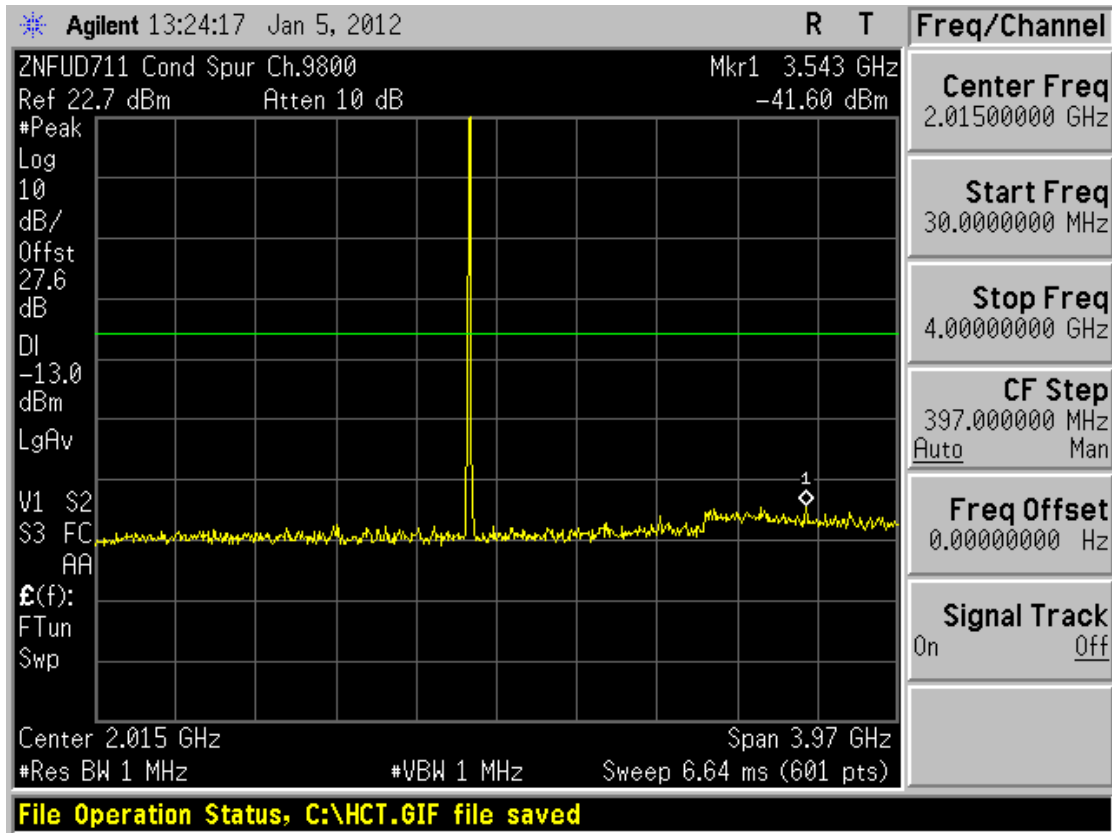

■ WCDMA1900 MODE (9400 CH.) Conducted Spurious Emissions2

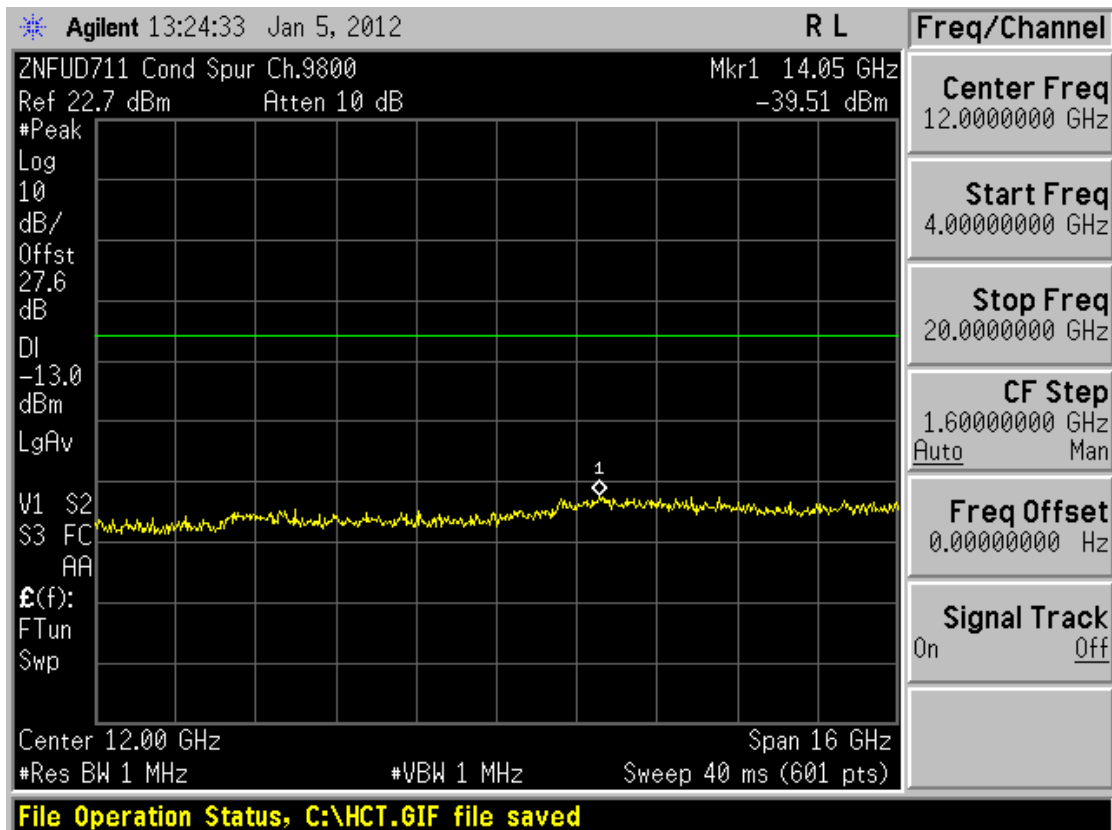

■ WCDMA1900 MODE (9538 CH.) Conducted Spurious Emissions1

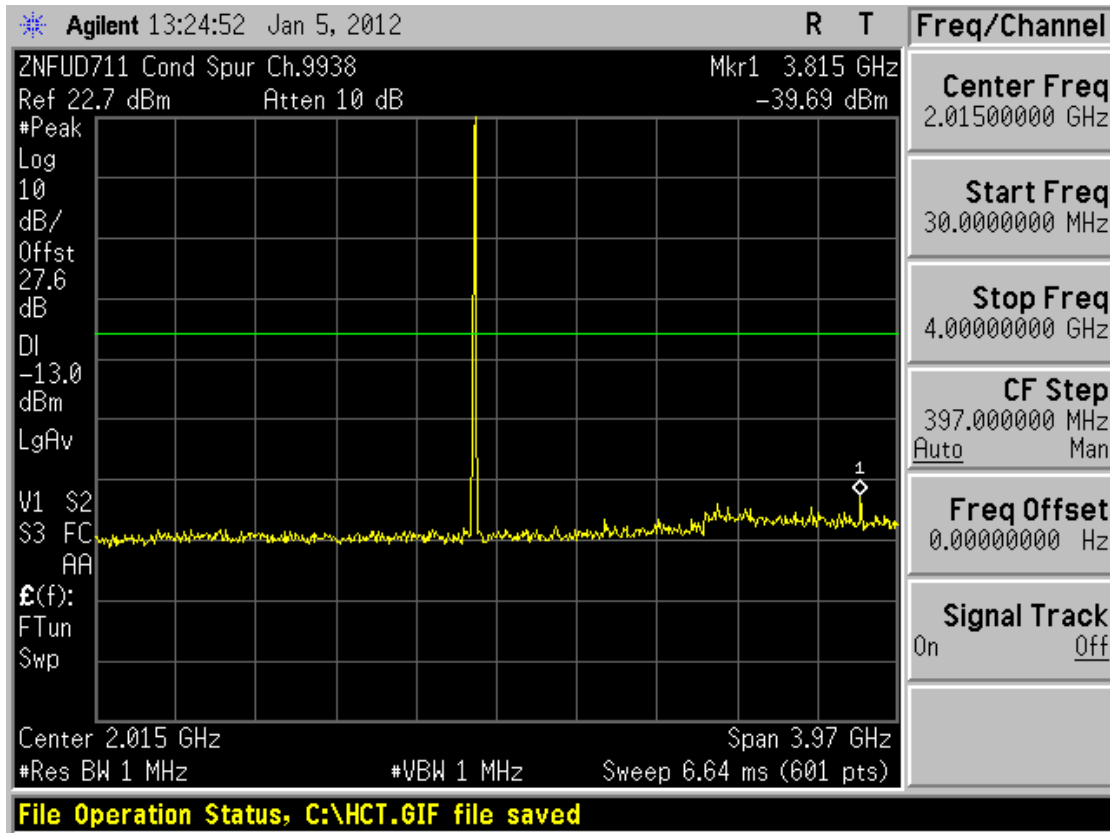

■ WCDMA1900 MODE (9538 CH.) Conducted Spurious Emissions2

