

On your side

HCT

TEST REPORT

EMI Test for FCC Certification of LM-T600US Model

APPLICANT

LG Electronics USA, Inc.

REPORT NO.

HCT-EM-1907-FC015-R1

DATE OF ISSUE

August 30, 2019

HCT Co., Ltd.

74, Seoicheon-ro 578beon-gil, Majang-myeon, Icheon-si, Gyeonggi-do, 17383 KOREA

Tel. +82 31 645 6300 Fax. +82 31 645 6401



HCT Co., Ltd.

74, Seoicheon-ro 578beon-gil, Majang-myeon, Icheon-si, Gyeonggi-do, 17383 KOREA
Tel. +82 31 645 6300 Fax. +82 31 645 6401

**TEST
REPORT**
EMI Test for
FCC Certification

REPORT NO.
HCT-EM-1907-FC015-R1

DATE OF ISSUE
August 30, 2019

FCC ID.
ZNFT600US

Applicant **LG Electronics USA, Inc.**
1000 Sylvan Avenue, Englewood Cliffs NJ 07632 United States

Product Name Multi-band WCDMA/LTE Tablet with BT and WiFi
Model Name LM-T600US
Series Model Name LMT600US, T600US, LM-T600QS, LMT600QS, T600QS

Date of Test July 16, 2019 to July 23, 2019

Test Standard Used FCC CFR 47 PART 15 Subpart B Class B
ANSI C63.4-2014

Test Results Refer to the present document

Manufacturer LG Electronics Inc.

The result shown in this test report refer only to the sample(s) tested unless otherwise stated.

Tested by
Na-Eun Song



(signature)

Technical Manager
Jeong-I Iyun Choi



(signature)

This report only responds to the tested sample and may not be reproduced, except in full, without written approval of the HCT Co., Ltd.

REVISION HISTORY

The revision history for this test report is shown in table.

Revision No.	Date of Issue	Description
0	July 26, 2019	Initial Release
1	August 30, 2019	Revised the Tx and Rx Frequency lists

The device bearing the trade name and model specified above, has been shown to comply with the applicable technical standards as indicated in the measurement report and was tested in accordance with the measurement procedures specified in ANSI C63.4-2014. (See Test Report if any modifications were made for compliance)

I attest to the accuracy of data. All measurements reported herein were performed by me or were made under my supervision and are correct to the best of my knowledge and belief. I assume full responsibility for the completeness of these measurements and vouch for the qualifications of all persons taking them.

HCT certifies that no party to application has been denied the FCC benefits pursuant to Section 5301 of the Anti-Drug Abuse Act of 1988, 21 U.S.C 862

CONTENTS

1. GENERAL INFORMATION	5
1.1 Description of EUT	5
1.2 Tested System Details	6
1.3 Cable Description	7
1.4 Noise Suppression Parts on Cable. (I/O Cable)	7
1.5 Test Facility	8
1.6 Calibration of Measuring Instrument	8
1.7 Measurement Uncertainty	8
2. DESCRIPTION OF TEST	9
2.1 Measurement of Conducted Emission	9
2.2 Measurement of Radiated Emission	10
2.3 Configuration of Tested System	11
3. PRELIMINARY TEST	12
3.1 Conducted Emission	12
3.2 Radiated Emission	12
4. EMISSION TEST SUMMARY	13
4.1 Conducted Emission	13
4.2 Radiated Emission Below 1 GHz	20
4.3 Radiated Emission Above 1 GHz	22
5. CONCLUSION	25
6. APPENDIX A. TEST SETUP PHOTOGRAPHS	26

1. GENERAL INFORMATION

1.1 Description of EUT

The EUT is mobile phone.

FCC ID	ZNFT600US
Model Name	LM-T600US
Series Model Name	LMT600US, T600US, LM-T600QS, LMT600QS, T600QS
Product Name	Multi-band WCDMA/LTE Tablet with BT and WiFi
TX Frequency	1 852.4 MHz to 1 907.6 MHz (WCDMA B2) 1712.4 MHz to 1752.6 MHz (WCDMA B4) 826.40 MHz to 846.60 MHz (WCDMA B5) 1 850 MHz to 1 910 MHz (LTE B2) 1 710 MHz to 1 755 MHz (LTE B4) 824 MHz to 849 MHz (LTE B5) 2500 MHz to 2570 MHz (LTE B7) 699 MHz to 716 MHz (LTE B12) 777 MHz to 787 MHz (LTE B13) 1 850 MHz to 1 915 MHz (LTE B25) 814 MHz to 849 MHz (LTE B26) 2496 MHz to 2690 MHz (LTE B41) 1 710 MHz to 1 780 MHz (LTE B66) 663 MHz to 698 MHz (LTE B71) 2 402 MHz to 2 480 MHz (Bluetooth) 2 412 MHz to 2 462 MHz (WiFi 2.4 GHz) 5 180 MHz to 5 240 MHz (WiFi 5 GHz_UNII 1) 5 260 MHz to 5 320 MHz (WiFi 5 GHz_UNII 2A) 5 500 MHz to 5 720 MHz (WiFi 5 GHz_UNII 2C) 5 745 MHz to 5 825 MHz (WiFi 5 GHz_UNII 3)
RX Frequency	1 932.4 MHz to 1 987.6 MHz (WCDMA B2) 2 112.4 MHz to 2 152.6 MHz (WCDMA B4) 871.40 MHz to 891.60 MHz (WCDMA B5) 1 930 MHz to 1 990 MHz (LTE B2) 2 110 MHz to 2 155 MHz (LTE B4) 869 MHz to 894 MHz (LTE B5) 2620 MHz to 2690 MHz (LTE B7) 729 MHz to 746 MHz (LTE B12)

This report only responds to the tested sample and may not be reproduced, except in full, without written approval of the HCT Co., Ltd.

	746 MHz to 756 MHz (LTE B13) 1 925 MHz to 1 990 MHz (LTE B25) 859 MHz to 894 MHz (LTE B26) 2496 MHz to 2690 MHz (LTE B41) 2 110 MHz to 2 200 MHz (LTE B66) 617 MHz to 652 MHz (LTE B71) 2 402 MHz to 2 480 MHz (Bluetooth) 2 412 MHz to 2 462 MHz (WiFi 2.4 GHz) 5 180 MHz to 5 240 MHz (WiFi 5 GHz_UNII 1) 5 260 MHz to 5 320 MHz (WiFi 5 GHz_UNII 2A) 5 500 MHz to 5 720 MHz (WiFi 5 GHz_UNII 2C) 5 745 MHz to 5 825 MHz (WiFi 5 GHz_UNII 3)
--	---

1.2 Tested System Details

All equipment descriptions used in the tested system (including inserted cards) are:

Device Type	Model Name	Serial Number	Manufacturer
EUT	LM-T600US	-	LG
Data Cable	EAD64746101	-	Ningbo
Data Cable	EAD64746102	-	Luxshare
Earphone	EAB64468444	-	CRESYN
Notebook PC	ProBook6560b	5CB2053MXF	HP
Notebook PC Adaptor	Series PPP009L-E	-	LITE-ON TECHNOLOGY (CHANGZHOU) CO.LTD
Gateway	DIR-806M	-	D-Link
Gateway Adaptor	AMS1-0501200FK	-	D-Link
Serial Mouse	Serial 2 Button mouse	02031069	Radio Shack
RJ45 cable	-	-	-
Micro SD Card	SAMSUNG EVO+ microSDXC CLASS10 UHS- I (256 GB)	-	SAMSUNG

This report only responds to the tested sample and may not be reproduced, except in full, without written approval of the HCT Co., Ltd.

1.3 Cable Description

Product Name	Port	Power Cord Shielded (Y/N)	I/O Cable Shielded (Y/N)	Length (m)
EUT	USB C type	Y	Y	(P,D) 1.0
	Earphone	N/A	N	(D) 1.2
Notebook PC	RJ 45	N/A	N	(D) 1.6
	Serial(Mouse)	N/A	Y	(D) 1.8
	DC IN	N	N/A	(P) 1.8
Gateway	DC IN	N	N/A	(P) 1.8

NOTE. The marked "(D)" means the data cable and "(P)" means the power cable.

1.4 Noise Suppression Parts on Cable (I/O Cable)

Product Name	Port	Ferrite Bead (Y/N)	Location	Metal Hood (Y/N)	Location
EUT	USB C type	N	N/A	Y	Both End
	Earphone	N	N/A	Y	EUT End
Notebook PC	RJ 45	N	N/A	N	N/A
	Serial(Mouse)	N	N/A	Y	Notebook PC End

1.5 Test Facility

Test site is located at 74, Seoicheon-ro 578beon-gil, Majang-myeon, Icheon-si, Gyeonggi-do, South Korea. Those measurement facilities are constructed in conformance with the requirements of ANSI C63.4-2014. The Normalized site attenuations (30 MHz to 1 GHz) and Site validation (1 GHz to 18 GHz) were performed in accordance with the standard in ANSI C63.4-2014

Measurement Facilities	Designation No.
Radiated Field strength measurement facility 3 m Semi Anechoic chamber	KR0032
Radiated Field strength measurement facility 10 m Semi Anechoic chamber #1	
Radiated Field strength measurement facility 10 m Semi Anechoic chamber #2	

1.6 Calibration of Measuring Instrument

The measuring equipment, which was utilized in performing the tests documented herein, has been calibrated in accordance with the manufacturers recommendations for utilizing calibration equipment, which is traceable to recognized national standards. Especially, all antenna for measurement is calibrated in accordance with the requirements of C63.5:2017

1.7 Measurement Uncertainty

The measurement uncertainties shown below were calculated in accordance with the requirements of ANSI C63.4-2014. All measurement uncertainty values are shown with a coverage factor of $k = 2$ to indicate a 95 % level of confidence. The measurement data shown herein meets or exceeds the U_{CISPR} measurement uncertainty values specified in CISPR 16-4-2 and, thus, can be compared directly to specified limits to determine compliance.

Parameter	Expanded Uncertainty
Conducted Emission (0.15 MHz to 30 MHz)	1.80 dB
Radiated Emissions (30 MHz to 1 GHz)	4.80 dB
Radiated Emissions (1 GHz to 18 GHz)	5.40 dB
Radiated Emissions (18 GHz to 40 GHz)	5.70 dB

2. DESCRIPTION OF TEST

2.1 Measurement of Conducted Emission

The test procedure was in accordance with ANSI C63.4-2014, Clause 7.3

- a. The EUT was placed 0.4 meters from the conducting wall of the shielded room with EUT being connected to the power mains through a line impedance stabilization network (LISN).
If the EUT is connected to the PC through USB, the AC power-line adapter of the PC is directly connected to a line impedance stabilization network (LISN).
Other support units were connected to the power mains through another LISN. The two LISNs provide 50 Ohm/50uH of coupling impedance for the measuring instrument.
- b. Both conducted lines are measured in Quasi-Peak and Average mode, including the worst-case data points for each tested configuration.
- c. The frequency range from 150 kHz to 30 MHz was searched.

Conducted Emission Limits

Frequency (MHz)	Resolution Bandwidth (kHz)	Class A		Class B	
		Quasi-Peak (dB μ V)	Average (dB μ V)	Quasi-Peak (dB μ V)	Average (dB μ V)
0.15 to 0.5	9	79	66	66 to 56*	56 to 46*
0.5 to 5	9	73	60	56	46
5 to 30	9	73	60	60	50

NOTE. Decreases with the logarithm of the frequency.

2.2 Measurement of Radiated Emission

The test procedure was in accordance with ANSI C63.4-2014, Clause 8.3

- a. The EUT was placed on the top of a turn table 0.8 meters above the ground at a semi-anechoic chamber. The table was rotated 360 degrees to determine the position of the highest radiation.
- b. The EUT was set 3 m away from the interference-receiving antenna, which was mounted on the top of a variable-height antenna tower.
- c. The antenna height is varied from 1 m to 4 m above the ground to determine the maximum value of the field strength. Both horizontal and vertical polarizations of the antenna are set to make the measurement.
- d. For each suspected emission, the EUT was arranged to its worst case and then the antenna was tuned to heights from 1 m to 4 m and the turn table was turned from 0 degrees to 360 degrees to find the maximum reading.
- e. The test-receiver system was set to Quasi-Peak detect function and specified bandwidth with maximum hold mode when the test frequency is below 1 GHz.
- f. The test-receiver system was set to Peak and Average detect function and specified bandwidth with maximum hold mode when the test frequency is above 1 GHz.
- g. Place the measurement antenna away from each area of the EUT determined to be a source of emissions at the specified measurement distance, while keeping the measurement antenna aimed at the source of emissions at each frequency of significant emissions, with polarization oriented for maximum response.
(1 GHz to 40 GHz)

Radiated Emission Limits

Frequency (MHz)	Class A			Class B		
	Antenna Distance (m)	Field Strength ($\mu\text{V}/\text{m}$)	Quasi-Peak ($\text{dB}\mu\text{V}/\text{m}$)	Antenna Distance (m)	Field Strength ($\mu\text{V}/\text{m}$)	Quasi-Peak ($\text{dB}\mu\text{V}/\text{m}$)
30 to 88	10	90	39.0	3	100	40.0
88 to 216	10	150	43.5	3	150	43.5
216 to 960	10	210	46.4	3	200	46.0
Above 960	10	300	49.5	3	500	54.0
Frequency (MHz)	Antenna Distance (m)	Class A		Class B		
		Peak ($\text{dB}\mu\text{V}/\text{m}$)	Average ($\text{dB}\mu\text{V}/\text{m}$)	Peak ($\text{dB}\mu\text{V}/\text{m}$)	Average ($\text{dB}\mu\text{V}/\text{m}$)	
Above 1 000	3	80	60	74	54	

This report only responds to the tested sample and may not be reproduced, except in full, without written approval of the HCT Co., Ltd.

2.2.1 Frequency Range of Radiated Measurements

An unintentional radiator, including a digital device, the spectrum shall be investigated from the lowest radio frequency signal generated or used in the device, without going below the lowest frequency for which a Radiated Emission limit is specified, up to the frequency shown in the following table

Highest frequency generated or used in the device or on which the device operates or tunes (MHz)	Upper frequency of measurement range (MHz)
Below 1.705	30
1.705 to 108	1 000
108 to 500	2 000
500 to 1 000	5 000
Above 1 000	5th harmonic of the highest frequency or 40 GHz, whichever is lower

2.3 Configuration of Tested System

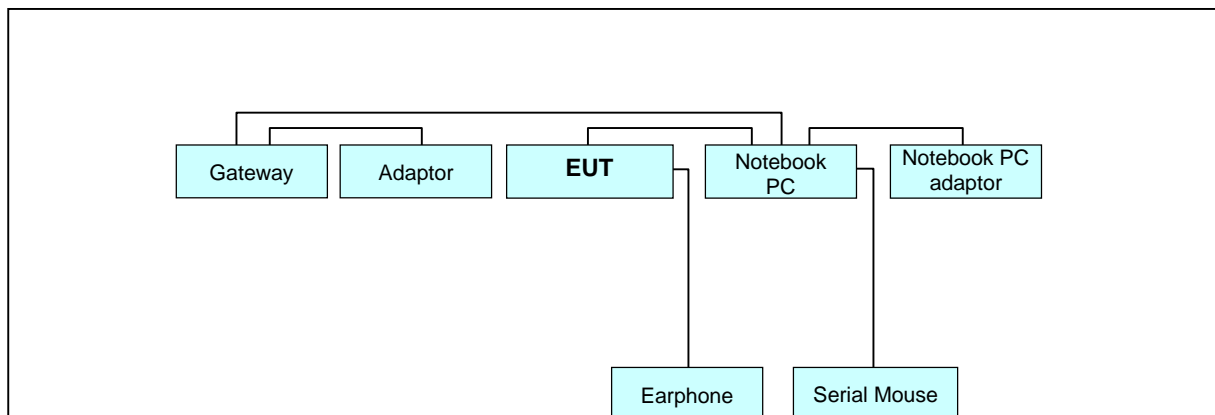

Non-Conductive Table

Power Line: 120 VAC, 60 Hz

3. PRELIMINARY TEST

3.1 Conducted Emission

It was tested the following operating mode, after connecting all peripheral devices.

Operating Modes: Data Communication mode

3.2 Radiated Emission

It was tested the following operating mode, after connecting all peripheral devices.

Operating Modes: Data Communication mode

4. CONDUCTED EMISSION AND RADIATED EMISSION TEST SUMMARY

4.1 Conducted Emission

4.1.1 Measuring instruments

	Type	Manufacturer	Model Name	Serial Number	Calibration Cycle	Calibration Date
<input checked="" type="checkbox"/>	EMI Test Receiver	Rohde & Schwarz	ESCI	100584	1 year	06.18.2019
<input checked="" type="checkbox"/>	LISN	Rohde & Schwarz	ENV216	102245	1 year	12.12.2018
<input checked="" type="checkbox"/>	LISN	Rohde & Schwarz	ENV216	100073	1 year	04.30.2019
<input checked="" type="checkbox"/>	Software	Rohde & Schwarz	EMC32 VER8.54.0	-	-	-

4.1.2 Operating Condition

The test results of conducted emission at mains ports provide the following information:

Test Standard Used	FCC CFR 47 PART 15 Subpart B Class B ANSI C63.4-2014
Detector	Quasi-Peak, CISPR-Average
Bandwidth	9 kHz (6 dB)
Operating Mode	Data Communication mode
Worst case of Data Cable	Luxshare (EAD64746102)
Kind of Test Site	EMI Shielded Room
Temperature	25.2 °C
Relative Humidity	43.8 %
Test Date	July 16, 2019

4.1.3 Measuring Data

Figure 1: Conducted Emission, AC Main Port, Line (L1)

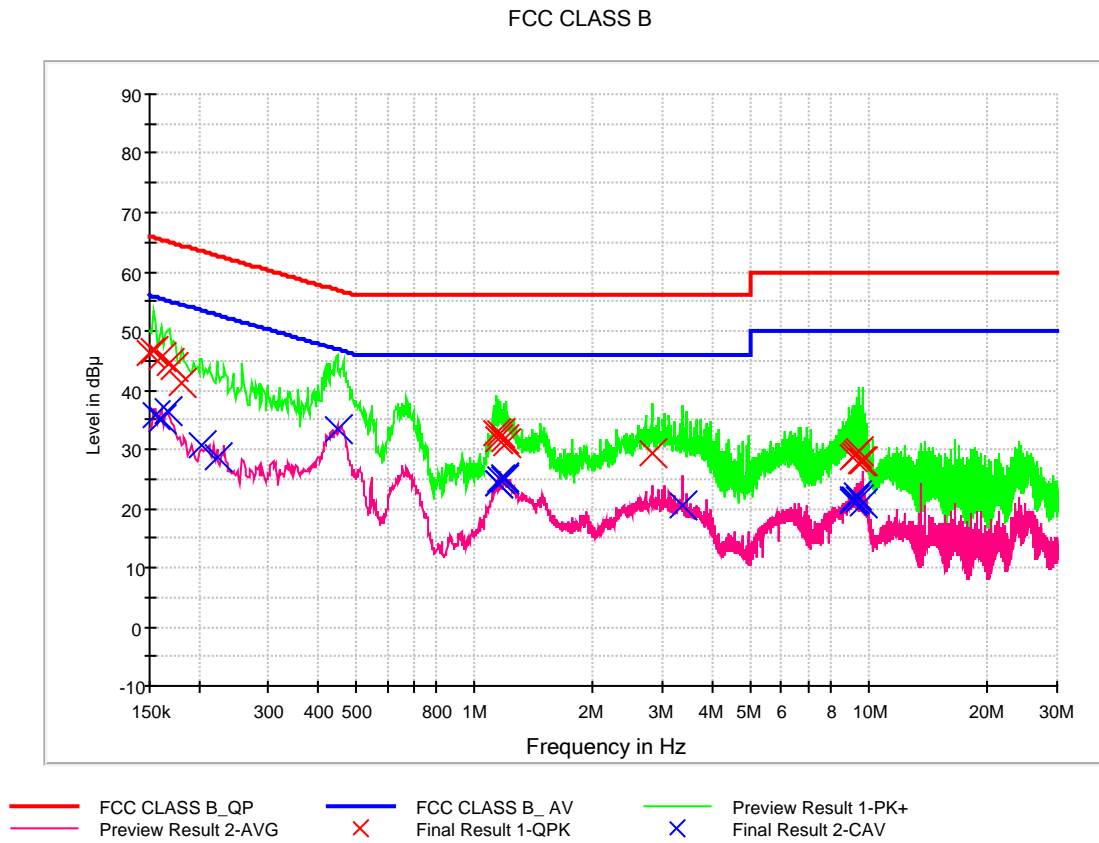

This report only responds to the tested sample and may not be reproduced, except in full, without written approval of the HCT Co., Ltd.

QuasiPeak Final Result, Line (L1)

Frequency (MHz)	QuasiPeak (dB μ V)	Bandwidth (kHz)	Line	Corr. (dB)	Margin (dB)	Limit (dB μ V)
0.150000	46.2	9.000	L1	9.6	19.8	66.0
0.154000	46.7	9.000	L1	9.6	19.0	65.8
0.160000	45.7	9.000	L1	9.6	19.8	65.5
0.168000	44.7	9.000	L1	9.6	20.4	65.1
0.172000	43.9	9.000	L1	9.6	21.0	64.9
0.180000	41.2	9.000	L1	9.6	23.3	64.5
1.140000	32.8	9.000	L1	9.7	23.2	56.0
1.152000	31.8	9.000	L1	9.7	24.2	56.0
1.162000	32.8	9.000	L1	9.7	23.2	56.0
1.192000	31.6	9.000	L1	9.7	24.4	56.0
1.200000	31.0	9.000	L1	9.7	25.0	56.0
2.814000	29.4	9.000	L1	9.8	26.6	56.0
9.122000	28.8	9.000	L1	9.9	31.2	60.0
9.186000	29.1	9.000	L1	9.9	30.9	60.0
9.330000	29.3	9.000	L1	10.0	30.7	60.0
9.386000	29.8	9.000	L1	10.0	30.2	60.0
9.538000	28.0	9.000	L1	10.0	32.0	60.0
9.638000	27.9	9.000	L1	10.0	32.1	60.0

Calculation Formula:

1. Conductor L1 = Hot, Conductor N = Neutral
2. Corr. = LISN Factor + Cable Loss
3. QuasiPeak or CAverage= Receiver Reading + Corr.
4. Margin = Limit – QuasiPeak or CAverage

CAverage Final Result, Line (L1)

Frequency (MHz)	CAverage (dB μ V)	Bandwidth (kHz)	Line	Corr. (dB)	Margin (dB)	Limit (dB μ V)
0.156000	35.9	9.000	L1	9.6	19.7	55.7
0.160000	34.9	9.000	L1	9.6	20.5	55.5
0.166000	36.4	9.000	L1	9.6	18.8	55.2
0.204000	30.8	9.000	L1	9.7	22.7	53.4
0.222000	28.7	9.000	L1	9.7	24.0	52.7
0.448000	33.3	9.000	L1	9.7	13.6	46.9
1.148000	24.3	9.000	L1	9.7	21.7	46.0
1.152000	24.2	9.000	L1	9.7	21.8	46.0
1.162000	25.1	9.000	L1	9.7	20.9	46.0
1.184000	24.9	9.000	L1	9.7	21.1	46.0
1.192000	25.1	9.000	L1	9.7	20.9	46.0
3.352000	20.5	9.000	L1	9.8	25.5	46.0
9.102000	21.2	9.000	L1	9.9	28.8	50.0
9.122000	21.4	9.000	L1	9.9	28.6	50.0
9.186000	21.5	9.000	L1	9.9	28.5	50.0
9.328000	22.3	9.000	L1	10.0	27.7	50.0
9.386000	21.5	9.000	L1	10.0	28.5	50.0
9.638000	20.9	9.000	L1	10.0	29.1	50.0

Figure 2: Conducted Emission, AC Main Port, Line (N)

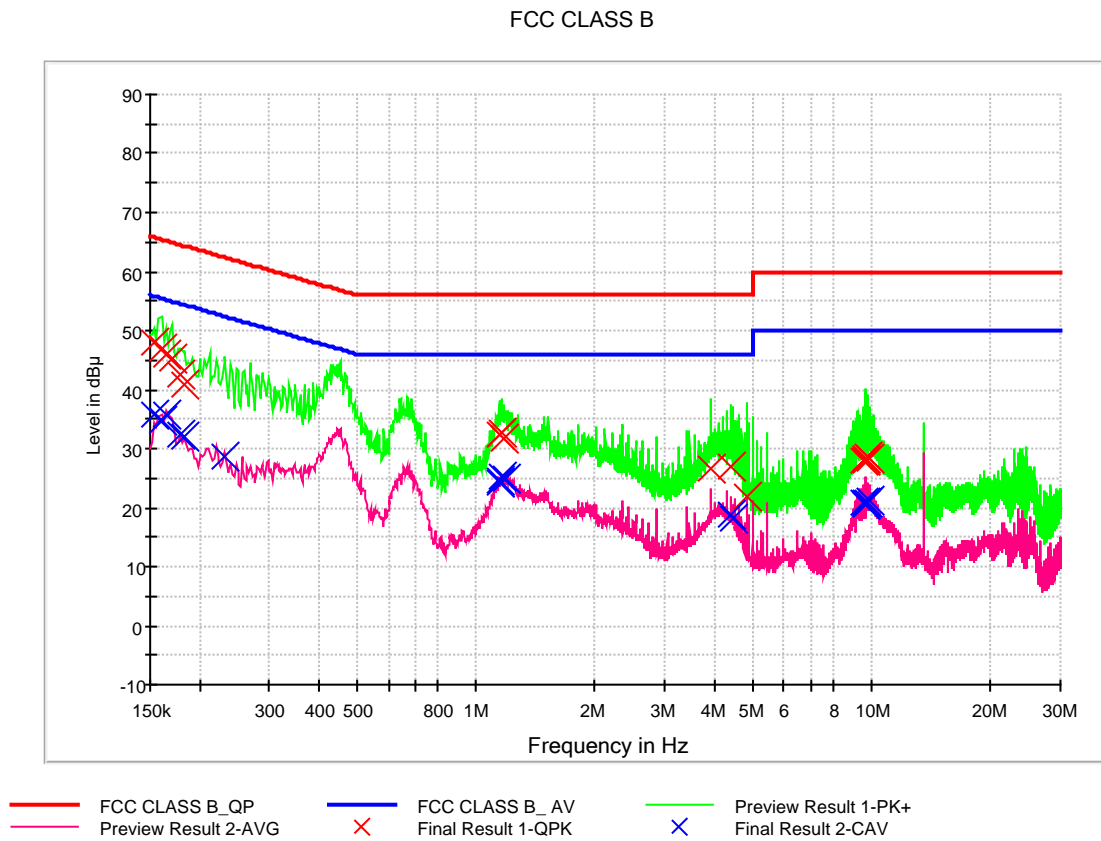

This report only responds to the tested sample and may not be reproduced, except in full, without written approval of the HCT Co., Ltd.

QuasiPeak Final Result, Line (N)

Frequency (MHz)	QuasiPeak (dB μ V)	Bandwidth (kHz)	Line	Corr. (dB)	Margin (dB)	Limit (dB μ V)
0.154000	48.1	9.000	N	9.6	17.7	65.8
0.160000	46.9	9.000	N	9.6	18.6	65.5
0.164000	46.1	9.000	N	9.6	19.2	65.3
0.170000	45.2	9.000	N	9.6	19.8	65.0
0.178000	42.4	9.000	N	9.6	22.2	64.6
0.184000	41.0	9.000	N	9.6	23.3	64.3
1.142000	32.5	9.000	N	9.7	23.5	56.0
1.162000	32.7	9.000	N	9.7	23.3	56.0
1.174000	31.8	9.000	N	9.7	24.2	56.0
3.930000	26.6	9.000	N	9.8	29.4	56.0
4.390000	26.9	9.000	N	9.8	29.1	56.0
4.836000	21.9	9.000	N	9.8	34.1	56.0
9.568000	27.9	9.000	N	9.9	32.1	60.0
9.672000	28.2	9.000	N	9.9	31.8	60.0
9.682000	28.2	9.000	N	9.9	31.8	60.0
9.688000	27.9	9.000	N	9.9	32.1	60.0
9.776000	28.6	9.000	N	9.9	31.4	60.0
9.884000	28.4	9.000	N	9.9	31.6	60.0

This report only responds to the tested sample and may not be reproduced, except in full, without written approval of the HCT Co., Ltd.

CAverage Final Result, Line (N)

Frequency (MHz)	CAverage (dB μ V)	Bandwidth (kHz)	Line	Corr. (dB)	Margin (dB)	Limit (dB μ V)
0.154000	35.6	9.000	N	9.6	20.1	55.8
0.160000	34.9	9.000	N	9.6	20.5	55.5
0.164000	35.9	9.000	N	9.6	19.4	55.3
0.178000	32.3	9.000	N	9.6	22.3	54.6
0.184000	32.1	9.000	N	9.6	22.2	54.3
0.232000	28.6	9.000	N	9.6	23.8	52.4
1.142000	24.7	9.000	N	9.7	21.3	46.0
1.154000	24.2	9.000	N	9.7	21.8	46.0
1.164000	25.3	9.000	N	9.7	20.7	46.0
1.192000	25.0	9.000	N	9.7	21.0	46.0
4.390000	19.0	9.000	N	9.8	27.0	46.0
4.460000	18.2	9.000	N	9.8	27.8	46.0
9.568000	20.9	9.000	N	9.9	29.1	50.0
9.672000	20.6	9.000	N	9.9	29.4	50.0
9.682000	20.6	9.000	N	9.9	29.4	50.0
9.688000	20.8	9.000	N	9.9	29.2	50.0
9.776000	21.0	9.000	N	9.9	29.0	50.0
9.884000	21.3	9.000	N	9.9	28.7	50.0

This report only responds to the tested sample and may not be reproduced, except in full, without written approval of the HCT Co., Ltd.

4.2 Radiated Emission Below 1 GHz

4.2.1 Measuring instruments

Type	Manufacturer	Model Name	Serial Number	Calibration Cycle	Calibration Date
<input checked="" type="checkbox"/> EMI test receiver	Rohde & Schwarz	ESU40	100524	1 year	05.17.2019
<input checked="" type="checkbox"/> Trilog antenna	Schwarzbeck	VULB 9168	255	2 year	03.26.2019
<input checked="" type="checkbox"/> Antenna master	INNCO Systems	MA4640-XP-ET	-	N/A	-
<input checked="" type="checkbox"/> Antenna master controller	INNCO Systems	CO3000	CO3000/870/ 35990515/L	N/A	-
<input checked="" type="checkbox"/> Turn Table	INNCO Systems	1060	-	N/A	-
<input checked="" type="checkbox"/> Turn table controller	INNCO Systems	CO2000	CO2000/095/ 7590304/L	N/A	-
<input checked="" type="checkbox"/> Software	Rohde & Schwarz	EMC32 VER8.40.0	-	-	-

4.2.2 Operating Condition

The test results of radiated emission provide the following information:

Used Test Standard	FCC CFR 47 PART 15 Subpart B Class B ANSI C63.4-2014
Detector	Quasi-Peak
Bandwidth	120 kHz (6 dB)
Operating Mode	Data Communication mode
Worst case of Data Cable	Luxshare (EAD64746102)
Kind of Test Site	3 m semi anechoic chamber
Temperature	21.3 °C
Relative Humidity	41.8 %
Test Date	July 23, 2019

This report only responds to the tested sample and may not be reproduced, except in full, without written approval of the HCT Co., Ltd.

4.2.3 Measuring Data

Frequency (MHz)	Quasi Peak (dB μ V/m)	Antenna Height (cm)	POL. (H/V)	Azimuth (deg)	Corr. (dB)	Margin (dB)	Limit (dB μ V/m)
77.385600	30.4	274.7	H	296.0	16.4	9.6	40.0
265.593600	35.4	125.1	H	141.0	19.3	10.6	46.0
276.760000	30.3	100.0	H	325.0	19.7	15.7	46.0
365.764800	28.0	100.0	H	96.0	22.1	18.0	46.0
480.008800	33.2	100.0	H	324.0	24.8	12.8	46.0
719.996000	36.4	100.0	H	0.0	29.1	9.6	46.0

- Calculation Formula:

1. POL. H = Horizontal, POL. V = Vertical
2. QuasiPeak = Reading (Receiver Reading) + Corr.
3. Corr. (Correction Factor) = Antenna Factor + Cable Loss
4. Margin = Limit - QuasiPeak

4.3 Radiated Emission Above 1 GHz

4.3.1 Measuring instruments

	Type	Manufacturer	Model Name	Serial Number	Calibration Cycle	Calibration Date
<input checked="" type="checkbox"/>	EMI test receiver	Rohde & Schwarz	ESU40	100524	1 year	05.17.2019
<input checked="" type="checkbox"/>	Antenna master	INNCO Systems	MA4640-XP-ET	-	N/A	-
<input checked="" type="checkbox"/>	Antenna master controller	INNCO Systems	CO3000	CO3000/870/ 35990515/L	N/A	-
<input checked="" type="checkbox"/>	Turn table	INNCO Systems	1060	-	N/A	-
<input checked="" type="checkbox"/>	Turn table controller	INNCO Systems	CO2000	CO2000/095/ 7590304/L	N/A	-
<input checked="" type="checkbox"/>	Horn antenna	Schwarzbeck	BBHA 9120D	01836	1 year	07.19.2019
<input checked="" type="checkbox"/>	Low Noise amplifier	TESTEK	TK-PA18H	170034-L	1 year	03.04.2019
<input checked="" type="checkbox"/>	Power Amplifier	TK-PA1840H	TESTEK	170030-L	1 year	12.17.2018
<input checked="" type="checkbox"/>	Horn Antenna	BBHA 9170	Schwarzbeck	BBHA 9170 #786	2 year	12.05.2017
<input checked="" type="checkbox"/>	Software	Rohde & Schwarz	EMC32 VER8.40.0	-	-	-

4.3.2 Operating Condition

The test results of radiated emission provide the following information:

Used Test Standard	FCC CFR 47 PART 15 Subpart B Class B ANSI C63.4-2014
Detector	Peak mode: Peak (RBW: 1 MHz, VBW: 3 MHz) CISPR-Average mode: Peak (RBW: 1 MHz, VBW: 10 Hz)
Highest Frequency	5 825 MHz
Tested Frequency Range	1 GHz to 30 GHz
Operation Mode	Data Communication mode
Worst case of Data Cable	Luxshare (EAD64746102)
Kind of Test Site	3 m semi anechoic chamber
Temperature	21.3 °C
Relative Humidity	41.8 %
Test Date	July 23, 2019

4.3.3 Measuring Data

Frequency (MHz)	Peak (dB μ V/m)	Antenna Height (cm)	POL. (H/V)	Azimuth (deg)	Corr. (dB)	Margin (dB)	Limit (dB μ V/m)
1329.120000	47.0	137.6	V	102.0	-26.3	27.0	74.0
1990.990000	50.8	100.0	V	49.0	-25.2	23.2	74.0
2665.245000	49.7	198.6	V	17.0	-22.6	24.3	74.0
4481.625000	41.5	279.6	V	112.0	-17.5	32.5	74.0
5994.165000	45.5	288.4	V	113.0	-14.7	28.5	74.0
9752.600000	47.1	277.5	H	226.0	-5.1	26.9	74.0

Frequency (MHz)	CAverage (dB μ V/m)	Antenna Height (cm)	POL. (H/V)	Azimuth (deg)	Corr. (dB)	Margin (dB)	Limit (dB μ V/m)
1329.120000	20.7	137.6	V	102.0	-26.3	33.3	54.0
1990.990000	23.0	100.0	V	49.0	-25.2	31.0	54.0
2665.245000	23.2	198.6	V	17.0	-22.6	30.8	54.0
4481.625000	26.0	279.6	V	112.0	-17.5	28.0	54.0
5994.165000	29.1	288.4	V	113.0	-14.7	24.9	54.0
9752.600000	34.2	277.5	H	226.0	-5.1	19.8	54.0

- Calculation Formula:

1. POL. H = Horizontal, POL. V = Vertical
2. Peak or CAverage = Reading (Receiver Reading) + Corr.
3. Corr. (Correction Factor) = Antenna Factor+ Cable Loss –Amplifier Gain
4. Margin = Limit - Peak or CAverage

5. CONCLUSION

The data collected shows that the **Product Name: Multi-band WCDMA/LTE Tablet with BT and WiFi,**
Model Name: LM-T600US complies with §15.107 and §15.109 of the FCC rules.

6. APPENDIX A. TEST SETUP PHOTO

Please refer to Appendix. A and test setup photo file no. as follows;

File No.	Date of Issue	Description
HCT-EM-1907-FC015-P	July 26, 2019	Initial Release

End of report