

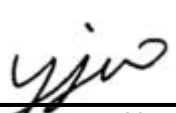



# SAR TEST REPORT

HCT CO., LTD

EUT Type:	Cellular/PCS GSM/GPRS/EDGE(RX Only) Phone with Bluetooth, WLAN.	
FCC ID:	ZNFT585	
Model:	LG -T585	
Additional Model	T585, LGT585, LG-T580, T580, LGT580	
Date of Issue:	Jul. 12, 2013	
Test report No.:	HCTA1307FS03	
Test Laboratory:	<b>HCT CO., LTD.</b> 74, Seoicheon-ro 578 beon-gil, Majang-myeon, Icheon-si, Gyeonggi-do, Korea 467-811 TEL: +82 31 645 6300 FAX: +82 31 645 6401	
Applicant :	<b>LG Electronics, MobileComm U.S.A., Inc.</b> 1000 Sylvan Avenue, Englewood Cliffs NJ 07632	
Testing has been carried out in accordance with:	RSS-102 Issue 4; Health Canada Safety Code 6 47CFR §2.1093 FCC OET Bulletin 65(Edition 97-01), Supplement C (Edition 01-01) ANSI/ IEEE C95.1 – 1992 IEEE 1528-2003	
Test result:	The tested device complies with the requirements in respect of all parameters subject to the test. The test results and statements relate only to the items tested. The test report shall not be reproduced except in full, without written approval of the laboratory.	
Signature	 _____ Report prepared by : Yun-Jeang Heo Test Engineer of SAR Part	 _____ Approved by : Jae-Sang So Manager of SAR Part

---

# Table of Contents

---

1. INTRODUCTION .....	4
2. TEST METHODOLOGY .....	5
3. DESCRIPTION OF DEVICE.....	6
4. DESCRIPTION OF TEST EQUIPMENT .....	7
5. SAR MEASUREMENT PROCEDURE.....	14
6. DESCRIPTION OF TEST POSITION.....	16
7. MEASUREMENT UNCERTAINTY .....	18
8. ANSI/ IEEE C95.1 - 1992 RF EXPOSURE LIMITS .....	19
9. SAR SYSTEM VALIDATION.....	20
10. SYSTEM VERIFICATION.....	21
11. RF CONDUCTED POWER MEASUREMENT .....	23
12. SAR Test configuration & Antenna Information .....	29
13. SAR TEST DATA SUMMARY .....	30
13.1 Measurement Results (GSM 850 Head SAR) .....	30
13.2 Measurement Results (GSM 1 900 Head SAR) .....	31
13.3 Measurement Results (802.11b/g Head SAR) .....	32
13.4 Measurement Results (Body-worn SAR) .....	33
14. SAR Measurement Variability and Uncertainty.....	34
15. SAR Summation Scenario .....	35
16. CONCLUSION.....	38
17. REFERENCES .....	39
Attachment 1. – SAR Test Plots .....	40
Attachment 2. – Dipole Verification Plots.....	54
Attachment 3. – Probe Calibration Data .....	61
Attachment 4. – Dipole Calibration Data .....	73

# Version

Rev	DATE	DESCRIPTION
	Jul. 04, 2013	First Approval Report
1	Jul. 10. 2013	Page 6, 21, 28, 29, 33, 37 and 46 are revised.
2	Jul. 12. 2013	Page 5 and 28 are revised.

# 1. INTRODUCTION

The FCC has adopted the guidelines for evaluating the environmental effects of radio frequency radiation in ET Docket 93-62 on Aug. 6, 1996 to protect the public and workers from the potential hazards of RF emissions due to FCC-regulated portable devices.

The safety limits used for the environmental evaluation measurements are based on the criteria published by the American National Standards Institute (ANSI) for localized specific absorption rate (SAR) in IEEE/ANSI C95.1-1992 Standard for Safety Levels with Respect to Human Exposure to Radio Frequency Electromagnetic Fields, 3 kHz to 300 GHz. 1992 by the Institute of Electrical and Electronics Engineers, Inc., New York, New York 10017. The measurement procedure described in IEEE/ANSI C95.3-1992 Recommended Practice for the Measurement of Potentially Hazardous Electromagnetic Fields - RF and Microwave is used for guidance in measuring SAR due to the RF radiation exposure from the Equipment Under Test (EUT). These criteria for SAR evaluation are similar to those recommended by the National Council on Radiation Protection and Measurements (NCRP) in Biological Effects and Exposure Criteria for Radio frequency Electromagnetic Fields," NCRP Report No. 86 NCRP, 1986, Bethesda, MD 20814. SAR is a measure of the rate of energy absorption due to exposure to an RF transmitting source. SAR values have been related to threshold levels for potential biological hazards.

## SAR Definition

Specific Absorption Rate (SAR) is defined as the time derivative of the incremental electromagnetic energy (dW) absorbed by (dissipated in) an incremental mass (dm) contained in a volume element (dV) of a given density (ρ). It is also defined as the rate of RF energy absorption per unit mass at a point in an absorbing body.

$$SAR = \frac{d}{dt} \left( \frac{dU}{dm} \right) = \frac{d}{dt} \left( \frac{dU}{\rho dV} \right)$$

**Figure 2. SAR Mathematical Equation**

**SAR is expressed in units of Watts per Kilogram (W/kg).**

where:

$$SAR = \sigma E^2 / \rho$$

$\sigma$  = conductivity of the tissue-simulant material (S/m)  
 $\rho$  = mass density of the tissue-simulant material (kg/m<sup>3</sup>)  
 $E$  = Total RMS electric field strength (V/m)

NOTE: The primary factors that control rate of energy absorption were found to be the wavelength of the incident field in relations to the dimensions and geometry of the irradiated organism, the orientation of the organism in relation to the polarity of field vectors, the presence of reflecting surfaces, and whether conductive contact is made by the organism with a ground plane.

## **2. TEST METHODOLOGY**

---

The tests documented in this report were performed in accordance with FCC OET Bulletin 65 Supplement C 01-01, IEEE Standard 1528-2003 & IEEE 1528a-2005 and the following published KDB procedures.

- FCC KDB Publication 941225 D01 SAR test for 3G devices v02
- FCC KDB Publication 941225 D02 HSPA and 1x Advanced v02r02
- FCC KDB Publication 941225 D03 SAR Test Reduction GSM GPRS EDGE v01
- FCC KDB Publication 941225 D04 SAR for GSM E GPRS Dual Xfer Mode v01
- FCC KDB Publication 248227 D01v01r02(SAR Consideration for 802.11 Devices)
- FCC KDB Publication 447498 D01 General RF Exposure v05r01
- FCC KDB Publication 648474 D04 Handset SAR v01r01
- FCC KDB Publication 865664 D01 SAR Measurement 100 MHz to 6 GHz v01r01
- FCC KDB Publication 865664 D02 RF Exposure Reporting v01r01

### 3. DESCRIPTION OF DEVICE

Environmental evaluation measurements of specific absorption rate (SAR) distributions in emulated human head and body tissues exposed to radio frequency (RF) radiation from wireless portable devices for compliance with the rules and regulations of the U.S. Federal Communications Commission (FCC).

EUT Type	Cellular/PCS GSM/GPRS/EDGE(RX Only) Phone with Bluetooth, WLAN.				
FCC ID:	ZNFT585				
Model:	LG-T585				
Trade Name	LG Electronics, MobileComm U.S.A., Inc.				
Application Type	Certification				
Mode(s) of Operation	GSM850/ GSM1900/ 802.11b/g				
Tx Frequency	824.20 - 848.80 MHz (GSM850)/ 1 850.20 – 1 909.80 MHz (GSM1900) 2 412- 2 462 MHz (802.11b/g)				
Rx Frequency	869.20 - 893.80 MHz (GSM850)/ 1 930.20 – 1 989.80 MHz (GSM1900) 2 412- 2 462 MHz (802.11b/g)				
Production Unit or Identical Prototype	Prototype				
Max SAR	Band	Tx Frequency (MHz)	Equipment Class	Reported 1 g SAR (W/kg)	
				Head	Body-worn
	GSM850	824.20 - 848.80	PCE	0.47	0.50
	GSM1900	1 850.20 -1 909.80	PCE	0.97	0.26
	Bluetooth	2 402 - 2 480	DSS	-	
	802.11b	2 412- 2 462	DTS	0.48	0.07
Simultaneous SAR per KDB 690783 D01				1.15	0.57
Date(s) of Tests	Jun. 26, 2013 ~ Jun. 28, 2013				
Antenna Type	Integral Antenna				
GPRS	Multislot Class: 12 Mode Class B				
Key Feature(s)	-				

## 4. DESCRIPTION OF TEST EQUIPMENT

### 4.1 SAR MEASUREMENT SETUP

These measurements are performed using the DASY4 automated dosimetric assessment system. It is made by Schmid & Partner Engineering AG (SPEAG) in Zurich, Switzerland. It consists of high precision robotics system (Staubli), robot controller, Pentium III computer, near-field probe, probe alignment sensor, and the generic twin phantom containing the brain equivalent material. The robot is a six-axis industrial robot performing precise movements to position the probe to the location (points) of maximum electromagnetic field (EMF) (see Figure.4.1).

A cell controller system contains the power supply, robot controller, teach pendant (Joystick), and remote control, is used to drive the robot motors. The PC consists of the HP Pentium IV 3.0 GHz computer with Windows XP system and SAR Measurement Software DASY4, A/D interface card, monitor, mouse, and keyboard. The Staubli Robot is connected to the cell controller to allow software manipulation of the robot. A data acquisition electronic (DAE) circuit performs the signal amplification, signal multiplexing, AD-conversion, offset measurements, mechanical surface detection, collision detection, etc. is connected to the Electro-optical coupler (EOC). The EOC performs the conversion from the optical into digital electric signal of the DAE and transfers data to the PC plug-in card.

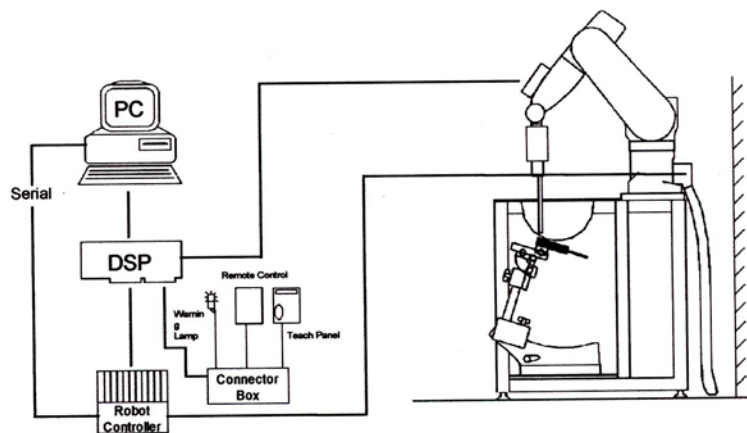

Figure 4.1 HCT SAR Lab. Test Measurement Set-up

The DAE4 consists of a highly sensitive electrometer-grade preamplifier with auto-zeroing, a channel and gain-switching multiplexer, a fast 16 bit AD-converter and a command decoder and control logic unit. Transmission to the PC-card is accomplished through an optical downlink for data and status information and an optical uplink for commands and clock lines. The mechanical probe mounting device includes two different sensor systems for frontal and sidewise probe contacts. They are also used for mechanical surface detection and probe collision detection. The robot uses its own controller with a built in VME-bus computer. The system is described in detail in.

## 4.2 DASYS4 E-FIELD PROBE SYSTEM

### 4.2.1 ET3DV4 Probe Specification

Construction	Symmetrical design with triangular core Interleaved sensors Built-in shielding against static charges PEEK enclosure material (resistant to organic solvents, e.g., DGBE)
Calibration	Basic Broad Band Calibration in air Conversion Factors (CF) for HSL 900 and HSL 1810 Additional CF for other liquids and frequencies upon request
Frequency	10 MHz to 4 GHz; Linearity: $\pm 0.2$ dB (30 MHz to 4 GHz)
Directivity	$\pm 0.2$ dB in HSL (rotation around probe axis) $\pm 0.3$ dB in tissue material (rotation normal to probe axis)
Dynamic Range	5 $\mu$ W/g to > 100 mW/g; Linearity: $\pm 0.2$ dB
Dimensions	Overall length: 330 mm (Tip: 20 mm) Tip diameter: 3.9 mm (Body: 12 mm) Distance from probe tip to dipole centers: 2.0 mm
Application	General dosimetry up to 4 GHz Dosimetry in strong gradient fields Compliance tests of mobile phones

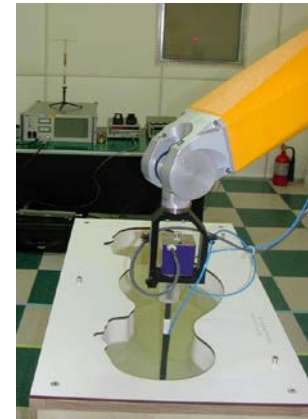

Figure 4.2 Photograph of the probe and the Phantom



Figure 3.3 ET3DV6 E-field Probe

The SAR measurements were conducted with the dosimetric probe ET3DV6, designed in the classical triangular configuration and optimized for dosimetric evaluation. The probe is constructed using the thick film technique; with printed resistive lines on ceramic substrates. The probe is equipped with an optical multifiber line ending at the front of the probe tip. It is connected to the EOC box on the robot arm and provides an automatic detection of the phantom surface. Half of the fibers are connected to a pulsed infrared transmitter, the other half to a synchronized receiver. As the probe approaches the surface, the reflection from the surface produces a coupling from the transmitting to the receiving fibers. This reflection increases first during the approach, reaches a maximum and then decreases. If the probe is flatly touching the surface, the coupling is zero. The distance of the coupling maximum to the surface is independent of the surface reflectivity and largely independent of the surface to probe angle. The DASYS4 software reads the reflection during a software approach and looks for the maximum using a 2<sup>nd</sup> order fitting. The approach is stopped at reaching the maximum.



## 4.3 PROBE CALIBRATION PROCESS

### 4.3.1 E-Probe Calibration

Each probe is calibrated according to a dosimetric assessment procedure with an accuracy better than ± 10 %. The spherical isotropy was evaluated with the proper procedure and found to be better than ± 0.25 dB. The sensitivity parameters (NormX, NormY, NormZ), the diode compression parameter (DCP) and the conversion factor (ConvF) of the probe is tested.

The free space E-field from amplified probe outputs is determined in a test chamber. This is performed in a TEM cell for frequencies bellow 1 GHz, and in a waveguide above 1 GHz for free space. For the free space calibration, the probe is placed in the volumetric center of the cavity and at the proper orientation with the field. The probe is then rotated 360 degrees.

E-field temperature correlation calibration is performed in a flat phantom filled with the appropriate simulated brain tissue. The measured free space E-field in the medium correlates to temperature rise in a dielectric medium. For temperature correlation calibration a RF transparent thermistor-based temperature probe is used in conjunction with the E-field probe.

$$SAR = C \frac{\Delta T}{\Delta t}$$

where:

- $\Delta t$  = exposure time (30 seconds),
- C = heat capacity of tissue (brain or muscle),
- $\Delta T$  = temperature increase due to RF exposure.

SAR is proportional to  $\Delta T / \Delta t$ , the initial rate of tissue heating, before thermal diffusion takes place. Now it's possible to quantify the electric field in the simulated tissue by equating the thermally derived SAR to the E- field;

$$SAR = \frac{|E|^2 \cdot \sigma}{\rho}$$

where:

- $\sigma$  = simulated tissue conductivity,
- $\rho$  = Tissue density (1.25 g/cm<sup>3</sup> for brain tissue)

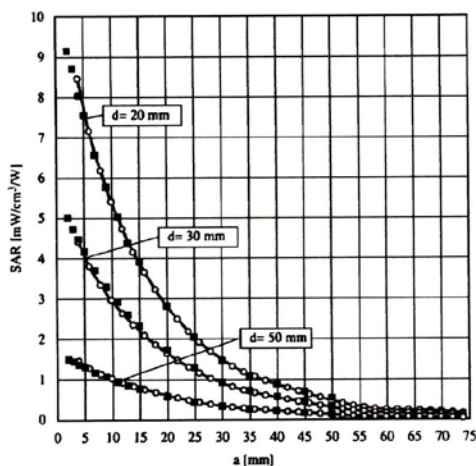

Figure 4.4 E-Field and Temperature measurements at 900 MHz

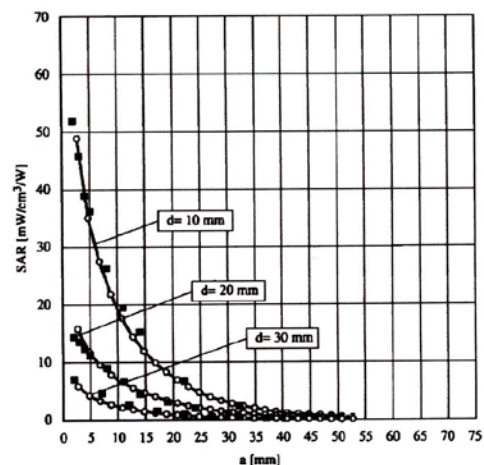

Figure 4.5 E-Field and temperature measurements at 1.8 GHz

### 4.3.2 Data Extrapolation

The DASY4 software automatically executes the following procedures to calculate the field units from the microvolt readings at the probe connector. The first step of the evaluation is a linearization of the filtered input signal to account for the compression characteristics of the detector diode. The compensation depends on the input signal, the diode type and the DC-transmission factor from the diode to the evaluation electronics. If the exciting field is pulsed, the crest factor of the signal must be known to correctly compensate for peak power. The formula for each channel can be given like below;

$$V_i = U_i + U_i^2 \cdot \frac{cf}{dcp_i}$$

with  $V_i$  = compensated signal of channel i (i=x,y,z)  
 $U_i$  = input signal of channel i (i=x,y,z)  
 $cf$  = crest factor of exciting field (DASY parameter)  
 $dcp_i$  = diode compression point (DASY parameter)

From the compensated input signals the primary field data for each channel can be evaluated:

E-field probes:

$$E_i = \sqrt{\frac{V_i}{Norm_i \cdot ConvF}}$$

with  $V_i$  = compensated signal of channel i (i = x,y,z)  
 $Norm_i$  = sensor sensitivity of channel i (i = x,y,z)  
 $\mu V/(V/m)^2$  for E-field probes  
 $ConvF$  = sensitivity of enhancement in solution  
 $E_i$  = electric field strength of channel i in V/m

The RSS value of the field components gives the total field strength (Hermetian magnitude):

$$E_{tot} = \sqrt{E_x^2 + E_y^2 + E_z^2}$$

The primary field data are used to calculate the derived field units.

$$SAR = E_{tot}^2 \cdot \frac{\sigma}{\rho \cdot 1000}$$

with  $SAR$  = local specific absorption rate in W/g  
 $E_{tot}$  = total field strength in V/m  
 $\sigma$  = conductivity in [mho/m] or [Siemens/m]  
 $\rho$  = equivalent tissue density in g/cm<sup>3</sup>

The power flow density is calculated assuming the excitation field to be a free space field.

$$P_{pwe} = \frac{E_{tot}^2}{3770}$$

with  $P_{pwe}$  = equivalent power density of a plane wave in W/cm<sup>2</sup>  
 $E_{tot}$  = total electric field strength in V/m

## 4.4 SAM Phantom

The shell corresponds to the specifications of the Specific Anthropomorphic Mannequin (SAM) phantom defined in IEEE 1528 and IEC 62209-1. It enables the dosimetric evaluation of left and right hand phone usage as well as body mounted usage at the flat phantom region. A cover prevents evaporation of the liquid. Reference markings on the phantom allow the complete setup of all predefined phantom positions and measurement grids by teaching three points with the robot.



Shell Thickness	2.0 mm ± 0.2 mm (6 ± 0.2 mm at ear point)	
Filling Volume	about 25 L	
Dimensions	810 mm x 1 000 mm x 500 mm (H x L x W)	Figure 4.6 SAM Phantom

Triple Modular Phantom consists of three identical modules which can be installed and removed separately without emptying the liquid. It includes three reference points for phantom installation. Covers prevent evaporation of the liquid. Phantom material is resistant to DGBE based tissue simulating liquids. The MFP V5.1 will be delivered including wooden support only (**non-standard** SPEAG support).

Applicable for system performance check from 700 MHz to 6 GHz (MFP V5.1C) or 800 MHz - 6 GHz (MFP V5.1A) as well as dosimetric evaluations for body-worn operation.



Shell Thickness	2.0 mm ± 0.2 mm	
Filling Volume	approx. 9.2 L	
Dimensions	830 mm x 500 mm (L x W)	Figure 4.7 Triple Modular Phantom

## 4.5 Device Holder for Transmitters

In combination with the SAM Phantom V 4.0, the Mounting Device (POM) enables the rotation of the mounted transmitter in spherical coordinates whereby the rotation points is the ear opening. The devices can be easily, accurately, and repeatably positioned according to the FCC and CENELEC specifications. The device holder can be locked at different phantom locations (left head, right head, flat phantom).

Note: A simulating human hand is not used due to the complex anatomical and geometrical structure of the hand that may produce an infinite number of configurations. To produce the Worst-case condition (the hand absorbs antenna output power), the hand is omitted during the tests.



Figure 4.8 Device Holder

## 4.6 Brain & Muscle Simulating Mixture Characterization

The brain and muscle mixtures consist of a viscous gel using hydrox-ethyl cellulose (HEC) gelling agent and saline solution (see Table 3.1). Preservation with a bactericide is added and visual inspection is made to make sure air bubbles are not trapped during the mixing process. The mixture is calibrated to obtain proper dielectric constant (permittivity) and conductivity of the desired tissue. The mixture characterizations used for the brain and muscle tissue simulating liquids are according to the data by C. Gabriel and G. Hartsgrove.

Ingredients (% by weight)	Frequency (MHz)					
	835		1 900		2 450 – 2 700	
Tissue Type	Head	Body	Head	Body	Head	Body
Water	40.45	53.06	54.9	70.17	71.88	73.2
Salt (NaCl)	1.45	0.94	0.18	0.39	0.16	0.1
Sugar	57.0	44.9	0.0	0	0.0	0.0
HEC	1.0	1.0	0.0	0	0.0	0.0
Bactericide	0.1	0.1	0.0	0	0.0	0.0
Triton X-100	0.0	0.0	0.0	0.0	19.97	0.0
DGBE	0.0	0.0	44.92	29.44	7.99	26.7
Diethylene glycol hexyl ether	-	-	-	-	-	-

Salt: 99 % Pure Sodium Chloride      Sugar: 98 % Pure Sucrose  
 Water: De-ionized, 16M resistivity      HEC: Hydroxyethyl Cellulose  
 DGBE: 99 % Di(ethylene glycol) butyl ether,[2-(2-butoxyethoxy) ethanol]  
 Triton X-100(ultra pure): Polyethylene glycol mono[4-(1,1,3,3-tetramethylbutyl)phenyl] ether

**Table 4.1 Composition of the Tissue Equivalent Matter**

## 4.7 SAR TEST EQUIPMENT

Manufacturer	Type / Model	S/N	Calib. Date	Calib.Interval	Calib.Due
SPEAG	SAM Phantom	-	N/A	N/A	N/A
Staubli	Robot RX90L	F01/5K09A1/A/01	N/A	N/A	N/A
Staubli	Robot ControllerCS7MB	F99/5A82A1/C/01	N/A	N/A	N/A
HP	Pavilion t000_puffer	KRJ51201TV	N/A	N/A	N/A
SPEAG	Light Alignment Sensor	265	N/A	N/A	N/A
Staubli	Teach Pendant (Joystick)	D221340.01	N/A	N/A	N/A
SPEAG	DAE3	466	Feb. 21, 2013	Annual	Feb. 21, 2014
SPEAG	E-Field Probe ET3DV6	1798	Apr. 29, 2013	Annual	Apr. 29, 2014
SPEAG	Validation Dipole D835V2	441	Apr. 25, 2013	Annual	Apr. 25, 2014
SPEAG	Validation Dipole D1900V2	5d032	Jul. 20, 2012	Annual	Jul. 20, 2013
SPEAG	Validation Dipole D2450V2	743	Aug. 23, 2012	Annual	Aug. 23, 2013
Agilent	Power Meter(F) E4419B	MY41291386	Nov. 02, 2012	Annual	Nov. 02, 2013
Agilent	Power Sensor(G) 8481	MY41090870	Nov. 02, 2012	Annual	Nov. 02, 2013
HP	Dielectric Probe Kit 85070C	00721521	CBT		
HP	Dual Directional Coupler	16072	Nov. 02, 2012	Annual	Nov. 02, 2013
HP	Base Station E5515C	GB44400269	Feb. 14, 2013	Annual	Feb. 14, 2014
HP	Signal Generator 8664A	3744A02069	Nov. 02, 2012	Annual	Nov. 02, 2013
Hewlett Packard	11636B/Power Divider	11377	Nov. 11, 2012	Annual	Nov. 11, 2013
Agilent	N9020A/ SIGNAL	MY51110020	Jul. 31, 2012	Annual	Jul. 31, 2013
TESCOM	TC-3000C / BLUETOOTH	3000C000276	Jul. 11, 2012	Annual	Jul. 11, 2013

**NOTE:**

- The E-field probe was calibrated by SPEAG, by the waveguide technique procedure. Dipole Verification measurement is performed by HCT Lab. before each test. The brain/body simulating material is calibrated by HCT using the dielectric probe system and network analyzer to determine the conductivity and permittivity (dielectric constant) of the brain/body-equivalent material.
- CBT(Calibrating Before Testing). Prior to testing, the dielectric probe kit was calibrated via the network analyzer, with the specified procedure(calibrated in pure water) and calibration kit(standard) short circuit, before the dielectric measurement. The specific procedure and calibration kit are provided by Agilent

## 5. SAR MEASUREMENT PROCEDURE

The evaluation was performed with the following procedure:

1. The SAR value at a fixed location above the ear point was measured and was used as a reference value for assessing the power drop.
2. The SAR distribution at the exposed side of the head was measured at a distance of 3.9 mm from the inner surface of the shell. The area covered the entire dimension of the head and the horizontal grid spacing was 15 mm x 15 mm. Based on this data, the area of the maximum absorption was determined by spline interpolation.
3. Around this point, a volume of 32 mm x 32 mm x 30 mm was assessed by measuring 5 x 5 x 7 points. On this basis of this data set, the spatial peak SAR value was evaluated with the following procedure:
  - a. The data at the surface were extrapolated, since the center of the dipoles is 2.7 mm away from the tip of the probe and the distance between the surface and the lowest measuring point is 1.2 mm. The extrapolation was based on a least square algorithm. A polynomial of the fourth order was calculated through the points in z-axes. This polynomial was then used to evaluate the points between the surface and the probe tip.
  - b. The maximum interpolated value was searched with a straight-forward algorithm. Around this maximum the SAR values averaged over the spatial volumes (1 g or 10 g) were computed using the 3D-Spline interpolation algorithm. The 3D-spline is composed of three one-dimensional splines with the "Not a knot" condition (in x, y, and z directions. The volume was integrated with the trapezoidal algorithm. One thousand points (10 x 10 x 10) were interpolated to calculate the average.
  - c. All neighboring volumes were evaluated until no neighboring volume with a higher average value was found.
4. The SAR value, at the same location as procedure #1, was re-measured. If the value changed by more than 5 %, the evaluation is repeated.

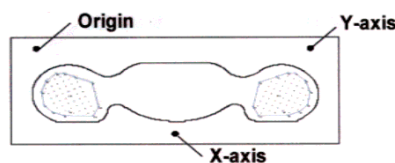

Figure 5.1 SAR Measurement Point in Area Scan

First Area Scan is used to locate the approximate location(s) of the local peak SAR value(s). The measurement grid within an Area Scan is defined by the grid extend, grid step size and grid offset. Next, in order to determine the EM field distribution in a three-dimensional spatial extension, Zoom Scan is required. The Zoom Scan is performed around the highest E-field value to determine the averaged SASR-distribution over 10g.

Area scan and zoom scan resolution setting follow KDB 865664 D01v01 quoted below



		$\leq 3$ GHz	$> 3$ GHz
Maximum distance from closest measurement point (geometric center of probe sensors) to phantom surface		$5 \pm 1$ mm	$\frac{1}{2} \cdot \delta \cdot \ln(2) \pm 0.5$ mm
Maximum probe angle from probe axis to phantom surface normal at the measurement location		$30^\circ \pm 1^\circ$	$20^\circ \pm 1^\circ$
Maximum area scan spatial resolution: $\Delta x_{Area}, \Delta y_{Area}$		$\leq 2$ GHz: $\leq 15$ mm 2 – 3 GHz: $\leq 12$ mm	3 – 4 GHz: $\leq 12$ mm 4 – 6 GHz: $\leq 10$ mm
		When the x or y dimension of the test device, in the measurement plane orientation, is smaller than the above, the measurement resolution must be $\leq$ the corresponding x or y dimension of the test device with at least one measurement point on the test device.	
Maximum zoom scan spatial resolution: $\Delta x_{Zoom}, \Delta y_{Zoom}$		$\leq 2$ GHz: $\leq 8$ mm 2 – 3 GHz: $\leq 5$ mm*	3 – 4 GHz: $\leq 5$ mm* 4 – 6 GHz: $\leq 4$ mm*
Maximum zoom scan spatial resolution, normal to phantom surface	uniform grid: $\Delta z_{Zoom}(n)$	$\leq 5$ mm	3 – 4 GHz: $\leq 4$ mm 4 – 5 GHz: $\leq 3$ mm 5 – 6 GHz: $\leq 2$ mm
	graded grid	$\Delta z_{Zoom}(1)$ : between 1 <sup>st</sup> two points closest to phantom surface	$\leq 4$ mm
		$\Delta z_{Zoom}(n>1)$ : between subsequent points	$\leq 1.5 \cdot \Delta z_{Zoom}(n-1)$
Minimum zoom scan volume	x, y, z	$\geq 30$ mm	3 – 4 GHz: $\geq 28$ mm 4 – 5 GHz: $\geq 25$ mm 5 – 6 GHz: $\geq 22$ mm
<p>Note: <math>\delta</math> is the penetration depth of a plane-wave at normal incidence to the tissue medium; see draft standard IEEE P1528-2011 for details.</p> <p>* When zoom scan is required and the <i>reported</i> SAR from the area scan based <i>1-g SAR estimation</i> procedures of KDB 447498 is <math>\leq 1.4</math> W/kg, <math>\leq 8</math> mm, <math>\leq 7</math> mm and <math>\leq 5</math> mm zoom scan resolution may be applied, respectively, for 2 GHz to 3 GHz, 3 GHz to 4 GHz and 4 GHz to 6 GHz.</p>			

## 6. DESCRIPTION OF TEST POSITION

### 6.1 HEAD POSITION

The device was placed in a normal operating position with the Point A on the device, as illustrated in following drawing, aligned with the location of the RE(ERP) on the phantom. With the ear-piece pressed against the head, the vertical center line of the body of the handset was aligned with an imaginary plane consisting of the RE, LE and M. While maintaining these alignments, the body of the handset was gradually moved towards the cheek until any point on the mouth-piece or keypad contacted the cheek. This is a cheek/touch position. For ear/tilt position, while maintain the device aligned with the BM and FN lines, the device was pivot against ERP back for 15° or until the device antenna touch the phantom. Please refer to IEEE 1528-2003 illustration below.

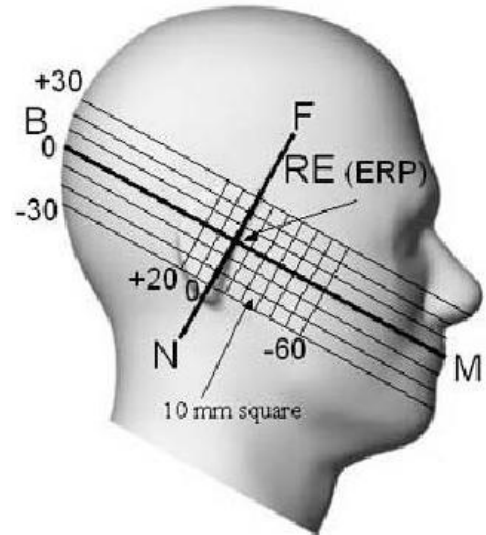

Figure 6.1 Side view of the phantom

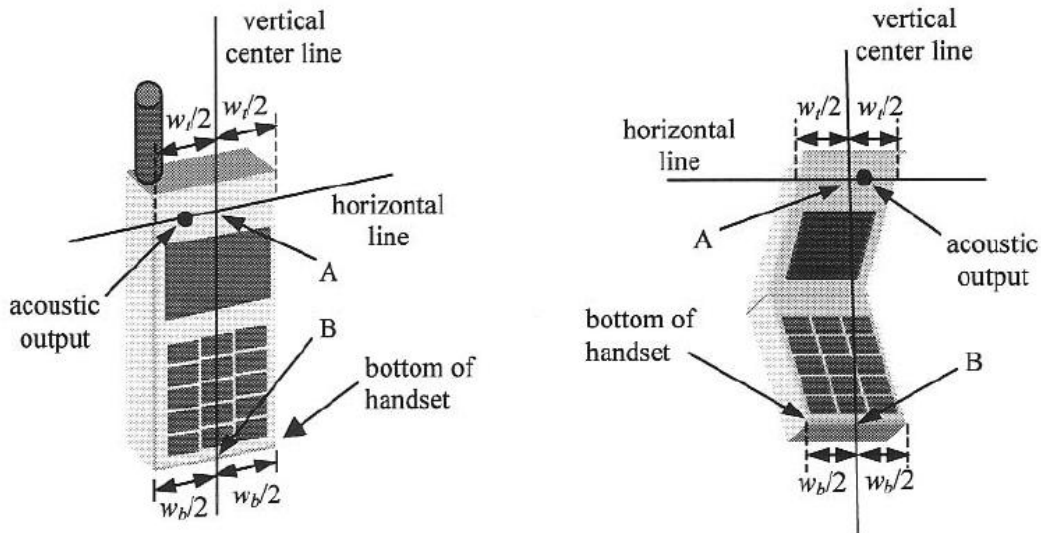

Figure 6.2 Handset vertical and horizontal reference lines



## **6.2 Body Holster/Belt Clip Configurations**

Body-worn operating configurations are tested with the belt-clips and holsters attached to the device and positioned against a flat phantom in a normal use configuration. A device with a headset output is tested with a headset connected to the device. Body dielectric parameters are used.

Accessories for Body-worn operation configurations are divided into two categories: those that do not contain metallic components and those that contain metallic components. When multiple accessories that do not contain metallic components are supplied with the device, the device is tested with only the accessory that dictates the closest spacing to the body. Then multiple accessories that contain metallic components are tested with each accessory. If multiple accessory share an identical metallic component (i.e. the same metallic belt-clip used with different holsters with no other metallic components) only the accessory that dictates the closest spacing to the body is tested.

Body-worn accessories may not always be supplied or available as options for some Devices intended to be authorized for body-worn use. In this case, a test configuration with a separation distance between the back of the device and the flat phantom is used.

Since this EUT does not supply any body worn accessory to the end user a distance of 1.5 cm from the EUT back surface to the liquid interface is configured for the generic test.

"See the Test SET-UP Photo"

Transmitters that are designed to operate in front of a person's face, as in push-to-talk configurations, are tested for SAR compliance with the front of the device positioned to face the flat phantom. For devices that are carried next to the body such as a shoulder, waist or chest-worn transmitters, SAR compliance is tested with the accessory(ies), including headsets and microphones, attached to the device and positioned against a flat phantom in a normal use configuration.

In all cases SAR measurements are performed to investigate the worst-case positioning. Worstcase positioning is then documented and used to perform Body SAR testing.

## 7. MEASUREMENT UNCERTAINTY

Error Description	Tol (± %)	Prob. dist.	Div.	$c_i$	Standard Uncertainty (± %)	$v_{eff}$
<b>1. Measurement System</b>						
Probe Calibration	6.00	N	1	1	6.00	$\infty$
Axial Isotropy	4.70	R	1.73	0.7	1.90	$\infty$
Hemispherical Isotropy	9.60	R	1.73	0.7	3.88	$\infty$
Boundary Effects	1.00	R	1.73	1	0.58	$\infty$
Linearity	4.70	R	1.73	1	2.71	$\infty$
System Detection Limits	1.00	R	1.73	1	0.58	$\infty$
Readout Electronics	0.30	N	1.00	1	0.30	$\infty$
Response Time	0.8	R	1.73	1	0.46	$\infty$
Integration Time	2.6	R	1.73	1	1.50	$\infty$
RF Ambient Conditions	3.00	R	1.73	1	1.73	$\infty$
Probe Positioner	0.40	R	1.73	1	0.23	$\infty$
Probe Positioning	2.90	R	1.73	1	1.67	$\infty$
Max SAR Eval	1.00	R	1.73	1	0.58	$\infty$
<b>2. Test Sample Related</b>						
Device Positioning	2.90	N	1.00	1	2.90	145
Device Holder	3.60	N	1.00	1	3.60	5
Power Drift	5.00	R	1.73	1	2.89	$\infty$
<b>3. Phantom and Setup</b>						
Phantom Uncertainty	4.00	R	1.73	1	2.31	$\infty$
Liquid Conductivity(target)	5.00	R	1.73	0.64	1.85	$\infty$
Liquid Conductivity(meas.)	2.07	N	1	0.64	1.32	9
Liquid Permittivity(target)	5.00	R	1.73	0.6	1.73	$\infty$
Liquid Permittivity(meas.)	5.02	N	1	0.6	3.01	9
<b>Combine Standard Uncertainty</b>					11.13	
<b>Coverage Factor for 95 %</b>					$k=2$	
<b>Expanded STD Uncertainty</b>					22.25	

Table 7.1 Uncertainty (800 MHz- 2450 MHz)

## 8. ANSI/ IEEE C95.1 - 1992 RF EXPOSURE LIMITS

HUMAN EXPOSURE	UNCONTROLLED ENVIRONMENT General Population (W/kg) or (mW/g)	CONTROLLED ENVIRONMENT Occupational (W/kg) or (mW/g)
SPATIAL PEAK SAR * (Brain)	1.60	8.00
SPATIAL AVERAGE SAR ** (Whole Body)	0.08	0.40
SPATIAL PEAK SAR *** (Hands / Feet / Ankle / Wrist)	4.00	20.00

**Table 8.1 Safety Limits for Partial Body Exposure**

**NOTES:**

\* The Spatial Peak value of the SAR averaged over any 1 g of tissue (defined as a tissue volume in the shape of a cube) and over the appropriate averaging time.

\*\* The Spatial Average value of the SAR averaged over the whole-body.

\*\*\* The Spatial Peak value of the SAR averaged over any 10 g of tissue (defined as a tissue volume in the shape of a cube) and over the appropriate averaging time.

**Uncontrolled Environments** are defined as locations where there is the exposure of individuals who have no knowledge or control of their exposure.

**Controlled Environments** are defined as locations where there is exposure that may be incurred by persons who are aware of the potential for exposure, (i.e.as a result of employment or occupation).

## 9. SAR SYSTEM VALIDATION

Per FCC KCB 865664 D02v01, SAR system validation status should be document to confirm measurement accuracy. The SAR systems (including SAR probes, system components and software versions) used for this device were validated against its performance specifications prior to the SAR measurements. Reference dipoles were used with the required tissue- equivalent media for system validation, according to the procedures outlined in IEEE 1528-2003 and FCC KDB 865664 D01 v01. Since SAR probe calibrations are frequency dependent, each probe calibration point was validated at a frequency within the valid frequency range of the probe calibration point, using the system that normally operates with the probe for routine SAR measurements and according to the required tissue-equivalent media.

A tabulated summary of the system validation status including the validation date(s), measurement frequencies, SAR probes and tissue dielectric parameters has been included.

SAR System #	Probe	probe Type	Probe Calibration Point		Dipole	Date	Dielectric Parameters		CW Validation			Modulation Validation		
							Measured Permittivity	Measured Conductivity	Sensitivity	Probe Linearity	Probe Isortopy	MOD. Type	Duty Factor	PAR
6	1798	ET3DV6	Head	835	441	May.06,2013	42.01	0.92	PASS	PASS	PASS	GMSK	PASS	N/A
6	1798	ET3DV6	Head	1900	5d032	May.07,2013	39.12	1.41	PASS	PASS	PASS	GMSK	PASS	N/A
6	1798	ET3DV6	Head	2450	743	May.08,2013	40.23	1.81	PASS	PASS	PASS	OFDM	N/A	PASS
6	1798	ET3DV6	Body	835	441	May.06,2013	55.88	0.99	PASS	PASS	PASS	GMSK	PASS	N/A
6	1798	ET3DV6	Body	1900	5d032	May.07,2013	54.67	1.54	PASS	PASS	PASS	GMSK	PASS	N/A
6	1798	ET3DV6	Body	2450	743	May.08,2013	52.77	1.97	PASS	PASS	PASS	OFDM	N/A	PASS

**Table 9.1 SAR System Validation Summary**

**Note;**

All measurement were performed using probes calibrated for CW signal only. Modulations in the table above represent test configurations for which the measurement system has been validated per FCC KDB Publication 865664 D01v01r01. SAR system were validated for modulated signals with a periodic duty cycle, such as GMSK, or with a high peak to average ratio (>5 dB), such as OFDM according to KDB 865664.

## 10. SYSTEM VERIFICATION

### 10.1 Tissue Verification

Freq. [MHz]	Date	Probe	Dipole	Liquid	Liquid Temp. [°C]	Parameters	Target Value	Measured Value	Deviation [%]	Limit [%]
835	Jun. 27, 2013	1798	441	Head	22.6	$\epsilon_r$	41.5	40.4	- 2.65	$\pm 5$
						$\sigma$	0.90	0.918	+ 2.00	$\pm 5$
835	Jun. 27, 2013		Body	22.6	$\epsilon_r$	55.2	56.9	+ 3.08	$\pm 5$	
					$\sigma$	0.97	0.982	+ 1.24	$\pm 5$	
1 900	Jun. 28, 2013		5d032	Head	22.7	$\epsilon_r$	40.0	39.7	- 0.75	$\pm 5$
						$\sigma$	1.40	1.41	+ 0.71	$\pm 5$
1 900	Jun. 28, 2013	Body	22.7	$\epsilon_r$	53.3	52.2	- 2.06	$\pm 5$		
				$\sigma$	1.52	1.55	+ 1.97	$\pm 5$		
2 450	Jun. 26, 2013	743	Head	22.4	$\epsilon_r$	39.2	39.4	+ 0.51	$\pm 5$	
					$\sigma$	1.80	1.81	+ 0.56	$\pm 5$	
2 450	Jun. 26, 2013	Body	22.4	$\epsilon_r$	52.7	53.7	+ 1.90	$\pm 5$		
				$\sigma$	1.95	1.94	- 0.51	$\pm 5$		

The Tissue dielectric parameters were measured prior to the SAR evaluation using an Agilent 85070C Dielectric Probe Kit and Agilent Network Analyzer.

### 10.2 System Verification

Prior to assessment, the system is verified to the  $\pm 10\%$  of the specifications at 835 MHz / 1 900 MHz / 2 450 MHz by using the system Verification kit. (Graphic Plots Attached)

Freq. [MHz]	Date	Probe (SN)	Dipole (SN)	Liquid	Amb. Temp. [°C]	Liquid Temp. [°C]	1 W Target SAR <sub>1g</sub> (SPEAG) (mW/g)	Measured SAR <sub>1g</sub> (mW/g)	1 W Normalized SAR <sub>1g</sub> (mW/g)	Deviation [%]	Limit [%]
835	Jun. 27, 2013	1798	441	Head	22.8	22.6	9.68	0.934	9.34	- 3.51	$\pm 10$
835	Jun. 27, 2013			Body	22.8	22.6	9.69	0.959	9.59	- 1.03	$\pm 10$
1 900	Jun. 28, 2013		5d032	Head	22.9	22.7	39.0	3.86	38.6	- 1.03	$\pm 10$
1 900	Jun. 28, 2013			Body	22.9	22.7	39.9	3.9	39	- 2.26	$\pm 10$
2 450	Jun. 26, 2013		743	Head	22.6	22.4	52.7	5.28	52.8	+ 0.19	$\pm 10$
2 450	Jun. 26, 2013			Body	22.6	22.4	51.2	5.19	51.9	+ 1.37	$\pm 10$

## **10.3 System Verification Procedure**

SAR measurement was prior to assessment, the system is verified to the  $\pm 10\%$  of the specifications at each frequency band by using the system Verification kit. (Graphic Plots Attached)

- Cabling the system, using the Verification kit equipments.
- Generate about 100 mW Input Level from the Signal generator to the Dipole Antenna.
- Dipole Antenna was placed below the Flat phantom.
- The measured one-gram SAR at the surface of the phantom above the dipole feed-point should be within 10 % of the target reference value.
- The results are normalized to 1 W input power.

## 11. RF CONDUCTED POWER MEASUREMENT

Power measurements were performed using a base station simulator under digital average power. The handset was placed into a simulated call using a base station simulator in a shielded chamber. Such test signals offer a consistent means for testing SAR and are recommended for evaluation SAR. SAR measurements were taken with a fully charged battery. In order to verify that the device was tested and maintained at full power, this was configured with the base station simulator. The SAR measurement Software calculates a reference point at the start and end of the test to check for power drifts. If conducted Power deviations of more than 5 % occurred, the tests were repeated.

### 11.1 Output Power Specifications.

This device operates using the following maximum output power specifications. SAR values were scaled to the maximum allowed power to determine compliance per KDB publication 447498 D01v05r01.

#### GSM

GSM850	GSM1900
Target Power : 33.2 dBm	Target Power : 29.7 dBm
GPRS850	PCS1900
GPRS 1tx : 33.2 dBm	GPRS 1tx : 29.7 dBm
GPRS 2tx : 31.2 dBm	GPRS 2tx : 27.7 dBm
GPRS 3tx : 29.2 dBm	GPRS 3tx : 25.7 dBm
GPRS 4tx : 27.2 dBm	GPRS 4tx : 23.7 dBm
Tune-up Tolerance : -1.5 dB/ +0.5 dB	

#### Wifi

Mode / Band		IEEE 802.11 (in dBm)			
		a	b	g	n
2.4 GHz WIFI			13.8	11.8	
5 GHz WIFI	UNII				
	DTS				
Tune-up Tolerance : -1.5 dB/ +0.7 dB					

#### BT

Target Power : 7.3 dBm

Power Tolerance : -1.5 dB/ +0.7 dB

## 11.2 GSM

Conducted output power measurements were performed using a base station simulator under digital average power.

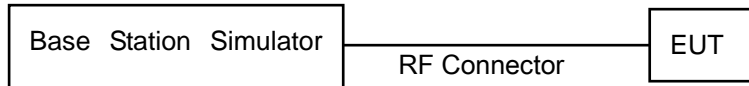

SAR Test for WWAN were performed with a base station simulator Agilent E5515C. Communication between the device and the emulator was established by air link. Set base station emulator to allow DUT to radiate maximum output power during all tests. Please refer to the below worst case SAR operation setup.

- GSM voice: Head SAR
- GPRS Multi-slots : Body SAR with GPRS Multi-slot Class12 with CS 1 (GMSK)

### **Note;**

CS1/MCS7 coding scheme was used in GPRS/EDGE output power measurements and SAR Testing, as a condition where GMSK/8PSK modulation was ensured. Investigation has shown that CS1 - CS4/ MCS5 – MCS9 settings do not have any impact on the output levels in the GPRS/EDGE modes.



Band	Channel	Voice	GPRS(GMSK) Data – CS1			
		GSM (dBm)	GPRS 1 TX Slot (dBm)	GPRS 2 TX Slot (dBm)	GPRS 3 TX Slot (dBm)	GPRS 4 TX Slot (dBm)
GSM 850	128	33.15	33.14	31.12	29.15	27.15
	190	33.17	33.15	31.14	29.15	27.15
	251	33.16	33.16	31.15	29.16	27.17
GSM 1900	512	29.59	29.59	27.51	25.53	23.55
	661	29.53	29.54	27.46	25.47	23.5
	810	29.54	29.54	27.45	25.46	23.5

GSM Conducted output powers (Burst-Average)

Band	Channel	Voice	GPRS(GMSK) Data – CS1			
		GSM (dBm)	GPRS 1 TX Slot (dBm)	GPRS 2 TX Slot (dBm)	GPRS 3 TX Slot (dBm)	GPRS 4 TX Slot (dBm)
GSM 850	128	24.12	24.11	25.1	24.89	24.14
	190	24.14	24.12	25.12	24.89	24.14
	251	24.13	24.13	25.13	24.9	24.16
GSM 1900	512	20.56	20.56	21.49	21.27	20.54
	661	20.5	20.51	21.44	21.21	20.49
	810	20.51	20.51	21.43	21.2	20.49

GSM Conducted output powers (Frame-Average)

**Note:**

Time slot average factor is as follows:

1 Tx slot = 9.03 dB, Frame-Average output power = Burst-Average output power – 9.03 dB

2 Tx slot = 6.02 dB, Frame-Average output power = Burst-Average output power – 6.02 dB

3 Tx slot = 4.26 dB, Frame-Average output power = Burst-Average output power – 4.26 dB

4 Tx slot = 3.01 dB, Frame-Average output power = Burst-Average output power – 3.01 dB

## 11.3 WiFi

### 11.3.1 SAR Testing for 802.11b/g modes

#### General Device Setup

Normal Network operating configurations are not suitable for measuring the SAR of 802.11 a/b/g transmitters. Unpredictable fluctuations in network traffic and antenna diversity conditions can introduce undesirable variations in SAR results. The SAR for these devices should be measured using chipset based test mode software to ensure the results are consistent and reliable.

Chipset based test mode software is hardware dependent and generally varies among manufacturers. The device operating parameters established in test mode for SAR measurements must be identical to those programmed in production units, including output power levels, amplifier gain settings and other RF performance tuning parameters. The test frequencies should correspond to actual channel frequencies defined for domestic use. SAR for devices with switched diversity should be measured with only one antenna transmitting at a time during each SAR measurement, according to a fixed modulation and data rate. The same data pattern should be used for all measurements.

#### Frequency Channel Configurations

802.11 a/b/g and 4.9 GHz operating modes are tested independently according to the service requirements in each frequency band. 802.11 b/g modes are tested on channels 1, 6 and 11. 802.11a is tested for UNII operations on channels 36 and 48 in the 5.15-5.25 GHz band; channels 52 and 64 in the 5.25-5.35 GHz band; Channels 104, 116, 124 and 136 in the 5.470-5.725 GHz band; and channels 149 and 161 in the 5.8 GHz band. When 5.8 GHz § 15.247 is also available, channels 149, 157 and 165 should be tested instead of the UNII channels. 4.9 GHz is tested on channels 1, 10 and 5 or 6, whichever has the higher output power, for 5 MHz channels; channels 11,15 and 19 for 10 MHz channels; and channels 21 and 25 for 20 MHz channels.

These are referred to as the "default test channels". 802.11g mode was evaluated only if the output power was 0.25 dB higher than the 802.11b mode.

Mode	GHz	Channel	Turbo Channel	"Default Test Channels"			
				§15.247		UNII	
				802.11b	802.11g		
802.11 b/g	2.412	1		√	∇		
	2.437	6	6	√	∇		
	2.462	11		√	∇		
802.11a	5.18	36				√	
	5.20	40	42 (5.21 GHz)			•	
	5.22	44				•	
	5.24	48	50 (5.25 GHz)			√	
	5.26	52				√	
	5.28	56	58 (5.29 GHz)			•	
	5.30	60				•	
	5.32	64			√		
	5.500	100	Unknown			•	
	5.520	104				√	
	5.540	108				•	
	5.560	112				•	
	5.580	116				√	
	5.600	120				•	
	5.620	124				√	
	5.640	128				•	
	5.660	132			•		
	5.680	136			√		
	5.700	140			•		
	UNII or §15.247	5.745	149		√		√
5.765		153	152 (5.76 GHz)			•	
5.785		157		√		•	
5.805		161	160 (5.80 GHz)			•	
§15.247	5.825	165		√		√	

802.11 Test Channels per FCC Requirements

**TEST RESULTS-Average**
**Conducted Output Power Measurements (802.11b Mode)**

802.11b Mode		Rate (Mbps)	Measured Power(dBm)	Duty Cycle Factor	Measured Power(dBm) + Duty Cycle Factor	Limit (dBm)
Frequency[MHz]	Channel No.					
2412	1	1 Mbps	14.06	0.197	14.26	30
		2 Mbps	14.08	0.403	14.49	30
		5.5 Mbps	14.25	0.187	14.44	30
		11 Mbps	14.05	0.359	14.41	30
2437	6	1 Mbps	13.88	0.197	14.07	30
		2 Mbps	13.96	0.403	14.36	30
		5.5 Mbps	14.29	0.187	14.47	30
		11 Mbps	13.90	0.359	14.26	30
2462	11	1 Mbps	14.00	0.197	14.19	30
		2 Mbps	14.08	0.403	14.49	30
		5.5 Mbps	14.16	0.187	14.35	30
		11 Mbps	14.00	0.359	14.36	30

**Conducted Output Power Measurements (802.11g Mode)**

802.11g Mode		Rate (Mbps)	Measured Power(dBm)	Duty Cycle Factor	Measured Power(dBm) + Duty Cycle Factor	Limit (dBm)
Frequency[MHz]	Channel No.					
2412	1	6 Mbps	12.18	0.226	12.40	30
		9 Mbps	11.88	0.333	12.21	30
		12 Mbps	11.88	0.437	12.32	30
		18 Mbps	11.59	0.633	12.22	30
		24 Mbps	11.21	0.828	12.04	30
		36 Mbps	10.94	1.151	12.09	30
		48 Mbps	10.75	1.452	12.20	30
		54 Mbps	10.60	1.596	12.20	30
2437	6	6 Mbps	11.92	0.226	12.15	30
		9 Mbps	11.80	0.333	12.14	30
		12 Mbps	11.41	0.437	11.85	30
		18 Mbps	11.31	0.633	11.95	30
		24 Mbps	11.06	0.828	11.89	30
		36 Mbps	10.33	1.151	11.48	30
		48 Mbps	10.44	1.452	11.89	30
		54 Mbps	10.27	1.596	11.86	30
2462	11	6 Mbps	11.86	0.226	12.08	30
		9 Mbps	11.79	0.333	12.12	30
		12 Mbps	11.78	0.437	12.22	30
		18 Mbps	11.58	0.633	12.21	30
		24 Mbps	11.22	0.828	12.05	30
		36 Mbps	10.93	1.151	12.08	30
		48 Mbps	10.70	1.452	12.15	30
		54 Mbps	10.61	1.596	12.21	30

Note;

SAR testing was performed according to the FCC KDB 248227.

## 11.4 SAR Test Exclusions Applied

### 11.4.1 BT

Per FCC KDB 447498 D01v05r01, The SAR exclusion threshold for distance < 50mm is defined by the following equation:

$$\frac{\text{Max Power of Channel (mW)}}{\text{Test Separation Distance (mm)}} * \sqrt{\text{Frequency (GHz)}} \leq 3.0$$

Mode	Frequency	Maximum Allowed Power	Separatuin Distance	≤ 3.0
	[MHz]	[mW]	[mm]	
Bluetooth	2441	6	10	0.99

Based on the maximum conducted power of Bluetooth and antenna to use separation distance, Bluetooth SAR was not required  $[(7/10) * \sqrt{2.441}] = 0.62 < 3.0$ .

This device contains transmitters that may operate simultaneously. Therefore simultaneous transmission analysis is required. Per FCC KDB 447498 D01v05r01 IV.C.1iii, simultaneous transmission SAR test exclusion may be applied when the sum of the 1-g SAR for all the simultaneous transmitting antennas in a specific a physical test configuration is ≤ 1.6W/kg. When standalone SAR is not required to be measured per FCC KDB 447498 D01v05r01 4.3.22, the following equation must be used to estimate the standalone 1-g SAR for simultaneous transmission assessment involving that transmitter

$$\text{Estimated SAR} = \frac{\sqrt{f(\text{GHz})}}{7.5} * \frac{(\text{Max Power of channel mW})}{\text{Min Separation Distance}}$$

Mode	Frequency	Maximum Allowed Power	Separatuin Distance (Body)	Estimated SAR (Body)
	[MHz]	[mW]	[mm]	[W/kg]
Bluetooth	2441	6	10	0.13

Note : Held-to ear configurations are not applicable to Bluetooth operations and therefore were not considered for simultaneous transmission. The Estimated SAR results were determined according to FCC KDB447498 D01v05r01

## 12. SAR Test configuration & Antenna Information

### 12.1 Antenna and Device Information

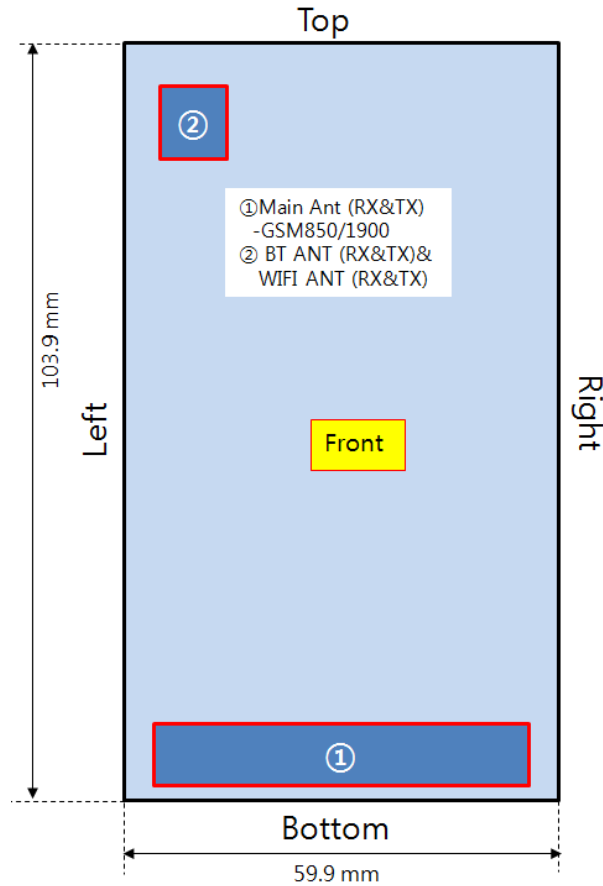

**[Front side View]**

- Please see LG-T585\_Ant\_distance file for further information.

## 13. SAR TEST DATA SUMMARY

### 13.1 Measurement Results (GSM 850 Head SAR)

Frequency		Modulation	Conducted Power (dBm)	Power Drift (dB)	Battery	Phantom Position	Measured SAR (mW/g)	Scaling Factor	Scaled SAR (mW/g)	Plot No.
MHz	Channel									
836.6	190	GSM850	33.17	-0.159	Standard	Left Ear	0.404	1.130	0.456	-
			33.17	-0.051	Standard	Left Tilt	0.186	1.130	0.210	-
			33.17	-0.139	Standard	Right Ear	0.416	1.130	<b>0.470</b>	1
			33.17	-0.004	Standard	Right Tilt	0.202	1.130	0.288	-
<b>ANSI/ IEEE C95.1 - 1992– Safety Limit Spatial Peak Uncontrolled Exposure/ General Population</b>						<b>Head 1.6 W/kg (mW/g)</b> Averaged over 1 gram				

**NOTES:**

- The test data reported are the worst-case SAR value with the antenna-head position set in a typical configuration. Test procedures used are according to FCC/OET Bulletin 65, Supplement C [July 2001].
- All modes of operation were investigated and the worst-case are reported.
- Measured Depth of Simulating Tissue is 15.0 cm ± 0.2 cm.
- Tissue parameters and temperatures are listed on the SAR plot.
- Battery Type  Standard  Extended  Slim  
Batteries are fully charged for all readings.
- Test Signal Call Mode  Manual Test cord  Base Station Simulator
- According to KDB 447498, Testing of other required channels within the operating mode of a frequency band is not required when the reported 1-g or 10-g SAR for the mid-band or highest output power channel is ≤ 0.8 W/kg or 2.0 W/kg, for 1-g or 10-g respectively, when the transmission band is ≤ 100 MHz.

## 13.2 Measurement Results (GSM 1 900 Head SAR)

Frequency		Modulation	Conducted Power (dBm)	Power Drift (dB)	Battery	Phantom Position	Measured SAR (mW/g)	Scaling Factor	Scaled SAR (mW/g)	Plot No.
MHz	Channel									
1850.2	512	GSM1900	29.59	-0.058	Standard	Left Ear	0.797	1.151	0.917	-
1880.0	661		29.53	0.128	Standard	Left Ear	0.834	1.167	<b>0.973</b>	2
1909.8	810		29.54	-0.007	Standard	Left Ear	0.809	1.164	0.942	-
1880.0	661		29.53	-0.017	Standard	Left Tilt	0.217	1.167	0.253	-
			29.53	-0.036	Standard	Right Ear	0.523	1.167	0.610	-
			29.53	-0.007	Standard	Right Tilt	0.37	1.167	0.432	-
<b>ANSI/ IEEE C95.1 - 1992– Safety Limit</b> <b>Spatial Peak</b> <b>Uncontrolled Exposure/ General Population</b>						<b>Head</b> <b>1.6 W/kg (mW/g)</b> <small>Averaged over 1 gram</small>				

**NOTES:**

- The test data reported are the worst-case SAR value with the antenna-head position set in a typical configuration. Test procedures used are according to FCC/OET Bulletin 65, Supplement C [July 2001].
- All modes of operation were investigated and the worst-case are reported.
- Measured Depth of Simulating Tissue is 15.0 cm ± 0.2 cm.
- Tissue parameters and temperatures are listed on the SAR plot.
- Battery Type  Standard  Extended  Slim  
Batteries are fully charged for all readings.
- Test Signal Call Mode  Manual Test cord  Base Station Simulator
- According to KDB 447498, Testing of other required channels within the operating mode of a frequency band is not required when the reported 1-g or 10-g SAR for the mid-band or highest output power channel is ≤ 0.8 W/kg or 2.0 W/kg, for 1-g or 10-g respectively, when the transmission band is ≤ 100 MHz.

### 13.3 Measurement Results (802.11b/g Head SAR)

Frequency		Modulation	Conducted Power (dBm)	Power Drift (dB)	Battery	Phantom Position	Data Rate	Measured SAR (mW/g)	Scaling Factor	Scaled SAR (mW/g)	Plot No.
MHz	Channel										
2412	1	802.11b	14.26	0.114	Standard	Left Ear	1Mbps	0.165	1.057	0.174	-
			14.26	0.032	Standard	Left Tilt	1Mbps	0.087	1.057	0.092	-
			14.26	0.088	Standard	Right Ear	1Mbps	0.449	1.057	<b>0.475</b>	3
			14.26	0.076	Standard	Right Tilt	1Mbps	0.252	1.057	0.266	-
<b>ANSI/ IEEE C95.1 - 1992– Safety Limit Spatial Peak Uncontrolled Exposure/ General Population</b>						<b>Head 1.6 W/kg (mW/g) Averaged over 1 gram</b>					

**NOTES:**

- 1 The test data reported are the worst-case SAR value with the antenna-head position set in a typical configuration. Test procedures used are according to FCC/OET Bulletin 65, Supplement C [July 2001].
- 2 All modes of operation were investigated and the worst-case are reported.
- 3 Measured Depth of Simulating Tissue is 15.0 cm ± 0.2 cm.
- 4 Tissue parameters and temperatures are listed on the SAR plot.
- 5 Battery Type  Standard  Extended  Slim  
Batteries are fully charged for all readings.
- 6 Test Signal Call Mode  Manual Test cord  Base Station Simulator
- 7 IEEE 802.11g(including 802.11n) SAR testing is required when the conducted powers are equal to or greater than 0.25 dB Than the conducted powers in IEEE 802.11b.
- 8 For 2.4GHz WLAN, Highest average power channel for the lowest data rate was selected for SAR evaluation based on KDB 248227. Other channels are not necessary because 1g-average SAR < 0.8 W/Kg and peak SAR < 1.6W/Kg per KDB 248227.



## 13.4 Measurement Results (Body-worn SAR)

Frequency		Modulation	Conducted Power (dBm)	Power Drift (dB)	Configuration	Separation Distance	Measured SAR (mW/g)	Scaling Factor	Scaled SAR (mW/g)	Plot No.
MHz	Channel									
836.6	190	GSM 850	33.17	-0.080	Rear	1.5 cm	0.444	1.130	<b>0.502</b>	4
836.6	190	GSM 850	33.17	0.016	Front	1.5 cm	0.240	1.130	0.271	
1 880	661	GSM 1900	29.53	-0.041	Rear	1.5 cm	0.220	1.167	<b>0.257</b>	5
1 880	661	GSM 1900	29.53	-0.003	Front	1.5 cm	0.198	1.167	0.231	
2 412	1	802.11b (1 Mbps)	14.26	0.182	Rear	1.5 cm	0.062	1.057	<b>0.066</b>	6
2 412	1	802.11b (1 Mbps)	14.26	-0.079	Front	1.5 cm	0.037	1.057	0.039	
<b>ANSI/ IEEE C95.1 - 1992– Safety Limit Spatial Peak Uncontrolled Exposure/ General Population</b>						<b>Body 1.6 W/kg (mW/g) Averaged over 1 gram</b>				

### NOTES:

- 1 The test data reported are the worst-case SAR value with the antenna-body position set in a typical configuration. Test procedures used are according to FCC/OET Bulletin 65, Supplement C [July 2001].
- 2 All modes of operation were investigated and the worst-case are reported.
- 3 Measured Depth of Simulating Tissue is 15.0 cm ± 0.2 cm.
- 4 Tissue parameters and temperatures are listed on the SAR plot.
- 5 According to KDB 447498, Testing of other required channels within the operating mode of a frequency band is not required when the reported 1-g or 10-g SAR for the mid-band or highest output power channel is ≤ 0.8 W/kg or 2.0 W/kg, for 1-g or 10-g respectively, when the transmission band is ≤ 100 MHz.
- 6 Body-Worn accessory testing is typically associated with voice operation. Therefore, GSM voice was evaluated for body-worn SAR.

## 14. SAR Measurement Variability and Uncertainty

In accordance with published RF Exposure KDB procedure 865664 D01 SAR measurement 100 MHz to 6 GHz v01.

These additional measurements are repeated after the completion of all measurements requiring the same head or body tissue-equivalent medium in a frequency band. The test device should be returned to ambient conditions (normal room temperature) with the battery fully charged before it is re-mounted on the device holder for the repeated measurement(s) to minimize any unexpected variations in the repeated results.

- 1) Repeated measurement is not required when the original highest measured SAR is < 0.80 W/kg; steps 2) through 4) do not apply.
- 2) When the original highest measured SAR is  $\geq 0.80$  W/kg, repeat that measurement once.
- 3) Perform a second repeated measurement only if the ratio of largest to smallest SAR for the original and first repeated measurements is > 1.20 or when the original or repeated measurement is  $\geq 1.45$  W/kg (~ 10% from the 1-g SAR limit).
- 4) Perform a third repeated measurement only if the original, first or second repeated measurement is  $\geq 1.5$  W/kg and the ratio of largest to smallest SAR for the original, first and second repeated measurements is > 1.20.

Frequency		Modulation	Battery	Phantom Position	Original SAR(mW/g)	Repeated SAR(mW/g)	Largest to Smallest SAR Ratio	Plot No.
MHz	Channel							
1 880.0	661 (Mid)	GSM1900	Standard	Left Ear	0.834	0.800	1.04	7

**Note(s):**

1. Second Repeated Measurement is not required since the ratio of the largest to smallest SAR for the original and first repeated measurement is not > 1.20.
2. Repeated measurement is not required when the original highest measured SAR is < 0.80 W/kg.

## 15. SAR Summation Scenario

	Position	Applicable Combination
Simultaneous Transmission	Head	GSM 850 Voice + 2.4 GHz WiFi
		GSM 1 900 Voice + 2.4 GHz WiFi
	Body-worn	GSM 850 Voice + 2.4 GHz WiFi
		GSM 1900 Voice + 2.4 GHz WiFi
		GSM 850 Voice + 2.4 GHz Bluetooth
		GSM 1900 Voice + 2.4 GHz Bluetooth
BT and WLAN are not simultaneous transmission.		

## 15.1 Simultaneous Transmission Summation for Head

### Simultaneous Transmission Summation for Held to Ear

Band	configuration	Scaled SAR(W/kg)	2.4 GHz WIFI Scaled SAR (W/kg)	$\Sigma$ 1-g SAR (W/kg)
GSM 850	Left Cheek	0.456	0.174	0.63
	Left Tilt	0.210	0.092	0.302
	Right Cheek	0.470	<b>0.475</b>	0.945
	Right Tilt	0.288	0.266	0.554
GSM 1 900	Left Cheek	0.973	0.174	1.147
	Left Tilt	0.253	0.092	0.345
	Right Cheek	0.610	<b>0.475</b>	1.085
	Right Tilt	0.432	0.266	0.698

## 15.2 Simultaneous Transmission Summation for Body-Worn

Band	configuration	Scaled SAR(W/kg)	2.4 GHz WIFI Scaled SAR (W/kg)	$\Sigma$ 1-g SAR (W/kg)
GSM 850	Rear	0.502	0.066	0.568
GSM 1900	Rear	0.257	0.066	0.323

Band	configuration	Scaled SAR(W/kg)	BT SAR	$\Sigma$ 1-g SAR
			(W/kg)	(W/kg)
GSM 850	Rear	0.502	0.13	0.632
GSM 1900	Rear	0.257	0.13	0.387

## **16. CONCLUSION**

---

The SAR measurement indicates that the EUT complies with the RF radiation exposure limits of the ANSI/IEEE C95.1 1992.

These measurements are taken to simulate the RF effects exposure under worst-case conditions. Precise laboratory measures were taken to assure repeatability of the tests

## 17. REFERENCES

---

- [1] Federal Communications Commission, OET Bulletin 65 (Edition 97-01), Supplement C (Edition 01-01), Evaluating Compliance with FCC Guidelines for Human Exposure to Radio frequency Electromagnetic Fields, July 2001.
- [2] IEEE Standards Coordinating Committee 34 – IEEE Std. 1528-2003, IEEE Recommended Practice for Determining the Peak Spatial-Average Specific Absorption Rate (SAR) in the Human Body from Wireless Communications Devices.
- [3] Federal Communications Commission, ET Docket 93-62, Guidelines for Evaluating the Environmental Effects of Radio frequency Radiation, Aug. 1996.
- [4] ANSI/IEEE C95.1 - 1991, American National Standard safety levels with respect to human exposure to radio frequency electromagnetic fields, 300 kHz to 100 GHz, New York: IEEE, Aug. 1992
- [5] ANSI/IEEE C95.3 - 1991, IEEE Recommended Practice for the Measurement of Potentially Hazardous Electromagnetic Fields - RF and Microwave, New York: IEEE, 1992.
- [6] NCRP, National Council on Radiation Protection and Measurements, Biological Effects and Exposure Criteria for Radio Frequency Electromagnetic Fields, NCRP Report No. 86, 1986. Reprinted Feb. 1995.
- [7] T. Schmid, O. Egger, N. Kuster, Automated E-field scanning system for dosimetric assessments, IEEE Transaction on Microwave Theory and Techniques, vol. 44, Jan. 1996, pp. 105-113.
- [8] K. Pokovic, T. Schmid, N. Kuster, Robust setup for precise calibration of E-field probes in tissue simulating liquids at mobile communications frequencies, ICECOM97, Oct. 1997, pp. 120-124.
- [9] K. Pokovic, T. Schmid, and N. Kuster, E-field Probe with improved isotropy in brain simulating liquids, Proceedings of the ELMAR, Zadar, Croatia, June 23-25, 1996, pp. 172-175.
- [10] Schmid & Partner Engineering AG, Application Note: Data Storage and Evaluation, June 1998, p2.
- [11] V. Hombach, K. Meier, M. Burkhardt, E. Kuhn, N. Kuster, The Dependence of EM Energy Absorption upon Human Head Modeling at 900 MHz, IEEE Transaction on Microwave Theory and Techniques, vol. 44 no. 10, Oct. 1996, pp. 1865-1873.
- [12] N. Kuster and Q. Balzano, Energy absorption mechanism by biological bodies in the near field of dipole antennas above 300 MHz, IEEE Transaction on Vehicular Technology, vol. 41, no. 1, Feb. 1992, pp. 17-23.
- [13] G. Hartsgrove, A. Kraszewski, A. Surowiec, Simulated Biological Materials for Electromagnetic Radiation Absorption Studies, University of Ottawa, Bioelectromagnetics, Canada: 1987, pp. 29-36.
- [14] Q. Balzano, O. Garay, T. Manning Jr., Electromagnetic Energy Exposure of Simulated Users of Portable Cellular Telephones, IEEE Transactions on Vehicular Technology, vol. 44, no.3, Aug. 1995.
- [15] W. Gander, Computer mathematic, Birkhaeuser, Basel, 1992.
- [16] W.H. Press, S.A. Teukolsky, W.T. Vetterling, and B.P. Flannery, Numerical Recipes in C, The Art of Scientific Computing, Second edition, Cambridge University Press, 1992.
- [17] Federal Communications Commission, OET Bulletin 65, Evaluating Compliance with FCC Guidelines for Human Exposure to Radiofrequency Electromagnetic Fields. Supplement C, Dec. 1997.
- [18] N. Kuster, R. Kastle, T. Schmid, Dosimetric evaluation of mobile communications equipment with known precision, IEEE Transaction on Communications, vol. E80-B, no. 5, May 1997, pp. 645-652.
- [19] CENELEC CLC/SC111B, European Prestandard (prENV 50166-2), Human Exposure to Electromagnetic Fields High-frequency: 10 kHz-300 GHz, Jan. 1995.
- [20] Prof. Dr. Niels Kuster, ETH, Eidgenössische Technische Hochschule Zürich, Dosimetric Evaluation of the Cellular Phone.
- [21] SAR Evaluation of Handsets with Multiple Transmitters and Antennas #648474.
- [22] SAR Measurement Procedure for 802.11 a/b/g Transmitters #KDB 248227.

## Attachment 1. – SAR Test Plots



Test Laboratory: HCT CO., LTD  
EUT Type: Cellular/PCS GSM/GPRS/EDGE(RX Only) Phone with Bluetooth, WLAN.  
Liquid Temperature: 22.6 °C  
Ambient Temperature: 22.8 °C  
Test Date: Jun . 27, 2013  
Plot NO. 1

**DUT: LG-P585; Type: bar; Serial: #1**

Communication System: GSM 850; Frequency: 836.6 MHz; Duty Cycle: 1:8.3  
Medium parameters used (interpolated):  $f = 836.6$  MHz;  $\sigma = 0.92$  mho/m;  $\epsilon_r = 40.4$ ;  $\rho = 1000$  kg/m<sup>3</sup>  
Phantom section: Right Section ; Measurement SW: DASY4, V4.7 Build 80; Postprocessing SW: SEMCAD, V1.8 Build 184

## DASY4 Configuration:

- Probe: ET3DV6 - SN1798; ConvF(6.64, 6.64, 6.64); Calibrated: 2013-04-29
- Sensor-Surface: 4mm (Mechanical Surface Detection)
- Electronics: DAE3 Sn466; Calibrated: 2013-02-21
- Phantom: SAM 835/900 MHz; Type: SAM

**GSM850 Right touch 190ch/Area Scan (61x91x1):** Measurement grid: dx=15mm, dy=15mm

Info: [Interpolated medium parameters used for SAR evaluation.](#)

Maximum value of SAR (interpolated) = 0.469 mW/g

**GSM850 Right touch 190ch/Zoom Scan (5x5x7)/Cube 0:** Measurement grid:

dx=8mm, dy=8mm, dz=5mm

Reference Value = 7.19 V/m; Power Drift = -0.139 dB

Peak SAR (extrapolated) = 0.534 W/kg

**SAR(1 g) = 0.416 mW/g; SAR(10 g) = 0.300 mW/g**

Info: [Interpolated medium parameters used for SAR evaluation.](#)

Maximum value of SAR (measured) = 0.443 mW/g

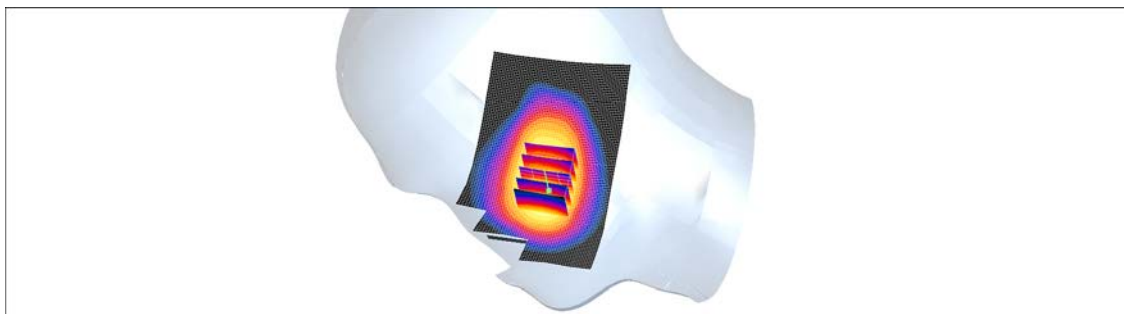
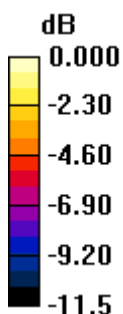

0 dB = 0.443mW/g

Test Laboratory: HCT CO., LTD  
 EUT Type: Cellular/PCS GSM/GPRS/EDGE(RX Only) Phone with Bluetooth, WLAN.  
 Liquid Temperature: 22.7 °C  
 Ambient Temperature: 22.9 °C  
 Test Date: Jun . 28, 2013  
 Plot NO. 2

**DUT: LG-T585; Type: bar; Serial: #1**

Communication System: GSM 1900; Frequency: 1880 MHz;Duty Cycle: 1:8.3  
 Medium parameters used:  $f = 1880 \text{ MHz}$ ;  $\sigma = 1.39 \text{ mho/m}$ ;  $\epsilon_r = 39.8$ ;  $\rho = 1000 \text{ kg/m}^3$   
 Phantom section: Left Section ; Measurement SW: DASY4, V4.7 Build 80; Postprocessing SW: SEMCAD, V1.8 Build 184

DASY4 Configuration:

- Probe: ET3DV6 - SN1798; ConvF(5.29, 5.29, 5.29); Calibrated: 2013-04-29
- Sensor-Surface: 4mm (Mechanical Surface Detection)
- Electronics: DAE3 Sn466; Calibrated: 2013-02-21
- Phantom: SAM 1800/1900 MHz; Type: SAM

**GSM1900 Left Touch 661ch/Area Scan (61x91x1):** Measurement grid: dx=15mm, dy=15mm

Maximum value of SAR (interpolated) = 1.00 mW/g

**GSM1900 Left Touch 661ch/Zoom Scan (5x5x7)/Cube 0:** Measurement grid:

dx=8mm, dy=8mm, dz=5mm  
 Reference Value = 6.58 V/m; Power Drift = 0.128 dB  
 Peak SAR (extrapolated) = 1.23 W/kg  
**SAR(1 g) = 0.834 mW/g; SAR(10 g) = 0.505 mW/g**  
 Maximum value of SAR (measured) = 0.926 mW/g

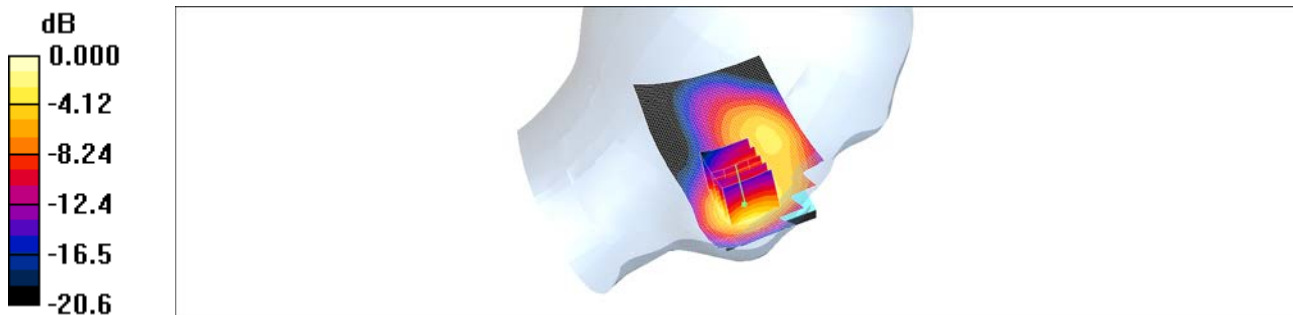

0 dB = 0.926mW/g

Test Laboratory: HCT CO., LTD  
 EUT Type: Cellular/PCS GSM/GPRS/EDGE(RX Only) Phone with Bluetooth, WLAN.  
 Liquid Temperature: 22.4 °C  
 Ambient Temperature: 22.6 °C  
 Test Date: Jun . 26, 2013  
 Plot NO. 3

**DUT: LG-T585; Type: bar; Serial: #1**

Communication System: 2450MHz FCC; Frequency: 2412 MHz;Duty Cycle: 1:1  
 Medium parameters used (interpolated):  $f = 2412 \text{ MHz}$ ;  $\sigma = 1.77 \text{ mho/m}$ ;  $\epsilon_r = 39.5$ ;  $\rho = 1000 \text{ kg/m}^3$   
 Phantom section: Right Section ; Measurement SW: DASY4, V4.7 Build 80; Postprocessing SW: SEMCAD, V1.8 Build 184

DASY4 Configuration:

- Probe: ET3DV6 - SN1798; ConvF(4.63, 4.63, 4.63); Calibrated: 2013-04-29
- Sensor-Surface: 4mm (Mechanical Surface Detection)
- Electronics: DAE3 Sn466; Calibrated: 2013-02-21
- Phantom: 835/900 Phantom ; Type: SAM

**WiFi2450 Right touch 1ch/Area Scan (71x111x1):** Measurement grid: dx=12mm, dy=12mm

Info: [Interpolated medium parameters used for SAR evaluation.](#)

Maximum value of SAR (interpolated) = 0.480 mW/g

**WiFi2450 Right touch 1ch/Zoom Scan (7x7x7)/Cube 0:** Measurement grid: dx=5mm, dy=5mm, dz=5mm

Reference Value = 7.84 V/m; Power Drift = 0.088 dB

Peak SAR (extrapolated) = 1.04 W/kg

SAR(1 g) = 0.449 mW/g; SAR(10 g) = 0.206 mW/g

Info: [Interpolated medium parameters used for SAR evaluation.](#)

Maximum value of SAR (measured) = 0.526 mW/g

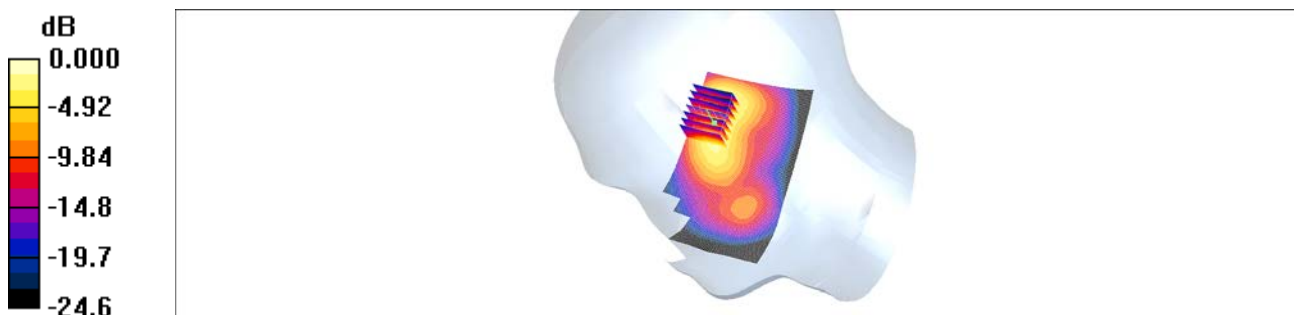

0 dB = 0.526mW/g

Test Laboratory: HCT CO., LTD  
EUT Type: Cellular/PCS GSM/GPRS/EDGE(RX Only) Phone with Bluetooth, WLAN.  
Liquid Temperature: 22.6 °C  
Ambient Temperature: 22.8 °C  
Test Date: Jun . 27, 2013  
Plot NO. 4

**DUT: LG-T585; Type: bar; Serial: #1**

Communication System: GSM 850; Frequency: 836.6 MHz; Duty Cycle: 1:8.3  
Medium parameters used (interpolated):  $f = 836.6$  MHz;  $\sigma = 0.983$  mho/m;  $\epsilon_r = 56.9$ ;  $\rho = 1000$  kg/m<sup>3</sup>  
Phantom section: Center Section ; Measurement SW: DASY4, V4.7 Build 80; Postprocessing SW: SEMCAD, V1.8 Build 184

## DASY4 Configuration:

- Probe: ET3DV6 - SN1798; ConvF(6.46, 6.46, 6.46); Calibrated: 2013-04-29
- Sensor-Surface: 4mm (Mechanical Surface Detection)
- Electronics: DAE3 Sn466; Calibrated: 2013-02-21
- Phantom: Triple Flat Phantom 5.1C; Type: QD 000 P51 CA

**GSM850 Body rear 190ch/Area Scan (61x91x1):** Measurement grid: dx=15mm, dy=15mm

Info: [Interpolated medium parameters used for SAR evaluation.](#)

Maximum value of SAR (interpolated) = 0.472 mW/g

**GSM850 Body rear 190ch/Zoom Scan (5x5x7)/Cube 0:** Measurement grid: dx=8mm, dy=8mm, dz=5mm

Reference Value = 10.2 V/m; Power Drift = -0.080 dB

Peak SAR (extrapolated) = 0.562 W/kg

**SAR(1 g) = 0.444 mW/g; SAR(10 g) = 0.322 mW/g**

Info: [Interpolated medium parameters used for SAR evaluation.](#)

Maximum value of SAR (measured) = 0.473 mW/g

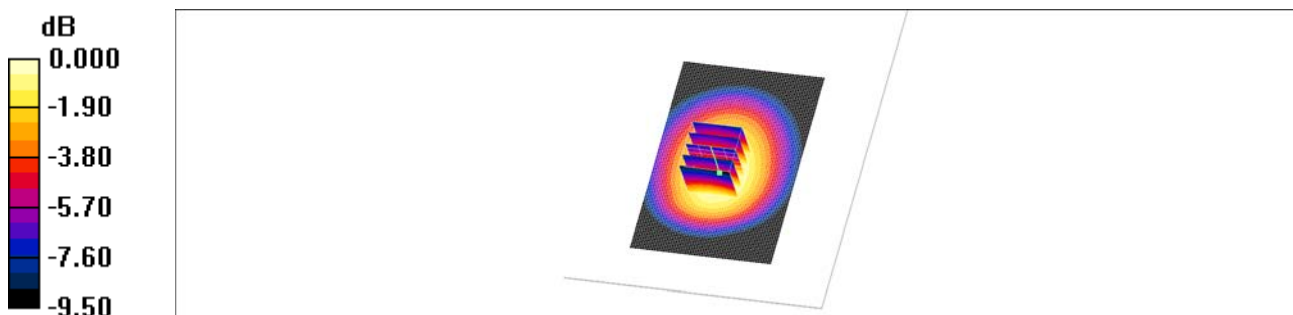

0 dB = 0.473mW/g

Test Laboratory: HCT CO., LTD  
EUT Type: Cellular/PCS GSM/GPRS/EDGE(RX Only) Phone with Bluetooth, WLAN.  
Liquid Temperature: 22.7 °C  
Ambient Temperature: 22.9 °C  
Test Date: Jun . 28, 2013  
Plot NO. 5

**DUT: LG-T585; Type: bar; Serial: #1**

Communication System: GSM 1900; Frequency: 1880 MHz; Duty Cycle: 1:8.3  
Medium parameters used:  $f = 1880$  MHz;  $\sigma = 1.53$  mho/m;  $\epsilon_r = 52.2$ ;  $\rho = 1000$  kg/m<sup>3</sup>  
Phantom section: Center Section ; Measurement SW: DASY4, V4.7 Build 80; Postprocessing SW: SEMCAD, V1.8 Build 184

## DASY4 Configuration:

- Probe: ET3DV6 - SN1798; ConvF(4.7, 4.7, 4.7); Calibrated: 2013-04-29
- Sensor-Surface: 4mm (Mechanical Surface Detection)
- Electronics: DAE3 Sn466; Calibrated: 2013-02-21
- Phantom: Triple Flat Phantom 5.1C; Type: QD 000 P51 CA

**GSM1900 Body rear 661ch/Area Scan (61x91x1):** Measurement grid: dx=15mm, dy=15mm

Maximum value of SAR (interpolated) = 0.240 mW/g

**GSM1900 Body rear 661ch/Zoom Scan (5x5x7)/Cube 0:** Measurement grid:

dx=8mm, dy=8mm, dz=5mm

Reference Value = 10.4 V/m; Power Drift = -0.041 dB

Peak SAR (extrapolated) = 0.306 W/kg

**SAR(1 g) = 0.220 mW/g; SAR(10 g) = 0.145 mW/g**

Maximum value of SAR (measured) = 0.237 mW/g

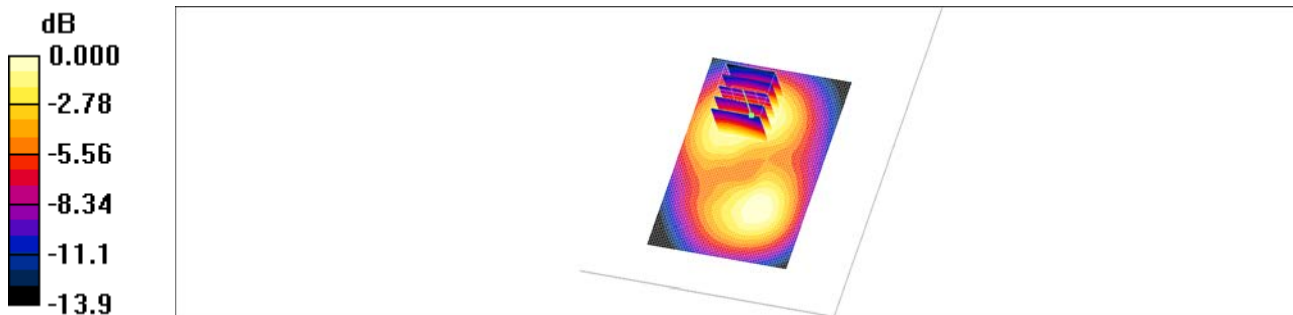

0 dB = 0.237mW/g

Test Laboratory: HCT CO., LTD  
EUT Type: Cellular/PCS GSM/GPRS/EDGE(RX Only) Phone with Bluetooth, WLAN.  
Liquid Temperature: 22.4 °C  
Ambient Temperature: 22.6 °C  
Test Date: Jun . 26, 2013  
Plot NO. 6

**DUT: LG-P585; Type: bar; Serial: #1**

Communication System: 2450MHz FCC; Frequency: 2412 MHz;Duty Cycle: 1:1  
Medium parameters used (interpolated):  $f = 2412$  MHz;  $\sigma = 1.89$  mho/m;  $\epsilon_r = 53.8$ ;  $\rho = 1000$  kg/m<sup>3</sup>  
Phantom section: Center Section ; Measurement SW: DASY4, V4.7 Build 80; Postprocessing SW: SEMCAD, V1.8 Build 186

## DASY4 Configuration:

- Probe: ET3DV6 - SN1798; ConvF(4.16, 4.16, 4.16); Calibrated: 2013-04-29
- Sensor-Surface: 4mm (Mechanical Surface Detection)
- Electronics: DAE3 Sn466; Calibrated: 2013-02-21
- Phantom: Triple Flat Phantom 5.1C; Type: QD 000 P51 CA

**WiFi2450 Body rear 1ch/Area Scan (71x111x1):** Measurement grid: dx=12mm, dy=12mm

Info: [Interpolated medium parameters used for SAR evaluation.](#)

Maximum value of SAR (interpolated) = 0.068 mW/g

**WiFi2450 Body rear 1ch/Zoom Scan (7x7x7)/Cube 0:** Measurement grid: dx=5mm, dy=5mm, dz=5mm

Reference Value = 3.56 V/m; Power Drift = 0.182 dB

Peak SAR (extrapolated) = 0.158 W/kg

**SAR(1 g) = 0.062 mW/g; SAR(10 g) = 0.029 mW/g**

Info: [Interpolated medium parameters used for SAR evaluation.](#)

Maximum value of SAR (measured) = 0.067 mW/g

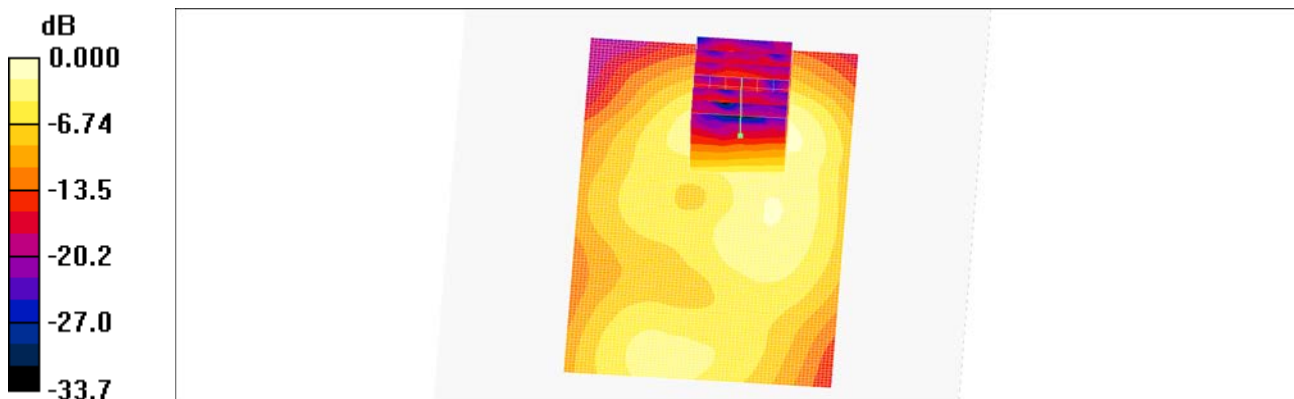

Test Laboratory: HCT CO., LTD  
 EUT Type: Cellular/PCS GSM/GPRS/EDGE(RX Only) Phone with Bluetooth, WLAN.  
 Liquid Temperature: 22.7 °C  
 Ambient Temperature: 22.9 °C  
 Test Date: Jun . 28, 2013  
 Plot NO. 7

**DUT: LG-P585; Type: bar; Serial: #1**

Communication System: GSM 1900; Frequency: 1880 MHz;Duty Cycle: 1:8.3  
 Medium parameters used:  $f = 1880 \text{ MHz}$ ;  $\sigma = 1.39 \text{ mho/m}$ ;  $\epsilon_r = 39.8$ ;  $\rho = 1000 \text{ kg/m}^3$   
 Phantom section: Left Section ; Measurement SW: DASY4, V4.7 Build 80; Postprocessing SW: SEMCAD, V1.8 Build 184

DASY4 Configuration:

- Probe: ET3DV6 - SN1798; ConvF(5.29, 5.29, 5.29); Calibrated: 2013-04-29
- Sensor-Surface: 4mm (Mechanical Surface Detection)
- Electronics: DAE3 Sn466; Calibrated: 2013-02-21
- Phantom: SAM 1800/1900 MHz; Type: SAM

**GSM1900 Left Touch 661ch/Area Scan (61x91x1):** Measurement grid: dx=15mm, dy=15mm

Maximum value of SAR (interpolated) = 0.895 mW/g

**GSM1900 Left Touch 661ch/Zoom Scan (5x5x7)/Cube 0:** Measurement grid:

dx=8mm, dy=8mm, dz=5mm  
 Reference Value = 10.1 V/m; Power Drift = 0.016 dB  
 Peak SAR (extrapolated) = 1.13 W/kg  
**SAR(1 g) = 0.800 mW/g; SAR(10 g) = 0.499 mW/g**  
 Maximum value of SAR (measured) = 0.876 mW/g

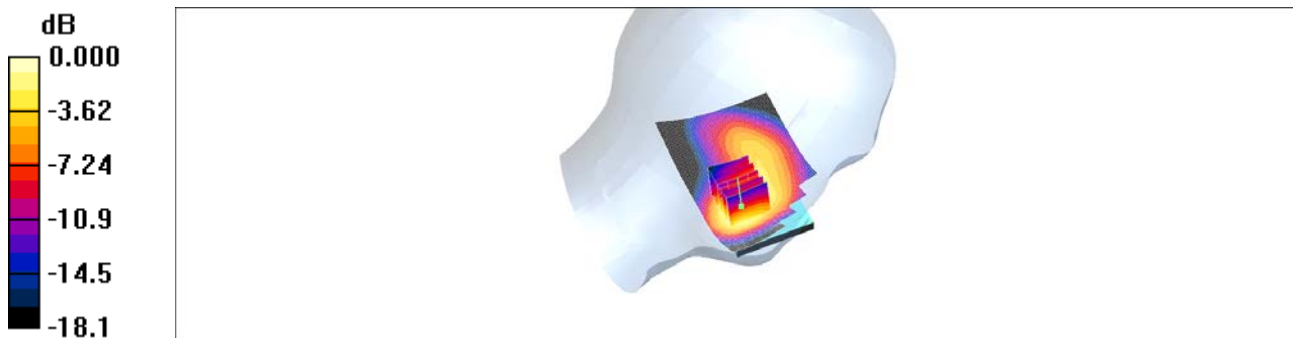

0 dB = 0.876mW/g

Test Laboratory: HCT CO., LTD  
 EUT Type: Cellular/PCS GSM/GPRS/EDGE(RX Only) Phone with Bluetooth, WLAN.  
 Liquid Temperature: 22.6 °C  
 Ambient Temperature: 22.8 °C  
 Test Date: Jun . 27, 2013  
 Plot NO. 8

Communication System: GSM 850; Frequency: 836.6 MHz; Duty Cycle: 1:8.3  
 Medium parameters used (interpolated):  $f = 836.6$  MHz;  $\sigma = 0.92$  mho/m;  $\epsilon_r = 40.4$ ;  $\rho = 1000$  kg/m<sup>3</sup>  
 Phantom section: Right Section ; Measurement SW: DASY4, V4.7 Build 80; Postprocessing SW: SEMCAD, V1.8 Build 184

DASY4 Configuration:

- Probe: ET3DV6 - SN1798; ConvF(6.64, 6.64, 6.64); Calibrated: 2013-04-29
- Sensor-Surface: 4mm (Mechanical Surface Detection)
- Electronics: DAE3 Sn466; Calibrated: 2013-02-21
- Phantom: SAM 835/900 MHz; Type: SAM

**GSM850 Right touch 190ch/Area Scan (61x91x1):** Measurement grid: dx=15mm, dy=15mm

Info: [Interpolated medium parameters used for SAR evaluation.](#)

Maximum value of SAR (interpolated) = 0.469 mW/g

**GSM850 Right touch 190ch/Zoom Scan (5x5x7)/Cube 0:** Measurement grid: dx=8mm, dy=8mm, dz=5mm

Reference Value = 7.19 V/m; Power Drift = -0.139 dB

Peak SAR (extrapolated) = 0.534 W/kg

**SAR(1 g) = 0.416 mW/g; SAR(10 g) = 0.300 mW/g**

Info: [Interpolated medium parameters used for SAR evaluation.](#)

Maximum value of SAR (measured) = 0.443 mW/g

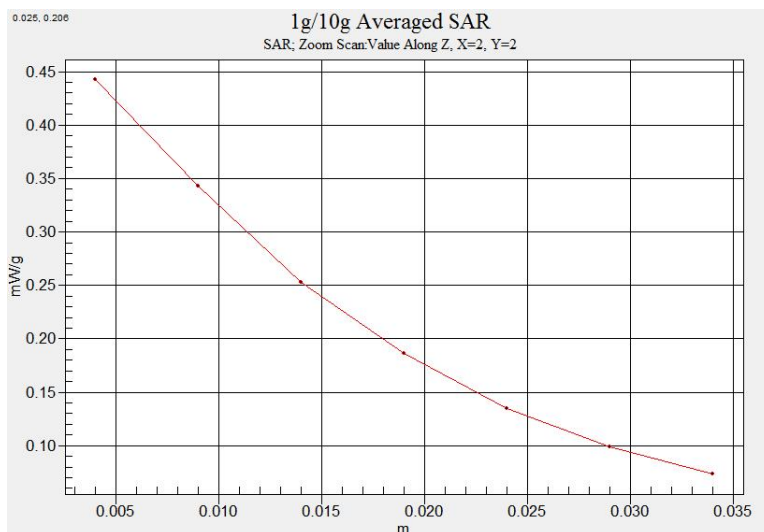



Test Laboratory: HCT CO., LTD  
 EUT Type: Cellular/PCS GSM/GPRS/EDGE(RX Only) Phone with Bluetooth, WLAN.  
 Liquid Temperature: 22.7 °C  
 Ambient Temperature: 22.9 °C  
 Test Date: Jun . 28, 2013  
 Plot NO. 9

**DUT: LG-T585; Type: bar; Serial: #1**

Communication System: GSM 1900; Frequency: 1880 MHz; Duty Cycle: 1:8.3  
 Medium parameters used:  $f = 1880$  MHz;  $\sigma = 1.39$  mho/m;  $\epsilon_r = 39.8$ ;  $\rho = 1000$  kg/m<sup>3</sup>  
 Phantom section: Left Section ; Measurement SW: DASY4, V4.7 Build 80; Postprocessing SW: SEMCAD, V1.8 Build 184

DASY4 Configuration:

- Probe: ET3DV6 - SN1798; ConvF(5.29, 5.29, 5.29); Calibrated: 2013-04-29
- Sensor-Surface: 4mm (Mechanical Surface Detection)
- Electronics: DAE3 Sn466; Calibrated: 2013-02-21
- Phantom: SAM 1800/1900 MHz; Type: SAM

**GSM1900 Left Touch 661ch/Area Scan (61x91x1):** Measurement grid: dx=15mm, dy=15mm

Maximum value of SAR (interpolated) = 1.00 mW/g

**GSM1900 Left Touch 661ch/Zoom Scan (5x5x7)/Cube 0:** Measurement grid: dx=8mm, dy=8mm, dz=5mm

Reference Value = 6.58 V/m; Power Drift = 0.128 dB

Peak SAR (extrapolated) = 1.23 W/kg

**SAR(1 g) = 0.834 mW/g; SAR(10 g) = 0.505 mW/g**

Maximum value of SAR (measured) = 0.926 mW/g

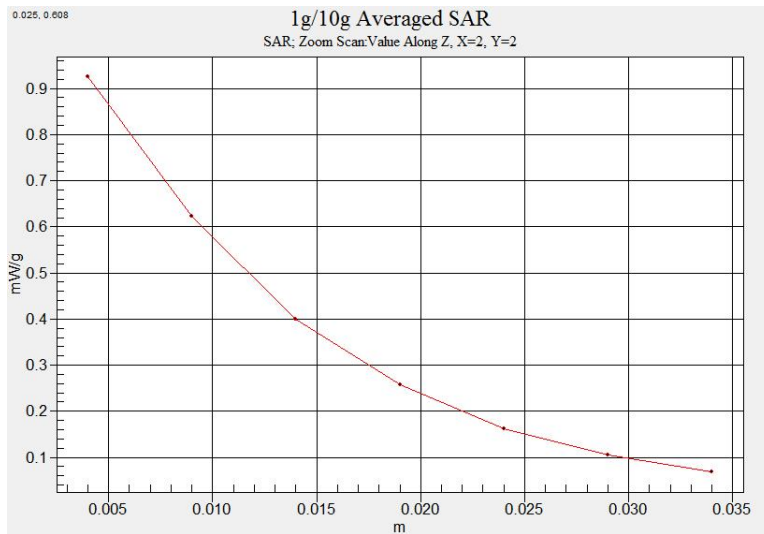

Test Laboratory: HCT CO., LTD  
 EUT Type: Cellular/PCS GSM/GPRS/EDGE(RX Only) Phone with Bluetooth, WLAN.  
 Liquid Temperature: 22.4 °C  
 Ambient Temperature: 22.6 °C  
 Test Date: Jun . 26, 2013  
 Plot NO. 10

**DUT: LG-T585; Type: bar; Serial: #1**

Communication System: 2450MHz FCC; Frequency: 2412 MHz;Duty Cycle: 1:1  
 Medium parameters used (interpolated):  $f = 2412$  MHz;  $\sigma = 1.77$  mho/m;  $\epsilon_r = 39.5$ ;  $\rho = 1000$  kg/m<sup>3</sup>  
 Phantom section: Right Section ; Measurement SW: DASY4, V4.7 Build 80; Postprocessing SW: SEMCAD, V1.8 Build 184

DASY4 Configuration:

- Probe: ET3DV6 - SN1798; ConvF(4.63, 4.63, 4.63); Calibrated: 2013-04-29
- Sensor-Surface: 4mm (Mechanical Surface Detection)
- Electronics: DAE3 Sn466; Calibrated: 2013-02-21
- Phantom: 835/900 Phantom ; Type: SAM

**WiFi2450 Right touch 1ch/Area Scan (71x111x1):** Measurement grid: dx=12mm, dy=12mm

Info: [Interpolated medium parameters used for SAR evaluation.](#)

Maximum value of SAR (interpolated) = 0.480 mW/g

**WiFi2450 Right touch 1ch/Zoom Scan (7x7x7)/Cube 0:** Measurement grid: dx=5mm, dy=5mm, dz=5mm

Reference Value = 7.84 V/m; Power Drift = 0.088 dB

Peak SAR (extrapolated) = 1.04 W/kg

**SAR(1 g) = 0.449 mW/g; SAR(10 g) = 0.206 mW/g**

Info: [Interpolated medium parameters used for SAR evaluation.](#)

Maximum value of SAR (measured) = 0.526 mW/g

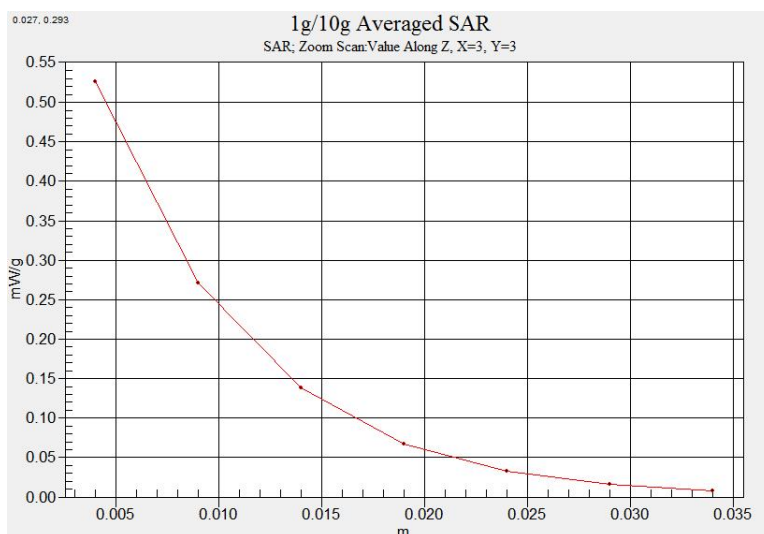

Test Laboratory: HCT CO., LTD  
 EUT Type: Cellular/PCS GSM/GPRS/EDGE(RX Only) Phone with Bluetooth, WLAN.  
 Liquid Temperature: 22.6 °C  
 Ambient Temperature: 22.8 °C  
 Test Date: Jun . 27, 2013  
 Plot NO. 11

**DUT: LG-T585; Type: bar; Serial: #1**

Communication System: GSM 850; Frequency: 836.6 MHz; Duty Cycle: 1:8.3  
 Medium parameters used (interpolated):  $f = 836.6$  MHz;  $\sigma = 0.983$  mho/m;  $\epsilon_r = 56.9$ ;  $\rho = 1000$  kg/m<sup>3</sup>  
 Phantom section: Center Section ; Measurement SW: DASY4, V4.7 Build 80; Postprocessing SW: SEMCAD, V1.8 Build 184

DASY4 Configuration:

- Probe: ET3DV6 - SN1798; ConvF(6.46, 6.46, 6.46); Calibrated: 2013-04-29
- Sensor-Surface: 4mm (Mechanical Surface Detection)
- Electronics: DAE3 Sn466; Calibrated: 2013-02-21
- Phantom: Triple Flat Phantom 5.1C; Type: QD 000 P51 CA

**GSM850 Body rear 190ch/Area Scan (61x91x1):** Measurement grid: dx=15mm, dy=15mm

Info: [Interpolated medium parameters used for SAR evaluation.](#)

Maximum value of SAR (interpolated) = 0.472 mW/g

**GSM850 Body rear 190ch/Zoom Scan (5x5x7)/Cube 0:** Measurement grid: dx=8mm, dy=8mm, dz=5mm

Reference Value = 10.2 V/m; Power Drift = -0.080 dB

Peak SAR (extrapolated) = 0.562 W/kg

**SAR(1 g) = 0.444 mW/g; SAR(10 g) = 0.322 mW/g**

Info: [Interpolated medium parameters used for SAR evaluation.](#)

Maximum value of SAR (measured) = 0.473 mW/g

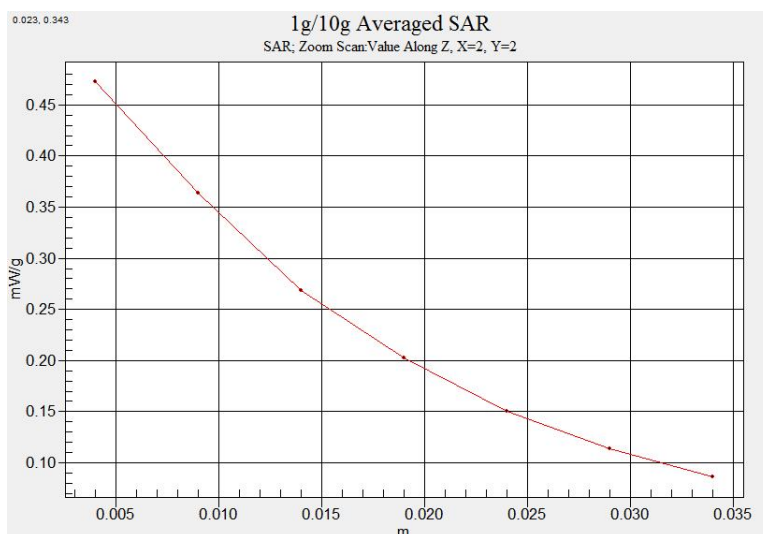

Test Laboratory: HCT CO., LTD  
 EUT Type: Cellular/PCS GSM/GPRS/EDGE(RX Only) Phone with Bluetooth, WLAN.  
 Liquid Temperature: 22.7 °C  
 Ambient Temperature: 22.9 °C  
 Test Date: Jun . 28, 2013  
 Plot NO. 12

**DUT: LG-T585; Type: bar; Serial: #1**

Communication System: GSM 1900; Frequency: 1880 MHz; Duty Cycle: 1:8.3  
 Medium parameters used:  $f = 1880$  MHz;  $\sigma = 1.53$  mho/m;  $\epsilon_r = 52.2$ ;  $\rho = 1000$  kg/m<sup>3</sup>  
 Phantom section: Center Section ; Measurement SW: DASY4, V4.7 Build 80; Postprocessing SW: SEMCAD, V1.8 Build 184

DASY4 Configuration:

- Probe: ET3DV6 - SN1798; ConvF(4.7, 4.7, 4.7); Calibrated: 2013-04-29
- Sensor-Surface: 4mm (Mechanical Surface Detection)
- Electronics: DAE3 Sn466; Calibrated: 2013-02-21
- Phantom: Triple Flat Phantom 5.1C; Type: QD 000 P51 CA

**GSM1900 Body rear 661ch/Area Scan (61x91x1):** Measurement grid: dx=15mm, dy=15mm

Maximum value of SAR (interpolated) = 0.240 mW/g

**GSM1900 Body rear 661ch/Zoom Scan (5x5x7)/Cube 0:** Measurement grid:

dx=8mm, dy=8mm, dz=5mm

Reference Value = 10.4 V/m; Power Drift = -0.041 dB

Peak SAR (extrapolated) = 0.306 W/kg

**SAR(1 g) = 0.220 mW/g; SAR(10 g) = 0.145 mW/g**

Maximum value of SAR (measured) = 0.237 mW/g

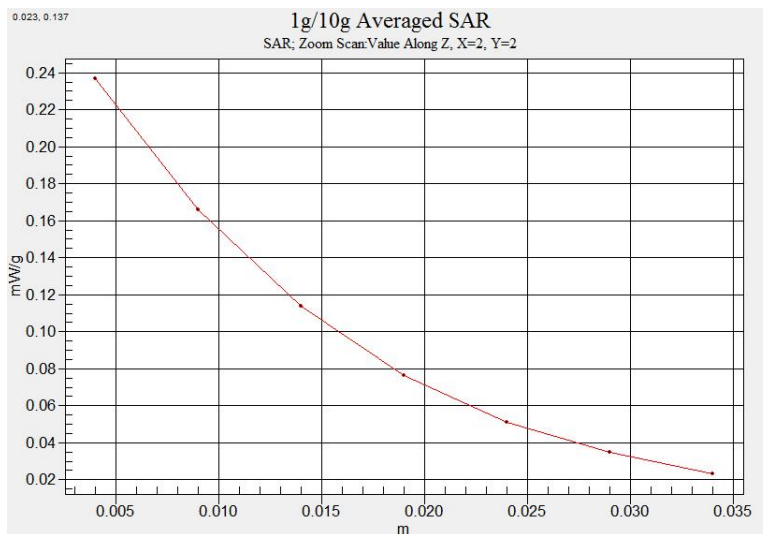

Test Laboratory: HCT CO., LTD  
 EUT Type: Cellular/PCS GSM/GPRS/EDGE(RX Only) Phone with Bluetooth, WLAN.  
 Liquid Temperature: 22.4 °C  
 Ambient Temperature: 22.6 °C  
 Test Date: Jun . 26, 2013  
 Plot NO. 13

**DUT: LG-P585; Type: bar; Serial: #1**

Communication System: 2450MHz FCC; Frequency: 2412 MHz;Duty Cycle: 1:1  
 Medium parameters used (interpolated):  $f = 2412$  MHz;  $\sigma = 1.89$  mho/m;  $\epsilon_r = 53.8$ ;  $\rho = 1000$  kg/m<sup>3</sup>  
 Phantom section: Center Section ; Measurement SW: DASY4, V4.7 Build 80; Postprocessing SW: SEMCAD, V1.8 Build 186

DASY4 Configuration:

- Probe: ET3DV6 - SN1798; ConvF(4.16, 4.16, 4.16); Calibrated: 2013-04-29
- Sensor-Surface: 4mm (Mechanical Surface Detection)
- Electronics: DAE3 Sn466; Calibrated: 2013-02-21
- Phantom: Triple Flat Phantom 5.1C; Type: QD 000 P51 CA

**WiFi2450 Body rear 1ch/Area Scan (71x111x1):** Measurement grid: dx=12mm, dy=12mm

Info: [Interpolated medium parameters used for SAR evaluation.](#)

Maximum value of SAR (interpolated) = 0.068 mW/g

**WiFi2450 Body rear 1ch/Zoom Scan (7x7x7)/Cube 0:** Measurement grid: dx=5mm, dy=5mm, dz=5mm

Reference Value = 3.56 V/m; Power Drift = 0.182 dB

Peak SAR (extrapolated) = 0.158 W/kg

**SAR(1 g) = 0.062 mW/g; SAR(10 g) = 0.029 mW/g**

Info: [Interpolated medium parameters used for SAR evaluation.](#)

Maximum value of SAR (measured) = 0.067 mW/g

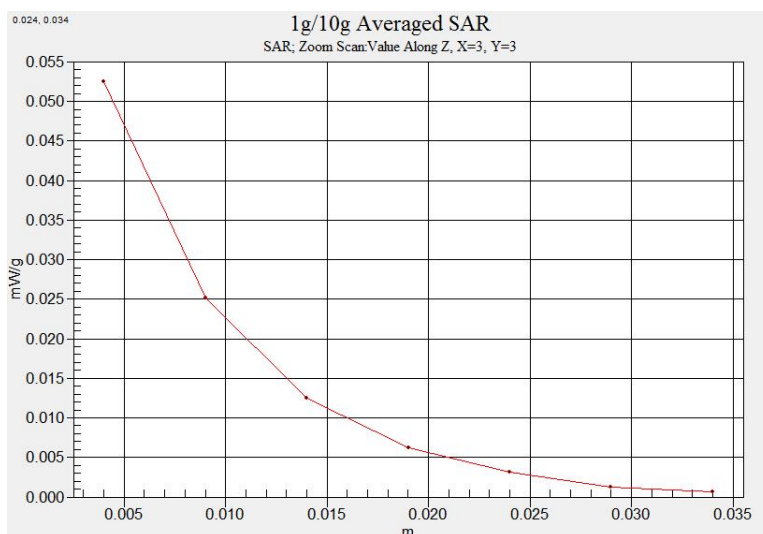

## Attachment 2. – Dipole Verification Plots

## ■ Verification Data (835 MHz Head)

Test Laboratory: HCT CO., LTD  
Input Power 100 mW (20 dBm)  
Liquid Temp: 22.6 °C  
Test Date: Jun. 27, 2013

**DUT: Dipole 835 MHz; Type: D835V2; Serial: D835V2 – SN:441**

Communication System: CW; Frequency: 835 MHz; Duty Cycle: 1:1  
Medium parameters used:  $f = 835$  MHz;  $\sigma = 0.918$  mho/m;  $\epsilon_r = 40.4$ ;  $\rho = 1000$  kg/m<sup>3</sup>  
Phantom section: Flat Section ; Measurement SW: DASY4, V4.7 Build 80; Postprocessing SW: SEMCAD, V1.8 Build 184

DASY4 Configuration:

- Probe: ET3DV6 – SN1798; ConvF(6.64, 6.64, 6.64); Calibrated: 2013-04-29
- Sensor-Surface: 4mm (Mechanical Surface Detection)
- Electronics: DAE3 Sn466; Calibrated: 2013-02-21
- Phantom: 1800/1900 Phantom; Type: SAM

**Validation 835 MHz/Area Scan (61x81x1):** Measurement grid: dx=15mm, dy=15mm  
Maximum value of SAR (interpolated) = 1.00 mW/g

**Validation 835 MHz/Zoom Scan (5x5x7)/Cube 0:** Measurement grid: dx=8mm, dy=8mm, dz=5mm  
Reference Value = 34.1 V/m; Power Drift = -0.026 dB  
Peak SAR (extrapolated) = 1.37 W/kg  
**SAR(1 g) = 0.934 mW/g; SAR(10 g) = 0.610 mW/g**  
Maximum value of SAR (measured) = 1.01 mW/g

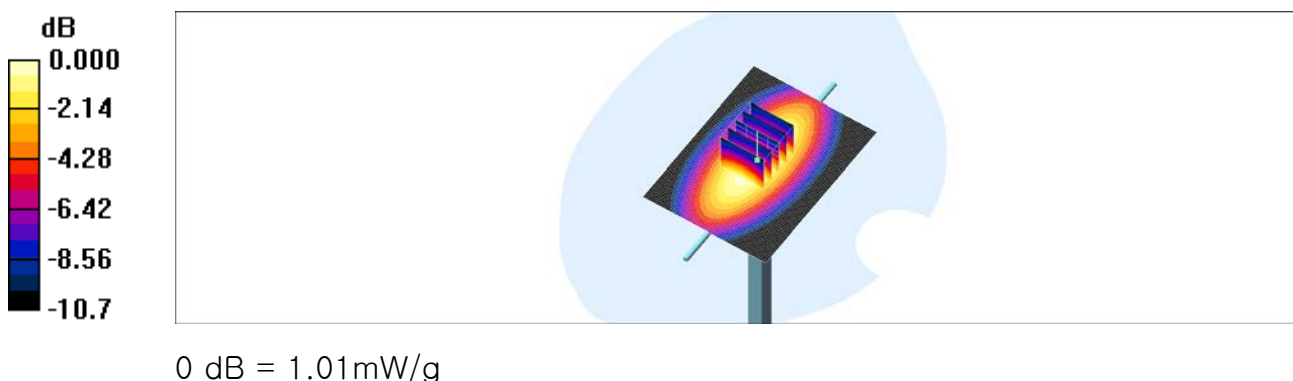

## ■ Verification Data (835 MHz Body)

Test Laboratory: HCT CO., LTD  
 Input Power 100 mW (20 dBm)  
 Liquid Temp: 22.6 °C  
 Test Date: Jun. 27, 2013

**DUT: Dipole 835 MHz; Type: D835V2; Serial: D835V2 – SN:441**

Communication System: CW; Frequency: 835 MHz; Duty Cycle: 1:1  
 Medium parameters used:  $f = 835 \text{ MHz}$ ;  $\sigma = 0.982 \text{ mho/m}$ ;  $\epsilon_r = 56.9$ ;  $\rho = 1000 \text{ kg/m}^3$   
 Phantom section: Center Section ; Measurement SW: DASY4, V4.7 Build 80; Postprocessing SW: SEMCAD, V1.8 Build 184

DASY4 Configuration:

- Probe: ET3DV6 – SN1798; ConvF(6.46, 6.46, 6.46); Calibrated: 2013-04-29
- Sensor-Surface: 4mm (Mechanical Surface Detection)
- Electronics: DAE3 Sn466; Calibrated: 2013-02-21
- Phantom: Triple Flat Phantom 5.1C; Type: QD 000 P51 CA

**Validation 835 MHz/Area Scan (111x61x1):** Measurement grid:  $dx=15\text{mm}$ ,  $dy=15\text{mm}$   
 Maximum value of SAR (interpolated) = 1.05 mW/g

**Validation 835 MHz/Zoom Scan (5x5x7)/Cube 0:** Measurement grid:  $dx=8\text{mm}$ ,  $dy=8\text{mm}$ ,  $dz=5\text{mm}$   
 Reference Value = 33.7 V/m; Power Drift = -0.005 dB  
 Peak SAR (extrapolated) = 1.41 W/kg  
**SAR(1 g) = 0.959 mW/g; SAR(10 g) = 0.621 mW/g**  
 Maximum value of SAR (measured) = 1.04 mW/g

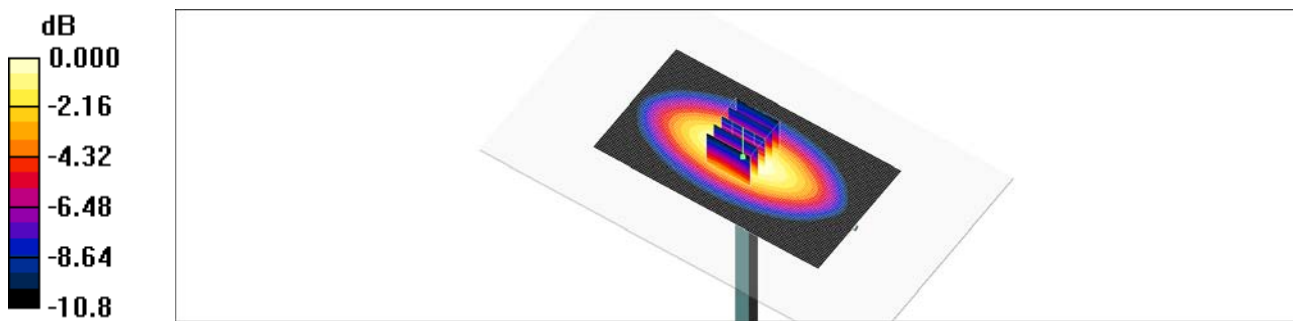

0 dB = 1.04mW/g



**■ Verification Data (1 900 MHz Head)**

Test Laboratory: HCT CO., LTD  
 Input Power: 100 mW (20 dBm)  
 Liquid Temp: 22.7 °C  
 Test Date: Jun. 28, 2013

**DUT: Dipole 1900 MHz; Type: D1900V2; Serial: D1900V2 – SN:5d032**

Communication System: CW; Frequency: 1900 MHz; Duty Cycle: 1:1  
 Medium parameters used:  $f = 1900$  MHz;  $\sigma = 1.41$  mho/m;  $\epsilon_r = 39.7$ ;  $\rho = 1000$  kg/m<sup>3</sup>  
 Phantom section: Flat Section ; Measurement SW: DASY4, V4.7 Build 80; Postprocessing SW: SEMCAD, V1.8 Build 184

DASY4 Configuration:

- Probe: ET3DV6 – SN1798; ConvF(5.29, 5.29, 5.29); Calibrated: 2013-04-29
- Sensor-Surface: 4mm (Mechanical Surface Detection)
- Electronics: DAE3 Sn466; Calibrated: 2013-02-21
- Phantom: SAM 1800/1900 MHz; Type: SAM

**Dipole 1900MHz Validation/Area Scan (61x61x1):** Measurement grid: dx=15mm, dy=15mm

Maximum value of SAR (interpolated) = 4.61 mW/g

**Dipole 1900MHz Validation/Zoom Scan (5x5x7)/Cube 0:** Measurement grid: dx=8mm, dy=8mm, dz=5mm

Reference Value = 58.0 V/m; Power Drift = -0.009 dB

Peak SAR (extrapolated) = 6.74 W/kg

**SAR(1 g) = 3.86 mW/g; SAR(10 g) = 1.98 mW/g**

Maximum value of SAR (measured) = 4.32 mW/g

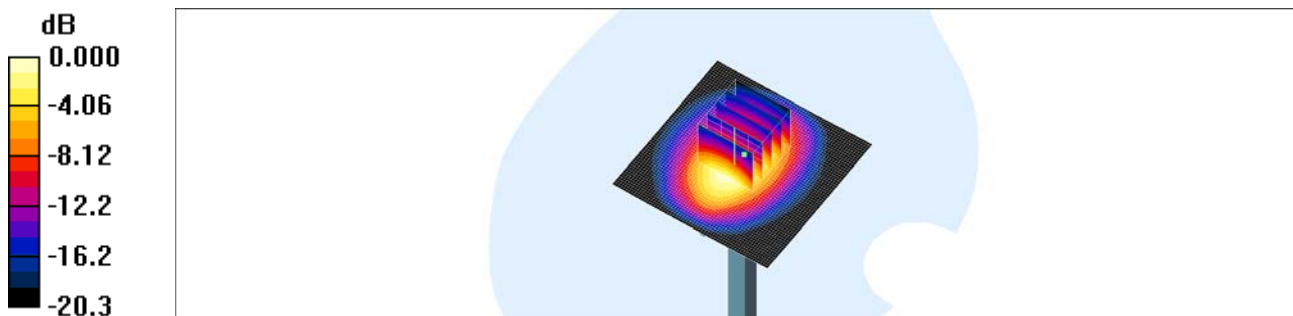

0 dB = 4.32mW/g

## ■ Verification Data (1 900 MHz Body)

Test Laboratory: HCT CO., LTD  
Input Power: 100 mW (20 dBm)  
Liquid Temp: 22.7 °C  
Test Date: Jun. 28, 2013

**DUT: Dipole 1900 MHz; Type: D1900V2; Serial: D1900V2 – SN:5d032**

Communication System: CW; Frequency: 1900 MHz; Duty Cycle: 1:1  
Medium parameters used:  $f = 1900$  MHz;  $\sigma = 1.55$  mho/m;  $\epsilon_r = 52.2$ ;  $\rho = 1000$  kg/m<sup>3</sup>  
Phantom section: Center Section ; Measurement SW: DASY4, V4.7 Build 80; Postprocessing SW: SEMCAD, V1.8 Build 184

DASY4 Configuration:

- Probe: ET3DV6 – SN1798; ConvF(4.7, 4.7, 4.7); Calibrated: 2013-04-29
- Sensor-Surface: 4mm (Mechanical Surface Detection)
- Electronics: DAE3 Sn466; Calibrated: 2013-02-21
- Phantom: Triple Flat Phantom 5.1C\_20120905; Type: QD 000 P51 CA

**Validation 1900 MHz/Area Scan (61x61x1):** Measurement grid: dx=15mm, dy=15mm  
Maximum value of SAR (interpolated) = 4.56 mW/g

**Validation 1900 MHz/Zoom Scan (5x5x7)/Cube 0:** Measurement grid: dx=8mm, dy=8mm, dz=5mm

Reference Value = 56.3 V/m; Power Drift = -0.030 dB

Peak SAR (extrapolated) = 6.39 W/kg

**SAR(1 g) = 3.9 mW/g; SAR(10 g) = 2.11 mW/g**

Maximum value of SAR (measured) = 4.37 mW/g

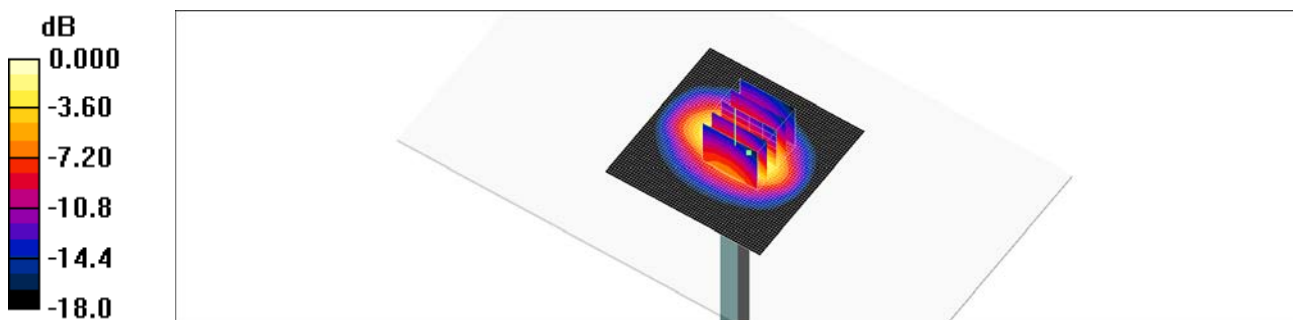

0 dB = 4.37mW/g

**■ Verification Data (2 450 MHz Head)**

Test Laboratory: HCT CO., LTD  
 Input Power: 100 mW (20 dBm)  
 Liquid Temp: 22.4 °C  
 Test Date: Jun. 26, 2013

**DUT: Dipole 2450 MHz; Type: D2450V2; Serial: D2450V2 – SN:743**

Communication System: CW; Frequency: 2450 MHz; Duty Cycle: 1:1  
 Medium parameters used:  $f = 2450 \text{ MHz}$ ;  $\sigma = 1.81 \text{ mho/m}$ ;  $\epsilon_r = 39.4$ ;  $\rho = 1000 \text{ kg/m}^3$   
 Phantom section: Flat Section ; Measurement SW: DASY4, V4.7 Build 80; Postprocessing SW: SEMCAD, V1.8 Build 184

DASY4 Configuration:  
 - Probe: ET3DV6 – SN1798; ConvF(4.63, 4.63, 4.63); Calibrated: 2013-04-29  
 - Sensor-Surface: 4mm (Mechanical Surface Detection)  
 - Electronics: DAE3 Sn466; Calibrated: 2013-02-21  
 - Phantom: 835/900 Phantom ; Type: SAM

**Validation 2450MHz/Area Scan (81x81x1):** Measurement grid:  $dx=12\text{mm}$ ,  $dy=12\text{mm}$   
 Maximum value of SAR (interpolated) = 5.98 mW/g

**Validation 2450MHz/Zoom Scan (7x7x7)/Cube 0:** Measurement grid:  $dx=5\text{mm}$ ,  $dy=5\text{mm}$ ,  $dz=5\text{mm}$   
 Reference Value = 53.5 V/m; Power Drift = -0.119 dB  
 Peak SAR (extrapolated) = 12.3 W/kg  
**SAR(1 g) = 5.28 mW/g; SAR(10 g) = 2.36 mW/g**  
 Maximum value of SAR (measured) = 5.83 mW/g

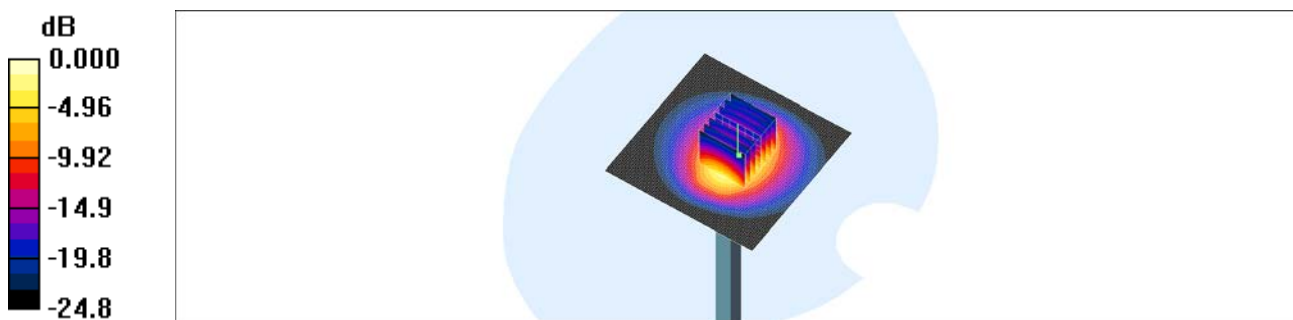

0 dB = 5.83mW/g

## ■ Verification Data (2 450 MHz Body)

Test Laboratory: HCT CO., LTD  
Input Power: 100 mW (20 dBm)  
Liquid Temp: 22.4 °C  
Test Date: Jun. 26, 2013

**DUT: Dipole 2450 MHz; Type: D2450V2; Serial: D2450V2 – SN:743**

Communication System: CW; Frequency: 2450 MHz; Duty Cycle: 1:1  
Medium parameters used:  $f = 2450$  MHz;  $\sigma = 1.94$  mho/m;  $\epsilon_r = 53.7$ ;  $\rho = 1000$  kg/m<sup>3</sup>  
Phantom section: Center Section ; Measurement SW: DASY4, V4.7 Build 80; Postprocessing SW: SEMCAD, V1.8 Build 184

DASY4 Configuration:

- Probe: ET3DV6 – SN1798; ConvF(4.16, 4.16, 4.16); Calibrated: 2013-04-29
- Sensor-Surface: 4mm (Mechanical Surface Detection)
- Electronics: DAE3 Sn466; Calibrated: 2013-02-21
- Phantom: Triple Flat Phantom 5.1C; Type: QD 000 P51 CA

**Validation 2450MHz/Area Scan (81x81x1):** Measurement grid: dx=12mm, dy=12mm

**Validation 2450MHz/Zoom Scan (7x7x7)/Cube 0:** Measurement grid: dx=5mm, dy=5mm, dz=5mm

Reference Value = 48.1 V/m; Power Drift = -0.032 dB

Peak SAR (extrapolated) = 14.0 W/kg

**SAR(1 g) = 5.19 mW/g; SAR(10 g) = 2.28 mW/g**

Maximum value of SAR (interpolated) = 5.78 mW/g

Maximum value of SAR (measured) = 5.59 mW/g

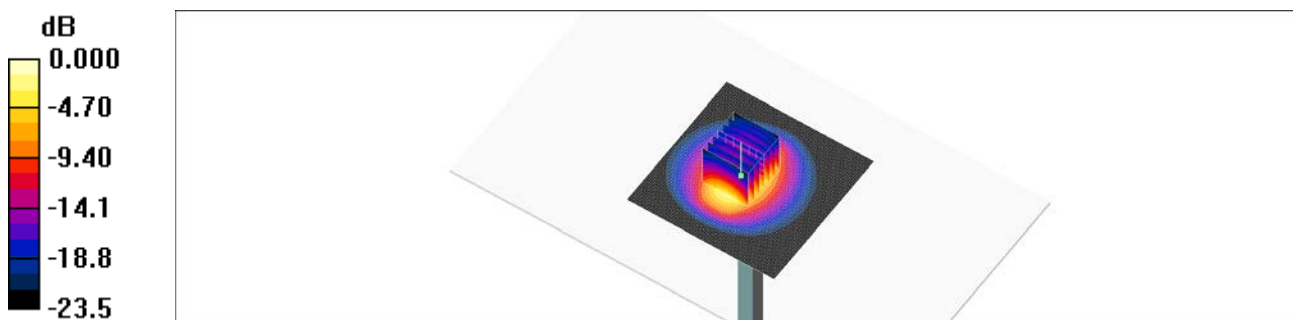

0 dB = 5.59mW/g