

**FCC 47 CFR PART 15 SUBPART C &  
INDUSTRY CANADA RSS-247**

**TEST REPORT**

**For**

**Rolling Bot**

**Model: LG-RB200**

**Trade Name: LG**

*Issued to*

**For FCC ID:  
LG Electronics MobileComm USA, Inc.  
1000 Sylvan Avenue, Englewood Cliffs, NJ 07632 U.S.A.**

**For ISED:  
LG ELECTRONICS INC  
60-39, Gasan-Dong, Gumchon-Gu, Seoul 153-801 Korea (Rep.)**

*Issued by*

**Compliance Certification Services Inc.  
No.11, Wugong 6th Rd., Wugu Dist.,  
New Taipei City 24891, Taiwan. (R.O.C.)  
<http://www.ccsrf.com>  
[service@ccsrf.com](mailto:service@ccsrf.com)  
Issued Date: June 2, 2016**



---

**Note:** This report shall not be reproduced except in full, without the written approval of Compliance Certification Services Inc. This document may be altered or revised by Compliance Certification Services Inc. personnel only, and shall be noted in the revision section of the document.

**Revision History**

Rev.	Issue Date	Revisions	Effect Page	Revised By
00	June 2, 2016	Initial Issue	ALL	Becca Chen
01	June 16, 2016	Delete IC RSS-102 standard.	P6	Becca Chen

## TABLE OF CONTENTS

<b>1. TEST RESULT CERTIFICATION.....</b>	<b>4</b>
<b>2. EUT DESCRIPTION.....</b>	<b>5</b>
<b>3. TEST METHODOLOGY.....</b>	<b>6</b>
3.1 EUT CONFIGURATION.....	6
3.2 EUT EXERCISE.....	6
3.3 GENERAL TEST PROCEDURES.....	6
3.4 FCC PART 15.205 RESTRICTED BANDS OF OPERATIONS.....	7
3.5 DESCRIPTION OF TEST MODES.....	8
<b>4. INSTRUMENT CALIBRATION.....</b>	<b>9</b>
4.1 MEASURING INSTRUMENT CALIBRATION.....	9
4.2 MEASUREMENT EQUIPMENT USED.....	9
4.3 MEASUREMENT UNCERTAINTY.....	10
<b>5. FACILITIES AND ACCREDITATIONS.....</b>	<b>11</b>
5.1 FACILITIES.....	11
5.2 EQUIPMENT.....	11
5.3 LABORATORY ACCREDITATIONS AND LISTING.....	11
5.4 TABLE OF ACCREDITATIONS AND LISTINGS.....	12
<b>6. SETUP OF EQUIPMENT UNDER TEST.....</b>	<b>13</b>
6.1 SETUP CONFIGURATION OF EUT.....	13
6.2 SUPPORT EQUIPMENT.....	13
<b>7. FCC PART 15.247 REQUIREMENTS &amp; RSS-247 REQUIREMENTS.....</b>	<b>14</b>
7.1 99% BANDWIDTH.....	14
7.2 6DB BANDWIDTH.....	24
7.3 PEAK POWER.....	34
7.4 AVERAGE POWER.....	36
7.5 BAND EDGES MEASUREMENT.....	38
7.6 PEAK POWER SPECTRAL DENSITY.....	72
7.7 RADIATED EMISSIONS.....	82
7.8 POWERLINE CONDUCTED EMISSIONS.....	112
<b>APPENDIX II PHOTOGRAPHS OF TEST SETUP.....</b>	<b>115</b>

## 1. TEST RESULT CERTIFICATION

**Applicant:** **For FCC ID:**  
 LG Electronics MobileComm USA, Inc.  
 1000 Sylvan Avenue, Englewood Cliffs, NJ 07632 U.S.A.

**For ISED:**  
 LG ELECTRONICS INC  
 60-39, Gasan-Dong, Gumchon-Gu, Seoul 153-801 Korea  
 (Rep.)

**Manufacturer:** Altek (Kunshan) Co. Ltd.  
 No. 77, 3rd Main Street, Kunshan Free Trade Zone, Jiangsu  
 Province, 215301, China

**Equipment Under Test:** Rolling Bot

**Model Number:** LG-RB200

**Trade Name:** LG

**Date of Test:** April 12 ~ May 4, 2016

APPLICABLE STANDARDS	
STANDARD	TEST RESULT
FCC 47 CFR Part 15 Subpart C Industry Canada RSS-247 Issue 1	No non-compliance noted

### We hereby certify that:

The above equipment was tested by Compliance Certification Services Inc. The test data, data evaluation, test procedures, and equipment configurations shown in this report were made in accordance with the procedures given in ANSI C63.10: 2013 and the energy emitted by the sample EUT tested as described in this report is in compliance with the requirements of FCC Rules Part 15.207, 15.209, 15.247 and Industry Canada RSS-247.

The test results of this report relate only to the tested sample EUT identified in this report.

*Approved by:*

*Tested by:*

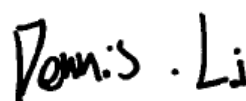
\_\_\_\_\_  
 Miller Lee  
 Manager  
 Compliance Certification Services Inc.

\_\_\_\_\_  
 Dennis Li  
 Engineer  
 Compliance Certification Services Inc.

## 2. EUT DESCRIPTION

<b>Product</b>	Rolling Bot			
<b>Model Number</b>	LG-RB200			
<b>Trade Name</b>	LG			
<b>Model Discrepancy</b>	N/A			
<b>Received Date</b>	April 7, 2016			
<b>Power supply</b>	1. VDC from Power Adapter ADAPTER TECH. / ATS036T-A120 I/P: 100-240Vac ~ 50-60Hz, 1A MAX. O/P: 12Vdc, 3A 2. Power from Rechargeable Li-ion Battery*2 / Model: ID729 Rating: 7.4V, 2600mAh (19.24Wh)			
<b>Frequency Range</b>	2412 ~ 2462 MHz			
<b>Transmit Power</b>	<b>Mode</b>	<b>Frequency Range</b>	<b>Output Power (dBm)</b>	<b>Output Power (W)</b>
	IEEE 802.11b	2412 - 2462	18.74	0.0748
	IEEE 802.11g	2412 - 2462	22.83	0.1919
	IEEE 802.11n HT 20 MHz	2412 - 2462	22.47	0.1766
	IEEE 802.11n HT 40 MHz	2422 - 2452	22.34	0.1714
<b>Number of Channels</b>	IEEE 802.11b/g mode: 11 Channels IEEE 802.11n HT 20 MHz mode: 11 Channels IEEE 802.11n HT 40 MHz mode: 7 Channels			
<b>Antenna Specification</b>	MAG LAYERS / FPA-5321-25GC2-A1-AH FPC Antenna / Gain: 1.72dBi			

**Remark:**

1. The sample selected for test was engineering sample that approximated to production product and was provided by manufacturer.
2. This submittal(s) (test report) is intended for FCC ID: **ZNFRB200** & ISED No. : **2703C-RB200** filing to comply with FCC Part 15C, Section 15.207, 15.209 and IC RSS-247 & RSS-GEN.

### **3. TEST METHODOLOGY**

The tests documented in this report were performed in accordance with ANSI C63.10: 2013 and FCC CFR 47 Part 15.207, 15.209, 15.247, KDB 558074 D01 DTS Meas Guidance v03r05

The tests documented in this report were performed in accordance with IC RSS-247, IC RSS-Gen and ANSI C63.10:2013.

This submittal(s) (test report) is intended for IC Certification with Industry Canada RSS-247.

#### **3.1 EUT CONFIGURATION**

The EUT configuration for testing is installed on RF field strength measurement to meet the Commissions requirement and operating in a manner that intends to maximize its emission characteristics in a continuous normal application.

#### **3.2 EUT EXERCISE**

The EUT was operated in the engineering mode to fix the TX frequency that was for the purpose of the measurements.

According to its specifications, the EUT must comply with the requirements of the Section 15.207, 15.209 and 15.247 under the FCC Rules Part 15 Subpart C.

The tests documented in this report were performed in accordance with IC RSS-247, IC RSS-Gen, and ANSI C63.10: 2013.

#### **3.3 GENERAL TEST PROCEDURES**

##### **Conducted Emissions**

According to the requirements in ANSI C63.10: 2013 Conducted emissions from the EUT measured in the frequency range between 0.15 MHz and 30MHz using CISPR Quasi-peak and average detector modes.

##### **Radiated Emissions**

The EUT is placed on a turn table, which is 1.5 m above ground plane. The turntable shall rotate 360 degrees to determine the position of maximum emission level. EUT is set 3m away from the receiving antenna, which varied from 1m to 4m to find out the highest emission. And also, each emission was to be maximized by changing the polarization of receiving antenna both horizontal and vertical. In order to find out the maximum emissions, exploratory radiated emission measurements were made according to the requirements in ANSI C63.10: 2013.

### 3.4 FCC PART 15.205 RESTRICTED BANDS OF OPERATIONS

(a) Except as shown in paragraph (d) of this section, only spurious emissions are permitted in any of the frequency bands listed below:

MHz	MHz	MHz	GHz
0.090 - 0.110	16.42 - 16.423	399.9 - 410	4.5 - 5.15
<sup>1</sup> 0.495 - 0.505	16.69475 - 16.69525	608 - 614	5.35 - 5.46
2.1735 - 2.1905	16.80425 - 16.80475	960 - 1240	7.25 - 7.75
4.125 - 4.128	25.5 - 25.67	1300 - 1427	8.025 - 8.5
4.17725 - 4.17775	37.5 - 38.25	1435 - 1626.5	9.0 - 9.2
4.20725 - 4.20775	73 - 74.6	1645.5 - 1646.5	9.3 - 9.5
6.215 - 6.218	74.8 - 75.2	1660 - 1710	10.6 - 12.7
6.26775 - 6.26825	108 - 121.94	1718.8 - 1722.2	13.25 - 13.4
6.31175 - 6.31225	123 - 138	2200 - 2300	14.47 - 14.5
8.291 - 8.294	149.9 - 150.05	2310 - 2390	15.35 - 16.2
8.362 - 8.366	156.52475 -	2483.5 - 2500	17.7 - 21.4
8.37625 - 8.38675	156.52525	2655 - 2900	22.01 - 23.12
8.41425 - 8.41475	156.7 - 156.9	3260 - 3267	23.6 - 24.0
12.29 - 12.293	162.0125 - 167.17	3332 - 3339	31.2 - 31.8
12.51975 - 12.52025	167.72 - 173.2	3345.8 - 3358	36.43 - 36.5
12.57675 - 12.57725	240 - 285	3600 - 4400	( <sup>2</sup> )
13.36 - 13.41	322 - 335.4		

<sup>1</sup> Until February 1, 1999, this restricted band shall be 0.490-0.510 MHz.

<sup>2</sup> Above 38.6

(b) Except as provided in paragraphs (d) and (e), the field strength of emissions appearing within these frequency bands shall not exceed the limits shown in Section 15.209. At frequencies equal to or less than 1000 MHz, compliance with the limits in Section 15.209 shall be demonstrated using measurement instrumentation employing a CISPR quasi-peak detector. Above 1000 MHz, compliance with the emission limits in Section 15.209 shall be demonstrated based on the average value of the measured emissions. The provisions in Section 15.35 apply to these measurements.

### 3.5 DESCRIPTION OF TEST MODES

The EUT (model: LG-RB200) had been tested under operating condition.

Software used to control the EUT for staying in continuous transmitting and receiving mode was programmed.

After verification, all tests carried out are with the worst-case test modes as shown below except radiated spurious emission below 1GHz and power line conducted emissions below 30MHz, which worst case was in normal link mode and receiving radiated spurious emission above 1GHz, which worst case was in CH Mid mode only.

**IEEE 802.11b mode:**

Channel Low (2412MHz), Channel Mid (2437MHz) and Channel High (2462MHz) with 1Mbps data rate were chosen for full testing.

**IEEE 802.11g mode:**

Channel Low (2412MHz), Channel Mid (2437MHz) and Channel High (2462MHz) with 6Mbps data rate were chosen for full testing.

**IEEE 802.11n HT 20 MHz mode:**

Channel Low (2412MHz), Channel Mid (2437MHz) and Channel High (2462MHz) with 6.5Mbps data rate were chosen for full testing.

**IEEE 802.11n HT 40 MHz mode:**

Channel Low (2422MHz), Channel Mid (2437MHz) and Channel High (2452MHz) with 13.5Mbps data rate were chosen for full testing.

The field strength of spurious emission was measured in the following position: EUT stand-up position (Z axis), lie-down position (X, Y axis). The worst emission was found in lie-down position (X axis) and the worst case was recorded.



## 4. INSTRUMENT CALIBRATION

### 4.1 MEASURING INSTRUMENT CALIBRATION

The measuring equipment, which was utilized in performing the tests documented herein, has been calibrated in accordance with the manufacturer's recommendations for utilizing calibration equipment, which is traceable to recognized national standards.

### 4.2 MEASUREMENT EQUIPMENT USED

#### Equipment Used for Emissions Measurement

Conducted Emissions Test Site					
Name of Equipment	Manufacturer	Model	Serial Number	Calibration Date	Calibration Due
DC Power Supplies	GW Instek	SPS-3610	GPE880163	01/19/2016	01/18/2017
Power Meter	Anritsu	ML2495A	1012009	07/08/2015	07/07/2016
Power Sensor	Anritsu	MA2411B	917072	07/08/2015	07/07/2016
Signal Analyzer	R&S	FSV 40	101073	07/20/2015	07/19/2016
Spectrum Analyzer	Agilent	E4446A	US42510268	02/15/2016	02/14/2017
Thermostatic/Hrgrosatic Chamber	TAICHY	MHG-150LF	930619	10/08/2015	10/07/2016
Vector Signal Generator	R&S	SMU 200A	102239	03/10/2016	03/09/2017
AC Power Source	EXTECH	6205	1140845	N.C.R	N.C.R

Wugu 966 Chamber A					
Name of Equipment	Manufacturer	Model	Serial Number	Calibration Date	Calibration Due
Bilog Antenna	Sunol Sciences	JB3	A030105	08/06/2015	08/05/2016
EMI Test Receiver	R&S	ESCI	100064	06/04/2015	06/03/2016
Horn Antenna	EMCO	3117	55165	02/24/2016	02/23/2017
Horn Antenna	EMCO	3116	26370	01/15/2016	01/14/2017
K Type Cable	Huber+Suhner	SUCOFLEX 102	29406/2	01/12/2016	01/11/2017
K Type Cable	Huber+Suhner	SUCOFLEX 102	22470/2	01/12/2016	01/11/2017
Pre-Amplifier	MITEQ	AMF-6F-2604 00-40-8P	985646	01/14/2016	01/13/2017
Pre-Amplifier	EMCI	EMC 012635	980151	06/05/2015	06/04/2016
Pre-Amplifier	EMCI	EM330	N/A	06/05/2015	06/04/2016
Spectrum Analyzer	Agilent	E4446A	US42510252	12/08/2015	12/07/2016
Antenna Tower	CCS	CC-A-1F	N/A	N.C.R	N.C.R
Controller	CCS	CC-C-1F	N/A	N.C.R	N.C.R
Turn Table	CCS	CC-T-1F	N/A	N.C.R	N.C.R
Software	EZ-EMC (CCS-3A1RE)				

Conducted Emission Room # B					
Name of Equipment	Manufacturer	Model	Serial Number	Calibration Date	Calibration Due
EMI Test Receiver	R&S	ESCI	101073	09/09/2015	09/08/2016
LISN	SCHWARZBECK	NSLK 8127	8127-541	11/23/2015	11/22/2016
LISN	R&S	ENV216	101054	05/11/2016	05/10/2017
Capacitive Voltage Probe	FCC	F-CVP-1	100185	03/09/2016	03/08/2017
Software	CCS-3A1-CE				

**Remark:**

1. Each piece of equipment is scheduled for calibration once a year and Precision Dipole is scheduled for calibration once three years.
2. N.C.R. = No Calibration Request.

**4.3 MEASUREMENT UNCERTAINTY**

PARAMETER	UNCERTAINTY
Powerline Conducted Emission	+/- 1.2575
3M Semi Anechoic Chamber / 30M~200M	+/- 4.0138
3M Semi Anechoic Chamber / 200M~1000M	+/- 3.9483
3M Semi Anechoic Chamber / 1G~8G	+/- 2.5975
3M Semi Anechoic Chamber / 8G~18G	+/- 2.6112
3M Semi Anechoic Chamber / 18G~26G	+/- 2.7389
3M Semi Anechoic Chamber / 26G~40G	+/- 2.9683

**Remark:** This uncertainty represents an expanded uncertainty expressed at approximately the 95% confidence level using a coverage factor of  $k=2$ .

## 5. FACILITIES AND ACCREDITATIONS

### 5.1 FACILITIES

All measurement facilities used to collect the measurement data are located at

- No.199, Chunghsen Road, Hsintien City, Taipei Hsien, Taiwan, R.O.C.  
Tel: 886-2-2217-0894 / Fax: 886-2-2217-1029
- No.11, Wugong 6th Rd., Wugu Dist., New Taipei City 24891, Taiwan. (R.O.C.)  
Tel: 886-2-2299-9720 / Fax: 886-2-2298-4045
- No.81-1, Lane 210, Bade 2nd Rd., Lujhu Township, Taoyuan County 33841, TAIWAN, R.O.C.  
Tel: 886-3-324-0332 / Fax: 886-3-324-5235

The sites are constructed in conformance with the requirements of ANSI C63.7, ANSI C63.10: 2013 and CISPR Publication 22.

### 5.2 EQUIPMENT

Radiated emissions are measured with one or more of the following types of linearly polarized antennas: tuned dipole, biconical, log periodic, bi-log, ridged waveguide, horn and/or Loop. Spectrum analyzers with pre-selectors and quasi-peak detectors are used to perform radiated measurements.

Conducted emissions are measured with Line Impedance Stabilization Networks and EMI Test Receivers.



Calibrated wideband preamplifiers, coaxial cables, and coaxial attenuators are also used for making measurements.

All receiving equipment conforms to CISPR Publication 16-1, "Radio Interference Measuring Apparatus and Measurement Methods."

### 5.3 LABORATORY ACCREDITATIONS AND LISTING

The test facilities used to perform radiated and conducted emissions tests are accredited by American Association for Laboratory Accreditation Program for the specific scope accreditation under Lab Code: 0824-01 to perform Electromagnetic Interference tests according to FCC Part 15 and CISPR 22 requirements. In addition, the test facilities are listed with Industry Canada, Certification and Engineering Bureau, IC 2324G-1 for 3M Semi Anechoic Chamber A, 2324G-2 for 3M Semi Anechoic Chamber B.

**5.4 TABLE OF ACCREDITATIONS AND LISTINGS**

Country	Agency	Scope of Accreditation	Logo
USA	FCC	3M Semi Anechoic Chamber (FCC MRA: TW1039) to perform FCC Part 15 measurements	 FCC MRA: TW1039
Taiwan	TAF	LP0002, RTTE01, FCC Method-47 CFR Part 15 Subpart C, D, E, RSS-210, RSS-310 IDA TS SRD, AS/NZS 4268, AS/NZS 4771, TS 12.1 & 12.2, ETSI EN 300 440-1, ETSI EN 300 440-2, ETSI EN 300 328, ETSI EN 300 220-1, ETSI EN 300 220-2, ETSI EN 301 893, ETSI EN 301 489-1/3/7/17 FCC OET Bulletin 65 + Supplement C, EN 50360, EN 50361, EN 50371, RSS 102, EN 50383, EN 50385, EN 50392, IEC 62209, CNS 14958-1, CNS 14959 FCC Method -47 CFR Part 15 Subpart B IEC / EN 61000-3-2, IEC / EN 61000-3-3, IEC / EN 61000-4-2/3/4/5/6/8/11	
Canada	Industry Canada	3M Semi Anechoic Chamber (IC 2324G-1 / IC 2324G-2) to perform	 IC 2324G-1 IC 2324G-2

*\* No part of this report may be used to claim or imply product endorsement by A2LA or any agency of the US Government.*

## 6. SETUP OF EQUIPMENT UNDER TEST

### 6.1 SETUP CONFIGURATION OF EUT

See test photographs attached in Appendix II for the actual connections between EUT and support equipment.

### 6.2 SUPPORT EQUIPMENT

No	Equipment	Brand	Model	Series No.	FCC ID	Data Cable	Power Cord
	N/A						

**Remark:**

1. *All the equipment/cables were placed in the worst-case configuration to maximize the emission during the test.*
2. *Grounding was established in accordance with the manufacturer's requirements and conditions for the intended use.*

## 7. FCC PART 15.247 REQUIREMENTS & RSS-247 REQUIREMENTS

### 7.1 99% BANDWIDTH

#### Test Configuration

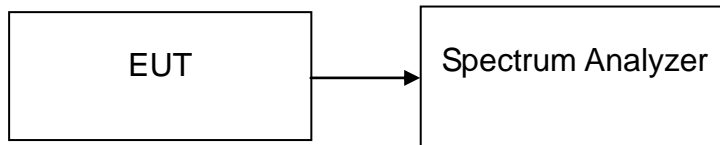

#### TEST PROCEDURE

The resolution bandwidth shall be set to as close to 1% of the selected span as is possible without being below 1%. The video bandwidth shall be set to 3 times the resolution bandwidth. Video averaging is not permitted. Where practical, a sampling detector shall be used since a peak or, peak hold.

**Test Data****IEEE 802.11b mode**

Channel	Frequency (MHz)	99% Bandwidth (MHz)
Low	2412	15.1519
Mid	2437	15.2821
High	2462	15.0217

**IEEE 802.11g mode**

Channel	Frequency (MHz)	99% Bandwidth (MHz)
Low	2412	16.4544
Mid	2437	16.4544
High	2462	16.4978

**IEEE 802.11n HT 20 MHz mode**

Channel	Frequency (MHz)	99% Bandwidth (MHz)
Low	2412	17.6266
Mid	2437	17.6266
High	2462	17.6266

**IEEE 802.11n HT 40 MHz mode**

Channel	Frequency (MHz)	99% Bandwidth (MHz)
Low	2422	36.1215
Mid	2437	36.1215
High	2452	36.1215

**Test Plot**

**IEEE 802.11b mode**

**99% Bandwidth (CH Low)**

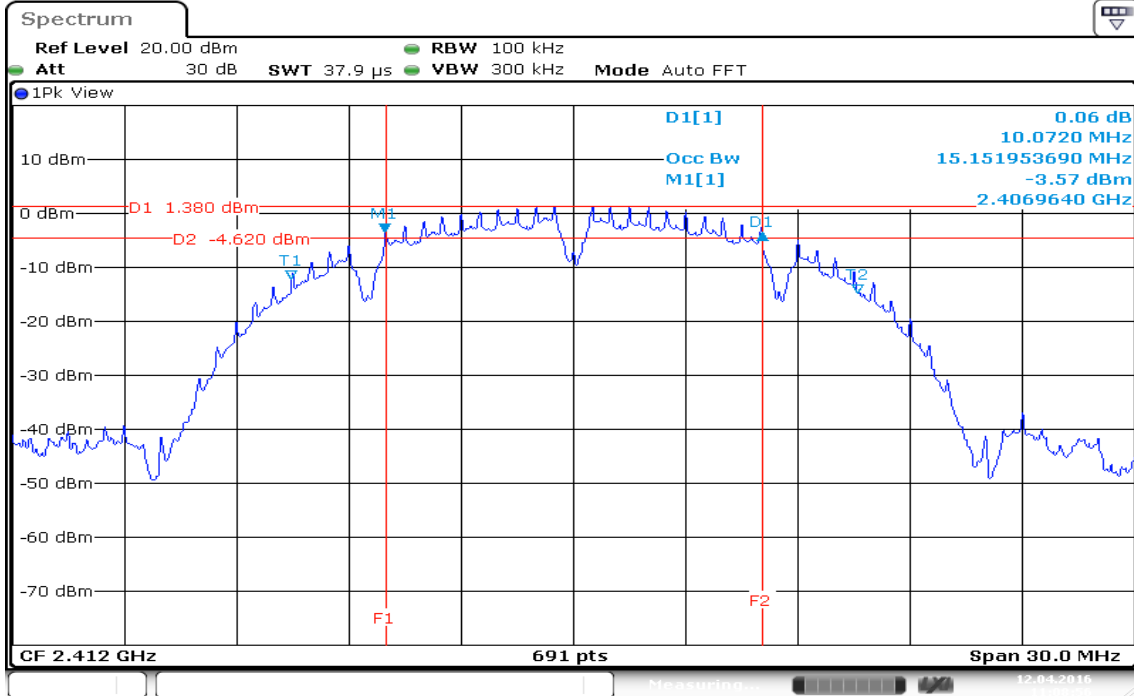

Date: 12.APR.2016 11:08:55

**99% Bandwidth (CH Mid)**

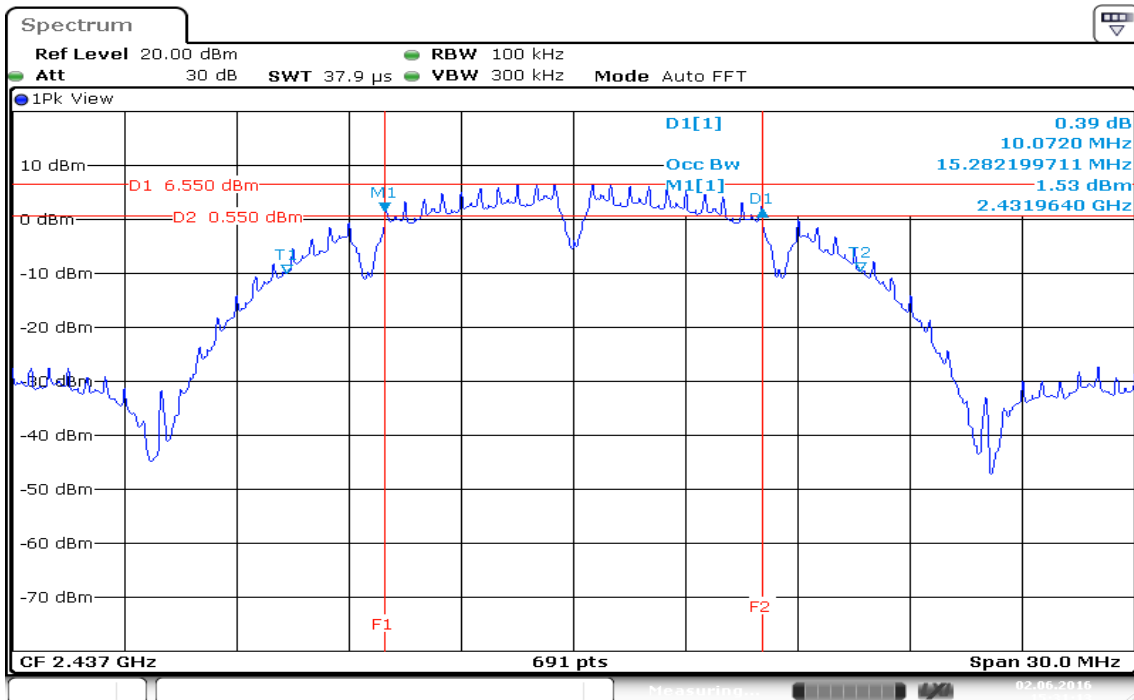

Date: 2.JUN.2016 15:31:13



### 99% Bandwidth (CH High)

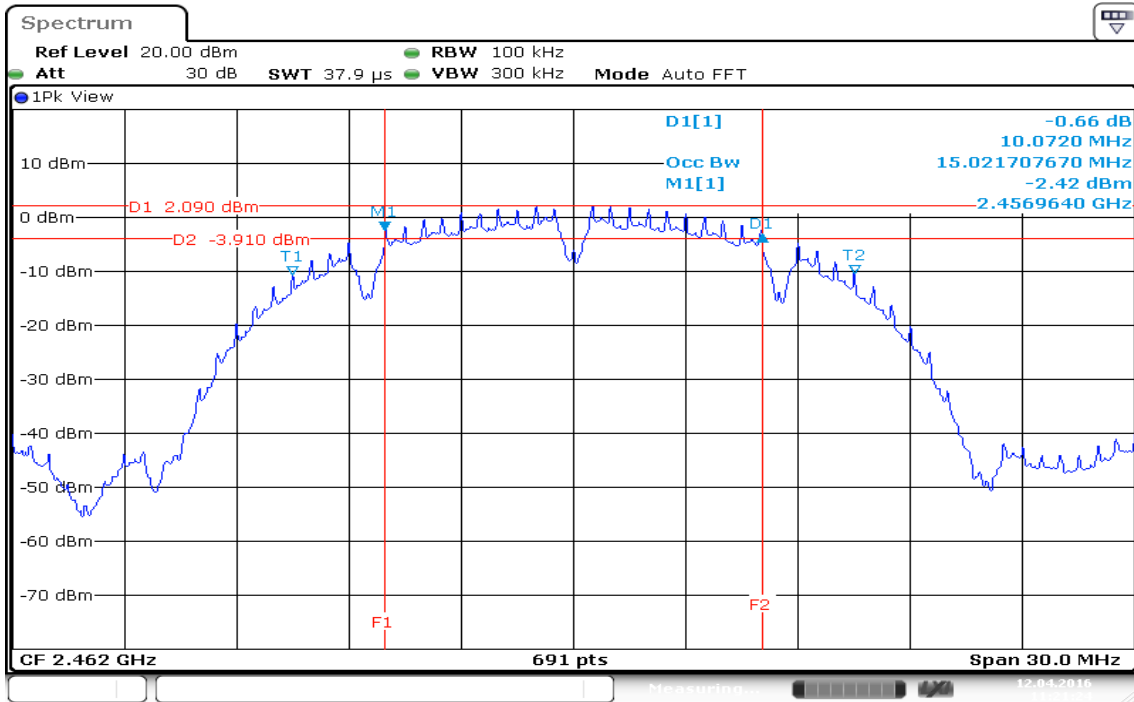

Date: 12.APR.2016 11:21:24

**IEEE 802.11g mode**

**99% Bandwidth (CH Low)**

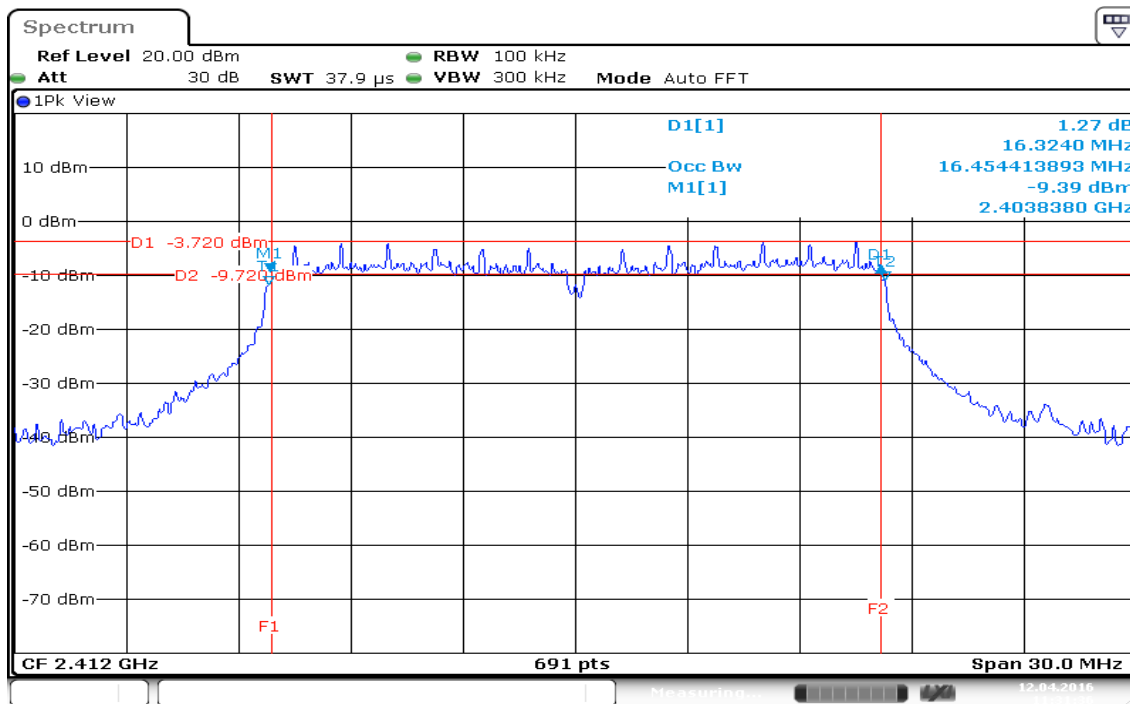

**99% Bandwidth (CH Mid)**

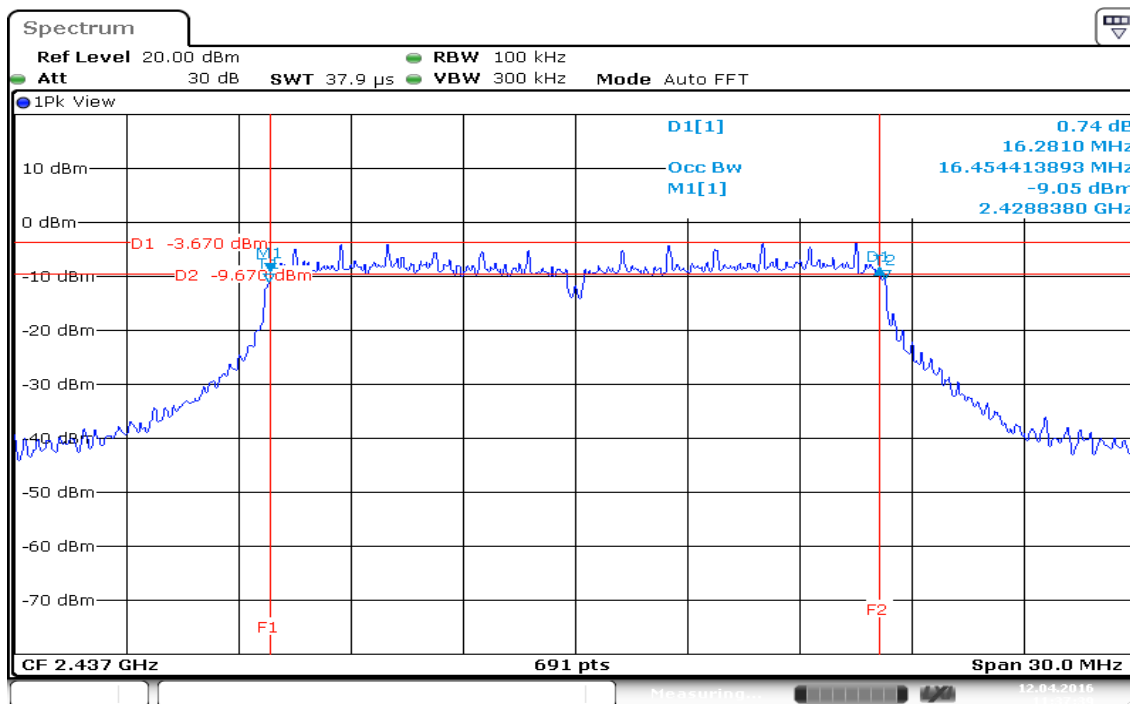

### 99% Bandwidth (CH High)

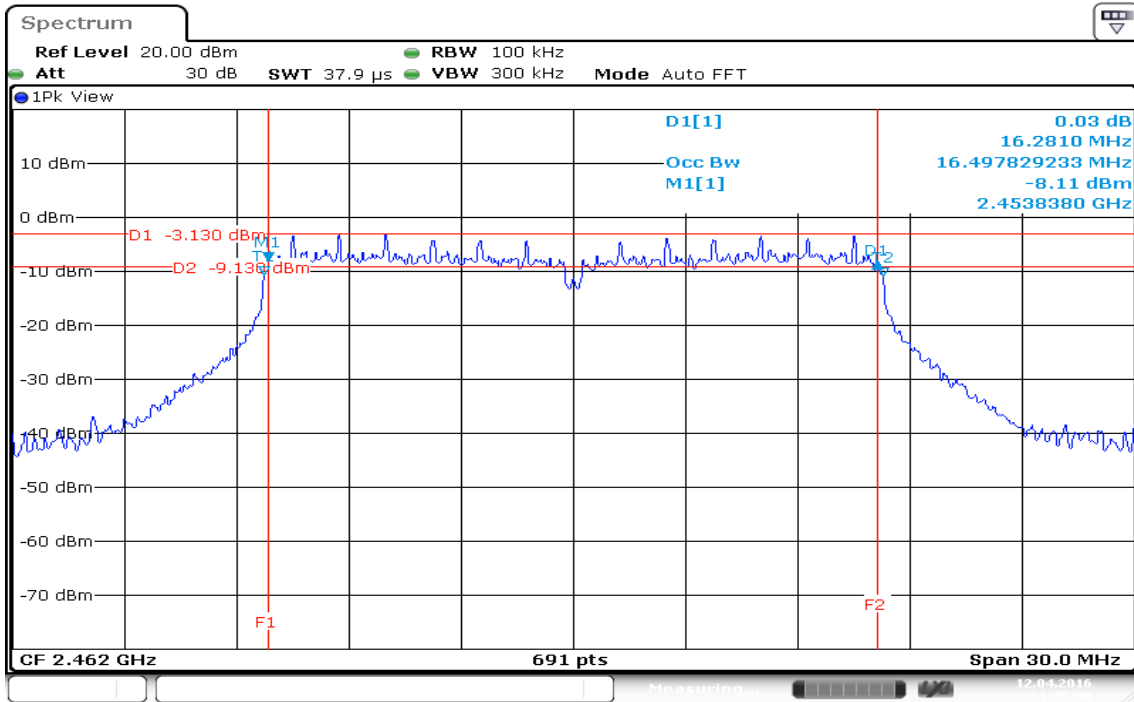

Date: 12.APR.2016 11:45:00

**IEEE 802.11n HT 20 MHz mode**

**99% Bandwidth (CH Low)**

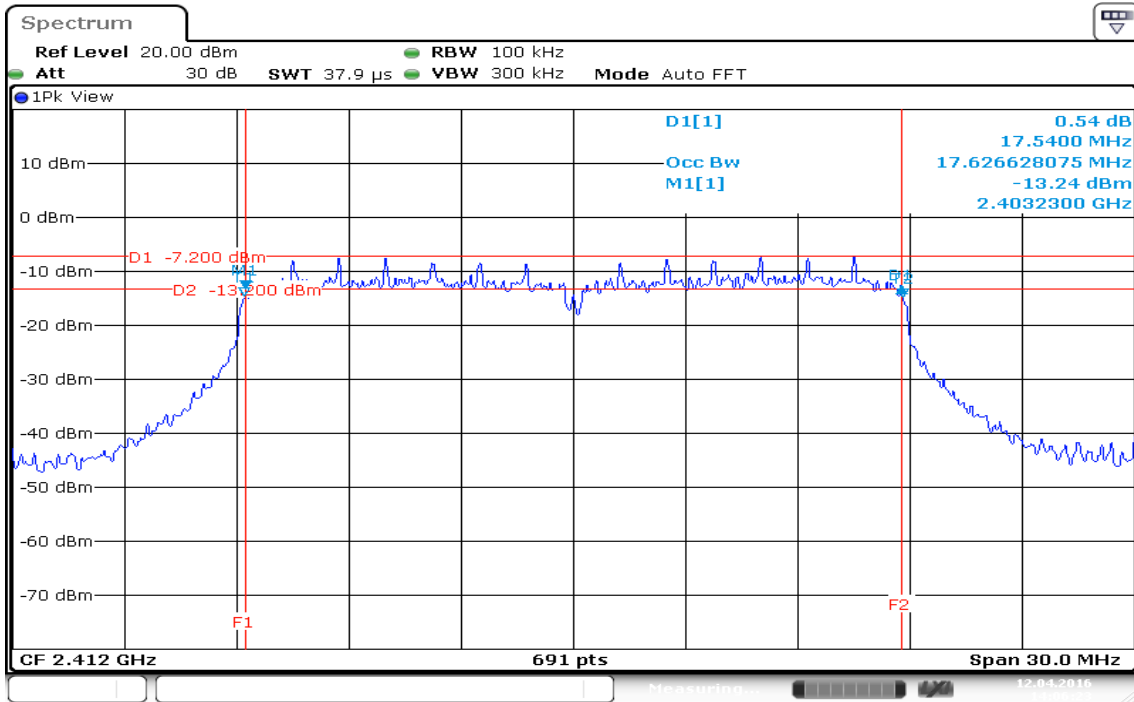

**99% Bandwidth (CH Mid)**

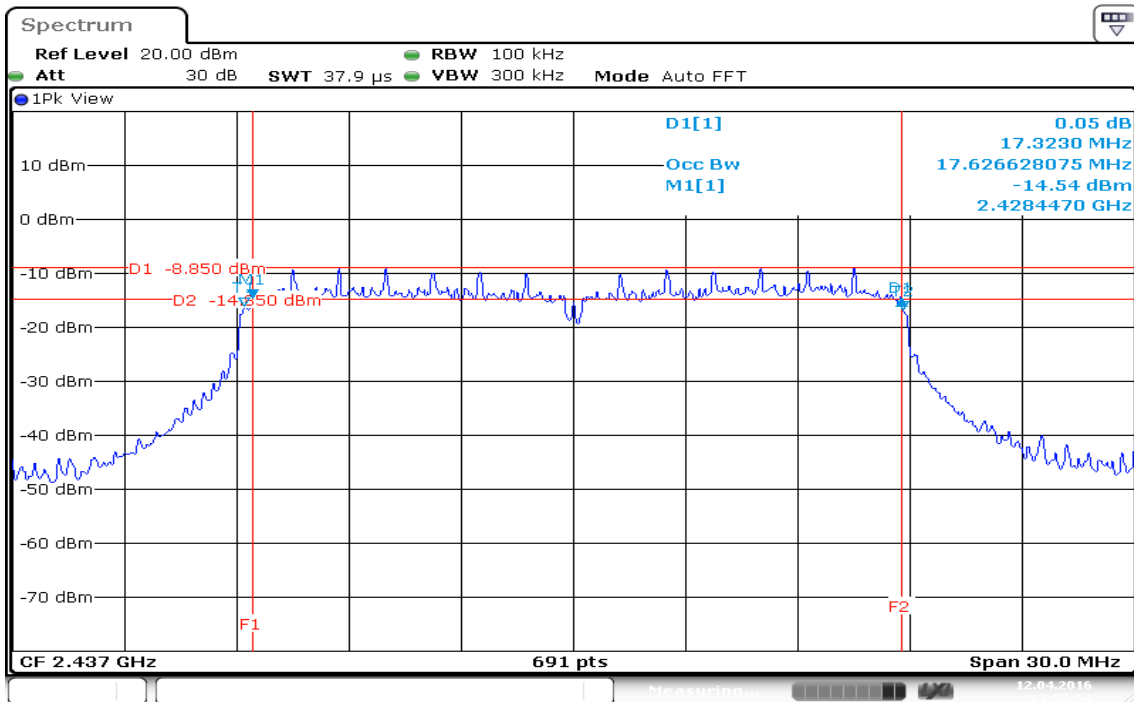

### 99% Bandwidth (CH High)

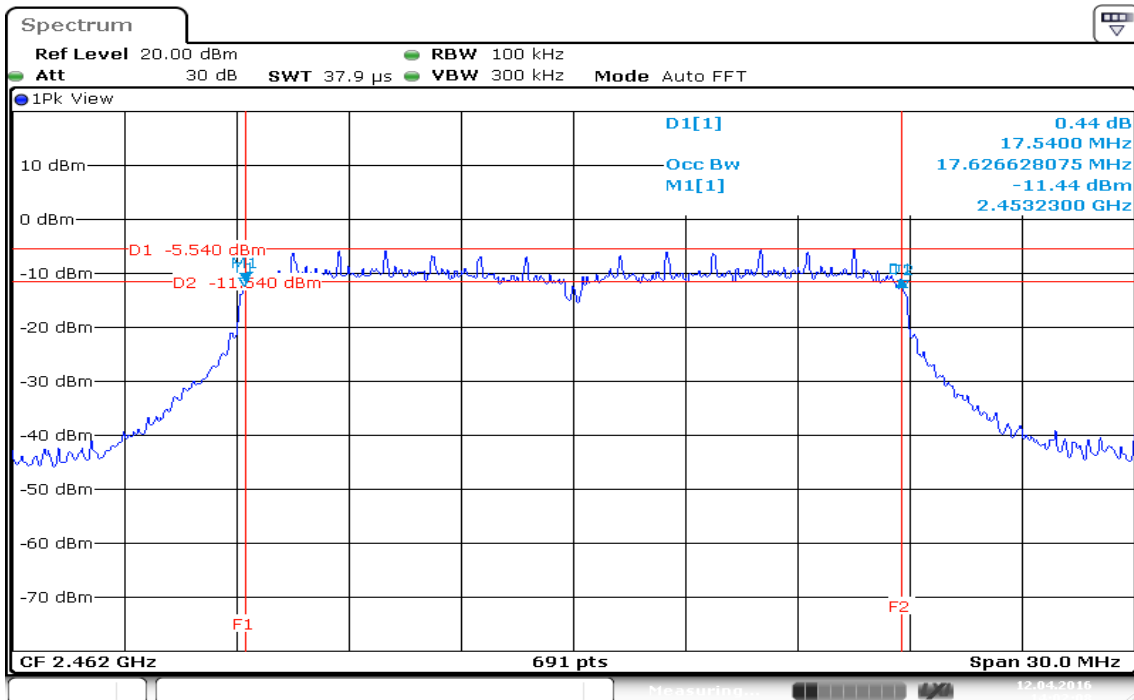

Date: 12.APR.2016 14:02:08

### IEEE 802.11n HT 40 MHz mode

### 99% Bandwidth (CH Low)

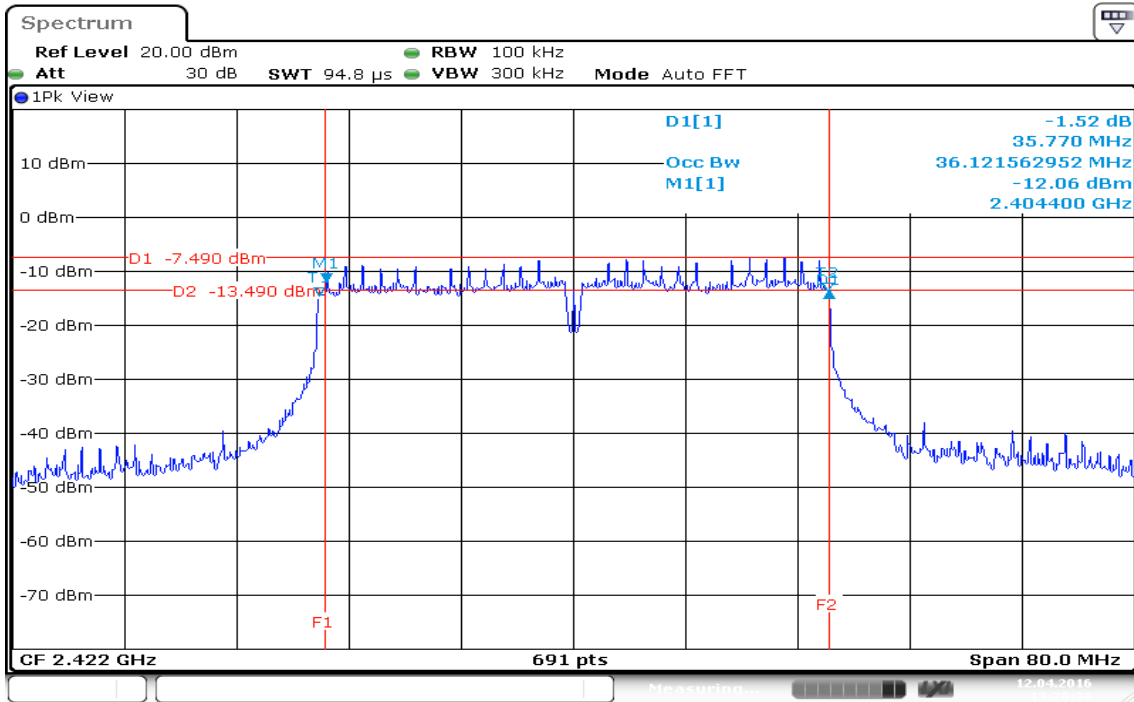

### 99% Bandwidth (CH Mid)

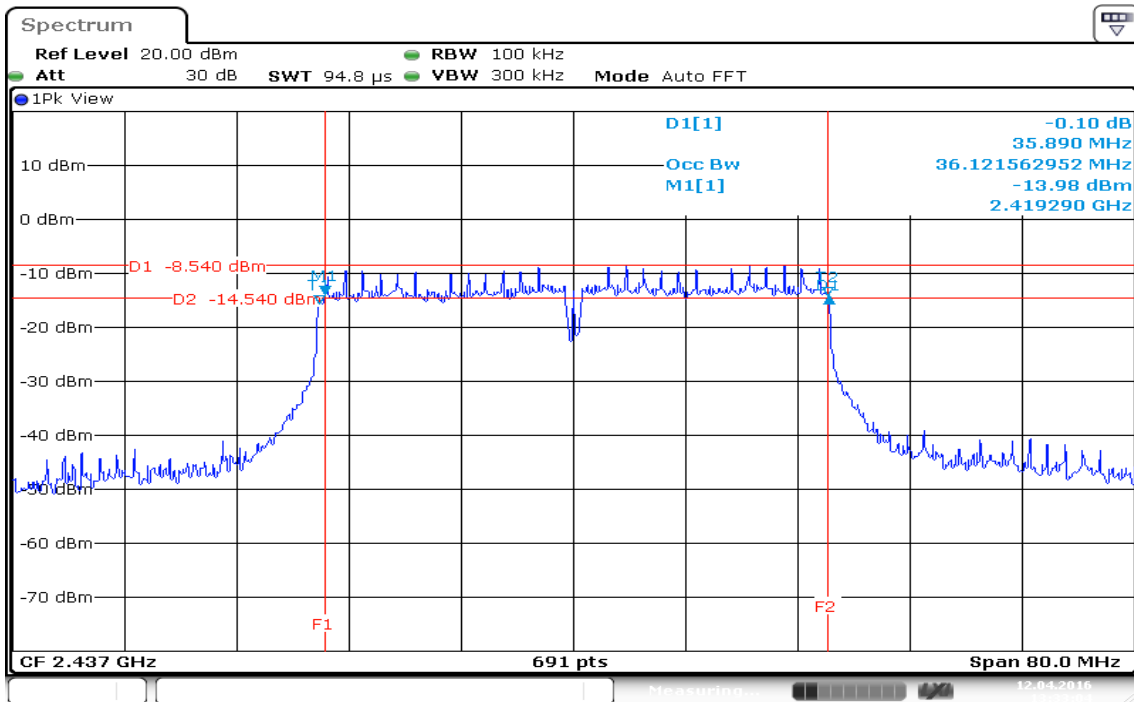

### 99% Bandwidth (CH High)

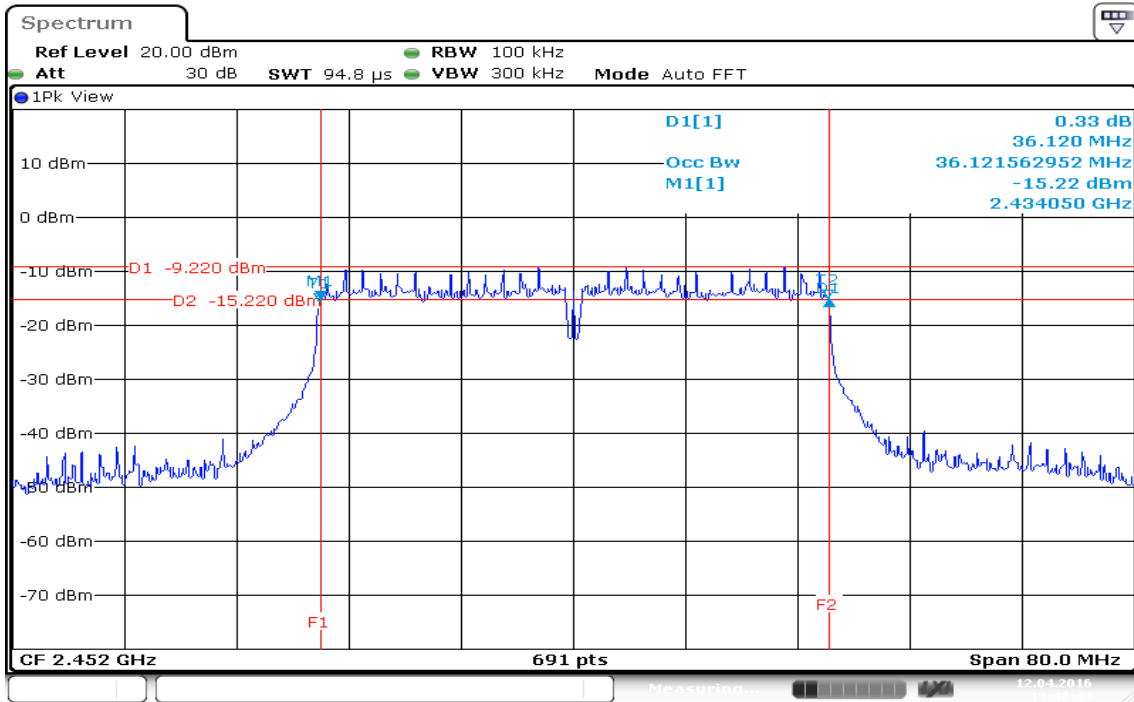

Date: 12.APR.2016 13:42:44

## 7.2 6DB BANDWIDTH

### LIMIT

According to §15.247(a)(2) & RSS-247, systems using digital modulation techniques may operate in the 902 - 928 MHz, 2400 - 2483.5 MHz, and 5725 - 5850 MHz bands. The minimum 6dB bandwidth shall be at least 500 kHz.

### Test Configuration

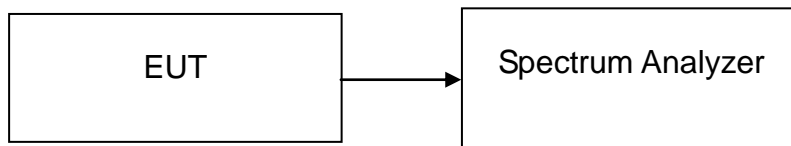

### TEST PROCEDURE

1. Place the EUT on the table and set it in the transmitting mode.
2. Remove the antenna from the EUT and then connect a low loss RF cable from the antenna port to the spectrum analyzer.
3. Set the spectrum analyzer as RBW = 100 kHz, VBW= 300kHz, Span = 50 MHz, Sweep = auto.
4. Mark the peak frequency and -6dB (upper and lower) frequency.
5. Repeat until all the rest channels are investigated.

### TEST RESULTS

*No non-compliance noted*



**Test Data**

**IEEE 802.11b mode**

Channel	Frequency (MHz)	6dB Bandwidth (MHz)	Limit (kHz)	Result
Low	2412	10.0720	>500	PASS
Mid	2437	10.0720		PASS
High	2462	10.0720		PASS

**IEEE 802.11g mode**

Channel	Frequency (MHz)	6dB Bandwidth (MHz)	Limit (kHz)	Result
Low	2412	16.3240	>500	PASS
Mid	2437	16.2810		PASS
High	2462	16.2810		PASS

**IEEE 802.11n HT 20 MHz mode**

Channel	Frequency (MHz)	6dB Bandwidth (MHz)	Limit (kHz)	Result
Low	2412	17.5400	>500	PASS
Mid	2437	17.3230		PASS
High	2462	17.5400		PASS

**IEEE 802.11n HT 40 MHz mode**

Channel	Frequency (MHz)	6dB Bandwidth (MHz)	Limit (kHz)	Result
Low	2422	35.770	>500	PASS
Mid	2437	35.890		PASS
High	2452	36.120		PASS

**Test Plot**

**IEEE 802.11b mode**

**6dB Bandwidth (CH Low)**

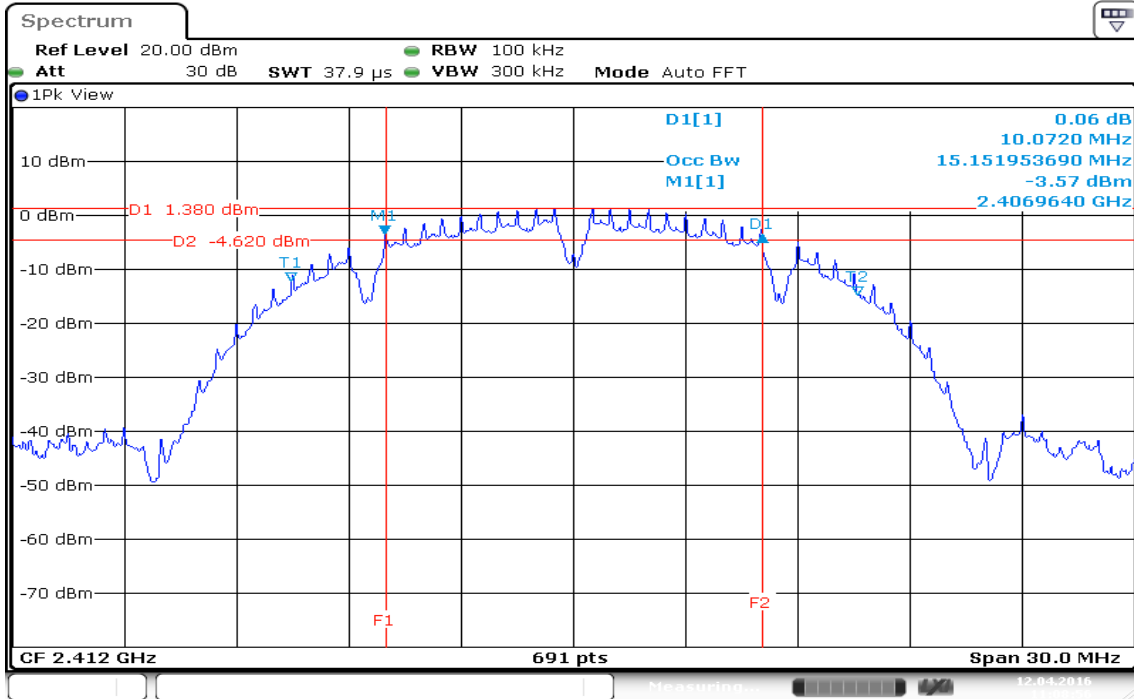

**6dB Bandwidth (CH Mid)**

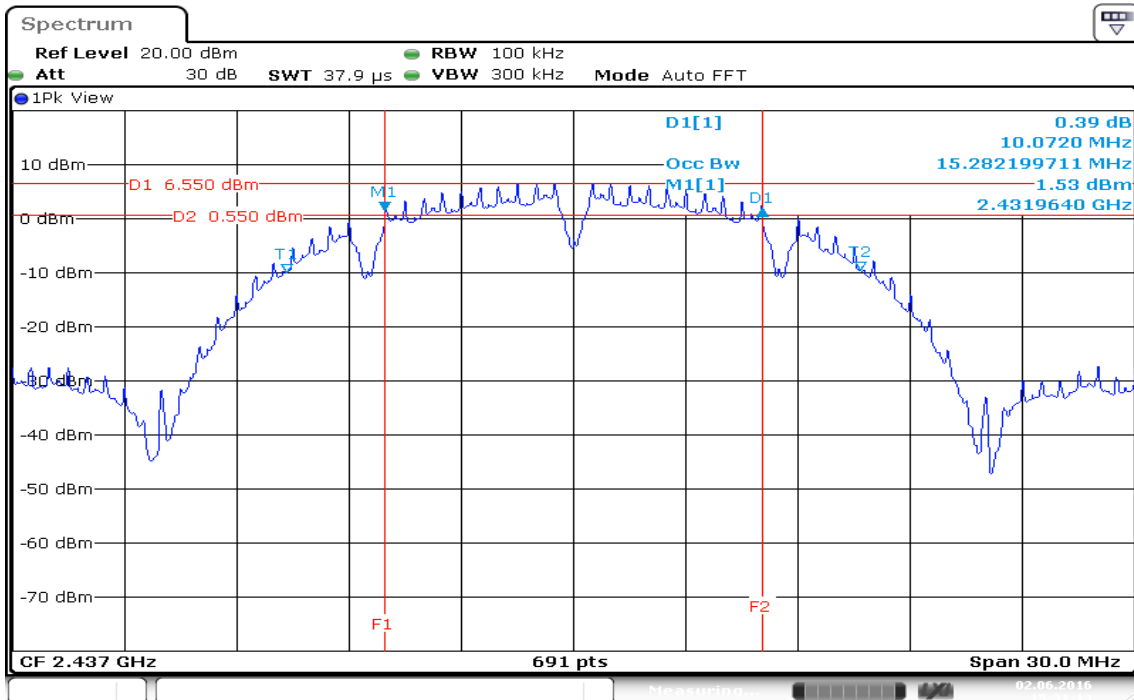

### 6dB Bandwidth (CH High)

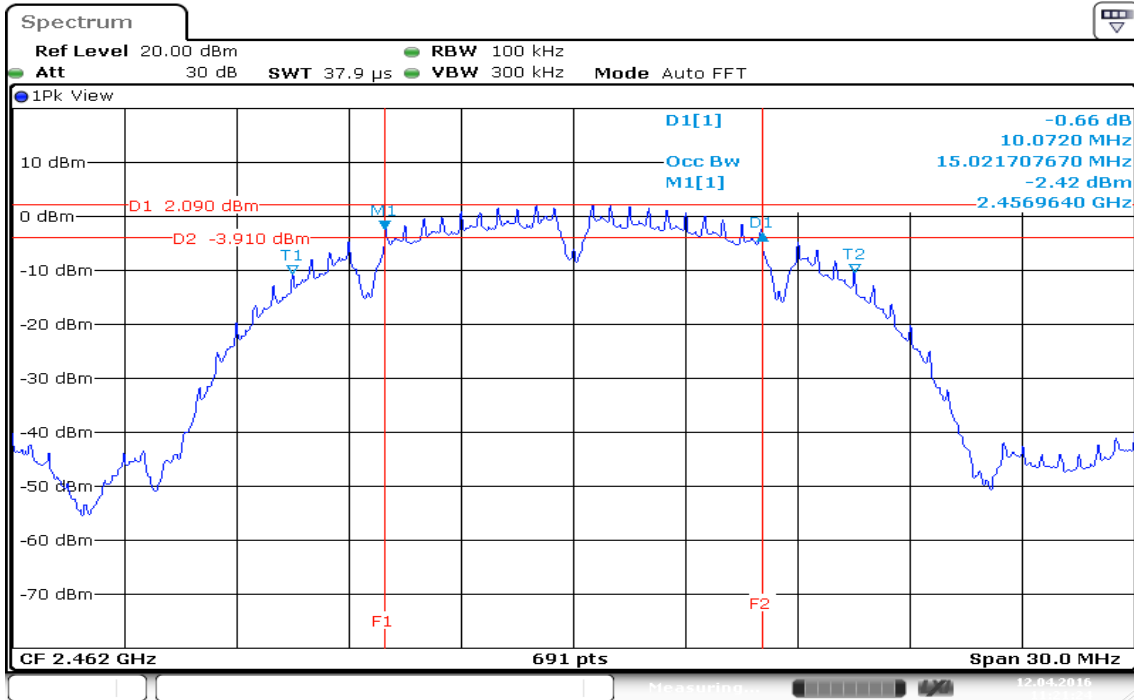

### IEEE 802.11g mode

### 6dB Bandwidth (CH Low)

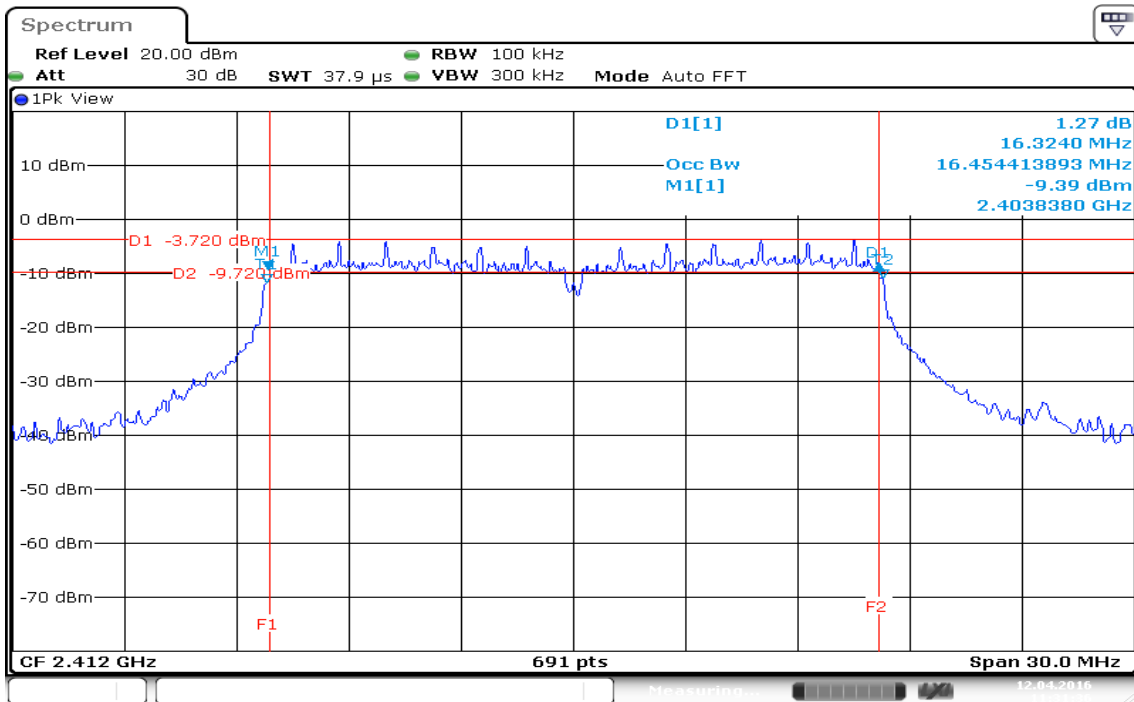

### 6dB Bandwidth (CH Mid)

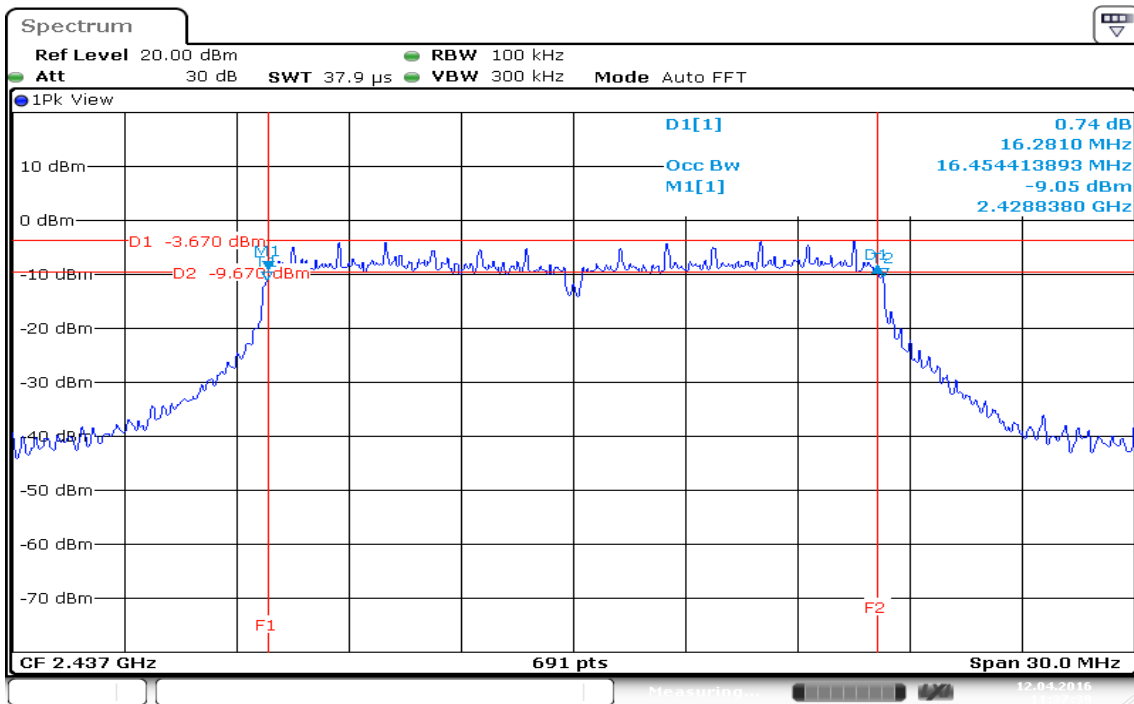

### 6dB Bandwidth (CH High)

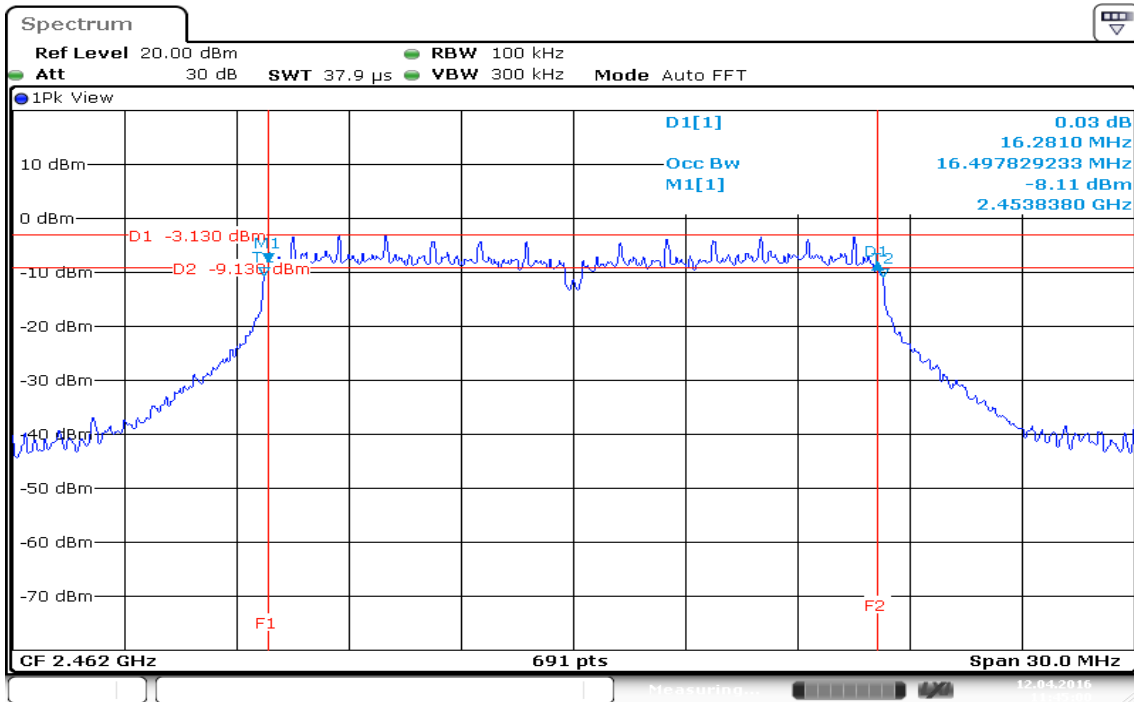

Date: 12.APR.2016 11:45:00

**IEEE 802.11n HT 20 MHz mode**

**6dB Bandwidth (CH Low)**

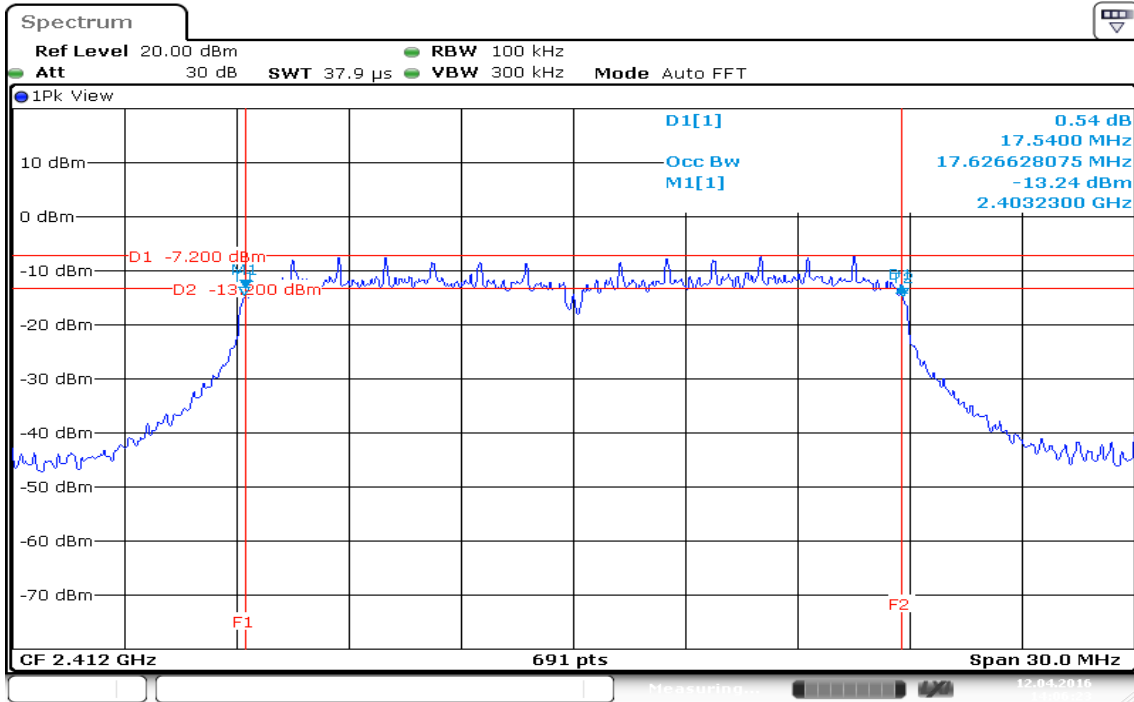

Date: 12.APR.2016 14:06:22

**6dB Bandwidth (CH Mid)**

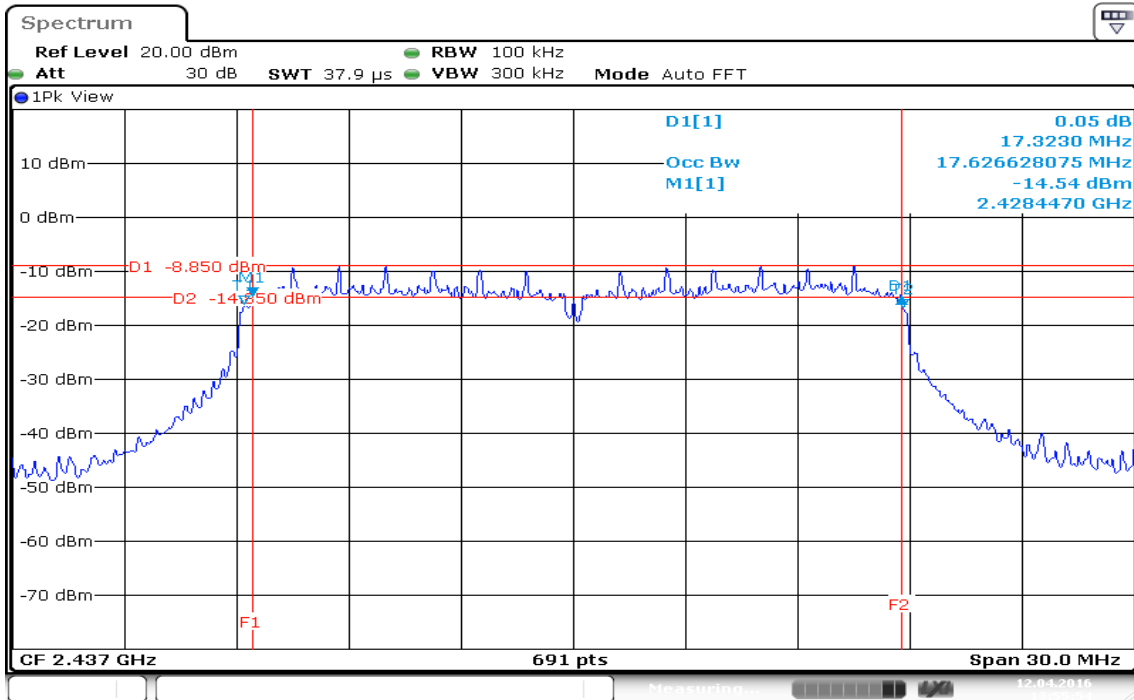

Date: 12.APR.2016 13:55:53

### 6dB Bandwidth (CH High)

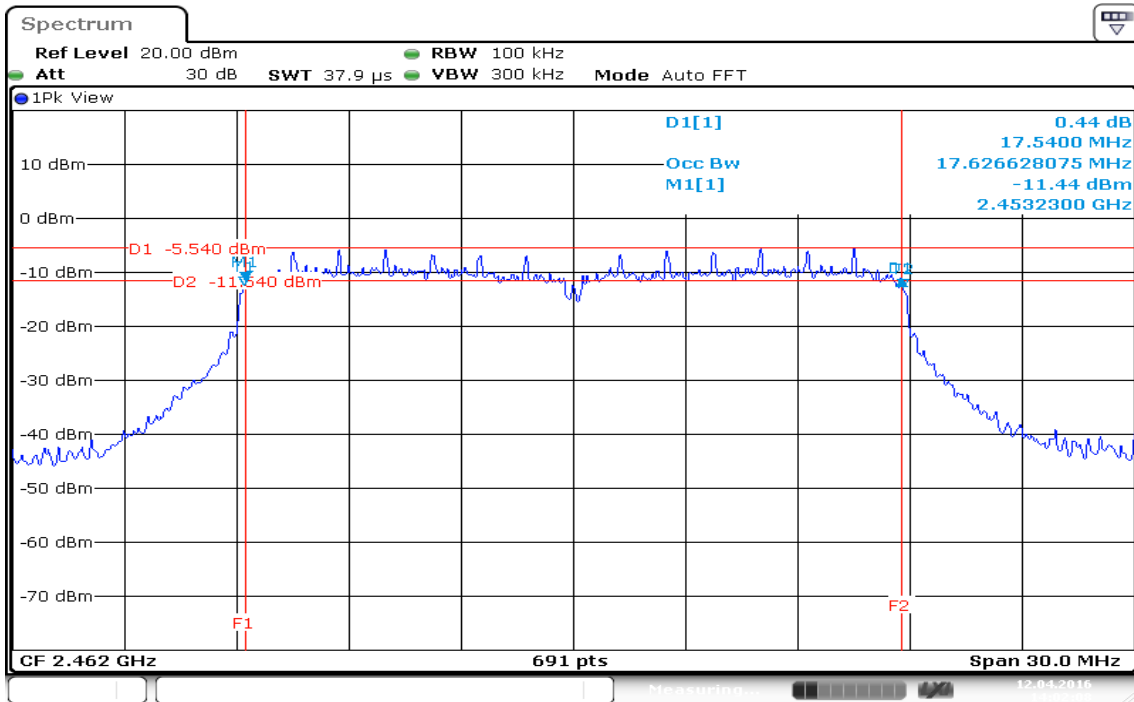

Date: 12.APR.2016 14:02:08

**IEEE 802.11n HT 40 MHz mode**

**6dB Bandwidth (CH Low)**

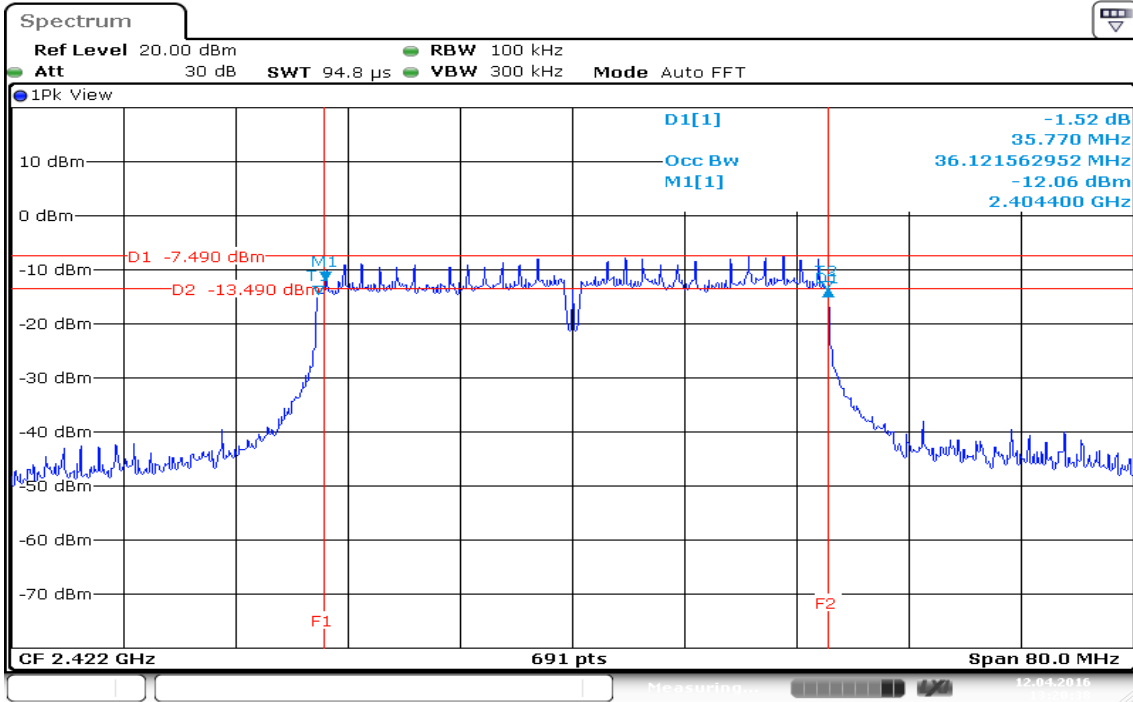

**6dB Bandwidth (CH Mid)**

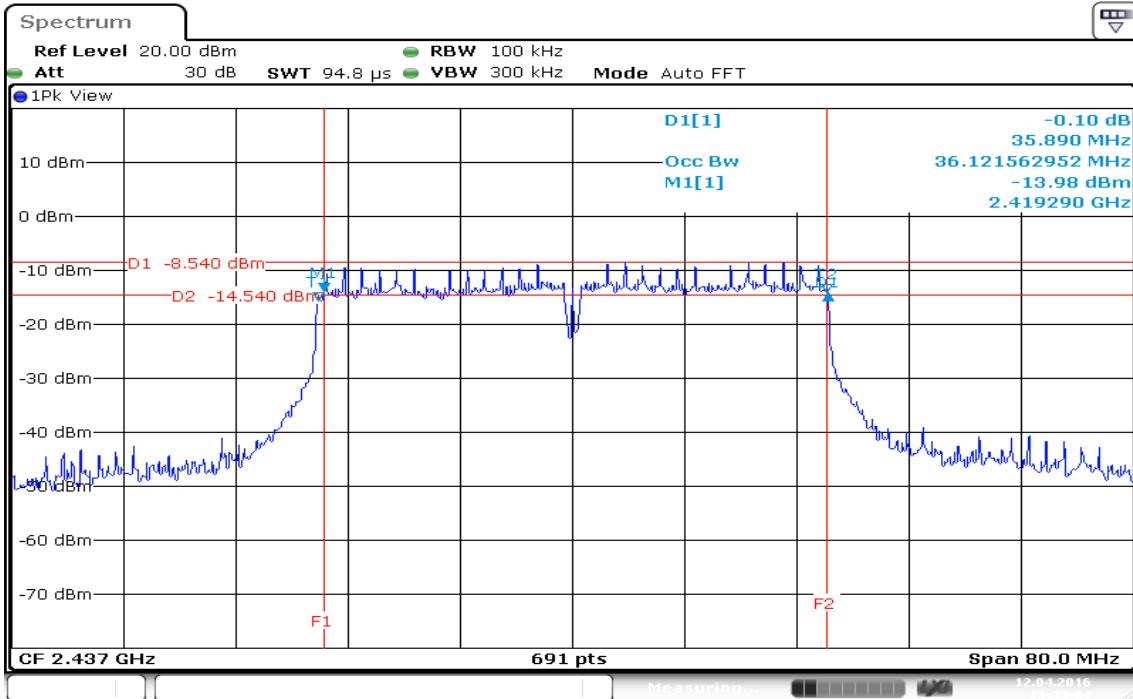



### 6dB Bandwidth (CH High)

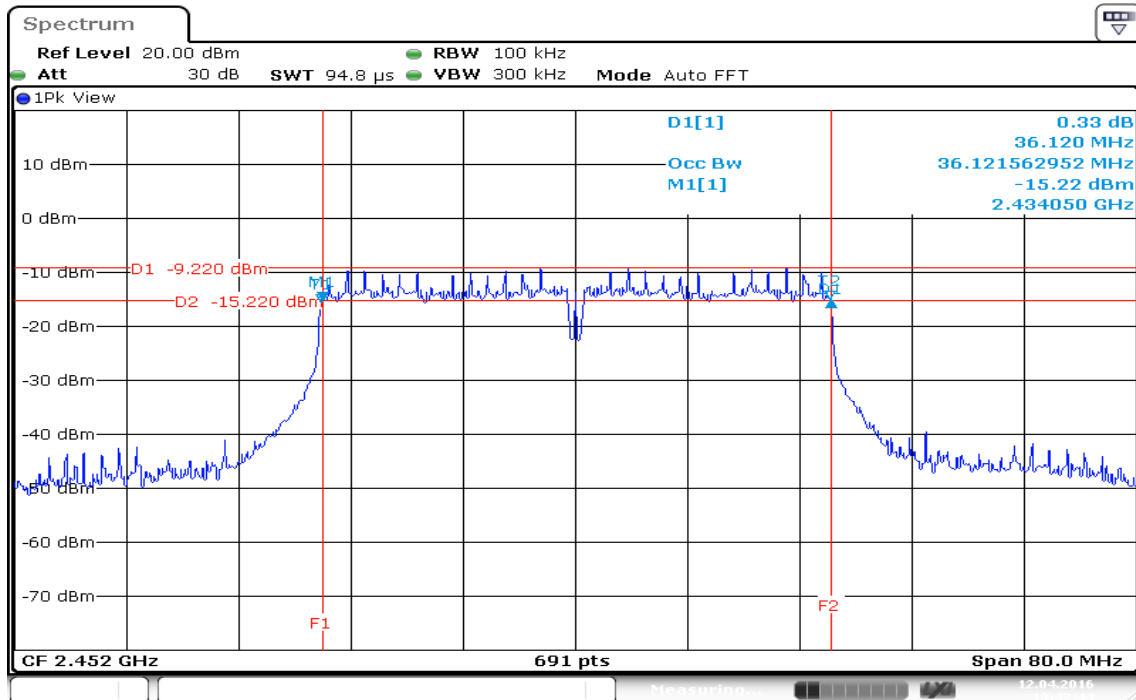

Date: 12.APR.2016 13:42:44

## 7.3 PEAK POWER

### LIMIT

The maximum peak output power of the intentional radiator shall not exceed the following:

1. According to §15.247(b)(3), for systems using digital modulation in the bands of 902-928 MHz, 2400-2483.5 MHz, and 5725-5850 MHz: 1 Watt.
2. According to §15.247(b)(4), the conducted output power limit specified in paragraph (b) of this section is based on the use of antennas with directional gains that do not exceed 6 dBi. Except as shown in paragraph (c) of this section, if transmitting antennas of directional gain greater than 6 dBi are used, the conducted output power from the intentional radiator shall be reduced below the stated values in paragraphs (b)(1), (b)(2), and (b)(3) of this section, as appropriate, by the amount in dB that the directional gain of the antenna exceeds 6 dBi.
3. According to RSS-247, for systems employing digital modulation techniques operating in the bands 902-928 MHz, 2400-2483.5 MHz and 5725-5850 MHz, the maximum peak conducted output power shall not exceed 1 W.

### Test Configuration

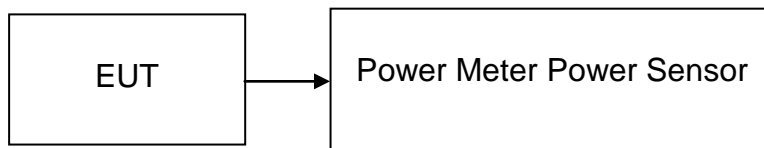

### TEST PROCEDURE

The transmitter output is connected to the Power Meter. The Power Meter is set to the peak power detection.

### TEST RESULTS

*No non-compliance noted*

**Test Data**

**IEEE 802.11b mode**

Channel	Frequency (MHz)	Output Power (dBm)	Output Power (W)	Limit (dBm)	Result
Low	2412	18.61	0.0726	30	PASS
Mid	2437	<b>*18.74</b>	0.0748		PASS
High	2462	18.72	0.0745		PASS

**IEEE 802.11g mode**

Channel	Frequency (MHz)	Output Power (dBm)	Output Power (W)	Limit (dBm)	Result
Low	2412	21.68	0.1472	30	PASS
Mid	2437	21.84	0.1528		PASS
High	2462	<b>*22.83</b>	0.1919		PASS

**IEEE 802.11n HT 20 MHz mode**

Channel	Frequency (MHz)	Output Power (dBm)	Output Power (W)	Limit (dBm)	Result
Low	2412	21.04	0.1271	30	PASS
Mid	2437	21.57	0.1435		PASS
High	2462	<b>*22.47</b>	0.1766		PASS

**IEEE 802.11n HT 40 MHz mode**

Channel	Frequency (MHz)	Output Power (dBm)	Output Power (W)	Limit (dBm)	Result
Low	2422	21.54	0.1426	30	PASS
Mid	2437	21.56	0.1432		PASS
High	2452	<b>*22.34</b>	0.1714		PASS

## 7.4 AVERAGE POWER

### LIMIT

None; for reporting purposes only.

### Test Configuration

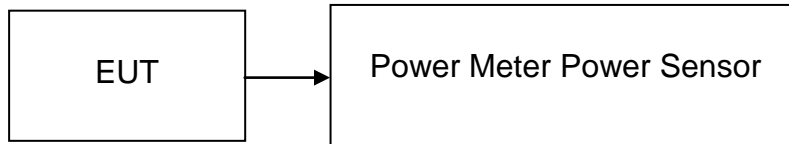

### TEST PROCEDURE

The transmitter output is connected to the Power Meter. The Power Meter is set to the peak power detection.

### TEST RESULTS

*No non-compliance noted*

**Test Data****Test mode: IEEE 802.11b mode**

Channel	Frequency (MHz)	Output Power (dBm)	Output Power (W)
Low	2412	<b>*16.21</b>	0.0418
Mid	2437	16.16	0.0413
High	2462	16.17	0.0414

**Test mode: IEEE 802.11g mode**

Channel	Frequency (MHz)	Output Power (dBm)	Output Power (W)
Low	2412	13.38	0.0218
Mid	2437	<b>*13.50</b>	0.0224
High	2462	13.20	0.0209

**Test mode: IEEE 802.11n HT 20 MHz mode**

Channel	Frequency (MHz)	Output Power (dBm)	Output Power (W)
Low	2412	12.40	0.0174
Mid	2437	<b>*12.49</b>	0.0177
High	2462	12.48	0.0177

**Test mode: IEEE 802.11n HT 40 MHz mode**

Channel	Frequency (MHz)	Output Power (dBm)	Output Power (W)
Low	2422	<b>*12.44</b>	0.0175
Mid	2437	12.10	0.0162
High	2452	12.11	0.0163

## 7.5 BAND EDGES MEASUREMENT

### LIMIT

According to §15.247(d) & RSS-247, in any 100 kHz bandwidth outside the frequency bands in which the spread spectrum intentional radiator is operating, the radio frequency power that is produced by the intentional radiator shall be at least 20 dB below that in the 100 kHz bandwidth within the band that contains the highest level of the desired power, based on either an RF conducted or a radiated measurement, provided the transmitter demonstrates compliance with the peak conducted power limits. In addition, radiated emissions which fall in the restricted bands, as defined in §15.205(a), must also comply with the radiated emission limits specified in 15.209(a) (see Section 15.205(c)).

### Test Configuration

#### For Radiated

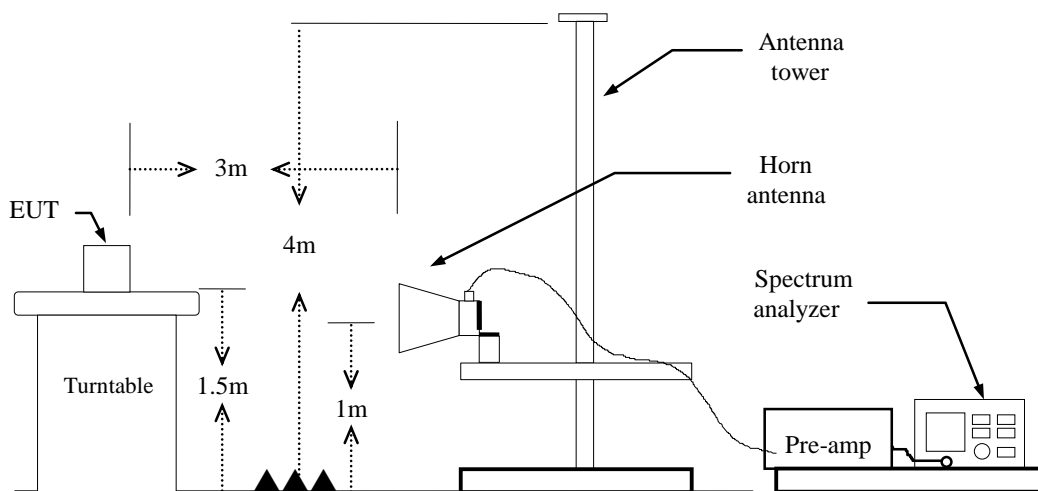

## **TEST PROCEDURE**

### **For Radiated**

1. The EUT is placed on a turntable, which is 1.5m above the ground plane.
2. The turntable shall be rotated for 360 degrees to determine the position of maximum emission level.
3. EUT is set 3m away from the receiving antenna, which is varied from 1m to 4m to find out the highest emission.
4. Set the spectrum analyzer in the following setting in order to capture the lower and upper band-edges of the emission:
  - (a) PEAK: RBW=1MHz / VBW=3MHz / Sweep=AUTO
  - (b) AVERAGE: RBW=1MHz,  
if duty cycle  $\geq 98\%$ , VBW=10Hz.  
if duty cycle  $< 98\%$  VBW=1/T.  
**IEEE 802.11b mode:**  $\geq 98\%$ , VBW=10Hz  
**IEEE 802.11g mode:**  $\approx 96\%$ , VBW=510Hz  
**IEEE 802.11n HT 20 MHz mode:**  $\geq 98\%$ , VBW=10Hz  
**IEEE 802.11n HT 40 MHz mode:**  $\geq 98\%$ , VBW=10Hz
5. Repeat the procedures until all the PEAK and AVERAGE versus POLARIZATION are measured.
6. Result = Spectrum Reading + cable loss(spectrum to Amp) - Amp Gain + Cable loss(Amp to receive Ant)+ Receive Ant

### **For Un-restricted Band Emissions**

The peak output power procedure is used to measure the fundamental emission power to demonstrate compliance to requirements, then the peak conducted output power measured within any 100 kHz outside the authorized frequency band shall be attenuated by at least 20 dB relative to the maximum measured in-band peak PSD level.

## **TEST RESULTS**

Refer to attach spectrum analyzer data chart.

**Band Edges**

**IEEE 802.11b Mode / CH Low**

**Detector mode: Peak**



No.	Frequency (MHz)	Reading (dBuV)	Correct Factor(dB)	Result (dBuV)	Limit (dBuV)	Margin (dB)	Remark
1	2386.608	60.53	-2.52	58.01	74.00	-15.99	peak
2	2412.032	108.64	-2.42	106.22	74.00	32.22	peak



**Detector mode: Average**



No.	Frequency (MHz)	Reading (dBuV)	Correct Factor(dB)	Result (dBuV)	Limit (dBuV)	Margin (dB)	Remark
1	2386.160	53.89	-2.52	51.37	54.00	-2.63	AVG
2	2411.248	104.17	-2.42	101.75	54.00	47.75	AVG

## Band Edges

IEEE 802.11b Mode / CH Mid

Detector mode: Peak

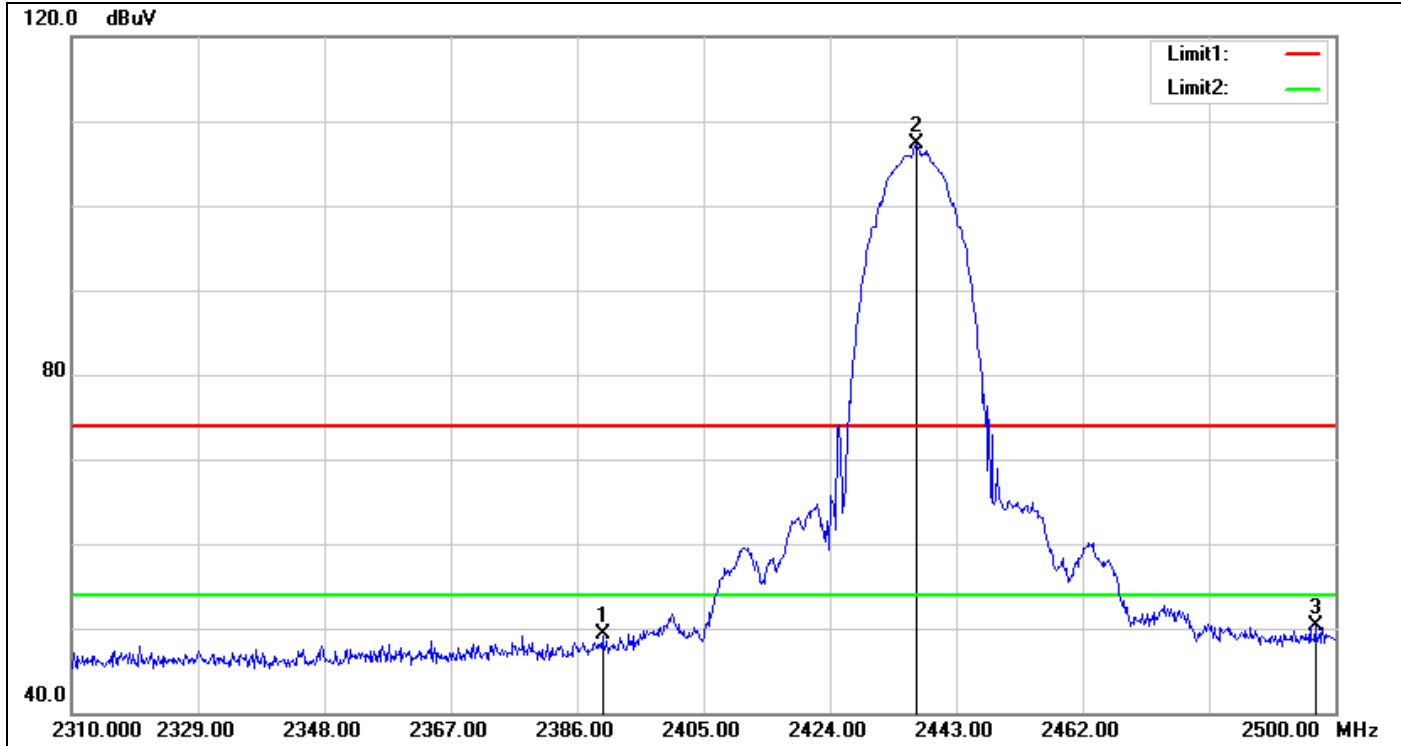

No.	Frequency (MHz)	Reading (dBuV)	Correct Factor(dB)	Result (dBuV)	Limit (dBuV)	Margin (dB)	Remark
1	2389.800	51.69	-2.49	49.20	74.00	-24.80	peak
2	2436.920	109.51	-2.23	107.28	74.00	33.28	peak
3	2496.960	52.13	-1.88	50.25	74.00	-23.75	peak

**Detector mode: Average**

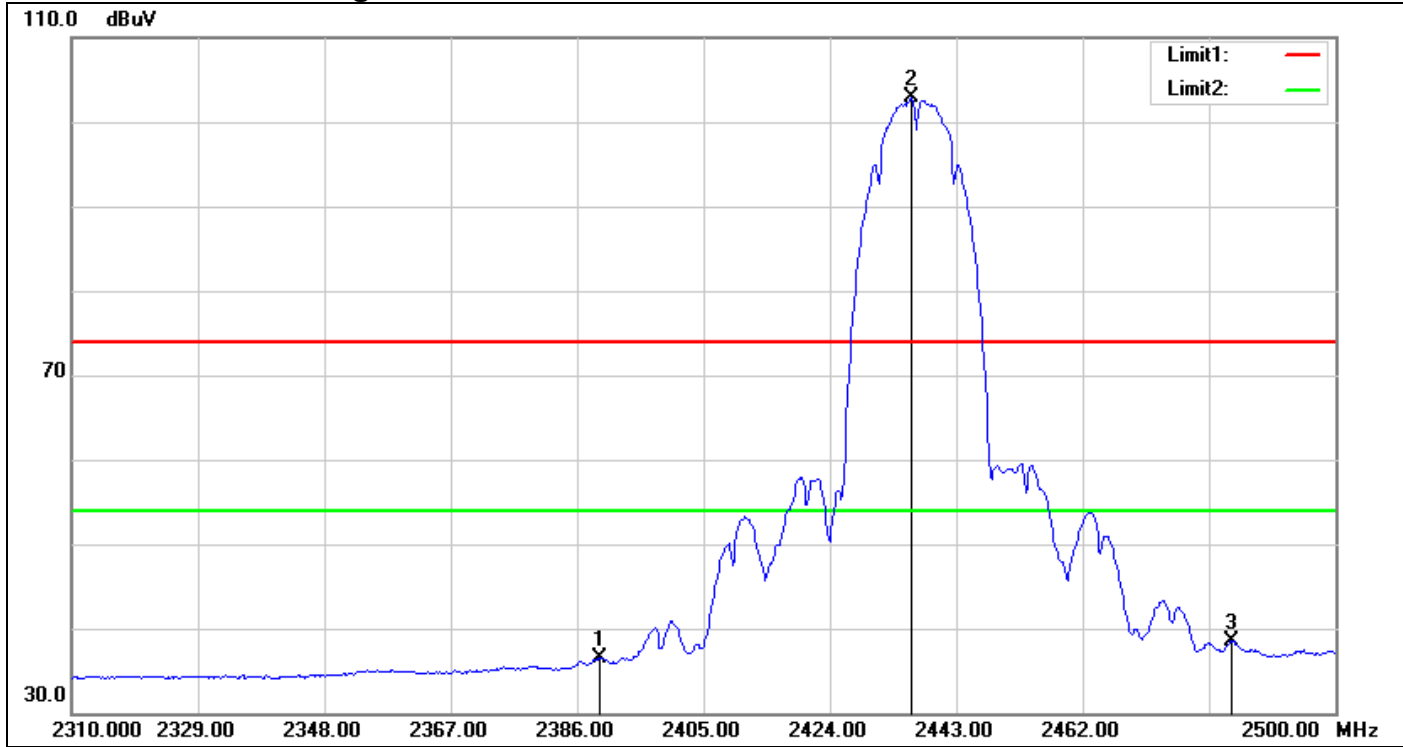

No.	Frequency (MHz)	Reading (dBuV)	Correct Factor(dB)	Result (dBuV)	Limit (dBuV)	Margin (dB)	Remark
1	2389.420	39.06	-2.50	36.56	54.00	-17.44	AVG
2	2436.160	105.07	-2.24	102.83	54.00	48.83	AVG
3	2484.420	40.56	-1.99	38.57	54.00	-15.43	AVG

## Band Edges

IEEE 802.11b Mode / CH High

Detector mode: Peak

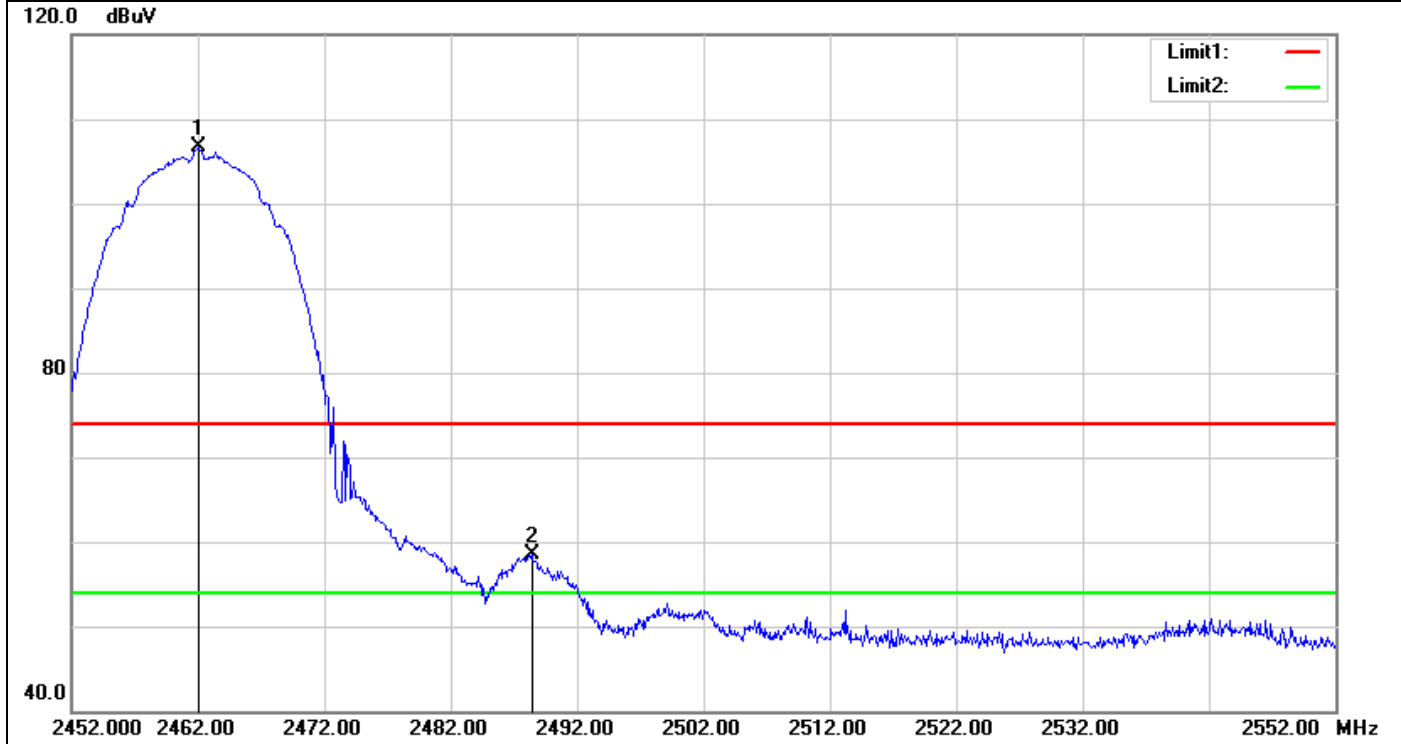

No.	Frequency (MHz)	Reading (dBuV)	Correct Factor(dB)	Result (dBuV)	Limit (dBuV)	Margin (dB)	Remark
1	2462.000	108.77	-2.10	106.67	74.00	32.67	peak
2	2488.400	60.36	-1.95	58.41	74.00	-15.59	peak

**Detector mode: Average**

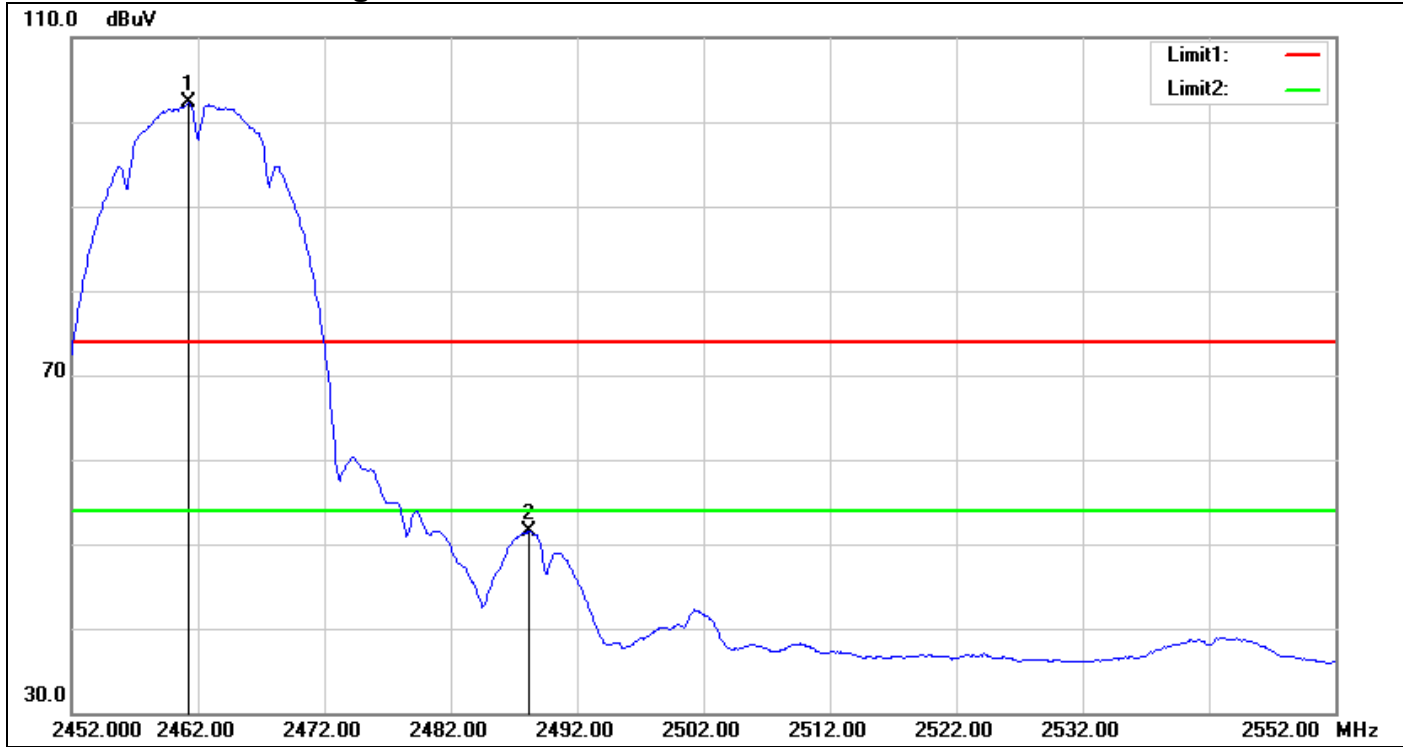

No.	Frequency (MHz)	Reading (dBuV)	Correct Factor(dB)	Result (dBuV)	Limit (dBuV)	Margin (dB)	Remark
1	2461.200	104.32	-2.10	102.22	54.00	48.22	AVG
2	2488.200	53.37	-1.95	51.42	54.00	-2.58	AVG

## Band Edges

IEEE 802.11g Mode / CH Low

Detector mode: Peak

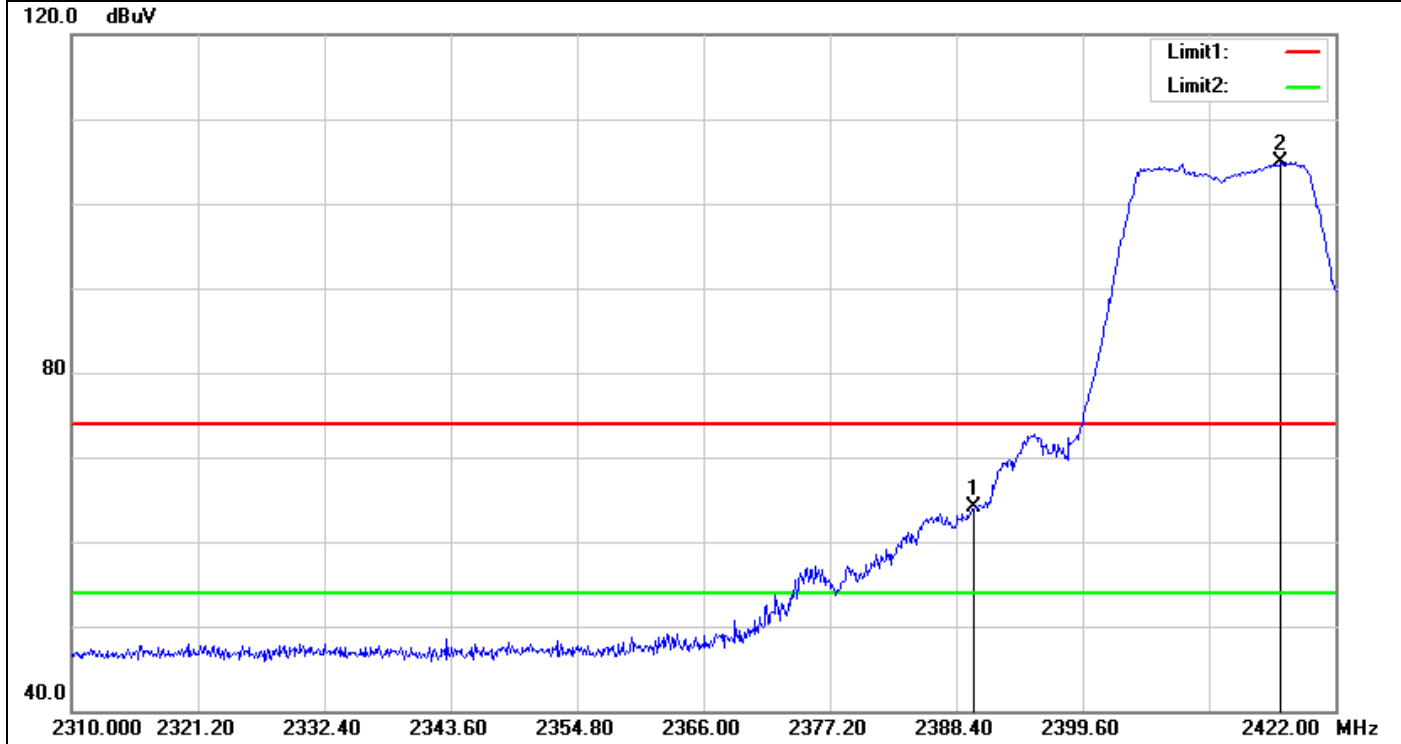

No.	Frequency (MHz)	Reading (dBuV)	Correct Factor(dB)	Result (dBuV)	Limit (dBuV)	Margin (dB)	Remark
1	2390.000	66.52	-2.49	64.03	74.00	-9.97	peak
2	2417.184	107.25	-2.38	104.87	74.00	30.87	peak

**Detector mode: Average**

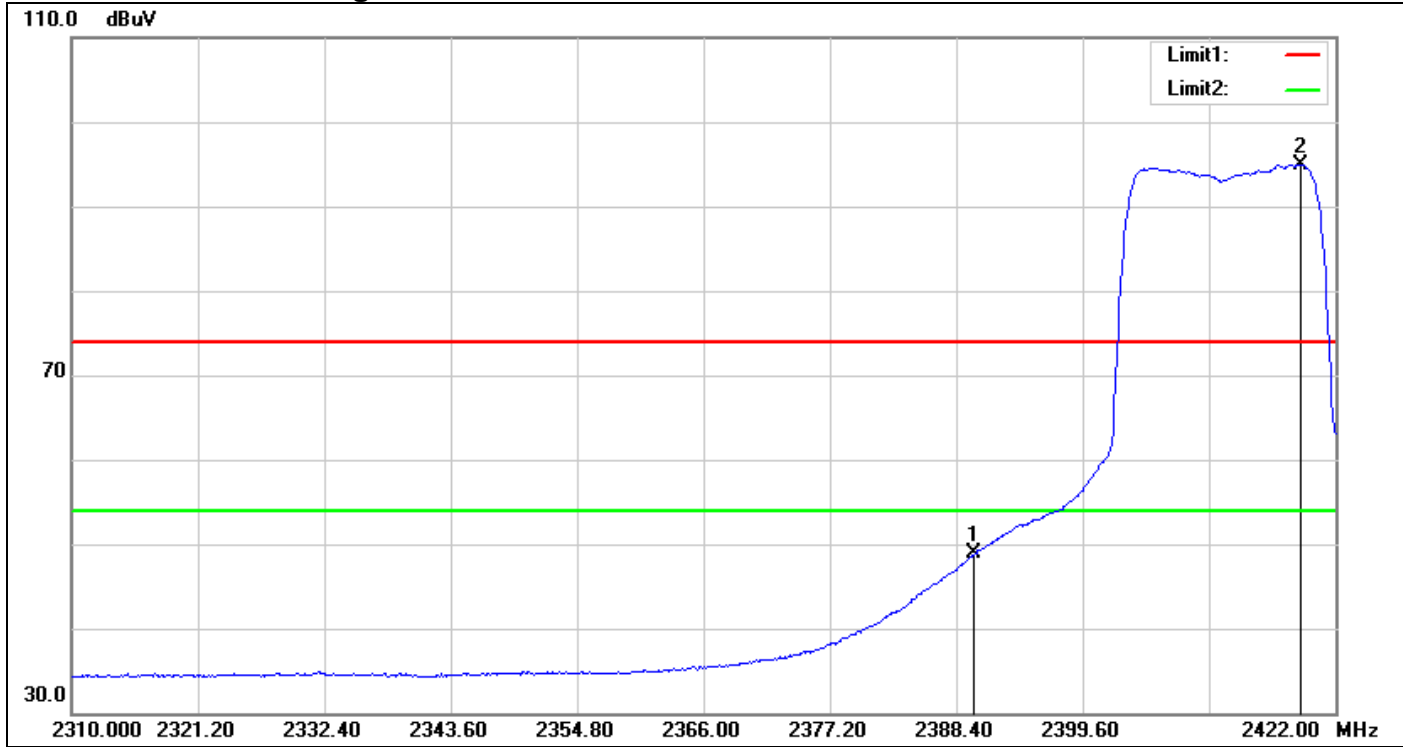

No.	Frequency (MHz)	Reading (dBuV)	Correct Factor(dB)	Result (dBuV)	Limit (dBuV)	Margin (dB)	Remark
1	2390.000	51.47	-2.49	48.98	54.00	-5.02	AVG
2	2418.864	97.35	-2.37	94.98	54.00	40.98	AVG

## Band Edges

IEEE 802.11g Mode / CH Mid

Detector mode: Peak

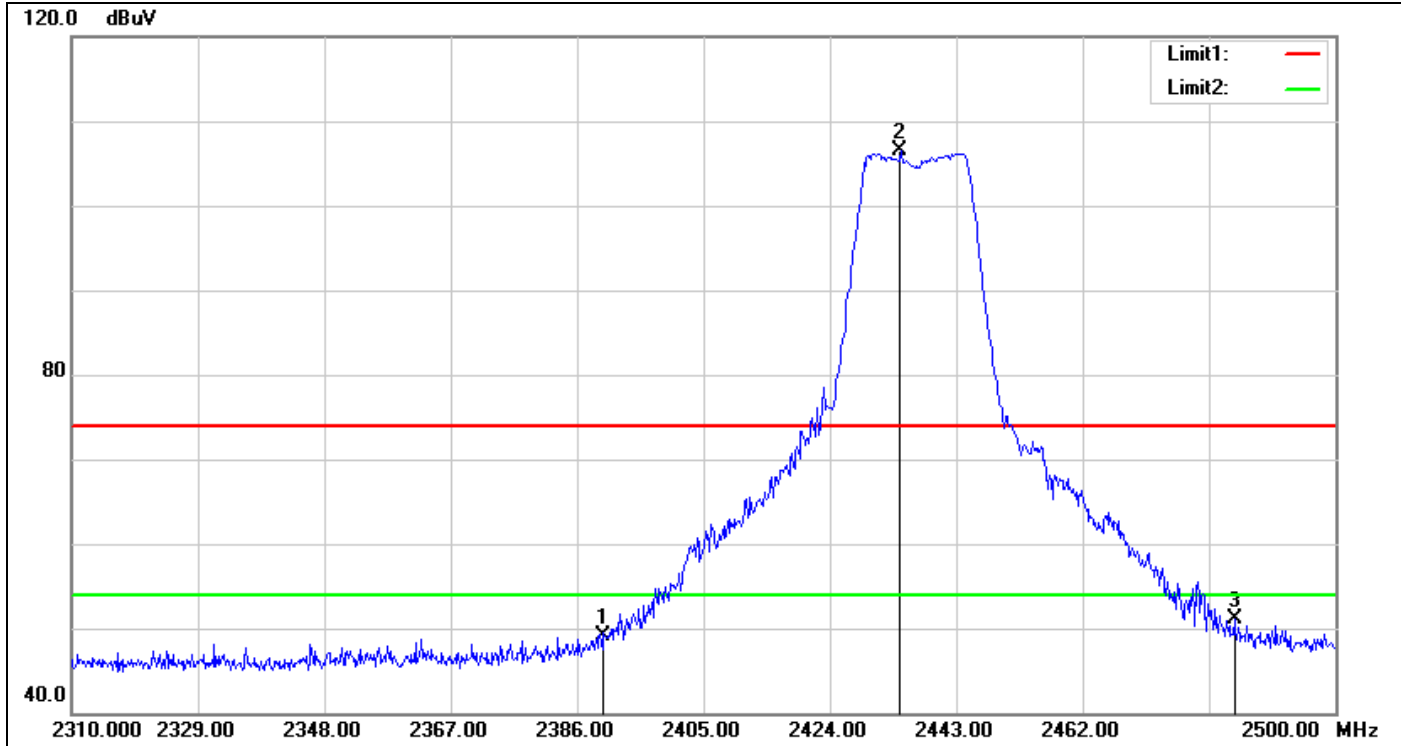

No.	Frequency (MHz)	Reading (dBuV)	Correct Factor(dB)	Result (dBuV)	Limit (dBuV)	Margin (dB)	Remark
1	2390.000	51.52	-2.49	49.03	74.00	-24.97	peak
2	2434.640	108.66	-2.25	106.41	74.00	32.41	peak
3	2484.800	53.06	-1.98	51.08	74.00	-22.92	peak



**Detector mode: Average**

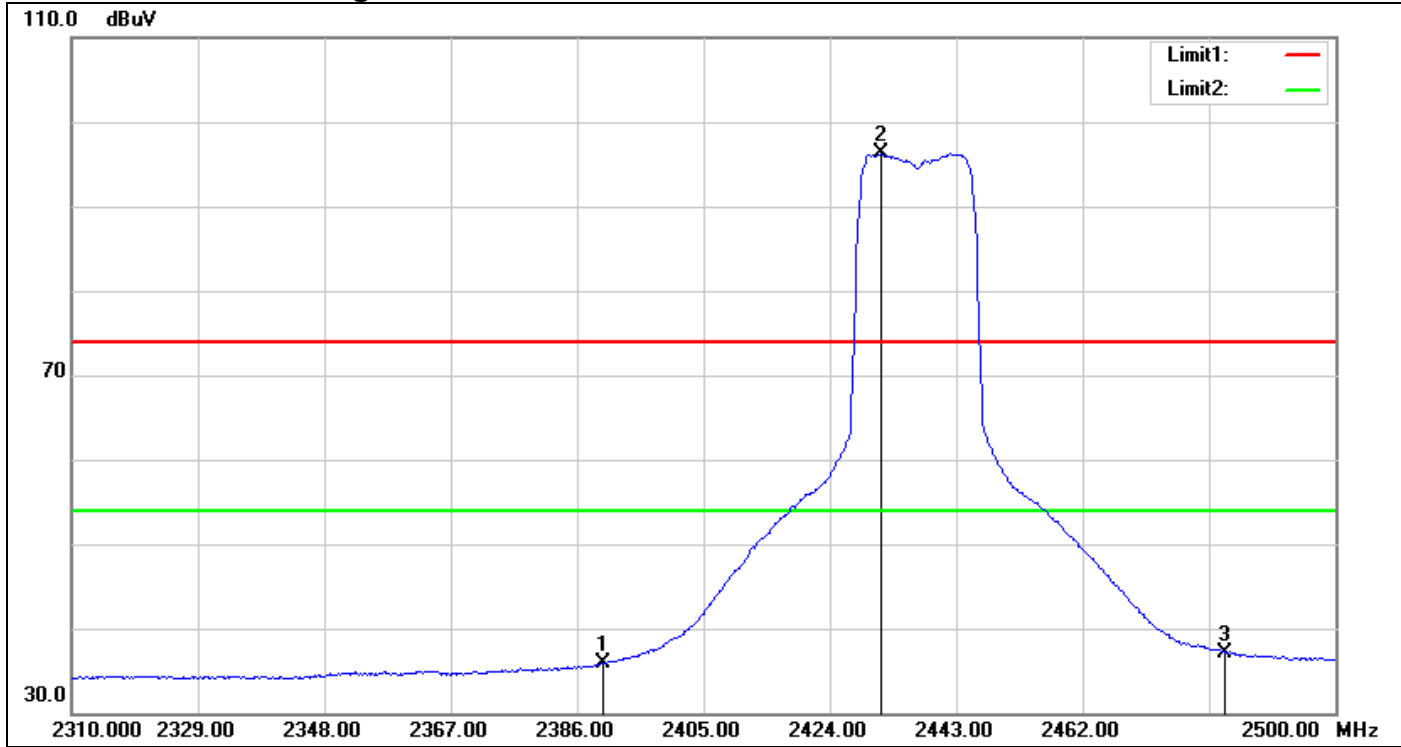

No.	Frequency (MHz)	Reading (dBuV)	Correct Factor(dB)	Result (dBuV)	Limit (dBuV)	Margin (dB)	Remark
1	2390.000	38.36	-2.49	35.87	54.00	-18.13	AVG
2	2431.790	98.57	-2.27	96.30	54.00	42.30	AVG
3	2483.500	39.17	-1.99	37.18	54.00	-16.82	AVG

## Band Edges

IEEE 802.11g Mode / CH High

Detector mode: Peak

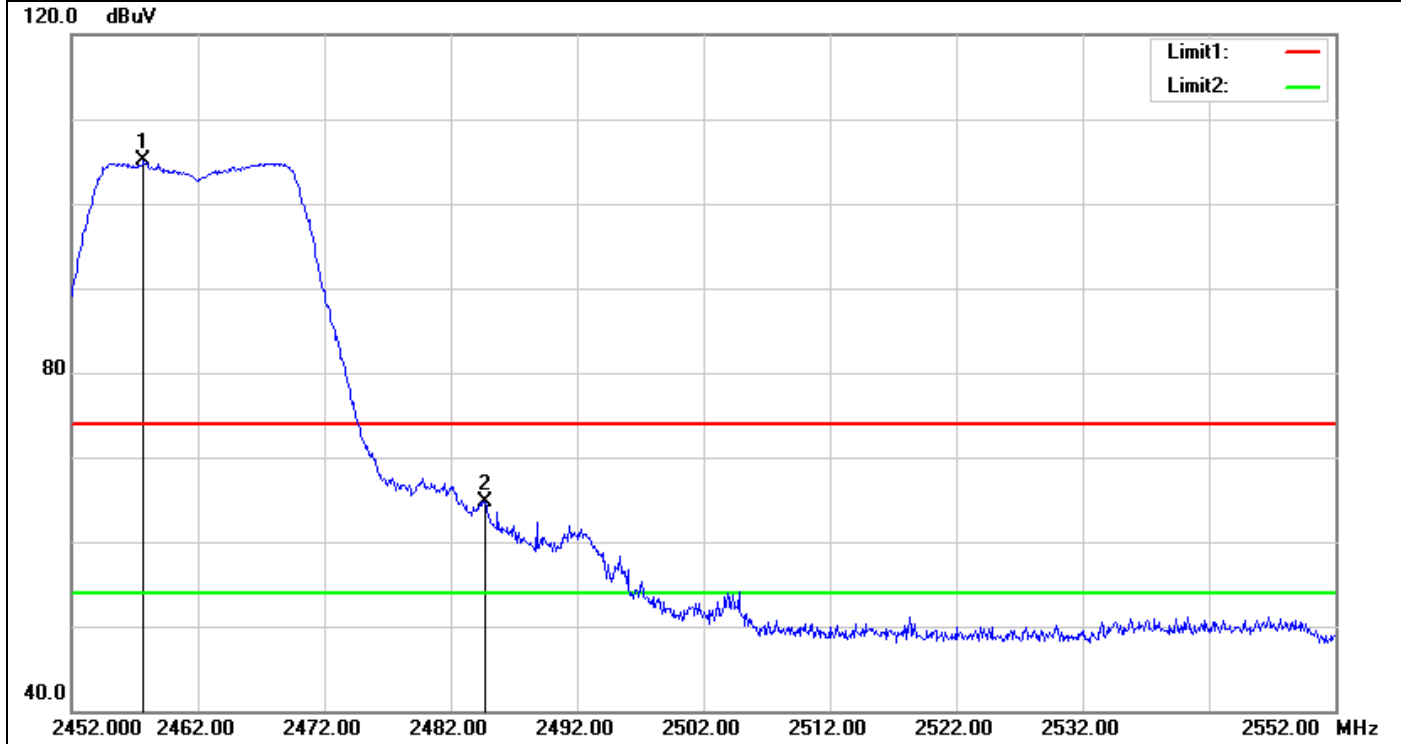

No.	Frequency (MHz)	Reading (dBuV)	Correct Factor(dB)	Result (dBuV)	Limit (dBuV)	Margin (dB)	Remark
1	2457.700	107.20	-2.11	105.09	74.00	31.09	peak
2	2484.700	66.78	-1.98	64.80	74.00	-9.20	peak

**Detector mode: Average**

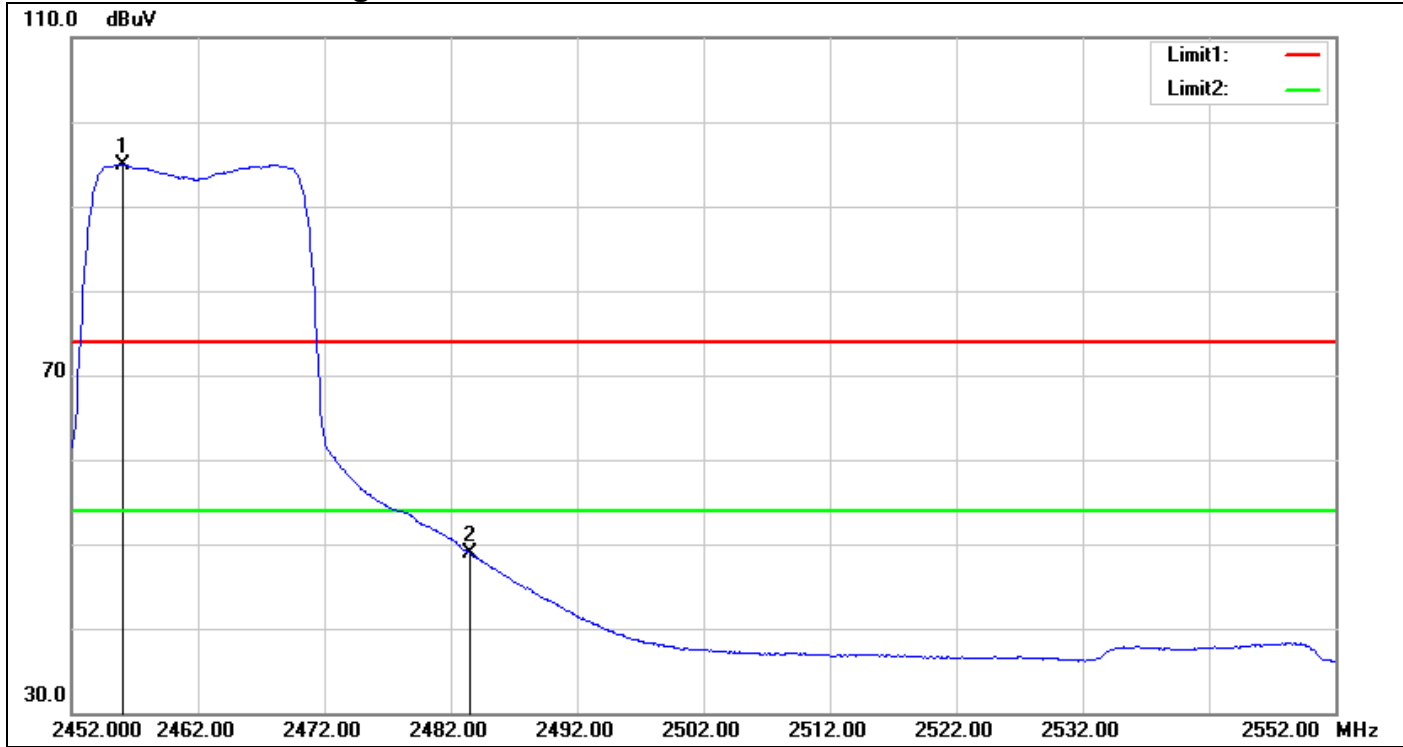

No.	Frequency (MHz)	Reading (dBuV)	Correct Factor(dB)	Result (dBuV)	Limit (dBuV)	Margin (dB)	Remark
1	2456.100	97.11	-2.12	94.99	54.00	40.99	AVG
2	2483.500	50.91	-1.99	48.92	54.00	-5.08	AVG

## Band Edges

IEEE 802.11n HT 20 MHz Mode / CH Low

Detector mode: Peak

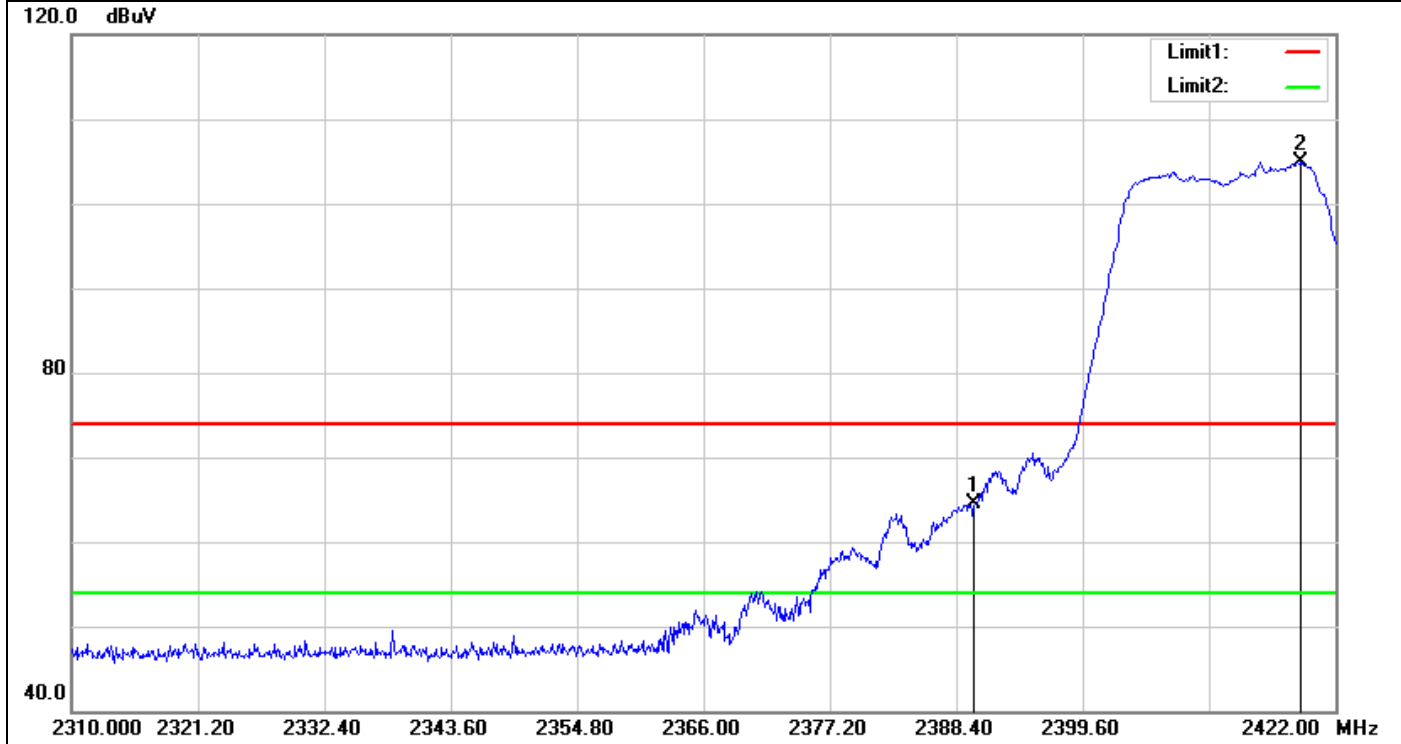

No.	Frequency (MHz)	Reading (dBuV)	Correct Factor(dB)	Result (dBuV)	Limit (dBuV)	Margin (dB)	Remark
1	2390.000	66.93	-2.49	64.44	74.00	-9.56	peak
2	2418.864	107.26	-2.37	104.89	74.00	30.89	peak

**Detector mode: Average**

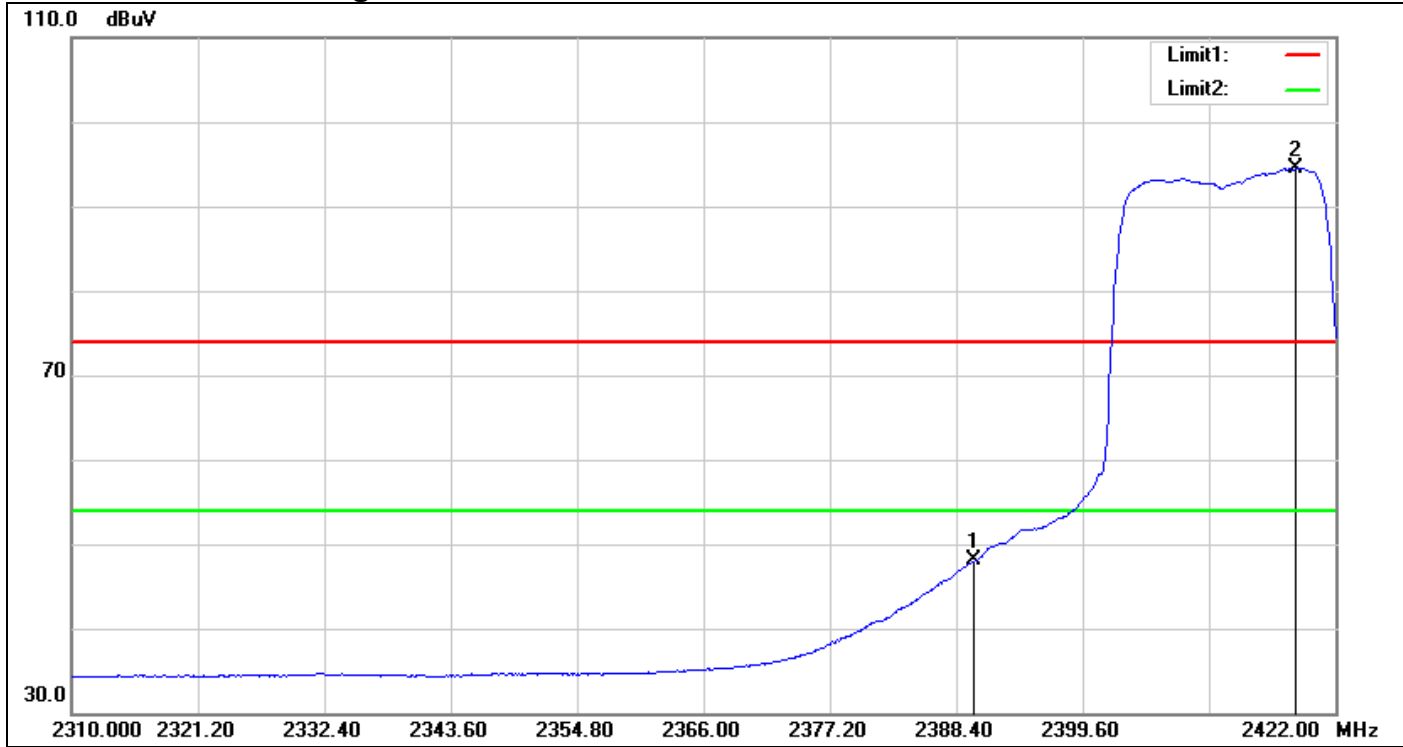

No.	Frequency (MHz)	Reading (dBuV)	Correct Factor(dB)	Result (dBuV)	Limit (dBuV)	Margin (dB)	Remark
1	2390.000	50.59	-2.49	48.10	54.00	-5.90	AVG
2	2418.528	96.91	-2.37	94.54	54.00	40.54	AVG

## Band Edges

IEEE 802.11n HT 20 MHz Mode / CH Mid

Detector mode: Peak

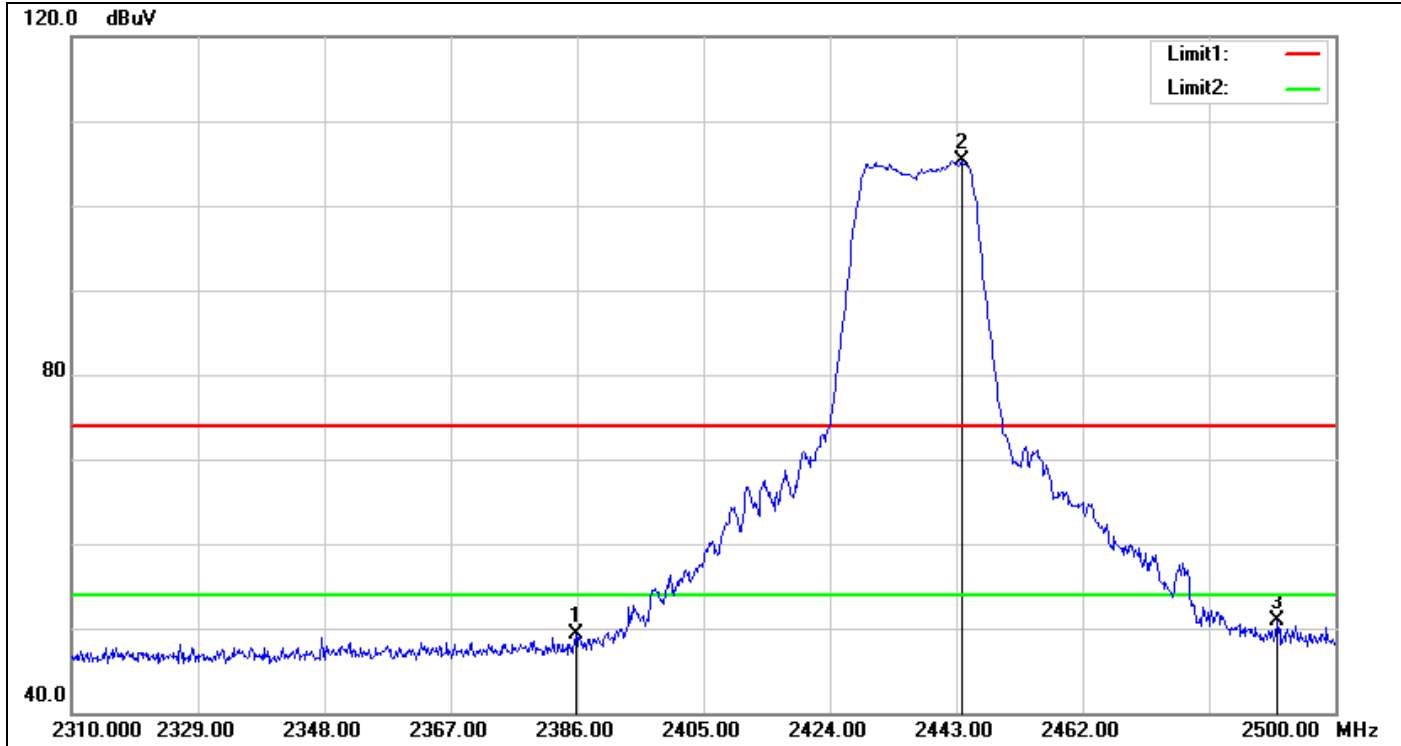

No.	Frequency (MHz)	Reading (dBuV)	Correct Factor(dB)	Result (dBuV)	Limit (dBuV)	Margin (dB)	Remark
1	2385.810	51.76	-2.53	49.23	74.00	-24.77	peak
2	2443.760	107.58	-2.19	105.39	74.00	31.39	peak
3	2491.260	52.75	-1.92	50.83	74.00	-23.17	peak

**Detector mode: Average**

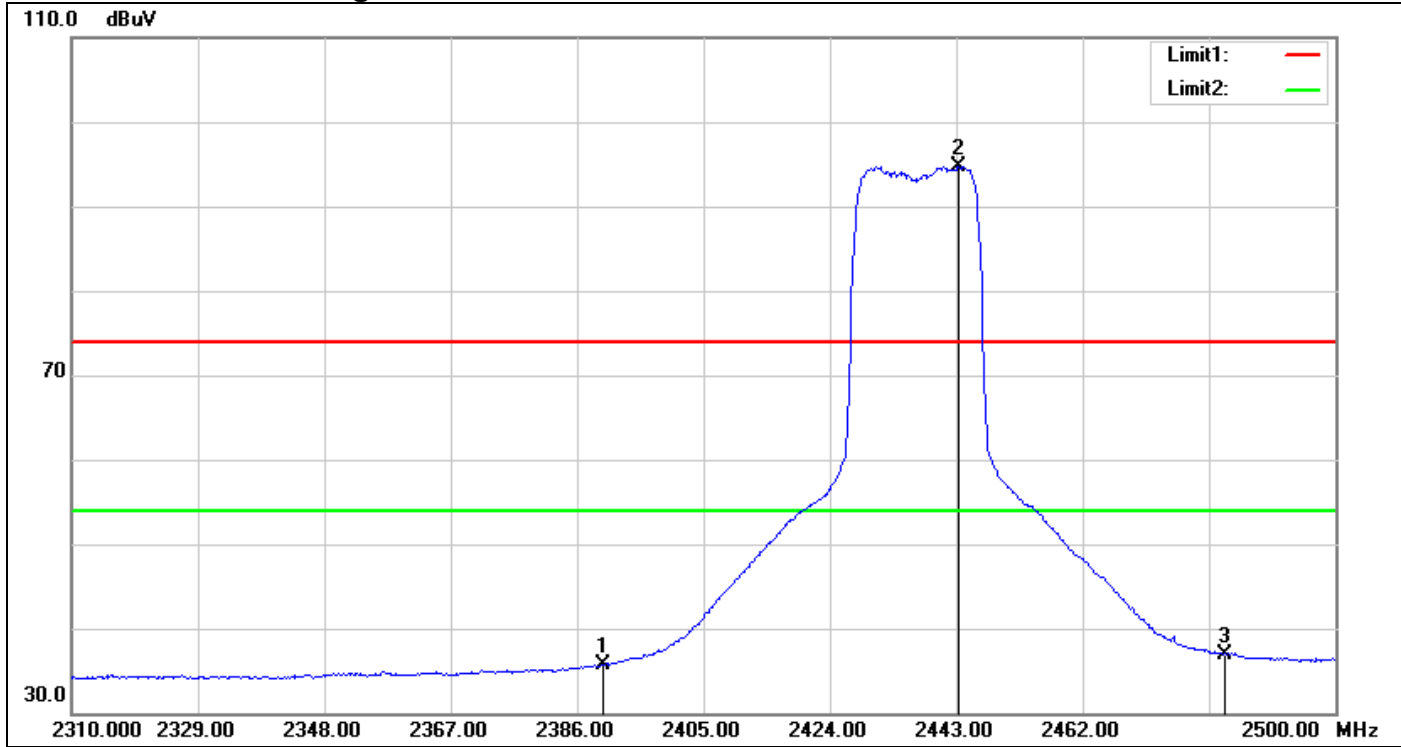

No.	Frequency (MHz)	Reading (dBuV)	Correct Factor(dB)	Result (dBuV)	Limit (dBuV)	Margin (dB)	Remark
1	2390.000	38.27	-2.49	35.78	54.00	-18.22	AVG
2	2443.380	96.93	-2.19	94.74	54.00	40.74	AVG
3	2483.500	38.95	-1.99	36.96	54.00	-17.04	AVG

## Band Edges

IEEE 802.11n HT 20 MHz Mode / CH High

Detector mode: Peak

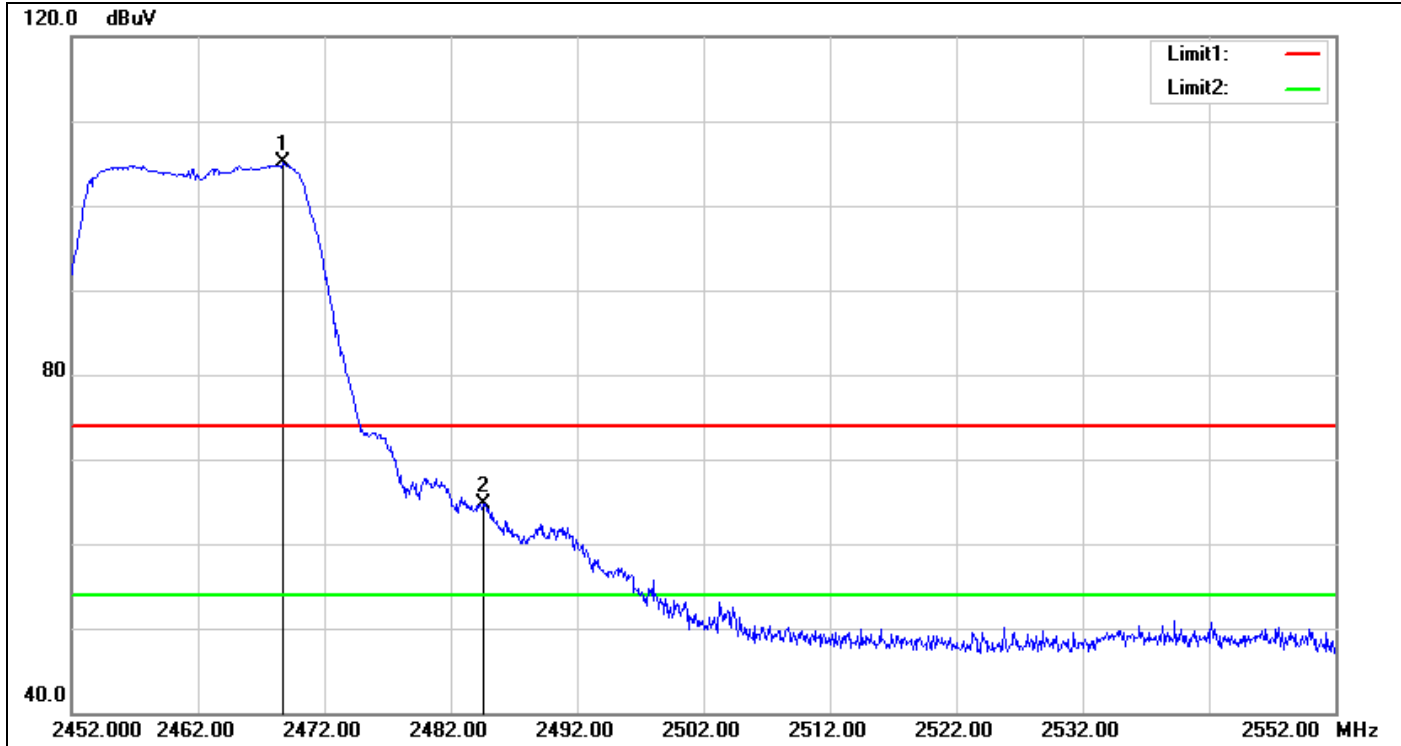

No.	Frequency (MHz)	Reading (dBuV)	Correct Factor(dB)	Result (dBuV)	Limit (dBuV)	Margin (dB)	Remark
1	2468.700	107.23	-2.07	105.16	74.00	31.16	peak
2	2484.600	66.76	-1.98	64.78	74.00	-9.22	peak



**Detector mode: Average**

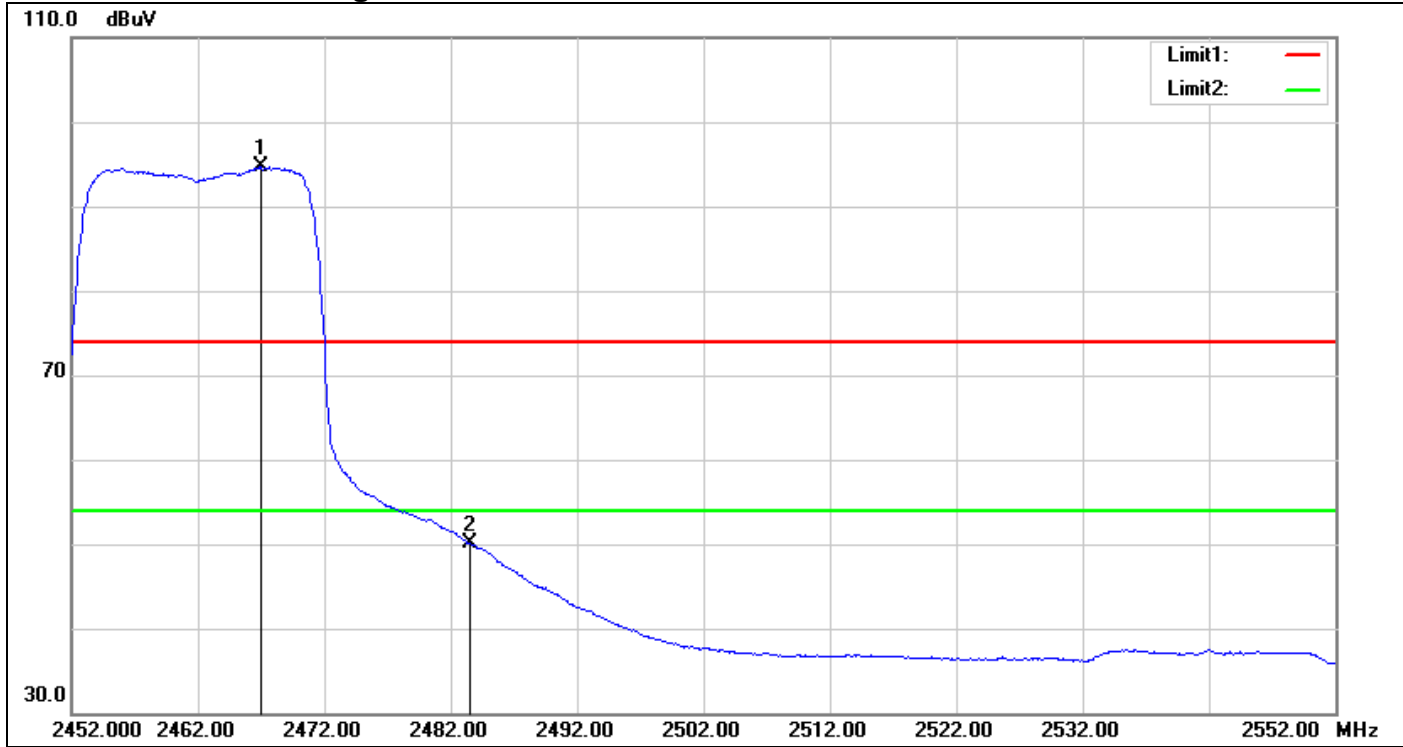

No.	Frequency (MHz)	Reading (dBuV)	Correct Factor(dB)	Result (dBuV)	Limit (dBuV)	Margin (dB)	Remark
1	2467.000	96.71	-2.08	94.63	54.00	40.63	AVG
2	2483.500	52.05	-1.99	50.06	54.00	-3.94	AVG

## Band Edges

IEEE 802.11n HT 40 MHz Mode / CH Low

Detector mode: Peak

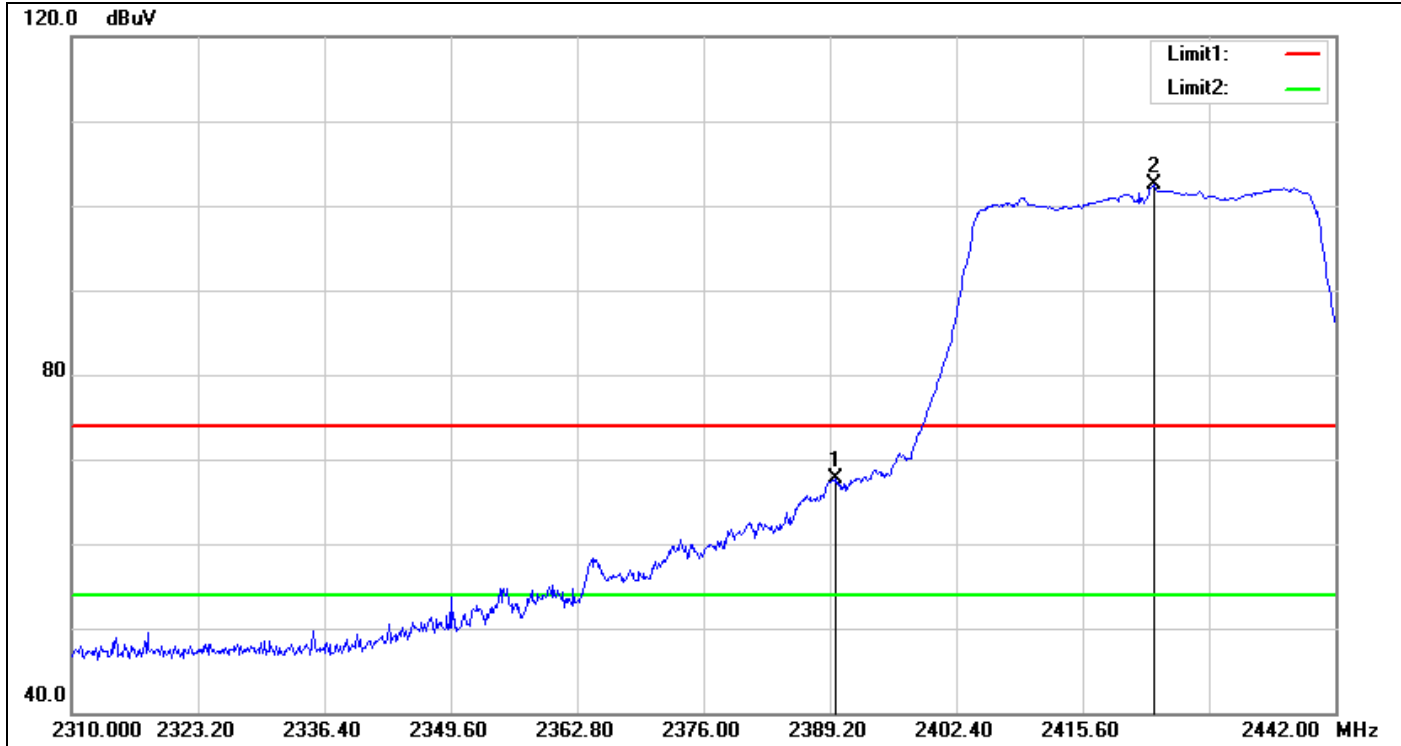

No.	Frequency (MHz)	Reading (dBuV)	Correct Factor(dB)	Result (dBuV)	Limit (dBuV)	Margin (dB)	Remark
1	2389.860	70.24	-2.49	67.75	74.00	-6.25	peak
2	2423.124	104.80	-2.33	102.47	74.00	28.47	peak

**Detector mode: Average**

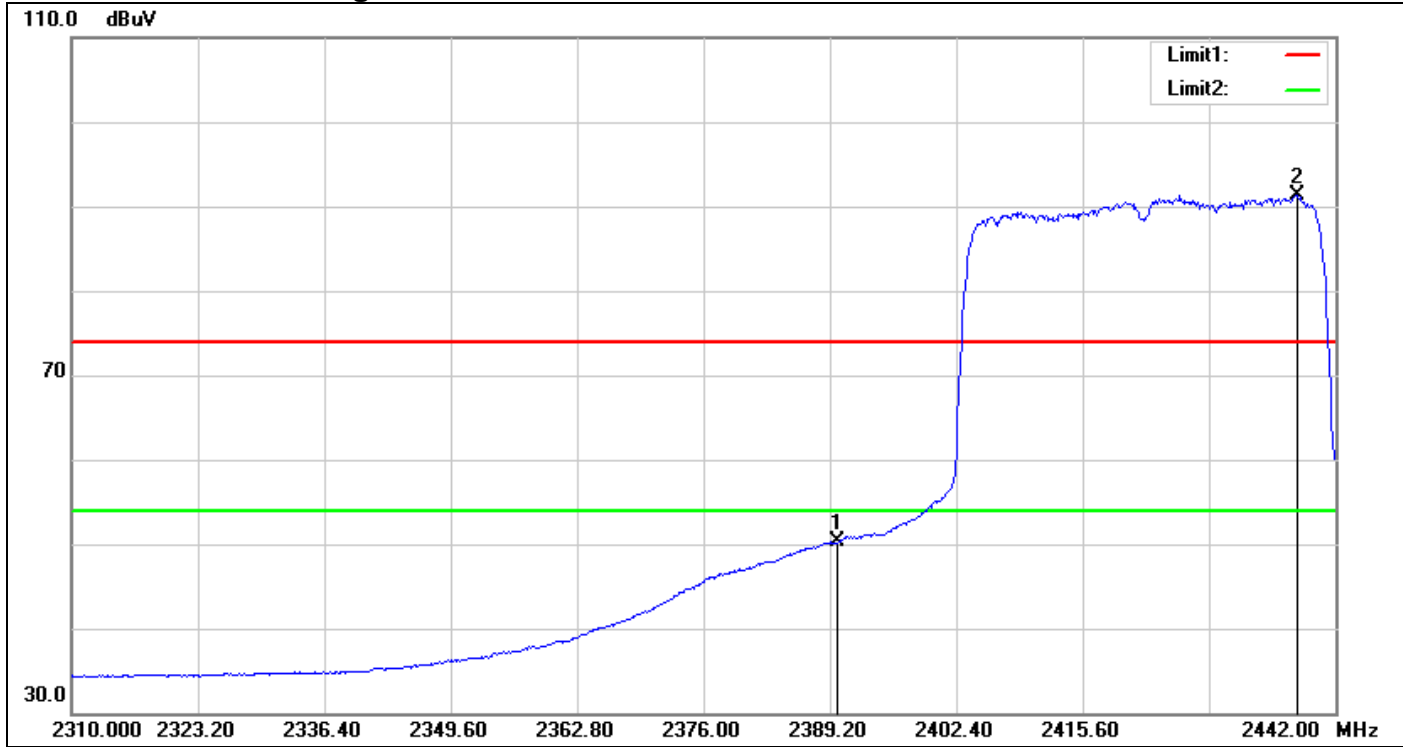

No.	Frequency (MHz)	Reading (dBuV)	Correct Factor(dB)	Result (dBuV)	Limit (dBuV)	Margin (dB)	Remark
1	2390.000	52.72	-2.49	50.23	54.00	-3.77	AVG
2	2438.040	93.56	-2.23	91.33	54.00	37.33	AVG

## Band Edges

IEEE 802.11n HT 40 MHz Mode / CH Mid

Detector mode: Peak

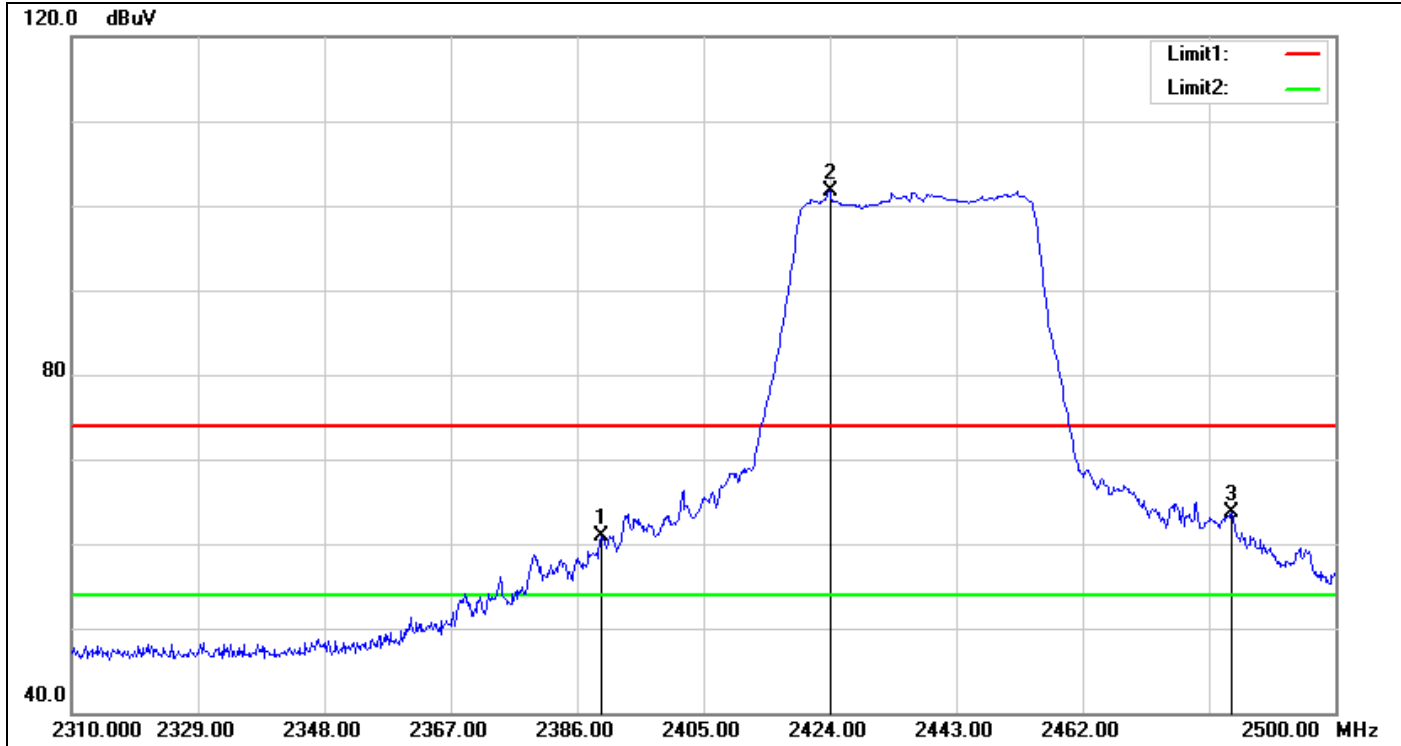

No.	Frequency (MHz)	Reading (dBuV)	Correct Factor(dB)	Result (dBuV)	Limit (dBuV)	Margin (dB)	Remark
1	2389.610	63.32	-2.49	60.83	74.00	-13.17	peak
2	2424.000	103.99	-2.33	101.66	74.00	27.66	peak
3	2484.420	65.78	-1.99	63.79	74.00	-10.21	peak

**Detector mode: Average**

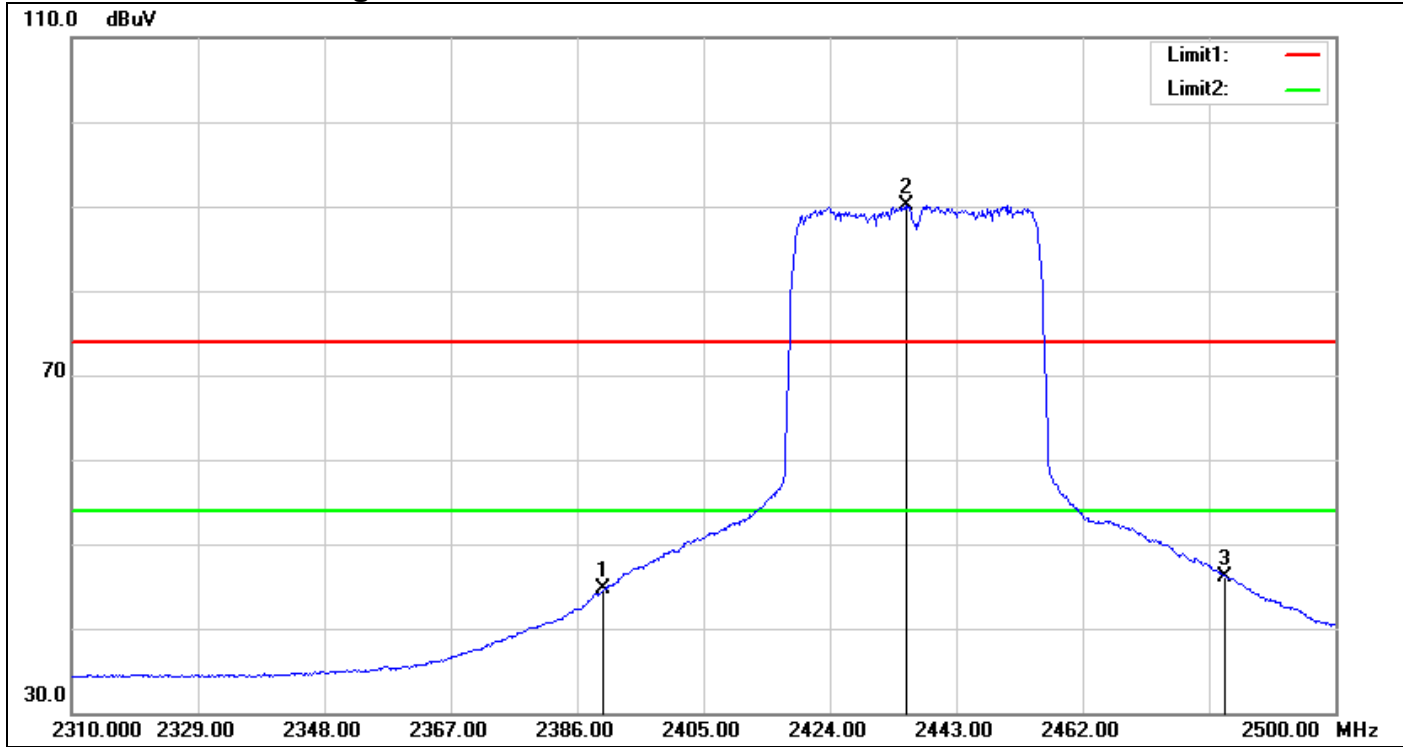

No.	Frequency (MHz)	Reading (dBuV)	Correct Factor(dB)	Result (dBuV)	Limit (dBuV)	Margin (dB)	Remark
1	2390.000	47.21	-2.49	44.72	54.00	-9.28	AVG
2	2435.400	92.40	-2.25	90.15	54.00	36.15	AVG
3	2483.500	48.01	-1.99	46.02	54.00	-7.98	AVG

## Band Edges

IEEE 802.11n HT 40 MHz Mode / CH High

Detector mode: Peak

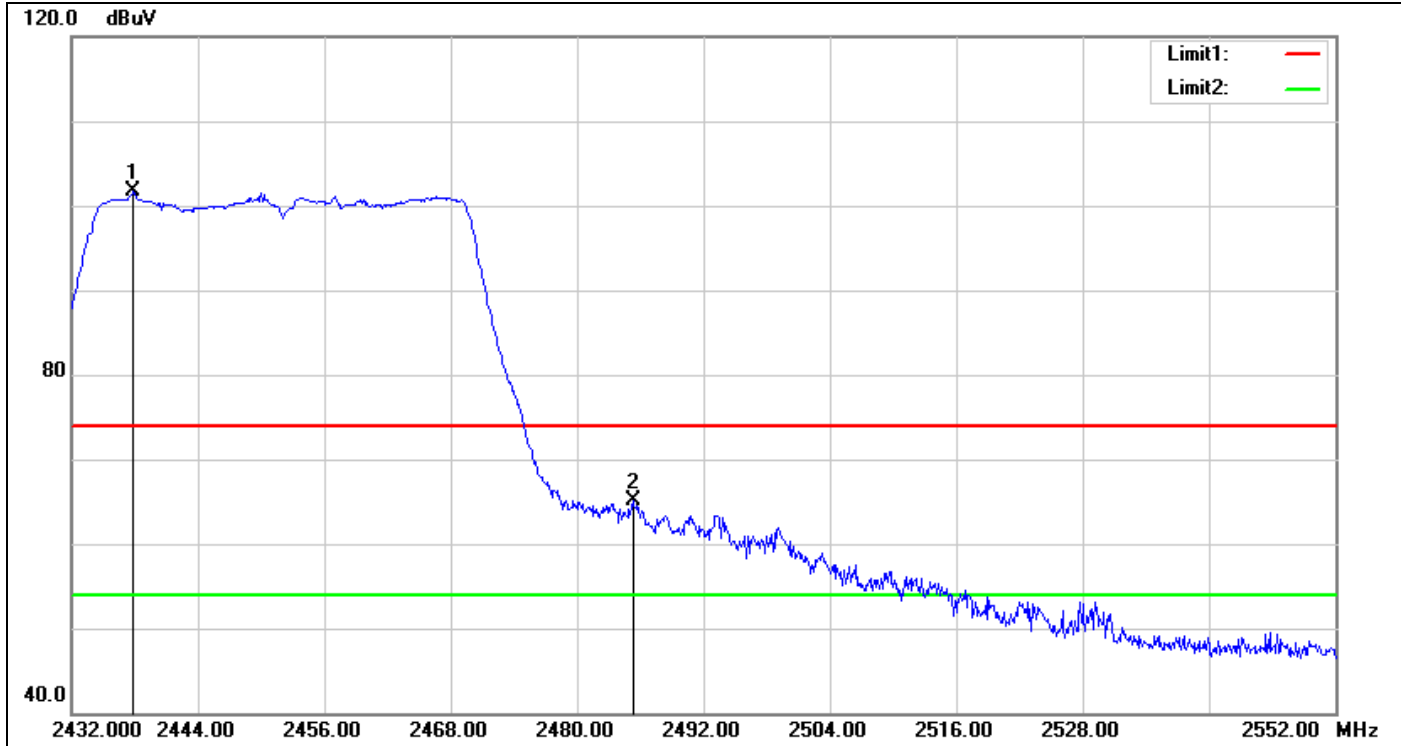

No.	Frequency (MHz)	Reading (dBuV)	Correct Factor(dB)	Result (dBuV)	Limit (dBuV)	Margin (dB)	Remark
1	2437.880	103.87	-2.23	101.64	74.00	27.64	peak
2	2485.280	67.09	-1.98	65.11	74.00	-8.89	peak

**Detector mode: Average**

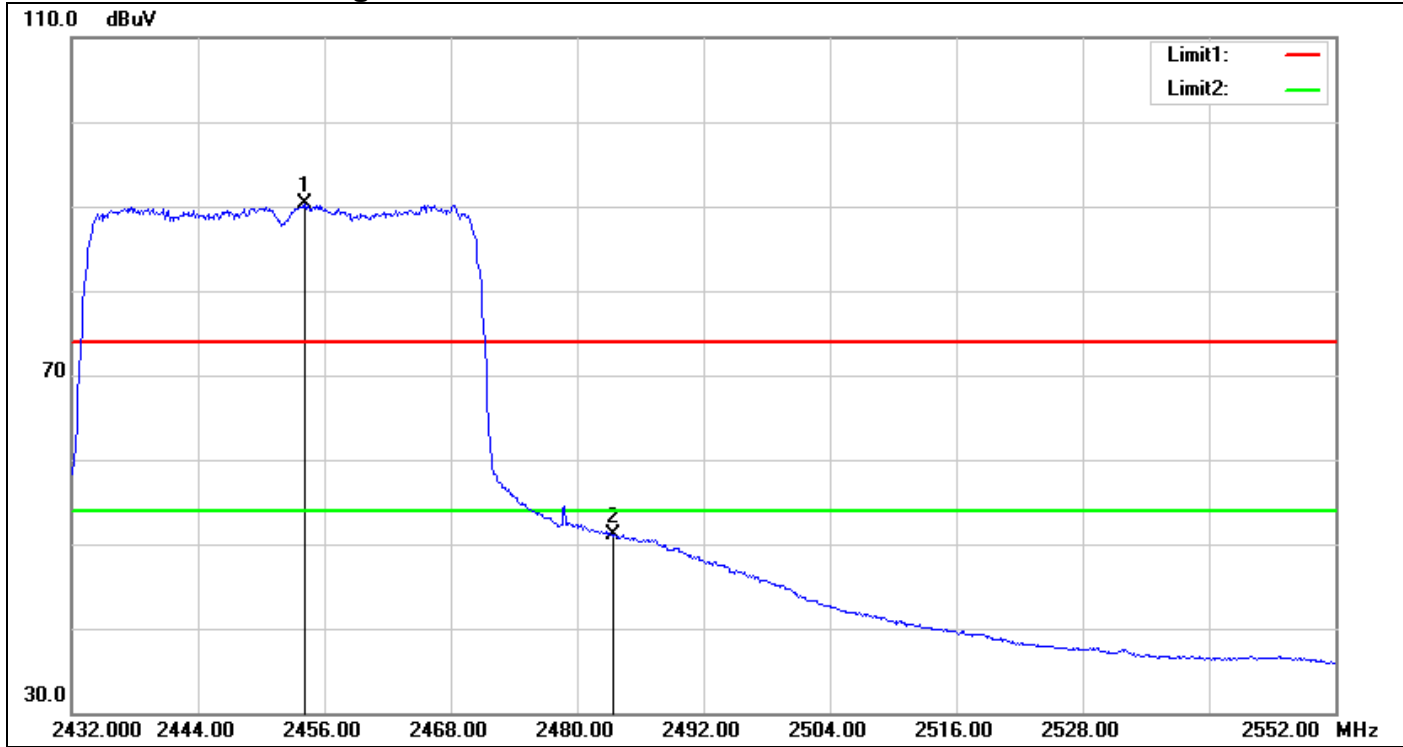

No.	Frequency (MHz)	Reading (dBuV)	Correct Factor(dB)	Result (dBuV)	Limit (dBuV)	Margin (dB)	Remark
1	2454.080	92.36	-2.13	90.23	54.00	36.23	AVG
2	2483.500	53.02	-1.99	51.03	54.00	-2.97	AVG

**Test Plot**

**Un-restricted Band Emissions (IEEE 802.11b mode / CH Low)**

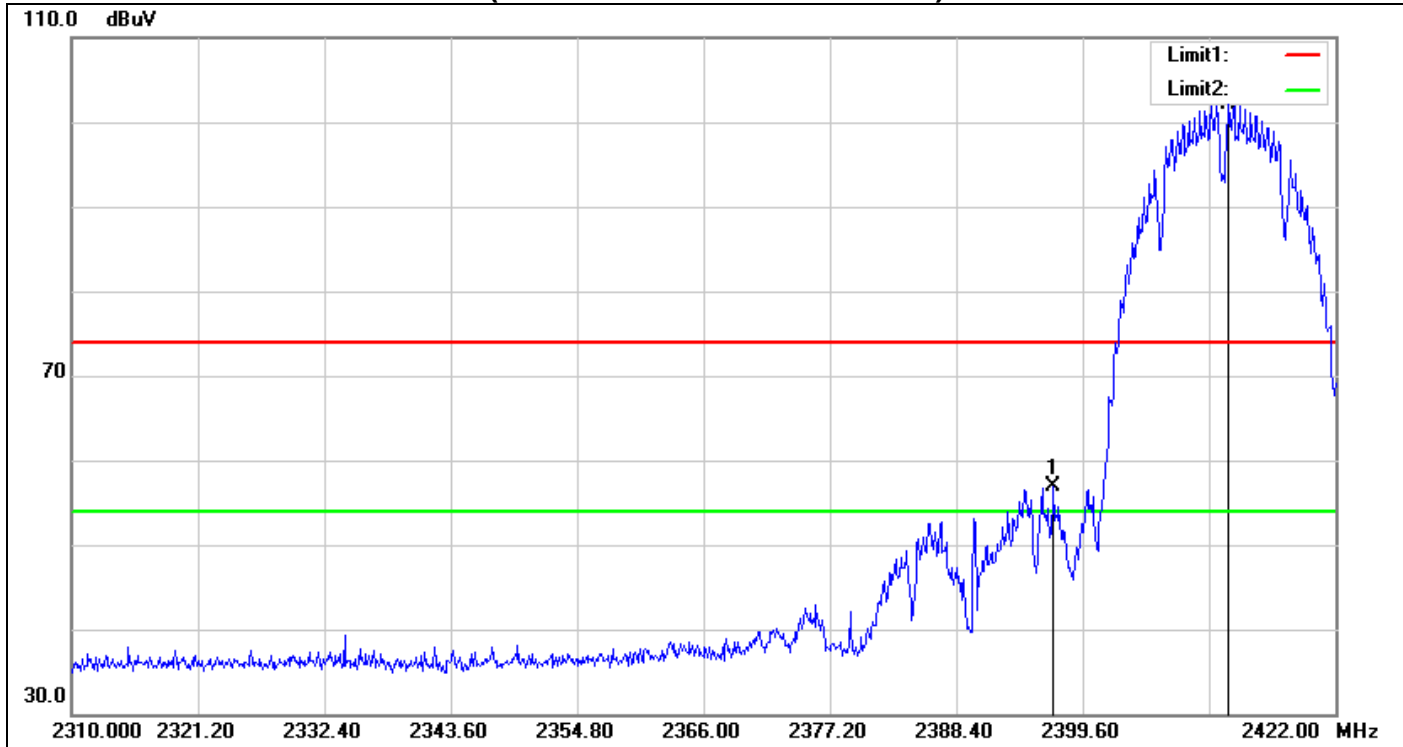

No.	Frequency (MHz)	Reading (dBuV)	Correct Factor(dB)	Result (dBuV)	Limit (dBuV)	Margin (dB)	Remark
1	2397.024	59.42	-2.43	56.99	74.00	-17.01	peak
2	2412.480	104.45	-2.41	102.04	74.00	28.04	peak

**Note: Spurious emission levels that exceed the level of 20 dB below the applicable limit.**



**Un-restricted Band Emissions (IEEE 802.11b mode / CH High)**

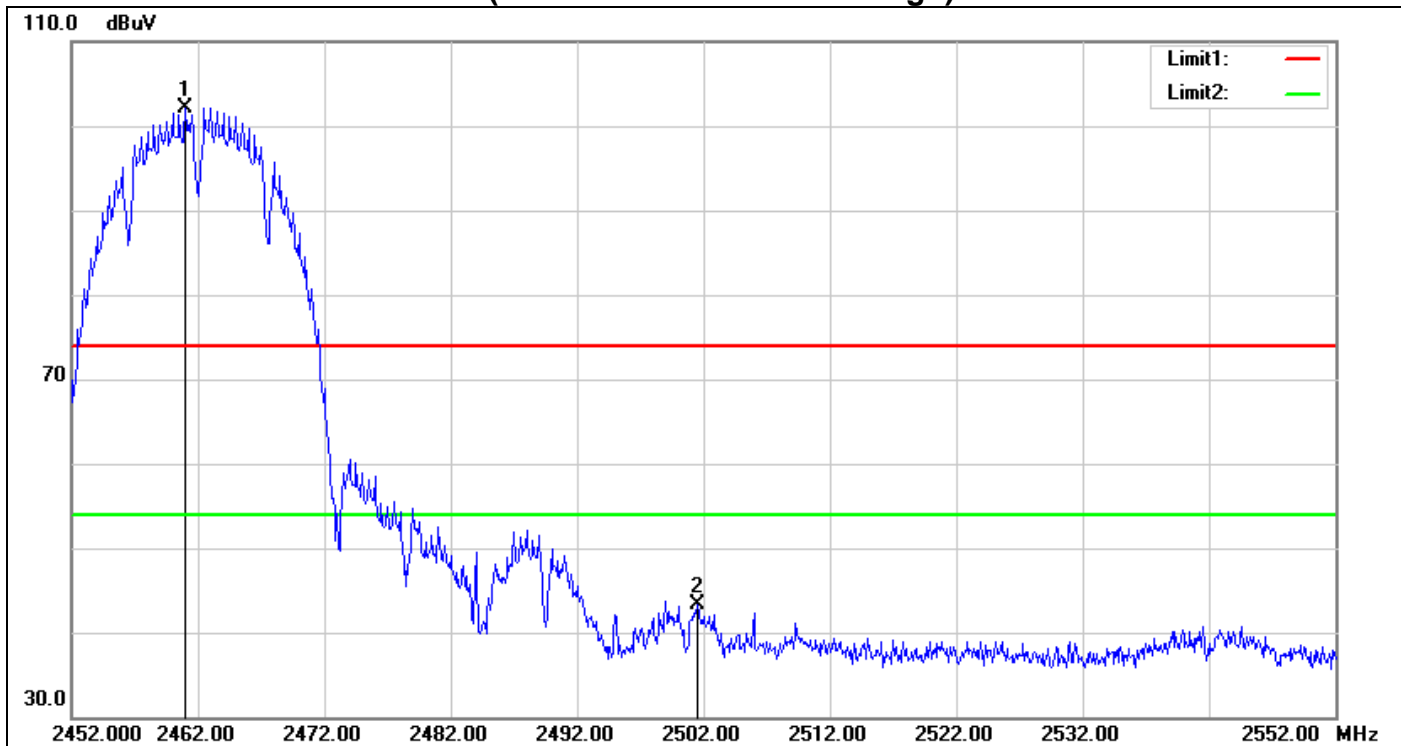

No.	Frequency (MHz)	Reading (dBuV)	Correct Factor(dB)	Result (dBuV)	Limit (dBuV)	Margin (dB)	Remark
1	2461.000	104.13	-2.10	102.03	74.00	28.03	peak
2	2501.500	45.16	-1.86	43.30	74.00	-30.70	peak

**Note: Spurious emission levels that exceed the level of 20 dB below the applicable limit.**

**Un-restricted Band Emissions (IEEE 802.11g mode / CH Low)**

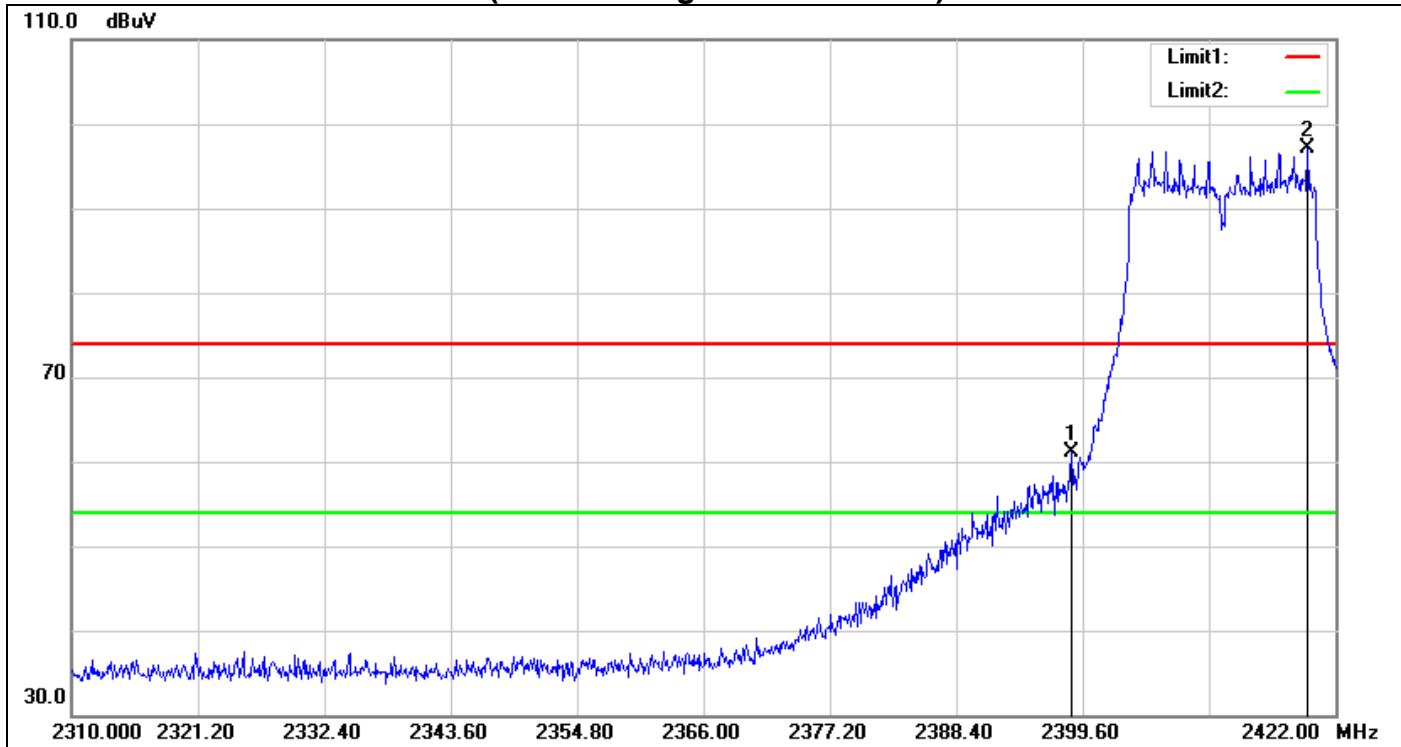

No.	Frequency (MHz)	Reading (dBuV)	Correct Factor(dB)	Result (dBuV)	Limit (dBuV)	Margin (dB)	Remark
1	2398.592	63.52	-2.42	61.10	74.00	-12.90	peak
2	2419.536	99.47	-2.36	97.11	74.00	23.11	peak

**Note: Spurious emission levels that exceed the level of 20 dB below the applicable limit.**

**Un-restricted Band Emissions (IEEE 802.11g mode / CH High)**

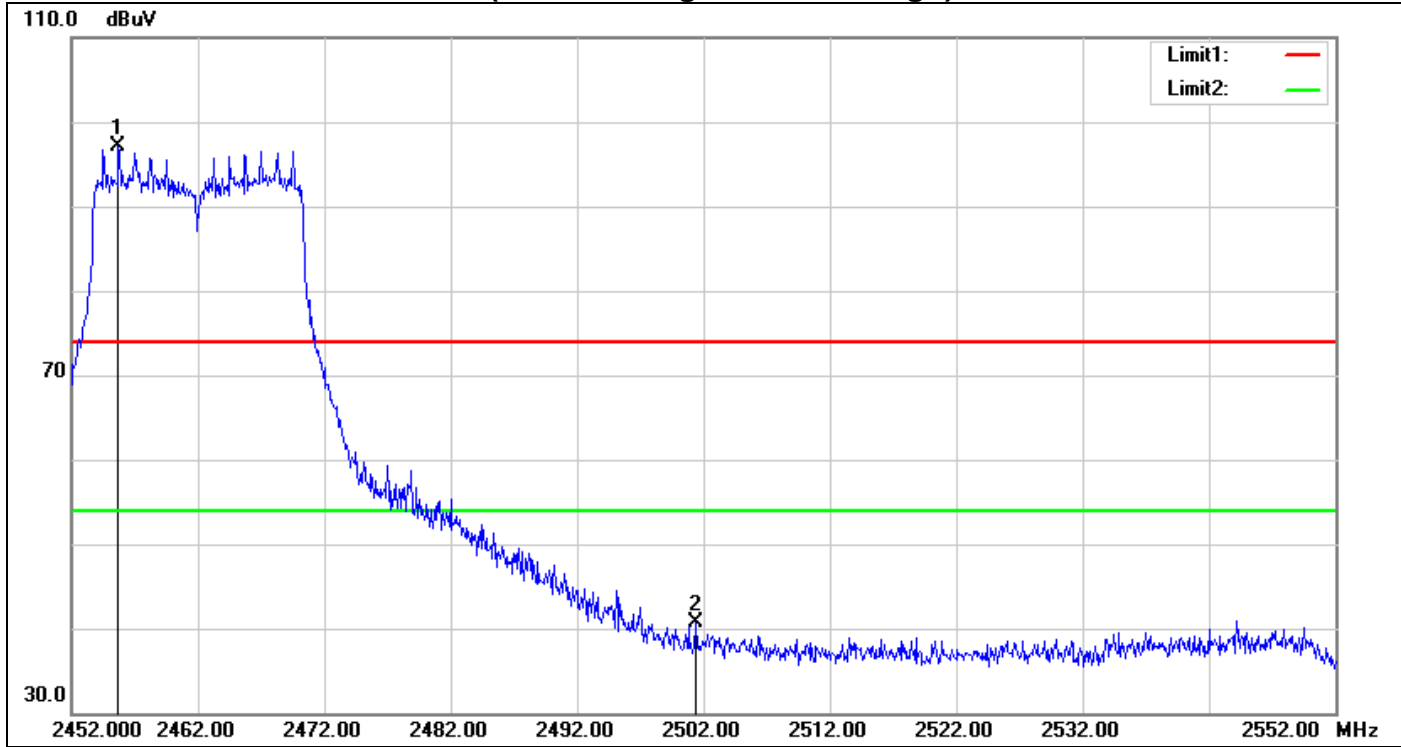

No.	Frequency (MHz)	Reading (dBuV)	Correct Factor (dB)	Result (dBuV)	Limit (dBuV)	Margin (dB)	Remark
1	2455.700	99.15	-2.12	97.03	74.00	23.03	peak
2	2501.400	42.50	-1.86	40.64	74.00	-33.36	peak

**Note: Spurious emission levels that exceed the level of 20 dB below the applicable limit.**

**Un-restricted Band Emissions (IEEE 802.11n HT 20 MHz mode / CH Low)**

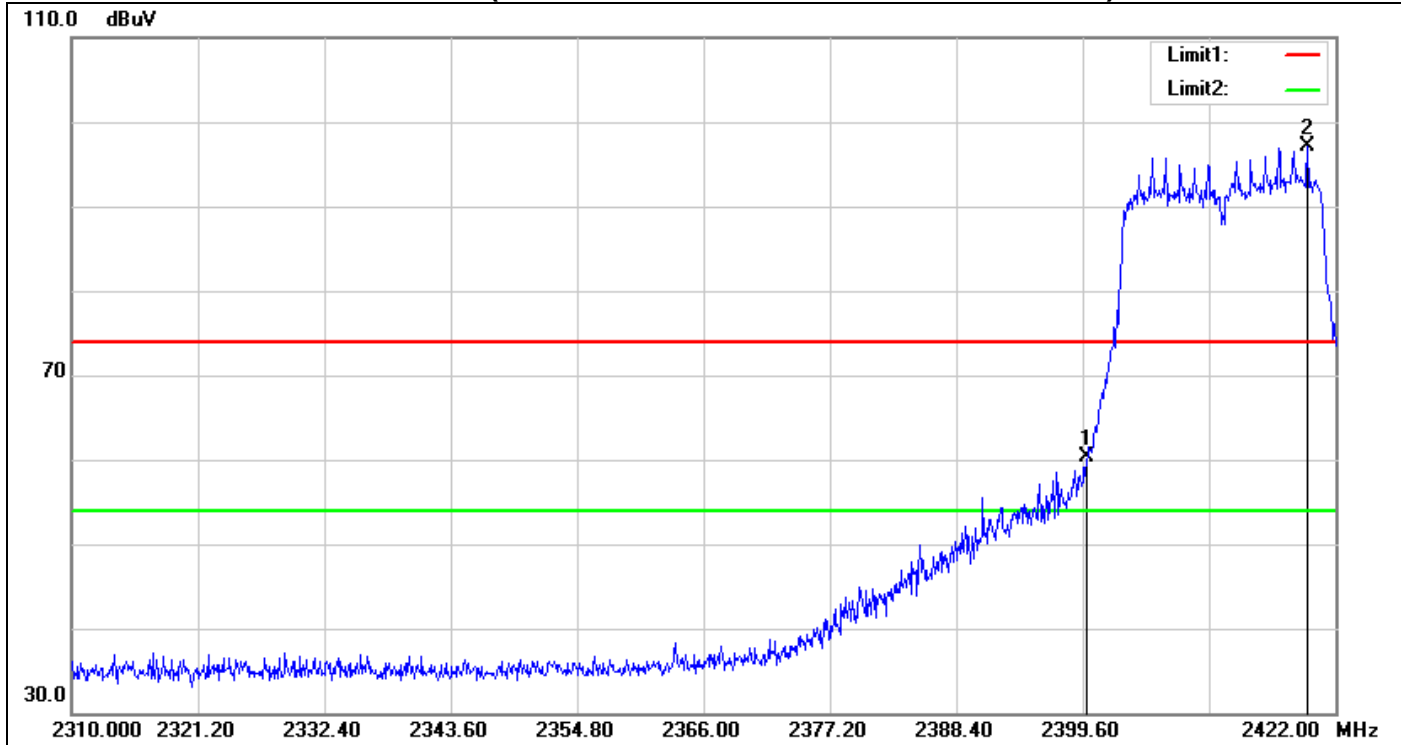

No.	Frequency (MHz)	Reading (dBuV)	Correct Factor (dB)	Result (dBuV)	Limit (dBuV)	Margin (dB)	Remark
1	2400.000	62.63	-2.41	60.22	74.00	-13.78	peak
2	2419.536	99.37	-2.36	97.01	74.00	23.01	peak

**Note: Spurious emission levels that exceed the level of 20 dB below the applicable limit.**

**Un-restricted Band Emissions (IEEE 802.11n HT 20 MHz mode / CH High)**

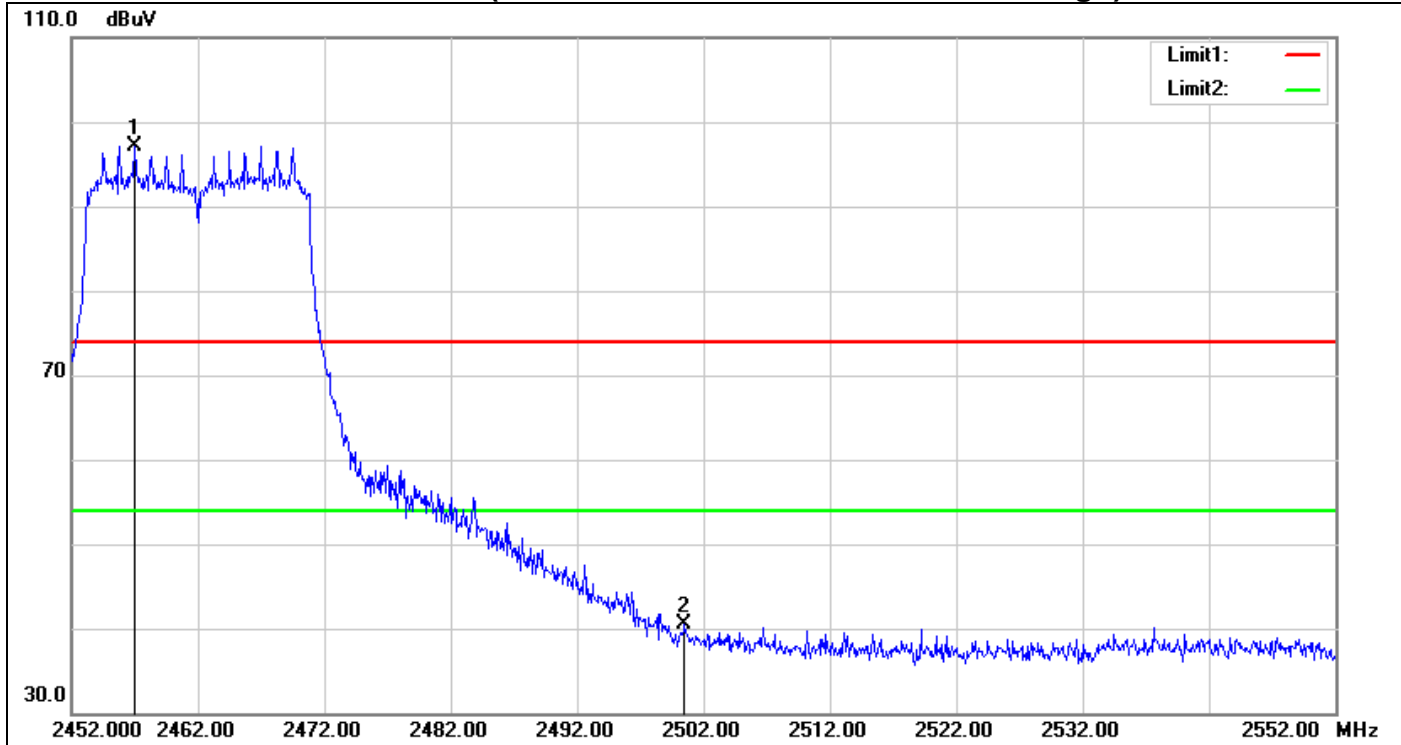

No.	Frequency (MHz)	Reading (dBuV)	Correct Factor(dB)	Result (dBuV)	Limit (dBuV)	Margin (dB)	Remark
1	2457.000	99.18	-2.11	97.07	74.00	23.07	peak
2	2500.500	42.42	-1.86	40.56	74.00	-33.44	peak

**Note: Spurious emission levels that exceed the level of 20 dB below the applicable limit.**

**Un-restricted Band Emissions (IEEE 802.11n HT 40 MHz mode / CH Low)**

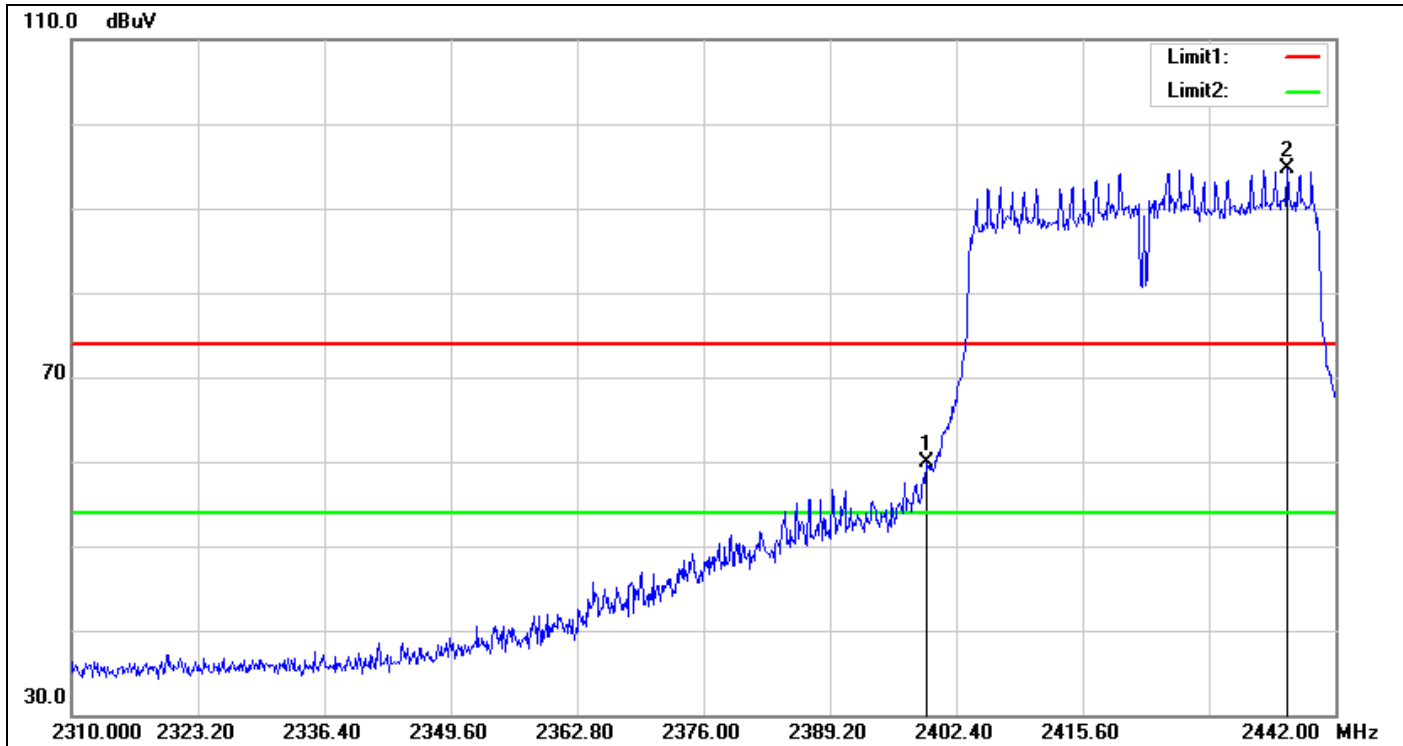

No.	Frequency (MHz)	Reading (dBuV)	Correct Factor(dB)	Result (dBuV)	Limit (dBuV)	Margin (dB)	Remark
1	2399.364	62.28	-2.42	59.86	74.00	-14.14	peak
2	2436.984	97.02	-2.23	94.79	74.00	20.79	peak

**Note: Spurious emission levels that exceed the level of 20 dB below the applicable limit.**

**Un-restricted Band Emissions (IEEE 802.11n HT 40 MHz mode / CH High)**

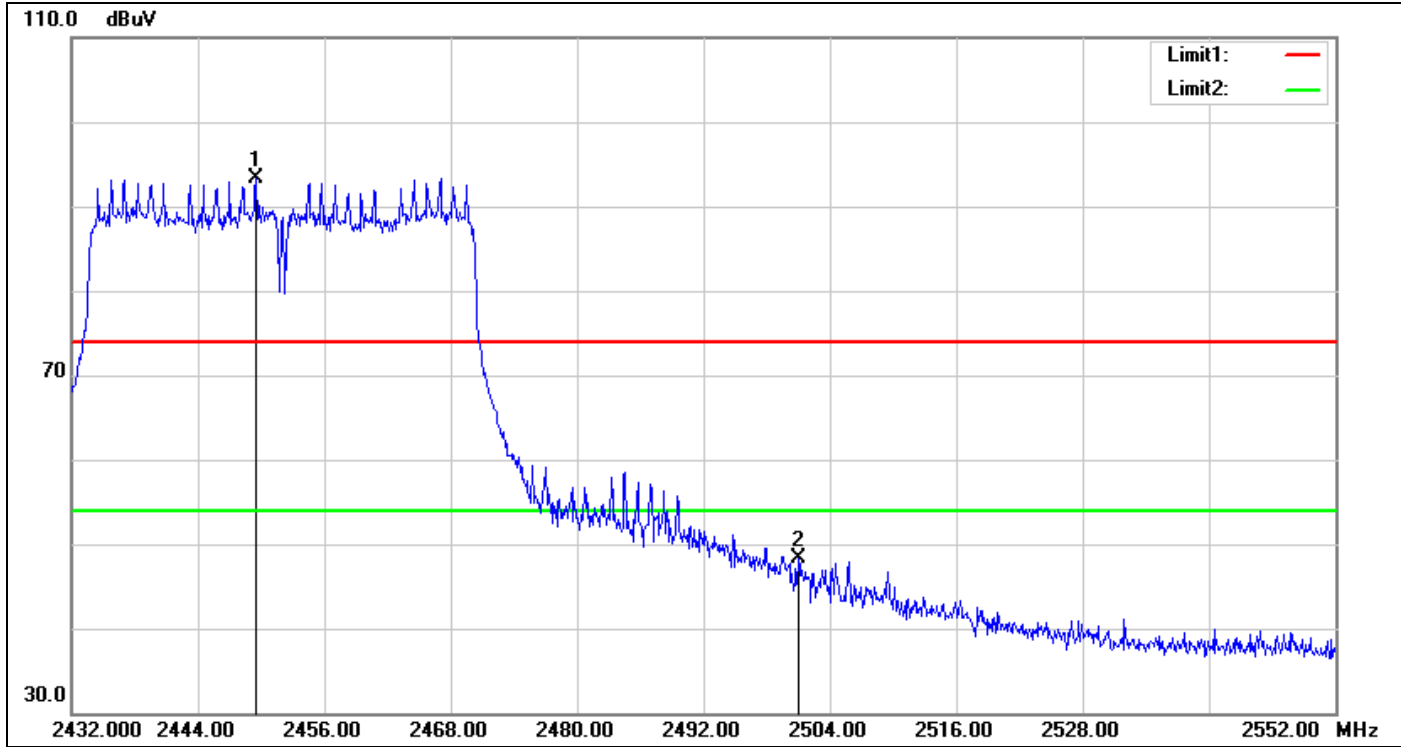

No.	Frequency (MHz)	Reading (dBuV)	Correct Factor(dB)	Result (dBuV)	Limit (dBuV)	Margin (dB)	Remark
1	2449.520	95.48	-2.14	93.34	74.00	19.34	peak
2	2501.000	50.08	-1.86	48.22	74.00	-25.78	peak

**Note: Spurious emission levels that exceed the level of 20 dB below the applicable limit.**

## 7.6 PEAK POWER SPECTRAL DENSITY

### LIMIT

1. According to §15.247(e) & RSS-247, for digitally modulated systems, the power spectral density conducted from the intentional radiator to the antenna shall not be greater than 8 dBm in any 3 kHz band during any time interval of continuous transmission.
2. According to §15.247(f) & RSS-247, the digital modulation operation of the hybrid system, with the frequency hopping turned off, shall comply with the power density requirements of paragraph (d) of this section.

### Test Configuration

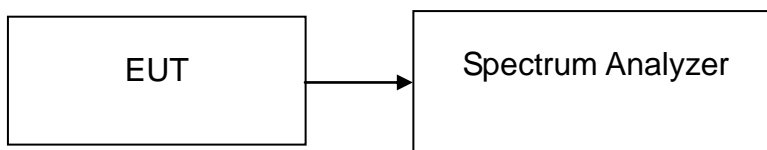

### TEST PROCEDURE

1. Place the EUT on the table and set it in transmitting mode. Remove the antenna from the EUT and then connect a low loss RF cable from the antenna port to the spectrum analyzer.
2. Set the spectrum analyzer as RBW = 3 kHz, VBW = 30 kHz, Span = 1.5MHz, Sweep time = 100 s
3. Record the max reading.
4. Repeat the above procedure until the measurements for all frequencies are completed.

### TEST RESULTS

*No non-compliance noted*



**Test Data****IEEE 802.11b mode**

Channel	Frequency (MHz)	PPSD (dBm)	Limit (dBm)	Result
Low	2412	-5.52	8.00	PASS
Mid	2437	-5.46		PASS
High	2462	-6.65		PASS

**IEEE 802.11g mode**

Channel	Frequency (MHz)	PPSD (dBm)	Limit (dBm)	Result
Low	2412	-10.02	8.00	PASS
Mid	2437	-10.24		PASS
High	2462	-10.91		PASS

**IEEE 802.11n HT 20 MHz mode**

Channel	Frequency (MHz)	PPSD (dBm)	Limit (dBm)	Result
Low	2412	-13.02	8.00	PASS
Mid	2437	-12.61		PASS
High	2462	-12.89		PASS

**IEEE 802.11n HT 40 MHz mode**

Channel	Frequency (MHz)	PPSD (dBm)	Limit (dBm)	Result
Low	2422	-16.77	8.00	PASS
Mid	2437	-14.91		PASS
High	2452	-16.46		PASS

### Test Plot

### IEEE 802.11b mode

### PPSD (CH Low)

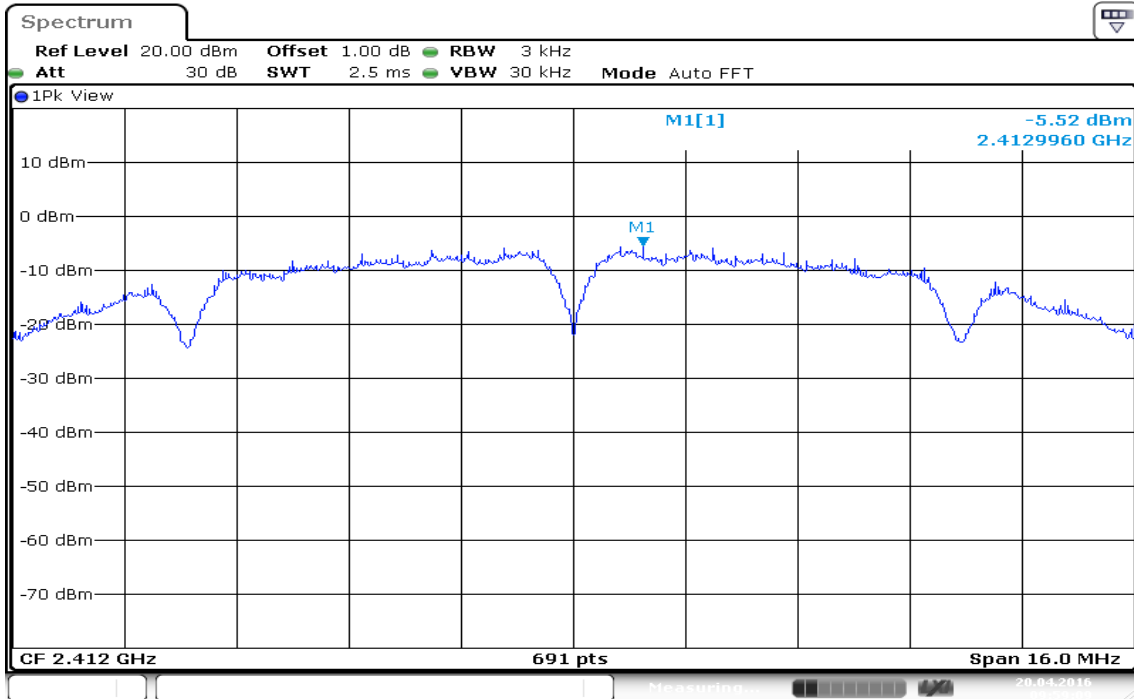

Date: 20.APR.2016 09:59:09

### PPSD (CH Mid)

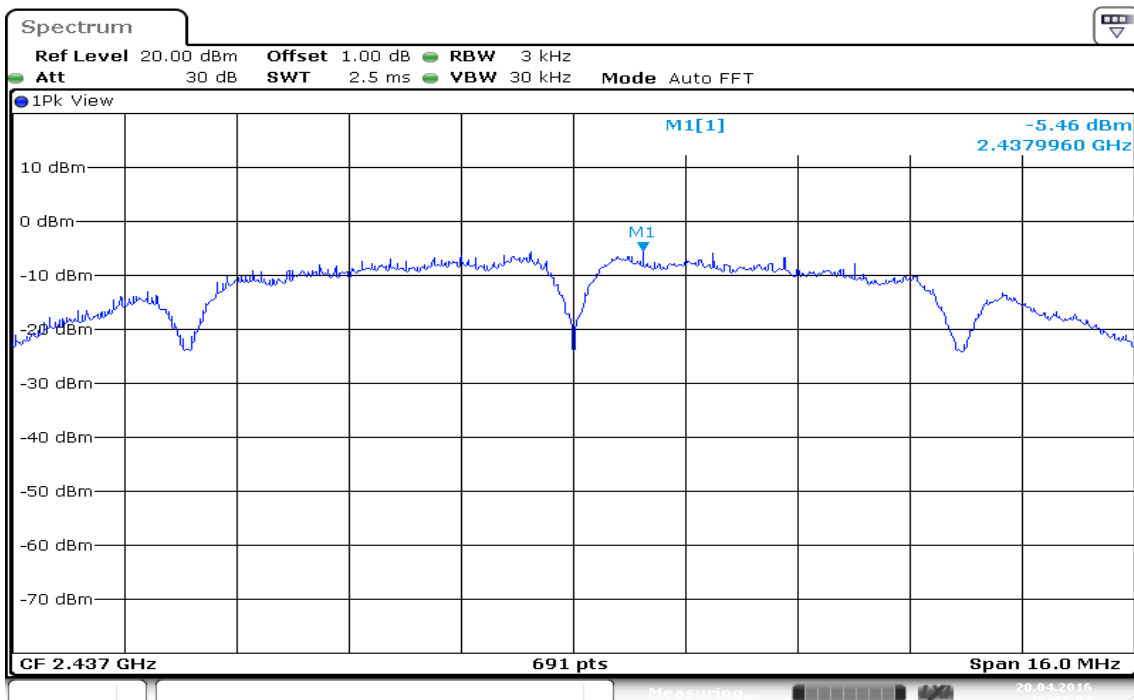

Date: 20.APR.2016 10:02:04

### PPSD (CH High)

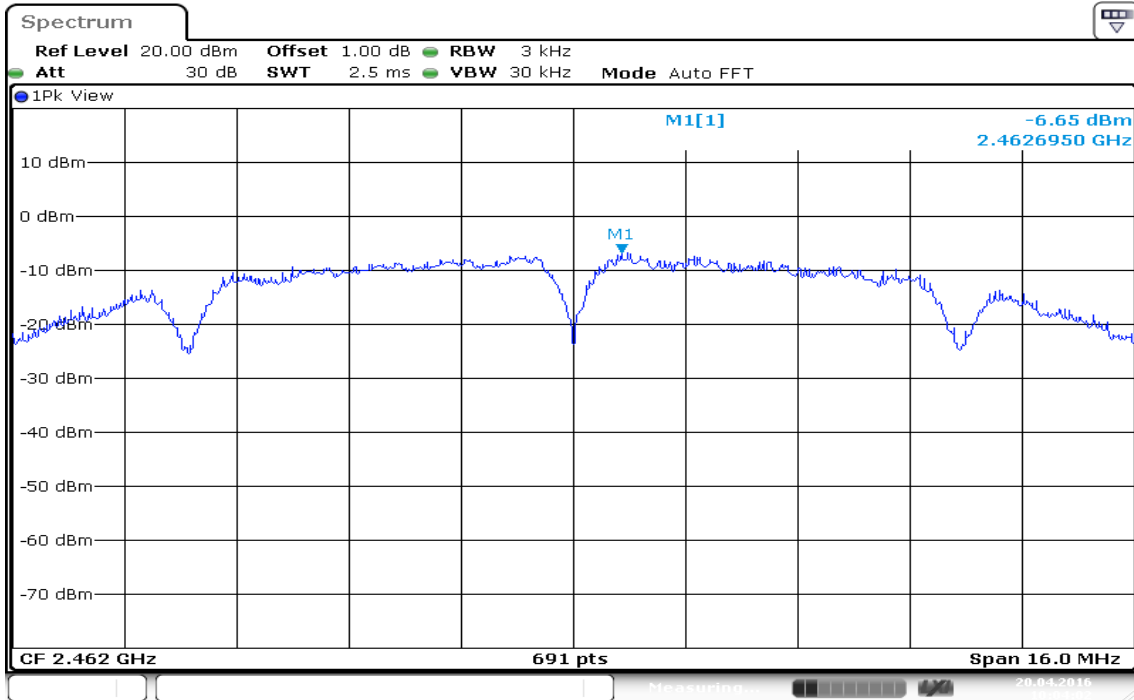

Date: 20.APR.2016 10:04:02

### IEEE 802.11g mode

### PPSD (CH Low)

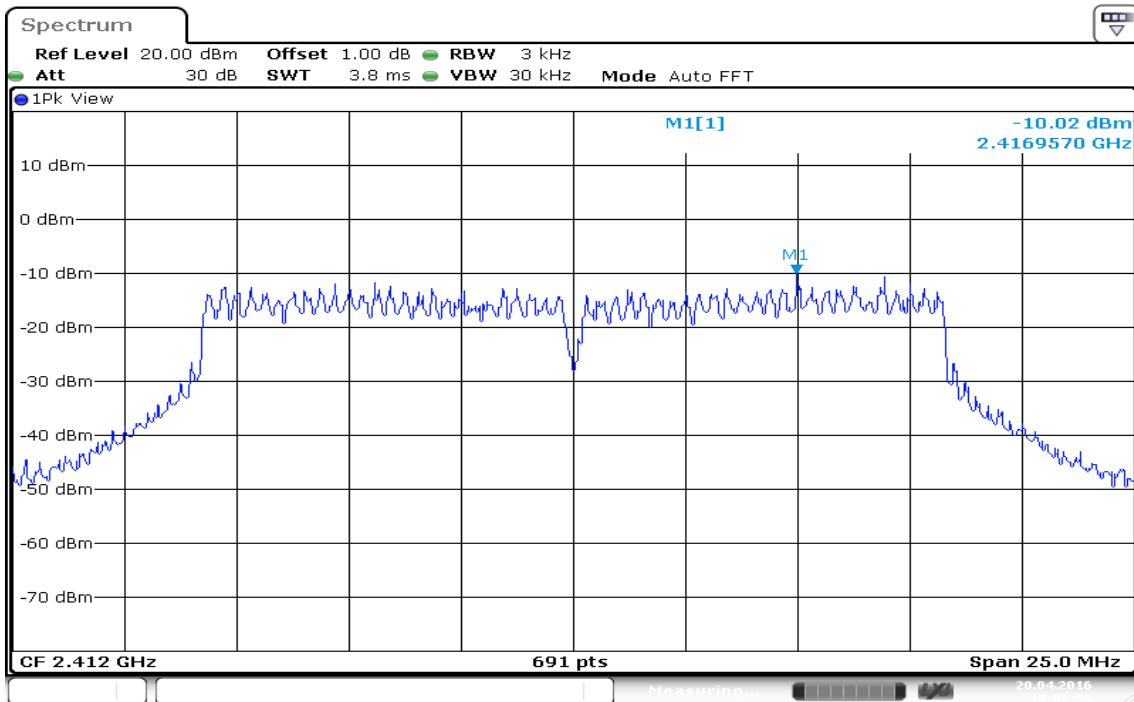

### PPSD (CH Mid)

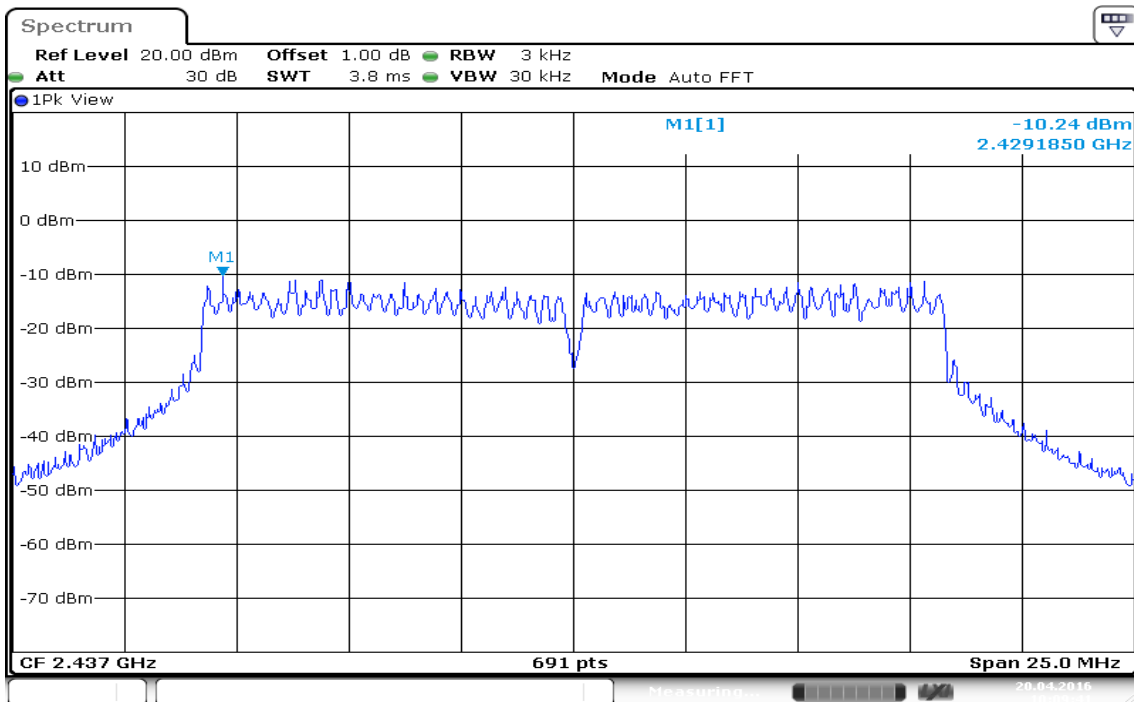

### PPSD (CH High)

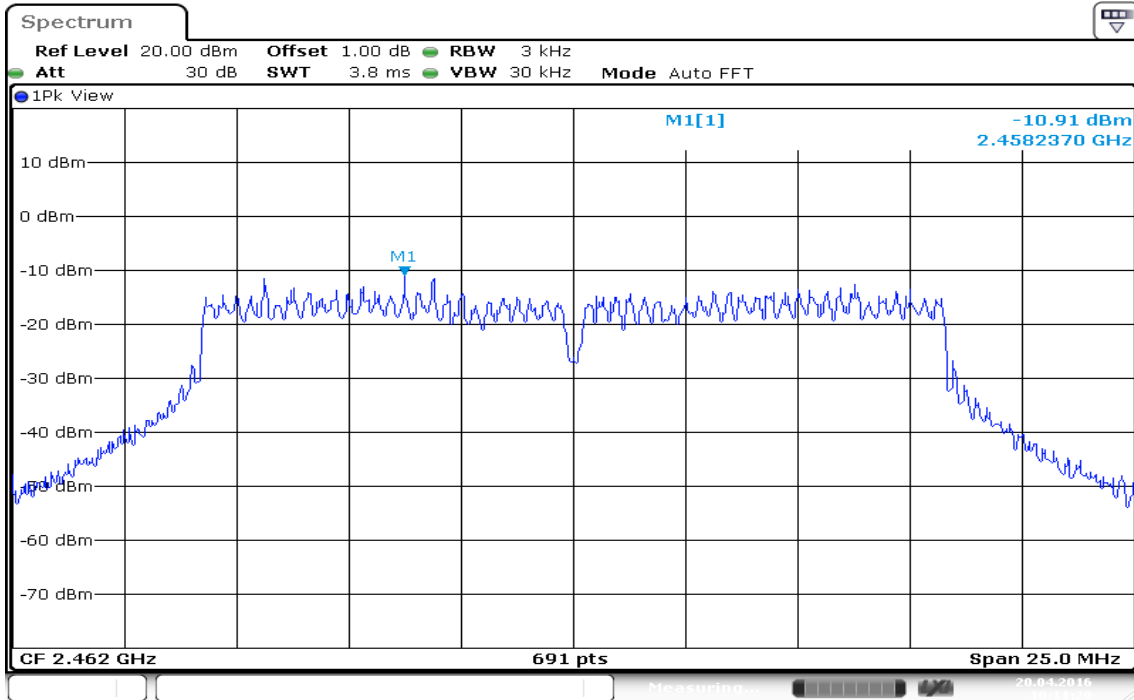

Date: 20.APR.2016 10:11:20

### IEEE 802.11n HT 20 MHz mode

### PPSD (CH Low)

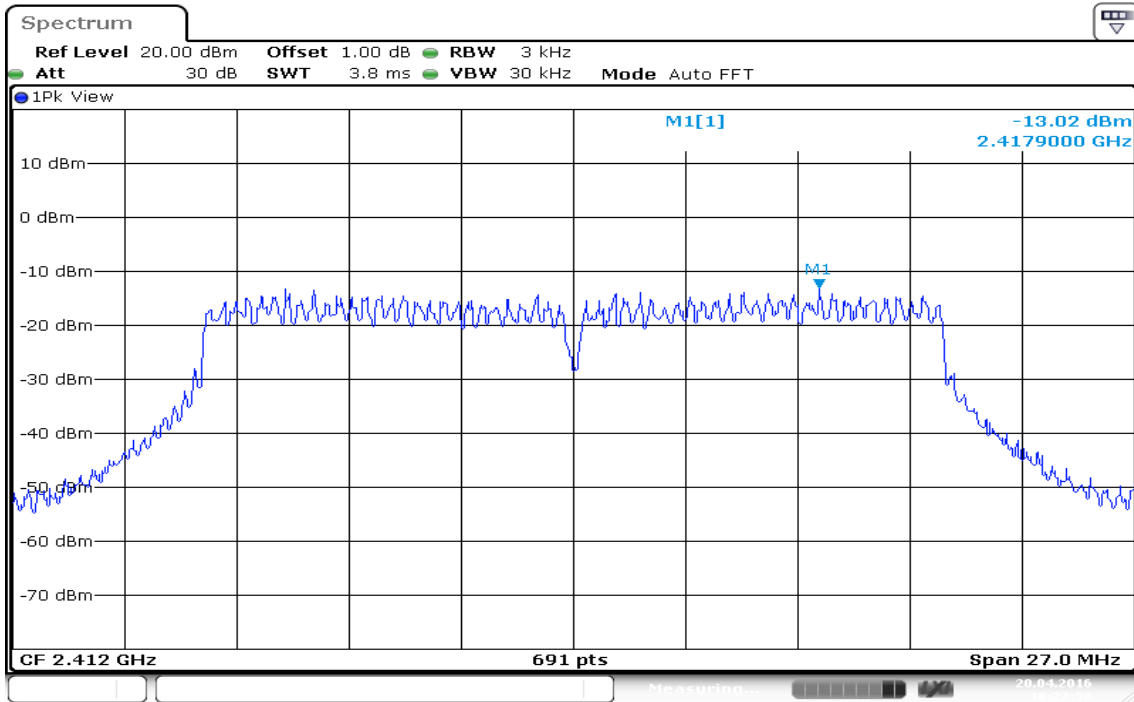

### PPSD (CH Mid)

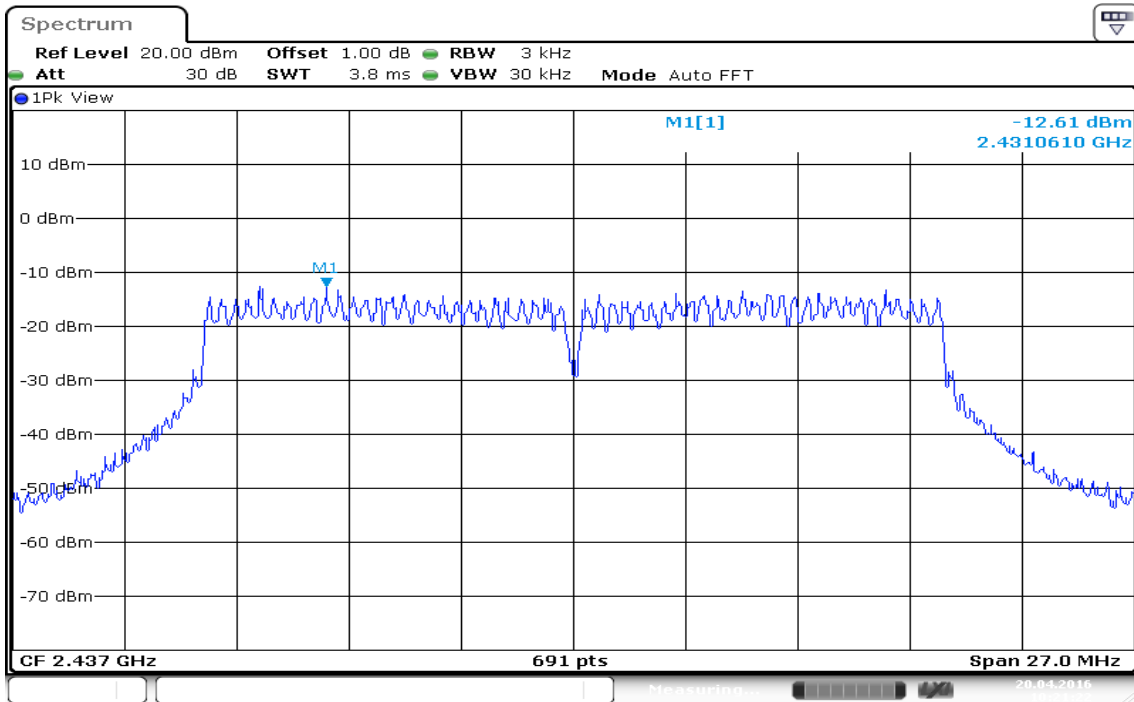

### PPSD (CH High)

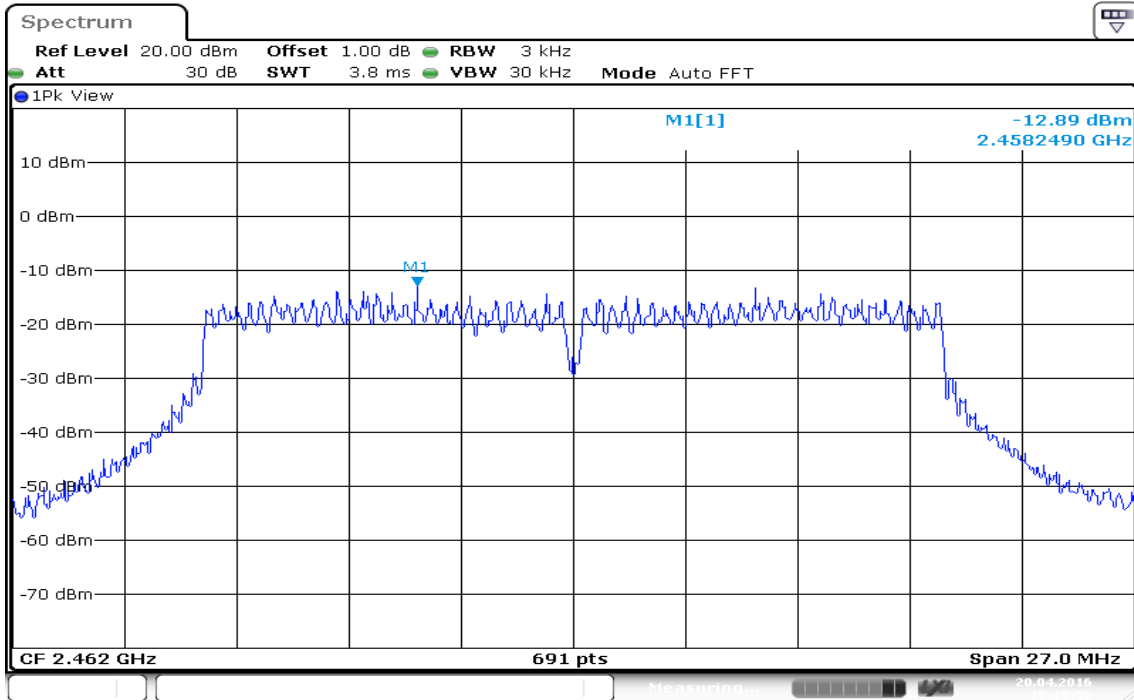

Date: 20.APR.2016 10:19:56

### IEEE 802.11n HT 40 MHz mode

### PPSD (CH Low)

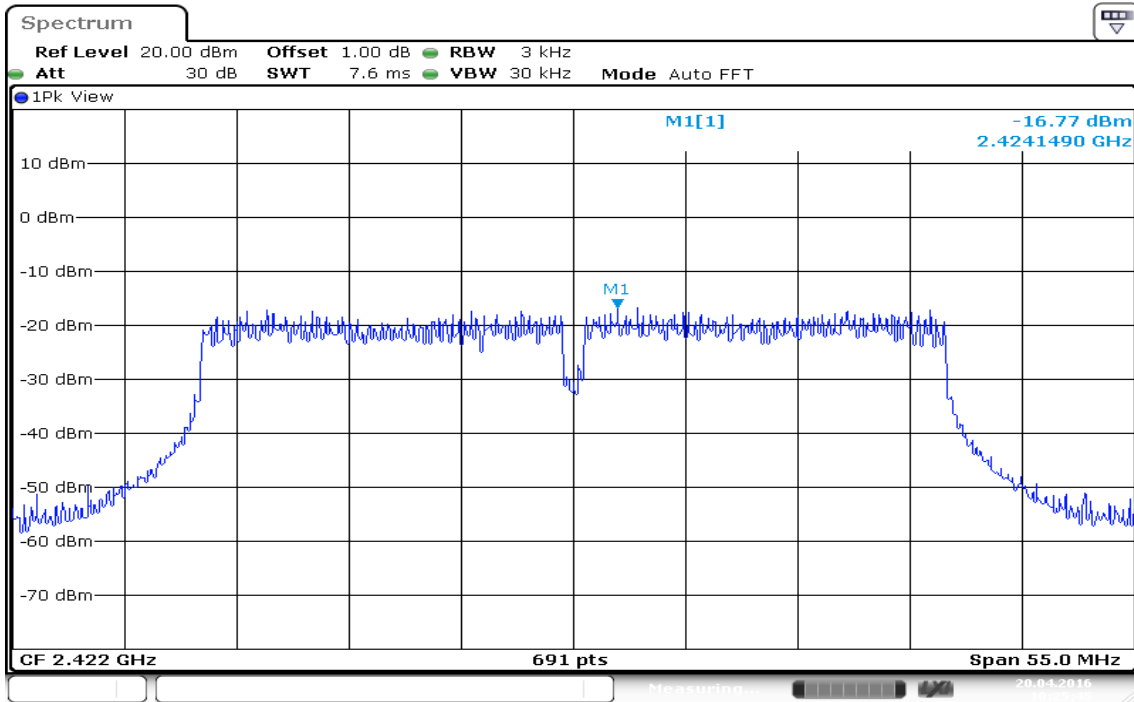

### PPSD (CH Mid)

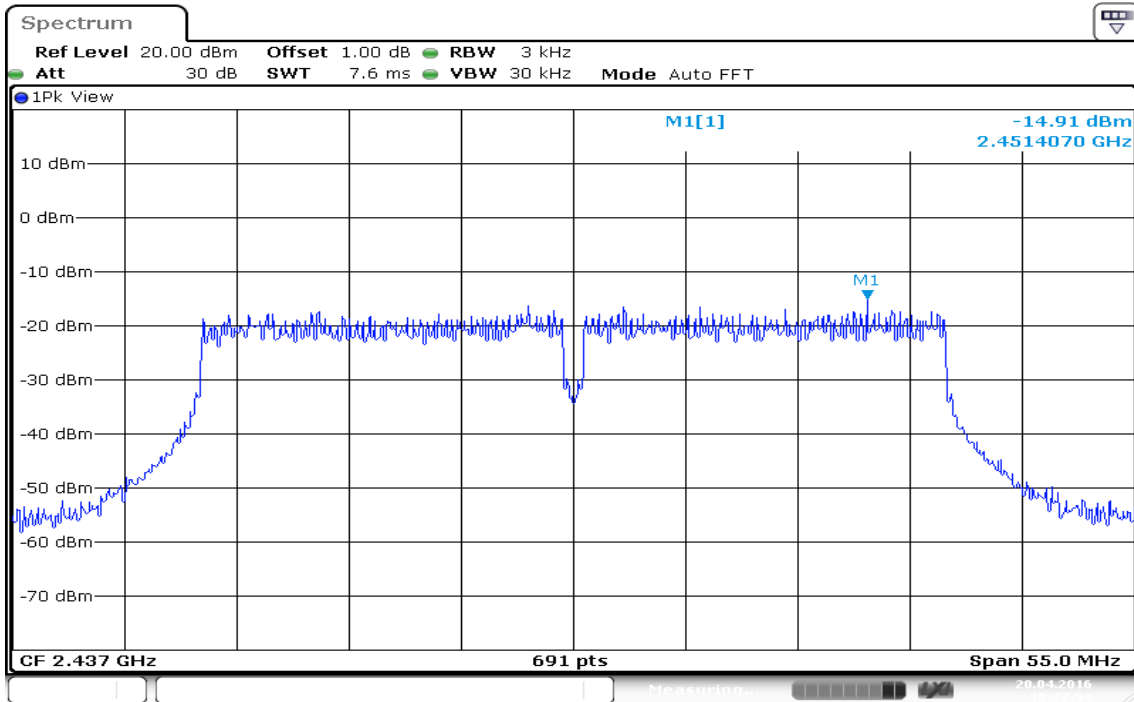



### PPSD (CH High)

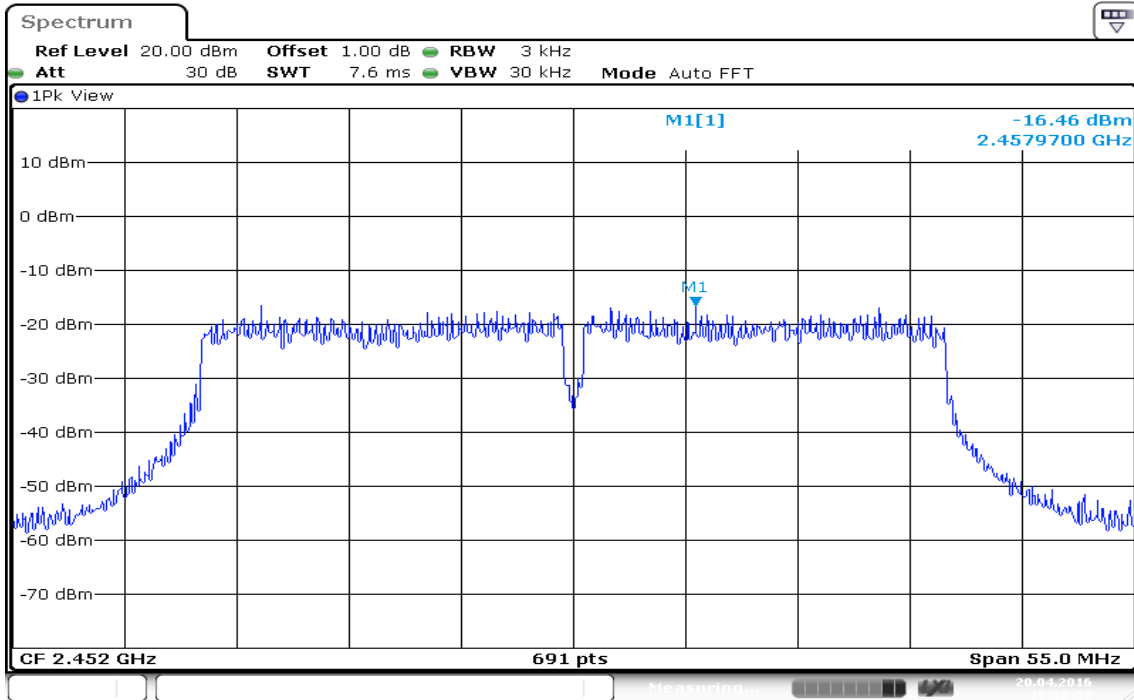

Date: 20.APR.2016 10:30:05

## 7.7 RADIATED EMISSIONS

### LIMIT

All spurious emissions shall comply with the limits of §15.209(a) and RSS-Gen Table 2 & Table 5.

### RSS-Gen Table 2 & Table 5: General Field Strength Limits for Transmitters and Receivers at Frequencies Above 30 MHz <sup>(Note)</sup>

Frequency (MHz)	Field Strength microvolts/m at 3 metres (watts, e.i.r.p.)	
	Transmitters	Receivers
30-88	100 (3 nW)	100 (3 nW)
88-216	150 (6.8 nW)	150 (6.8 nW)
216-960	200 (12 nW)	200 (12 nW)
Above 960	500 (75 nW)	500 (75 nW)

**Note:** \*Measurements for compliance with limits in the above table may be performed at distances other than 3 metres, in accordance with Section 7.2.7.

Transmitting devices are not permitted in Table 1 bands or, unless stated otherwise, in TV bands (54-72 MHz, 76-88 MHz, 174-216 MHz, 470-608 MHz and 614-806 MHz).

### RSS-Gen Table 6: General Field Strength Limits for Transmitters at Frequencies Below 30 MHz (Transmit)

Frequency	Field Strength (microvolts/m)	Magnetic H-Field (microamperes/m)	Measurement Distance (metres)
9-490 kHz	2,400/F (F in kHz)	2,400/377F (F in kHz)	3000
490-1,705 kHz	24,000/F (F in kHz)	24,000/377F (F in kHz)	30
1.705-30 MHz	30	N/A	30

**Note:** The emission limits for the bands 9-90 kHz and 110-490 kHz are based on measurements employing an average detector.

**Test Configuration**

**9kHz ~ 30MHz**

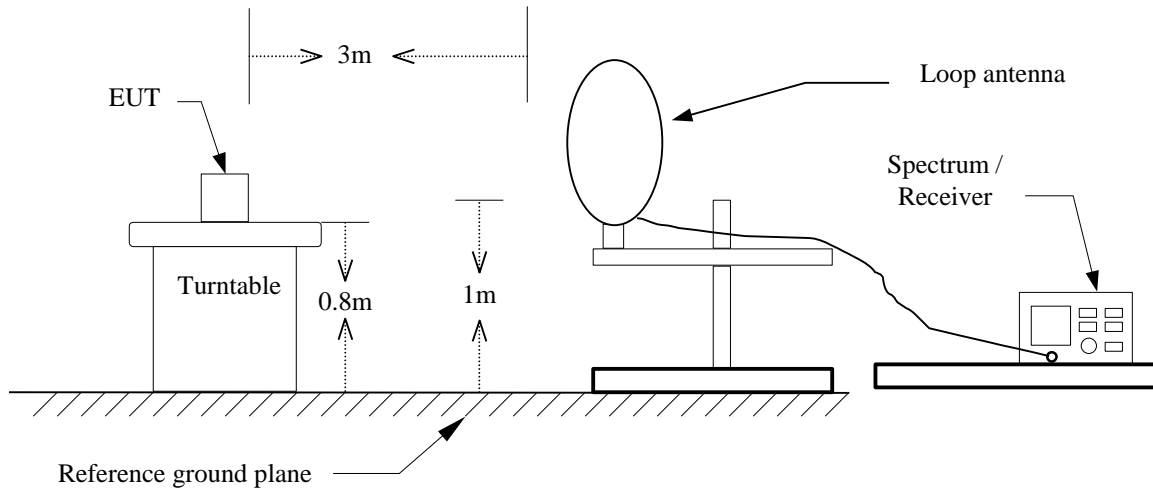

**30MHz ~ 1GHz**

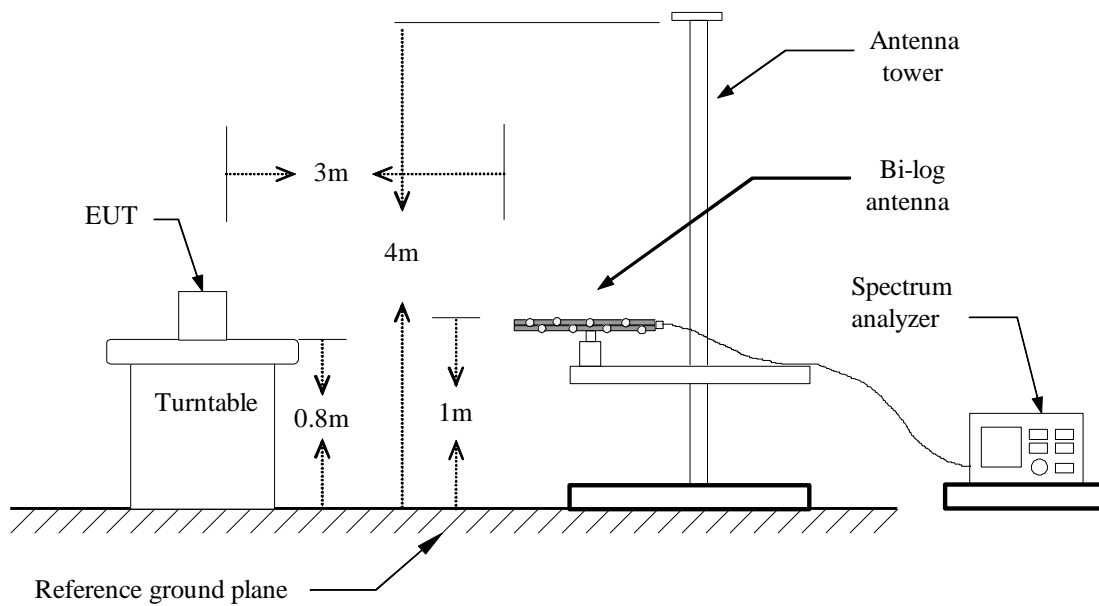

**Above 1 GHz**

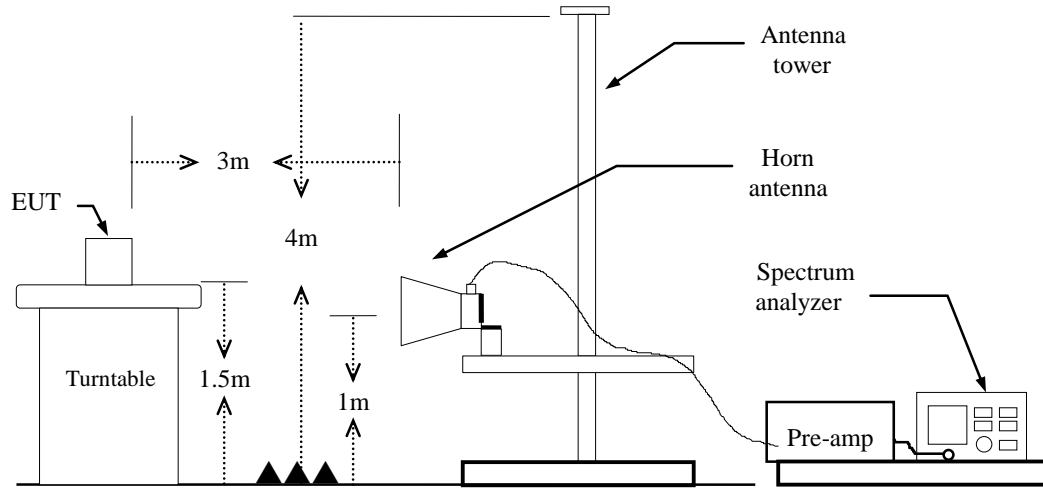

## **TEST PROCEDURE**

1. The EUT is placed on a turntable, Above 1 GHz is 1.5m high and below 1 GHz is 0.8m high above ground plane.
2. The turntable shall be rotated for 360 degrees to determine the position of maximum emission level.
3. EUT is set 3m away from the receiving antenna, which is varied from 1m to 4m to find out the highest emissions.
4. Maximum procedure was performed on the six highest emissions to ensure EUT compliance.
5. And also, each emission was to be maximized by changing the polarization of receiving antenna both horizontal and vertical.
6. Set the spectrum analyzer in the following setting as:

Below 1GHz:

RBW=100kHz / VBW=300kHz / Sweep=AUTO

Above 1GHz:

(a) PEAK: RBW=1MHz / VBW=3MHz / Sweep=AUTO

(b) AVERAGE: RBW=1MHz,  
if duty cycle  $\geq 98\%$ , VBW=10Hz.  
if duty cycle  $< 98\%$  VBW=1/T.

**IEEE 802.11b mode:**  $\geq 98\%$ , VBW=10Hz

**IEEE 802.11g mode:**  $\geq 96\%$ , VBW=510Hz

**IEEE 802.11n HT 20 MHz mode:**  $\geq 98\%$ , VBW=10Hz

**IEEE 802.11n HT 40 MHz mode:**  $\geq 98\%$ , VBW=10Hz

7. Repeat above procedures until the measurements for all frequencies are complete.
8. Result = Spectrum Reading + cable loss(spectrum to Amp) - Amp Gain + Cable loss(Amp to receive Ant)+ Receive Ant

**Note:** We checked every harmonics frequencies from Fundamental frequencies with reduced VBW, and we mark a point to prove pass or not if we find any emission. For this case, there are no emissions hidden in the noise floor.

**Below 1GHz**

**Operation Mode:** Normal Link

**Test Date:** April 25, 2016

**Temperature:** 27°C

**Tested by:** Dennis Li

**Humidity:** 53% RH

**Polarity:** Ver.

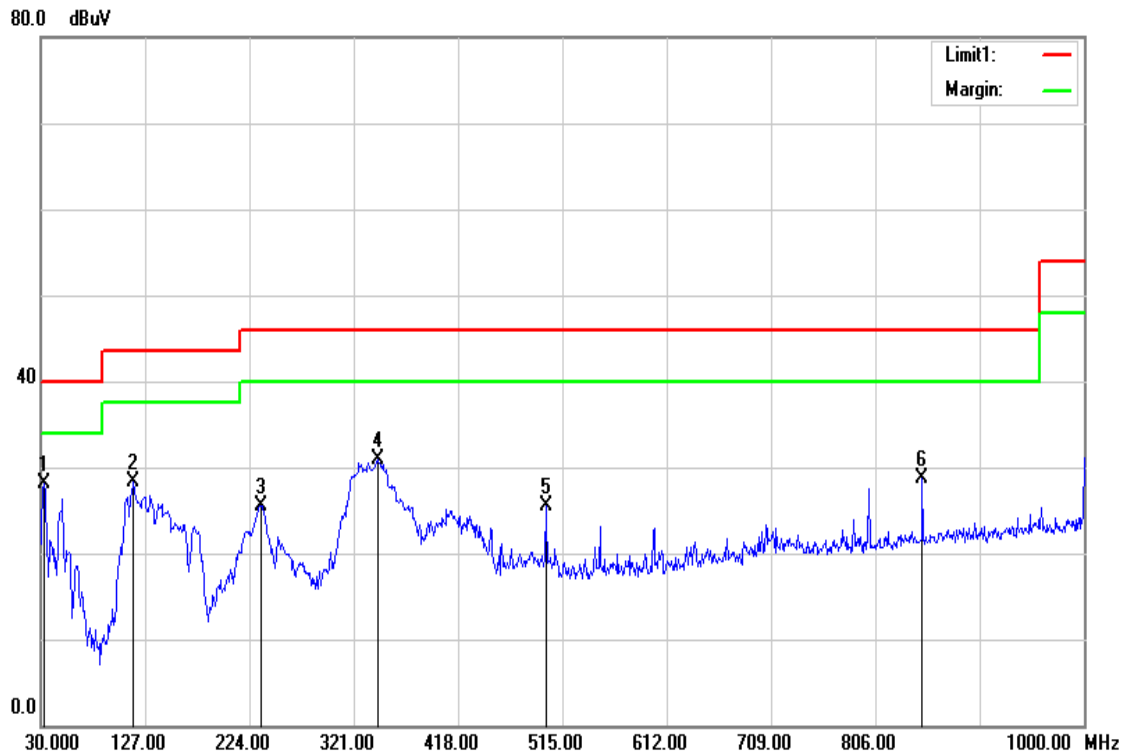

Frequency (MHz)	Reading (dBuV)	Correction Factor (dB/m)	Result (dBuV/m)	Limit (dBuV/m)	Margin (dB)	Remark	Ant. Pol. (H/V)
32.9100	38.10	-10.07	28.03	40.00	-11.97	peak	V
116.3300	44.37	-16.15	28.22	43.50	-15.28	peak	V
234.6700	42.20	-16.63	25.57	46.00	-20.43	peak	V
343.3100	43.93	-13.07	30.86	46.00	-15.14	peak	V
499.4800	34.77	-9.25	25.52	46.00	-20.48	peak	V
849.6500	32.41	-3.79	28.62	46.00	-17.38	peak	V

**Remark:**

1. Measuring frequencies from 30 MHz to the 1GHz.
2. Radiated emissions measured in frequency range from 30 MHz to 1000MHz were made with an instrument using peak/quasi-peak detector mode.
3. Quasi-peak test would be performed if the peak result were greater than the quasi-peak limit or as required by the applicant.
4. Measurements above show only up to 6 maximum emissions noted, or would be lesser, with " N/A " remark, if no specific emissions from the EUT are recorded (ie: margin>20dB from the applicable limit) and considered that's already beyond the background noise floor.
5. Margin (dB) = Result (dBuV/m) – Limit (dBuV/m).

**Operation Mode:** Normal Link

**Test Date:** April 25, 2016

**Temperature:** 27°C

**Tested by:** Dennis Li

**Humidity:** 53% RH

**Polarity:** Hor.

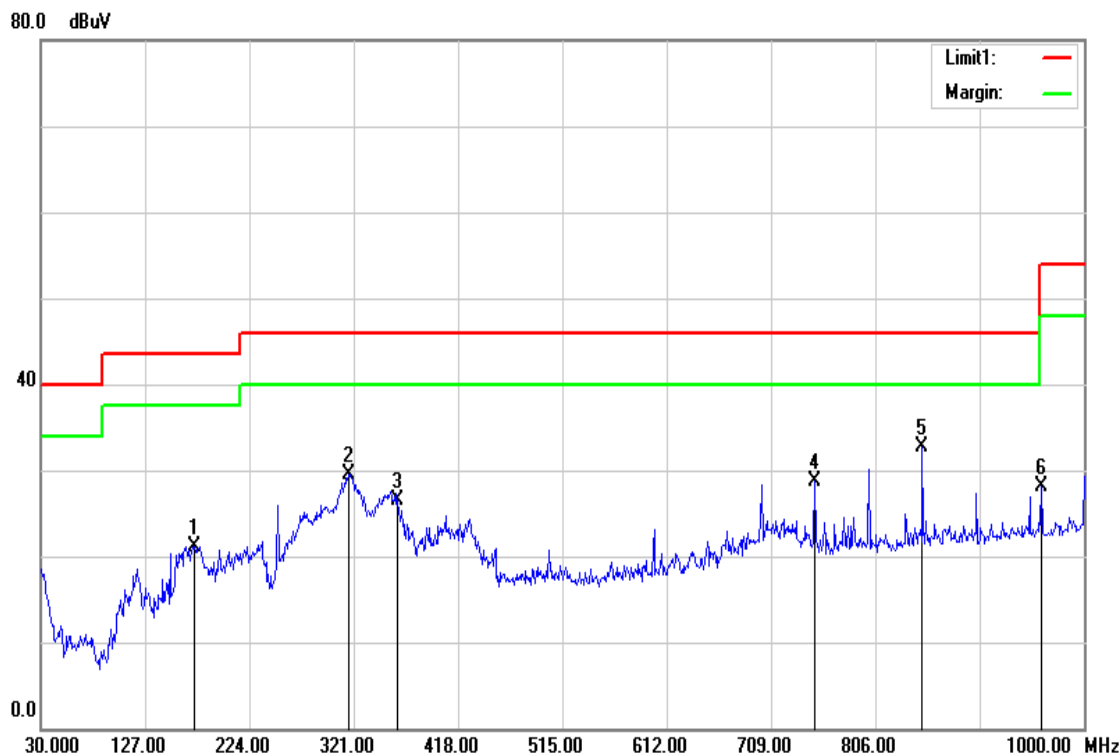

Frequency (MHz)	Reading (dBuV)	Correction Factor (dB/m)	Result (dBuV/m)	Limit (dBuV/m)	Margin (dB)	Remark	Ant. Pol. (H/V)
172.5900	38.10	-16.98	21.12	43.50	-22.38	peak	H
316.1500	43.39	-13.80	29.59	46.00	-16.41	peak	H
361.7400	39.14	-12.61	26.53	46.00	-19.47	peak	H
749.7400	33.54	-4.93	28.61	46.00	-17.39	peak	H
849.6500	36.55	-3.79	32.76	46.00	-13.24	peak	H
960.2300	30.34	-2.23	28.11	54.00	-25.89	peak	H

**Remark:**

1. Measuring frequencies from 30 MHz to the 1GHz.
2. Radiated emissions measured in frequency range from 30 MHz to 1000MHz were made with an instrument using peak/quasi-peak detector mode.
3. Quasi-peak test would be performed if the peak result were greater than the quasi-peak limit or as required by the applicant.
4. Measurements above show only up to 6 maximum emissions noted, or would be lesser, with " N/A " remark, if no specific emissions from the EUT are recorded (ie: margin>20dB from the applicable limit) and considered that's already beyond the background noise floor.
5. Margin (dB) = Result (dBuV/m) – Limit (dBuV/m).

**Above 1 GHz**

**TX / IEEE 802.11b / CH Low**

**Polarity: Vertical**

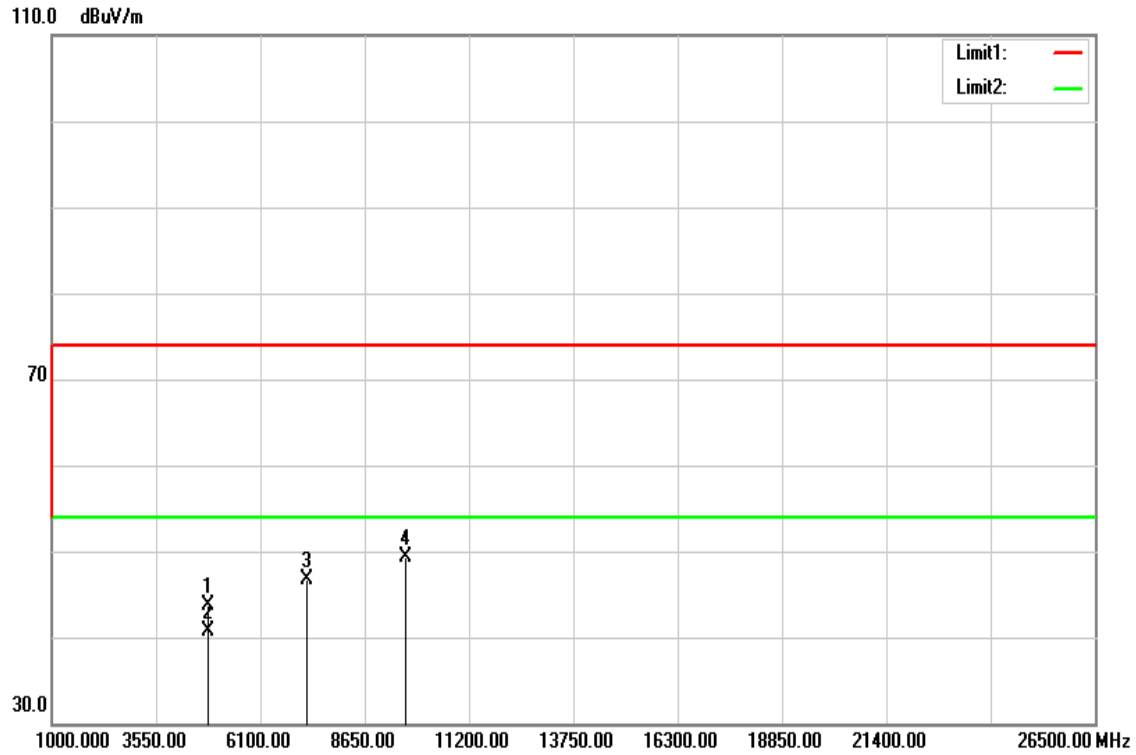

**Polarity: Horizontal**

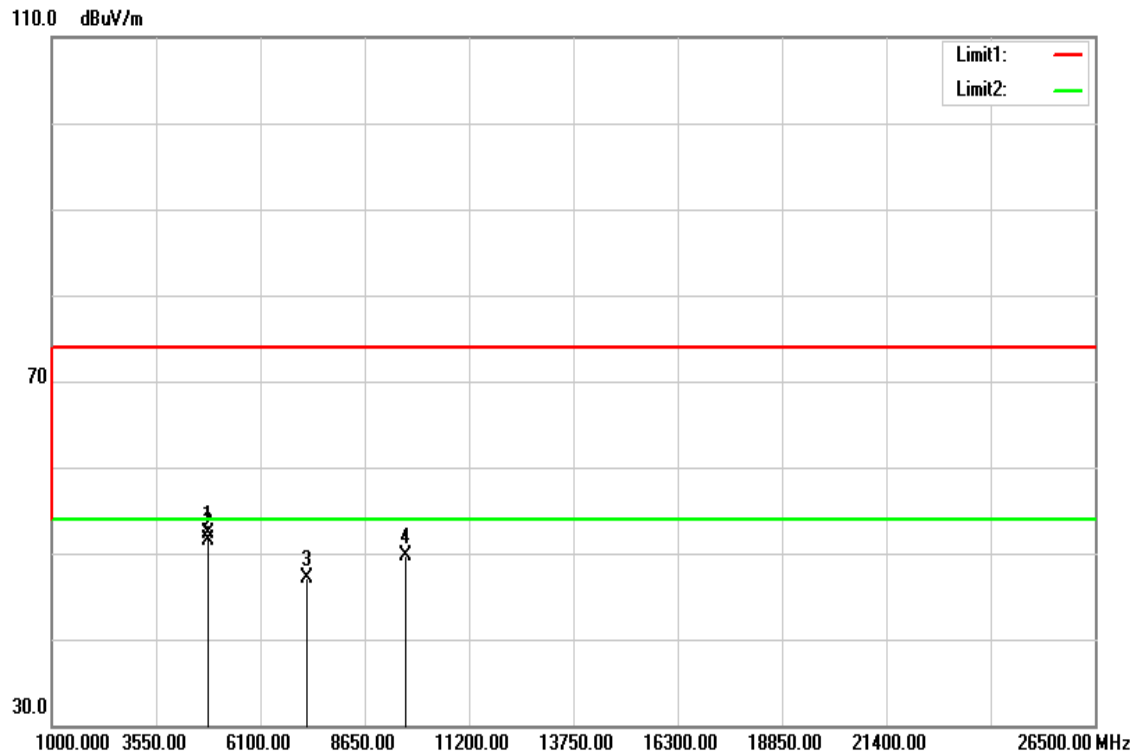



**Above 1 GHz**

**Operation Mode:** TX / IEEE 802.11b / CH Low

**Test Date:** April 28, 2016

**Temperature:** 27°C

**Tested by:** Dennis Li

**Humidity:** 53% RH

**Polarity:** Ver. / Hor.

Frequency (MHz)	Reading (dBuV)	Correction Factor (dB/m)	Result (dBuV/m)	Limit (dBuV/m)	Margin (dB)	Remark	Ant. Pol. (H/V)
4824.000	38.66	5.10	43.76	74.00	-30.24	peak	V
4824.000	35.55	5.10	40.65	54.00	-13.35	AVG	V
7236.000	34.00	12.71	46.71	74.00	-27.29	peak	V
9648.000	31.79	17.60	49.39	74.00	-24.61	peak	V
N/A							
4827.000	47.24	5.11	52.35	74.00	-21.65	peak	H
4827.000	46.31	5.11	51.42	54.00	-2.58	AVG	H
7236.000	34.44	12.71	47.15	74.00	-26.85	peak	H
9648.000	32.17	17.60	49.77	74.00	-24.23	peak	H
N/A							

**Remark:**

1. *Measuring frequencies from 1 GHz to the 10th harmonic of highest fundamental frequency.*
2. *Radiated emissions measured in frequency above 1000MHz were made with an instrument using peak/average detector mode.*
3. *Average test would be performed if the peak result were greater than the average limit or as required by the applicant.*
4. *Data of measurement within this frequency range shown " --- " in the table above means the reading of emissions are attenuated more than 20dB below the permissible limits or the field strength is too small to be measured.*
5. *Measurements above show only up to 6 maximum emissions noted, or would be lesser, with " N/A " remark, if no specific emissions from the EUT are recorded (ie: margin>20dB from the applicable limit) and considered that's already beyond the background noise floor.*
6. *Margin (dB) = Remark result (dBuV/m) – Average limit (dBuV/m).*

**TX / IEEE 802.11b / CH Mid**

**Polarity: Vertical**

110.0 dBuV/m

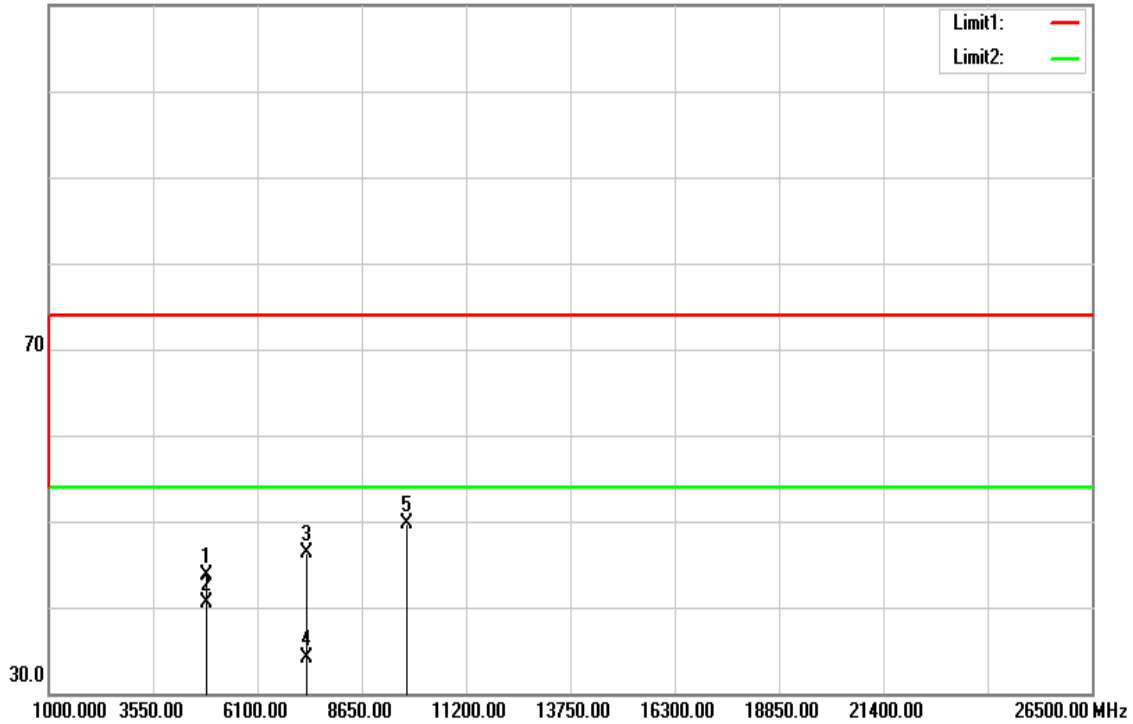

**Polarity: Horizontal**

110.0 dBuV/m

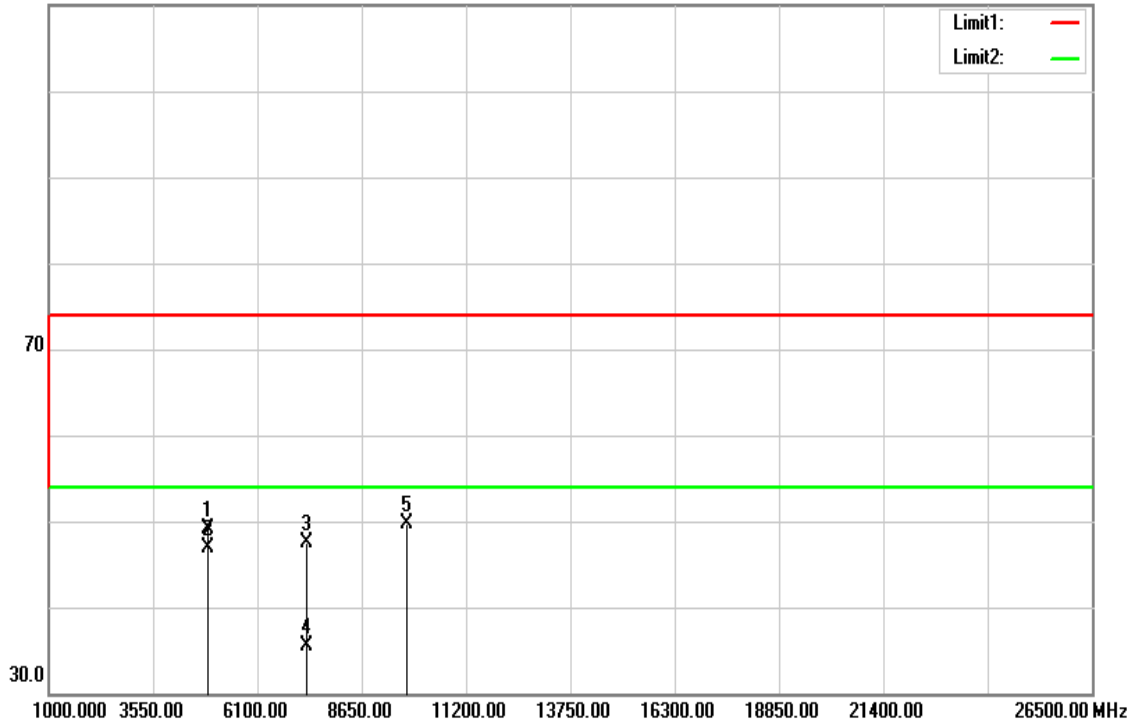

**Operation Mode:** TX / IEEE 802.11b / CH Mid

**Test Date:** April 28, 2016

**Temperature:** 27°C

**Tested by:** Dennis Li

**Humidity:** 53% RH

**Polarity:** Ver. / Hor.

Frequency (MHz)	Reading (dBuV)	Correction Factor (dB/m)	Result (dBuV/m)	Limit (dBuV/m)	Margin (dB)	Remark	Ant. Pol. (H/V)
4874.000	38.50	5.23	43.73	74.00	-30.27	peak	V
4874.000	35.29	5.23	40.52	54.00	-13.48	AVG	V
7311.000	33.43	12.94	46.37	74.00	-27.63	peak	V
7311.000	21.17	12.94	34.11	54.00	-19.89	AVG	V
9748.000	32.01	17.60	49.61	74.00	-24.39	peak	V
N/A							
4876.000	43.92	5.24	49.16	74.00	-24.84	peak	H
4876.000	41.61	5.24	46.85	54.00	-7.15	AVG	H
7311.000	34.63	12.94	47.57	74.00	-26.43	peak	H
7311.000	22.58	12.94	35.52	54.00	-18.48	AVG	H
9748.000	32.16	17.60	49.76	74.00	-24.24	peak	H
N/A							

**Remark:**

1. Measuring frequencies from 1 GHz to the 10th harmonic of highest fundamental frequency.
2. Radiated emissions measured in frequency above 1000MHz were made with an instrument using peak/average detector mode.
3. Average test would be performed if the peak result were greater than the average limit or as required by the applicant.
4. Data of measurement within this frequency range shown " --- " in the table above means the reading of emissions are attenuated more than 20dB below the permissible limits or the field strength is too small to be measured.
5. Measurements above show only up to 6 maximum emissions noted, or would be lesser, with " N/A " remark, if no specific emissions from the EUT are recorded (ie: margin>20dB from the applicable limit) and considered that's already beyond the background noise floor.
6. Margin (dB) = Remark result (dBuV/m) – Average limit (dBuV/m).

**TX / IEEE 802.11b / CH High**

**Polarity: Vertical**

110.0 dBuV/m

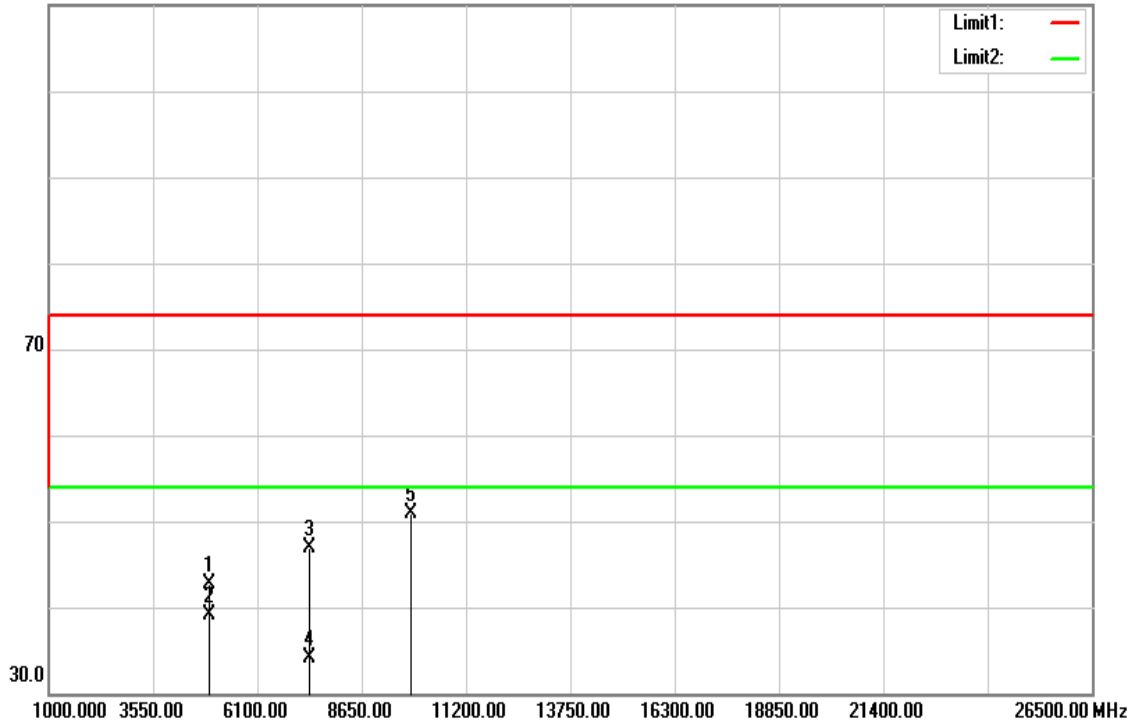

**Polarity: Horizontal**

110.0 dBuV/m

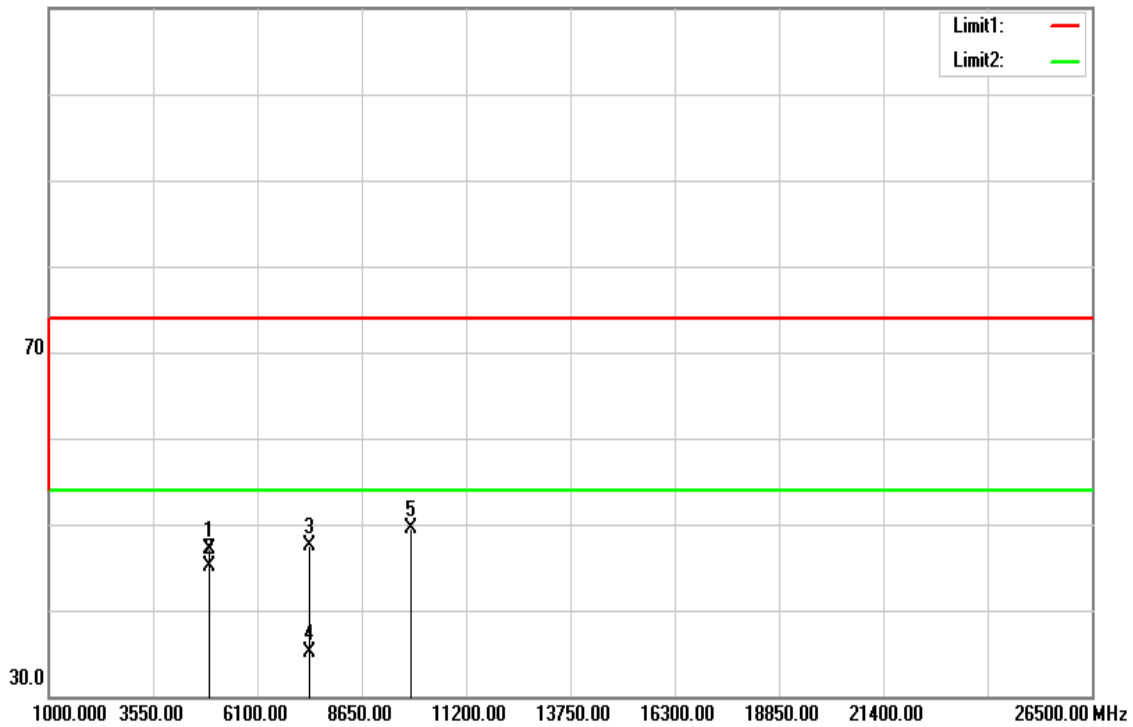

**Operation Mode:** TX / IEEE 802.11b / CH High

**Test Date:** April 28, 2016

**Temperature:** 27°C

**Tested by:** Dennis Li

**Humidity:** 53% RH

**Polarity:** Ver. / Hor.

Frequency (MHz)	Reading (dBuV)	Correction Factor (dB/m)	Result (dBuV/m)	Limit (dBuV/m)	Margin (dB)	Remark	Ant. Pol. (H/V)
4924.000	37.37	5.37	42.74	74.00	-31.26	peak	V
4924.000	33.79	5.37	39.16	54.00	-14.84	AVG	V
7386.000	33.76	13.17	46.93	74.00	-27.07	peak	V
7386.000	20.88	13.17	34.05	54.00	-19.95	AVG	V
9848.000	33.25	17.60	50.85	74.00	-23.15	peak	V
N/A							
4925.000	41.78	5.37	47.15	74.00	-26.85	peak	H
4925.000	39.74	5.37	45.11	54.00	-8.89	AVG	H
7386.000	34.41	13.17	47.58	74.00	-26.42	peak	H
7386.000	21.94	13.17	35.11	54.00	-18.89	AVG	H
9848.000	31.97	17.60	49.57	74.00	-24.43	peak	H
N/A							

**Remark:**

1. Measuring frequencies from 1 GHz to the 10th harmonic of highest fundamental frequency.
2. Radiated emissions measured in frequency above 1000MHz were made with an instrument using peak/average detector mode.
3. Average test would be performed if the peak result were greater than the average limit or as required by the applicant.
4. Data of measurement within this frequency range shown " --- " in the table above means the reading of emissions are attenuated more than 20dB below the permissible limits or the field strength is too small to be measured.
5. Measurements above show only up to 6 maximum emissions noted, or would be lesser, with " N/A " remark, if no specific emissions from the EUT are recorded (ie: margin>20dB from the applicable limit) and considered that's already beyond the background noise floor.
6. Margin (dB) = Remark result (dBuV/m) – Average limit (dBuV/m).

**TX / IEEE 802.11g / CH Low**

**Polarity: Vertical**

110.0 dBuV/m

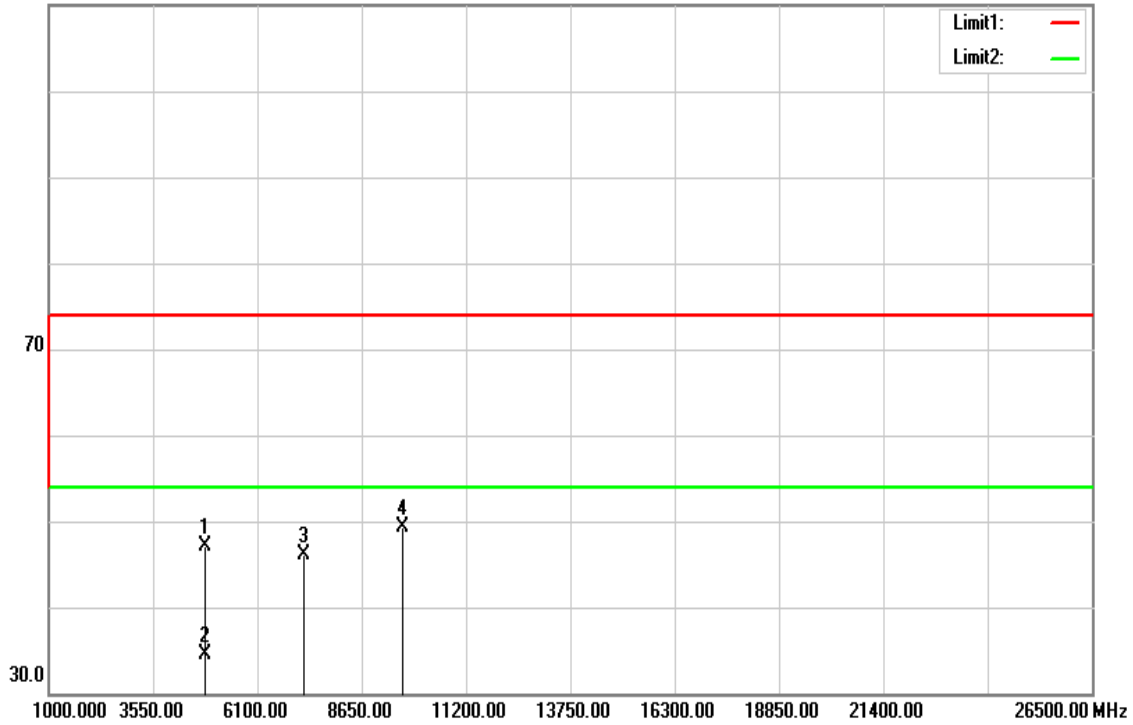

**Polarity: Horizontal**

110.0 dBuV/m

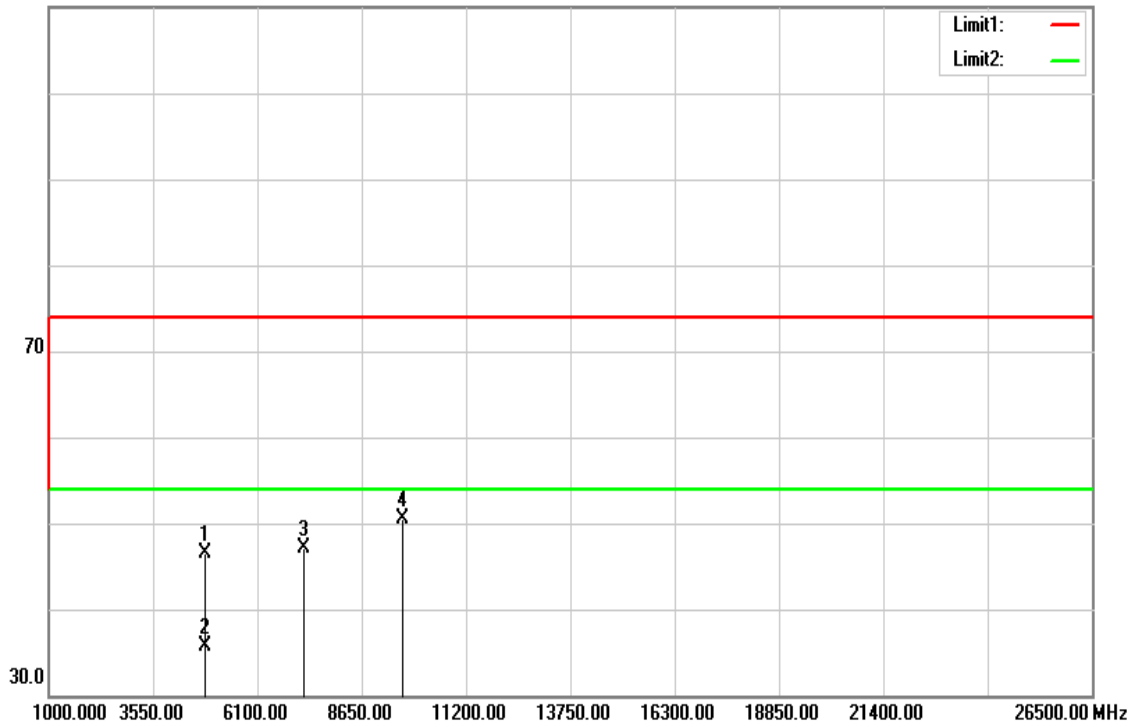

**Operation Mode:** TX / IEEE 802.11g / CH Low

**Test Date:** April 28, 2016

**Temperature:** 27°C

**Tested by:** Dennis Li

**Humidity:** 53% RH

**Polarity:** Ver. / Hor.

Frequency (MHz)	Reading (dBuV)	Correction Factor (dB/m)	Result (dBuV/m)	Limit (dBuV/m)	Margin (dB)	Remark	Ant. Pol. (H/V)
4827.000	41.99	5.11	47.10	74.00	-26.90	peak	V
4827.000	29.47	5.11	34.58	54.00	-19.42	AVG	V
7236.000	33.30	12.71	46.01	74.00	-27.99	peak	V
9648.000	31.72	17.60	49.32	74.00	-24.68	peak	V
N/A							
4820.000	41.38	5.09	46.47	74.00	-27.53	peak	H
4820.000	30.54	5.09	35.63	54.00	-18.37	AVG	H
7236.000	34.37	12.71	47.08	74.00	-26.92	peak	H
9648.000	32.91	17.60	50.51	74.00	-23.49	peak	H
N/A							

**Remark:**

1. *Measuring frequencies from 1 GHz to the 10th harmonic of highest fundamental frequency.*
2. *Radiated emissions measured in frequency above 1000MHz were made with an instrument using peak/average detector mode.*
3. *Average test would be performed if the peak result were greater than the average limit or as required by the applicant.*
4. *Data of measurement within this frequency range shown " --- " in the table above means the reading of emissions are attenuated more than 20dB below the permissible limits or the field strength is too small to be measured.*
5. *Measurements above show only up to 6 maximum emissions noted, or would be lesser, with " N/A " remark, if no specific emissions from the EUT are recorded (ie: margin>20dB from the applicable limit) and considered that's already beyond the background noise floor.*
6. *Margin (dB) = Remark result (dBuV/m) – Average limit (dBuV/m).*

**TX / IEEE 802.11g / CH Mid**

**Polarity: Vertical**

110.0 dBuV/m

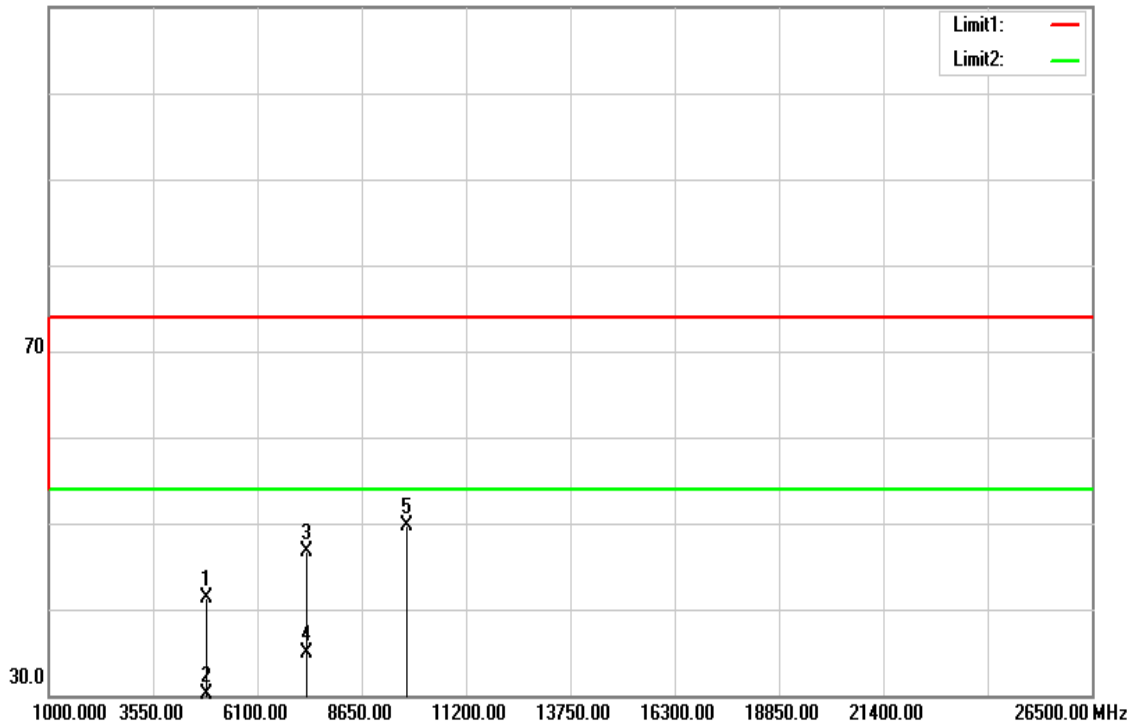

**Polarity: Horizontal**

110.0 dBuV/m

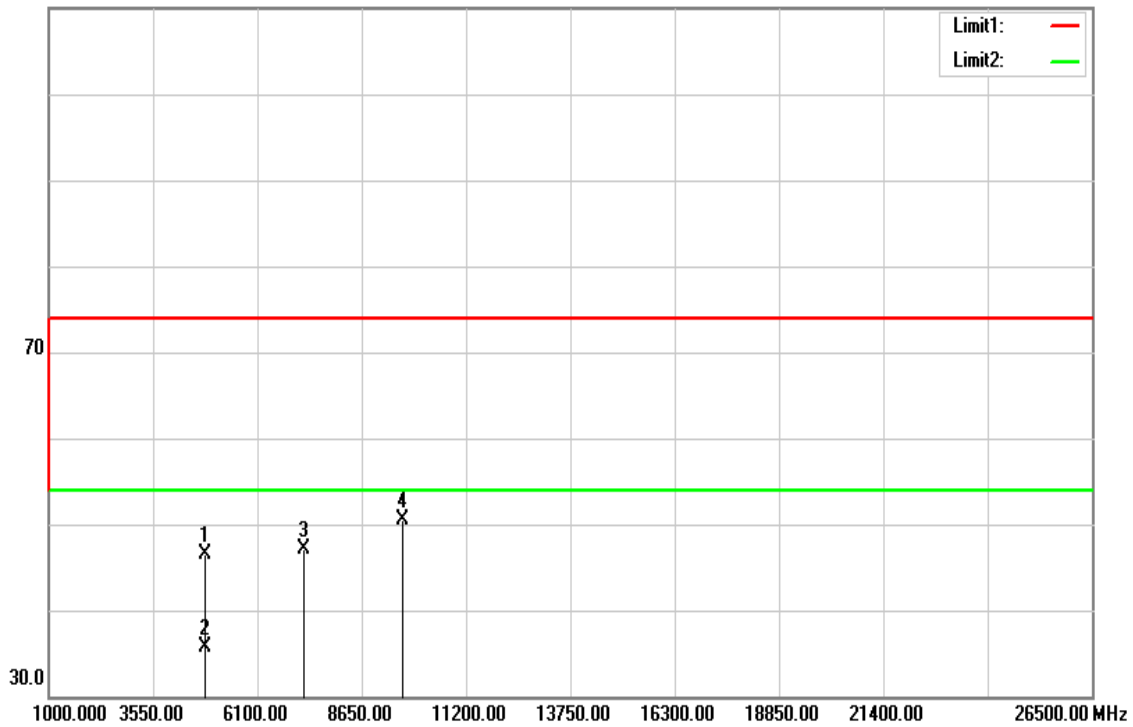



**Operation Mode:** TX / IEEE 802.11g / CH Mid

**Test Date:** April 28, 2016

**Temperature:** 27°C

**Tested by:** Dennis Li

**Humidity:** 53% RH

**Polarity:** Ver. / Hor.

Frequency (MHz)	Reading (dBuV)	Correction Factor (dB/m)	Result (dBuV/m)	Limit (dBuV/m)	Margin (dB)	Remark	Ant. Pol. (H/V)
4874.000	36.11	5.23	41.34	74.00	-32.66	peak	V
4874.000	24.93	5.23	30.16	54.00	-23.84	AVG	V
7311.000	33.68	12.94	46.62	74.00	-27.38	peak	V
7311.000	22.02	12.94	34.96	54.00	-19.04	AVG	V
9748.000	32.03	17.60	49.63	74.00	-24.37	peak	V
N/A							
4820.000	41.38	5.09	46.47	74.00	-27.53	peak	H
4820.000	30.54	5.09	35.63	54.00	-18.37	AVG	H
7236.000	34.37	12.71	47.08	74.00	-26.92	peak	H
9648.000	32.91	17.60	50.51	74.00	-23.49	peak	H
N/A							

**Remark:**

1. *Measuring frequencies from 1 GHz to the 10th harmonic of highest fundamental frequency.*
2. *Radiated emissions measured in frequency above 1000MHz were made with an instrument using peak/average detector mode.*
3. *Average test would be performed if the peak result were greater than the average limit or as required by the applicant.*
4. *Data of measurement within this frequency range shown " --- " in the table above means the reading of emissions are attenuated more than 20dB below the permissible limits or the field strength is too small to be measured.*
5. *Measurements above show only up to 6 maximum emissions noted, or would be lesser, with " N/A " remark, if no specific emissions from the EUT are recorded (ie: margin>20dB from the applicable limit) and considered that's already beyond the background noise floor.*
6. *Margin (dB) = Remark result (dBuV/m) – Average limit (dBuV/m).*

**TX / IEEE 802.11g / CH High**

**Polarity: Vertical**

110.0 dBuV/m



**Polarity: Horizontal**

110.0 dBuV/m



**Operation Mode:** TX / IEEE 802.11g / CH High

**Test Date:** April 28, 2016

**Temperature:** 27°C

**Tested by:** Dennis Li

**Humidity:** 53% RH

**Polarity:** Ver. / Hor.

Frequency (MHz)	Reading (dBuV)	Correction Factor (dB/m)	Result (dBuV/m)	Limit (dBuV/m)	Margin (dB)	Remark	Ant. Pol. (H/V)
4924.000	35.89	5.37	41.26	74.00	-32.74	peak	V
4924.000	24.84	5.37	30.21	54.00	-23.79	AVG	V
7386.000	34.84	13.17	48.01	74.00	-25.99	peak	V
7386.000	23.17	13.17	36.34	54.00	-17.66	AVG	V
9848.000	31.44	17.60	49.04	74.00	-24.96	peak	V
N/A							
4924.000	37.47	5.37	42.84	74.00	-31.16	peak	H
4924.000	24.74	5.37	30.11	54.00	-23.89	AVG	H
7386.000	34.74	13.17	47.91	74.00	-26.09	peak	H
7386.000	22.45	13.17	35.62	54.00	-18.38	AVG	H
9848.000	33.04	17.60	50.64	74.00	-23.36	peak	H
N/A							

**Remark:**

1. Measuring frequencies from 1 GHz to the 10th harmonic of highest fundamental frequency.
2. Radiated emissions measured in frequency above 1000MHz were made with an instrument using peak/average detector mode.
3. Average test would be performed if the peak result were greater than the average limit or as required by the applicant.
4. Data of measurement within this frequency range shown " --- " in the table above means the reading of emissions are attenuated more than 20dB below the permissible limits or the field strength is too small to be measured.
5. Measurements above show only up to 6 maximum emissions noted, or would be lesser, with " N/A " remark, if no specific emissions from the EUT are recorded (ie: margin>20dB from the applicable limit) and considered that's already beyond the background noise floor.
6. Margin (dB) = Remark result (dBuV/m) – Average limit (dBuV/m).

**TX / IEEE 802.11n HT 20 MHz mode / CH Low**

**Polarity: Vertical**

110.0 dBuV/m

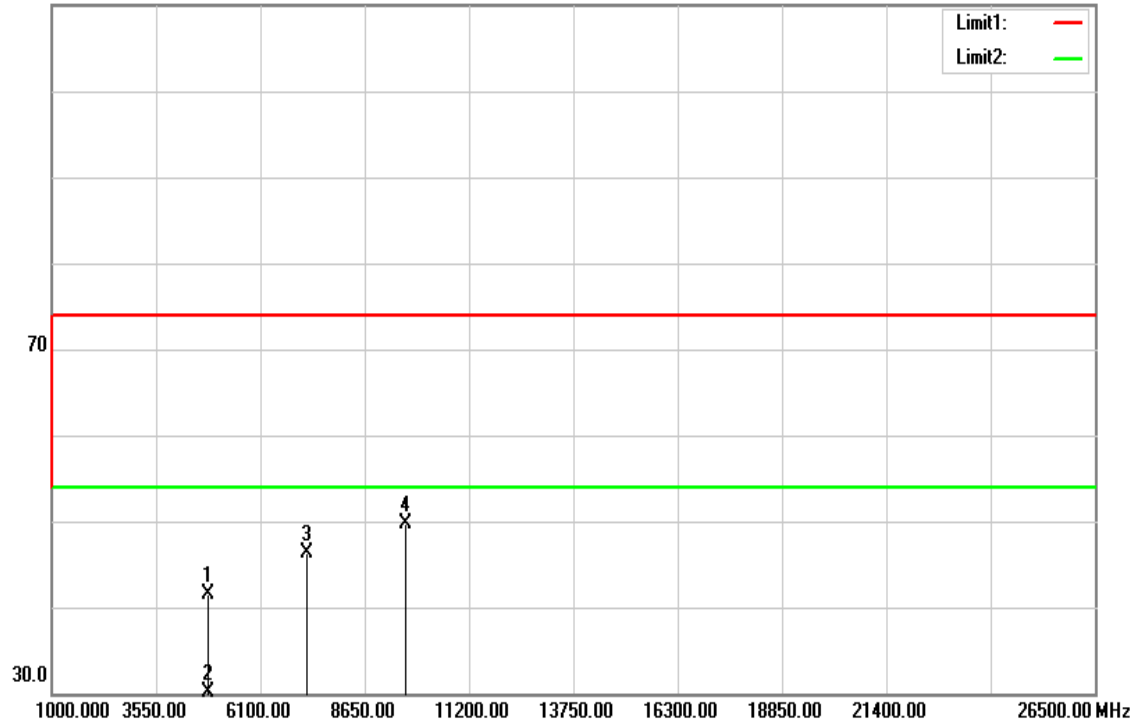

**Polarity: Horizontal**

110.0 dBuV/m

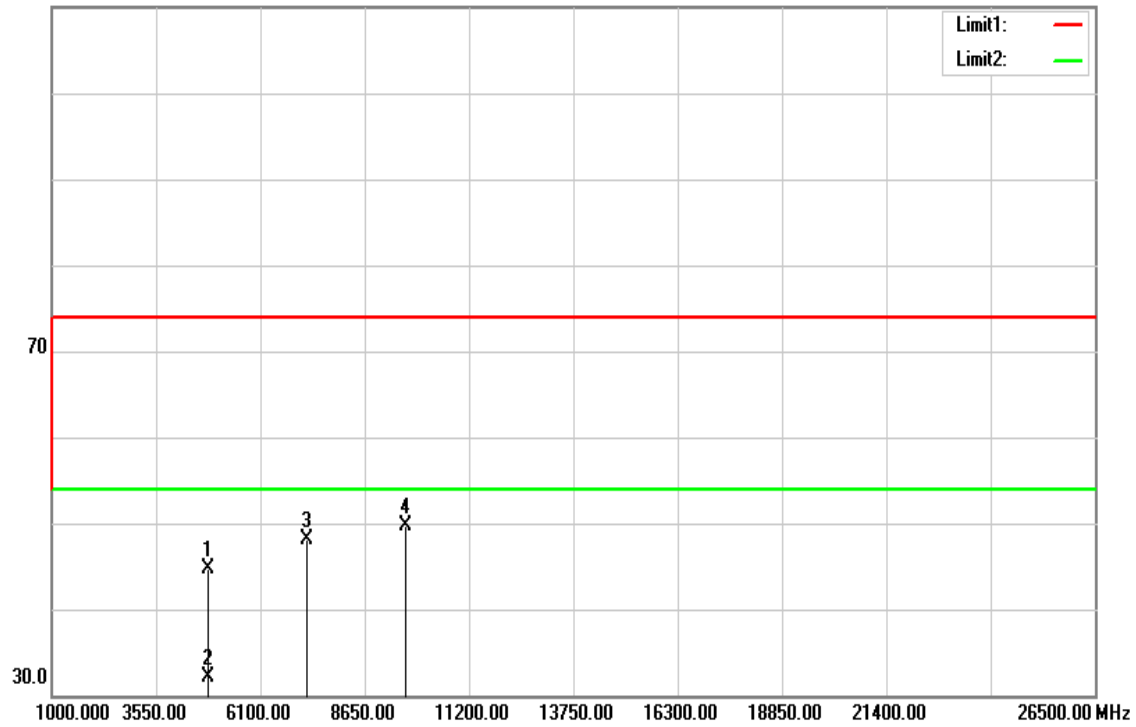

**Operation Mode:** TX / IEEE 802.11n HT 20 MHz mode / CH Low **Test Date:** April 28, 2016

**Temperature:** 27°C

**Tested by:** Dennis Li

**Humidity:** 53% RH

**Polarity:** Ver. / Hor.

Frequency (MHz)	Reading (dBuV)	Correction Factor (dB/m)	Result (dBuV/m)	Limit (dBuV/m)	Margin (dB)	Remark	Ant. Pol. (H/V)
4824.000	36.35	5.10	41.45	74.00	-32.55	peak	V
4824.000	25.01	5.10	30.11	54.00	-23.89	AVG	V
7236.000	33.51	12.71	46.22	74.00	-27.78	peak	V
9648.000	32.06	17.60	49.66	74.00	-24.34	peak	V
N/A							
4827.000	39.52	5.11	44.63	74.00	-29.37	peak	H
4827.000	27.08	5.11	32.19	54.00	-21.81	AVG	H
7236.000	35.33	12.71	48.04	74.00	-25.96	peak	H
9648.000	32.01	17.60	49.61	74.00	-24.39	peak	H
N/A							

**Remark:**

1. Measuring frequencies from 1 GHz to the 10th harmonic of highest fundamental frequency.
2. Radiated emissions measured in frequency above 1000MHz were made with an instrument using peak/average detector mode.
3. Average test would be performed if the peak result were greater than the average limit or as required by the applicant.
4. Data of measurement within this frequency range shown " --- " in the table above means the reading of emissions are attenuated more than 20dB below the permissible limits or the field strength is too small to be measured.
5. Measurements above show only up to 6 maximum emissions noted, or would be lesser, with " N/A " remark, if no specific emissions from the EUT are recorded (ie: margin>20dB from the applicable limit) and considered that's already beyond the background noise floor.
6. Margin (dB) = Remark result (dBuV/m) – Average limit (dBuV/m).

**TX / IEEE 802.11n HT 20 MHz mode / CH Mid**

**Polarity: Vertical**

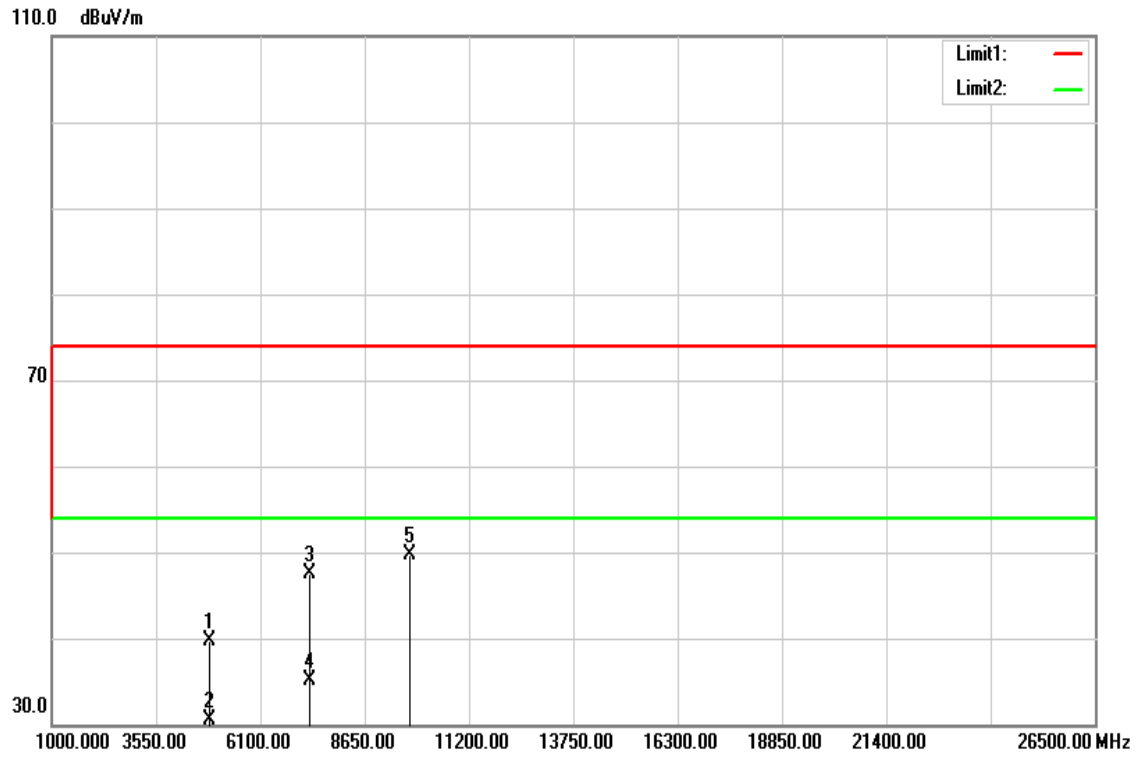

**Polarity: Horizontal**

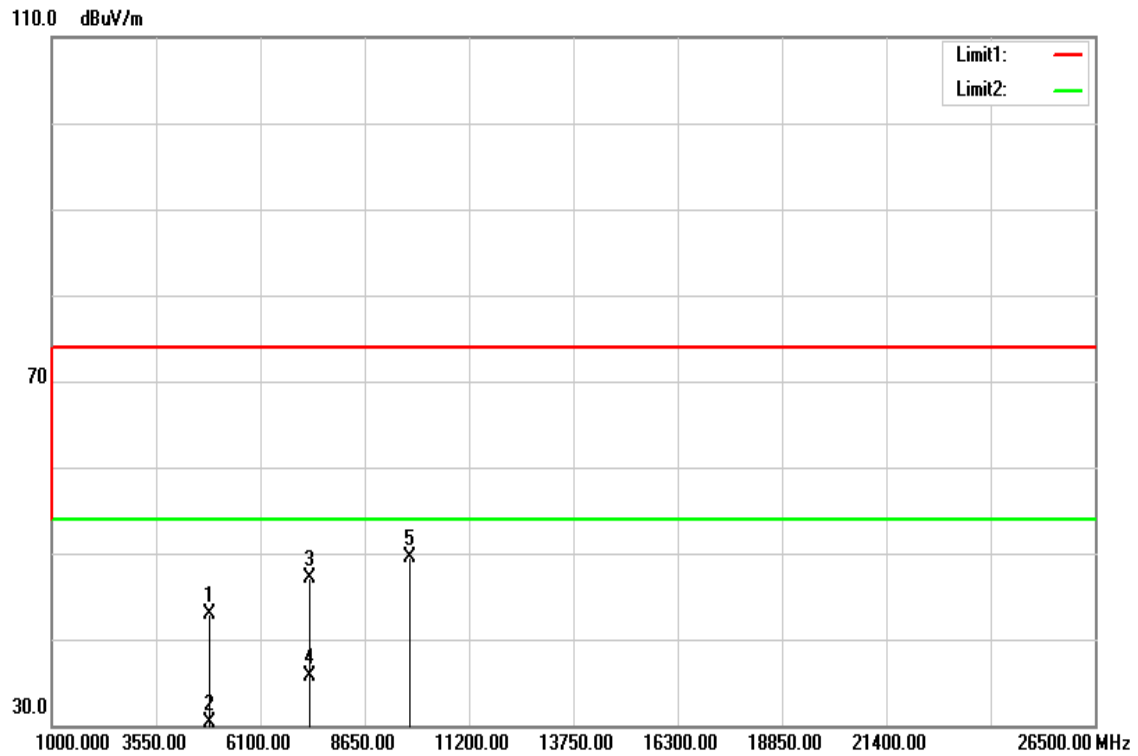

**Operation Mode:** TX / IEEE 802.11n HT 20 MHz mode / CH Mid **Test Date:** April 28, 2016

**Temperature:** 27°C

**Tested by:** Dennis Li

**Humidity:** 53% RH

**Polarity:** Ver. / Hor.

Frequency (MHz)	Reading (dBuV)	Correction Factor (dB/m)	Result (dBuV/m)	Limit (dBuV/m)	Margin (dB)	Remark	Ant. Pol. (H/V)
4874.000	34.44	5.23	39.67	74.00	-34.33	peak	V
4874.000	25.19	5.23	30.42	54.00	-23.58	AVG	V
7311.000	34.55	12.94	47.49	74.00	-26.51	peak	V
7311.000	22.18	12.94	35.12	54.00	-18.88	AVG	V
9748.000	32.17	17.60	49.77	74.00	-24.23	peak	V
N/A							
4874.000	37.66	5.23	42.89	74.00	-31.11	peak	H
4874.000	25.02	5.23	30.25	54.00	-23.75	AVG	H
7311.000	34.22	12.94	47.16	74.00	-26.84	peak	H
7311.000	22.70	12.94	35.64	54.00	-18.36	AVG	H
9748.000	31.83	17.60	49.43	74.00	-24.57	peak	H
N/A							

**Remark:**

1. Measuring frequencies from 1 GHz to the 10th harmonic of highest fundamental frequency.
2. Radiated emissions measured in frequency above 1000MHz were made with an instrument using peak/average detector mode.
3. Average test would be performed if the peak result were greater than the average limit or as required by the applicant.
4. Data of measurement within this frequency range shown " --- " in the table above means the reading of emissions are attenuated more than 20dB below the permissible limits or the field strength is too small to be measured.
5. Measurements above show only up to 6 maximum emissions noted, or would be lesser, with " N/A " remark, if no specific emissions from the EUT are recorded (ie: margin>20dB from the applicable limit) and considered that's already beyond the background noise floor.
6. Margin (dB) = Remark result (dBuV/m) – Average limit (dBuV/m).

**TX / IEEE 802.11n HT 20 MHz mode / CH High**

**Polarity: Vertical**

110.0 dBuV/m



**Polarity: Horizontal**

110.0 dBuV/m

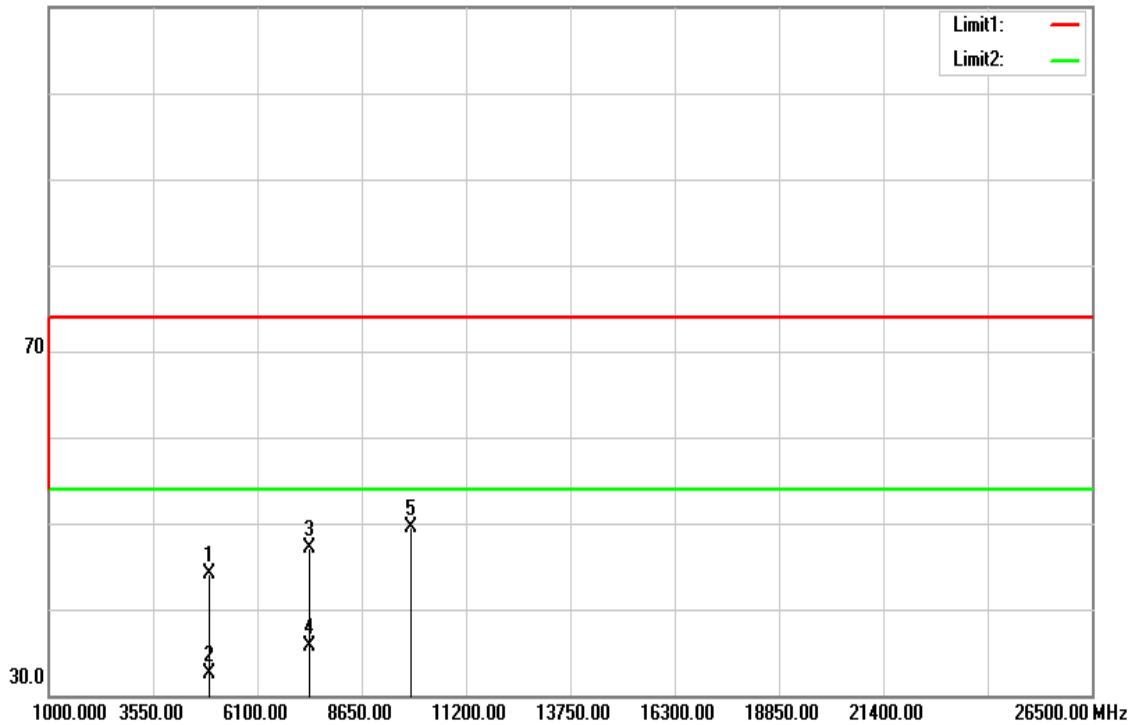



**Operation Mode:** TX / IEEE 802.11n HT 20 MHz mode / CH High **Test Date:** April 28, 2016

**Temperature:** 27°C

**Tested by:** Dennis Li

**Humidity:** 53% RH

**Polarity:** Ver. / Hor.

Frequency (MHz)	Reading (dBuV)	Correction Factor (dB/m)	Result (dBuV/m)	Limit (dBuV/m)	Margin (dB)	Remark	Ant. Pol. (H/V)
4924.000	36.94	5.37	42.31	74.00	-31.69	peak	V
4924.000	24.78	5.37	30.15	54.00	-23.85	AVG	V
7386.000	34.96	13.17	48.13	74.00	-25.87	peak	V
7386.000	22.50	13.17	35.67	54.00	-18.33	AVG	V
9848.000	33.10	17.60	50.70	74.00	-23.30	peak	V
N/A							
4924.000	38.69	5.37	44.06	74.00	-29.94	peak	H
4924.000	27.14	5.37	32.51	54.00	-21.49	AVG	H
7386.000	34.02	13.17	47.19	74.00	-26.81	peak	H
7386.000	22.47	13.17	35.64	54.00	-18.36	AVG	H
9848.000	31.92	17.60	49.52	74.00	-24.48	peak	H
N/A							

**Remark:**

1. *Measuring frequencies from 1 GHz to the 10th harmonic of highest fundamental frequency.*
2. *Radiated emissions measured in frequency above 1000MHz were made with an instrument using peak/average detector mode.*
3. *Average test would be performed if the peak result were greater than the average limit or as required by the applicant.*
4. *Data of measurement within this frequency range shown " --- " in the table above means the reading of emissions are attenuated more than 20dB below the permissible limits or the field strength is too small to be measured.*
5. *Measurements above show only up to 6 maximum emissions noted, or would be lesser, with " N/A " remark, if no specific emissions from the EUT are recorded (ie: margin>20dB from the applicable limit) and considered that's already beyond the background noise floor.*
6. *Margin (dB) = Remark result (dBuV/m) – Average limit (dBuV/m).*

**TX / IEEE 802.11n HT 40 MHz mode / CH Low**

**Polarity: Vertical**

110.0 dBuV/m

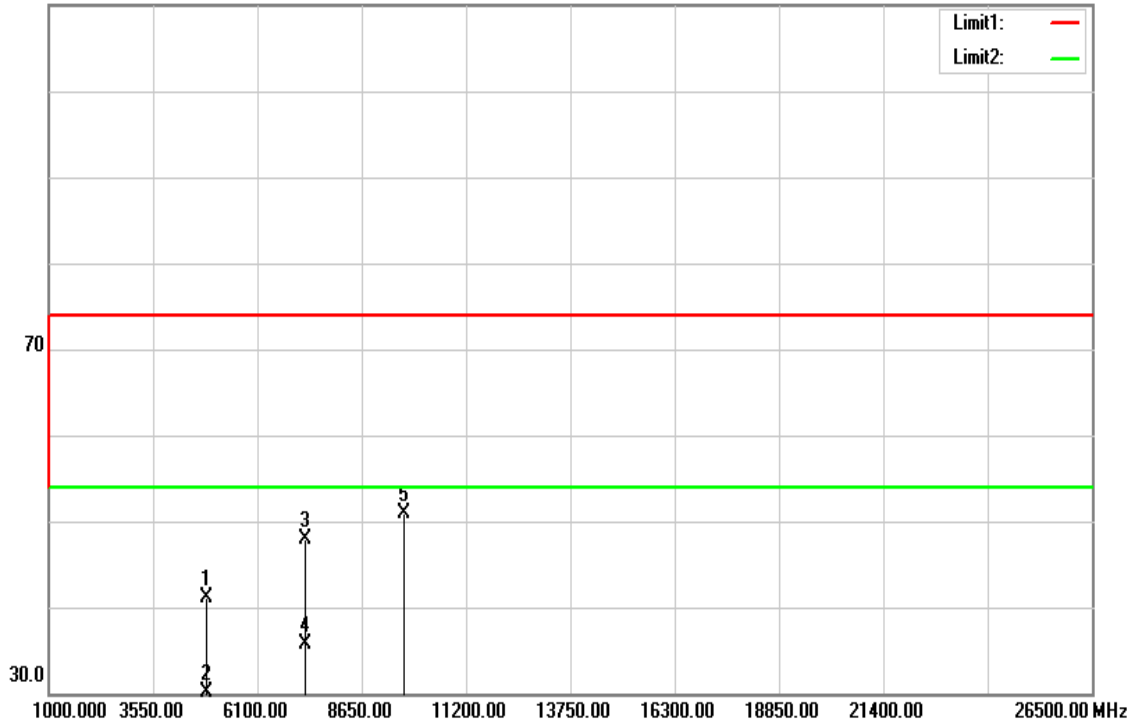

**Polarity: Horizontal**

110.0 dBuV/m

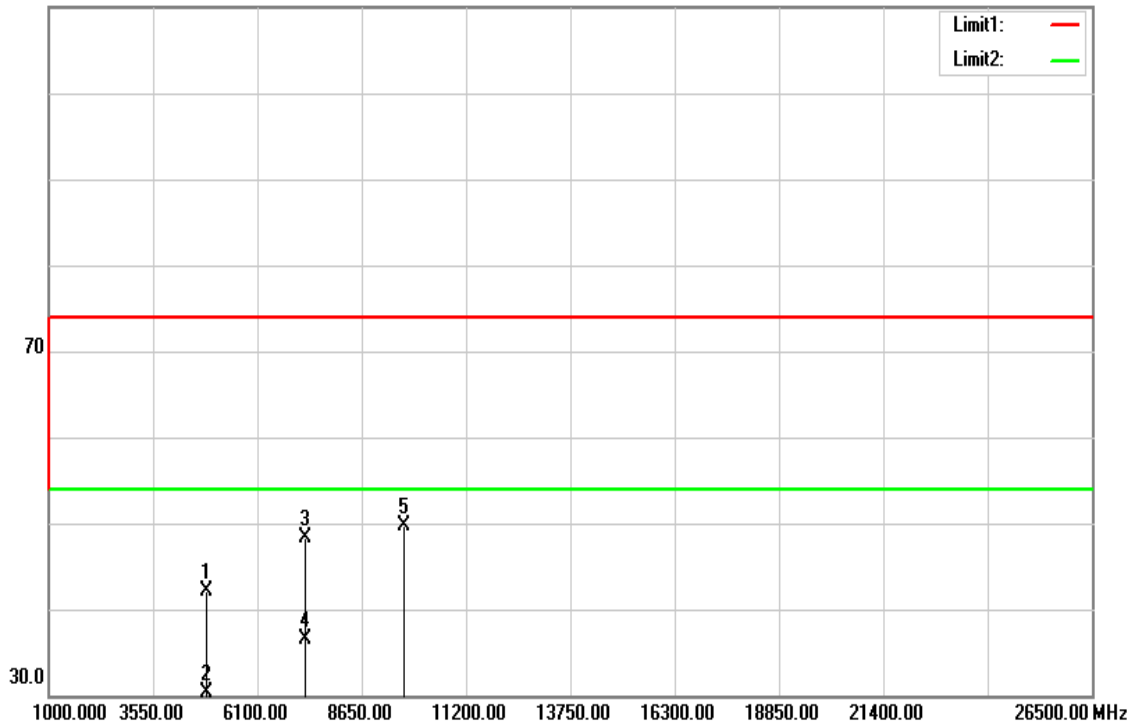

**Operation Mode:** TX / IEEE 802.11n HT 40 MHz mode / CH Low **Test Date:** April 28, 2016

**Temperature:** 27°C

**Tested by:** Dennis Li

**Humidity:** 53% RH

**Polarity:** Ver. / Hor.

Frequency (MHz)	Reading (dBuV)	Correction Factor (dB/m)	Result (dBuV/m)	Limit (dBuV/m)	Margin (dB)	Remark	Ant. Pol. (H/V)
4844.000	35.91	5.15	41.06	74.00	-32.94	peak	V
4844.000	25.00	5.15	30.15	54.00	-23.85	AVG	V
7266.000	35.07	12.80	47.87	74.00	-26.13	peak	V
7266.000	22.84	12.80	35.64	54.00	-18.36	AVG	V
9688.000	33.24	17.60	50.84	74.00	-23.16	peak	V
N/A							
4844.000	37.03	5.15	42.18	74.00	-31.82	peak	H
4844.000	25.11	5.15	30.26	54.00	-23.74	AVG	H
7266.000	35.41	12.80	48.21	74.00	-25.79	peak	H
7266.000	23.74	12.80	36.54	54.00	-17.46	AVG	H
9688.000	32.09	17.60	49.69	74.00	-24.31	peak	H
N/A							

**Remark:**

1. Measuring frequencies from 1 GHz to the 10th harmonic of highest fundamental frequency.
2. Radiated emissions measured in frequency above 1000MHz were made with an instrument using peak/average detector mode.
3. Average test would be performed if the peak result were greater than the average limit or as required by the applicant.
4. Data of measurement within this frequency range shown " --- " in the table above means the reading of emissions are attenuated more than 20dB below the permissible limits or the field strength is too small to be measured.
5. Measurements above show only up to 6 maximum emissions noted, or would be lesser, with " N/A " remark, if no specific emissions from the EUT are recorded (ie: margin>20dB from the applicable limit) and considered that's already beyond the background noise floor.
6. Margin (dB) = Remark result (dBuV/m) – Average limit (dBuV/m).

**TX / IEEE 802.11n HT 40 MHz mode / CH Mid**

**Polarity: Vertical**

110.0 dBuV/m

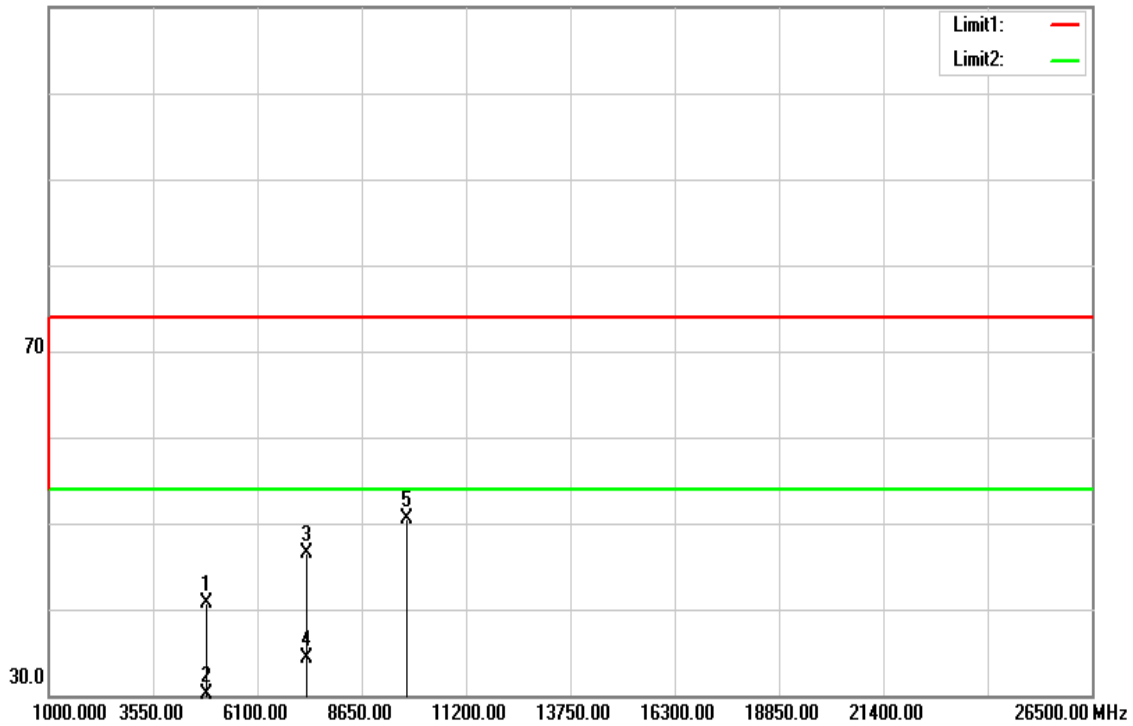

**Polarity: Horizontal**

110.0 dBuV/m

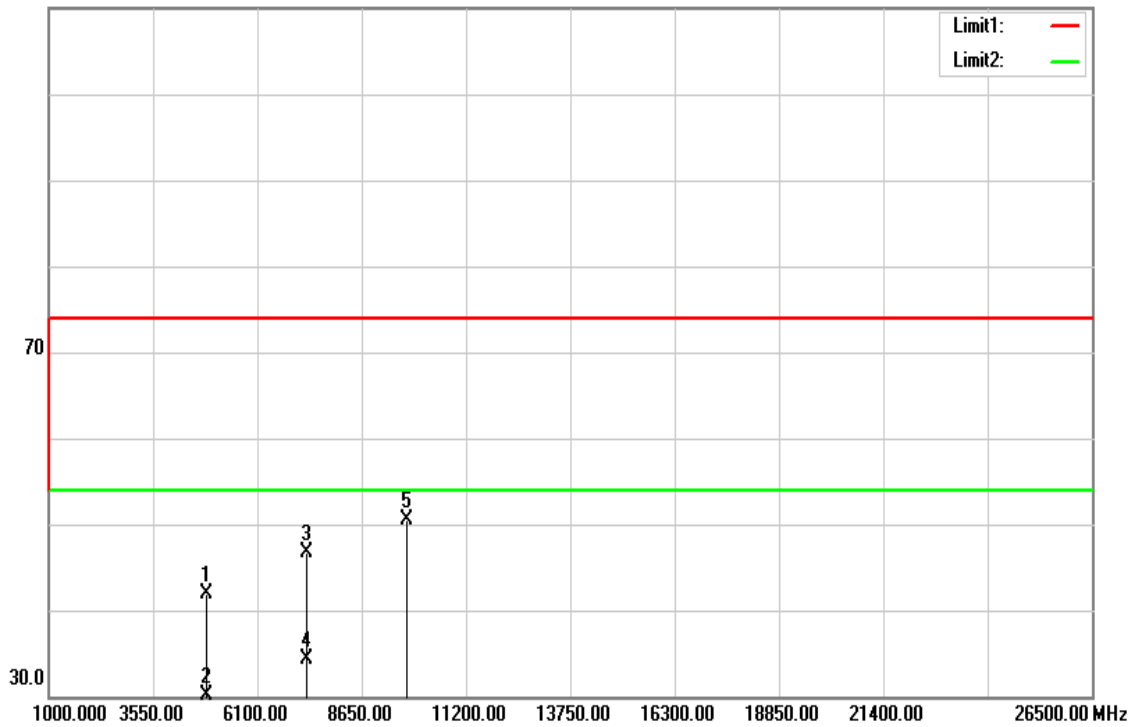

**Operation Mode:** TX / IEEE 802.11n HT 40 MHz mode / CH Mid **Test Date:** April 28, 2016

**Temperature:** 27°C

**Tested by:** Dennis Li

**Humidity:** 53% RH

**Polarity:** Ver. / Hor.

Frequency (MHz)	Reading (dBuV)	Correction Factor (dB/m)	Result (dBuV/m)	Limit (dBuV/m)	Margin (dB)	Remark	Ant. Pol. (H/V)
4874.000	35.57	5.23	40.80	74.00	-33.20	peak	V
4874.000	24.92	5.23	30.15	54.00	-23.85	AVG	V
7311.000	33.58	12.94	46.52	74.00	-27.48	peak	V
7311.000	21.40	12.94	34.34	54.00	-19.66	AVG	V
9748.000	32.81	17.60	50.41	74.00	-23.59	peak	V
N/A							
4874.000	36.66	5.23	41.89	74.00	-32.11	peak	H
4874.000	24.89	5.23	30.12	54.00	-23.88	AVG	H
7311.000	33.79	12.94	46.73	74.00	-27.27	peak	H
7311.000	21.29	12.94	34.23	54.00	-19.77	AVG	H
9748.000	33.00	17.60	50.60	74.00	-23.40	peak	H
N/A							

**Remark:**

1. Measuring frequencies from 1 GHz to the 10th harmonic of highest fundamental frequency.
2. Radiated emissions measured in frequency above 1000MHz were made with an instrument using peak/average detector mode.
3. Average test would be performed if the peak result were greater than the average limit or as required by the applicant.
4. Data of measurement within this frequency range shown " --- " in the table above means the reading of emissions are attenuated more than 20dB below the permissible limits or the field strength is too small to be measured.
5. Measurements above show only up to 6 maximum emissions noted, or would be lesser, with " N/A " remark, if no specific emissions from the EUT are recorded (ie: margin>20dB from the applicable limit) and considered that's already beyond the background noise floor.
6. Margin (dB) = Remark result (dBuV/m) – Average limit (dBuV/m).

**TX / IEEE 802.11n HT 40 MHz mode / CH High**

**Polarity: Vertical**

110.0 dBuV/m



**Polarity: Horizontal**

110.0 dBuV/m



**Operation Mode:** TX / IEEE 802.11n HT 40 MHz mode / CH High **Test Date:** April 28, 2016

**Temperature:** 27°C

**Tested by:** Dennis Li

**Humidity:** 53% RH

**Polarity:** Ver. / Hor.

Frequency (MHz)	Reading (dBuV)	Correction Factor (dB/m)	Result (dBuV/m)	Limit (dBuV/m)	Margin (dB)	Remark	Ant. Pol. (H/V)
4904.000	36.58	5.31	41.89	74.00	-32.11	peak	V
4904.000	24.81	5.31	30.12	54.00	-23.88	AVG	V
7356.000	33.65	13.08	46.73	74.00	-27.27	peak	V
7356.000	21.15	13.08	34.23	54.00	-19.77	AVG	V
9808.000	33.00	17.60	50.60	74.00	-23.40	peak	V
N/A							
4904.000	36.58	5.31	41.89	74.00	-32.11	peak	H
4904.000	24.81	5.31	30.12	54.00	-23.88	AVG	H
7356.000	33.65	13.08	46.73	74.00	-27.27	peak	H
7356.000	21.15	13.08	34.23	54.00	-19.77	AVG	H
9808.000	33.00	17.60	50.60	74.00	-23.40	peak	H
N/A							

**Remark:**

1. Measuring frequencies from 1 GHz to the 10th harmonic of highest fundamental frequency.
2. Radiated emissions measured in frequency above 1000MHz were made with an instrument using peak/average detector mode.
3. Average test would be performed if the peak result were greater than the average limit or as required by the applicant.
4. Data of measurement within this frequency range shown " --- " in the table above means the reading of emissions are attenuated more than 20dB below the permissible limits or the field strength is too small to be measured.
5. Measurements above show only up to 6 maximum emissions noted, or would be lesser, with " N/A " remark, if no specific emissions from the EUT are recorded (ie: margin>20dB from the applicable limit) and considered that's already beyond the background noise floor.
6. Margin (dB) = Remark result (dBuV/m) – Average limit (dBuV/m).

## 7.8 POWERLINE CONDUCTED EMISSIONS

### LIMIT

According to §15.207(a) & RSS-Gen §7.2.4, except as shown in paragraphs (b) and (c) of this section, for an intentional radiator that is designed to be connected to the public utility (AC) power line, the radio frequency voltage that is conducted back onto the AC power line on any frequency or frequencies within the band 150 kHz to 30 MHz shall not exceed the limits in the following table, as measured using a 50  $\mu$ H/50 ohms line impedance stabilization network (LISN). Compliance with the provisions of this paragraph shall be based on the measurement of the radio frequency voltage between each power line and ground at the power terminal. The lower limit applies at the boundary between the frequency ranges.

Frequency Range (MHz)	Limits (dB $\mu$ V)	
	Quasi-peak	Average
0.15 to 0.50	66 to 56*	56 to 46*
0.50 to 5	56	46
5 to 30	60	50

\* Decreases with the logarithm of the frequency.

### Test Configuration

See test photographs attached in Appendix II for the actual connections between EUT and support equipment.

### TEST PROCEDURE

1. The EUT was placed on a table, which is 0.8m above ground plane.
2. Maximum procedure was performed on the six highest emissions to ensure EUT compliance.
3. Repeat above procedures until all frequency measured were complete.





**Test Plots**

**Conducted emissions (Line 1)**

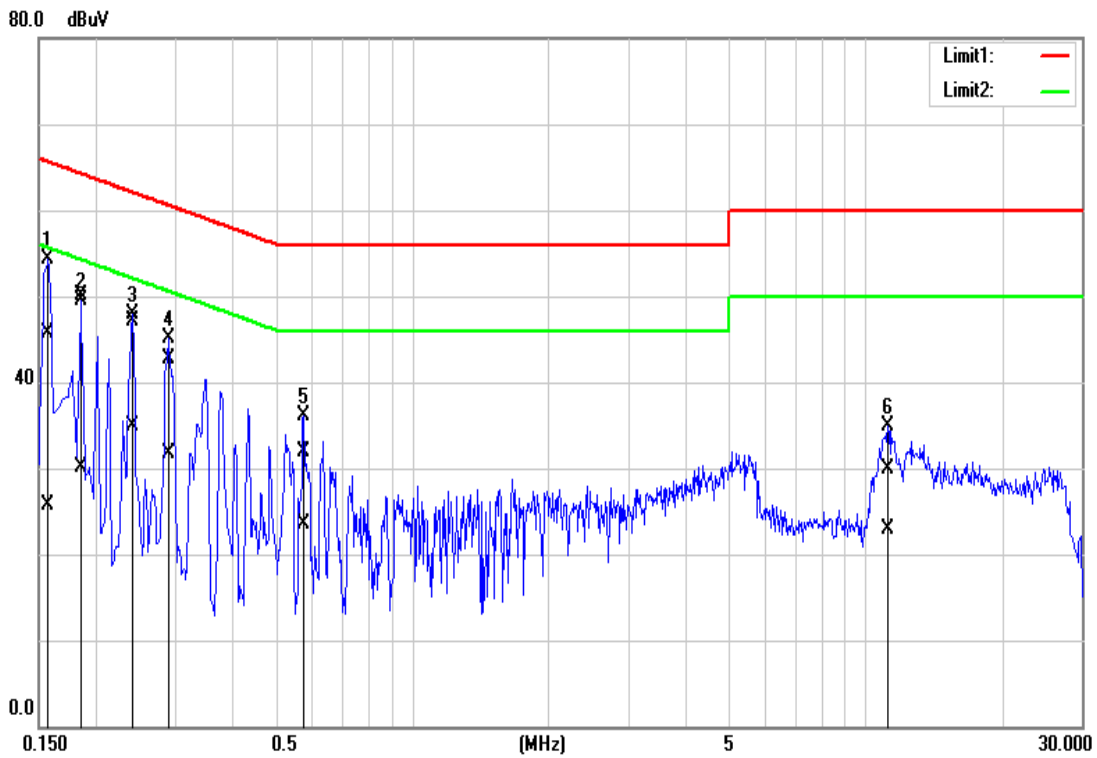

**Conducted emissions (Line 2)**

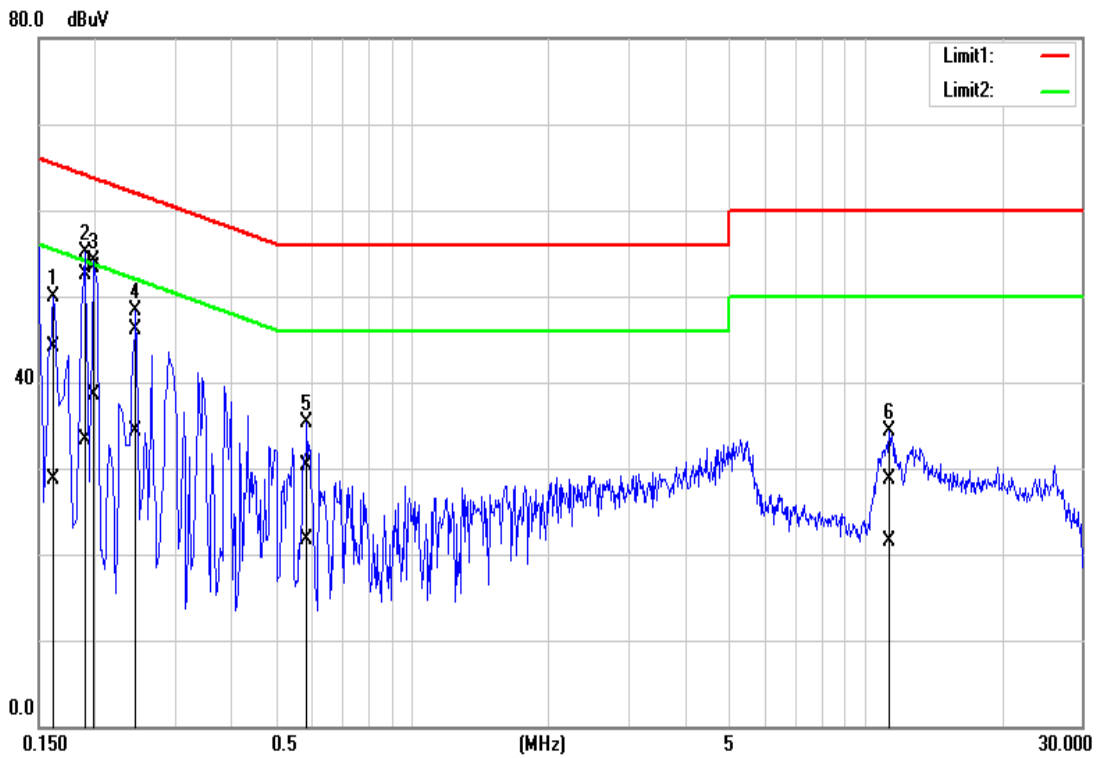

## APPENDIX II PHOTOGRAPHS OF TEST SETUP

### Conducted Emissions Setup Photos

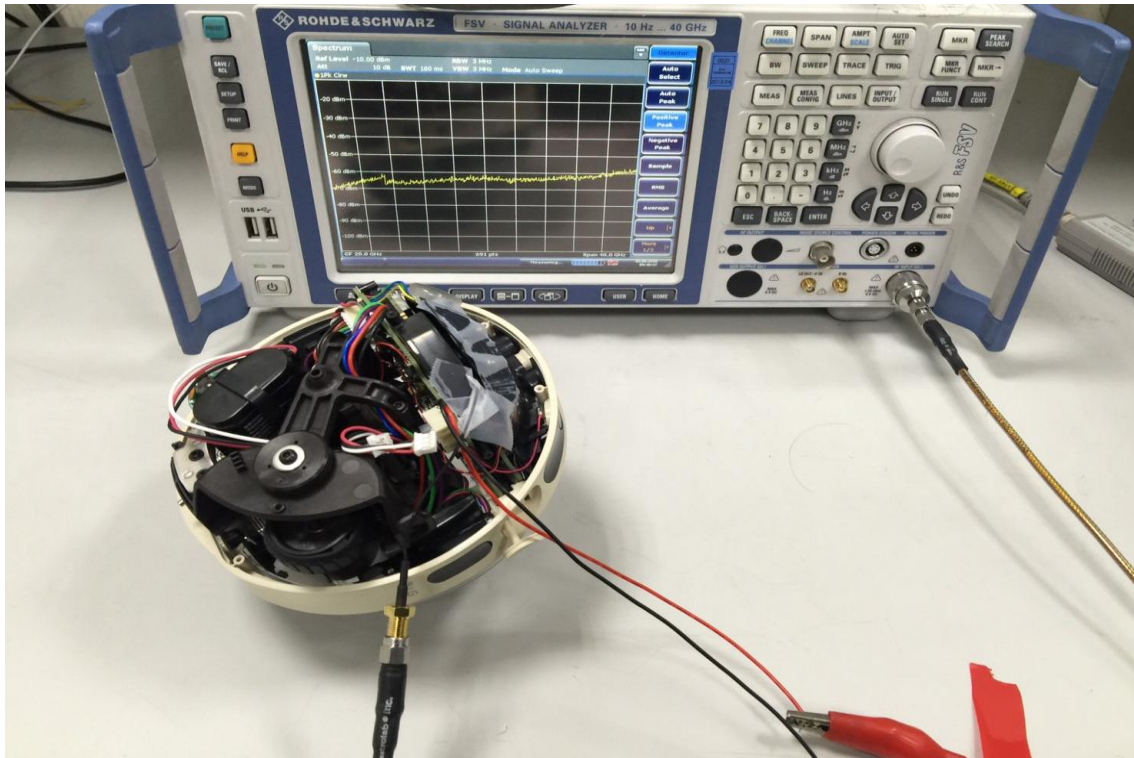

## Radiated Emissions Setup Photos Below 1 GHz

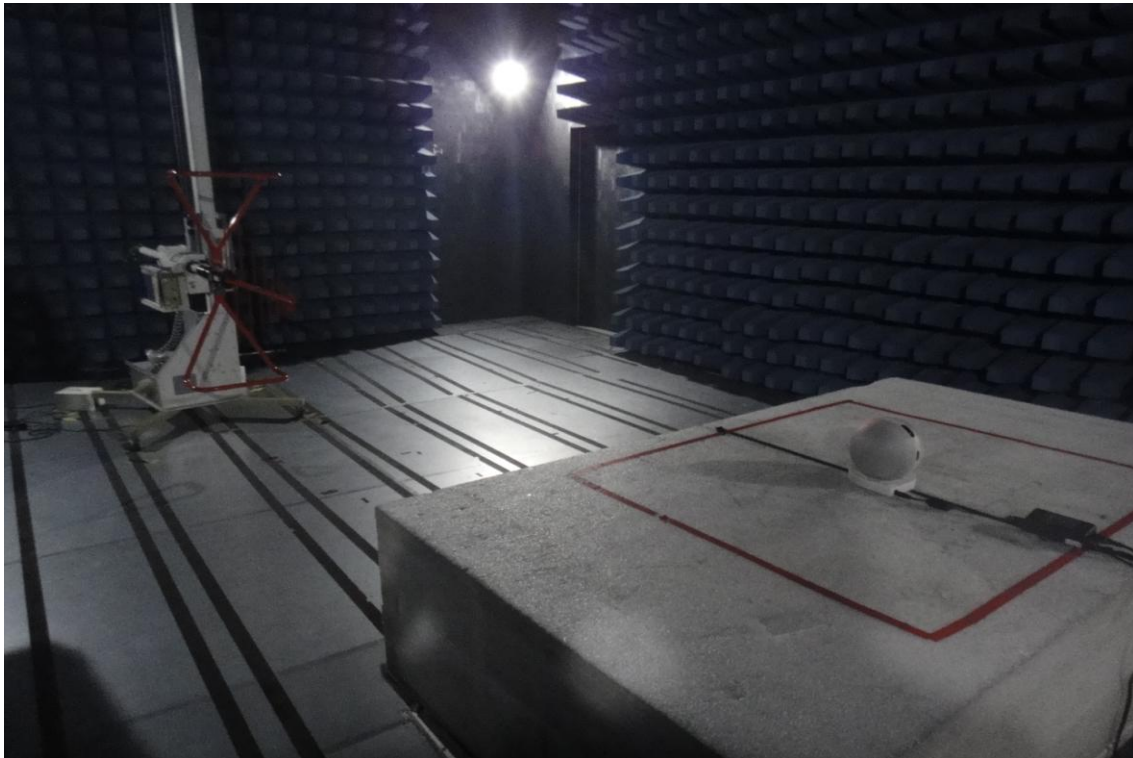
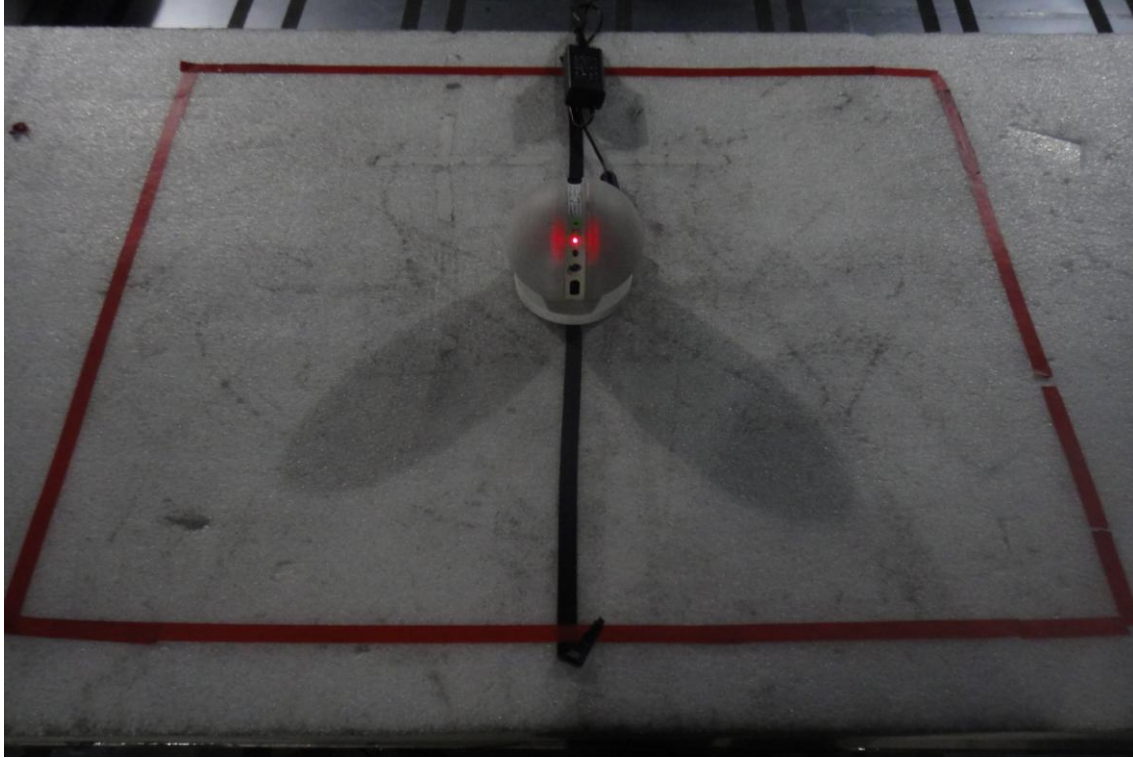

## Above 1 GHz

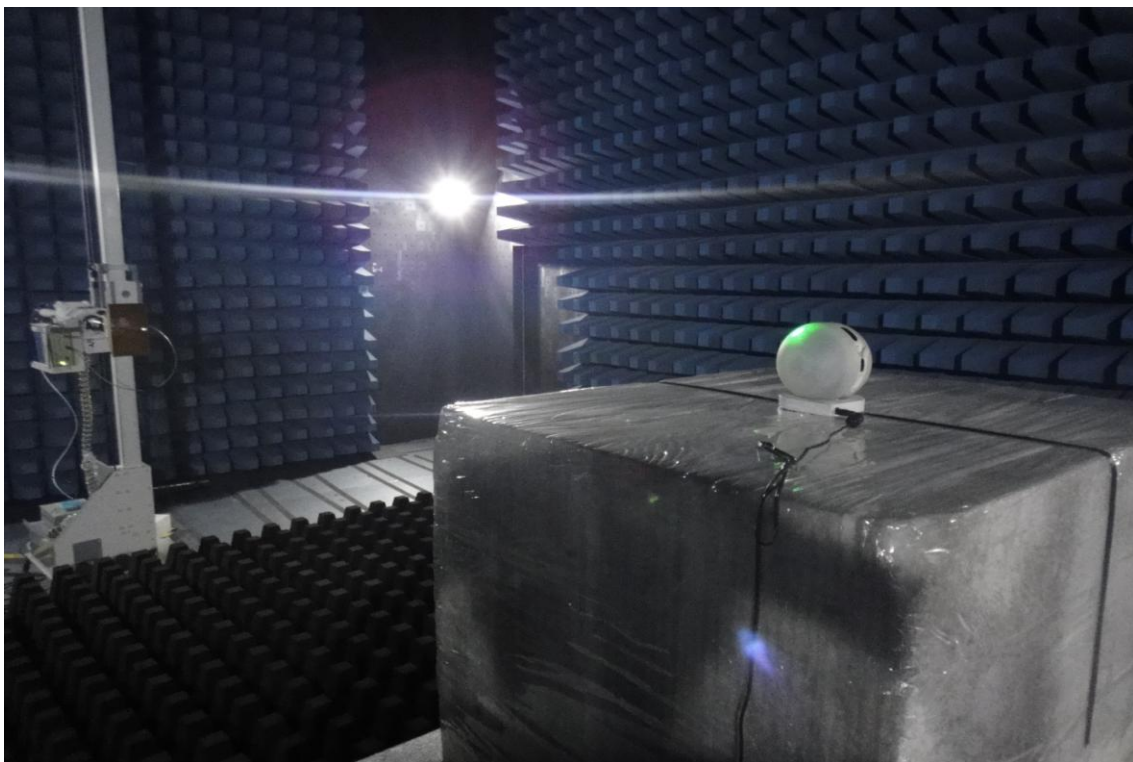
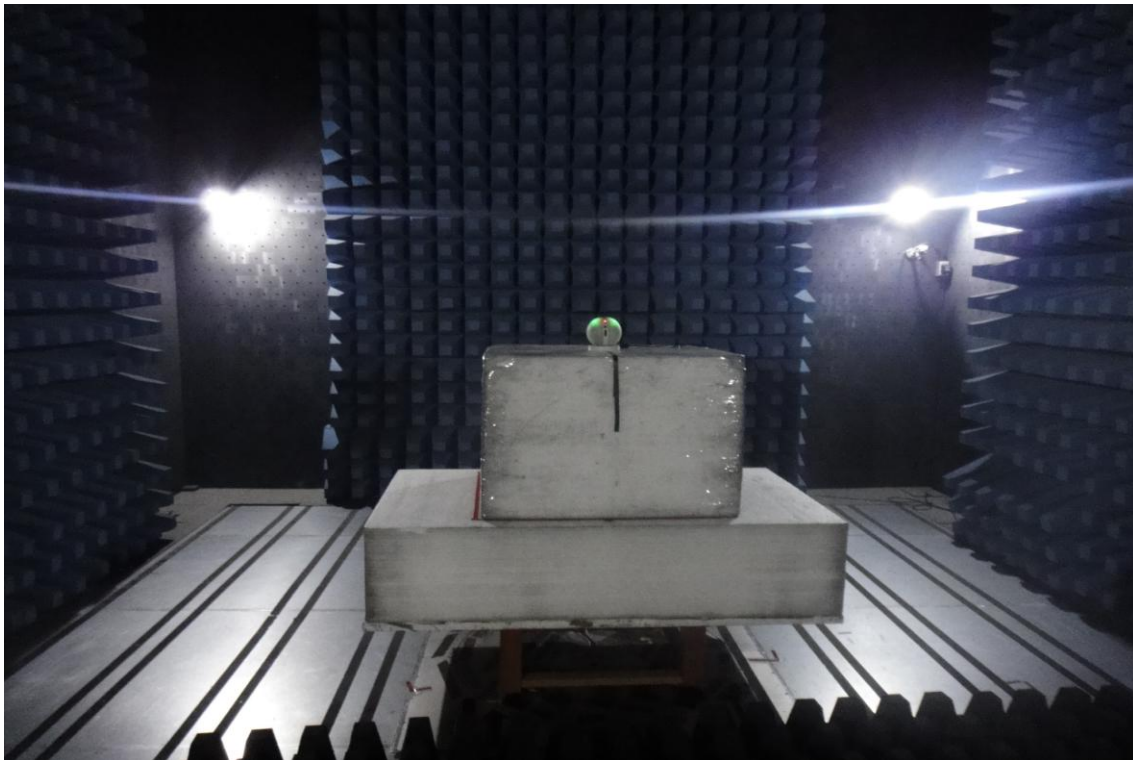

## Powerline Conducted Emissions Setup Photos

