

TEST REPORT



DT&C Co., Ltd.

42, Yurim-ro, 154Beon-gil, Cheoin-gu, Yongin-si, Gyeonggi-do, Korea, 17042
Tel : 031-321-2664, Fax : 031-321-1664

1. Report No : DRRFCC1709-0109(2)
2. Customer
 - Name : LG Electronics MobileComm USA, Inc.
 - Address : 1000 Sylvan Ave., Englewood Cliffs, New Jersey, United States, 07632
3. Use of Report : FCC Original Grant
4. Product Name / Model Name : Mobile Phone / QVR
FCC ID : ZNFQVR
5. Test Method Used : IEEE 1528-2013 , FCC SAR KDB Publications (Details in test report)
Test Specification : CFR §2.1093
6. Date of Test : 2017.09.05 ~ 2017.09.22
7. Testing Environment : Refer to attached test report.
8. Test Result : Refer to attached test report.

Affirmation	Tested by	 (Signature)	Technical Manager	 (Signature)
	Name : HoSik Sim		Name : HakMin Kim	

The test results presented in this test report are limited only to the sample supplied by applicant and the use of this test report is inhibited other than its purpose. This test report shall not be reproduced except in full, without the written approval of DT&C Co., Ltd.

2017 . 10 . 05 .

DT&C Co., Ltd.

If this report is required to confirmation of authenticity, please contact to report@dtnc.net

Test Report Version

Test Report No.	Date	Description
DRRFCC1709-0109	Sep. 22, 2017	Initial issue
DRRFCC1709-0109(1)	Oct. 02, 2017	Modify Bluetooth Tune-up
DRRFCC1709-0109(2)	Oct. 05, 2017	Modify GPRS/EDGE Class

Table of Contents

1. DESCRIPTION OF DEVICE	5
1.1 Guidance Applied.....	7
1.2 Device Overview.....	7
1.3 Nominal and Maximum Output Power Specifications	7
1.4 DUT Antenna Locations.....	10
1.5 Near Field Communications (NFC) Antenna.....	10
1.6 SAR Test Exclusions Applied	10
1.7 Power Reduction for SAR.....	10
1.8 Device Serial Numbers.....	11
1.9 LTE Information	11
2. INTROCUCTION	12
3. DESCRIPTION OF TEST EQUIPMENT	13
3.1 SAR MEASUREMENT SETUP.....	13
3.2 ES3DV3/EX3DV4Probe Specification	14
3.3 Probe Calibration Process	15
3.3.1 E-Probe Calibration	15
3.4 Data Extrapolation	16
3.5 SAM Twin PHANTOM.....	17
3.6 Device Holder for Transmitters	17
3.7 Brain & Muscle Simulation Mixture Characterization	18
3.8 SAR TEST EQUIPMENT	20
4. TEST SYSTEM SPECIFICATIONS	21
5. SAR MEASUREMENT PROCEDURE	22
5.1 Measurement Procedure	22
6. DEFINITION OF REFERENCE POINTS	24
6.1 Ear Reference Point	24
6.2 Handset Reference Points.....	24
7. TEST CONFIGURATION POSITIONS FOR HANDSETS	25
7.1 Device Holder	25
7.2 Positioning for Cheek/Touch	25
7.3 Positioning for Ear / 15 ° Tilt	25
7.4 Body-Worn Accessory Configurations	26
7.5 Extremity Exposure Configurations.....	26
7.6 Wireless Router Configurations	27
8. RF EXPOSURE LIMITS	28
9. FCC MEASUREMENT PROCEDURES	29
9.1 Measured and Reported SAR.....	29
9.2 Procedures Used to Establish RF Signal for SAR	29
9.3 SAR Measurement Conditions for WCDMA (UMTS)	29
9.3.1 Output Power Verification	29
9.3.2 Head SAR Measurements for Handsets.....	29
9.3.3 Body SAR Measurements	30
9.3.4 Release 5 HSDPA Data Devices	30
9.3.5 Release 6 HSUPA Data Devices	30
9.4 SAR Measurement Conditions for LTE	31
9.4.1 Spectrum Plots for RB Configurations	31
9.4.2 MPR.....	31
9.4.3 A-MPR	31
9.4.4 Required RB Size and RB Offsets for SAR Testing	31
9.5 SAR Testing with 802.11 Transmitters	32
9.5.1 General Device Setup.....	32
9.5.2 U-NII and U-NII-2A	32

9.5.3 U-NII-2C and U-NII-3	32
9.5.4 Initial Test Position Procedure.....	33
9.5.5 2.4 GHz SAR Test Requirements	33
9.5.6 OFDM Transmission Mode and SAR Test Channel Selection	33
9.5.7 Initial Test Configuration Procedure	33
9.5.8 Subsequent Test Configuration Procedures	34
9.5.9 MIMO SAR Considerations.....	34
10. RF CONDUCTED POWERS	35
10.1 GSM Conducted Powers	35
10.2 WCDMA Conducted Powers.....	36
10.3 LTE Conducted Powers	37
10.4 WLAN Conducted Powers	45
10.5 Bluetooth Conducted Powers	55
11. SYSTEM VERIFICATION	57
11.1 Tissue Verification	57
11.2 Test System Verification	59
12. SAR TEST RESULTS	61
12.1 Head SAR Results.....	61
12.2 Standalone Body-Worn SAR Worn SAR Results.....	68
12.3 Standalone Hotspot SAR Results.....	73
12.4 Standalone Phablet SAR Results	79
12.5 SAR Test Notes	81
13. FCC MULTI-TX AND ANTENNA SAR CONSIDERATIONS	84
13.1 Introduction.....	84
13.2 Simultaneous Transmission Procedures.....	84
13.3 Simultaneous Transmission Capabilities	84
13.4 Head SAR Simultaneous Transmission Analysis	86
13.5 Body-Worn Simultaneous Transmission Analysis	115
13.6 Hotspot SAR Simultaneous Transmission Analysis	142
13.7 Phablet SAR Simultaneous Transmission Analysis	162
13.8 Simultaneous Transmission Conclusion	162
14. SAR MEASUREMENT VARIABILITY	163
14.1 Measurement Variability	163
15. IEEE Std 1528 –MEASUREMENT UNCERTAINTIES	165
16. CONCLUSION	185
17. REFERENCES	186
Attachment 1. – Probe Calibration Data	188
Attachment 2. – Dipole Calibration Data.....	237
Attachment 3. – SAR SYSTEM VALIDATION	294

Equipment Class	Band	Reported SAR			
		1g SAR (W/kg)			10g SAR (W/kg)
		Head	Body-Worn	Hotspot	Phablet
PCE	GSM 850	0.20	0.58	-	-
PCE	GPRS 850	0.25	0.75	0.75	-
PCE	GSM 1900	0.18	0.72	-	-
PCE	GPRS 1900	0.23	0.99	0.99	-
PCE	WCDMA 850	0.25	0.76	0.76	-
PCE	WCDMA 1700	0.17	0.50	0.51	-
PCE	WCDMA 1900	0.21	0.96	0.96	-
PCE	LTE Band 17	< 0.1	0.46	0.46	-
PCE	LTE Band 13	< 0.1	0.27	0.27	-
PCE	LTE Band 5	0.22	0.73	0.73	-
DTS	2.4 GHz W-LAN	0.90	0.18	0.19	-
U-NII-1	5.2 GHz W-LAN	-	-	0.59	-
U-NII-2A	5.3 GHz W-LAN	0.95	0.57	-	2.22
U-NII-2C	5.6 GHz W-LAN	0.61	0.50	-	2.13
U-NII-3	5.8 GHz W-LAN	0.56	0.64	0.64	-
DSS	Bluetooth	0.23	< 0.1	< 0.1	N/A
Simultaneous SAR per KDB 690783 D01v01r03		1.28	1.54	1.54	-
FCC Equipment Class	Licensed Portable Transmitter Held to Ear (PCE) Part 15 Spread Spectrum Transmitter(DSS) Digital Transmission System(DTS) Unlicensed National Information Infrastructure (UNII)				
Date(s) of Tests	2017-09-05 ~ 2017-09-22				
Antenna Type	Internal Type Antenna				
Functions	<ul style="list-style-type: none"> ● GSM/GPRS (GPRS Class: 12) / EDGE (EDGE Class: 12) supported. * DTM not supported. ● BT(2.4GHz) / W-LAN(2.4GHz 802.11b/g/ n-HT20/ac-VHT20) supported. W-LAN(5GHz 802.11a/n-HT20/n-HT40/ac-VHT20/ac-VHT40/ac-VHT80) supported. * No simultaneous transmission between BT & 2.4GHz WLAN ● Simultaneous transmission between GSM, WCDMA voice & WLAN / GPRS, WCDMA & WLAN / LTE & WLAN. ● VoIP is supported. ● W-LAN 2.4GHz is supported Hotspot. ● W-LAN 5 GHz is supported Hotspot in UNII B1, B3. 				

1.1 Guidance Applied

- IEEE 1528-2013
- FCC KDB Publication 941225 D01v03r01 (3G SAR Procedures)
- FCC KDB Publication 941225 D05v02r05 (SAR for LTE Devices)
- FCC KDB Publication 941225 D05Av01r02 (LTE Rel.10 KDB Inquiry Sheet)
- FCC KDB Publication 941225 D06v02r01 (Hotspot Mode)
- FCC KDB Publication 248227 D01v02r02 (802.11 Wi-Fi SAR)
- FCC KDB Publication 447498 D01v06 (General RF Exposure Guidance)
- FCC KDB Publication 648474 D04v01r03 (Handset SAR)
- FCC KDB Publication 690783 D01v01r03 (SAR Listings on Grants)
- FCC KDB Publication 865664 D01v01r04 (SAR Measurement 100 MHz to 6 GHz)
- FCC KDB Publication 865664 D02v01r02 (RF Exposure Reporting)
- October 2013 TCB Workshop Notes (GPRS testing criteria)
- April 2015 TCB Workshop Notes (Simultaneous transmission summation clarified)
- October 2016 TCB Workshop Notes (Bluetooth Duty Factor)

1.2 Device Overview

Band & Mode	Operating Modes	Tx Frequency
GSM/GPRS 850	Voice/Data	824.2 ~ 848.8 MHz
GSM/GPRS 1900	Voice/Data	1850.2 ~ 1909.8 MHz
WCDMA 850	Voice/Data	826.4 ~ 846.6 MHz
WCDMA 1700	Voice/Data	1712.4 ~ 1752.6 MHz
WCDMA 1900	Voice/Data	1852.4 ~ 1907.6 MHz
LTE Band 17	Voice/Data	706.5 ~ 713.5 MHz
LTE Band 13	Voice/Data	779.5 ~ 784.5 MHz
LTE Band 5	Voice/Data	824.7 ~ 848.3 MHz
2.4 GHz WLAN	Voice/Data	2412 ~ 2462 MHz
5.2 GHz WLAN (U-NII-1)	Voice/Data	5180 ~ 5240 MHz
5.3 GHz WLAN (U-NII-2A)	Voice/Data	5260 ~ 5320 MHz
5.6 GHz WLAN (U-NII-2C)	Voice/Data	5500 ~ 5720 MHz
5.8 GHz WLAN (U-NII-3)	Voice/Data	5745 ~ 5825 MHz
Bluetooth	Data	2402 ~ 2480 MHz
NFC	Data	13.56 MHz

1.3 Nominal and Maximum Output Power Specifications

This device operates using the following maximum and nominal output power specifications. SAR values were scaled to the maximum allowed power to determine compliance per KDB Publication 447498 D01v06

(A) GSM/GPRS/EDGE 850/1900

Band & Mode		Voice [dBm]	Burst Average GMSK [dBm]				Burst Average 8-PSK [dBm]			
			1 TX Slot	2 TX Slot	3 TX Slot	4 TX Slot	1 TX Slot	2 TX Slot	3 TX Slot	4 TX Slot
GSM/GPRS/EDGE 850	Maximum	33.7	33.7	31.7	29.7	27.7	25.7	25.7	24.7	23.7
	Nominal	33.2	33.2	31.2	29.2	27.2	25.2	25.2	24.2	23.2
GSM/GPRS/EDGE 1900	Maximum	31.7	31.7	29.7	27.7	25.7	25.7	25.7	24.7	23.7
	Nominal	31.2	31.2	29.2	27.2	25.2	25.2	25.2	24.2	23.2

(B) WCDMA/HSDPA/HSUPA/DC-HSDPA

Band & Mode		Modulated Average [dBm]		
		3GPP WCDMA (Rel.99)	3GPP HSDPA	3GPP HSUPA
WCDMA 850	Maximum	25.2	25.2	25.2
	Nominal	24.7	24.7	24.7
WCDMA 1700	Maximum	23.2	23.2	23.2
	Nominal	22.7	22.7	22.7
WCDMA 1900	Maximum	23.2	23.2	23.2
	Nominal	22.7	22.7	22.7

Note : This device supports HSDPA and HSUPA but the manufacturer declares on the tune-up procedure that the HSDPA and HSUPA transmitter's power will not exceed the R99 maximum transmit power in devices based on Qualcomm's HSPA chipset solution.

(C) LTE

Band & Mode		Modulated Average [dBm]
LTE Band 17	Maximum	25.2
	Nominal	24.7
LTE Band 13	Maximum	24.2
	Nominal	23.7
LTE Band 5(Cell)	Maximum	25.2
	Nominal	24.7

(D) 2.4G WLAN

Band (GHz)	Mode	Ch	Modulated Average[dBm]					
			Ant.1		Ant.2		MIMO(CDD/SDM)	
			Maximum	Nominal	Maximum	Nominal	Maximum	Nominal
2.4	802.11b	1~2	16.0	15.0	16.0	15.0	19.0	18.0
		3~9	16.0	15.0	16.0	15.0	19.0	18.0
		10~11	16.0	15.0	16.0	15.0	19.0	18.0
	802.11g	1~2	16.0	15.0	16.0	15.0	19.0	18.0
		3~9	16.0	15.0	16.0	15.0	19.0	18.0
		10~11	16.0	15.0	16.0	15.0	19.0	18.0
	802.11n	1~2	15.0	14.0	15.0	14.0	18.0	17.0
		3~9	15.0	14.0	15.0	14.0	18.0	17.0
		10~11	15.0	14.0	15.0	14.0	18.0	17.0
	802.11ac	1~2	15.0	14.0	15.0	14.0	18.0	17.0
		3~9	15.0	14.0	15.0	14.0	18.0	17.0
		10~11	15.0	14.0	15.0	14.0	18.0	17.0

(E) 5G WLAN

Band (GHz)	Mode	Ch	Modulated Average[dBm]					
			Ant.1		Ant.2		MIMO(CDD/SDM)	
			Maximum	Nominal	Maximum	Nominal	Maximum	Nominal
5	802.11a	36	16.0	15.0	16.0	15.0	19.0	18.0
		40-48	16.0	15.0	16.0	15.0	19.0	18.0
		52-60	16.0	15.0	16.0	15.0	19.0	18.0
		64	16.0	15.0	16.0	15.0	19.0	18.0
		100	16.0	15.0	16.0	15.0	19.0	18.0
		104-144	16.0	15.0	16.0	15.0	19.0	18.0
		149-161	16.0	15.0	16.0	15.0	19.0	18.0
		165	16.0	15.0	16.0	15.0	19.0	18.0
	802.11n/ac (20MHz)	36	15.0	14.0	15.0	14.0	18.0	17.0
		40-48	15.0	14.0	15.0	14.0	18.0	17.0
		52-60	15.0	14.0	15.0	14.0	18.0	17.0
		64	15.0	14.0	15.0	14.0	18.0	17.0
		100	15.0	14.0	15.0	14.0	18.0	17.0
		104-144	15.0	14.0	15.0	14.0	18.0	17.0
		149-161	15.0	14.0	15.0	14.0	18.0	17.0
		165	15.0	14.0	15.0	14.0	18.0	17.0
	802.11n/ac (40MHz)	38	15.0	14.0	15.0	14.0	18.0	17.0
		46	15.0	14.0	15.0	14.0	18.0	17.0
		54	15.0	14.0	15.0	14.0	18.0	17.0
		62	15.0	14.0	15.0	14.0	18.0	17.0
		102	15.0	14.0	15.0	14.0	18.0	17.0
		110	15.0	14.0	15.0	14.0	18.0	17.0
		134	15.0	14.0	15.0	14.0	18.0	17.0
		142	15.0	14.0	15.0	14.0	18.0	17.0
		151	15.0	14.0	15.0	14.0	18.0	17.0
		159	15.0	14.0	15.0	14.0	18.0	17.0
	802.11ac (80MHz)	42	15.0	14.0	15.0	14.0	18.0	17.0
		58	15.0	14.0	15.0	14.0	18.0	17.0
106		15.0	14.0	15.0	14.0	18.0	17.0	
138		15.0	14.0	15.0	14.0	18.0	17.0	
155		15.0	14.0	15.0	14.0	18.0	17.0	

(F) BT

Modulated Average[dBm]		
Bluetooth 1 Mbps	Maximum	11.5
	Nominal	10.5
Bluetooth 2 Mbps	Maximum	11.0
	Nominal	10.0
Bluetooth 3 Mbps	Maximum	11.0
	Nominal	10.0
Bluetooth LE	Maximum	2.5
	Nominal	1.5

1.4 DUT Antenna Locations

The overall dimensions of this device are > 9 x 5 cm. A diagram showing the location of the device of the device antenna can be found in ZNFQVR_Antenna Location.pdf. Since the diagonal dimension of this device is > 160 mm and < 200 mm. it is considered a “phablet”.

Mode	Device Sides for SAR Testing					
	Top	Bottom	Front	Rear	Right	Left
GSM 850	X	O	O	O	O	O
GSM 1900	X	O	O	O	X	O
WCDMA 850	X	O	O	O	O	O
WCDMA 1700	X	O	O	O	X	O
WCDMA 1900	X	O	O	O	X	O
LTE Band 17	X	O	O	O	O	O
LTE Band 13	X	O	O	O	O	O
LTE Band 5	X	O	O	O	O	O
2.4G W-LAN Ant.1	O	X	O	O	X	O
2.4G W-LAN Ant.2	O	X	O	O	X	O
2.4G W-LAN MIMO	O	X	O	O	X	O
5G W-LAN Ant.1	O	X	O	O	X	O
5G W-LAN Ant.2	O	X	O	O	X	O
5G W-LAN MIMO	O	X	O	O	X	O

Note 1: Particular DUT edges were not required to be evaluated for Hotspot SAR or Phablet SAR if the edges were greater than 2.5 cm from the transmitting antenna according to FCC KDB Publication 648474 D04v01r03. The antenna document shows the distances between the transmit antennas and the edges of the device.

Note 2: WLAN Hotspot UNII-1, 3 supported.

1.5 Near Field Communications (NFC) Antenna

This DUT has NFC operations. The NFC antenna is integrated into the back side. The SAR tests were performed with with NFC antenna already incorporated. A diagram showing the location of the device of the device antenna can be found in ZNFQVR_Antenna Location.pdf.

1.6 SAR Test Exclusions Applied

(A) Licensed Transmitter(s)

GSM/GPRS DTM is not supported for US bands. Therefore, the GSM Voice modes in this report do not transmit simultaneously with GPRS Data.

1.7 Power Reduction for SAR

There is no power reduction used for any band/mode implemented in this device for SAR purposes.

1.8 Device Serial Numbers

Band & Mode	Head Serial Number	Body Serial Number	Hotspot Serial Number	Phablet Serial Number
GSM/GPRS 850	FCC #1	FCC #1	FCC #1	-
GSM/GPRS 1900	FCC #1	FCC #1	FCC #1	-
WCDMA 850	FCC #1	FCC #1	FCC #1	-
WCDMA 1700	FCC #1	FCC #1	FCC #1	-
WCDMA 1900	FCC #1	FCC #1	FCC #1	-
LTE Band 17	FCC #1	FCC #1	FCC #1	-
LTE Band 13	FCC #1	FCC #1	FCC #1	-
LTE Band 5	FCC #1	FCC #1	FCC #1	-
2.4 GHz WLAN	FCC #2	FCC #2	FCC #2	-
5 GHz WLAN	FCC #2	FCC #2	FCC #2	FCC #2

1.9 LTE Information

LTE Information					
FCC ID	ZNFQVR				
Form Factor	Mobile Phone				
Frequency Range of each LTE transmission Band	LTE Band 17 (706.5 ~ 713.5 MHz) LTE Band 13 (779.5 ~ 784.5 MHz) LTE Band 5 (Cell) (824.7 ~ 848.3 MHz)				
Channel Bandwidths	LTE Band 17 (706.5 ~ 713.5 MHz): 5 MHz, 10 MHz LTE Band 13 (779.5 ~ 784.5 MHz): 5 MHz, 10 MHz LTE Band 5 (Cell): 1.4 MHz, 3 MHz, 5 MHz, 10 MHz				
Channel Number and Frequencies(MHz)	Low	Low-Mid	Mid	Mid-High	High
LTE Band 17: 5 MHz	706.5(23755)	N/A	710.0(23790) ^{Note1}	N/A	713.5(23825)
LTE Band 17: 10 MHz	709.0(23780)	N/A	710.0(23790) ^{Note1}	N/A	711.0(23800)
LTE Band 13: 5 MHz	779.5 (23205)	N/A	782.0 (23230) ^{Note2}	N/A	784.5 (23255)
LTE Band 13: 10 MHz	N/A	N/A	782.0 (23230)	N/A	N/A
LTE Band 5 (Cell): 1.4 MHz	824.7 (20407)	N/A	836.5 (20525)	N/A	848.3 (20643)
LTE Band 5 (Cell): 3 MHz	825.5 (20415)	N/A	836.5 (20525)	N/A	847.5 (20635)
LTE Band 5 (Cell): 5 MHz	826.5 (20425)	N/A	836.5 (20525)	N/A	846.5 (20625)
LTE Band 5 (Cell): 10 MHz	829.0 (20450)	N/A	836.5 (20525) ^{Note3}	N/A	844.0 (20600)
UE Category	LTE Rel.12, UL Category 13, DL Category 16				
Modulations Supported in UL	QPSK, 16QAM, 64QAM				
LTE MPR Permanently implemented per 3GPP TS 36.101 section 6.2.3~6.2.5? (manufacturer attestation to be provided)	Yes				
A-MPR (Additional MPR) disabled for SAR Testing?	LTE A-MPR is disabled.				
Power reduction explanation	This device doesn't implements power reduction.				
LTE Carrier Aggregation Possible Combinations	LTE Carrier Aggregation is not supported.				
LTE Release 11 Additional Information	This device does not support CA features on 3GPP Release 12. All uplink communications are identical to the Release 8 Specifications. The following LTE Release 12 Features are not supported: Relay, HetNet, Enhanced MIMO, eICIC, WIFI Offloading, MDH, eMBMS, Cross-Carrier Scheduling, Enhanced SC-FDMA.				

Note(s)

- LTE Band 17 at 10 MHz/5 MHz bandwidth does not support three non-overlapping channels.
Per KDB 941225 D05v02r05, when a device supports overlapping channel assignment in a channel bandwidth configuration, the middle channel of the group of overlapping channels should be selected for testing.
- LTE Band 13 at 5 MHz bandwidth does not support three non-overlapping channels.
Per KDB 941225 D05v02r05, when a device supports overlapping channel assignment in a channel bandwidth configuration, the middle channel of the group of overlapping channels should be selected for testing.
- LTE Band 5 (Cell) at 10 MHz bandwidth does not support three non-overlapping channels.
Per KDB 941225 D05v02r05, when a device supports overlapping channel assignment in a channel bandwidth configuration, the middle channel of the group of overlapping channels should be selected for testing.

2. INTROCUCTION

The FCC and Industry Canada have adopted the guidelines for evaluating the environmental effects of radio frequency (RF) radiation in ET Docket 93-62 on Aug. 6, 1996 and Health Canada Safety Code 6 to protect the public and workers from the potential hazards of RF emissions due to FCC-regulated portable devices.

The FCC has adopted the guidelines for evaluating the environmental effects of radio frequency radiation in ET Docket 93-62 on Aug. 6, 1996 to protect the public and workers from the potential hazards of RF emissions due to FCC-regulated portable devices. The safety limits used for the environmental evaluation measurements are based on the criteria published by the American National Standards Institute (ANSI) for localized specific absorption rate (SAR) in IEEE/ANSI C95.1-1992 Standard for Safety Levels with Respect to Human Exposure to Radio Frequency Electromagnetic Fields, 3 kHz to 300 GHz. The measurement procedure described in IEEE/ANSI C95.3-2002 Recommended Practice for the Measurement of Potentially Hazardous Electromagnetic Fields - RF and Microwave is used for guidance in measuring SAR due to the RF radiation exposure from the Equipment Under Test (EUT). These criteria for SAR evaluation are similar to those recommended by the National Council on Radiation Protection and Measurements (NCRP) in Biological Effects and Exposure Criteria for Radio frequency Electromagnetic Fields," NCRP Report No. 86 NCRP, 1986, Bethesda, MD 20814. SAR is a measure of the rate of energy absorption due to exposure to an RF transmitting source. SAR values have been related to threshold levels for potential biological hazards.

SAR Definition

Specific Absorption Rate (SAR) is defined as the time derivative (rate) of the incremental energy (dU) absorbed by (dissipated in) an incremental mass (dm) contained in a volume element (dV) of a given density (ρ) It is also defined as the rate of RF energy absorption per unit mass at a point in an absorbing body (see Fig. 2.1)

$$SAR = \frac{d}{dt} \left(\frac{dU}{dm} \right) = \frac{d}{dt} \left(\frac{dU}{\rho dv} \right)$$

Fig. 2.1 SAR Mathematical Equation

SAR is expressed in units of Watts per Kilogram (W/kg).

$$SAR = \frac{\sigma \cdot E^2}{\rho}$$

where:

- σ = conductivity of the tissue-simulating material (S/m)
- ρ = mass density of the tissue-simulating material (kg/m³)
- E = Total RMS electric field strength (V/m)

NOTE: The primary factors that control rate of energy absorption were found to be the wavelength of the incident field in relations to the dimensions and geometry of the irradiated organism, the orientation of the organism in relation to the polarity of field vectors, the presence of reflecting surfaces, and whether conductive contact is made by the organism with a ground plane.

3. DESCRIPTION OF TEST EQUIPMENT

3.1 SAR MEASUREMENT SETUP

Measurements are performed using the DASY5 automated dosimetric assessment system. The DASY5 is made by Schmid & Partner Engineering AG (SPEAG) in Zurich, Switzerland and consists of high precision robotics system (Staubli), robot controller, desktop computer, near-field probe, probe alignment sensor, and the generic twin phantom containing the brain equivalent material. The robot is a six-axis industrial robot performing precise movements to position the probe to the location (points) of maximum electromagnetic field (EMF) (see Fig. 3.1).

A cell controller system contains the power supply, robot controller each pendant (Joystick), and a remote control used to drive the robot motors. The PC consists of the Intel Core i7-3770 3.40 GHz desktop computer with Windows 7 system and SAR Measurement Software DASY5, A/D interface card, monitor, mouse, and keyboard. The Staubli Robot is connected to the cell controller to allow software manipulation of the robot. A data acquisition electronic (DAE) circuit that performs the signal amplification, signal multiplexing, AD-conversion, offset measurements, mechanical surface detection, collision detection, etc. is connected to the Electro-optical coupler (EOC). The EOC performs the conversion from the optical into digital electric signal of the DAE and transfers data to the PC plug-in card.

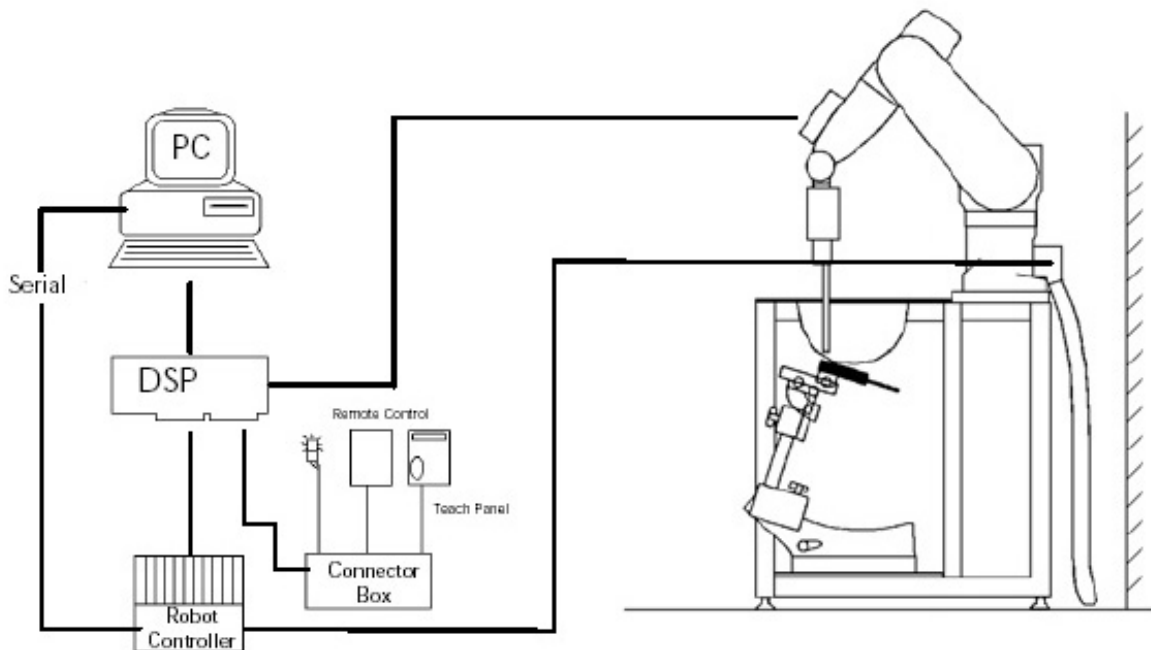

Figure 3.1 SAR Measurement System Setup

The DAE4 consists of a highly sensitive electrometer-grade preamplifier with auto-zeroing, a channel and gain-switching multiplexer, a fast 16 bit AD-converter and a command decoder and control logic unit. Transmission to the PC-card is accomplished through an optical downlink for data and status information and an optical uplink for commands and clock lines. The mechanical probe mounting device includes two different sensor systems for frontal and sidewise probe contacts. They are also used for mechanical surface detection and probe collision detection. The robot uses its own controller with a built in VME-bus computer. The system is described in detail.

3.2 ES3DV3/EX3DV4 Probe Specification

Calibration	In air from 10 MHz to 4 GHz/10 MHz to 6 GHz In brain and muscle simulating tissue at Frequencies of 750 MHz, 835 MHz, 900 MHz, 1750 MHz, 1900 MHz, 2450 MHz, 2600 MHz/ 2450 MHz, 2600 MHz, 5200 MHz, 5300 MHz, 5500 MHz, 5600 MHz, 5800 MHz
Frequency	10 MHz to 4 GHz/10 MHz to 6 GHz
Linearity	± 0.2 dB(30 MHz to 4 GHz/30 MHz to 6 GHz)
Dynamic	10 μW/g to > 100 mW/g
Range	Linearity : ±0.2dB
Dimensions	Overall length : 337 mm
Tip length	20 mm
Body diameter	12 mm
Tip diameter	3.9 mm/2.5 mm
Distance from probe tip to sensor center	2.0 mm/1.0 mm
Application	SAR Dosimetry Testing Compliance tests of mobile phones

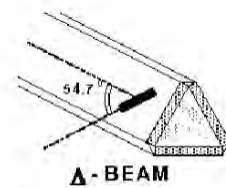

Figure 3.2 Triangular Probe Configurations



Figure 3.3 Probe Thick-Film Technique



DAE System

The SAR measurements were conducted with the dosimetric probe ES3DV3 and EX3DV4, designed in the classical triangular configuration(see Fig. 3.2) and optimized for dosimetric evaluation. The probe is constructed using the thick film technique; with printed resistive lines on ceramic substrates. The probe is equipped with an optical multitier line ending at the front of the probe tip. It is connected to the EOC box on the robot arm and provides an automatic detection of the phantom surface. Half of the fibers are connected to a pulsed infrared transmitter, the other half to a synchronized receiver. As the probe approaches the surface, the reflection from the surface produces a coupling from the transmitting to the receiving fibers. This reflection increases first during the approach, reaches maximum and then decreases. If the probe is flatly touching the surface, the coupling is zero. The distance of the coupling maximum to the surface is independent of the surface reflectivity and largely independent of the surface to probe angle. The DASY5 software reads the reflection during a software approach and looks for the maximum using a 2nd order fitting. The approach is stopped at reaching the maximum.

3.3 Probe Calibration Process

3.3.1 E-Probe Calibration

Dosimetric Assessment Procedure

Each probe is calibrated according to a dosimetric assessment procedure with accuracy better than +/- 10%. The spherical isotropy was evaluated with the procedure and found to be better than +/-0.25dB. The sensitivity parameters (Norm X, Norm Y, Norm Z), the diode compression parameter (DCP) and the conversion factor (Conv F) of the probe is tested.

Free Space Assessment

The free space E-field from amplified probe outputs is determined in a test chamber. This is performed in a TEM cell for frequencies below 1 GHz, and in a waveguide above 1GHz for free space. For the free space calibration, the probe is placed in the volumetric center of the cavity at the proper orientation with the field. The probe is then rotated 360 degrees.

Temperature Assessment *

E-field temperature correlation calibration is performed in a flat phantom filled with the appropriate simulated brain tissue. The measured free space E-field in the medium, correlates to temperature rise in a dielectric medium. For temperature correlation calibration a RF transparent the remits or based temperature probe is used in conjunction with the E-field probe.

$$SAR = C \frac{\Delta T}{\Delta t}$$

where:

Δt = exposure time (30 seconds),

C = heat capacity of tissue (brain or muscle),

ΔT = temperature increase due to RF exposure.

$$SAR = \frac{|E|^2 \cdot \sigma}{\rho}$$

where:

σ = simulated tissue conductivity,

ρ = Tissue density (1.25 g/cm³ for brain tissue)

SAR is proportional to $\Delta T / \Delta t$, the initial rate of tissue heating, before thermal diffusion takes place. Now it's possible to quantify the electric field in the simulated tissue by equating the thermally derived SAR to the E- field;

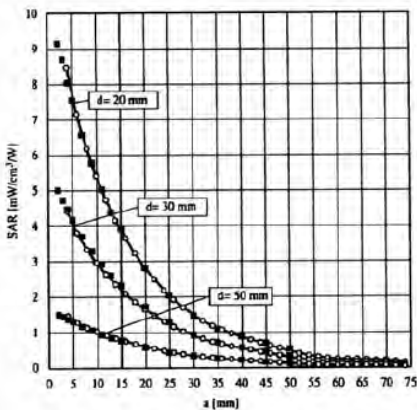

Figure 3.4 E-Field and Temperature Measurements at 900MHz

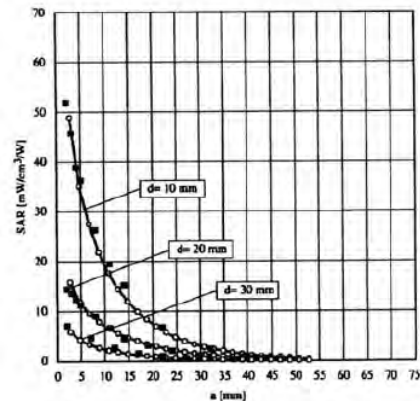

Figure 3.5 E-Field and Temperature Measurements at 1800MHz

3.4 Data Extrapolation

The DASY5 software automatically executes the following procedures to calculate the field units from the microvolt readings at the probe connector. The first step of the evaluation is a linearization of the filtered input signal to account for the compression characteristics of the detector diode. The compensation depends on the input signal, the diode type and the DC-transmission factor from the diode to the evaluation electronics. If the exciting field is pulsed, the crest factor of the signal must be known to correctly compensate for peak power. The formula for each channel can be given like below;

$$V_i = U_i + U_i^2 \cdot \frac{cf}{dcp_i}$$

with V_i = compensated signal of channel i (i=x,y,z)
 U_i = input signal of channel i (i=x,y,z)
 cf = crest factor of exciting field (DASY parameter)
 dcp_i = diode compression point (DASY parameter)

From the compensated input signals the primary field data for each channel can be evaluated:

E-field probes:

$$E_i = \sqrt{\frac{V_i}{Norm_i \cdot ConvF}}$$

with V_i = compensated signal of channel i (i = x,y,z)
 $Norm_i$ = sensor sensitivity of channel i (i = x,y,z)
 $\mu V/(V/m)^2$ for E-field probes
 $ConvF$ = sensitivity of enhancement in solution
 E_i = electric field strength of channel i in V/m

The RSS value of the field components gives the total field strength (Hermetian magnitude):

$$E_{tot} = \sqrt{E_x^2 + E_y^2 + E_z^2}$$

The primary field data are used to calculate the derived field units.

$$SAR = E_{tot}^2 \cdot \frac{\sigma}{\rho \cdot 1000}$$

with SAR = local specific absorption rate in W/g
 E_{tot} = total field strength in V/m
 σ = conductivity in [mho/m] or [Siemens/m]
 ρ = equivalent tissue density in g/cm³

The power flow density is calculated assuming the excitation field to be a free space field.

$$P_{free} = \frac{E_{tot}^2}{3770}$$

with P_{pwe} = equivalent power density of a plane wave in W/cm²
 E_{tot} = total electric field strength in V/m

3.5 SAM Twin PHANTOM

The SAM Twin Phantom V5.0 is constructed of a fiberglass shell integrated in a wooden table. The shape of the shell is based on data from an anatomical study designed to determine the maximum exposure in at least 90% of all users. It enables the dosimetric evaluation of left and right hand phone usage as well as body mounted usage at the flat phantom region. A cover prevents the evaporation of the liquid.

Reference markings on the Phantom allow the complete setup of all predefined phantom positions and measurement grids by manually teaching three points in the robot. (see Fig. 3.6)



Figure 3.6 SAM Twin Phantom

SAM Twin Phantom Specification:

Construction	The shell corresponds to the specifications of the Specific Anthropomorphic Mannequin (SAM) phantom defined in IEEE 1528 and IEC 62209-1. It enables the dosimetric evaluation of left and right hand phone usage as well as body mounted usage at the flat phantom region. A cover prevents evaporation of the liquid. Reference markings on the phantom allow the complete setup of all predefined phantom positions and measurement grids by teaching three points with the robot. Twin SAM V5.0 has the same shell geometry and is manufactured from the same material as Twin SAM V4.0, but has reinforced top structure.
Shell Thickness	2 ± 0.2 mm
Filling Volume	Approx. 25 liters
Dimensions	Length: 1000 mm Width: 500 mm Height: adjustable feet

Specific Anthropomorphic Mannequin (SAM) Specifications:

The phantom for handset SAR assessment testing is a low-loss dielectric shell, with shape and dimensions derived from the anthropometric data of the 90th percentile adult male head dimensions as tabulated by the US Army. The SAM Twin Phantom shell is bisected along the mid-sagittal plane into right and left halves (see Fig. 3.7). The perimeter sidewalls of each phantom halves are extended to allow filling with liquid to a depth that is sufficient to minimized reflections from the upper surface. The liquid depth is maintained at a minimum depth of 15cm to minimize reflections from the upper surface.



Figure 3.7 Sam Twin Phantom shell

3.6 Device Holder for Transmitters

In combination with the Twin SAM Phantom V4.0/V4.0c, V5.0 or ELI4, the Mounting Device enables the rotation of the mounted transmitter device in spherical coordinates. Rotation point is the ear opening point. Transmitter devices can be easily and accurately positioned according to IEC, IEEE, FCC or other specifications. The device holder can be locked for positioning at different phantom sections (left head, right head, flat).

Note: A simulating human hand is not used due to the complex anatomical and geometrical structure of the hand that may produce infinite number of configurations. To produce the worst-case condition (the hand absorbs antenna output power), the hand is omitted during the tests.



Figure 3.8 Mounting Device

3.7 Brain & Muscle Simulation Mixture Characterization

The brain and muscle mixtures consist of a viscous gel using hydrox-ethylcellulose (HEC) gelling agent and saline solution (see Table 3.1). Preservation with a bactericide is added and visual inspection is made to make sure air bubbles are not trapped during the mixing process. The mixture is calibrated to obtain proper dielectric constant (permittivity) and conductivity of the desired tissue. The mixture characterizations used for the brain and muscle tissue simulating liquids are according to the data by C. Gabriel and G. Harts grove.



Figure 3.9 Simulated Tissue

Table3.1 Composition of the Tissue Equivalent Matter

Ingredients (% by weight)	Frequency (MHz)							
	835		1900		2450		5200 ~ 5800	
Tissue Type	Head	Body	Head	Body	Head	Body	Head	Body
Water	40.19	50.75	55.24	70.23	71.88	73.40	65.52	80.00
Salt (NaCl)	1.480	0.940	0.310	0.290	0.160	0.060	-	-
Sugar	57.90	48.21	-	-	-	-	-	-
HEC	0.250	-	-	-	-	-	-	-
Bactericide	0.180	0.100	-	-	-	-	-	-
Triton X-100	-	-	-	-	19.97	-	17.24	-
DGBE	-	-	44.45	29.48	7.990	26.54	-	-
Diethylene glycol hexyl ether	-	-	-	-	-	-	17.24	-
Polysorbate (Tween) 80	-	-	-	-	-	-	-	20.00
Target for Dielectric Constant	41.5	55.2	40.0	53.3	39.2	52.7	-	-
Target for Conductivity (S/m)	0.90	0.97	1.40	1.52	1.80	1.95	-	-

Salt:	99 % Pure Sodium Chloride	Sugar:	98 % Pure Sucrose
Water:	De-ionized, 16M resistivity	HEC:	Hydroxyethyl Cellulose
DGBE:	99 % Di(ethylene glycol) butyl ether,[2-(2-butoxyethoxy) ethanol]		
Triton X-100(ultra pure):	Polyethylene glycol mono[4-(1,1,3,3-tetramethylbutyl)phenyl] ether		

Table3.2 HSL/MSL750 (Head and Body liquids for 700 – 800 MHz)

Item	Head Tissue Simulation Liquids HSL750
	Muscle (body) Tissue Simulation Liquids MSL750
Type No	SL AAH 075, SL AAM 075
Manufacturer	SPEAG
The item is composed of the following ingredients:	
H ² O	Water, 35 – 58%
Sucrose	Sucrose, 40 – 60%
NaCl	Sodium Chloride, 0 – 6%
Hydroxyethyl-cellulose	Medium Viscosity (CAS# 9004-62-0), < 0.3%
Preventol-D7	Preservative: aqueous preparation, (CAS# 55965-84-9), containing 5-chloro-2-methyl-3(2H)-isothiazolone and 2-methyl-3(2H)-isothiazolone, 0.1 – 0.6%

Table3.3 HSL/MSL1750 (Head and Body liquids for 1700 – 1800 MHz)

Item	Head Tissue Simulation Liquids HSL1750
	Muscle (body) Tissue Simulation Liquids MSL1750
Type No	SL AAH 175, SL AAM 175
Manufacturer	SPEAG
The item is composed of the following ingredients:	
H ² O	Water, 52 – 75%
C ₈ H ₁₈ O ₃	Diethylene glycol monobutyl ether (DGBE), 25 – 48%
NaCl	Sodium Chloride, < 1.0%

3.8 SAR TEST EQUIPMENT

Table 3.2 Test Equipment Calibration

	Type	Manufacturer	Model	Cal.Date	Next.Cal.Date	S/N
<input checked="" type="checkbox"/>	SEMITEC Engineering	SEMITEC	N/A	N/A	N/A	Shield Room
<input checked="" type="checkbox"/>	SEMITEC Engineering	SEMITEC	N/A	N/A	N/A	Shield Room
<input checked="" type="checkbox"/>	Robot	SCHMID	TX90XL	N/A	N/A	F13/5P9GA1/A/01
<input checked="" type="checkbox"/>	Robot	SCHMID	TX90XL	N/A	N/A	F13/5RR2A1/A/01
<input checked="" type="checkbox"/>	Robot Controller	SCHMID	CS8C	N/A	N/A	F13/5P9GA1/C/01
<input checked="" type="checkbox"/>	Robot Controller	SCHMID	CS8C	N/A	N/A	F13/5RR2A1/C/01
<input checked="" type="checkbox"/>	Joystick	SCHMID	N/A	N/A	N/A	S-12450905
<input checked="" type="checkbox"/>	Joystick	SCHMID	N/A	N/A	N/A	S-13200990
<input checked="" type="checkbox"/>	IntelCorei7-3770 3.40 GHz Windows 7 Professional	N/A	N/A	N/A	N/A	N/A
<input checked="" type="checkbox"/>	IntelCorei7-3770 3.40 GHz Windows 7 Professional	N/A	N/A	N/A	N/A	N/A
<input checked="" type="checkbox"/>	Probe Alignment Unit LB	N/A	N/A	N/A	N/A	SE UKS 030 AA
<input checked="" type="checkbox"/>	Probe Alignment Unit LB	N/A	N/A	N/A	N/A	SE UKS 030 AA
<input checked="" type="checkbox"/>	Device Holder	SCHMID	Holder	N/A	N/A	SD000H01HA
<input checked="" type="checkbox"/>	Device Holder	SCHMID	Holder	N/A	N/A	SD000H01HA
<input checked="" type="checkbox"/>	Twin SAM Phantom	SCHMID	QD000P40CD	N/A	N/A	1783
<input checked="" type="checkbox"/>	Twin SAM Phantom	SCHMID	QD000P40CD	N/A	N/A	1782
<input checked="" type="checkbox"/>	Twin SAM Phantom	SCHMID	QD000P40CD	N/A	N/A	1786
<input checked="" type="checkbox"/>	Data Acquisition Electronics	SCHMID	DAE3V1	2017-01-20	2018-01-20	519
<input checked="" type="checkbox"/>	Data Acquisition Electronics	SCHMID	DAE4V1	2017-07-24	2018-07-24	1335
<input checked="" type="checkbox"/>	Dosimetric E-Field Probe	SCHMID	ES3DV3	2017-03-21	2018-03-21	3328
<input checked="" type="checkbox"/>	Dosimetric E-Field Probe	SCHMID	EX3DV4	2017-07-26	2018-07-26	3930
<input checked="" type="checkbox"/>	750MHz SAR Dipole	SCHMID	D750V3	2017-01-18	2019-01-18	1049
<input checked="" type="checkbox"/>	835MHz SAR Dipole	SCHMID	D835V2	2016-09-28	2018-09-28	4d159
<input checked="" type="checkbox"/>	1800MHz SAR Dipole	SCHMID	D1800V2	2017-05-23	2019-05-23	2d047
<input checked="" type="checkbox"/>	1900MHz SAR Dipole	SCHMID	D1900V2	2016-09-28	2018-09-28	5d176
<input checked="" type="checkbox"/>	2450MHz SAR Dipole	SCHMID	D2450V2	2016-09-23	2018-09-23	920
<input checked="" type="checkbox"/>	5GHz SAR Dipole	SCHMID	D5GHzV2	2017-03-17	2019-03-17	1103
<input checked="" type="checkbox"/>	Network Analyzer	Agilent	E5071C	2016-12-02	2017-12-02	MY46111534
<input checked="" type="checkbox"/>	Signal Generator	Agilent	E4438C	2016-09-09	2017-09-09	US41461520
				2017-09-05	2018-09-05	
<input checked="" type="checkbox"/>	Amplifier	EMPOWER	BBS3Q7ELU	2016-09-08	2017-09-08	1020
				2017-09-06	2018-09-06	
<input checked="" type="checkbox"/>	High Power RF Amplifier	EMPOWER	BBS3Q8CCJ	2016-10-18	2017-10-18	1005
<input checked="" type="checkbox"/>	Power Meter	HP	EPM-442A	2017-01-04	2018-01-04	GB37170267
<input checked="" type="checkbox"/>	Power Meter	HP	EPM-442A	2017-04-11	2018-04-11	GB37170413
<input checked="" type="checkbox"/>	Power Sensor	HP	8481A	2017-01-04	2018-01-04	3318A96566
<input checked="" type="checkbox"/>	Power Sensor	HP	8481A	2017-01-04	2018-01-04	2702A65976
<input checked="" type="checkbox"/>	Power Sensor	HP	8481A	2017-04-11	2018-04-11	3318A96332
<input checked="" type="checkbox"/>	Dual Directional Coupler	Agilent	778D-012	2017-01-05	2018-01-05	50228
<input checked="" type="checkbox"/>	Directional Coupler	HP	772D	2017-07-26	2018-07-26	2889A01064
<input checked="" type="checkbox"/>	Low Pass Filter 1.5GHz	Micro LAB	LA-15N	2017-01-04	2018-01-04	N/A
<input checked="" type="checkbox"/>	Low Pass Filter 3.0GHz	Micro LAB	LA-30N	2017-09-05	2018-09-05	N/A
<input checked="" type="checkbox"/>	Low Pass Filter 6.0GHz	Micro LAB	LA-60N	2017-01-04	2018-01-04	03942
<input checked="" type="checkbox"/>	Attenuators(3 dB)	Agilent	8491B	2017-04-11	2018-04-11	MY39260700
<input checked="" type="checkbox"/>	Attenuators(10 dB)	WEINSCHTEL	23-10-34	2017-01-04	2018-01-04	BP4387
<input checked="" type="checkbox"/>	Dielectric Probe kit	SCHMID	DAK-3.5	2016-11-17	2017-11-17	1092
<input checked="" type="checkbox"/>	Dielectric Probe kit	SCHMID	DAK-3.5	2017-07-26	2018-07-26	1046
<input checked="" type="checkbox"/>	8960 Series 10 Wireless Comms. Test Set	Agilent	E5515C	2016-09-09	2017-09-09	GB41321164
				2017-09-05	2018-09-05	
<input checked="" type="checkbox"/>	Wideband Radio Communication Tester	Rohde Schwarz	CMW500	2017-08-04	2018-08-04	152048
<input checked="" type="checkbox"/>	Power Splitter	Anritsu	K241B	2017-01-11	2018-01-11	1301183
<input checked="" type="checkbox"/>	Bluetooth Tester	TESCOM	TC-3000B	2017-01-04	2018-01-04	3000B770243

NOTE: The E-field probe was calibrated by SPEAG, by temperature measurement procedure. Dipole Verification measurement is performed by DT&C before each test. The brain and muscle simulating material are calibrated by DT&C using the dielectric probe system and network analyzer to determine the conductivity and permittivity (dielectric constant) of the brain-equivalent material. Each equipment item was used solely within its respective calibration period.

4. TEST SYSTEM SPECIFICATIONS

Automated TEST SYSTEM SPECIFICATIONS:

Positioner

Robot	Stäubli Unimation Corp. Robot Model: TX90XL
Repeatability	0.02 mm
No. of axis	6

Data Acquisition Electronic (DAE) System

Cell Controller

Processor	Intel Core i7-3770
Clock Speed	3.40 GHz
Operating System	Windows 7 Professional
Data Card	DASY5 PC-Board

Data Converter

Features	Signal, multiplexer, A/D converter. & control logic
Software	DASY5
Connecting Lines	Optical downlink for data and status info Optical uplink for commands and clock

PC Interface Card

Function	24 bit (64 MHz) DSP for real time processing Link to DAE 4 16 bit A/D converter for surface detection system serial link to robot direct emergency stop output for robot
-----------------	--

E-Field Probes

Model	ES3DV3 S/N: 3328/ EX3DV4 S/N: 3930
Construction	Triangular core fiber optic detection system
Frequency	10 MHz to 4 GHz/10 MHz to 6 GHz
Linearity	± 0.2 dB (30 MHz to 4 GHz/30 MHz to 6 GHz)

Phantom

Phantom	SAM Twin Phantom (V5.0)
Shell Material	Composite
Thickness	2.0 ± 0.2 mm



Figure 4.1 DASY5 Test System

5. SAR MEASUREMENT PROCEDURE

5.1 Measurement Procedure

The evaluation was performed using the following procedure compliant to FCC KDB Publication 865664 D01v01r04 and IEEE 1528-2013:

1. The SAR distribution at the exposed side of the head or body was measured at a distance no greater than 5.0 mm from the inner surface of the shell. The area covered the entire dimension of the device-head and body interface and the horizontal grid resolution was determined per FCC KDB Publication 865664 D01v01r04 (See Table 5.1) and IEEE1528-2013.
2. The point SAR measurement was taken at the maximum SAR region determined from Step 1 to enable the monitoring of SAR fluctuations/drifts during the 1g/10g cube evaluation. SAR at this fixed point was measured and used as a reference value.
3. Based on the area scan data, the peak of the region with maximum SAR was determined by spline interpolation. Around this point, a volume was assessed according to the measurement resolution and volume size requirements of FCC KDB Publication 865664 D01v01r04 (See Table 5.1) and IEEE 1528-2013. On the basis of this data set, the spatial peak SAR value was evaluated with the following procedure (see references or the DASY manual online for more details):
 - a. SAR values at the inner surface of the phantom are extrapolated from the measured values along the line away from the surface with spacing no greater than that in Table 5.1. The extrapolation was based on a least-squares algorithm. A polynomial of the fourth order was calculated through the points in the z-axis (normal to the phantom shell).
 - b. After the maximum interpolated values were calculated between the points in the cube, the SAR was averaged over the spatial volume (1g or 10g) using a 3D-Spline interpolation algorithm. The 3D-spline is composed of three one-dimensional splines with the "Not a knot" condition (in x, y, and z directions). The volume was then integrated with the trapezoidal algorithm. One thousand points (10 x 10 x 10) were obtained through interpolation, in order to calculate the averaged SAR.
 - c. All neighboring volumes were evaluated until no neighboring volume with a higher average value was found.
4. The SAR reference value, at the same location as step 2, was re-measured after the zoom scan was complete to calculate the SAR drift. If the drift deviated by more than 5%, the SAR test and drift measurements were repeated.

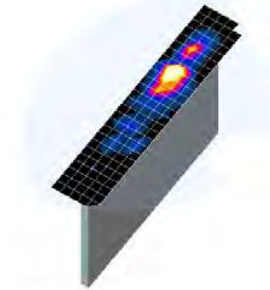

Figure 5.1
Sample SAR Area Scan

		≤ 3 GHz	> 3 GHz
Maximum distance from closest measurement point (geometric center of probe sensors) to phantom surface		$5 \text{ mm} \pm 1 \text{ mm}$	$\frac{1}{2} \cdot \delta \cdot \ln(2) \text{ mm} \pm 0.5 \text{ mm}$
Maximum probe angle from probe axis to phantom surface normal at the measurement location		$30^\circ \pm 1^\circ$	$20^\circ \pm 1^\circ$
Maximum area scan spatial resolution: Δx_{Area} , Δy_{Area}		≤ 2 GHz: $\leq 15 \text{ mm}$ 2 – 3 GHz: $\leq 12 \text{ mm}$	3 – 4 GHz: $\leq 12 \text{ mm}$ 4 – 6 GHz: $\leq 10 \text{ mm}$
		When the x or y dimension of the test device, in the measurement plane orientation, is smaller than the above, the measurement resolution must be \leq the corresponding x or y dimension of the test device with at least one measurement point on the test device.	
Maximum zoom scan spatial resolution: Δx_{Zoom} , Δy_{Zoom}		≤ 2 GHz: $\leq 8 \text{ mm}$ 2 – 3 GHz: $\leq 5 \text{ mm}^*$	3 – 4 GHz: $\leq 5 \text{ mm}^*$ 4 – 6 GHz: $\leq 4 \text{ mm}^*$
Maximum zoom scan spatial resolution, normal to phantom surface	uniform grid: $\Delta z_{Zoom}(n)$	$\leq 5 \text{ mm}$	3 – 4 GHz: $\leq 4 \text{ mm}$ 4 – 5 GHz: $\leq 3 \text{ mm}$ 5 – 6 GHz: $\leq 2 \text{ mm}$
	graded grid	$\Delta z_{Zoom}(1)$: between 1 st two points closest to phantom surface	$\leq 4 \text{ mm}$
		$\Delta z_{Zoom}(n>1)$: between subsequent points	$\leq 1.5 \cdot \Delta z_{Zoom}(n-1) \text{ mm}$
Minimum zoom scan volume	x, y, z	$\geq 30 \text{ mm}$	3 – 4 GHz: $\geq 28 \text{ mm}$ 4 – 5 GHz: $\geq 25 \text{ mm}$ 5 – 6 GHz: $\geq 22 \text{ mm}$
Note: δ is the penetration depth of a plane-wave at normal incidence to the tissue medium; see IEEE Std 1528-2013 for details. * When zoom scan is required and the <i>reported</i> SAR from the <i>area scan based 1-g SAR estimation</i> procedures of KDB Publication 447498 is $\leq 1.4 \text{ W/kg}$, $\leq 8 \text{ mm}$, $\leq 7 \text{ mm}$ and $\leq 5 \text{ mm}$ zoom scan resolution may be applied, respectively, for 2 GHz to 3 GHz, 3 GHz to 4 GHz and 4 GHz to 6 GHz.			

Table 5.1 Area and Zoom Scan Resolutions per FCC KDB Publication 865664 D01v01r04*

6. DEFINITION OF REFERENCE POINTS

6.1 Ear Reference Point

Figure 6.1 shows the front, back and side views of the SAM Twin Phantom. The point “M” is the reference point for the center of the mouth, “LE” is the left ear reference point(ERP), and “RE” is the right ERP. The ERPs are 15mm posterior to the entrance to the Ear canal (EEC) along the B-M line (Back-Mouth), as shown in Figure 6.1. The plane Passing, through the two ear canals and M is defined as the Reference Plane. The line N-F (Neck- Front) is perpendicular to the reference plane and passing through the RE (or LE) is called the Reference Pivoting Line (see Figure 6.1). Line B-M is perpendicular to the N-F line. Both N-F and B-M lines are marked on the external phantom shell to facilitate handset positioning.

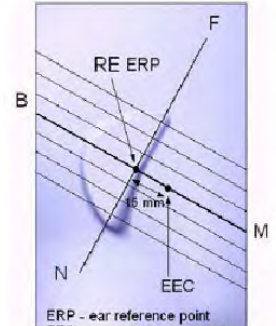

Figure 6.1
Close-up side view of ERP

6.2 Handset Reference Points

Two imaginary lines on the handset were established: the vertical centerline and the horizontal line. The test device was placed in a normal operating position with the “test device reference point” located along the “vertical centerline” on the front of the device aligned to the “ear reference point” (See Fig. 6.3). The “test device reference point” was then located at the same level as the center of the ear reference point. The test device was positioned so that the “vertical centerline” was bisecting the front surface of the handset at it’s top and bottom edges, positioning the “ear reference point” on the outer surface of the both the left and right head phantoms on the ear reference point.



Figure 6.2 Front, back and side view SAM Twin Phantom

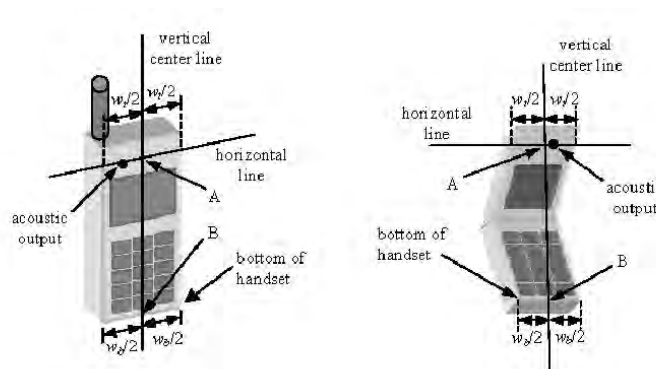

Figure 6.3 Handset Vertical Center & Horizontal Line Reference Points

7. TEST CONFIGURATION POSITIONS FOR HANDSETS

7.1 Device Holder

The device holder is made out of low-loss POM material having the following dielectric parameters: relative permittivity $\epsilon = 3$ and loss tangent $\delta = 0.02$.

7.2 Positioning for Cheek/Touch

1. The test device was positioned with the handset close to the surface of the phantom such that point A is on the (virtual) extension of the line passing through points RE and LE on the phantom (see Figure 7.1), such that the plane defined by the vertical center line and the horizontal line of the phone is approximately parallel to the sagittal plane of the phantom.



Figure 7.1 Front, Side and Top View of Cheek/Touch Position

2. The handset was translated towards the phantom along the line passing through RE & LE until the handset touches the ear.
3. While maintaining the handset in this plane, the handset was rotated around the LE-RE line until the vertical centerline was in the plane normal to MB-NF including the line MB (reference plane).
4. The phone was then rotated around the vertical centerline until the phone (horizontal line) was symmetrical with respect to the line NF.
5. While maintaining the vertical centerline in the reference plane, keeping point A on the line passing through RE and LE, and maintaining the phone contact with the ear, the handset was rotated about the line NF until any point on the handset made contact with a phantom point below the ear (cheek). (See Figure 7.2)

7.3 Positioning for Ear / 15 ° Tilt

With the test device aligned in the “Cheek/Touch Position”:

1. While maintaining the orientation of the phone, the phone was retracted parallel to the reference plane far enough to enable a rotation of the phone by 15 degree.
2. The phone was then rotated around the horizontal line by 15 degree.
3. While maintaining the orientation of the phone, the phone was moved parallel to the reference plane until any part of the phone touches the head. (In this position, point A was located on the line RE-LE). The tilted position is obtained when the contact is on the pinna. If the contact was at any location other than the pinna, the angle of the phone would then be reduced. The tilted position was obtained when any part of the phone was in contact of the ear as well as a second part of the phone was in contact with the head (see Figure 7.3).

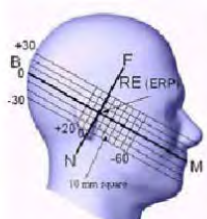

Figure 7.2 Side view w/relevant markings



Figure 7.3 Front, Side and Top View of Ear/15° Position

7.4 Body-Worn Accessory Configurations

Body-worn operating configurations are tested with the belt-clips and holsters attached to the device and positioned against a flat phantom in a normal use configuration (see Figure 7.4). Per FCC KDB Publication 648474 D04v01r03, Body-worn accessory exposure is typically related to voice mode operations when handsets are carried in body-worn accessories. The body-worn accessory procedures in FCC KDB Publication 447498 D01v06 should be used to test for body-worn accessory SAR compliance, without a headset connected to it. This enables the test results for such configuration to be compatible with that required for hotspot mode when the body-worn accessory test separation distance is greater than or equal to that required for hotspot mode, when applicable. When the reported SAR for a body-worn accessory, measured without a headset connected to the handset, is > 1.2 W/kg, the highest reported SAR configuration for that wireless mode and frequency band should be repeated for that body-worn accessory with a headset attached to the handset.

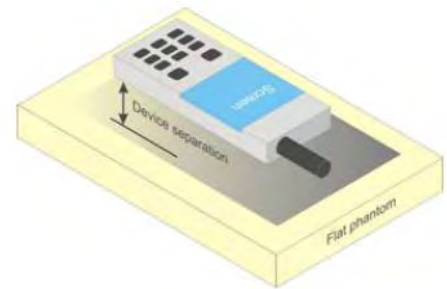

Figure 7.4 Sample Body-Worn Diagram

Accessories for Body-worn operation configurations are divided into two categories: those that do not contain metallic components and those that do contain metallic components. When multiple accessories that do not contain metallic components are supplied with the device, the device is tested with only the accessory that dictates the closest spacing to the body. Then multiple accessories that contain metallic components are tested with the device with each accessory. If multiple accessories share an identical metallic component (i.e. the same metallic belt-clip used with different holsters with no other metallic components) only the accessory that dictates the closest spacing to the body is tested.

Body-worn accessories may not always be supplied or available as options for some devices intended to be authorized for body-worn use. In this case, a test configuration with a separation distance between the back of the device and the flat phantom is used. Test position spacing was documented.

Transmitters that are designed to operate in front of a person's face, as in push-to-talk configurations, are tested for SAR compliance with the front of the device positioned to face the flat phantom in head fluid. For devices that are carried next to the body such as a shoulder, waist or chest-worn transmitters, SAR compliance is tested with the accessories, including headsets and microphones, attached to the device and positioned against a flat phantom in a normal use configuration.

7.5 Extremity Exposure Configurations

Devices that are designed or intended for use on extremities or mainly operated in extremity only exposure conditions; i.e., hands, wrists, feet and ankles, may require extremity SAR evaluation. When the device also operates in close proximity to the user's body, SAR compliance for the body is also required. The 1-g body and 10-g extremity SAR Exclusion Thresholds found in KDB Publication 447498D01v06 should be applied to determine SAR test requirements.

7.6 Wireless Router Configurations

Some battery-operated handsets have the capability to transmit and receive user data through simultaneous transmission of WIFI simultaneously with a separate licensed transmitter. The FCC has provided guidance in FCC KDB Publication 941225 D06v02r01 where SAR test considerations for handsets ($L \times W \geq 9 \text{ cm} \times 5 \text{ cm}$) are based on a composite test separation distance of 10 mm from the front, rear and edges of the device containing transmitting antennas within 2.5 cm of their edges, determined from general mixed use conditions for this type of devices. Since the hotspot SAR results may overlap with the body-worn accessory SAR requirements, the more conservative configurations can be considered, thus excluding some body-worn accessory SAR tests.

When the user enables the personal wireless router functions for the handset, actual operations include simultaneous transmission of both the WIFI transmitter and another licensed transmitter. Both transmitter often do not transmit at the same transmitting frequency and thus cannot be evaluated for SAR under actual use conditions due to the limitations of the SAR assessment probes. Therefore, SAR must be evaluated for each KDB Publication 447498 D01v06 procedures. The "Portable Hotspot" feature on the handset was not activated during SAR assessment, to ensure the SAR measurements were evaluated for a single transmission frequency RF signal at a time.

8. RF EXPOSURE LIMITS

Uncontrolled Environment:

UNCONTROLLED ENVIRONMENTS are defined as locations where there is the exposure of individuals who have no knowledge or control of their exposure. The general population/uncontrolled exposure limits are applicable to situations in which the general public may be exposed or in which persons who are exposed as a consequence of their employment may not be made fully aware of the potential for exposure or cannot exercise control over their exposure. Members of the general public would come under this category when exposure is not employment-related; for example, in the case of a wireless transmitter that exposes persons in its vicinity.

Controlled Environment:

CONTROLLED ENVIRONMENTS are defined as locations where there is exposure that may be incurred by persons who are aware of the potential for exposure, (i.e. as a result of employment or occupation). In general, occupational/controlled exposure limits are employment, who have been made fully aware of the potential for exposure and can exercise control over their exposure. This exposure category is also applicable when the exposure is of a transient nature due to incidental passage through a location where the exposure levels may be higher than the general population/uncontrolled limits, but the exposed person is fully aware of the potential for exposure and can exercise control over his or her exposure by leaving the area or by some other appropriate means.

Table 8.1.SAR Human Exposure Specified in ANSI/IEEE C95.1-1992

	HUMAN EXPOSURE LIMITS	
	General Public Exposure (W/kg) or (mW/g)	Occupational Exposure (W/kg) or (mW/g)
SPATIAL PEAK SAR * (Brain)	1.60	8.00
SPATIAL AVERAGE SAR ** (Whole Body)	0.08	0.40
SPATIAL PEAK SAR *** (Hands / Feet / Ankle / Wrist)	4.00	20.0

1. The Spatial Peak value of the SAR averaged over any 1 gram of tissue (defined as a tissue volume in the shape of a cube) and over the appropriate averaging time.
2. The Spatial Average value of the SAR averaged over the whole body.
3. The Spatial Peak value of the SAR averaged over any 10 grams of tissue (defined as a tissue volume in the shape of a cube) and over the appropriate averaging time.

Uncontrolled Environments are defined as locations where there is the exposure of individuals who have no knowledge or control of their exposure.

Controlled Environments are defined as locations where there is exposure that may be incurred by persons who are aware of the potential for exposure, (i.e.as a result of employment or occupation).

9. FCC MEASUREMENT PROCEDURES

Power measurements were performed using a base station simulator under digital average power.

9.1 Measured and Reported SAR

Per FCC KDB Publication 447498 D01v06, When SAR is not measured at the maximum power level allowed for production units, the results must be scaled to the maximum tune-up tolerance limit according to the power applied to the individual channels tested to determine compliance. For simultaneous transmission, the measured aggregate SAR must be scaled according to the sum of the differences between the maximum tune-up tolerance and actual power used to test each transmitter. When SAR is measured at or scaled to the maximum tune-up tolerance limit, the results are referred to as reported SAR. The highest reported SAR results are identified on the grant of equipment authorization according to procedures in KDB 690783 D01v01r03.

9.2 Procedures Used to Establish RF Signal for SAR

The following procedures are according to FCC KDB Publication 941225 D01v03r01.

The device was placed into a simulated call using a base station simulator in a RF shielded chamber. Establishing connections in this manner ensure a consistent means for testing SAR and are recommended for evaluating SAR [4]. Devices under test were evaluated prior to testing, with a fully charged battery and were configured to operate at maximum output power. In order to verify that the device was tested throughout the SAR test at maximum output power, the SAR measurement system measures a “point SAR” at an arbitrary reference point at the start and end of the 1 gram SAR evaluation, to assess for any power drifts during the evaluation. If the power drift deviated by more than 5%, the SAR test and drift measurements were repeated.

9.3 SAR Measurement Conditions for WCDMA (UMTS)

9.3.1 Output Power Verification

Maximum output power is measured on the High, Middle and Low channels for each applicable transmission band according to the general descriptions in section 5.2 of 3GPP TS 34.121, using the appropriate RMC or AMR with TPC (transmit power control) set to all “1s”.

Maximum output power is verified on the High, Middle and Low channels according to the general, descriptions in section 5.2 of 3GPP TS 34.121 (release 5), using the appropriate RMC with TPC,(transmit power control) set to all “1s” or applying the required inner loop power control procedures to maintain maximum output power while HSUPA is active. Results for all applicable physical channel configurations (DPCCH, DPDCHn and spreading codes, HS-DPCCH etc) are tabulated in this test report. All configurations that are not supported by the DUT or cannot be measured due to technical or equipment limitations are identified.

9.3.2 Head SAR Measurements for Handsets

SAR for head exposure configurations is measured using the 12.2 kbps RMC with TPC bits configured to all “1s”. SAR in AMR configurations is not required when the maximum average output of each RF channel for 12.2 kbps AMR is less than 0.25 dB higher than that measured in 12.2 kbps RMC. Otherwise, SAR is measured on the maximum output channel in 12.2 AMR with a 3.4 kbps SRB (signaling radio bearer) using the exposure configuration that resulted in the highest SAR for that RF channel in the 12.2 kbps RMC mode.

9.3.3 Body SAR Measurements

SAR for body exposure configurations is measured using the 12.2 kbps RMC with the TPC bits all "1s".

9.3.4 Release 5 HSDPA Data Devices

The following procedures are applicable to HSDPA data devices operating under 3GPP Release 5. SAR is required for devices in body-worn accessory and other body exposure conditions, including handsets and data modems operating in various electronic devices. HSDPA operates in conjunction with WCDMA and requires an active DPCCH. The default test configuration is to measure SAR in WCDMA with HSDPA remain inactive, to establish a radio link between the test device and a communication test set using a 12.2 kbps RMC configured in Test Loop Mode 1. SAR for HSDPA is selectively measured using the highest reported SAR configuration in WCDMA, with an FRC in H-set 1 and a 12.2 kbps RMC. SAR is selectively confirmed for other physical channel configurations (DPCCH & DPDCHn) according to exposure conditions, device operating capabilities and maximum output power specified for production units, including tune-up tolerance by applying the 3G SAR test reduction procedures. Maximum output power is verified according to the applicable versions of 3GPP TS 34.121. SAR must be measured based on these maximum output conditions and requirements in KDB Publication 447498, with respect to the UE Categories, and explained in the SAR report. When Maximum Power Reduction (MPR) applies, the implementations must be clearly identified in the SAR report to support test results according to Cubic Metric (CM) and, as appropriate, Enhanced MPR (E-MPR) requirements.

Sub-test	β_c	β_d	β_d (SF)	β_c/β_d	$\beta_{hs}^{(1)}$	CM (dB) ⁽²⁾
1	2/15	15/15	64	2/15	4/15	0.0
2	12/15 ⁽³⁾	15/15 ⁽³⁾	64	12/15 ⁽³⁾	24/15	1.0
3	15/15	8/15	64	15/8	30/15	1.5
4	15/15	4/15	64	15/4	30/15	1.5

Note 1: Δ_{ACK} , Δ_{NACK} and $\Delta_{CQI} = 8 \Leftrightarrow A_{hs} = \beta_{hs}/\beta_c = 30/15 \Leftrightarrow \beta_{hs} = 30/15 * \beta_c$
 Note 2: CM = 1 for $\beta_c/\beta_d = 12/15$, $\beta_{hs}/\beta_c = 24/15$.
 Note 3: For subtest 2 the β_c/β_d ratio of 12/15 for the TFC during the measurement period (TF1, TF0) is achieved by setting the signaled gain factors for the reference TFC (TF1, TF1) to $\beta_c = 11/15$ and $\beta_d = 15/15$.

Figure 9.1 Table 1

9.3.5 Release 6 HSUPA Data Devices

The following procedures are applicable to HSPA (HSUPA/HSDPA) data devices operating under 3GPP Release 6. SAR is required for devices in body-worn accessory and other body exposure conditions, including handsets and data modems operating in various electronic devices. HSUPA operates in conjunction with WCDMA and HSDPA. SAR is initially measured in WCDMA test configurations with HSPA remain inactive. The default test configuration is to establish a radio link between the test device and a communication test set to configure a 12.2 kbps RMC in Test Loop Mode 1. SAR for HSPA is selectively measured with HS-DPCCH, E-DPCCH and E-DPDCH, all enabled, along with a 12.2 kbps RMC using the highest reported SAR configuration in WCDMA with 12.2 kbps RMC only.

An FRC is configured according to HS-DPCCH Sub-test 1 using H-set 1 and QPSK. HSPA is configured according to E-DCH Sub-test 5 requirements. SAR for other HSPA sub-test configurations is confirmed selectively according to exposure conditions, E-DCH UE Category and maximum output power of production units, including tune-up tolerance by applying the 3G SAR test reduction procedure. Maximum output power is verified according to procedures in applicable versions of 3GPP TS 34.121. SAR must be measured based on these maximum output conditions and requirements in KDB Publication 447498, with respect to the UE Categories for HS-DPCCH and HSPA, and explained in the SAR report. When Maximum Power Reduction (MPR) applies, the implementations must be clearly identified in the SAR report to support test results according to Cubic Metric (CM) and, as appropriate, Enhanced MPR (E-MPR) requirements.

Sub-test	β_c	β_d	β_a (SF)	β_e/β_d	$\beta_{hs}^{(1)}$	β_{ec}	β_{ed}	β_{ed} (SF)	β_{ed} (codes)	CM ⁽²⁾ (dB)	MPR (dB)	AG ⁽⁴⁾ Index	E-TFCI
1	11/15 ⁽³⁾	15/15 ⁽³⁾	64	11/15 ⁽³⁾	22/15	209/225	1039/225	4	1	1.0	0.0	20	75
2	6/15	15/15	64	6/15	12/15	12/15	94/75	4	1	3.0	2.0	12	67
3	15/15	9/15	64	15/9	30/15	30/15	$\beta_{ed}: 47/15$ $\beta_{ed}: 47/15$	4	2	2.0	1.0	15	92
4	2/15	15/15	64	2/15	4/15	2/15	56/75	4	1	3.0	2.0	17	71
5	15/15 ⁽⁴⁾	15/15 ⁽⁴⁾	64	15/15 ⁽⁴⁾	30/15	24/15	134/15	4	1	1.0	0.0	21	81

Note 1: Δ_{ACK} , Δ_{NACK} and $\Delta_{CQI} = 8 \Leftrightarrow A_{hs} = \beta_{hs}/\beta_c = 30/15 \Leftrightarrow \beta_{hs} = 30/15 * \beta_c$.
 Note 2: CM = 1 for $\beta_c/\beta_d = 12/15$, $\beta_{hs}/\beta_c = 24/15$. For all other combinations of DPDCH, DPCCCH, HS-DPCCH, E-DPDCH and E-DPCCH the MPR is based on the relative CM difference.
 Note 3: For subtest 1 the β_c/β_d ratio of 11/15 for the TFC during the measurement period (TF1, TF0) is achieved by setting the signaled gain factors for the reference TFC (TF1, TF1) to $\beta_c = 10/15$ and $\beta_d = 15/15$.
 Note 4: For subtest 5 the β_c/β_d ratio of 15/15 for the TFC during the measurement period (TF1, TF0) is achieved by setting the signaled gain factors for the reference TFC (TF1, TF1) to $\beta_c = 14/15$ and $\beta_d = 15/15$.
 Note 5: Testing UE using E-DPDCH Physical Layer category 1 Sub-test 3 is not required according to TS 25.306 Table 5.1g.
 Note 6: β_{ed} cannot be set directly; it is set by Absolute Grant Value.

Figure 9.2 Table 2

9.4 SAR Measurement Conditions for LTE

LTE modes were tested according to FCC KDB 941225 D05v02r05 publication. Please see notes after the tabulated SAR data for required test configurations. Establishing connections with base station simulators ensure a consistent means for testing SAR and are recommended for evaluating SAR. The R&S CMW500 was used for LTE output power measurement and SAR testing. Closed loop power control was used so the UE transmits with maximum output power during SAR testing. SAR tests were performed with the same number of RB and RB offsets transmitting on all TTI frames (maximum TTI).

9.4.1 Spectrum Plots for RB Configurations

A properly configured base station simulator was used for SAR tests and power measurements. Therefore, spectrum plots for RB configurations were not required to be included in this report.

9.4.2 MPR

MPR is permanently implemented for this device by the manufacturer. The specific manufacturer target MPR is indicated alongside the SAR results. MPR is enabled for this device, according to 3GPP TS36. 101 Section 6.2.3 – 6.2.5 under Table 6.2.3-1.

9.4.3 A-MPR

A-MPR (Addition MPR) has been disabled for all SAR tests by setting NS=01 on the base station simulator.

9.4.4 Required RB Size and RB Offsets for SAR Testing

According to FCC KDB 941225 D05v02r05:

- a. Per Section 4.2.1, SAR is required for QPSK 1 RB Allocation for the largest bandwidth
 - i. The required channel and offset combination with the highest maximum output power is required for SAR.
 - ii. When the reported SAR is ≤ 0.8 W/kg, testing of the remaining RB offset configurations and required test channel is not required. Otherwise, SAR is required for the remaining required test channels using the RB offset configuration with highest output power for that channel.
 - iii. When the reported SAR for a required test channel is > 1.45 W/kg, SAR is required for all RB offset configurations for that channel.
- b. Per Section 4.2.2, SAR is required for 50% RB allocation using the largest bandwidth following the same procedures outlined in Section 4.2.1.
- c. Per Section 4.2.3, QPSK SAR is not required for the 100% allocation when the highest maximum output power for the 100% allocation is less than the highest maximum output power of the 1 RB and 50% RB allocations and the reported SAR for the 1 RB and 50% RB allocations is < 0.8 W/kg.
- d. Per Section 4.2.4 and 4.3, SAR tests for higher order modulations and lower bandwidths configurations are not required when the conducted power of the required test configurations determined by Sections 4.2.1 through 4.2.3 is less than or equal to 0.5 dB higher than the equivalent configuration using QPSK modulation and when the QPSK SAR for those configurations is < 1.45 W/kg.

9.5 SAR Testing with 802.11 Transmitters

The normal network operating configurations are not suitable for measuring the SAR of 802.11 b/g/n transmitters. Unpredictable fluctuations in network traffic and antenna diversity conditions can introduce undesirable variations in SAR results. The SAR for these devices should be measured using chipset based test mode software to ensure the results are consistent and reliable. See KDB Publication 248227D01v02r02 for more details.

9.5.1 General Device Setup

Chipset based test mode software is hardware dependent and generally varies among manufacturers. The device operating parameters established in test mode for SAR measurements must be identical to those programmed in production units, including output power levels, amplifier gain settings and other RF performance tuning parameters. The test frequencies should correspond to actual channel frequencies defined for domestic use. SAR for devices with switched diversity should be measured with only one antenna transmitting at a time during each SAR measurement, according to a fixed modulation and data rate. The same data pattern should be used for all measurements.

A periodic duty factor is required for current generation SAR systems to measure SAR. When 802.11 frame gaps are accounted for in the transmission, a maximum transmission duty factor of 92-96% is typically achievable in most test mode configurations. A minimum transmission duty factor of 85% is required to avoid certain hardware and device implementation issues related to wide range SAR scaling. The reported SAR is scaled to 100% transmission duty factor to determine compliance at the maximum tune-up tolerance limit.

9.5.2 U-NII and U-NII-2A

For devices that operate in only one of the U-NII-1 and U-NII-2A bands, the normally required SAR procedures for OFDM configurations are applied. For devices that operate in both U-NII bands using the same transmitter and antenna(s), SAR test reduction is determined according to the following, with respect to the highest reported SAR and maximum output power specified for production units. The procedures are applied independently to each exposure configuration; for example, head, body, hotspot mode etc.

- 1) When the same maximum output power is specified for both bands, begin SAR measurement in U-NII-2A band by applying the OFDM SAR requirements. If the highest reported SAR for a test configuration is ≤ 1.2 W/kg, SAR is not required for U-NII-1 band for that configuration (802.11 mode and exposure condition); otherwise, each band is tested independently for SAR.
- 2) When different maximum output power is specified for the bands, begin SAR measurement in the band with higher specified maximum output power. The highest reported SAR for the tested configuration is adjusted by the ratio of lower to higher specified maximum output power for the two bands. When the adjusted SAR is ≤ 1.2 W/kg, SAR is not required for the band with lower maximum output power in that test configuration; otherwise, each band is tested independently for SAR.

9.5.3 U-NII-2C and U-NII-3

The frequency range covered by U-NII-2C and U-NII-3 is 380 MHz (5.47 – 5.85 GHz), which requires a minimum of at least two SAR probe calibration frequency points to support SAR measurements.

When Terminal Doppler Weather Rader (TDWR) restriction applies, the channels at 5.60 – 5.65 GHz in U-NII-2C band must be disabled with acceptable mechanisms and documented in the equipment certification.

Unless band gap channels are permanently disabled, SAR must be considered for these channels. When band gap channels are disabled, each band is tested independently according to the normally required OFDM SAR measurements and probe calibration frequency points requirements.

9.5.4 Initial Test Position Procedure

For exposure conditions with multiple test positions, such as handset operating next to the ear, devices with hotspot mode or UMPC mini-tablet, procedures for initial test position can be applied. Using the transmission mode determined by the DSSS procedure or initial test configuration, area scans are measured for all position in an exposure condition. The test position with the highest extrapolated (peak) SAR is used as the initial test position. When reported SAR for the initial test position is ≤ 0.4 W/kg, no additional testing for the remaining test positions is required. Otherwise, SAR is evaluated at the subsequent highest peak SAR position until the reported SAR result is ≤ 0.8 W/kg or all test position are measured.

9.5.5 2.4 GHz SAR Test Requirements

SAR is measured for 2.4 GHz 802.11b DSSS using either a fixed test position or, when applicable, the initial test position procedure. SAR test reduction is determined according to the following:

- 1) When the reported SAR of the highest measured maximum output power channel for the exposure configuration is ≤ 0.8 W/kg, no further SAR testing is required for 802.11b DSSS in that exposure configuration.
- 2) When the reported SAR is > 0.8 W/kg, SAR is required for that exposure configuration using the next highest measured output power channel. When any reported SAR is > 1.2 W/kg, SAR is required for the third channel; i.e., all channels require testing.

2.4 GHz 802.11 g/n OFDM are additionally evaluated for SAR if the highest reported SAR for 802.11b, adjusted by the ratio of the OFDM to DSSS specified maximum output power is > 1.2 W/kg. When SAR is required for OFDM modes in 2.4 GHz band, the Initial Test Configuration Procedures should be followed.

9.5.6 OFDM Transmission Mode and SAR Test Channel Selection

For the 2.4 GHz and 5 GHz bands, when the same maximum output power was specified for multiple OFDM transmission mode configurations in a frequency band or aggregated band, SAR is measured using the configuration with the largest channel bandwidth, lowest order modulation and lowest data rate. When the maximum output power of a channel is the same for equivalent OFDM configurations; for example, 802.11a and 802.11n or 802.11g and 802.11n with the same channel bandwidth, modulation and data rate etc., the lower order 802.11 mode i.e., 802.11a, then 802.11g then 802.11n is used for SAR measurement. When the maximum output power were the same for multiple test channels, either according to the default or additional power measurement requirements, SAR is measured using the channel closest to the middle of the frequency band or aggregated band. When there are multiple channels with the same maximum output power, SAR is measured using the higher number channel.

9.5.7 Initial Test Configuration Procedure

For OFDM, in both 2.4 and 5 GHz bands, an initial test configuration is determined for each frequency band and aggregated band, according to the transmission mode with the highest maximum output power specified for SAR measurements. When the same maximum output is specified for multiple OFDM transmission mode configurations in a frequency band or aggregated band, SAR is measured using the configuration(s) with the largest channel bandwidth, lowest order modulation, and lowest data rate. The channel of the transmission mode with the highest average RF output conducted power will be the initial test configuration.

When the reported SAR is ≤ 0.8 W/kg, no additional measurements on other test channels are required.

Otherwise, SAR is evaluated using the subsequent highest average RF output channel until the reported SAR result is ≤ 1.2 W/kg or all channels are measured.

9.5.8 Subsequent Test Configuration Procedures

For OFDM configurations, in each frequency band and aggregated band, SAR is evaluated for initial test configuration using the fixed test position or the initial test position procedure, when applicable. When the highest reported SAR for the initial test configuration, adjusted by the ratio of the subsequent test configuration to initial test configuration specified maximum output power is ≤ 1.2 W/kg, no additional SAR testing for the subsequent test configurations is required.

9.5.9 MIMO SAR Considerations

Per KDB Publication 248227 D01v02r02, the simultaneous SAR provisions in KDB Publication 447498 D01v06 should be applied to determine simultaneous transmission SAR test exclusion for WIFI MIMO. If the sum of 1g single transmission chain SAR measurements is < 1.6 W/kg, no additional SAR measurements for MIMO are required. Alternatively, SAR for MIMO can be measured with all antennas transmitting simultaneously at the specified maximum output power of MIMO operation.

10. RF CONDUCTED POWERS

10.1 GSM Conducted Powers

Band	Channel	Maximum Burst-Averaged Output Power(dBm)								
		Voice	GPRS/EDGE Data (GMSK)				EDGE Data (8-PSK)			
		GSM CS 1 Slot	GPRS 1 TX Slot	GPRS 2 TX Slot	GPRS 3 TX Slot	GPRS 4 TX Slot	EDGE 1 TX Slot	EDGE 2 TX Slot	EDGE 3 TX Slot	EDGE 4 TX Slot
GSM850	128	33.4	33.4	31.4	29.6	27.4	25.6	25.5	24.4	23.6
	190	33.4	33.4	31.4	29.5	27.5	25.6	25.5	24.4	23.6
	251	33.5	33.5	31.3	29.4	27.4	25.6	25.5	24.4	23.6
PCS 1900	512	31.3	31.3	29.4	27.6	25.6	25.3	25.3	24.7	23.7
	661	31.1	31.1	29.4	27.5	25.4	25.2	25.1	24.6	23.7
	810	31.2	31.2	29.4	27.5	25.4	25.2	25.1	24.6	23.7
Band	Channel	Calculated Maximum Frame-Averaged Output Power(dBm)								
		Voice	GPRS/EDGE Data (GMSK)				EDGE Data (8-PSK)			
		GSM CS 1 Slot	GPRS 1 TX Slot	GPRS 2 TX Slot	GPRS 3 TX Slot	GPRS 4 TX Slot	EDGE 1 TX Slot	EDGE 2 TX Slot	EDGE 3 TX Slot	EDGE 4 TX Slot
GSM850	128	24.37	24.37	25.38	25.34	24.39	16.57	19.48	20.14	20.59
	190	24.37	24.37	25.38	25.24	24.49	16.57	19.48	20.14	20.59
	251	24.47	24.47	25.28	25.14	24.39	16.57	19.48	20.14	20.59
PCS 1900	512	22.27	22.27	23.38	23.34	22.59	16.27	19.28	20.44	20.69
	661	22.07	22.07	23.38	23.24	22.39	16.17	19.08	20.34	20.69
	810	22.17	22.17	23.38	23.24	22.39	16.17	19.08	20.34	20.69
GSM850	Frame Avg. Targets:	24.17	24.17	25.18	24.94	24.19	16.17	19.18	19.94	20.19
PCS 1900		22.17	22.17	23.18	22.94	22.19	16.17	19.18	19.94	20.19

Table 10.1 GSM Conducted Power

Note:

- Both burst-averaged and calculated frame-averaged powers are included. Frame-averaged power was calculated from the measured burst-averaged power by converting the slot powers into linear units and calculating the energy over 8 timeslots.
- GPRS (GMSK) output powers were measured with coding scheme setting of 1 (CS1) on the base station simulator. CS1 was configured to measure GPRS output power measurements and SAR to ensure GMSK modulation in the signal. Our Investigation has shown that CS1 - CS4 settings do not have any impact on the output levels or modulation in the GPRS modes.
- EDGE (8-PSK) output powers were measured with MCS7 on the base station simulator. MCS7 coding scheme was used to measure the output powers for EDGE since investigation has shown that choosing MCS7 coding scheme will ensure 8-PSK modulation. It has been shown that MCS levels that produce 8PSK modulation do not have an impact on output power.

GPRS Multislot class: 12 (max 4 TX Uplink slots)
 EDGE Multislot class: 12 (max 4 TX Uplink slots)
 DTM Multislot Class: N/A



Figure 10.1 Power Measurement Setup

10.2 WCDMA Conducted Powers

3GPP Release Version	Mode	3GPP 34.121 Subtest	Cellular Band (dBm)			AWS Band (dBm)			PCS Band (dBm)			3GPP MPR (dB)
			4132	4183	4233	1312	1412	1513	9262	9400	9538	
99	WCDMA	12.2 kbps RMC	24.98	24.87	24.91	22.63	22.68	22.50	22.66	22.66	22.69	-
99		12.2 kbps AMR	24.97	24.86	24.91	22.63	22.68	22.48	22.66	22.66	22.68	-
5	HSDPA	Subtest 1	23.99	23.88	23.93	21.63	21.68	21.49	21.64	21.66	21.74	0
5		Subtest 2	24.03	23.92	23.95	21.65	21.70	21.50	21.67	21.68	21.78	0
5		Subtest 3	23.53	23.41	23.49	21.14	21.20	21.01	21.19	21.19	21.27	0.5
5		Subtest 4	23.52	23.41	23.47	21.16	21.19	21.00	21.19	21.20	21.28	0.5
6	HSUPA	Subtest 1	23.98	23.87	23.94	21.63	21.68	21.48	21.67	21.65	21.73	0
6		Subtest 2	22.01	21.90	21.96	19.67	19.70	19.50	19.69	19.67	19.77	2
6		Subtest 3	23.01	22.92	22.96	20.65	20.70	20.50	20.68	20.68	20.76	1
6		Subtest 4	22.03	21.93	21.95	19.64	19.70	19.50	19.65	19.67	19.76	2
6		Subtest 5	23.99	23.91	23.94	21.64	21.69	21.48	21.66	21.67	21.75	0

Table 10.2.1 WCDMA Conducted Power

WCDMA SAR was tested under RMC 12.2 kbps with HSPA Inactive per KDB Publication 941225 D01v03r01. HSPA SAR was not required since the average output power of the HSPA subtests was not more than 0.25 dB higher than the RMC level and SAR was less than 1.2 W/kg.

The manufacturer declares that the HSDPA and HSUPA transmitter's power will not exceed the R99 maximum transmit power in devices based on Qualcomm's HSPA chipset solutions.

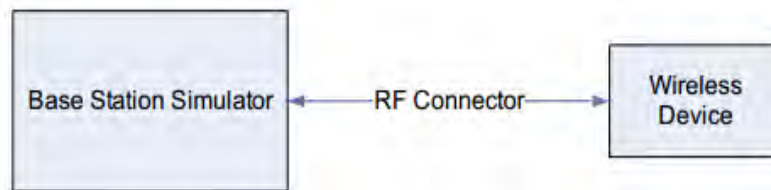

Figure 10.2 Power Measurement Setup

10.3 LTE Conducted Powers

1) LTE Band 17

LTE Band 17 Conducted Power– 10 MHz Bandwidth					
Modulation	RB Size	RB Offset	Mid Channel	MPR Allowed Per 3GPP(dB)	MPR (dB)
			23790 (710.0 MHz)		
			Conducted Power (dBm)		
QPSK	1	0	24.86	0	0
	1	25	24.92		
	1	49	24.85		
	25	0	23.89	0-1	1
	25	12	23.85		
	25	25	23.85		
	50	0	23.89	0-1	1
16QAM	1	0	24.19	0-1	1
	1	25	24.13		
	1	49	24.02		
	25	0	22.72	0-2	2
	25	12	22.72		
	25	25	22.70		
	50	0	22.69	0-2	2
64QAM	1	0	23.11	0-2	2
	1	25	23.07		
	1	49	22.96		
	25	0	21.81	0-3	3
	25	12	21.82		
	25	25	21.76		
	50	0	21.82	0-3	3

Table 10.3.1 LTE Conducted Power

Note 1: LTE Band 17 at 10 MHz bandwidth does not support three non-overlapping channels.

Per KDB 941225 D05v02r05, when a device supports overlapping channel assignment in a channel bandwidth configuration, the middle channel of the group of overlapping channels should be selected for testing.

Note 2: The applicant declared that MPR transmission power will not exceed the non MPR maximum transmit power in devices and this device is applied MPR based on 3GPP standard.

LTE Band 17 Conducted Power– 5 MHz Bandwidth						
Modulation	RB Size	RB Offset	Mid Channel	MPR Allowed Per 3GPP(dB)	MPR (dB)	
			23790 (710.0 MHz)			
			Conducted Power (dBm)			
QPSK	1	0	24.77	0	0	
	1	12	24.91			
	1	24	24.69			
	16QAM	12	0	23.72	0-1	1
		12	6	23.85		
		12	13	23.87		
		25	0	23.83	0-1	1
64QAM	1	0	24.04	0-1	1	
	1	12	24.17			
	1	24	24.02			
	16QAM	12	0	22.64	0-2	2
		12	6	22.73		
		12	13	22.66		
		25	0	22.72	0-2	2
64QAM	1	0	22.93	0-2	2	
	1	12	23.06			
	1	24	22.90			
	16QAM	12	0	21.73	0-3	3
		12	6	21.88		
		12	13	21.81		
		25	0	21.76	0-3	3

Table 10.3.2 LTE Conducted Power

Note 1: LTE Band 17 at 5 MHz bandwidth does not support three non-overlapping channels.
Per KDB 941225 D05v02r05, when a device supports overlapping channel assignment in a channel bandwidth configuration, the middle channel of the group of overlapping channels should be selected for testing.

Note 2: The applicant declared that MPR transmission power will not exceed the non MPR maximum transmit power in devices and this device is applied MPR based on 3GPP standard.

2) LTE Band 13

LTE Band 13 Conducted Power– 10 MHz Bandwidth					
Modulation	RB Size	RB Offset	Mid Channel	MPR Allowed Per 3GPP(dB)	MPR (dB)
			23230 (782.0 MHz)		
			Conducted Power (dBm)		
QPSK	1	0	23.65	0	0
	1	25	23.76		
	1	49	23.73		
	25	0	21.97	0-1	1
	25	12	21.98		
	25	25	22.02		
	50	0	21.99	0-1	1
16QAM	1	0	22.50	0-1	1
	1	25	22.56		
	1	49	22.47		
	25	0	21.01	0-2	2
	25	12	21.02		
	25	25	21.05		
	50	0	21.00	0-2	2
64QAM	1	0	21.19	0-2	2
	1	25	21.29		
	1	49	21.26		
	25	0	19.91	0-3	3
	25	12	19.95		
	25	25	19.93		
	50	0	19.88	0-3	3

Table 10.3.3 LTE Conducted Power

Note 1: The applicant declared that MPR transmission power will not exceed the non MPR maximum transmit power in devices and this device is applied MPR based on 3GPP standard.

LTE Band 13 Conducted Power– 5 MHz Bandwidth						
Modulation	RB Size	RB Offset	Mid Channel	MPR Allowed Per 3GPP(dB)	MPR (dB)	
			23230 (782.0 MHz)			
			Conducted Power (dBm)			
QPSK	1	0	23.62	0	0	
	1	12	23.74			
	1	24	23.71			
	16QAM	12	0	21.94	0-1	1
		12	6	21.97		
		12	13	22.01		
		25	0	21.98		
64QAM	1	0	22.48	0-1	1	
	1	12	22.55			
	1	24	22.46			
	16QAM	12	0	21.01	0-2	2
		12	6	21.01		
		12	13	21.02		
		25	0	21.02		
64QAM	1	0	21.17	0-2	2	
	1	12	21.27			
	1	24	21.25			
	16QAM	12	0	19.92	0-3	3
		12	6	19.92		
		12	13	19.91		
		15	0	19.87		

Table 10.3.4 LTE Conducted Power

Note 1: LTE Band 13 at 5 MHz bandwidth does not support three non-overlapping channels.

Per KDB 941225 D05v02r05, when a device supports overlapping channel assignment in a channel bandwidth configuration, the middle channel of the group of overlapping channels should be selected for testing.

Note 2: The applicant declared that MPR transmission power will not exceed the non MPR maximum transmit power in devices and this device is applied MPR based on 3GPP standard.

3) LTE Band 5 (Cell)

LTE Band 5 (Cell) Conducted Power– 10 MHz Bandwidth					
Modulation	RB Size	RB Offset	Mid Channel	MPR Allowed Per 3GPP(dB)	MPR (dB)
			20525 (836.5 MHz)		
			Conducted Power (dBm)		
QPSK	1	0	24.80	0	0
	1	25	24.83		
	1	49	24.91		
	25	0	23.72	0-1	1
	25	12	23.80		
	25	25	23.76		
		50	0	23.78	0-1
16QAM	1	0	24.14	0-1	1
	1	25	24.11		
	1	49	24.06		
	25	0	22.70	0-2	2
	25	12	22.82		
	25	25	22.74		
		50	0	22.81	0-2
64QAM	1	0	22.91	0-2	2
	1	25	22.93		
	1	49	22.90		
	25	0	21.63	0-3	3
	25	12	21.73		
	25	25	21.65		
		50	0	21.69	0-3

Table 10.3.5 LTE Conducted Power

Note 1: LTE Band 5(Cell) at 10 MHz bandwidth does not support three non-overlapping channels.

Per KDB 941225 D05v02r05, when a device supports overlapping channel assignment in a channel bandwidth configuration, the middle channel of the group of overlapping channels should be selected for testing.

Note 2: The applicant declared that MPR transmission power will not exceed the non MPR maximum transmit power in devices and this device is applied MPR based on 3GPP standard.

LTE Band 5 (Cell) Conducted Power– 5 MHz Bandwidth								
Modulation	RB Size	RB Offset	Low Channel	Mid Channel	High Channel	MPR Allowed Per 3GPP(dB)	MPR (dB)	
			20425 (826.5 MHz)	20525 (836.5 MHz)	20625 (846.5 MHz)			
			Conducted Power (dBm)					
QPSK	1	0	24.69	24.75	24.70	0	0	
	1	12	24.77	24.84	24.81			
	1	24	24.60	24.91	24.64			
	QPSK	12	0	23.64	23.83	23.62	0-1	1
		12	6	23.74	23.83	23.63		
		12	13	23.73	23.77	23.60		
		25	0	23.60	23.79	23.60	0-1	1
16QAM	1	0	23.94	24.11	24.10	0-1	1	
	1	12	24.16	24.16	24.06			
	1	24	23.99	24.12	23.98			
	16QAM	12	0	22.67	22.79	22.60	0-2	2
		12	6	22.74	22.80	22.63		
		12	13	22.67	22.76	22.58		
		25	0	22.62	22.78	22.63	0-2	2
64QAM	1	0	22.83	22.89	22.85	0-2	2	
	1	12	22.94	23.03	22.85			
	1	24	22.75	22.90	22.67			
	64QAM	12	0	21.59	21.79	21.60	0-3	3
		12	6	21.74	21.79	21.60		
		12	13	21.69	21.73	21.56		
		25	0	21.50	21.67	21.52	0-3	3

Table 10.3.6 LTE Conducted Power

LTE Band 5 (Cell) Conducted Power– 3 MHz Bandwidth							
Modulation	RB Size	RB Offset	Low Channel	Mid Channel	High Channel	MPR Allowed Per 3GPP(dB)	MPR (dB)
			20415 (825.5 MHz)	20525 (836.5 MHz)	20635 (847.5 MHz)		
			Conducted Power (dBm)				
QPSK	1	0	24.75	24.85	24.66	0	0
	1	7	24.79	24.79	24.61		
	1	14	24.71	24.75	24.55		
	8	0	23.65	23.81	23.62	0-1	1
	8	4	23.66	23.82	23.58		
	8	7	23.65	23.78	23.61		
	15	0	23.63	23.80	23.60	0-1	1
16QAM	1	0	24.02	24.19	24.03	0-1	1
	1	7	23.96	24.18	23.97		
	1	14	24.05	24.18	23.90		
	8	0	22.67	22.84	22.64	0-2	2
	8	4	22.70	22.89	22.68		
	8	7	22.66	22.80	22.62		
	15	0	22.68	22.86	22.67	0-2	2
64QAM	1	0	22.79	22.93	22.74	0-2	2
	1	7	22.70	22.95	22.72		
	1	14	22.98	22.86	22.68		
	8	0	21.62	21.80	21.57	0-3	3
	8	4	21.62	21.76	21.65		
	8	7	21.58	21.75	21.57		
	15	0	21.58	21.72	21.56	0-3	3

Table 10.3.7 LTE Conducted Power

LTE Band 5 (Cell) Conducted Power– 1.4 MHz Bandwidth								
Modulation	RB Size	RB Offset	Low Channel	Mid Channel	High Channel	MPR Allowed Per 3GPP(dB)	MPR (dB)	
			20407 (824.7 MHz)	20525 (836.5 MHz)	20643 (848.3 MHz)			
			Conducted Power (dBm)					
QPSK	1	0	24.68	24.61	24.57	0	0	
	1	2	24.84	24.69	24.58			
	1	5	24.62	24.59	24.52			
	QPSK	3	0	24.67	24.66	24.56	0	0
		3	2	24.69	24.67	24.57		
		3	3	24.65	24.62	24.54		
		6	0	23.66	23.63	23.51		
16QAM	1	0	24.10	24.09	23.91	0-1	1	
	1	2	24.07	24.16	23.94			
	1	5	24.08	24.12	23.89			
	16QAM	3	0	23.71	23.74	23.52	0-1	1
		3	2	23.75	23.76	23.58		
		3	3	23.68	23.72	23.46		
		6	0	22.76	22.82	22.62		
64QAM	1	0	22.80	22.86	22.72	0-2	2	
	1	2	22.86	22.87	22.68			
	1	5	22.81	22.81	22.60			
	64QAM	3	0	22.70	22.79	22.65	0-2	2
		3	2	22.79	22.86	22.59		
		3	3	22.72	22.75	22.57		
		6	0	21.66	21.70	21.43		

Table 10.3.8 LTE Conducted Power

10.4 WLAN Conducted Powers

Mode	Freq.	Channel	IEEE 802.11 (2.4 GHz) Conducted Power
	(MHz)		(dBm)
802.11b	2412	1	15.57
	2437	6	15.69
	2462	11	15.67
802.11g	2412	1	12.58
	2437	6	15.25
	2462	11	12.60
802.11n (HT-20)	2412	1	11.42
	2437	6	14.07
	2462	11	11.45
802.11ac (VHT-20)	2412	1	11.42
	2437	6	14.06
	2462	11	11.44

Table 10.4.1 IEEE 802.11 Average RF Power (Ant.1)

Mode	Freq.	Channel	IEEE 802.11 (2.4 GHz) Conducted Power
	(MHz)		(dBm)
802.11b	2412	1	15.74
	2437	6	15.55
	2462	11	15.50
802.11g	2412	1	12.21
	2437	6	15.01
	2462	11	12.44
802.11n (HT-20)	2412	1	11.12
	2437	6	13.97
	2462	11	11.18
802.11ac (VHT-20)	2412	1	11.14
	2437	6	14.16
	2462	11	11.21

Table 10.4.2 IEEE 802.11 Average RF Power (Ant.2)

Mode	Freq.	Channel	IEEE 802.11 (2.4 GHz) Conducted Power	
	(MHz)		CDD(dBm)	SDM(dBm)
802.11b	2412	1	<u>18.67</u>	-
	2437	6	<u>18.63</u>	-
	2462	11	18.60	-
802.11g	2412	1	15.41	-
	2437	6	18.14	-
	2462	11	15.53	-
802.11n (HT-20)	2412	1	14.28	14.27
	2437	6	17.03	17.01
	2462	11	14.33	14.31
802.11ac (VHT-20)	2412	1	14.29	14.24
	2437	6	17.12	17.02
	2462	11	14.34	14.29

Table 10.4.3 IEEE 802.11 Average RF Power (MIMO)

Mode	Freq.	Channel	IEEE 802.11a (5 GHz) Conducted Power
	(MHz)		(dBm)
802.11a	5180	36	15.47
	5200	40	15.52
	5220	44	15.45
	5240	48	15.65
	5260	52	15.67
	5280	56	15.63
	5300	60	15.71
	5320	64	15.68
	5500	100	15.80
	5580	116	15.77
	5660	132	15.61
	5720	144	15.88
	5745	149	16.00
	5785	157	15.51
	5825	165	15.09

Table 10.4.4 IEEE 802.11a Average RF Power (Ant.1)

Mode	Freq.	Channel	IEEE 802.11a (5 GHz) Conducted Power
	(MHz)		(dBm)
802.11a	5180	36	15.47
	5200	40	15.41
	5220	44	15.60
	5240	48	15.63
	5260	52	15.62
	5280	56	15.74
	5300	60	15.77
	5320	64	15.80
	5500	100	15.81
	5580	116	15.93
	5660	132	15.89
	5720	144	15.63
	5745	149	15.58
	5785	157	15.99
	5825	165	15.88

Table 10.4.5 IEEE 802.11a Average RF Power (Ant.2)

Mode	Freq.	Channel	IEEE 802.11a (5 GHz) Conducted Power	
	(MHz)		CDD(dBm)	SDM(dBm)
802.11a	5180	36	18.48	-
	5200	40	18.48	-
	5220	44	18.54	-
	5240	48	<u>18.65</u>	-
	5260	52	18.66	-
	5280	56	18.70	-
	5300	60	<u>18.75</u>	-
	5320	64	<u>18.75</u>	-
	5500	100	18.82	-
	5580	116	<u>18.86</u>	-
	5660	132	18.76	-
	5720	144	<u>18.77</u>	-
	5745	149	<u>18.81</u>	-
	5785	157	18.77	-
5825	165	18.51	-	

Table 10.4.6 IEEE 802.11a Average RF Power (MIMO)

Mode	Freq.	Channel	IEEE 802.11n HT20 (5 GHz) Conducted Power
	(MHz)		(dBm)
802.11n (HT-20)	5180	36	14.39
	5200	40	14.43
	5220	44	14.35
	5240	48	14.56
	5260	52	14.56
	5280	56	14.55
	5300	60	14.57
	5320	64	14.61
	5500	100	14.74
	5580	116	14.59
	5660	132	14.50
	5720	144	14.82
	5745	149	14.87
	5785	157	14.38
5825	165	14.45	

Table 10.4.7 IEEE 802.11n HT20 Average RF Power (Ant.1)

Mode	Freq.	Channel	IEEE 802.11n HT20 (5 GHz) Conducted Power
	(MHz)		(dBm)
802.11n (HT-20)	5180	36	14.32
	5200	40	14.34
	5220	44	14.58
	5240	48	14.65
	5260	52	14.52
	5280	56	14.74
	5300	60	14.72
	5320	64	14.62
	5500	100	14.74
	5580	116	14.90
	5660	132	14.80
	5720	144	14.63
	5745	149	14.62
	5785	157	15.00
5825	165	14.83	

Table 10.4.8 IEEE 802.11n HT20 Average RF Power (Ant.2)

Mode	Freq.	Channel	IEEE 802.11n HT20 (5 GHz) Conducted Power	
	(MHz)		CDD(dBm)	SDM(dBm)
802.11n (HT-20)	5180	36	17.37	17.59
	5200	40	17.40	17.60
	5220	44	17.48	17.74
	5240	48	17.62	17.84
	5260	52	17.55	17.78
	5280	56	17.66	17.86
	5300	60	17.66	17.81
	5320	64	17.63	17.77
	5500	100	17.75	17.95
	5580	116	17.76	17.93
	5660	132	17.66	17.81
	5720	144	17.74	17.88
	5745	149	17.76	17.86
	5785	157	17.71	17.81
5825	165	17.65	17.81	

Table 10.4.9 IEEE 802.11n HT20 Average RF Power (MIMO)

Mode	Freq.	Channel	IEEE 802.11ac VHT20 (5 GHz) Conducted Power
	(MHz)		(dBm)
802.11ac (VHT-20)	5180	36	14.37
	5200	40	14.45
	5220	44	14.37
	5240	48	14.58
	5260	52	14.56
	5280	56	14.54
	5300	60	14.52
	5320	64	14.62
	5500	100	14.74
	5580	116	14.66
	5660	132	14.49
	5720	144	14.87
	5745	149	14.83
	5785	157	14.48
	5825	165	14.50

Table 10.4.10 IEEE 802.11ac VHT20 Average RF Power (Ant.1)

Mode	Freq.	Channel	IEEE 802.11ac VHT20 (5 GHz) Conducted Power
	(MHz)		(dBm)
802.11ac (VHT-20)	5180	36	14.36
	5200	40	14.37
	5220	44	14.61
	5240	48	14.68
	5260	52	14.54
	5280	56	14.70
	5300	60	14.72
	5320	64	14.63
	5500	100	14.75
	5580	116	14.76
	5660	132	14.86
	5720	144	14.60
	5745	149	14.65
	5785	157	14.98
	5825	165	14.88

Table 10.4.11 IEEE 802.11ac VHT20 Average RF Power (Ant.2)

Mode	Freq.	Channel	IEEE 802.11ac VHT20 (5 GHz) Conducted Power	
	(MHz)		CDD(dBm)	SDM(dBm)
802.11ac (VHT-20)	5180	36	17.38	17.59
	5200	40	17.42	17.62
	5220	44	17.50	17.76
	5240	48	17.64	17.87
	5260	52	17.56	17.80
	5280	56	17.63	17.88
	5300	60	17.63	17.83
	5320	64	17.64	17.85
	5500	100	17.76	17.90
	5580	116	17.72	17.87
	5660	132	17.69	17.79
	5720	144	17.75	17.92
	5745	149	17.75	17.85
	5785	157	17.75	17.80
	5825	165	17.70	17.67

Table 10.4.12 IEEE 802.11ac VHT20 Average RF Power (MIMO)

Mode	Freq.	Channel	IEEE 802.11n HT40 (5 GHz) Conducted Power	
	(MHz)		(dBm)	
802.11n (HT-40)	5190	38	11.54	
	5230	46	13.54	
	5270	54	13.66	
	5310	62	10.70	
	5510	102	11.78	
	5550	110	13.64	
	5670	134	13.49	
	5710	142	13.81	
	5755	151	13.95	
	5795	159	13.61	

Table 10.4.13 IEEE 802.11n HT40 Average RF Power (Ant.1)

Mode	Freq.	Channel	IEEE 802.11n HT40 (5 GHz) Conducted Power	
	(MHz)		(dBm)	
802.11n (HT-40)	5190	38	11.57	
	5230	46	13.74	
	5270	54	13.79	
	5310	62	10.97	
	5510	102	11.75	
	5550	110	13.81	
	5670	134	13.66	
	5710	142	13.56	
	5755	151	13.68	
	5795	159	13.82	

Table 10.4.14 IEEE 802.11n HT40 Average RF Power (Ant.2)

Mode	Freq.	Channel	IEEE 802.11n HT40 (5 GHz) Conducted Power	
	(MHz)		CDD(dBm)	SDM(dBm)
802.11n (HT-40)	5190	38	14.57	14.63
	5230	46	16.65	16.79
	5270	54	16.74	16.93
	5310	62	13.85	13.87
	5510	102	14.78	14.97
	5550	110	16.74	16.82
	5670	134	16.59	16.64
	5710	142	16.70	16.69
	5755	151	16.83	16.84
	5795	159	16.73	16.76

Table 10.4.15 IEEE 802.11n HT40 Average RF Power (MIMO)

Mode	Freq.	Channel	IEEE 802.11ac VHT40 (5 GHz) Conducted Power
	(MHz)		(dBm)
802.11ac (VHT-40)	5190	38	11.53
	5230	46	13.52
	5270	54	13.65
	5310	62	10.66
	5510	102	11.76
	5550	110	13.65
	5670	134	13.56
	5710	142	13.79
	5755	151	13.83
	5795	159	13.61

Table 10.4.16 IEEE 802.11ac VHT40 Average RF Power (Ant.1)

Mode	Freq.	Channel	IEEE 802.11ac VHT40 (5 GHz) Conducted Power
	(MHz)		(dBm)
802.11ac (VHT-40)	5190	38	11.51
	5230	46	13.75
	5270	54	13.78
	5310	62	10.94
	5510	102	11.75
	5550	110	13.69
	5670	134	13.63
	5710	142	13.59
	5755	151	13.70
	5795	159	13.82

Table 10.4.17 IEEE 802.11ac VHT40 Average RF Power (Ant.2)

Mode	Freq.	Channel	IEEE 802.11ac VHT40 (5 GHz) Conducted Power	
	(MHz)		CDD(dBm)	SDM(dBm)
802.11ac (VHT-40)	5190	38	14.53	14.61
	5230	46	16.65	16.78
	5270	54	16.73	16.84
	5310	62	13.81	13.83
	5510	102	14.77	14.87
	5550	110	16.68	16.89
	5670	134	16.61	16.63
	5710	142	16.70	16.78
	5755	151	16.78	16.87
	5795	159	16.73	16.75

Table 10.4.18 IEEE 802.11ac VHT40 Average RF Power (MIMO)

Mode	Freq.	Channel	IEEE 802.11ac VHT80 (5 GHz) Conducted Power	
	(MHz)		(dBm)	
802.11ac (VHT-80)	5210	42	11.15	
	5290	58	10.14	
	5530	106	11.11	
	5690	138	13.45	
	5775	155	13.25	

Table 10.4.19 IEEE 802.11ac VHT80 Average RF Power (Ant.1)

Mode	Freq.	Channel	IEEE 802.11ac VHT80 (5 GHz) Conducted Power	
	(MHz)		(dBm)	
802.11ac (VHT-80)	5210	42	11.29	
	5290	58	10.53	
	5530	106	11.38	
	5690	138	13.29	
	5775	155	13.33	

Table 10.4.20 IEEE 802.11ac VHT80 Average RF Power (Ant.2)

Mode	Freq.	Channel	IEEE 802.11ac VHT80 (5 GHz) Conducted Power	
	(MHz)		CDD(dBm)	SDM(dBm)
802.11ac (VHT-80)	5210	42	14.23	14.44
	5290	58	13.35	13.51
	5530	106	14.26	14.43
	5690	138	16.38	16.44
	5775	155	16.30	16.25

Table 10.4.21 IEEE 802.11ac VHT80 Average RF Power (MIMO)

Justification for reduced test configurations for WIFI channels per KDB Publication 248227 D01v02r02:

- Power measurements were performed for the transmission mode configuration with the highest maximum output power specified for production units.
- For transmission modes with the same maximum output power specification, powers were measured for the largest channel bandwidth, lowest order modulation and lowest data rate.
- For transmission modes with identical maximum specified output power, channel bandwidth, modulation and data rates, power measurements were required for all identical configurations.
- For each transmission mode configuration, powers were measured for the highest and lowest channels; and at the mid-band channel(s) when there were at least 3 channels supported. For configurations with multiple mid-band channels, duo to an even number of channels, both channels were measured.
- Output Power and SAR is not required for 802.11 g/n HT20 channels when the highest reported SAR for DSSS is adjusted by the ratio of OFDM to DSSS specified maximum output power and the adjust SAR is ≤ 1.2 W/kg.
- The underlined data rate and channel above were tested for SAR.

The average output powers of this device were tested by below configuration.

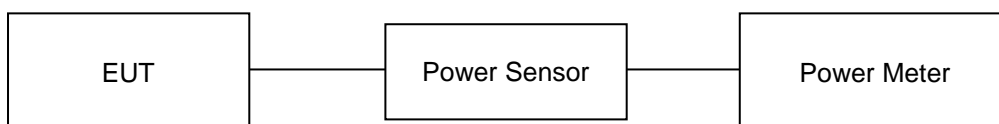

Figure 10.4 Power Measurement Setup

10.5 Bluetooth Conducted Powers

Channel	Frequency	Burst AVG Output Power (1Mbps)	Frame AVG Output Power (1Mbps)	Burst AVG Output Power (2Mbps)	Frame AVG Output Power (2Mbps)	Burst AVG Output Power (3Mbps)	Frame AVG Output Power (3Mbps)
	(MHz)	(dBm)	(dBm)	(dBm)	(dBm)	(dBm)	(dBm)
Low	2402	9.64	8.49	9.03	7.88	9.04	7.89
Mid	2441	10.94	9.79	10.25	9.10	10.25	9.10
High	2480	10.02	8.87	9.33	8.18	9.33	8.18

Table 10.5.1 Bluetooth Frame Average RF Power

Channel	Frequency	Burst AVG Output Power(LE / 1Mbps)	Frame AVG Output Power(LE / 1Mbps)	Burst AVG Output Power(LE / 2Mbps)	Frame AVG Output Power(LE / 2Mbps)
	(MHz)	(dBm)	(dBm)	(dBm)	(dBm)
Low	2402	-0.23	-0.92	-0.19	-2.60
Mid	2440	1.26	0.57	1.23	-1.18
High	2480	0.40	-0.29	0.38	-2.03

Table 10.5.2 Bluetooth LE Frame Average RF Power

● Bluetooth Conducted Powers procedures

1. Bluetooth (BDR, EDR)

1) Enter DUT mode in EUT and operate it.

When it operating, The EUT is transmitting at maximum power level and duty cycle fixed.

2) Instruments and EUT were connected like Figure 10.4(A).

3) The maximum output powers of BDR(1 Mbps), EDR(2, 3 Mbps) and each frequency were set by a Bluetooth Tester.

4) Power levels were measured by a Power Meter.

2. Bluetooth (LE)

1) Enter LE mode in EUT and operate it.

When it operating, The EUT is transmitting at maximum power level and duty cycle fixed.

2) Instruments and EUT were connected like Figure 10.4(B).

3) The average conducted output powers of LE and each frequency can measurement according to setting program in EUT.

4) Power levels were measured by a Power Meter.

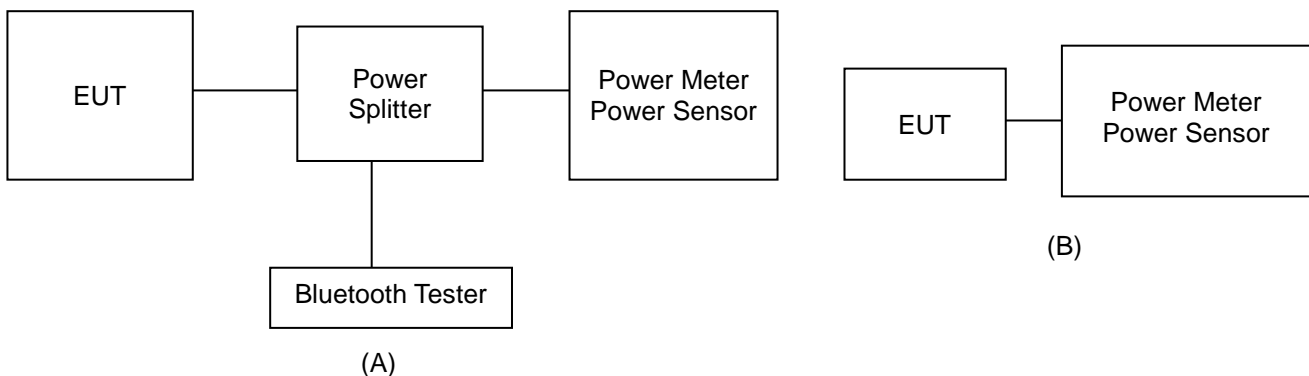

Figure 10.5 Average Power Measurement Setup

The average conducted output powers of Bluetooth were measured using above test setup and a wideband gated RF power meter when the EUT is transmitting at its maximum power level.

Bluetooth Transmission Plot

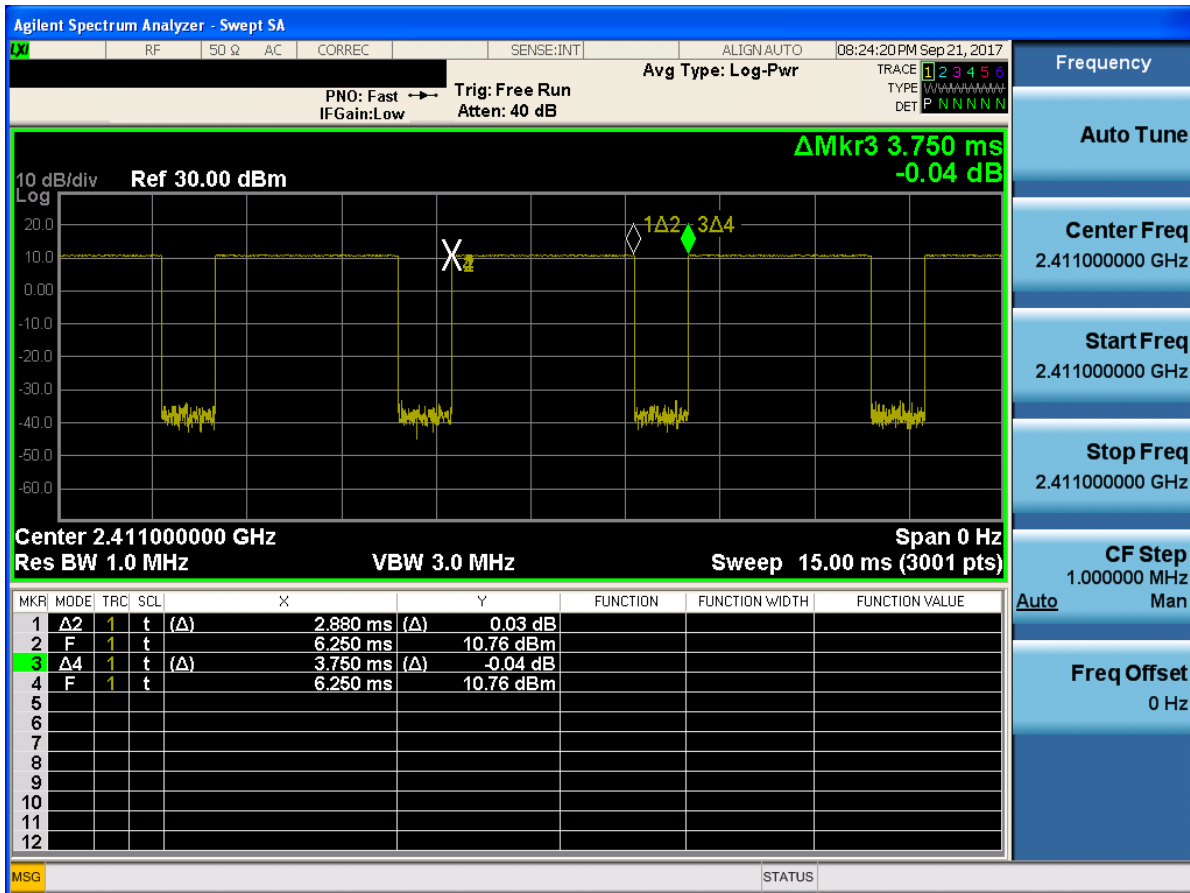

Figure 10.2.2 Bluetooth Transmission Plot

Bluetooth Duty Cycle Calculation

$$\text{Duty Cycle} = \text{Pulse/Period} * 100\% = (2.880/3.750) * 100 = 76.8\%$$

11. SYSTEM VERIFICATION

11.1 Tissue Verification

MEASURED TISSUE PARAMETERS										
Date(s)	Tissue Type	Ambient Temp.[°C]	Liquid Temp.[°C]	Measured Frequency [MHz]	Target Dielectric Constant, ϵ_r	Target Conductivity, σ (S/m)	Measured Dielectric Constant, ϵ_r	Measured Conductivity, σ (S/m)	Er Deviation [%]	σ Deviation [%]
Sep. 12. 2017	750 Head	22.2	22.1	710.0	42.113	0.887	41.404	0.854	-1.68	-3.72
				750.0	41.900	0.890	40.856	0.891	-2.49	0.11
				782.0	41.749	0.894	40.421	0.922	-3.18	3.13
Sep. 13. 2017	750 Body	21.9	21.6	710.0	55.687	0.960	54.030	0.925	-2.98	-3.65
				750.0	55.531	0.963	53.609	0.962	-3.46	-0.10
				782.0	55.406	0.966	53.279	0.993	-3.84	2.80
Sep. 07. 2017	835 Head	21.9	21.7	824.2	41.552	0.899	42.844	0.918	3.11	2.11
				826.4	41.542	0.899	42.807	0.920	3.05	2.34
				835.0	41.500	0.900	42.656	0.928	2.79	3.11
				836.6	41.500	0.901	42.634	0.929	2.73	3.11
				846.6	41.500	0.912	42.465	0.938	2.33	2.85
Sep. 08. 2017	835 Body	22.1	22.0	848.8	41.500	0.914	42.595	0.931	2.64	1.86
				824.2	55.243	0.969	53.975	0.989	-2.30	2.06
				826.4	55.235	0.969	53.964	0.991	-2.30	2.27
				835.0	55.200	0.970	53.943	0.998	-2.28	2.89
				836.6	55.197	0.971	53.932	0.999	-2.29	2.88
Sep. 11. 2017	835 Head	22.0	21.7	846.6	55.166	0.984	53.877	1.007	-2.34	2.34
				848.8	55.160	0.986	53.864	1.008	-2.35	2.23
				835.0	41.500	0.900	42.595	0.918	2.64	2.00
				836.5	41.500	0.901	42.580	0.919	2.60	2.00
				835.0	55.200	0.970	54.334	1.001	-1.57	3.20
Sep. 11. 2017	835 Body	22.0	21.9	836.5	55.197	0.971	54.329	1.002	-1.57	3.19
				1712.4	40.126	1.350	39.357	1.336	-1.92	-1.04
Sep. 14. 2017	1800 Head	22.0	21.8	1732.4	40.097	1.361	39.344	1.355	-1.88	-0.44
				1752.6	40.069	1.373	39.323	1.373	-1.86	0.00
				1800.0	40.000	1.400	39.183	1.421	-2.04	1.50
				1712.4	53.596	1.464	51.791	1.501	-3.37	2.53
Sep. 14. 2017	1800 Body	22.0	21.9	1732.4	53.556	1.477	51.728	1.519	-3.41	2.84
				1752.6	53.516	1.489	51.663	1.536	-3.46	3.16
				1800.0	53.300	1.520	51.542	1.575	-3.30	3.62
				1850.2	40.000	1.400	40.185	1.347	0.46	-3.79
Sep. 05. 2017	1900 Head	21.5	21.4	1852.4	40.000	1.400	40.174	1.349	0.43	-3.64
				1880.0	40.000	1.400	39.996	1.374	-0.01	-1.86
				1900.0	40.000	1.400	39.877	1.393	-0.31	-0.50
				1907.6	40.000	1.400	39.831	1.401	-0.42	0.07
				1909.8	40.000	1.400	39.820	1.403	-0.45	0.21
				1850.2	53.300	1.520	52.158	1.517	-2.14	-0.20
Sep. 06. 2017	1900 Body	21.4	21.2	1852.4	53.300	1.520	52.150	1.519	-2.16	-0.07
				1880.0	53.300	1.520	52.054	1.546	-2.34	1.71
				1900.0	53.300	1.520	51.963	1.568	-2.51	3.16
				1907.6	53.300	1.520	51.934	1.576	-2.56	3.68
				1909.8	53.300	1.520	51.923	1.578	-2.58	3.82
				2412.0	39.265	1.766	39.686	1.819	1.07	3.00
Sep. 07. 2017	2450 Head	21.4	22.2	2437.0	39.222	1.788	39.594	1.851	0.95	3.52
				2450.0	39.200	1.800	39.550	1.867	0.89	3.72
				2462.0	39.184	1.813	39.515	1.880	0.84	3.70
				2412.0	52.751	1.914	50.871	1.925	-3.56	0.57
Sep. 08. 2017	2450 Body	21.4	21.9	2437.0	52.717	1.938	50.817	1.953	-3.60	0.77
				2450.0	52.700	1.950	50.790	1.967	-3.62	0.87
				2462.0	52.685	1.967	50.766	1.978	-3.64	0.56
				2402.0	39.282	1.757	38.236	1.718	-2.66	-2.22
Sep. 22. 2017	2450 Head	21.3	21.7	2441.0	39.215	1.792	38.107	1.760	-2.83	-1.79
				2450.0	39.200	1.800	38.079	1.770	-2.86	-1.67
				2480.0	39.160	1.832	37.980	1.800	-3.01	-1.75
				2402.0	52.764	1.904	50.800	1.909	-3.72	0.26
Sep. 22. 2017	2450 Body	21.3	22.0	2441.0	52.712	1.941	50.743	1.955	-3.74	0.72
				2450.0	52.700	1.950	50.728	1.966	-3.74	0.82
				2480.0	52.662	1.993	50.669	2.000	-3.78	0.35

MEASURED TISSUE PARAMETERS										
Date(s)	Tissue Type	Ambient Temp.[°C]	Liquid Temp.[°C]	Measured Frequency [MHz]	Target Dielectric Constant, ϵ_r	Target Conductivity, σ (S/m)	Measured Dielectric Constant, ϵ_r	Measured Conductivity, σ (S/m)	Er Deviation [%]	σ Deviation [%]
Sep. 11. 2017	5200 Body	21.3	21.8	5180.0	49.041	5.276	47.960	5.335	-2.20	1.12
				5190.0	49.028	5.288	47.941	5.348	-2.22	1.13
				5200.0	49.014	5.299	47.919	5.362	-2.23	1.19
				5220.0	48.987	5.323	47.883	5.390	-2.25	1.26
				5230.0	48.974	5.334	47.863	5.404	-2.27	1.31
				5240.0	48.960	5.346	47.844	5.417	-2.28	1.33
Sep. 12. 2017	5300 Head	21.6	21.9	5260.0	35.940	4.720	36.268	4.820	0.91	2.12
				5270.0	35.930	4.730	36.248	4.833	0.89	2.18
				5280.0	35.920	4.740	36.228	4.846	0.86	2.24
				5300.0	35.900	4.760	36.198	4.871	0.83	2.33
				5310.0	35.890	4.770	36.184	4.883	0.82	2.37
				5320.0	35.880	4.780	36.168	4.896	0.80	2.43
Sep. 13. 2017	5300 Body	21.4	21.8	5260.0	48.933	5.369	48.041	5.484	-1.82	2.14
				5270.0	48.919	5.381	48.015	5.498	-1.85	2.17
				5280.0	48.906	5.393	47.991	5.513	-1.87	2.23
				5300.0	48.879	5.416	47.951	5.541	-1.90	2.31
				5310.0	48.865	5.428	47.929	5.555	-1.92	2.34
				5320.0	48.851	5.439	47.913	5.570	-1.92	2.41
Sep. 14. 2017	5600 Head	21.7	21.9	5500.0	35.650	4.965	35.767	5.020	0.33	1.11
				5510.0	35.635	4.976	35.752	5.030	0.33	1.09
				5550.0	35.575	5.018	35.672	5.077	0.27	1.18
				5580.0	35.530	5.049	35.618	5.115	0.25	1.31
				5600.0	35.500	5.070	35.590	5.141	0.25	1.40
				5660.0	35.440	5.130	35.493	5.206	0.15	1.48
				5670.0	35.430	5.140	35.470	5.217	0.11	1.50
				5710.0	35.390	5.180	35.393	5.269	0.01	1.72
				5720.0	35.380	5.190	35.381	5.281	0.00	1.75
				5800.0	35.300	5.270	35.244	5.372	-0.16	1.94
Sep. 15. 2017	5600 Body	21.5	22.0	5500.0	48.607	5.650	46.950	5.717	-3.41	1.19
				5510.0	48.594	5.661	46.936	5.729	-3.41	1.20
				5550.0	48.539	5.708	46.860	5.783	-3.46	1.31
				5580.0	48.499	5.743	46.801	5.824	-3.50	1.41
				5600.0	48.471	5.766	46.765	5.854	-3.52	1.53
				5660.0	48.390	5.836	46.662	5.934	-3.57	1.68
				5670.0	48.376	5.848	46.641	5.947	-3.59	1.69
				5710.0	48.322	5.895	46.569	6.006	-3.63	1.88
				5720.0	48.309	5.907	46.556	6.020	-3.63	1.91
				5800.0	48.200	6.000	46.408	6.129	-3.72	2.15
Sep. 18. 2017	5800 Head	21.7	21.9	5745.0	35.355	5.215	34.845	5.289	-1.44	1.42
				5755.0	35.345	5.225	34.824	5.302	-1.47	1.47
				5785.0	35.315	5.255	34.774	5.335	-1.53	1.52
				5795.0	35.305	5.265	34.753	5.347	-1.56	1.56
				5800.0	35.300	5.270	34.745	5.353	-1.57	1.57
				5825.0	35.275	5.296	34.704	5.383	-1.62	1.64
Sep. 19. 2017	5800 Body	21.8	22.2	5745.0	48.275	5.936	46.665	6.008	-3.34	1.21
				5755.0	48.261	5.947	46.650	6.023	-3.34	1.28
				5785.0	48.220	5.982	46.601	6.061	-3.36	1.32
				5795.0	48.207	5.994	46.581	6.075	-3.37	1.35
				5800.0	48.200	6.000	46.573	6.082	-3.38	1.37
				5825.0	48.166	6.029	46.531	6.118	-3.39	1.48

The above measured tissue parameters were used in the DASY software. The DASY software was used to perform interpolation to determine the dielectric parameters at the SAR test device frequencies (per KDB 865664 and IEEE 1528-2013 6.6.1.2). The tissue parameters listed in the SAR test plots may slightly differ from the table above due to significant digit rounding in the software. Extremity SAR was tested using body-equivalent tissue dielectric parameters found in KDB Publication 648474D04v01r03.

Measurement Procedure for Tissue verification:

- 1) The network analyzer and probe system was configured and calibrated.
- 2) The probe was immersed in the sample which was placed in a nonmetallic container. Trapped air bubbles beneath the flange were minimized by placing the probe at a slight angle.
- 3) The complex admittance with respect to the probe aperture was measured
- 4) The complex relative permittivity, for example from the below equation (Pournaropoulos and Mtsra).

$$Y = \frac{j2\omega\epsilon_r\epsilon_0}{\ln(b/a)^2} \int_a^b \int_a^b \int_0^\pi \cos\phi' \frac{\exp[-j\omega r(\mu_0\epsilon_r\epsilon_0)^{1/2}]}{r} d\phi' d\rho' d\rho$$

where Y is the admittance of the probe in contact with the sample, the primed and unprimed coordinates refer to source and observation points, respectively, $r^2 = \rho^2 + \rho'^2 - 2\rho\rho'\cos\phi'$, ω is the angular frequency, and $j = \sqrt{-1}$.

11.2 Test System Verification

Prior to assessment, the system is verified to the $\pm 10\%$ of the specifications at 750 MHz, 835 MHz, 1800 MHz, 1900 MHz, 2450 MHz and 5GHz by using the SAR Dipole kit(s). (Graphic Plots Attached)

Table 11.2.1 System Verification Results (1g)

SYSTEM DIPOLE VERIFICATION TARGET & MEASURED												
SAR System #	Freq. [MHz]	SAR Dipole kits	Date(s)	Tissue Type	Ambient Temp. [°C]	Liquid Temp. [°C]	Probe S/N	Input Power (mW)	1 W Target SAR _{1g} (W/kg)	Measured SAR _{1g} (W/kg)	1 W Normalized SAR _{1g} (W/kg)	Deviation [%]
C	750	D750V3, SN:1049	Sep. 12. 2017	Head	22.2	22.1	3328	250	8.51	2.06	8.24	-3.17
C	750	D750V3, SN:1049	Sep. 13. 2017	Body	21.9	21.6	3328	250	8.63	2.22	8.88	2.90
C	835	D835V2, SN:4d159	Sep. 07. 2017	Head	21.9	21.7	3328	250	9.33	2.41	9.64	3.32
C	835	D835V2, SN:4d159	Sep. 08. 2017	Body	22.1	22.0	3328	250	9.57	2.43	9.72	1.57
C	835	D835V2, SN:4d159	Sep. 11. 2017	Head	22.0	21.7	3328	250	9.33	2.46	9.84	5.47
C	835	D835V2, SN:4d159	Sep. 11. 2017	Body	22.0	21.9	3328	250	9.57	2.46	9.84	2.82
C	1800	D1800V2, SN:2d047	Sep. 14. 2017	Head	22.0	21.8	3328	250	39.9	9.77	39.08	-2.06
C	1800	D1800V2, SN:2d047	Sep. 14. 2017	Body	22.0	21.9	3328	250	39.2	9.88	39.52	0.82
C	1900	D1900V2, SN:5d176	Sep. 05. 2017	Head	21.5	21.4	3328	250	40.9	10.00	40.00	-2.20
C	1900	D1900V2, SN: 5d176	Sep. 06. 2017	Body	21.4	21.2	3328	250	39.3	9.87	39.48	0.46
D	2450	D2450V2, SN: 920	Sep. 07. 2017	Head	21.4	22.2	3930	250	52.5	12.90	51.60	-1.71
D	2450	D2450V2, SN: 920	Sep. 08. 2017	Body	21.4	21.9	3930	250	51.0	13.00	52.00	1.96
D	2450	D2450V2, SN: 920	Sep. 22. 2017	Head	21.3	21.7	3930	250	52.5	12.50	50.00	-4.76
D	2450	D2450V2, SN: 920	Sep. 22. 2017	Body	21.3	22.0	3930	250	51.0	13.20	52.80	3.53
D	5200	D5GHzV2, SN:1103	Sep. 11. 2017	Body	21.3	21.8	3930	100	74.1	7.32	73.20	-1.21
D	5300	D5GHzV2, SN:1103	Sep. 12. 2017	Head	21.6	21.9	3930	100	84.1	8.10	81.00	-3.69
D	5300	D5GHzV2, SN:1103	Sep. 13. 2017	Body	21.4	21.8	3930	100	76.7	7.49	74.90	-2.35
D	5600	D5GHzV2, SN:1103	Sep. 14. 2017	Head	21.7	21.9	3930	100	84.5	9.03	90.30	6.86
D	5600	D5GHzV2, SN:1103	Sep. 15. 2017	Body	21.5	22.0	3930	100	80.1	8.32	83.20	3.87
D	5800	D5GHzV2, SN:1103	Sep. 14. 2017	Head	21.7	21.9	3930	100	81.1	8.17	81.70	0.74
D	5800	D5GHzV2, SN:1103	Sep. 15. 2017	Body	21.5	22.0	3930	100	77.5	7.85	78.50	1.29
D	5800	D5GHzV2, SN:1103	Sep. 18. 2017	Head	21.7	21.9	3930	100	81.1	8.40	84.00	3.58
D	5800	D5GHzV2, SN:1103	Sep. 19. 2017	Body	21.8	22.2	3930	100	77.5	7.80	78.00	0.65

Table 11.2.2 System Verification Results (10g)
SYSTEM DIPOLE VERIFICATION TARGET & MEASURED

SAR System #	Freq. [MHz]	SAR Dipole kits	Date(s)	Tissue Type	Ambient Temp. [°C]	Liquid Temp. [°C]	Probe S/N	Input Power (mW)	1 W Target SAR _{10g} (W/kg)	Measured SAR _{10g} (W/kg)	1 W Normalized SAR _{10g} (W/kg)	Deviation [%]
D	5300	D5GHzV2, SN:1103	Sep. 13. 2017	Body	21.4	21.8	3930	100	21.6	2.07	20.70	-4.17
D	5600	D5GHzV2, SN:1103	Sep. 15. 2017	Body	21.5	22.0	3930	100	22.4	2.29	22.90	2.23
D	5800	D5GHzV2, SN:1103	Sep. 15. 2017	Body	21.5	22.0	3930	100	21.5	21.7	21.7	0.93

Note1 : System Verification was measured with input 250 mW, 100 mW (5200-5800 MHz) and normalized to 1W.

Note2 : To confirm the proper SAR liquid depth, the z-axis plots from the system verifications were included since the system verifications were performed using the same liquid, probe and DAE as the SAR tests in the same time period.

Note3: Full system validation status and results can be found in Attachment 3.

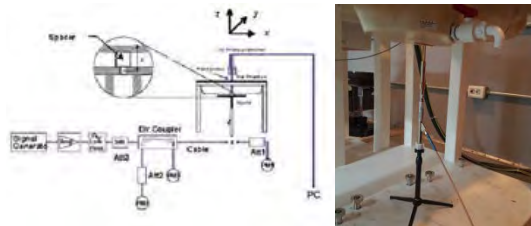
Figure 11.1 Dipole Verification Test Setup Diagram & Photo

12. SAR TEST RESULTS

12.1 Head SAR Results

Table 12.1.1 GSM/GPRS 850 Head SAR

MEASUREMENT RESULTS														
FREQUENCY		Mode/ Band	Service	Maximum Allowed Power [dBm]	Conducted Power [dBm]	Drift Power [dB]	Phantom Position	Device Serial Number	# of Time Slots	Duty Cycle	1g SAR (W/kg)	Scaling Factor	1g Scaled SAR (W/kg)	Plots #
MHz	Ch													
836.6	190	GSM850	GSM	33.7	33.40	0.110	Left Touch	FCC #1	1	1:8.3	0.182	1.072	0.195	A1
836.6	190	GSM850	GSM	33.7	33.40	-0.110	Right Touch	FCC #1	1	1:8.3	0.102	1.072	0.109	
836.6	190	GSM850	GSM	33.7	33.40	-0.010	Left Tilt	FCC #1	1	1:8.3	0.090	1.072	0.096	
836.6	190	GSM850	GSM	33.7	33.40	0.030	Right Tilt	FCC #1	1	1:8.3	0.068	1.072	0.073	
836.6	190	GSM850	GPRS	31.7	31.40	0.090	Left Touch	FCC #1	2	1:4.15	0.234	1.072	0.251	A2
836.6	190	GSM850	GPRS	31.7	31.40	0.030	Right Touch	FCC #1	2	1:4.15	0.127	1.072	0.136	
836.6	190	GSM850	GPRS	31.7	31.40	-0.060	Left Tilt	FCC #1	2	1:4.15	0.114	1.072	0.122	
836.6	190	GSM850	GPRS	31.7	31.40	-0.110	Right Tilt	FCC #1	2	1:4.15	0.083	1.072	0.089	
ANSI / IEEE C95.1-1992- SAFETY LIMIT Spatial Peak Uncontrolled Exposure/General Population Exposure								Head 1.6 W/kg (mW/g) averaged over 1 gram						

Table 12.1.2 PCS/GPRS 1900 Head SAR

MEASUREMENT RESULTS														
FREQUENCY		Mode/ Band	Service	Maximum Allowed Power [dBm]	Conducted Power [dBm]	Drift Power [dB]	Phantom Position	Device Serial Number	# of Time Slots	Duty Cycle	1g SAR (W/kg)	Scaling Factor	1g Scaled SAR (W/kg)	Plots #
MHz	Ch													
1880.0	661	PCS1900	PCS	31.7	31.10	0.170	Left Touch	FCC #1	1	1:8.3	0.158	1.148	0.181	A3
1880.0	661	PCS1900	PCS	31.7	31.10	0.100	Right Touch	FCC #1	1	1:8.3	0.131	1.148	0.150	
1880.0	661	PCS1900	PCS	31.7	31.10	0.020	Left Tilt	FCC #1	1	1:8.3	0.134	1.148	0.154	
1880.0	661	PCS1900	PCS	31.7	31.10	0.020	Right Tilt	FCC #1	1	1:8.3	0.090	1.148	0.103	
1880.0	661	PCS1900	GPRS	29.7	29.40	0.040	Left Touch	FCC #1	2	1:4.15	0.212	1.072	0.227	A4
1880.0	661	PCS1900	GPRS	29.7	29.40	0.090	Right Touch	FCC #1	2	1:4.15	0.191	1.072	0.205	
1880.0	661	PCS1900	GPRS	29.7	29.40	0.150	Left Tilt	FCC #1	2	1:4.15	0.181	1.072	0.194	
1880.0	661	PCS1900	GPRS	29.7	29.40	0.100	Right Tilt	FCC #1	2	1:4.15	0.131	1.072	0.140	
ANSI / IEEE C95.1-1992- SAFETY LIMIT Spatial Peak Uncontrolled Exposure/General Population Exposure								Head 1.6 W/kg (mW/g) averaged over 1 gram						

Table 12.1.3 WCDMA 850 Head SAR

MEASUREMENT RESULTS													
FREQUENCY		Mode/ Band	Service	Maximum Allowed Power [dBm]	Conducted Power [dBm]	Drift Power [dB]	Phantom Position	Device Serial Number	Duty Cycle	1g SAR (W/kg)	Scaling Factor	1g Scaled SAR (W/kg)	Plots #
MHz	Ch												
836.6	4183	WCDMA 850	RMC	25.2	24.87	0.010	Left Touch	FCC #1	1:1	0.235	1.079	0.254	A5
836.6	4183	WCDMA 850	RMC	25.2	24.87	-0.150	Right Touch	FCC #1	1:1	0.149	1.079	0.161	
836.6	4183	WCDMA 850	RMC	25.2	24.87	0.090	Left Tilt	FCC #1	1:1	0.120	1.079	0.129	
836.6	4183	WCDMA 850	RMC	25.2	24.87	0.120	Right Tilt	FCC #1	1:1	0.105	1.079	0.113	
ANSI / IEEE C95.1-1992- SAFETY LIMIT Spatial Peak Uncontrolled Exposure/General Population Exposure									Head 1.6 W/kg (mW/g) averaged over 1 gram				

Table 12.1.4 WCDMA 1700 Head SAR

MEASUREMENT RESULTS													
FREQUENCY		Mode/ Band	Service	Maximum Allowed Power [dBm]	Conducted Power [dBm]	Drift Power [dB]	Phantom Position	Device Serial Number	Duty Cycle	1g SAR (W/kg)	Scaling Factor	1g Scaled SAR (W/kg)	Plots #
MHz	Ch												
1732.4	1412	WCDMA 1700	RMC	23.2	22.68	0.070	Left Touch	FCC #1	1:1	0.148	1.127	0.167	A6
1732.4	1412	WCDMA 1700	RMC	23.2	22.68	0.130	Right Touch	FCC #1	1:1	0.127	1.127	0.143	
1732.4	1412	WCDMA 1700	RMC	23.2	22.68	0.120	Left Tilt	FCC #1	1:1	0.085	1.127	0.096	
1732.4	1412	WCDMA 1700	RMC	23.2	22.68	0.160	Right Tilt	FCC #1	1:1	0.086	1.127	0.097	
ANSI / IEEE C95.1-2005- SAFETY LIMIT Spatial Peak Uncontrolled Exposure/General Population Exposure									Head 1.6 W/kg (mW/g) averaged over 1 gram				

Table 12.1.5 WCDMA 1900 Head SAR

MEASUREMENT RESULTS													
FREQUENCY		Mode/ Band	Service	Maximum Allowed Power [dBm]	Conducted Power [dBm]	Drift Power [dB]	Phantom Position	Device Serial Number	Duty Cycle	1g SAR (W/kg)	Scaling Factor	1g Scaled SAR (W/kg)	Plots #
MHz	Ch												
1880.0	9400	WCDMA 1900	RMC	23.2	22.66	0.130	Left Touch	FCC #1	1:1	0.183	1.132	0.207	A7
1880.0	9400	WCDMA 1900	RMC	23.2	22.66	0.050	Right Touch	FCC #1	1:1	0.160	1.132	0.181	
1880.0	9400	WCDMA 1900	RMC	23.2	22.66	-0.160	Left Tilt	FCC #1	1:1	0.161	1.132	0.182	
1880.0	9400	WCDMA 1900	RMC	23.2	22.66	0.170	Right Tilt	FCC #1	1:1	0.100	1.132	0.113	
ANSI / IEEE C95.1-1992- SAFETY LIMIT Spatial Peak Uncontrolled Exposure/General Population Exposure									Head 1.6 W/kg (mW/g) averaged over 1 gram				

Table 12.1.6 LTE Band 17 Head SAR

MEASUREMENT RESULTS																	
FREQUENCY		Mode/ Band	BW [MHz]	Max Allowed Power [dBm]	Cond. PWR [dBm]	Drift Power [dB]	MPR	Position	Device Serial Number	Mod.	RB Size	RB Offs.	Duty Cycle	1g SAR (W/kg)	Scaling Factor	1g Scaled SAR (W/kg)	Plots #
MHz	Ch																
710.0	23790	LTE B17	10	25.2	24.92	-0.040	0	Left Touch	FCC #1	QPSK	1	25	1:1	0.089	1.067	0.095	A8
710.0	23790	LTE B17	10	24.2	23.89	0.180	1	Left Touch	FCC #1	QPSK	25	0	1:1	0.073	1.074	0.078	
710.0	23790	LTE B17	10	25.2	24.92	0.150	0	Right Touch	FCC #1	QPSK	1	25	1:1	0.077	1.067	0.082	
710.0	23790	LTE B17	10	24.2	23.89	0.050	1	Right Touch	FCC #1	QPSK	25	0	1:1	0.065	1.074	0.070	
710.0	23790	LTE B17	10	25.2	24.92	0.120	0	Left Tilt	FCC #1	QPSK	1	25	1:1	0.048	1.067	0.051	
710.0	23790	LTE B17	10	24.2	23.89	0.110	1	Left Tilt	FCC #1	QPSK	25	0	1:1	0.038	1.074	0.041	
710.0	23790	LTE B17	10	25.2	24.92	0.070	0	Right Tilt	FCC #1	QPSK	1	25	1:1	0.082	1.067	0.087	
710.0	23790	LTE B17	10	24.2	23.89	0.040	1	Right Tilt	FCC #1	QPSK	25	0	1:1	0.064	1.074	0.069	
ANSI / IEEE C95.1-1992- SAFETY LIMIT Spatial Peak Uncontrolled Exposure/General Population Exposure										Head 1.6 W/kg (mW/g) averaged over 1 gram							

Table 12.1.7 LTE Band 13 Head SAR

MEASUREMENT RESULTS																	
FREQUENCY		Mode/ Band	BW [MHz]	Max Allowed Power [dBm]	Cond. PWR [dBm]	Drift Power [dB]	MPR	Position	Device Serial Number	Mod.	RB Size	RB Offs.	Duty Cycle	1g SAR (W/kg)	Scaling Factor	1g Scaled SAR (W/kg)	Plots #
MHz	Ch																
782.0	23230	LTE B13	10	24.2	23.76	0.110	0	Left Touch	FCC #1	QPSK	1	25	1:1	0.057	1.107	0.063	A9
782.0	23230	LTE B13	10	23.2	22.02	0.110	1	Left Touch	FCC #1	QPSK	25	25	1:1	0.039	1.312	0.051	
782.0	23230	LTE B13	10	24.2	23.76	0.130	0	Right Touch	FCC #1	QPSK	1	25	1:1	0.042	1.107	0.046	
782.0	23230	LTE B13	10	23.2	22.02	-0.050	1	Right Touch	FCC #1	QPSK	25	25	1:1	0.028	1.312	0.037	
782.0	23230	LTE B13	10	24.2	23.76	0.090	0	Left Tilt	FCC #1	QPSK	1	25	1:1	0.024	1.107	0.027	
782.0	23230	LTE B13	10	23.2	22.02	0.080	1	Left Tilt	FCC #1	QPSK	25	25	1:1	0.017	1.312	0.022	
782.0	23230	LTE B13	10	24.2	23.76	-0.170	0	Right Tilt	FCC #1	QPSK	1	25	1:1	0.032	1.107	0.035	
782.0	23230	LTE B13	10	23.2	22.02	-0.140	1	Right Tilt	FCC #1	QPSK	25	25	1:1	0.020	1.312	0.026	
ANSI / IEEE C95.1-1992- SAFETY LIMIT Spatial Peak Uncontrolled Exposure/General Population Exposure										Head 1.6 W/kg (mW/g) averaged over 1 gram							

Table 12.1.8 LTE Band 5 (Cell) Head SAR

MEASUREMENT RESULTS																	
FREQUENCY		Mode/ Band	BW [MHz]	Max Allowed Power [dBm]	Cond. PWR [dBm]	Drift Power [dB]	MPR	Position	Device Serial Number	Mod.	RB Size	RB Offs.	Duty Cycle	1g SAR (W/kg)	Scaling Factor	1g Scaled SAR (W/kg)	Plots #
MHz	Ch																
836.5	20525	LTE B5	10	25.2	24.91	0.160	0	Left Touch	FCC #1	QPSK	1	49	1:1	0.207	1.069	0.221	A10
836.5	20525	LTE B5	10	24.2	23.80	0.190	1	Left Touch	FCC #1	QPSK	25	12	1:1	0.166	1.096	0.182	
836.5	20525	LTE B5	10	25.2	24.91	0.090	0	Right Touch	FCC #1	QPSK	1	49	1:1	0.138	1.069	0.148	
836.5	20525	LTE B5	10	24.2	23.80	-0.190	1	Right Touch	FCC #1	QPSK	25	12	1:1	0.107	1.096	0.117	
836.5	20525	LTE B5	10	25.2	24.91	0.160	0	Left Tilt	FCC #1	QPSK	1	49	1:1	0.105	1.069	0.112	
836.5	20525	LTE B5	10	24.2	23.80	0.060	1	Left Tilt	FCC #1	QPSK	25	12	1:1	0.080	1.096	0.088	
836.5	20525	LTE B5	10	25.2	24.91	-0.030	0	Right Tilt	FCC #1	QPSK	1	49	1:1	0.119	1.069	0.127	
836.5	20525	LTE B5	10	24.2	23.80	0.080	1	Right Tilt	FCC #1	QPSK	25	12	1:1	0.084	1.096	0.092	
ANSI / IEEE C95.1-1992- SAFETY LIMIT Spatial Peak Uncontrolled Exposure/General Population Exposure										Head 1.6 W/kg (mW/g) averaged over 1 gram							

Table 12.1.9 DTS Head SAR

MEASUREMENT RESULTS																
FREQUENCY		Mode (Antenna)	Maximum Allowed Power [dBm]	Conducted Power [dBm]	Drift Power [dB]	Phantom Position	Device Serial Number	Peak SAR of Area Scan	Data Rate [Mbps]	Duty Cycle	1g SAR (W/kg)	Scaling Factor	Scaling Factor (Duty Cycle)	1g Scaled SAR (W/kg)	Plot s #	
MHz	Ch															
2437	6	802.11b (Ant.1)	16.0	15.69	-0.100	Left Touch	FCC #2	0.105	1	98.8	0.101	1.074	1.012	0.110		
2437	6	802.11b (Ant.1)	16.0	15.69	-0.150	Right Touch	FCC #2	0.419	1	98.8	0.445	1.074	1.012	0.484	A11	
2437	6	802.11b (Ant.1)	16.0	15.69	0.090	Left Tilt	FCC #2	0.058	1	98.8	0.057	1.074	1.012	0.062		
2437	6	802.11b (Ant.1)	16.0	15.69	0.160	Right Tilt	FCC #2	0.222	1	98.8	0.215	1.074	1.012	0.234		
2412	1	802.11b (Ant.2)	16.0	15.74	-0.110	Left Touch	FCC #2	0.275	1	98.8	0.277	1.062	1.012	0.298		
2412	1	802.11b (Ant.2)	16.0	15.74	0.110	Right Touch	FCC #2	0.682	1	98.8	0.585	1.062	1.012	0.629		
2412	1	802.11b (Ant.2)	16.0	15.74	-0.150	Left Tilt	FCC #2	0.356	1	98.8	0.386	1.062	1.012	0.415		
2412	1	802.11b (Ant.2)	16.0	15.74	0.110	Right Tilt	FCC #2	0.544	1	98.8	0.604	1.062	1.012	0.649	A12	
2412	1	802.11b (MIMO)	19.0	18.67	0.050	Left Touch	FCC #2	0.345	1	98.8	0.335	1.079	1.012	0.366		
2412	1	802.11b (MIMO)	19.0	18.67	0.160	Right Touch	FCC #2	0.904	1	98.8	0.827	1.079	1.012	0.903	A13	
2437	6	802.11b (MIMO)	19.0	18.63	-0.080	Right Touch	FCC #2	0.741	1	98.8	0.700	1.089	1.012	0.771		
2412	1	802.11b (MIMO)	19.0	18.67	0.010	Left Tilt	FCC #2	0.438	1	98.8	0.456	1.079	1.012	0.498		
2412	1	802.11b (MIMO)	19.0	18.67	-0.000	Right Tilt	FCC #2	0.620	1	98.8	0.694	1.079	1.012	0.758		
2412	1	802.11b (MIMO)	19.0	18.67	0.100	Right Touch	FCC #2	0.902	1	98.8	0.821	1.079	1.012	0.896		
ANSI / IEEE C95.1-1992- SAFETY LIMIT Spatial Peak Uncontrolled Exposure/General Population Exposure										Head 1.6 W/kg (mW/g) averaged over 1 gram						

Note(s):

- Highest reported SAR is ≤ 0.4 W/kg. Therefore, further SAR measurements within this exposure condition are not required.
- Highest reported SAR is > 0.4 W/kg. Due to the highest reported SAR for this test position, other test position is Head exposure condition were evaluated until a SAR ≤ 0.8 W/kg was reported.
- Highest reported SAR is > 0.8 W/kg. SAR is measured for these test positions/configurations on the subsequent next highest measured output power channel(s) until the reported SAR is ≤ 1.2 W/kg or all required channels are tested.
- Blue entries represent variability measurements.

Adjusted SAR results for OFDM SAR												
FREQUENCY		Mode/ Antenna	Service	Maximum Allowed Power [dBm]	1g Scaled SAR (W/kg)	FREQUENCY [MHz]	Mode	Service	Maximum Allowed Power [dBm]	Ratio of OFDM to DSSS	1g Adjusted SAR (W/kg)	Determine OFDM SAR
MHz	Ch											
2437	6	802.11b (Ant.1)	DSSS	16.0	0.484	2437	802.11g	OFDM	16.0	1.000	0.484	X
2437	6	802.11b (Ant.1)	DSSS	16.0	0.484	2437	802.11n	OFDM	15.0	0.794	0.384	X
2437	6	802.11b (Ant.1)	DSSS	16.0	0.484	2437	802.11ac	OFDM	15.0	0.794	0.384	X
2412	1	802.11b (Ant.2)	DSSS	16.0	0.649	2412	802.11g	OFDM	16.0	1.000	0.649	X
2412	1	802.11b (Ant.2)	DSSS	16.0	0.649	2412	802.11n	OFDM	15.0	0.794	0.515	X
2412	1	802.11b (Ant.2)	DSSS	16.0	0.649	2412	802.11ac	OFDM	15.0	0.794	0.515	X
2412	1	802.11b (MIMO)	DSSS	19.0	0.903	2412	802.11g	OFDM	19.0	1.000	0.903	X
2412	1	802.11b (MIMO)	DSSS	19.0	0.903	2412	802.11n	OFDM	18.0	0.794	0.717	X
2412	1	802.11b (MIMO)	DSSS	19.0	0.903	2412	802.11ac	OFDM	18.0	0.794	0.717	X
ANSI / IEEE C95.1-1992– SAFETY LIMIT Spatial Peak Uncontrolled Exposure/General Population Exposure							Head 1.6 W/kg (mW/g) averaged over 1 gram					

Note: SAR is not required for the following 2.4 GHz OFDM conditions. When the highest reported SAR for DSSS is adjusted by the ratio of OFDM to DSSS specified maximum output power and the adjusted SAR is ≤ 1.2 W/kg.

Table 12.1.10 Bluetooth Head SAR

MEASUREMENT RESULTS														
FREQUENCY		Mode	Maximum Allowed Power [dBm]	Conducted Power [dBm]	Drift Power [dB]	Phantom Position	Device Serial Number	Rate [Mbps]	Duty Cycle (%)	1g SAR (W/kg)	Scaling Factor	Scaling Factor (Duty Cycle)	1g Scaled SAR (W/kg)	Plots #
MHz	Ch													
2441	39	Bluetooth	11.5	9.79	0.190	Left Touch	FCC #1	1	76.8	0.018	1.483	1.302	0.035	
2441	39	Bluetooth	11.5	9.79	0.080	Right Touch	FCC #1	1	76.8	0.118	1.483	1.302	0.228	A58
2441	39	Bluetooth	11.5	9.79	0.170	Left Tilt	FCC #1	1	76.8	0.00997	1.483	1.302	0.019	
2441	39	Bluetooth	11.5	9.79	0.080	Right Tilt	FCC #1	1	76.8	0.042	1.483	1.302	0.081	
ANSI / IEEE C95.1-1992– SAFETY LIMIT Spatial Peak Uncontrolled Exposure/General Population Exposure							Head 1.6 W/kg (mW/g) averaged over 1 gram							

Table 12.1.11 UNII Head SAR

MEASUREMENT RESULTS

FREQUENCY		Mode (Antenna)	Maximum Allowed Power [dBm]	Conducted Power [dBm]	Drift Power [dB]	Phantom Position	Device Serial Number	Peak SAR of Area Scan	Data Rate [Mbps]	Duty Cycle	1g SAR (W/kg)	Scaling Factor	Scaling Factor (Duty Cycle)	1g Scaled SAR (W/kg)	Plot s #
MHz	Ch														
5300	60	802.11a (Ant.1)	16.0	15.71	0.000	Left Touch	FCC #2	0.076	6	98.1	0.059	1.069	1.020	0.064	
5300	60	802.11a (Ant.1)	16.0	15.71	0.180	Right Touch	FCC #2	0.168	6	98.1	0.161	1.069	1.020	0.176	A14
5300	60	802.11a (Ant.1)	16.0	15.71	0.000	Left Tilt	FCC #2	0.066	6	98.1	0.055	1.069	1.020	0.060	
5300	60	802.11a (Ant.1)	16.0	15.71	0.150	Right Tilt	FCC #2	0.132	6	98.1	0.144	1.069	1.020	0.157	
5320	64	802.11a (Ant.2)	16.0	15.80	-0.160	Left Touch	FCC #2	0.264	6	98.1	0.224	1.047	1.020	0.239	
5320	64	802.11a (Ant.2)	16.0	15.80	0.080	Right Touch	FCC #2	0.456	6	98.1	0.549	1.047	1.020	0.586	
5320	64	802.11a (Ant.2)	16.0	15.80	-0.130	Left Tilt	FCC #2	0.302	6	98.1	0.271	1.047	1.020	0.289	
5320	64	802.11a (Ant.2)	16.0	15.80	-0.130	Right Tilt	FCC #2	0.521	6	98.1	0.644	1.047	1.020	0.688	A15
5300	60	802.11a (MIMO)	19.0	18.75	0.180	Left Touch	FCC #2	0.298	6	98.1	0.288	1.069	1.020	0.314	
5300	60	802.11a (MIMO)	19.0	18.75	0.180	Right Touch	FCC #2	0.587	6	98.1	0.720	1.069	1.020	0.785	
5300	60	802.11a (MIMO)	19.0	18.75	-0.060	Left Tilt	FCC #2	0.382	6	98.1	0.381	1.069	1.020	0.415	
5300	60	802.11a (MIMO)	19.0	18.75	0.000	Right Tilt	FCC #2	0.696	6	98.1	0.869	1.069	1.020	0.948	A16
5320	64	802.11a (MIMO)	19.0	18.75	-0.110	Right Tilt	FCC #2	0.665	6	98.1	0.823	1.069	1.020	0.897	
5300	60	802.11a (MIMO)	19.0	18.75	0.020	Right Tilt	FCC #2	0.702	6	98.1	0.856	1.069	1.020	0.933	
ANSI / IEEE C95.1-1992- SAFETY LIMIT									Head						
Spatial Peak									1.6 W/kg (mW/g)						
Uncontrolled Exposure/General Population Exposure									averaged over 1 gram						

- Note(s):
- Highest reported SAR is ≤ 0.4 W/kg. Therefore, further SAR measurements within this exposure condition are not required.
 - Highest reported SAR is > 0.4 W/kg. Due to the highest reported SAR for this test position, other test position is Head exposure condition were evaluated until a SAR ≤ 0.8 W/kg was reported.
 - Highest reported SAR is > 0.8 W/kg. SAR is measured for these test positions/configurations on the subsequent next highest measured output power channel(s) until the reported SAR is ≤ 1.2 W/kg or all required channels are tested.
 - Blue entries represent variability measurements.

Adjusted SAR results for UNII-1 and UNII-2A SAR

FREQUENCY		Mode/ Antenna	Service	Maximum Allowed Power [dBm]	1g Scaled SAR (W/kg)	FREQUENCY [MHz]	Mode	Service	Maximum Allowed Power [dBm]	Adjusted Factor	1g Adjusted SAR (W/kg)	SAR for the band with lower maximum output power
MHz	Ch											
5300	60	802.11a (Ant.1)	OFDM	16.0	0.176	5300	802.11a	OFDM	16.0	1.000	0.176	X
5320	64	802.11a (Ant.2)	OFDM	16.0	0.688	5320	802.11a	OFDM	16.0	1.000	0.688	X
5300	60	802.11a (MIMO)	OFDM	19.0	0.948	5300	802.11a	OFDM	19.0	1.000	0.948	X
ANSI / IEEE C95.1-1992- SAFETY LIMIT									Head			
Spatial Peak									1.6 W/kg (mW/g)			
Uncontrolled Exposure/General Population Exposure									averaged over 1 gram			

- Note(s):
- U-NII-1 and U-NII-2A Bands: When different maximum output power is specified for the bands, begin SAR measurement in the band with higher specified maximum output power. The highest reported SAR for the tested configuration is adjusted by the ratio of lower to higher specified maximum output power for the two bands. When the adjusted SAR is ≤ 1.2 W/kg, SAR is not required for the band with lower maximum output power in that test configuration.

Table 12.1.12 UNII Head SAR

MEASUREMENT RESULTS

FREQUENCY		Mode (Antenna)	Maximum Allowed Power [dBm]	Conducted Power [dBm]	Drift Power [dB]	Phantom Position	Device Serial Number	Peak SAR of Area Scan	Data Rate [Mbps]	Duty Cycle	1g SAR (W/kg)	Scaling Factor	Scaling Factor (Duty Cycle)	1g Scaled SAR (W/kg)	Plots #
MHz	Ch														
5720	144	802.11a (Ant.1)	16.0	15.88	0.170	Left Touch	FCC #2	0.100	6	98.1	0.066	1.028	1.020	0.069	
5720	144	802.11a (Ant.1)	16.0	15.88	0.060	Right Touch	FCC #2	0.241	6	98.1	0.262	1.028	1.020	0.275	A17
5720	144	802.11a (Ant.1)	16.0	15.88	0.010	Left Tilt	FCC #2	0.096	6	98.1	0.096	1.028	1.020	0.101	
5720	144	802.11a (Ant.1)	16.0	15.88	-0.170	Right Tilt	FCC #2	0.191	6	98.1	0.206	1.028	1.020	0.216	
5580	116	802.11a (Ant.2)	16.0	15.93	0.160	Left Touch	FCC #2	0.120	6	98.1	0.106	1.016	1.020	0.110	
5580	116	802.11a (Ant.2)	16.0	15.93	0.110	Right Touch	FCC #2	0.135	6	98.1	0.177	1.016	1.020	0.183	
5580	116	802.11a (Ant.2)	16.0	15.93	0.000	Left Tilt	FCC #2	0.159	6	98.1	0.149	1.016	1.020	0.154	
5580	116	802.11a (Ant.2)	16.0	15.93	-0.100	Right Tilt	FCC #2	0.208	6	98.1	0.200	1.016	1.020	0.207	A18
5580	116	802.11a (MIMO)	19.0	18.86	-0.010	Left Touch	FCC #2	0.200	6	98.1	0.203	1.033	1.020	0.214	
5580	116	802.11a (MIMO)	19.0	18.86	-0.130	Right Touch	FCC #2	0.432	6	98.1	0.498	1.033	1.020	0.525	
5580	116	802.11a (MIMO)	19.0	18.86	0.000	Left Tilt	FCC #2	0.217	6	98.1	0.213	1.033	1.020	0.224	
5580	116	802.11a (MIMO)	19.0	18.86	0.090	Right Tilt	FCC #2	0.454	6	98.1	0.576	1.033	1.020	0.607	A19
5745	149	802.11a (Ant.1)	16.0	16.00	0.000	Left Touch	FCC #2	0.104	6	98.1	0.079	1.000	1.020	0.081	
5745	149	802.11a (Ant.1)	16.0	16.00	-0.080	Right Touch	FCC #2	0.367	6	98.1	0.376	1.000	1.020	0.384	A20
5745	149	802.11a (Ant.1)	16.0	16.00	0.000	Left Tilt	FCC #2	0.090	6	98.1	0.077	1.000	1.020	0.079	
5745	149	802.11a (Ant.1)	16.0	16.00	0.080	Right Tilt	FCC #2	0.173	6	98.1	0.194	1.000	1.020	0.198	
5785	157	802.11a (Ant.2)	16.0	15.99	0.000	Left Touch	FCC #2	0.100	6	98.1	0.093	1.002	1.020	0.095	
5785	157	802.11a (Ant.2)	16.0	15.99	-0.080	Right Touch	FCC #2	0.125	6	98.1	0.161	1.002	1.020	0.165	
5785	157	802.11a (Ant.2)	16.0	15.99	0.000	Left Tilt	FCC #2	0.137	6	98.1	0.117	1.002	1.020	0.120	
5785	157	802.11a (Ant.2)	16.0	15.99	-0.030	Right Tilt	FCC #2	0.165	6	98.1	0.172	1.002	1.020	0.176	A21
5745	149	802.11a (MIMO)	19.0	18.81	0.000	Left Touch	FCC #2	0.153	6	98.1	0.139	1.045	1.020	0.148	
5745	149	802.11a (MIMO)	19.0	18.81	-0.190	Right Touch	FCC #2	0.483	6	98.1	0.521	1.045	1.020	0.555	A22
5745	149	802.11a (MIMO)	19.0	18.81	0.000	Left Tilt	FCC #2	0.191	6	98.1	0.182	1.045	1.020	0.194	
5745	149	802.11a (MIMO)	19.0	18.81	-0.080	Right Tilt	FCC #2	0.351	6	98.1	0.376	1.045	1.020	0.401	
ANSI / IEEE C95.1-1992- SAFETY LIMIT Spatial Peak Uncontrolled Exposure/General Population Exposure								Head 1.6 W/kg (mW/g) averaged over 1 gram							

Note(s):

- Highest reported SAR is ≤ 0.4 W/kg. Therefore, further SAR measurements within this exposure condition are not required.
- Highest reported SAR is > 0.4 W/kg. Due to the highest reported SAR for this test position, other test position is Head exposure condition were evaluated until a SAR ≤ 0.8 W/kg was reported.

12.2 Standalone Body-Worn SAR Worn SAR Results

Table 12.2.1 GSM/PCS/GPRS/WCDMA Body-Worn SAR

MEASUREMENT RESULTS														
FREQUENCY		Mode/ Band	Service	Maximum Allowed Power [dBm]	Conducted Power [dBm]	Drift Power [dB]	Spacing [Side]	Device Serial Number	# of Time Slot s	Duty Cycle	1g SAR (W/kg)	Scaling Factor	1g Scaled SAR (W/kg)	Plots #
MHz	Ch													
836.6	190	GSM850	GSM	33.7	33.40	-0.010	10 mm [Front]	FCC #1	1	1:8.3	0.477	1.072	0.511	
836.6	190	GSM850	GSM	33.7	33.40	-0.070	10 mm [Rear]	FCC #1	1	1:8.3	0.538	1.072	0.577	A23
836.6	190	GSM850	GPRS	31.7	31.40	0.000	10 mm [Front]	FCC #1	2	1:4.15	0.634	1.072	0.680	
836.6	190	GSM850	GPRS	31.7	31.40	0.000	10 mm [Rear]	FCC #1	2	1:4.15	0.696	1.072	0.746	A24
1880.0	661	PCS1900	PCS	31.7	31.10	-0.140	10 mm [Front]	FCC #1	1	1:8.3	0.623	1.148	0.715	A25
1880.0	661	PCS1900	PCS	31.7	31.10	-0.030	10 mm [Rear]	FCC #1	1	1:8.3	0.591	1.148	0.678	
1850.2	512	PCS1900	GPRS	29.7	29.40	-0.040	10 mm [Front]	FCC #1	2	1:4.15	0.869	1.072	0.932	
1880.0	661	PCS1900	GPRS	29.7	29.40	0.010	10 mm [Front]	FCC #1	2	1:4.15	0.923	1.072	0.989	A26
1909.8	810	PCS1900	GPRS	29.7	29.40	-0.030	10 mm [Front]	FCC #1	2	1:4.15	0.832	1.072	0.892	
1850.2	512	PCS1900	GPRS	29.7	29.40	-0.020	10 mm [Rear]	FCC #1	2	1:4.15	0.784	1.072	0.840	
1880.0	661	PCS1900	GPRS	29.7	29.40	-0.070	10 mm [Rear]	FCC #1	2	1:4.15	0.814	1.072	0.873	
1909.8	810	PCS1900	GPRS	29.7	29.40	-0.010	10 mm [Rear]	FCC #1	2	1:4.15	0.783	1.072	0.839	
1880.0	661	PCS1900	GPRS	29.7	29.40	-0.020	10 mm [Front]	FCC #1	2	1:4.15	0.910	1.072	0.976	
836.6	4183	WCDMA 850	RMC	25.2	24.87	0.030	10 mm [Front]	FCC #1	N/A	1:1	0.653	1.079	0.705	
836.6	4183	WCDMA 850	RMC	25.2	24.87	-0.020	10 mm [Rear]	FCC #1	N/A	1:1	0.703	1.079	0.759	A27
1732.4	1412	WCDMA 1700	RMC	23.2	22.68	-0.030	10 mm [Front]	FCC #1	N/A	1:1	0.444	1.127	0.500	A28
1732.4	1412	WCDMA 1700	RMC	23.2	22.68	-0.040	10 mm [Rear]	FCC #1	N/A	1:1	0.435	1.127	0.490	
1852.4	9262	WCDMA 1900	RMC	23.2	22.66	-0.050	10 mm [Front]	FCC #1	N/A	1:1	0.800	1.132	0.906	
1880.0	9400	WCDMA 1900	RMC	23.2	22.66	-0.050	10 mm [Front]	FCC #1	N/A	1:1	0.826	1.132	0.935	
1907.6	9538	WCDMA 1900	RMC	23.2	22.69	-0.050	10 mm [Front]	FCC #1	N/A	1:1	0.850	1.125	0.956	A29
1852.4	9262	WCDMA 1900	RMC	23.2	22.66	-0.030	10 mm [Rear]	FCC #1	N/A	1:1	0.701	1.132	0.794	
1880.0	9400	WCDMA 1900	RMC	23.2	22.66	-0.010	10 mm [Rear]	FCC #1	N/A	1:1	0.727	1.132	0.823	
1907.6	9538	WCDMA 1900	RMC	23.2	22.69	-0.010	10 mm [Rear]	FCC #1	N/A	1:1	0.766	1.125	0.862	
ANSI / IEEE C95.1-1992- SAFETY LIMIT Spatial Peak								Body 1.6 W/kg (mW/g) averaged over 1 gram						
Uncontrolled Exposure/General Population Exposure														

Note(s):

- Blue entries represent variability measurements.

Table 12.2.2 LTE B17, LTE B13, LTE B5 Body-Worn SAR

MEASUREMENT RESULTS

FREQUENCY		Mode/ Band	BW [MHz]	Max Allowed Power [dBm]	Cond. PWR [dBm]	Drift Power [dB]	MPR	Position	Device Serial Number	Mod.	RB Size	RB Offs.	Duty Cycle	1g SAR (W/kg)	Scaling Factor	1g Scaled SAR (W/kg)	Plots #
MHz	Ch																
710.0	23790	LTE B17	10	25.2	24.92	-0.030	0	10 mm [Front]	FCC #1	QPSK	1	25	1:1	0.397	1.067	0.424	
710.0	23790	LTE B17	10	24.2	23.89	-0.010	1	10 mm [Front]	FCC #1	QPSK	25	0	1:1	0.312	1.074	0.335	
710.0	23790	LTE B17	10	25.2	24.92	-0.030	0	10 mm [Rear]	FCC #1	QPSK	1	25	1:1	0.429	1.067	0.458	A30
710.0	23790	LTE B17	10	24.2	23.89	-0.050	1	10 mm [Rear]	FCC #1	QPSK	25	0	1:1	0.340	1.074	0.365	
782.0	23230	LTE B13	10	24.2	23.76	-0.030	0	10 mm [Front]	FCC #1	QPSK	1	25	1:1	0.213	1.107	0.236	
782.0	23230	LTE B13	10	23.2	22.02	-0.010	1	10 mm [Front]	FCC #1	QPSK	25	25	1:1	0.143	1.312	0.188	
782.0	23230	LTE B13	10	24.2	23.76	0.050	0	10 mm [Rear]	FCC #1	QPSK	1	25	1:1	0.245	1.107	0.271	A31
782.0	23230	LTE B13	10	23.2	22.02	-0.000	1	10 mm [Rear]	FCC #1	QPSK	25	25	1:1	0.164	1.312	0.215	
836.5	20525	LTE B5	10	25.2	24.91	-0.030	0	10 mm [Front]	FCC #1	QPSK	1	49	1:1	0.622	1.069	0.665	
836.5	20525	LTE B5	10	24.2	23.80	-0.030	1	10 mm [Front]	FCC #1	QPSK	25	12	1:1	0.497	1.096	0.545	
836.5	20525	LTE B5	10	25.2	24.91	-0.010	0	10 mm [Rear]	FCC #1	QPSK	1	49	1:1	0.682	1.069	0.729	A32
836.5	20525	LTE B5	10	24.2	23.80	-0.010	1	10 mm [Rear]	FCC #1	QPSK	25	12	1:1	0.517	1.096	0.567	
ANSI / IEEE C95.1-1992- SAFETY LIMIT Spatial Peak Uncontrolled Exposure/General Population Exposure									Body 1.6 W/kg (mW/g) averaged over 1 gram								

Table 12.2.3 DTS Body-Worn SAR

MEASUREMENT RESULTS															
FREQUENCY		Mode	Maximum Allowed Power [dBm]	Conducted Power [dBm]	Drift Power [dB]	Phantom Position	Device Serial Number	Peak SAR of Area Scan	Data Rate [Mbps]	Duty Cycle	1g SAR (W/kg)	Scaling Factor	Scaling Factor (Duty Cycle)	SAR (W/kg)	Plots #
MHz	Ch														
2437	6	802.11b (Ant.1)	16.0	15.69	-0.110	10 mm [Front]	FCC #2	0.089	1	98.8	0.098	1.074	1.012	0.107	A33
2437	6	802.11b (Ant.1)	16.0	15.69	-0.100	10 mm [Rear]	FCC #2	0.089	1	98.8	0.096	1.074	1.012	0.104	
2412	1	802.11b (Ant.2)	16.0	15.74	0.000	10 mm [Front]	FCC #2	0.115	1	98.8	0.113	1.062	1.012	0.121	
2412	1	802.11b (Ant.2)	16.0	15.74	-0.070	10 mm [Rear]	FCC #2	0.118	1	98.8	0.118	1.062	1.012	0.127	A34
2412	1	802.11b (MIMO)	19.0	18.67	-0.010	10 mm [Front]	FCC #2	0.152	1	98.8	0.146	1.079	1.012	0.159	
2412	1	802.11b (MIMO)	19.0	18.67	0.060	10 mm [Rear]	FCC #2	0.167	1	98.8	0.168	1.079	1.012	0.183	A35
ANSI / IEEE C95.1-1992- SAFETY LIMIT Spatial Peak Uncontrolled Exposure/General Population Exposure								Body 1.6 W/kg (mW/g) averaged over 1 gram							

Note(s):

- Highest reported SAR is ≤ 0.4 W/kg. Therefore, further SAR measurements within this exposure condition are not required.

Adjusted SAR results for OFDM SAR												
FREQUENCY		Model/ Antenna	Service	Maximum Allowed Power [dBm]	1g Scaled SAR (W/kg)	FREQUENCY [MHz]	Mode	Service	Maximum Allowed Power [dBm]	Ratio of OFDM to DSSS	1g Adjusted SAR (W/kg)	Determine OFDM SAR
MHz	Ch											
2437	6	802.11b (Ant.1)	DSSS	16.0	0.107	2437	802.11g	OFDM	16.0	1.000	0.107	X
2437	6	802.11b (Ant.1)	DSSS	16.0	0.107	2437	802.11n	OFDM	15.0	0.794	0.085	X
2437	6	802.11b (Ant.1)	DSSS	16.0	0.107	2437	802.11ac	OFDM	15.0	0.794	0.085	X
2412	1	802.11b (Ant.2)	DSSS	16.0	0.127	2412	802.11g	OFDM	16.0	1.000	0.127	X
2412	1	802.11b (Ant.2)	DSSS	16.0	0.127	2412	802.11n	OFDM	15.0	0.794	0.101	X
2412	1	802.11b (Ant.2)	DSSS	16.0	0.127	2412	802.11ac	OFDM	15.0	0.794	0.101	X
2412	1	802.11b (MIMO)	DSSS	19.0	0.183	2412	802.11g	OFDM	19.0	1.000	0.183	X
2412	1	802.11b (MIMO)	DSSS	19.0	0.183	2412	802.11n	OFDM	18.0	0.794	0.145	X
2412	1	802.11b (MIMO)	DSSS	19.0	0.183	2412	802.11ac	OFDM	18.0	0.794	0.145	X
ANSI / IEEE C95.1-1992- SAFETY LIMIT Spatial Peak Uncontrolled Exposure/General Population Exposure								Body 1.6 W/kg (mW/g) averaged over 1 gram				

Note: SAR is not required for the following 2.4 GHz OFDM conditions. When the highest reported SAR for DSSS is adjusted by the ratio of OFDM to DSSS specified maximum output power and the adjusted SAR is ≤ 1.2 W/kg.

Table 12.2.4 Bluetooth Body-Worn SAR

MEASUREMENT RESULTS														
FREQUENCY		Mode	Maximum Allowed Power [dBm]	Conducted Power [dBm]	Drift Power [dB]	Phantom Position	Device Serial Number	Rate [Mbps]	Duty Cycle (%)	1g SAR (W/kg)	Scaling Factor	Scaling Factor (Duty Cycle)	1g Scaled SAR (W/kg)	Plots #
MHz	Ch													
2441	39	Bluetooth	11.5	9.79	0.080	10 mm [Front]	FCC #1	1	76.8	0.018	1.483	1.302	0.035	A59
2441	39	Bluetooth	11.5	9.79	0.190	10 mm [Rear]	FCC #1	1	76.8	0.016	1.483	1.302	0.031	
ANSI / IEEE C95.1-1992- SAFETY LIMIT Spatial Peak Uncontrolled Exposure/General Population Exposure								Body 1.6 W/kg (mW/g) averaged over 1 gram						

Table 12.2.5 UNII Body-Worn SAR
MEASUREMENT RESULTS

FREQUENCY		Mode	Maximum Allowed Power [dBm]	Conducted Power [dBm]	Drift Power [dB]	Phantom Position	Device Serial Number	Peak SAR of Area Scan	Data Rate [Mbps]	Duty Cycle	1g SAR (W/kg)	Scaling Factor	Scaling Factor (Duty Cycle)	1g Scaled SAR (W/kg)	Plots #
MHz	Ch														
5300	60	802.11a (Ant.1)	16.0	15.71	-0.190	10 mm [Front]	FCC #2	0.047	6	98.1	0.038	1.069	1.020	0.041	
5300	60	802.11a (Ant.1)	16.0	15.71	-0.010	10 mm [Rear]	FCC #2	0.461	6	98.1	0.504	1.069	1.020	0.550	A36
5320	64	802.11a (Ant.2)	16.0	15.80	0.030	10 mm [Front]	FCC #2	0.074	6	98.1	0.055	1.047	1.020	0.059	
5320	64	802.11a (Ant.2)	16.0	15.80	-0.080	10 mm [Rear]	FCC #2	0.361	6	98.1	0.312	1.047	1.020	0.333	A37
5300	60	802.11a (MIMO)	19.0	18.75	0.010	10 mm [Front]	FCC #2	0.089	6	98.1	0.084	1.069	1.020	0.092	
5300	60	802.11a (MIMO)	19.0	18.75	0.020	10 mm [Rear]	FCC #2	0.517	6	98.1	0.520	1.069	1.020	0.567	A38
ANSI / IEEE C95.1-2005– SAFETY LIMIT Spatial Peak Uncontrolled Exposure/General Population Exposure								Body 1.6 W/kg (mW/g) averaged over 1 gram							

- Note(s):
- Highest reported SAR is ≤ 0.4 W/kg. Therefore, further SAR measurements within this exposure condition are not required.
 - Highest reported SAR is > 0.4 W/kg. Due to the highest reported SAR for this test position, other test position is Head exposure condition were evaluated until a SAR ≤ 0.8 W/kg was reported.

Adjusted SAR results for UNII-1 and UNII-2A SAR

FREQUENCY		Mode/ Antenna	Service	Maximum Allowed Power [dBm]	1g Scaled SAR (W/kg)	FREQUENCY [MHz]	Mode	Service	Maximum Allowed Power [dBm]	Adjusted Factor	1g Adjusted SAR (W/kg)	SAR for the band with lower maximum output power
MHz	Ch											
5300	60	802.11a (Ant.1)	OFDM	16.0	0.550	5300	802.11a	OFDM	16.0	1.000	0.550	X
5320	64	802.11a (Ant.2)	OFDM	16.0	0.333	5320	802.11a	OFDM	16.0	1.000	0.333	X
5300	60	802.11a (MIMO)	OFDM	19.0	0.567	5300	802.11a	OFDM	19.0	1.000	0.567	X
ANSI / IEEE C95.1-1992– SAFETY LIMIT Spatial Peak Uncontrolled Exposure/General Population Exposure								Body 1.6 W/kg (mW/g) averaged over 1 gram				

- Note(s):
- U-NII-1 and U-NII-2A Bands: When different maximum output power is specified for the bands, begin SAR measurement in the band with higher specified maximum output power. The highest reported SAR for the tested configuration is adjusted by the ratio of lower to higher specified maximum output power for the two bands. When the adjusted SAR is ≤ 1.2 W/kg, SAR is not required for the band with lower maximum output power in that test configuration.

Table 12.2.6 UNII Body-Worn SAR

MEASUREMENT RESULTS

FREQUENCY		Mode	Maximum Allowed Power [dBm]	Conducted Power [dBm]	Drift Power [dB]	Phantom Position	Device Serial Number	Peak SAR of Area Scan	Data Rate [Mbps]	Duty Cycle	1g SAR (W/kg)	Scaling Factor	Scaling Factor (Duty Cycle)	1g Scaled SAR (W/kg)	Plots #
MHz	Ch														
5720	144	802.11a (Ant.1)	16.0	15.88	-0.190	10 mm [Front]	FCC #2	0.051	6	98.1	0.045	1.028	1.020	0.047	
5720	144	802.11a (Ant.1)	16.0	15.88	-0.100	10 mm [Rear]	FCC #2	0.425	6	98.1	0.456	1.028	1.020	0.478	A39
5580	116	802.11a (Ant.2)	16.0	15.93	-0.140	10 mm [Front]	FCC #2	0.052	6	98.1	0.034	1.016	1.020	0.035	
5580	116	802.11a (Ant.2)	16.0	15.93	-0.040	10 mm [Rear]	FCC #2	0.300	6	98.1	0.304	1.016	1.020	0.315	A40
5580	116	802.11a (MIMO)	19.0	18.86	-0.020	10 mm [Front]	FCC #2	0.076	6	98.1	0.071	1.033	1.020	0.075	
5580	116	802.11a (MIMO)	19.0	18.86	0.090	10 mm [Rear]	FCC #2	0.414	6	98.1	0.478	1.033	1.020	0.504	A41
5745	149	802.11a (Ant.1)	16.0	16.00	-0.050	10 mm [Front]	FCC #2	0.074	6	98.1	0.069	1.000	1.020	0.070	
5745	149	802.11a (Ant.1)	16.0	16.00	-0.040	10 mm [Rear]	FCC #2	0.581	6	98.1	0.624	1.000	1.020	0.636	A42
5785	157	802.11a (Ant.2)	16.0	15.99	0.120	10 mm [Front]	FCC #2	0.023	6	98.1	0.016	1.002	1.020	0.016	
5785	157	802.11a (Ant.2)	16.0	15.99	0.050	10 mm [Rear]	FCC #2	0.186	6	98.1	0.177	1.002	1.020	0.181	A43
5745	149	802.11a (MIMO)	19.0	18.81	-0.140	10 mm [Front]	FCC #2	0.078	6	98.1	0.070	1.045	1.020	0.075	
5745	149	802.11a (MIMO)	19.0	18.81	0.170	10 mm [Rear]	FCC #2	0.455	6	98.1	0.494	1.045	1.020	0.527	A44
ANSI / IEEE C95.1-1992- SAFETY LIMIT Spatial Peak Uncontrolled Exposure/General Population Exposure								Body 1.6 W/kg (mW/g) averaged over 1 gram							

Note(s):

- Highest reported SAR is ≤ 0.4 W/kg. Therefore, further SAR measurements within this exposure condition are not required.
- Highest reported SAR is > 0.4 W/kg. Due to the highest reported SAR for this test position, other test position is Head exposure condition were evaluated until a SAR ≤ 0.8 W/kg was reported.
- Highest reported SAR is > 0.8 W/kg. SAR is measured for these test positions/configurations on the subsequent next highest measured output power channel(s) until the reported SAR is ≤ 1.2 W/kg or all required channels are tested.

12.3 Standalone Hotspot SAR Results

Table 12.3.1 GPRS Hotspot SAR

MEASUREMENT RESULTS														
FREQUENCY		Mode/ Band	Service	Maximum Allowed Power [dBm]	Conducted Power [dBm]	Drift Power [dB]	Spacing [Side]	Device Serial Number	# of Time Slot s	Duty Cycle	1g SAR (W/kg)	Scaling Factor	1g Scaled SAR (W/kg)	Plots #
MHz	Ch													
836.6	190	GSM850	GPRS	31.7	31.40	-0.070	10 mm [Bottom]	FCC #1	2	1:4.15	0.350	1.072	0.375	
836.6	190	GSM850	GPRS	31.7	31.40	0.000	10 mm [Front]	FCC #1	2	1:4.15	0.634	1.072	0.680	
836.6	190	GSM850	GPRS	31.7	31.40	0.000	10 mm [Rear]	FCC #1	2	1:4.15	0.696	1.072	0.746	A24
836.6	190	GSM850	GPRS	31.7	31.40	-0.160	10 mm [Right]	FCC #1	2	1:4.15	0.117	1.072	0.125	
836.6	190	GSM850	GPRS	31.7	31.40	0.070	10 mm [Left]	FCC #1	2	1:4.15	0.321	1.072	0.344	
1850.2	512	PCS1900	GPRS	29.7	29.40	-0.090	10 mm [Bottom]	FCC #1	2	1:4.15	0.818	1.072	0.877	
1880.0	661	PCS1900	GPRS	29.7	29.40	-0.040	10 mm [Bottom]	FCC #1	2	1:4.15	0.921	1.072	0.987	
1909.8	810	PCS1900	GPRS	29.7	29.40	0.010	10 mm [Bottom]	FCC #1	2	1:4.15	0.810	1.072	0.868	
1850.2	512	PCS1900	GPRS	29.7	29.40	-0.040	10 mm [Front]	FCC #1	2	1:4.15	0.869	1.072	0.932	
1880.0	661	PCS1900	GPRS	29.7	29.40	0.010	10 mm [Front]	FCC #1	2	1:4.15	0.923	1.072	0.989	A26
1909.8	810	PCS1900	GPRS	29.7	29.40	-0.030	10 mm [Front]	FCC #1	2	1:4.15	0.832	1.072	0.892	
1850.2	512	PCS1900	GPRS	29.7	29.40	-0.020	10 mm [Rear]	FCC #1	2	1:4.15	0.784	1.072	0.840	
1880.0	661	PCS1900	GPRS	29.7	29.40	-0.070	10 mm [Rear]	FCC #1	2	1:4.15	0.814	1.072	0.873	
1909.8	810	PCS1900	GPRS	29.7	29.40	-0.010	10 mm [Rear]	FCC #1	2	1:4.15	0.783	1.072	0.839	
1880.0	661	PCS1900	GPRS	29.7	29.40	-0.040	10 mm [Left]	FCC #1	2	1:4.15	0.453	1.072	0.486	
1880.0	661	PCS1900	GPRS	29.7	29.40	-0.020	10 mm [Front]	FCC #1	2	1:4.15	0.910	1.072	0.976	
ANSI / IEEE C95.1-1992- SAFETY LIMIT Spatial Peak Uncontrolled Exposure/General Population Exposure								Body 1.6 W/kg (mW/g) averaged over 1 gram						

Note(s):

- Blue entries represent variability measurements.

Table 12.3.2 WCDMA Hotspot SAR

MEASUREMENT RESULTS

FREQUENCY		Mode/ Band	Service	Maximum Allowed Power [dBm]	Conducted Power [dBm]	Drift Power [dB]	Spacing [Side]	Device Serial Number	# of Time Slot s	Duty Cycle	1g SAR (W/kg)	Scaling Factor	1g Scaled SAR (W/kg)	Plots #
MHz	Ch													
836.6	4183	WCDMA 850	RMC	25.2	24.87	0.020	10 mm [Bottom]	FCC #1	N/A	1:1	0.377	1.079	0.407	
836.6	4183	WCDMA 850	RMC	25.2	24.87	0.030	10 mm [Front]	FCC #1	N/A	1:1	0.653	1.079	0.705	
836.6	4183	WCDMA 850	RMC	25.2	24.87	-0.020	10 mm [Rear]	FCC #1	N/A	1:1	0.703	1.079	0.759	A27
836.6	4183	WCDMA 850	RMC	25.2	24.87	-0.150	10 mm [Right]	FCC #1	N/A	1:1	0.124	1.079	0.134	
836.6	4183	WCDMA 850	RMC	25.2	24.87	-0.040	10 mm [Left]	FCC #1	N/A	1:1	0.336	1.079	0.363	
1732.4	1412	WCDMA 1700	RMC	23.2	22.68	0.040	10 mm [Bottom]	FCC #1	N/A	1:1	0.453	1.127	0.511	A45
1732.4	1412	WCDMA 1700	RMC	23.2	22.68	-0.030	10 mm [Front]	FCC #1	N/A	1:1	0.444	1.127	0.500	
1732.4	1412	WCDMA 1700	RMC	23.2	22.68	-0.040	10 mm [Rear]	FCC #1	N/A	1:1	0.435	1.127	0.490	
1732.4	1412	WCDMA 1700	RMC	23.2	22.68	-0.080	10 mm [Left]	FCC #1	N/A	1:1	0.295	1.127	0.332	
1852.4	9262	WCDMA 1900	RMC	23.2	22.66	-0.120	10 mm [Bottom]	FCC #1	N/A	1:1	0.810	1.132	0.917	
1880.0	9400	WCDMA 1900	RMC	23.2	22.66	-0.080	10 mm [Bottom]	FCC #1	N/A	1:1	0.733	1.132	0.830	
1907.6	9538	WCDMA 1900	RMC	23.2	22.69	-0.100	10 mm [Bottom]	FCC #1	N/A	1:1	0.808	1.125	0.909	
1852.4	9262	WCDMA 1900	RMC	23.2	22.66	-0.050	10 mm [Front]	FCC #1	N/A	1:1	0.800	1.132	0.906	
1880.0	9400	WCDMA 1900	RMC	23.2	22.66	-0.050	10 mm [Front]	FCC #1	N/A	1:1	0.826	1.132	0.935	
1907.6	9538	WCDMA 1900	RMC	23.2	22.69	-0.050	10 mm [Front]	FCC #1	N/A	1:1	0.850	1.125	0.956	A29
1852.4	9262	WCDMA 1900	RMC	23.2	22.66	-0.030	10 mm [Rear]	FCC #1	N/A	1:1	0.701	1.132	0.794	
1880.0	9400	WCDMA 1900	RMC	23.2	22.66	-0.010	10 mm [Rear]	FCC #1	N/A	1:1	0.727	1.132	0.823	
1907.6	9538	WCDMA 1900	RMC	23.2	22.69	-0.010	10 mm [Rear]	FCC #1	N/A	1:1	0.766	1.125	0.862	
1880.0	9400	WCDMA 1900	RMC	23.2	22.66	0.150	10 mm [Left]	FCC #1	N/A	1:1	0.372	1.132	0.421	
ANSI / IEEE C95.1-1992– SAFETY LIMIT Spatial Peak Uncontrolled Exposure/General Population Exposure								Body 1.6 W/kg (mW/g) averaged over 1 gram						

Table 12.3.3 LTE B17, LTE B13, LTE B5 Hotspot SAR

MEASUREMENT RESULTS

FREQUENCY		Mode/ Band	BW [MHz]	Max Allowed Power [dBm]	Cond. PWR [dBm]	Drift Power [dB]	MPR	Position	Device Serial Number	Mod.	RB Size	RB Offs.	Duty Cycle	1g SAR (W/kg)	Scaling Factor	1g Scaled SAR (W/kg)	Plots #
MHz	Ch																
710.0	23790	LTE B17	10	25.2	24.92	-0.000	0	10 mm [Bottom]	FCC #1	QPSK	1	25	1:1	0.227	1.067	0.242	
710.0	23790	LTE B17	10	24.2	23.89	0.030	1	10 mm [Bottom]	FCC #1	QPSK	25	0	1:1	0.183	1.074	0.197	
710.0	23790	LTE B17	10	25.2	24.92	-0.030	0	10 mm [Front]	FCC #1	QPSK	1	25	1:1	0.397	1.067	0.424	
710.0	23790	LTE B17	10	24.2	23.89	-0.010	1	10 mm [Front]	FCC #1	QPSK	25	0	1:1	0.312	1.074	0.335	
710.0	23790	LTE B17	10	25.2	24.92	-0.030	0	10 mm [Rear]	FCC #1	QPSK	1	25	1:1	0.429	1.067	0.458	A30
710.0	23790	LTE B17	10	24.2	23.89	-0.050	1	10 mm [Rear]	FCC #1	QPSK	25	0	1:1	0.340	1.074	0.365	
710.0	23790	LTE B17	10	25.2	24.92	-0.170	0	10 mm [Right]	FCC #1	QPSK	1	25	1:1	0.148	1.067	0.158	
710.0	23790	LTE B17	10	24.2	23.89	-0.130	1	10 mm [Right]	FCC #1	QPSK	25	0	1:1	0.115	1.074	0.124	
710.0	23790	LTE B17	10	25.2	24.92	-0.040	0	10 mm [Left]	FCC #1	QPSK	1	25	1:1	0.079	1.067	0.084	
710.0	23790	LTE B17	10	24.2	23.89	-0.020	1	10 mm [Left]	FCC #1	QPSK	25	0	1:1	0.068	1.074	0.073	
782.0	23230	LTE B13	10	24.2	23.76	-0.050	0	10 mm [Bottom]	FCC #1	QPSK	1	25	1:1	0.119	1.107	0.132	
782.0	23230	LTE B13	10	23.2	22.02	-0.180	1	10 mm [Bottom]	FCC #1	QPSK	25	25	1:1	0.079	1.312	0.104	
782.0	23230	LTE B13	10	24.2	23.76	-0.030	0	10 mm [Front]	FCC #1	QPSK	1	25	1:1	0.213	1.107	0.236	
782.0	23230	LTE B13	10	23.2	22.02	-0.010	1	10 mm [Front]	FCC #1	QPSK	25	25	1:1	0.143	1.312	0.188	
782.0	23230	LTE B13	10	24.2	23.76	0.050	0	10 mm [Rear]	FCC #1	QPSK	1	25	1:1	0.245	1.107	0.271	A31
782.0	23230	LTE B13	10	23.2	22.02	-0.000	1	10 mm [Rear]	FCC #1	QPSK	25	25	1:1	0.164	1.312	0.215	
782.0	23230	LTE B13	10	24.2	23.76	0.050	0	10 mm [Right]	FCC #1	QPSK	1	25	1:1	0.055	1.107	0.061	
782.0	23230	LTE B13	10	23.2	22.02	0.020	1	10 mm [Right]	FCC #1	QPSK	25	25	1:1	0.035	1.312	0.046	
782.0	23230	LTE B13	10	24.2	23.76	-0.040	0	10 mm [Left]	FCC #1	QPSK	1	25	1:1	0.103	1.107	0.114	
782.0	23230	LTE B13	10	23.2	22.02	0.030	1	10 mm [Left]	FCC #1	QPSK	25	25	1:1	0.064	1.312	0.084	
836.5	20525	LTE B5	10	25.2	24.91	-0.020	0	10 mm [Bottom]	FCC #1	QPSK	1	49	1:1	0.351	1.069	0.375	
836.5	20525	LTE B5	10	24.2	23.80	-0.170	1	10 mm [Bottom]	FCC #1	QPSK	25	12	1:1	0.279	1.096	0.306	
836.5	20525	LTE B5	10	25.2	24.91	-0.030	0	10 mm [Front]	FCC #1	QPSK	1	49	1:1	0.622	1.069	0.665	
836.5	20525	LTE B5	10	24.2	23.80	-0.030	1	10 mm [Front]	FCC #1	QPSK	25	12	1:1	0.497	1.096	0.545	
836.5	20525	LTE B5	10	25.2	24.91	-0.010	0	10 mm [Rear]	FCC #1	QPSK	1	49	1:1	0.682	1.069	0.729	A32
836.5	20525	LTE B5	10	24.2	23.80	-0.010	1	10 mm [Rear]	FCC #1	QPSK	25	12	1:1	0.517	1.096	0.567	
836.5	20525	LTE B5	10	25.2	24.91	-0.000	0	10 mm [Right]	FCC #1	QPSK	1	49	1:1	0.117	1.069	0.125	
836.5	20525	LTE B5	10	24.2	23.80	0.060	1	10 mm [Right]	FCC #1	QPSK	25	12	1:1	0.092	1.096	0.101	
836.5	20525	LTE B5	10	25.2	24.91	0.020	0	10 mm [Left]	FCC #1	QPSK	1	49	1:1	0.325	1.069	0.347	
836.5	20525	LTE B5	10	24.2	23.80	0.040	1	10 mm [Left]	FCC #1	QPSK	25	12	1:1	0.242	1.096	0.265	
ANSI / IEEE C95.1-1992- SAFETY LIMIT Spatial Peak									Body 1.6 W/kg (mW/g) averaged over 1 gram								
Uncontrolled Exposure/General Population Exposure																	

Table 12.3.4 DTS Hotspot SAR

MEASUREMENT RESULTS															
FREQUENCY		Mode	Maximum Allowed Power [dBm]	Conducted Power [dBm]	Drift Power [dB]	Phantom Position	Device Serial Number	Peak SAR of Area Scan	Data Rate [Mbps]	Duty Cycle	1g SAR (W/kg)	Scaling Factor	Scaling Factor (Duty Cycle)	SAR (W/kg)	Plots #
MHz	Ch														
2437	6	802.11b (Ant.1)	16.0	15.69	-0.010	10 mm [Top]	FCC #2	0.027	1	98.8	0.025	1.074	1.012	0.027	
2437	6	802.11b (Ant.1)	16.0	15.69	-0.110	10 mm [Front]	FCC #2	0.089	1	98.8	0.098	1.074	1.012	0.107	
2437	6	802.11b (Ant.1)	16.0	15.69	-0.100	10 mm [Rear]	FCC #2	0.089	1	98.8	0.096	1.074	1.012	0.104	
2437	6	802.11b (Ant.1)	16.0	15.69	0.140	10 mm [Left]	FCC #2	0.092	1	98.8	0.102	1.074	1.012	0.111	A46
2412	1	802.11b (Ant.2)	16.0	15.74	-0.180	10 mm [Top]	FCC #2	0.157	1	98.8	0.148	1.062	1.012	0.159	A47
2412	1	802.11b (Ant.2)	16.0	15.74	0.000	10 mm [Front]	FCC #2	0.115	1	98.8	0.113	1.062	1.012	0.121	
2412	1	802.11b (Ant.2)	16.0	15.74	-0.070	10 mm [Rear]	FCC #2	0.118	1	98.8	0.118	1.062	1.012	0.127	
2412	1	802.11b (Ant.2)	16.0	15.74	-0.150	10 mm [Left]	FCC #2	0.019	1	98.8	0.018	1.062	1.012	0.019	
2412	1	802.11b (MIMO)	19.0	18.67	-0.090	10 mm [Top]	FCC #2	0.187	1	98.8	0.175	1.079	1.012	0.191	A48
2412	1	802.11b (MIMO)	19.0	18.67	-0.010	10 mm [Front]	FCC #2	0.152	1	98.8	0.146	1.079	1.012	0.159	
2412	1	802.11b (MIMO)	19.0	18.67	0.060	10 mm [Rear]	FCC #2	0.167	1	98.8	0.168	1.079	1.012	0.183	
2412	1	802.11b (MIMO)	19.0	18.67	0.180	10 mm [Left]	FCC #2	0.094	1	98.8	0.137	1.079	1.012	0.150	
ANSI / IEEE C95.1-1992- SAFETY LIMIT								Body							
Spatial Peak								1.6 W/kg (mW/g)							
Uncontrolled Exposure/General Population Exposure								averaged over 1 gram							

Note(s):

- Highest reported SAR is ≤ 0.4 W/kg. Therefore, further SAR measurements within this exposure condition are not required.

Adjusted SAR results for OFDM SAR												
FREQUENCY		Mode/ Antenna	Service	Maximum Allowed Power [dBm]	1g Scaled SAR (W/kg)	FREQUENCY [MHz]	Mode	Service	Maximum Allowed Power [dBm]	Ratio of OFDM to DSSS	1g Adjusted SAR (W/kg)	Determine OFDM SAR
MHz	Ch											
2437	6	802.11b (Ant.1)	DSSS	16.0	0.111	2437	802.11g	OFDM	16.0	1.000	0.111	X
2437	6	802.11b (Ant.1)	DSSS	16.0	0.111	2437	802.11n	OFDM	15.0	0.794	0.088	X
2437	6	802.11b (Ant.1)	DSSS	16.0	0.111	2437	802.11ac	OFDM	15.0	0.794	0.088	X
2412	1	802.11b (Ant.2)	DSSS	16.0	0.159	2412	802.11g	OFDM	16.0	1.000	0.159	X
2412	1	802.11b (Ant.2)	DSSS	16.0	0.159	2412	802.11n	OFDM	15.0	0.794	0.126	X
2412	1	802.11b (Ant.2)	DSSS	16.0	0.159	2412	802.11ac	OFDM	15.0	0.794	0.126	X
2412	1	802.11b (MIMO)	DSSS	19.0	0.191	2412	802.11g	OFDM	19.0	1.000	0.191	X
2412	1	802.11b (MIMO)	DSSS	19.0	0.191	2412	802.11n	OFDM	18.0	0.794	0.152	X
2412	1	802.11b (MIMO)	DSSS	19.0	0.191	2412	802.11ac	OFDM	18.0	0.794	0.152	X
ANSI / IEEE C95.1-1992- SAFETY LIMIT								Body				
Spatial Peak								1.6 W/kg (mW/g)				
Uncontrolled Exposure/General Population Exposure								averaged over 1 gram				

Note: SAR is not required for the following 2.4 GHz OFDM conditions. When the highest reported SAR for DSSS is adjusted by the ratio of OFDM to DSSS specified maximum output power and the adjusted SAR is ≤ 1.2 W/kg.

Table 12.2.5 Bluetooth Hotspot SAR

MEASUREMENT RESULTS														
FREQUENCY		Mode	Maximum Allowed Power [dBm]	Conducted Power [dBm]	Drift Power [dB]	Phantom Position	Device Serial Number	Rate [Mbps]	Duty Cycle (%)	1g SAR (W/kg)	Scaling Factor	Scaling Factor (Duty Cycle)	1g Scaled SAR (W/kg)	Plots #
MHz	Ch													
2441	39	Bluetooth	11.5	9.79	0.170	10 mm [Top]	FCC #1	1	76.8	0.00867	1.483	1.302	0.017	
2441	39	Bluetooth	11.5	9.79	0.080	10 mm [Front]	FCC #1	1	76.8	0.018	1.483	1.302	0.035	
2441	39	Bluetooth	11.5	9.79	0.190	10 mm [Rear]	FCC #1	1	76.8	0.016	1.483	1.302	0.031	
2441	39	Bluetooth	11.5	9.79	-0.080	10 mm [Left]	FCC #1	1	76.8	0.029	1.483	1.302	0.056	A60
ANSI / IEEE C95.1-1992- SAFETY LIMIT Spatial Peak Uncontrolled Exposure/General Population Exposure									Body 1.6 W/kg (mW/g) averaged over 1 gram					

Table 12.3.6 UNII Hotspot SAR

MEASUREMENT RESULTS															
FREQUENCY		Mode	Maximum Allowed Power [dBm]	Conducted Power [dBm]	Drift Power [dB]	Phantom Position	Device Serial Number	Peak SAR of Area Scan	Data Rate [Mbps]	Duty Cycle	1g SAR (W/kg)	Scaling Factor	Scaling Factor (Duty Cycle)	1g Scaled SAR (W/kg)	Plots #
MHz	Ch														
5240	48	802.11a (Ant.1)	16.0	15.65	0.120	10 mm [Top]	FCC #2	0.098	6	98.1	0.091	1.084	1.020	0.101	
5240	48	802.11a (Ant.1)	16.0	15.65	-0.070	10 mm [Front]	FCC #2	0.045	6	98.1	0.036	1.084	1.020	0.040	
5240	48	802.11a (Ant.1)	16.0	15.65	-0.020	10 mm [Rear]	FCC #2	0.444	6	98.1	0.481	1.084	1.020	0.532	A49
5240	48	802.11a (Ant.1)	16.0	15.65	0.040	10 mm [Left]	FCC #2	0.229	6	98.1	0.230	1.084	1.020	0.254	
5240	48	802.11a (Ant.2)	16.0	15.63	-0.140	10 mm [Top]	FCC #2	0.111	6	98.1	0.104	1.089	1.020	0.116	
5240	48	802.11a (Ant.2)	16.0	15.63	0.060	10 mm [Front]	FCC #2	0.070	6	98.1	0.052	1.089	1.020	0.058	
5240	48	802.11a (Ant.2)	16.0	15.63	-0.130	10 mm [Rear]	FCC #2	0.345	6	98.1	0.295	1.089	1.020	0.328	A50
5240	48	802.11a (Ant.2)	16.0	15.63	-0.140	10 mm [Left]	FCC #2	0.060	6	98.1	0.050	1.089	1.020	0.056	
5240	48	802.11a (MIMO)	19.0	18.65	-0.080	10 mm [Top]	FCC #2	0.191	6	98.1	0.188	1.089	1.020	0.209	
5240	48	802.11a (MIMO)	19.0	18.65	0.190	10 mm [Front]	FCC #2	0.086	6	98.1	0.080	1.089	1.020	0.089	
5240	48	802.11a (MIMO)	19.0	18.65	-0.030	10 mm [Rear]	FCC #2	0.540	6	98.1	0.528	1.089	1.020	0.586	A51
5240	48	802.11a (MIMO)	19.0	18.65	-0.080	10 mm [Left]	FCC #2	0.255	6	98.1	0.251	1.089	1.020	0.279	
ANSI / IEEE C95.1-1992- SAFETY LIMIT Spatial Peak Uncontrolled Exposure/General Population Exposure									Body 1.6 W/kg (mW/g) averaged over 1 gram						

Note(s):

- Highest reported SAR is ≤ 0.4 W/kg. Therefore, further SAR measurements within this exposure condition are not required.
- Highest reported SAR is > 0.4 W/kg. Due to the highest reported SAR for this test position, other test position is Head exposure condition were evaluated until a SAR ≤ 0.8 W/kg was reported.

Table 12.3.7 UNII Hotspot SAR

MEASUREMENT RESULTS

FREQUENCY		Mode	Maximum Allowed Power [dBm]	Conducted Power [dBm]	Drift Power [dB]	Phantom Position	Device Serial Number	Peak SAR of Area Scan	Data Rate [Mbps]	Duty Cycle	1g SAR (W/kg)	Scaling Factor	Scaling Factor (Duty Cycle)	1g Scaled SAR (W/kg)	Plots #
MHz	Ch														
5745	149	802.11a (Ant.1)	16.0	16.00	0.070	10 mm [Top]	FCC #2	0.073	6	98.1	0.059	1.000	1.020	0.060	
5745	149	802.11a (Ant.1)	16.0	16.00	-0.050	10 mm [Front]	FCC #2	0.074	6	98.1	0.069	1.000	1.020	0.070	
5745	149	802.11a (Ant.1)	16.0	16.00	-0.040	10 mm [Rear]	FCC #2	0.581	6	98.1	0.624	1.000	1.020	0.636	A42
5745	149	802.11a (Ant.1)	16.0	16.00	-0.030	10 mm [Left]	FCC #2	0.307	6	98.1	0.311	1.000	1.020	0.317	
5785	157	802.11a (Ant.2)	16.0	15.99	-0.050	10 mm [Top]	FCC #2	0.152	6	98.1	0.149	1.002	1.020	0.152	
5785	157	802.11a (Ant.2)	16.0	15.99	0.120	10 mm [Front]	FCC #2	0.023	6	98.1	0.016	1.002	1.020	0.016	
5785	157	802.11a (Ant.2)	16.0	15.99	0.050	10 mm [Rear]	FCC #2	0.186	6	98.1	0.177	1.002	1.020	0.181	A43
5785	157	802.11a (Ant.2)	16.0	15.99	-0.060	10 mm [Left]	FCC #2	0.026	6	98.1	0.016	1.002	1.020	0.016	
5745	149	802.11a (MIMO)	19.0	18.81	-0.150	10 mm [Top]	FCC #2	0.175	6	98.1	0.166	1.045	1.020	0.177	
5745	149	802.11a (MIMO)	19.0	18.81	-0.140	10 mm [Front]	FCC #2	0.078	6	98.1	0.070	1.045	1.020	0.075	
5745	149	802.11a (MIMO)	19.0	18.81	0.170	10 mm [Rear]	FCC #2	0.455	6	98.1	0.494	1.045	1.020	0.527	A44
5745	149	802.11a (MIMO)	19.0	18.81	-0.190	10 mm [Left]	FCC #2	0.314	6	98.1	0.317	1.045	1.020	0.338	
ANSI / IEEE C95.1-1992– SAFETY LIMIT Spatial Peak Uncontrolled Exposure/General Population Exposure								Body 1.6 W/kg (mW/g) averaged over 1 gram							

Note(s):

- Highest reported SAR is ≤ 0.4 W/kg. Therefore, further SAR measurements within this exposure condition are not required.
- Highest reported SAR is > 0.4 W/kg. Due to the highest reported SAR for this test position, other test position is Head exposure condition were evaluated until a SAR ≤ 0.8 W/kg was reported.

12.4 Standalone Phablet SAR Results

Per FCC KDB Publication 648474 D04 Handset SAR, Phablet SAR tests were not required of Hotspot 1g SAR scaled to maximum output power, including tolerance) < 1.2 W/kg.

Table 12.4.1 UNII Phablet SAR

MEASUREMENT RESULTS															
FREQUENCY		Mode	Maximum Allowed Power [dBm]	Conducted Power [dBm]	Drift Power [dB]	Phantom Position	Device Serial Number	Peak SAR of Area Scan	Data Rate [Mbps]	Duty Cycle	10g SAR (W/kg)	Scaling Factor	Scaling Factor (Duty Cycle)	10g Scaled SAR (W/kg)	Plots #
MHz	Ch														
5300	60	802.11a (Ant.1)	16.0	15.71	-0.140	0 mm [Top]	FCC #2	0.166	6	98.1	0.163	1.069	1.020	0.178	
5300	60	802.11a (Ant.1)	16.0	15.71	-0.180	0 mm [Front]	FCC #2	0.111	6	98.1	0.109	1.069	1.020	0.119	
5300	60	802.11a (Ant.1)	16.0	15.71	0.070	0 mm [Rear]	FCC #2	1.040	6	98.1	1.250	1.069	1.020	1.363	A52
5300	60	802.11a (Ant.1)	16.0	15.71	-0.170	0 mm [Left]	FCC #2	0.501	6	98.1	0.507	1.069	1.020	0.553	
5320	64	802.11a (Ant.2)	16.0	15.80	0.170	0 mm [Top]	FCC #2	0.366	6	98.1	0.378	1.047	1.020	0.404	
5320	64	802.11a (Ant.2)	16.0	15.80	0.000	0 mm [Front]	FCC #2	0.194	6	98.1	0.256	1.047	1.020	0.273	
5320	64	802.11a (Ant.2)	16.0	15.80	-0.140	0 mm [Rear]	FCC #2	0.812	6	98.1	0.793	1.047	1.020	0.847	A53
5320	64	802.11a (Ant.2)	16.0	15.80	-0.100	0 mm [Left]	FCC #2	0.110	6	98.1	0.101	1.047	1.020	0.108	
5300	60	802.11a (MIMO)	19.0	18.75	-0.010	0 mm [Top]	FCC #2	0.616	6	98.1	0.649	1.069	1.020	0.708	
5300	60	802.11a (MIMO)	19.0	18.75	-0.040	0 mm [Front]	FCC #2	0.362	6	98.1	0.424	1.069	1.020	0.462	
5300	60	802.11a (MIMO)	19.0	18.75	-0.050	0 mm [Rear]	FCC #2	2.070	6	98.1	2.040	1.069	1.020	2.224	A54
5320	64	802.11a (MIMO)	19.0	18.75	0.020	0 mm [Rear]	FCC #2	1.890	6	98.1	2.020	1.069	1.020	2.203	
5300	60	802.11a (MIMO)	19.0	18.75	0.050	0 mm [Left]	FCC #2	0.658	6	98.1	0.676	1.069	1.020	0.737	
5300	60	802.11a (MIMO)	19.0	18.75	0.000	0 mm [Rear]	FCC #2	1.870	6	98.1	1.820	1.069	1.020	1.984	
ANSI / IEEE C95.1-1992- SAFETY LIMIT Spatial Peak Uncontrolled Exposure/General Population Exposure								Hand 4.0 W/kg (mW/g) averaged over 10 gram							

Note(s):

- Highest reported SAR is ≤ 1.0 W/kg. Therefore, further SAR measurements within this exposure condition are not required.
- Highest reported SAR is > 1.0 W/kg. Due to the highest reported SAR for this test position, other test position is Head exposure condition were evaluated until a SAR ≤ 2.0 W/kg was reported.
- Highest reported SAR is > 2.0 W/kg. SAR is measured for these test positions/configurations on the subsequent next highest measured output power channel(s) until the reported SAR is ≤ 3.0 W/kg or all required channels are tested.
- Blue entries represent variability measurements.

Table 12.4.2 UNII Phablet SAR

MEASUREMENT RESULTS

FREQUENCY		Mode	Maximum Allowed Power [dBm]	Conducted Power [dBm]	Drift Power [dB]	Phantom Position	Device Serial Number	Peak SAR of Area Scan	Data Rate [Mbps]	Duty Cycle	10g SAR (W/kg)	Scaling Factor	Scaling Factor (Duty Cycle)	10g Scaled SAR (W/kg)	Plots #
MHz	Ch														
5720	144	802.11a (Ant.1)	16.0	15.88	0.090	0 mm [Top]	FCC #2	0.131	6	98.1	0.129	1.028	1.020	0.135	
5720	144	802.11a (Ant.1)	16.0	15.88	0.000	0 mm [Front]	FCC #2	0.130	6	98.1	0.133	1.028	1.020	0.139	
5720	144	802.11a (Ant.1)	16.0	15.88	0.070	0 mm [Rear]	FCC #2	0.957	6	98.1	1.200	1.028	1.020	1.258	A55
5720	144	802.11a (Ant.1)	16.0	15.88	0.010	0 mm [Left]	FCC #2	0.581	6	98.1	0.634	1.028	1.020	0.665	
5580	116	802.11a (Ant.2)	16.0	15.93	0.170	0 mm [Top]	FCC #2	0.221	6	98.1	0.230	1.016	1.020	0.238	
5580	116	802.11a (Ant.2)	16.0	15.93	-0.190	0 mm [Front]	FCC #2	0.107	6	98.1	0.124	1.016	1.020	0.129	
5580	116	802.11a (Ant.2)	16.0	15.93	-0.150	0 mm [Rear]	FCC #2	0.818	6	98.1	0.928	1.016	1.020	0.962	A56
5580	116	802.11a (Ant.2)	16.0	15.93	-0.090	0 mm [Left]	FCC #2	0.055	6	98.1	0.053	1.016	1.020	0.055	
5580	116	802.11a (MIMO)	19.0	18.86	-0.060	0 mm [Top]	FCC #2	0.428	6	98.1	0.461	1.033	1.020	0.486	
5580	116	802.11a (MIMO)	19.0	18.86	0.120	0 mm [Front]	FCC #2	0.251	6	98.1	0.253	1.033	1.020	0.267	
5580	116	802.11a (MIMO)	19.0	18.86	0.000	0 mm [Rear]	FCC #2	1.950	6	98.1	2.020	1.033	1.020	2.128	A57
5720	144	802.11a (MIMO)	19.0	18.77	0.000	0 mm [Rear]	FCC #2	1.340	6	98.1	1.960	1.054	1.020	2.107	
5580	116	802.11a (MIMO)	19.0	18.86	0.060	0 mm [Left]	FCC #2	0.683	6	98.1	0.736	1.033	1.020	0.775	
5580	116	802.11a (MIMO)	19.0	18.86	0.100	0 mm [Rear]	FCC #2	1.930	6	98.1	2.010	1.033	1.020	2.118	
ANSI / IEEE C95.1-1992– SAFETY LIMIT Spatial Peak Uncontrolled Exposure/General Population Exposure								Hand 4.0 W/kg (mW/g) averaged over 10 gram							

- Note(s):
- Highest reported SAR is ≤ 1.0 W/kg. Therefore, further SAR measurements within this exposure condition are not required.
 - Highest reported SAR is > 1.0 W/kg. Due to the highest reported SAR for this test position, other test position is Head exposure condition were evaluated until a SAR ≤ 2.0 W/kg was reported.
 - Highest reported SAR is > 2.0 W/kg. SAR is measured for these test positions/configurations on the subsequent next highest measured output power channel(s) until the reported SAR is ≤ 3.0 W/kg or all required channels are tested.
 - Blue entries represent variability measurements.

12.5 SAR Test Notes

General Notes:

1. The test data reported are the worst-case SAR values according to test procedures specified in IEEE 1528-2013, and FCC KDB Publication 447498 D01v06.
2. Batteries are fully charged at the beginning of the SAR measurements. A standard battery was used for all SAR measurements.
3. Liquid tissue depth was at least 15.0 cm for all frequencies.
4. The manufacturer has confirmed that the device(s) tested have the same physical, mechanical and thermal characteristics and are within operational tolerances expected for production units
5. SAR results were scaled to the maximum allowed power to demonstrate compliance per FCC KDB Publication 447498 D01v06.
6. Device was tested using a fixed spacing for body-worn accessory testing. A separation distance of 10 mm was considered because the manufacturer has determined that there will be body-worn accessories available in the marketplace for users to support this separation distance.
7. Per FCC KDB Publication 648474 D04v01r03, body-worn SAR was evaluated without a headset connected to the device. Since the standalone reported body-worn SAR was not > 1.2 W/kg, no additional body-worn SAR evaluations using a headset cable were performed.
8. Per FCC KDB 865664 D01v01r04, variability SAR tests were performed when the measured SAR results for a frequency band were greater than or equal to 0.8 W/kg. Repeated SAR measurements are highlighted in the tables above for clarity. Please see Section 14 for variability analysis.
9. During SAR Testing for the Wireless Router conditions per FCC KDB Publication 941225 D06v02r01, the actual Portable Hotspot operation (with actual simultaneous transmission of a transmitter with WIFI) was not activated.
10. SAR measurements were performed using the DASY5 automated system. The procedure for spatial peak SAR evaluation has been implemented according to the IEEE 1528 standard. During a maximum search, global and local maxima searches are automatically performed in 2-D after each area scan measurement. The algorithm will find the global maximum and all local maxima within 2 dB of the global maxima for all SAR distributions. All local maxima within 2 dB of the global maximum were searched and passed for the Zoom Scan measurement.

GSM Notes:

1. Body-Worn accessory testing is typically associated with voice operations. Therefore, GSM voice was evaluated for body-worn SAR.
2. This device supports GSM VOIP in the head and body-worn configurations; therefore GPRS was additionally evaluated for head and body-worn compliance.
3. Justification for reduced test configurations per KDB Publication 941225 D01v03r01 and October2013 TCB Workshop Notes: The source-based frame-averaged output power was evaluated for all GPRS/EDGE slot configurations. The configuration with the highest target frame averaged output power was evaluated for hotspot SAR.
4. Per FCC KDB Publication 447498 D01v06, if the reported (scaled) SAR measured at the middle channel or highest output power channel for each test configuration is ≤ 0.8 W/kg then testing at the other channels is not required for such test configuration(s). Since the maximum output power variation across the required test channels is not > $\frac{1}{2}$ dB, the middle channel was used for testing.

WCDMA (UMTS) Notes:

1. WCDMA (UMTS) mode in was tested under RMC 12.2 kbps with HSPA Inactive per KDB Publication 941225 D01v03r01. AMR and HSPA SAR was not required since the average output power of the HSPA subtests was not more than 0.25 dB higher than the RMC level and SAR was less than 1.2 W/kg.
2. Per FCC KDB Publication 447498 D01v06, if the reported (scaled) SAR measured at the middle channel or highest output power channel for each test configuration is ≤ 0.8 W/kg then testing at the other channels is not required for such test configuration(s). When the maximum output power variation across the required test channels is $> \frac{1}{2}$ dB, instead of the middle channel, the highest output power channel was used.

LTE Notes:

1. LTE Considerations: LTE test configurations are determined according to SAR Evaluation Considerations for LTE Devices in FCC KDB Publication 941225 D05v02r05. The general test procedures used for testing can be found in Section 5.
2. According to FCC KDB 941225 D05v02r05.
When the reported SAR is ≤ 0.8 W/kg, testing of the 100% RB allocation and required test channels is not required. Otherwise, SAR is required for the remaining required test channels using the 1 RB, 50% RB and 100% RB allocation with highest output power for that channel.
Only one channel, and as reported SAR values for 1 RB allocation and 50% RB allocation were less than 1.45 W/kg only the highest power RB offset for each allocation was required.
3. MPR is permanently implemented for this device by the manufacturer. The specific manufacturer target MPR is indicated alongside the SAR results. MPR is enabled for this device, according to 3GPP TS36. 101 Section 6.2.3 – 6.2.5 under Table 6.2.3-1.
4. A-MPR was disabled for all SAR tests by setting NS=1 on the base station simulator. SAR tests were performed with the same number of RB and RB offsets transmitting on all TTI frames (maximum TTI).
5. SAR test reduction is applied using the following criteria:
Start with the largest channel bandwidth and measure SAR for QPSK with 1 RB, and 50% RB allocation, using the RB offset and required test channel combination with the highest maximum output power among RB offsets at the upper edge, middle and lower edge of each required test channel. When the reported SAR is > 0.8 W/kg, testing for other channels is performed at the highest output power level for 1 RB, and 50% RB configuration for that channel. Testing for 100% RB configuration is performed at the highest output power level for 100% RB configuration across the Low, Mid and High channel when the highest reported SAR for 1 RB and 50% RB are > 0.8 W/kg, Testing for the remaining required channels is not needed because the reported SAR for 100% RB Allocation < 1.45 W/kg. Testing for 16QAM modulation is not required because the reported SAR for QPSK is < 1.45 W/kg and its output power is not more than 0.5 dB higher than that a QPSK. Testing for the other channel bandwidths is not required because the reported SAR for the highest channel bandwidth is < 1.45 W/kg and its output power is not more than 0.5 dB higher than that of the highest channel bandwidth.

WLAN Notes:

1. The initial test position procedures were applied. The test position with the highest extrapolated peak SAR will be used as the initial test position. When reported SAR for the initial test position is ≤ 0.4 W/kg, no additional testing for the remaining test positions was required. Otherwise, SAR is evaluated at the subsequent highest peak SAR positions until the reported SAR result is ≤ 0.8 W/kg or all test positions are measured.
2. Justification for test configurations for WLAN per KDB Publication 248227 D01v02r02 for 2.4 GHz WIFI single transmission chain operations, the highest measured maximum output power channel for DSSS was selected for SAR measurement. SAR for OFDM modes (2.4 GHz 802.11g/n) was not required due to the maximum allowed powers and the highest reported DSSS SAR when the highest reported SAR for DSSS is adjusted by the ratio of OFDM to DSSS specified maximum output and the adjusted SAR is ≤ 1.2 W/kg.
3. Justification for test configurations for WLAN per KDB Publication 248227 D01v02r02 for 5 GHz WIFI single transmission chain operations, the initial test configuration was selected according to the transmission mode with the highest maximum allowed powers. Other transmission modes were not investigated since the highest reported SAR for initial test configuration adjusted by the ratio of maximum output powers is less than 1.2 W/kg.
4. When the maximum reported 1g averaged SAR ≤ 0.8 W/kg, SAR testing on additional channels was not required. Otherwise, SAR for the next highest output power channel was required until the reported SAR result was ≤ 1.20 W/kg or all test channels were measured.
5. The device was configured to transmit continuously at the required data rate, channel bandwidth and signal modulation, using the highest transmission duty factor to determine compliance.
6. Per KDB Publication 248227 D01v02r02, SAR for MIMO was evaluated by following the simultaneous SAR provisions from KDB Publication 447498 D01v06.

Bluetooth Notes:

1. Bluetooth SAR was measured with the device connected to a call with hopping disabled with DH5 operation. Per October 2016 TCB Workshop Notes, the reported SAR was scaled to the 100% transmission duty factor to determine compliance. Refer to section 10.5 for the time-domain plot and calculation for the duty factor of the device.

13. FCC MULTI-TX AND ANTENNA SAR CONSIDERATIONS

13.1 Introduction

The following procedures adopted from FCC KDB Publication 447498 D01v06 are applicable to handsets with built-in unlicensed transmitters such as 802.11 and Bluetooth devices which may simultaneously transmit with the licensed transmitter.

13.2 Simultaneous Transmission Procedures

This device contains transmitters that may operate simultaneously. Therefore simultaneous transmission analysis is required. Per FCC KDB 447498 D01v06 4.3.2 and IEEE 1528-2013 Section 6.3.4.1.2, simultaneous transmission SAR test exclusion may be applied when the sum of the sum 1-g SAR for all the simultaneous transmitting antennas in a specific a physical test configuration is ≤ 1.6 W/kg. The different test position in an exposure condition may be considered collectively to determine SAR test exclusion according to the sum of 1-g or 10-g SAR.

13.3 Simultaneous Transmission Capabilities

According to FCC KDB Publication 447498 D01v06, transmitters are considered to be transmitting simultaneously when there is overlapping transmission, with the exception of transmissions during network hand-offs with maximum hand-off duration less than 30 seconds. Possible transmission paths for the DUT are shown in Figure 13.1 and are color-coded to indicate communication modes which share the same path. Modes which share the same transmission path cannot transmit simultaneously with one another.

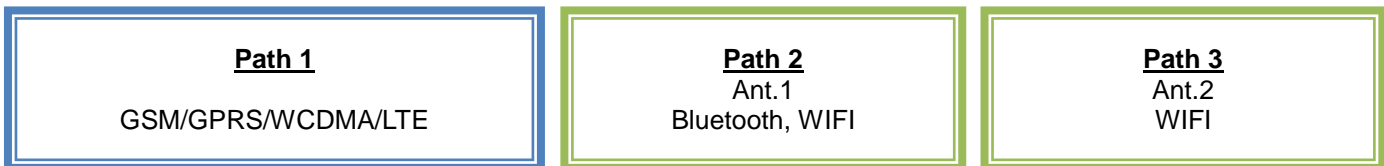

Figure 13.1 Simultaneous Transmission Paths

This device contains multiple transmitters that may operate simultaneously, and therefore requires a simultaneous transmission analysis according to FCC KDB Publication 447498 D01v06.

Table 13.3.1 Simultaneous Transmission Scenarios

No.	Capable TX Configuration	GSM850/1900 voice	GPRS/EDGE 850/1900	WCDMA 850/1700/1900 Voice	WCDMA 850/1700/1900 data(HSDPA,HSUPA)	LTE B17,B13,B5	WIFI 2.4GHz 802.11b/g/n/ac	WIFI 5GHz 802.11a/n/ac	Bluetooth 2.4GHz
1	GSM850/1900 voice		No	No	No	No	Yes	Yes	Yes
2	GPRS/EDGE 850/1900	No		No	No	No	Yes	Yes	Yes
3	WCDMA 850/1700/1900 Voice	No	No		No	No	Yes	Yes	Yes
4	WCDMA 850/1700/1900 data(HSDPA,HSUPA)	No	No	No		No	Yes	Yes	Yes
5	LTE B17,B13,B5	No	No	No	No		Yes	Yes	Yes
6	WIFI 2.4GHz 802.11b/g/n/ac	Yes	Yes	Yes	Yes	Yes		Yes	No
7	WIFI 5GHz 802.11a/n/ac	Yes	Yes	Yes	Yes	Yes	Yes		Yes
8	Bluetooth 2.4GHz	Yes	Yes	Yes	Yes	Yes	No	Yes	

Table 13.3.2 Simultaneous SAR Cases

No.	Capable Transmit Configuration	Head SAR	Body-Worn SAR	Hotspot SAR	Note
1	GSM Voice + Wi-Fi 2.4 GHz	Yes	Yes	N/A	
2	GSM Voice + Wi-Fi 5 GHz	Yes	Yes	N/A	
3	GSM Voice + Bluetooth 2.4 GHz	Yes	Yes	N/A	
4	GSM Voice + Wi-Fi 2.4 GHz MIMO	Yes	Yes	N/A	
5	GSM Voice + Wi-Fi 5 GHz MIMO	Yes	Yes	N/A	
6	GSM Voice + Wi-Fi 2.4 GHz + Wi-Fi 5GHz	Yes	Yes	N/A	
7	GSM Voice + Bluetooth 2.4 GHz + Wi-Fi 5GHz SISO	Yes	Yes	N/A	
8	GSM Voice + Bluetooth 2.4 GHz + Wi-Fi 5GHz MIMO	Yes	Yes	N/A	
9	WCDMA + Wi-Fi 2.4 GHz	Yes	Yes	Yes	
10	WCDMA + Wi-Fi 5 GHz	Yes	Yes	Yes	
11	WCDMA + Bluetooth 2.4 GHz	Yes	Yes	Yes	
12	WCDMA + Wi-Fi 2.4 GHz MIMO	Yes	Yes	Yes	
13	WCDMA + Wi-Fi 5 GHz MIMO	Yes	Yes	Yes	
14	WCDMA + Wi-Fi 2.4 GHz + Wi-Fi 5GHz	Yes	Yes	Yes	
15	WCDMA + Bluetooth 2.4 GHz + Wi-Fi 5GHz SISO	Yes	Yes	Yes	
16	WCDMA + Bluetooth 2.4 GHz + Wi-Fi 5GHz MIMO	Yes	Yes	Yes	
17	LTE + Wi-Fi 2.4 GHz	Yes	Yes	Yes	
18	LTE + Wi-Fi 5 GHz	Yes	Yes	Yes	
19	LTE + Bluetooth 2.4 GHz	Yes	Yes	Yes	
20	LTE + Wi-Fi 2.4 GHz MIMO	Yes	Yes	Yes	
21	LTE + Wi-Fi 5 GHz MIMO	Yes	Yes	Yes	
22	LTE + Wi-Fi 2.4 GHz + Wi-Fi 5GHz	Yes	Yes	Yes	
23	LTE + Bluetooth 2.4 GHz + Wi-Fi 5GHz SISO	Yes	Yes	Yes	
24	LTE + Bluetooth 2.4 GHz + Wi-Fi 5GHz MIMO	Yes	Yes	Yes	
25	GPRS/EDGE + Wi-Fi 2.4 GHz	Yes	Yes *	Yes	* Pre-installed VOIP applications are considered
26	GPRS/EDGE + Wi-Fi 5 GHz	Yes	Yes *	Yes	* Pre-installed VOIP applications are considered
27	GPRS/EDGE + Bluetooth 2.4 GHz	Yes	Yes *	Yes	* Pre-installed VOIP applications are considered
28	GPRS/EDGE + Wi-Fi 2.4 GHz MIMO	Yes	Yes *	Yes	* Pre-installed VOIP applications are considered
29	GPRS/EDGE + Wi-Fi 5 GHz MIMO	Yes	Yes *	Yes	* Pre-installed VOIP applications are considered
30	GPRS/EDGE + Wi-Fi 2.4 GHz + Wi-Fi 5GHz	Yes	Yes *	Yes	* Pre-installed VOIP applications are considered
31	GPRS/EDGE + Bluetooth 2.4 GHz + Wi-Fi 5GHz SISO	Yes	Yes *	Yes	* Pre-installed VOIP applications are considered
32	GPRS/EDGE + Bluetooth 2.4 GHz + Wi-Fi 5GHz MIMO	Yes	Yes *	Yes	* Pre-installed VOIP applications are considered

Notes:

1. Wi-Fi 2.4GHz is supported Hotspot and Wi-Fi-Direct(GO/GC).
2. Wi-Fi 5GHz is supported Hotspot in UNII B1,B3 and Wi-Fi-Direct(GO/GC) in UNII B1,B3.
3. Wi-Fi 2.4GHz and 5GHz are supported in the same time(DBS)
4. LTE, WCDMA, GPRS/EDGE is supported Hotspot.
5. VoIP is supported in LTE, WCDMA, GSM
6. Bluetooth and Wi-Fi can not transmit simultaneously at 2.4G band.
7. GSM, WCDMA and LTE can not transmit simultaneously since they share the same chip.
8. When the user utilizes multiple services in UMTS 3G mode it uses multi-Radio Access Bearer or multi-RAB. The power control is based on a physical control channel (Dedicated Physical Control Channel [DPCCH]) and power control will be adjusted to meet the needs of both services. Therefore, the UMTS+WLAN scenario also represents the UMTS Voice/DATA + WLAN Hotspot scenario.
9. Per the manufacturer, Wi-Fi Direct is not expected to be used in conjunction with a held-to-ear or body-worn accessory voice call. Therefore, there are no simultaneous transmission scenarios involving Wi-Fi direct beyond that listed in the above table.

13.4 Head SAR Simultaneous Transmission Analysis

All simultaneous cases were investigated and the worst case simultaneous results are reported for each band/mode/configuration.

Table 13.4.1 Simultaneous Transmission Scenario for 2G/3G/4G with 2.4 GHz W-LAN (Held to Ear)

Exposure Condition	Mode	2G/3G/4G SAR (W/kg)	2.4G W-LAN Ant.1 SAR (W/kg)	Σ SAR (W/kg)
		1	2	1+2
Head SAR	GSM 850	0.109	0.484	0.593
	GPRS 850	0.136	0.484	0.620
	GSM 1900	0.150	0.484	0.634
	GPRS 1900	0.205	0.484	0.689
	WCDMA 850	0.161	0.484	0.645
	WCDMA 1700	0.143	0.484	0.627
	WCDMA 1900	0.181	0.484	0.665
	LTE Band 17	0.082	0.484	0.566
	LTE Band 13	0.046	0.484	0.530
LTE Band 5	0.148	0.484	0.632	

Simul Tx	Configuration	GPRS 1900 SAR (W/kg)	2.4G W-LAN Ant.1 SAR (W/kg)	Σ SAR (W/kg)
		1	2	1+2
Head SAR	Left Touch	0.227	0.110	0.337
	Right Touch	0.205	0.484	0.689
	Left Tilt	0.194	0.062	0.256
	Right Tilt	0.140	0.234	0.374

Note : The above simultaneous result is the worst case result for 2G/3G/4G + 2.4G WLAN Ant1 simultaneous case for held to ear.

Table 13.4.2 Simultaneous Transmission Scenario for 2G/3G/4G with 2.4 GHz W-LAN (Held to Ear)

Exposure Condition	Mode	2G/3G/4G SAR (W/kg)	2.4G W-LAN Ant.2 SAR (W/kg)	Σ SAR (W/kg)
		1	2	1+2
Head SAR	GSM 850	0.109	0.629	0.738
	GPRS 850	0.136	0.629	0.765
	GSM 1900	0.150	0.629	0.779
	GPRS 1900	0.205	0.629	0.834
	WCDMA 850	0.161	0.629	0.790
	WCDMA 1700	0.143	0.629	0.772
	WCDMA 1900	0.181	0.629	0.810
	LTE Band 17	0.087	0.649	0.736
	LTE Band 13	0.035	0.649	0.684
	LTE Band 5	0.148	0.629	0.777

Simul Tx	Configuration	GPRS 1900 SAR (W/kg)	2.4G W-LAN Ant.2 SAR (W/kg)	Σ SAR (W/kg)
		1	2	1+2
Head SAR	Left Touch	0.227	0.298	0.525
	Right Touch	0.205	0.629	0.834
	Left Tilt	0.194	0.415	0.609
	Right Tilt	0.140	0.649	0.789

Note : The above simultaneous result is the worst case result for 2G/3G/4G + 2.4G WLAN Ant2 simultaneous case for held to ear.

Table 13.4.3 Simultaneous Transmission Scenario for 2G/3G/4G with 2.4 GHz W-LAN (Held to Ear)

Exposure Condition	Mode	2G/3G/4G SAR (W/kg)	2.4G W-LAN MIMO SAR (W/kg)	Σ SAR (W/kg)
		1	2	1+2
Head SAR	GSM 850	0.109	0.903	1.012
	GPRS 850	0.136	0.903	1.039
	GSM 1900	0.150	0.903	1.053
	GPRS 1900	0.205	0.903	1.108
	WCDMA 850	0.161	0.903	1.064
	WCDMA 1700	0.143	0.903	1.046
	WCDMA 1900	0.181	0.903	1.084
	LTE Band 17	0.082	0.903	0.985
	LTE Band 13	0.046	0.903	0.949
	LTE Band 5	0.148	0.903	1.051

Simul Tx	Configuration	GPRS 1900 SAR (W/kg)	2.4G W-LAN MIMO SAR (W/kg)	Σ SAR (W/kg)
		1	2	1+2
Head SAR	Left Touch	0.227	0.366	0.593
	Right Touch	0.205	0.903	1.108
	Left Tilt	0.194	0.498	0.692
	Right Tilt	0.140	0.758	0.898

Note : The above simultaneous result is the worst case result for 2G/3G/4G + 2.4G WLAN MIMO simultaneous case for held to ear.

Table 13.4.4 Simultaneous Transmission Scenario for 2G/3G/4G with 5.3 GHz W-LAN (Held to Ear)

Exposure Condition	Mode	2G/3G/4G SAR (W/kg)	5.3G W-LAN Ant.1 SAR (W/kg)	Σ SAR (W/kg)
		1	2	1+2
Head SAR	GSM 850	0.109	0.176	0.285
	GPRS 850	0.251	0.064	0.315
	GSM 1900	0.150	0.176	0.326
	GPRS 1900	0.205	0.176	0.381
	WCDMA 850	0.161	0.176	0.337
	WCDMA 1700	0.143	0.176	0.319
	WCDMA 1900	0.181	0.176	0.357
	LTE Band 17	0.082	0.176	0.258
	LTE Band 13	0.046	0.176	0.222
	LTE Band 5	0.148	0.176	0.324

Simul Tx	Configuration	GPRS 1900 SAR (W/kg)	5.3G W-LAN Ant.1 SAR (W/kg)	Σ SAR (W/kg)
		1	2	1+2
Head SAR	Left Touch	0.227	0.064	0.291
	Right Touch	0.205	0.176	0.381
	Left Tilt	0.194	0.060	0.254
	Right Tilt	0.140	0.157	0.297

Note : The above simultaneous result is the worst case result for 2G/3G/4G + 5.3G WLAN Ant1 simultaneous case for held to ear.

Table 13.4.5 Simultaneous Transmission Scenario for 2G/3G/4G with 5.3 GHz W-LAN (Held to Ear)

Exposure Condition	Mode	2G/3G/4G SAR (W/kg)	5.3G W-LAN Ant.2 SAR (W/kg)	Σ SAR (W/kg)
		1	2	1+2
Head SAR	GSM 850	0.073	0.688	0.761
	GPRS 850	0.089	0.688	0.777
	GSM 1900	0.103	0.688	0.791
	GPRS 1900	0.140	0.688	0.828
	WCDMA 850	0.113	0.688	0.801
	WCDMA 1700	0.097	0.688	0.785
	WCDMA 1900	0.113	0.688	0.801
	LTE Band 17	0.087	0.688	0.775
	LTE Band 13	0.035	0.688	0.723
	LTE Band 5	0.127	0.688	0.815

Simul Tx	Configuration	GPRS 1900 SAR (W/kg)	5.3G W-LAN Ant.2 SAR (W/kg)	Σ SAR (W/kg)
		1	2	1+2
Head SAR	Left Touch	0.227	0.239	0.466
	Right Touch	0.205	0.586	0.791
	Left Tilt	0.194	0.289	0.483
	Right Tilt	0.140	0.688	0.828

Note : The above simultaneous result is the worst case result for 2G/3G/4G + 5.3G WLAN Ant2 simultaneous case for held to ear.

Table 13.4.6 Simultaneous Transmission Scenario for 2G/3G/4G with 5.3 GHz W-LAN (Held to Ear)

Exposure Condition	Mode	2G/3G/4G SAR (W/kg)	5.3G W-LAN MIMO SAR (W/kg)	Σ SAR (W/kg)
		1	2	1+2
Head SAR	GSM 850	0.073	0.948	1.021
	GPRS 850	0.089	0.948	1.037
	GSM 1900	0.103	0.948	1.051
	GPRS 1900	0.140	0.948	1.088
	WCDMA 850	0.113	0.948	1.061
	WCDMA 1700	0.097	0.948	1.045
	WCDMA 1900	0.113	0.948	1.061
	LTE Band 17	0.087	0.948	1.035
	LTE Band 13	0.035	0.948	0.983
	LTE Band 5	0.127	0.948	1.075

Simul Tx	Configuration	GPRS 1900 SAR (W/kg)	5.3G W-LAN MIMO SAR (W/kg)	Σ SAR (W/kg)
		1	2	1+2
Head SAR	Left Touch	0.227	0.314	0.541
	Right Touch	0.205	0.785	0.990
	Left Tilt	0.194	0.415	0.609
	Right Tilt	0.140	0.948	1.088

Note : The above simultaneous result is the worst case result for 2G/3G/4G + 5.3G WLAN MIMO simultaneous case for held to ear.

Table 13.4.7 Simultaneous Transmission Scenario for 2G/3G/4G with 5.6 GHz W-LAN (Held to Ear)

Exposure Condition	Mode	2G/3G/4G SAR (W/kg)	5.6G W-LAN Ant.1 SAR (W/kg)	Σ SAR (W/kg)
		1	2	1+2
Head SAR	GSM 850	0.109	0.275	0.384
	GPRS 850	0.136	0.275	0.411
	GSM 1900	0.150	0.275	0.425
	GPRS 1900	0.205	0.275	0.480
	WCDMA 850	0.161	0.275	0.436
	WCDMA 1700	0.143	0.275	0.418
	WCDMA 1900	0.181	0.275	0.456
	LTE Band 17	0.082	0.275	0.357
	LTE Band 13	0.046	0.275	0.321
	LTE Band 5	0.148	0.275	0.423

Simul Tx	Configuration	GPRS 1900 SAR (W/kg)	5.6G W-LAN Ant.1 SAR (W/kg)	Σ SAR (W/kg)
		1	2	1+2
Head SAR	Left Touch	0.227	0.069	0.296
	Right Touch	0.205	0.275	0.480
	Left Tilt	0.194	0.101	0.295
	Right Tilt	0.140	0.216	0.356

Note : The above simultaneous result is the worst case result for 2G/3G/4G + 5.6G WLAN Ant1 simultaneous case for held to ear.

Table 13.4.8 Simultaneous Transmission Scenario for 2G/3G/4G with 5.6 GHz W-LAN (Held to Ear)

Exposure Condition	Mode	2G/3G/4G SAR (W/kg)	5.6G W-LAN Ant.2 SAR (W/kg)	Σ SAR (W/kg)
		1	2	1+2
Head SAR	GSM 850	0.195	0.110	0.305
	GPRS 850	0.251	0.110	0.361
	GSM 1900	0.150	0.183	0.333
	GPRS 1900	0.205	0.183	0.388
	WCDMA 850	0.254	0.110	0.364
	WCDMA 1700	0.143	0.183	0.326
	WCDMA 1900	0.181	0.183	0.364
	LTE Band 17	0.087	0.207	0.294
	LTE Band 13	0.035	0.207	0.242
	LTE Band 5	0.127	0.207	0.334

Simul Tx	Configuration	GPRS 1900 SAR (W/kg)	5.6G W-LAN Ant.2 SAR (W/kg)	Σ SAR (W/kg)
		1	2	1+2
Head SAR	Left Touch	0.227	0.11	0.337
	Right Touch	0.205	0.183	0.388
	Left Tilt	0.194	0.154	0.348
	Right Tilt	0.140	0.207	0.347

Note : The above simultaneous result is the worst case result for 2G/3G/4G + 5.6G WLAN Ant2 simultaneous case for held to ear.

Table 13.4.9 Simultaneous Transmission Scenario for 2G/3G/4G with 5.6 GHz W-LAN (Held to Ear)

Exposure Condition	Mode	2G/3G/4G SAR (W/kg)	5.6G W-LAN MIMO SAR (W/kg)	Σ SAR (W/kg)
		1	2	1+2
Head SAR	GSM 850	0.073	0.607	0.680
	GPRS 850	0.089	0.607	0.696
	GSM 1900	0.103	0.607	0.710
	GPRS 1900	0.140	0.607	0.747
	WCDMA 850	0.113	0.607	0.720
	WCDMA 1700	0.097	0.607	0.704
	WCDMA 1900	0.113	0.607	0.720
	LTE Band 17	0.087	0.607	0.694
	LTE Band 13	0.035	0.607	0.642
	LTE Band 5	0.127	0.607	0.734

Simul Tx	Configuration	GPRS 1900 SAR (W/kg)	5.6G W-LAN MIMO SAR (W/kg)	Σ SAR (W/kg)
		1	2	1+2
Head SAR	Left Touch	0.227	0.214	0.441
	Right Touch	0.205	0.525	0.730
	Left Tilt	0.194	0.224	0.418
	Right Tilt	0.140	0.607	0.747

Note : The above simultaneous result is the worst case result for 2G/3G/4G + 5.6G WLAN MIMO simultaneous case for held to ear.

Table 13.4.10 Simultaneous Transmission Scenario for 2G/3G/4G with 5.8 GHz W-LAN (Held to Ear)

Exposure Condition	Mode	2G/3G/4G SAR (W/kg)	5.8G W-LAN Ant.1 SAR (W/kg)	Σ SAR (W/kg)
		1	2	1+2
Head SAR	GSM 850	0.109	0.384	0.493
	GPRS 850	0.136	0.384	0.520
	GSM 1900	0.150	0.384	0.534
	GPRS 1900	0.205	0.384	0.589
	WCDMA 850	0.161	0.384	0.545
	WCDMA 1700	0.143	0.384	0.527
	WCDMA 1900	0.181	0.384	0.565
	LTE Band 17	0.082	0.384	0.466
	LTE Band 13	0.046	0.384	0.430
	LTE Band 5	0.148	0.384	0.532

Simul Tx	Configuration	GPRS 1900 SAR (W/kg)	5.8G W-LAN Ant.1 SAR (W/kg)	Σ SAR (W/kg)
		1	2	1+2
Head SAR	Left Touch	0.227	0.081	0.308
	Right Touch	0.205	0.384	0.589
	Left Tilt	0.194	0.079	0.273
	Right Tilt	0.140	0.198	0.338

Note : The above simultaneous result is the worst case result for 2G/3G/4G + 5.8G WLAN Ant1 simultaneous case for held to ear.

Table 13.4.11 Simultaneous Transmission Scenario for 2G/3G/4G with 5.8 GHz W-LAN (Held to Ear)

Exposure Condition	Mode	2G/3G/4G SAR (W/kg)	5.8G W-LAN Ant.2 SAR (W/kg)	Σ SAR (W/kg)
		1	2	1+2
Head SAR	GSM 850	0.195	0.095	0.290
	GPRS 850	0.251	0.095	0.346
	GSM 1900	0.150	0.165	0.315
	GPRS 1900	0.205	0.165	0.370
	WCDMA 850	0.254	0.095	0.349
	WCDMA 1700	0.143	0.165	0.308
	WCDMA 1900	0.181	0.165	0.346
	LTE Band 17	0.087	0.176	0.263
	LTE Band 13	0.046	0.165	0.211
	LTE Band 5	0.221	0.095	0.316

Simul Tx	Configuration	GPRS 1900 SAR (W/kg)	5.8G W-LAN Ant.2 SAR (W/kg)	Σ SAR (W/kg)
		1	2	1+2
Head SAR	Left Touch	0.227	0.095	0.322
	Right Touch	0.205	0.165	0.370
	Left Tilt	0.194	0.120	0.314
	Right Tilt	0.140	0.176	0.316

Note : The above simultaneous result is the worst case result for 2G/3G/4G + 5.8G WLAN Ant2 simultaneous case for held to ear.

Table 13.4.12 Simultaneous Transmission Scenario for 2G/3G/4G with 5.8 GHz W-LAN (Held to Ear)

Exposure Condition	Mode	2G/3G/4G SAR (W/kg)	5.8G W-LAN MIMO SAR (W/kg)	Σ SAR (W/kg)
		1	2	1+2
Head SAR	GSM 850	0.109	0.555	0.664
	GPRS 850	0.136	0.555	0.691
	GSM 1900	0.150	0.555	0.705
	GPRS 1900	0.205	0.555	0.760
	WCDMA 850	0.161	0.555	0.716
	WCDMA 1700	0.143	0.555	0.698
	WCDMA 1900	0.181	0.555	0.736
	LTE Band 17	0.082	0.555	0.637
	LTE Band 13	0.046	0.555	0.601
	LTE Band 5	0.148	0.555	0.703

Simul Tx	Configuration	GPRS 1900 SAR (W/kg)	5.8G W-LAN MIMO SAR (W/kg)	Σ SAR (W/kg)
		1	2	1+2
Head SAR	Left Touch	0.227	0.148	0.375
	Right Touch	0.205	0.555	0.760
	Left Tilt	0.194	0.194	0.388
	Right Tilt	0.140	0.401	0.541

Note : The above simultaneous result is the worst case result for 2G/3G/4G + 5.8G WLAN MIMO simultaneous case for held to ear.

Table 13.4.13 Simultaneous Transmission Scenario for 2G/3G/4G with 2.4 GHz Ant.1 and 5.3 GHz Ant.2 W-LAN (Held to Ear)

Exposure Condition	Mode	2G/3G/4G SAR (W/kg)	2.4G W-LAN Ant.1 SAR (W/kg)	5.3G W-LAN Ant.2 SAR (W/kg)	ΣSAR (W/kg)		
		1	2	3	1+2	1+3	1+2+3
Head SAR	GSM 850	0.109	0.484	0.586	0.593	0.695	1.179
	GPRS 850	0.136	0.484	0.586	0.620	0.722	1.206
	GSM 1900	0.150	0.484	0.586	0.634	0.736	1.220
	GPRS 1900	0.205	0.484	0.586	0.689	0.791	1.275
	WCDMA 850	0.161	0.484	0.586	0.645	0.747	1.231
	WCDMA 1700	0.143	0.484	0.586	0.627	0.729	1.213
	WCDMA 1900	0.181	0.484	0.586	0.665	0.767	1.251
	LTE Band 17	0.082	0.484	0.586	0.566	0.668	1.152
	LTE Band 13	0.046	0.484	0.586	0.530	0.632	1.116
	LTE Band 5	0.148	0.484	0.586	0.632	0.734	1.218

Simul Tx	Configuration	GPRS 1900 SAR (W/kg)	2.4G W-LAN Ant.1 SAR (W/kg)	5.3G W-LAN Ant.2 SAR (W/kg)	ΣSAR (W/kg)		
		1	2	3	1+2	1+3	1+2+3
Head SAR	Left Touch	0.227	0.110	0.239	0.337	0.466	0.576
	Right Touch	0.205	0.484	0.586	0.689	0.791	1.275
	Left Tilt	0.194	0.062	0.289	0.256	0.483	0.545
	Right Tilt	0.140	0.234	0.688	0.374	0.828	1.062

Note : The above simultaneous result is the worst case result for 2G/3G/4G + 2.4G WLAN Ant1 + 5.3G WLAN Ant2 simultaneous case for held to ear.

Table 13.4.14 Simultaneous Transmission Scenario for 2G/3G/4G with 2.4 GHz Ant.1 and 5.6 GHz Ant.2 W-LAN (Held to Ear)

Exposure Condition	Mode	2G/3G/4G SAR (W/kg)	2.4G W-LAN Ant.1 SAR (W/kg)	5.6G W-LAN Ant.2 SAR (W/kg)	ΣSAR (W/kg)		
		1	2	3	1+2	1+3	1+2+3
Head SAR	GSM 850	0.109	0.484	0.183	0.593	0.292	0.776
	GPRS 850	0.136	0.484	0.183	0.620	0.319	0.803
	GSM 1900	0.150	0.484	0.183	0.634	0.333	0.817
	GPRS 1900	0.205	0.484	0.183	0.689	0.388	0.872
	WCDMA 850	0.161	0.484	0.183	0.645	0.344	0.828
	WCDMA 1700	0.143	0.484	0.183	0.627	0.326	0.810
	WCDMA 1900	0.181	0.484	0.183	0.665	0.364	0.848
	LTE Band 17	0.082	0.484	0.183	0.566	0.265	0.749
	LTE Band 13	0.046	0.484	0.183	0.530	0.229	0.713
	LTE Band 5	0.148	0.484	0.183	0.632	0.331	0.815

Simul Tx	Configuration	GPRS 1900 SAR (W/kg)	2.4G W-LAN Ant.1 SAR (W/kg)	5.6G W-LAN Ant.2 SAR (W/kg)	ΣSAR (W/kg)		
		1	2	3	1+2	1+3	1+2+3
Head SAR	Left Touch	0.227	0.110	0.110	0.337	0.337	0.447
	Right Touch	0.205	0.484	0.183	0.689	0.388	0.872
	Left Tilt	0.194	0.062	0.154	0.256	0.348	0.410
	Right Tilt	0.140	0.234	0.207	0.374	0.347	0.581

Note : The above simultaneous result is the worst case result for 2G/3G/4G + 2.4G WLAN Ant1 + 5.6G WLAN Ant2 simultaneous case for held to ear.

Table 13.4.15 Simultaneous Transmission Scenario for 2G/3G/4G with 2.4 GHz Ant.1 and 5.8 GHz Ant.2 W-LAN (Held to Ear)

Exposure Condition	Mode	2G/3G/4G SAR (W/kg)	2.4G W-LAN Ant.1 SAR (W/kg)	5.8G W-LAN Ant.2 SAR (W/kg)	ΣSAR (W/kg)		
		1	2	3	1+2	1+3	1+2+3
Head SAR	GSM 850	0.109	0.484	0.165	0.593	0.274	0.758
	GPRS 850	0.136	0.484	0.165	0.620	0.301	0.785
	GSM 1900	0.150	0.484	0.165	0.634	0.315	0.799
	GPRS 1900	0.205	0.484	0.165	0.689	0.370	0.854
	WCDMA 850	0.161	0.484	0.165	0.645	0.326	0.810
	WCDMA 1700	0.143	0.484	0.165	0.627	0.308	0.792
	WCDMA 1900	0.181	0.484	0.165	0.665	0.346	0.830
	LTE Band 17	0.082	0.484	0.165	0.566	0.247	0.731
	LTE Band 13	0.046	0.484	0.165	0.530	0.211	0.695
	LTE Band 5	0.148	0.484	0.165	0.632	0.313	0.797

Simul Tx	Configuration	GPRS 1900 SAR (W/kg)	2.4G W-LAN Ant.1 SAR (W/kg)	5.8G W-LAN Ant.2 SAR (W/kg)	ΣSAR (W/kg)		
		1	2	3	1+2	1+3	1+2+3
Head SAR	Left Touch	0.227	0.110	0.095	0.337	0.322	0.432
	Right Touch	0.205	0.484	0.165	0.689	0.370	0.854
	Left Tilt	0.194	0.062	0.120	0.256	0.314	0.376
	Right Tilt	0.140	0.234	0.176	0.374	0.316	0.550

Note : The above simultaneous result is the worst case result for 2G/3G/4G + 2.4G WLAN Ant1 + 5.8G WLAN Ant2 simultaneous case for held to ear.

Table 13.4.16 Simultaneous Transmission Scenario for 2G/3G/4G with Bluetooth Ant.1 and 5.3 GHz Ant.1 W-LAN (Held to Ear)

Exposure Condition	Mode	2G/3G/4G SAR (W/kg)	Bluetooth Ant.1 SAR (W/kg)	5.3G W-LAN Ant.1 SAR (W/kg)	ΣSAR (W/kg)		
		1	2	3	1+2	1+3	1+2+3
Head SAR	GSM 850	0.109	0.228	0.176	0.337	0.285	0.513
	GPRS 850	0.136	0.228	0.176	0.364	0.312	0.540
	GSM 1900	0.150	0.228	0.176	0.378	0.326	0.554
	GPRS 1900	0.205	0.228	0.176	0.433	0.381	0.609
	WCDMA 850	0.161	0.228	0.176	0.389	0.337	0.565
	WCDMA 1700	0.143	0.228	0.176	0.371	0.319	0.547
	WCDMA 1900	0.181	0.228	0.176	0.409	0.357	0.585
	LTE Band 17	0.082	0.228	0.176	0.31	0.258	0.486
	LTE Band 13	0.046	0.228	0.176	0.274	0.222	0.450
	LTE Band 5	0.148	0.228	0.176	0.376	0.324	0.552

Simul Tx	Configuration	GPRS 1900 SAR (W/kg)	Bluetooth Ant.1 SAR (W/kg)	5.3G W-LAN Ant.1 SAR (W/kg)	ΣSAR (W/kg)		
		1	2	3	1+2	1+3	1+2+3
Head SAR	Left Touch	0.227	0.035	0.064	0.262	0.291	0.326
	Right Touch	0.205	0.228	0.176	0.433	0.381	0.609
	Left Tilt	0.194	0.019	0.060	0.213	0.254	0.273
	Right Tilt	0.140	0.081	0.157	0.221	0.297	0.378

Note : The above simultaneous result is the worst case result for 2G/3G/4G + Bluetooth Ant1 + 5.3G WLAN Ant1 simultaneous case for held to ear.

Table 13.4.17 Simultaneous Transmission Scenario for 2G/3G/4G with Bluetooth Ant.1 and 5.6 GHz Ant.1 W-LAN (Held to Ear)

Exposure Condition	Mode	2G/3G/4G SAR (W/kg)	Bluetooth Ant.1 SAR (W/kg)	5.6G W-LAN Ant.1 SAR (W/kg)	ΣSAR (W/kg)		
		1	2	3	1+2	1+3	1+2+3
Head SAR	GSM 850	0.109	0.228	0.275	0.337	0.384	0.612
	GPRS 850	0.136	0.228	0.275	0.364	0.411	0.639
	GSM 1900	0.150	0.228	0.275	0.378	0.425	0.653
	GPRS 1900	0.205	0.228	0.275	0.433	0.480	0.708
	WCDMA 850	0.161	0.228	0.275	0.389	0.436	0.664
	WCDMA 1700	0.143	0.228	0.275	0.371	0.418	0.646
	WCDMA 1900	0.181	0.228	0.275	0.409	0.456	0.684
	LTE Band 17	0.082	0.228	0.275	0.31	0.357	0.585
	LTE Band 13	0.046	0.228	0.275	0.274	0.321	0.549
LTE Band 5	0.148	0.228	0.275	0.376	0.423	0.651	

Simul Tx	Configuration	GPRS 1900 SAR (W/kg)	Bluetooth Ant.1 SAR (W/kg)	5.6G W-LAN Ant.1 SAR (W/kg)	ΣSAR (W/kg)		
		1	2	3	1+2	1+3	1+2+3
Head SAR	Left Touch	0.227	0.035	0.069	0.262	0.296	0.331
	Right Touch	0.205	0.228	0.275	0.433	0.480	0.708
	Left Tilt	0.194	0.019	0.101	0.213	0.295	0.314
	Right Tilt	0.140	0.081	0.216	0.221	0.356	0.437

Note : The above simultaneous result is the worst case result for 2G/3G/4G + Bluetooth Ant1 + 5.6G WLAN Ant1 simultaneous case for held to ear.

Table 13.4.18 Simultaneous Transmission Scenario for 2G/3G/4G with Bluetooth Ant.1 and 5.8 GHz Ant.1 W-LAN (Held to Ear)

Exposure Condition	Mode	2G/3G/4G SAR (W/kg)	Bluetooth Ant.1 SAR (W/kg)	5.8G W-LAN Ant.1 SAR (W/kg)	ΣSAR (W/kg)		
		1	2	3	1+2	1+3	1+2+3
Head SAR	GSM 850	0.109	0.228	0.384	0.337	0.493	0.721
	GPRS 850	0.136	0.228	0.384	0.364	0.520	0.748
	GSM 1900	0.150	0.228	0.384	0.378	0.534	0.762
	GPRS 1900	0.205	0.228	0.384	0.433	0.589	0.817
	WCDMA 850	0.161	0.228	0.384	0.389	0.545	0.773
	WCDMA 1700	0.143	0.228	0.384	0.371	0.527	0.755
	WCDMA 1900	0.181	0.228	0.384	0.409	0.565	0.793
	LTE Band 17	0.082	0.228	0.384	0.31	0.466	0.694
	LTE Band 13	0.046	0.228	0.384	0.274	0.430	0.658
	LTE Band 5	0.148	0.228	0.384	0.376	0.532	0.760

Simul Tx	Configuration	GPRS 1900 SAR (W/kg)	Bluetooth Ant.1 SAR (W/kg)	5.8G W-LAN Ant.1 SAR (W/kg)	ΣSAR (W/kg)		
		1	2	3	1+2	1+3	1+2+3
Head SAR	Left Touch	0.227	0.035	0.081	0.262	0.308	0.343
	Right Touch	0.205	0.228	0.384	0.433	0.589	0.817
	Left Tilt	0.194	0.019	0.079	0.213	0.273	0.292
	Right Tilt	0.140	0.081	0.198	0.221	0.338	0.419

Note : The above simultaneous result is the worst case result for 2G/3G/4G + Bluetooth Ant1 + 5.8G WLAN Ant1 simultaneous case for held to ear.

Table 13.4.19 Simultaneous Transmission Scenario for 2G/3G/4G with Bluetooth Ant.1 and 5.3 GHz Ant.2 W-LAN (Held to Ear)

Exposure Condition	Mode	2G/3G/4G SAR (W/kg)	Bluetooth Ant.1 SAR (W/kg)	5.3G W-LAN Ant.2 SAR (W/kg)	ΣSAR (W/kg)		
		1	2	3	1+2	1+3	1+2+3
Head SAR	GSM 850	0.109	0.228	0.586	0.337	0.695	0.923
	GPRS 850	0.136	0.228	0.586	0.364	0.722	0.950
	GSM 1900	0.150	0.228	0.586	0.378	0.736	0.964
	GPRS 1900	0.205	0.228	0.586	0.433	0.791	1.019
	WCDMA 850	0.161	0.228	0.586	0.389	0.747	0.975
	WCDMA 1700	0.143	0.228	0.586	0.371	0.729	0.957
	WCDMA 1900	0.181	0.228	0.586	0.409	0.767	0.995
	LTE Band 17	0.082	0.228	0.586	0.31	0.668	0.896
	LTE Band 13	0.046	0.228	0.586	0.274	0.632	0.860
	LTE Band 5	0.148	0.228	0.586	0.376	0.734	0.962

Simul Tx	Configuration	GPRS 1900 SAR (W/kg)	Bluetooth Ant.1 SAR (W/kg)	5.3G W-LAN Ant.2 SAR (W/kg)	ΣSAR (W/kg)		
		1	2	3	1+2	1+3	1+2+3
Head SAR	Left Touch	0.227	0.035	0.239	0.262	0.466	0.501
	Right Touch	0.205	0.228	0.586	0.433	0.791	1.019
	Left Tilt	0.194	0.019	0.289	0.213	0.483	0.502
	Right Tilt	0.140	0.081	0.688	0.221	0.828	0.909

Note : The above simultaneous result is the worst case result for 2G/3G/4G + Bluetooth Ant1 + 5.3G WLAN Ant2 simultaneous case for held to ear.

Table 13.4.20 Simultaneous Transmission Scenario for 2G/3G/4G with Bluetooth Ant.2 and 5.6 GHz Ant.1 W-LAN (Held to Ear)

Exposure Condition	Mode	2G/3G/4G SAR (W/kg)	Bluetooth Ant.1 SAR (W/kg)	5.6G W-LAN Ant.2 SAR (W/kg)	ΣSAR (W/kg)		
		1	2	3	1+2	1+3	1+2+3
Head SAR	GSM 850	0.109	0.228	0.183	0.337	0.292	0.520
	GPRS 850	0.136	0.228	0.183	0.364	0.319	0.547
	GSM 1900	0.150	0.228	0.183	0.378	0.333	0.561
	GPRS 1900	0.205	0.228	0.183	0.433	0.388	0.616
	WCDMA 850	0.161	0.228	0.183	0.389	0.344	0.572
	WCDMA 1700	0.143	0.228	0.183	0.371	0.326	0.554
	WCDMA 1900	0.181	0.228	0.183	0.409	0.364	0.592
	LTE Band 17	0.082	0.228	0.183	0.31	0.265	0.493
	LTE Band 13	0.046	0.228	0.183	0.274	0.229	0.457
	LTE Band 5	0.148	0.228	0.183	0.376	0.331	0.559

Simul Tx	Configuration	GPRS 1900 SAR (W/kg)	Bluetooth Ant.1 SAR (W/kg)	5.6G W-LAN Ant.2 SAR (W/kg)	ΣSAR (W/kg)		
		1	2	3	1+2	1+3	1+2+3
Head SAR	Left Touch	0.227	0.035	0.110	0.262	0.337	0.372
	Right Touch	0.205	0.228	0.183	0.433	0.388	0.616
	Left Tilt	0.194	0.019	0.154	0.213	0.348	0.367
	Right Tilt	0.140	0.081	0.207	0.221	0.347	0.428

Note : The above simultaneous result is the worst case result for 2G/3G/4G + Bluetooth Ant1 + 5.6G WLAN Ant.1 simultaneous case for held to ear.

Table 13.4.21 Simultaneous Transmission Scenario for 2G/3G/4G with Bluetooth Ant.2 and 5.8 GHz Ant.1 W-LAN (Held to Ear)

Exposure Condition	Mode	2G/3G/4G SAR (W/kg)	Bluetooth Ant.1 SAR (W/kg)	5.8G W-LAN Ant.2 SAR (W/kg)	ΣSAR (W/kg)		
		1	2	3	1+2	1+3	1+2+3
Head SAR	GSM 850	0.109	0.228	0.165	0.337	0.274	0.502
	GPRS 850	0.136	0.228	0.165	0.364	0.301	0.529
	GSM 1900	0.150	0.228	0.165	0.378	0.315	0.543
	GPRS 1900	0.205	0.228	0.165	0.433	0.370	0.598
	WCDMA 850	0.161	0.228	0.165	0.389	0.326	0.554
	WCDMA 1700	0.143	0.228	0.165	0.371	0.308	0.536
	WCDMA 1900	0.181	0.228	0.165	0.409	0.346	0.574
	LTE Band 17	0.082	0.228	0.165	0.31	0.247	0.475
	LTE Band 13	0.046	0.228	0.165	0.274	0.211	0.439
	LTE Band 5	0.148	0.228	0.165	0.376	0.313	0.541

Simul Tx	Configuration	GPRS 1900 SAR (W/kg)	Bluetooth Ant.1 SAR (W/kg)	5.8G W-LAN Ant.2 SAR (W/kg)	ΣSAR (W/kg)		
		1	2	3	1+2	1+3	1+2+3
Head SAR	Left Touch	0.227	0.035	0.095	0.262	0.322	0.357
	Right Touch	0.205	0.228	0.165	0.433	0.370	0.598
	Left Tilt	0.194	0.019	0.120	0.213	0.314	0.333
	Right Tilt	0.140	0.081	0.176	0.221	0.316	0.397

Note : The above simultaneous result is the worst case result for 2G/3G/4G + Bluetooth Ant1 + 5.8G WLAN Ant2 simultaneous case for held to ear.

Table 13.4.22 Simultaneous Transmission Scenario for 2G/3G/4G with Bluetooth Ant.1 and 5.3 GHz MIMO W-LAN (Held to Ear)

Exposure Condition	Mode	2G/3G/4G SAR (W/kg)	Bluetooth Ant.1 SAR (W/kg)	5.3G W-LAN MIMO SAR (W/kg)	ΣSAR (W/kg)		
		1	2	3	1+2	1+3	1+2+3
Head SAR	GSM 850	0.109	0.228	0.785	0.337	0.894	1.122
	GPRS 850	0.136	0.228	0.785	0.364	0.921	1.149
	GSM 1900	0.150	0.228	0.785	0.378	0.935	1.163
	GPRS 1900	0.205	0.228	0.785	0.433	0.990	1.218
	WCDMA 850	0.161	0.228	0.785	0.389	0.946	1.174
	WCDMA 1700	0.143	0.228	0.785	0.371	0.928	1.156
	WCDMA 1900	0.181	0.228	0.785	0.409	0.966	1.194
	LTE Band 17	0.082	0.228	0.785	0.310	0.867	1.095
	LTE Band 13	0.046	0.228	0.785	0.274	0.831	1.059
	LTE Band 5	0.148	0.228	0.785	0.376	0.933	1.161

Simul Tx	Configuration	GPRS 1900 SAR (W/kg)	Bluetooth Ant.1 SAR (W/kg)	5.3G W-LAN MIMO SAR (W/kg)	ΣSAR (W/kg)		
		1	2	3	1+2	1+3	1+2+3
Head SAR	Left Touch	0.227	0.035	0.314	0.262	0.541	0.576
	Right Touch	0.205	0.228	0.785	0.433	0.990	1.218
	Left Tilt	0.194	0.019	0.415	0.213	0.609	0.628
	Right Tilt	0.140	0.081	0.948	0.221	1.088	1.169

Note : The above simultaneous result is the worst case result for 2G/3G/4G + Bluetooth Ant1 + 5.3G WLAN MIMO simultaneous case for held to ear.

Table 13.4.23 Simultaneous Transmission Scenario for 2G/3G/4G with Bluetooth Ant.1 and 5.6 GHz MIMO W-LAN (Held to Ear)

Exposure Condition	Mode	2G/3G/4G SAR (W/kg)	Bluetooth Ant.1 SAR (W/kg)	5.6G W-LAN MIMO SAR (W/kg)	ΣSAR (W/kg)		
		1	2	3	1+2	1+3	1+2+3
Head SAR	GSM 850	0.109	0.228	0.525	0.337	0.634	0.862
	GPRS 850	0.136	0.228	0.525	0.364	0.661	0.889
	GSM 1900	0.150	0.228	0.525	0.378	0.675	0.903
	GPRS 1900	0.205	0.228	0.525	0.433	0.730	0.958
	WCDMA 850	0.161	0.228	0.525	0.389	0.686	0.914
	WCDMA 1700	0.143	0.228	0.525	0.371	0.668	0.896
	WCDMA 1900	0.181	0.228	0.525	0.409	0.706	0.934
	LTE Band 17	0.082	0.228	0.525	0.310	0.607	0.835
	LTE Band 13	0.046	0.228	0.525	0.274	0.571	0.799
	LTE Band 5	0.148	0.228	0.525	0.376	0.673	0.901

Simul Tx	Configuration	GPRS 1900 SAR (W/kg)	Bluetooth Ant.1 SAR (W/kg)	5.6G W-LAN MIMO SAR (W/kg)	ΣSAR (W/kg)		
		1	2	3	1+2	1+3	1+2+3
Head SAR	Left Touch	0.227	0.035	0.214	0.262	0.441	0.476
	Right Touch	0.205	0.228	0.525	0.433	0.730	0.958
	Left Tilt	0.194	0.019	0.224	0.213	0.418	0.437
	Right Tilt	0.140	0.081	0.607	0.221	0.747	0.828

Note : The above simultaneous result is the worst case result for 2G/3G/4G + Bluetooth Ant1 + 5.6G WLAN MIMO simultaneous case for held to ear.

Table 13.4.24 Simultaneous Transmission Scenario for 2G/3G/4G with Bluetooth Ant.1 and 5.8 GHz MIMO W-LAN (Held to Ear)

Exposure Condition	Mode	2G/3G/4G SAR (W/kg)	Bluetooth Ant.1 SAR (W/kg)	5.8G W-LAN MIMO SAR (W/kg)	ΣSAR (W/kg)		
		1	2	3	1+2	1+3	1+2+3
Head SAR	GSM 850	0.109	0.228	0.555	0.337	0.664	0.892
	GPRS 850	0.136	0.228	0.555	0.364	0.691	0.919
	GSM 1900	0.150	0.228	0.555	0.378	0.705	0.933
	GPRS 1900	0.205	0.228	0.555	0.433	0.760	0.988
	WCDMA 850	0.161	0.228	0.555	0.389	0.716	0.944
	WCDMA 1700	0.143	0.228	0.555	0.371	0.698	0.926
	WCDMA 1900	0.181	0.228	0.555	0.409	0.736	0.964
	LTE Band 17	0.082	0.228	0.555	0.310	0.637	0.865
	LTE Band 13	0.046	0.228	0.555	0.274	0.601	0.829
	LTE Band 5	0.148	0.228	0.555	0.376	0.703	0.931

Simul Tx	Configuration	GPRS 1900 SAR (W/kg)	Bluetooth Ant.1 SAR (W/kg)	5.8G W-LAN MIMO SAR (W/kg)	ΣSAR (W/kg)		
		1	2	3	1+2	1+3	1+2+3
Head SAR	Left Touch	0.227	0.035	0.148	0.262	0.375	0.410
	Right Touch	0.205	0.228	0.555	0.433	0.760	0.988
	Left Tilt	0.194	0.019	0.194	0.213	0.388	0.407
	Right Tilt	0.140	0.081	0.401	0.221	0.541	0.622

Note : The above simultaneous result is the worst case result for 2G/3G/4G + Bluetooth Ant1 + 5.8G WLAN MIMO simultaneous case for held to ear.

Table 13.4.25 Simultaneous Transmission Scenario for 2.4 GHz Ant.1 and 5 GHz Ant.2 W-LAN (Held to Ear)

Simul Tx	Configuration	2.4G W-LAN Ant.1 SAR (W/kg)	5.3G W-LAN Ant.2 SAR (W/kg)	Σ SAR (W/kg)
		1	2	1+2
Head SAR	Left Touch	0.110	0.239	0.349
	Right Touch	0.484	0.586	1.070
	Left Tilt	0.062	0.289	0.351
	Right Tilt	0.234	0.688	0.922

Simul Tx	Configuration	2.4G W-LAN Ant.1 SAR (W/kg)	5.6G W-LAN Ant.2 SAR (W/kg)	Σ SAR (W/kg)
		1	2	1+2
Head SAR	Left Touch	0.110	0.110	0.220
	Right Touch	0.484	0.183	0.667
	Left Tilt	0.062	0.154	0.216
	Right Tilt	0.234	0.207	0.441

Simul Tx	Configuration	2.4G W-LAN Ant.1 SAR (W/kg)	5.8G W-LAN Ant.2 SAR (W/kg)	Σ SAR (W/kg)
		1	2	1+2
Head SAR	Left Touch	0.110	0.095	0.205
	Right Touch	0.484	0.165	0.649
	Left Tilt	0.062	0.120	0.182
	Right Tilt	0.234	0.176	0.410

Note : The above simultaneous result is the worst case result for 2.4G WLAN Ant1 + 5G WLAN Ant2 simultaneous case for held to ear.

Table 13.4.26 Simultaneous Transmission Scenario for Bluetooth Ant.1 and 5 GHz Ant.1 W-LAN (Held to Ear)

Simul Tx	Configuration	Bluetooth Ant.1 SAR (W/kg)	5.3G W-LAN Ant.1 SAR (W/kg)	Σ SAR (W/kg)
		1	2	1+2
Head SAR	Left Touch	0.035	0.064	0.099
	Right Touch	0.228	0.176	0.404
	Left Tilt	0.019	0.060	0.079
	Right Tilt	0.081	0.157	0.238

Simul Tx	Configuration	Bluetooth Ant.1 SAR (W/kg)	5.6G W-LAN Ant.1 SAR (W/kg)	Σ SAR (W/kg)
		1	2	1+2
Head SAR	Left Touch	0.035	0.069	0.104
	Right Touch	0.228	0.275	0.503
	Left Tilt	0.019	0.101	0.120
	Right Tilt	0.081	0.216	0.297

Simul Tx	Configuration	Bluetooth Ant.1 SAR (W/kg)	5.8G W-LAN Ant.1 SAR (W/kg)	Σ SAR (W/kg)
		1	2	1+2
Head SAR	Left Touch	0.035	0.081	0.116
	Right Touch	0.228	0.384	0.612
	Left Tilt	0.019	0.079	0.098
	Right Tilt	0.081	0.198	0.279

Note : The above simultaneous result is the worst case result for Bluetooth Ant1 + 5G WLAN Ant1 simultaneous case for held to ear.

Table 13.4.27 Simultaneous Transmission Scenario for Bluetooth Ant.2 and 5 GHz Ant.2 W-LAN (Held to Ear)

Simul Tx	Configuration	Bluetooth Ant.1 SAR (W/kg)	5.3G W-LAN Ant.2 SAR (W/kg)	Σ SAR (W/kg)
		1	2	1+2
Head SAR	Left Touch	0.035	0.239	0.274
	Right Touch	0.228	0.586	0.814
	Left Tilt	0.019	0.289	0.308
	Right Tilt	0.081	0.688	0.769

Simul Tx	Configuration	Bluetooth Ant.1 SAR (W/kg)	5.6G W-LAN Ant.2 SAR (W/kg)	Σ SAR (W/kg)
		1	2	1+2
Head SAR	Left Touch	0.035	0.110	0.145
	Right Touch	0.228	0.183	0.411
	Left Tilt	0.019	0.154	0.173
	Right Tilt	0.081	0.207	0.288

Simul Tx	Configuration	Bluetooth Ant.1 SAR (W/kg)	5.8G W-LAN Ant.2 SAR (W/kg)	Σ SAR (W/kg)
		1	2	1+2
Head SAR	Left Touch	0.035	0.095	0.130
	Right Touch	0.228	0.165	0.393
	Left Tilt	0.019	0.120	0.139
	Right Tilt	0.081	0.176	0.257

Note : The above simultaneous result is the worst case result for Bluetooth Ant1 + 5G WLAN Ant2 simultaneous case for held to ear.

Table 13.4.28 Simultaneous Transmission Scenario for Bluetooth Ant.1 and 5 GHz MIMO W-LAN (Held to Ear)

Simul Tx	Configuration	Bluetooth Ant.1 SAR (W/kg)	5.3G W-LAN MIMO SAR (W/kg)	Σ SAR (W/kg)
		1	2	1+2
Head SAR	Left Touch	0.035	0.314	0.349
	Right Touch	0.228	0.785	1.013
	Left Tilt	0.019	0.415	0.434
	Right Tilt	0.081	0.948	1.029

Simul Tx	Configuration	Bluetooth Ant.1 SAR (W/kg)	5.6G W-LAN MIMO SAR (W/kg)	Σ SAR (W/kg)
		1	2	1+2
Head SAR	Left Touch	0.035	0.214	0.249
	Right Touch	0.228	0.525	0.753
	Left Tilt	0.019	0.224	0.243
	Right Tilt	0.081	0.607	0.688

Simul Tx	Configuration	Bluetooth Ant.1 SAR (W/kg)	5.8G W-LAN MIMO SAR (W/kg)	Σ SAR (W/kg)
		1	2	1+2
Head SAR	Left Touch	0.035	0.148	0.183
	Right Touch	0.228	0.555	0.783
	Left Tilt	0.019	0.194	0.213
	Right Tilt	0.081	0.401	0.482

Note : The above simultaneous result is the worst case result for Bluetooth Ant1 + 5G WLAN MIMO simultaneous case for held to ear.

Table 13.4.29 Simultaneous Transmission Scenario for 2G/3G/4G with Bluetooth (Held to Ear)

Exposure Condition	Mode	2G/3G/4G SAR (W/kg)	Bluetooth SAR (W/kg)	Σ SAR (W/kg)
		1	2	1+2
Head SAR	GSM 850	0.109	0.228	0.337
	GPRS 850	0.136	0.228	0.364
	GSM 1900	0.150	0.228	0.378
	GPRS 1900	0.205	0.228	0.433
	WCDMA 850	0.161	0.228	0.389
	WCDMA 1700	0.143	0.228	0.371
	WCDMA 1900	0.181	0.228	0.409
	LTE Band 17	0.082	0.228	0.310
	LTE Band 13	0.046	0.228	0.274
	LTE Band 5	0.148	0.228	0.376

Simul Tx	Configuration	WCDMA 850 SAR (W/kg)	Bluetooth SAR (W/kg)	Σ SAR (W/kg)
		1	2	1+2
Head SAR	Left Touch	0.227	0.035	0.262
	Right Touch	0.205	0.228	0.433
	Left Tilt	0.194	0.019	0.213
	Right Tilt	0.140	0.081	0.221

Note : The above simultaneous result is the worst case result for 2G/3G/4G + Bluetooth simultaneous case for held to ear.

13.5 Body-Worn Simultaneous Transmission Analysis

All simultaneous cases were investigated and the worst case simultaneous results are reported for each band/mode/configuration.

Table 13.5.1 Simultaneous Transmission Scenario for 2G/3G/4G with 2.4 GHz W-LAN (Body-Worn at 10 mm)

Exposure Condition	Mode	2G/3G/4G SAR (W/kg)	2.4G W-LAN Ant.1. SAR (W/kg)	ΣSAR (W/kg)
		1	2	1+2
Body-Worn SAR	GSM 850	0.577	0.104	0.681
	GPRS 850	0.746	0.104	0.850
	GSM 1900	0.715	0.107	0.822
	GPRS 1900	0.989	0.107	1.096
	WCDMA 850	0.759	0.104	0.863
	WCDMA 1700	0.500	0.107	0.607
	WCDMA 1900	0.956	0.107	1.063
	LTE Band 17	0.458	0.104	0.562
	LTE Band 13	0.271	0.104	0.375
LTE Band 5	0.729	0.104	0.833	

Simul Tx	Configuration	GPRS 1900 SAR (W/kg)	2.4G W-LAN Ant.1. SAR (W/kg)	ΣSAR (W/kg)
		1	2	1+2
Body-Worn SAR	Front	0.989	0.107	1.096
	Rear	0.873	0.104	0.977

Note : The above simultaneous result is the worst case result for 2G/3G/4G + 2.4G WLAN Ant1 simultaneous case for body worn.

Table 13.5.2 Simultaneous Transmission Scenario for 2G/3G/4G with 2.4 GHz W-LAN (Body-Worn at 10 mm)

Exposure Condition	Mode	2G/3G/4G SAR (W/kg)	2.4G W-LAN Ant.2. SAR (W/kg)	Σ SAR (W/kg)
		1	2	1+2
Body-Worn SAR	GSM 850	0.577	0.127	0.704
	GPRS 850	0.746	0.127	0.873
	GSM 1900	0.715	0.121	0.836
	GPRS 1900	0.989	0.121	1.110
	WCDMA 850	0.759	0.127	0.886
	WCDMA 1700	0.500	0.121	0.621
	WCDMA 1900	0.956	0.121	1.077
	LTE Band 17	0.458	0.127	0.585
	LTE Band 13	0.271	0.127	0.398
	LTE Band 5	0.729	0.127	0.856

Simul Tx	Configuration	GPRS 1900 SAR (W/kg)	2.4G W-LAN Ant.2. SAR (W/kg)	Σ SAR (W/kg)
		1	2	1+2
Body-Worn SAR	Front	0.989	0.121	1.110
	Rear	0.873	0.127	1.000

Note : The above simultaneous result is the worst case result for 2G/3G/4G + 2.4G WLAN Ant2 simultaneous case for body worn.

Table 13.5.3 Simultaneous Transmission Scenario for 2G/3G/4G with 2.4 GHz W-LAN (Body-Worn at 10 mm)

Exposure Condition	Mode	2G/3G/4G SAR (W/kg)	2.4G W-LAN MIMO SAR (W/kg)	Σ SAR (W/kg)
		1	2	1+2
Body-Worn SAR	GSM 850	0.577	0.183	0.760
	GPRS 850	0.746	0.183	0.929
	GSM 1900	0.715	0.159	0.874
	GPRS 1900	0.989	0.159	1.148
	WCDMA 850	0.759	0.183	0.942
	WCDMA 1700	0.490	0.183	0.673
	WCDMA 1900	0.956	0.159	1.115
	LTE Band 17	0.458	0.183	0.641
	LTE Band 13	0.271	0.183	0.454
	LTE Band 5	0.729	0.183	0.912

Simul Tx	Configuration	GPRS 1900 SAR (W/kg)	2.4G W-LAN MIMO SAR (W/kg)	Σ SAR (W/kg)
		1	2	1+2
Body-Worn SAR	Front	0.989	0.159	1.148
	Rear	0.873	0.183	1.056

Note : The above simultaneous result is the worst case result for 2G/3G/4G + 2.4G WLAN MIMO simultaneous case for body worn.

Table 13.5.4 Simultaneous Transmission Scenario for 2G/3G/4G with 5.3 GHz W-LAN (Body-Worn at 10 mm)

Exposure Condition	Mode	2G/3G/4G SAR (W/kg)	5.3G W-LAN Ant.1 SAR (W/kg)	Σ SAR (W/kg)
		1	2	1+2
Body-Worn SAR	GSM 850	0.577	0.550	1.127
	GPRS 850	0.746	0.550	1.296
	GSM 1900	0.678	0.550	1.228
	GPRS 1900	0.873	0.550	1.423
	WCDMA 850	0.759	0.550	1.309
	WCDMA 1700	0.490	0.550	1.040
	WCDMA 1900	0.862	0.550	1.412
	LTE Band 17	0.458	0.550	1.008
	LTE Band 13	0.271	0.550	0.821
LTE Band 5	0.729	0.550	1.279	

Simul Tx	Configuration	GPRS 1900 SAR (W/kg)	5.3G W-LAN Ant.1 SAR (W/kg)	Σ SAR (W/kg)
		1	2	1+2
Body-Worn SAR	Front	0.989	0.041	1.030
	Rear	0.873	0.550	1.423

Note : The above simultaneous result is the worst case result for 2G/3G/4G + 5.3G WLAN Ant1 simultaneous case for body worn.

Table 13.5.5 Simultaneous Transmission Scenario for 2G/3G/4G with 5.3 GHz W-LAN (Body-Worn at 10 mm)

Exposure Condition	Mode	2G/3G/4G SAR (W/kg)	5.3G W-LAN Ant.2 SAR (W/kg)	Σ SAR (W/kg)
		1	2	1+2
Body-Worn SAR	GSM 850	0.577	0.333	0.910
	GPRS 850	0.746	0.333	1.079
	GSM 1900	0.678	0.333	1.011
	GPRS 1900	0.873	0.333	1.206
	WCDMA 850	0.759	0.333	1.092
	WCDMA 1700	0.490	0.333	0.823
	WCDMA 1900	0.862	0.333	1.195
	LTE Band 17	0.458	0.333	0.791
	LTE Band 13	0.271	0.333	0.604
	LTE Band 51	0.729	0.333	1.062

Simul Tx	Configuration	GPRS 1900 SAR (W/kg)	5.3G W-LAN Ant.2 SAR (W/kg)	Σ SAR (W/kg)
		1	2	1+2
Body-Worn SAR	Front	0.989	0.059	1.048
	Rear	0.873	0.333	1.206

Note : The above simultaneous result is the worst case result for 2G/3G/4G + 5.3G WLAN Ant2 simultaneous case for body worn.

Table 13.5.6 Simultaneous Transmission Scenario for 2G/3G/4G with 5.3 GHz W-LAN (Body-Worn at 10 mm)

Exposure Condition	Mode	2G/3G/4G SAR (W/kg)	5.3G W-LAN MIMO SAR (W/kg)	Σ SAR (W/kg)
		1	2	1+2
Body-Worn SAR	GSM 850	0.577	0.567	1.144
	GPRS 850	0.746	0.567	1.313
	GSM 1900	0.678	0.567	1.245
	GPRS 1900	0.873	0.567	1.440
	WCDMA 850	0.759	0.567	1.326
	WCDMA 1700	0.490	0.567	1.057
	WCDMA 1900	0.862	0.567	1.429
	LTE Band 17	0.458	0.567	1.025
	LTE Band 13	0.271	0.567	0.838
	LTE Band 5	0.729	0.567	1.296

Simul Tx	Configuration	GPRS 1900 SAR (W/kg)	5.3G W-LAN MIMO SAR (W/kg)	Σ SAR (W/kg)
		1	2	1+2
Body-Worn SAR	Front	0.989	0.092	1.081
	Rear	0.873	0.567	1.440

Note : The above simultaneous result is the worst case result for 2G/3G/4G + 5.3G WLAN MIMO simultaneous case for body worn.

Table 13.5.7 Simultaneous Transmission Scenario for 2G/3G/4G with 5.6 GHz W-LAN (Body-Worn at 10 mm)

Exposure Condition	Mode	2G/3G/4G SAR (W/kg)	5.6G W-LAN Ant.1 SAR (W/kg)	Σ SAR (W/kg)
		1	2	1+2
Body-Worn SAR	GSM 850	0.577	0.478	1.055
	GPRS 850	0.746	0.478	1.224
	GSM 1900	0.678	0.478	1.156
	GPRS 1900	0.873	0.478	1.351
	WCDMA 850	0.759	0.478	1.237
	WCDMA 1700	0.490	0.478	0.968
	WCDMA 1900	0.862	0.478	1.340
	LTE Band 17	0.458	0.478	0.936
	LTE Band 13	0.271	0.478	0.749
	LTE Band 5	0.729	0.478	1.207

Simul Tx	Configuration	GPRS 1900 SAR (W/kg)	5.6G W-LAN Ant.1 SAR (W/kg)	Σ SAR (W/kg)
		1	2	1+2
Body-Worn SAR	Front	0.989	0.047	1.036
	Rear	0.873	0.478	1.351

Note : The above simultaneous result is the worst case result for 2G/3G/4G + 5.6G WLAN Ant1 simultaneous case for body worn.

Table 13.5.8 Simultaneous Transmission Scenario for 2G/3G/4G with 5.6 GHz W-LAN (Body-Worn at 10 mm)

Exposure Condition	Mode	2G/3G/4G SAR (W/kg)	5.6G W-LAN Ant.2 SAR (W/kg)	Σ SAR (W/kg)
		1	2	1+2
Body-Worn SAR	GSM 850	0.577	0.315	0.892
	GPRS 850	0.746	0.315	1.061
	GSM 1900	0.678	0.315	0.993
	GPRS 1900	0.873	0.315	1.188
	WCDMA 850	0.759	0.315	1.074
	WCDMA 1700	0.490	0.315	0.805
	WCDMA 1900	0.862	0.315	1.177
	LTE Band 17	0.458	0.315	0.773
	LTE Band 13	0.271	0.315	0.586
	LTE Band 5	0.729	0.315	1.044

Simul Tx	Configuration	GPRS 1900 SAR (W/kg)	5.6G W-LAN Ant.2 SAR (W/kg)	Σ SAR (W/kg)
		1	2	1+2
Body-Worn SAR	Front	0.989	0.035	1.024
	Rear	0.873	0.315	1.188

Note : The above simultaneous result is the worst case result for 2G/3G/4G + 5.6G WLAN Ant2 simultaneous case for body worn.

Table 13.5.9 Simultaneous Transmission Scenario for 2G/3G/4G with 5.6 GHz W-LAN (Body-Worn at 10 mm)

Exposure Condition	Mode	2G/3G/4G SAR (W/kg)	5.6G W-LAN MIMO SAR (W/kg)	Σ SAR (W/kg)
		1	2	1+2
Body-Worn SAR	GSM 850	0.577	0.504	1.081
	GPRS 850	0.746	0.504	1.250
	GSM 1900	0.678	0.504	1.182
	GPRS 1900	0.873	0.504	1.377
	WCDMA 850	0.759	0.504	1.263
	WCDMA 1700	0.490	0.504	0.994
	WCDMA 1900	0.862	0.504	1.366
	LTE Band 17	0.458	0.504	0.962
	LTE Band 13	0.271	0.504	0.775
	LTE Band 5	0.729	0.504	1.233

Simul Tx	Configuration	GPRS 1900 SAR (W/kg)	5.6G W-LAN MIMO SAR (W/kg)	Σ SAR (W/kg)
		1	2	1+2
Body-Worn SAR	Front	0.989	0.075	1.064
	Rear	0.873	0.504	1.377

Note : The above simultaneous result is the worst case result for 2G/3G/4G + 5.6G WLAN MIMO simultaneous case for body worn.

Table 13.5.10 Simultaneous Transmission Scenario for 2G/3G/4G with 5.8 GHz W-LAN (Body-Worn at 10 mm)

Exposure Condition	Mode	2G/3G/4G SAR (W/kg)	5.8G W-LAN Ant.1 SAR (W/kg)	Σ SAR (W/kg)
		1	2	1+2
Body-Worn SAR	GSM 850	0.577	0.636	1.213
	GPRS 850	0.746	0.636	1.382
	GSM 1900	0.678	0.636	1.314
	GPRS 1900	0.873	0.636	1.509
	WCDMA 850	0.759	0.636	1.395
	WCDMA 1700	0.490	0.636	1.126
	WCDMA 1900	0.862	0.636	1.498
	LTE Band 17	0.458	0.636	1.094
	LTE Band 13	0.271	0.636	0.907
	LTE Band 5	0.729	0.636	1.365

Simul Tx	Configuration	GPRS 1900 SAR (W/kg)	5.8G W-LAN Ant.1 SAR (W/kg)	Σ SAR (W/kg)
		1	2	1+2
Body-Worn SAR	Front	0.989	0.070	1.059
	Rear	0.873	0.636	1.509

Note : The above simultaneous result is the worst case result for 2G/3G/4G + 5.8G WLAN Ant1 simultaneous case for body worn.

Table 13.5.11 Simultaneous Transmission Scenario for 2G/3G/4G with 5.8 GHz W-LAN (Body-Worn at 10 mm)

Exposure Condition	Mode	2G/3G/4G SAR (W/kg)	5.8G W-LAN Ant.2 SAR (W/kg)	Σ SAR (W/kg)
		1	2	1+2
Body-Worn SAR	GSM 850	0.577	0.181	0.758
	GPRS 850	0.746	0.181	0.927
	GSM 1900	0.678	0.181	0.859
	GPRS 1900	0.873	0.181	1.054
	WCDMA 850	0.759	0.181	0.940
	WCDMA 1700	0.490	0.181	0.671
	WCDMA 1900	0.862	0.181	1.043
	LTE Band 17	0.458	0.181	0.639
	LTE Band 13	0.271	0.181	0.452
	LTE Band 5	0.729	0.181	0.910

Simul Tx	Configuration	GPRS 1900 SAR (W/kg)	5.8G W-LAN Ant.2 SAR (W/kg)	Σ SAR (W/kg)
		1	2	1+2
Body-Worn SAR	Front	0.989	0.016	1.005
	Rear	0.873	0.181	1.054

Note : The above simultaneous result is the worst case result for 2G/3G/4G + 5.8G WLAN Ant2 simultaneous case for body worn.

Table 13.5.12 Simultaneous Transmission Scenario for 2G/3G/4G with 5.8 GHz W-LAN (Body-Worn at 10 mm)

Exposure Condition	Mode	2G/3G/4G SAR (W/kg)	5.8G W-LAN MIMO SAR (W/kg)	Σ SAR (W/kg)
		1	2	1+2
Body-Worn SAR	GSM 850	0.577	0.527	1.104
	GPRS 850	0.746	0.527	1.273
	GSM 1900	0.678	0.527	1.205
	GPRS 1900	0.873	0.527	1.400
	WCDMA 850	0.759	0.527	1.286
	WCDMA 1700	0.490	0.527	1.017
	WCDMA 1900	0.862	0.527	1.389
	LTE Band 17	0.458	0.527	0.985
	LTE Band 13	0.271	0.527	0.798
	LTE Band 5	0.729	0.527	1.256

Simul Tx	Configuration	GPRS 1900 SAR (W/kg)	5.8G W-LAN MIMO SAR (W/kg)	Σ SAR (W/kg)
		1	2	1+2
Body-Worn SAR	Front	0.989	0.075	1.064
	Rear	0.873	0.527	1.400

Note : The above simultaneous result is the worst case result for 2G/3G/4G + 5.8G WLAN MIMO simultaneous case for body worn.

Table 13.5.13 Simultaneous Transmission Scenario for 2G/3G/4G with 2.4 GHz Ant.1 and 5.3 GHz Ant.2 W-LAN (Body-Worn at 10 mm)

Exposure Condition	Mode	2G/3G/4G SAR (W/kg)	2.4G W-LAN Ant.1 SAR (W/kg)	5.3G W-LAN Ant.2 SAR (W/kg)	ΣSAR (W/kg)		
		1	2	3	1+2	1+3	1+2+3
Body-Worn SAR	GSM 850	0.577	0.104	0.333	0.681	0.910	1.014
	GPRS 850	0.746	0.104	0.333	0.850	1.079	1.183
	GSM 1900	0.678	0.104	0.333	0.782	1.011	1.115
	GPRS 1900	0.873	0.104	0.333	0.977	1.206	1.310
	WCDMA 850	0.759	0.104	0.333	0.863	1.092	1.196
	WCDMA 1700	0.490	0.104	0.333	0.594	0.823	0.927
	WCDMA 1900	0.862	0.104	0.333	0.966	1.195	1.299
	LTE Band 17	0.458	0.104	0.333	0.562	0.791	0.895
	LTE Band 13	0.271	0.104	0.333	0.375	0.604	0.708
	LTE Band 5	0.729	0.104	0.333	0.833	1.062	1.166

Simul Tx	Configuration	GPRS 1900 SAR (W/kg)	2.4G W-LAN Ant.1 SAR (W/kg)	5.3G W-LAN Ant.2 SAR (W/kg)	ΣSAR (W/kg)		
		1	2	3	1+2	1+3	1+2+3
Body-Worn SAR	Front	0.989	0.107	0.059	1.096	1.048	1.155
	Rear	0.873	0.104	0.333	0.977	1.206	1.310

Note : The above simultaneous result is the worst case result for 2G/3G/4G + 2.4G WLAN Ant1 + 5.3G WLAN Ant2 simultaneous case for body worn.

Table 13.5.14 Simultaneous Transmission Scenario for 2G/3G/4G with 2.4 GHz Ant.1 and 5.6 GHz Ant.2 W-LAN (Body-Worn at 10 mm)

Exposure Condition	Mode	2G/3G/4G SAR (W/kg)	2.4G W-LAN Ant.1 SAR (W/kg)	5.6G W-LAN Ant.2 SAR (W/kg)	ΣSAR (W/kg)		
		1	2	3	1+2	1+3	1+2+3
Body-Worn SAR	GSM 850	0.577	0.104	0.315	0.681	0.892	0.996
	GPRS 850	0.746	0.104	0.315	0.850	1.061	1.165
	GSM 1900	0.678	0.104	0.315	0.782	0.993	1.097
	GPRS 1900	0.873	0.104	0.315	0.977	1.188	1.292
	WCDMA 850	0.759	0.104	0.315	0.863	1.074	1.178
	WCDMA 1700	0.490	0.104	0.315	0.594	0.805	0.909
	WCDMA 1900	0.862	0.104	0.315	0.966	1.177	1.281
	LTE Band 17	0.458	0.104	0.315	0.562	0.773	0.877
	LTE Band 13	0.271	0.104	0.315	0.375	0.586	0.690
	LTE Band 5	0.729	0.104	0.315	0.833	1.044	1.148

Simul Tx	Configuration	GPRS 1900 SAR (W/kg)	2.4G W-LAN Ant.1 SAR (W/kg)	5.6G W-LAN Ant.2 SAR (W/kg)	ΣSAR (W/kg)		
		1	2	3	1+2	1+3	1+2+3
Body-Worn SAR	Front	0.989	0.107	0.035	1.096	1.024	1.131
	Rear	0.873	0.104	0.315	0.977	1.188	1.292

Note : The above simultaneous result is the worst case result for 2G/3G/4G + 2.4G WLAN Ant1 + 5.6G WLAN Ant2 simultaneous case for body worn.

Table 13.5.15 Simultaneous Transmission Scenario for 2G/3G/4G with 2.4 GHz Ant.1 and 5.8 GHz Ant.2 W-LAN (Body-Worn at 10 mm)

Exposure Condition	Mode	2G/3G/4G SAR (W/kg)	2.4G W-LAN Ant.1 SAR (W/kg)	5.8G W-LAN Ant.2 SAR (W/kg)	ΣSAR (W/kg)		
		1	2	3	1+2	1+3	1+2+3
Body-Worn SAR	GSM 850	0.577	0.104	0.181	0.681	0.758	0.862
	GPRS 850	0.746	0.104	0.181	0.850	0.927	1.031
	GSM 1900	0.678	0.104	0.181	0.782	0.859	0.963
	GPRS 1900	0.873	0.104	0.181	0.977	1.054	1.158
	WCDMA 850	0.759	0.104	0.181	0.863	0.940	1.044
	WCDMA 1700	0.490	0.104	0.181	0.594	0.671	0.775
	WCDMA 1900	0.862	0.104	0.181	0.966	1.043	1.147
	LTE Band 17	0.458	0.104	0.181	0.562	0.639	0.743
	LTE Band 13	0.271	0.104	0.181	0.375	0.452	0.556
	LTE Band 5	0.729	0.104	0.181	0.833	0.910	1.014

Simul Tx	Configuration	GPRS 1900 SAR (W/kg)	2.4G W-LAN Ant.1 SAR (W/kg)	5.8G W-LAN Ant.2 SAR (W/kg)	ΣSAR (W/kg)		
		1	2	3	1+2	1+3	1+2+3
Body-Worn SAR	Front	0.989	0.107	0.016	1.096	1.005	1.112
	Rear	0.873	0.104	0.181	0.977	1.054	1.158

Note : The above simultaneous result is the worst case result for 2G/3G/4G + 2.4G WLAN Ant1 + 5.8G WLAN Ant2 simultaneous case for body worn.

Table 13.5.16 Simultaneous Transmission Scenario for 2G/3G/4G with Bluetooth Ant.1 and 5.3 GHz Ant.1 W-LAN (Body-Worn at 10 mm)

Exposure Condition	Mode	2G/3G/4G SAR (W/kg)	Bluetooth Ant.1 SAR (W/kg)	5.3G W-LAN Ant.1 SAR (W/kg)	ΣSAR (W/kg)		
		1	2	3	1+2	1+3	1+2+3
Body-Worn SAR	GSM 850	0.577	0.031	0.550	0.608	1.127	1.158
	GPRS 850	0.746	0.031	0.550	0.777	1.296	1.327
	GSM 1900	0.678	0.031	0.550	0.709	1.228	1.259
	GPRS 1900	0.873	0.031	0.550	0.904	1.423	1.454
	WCDMA 850	0.759	0.031	0.550	0.790	1.309	1.340
	WCDMA 1700	0.490	0.031	0.550	0.521	1.040	1.071
	WCDMA 1900	0.862	0.031	0.550	0.893	1.412	1.443
	LTE Band 17	0.458	0.031	0.550	0.489	1.008	1.039
	LTE Band 13	0.271	0.031	0.550	0.302	0.821	0.852
	LTE Band 5	0.729	0.031	0.550	0.760	1.279	1.310

Simul Tx	Configuration	GPRS 1900 SAR (W/kg)	Bluetooth Ant.1 SAR (W/kg)	5.3G W-LAN Ant.1 SAR (W/kg)	ΣSAR (W/kg)		
		1	2	3	1+2	1+3	1+2+3
Body-Worn SAR	Front	0.989	0.035	0.041	1.024	1.030	1.065
	Rear	0.873	0.031	0.550	0.904	1.423	1.454

Note : The above simultaneous result is the worst case result for 2G/3G/4G + Bluetooth Ant1 + 5.3G WLAN Ant1 simultaneous case for body worn.

Table 13.5.17 Simultaneous Transmission Scenario for 2G/3G/4G with Bluetooth Ant.1 and 5.6 GHz Ant.1 W-LAN (Body-Worn at 10 mm)

Exposure Condition	Mode	2G/3G/4G SAR (W/kg)	Bluetooth Ant.1 SAR (W/kg)	5.6G W-LAN Ant.1 SAR (W/kg)	ΣSAR (W/kg)		
		1	2	3	1+2	1+3	1+2+3
Body-Worn SAR	GSM 850	0.577	0.031	0.478	0.608	1.055	1.086
	GPRS 850	0.746	0.031	0.478	0.777	1.224	1.255
	GSM 1900	0.678	0.031	0.478	0.709	1.156	1.187
	GPRS 1900	0.873	0.031	0.478	0.904	1.351	1.382
	WCDMA 850	0.759	0.031	0.478	0.790	1.237	1.268
	WCDMA 1700	0.490	0.031	0.478	0.521	0.968	0.999
	WCDMA 1900	0.862	0.031	0.478	0.893	1.340	1.371
	LTE Band 17	0.458	0.031	0.478	0.489	0.936	0.967
	LTE Band 13	0.271	0.031	0.478	0.302	0.749	0.780
	LTE Band 5	0.729	0.031	0.478	0.760	1.207	1.238

Simul Tx	Configuration	GPRS 1900 SAR (W/kg)	Bluetooth Ant.1 SAR (W/kg)	5.6G W-LAN Ant.1 SAR (W/kg)	ΣSAR (W/kg)		
		1	2	3	1+2	1+3	1+2+3
Body-Worn SAR	Front	0.989	0.035	0.047	1.024	1.036	1.071
	Rear	0.873	0.031	0.478	0.904	1.351	1.382

Note : The above simultaneous result is the worst case result for 2G/3G/4G + Bluetooth Ant1 + 5.6G WLAN Ant1 simultaneous case for body worn.

Table 13.5.18 Simultaneous Transmission Scenario for 2G/3G/4G with Bluetooth Ant.1 and 5.8 GHz Ant.1 W-LAN (Body-Worn at 10 mm)

Exposure Condition	Mode	2G/3G/4G SAR (W/kg)	Bluetooth Ant.1 SAR (W/kg)	5.8G W-LAN Ant.1 SAR (W/kg)	ΣSAR (W/kg)		
		1	2	3	1+2	1+3	1+2+3
Body-Worn SAR	GSM 850	0.577	0.031	0.636	0.608	1.213	1.244
	GPRS 850	0.746	0.031	0.636	0.777	1.382	1.413
	GSM 1900	0.678	0.031	0.636	0.709	1.314	1.345
	GPRS 1900	0.873	0.031	0.636	0.904	1.509	1.540
	WCDMA 850	0.759	0.031	0.636	0.790	1.395	1.426
	WCDMA 1700	0.490	0.031	0.636	0.521	1.126	1.157
	WCDMA 1900	0.862	0.031	0.636	0.893	1.498	1.529
	LTE Band 17	0.458	0.031	0.636	0.489	1.094	1.125
	LTE Band 13	0.271	0.031	0.636	0.302	0.907	0.938
	LTE Band 5	0.729	0.031	0.636	0.760	1.365	1.396

Simul Tx	Configuration	GPRS 1900 SAR (W/kg)	Bluetooth Ant.1 SAR (W/kg)	5.8G W-LAN Ant.1 SAR (W/kg)	ΣSAR (W/kg)		
		1	2	3	1+2	1+3	1+2+3
Body-Worn SAR	Front	0.989	0.035	0.070	1.024	1.059	1.094
	Rear	0.873	0.031	0.636	0.904	1.509	1.540

Note : The above simultaneous result is the worst case result for 2G/3G/4G + Bluetooth Ant1 + 5.8G WLAN Ant1 simultaneous case for body worn.

Table 13.5.19 Simultaneous Transmission Scenario for 2G/3G/4G with Bluetooth Ant.1 and 5.3 GHz Ant.2 W-LAN (Body-Worn at 10 mm)

Exposure Condition	Mode	2G/3G/4G SAR (W/kg)	Bluetooth Ant.1 SAR (W/kg)	5.3G W-LAN Ant.2 SAR (W/kg)	ΣSAR (W/kg)		
		1	2	3	1+2	1+3	1+2+3
Body-Worn SAR	GSM 850	0.577	0.031	0.333	0.608	0.910	0.941
	GPRS 850	0.746	0.031	0.333	0.777	1.079	1.110
	GSM 1900	0.678	0.031	0.333	0.709	1.011	1.042
	GPRS 1900	0.873	0.031	0.333	0.904	1.206	1.237
	WCDMA 850	0.759	0.031	0.333	0.790	1.092	1.123
	WCDMA 1700	0.490	0.031	0.333	0.521	0.823	0.854
	WCDMA 1900	0.862	0.031	0.333	0.893	1.195	1.226
	LTE Band 17	0.458	0.031	0.333	0.489	0.791	0.822
	LTE Band 13	0.271	0.031	0.333	0.302	0.604	0.635
LTE Band 5	0.729	0.031	0.333	0.760	1.062	1.093	

Simul Tx	Configuration	GPRS 1900 SAR (W/kg)	Bluetooth Ant.1 SAR (W/kg)	5.3G W-LAN Ant.2 SAR (W/kg)	ΣSAR (W/kg)		
		1	2	3	1+2	1+3	1+2+3
Body-Worn SAR	Front	0.989	0.035	0.059	1.024	1.048	1.083
	Rear	0.873	0.031	0.333	0.904	1.206	1.237

Note : The above simultaneous result is the worst case result for 2G/3G/4G + Bluetooth Ant1 + 5.3G WLAN Ant2 simultaneous case for body worn.

Table 13.5.20 Simultaneous Transmission Scenario for 2G/3G/4G with Bluetooth Ant.1 and 5.6 GHz Ant.2 W-LAN (Body-Worn at 10 mm)

Exposure Condition	Mode	2G/3G/4G SAR (W/kg)	Bluetooth Ant.1 SAR (W/kg)	5.6G W-LAN Ant.2 SAR (W/kg)	ΣSAR (W/kg)		
		1	2	3	1+2	1+3	1+2+3
Body-Worn SAR	GSM 850	0.577	0.031	0.315	0.608	0.892	0.923
	GPRS 850	0.746	0.031	0.315	0.777	1.061	1.092
	GSM 1900	0.678	0.031	0.315	0.709	0.993	1.024
	GPRS 1900	0.873	0.031	0.315	0.904	1.188	1.219
	WCDMA 850	0.759	0.031	0.315	0.790	1.074	1.105
	WCDMA 1700	0.490	0.031	0.315	0.521	0.805	0.836
	WCDMA 1900	0.862	0.031	0.315	0.893	1.177	1.208
	LTE Band 17	0.458	0.031	0.315	0.489	0.773	0.804
	LTE Band 13	0.271	0.031	0.315	0.302	0.586	0.617
	LTE Band 5	0.729	0.031	0.315	0.760	1.044	1.075

Simul Tx	Configuration	GPRS 1900 SAR (W/kg)	Bluetooth Ant.1 SAR (W/kg)	5.6G W-LAN Ant.2 SAR (W/kg)	ΣSAR (W/kg)		
		1	2	3	1+2	1+3	1+2+3
Body-Worn SAR	Front	0.989	0.035	0.035	1.024	1.024	1.059
	Rear	0.873	0.031	0.315	0.904	1.188	1.219

Note : The above simultaneous result is the worst case result for 2G/3G/4G + Bluetooth Ant1 + 5.6G WLAN Ant2 simultaneous case for body worn.

Table 13.5.21 Simultaneous Transmission Scenario for 2G/3G/4G with Bluetooth Ant.1 and 5.8 GHz Ant.2 W-LAN (Body-Worn at 10 mm)

Exposure Condition	Mode	2G/3G/4G SAR (W/kg)	Bluetooth Ant.1 SAR (W/kg)	5.8G W-LAN Ant.2 SAR (W/kg)	ΣSAR (W/kg)		
		1	2	3	1+2	1+3	1+2+3
Body-Worn SAR	GSM 850	0.577	0.031	0.181	0.608	0.758	0.789
	GPRS 850	0.746	0.031	0.181	0.777	0.927	0.958
	GSM 1900	0.678	0.031	0.181	0.709	0.859	0.890
	GPRS 1900	0.873	0.031	0.181	0.904	1.054	1.085
	WCDMA 850	0.759	0.031	0.181	0.790	0.940	0.971
	WCDMA 1700	0.490	0.031	0.181	0.521	0.671	0.702
	WCDMA 1900	0.862	0.031	0.181	0.893	1.043	1.074
	LTE Band 17	0.458	0.031	0.181	0.489	0.639	0.670
	LTE Band 13	0.271	0.031	0.181	0.302	0.452	0.483
	LTE Band 5	0.729	0.031	0.181	0.760	0.910	0.941

Simul Tx	Configuration	GPRS 1900 SAR (W/kg)	Bluetooth Ant.1 SAR (W/kg)	5.8G W-LAN Ant.2 SAR (W/kg)	ΣSAR (W/kg)		
		1	2	3	1+2	1+3	1+2+3
Body-Worn SAR	Front	0.989	0.035	0.016	1.024	1.005	1.040
	Rear	0.873	0.031	0.181	0.904	1.054	1.085

Note : The above simultaneous result is the worst case result for 2G/3G/4G + Bluetooth Ant1 + 5.8G WLAN Ant2 simultaneous case for body worn.

Table 13.5.22 Simultaneous Transmission Scenario for 2G/3G/4G with Bluetooth Ant.1 and 5.3 GHz MIMO W-LAN (Body-Worn at 10 mm)

Exposure Condition	Mode	2G/3G/4G SAR (W/kg)	Bluetooth Ant.1 SAR (W/kg)	5.3G W-LAN MIMO SAR (W/kg)	ΣSAR (W/kg)		
		1	2	3	1+2	1+3	1+2+3
Body-Worn SAR	GSM 850	0.577	0.031	0.567	0.608	1.144	1.175
	GPRS 850	0.746	0.031	0.567	0.777	1.313	1.344
	GSM 1900	0.678	0.031	0.567	0.709	1.245	1.276
	GPRS 1900	0.873	0.031	0.567	0.904	1.440	1.471
	WCDMA 850	0.759	0.031	0.567	0.790	1.326	1.357
	WCDMA 1700	0.490	0.031	0.567	0.521	1.057	1.088
	WCDMA 1900	0.862	0.031	0.567	0.893	1.429	1.460
	LTE Band 17	0.458	0.031	0.567	0.489	1.025	1.056
	LTE Band 13	0.271	0.031	0.567	0.302	0.838	0.869
	LTE Band 5	0.729	0.031	0.567	0.760	1.296	1.327

Simul Tx	Configuration	GPRS 1900 SAR (W/kg)	Bluetooth Ant.1 SAR (W/kg)	5.3G W-LAN MIMO SAR (W/kg)	ΣSAR (W/kg)		
		1	2	3	1+2	1+3	1+2+3
Body-Worn SAR	Front	0.989	0.035	0.092	1.024	1.081	1.116
	Rear	0.873	0.031	0.567	0.904	1.440	1.471

Note : The above simultaneous result is the worst case result for 2G/3G/4G + Bluetooth Ant1 + 5.3G WLAN MIMO simultaneous case for body worn.

Table 13.5.23 Simultaneous Transmission Scenario for 2G/3G/4G with Bluetooth Ant.1 and 5.6 GHz MIMO W-LAN (Body-Worn at 10 mm)

Exposure Condition	Mode	2G/3G/4G SAR (W/kg)	Bluetooth Ant.1 SAR (W/kg)	5.6G W-LAN MIMO SAR (W/kg)	ΣSAR (W/kg)		
		1	2	3	1+2	1+3	1+2+3
Body-Worn SAR	GSM 850	0.577	0.031	0.504	0.608	1.081	1.112
	GPRS 850	0.746	0.031	0.504	0.777	1.250	1.281
	GSM 1900	0.678	0.031	0.504	0.709	1.182	1.213
	GPRS 1900	0.873	0.031	0.504	0.904	1.377	1.408
	WCDMA 850	0.759	0.031	0.504	0.790	1.263	1.294
	WCDMA 1700	0.490	0.031	0.504	0.521	0.994	1.025
	WCDMA 1900	0.862	0.031	0.504	0.893	1.366	1.397
	LTE Band 17	0.458	0.031	0.504	0.489	0.962	0.993
	LTE Band 13	0.271	0.031	0.504	0.302	0.775	0.806
	LTE Band 5	0.729	0.031	0.504	0.760	1.233	1.264

Simul Tx	Configuration	GPRS 1900 SAR (W/kg)	Bluetooth Ant.1 SAR (W/kg)	5.6G W-LAN MIMO SAR (W/kg)	ΣSAR (W/kg)		
		1	2	3	1+2	1+3	1+2+3
Body-Worn SAR	Front	0.989	0.035	0.075	1.024	1.064	1.099
	Rear	0.873	0.031	0.504	0.904	1.377	1.408

Note : The above simultaneous result is the worst case result for 2G/3G/4G + Bluetooth Ant1 + 5.6G WLAN MIMO simultaneous case for body worn.

Table 13.5.24 Simultaneous Transmission Scenario for 2G/3G/4G with Bluetooth Ant.1 and 5.8 GHz MIMO W-LAN (Body-Worn at 10 mm)

Exposure Condition	Mode	2G/3G/4G SAR (W/kg)	Bluetooth Ant.1 SAR (W/kg)	5.8G W-LAN MIMO SAR (W/kg)	ΣSAR (W/kg)		
		1	2	3	1+2	1+3	1+2+3
Body-Worn SAR	GSM 850	0.577	0.031	0.527	0.608	1.104	1.135
	GPRS 850	0.746	0.031	0.527	0.777	1.273	1.304
	GSM 1900	0.678	0.031	0.527	0.709	1.205	1.236
	GPRS 1900	0.873	0.031	0.527	0.904	1.400	1.431
	WCDMA 850	0.759	0.031	0.527	0.790	1.286	1.317
	WCDMA 1700	0.490	0.031	0.527	0.521	1.017	1.048
	WCDMA 1900	0.862	0.031	0.527	0.893	1.389	1.420
	LTE Band 17	0.458	0.031	0.527	0.489	0.985	1.016
	LTE Band 13	0.271	0.031	0.527	0.302	0.798	0.829
	LTE Band 5	0.729	0.031	0.527	0.760	1.256	1.287

Simul Tx	Configuration	GPRS 1900 SAR (W/kg)	Bluetooth Ant.1 SAR (W/kg)	5.8G W-LAN MIMO SAR (W/kg)	ΣSAR (W/kg)		
		1	2	3	1+2	1+3	1+2+3
Body-Worn SAR	Front	0.989	0.035	0.075	1.024	1.064	1.099
	Rear	0.873	0.031	0.527	0.904	1.400	1.431

Note : The above simultaneous result is the worst case result for 2G/3G/4G + Bluetooth Ant1 + 5.8G WLAN MIMO simultaneous case for body worn.

Table 13.5.25 Simultaneous Transmission Scenario for 2.4 GHz Ant.1 and 5 GHz Ant.2 W-LAN (Body-Worn at 10 mm)

Simul Tx	Configuration	2.4G W-LAN Ant.1 SAR (W/kg)	5.3G W-LAN Ant.2 SAR (W/kg)	ΣSAR (W/kg)
		1	2	1+2
Body-Worn SAR	Front	0.107	0.059	0.166
	Rear	0.104	0.333	0.437

Simul Tx	Configuration	2.4G W-LAN Ant.1 SAR (W/kg)	5.6G W-LAN Ant.2 SAR (W/kg)	ΣSAR (W/kg)
		1	2	1+2
Body-Worn SAR	Front	0.107	0.035	0.142
	Rear	0.104	0.315	0.419

Simul Tx	Configuration	2.4G W-LAN Ant.1 SAR (W/kg)	5.8G W-LAN Ant.2 SAR (W/kg)	ΣSAR (W/kg)
		1	2	1+2
Body-Worn SAR	Front	0.107	0.016	0.123
	Rear	0.104	0.181	0.285

Note : The above simultaneous result is the worst case result for 2.4G WLAN Ant1 + 5G WLAN Ant2 simultaneous case for body worn.

Table 13.5.26 Simultaneous Transmission Scenario for Bluetooth Ant.1 and 5 GHz Ant.1 W-LAN (Body-Worn at 10 mm)

Simul Tx	Configuration	Bluetooth Ant.1 SAR (W/kg)	5.3G W-LAN Ant.1 SAR (W/kg)	ΣSAR (W/kg)
		1	2	1+2
Body-Worn SAR	Front	0.035	0.041	0.076
	Rear	0.031	0.550	0.581

Simul Tx	Configuration	Bluetooth Ant.1 SAR (W/kg)	5.6G W-LAN Ant.1 SAR (W/kg)	ΣSAR (W/kg)
		1	2	1+2
Body-Worn SAR	Front	0.035	0.047	0.082
	Rear	0.031	0.478	0.509

Simul Tx	Configuration	Bluetooth Ant.1 SAR (W/kg)	5.8G W-LAN Ant.1 SAR (W/kg)	ΣSAR (W/kg)
		1	2	1+2
Body-Worn SAR	Front	0.035	0.070	0.105
	Rear	0.031	0.636	0.667

Note : The above simultaneous result is the worst case result for Bluetooth Ant1 + 5G WLAN Ant1 simultaneous case for body worn.

Table 13.5.27 Simultaneous Transmission Scenario for Bluetooth Ant.1 and 5 GHz Ant.2 W-LAN (Body-Worn at 10 mm)

Simul Tx	Configuration	Bluetooth Ant.1 SAR (W/kg)	5.3G W-LAN Ant.2 SAR (W/kg)	Σ SAR (W/kg)
		1	2	1+2
Body-Worn SAR	Front	0.035	0.059	0.094
	Rear	0.031	0.333	0.364

Simul Tx	Configuration	Bluetooth Ant.1 SAR (W/kg)	5.6G W-LAN Ant.2 SAR (W/kg)	Σ SAR (W/kg)
		1	2	1+2
Body-Worn SAR	Front	0.035	0.035	0.070
	Rear	0.031	0.315	0.346

Simul Tx	Configuration	Bluetooth Ant.1 SAR (W/kg)	5.8G W-LAN Ant.2 SAR (W/kg)	Σ SAR (W/kg)
		1	2	1+2
Body-Worn SAR	Front	0.035	0.016	0.051
	Rear	0.031	0.181	0.212

Note : The above simultaneous result is the worst case result for Bluetooth Ant1 + 5G WLAN Ant2 simultaneous case for body worn.

Table 13.5.28 Simultaneous Transmission Scenario for Bluetooth Ant.1 and 5 GHz MIMO W-LAN (Body-Worn at 10 mm)

Simul Tx	Configuration	Bluetooth Ant.1 SAR (W/kg)	5.3G W-LAN MIMO SAR (W/kg)	Σ SAR (W/kg)
		1	2	1+2
Body-Worn SAR	Front	0.035	0.092	0.127
	Rear	0.031	0.567	0.598

Simul Tx	Configuration	Bluetooth Ant.1 SAR (W/kg)	5.6G W-LAN MIMO SAR (W/kg)	Σ SAR (W/kg)
		1	2	1+2
Body-Worn SAR	Front	0.035	0.075	0.110
	Rear	0.031	0.504	0.535

Simul Tx	Configuration	Bluetooth Ant.1 SAR (W/kg)	5.8G W-LAN MIMO SAR (W/kg)	Σ SAR (W/kg)
		1	2	1+2
Body-Worn SAR	Front	0.035	0.075	0.110
	Rear	0.031	0.527	0.558

Note : The above simultaneous result is the worst case result for Bluetooth Ant1 + 5G WLAN MIMO simultaneous case for body worn.

Table 13.5.29 Simultaneous Transmission Scenario for 2G/3G/4G with Bluetooth (Body-Worn at 10 mm)

Exposure Condition	Mode	2G/3G/4G SAR (W/kg)	Bluetooth SAR (W/kg)	Σ SAR (W/kg)
		1	2	1+2
Body-Worn SAR	GSM 850	0.577	0.031	0.608
	GPRS 850	0.746	0.031	0.777
	GSM 1900	0.715	0.035	0.750
	GPRS 1900	0.989	0.035	1.024
	WCDMA 850	0.759	0.031	0.790
	WCDMA 1700	0.500	0.035	0.535
	WCDMA 1900	0.956	0.035	0.991
	LTE Band 17	0.458	0.031	0.489
	LTE Band 13	0.271	0.031	0.302
LTE Band 5	0.729	0.031	0.760	

Simul Tx	Configuration	GPRS 1900 SAR (W/kg)	Bluetooth SAR (W/kg)	Σ SAR (W/kg)
		1	2	1+2
Body-Worn SAR	Front	0.989	0.035	1.024
	Rear	0.873	0.031	0.904

Note : The above simultaneous result is the worst case result for 2G/3G/4G + Bluetooth simultaneous case for body worn.

13.6 Hotspot SAR Simultaneous Transmission Analysis

Per FCC KDB Publication 941225 D06v02r01, the device edges with antennas more than 2.5 cm from edge are not required to be evaluated for SAR ("-").

All simultaneous cases were investigated and the worst case simultaneous results are reported for each band/mode/configuration.

Table 13.6.1 Simultaneous Transmission Scenario for 2G/3G/4G with 2.4 GHz W-LAN (Hotspot at 10 mm)

Exposure Condition	Mode	2G/3G/4G SAR (W/kg)	2.4G W-LAN Ant.1 SAR (W/kg)	ΣSAR (W/kg)
		1	2	1+2
Hotspot SAR	GPRS 850	0.746	0.104	0.850
	GPRS 1900	0.989	0.107	1.096
	WCDMA 850	0.759	0.104	0.863
	WCDMA 1700	0.500	0.107	0.607
	WCDMA 1900	0.956	0.107	1.063
	LTE Band 12	0.458	0.104	0.562
	LTE Band 17	0.271	0.104	0.375
	LTE Band 5	0.729	0.104	0.833

Simul Tx	Configuration	GPRS 1900 SAR (W/kg)	2.4G W-LAN Ant.1 SAR (W/kg)	ΣSAR (W/kg)
		1	2	1+2
Hotspot SAR	Top	-	0.027	0.027
	Bottom	0.987	-	0.987
	Front	0.989	0.107	1.096
	Rear	0.873	0.104	0.977
	Right	-	-	-
	Left	0.486	0.111	0.597

Note : The above simultaneous result is the worst case result for 2G/3G/4G + 2.4G WLAN Ant1 simultaneous case for Hotspot.

Table 13.6.2 Simultaneous Transmission Scenario for 2G/3G/4G with 2.4 GHz W-LAN (Hotspot at 10 mm)

Exposure Condition	Mode	2G/3G/4G SAR (W/kg)	2.4G W-LAN Ant.2 SAR (W/kg)	Σ SAR (W/kg)
		1	2	1+2
Hotspot SAR	GPRS 850	0.746	0.127	0.873
	GPRS 1900	0.989	0.121	1.110
	WCDMA 850	0.759	0.127	0.886
	WCDMA 1700	0.500	0.121	0.621
	WCDMA 1900	0.956	0.121	1.077
	LTE Band 17	0.458	0.127	0.585
	LTE Band 13	0.271	0.127	0.398
	LTE Band 5	0.729	0.127	0.856

Simul Tx	Configuration	GPRS 1900 SAR (W/kg)	2.4G W-LAN Ant.2 SAR (W/kg)	Σ SAR (W/kg)
		1	2	1+2
Hotspot SAR	Top	-	0.159	0.159
	Bottom	0.987	-	0.987
	Front	0.989	0.121	1.110
	Rear	0.873	0.127	1.000
	Right	-	-	-
	Left	0.486	0.019	0.505

Note : The above simultaneous result is the worst case result for 2G/3G/4G + 2.4G WLAN Ant2 simultaneous case for Hotspot.

Table 13.6.3 Simultaneous Transmission Scenario for 2G/3G/4G with 2.4 GHz W-LAN (Hotspot at 10 mm)

Exposure Condition	Mode	2G/3G/4G SAR (W/kg)	2.4G W-LAN MIMO SAR (W/kg)	Σ SAR (W/kg)
		1	2	1+2
Hotspot SAR	GPRS 850	0.746	0.183	0.929
	GPRS 1900	0.989	0.159	1.148
	WCDMA 850	0.759	0.183	0.942
	WCDMA 1700	0.490	0.183	0.673
	WCDMA 1900	0.956	0.159	1.115
	LTE Band 17	0.458	0.183	0.641
	LTE Band 13	0.271	0.183	0.454
	LTE Band 5	0.729	0.183	0.912

Simul Tx	Configuration	GPRS 1900 SAR (W/kg)	2.4G W-LAN MIMO SAR (W/kg)	Σ SAR (W/kg)
		1	2	1+2
Hotspot SAR	Top	-	0.191	0.191
	Bottom	0.987	-	0.987
	Front	0.989	0.159	1.148
	Rear	0.873	0.183	1.056
	Right	-	-	-
	Left	0.486	0.150	0.636

Note : The above simultaneous result is the worst case result for 2G/3G/4G + 2.4G WLAN MIMO simultaneous case for Hotspot.

Table 13.6.4 Simultaneous Transmission Scenario for 2G/3G/4G with 5.2 GHz W-LAN (Hotspot at 10 mm)

Exposure Condition	Mode	2G/3G/4G SAR (W/kg)	5.2G W-LAN Ant.1 SAR (W/kg)	Σ SAR (W/kg)
		1	2	1+2
Hotspot SAR	GPRS 850	0.746	0.532	1.278
	GPRS 1900	0.873	0.532	1.405
	WCDMA 850	0.759	0.532	1.291
	WCDMA 1700	0.490	0.532	1.022
	WCDMA 1900	0.862	0.532	1.394
	LTE Band 17	0.458	0.532	0.990
	LTE Band 13	0.271	0.532	0.803
	LTE Band 5	0.729	0.532	1.261

Simul Tx	Configuration	GPRS 1900 SAR (W/kg)	5.2G W-LAN Ant.1 SAR (W/kg)	Σ SAR (W/kg)
		1	2	1+2
Hotspot SAR	Top	-	0.101	0.101
	Bottom	0.987	-	0.987
	Front	0.989	0.040	1.029
	Rear	0.873	0.532	1.405
	Right	-	-	-
	Left	0.486	0.254	0.740

Note : The above simultaneous result is the worst case result for 2G/3G/4G + 5.2G WLAN Ant1 simultaneous case for Hotspot.

Table 13.6.5 Simultaneous Transmission Scenario for 2G/3G/4G with 5.2 GHz W-LAN (Hotspot at 10 mm)

Exposure Condition	Mode	2G/3G/4G SAR (W/kg)	5.2G W-LAN Ant.2 SAR (W/kg)	Σ SAR (W/kg)
		1	2	1+2
Hotspot SAR	GPRS 850	0.746	0.328	1.074
	GPRS 1900	0.873	0.328	1.201
	WCDMA 850	0.759	0.328	1.087
	WCDMA 1700	0.490	0.328	0.818
	WCDMA 1900	0.862	0.328	1.190
	LTE Band 17	0.458	0.328	0.786
	LTE Band 13	0.271	0.328	0.599
	LTE Band 5	0.729	0.328	1.057

Simul Tx	Configuration	GPRS 1900 SAR (W/kg)	5.2G W-LAN Ant.2 SAR (W/kg)	Σ SAR (W/kg)
		1	2	1+2
Hotspot SAR	Top	-	0.116	0.116
	Bottom	0.987	-	0.987
	Front	0.989	0.058	1.047
	Rear	0.873	0.328	1.201
	Right	-	-	-
	Left	0.486	0.056	0.542

Note : The above simultaneous result is the worst case result for 2G/3G/4G + 5.2G WLAN Ant2 simultaneous case for Hotspot.

Table 13.6.6 Simultaneous Transmission Scenario for 2G/3G/4G with 5.2 GHz W-LAN (Hotspot at 10 mm)

Exposure Condition	Mode	2G/3G/4G SAR (W/kg)	5.2G W-LAN MIMO SAR (W/kg)	Σ SAR (W/kg)
		1	2	1+2
Hotspot SAR	GPRS 850	0.746	0.586	1.332
	GPRS 1900	0.873	0.586	1.459
	WCDMA 850	0.759	0.586	1.345
	WCDMA 1700	0.490	0.586	1.076
	WCDMA 1900	0.862	0.586	1.448
	LTE Band 17	0.458	0.586	1.044
	LTE Band 13	0.271	0.586	0.857
	LTE Band 5	0.729	0.586	1.315

Simul Tx	Configuration	GPRS 1900 SAR (W/kg)	5.2G W-LAN MIMO SAR (W/kg)	Σ SAR (W/kg)
		1	2	1+2
Hotspot SAR	Top	-	0.209	0.209
	Bottom	0.987	-	0.987
	Front	0.989	0.089	1.078
	Rear	0.873	0.586	1.459
	Right	-	-	-
	Left	0.486	0.279	0.765

Note : The above simultaneous result is the worst case result for 2G/3G/4G + 5.2G WLAN MIMO simultaneous case for Hotspot.

Table 13.6.7 Simultaneous Transmission Scenario for 2G/3G/4G with 5.8 GHz W-LAN (Hotspot at 10 mm)

Exposure Condition	Mode	2G/3G/4G SAR (W/kg)	5.8G W-LAN Ant.1 SAR (W/kg)	Σ SAR (W/kg)
		1	2	1+2
Hotspot SAR	GPRS 850	0.746	0.636	1.382
	GPRS 1900	0.873	0.636	1.509
	WCDMA 850	0.759	0.636	1.395
	WCDMA 1700	0.490	0.636	1.126
	WCDMA 1900	0.862	0.636	1.498
	LTE Band 17	0.458	0.636	1.094
	LTE Band 13	0.271	0.636	0.907
	LTE Band 5	0.729	0.636	1.365

Simul Tx	Configuration	GPRS 1900 SAR (W/kg)	5.8G W-LAN Ant.1 SAR (W/kg)	Σ SAR (W/kg)
		1	2	1+2
Hotspot SAR	Top	-	0.060	0.060
	Bottom	0.987	-	0.987
	Front	0.989	0.070	1.059
	Rear	0.873	0.636	1.509
	Right	-	-	-
	Left	0.486	0.317	0.803

Note : The above simultaneous result is the worst case result for 2G/3G/4G + 5.8G WLAN Ant1 simultaneous case for Hotspot.

Table 13.6.8 Simultaneous Transmission Scenario for 2G/3G/4G with 5.8 GHz W-LAN (Hotspot at 10 mm)

Exposure Condition	Mode	2G/3G/4G SAR (W/kg)	5.8G W-LAN Ant.2 SAR (W/kg)	Σ SAR (W/kg)
		1	2	1+2
Hotspot SAR	GPRS 850	0.746	0.181	0.927
	GPRS 1900	0.873	0.181	1.054
	WCDMA 850	0.759	0.181	0.940
	WCDMA 1700	0.490	0.181	0.671
	WCDMA 1900	0.862	0.181	1.043
	LTE Band 17	0.458	0.181	0.639
	LTE Band 13	0.271	0.181	0.452
	LTE Band 5	0.729	0.181	0.910

Simul Tx	Configuration	GPRS 1900 SAR (W/kg)	5.8G W-LAN Ant.2 SAR (W/kg)	Σ SAR (W/kg)
		1	2	1+2
Hotspot SAR	Top	-	0.152	0.152
	Bottom	0.987	-	0.987
	Front	0.989	0.016	1.005
	Rear	0.873	0.181	1.054
	Right	-	-	-
	Left	0.486	0.016	0.502

Note : The above simultaneous result is the worst case result for 2G/3G/4G + 5.8G WLAN Ant2 simultaneous case for Hotspot.

Table 13.6.9 Simultaneous Transmission Scenario for 2G/3G/4G with 5.8 GHz W-LAN (Hotspot at 10 mm)

Exposure Condition	Mode	2G/3G/4G SAR (W/kg)	5.8G W-LAN MIMO SAR (W/kg)	Σ SAR (W/kg)
		1	2	1+2
Hotspot SAR	GPRS 850	0.746	0.527	1.273
	GPRS 1900	0.873	0.527	1.400
	WCDMA 850	0.759	0.527	1.286
	WCDMA 1700	0.490	0.527	1.017
	WCDMA 1900	0.862	0.527	1.389
	LTE Band 17	0.458	0.527	0.985
	LTE Band 13	0.271	0.527	0.798
	LTE Band 5	0.729	0.527	1.256

Simul Tx	Configuration	GPRS 1900 SAR (W/kg)	5.8G W-LAN MIMO SAR (W/kg)	Σ SAR (W/kg)
		1	2	1+2
Hotspot SAR	Top	-	0.177	0.177
	Bottom	0.987	-	0.987
	Front	0.989	0.075	1.064
	Rear	0.873	0.527	1.400
	Right	-	-	-
	Left	0.486	0.338	0.824

Note : The above simultaneous result is the worst case result for 2G/3G/4G + 5.8G WLAN MIMO simultaneous case for Hotspot.

Table 13.6.10 Simultaneous Transmission Scenario for 2G/3G/4G with 2.4 GHz Ant.1 and 5.2 GHz Ant.2 W-LAN (Hotspot at 10 mm)

Exposure Condition	Mode	2G/3G/4G SAR (W/kg)	2.4G W-LAN Ant.1 SAR (W/kg)	5.2G W-LAN Ant.2 SAR (W/kg)	ΣSAR (W/kg)		
		1	2	3	1+2	1+3	1+2+3
Hotspot SAR	GPRS 850	0.746	0.104	0.328	0.850	1.074	1.178
	GPRS 1900	0.873	0.104	0.328	0.977	1.201	1.305
	WCDMA 850	0.759	0.104	0.328	0.863	1.087	1.191
	WCDMA 1700	0.490	0.104	0.328	0.594	0.818	0.922
	WCDMA 1900	0.862	0.104	0.328	0.966	1.190	1.294
	LTE Band 17	0.458	0.104	0.328	0.562	0.786	0.890
	LTE Band 13	0.271	0.104	0.328	0.375	0.599	0.703
	LTE Band 5	0.729	0.104	0.328	0.833	1.057	1.161

Simul Tx	Configuration	GPRS 1900 SAR (W/kg)	2.4G W-LAN Ant.1 SAR (W/kg)	5.2G W-LAN Ant.2 SAR (W/kg)	ΣSAR (W/kg)		
		1	2	3	1+2	1+3	1+2+3
Hotspot SAR	Top	-	0.027	0.116	0.027	0.116	0.143
	Bottom	0.987	-	-	0.987	0.987	0.987
	Front	0.989	0.107	0.058	1.096	1.047	1.154
	Rear	0.873	0.104	0.328	0.977	1.201	1.305
	Right	-	-	-	-	-	-
	Left	0.486	0.111	0.056	0.597	0.542	0.653

Note : The above simultaneous result is the worst case result for 2G/3G/4G + 2.4G WLAN Ant1 + 5.2G WLAN Ant2 simultaneous case for Hotspot.

Table 13.6.11 Simultaneous Transmission Scenario for 2G/3G/4G with 2.4 GHz Ant.1 and 5.8 GHz Ant.2 W-LAN (Hotspot at 10 mm)

Exposure Condition	Mode	2G/3G/4G SAR (W/kg)	2.4G W-LAN Ant.1 SAR (W/kg)	5.8G W-LAN Ant.2 SAR (W/kg)	ΣSAR (W/kg)		
		1	2	3	1+2	1+3	1+2+3
Hotspot SAR	GPRS 850	0.746	0.104	0.181	0.850	0.927	1.031
	GPRS 1900	0.873	0.104	0.181	0.977	1.054	1.158
	WCDMA 850	0.759	0.104	0.181	0.863	0.940	1.044
	WCDMA 1700	0.490	0.104	0.181	0.594	0.671	0.775
	WCDMA 1900	0.862	0.104	0.181	0.966	1.043	1.147
	LTE Band 17	0.458	0.104	0.181	0.562	0.639	0.743
	LTE Band 13	0.271	0.104	0.181	0.375	0.452	0.556
	LTE Band 5	0.729	0.104	0.181	0.833	0.910	1.014

Simul Tx	Configuration	GPRS 1900 SAR (W/kg)	2.4G W-LAN Ant.1 SAR (W/kg)	5.8G W-LAN Ant.2 SAR (W/kg)	ΣSAR (W/kg)		
		1	2	3	1+2	1+3	1+2+3
Hotspot SAR	Top	-	0.027	0.152	0.027	0.152	0.179
	Bottom	0.987	-	-	0.987	0.987	0.987
	Front	0.989	0.107	0.016	1.096	1.005	1.112
	Rear	0.873	0.104	0.181	0.977	1.054	1.158
	Right	-	-	-	-	-	-
	Left	0.486	0.111	0.016	0.597	0.502	0.613

Note : The above simultaneous result is the worst case result for 2G/3G/4G + 2.4G WLAN Ant1 + 5.8G WLAN Ant2 simultaneous case for Hotspot.

Table 13.6.12 Simultaneous Transmission Scenario for 2G/3G/4G with Bluetooth Ant.1 and 5.2 GHz Ant.1 W-LAN (Hotspot at 10 mm)

Exposure Condition	Mode	2G/3G/4G SAR (W/kg)	Bluetooth Ant.1 SAR (W/kg)	5.2G W-LAN Ant.1 SAR (W/kg)	ΣSAR (W/kg)		
		1	2	3	1+2	1+3	1+2+3
Hotspot SAR	GPRS 850	0.746	0.031	0.532	0.777	1.278	1.309
	GPRS 1900	0.873	0.031	0.532	0.904	1.405	1.436
	WCDMA 850	0.759	0.031	0.532	0.790	1.291	1.322
	WCDMA 1700	0.490	0.031	0.532	0.521	1.022	1.053
	WCDMA 1900	0.862	0.031	0.532	0.893	1.394	1.425
	LTE Band 17	0.458	0.031	0.532	0.489	0.990	1.021
	LTE Band 13	0.271	0.031	0.532	0.302	0.803	0.834
	LTE Band 5	0.729	0.031	0.532	0.760	1.261	1.292

Simul Tx	Configuration	GPRS 1900 SAR (W/kg)	Bluetooth Ant.1 SAR (W/kg)	5.2G W-LAN Ant.1 SAR (W/kg)	ΣSAR (W/kg)		
		1	2	3	1+2	1+3	1+2+3
Hotspot SAR	Top	-	0.017	0.101	0.017	0.101	0.118
	Bottom	0.987	-	-	0.987	0.987	0.987
	Front	0.989	0.035	0.040	1.024	1.029	1.064
	Rear	0.873	0.031	0.532	0.904	1.405	1.436
	Right	-	-	-	-	-	-
	Left	0.486	0.056	0.254	0.542	0.740	0.796

Note : The above simultaneous result is the worst case result for 2G/3G/4G + Bluetooth Ant1 + 5.2G WLAN Ant1 simultaneous case for Hotspot.

Table 13.6.13 Simultaneous Transmission Scenario for 2G/3G/4G with Bluetooth Ant.1 and 5.8 GHz Ant.1 W-LAN (Hotspot at 10 mm)

Exposure Condition	Mode	2G/3G/4G SAR (W/kg)	Bluetooth Ant.1 SAR (W/kg)	5.8G W-LAN Ant.1 SAR (W/kg)	ΣSAR (W/kg)		
		1	2	3	1+2	1+3	1+2+3
Hotspot SAR	GPRS 850	0.746	0.031	0.636	0.777	1.382	1.413
	GPRS 1900	0.873	0.031	0.636	0.904	1.509	1.540
	WCDMA 850	0.759	0.031	0.636	0.790	1.395	1.426
	WCDMA 1700	0.490	0.031	0.636	0.521	1.126	1.157
	WCDMA 1900	0.862	0.031	0.636	0.893	1.498	1.529
	LTE Band 17	0.458	0.031	0.636	0.489	1.094	1.125
	LTE Band 13	0.271	0.031	0.636	0.302	0.907	0.938
	LTE Band 5	0.729	0.031	0.636	0.760	1.365	1.396

Simul Tx	Configuration	GPRS 1900 SAR (W/kg)	Bluetooth Ant.1 SAR (W/kg)	5.8G W-LAN Ant.1 SAR (W/kg)	ΣSAR (W/kg)		
		1	2	3	1+2	1+3	1+2+3
Hotspot SAR	Top	-	0.017	0.060	0.017	0.060	0.077
	Bottom	0.987	-	-	0.987	0.987	0.987
	Front	0.989	0.035	0.070	1.024	1.059	1.094
	Rear	0.873	0.031	0.636	0.904	1.509	1.540
	Right	-	-	-	-	-	-
	Left	0.486	0.056	0.317	0.542	0.803	0.859

Note : The above simultaneous result is the worst case result for 2G/3G/4G + Bluetooth Ant1 + 5.8G WLAN Ant1 simultaneous case for Hotspot.

Table 13.6.14 Simultaneous Transmission Scenario for 2G/3G/4G with Bluetooth Ant.1 and 5.2 GHz Ant.2 W-LAN (Hotspot at 10 mm)

Exposure Condition	Mode	2G/3G/4G SAR (W/kg)	Bluetooth Ant.1 SAR (W/kg)	5.2G W-LAN Ant.2 SAR (W/kg)	ΣSAR (W/kg)		
		1	2	3	1+2	1+3	1+2+3
Hotspot SAR	GPRS 850	0.746	0.031	0.328	0.777	1.074	1.105
	GPRS 1900	0.873	0.031	0.328	0.904	1.201	1.232
	WCDMA 850	0.759	0.031	0.328	0.790	1.087	1.118
	WCDMA 1700	0.490	0.031	0.328	0.521	0.818	0.849
	WCDMA 1900	0.862	0.031	0.328	0.893	1.190	1.221
	LTE Band 17	0.458	0.031	0.328	0.489	0.786	0.817
	LTE Band 13	0.271	0.031	0.328	0.302	0.599	0.630
	LTE Band 5	0.729	0.031	0.328	0.760	1.057	1.088

Simul Tx	Configuration	GPRS 1900 SAR (W/kg)	Bluetooth Ant.1 SAR (W/kg)	5.2G W-LAN Ant.2 SAR (W/kg)	ΣSAR (W/kg)		
		1	2	3	1+2	1+3	1+2+3
Hotspot SAR	Top	-	0.017	0.116	0.017	0.116	0.133
	Bottom	0.987	-	-	0.987	0.987	0.987
	Front	0.989	0.035	0.058	1.024	1.047	1.082
	Rear	0.873	0.031	0.328	0.904	1.201	1.232
	Right	-	-	-	-	-	-
	Left	0.486	0.056	0.056	0.542	0.542	0.598

Note : The above simultaneous result is the worst case result for 2G/3G/4G + Bluetooth Ant1 + 5.2G WLAN Ant2 simultaneous case for Hotspot.

Table 13.6.15 Simultaneous Transmission Scenario for 2G/3G/4G with Bluetooth Ant.1 and 5.8 GHz Ant.2 W-LAN (Hotspot at 10 mm)

Exposure Condition	Mode	2G/3G/4G SAR (W/kg)	Bluetooth Ant.1 SAR (W/kg)	5.8G W-LAN Ant.2 SAR (W/kg)	ΣSAR (W/kg)		
		1	2	3	1+2	1+3	1+2+3
Hotspot SAR	GPRS 850	0.746	0.031	0.181	0.777	0.927	0.958
	GPRS 1900	0.873	0.031	0.181	0.904	1.054	1.085
	WCDMA 850	0.759	0.031	0.181	0.790	0.940	0.971
	WCDMA 1700	0.490	0.031	0.181	0.521	0.671	0.702
	WCDMA 1900	0.862	0.031	0.181	0.893	1.043	1.074
	LTE Band 17	0.458	0.031	0.181	0.489	0.639	0.670
	LTE Band 13	0.271	0.031	0.181	0.302	0.452	0.483
	LTE Band 5	0.729	0.031	0.181	0.760	0.910	0.941

Simul Tx	Configuration	GPRS 1900 SAR (W/kg)	Bluetooth Ant.1 SAR (W/kg)	5.8G W-LAN Ant.2 SAR (W/kg)	ΣSAR (W/kg)		
		1	2	3	1+2	1+3	1+2+3
Hotspot SAR	Top	-	0.017	0.152	0.017	0.152	0.169
	Bottom	0.987	-	-	0.987	0.987	0.987
	Front	0.989	0.035	0.016	1.024	1.005	1.040
	Rear	0.873	0.031	0.181	0.904	1.054	1.085
	Right	-	-	-	-	-	-
	Left	0.486	0.056	0.016	0.542	0.502	0.558

Note : The above simultaneous result is the worst case result for 2G/3G/4G + Bluetooth Ant1 + 5.8G WLAN Ant2 simultaneous case for Hotspot.

Table 13.6.16 Simultaneous Transmission Scenario for 2G/3G/4G with Bluetooth Ant.1 and 5.2 GHz MIMO W-LAN (Hotspot at 10 mm)

Exposure Condition	Mode	2G/3G/4G SAR (W/kg)	Bluetooth Ant.1 SAR (W/kg)	5.2G W-LAN MIMO SAR (W/kg)	ΣSAR (W/kg)		
		1	2	3	1+2	1+3	1+2+3
Hotspot SAR	GPRS 850	0.746	0.031	0.586	0.777	1.332	1.363
	GPRS 1900	0.873	0.031	0.586	0.904	1.459	1.490
	WCDMA 850	0.759	0.031	0.586	0.790	1.345	1.376
	WCDMA 1700	0.490	0.031	0.586	0.521	1.076	1.107
	WCDMA 1900	0.862	0.031	0.586	0.893	1.448	1.479
	LTE Band 17	0.458	0.031	0.586	0.489	1.044	1.075
	LTE Band 13	0.271	0.031	0.586	0.302	0.857	0.888
	LTE Band 5	0.729	0.031	0.586	0.760	1.315	1.346

Simul Tx	Configuration	GPRS 1900 SAR (W/kg)	Bluetooth Ant.1 SAR (W/kg)	5.2G W-LAN MIMO SAR (W/kg)	ΣSAR (W/kg)		
		1	2	3	1+2	1+3	1+2+3
Hotspot SAR	Top	-	0.017	0.209	0.017	0.209	0.226
	Bottom	0.987	-	-	0.987	0.987	0.987
	Front	0.989	0.035	0.089	1.024	1.078	1.113
	Rear	0.873	0.031	0.586	0.904	1.459	1.490
	Right	-	-	-	-	-	-
	Left	0.486	0.056	0.279	0.542	0.765	0.821

Note : The above simultaneous result is the worst case result for 2G/3G/4G + Bluetooth Ant1 + 5.2G WLAN MIMO simultaneous case for Hotspot.

Table 13.6.17 Simultaneous Transmission Scenario for 2G/3G/4G with Bluetooth Ant.1 and 5.8 GHz MIMO W-LAN (Hotspot at 10 mm)

Exposure Condition	Mode	2G/3G/4G SAR (W/kg)	Bluetooth Ant.1 SAR (W/kg)	5.8G W-LAN MIMO SAR (W/kg)	ΣSAR (W/kg)		
		1	2	3	1+2	1+3	1+2+3
Hotspot SAR	GPRS 850	0.746	0.031	0.527	0.777	1.273	1.304
	GPRS 1900	0.873	0.031	0.527	0.904	1.400	1.431
	WCDMA 850	0.759	0.031	0.527	0.790	1.286	1.317
	WCDMA 1700	0.490	0.031	0.527	0.521	1.017	1.048
	WCDMA 1900	0.862	0.031	0.527	0.893	1.389	1.420
	LTE Band 17	0.458	0.031	0.527	0.489	0.985	1.016
	LTE Band 13	0.271	0.031	0.527	0.302	0.798	0.829
	LTE Band 5	0.729	0.031	0.527	0.760	1.256	1.287

Simul Tx	Configuration	GPRS 1900 SAR (W/kg)	Bluetooth Ant.1 SAR (W/kg)	5.8G W-LAN MIMO SAR (W/kg)	ΣSAR (W/kg)		
		1	2	3	1+2	1+3	1+2+3
Hotspot SAR	Top	-	0.017	0.177	0.017	0.177	0.194
	Bottom	0.987	-	-	0.987	0.987	0.987
	Front	0.989	0.035	0.075	1.024	1.064	1.099
	Rear	0.873	0.031	0.527	0.904	1.400	1.431
	Right	-	-	-	0.000	-	0.000
	Left	0.486	0.056	0.338	0.542	0.824	0.880

Note : The above simultaneous result is the worst case result for 2G/3G/4G + Bluetooth Ant1 + 5.8G WLAN MIMO simultaneous case for Hotspot.

Table 13.6.18 Simultaneous Transmission Scenario for 2.4 GHz Ant.1 and 5 GHz Ant.2 W-LAN (Hotspot at 10 mm)

Simul Tx	Configuration	2.4G W-LAN Ant.1 SAR (W/kg)	5.2G W-LAN Ant.2 SAR (W/kg)	ΣSAR (W/kg)
		1	2	1+2
Hotspot SAR	Top	0.027	0.116	0.143
	Bottom	-	-	-
	Front	0.107	0.058	0.165
	Rear	0.104	0.328	0.432
	Right	-	-	-
	Left	0.111	0.056	0.167

Simul Tx	Configuration	2.4G W-LAN Ant.1 SAR (W/kg)	5.8G W-LAN Ant.2 SAR (W/kg)	ΣSAR (W/kg)
		1	2	1+2
Hotspot SAR	Top	0.027	0.152	0.179
	Bottom	-	-	-
	Front	0.107	0.016	0.123
	Rear	0.104	0.181	0.285
	Right	-	-	-
	Left	0.111	0.016	0.127

Note : The above simultaneous result is the worst case result for 2.4 G WLAN Ant1 + 5 G WLAN Ant2 simultaneous case for Hotspot.

Table 13.6.19 Simultaneous Transmission Scenario for Bluetooth Ant.1 and 5 GHz Ant.1 W-LAN (Hotspot at 10 mm)

Simul Tx	Configuration	Bluetooth Ant.1 SAR (W/kg)	5.2G W-LAN Ant.1 SAR (W/kg)	ΣSAR (W/kg)
		1	2	1+2
Hotspot SAR	Top	0.017	0.101	0.118
	Bottom	-	-	-
	Front	0.035	0.040	0.075
	Rear	0.031	0.532	0.563
	Right	-	-	-
	Left	0.056	0.254	0.310

Simul Tx	Configuration	Bluetooth Ant.1 SAR (W/kg)	5.8G W-LAN Ant.1 SAR (W/kg)	ΣSAR (W/kg)
		1	2	1+2
Hotspot SAR	Top	0.017	0.060	0.077
	Bottom	-	-	-
	Front	0.035	0.070	0.105
	Rear	0.031	0.636	0.667
	Right	-	-	-
	Left	0.056	0.317	0.373

Note : The above simultaneous result is the worst case result for Bluetooth Ant1 + 5 G WLAN Ant1 simultaneous case for Hotspot.

Table 13.6.20 Simultaneous Transmission Scenario for Bluetooth Ant.1 and 5 GHz Ant.2 W-LAN (Hotspot at 10 mm)

Simul Tx	Configuration	Bluetooth Ant.1 SAR (W/kg)	5.2G W-LAN Ant.2 SAR (W/kg)	Σ SAR (W/kg)
		1	2	1+2
Hotspot SAR	Top	0.017	0.116	0.133
	Bottom	-	-	-
	Front	0.035	0.058	0.093
	Rear	0.031	0.328	0.359
	Right	-	-	-
	Left	0.056	0.056	0.112

Simul Tx	Configuration	Bluetooth Ant.1 SAR (W/kg)	5.8G W-LAN Ant.2 SAR (W/kg)	Σ SAR (W/kg)
		1	2	1+2
Hotspot SAR	Top	0.017	0.152	0.169
	Bottom	-	-	-
	Front	0.035	0.016	0.051
	Rear	0.031	0.181	0.212
	Right	-	-	-
	Left	0.056	0.016	0.072

Note : The above simultaneous result is the worst case result for Bluetooth Ant1 + 5 G WLAN Ant2 simultaneous case for Hotspot.

Table 13.6.21 Simultaneous Transmission Scenario for Bluetooth Ant.1 and 5 GHz MIMO W-LAN (Hotspot at 10 mm)

Simul Tx	Configuration	Bluetooth Ant.1 SAR (W/kg)	5.2G W-LAN MIMO SAR (W/kg)	Σ SAR (W/kg)
		1	2	1+2
Hotspot SAR	Top	0.017	0.209	0.226
	Bottom	-	-	-
	Front	0.035	0.089	0.124
	Rear	0.031	0.586	0.617
	Right	-	-	-
	Left	0.056	0.279	0.335

Simul Tx	Configuration	Bluetooth Ant.1 SAR (W/kg)	5.8G W-LAN MIMO SAR (W/kg)	Σ SAR (W/kg)
		1	2	1+2
Hotspot SAR	Top	0.017	0.177	0.194
	Bottom	-	-	-
	Front	0.035	0.075	0.110
	Rear	0.031	0.527	0.558
	Right	-	-	-
	Left	0.056	0.338	0.394

Note : The above simultaneous result is the worst case result for Bluetooth Ant1 + 5 G WLAN MIMO simultaneous case for Hotspot.

Table 13.5.22 Simultaneous Transmission Scenario for 2G/3G/4G with Bluetooth (Hotspot at 10 mm)

Exposure Condition	Mode	2G/3G/4G SAR (W/kg)	Bluetooth SAR (W/kg)	Σ SAR (W/kg)
		1	2	1+2
Body-Worn SAR	GPRS 850	0.746	0.031	0.777
	GPRS 1900	0.989	0.035	1.024
	WCDMA 850	0.759	0.031	0.790
	WCDMA 1700	0.500	0.035	0.535
	WCDMA 1900	0.956	0.035	0.991
	LTE Band 17	0.458	0.031	0.489
	LTE Band 13	0.271	0.031	0.302
	LTE Band 5	0.729	0.031	0.760

Simul Tx	Configuration	GPRS 1900 SAR (W/kg)	Bluetooth SAR (W/kg)	Σ SAR (W/kg)
		1	2	1+2
Hotspot SAR	Top	-	0.017	0.017
	Bottom	0.987	-	0.987
	Front	0.989	0.035	1.024
	Rear	0.873	0.031	0.904
	Right	-	-	-
	Left	0.486	0.056	0.542

Note : The above simultaneous result is the worst case result for 2G/3G/4G + Bluetooth simultaneous case for Hotspot.

13.7 Phablet SAR Simultaneous Transmission Analysis

Per FCC KDB Publication 648474 D04 Handset SAR, Phablet SAR tests were not required of Hotspot 1g SAR scaled to maximum output power, including tolerance < 1.2 W/kg. Therefore no further analysis was required to for Phablet Simultaneous Transmission Analysis.

13.8 Simultaneous Transmission Conclusion

The above numerical summed SAR results for all the worst-case simultaneous transmission conditions were below the SAR limit. Therefore, the above analysis is sufficient to determine that simultaneous transmission cases will not exceed the SAR limit and therefore no measured volumetric simultaneous SAR summation is required per FCC KDB Publication 447498 D01v06 and IEEE 1528-2013 Section 6.3.4.1.2.

14. SAR MEASUREMENT VARIABILITY

14.1 Measurement Variability

Per FCC KDB Publication 865664 D01v01r04, SAR measurement variability was assessed for each frequency band, which was determined by the SAR probe calibration point and tissue-equivalent medium used for the device measurements. When both head and body tissue-equivalent media were required for SAR measurements in a frequency band, the variability measurement procedures were applied to the tissue medium with the highest measured SAR, using the highest measured SAR configuration for that tissue-equivalent medium. These additional measurements were repeated after the completion of all measurements requiring the same head or body tissue-equivalent medium in a frequency band. The test device was returned to ambient conditions (normal room temperature) with the battery fully charged before it was re-mounted on the device holder for the repeated measurement(s) to minimize any unexpected variations in the repeated results.

SAR Measurement Variability was assessed using the following procedures for each frequency band:

1. When the original highest measured SAR is ≥ 0.80 W/kg, the measurement was repeated once.
2. A second repeated measurement was performed only if the ratio of largest to smallest SAR for the original and first repeated measurements was > 1.20 or when the original or repeated measurement was ≥ 1.45 W/kg (~ 10% from the 1-g SAR limit).
3. A third repeated measurement was performed only if the original, first or second repeated measurement was ≥ 1.5 W/kg and the ratio of largest to smallest SAR for the original, first and second repeated measurements is > 1.20 .
4. Repeated measurements are not required when the original highest measured SAR is < 0.80 W/kg

Table 14.1 Head SAR Measurement Variability Results

Frequency		Mode	Service	# of Time Slots	Spacing [Side]	Measured SAR (1g)	1st Repeated SAR(1g)	Ratio	2nd Repeated SAR(1g)	Ratio	3rd Repeated SAR(1g)	Ratio
MHz	Ch.					(W/kg)	(W/kg)		(W/kg)		(W/kg)	
2412	1	802.11b (MIMO)	DSSS	-	Right Touch	0.827	0.821	1.01	-	-	-	-
5300	60	802.11a (MIMO)	OFDM	-	Right Tilt	0.869	0.856	1.02	-	-	-	-
ANSI / IEEE C95.1-1992– SAFETY LIMIT Spatial Peak Uncontrolled Exposure/General Population Exposure						Head 1.6 W/kg (mW/g) averaged over 1 gram						

Table 14.2 Body-Worn SAR Measurement Variability Results

Frequency		Mode	Service	# of Time Slots	Spacing [Side]	Measured SAR (1g)	1st Repeated SAR(1g)	Ratio	2nd Repeated SAR(1g)	Ratio	3rd Repeated SAR(1g)	Ratio
MHz	Ch.					(W/kg)	(W/kg)		(W/kg)		(W/kg)	
1880.0	661	PCS1900	GPRS	2	10 mm [Front]	0.923	0.910	1.01	-	-	-	-
ANSI / IEEE C95.1-1992– SAFETY LIMIT Spatial Peak Uncontrolled Exposure/General Population Exposure						Body 1.6 W/kg (mW/g) averaged over 1 gram						

Table 14.3 Hotspot SAR Measurement Variability Results

Frequency		Mode	Service	# of Time Slots	Spacing [Side]	Measured SAR (1g)	1st Repeated SAR(1g)	Ratio	2nd Repeated SAR(1g)	Ratio	3rd Repeated SAR(1g)	Ratio
MHz	Ch.					(W/kg)	(W/kg)		(W/kg)		(W/kg)	
1880.0	661	PCS1900	GPRS	2	10 mm [Front]	0.923	0.910	1.01	-	-	-	-
ANSI / IEEE C95.1-1992– SAFETY LIMIT Spatial Peak Uncontrolled Exposure/General Population Exposure							Body 1.6 W/kg (mW/g) averaged over 1 gram					

Table 14.4 Phablet SAR Measurement Variability Results

Frequency		Mode	Service	# of Time Slots	Spacing [Side]	Measured SAR (10g)	1st Repeated SAR(10g)	Ratio	2nd Repeated SAR(10g)	Ratio	3rd Repeated SAR(10g)	Ratio
MHz	Ch.					(W/kg)	(W/kg)		(W/kg)		(W/kg)	
5300	60	802.11a (MIMO)	OFDM	-	0 mm [Rear]	2.040	1.820	1.12	-	-	-	-
5580	116	802.11a (MIMO)	OFDM	-	0 mm [Rear]	2.020	2.010	1.00	-	-	-	-
ANSI / IEEE C95.1-1992– SAFETY LIMIT Spatial Peak Uncontrolled Exposure/General Population Exposure							Hand 4.0 W/kg (mW/g) averaged over 10 gram					

15. IEEE Std 1528 –MEASUREMENT UNCERTAINTIES

750 MHz Head (SN: 3328)

Error Description	Uncertainty value $\pm\%$	Probability Distribution	Divisor	(Ci) 1g	Standard (1g)	vi 2 or Veff
Measurement System						
Probe calibration	± 6.0	Normal	1	1	$\pm 6.0 \%$	∞
Axial isotropy	± 4.7	Rectangular	$\sqrt{3}$	1	$\pm 2.7 \%$	∞
Hemispherical isotropy	± 9.6	Rectangular	$\sqrt{3}$	1	$\pm 5.5 \%$	∞
Boundary Effects	± 0.8	Rectangular	$\sqrt{3}$	1	$\pm 0.46 \%$	∞
Probe Linearity	± 4.7	Rectangular	$\sqrt{3}$	1	$\pm 2.7 \%$	∞
Probe modulation response	± 2.4	Rectangular	$\sqrt{3}$	1	$\pm 1.4 \%$	∞
Detection limits	± 0.25	Rectangular	$\sqrt{3}$	1	$\pm 0.14 \%$	∞
Readout Electronics	± 1.0	Normal	1	1	$\pm 1.0 \%$	∞
Response time	± 0.8	Rectangular	$\sqrt{3}$	1	$\pm 0.46 \%$	∞
Integration time	± 2.6	Rectangular	$\sqrt{3}$	1	$\pm 1.5 \%$	∞
RF Ambient Conditions – Noise	± 3.0	Rectangular	$\sqrt{3}$	1	$\pm 1.7 \%$	∞
RF Ambient Conditions – Reflections	± 3.0	Rectangular	$\sqrt{3}$	1	$\pm 1.7 \%$	∞
Probe Positioner	± 0.4	Rectangular	$\sqrt{3}$	1	$\pm 0.23 \%$	∞
Probe Positioning	± 2.9	Rectangular	$\sqrt{3}$	1	$\pm 1.7 \%$	∞
Algorithms for Max. SAR Eval.	± 1.0	Rectangular	$\sqrt{3}$	1	$\pm 0.58 \%$	∞
Test Sample Related						
Device Positioning	± 2.9	Normal	1	1	$\pm 2.9 \%$	145
Device Holder	± 3.6	Normal	1	1	$\pm 3.6 \%$	5
Power Drift	± 5.0	Rectangular	$\sqrt{3}$	1	$\pm 2.9 \%$	∞
SAR Scaling	± 2.0	Rectangular	$\sqrt{3}$	1	$\pm 1.2 \%$	∞
Physical Parameters						
Phantom Shell	± 4.0	Rectangular	$\sqrt{3}$	1	$\pm 2.3 \%$	∞
Liquid conductivity (Target)	± 5.0	Rectangular	$\sqrt{3}$	0.64	$\pm 2.9 \%$	∞
Liquid conductivity (Meas.)	± 4.5	Normal	1	0.64	$\pm 4.5 \%$	∞
Liquid permittivity (Target)	± 5.0	Rectangular	$\sqrt{3}$	0.6	$\pm 2.9 \%$	∞
Liquid permittivity (Meas.)	± 4.0	Normal	1	0.6	$\pm 4.0 \%$	∞
Temp. unc. - Conductivity	± 1.8	Rectangular	$\sqrt{3}$	0.78	$\pm 1.0 \%$	∞
Temp. unc. - Permittivity	± 1.9	Rectangular	$\sqrt{3}$	0.23	$\pm 1.1 \%$	∞
Combined Standard Uncertainty					$\pm 12 \%$	330
Expanded Uncertainty (k=2)					$\pm 24 \%$	

The above measurement uncertainties are according to IEEE Std 1528

750 MHz Body (SN: 3328)

Error Description	Uncertainty value $\pm\%$	Probability Distribution	Divisor	(Ci) 1g	Standard (1g)	vi 2 or Veff
Measurement System						
Probe calibration	± 6.0	Normal	1	1	$\pm 6.0 \%$	∞
Axial isotropy	± 4.7	Rectangular	$\sqrt{3}$	1	$\pm 2.7 \%$	∞
Hemispherical isotropy	± 9.6	Rectangular	$\sqrt{3}$	1	$\pm 5.5 \%$	∞
Boundary Effects	± 0.8	Rectangular	$\sqrt{3}$	1	$\pm 0.46 \%$	∞
Probe Linearity	± 4.7	Rectangular	$\sqrt{3}$	1	$\pm 2.7 \%$	∞
Probe modulation response	± 2.4	Rectangular	$\sqrt{3}$	1	$\pm 1.4 \%$	∞
Detection limits	± 0.25	Rectangular	$\sqrt{3}$	1	$\pm 0.14 \%$	∞
Readout Electronics	± 1.0	Normal	1	1	$\pm 1.0 \%$	∞
Response time	± 0.8	Rectangular	$\sqrt{3}$	1	$\pm 0.46 \%$	∞
Integration time	± 2.6	Rectangular	$\sqrt{3}$	1	$\pm 1.5 \%$	∞
RF Ambient Conditions – Noise	± 3.0	Rectangular	$\sqrt{3}$	1	$\pm 1.7 \%$	∞
RF Ambient Conditions – Reflections	± 3.0	Rectangular	$\sqrt{3}$	1	$\pm 1.7 \%$	∞
Probe Positioner	± 0.4	Rectangular	$\sqrt{3}$	1	$\pm 0.23 \%$	∞
Probe Positioning	± 2.9	Rectangular	$\sqrt{3}$	1	$\pm 1.7 \%$	∞
Algorithms for Max. SAR Eval.	± 1.0	Rectangular	$\sqrt{3}$	1	$\pm 0.58 \%$	∞
Test Sample Related						
Device Positioning	± 2.9	Normal	1	1	$\pm 2.9 \%$	145
Device Holder	± 3.6	Normal	1	1	$\pm 3.6 \%$	5
Power Drift	± 5.0	Rectangular	$\sqrt{3}$	1	$\pm 2.9 \%$	∞
SAR Scaling	± 2.0	Rectangular	$\sqrt{3}$	1	$\pm 1.2 \%$	∞
Physical Parameters						
Phantom Shell	± 4.0	Rectangular	$\sqrt{3}$	1	$\pm 2.3 \%$	∞
Liquid conductivity (Target)	± 5.0	Rectangular	$\sqrt{3}$	0.64	$\pm 2.9 \%$	∞
Liquid conductivity (Meas.)	± 4.4	Normal	1	0.64	$\pm 4.4 \%$	∞
Liquid permittivity (Target)	± 5.0	Rectangular	$\sqrt{3}$	0.6	$\pm 2.9 \%$	∞
Liquid permittivity (Meas.)	± 4.1	Normal	1	0.6	$\pm 4.1 \%$	∞
Temp. unc. - Conductivity	± 2.0	Rectangular	$\sqrt{3}$	0.78	$\pm 1.2 \%$	∞
Temp. unc. - Permittivity	± 1.8	Rectangular	$\sqrt{3}$	0.23	$\pm 1.0 \%$	∞
Combined Standard Uncertainty					$\pm 12 \%$	330
Expanded Uncertainty (k=2)					$\pm 24 \%$	

The above measurement uncertainties are according to IEEE Std 1528

835 MHz Head (SN: 3328)

Error Description	Uncertainty value $\pm\%$	Probability Distribution	Divisor	(Ci) 1g	Standard (1g)	vi 2 or Veff
Measurement System						
Probe calibration	± 6.0	Normal	1	1	$\pm 6.0 \%$	∞
Axial isotropy	± 4.7	Rectangular	$\sqrt{3}$	1	$\pm 2.7 \%$	∞
Hemispherical isotropy	± 9.6	Rectangular	$\sqrt{3}$	1	$\pm 5.5 \%$	∞
Boundary Effects	± 0.8	Rectangular	$\sqrt{3}$	1	$\pm 0.46 \%$	∞
Probe Linearity	± 4.7	Rectangular	$\sqrt{3}$	1	$\pm 2.7 \%$	∞
Probe modulation response	± 2.4	Rectangular	$\sqrt{3}$	1	$\pm 1.4 \%$	∞
Detection limits	± 0.25	Rectangular	$\sqrt{3}$	1	$\pm 0.14 \%$	∞
Readout Electronics	± 1.0	Normal	1	1	$\pm 1.0 \%$	∞
Response time	± 0.8	Rectangular	$\sqrt{3}$	1	$\pm 0.46 \%$	∞
Integration time	± 2.6	Rectangular	$\sqrt{3}$	1	$\pm 1.5 \%$	∞
RF Ambient Conditions – Noise	± 3.0	Rectangular	$\sqrt{3}$	1	$\pm 1.7 \%$	∞
RF Ambient Conditions – Reflections	± 3.0	Rectangular	$\sqrt{3}$	1	$\pm 1.7 \%$	∞
Probe Positioner	± 0.4	Rectangular	$\sqrt{3}$	1	$\pm 0.23 \%$	∞
Probe Positioning	± 2.9	Rectangular	$\sqrt{3}$	1	$\pm 1.7 \%$	∞
Algorithms for Max. SAR Eval.	± 1.0	Rectangular	$\sqrt{3}$	1	$\pm 0.58 \%$	∞
Test Sample Related						
Device Positioning	± 2.9	Normal	1	1	$\pm 2.9 \%$	145
Device Holder	± 3.6	Normal	1	1	$\pm 3.6 \%$	5
Power Drift	± 5.0	Rectangular	$\sqrt{3}$	1	$\pm 2.9 \%$	∞
SAR Scaling	± 2.0	Rectangular	$\sqrt{3}$	1	$\pm 1.2 \%$	∞
Physical Parameters						
Phantom Shell	± 4.0	Rectangular	$\sqrt{3}$	1	$\pm 2.3 \%$	∞
Liquid conductivity (Target)	± 5.0	Rectangular	$\sqrt{3}$	0.64	$\pm 2.9 \%$	∞
Liquid conductivity (Meas.)	± 4.0	Normal	1	0.64	$\pm 4.0 \%$	∞
Liquid permittivity (Target)	± 5.0	Rectangular	$\sqrt{3}$	0.6	$\pm 2.9 \%$	∞
Liquid permittivity (Meas.)	± 3.8	Normal	1	0.6	$\pm 3.8 \%$	∞
Temp. unc. - Conductivity	± 1.7	Rectangular	$\sqrt{3}$	0.78	$\pm 1.0 \%$	∞
Temp. unc. - Permittivity	± 1.8	Rectangular	$\sqrt{3}$	0.23	$\pm 1.0 \%$	∞
Combined Standard Uncertainty					$\pm 12 \%$	330
Expanded Uncertainty (k=2)					$\pm 24 \%$	

The above measurement uncertainties are according to IEEE Std 1528

835 MHz Body (SN: 3328)

Error Description	Uncertainty value $\pm\%$	Probability Distribution	Divisor	(Ci) 1g	Standard (1g)	vi 2 or Veff
Measurement System						
Probe calibration	± 6.0	Normal	1	1	$\pm 6.0 \%$	∞
Axial isotropy	± 4.7	Rectangular	$\sqrt{3}$	1	$\pm 2.7 \%$	∞
Hemispherical isotropy	± 9.6	Rectangular	$\sqrt{3}$	1	$\pm 5.5 \%$	∞
Boundary Effects	± 0.8	Rectangular	$\sqrt{3}$	1	$\pm 0.46 \%$	∞
Probe Linearity	± 4.7	Rectangular	$\sqrt{3}$	1	$\pm 2.7 \%$	∞
Probe modulation response	± 2.4	Rectangular	$\sqrt{3}$	1	$\pm 1.4 \%$	∞
Detection limits	± 0.25	Rectangular	$\sqrt{3}$	1	$\pm 0.14 \%$	∞
Readout Electronics	± 1.0	Normal	1	1	$\pm 1.0 \%$	∞
Response time	± 0.8	Rectangular	$\sqrt{3}$	1	$\pm 0.46 \%$	∞
Integration time	± 2.6	Rectangular	$\sqrt{3}$	1	$\pm 1.5 \%$	∞
RF Ambient Conditions – Noise	± 3.0	Rectangular	$\sqrt{3}$	1	$\pm 1.7 \%$	∞
RF Ambient Conditions – Reflections	± 3.0	Rectangular	$\sqrt{3}$	1	$\pm 1.7 \%$	∞
Probe Positioner	± 0.4	Rectangular	$\sqrt{3}$	1	$\pm 0.23 \%$	∞
Probe Positioning	± 2.9	Rectangular	$\sqrt{3}$	1	$\pm 1.7 \%$	∞
Algorithms for Max. SAR Eval.	± 1.0	Rectangular	$\sqrt{3}$	1	$\pm 0.58 \%$	∞
Test Sample Related						
Device Positioning	± 2.9	Normal	1	1	$\pm 2.9 \%$	145
Device Holder	± 3.6	Normal	1	1	$\pm 3.6 \%$	5
Power Drift	± 5.0	Rectangular	$\sqrt{3}$	1	$\pm 2.9 \%$	∞
SAR Scaling	± 2.0	Rectangular	$\sqrt{3}$	1	$\pm 1.2 \%$	∞
Physical Parameters						
Phantom Shell	± 4.0	Rectangular	$\sqrt{3}$	1	$\pm 2.3 \%$	∞
Liquid conductivity (Target)	± 5.0	Rectangular	$\sqrt{3}$	0.64	$\pm 2.9 \%$	∞
Liquid conductivity (Meas.)	± 4.3	Normal	1	0.64	$\pm 4.3 \%$	∞
Liquid permittivity (Target)	± 5.0	Rectangular	$\sqrt{3}$	0.6	$\pm 2.9 \%$	∞
Liquid permittivity (Meas.)	± 3.7	Normal	1	0.6	$\pm 3.7 \%$	∞
Temp. unc. - Conductivity	± 1.7	Rectangular	$\sqrt{3}$	0.78	$\pm 1.0 \%$	∞
Temp. unc. - Permittivity	± 1.9	Rectangular	$\sqrt{3}$	0.23	$\pm 1.1 \%$	∞
Combined Standard Uncertainty					$\pm 12 \%$	330
Expanded Uncertainty (k=2)					$\pm 24 \%$	

The above measurement uncertainties are according to IEEE Std 1528

1800 MHz Head (SN: 3328)

Error Description	Uncertainty value $\pm\%$	Probability Distribution	Divisor	(Ci) 1g	Standard (1g)	vi 2 or Veff
Measurement System						
Probe calibration	± 6.0	Normal	1	1	$\pm 6.0 \%$	∞
Axial isotropy	± 4.7	Rectangular	$\sqrt{3}$	1	$\pm 2.7 \%$	∞
Hemispherical isotropy	± 9.6	Rectangular	$\sqrt{3}$	1	$\pm 5.5 \%$	∞
Boundary Effects	± 0.8	Rectangular	$\sqrt{3}$	1	$\pm 0.46 \%$	∞
Probe Linearity	± 4.7	Rectangular	$\sqrt{3}$	1	$\pm 2.7 \%$	∞
Probe modulation response	± 2.4	Rectangular	$\sqrt{3}$	1	$\pm 1.4 \%$	∞
Detection limits	± 0.25	Rectangular	$\sqrt{3}$	1	$\pm 0.14 \%$	∞
Readout Electronics	± 1.0	Normal	1	1	$\pm 1.0 \%$	∞
Response time	± 0.8	Rectangular	$\sqrt{3}$	1	$\pm 0.46 \%$	∞
Integration time	± 2.6	Rectangular	$\sqrt{3}$	1	$\pm 1.5 \%$	∞
RF Ambient Conditions – Noise	± 3.0	Rectangular	$\sqrt{3}$	1	$\pm 1.7 \%$	∞
RF Ambient Conditions – Reflections	± 3.0	Rectangular	$\sqrt{3}$	1	$\pm 1.7 \%$	∞
Probe Positioner	± 0.4	Rectangular	$\sqrt{3}$	1	$\pm 0.23 \%$	∞
Probe Positioning	± 2.9	Rectangular	$\sqrt{3}$	1	$\pm 1.7 \%$	∞
Algorithms for Max. SAR Eval.	± 1.0	Rectangular	$\sqrt{3}$	1	$\pm 0.58 \%$	∞
Test Sample Related						
Device Positioning	± 2.9	Normal	1	1	$\pm 2.9 \%$	145
Device Holder	± 3.6	Normal	1	1	$\pm 3.6 \%$	5
Power Drift	± 5.0	Rectangular	$\sqrt{3}$	1	$\pm 2.9 \%$	∞
SAR Scaling	± 2.0	Rectangular	$\sqrt{3}$	1	$\pm 1.2 \%$	∞
Physical Parameters						
Phantom Shell	± 4.0	Rectangular	$\sqrt{3}$	1	$\pm 2.3 \%$	∞
Liquid conductivity (Target)	± 5.0	Rectangular	$\sqrt{3}$	0.64	$\pm 2.9 \%$	∞
Liquid conductivity (Meas.)	± 4.4	Normal	1	0.64	$\pm 4.4 \%$	∞
Liquid permittivity (Target)	± 5.0	Rectangular	$\sqrt{3}$	0.6	$\pm 2.9 \%$	∞
Liquid permittivity (Meas.)	± 4.0	Normal	1	0.6	$\pm 4.0 \%$	∞
Temp. unc. - Conductivity	± 2.0	Rectangular	$\sqrt{3}$	0.78	$\pm 1.2 \%$	∞
Temp. unc. - Permittivity	± 1.9	Rectangular	$\sqrt{3}$	0.23	$\pm 1.1 \%$	∞
Combined Standard Uncertainty					$\pm 12 \%$	330
Expanded Uncertainty (k=2)					$\pm 24 \%$	

The above measurement uncertainties are according to IEEE Std 1528

1800 MHz Body (SN: 3328)

Error Description	Uncertainty value $\pm\%$	Probability Distribution	Divisor	(Ci) 1g	Standard (1g)	vi 2 or Veff
Measurement System						
Probe calibration	± 6.0	Normal	1	1	$\pm 6.0 \%$	∞
Axial isotropy	± 4.7	Rectangular	$\sqrt{3}$	1	$\pm 2.7 \%$	∞
Hemispherical isotropy	± 9.6	Rectangular	$\sqrt{3}$	1	$\pm 5.5 \%$	∞
Boundary Effects	± 0.8	Rectangular	$\sqrt{3}$	1	$\pm 0.46 \%$	∞
Probe Linearity	± 4.7	Rectangular	$\sqrt{3}$	1	$\pm 2.7 \%$	∞
Probe modulation response	± 2.4	Rectangular	$\sqrt{3}$	1	$\pm 1.4 \%$	∞
Detection limits	± 0.25	Rectangular	$\sqrt{3}$	1	$\pm 0.14 \%$	∞
Readout Electronics	± 1.0	Normal	1	1	$\pm 1.0 \%$	∞
Response time	± 0.8	Rectangular	$\sqrt{3}$	1	$\pm 0.46 \%$	∞
Integration time	± 2.6	Rectangular	$\sqrt{3}$	1	$\pm 1.5 \%$	∞
RF Ambient Conditions – Noise	± 3.0	Rectangular	$\sqrt{3}$	1	$\pm 1.7 \%$	∞
RF Ambient Conditions – Reflections	± 3.0	Rectangular	$\sqrt{3}$	1	$\pm 1.7 \%$	∞
Probe Positioner	± 0.4	Rectangular	$\sqrt{3}$	1	$\pm 0.23 \%$	∞
Probe Positioning	± 2.9	Rectangular	$\sqrt{3}$	1	$\pm 1.7 \%$	∞
Algorithms for Max. SAR Eval.	± 1.0	Rectangular	$\sqrt{3}$	1	$\pm 0.58 \%$	∞
Test Sample Related						
Device Positioning	± 2.9	Normal	1	1	$\pm 2.9 \%$	145
Device Holder	± 3.6	Normal	1	1	$\pm 3.6 \%$	5
Power Drift	± 5.0	Rectangular	$\sqrt{3}$	1	$\pm 2.9 \%$	∞
SAR Scaling	± 2.0	Rectangular	$\sqrt{3}$	1	$\pm 1.2 \%$	∞
Physical Parameters						
Phantom Shell	± 4.0	Rectangular	$\sqrt{3}$	1	$\pm 2.3 \%$	∞
Liquid conductivity (Target)	± 5.0	Rectangular	$\sqrt{3}$	0.64	$\pm 2.9 \%$	∞
Liquid conductivity (Meas.)	± 4.3	Normal	1	0.64	$\pm 4.3 \%$	∞
Liquid permittivity (Target)	± 5.0	Rectangular	$\sqrt{3}$	0.6	$\pm 2.9 \%$	∞
Liquid permittivity (Meas.)	± 4.2	Normal	1	0.6	$\pm 4.2 \%$	∞
Temp. unc. - Conductivity	± 1.8	Rectangular	$\sqrt{3}$	0.78	$\pm 1.0 \%$	∞
Temp. unc. - Permittivity	± 1.8	Rectangular	$\sqrt{3}$	0.23	$\pm 1.0 \%$	∞
Combined Standard Uncertainty					$\pm 12 \%$	330
Expanded Uncertainty (k=2)					$\pm 24 \%$	

The above measurement uncertainties are according to IEEE Std 1528

1900 MHz Head (SN: 3328)

Error Description	Uncertainty value $\pm\%$	Probability Distribution	Divisor	(Ci) 1g	Standard (1g)	vi 2 or Veff
Measurement System						
Probe calibration	± 6.0	Normal	1	1	$\pm 6.0 \%$	∞
Axial isotropy	± 4.7	Rectangular	$\sqrt{3}$	1	$\pm 2.7 \%$	∞
Hemispherical isotropy	± 9.6	Rectangular	$\sqrt{3}$	1	$\pm 5.5 \%$	∞
Boundary Effects	± 0.8	Rectangular	$\sqrt{3}$	1	$\pm 0.46 \%$	∞
Probe Linearity	± 4.7	Rectangular	$\sqrt{3}$	1	$\pm 2.7 \%$	∞
Probe modulation response	± 2.4	Rectangular	$\sqrt{3}$	1	$\pm 1.4 \%$	∞
Detection limits	± 0.25	Rectangular	$\sqrt{3}$	1	$\pm 0.14 \%$	∞
Readout Electronics	± 1.0	Normal	1	1	$\pm 1.0 \%$	∞
Response time	± 0.8	Rectangular	$\sqrt{3}$	1	$\pm 0.46 \%$	∞
Integration time	± 2.6	Rectangular	$\sqrt{3}$	1	$\pm 1.5 \%$	∞
RF Ambient Conditions – Noise	± 3.0	Rectangular	$\sqrt{3}$	1	$\pm 1.7 \%$	∞
RF Ambient Conditions – Reflections	± 3.0	Rectangular	$\sqrt{3}$	1	$\pm 1.7 \%$	∞
Probe Positioner	± 0.4	Rectangular	$\sqrt{3}$	1	$\pm 0.23 \%$	∞
Probe Positioning	± 2.9	Rectangular	$\sqrt{3}$	1	$\pm 1.7 \%$	∞
Algorithms for Max. SAR Eval.	± 1.0	Rectangular	$\sqrt{3}$	1	$\pm 0.58 \%$	∞
Test Sample Related						
Device Positioning	± 2.9	Normal	1	1	$\pm 2.9 \%$	145
Device Holder	± 3.6	Normal	1	1	$\pm 3.6 \%$	5
Power Drift	± 5.0	Rectangular	$\sqrt{3}$	1	$\pm 2.9 \%$	∞
SAR Scaling	± 2.0	Rectangular	$\sqrt{3}$	1	$\pm 1.2 \%$	∞
Physical Parameters						
Phantom Shell	± 4.0	Rectangular	$\sqrt{3}$	1	$\pm 2.3 \%$	∞
Liquid conductivity (Target)	± 5.0	Rectangular	$\sqrt{3}$	0.64	$\pm 2.9 \%$	∞
Liquid conductivity (Meas.)	± 3.9	Normal	1	0.64	$\pm 3.9 \%$	∞
Liquid permittivity (Target)	± 5.0	Rectangular	$\sqrt{3}$	0.6	$\pm 2.9 \%$	∞
Liquid permittivity (Meas.)	± 4.2	Normal	1	0.6	$\pm 4.2 \%$	∞
Temp. unc. - Conductivity	± 1.7	Rectangular	$\sqrt{3}$	0.78	$\pm 1.0 \%$	∞
Temp. unc. - Permittivity	± 1.9	Rectangular	$\sqrt{3}$	0.23	$\pm 1.1 \%$	∞
Combined Standard Uncertainty					$\pm 12 \%$	330
Expanded Uncertainty (k=2)					$\pm 24 \%$	

The above measurement uncertainties are according to IEEE Std 1528

1900 MHz Body (SN: 3328)

Error Description	Uncertainty value $\pm\%$	Probability Distribution	Divisor	(Ci) 1g	Standard (1g)	vi 2 or Veff
Measurement System						
Probe calibration	± 6.0	Normal	1	1	$\pm 6.0 \%$	∞
Axial isotropy	± 4.7	Rectangular	$\sqrt{3}$	1	$\pm 2.7 \%$	∞
Hemispherical isotropy	± 9.6	Rectangular	$\sqrt{3}$	1	$\pm 5.5 \%$	∞
Boundary Effects	± 0.8	Rectangular	$\sqrt{3}$	1	$\pm 0.46 \%$	∞
Probe Linearity	± 4.7	Rectangular	$\sqrt{3}$	1	$\pm 2.7 \%$	∞
Probe modulation response	± 2.4	Rectangular	$\sqrt{3}$	1	$\pm 1.4 \%$	∞
Detection limits	± 0.25	Rectangular	$\sqrt{3}$	1	$\pm 0.14 \%$	∞
Readout Electronics	± 1.0	Normal	1	1	$\pm 1.0 \%$	∞
Response time	± 0.8	Rectangular	$\sqrt{3}$	1	$\pm 0.46 \%$	∞
Integration time	± 2.6	Rectangular	$\sqrt{3}$	1	$\pm 1.5 \%$	∞
RF Ambient Conditions – Noise	± 3.0	Rectangular	$\sqrt{3}$	1	$\pm 1.7 \%$	∞
RF Ambient Conditions – Reflections	± 3.0	Rectangular	$\sqrt{3}$	1	$\pm 1.7 \%$	∞
Probe Positioner	± 0.4	Rectangular	$\sqrt{3}$	1	$\pm 0.23 \%$	∞
Probe Positioning	± 2.9	Rectangular	$\sqrt{3}$	1	$\pm 1.7 \%$	∞
Algorithms for Max. SAR Eval.	± 1.0	Rectangular	$\sqrt{3}$	1	$\pm 0.58 \%$	∞
Test Sample Related						
Device Positioning	± 2.9	Normal	1	1	$\pm 2.9 \%$	145
Device Holder	± 3.6	Normal	1	1	$\pm 3.6 \%$	5
Power Drift	± 5.0	Rectangular	$\sqrt{3}$	1	$\pm 2.9 \%$	∞
SAR Scaling	± 2.0	Rectangular	$\sqrt{3}$	1	$\pm 1.2 \%$	∞
Physical Parameters						
Phantom Shell	± 4.0	Rectangular	$\sqrt{3}$	1	$\pm 2.3 \%$	∞
Liquid conductivity (Target)	± 5.0	Rectangular	$\sqrt{3}$	0.64	$\pm 2.9 \%$	∞
Liquid conductivity (Meas.)	± 4.1	Normal	1	0.64	$\pm 4.1 \%$	∞
Liquid permittivity (Target)	± 5.0	Rectangular	$\sqrt{3}$	0.6	$\pm 2.9 \%$	∞
Liquid permittivity (Meas.)	± 3.9	Normal	1	0.6	$\pm 3.9 \%$	∞
Temp. unc. - Conductivity	± 1.9	Rectangular	$\sqrt{3}$	0.78	$\pm 1.1 \%$	∞
Temp. unc. - Permittivity	± 1.8	Rectangular	$\sqrt{3}$	0.23	$\pm 1.0 \%$	∞
Combined Standard Uncertainty					$\pm 12 \%$	330
Expanded Uncertainty (k=2)					$\pm 24 \%$	

The above measurement uncertainties are according to IEEE Std 1528

2450 MHz Head (SN: 3930)

Error Description	Uncertainty value $\pm\%$	Probability Distribution	Divisor	(Ci) 1g	Standard (1g)	vi 2 or Veff
Measurement System						
Probe calibration	± 6.0	Normal	1	1	$\pm 6.0 \%$	∞
Axial isotropy	± 4.7	Rectangular	$\sqrt{3}$	1	$\pm 2.7 \%$	∞
Hemispherical isotropy	± 9.6	Rectangular	$\sqrt{3}$	1	$\pm 5.5 \%$	∞
Boundary Effects	± 0.8	Rectangular	$\sqrt{3}$	1	$\pm 0.46 \%$	∞
Probe Linearity	± 4.7	Rectangular	$\sqrt{3}$	1	$\pm 2.7 \%$	∞
Probe modulation response	± 2.4	Rectangular	$\sqrt{3}$	1	$\pm 1.4 \%$	∞
Detection limits	± 0.25	Rectangular	$\sqrt{3}$	1	$\pm 0.14 \%$	∞
Readout Electronics	± 1.0	Normal	1	1	$\pm 1.0 \%$	∞
Response time	± 0.8	Rectangular	$\sqrt{3}$	1	$\pm 0.46 \%$	∞
Integration time	± 2.6	Rectangular	$\sqrt{3}$	1	$\pm 1.5 \%$	∞
RF Ambient Conditions – Noise	± 3.0	Rectangular	$\sqrt{3}$	1	$\pm 1.7 \%$	∞
RF Ambient Conditions – Reflections	± 3.0	Rectangular	$\sqrt{3}$	1	$\pm 1.7 \%$	∞
Probe Positioner	± 0.4	Rectangular	$\sqrt{3}$	1	$\pm 0.23 \%$	∞
Probe Positioning	± 2.9	Rectangular	$\sqrt{3}$	1	$\pm 1.7 \%$	∞
Algorithms for Max. SAR Eval.	± 1.0	Rectangular	$\sqrt{3}$	1	$\pm 0.58 \%$	∞
Test Sample Related						
Device Positioning	± 2.9	Normal	1	1	$\pm 2.9 \%$	145
Device Holder	± 3.6	Normal	1	1	$\pm 3.6 \%$	5
Power Drift	± 5.0	Rectangular	$\sqrt{3}$	1	$\pm 2.9 \%$	∞
SAR Scaling	± 2.0	Rectangular	$\sqrt{3}$	1	$\pm 1.2 \%$	∞
Physical Parameters						
Phantom Shell	± 4.0	Rectangular	$\sqrt{3}$	1	$\pm 2.3 \%$	∞
Liquid conductivity (Target)	± 5.0	Rectangular	$\sqrt{3}$	0.64	$\pm 2.9 \%$	∞
Liquid conductivity (Meas.)	± 4.0	Normal	1	0.64	$\pm 4.0 \%$	∞
Liquid permittivity (Target)	± 5.0	Rectangular	$\sqrt{3}$	0.6	$\pm 2.9 \%$	∞
Liquid permittivity (Meas.)	± 3.9	Normal	1	0.6	$\pm 3.9 \%$	∞
Temp. unc. - Conductivity	± 1.9	Rectangular	$\sqrt{3}$	0.78	$\pm 1.1 \%$	∞
Temp. unc. - Permittivity	± 1.9	Rectangular	$\sqrt{3}$	0.23	$\pm 1.1 \%$	∞
Combined Standard Uncertainty					$\pm 12 \%$	330
Expanded Uncertainty (k=2)					$\pm 24 \%$	

The above measurement uncertainties are according to IEEE Std 1528

2450 MHz Body (SN: 3930)

Error Description	Uncertainty value $\pm\%$	Probability Distribution	Divisor	(Ci) 1g	Standard (1g)	vi 2 or Veff
Measurement System						
Probe calibration	± 6.0	Normal	1	1	$\pm 6.0 \%$	∞
Axial isotropy	± 4.7	Rectangular	$\sqrt{3}$	1	$\pm 2.7 \%$	∞
Hemispherical isotropy	± 9.6	Rectangular	$\sqrt{3}$	1	$\pm 5.5 \%$	∞
Boundary Effects	± 0.8	Rectangular	$\sqrt{3}$	1	$\pm 0.46 \%$	∞
Probe Linearity	± 4.7	Rectangular	$\sqrt{3}$	1	$\pm 2.7 \%$	∞
Probe modulation response	± 2.4	Rectangular	$\sqrt{3}$	1	$\pm 1.4 \%$	∞
Detection limits	± 0.25	Rectangular	$\sqrt{3}$	1	$\pm 0.14 \%$	∞
Readout Electronics	± 1.0	Normal	1	1	$\pm 1.0 \%$	∞
Response time	± 0.8	Rectangular	$\sqrt{3}$	1	$\pm 0.46 \%$	∞
Integration time	± 2.6	Rectangular	$\sqrt{3}$	1	$\pm 1.5 \%$	∞
RF Ambient Conditions – Noise	± 3.0	Rectangular	$\sqrt{3}$	1	$\pm 1.7 \%$	∞
RF Ambient Conditions – Reflections	± 3.0	Rectangular	$\sqrt{3}$	1	$\pm 1.7 \%$	∞
Probe Positioner	± 0.4	Rectangular	$\sqrt{3}$	1	$\pm 0.23 \%$	∞
Probe Positioning	± 2.9	Rectangular	$\sqrt{3}$	1	$\pm 1.7 \%$	∞
Algorithms for Max. SAR Eval.	± 1.0	Rectangular	$\sqrt{3}$	1	$\pm 0.58 \%$	∞
Test Sample Related						
Device Positioning	± 2.9	Normal	1	1	$\pm 2.9 \%$	145
Device Holder	± 3.6	Normal	1	1	$\pm 3.6 \%$	5
Power Drift	± 5.0	Rectangular	$\sqrt{3}$	1	$\pm 2.9 \%$	∞
SAR Scaling	± 2.0	Rectangular	$\sqrt{3}$	1	$\pm 1.2 \%$	∞
Physical Parameters						
Phantom Shell	± 4.0	Rectangular	$\sqrt{3}$	1	$\pm 2.3 \%$	∞
Liquid conductivity (Target)	± 5.0	Rectangular	$\sqrt{3}$	0.64	$\pm 2.9 \%$	∞
Liquid conductivity (Meas.)	± 4.0	Normal	1	0.64	$\pm 4.0 \%$	∞
Liquid permittivity (Target)	± 5.0	Rectangular	$\sqrt{3}$	0.6	$\pm 2.9 \%$	∞
Liquid permittivity (Meas.)	± 3.8	Normal	1	0.6	$\pm 3.8 \%$	∞
Temp. unc. - Conductivity	± 1.9	Rectangular	$\sqrt{3}$	0.78	$\pm 1.1 \%$	∞
Temp. unc. - Permittivity	± 2.0	Rectangular	$\sqrt{3}$	0.23	$\pm 1.2 \%$	∞
Combined Standard Uncertainty					$\pm 12 \%$	330
Expanded Uncertainty (k=2)					$\pm 24 \%$	

The above measurement uncertainties are according to IEEE Std 1528

5200 MHz Head (SN: 3930)

Error Description	Uncertainty value $\pm\%$	Probability Distribution	Divisor	(Ci) 1g	Standard (1g)	vi 2 or Veff
Measurement System						
Probe calibration	± 6.55	Normal	1	1	$\pm 6.6 \%$	∞
Axial isotropy	± 4.7	Rectangular	$\sqrt{3}$	1	$\pm 2.7 \%$	∞
Hemispherical isotropy	± 9.6	Rectangular	$\sqrt{3}$	1	$\pm 5.5 \%$	∞
Boundary Effects	± 0.8	Rectangular	$\sqrt{3}$	1	$\pm 0.46 \%$	∞
Probe Linearity	± 4.7	Rectangular	$\sqrt{3}$	1	$\pm 2.7 \%$	∞
Probe modulation response	± 2.4	Rectangular	$\sqrt{3}$	1	$\pm 1.4 \%$	∞
Detection limits	± 0.25	Rectangular	$\sqrt{3}$	1	$\pm 0.14 \%$	∞
Readout Electronics	± 1.0	Normal	1	1	$\pm 1.0 \%$	∞
Response time	± 0.8	Rectangular	$\sqrt{3}$	1	$\pm 0.46 \%$	∞
Integration time	± 2.6	Rectangular	$\sqrt{3}$	1	$\pm 1.5 \%$	∞
RF Ambient Conditions – Noise	± 3.0	Rectangular	$\sqrt{3}$	1	$\pm 1.7 \%$	∞
RF Ambient Conditions – Reflections	± 3.0	Rectangular	$\sqrt{3}$	1	$\pm 1.7 \%$	∞
Probe Positioner	± 0.4	Rectangular	$\sqrt{3}$	1	$\pm 0.23 \%$	∞
Probe Positioning	± 2.9	Rectangular	$\sqrt{3}$	1	$\pm 1.7 \%$	∞
Algorithms for Max. SAR Eval.	± 1.0	Rectangular	$\sqrt{3}$	1	$\pm 0.58 \%$	∞
Test Sample Related						
Device Positioning	± 2.9	Normal	1	1	$\pm 2.9 \%$	145
Device Holder	± 3.6	Normal	1	1	$\pm 3.6 \%$	5
Power Drift	± 5.0	Rectangular	$\sqrt{3}$	1	$\pm 2.9 \%$	∞
SAR Scaling	± 2.0	Rectangular	$\sqrt{3}$	1	$\pm 1.2 \%$	∞
Physical Parameters						
Phantom Shell	± 4.0	Rectangular	$\sqrt{3}$	1	$\pm 2.3 \%$	∞
Liquid conductivity (Target)	± 5.0	Rectangular	$\sqrt{3}$	0.64	$\pm 2.9 \%$	∞
Liquid conductivity (Meas.)	± 4.1	Normal	1	0.64	$\pm 4.1 \%$	∞
Liquid permittivity (Target)	± 5.0	Rectangular	$\sqrt{3}$	0.6	$\pm 2.9 \%$	∞
Liquid permittivity (Meas.)	± 3.9	Normal	1	0.6	$\pm 3.9 \%$	∞
Temp. unc. - Conductivity	± 1.9	Rectangular	$\sqrt{3}$	0.78	$\pm 1.1 \%$	∞
Temp. unc. - Permittivity	± 1.9	Rectangular	$\sqrt{3}$	0.23	$\pm 1.1 \%$	∞
Combined Standard Uncertainty					$\pm 13 \%$	330
Expanded Uncertainty (k=2)					$\pm 26 \%$	

The above measurement uncertainties are according to IEEE Std 1528

5200 MHz Body (SN: 3930)

Error Description	Uncertainty value $\pm\%$	Probability Distribution	Divisor	(Ci) 1g	Standard (1g)	vi 2 or Veff
Measurement System						
Probe calibration	± 6.55	Normal	1	1	$\pm 6.6 \%$	∞
Axial isotropy	± 4.7	Rectangular	$\sqrt{3}$	1	$\pm 2.7 \%$	∞
Hemispherical isotropy	± 9.6	Rectangular	$\sqrt{3}$	1	$\pm 5.5 \%$	∞
Boundary Effects	± 0.8	Rectangular	$\sqrt{3}$	1	$\pm 0.46 \%$	∞
Probe Linearity	± 4.7	Rectangular	$\sqrt{3}$	1	$\pm 2.7 \%$	∞
Probe modulation response	± 2.4	Rectangular	$\sqrt{3}$	1	$\pm 1.4 \%$	∞
Detection limits	± 0.25	Rectangular	$\sqrt{3}$	1	$\pm 0.14 \%$	∞
Readout Electronics	± 1.0	Normal	1	1	$\pm 1.0 \%$	∞
Response time	± 0.8	Rectangular	$\sqrt{3}$	1	$\pm 0.46 \%$	∞
Integration time	± 2.6	Rectangular	$\sqrt{3}$	1	$\pm 1.5 \%$	∞
RF Ambient Conditions – Noise	± 3.0	Rectangular	$\sqrt{3}$	1	$\pm 1.7 \%$	∞
RF Ambient Conditions – Reflections	± 3.0	Rectangular	$\sqrt{3}$	1	$\pm 1.7 \%$	∞
Probe Positioner	± 0.4	Rectangular	$\sqrt{3}$	1	$\pm 0.23 \%$	∞
Probe Positioning	± 2.9	Rectangular	$\sqrt{3}$	1	$\pm 1.7 \%$	∞
Algorithms for Max. SAR Eval.	± 1.0	Rectangular	$\sqrt{3}$	1	$\pm 0.58 \%$	∞
Test Sample Related						
Device Positioning	± 2.9	Normal	1	1	$\pm 2.9 \%$	145
Device Holder	± 3.6	Normal	1	1	$\pm 3.6 \%$	5
Power Drift	± 5.0	Rectangular	$\sqrt{3}$	1	$\pm 2.9 \%$	∞
SAR Scaling	± 2.0	Rectangular	$\sqrt{3}$	1	$\pm 1.2 \%$	∞
Physical Parameters						
Phantom Shell	± 4.0	Rectangular	$\sqrt{3}$	1	$\pm 2.3 \%$	∞
Liquid conductivity (Target)	± 5.0	Rectangular	$\sqrt{3}$	0.64	$\pm 2.9 \%$	∞
Liquid conductivity (Meas.)	± 4.0	Normal	1	0.64	$\pm 4.0 \%$	∞
Liquid permittivity (Target)	± 5.0	Rectangular	$\sqrt{3}$	0.6	$\pm 2.9 \%$	∞
Liquid permittivity (Meas.)	± 3.8	Normal	1	0.6	$\pm 3.8 \%$	∞
Temp. unc. - Conductivity	± 1.8	Rectangular	$\sqrt{3}$	0.78	$\pm 1.0 \%$	∞
Temp. unc. - Permittivity	± 1.7	Rectangular	$\sqrt{3}$	0.23	$\pm 1.0 \%$	∞
Combined Standard Uncertainty					$\pm 13 \%$	330
Expanded Uncertainty (k=2)					$\pm 26 \%$	

The above measurement uncertainties are according to IEEE Std 1528

5300 MHz Head (SN: 3930)

Error Description	Uncertainty value $\pm\%$	Probability Distribution	Divisor	(Ci) 1g	Standard (1g)	vi 2 or Veff
Measurement System						
Probe calibration	± 6.55	Normal	1	1	$\pm 6.6 \%$	∞
Axial isotropy	± 4.7	Rectangular	$\sqrt{3}$	1	$\pm 2.7 \%$	∞
Hemispherical isotropy	± 9.6	Rectangular	$\sqrt{3}$	1	$\pm 5.5 \%$	∞
Boundary Effects	± 0.8	Rectangular	$\sqrt{3}$	1	$\pm 0.46 \%$	∞
Probe Linearity	± 4.7	Rectangular	$\sqrt{3}$	1	$\pm 2.7 \%$	∞
Probe modulation response	± 2.4	Rectangular	$\sqrt{3}$	1	$\pm 1.4 \%$	∞
Detection limits	± 0.25	Rectangular	$\sqrt{3}$	1	$\pm 0.14 \%$	∞
Readout Electronics	± 1.0	Normal	1	1	$\pm 1.0 \%$	∞
Response time	± 0.8	Rectangular	$\sqrt{3}$	1	$\pm 0.46 \%$	∞
Integration time	± 2.6	Rectangular	$\sqrt{3}$	1	$\pm 1.5 \%$	∞
RF Ambient Conditions – Noise	± 3.0	Rectangular	$\sqrt{3}$	1	$\pm 1.7 \%$	∞
RF Ambient Conditions – Reflections	± 3.0	Rectangular	$\sqrt{3}$	1	$\pm 1.7 \%$	∞
Probe Positioner	± 0.4	Rectangular	$\sqrt{3}$	1	$\pm 0.23 \%$	∞
Probe Positioning	± 2.9	Rectangular	$\sqrt{3}$	1	$\pm 1.7 \%$	∞
Algorithms for Max. SAR Eval.	± 1.0	Rectangular	$\sqrt{3}$	1	$\pm 0.58 \%$	∞
Test Sample Related						
Device Positioning	± 2.9	Normal	1	1	$\pm 2.9 \%$	145
Device Holder	± 3.6	Normal	1	1	$\pm 3.6 \%$	5
Power Drift	± 5.0	Rectangular	$\sqrt{3}$	1	$\pm 2.9 \%$	∞
SAR Scaling	± 2.0	Rectangular	$\sqrt{3}$	1	$\pm 1.2 \%$	∞
Physical Parameters						
Phantom Shell	± 4.0	Rectangular	$\sqrt{3}$	1	$\pm 2.3 \%$	∞
Liquid conductivity (Target)	± 5.0	Rectangular	$\sqrt{3}$	0.64	$\pm 2.9 \%$	∞
Liquid conductivity (Meas.)	± 3.7	Normal	1	0.64	$\pm 3.7 \%$	∞
Liquid permittivity (Target)	± 5.0	Rectangular	$\sqrt{3}$	0.6	$\pm 2.9 \%$	∞
Liquid permittivity (Meas.)	± 4.0	Normal	1	0.6	$\pm 4.0 \%$	∞
Temp. unc. - Conductivity	± 1.7	Rectangular	$\sqrt{3}$	0.78	$\pm 1.0 \%$	∞
Temp. unc. - Permittivity	± 1.8	Rectangular	$\sqrt{3}$	0.23	$\pm 1.0 \%$	∞
Combined Standard Uncertainty					$\pm 13 \%$	330
Expanded Uncertainty (k=2)					$\pm 26 \%$	

The above measurement uncertainties are according to IEEE Std 1528

5300 MHz Body (SN: 3930)

Error Description	Uncertainty value $\pm\%$	Probability Distribution	Divisor	(Ci) 1g	Standard (1g)	vi 2 or Veff
Measurement System						
Probe calibration	± 6.55	Normal	1	1	$\pm 6.6 \%$	∞
Axial isotropy	± 4.7	Rectangular	$\sqrt{3}$	1	$\pm 2.7 \%$	∞
Hemispherical isotropy	± 9.6	Rectangular	$\sqrt{3}$	1	$\pm 5.5 \%$	∞
Boundary Effects	± 0.8	Rectangular	$\sqrt{3}$	1	$\pm 0.46 \%$	∞
Probe Linearity	± 4.7	Rectangular	$\sqrt{3}$	1	$\pm 2.7 \%$	∞
Probe modulation response	± 2.4	Rectangular	$\sqrt{3}$	1	$\pm 1.4 \%$	∞
Detection limits	± 0.25	Rectangular	$\sqrt{3}$	1	$\pm 0.14 \%$	∞
Readout Electronics	± 1.0	Normal	1	1	$\pm 1.0 \%$	∞
Response time	± 0.8	Rectangular	$\sqrt{3}$	1	$\pm 0.46 \%$	∞
Integration time	± 2.6	Rectangular	$\sqrt{3}$	1	$\pm 1.5 \%$	∞
RF Ambient Conditions – Noise	± 3.0	Rectangular	$\sqrt{3}$	1	$\pm 1.7 \%$	∞
RF Ambient Conditions – Reflections	± 3.0	Rectangular	$\sqrt{3}$	1	$\pm 1.7 \%$	∞
Probe Positioner	± 0.4	Rectangular	$\sqrt{3}$	1	$\pm 0.23 \%$	∞
Probe Positioning	± 2.9	Rectangular	$\sqrt{3}$	1	$\pm 1.7 \%$	∞
Algorithms for Max. SAR Eval.	± 1.0	Rectangular	$\sqrt{3}$	1	$\pm 0.58 \%$	∞
Test Sample Related						
Device Positioning	± 2.9	Normal	1	1	$\pm 2.9 \%$	145
Device Holder	± 3.6	Normal	1	1	$\pm 3.6 \%$	5
Power Drift	± 5.0	Rectangular	$\sqrt{3}$	1	$\pm 2.9 \%$	∞
SAR Scaling	± 2.0	Rectangular	$\sqrt{3}$	1	$\pm 1.2 \%$	∞
Physical Parameters						
Phantom Shell	± 4.0	Rectangular	$\sqrt{3}$	1	$\pm 2.3 \%$	∞
Liquid conductivity (Target)	± 5.0	Rectangular	$\sqrt{3}$	0.64	$\pm 2.9 \%$	∞
Liquid conductivity (Meas.)	± 3.9	Normal	1	0.64	$\pm 3.9 \%$	∞
Liquid permittivity (Target)	± 5.0	Rectangular	$\sqrt{3}$	0.6	$\pm 2.9 \%$	∞
Liquid permittivity (Meas.)	± 4.1	Normal	1	0.6	$\pm 4.1 \%$	∞
Temp. unc. - Conductivity	± 1.9	Rectangular	$\sqrt{3}$	0.78	$\pm 1.1 \%$	∞
Temp. unc. - Permittivity	± 1.9	Rectangular	$\sqrt{3}$	0.23	$\pm 1.1 \%$	∞
Combined Standard Uncertainty					$\pm 13 \%$	330
Expanded Uncertainty (k=2)					$\pm 26 \%$	

The above measurement uncertainties are according to IEEE Std 1528

5500 MHz Head (SN: 3930)

Error Description	Uncertainty value $\pm\%$	Probability Distribution	Divisor	(Ci) 1g	Standard (1g)	vi 2 or Veff
Measurement System						
Probe calibration	± 6.55	Normal	1	1	$\pm 6.6 \%$	∞
Axial isotropy	± 4.7	Rectangular	$\sqrt{3}$	1	$\pm 2.7 \%$	∞
Hemispherical isotropy	± 9.6	Rectangular	$\sqrt{3}$	1	$\pm 5.5 \%$	∞
Boundary Effects	± 0.8	Rectangular	$\sqrt{3}$	1	$\pm 0.46 \%$	∞
Probe Linearity	± 4.7	Rectangular	$\sqrt{3}$	1	$\pm 2.7 \%$	∞
Probe modulation response	± 2.4	Rectangular	$\sqrt{3}$	1	$\pm 1.4 \%$	∞
Detection limits	± 0.25	Rectangular	$\sqrt{3}$	1	$\pm 0.14 \%$	∞
Readout Electronics	± 1.0	Normal	1	1	$\pm 1.0 \%$	∞
Response time	± 0.8	Rectangular	$\sqrt{3}$	1	$\pm 0.46 \%$	∞
Integration time	± 2.6	Rectangular	$\sqrt{3}$	1	$\pm 1.5 \%$	∞
RF Ambient Conditions – Noise	± 3.0	Rectangular	$\sqrt{3}$	1	$\pm 1.7 \%$	∞
RF Ambient Conditions – Reflections	± 3.0	Rectangular	$\sqrt{3}$	1	$\pm 1.7 \%$	∞
Probe Positioner	± 0.4	Rectangular	$\sqrt{3}$	1	$\pm 0.23 \%$	∞
Probe Positioning	± 2.9	Rectangular	$\sqrt{3}$	1	$\pm 1.7 \%$	∞
Algorithms for Max. SAR Eval.	± 1.0	Rectangular	$\sqrt{3}$	1	$\pm 0.58 \%$	∞
Test Sample Related						
Device Positioning	± 2.9	Normal	1	1	$\pm 2.9 \%$	145
Device Holder	± 3.6	Normal	1	1	$\pm 3.6 \%$	5
Power Drift	± 5.0	Rectangular	$\sqrt{3}$	1	$\pm 2.9 \%$	∞
SAR Scaling	± 2.0	Rectangular	$\sqrt{3}$	1	$\pm 1.2 \%$	∞
Physical Parameters						
Phantom Shell	± 4.0	Rectangular	$\sqrt{3}$	1	$\pm 2.3 \%$	∞
Liquid conductivity (Target)	± 5.0	Rectangular	$\sqrt{3}$	0.64	$\pm 2.9 \%$	∞
Liquid conductivity (Meas.)	± 4.1	Normal	1	0.64	$\pm 4.1 \%$	∞
Liquid permittivity (Target)	± 5.0	Rectangular	$\sqrt{3}$	0.6	$\pm 2.9 \%$	∞
Liquid permittivity (Meas.)	± 3.9	Normal	1	0.6	$\pm 3.9 \%$	∞
Temp. unc. - Conductivity	± 1.8	Rectangular	$\sqrt{3}$	0.78	$\pm 1.0 \%$	∞
Temp. unc. - Permittivity	± 1.9	Rectangular	$\sqrt{3}$	0.23	$\pm 1.1 \%$	∞
Combined Standard Uncertainty					$\pm 13 \%$	330
Expanded Uncertainty (k=2)					$\pm 26 \%$	

The above measurement uncertainties are according to IEEE Std 1528

5500 MHz Body (SN: 3930)

Error Description	Uncertainty value $\pm\%$	Probability Distribution	Divisor	(Ci) 1g	Standard (1g)	vi 2 or Veff
Measurement System						
Probe calibration	± 6.55	Normal	1	1	$\pm 6.6 \%$	∞
Axial isotropy	± 4.7	Rectangular	$\sqrt{3}$	1	$\pm 2.7 \%$	∞
Hemispherical isotropy	± 9.6	Rectangular	$\sqrt{3}$	1	$\pm 5.5 \%$	∞
Boundary Effects	± 0.8	Rectangular	$\sqrt{3}$	1	$\pm 0.46 \%$	∞
Probe Linearity	± 4.7	Rectangular	$\sqrt{3}$	1	$\pm 2.7 \%$	∞
Probe modulation response	± 2.4	Rectangular	$\sqrt{3}$	1	$\pm 1.4 \%$	∞
Detection limits	± 0.25	Rectangular	$\sqrt{3}$	1	$\pm 0.14 \%$	∞
Readout Electronics	± 1.0	Normal	1	1	$\pm 1.0 \%$	∞
Response time	± 0.8	Rectangular	$\sqrt{3}$	1	$\pm 0.46 \%$	∞
Integration time	± 2.6	Rectangular	$\sqrt{3}$	1	$\pm 1.5 \%$	∞
RF Ambient Conditions – Noise	± 3.0	Rectangular	$\sqrt{3}$	1	$\pm 1.7 \%$	∞
RF Ambient Conditions – Reflections	± 3.0	Rectangular	$\sqrt{3}$	1	$\pm 1.7 \%$	∞
Probe Positioner	± 0.4	Rectangular	$\sqrt{3}$	1	$\pm 0.23 \%$	∞
Probe Positioning	± 2.9	Rectangular	$\sqrt{3}$	1	$\pm 1.7 \%$	∞
Algorithms for Max. SAR Eval.	± 1.0	Rectangular	$\sqrt{3}$	1	$\pm 0.58 \%$	∞
Test Sample Related						
Device Positioning	± 2.9	Normal	1	1	$\pm 2.9 \%$	145
Device Holder	± 3.6	Normal	1	1	$\pm 3.6 \%$	5
Power Drift	± 5.0	Rectangular	$\sqrt{3}$	1	$\pm 2.9 \%$	∞
SAR Scaling	± 2.0	Rectangular	$\sqrt{3}$	1	$\pm 1.2 \%$	∞
Physical Parameters						
Phantom Shell	± 4.0	Rectangular	$\sqrt{3}$	1	$\pm 2.3 \%$	∞
Liquid conductivity (Target)	± 5.0	Rectangular	$\sqrt{3}$	0.64	$\pm 2.9 \%$	∞
Liquid conductivity (Meas.)	± 3.8	Normal	1	0.64	$\pm 3.8 \%$	∞
Liquid permittivity (Target)	± 5.0	Rectangular	$\sqrt{3}$	0.6	$\pm 2.9 \%$	∞
Liquid permittivity (Meas.)	± 3.9	Normal	1	0.6	$\pm 3.9 \%$	∞
Temp. unc. - Conductivity	± 1.7	Rectangular	$\sqrt{3}$	0.78	$\pm 1.0 \%$	∞
Temp. unc. - Permittivity	± 1.8	Rectangular	$\sqrt{3}$	0.23	$\pm 1.0 \%$	∞
Combined Standard Uncertainty					$\pm 13 \%$	330
Expanded Uncertainty (k=2)					$\pm 26 \%$	

The above measurement uncertainties are according to IEEE Std 1528

5600 MHz Head (SN: 3930)

Error Description	Uncertainty value $\pm\%$	Probability Distribution	Divisor	(Ci) 1g	Standard (1g)	vi 2 or Veff
Measurement System						
Probe calibration	± 6.55	Normal	1	1	$\pm 6.6 \%$	∞
Axial isotropy	± 4.7	Rectangular	$\sqrt{3}$	1	$\pm 2.7 \%$	∞
Hemispherical isotropy	± 9.6	Rectangular	$\sqrt{3}$	1	$\pm 5.5 \%$	∞
Boundary Effects	± 0.8	Rectangular	$\sqrt{3}$	1	$\pm 0.46 \%$	∞
Probe Linearity	± 4.7	Rectangular	$\sqrt{3}$	1	$\pm 2.7 \%$	∞
Probe modulation response	± 2.4	Rectangular	$\sqrt{3}$	1	$\pm 1.4 \%$	∞
Detection limits	± 0.25	Rectangular	$\sqrt{3}$	1	$\pm 0.14 \%$	∞
Readout Electronics	± 1.0	Normal	1	1	$\pm 1.0 \%$	∞
Response time	± 0.8	Rectangular	$\sqrt{3}$	1	$\pm 0.46 \%$	∞
Integration time	± 2.6	Rectangular	$\sqrt{3}$	1	$\pm 1.5 \%$	∞
RF Ambient Conditions – Noise	± 3.0	Rectangular	$\sqrt{3}$	1	$\pm 1.7 \%$	∞
RF Ambient Conditions – Reflections	± 3.0	Rectangular	$\sqrt{3}$	1	$\pm 1.7 \%$	∞
Probe Positioner	± 0.4	Rectangular	$\sqrt{3}$	1	$\pm 0.23 \%$	∞
Probe Positioning	± 2.9	Rectangular	$\sqrt{3}$	1	$\pm 1.7 \%$	∞
Algorithms for Max. SAR Eval.	± 1.0	Rectangular	$\sqrt{3}$	1	$\pm 0.58 \%$	∞
Test Sample Related						
Device Positioning	± 2.9	Normal	1	1	$\pm 2.9 \%$	145
Device Holder	± 3.6	Normal	1	1	$\pm 3.6 \%$	5
Power Drift	± 5.0	Rectangular	$\sqrt{3}$	1	$\pm 2.9 \%$	∞
SAR Scaling	± 2.0	Rectangular	$\sqrt{3}$	1	$\pm 1.2 \%$	∞
Physical Parameters						
Phantom Shell	± 4.0	Rectangular	$\sqrt{3}$	1	$\pm 2.3 \%$	∞
Liquid conductivity (Target)	± 5.0	Rectangular	$\sqrt{3}$	0.64	$\pm 2.9 \%$	∞
Liquid conductivity (Meas.)	± 3.9	Normal	1	0.64	$\pm 3.9 \%$	∞
Liquid permittivity (Target)	± 5.0	Rectangular	$\sqrt{3}$	0.6	$\pm 2.9 \%$	∞
Liquid permittivity (Meas.)	± 4.2	Normal	1	0.6	$\pm 4.2 \%$	∞
Temp. unc. - Conductivity	± 2.0	Rectangular	$\sqrt{3}$	0.78	$\pm 1.2 \%$	∞
Temp. unc. - Permittivity	± 1.9	Rectangular	$\sqrt{3}$	0.23	$\pm 1.1 \%$	∞
Combined Standard Uncertainty					$\pm 13 \%$	330
Expanded Uncertainty (k=2)					$\pm 26 \%$	

The above measurement uncertainties are according to IEEE Std 1528

5600 MHz Body (SN: 3930)

Error Description	Uncertainty value $\pm\%$	Probability Distribution	Divisor	(Ci) 1g	Standard (1g)	vi 2 or Veff
Measurement System						
Probe calibration	± 6.55	Normal	1	1	$\pm 6.6 \%$	∞
Axial isotropy	± 4.7	Rectangular	$\sqrt{3}$	1	$\pm 2.7 \%$	∞
Hemispherical isotropy	± 9.6	Rectangular	$\sqrt{3}$	1	$\pm 5.5 \%$	∞
Boundary Effects	± 0.8	Rectangular	$\sqrt{3}$	1	$\pm 0.46 \%$	∞
Probe Linearity	± 4.7	Rectangular	$\sqrt{3}$	1	$\pm 2.7 \%$	∞
Probe modulation response	± 2.4	Rectangular	$\sqrt{3}$	1	$\pm 1.4 \%$	∞
Detection limits	± 0.25	Rectangular	$\sqrt{3}$	1	$\pm 0.14 \%$	∞
Readout Electronics	± 1.0	Normal	1	1	$\pm 1.0 \%$	∞
Response time	± 0.8	Rectangular	$\sqrt{3}$	1	$\pm 0.46 \%$	∞
Integration time	± 2.6	Rectangular	$\sqrt{3}$	1	$\pm 1.5 \%$	∞
RF Ambient Conditions – Noise	± 3.0	Rectangular	$\sqrt{3}$	1	$\pm 1.7 \%$	∞
RF Ambient Conditions – Reflections	± 3.0	Rectangular	$\sqrt{3}$	1	$\pm 1.7 \%$	∞
Probe Positioner	± 0.4	Rectangular	$\sqrt{3}$	1	$\pm 0.23 \%$	∞
Probe Positioning	± 2.9	Rectangular	$\sqrt{3}$	1	$\pm 1.7 \%$	∞
Algorithms for Max. SAR Eval.	± 1.0	Rectangular	$\sqrt{3}$	1	$\pm 0.58 \%$	∞
Test Sample Related						
Device Positioning	± 2.9	Normal	1	1	$\pm 2.9 \%$	145
Device Holder	± 3.6	Normal	1	1	$\pm 3.6 \%$	5
Power Drift	± 5.0	Rectangular	$\sqrt{3}$	1	$\pm 2.9 \%$	∞
SAR Scaling	± 2.0	Rectangular	$\sqrt{3}$	1	$\pm 1.2 \%$	∞
Physical Parameters						
Phantom Shell	± 4.0	Rectangular	$\sqrt{3}$	1	$\pm 2.3 \%$	∞
Liquid conductivity (Target)	± 5.0	Rectangular	$\sqrt{3}$	0.64	$\pm 2.9 \%$	∞
Liquid conductivity (Meas.)	± 3.9	Normal	1	0.64	$\pm 3.9 \%$	∞
Liquid permittivity (Target)	± 5.0	Rectangular	$\sqrt{3}$	0.6	$\pm 2.9 \%$	∞
Liquid permittivity (Meas.)	± 4.1	Normal	1	0.6	$\pm 4.1 \%$	∞
Temp. unc. - Conductivity	± 1.9	Rectangular	$\sqrt{3}$	0.78	$\pm 1.1 \%$	∞
Temp. unc. - Permittivity	± 1.9	Rectangular	$\sqrt{3}$	0.23	$\pm 1.1 \%$	∞
Combined Standard Uncertainty					$\pm 13 \%$	330
Expanded Uncertainty (k=2)					$\pm 26 \%$	

The above measurement uncertainties are according to IEEE Std 1528

5800 MHz Head (SN: 3930)

Error Description	Uncertainty value $\pm\%$	Probability Distribution	Divisor	(Ci) 1g	Standard (1g)	vi 2 or Veff
Measurement System						
Probe calibration	± 6.55	Normal	1	1	$\pm 6.6 \%$	∞
Axial isotropy	± 4.7	Rectangular	$\sqrt{3}$	1	$\pm 2.7 \%$	∞
Hemispherical isotropy	± 9.6	Rectangular	$\sqrt{3}$	1	$\pm 5.5 \%$	∞
Boundary Effects	± 0.8	Rectangular	$\sqrt{3}$	1	$\pm 0.46 \%$	∞
Probe Linearity	± 4.7	Rectangular	$\sqrt{3}$	1	$\pm 2.7 \%$	∞
Probe modulation response	± 2.4	Rectangular	$\sqrt{3}$	1	$\pm 1.4 \%$	∞
Detection limits	± 0.25	Rectangular	$\sqrt{3}$	1	$\pm 0.14 \%$	∞
Readout Electronics	± 1.0	Normal	1	1	$\pm 1.0 \%$	∞
Response time	± 0.8	Rectangular	$\sqrt{3}$	1	$\pm 0.46 \%$	∞
Integration time	± 2.6	Rectangular	$\sqrt{3}$	1	$\pm 1.5 \%$	∞
RF Ambient Conditions – Noise	± 3.0	Rectangular	$\sqrt{3}$	1	$\pm 1.7 \%$	∞
RF Ambient Conditions – Reflections	± 3.0	Rectangular	$\sqrt{3}$	1	$\pm 1.7 \%$	∞
Probe Positioner	± 0.4	Rectangular	$\sqrt{3}$	1	$\pm 0.23 \%$	∞
Probe Positioning	± 2.9	Rectangular	$\sqrt{3}$	1	$\pm 1.7 \%$	∞
Algorithms for Max. SAR Eval.	± 1.0	Rectangular	$\sqrt{3}$	1	$\pm 0.58 \%$	∞
Test Sample Related						
Device Positioning	± 2.9	Normal	1	1	$\pm 2.9 \%$	145
Device Holder	± 3.6	Normal	1	1	$\pm 3.6 \%$	5
Power Drift	± 5.0	Rectangular	$\sqrt{3}$	1	$\pm 2.9 \%$	∞
SAR Scaling	± 2.0	Rectangular	$\sqrt{3}$	1	$\pm 1.2 \%$	∞
Physical Parameters						
Phantom Shell	± 4.0	Rectangular	$\sqrt{3}$	1	$\pm 2.3 \%$	∞
Liquid conductivity (Target)	± 5.0	Rectangular	$\sqrt{3}$	0.64	$\pm 2.9 \%$	∞
Liquid conductivity (Meas.)	± 4.1	Normal	1	0.64	$\pm 4.1 \%$	∞
Liquid permittivity (Target)	± 5.0	Rectangular	$\sqrt{3}$	0.6	$\pm 2.9 \%$	∞
Liquid permittivity (Meas.)	± 3.8	Normal	1	0.6	$\pm 3.8 \%$	∞
Temp. unc. - Conductivity	± 1.8	Rectangular	$\sqrt{3}$	0.78	$\pm 1.0 \%$	∞
Temp. unc. - Permittivity	± 1.8	Rectangular	$\sqrt{3}$	0.23	$\pm 1.0 \%$	∞
Combined Standard Uncertainty					$\pm 13 \%$	330
Expanded Uncertainty (k=2)					$\pm 26 \%$	

The above measurement uncertainties are according to IEEE Std 1528

5800 MHz Body (SN: 3930)

Error Description	Uncertainty value $\pm\%$	Probability Distribution	Divisor	(Ci) 1g	Standard (1g)	vi 2 or Veff
Measurement System						
Probe calibration	± 6.55	Normal	1	1	$\pm 6.6 \%$	∞
Axial isotropy	± 4.7	Rectangular	$\sqrt{3}$	1	$\pm 2.7 \%$	∞
Hemispherical isotropy	± 9.6	Rectangular	$\sqrt{3}$	1	$\pm 5.5 \%$	∞
Boundary Effects	± 0.8	Rectangular	$\sqrt{3}$	1	$\pm 0.46 \%$	∞
Probe Linearity	± 4.7	Rectangular	$\sqrt{3}$	1	$\pm 2.7 \%$	∞
Probe modulation response	± 2.4	Rectangular	$\sqrt{3}$	1	$\pm 1.4 \%$	∞
Detection limits	± 0.25	Rectangular	$\sqrt{3}$	1	$\pm 0.14 \%$	∞
Readout Electronics	± 1.0	Normal	1	1	$\pm 1.0 \%$	∞
Response time	± 0.8	Rectangular	$\sqrt{3}$	1	$\pm 0.46 \%$	∞
Integration time	± 2.6	Rectangular	$\sqrt{3}$	1	$\pm 1.5 \%$	∞
RF Ambient Conditions – Noise	± 3.0	Rectangular	$\sqrt{3}$	1	$\pm 1.7 \%$	∞
RF Ambient Conditions – Reflections	± 3.0	Rectangular	$\sqrt{3}$	1	$\pm 1.7 \%$	∞
Probe Positioner	± 0.4	Rectangular	$\sqrt{3}$	1	$\pm 0.23 \%$	∞
Probe Positioning	± 2.9	Rectangular	$\sqrt{3}$	1	$\pm 1.7 \%$	∞
Algorithms for Max. SAR Eval.	± 1.0	Rectangular	$\sqrt{3}$	1	$\pm 0.58 \%$	∞
Test Sample Related						
Device Positioning	± 2.9	Normal	1	1	$\pm 2.9 \%$	145
Device Holder	± 3.6	Normal	1	1	$\pm 3.6 \%$	5
Power Drift	± 5.0	Rectangular	$\sqrt{3}$	1	$\pm 2.9 \%$	∞
SAR Scaling	± 2.0	Rectangular	$\sqrt{3}$	1	$\pm 1.2 \%$	∞
Physical Parameters						
Phantom Shell	± 4.0	Rectangular	$\sqrt{3}$	1	$\pm 2.3 \%$	∞
Liquid conductivity (Target)	± 5.0	Rectangular	$\sqrt{3}$	0.64	$\pm 2.9 \%$	∞
Liquid conductivity (Meas.)	± 4.0	Normal	1	0.64	$\pm 4.0 \%$	∞
Liquid permittivity (Target)	± 5.0	Rectangular	$\sqrt{3}$	0.6	$\pm 2.9 \%$	∞
Liquid permittivity (Meas.)	± 4.1	Normal	1	0.6	$\pm 4.1 \%$	∞
Temp. unc. - Conductivity	± 1.9	Rectangular	$\sqrt{3}$	0.78	$\pm 1.1 \%$	∞
Temp. unc. - Permittivity	± 1.8	Rectangular	$\sqrt{3}$	0.23	$\pm 1.0 \%$	∞
Combined Standard Uncertainty					$\pm 13 \%$	330
Expanded Uncertainty (k=2)					$\pm 26 \%$	

The above measurement uncertainties are according to IEEE Std 1528

16. CONCLUSION

Measurement Conclusion

The SAR measurement indicates that the EUT complies with the RF radiation exposure limits of the FCC. These measurements are taken to simulate the RF effects exposure under the worst-case conditions. Precise laboratory measures were taken to assure repeatability of the tests. The tested device complies with the requirements in respect to all parameters subject to the test. The test results and statements relate only to the item(s) tested.

Please note that the absorption and distribution of electromagnetic energy in the body are every complex phenomena that depend on the mass, shape, and size of the body, the orientation of the body with respect to the field vectors, and the electrical properties of both the body and the environment. Other variables that may play a substantial role impossible biological effect are those that characterize the environment (e.g. ambient temperature, air velocity, relative humidity, and body insulation) and those that characterize the individual (e.g. age, gender, activity level, debilitation, or disease).

Because innumerable factors may interact to determine the specific biological outcome of an exposure to electromagnetic fields, any protection guide shall consider maximal amplification of biological effects as a result of field-body interactions, environmental conditions, and physiological variables.

17. REFERENCES

- [1] Federal Communications Commission, ET Docket 93-62, Guidelines for Evaluating the Environmental Effects of Radiofrequency Radiation, Aug. 1996.
- [2] ANSI/IEEE C95.1-2005, American National Standard safety levels with respect to human exposure to radiofrequency electromagnetic fields, 3kHz to 300GHz, New York: IEEE, 2006.
- [3] ANSI/IEEE C95.1-1992, American National Standard safety levels with respect to human exposure to radiofrequency electromagnetic fields, 3kHz to 300GHz, New York: IEEE, Sept. 1992.
- [4] ANSI/IEEE C95.3-2002, IEEE Recommended Practice for the Measurement of Potentially Hazardous Electromagnetic Fields - RF and Microwave, New York: IEEE, December 2002.
- [5] IEEE Standards Coordinating Committee 39 –Standards Coordinating Committee 34 – IEEE Std. 1528-2003, Recommended Practice for Determining the Peak Spatial-Average Specific Absorption Rate (SAR) in the Human Body Due to Wireless Communications Devices.
- [6] NCRP, National Council on Radiation Protection and Measurements, Biological Effects and Exposure Criteria for Radio Frequency Electromagnetic Fields, NCRP Report No. 86, 1986. Reprinted Feb. 1995.
- [7] T. Schmid, O. Egger, N. Kuster, Automated E-field scanning system for dosimetric assessments, IEEE Transaction on Microwave Theory and Techniques, vol. 44, Jan. 1996, pp. 105-113.
- [8] K. Pokovic, T. Schmid, N. Kuster, Robust setup for precise calibration of E-field probes in tissue simulating liquids at mobile communications frequencies, ICECOM97, Oct. 1997, pp. -124.
- [9] K. Pokovic, T. Schmid, and N. Kuster, E-field Probe with improved isotropy in brain simulating liquids, Proceedings of the ELMAR, Zadar, Croatia, June 23-25, 1996, pp. 172-175.
- [10] Schmid & Partner Engineering AG, Application Note: Data Storage and Evaluation, June 1998, p2.
- [11] V. Hombach, K. Meier, M. Burkhardt, E. Kuhn, N. Kuster, The Dependence of EM Energy Absorption upon Human Modeling at 900 MHz, IEEE Transaction on Microwave Theory and Techniques, vol. 44 no. 10, Oct. 1996, pp. 1865-1873.
- [12] N. Kuster and Q. Balzano, Energy absorption mechanism by biological bodies in the near field of dipole antennas above 300MHz, IEEE Transaction on Vehicular Technology, vol. 41, no. 1, Feb. 1992, pp. 17-23.
- [13] G. Hartsgrrove, A. Kraszewski, A. Surowiec, Simulated Biological Materials for Electromagnetic Radiation Absorption Studies, University of Ottawa, Bio electromagnetics, Canada: 1987, pp. 29-36.
- [14] Q. Balzano, O. Garay, T. Manning Jr., Electromagnetic Energy Exposure of Simulated Users of Portable Cellular Telephones, IEEE Transactions on Vehicular Technology, vol. 44, no.3, Aug. 1995.
- [15] W. Gander, Computer mathematick, Birkhaeuser, Basel, 1992.
- [16] W.H. Press, S.A. Teukolsky, W.T. Vetterling, and B.P. Flannery, Numerical Recipes in C, The Art of Scientific Computing, Second edition, Cambridge University Press, 1992.
- [17] N. Kuster, R. Kastle, T. Schmid, Dosimetric evaluation of mobile communications equipment with known precision, IEEE Transaction on Communications, vol. E80-B, no. 5, May 1997, pp. 645-652.
- [18] CENELEC CLC/SC111B, European Prestandard (prENV 50166-2), Human Exposure to Electromagnetic Fields High-frequency: 10kHz-300GHz, Jan. 1995.
- [19] Prof. Dr. Niels Kuster, ETH, Eidgenössische Technische Hochschule Zürich, Dosimetric Evaluation of the Cellular Phone.

- [20] IEC 62209-1, Human exposure to radio frequency fields from hand-held and body-mounted wireless communication devices - Human models, instrumentation, and procedures - Part 1: Procedure to determine the specific absorption rate (SAR) for hand-held devices used in close proximity to the ear (frequency range of 300MHz to 3 GHz), Feb. 2005.
- [21] Industry Canada RSS-102 Radio Frequency Exposure Compliance of Radio communication Apparatus (All Frequency Bands) Issue 5, March 2015.
- [22] Health Canada Safety Code 6 Limits of Human Exposure to Radio Frequency Electromagnetic Fields in the Frequency Range from 3 kHz – 300 GHz, 2009
- [23] FCC SAR Test Procedures for 2G-3G Devices, Mobile Hotspot and UMPC Devices KDB Publications 941225,D01-D07
- [24] SAR Measurement procedures for IEEE 802.11a/b/g KDB Publication 248227 D01v02
- [25] FCC SAR Considerations for Handsets with Multiple Transmitters and Antennas, KDB Publications 648474D02-D04
- [26] FCC SAR Evaluation Considerations for Laptop, Notebook, Netbook and Tablet Computers, FCC KDB Publication 616217 D04
- [27] FCC SAR Measurement and Reporting Requirements for 100MHz – 6 GHz, KDB Publications 865664 D01-D02
- [28] FCC General RF Exposure Guidance and SAR Procedures for Dongles, KDB Publication 447498, D01-D02
- [29] 615223 D01 802 16e WI-Max SAR Guidance v01, Nov. 13, 2009
- [30] Anexo à Resolução No. 533, de 10 de September de 2009.
- [31] IEC 62209-2, Human exposure to radio frequency fields from hand-held and body-mounted wireless communication devices - Human models, instrumentation, and procedures - Part 2: Procedure to determine the specific absorption rate (SAR) for wireless communication devices used in close proximity to the human body(frequency range of 30 MHz to 6 GHz), Mar. 2010.