



FCC TEST REPORT

Reference No. : G-45-2011-02450
 Applicant : LG Electronics MobileComm U.S.A., Inc.
 Equipment Under Test (EUT) :
 Product Name : Cellular/PCS GSM/GPRS/EDGE and PCS
 WCDMA/HSUPA Phone with Bluetooth,
 WLAN and NFC
 Model Name : LG-P940
 Applied Standards : FCC Part 15 : 2010, Subpart B, Class B
 ANSI C63.4 : 2003
 CISPR 22 : 2006
 Date of Receipt : September 05, 2011
 Date of Test : September 26, 2011 ~ September 30, 2011
 Date of Issue : October 04, 2011
 Test Results : Complied

Tested by	:	 ----- Paul Kang
Reviewed by	:	 ----- Forest Lee

Remarks :

This report details the results of the testing carried out on one sample, the results contained in this test report do not relate to other samples of the same product. The manufacturer should ensure that all products in series production are in conformity with the product sample detailed in this report.

This report may only be reproduced and distributed in full. If the product in this report is used in any configuration other than that detailed in the report, the manufacturer must ensure the new system complies with all relevant standards. Any mention of SGS International Electrical Approvals or Testing done by SGS International Electrical Approvals in connection with distribution or use of the product described in this report must be approved by SGS international Electrical Approvals in writing.

Contents

1. General Information.....	3
1.1 Client Information.....	3
1.2 Test Laboratory.....	3
1.3 General Information of E.U.T.	3
1.4 Operating Modes and Conditions.....	3
1.5 Auxiliary Equipments	4
1.6 Cable List.....	4
1.7 System Configurations.....	5
1.8 Test System Layout	6
1.9 Modifications	6
1.10 Applicable Standards for Testing	6
1.11 Summary of Test Results.....	6
2. Emission Test.....	7
2.1 Test Results	7
2.2 Test Method and Limits.....	7
2.2.1 Test Method	7
2.2.2 Test Limits.....	7
2.3 Conducted Emission	8
2.3.1 Test Equipments	8
2.3.2 Test Site.....	8
2.3.3 Environment Conditions	9
2.4 Radiated Emission	10
2.4.1 Test Equipments	10
2.4.2 Test Site.....	10
2.4.3 Environment Conditions	11
Appendix A : Conducted Emission	13
Appendix B : Radiated Emission	15

1. General Information

1.1 Client Information

Applicant : LG Electronics MobileComm U.S.A., Inc.
 Address of Applicant : 10101 Old Grove Road, San Diego, CA 92131
 Manufacturer : LG Electronics MobileComm U.S.A., Inc.
 Address of Manufacturer : 10101 Old Grove Road, San Diego, CA 92131

1.2 Test Laboratory

Name and Address : SGS Korea Co., Ltd.
 18-34, Sanbon-dong, Gunpo, Gyeonggi-do, Korea
 435-040
 FCC Registration No. : 367021
 IC Company No. : 4620F
 Phone : + 82 31 428 5700
 Fax : + 82 31 427 2370
 e-mail : forest.lee@sgs.com

1.3 General Information of E.U.T.

Product Name	Cellular/PCS GSM/GPRS/EDGE and PCS WCDMA/HSUPA Phone with Bluetooth, WLAN and NFC
Model Name	LG-P940
Serial No.	N/A
FCC ID	ZNFP940
EMI Classification	Class B
Highest Internal Frequency	Max. 1 GHz
Test Voltage	120 Va.c., 60 Hz (from Notebook Computer)
Battery	3.7 Vd.c., 1540 mAh, 5.7 Wh

1.4 Operating Modes and Conditions

Operating mode	Operating condition
Mode 1 USB Mode	USB Data Communication
Mode 2 HDMI Mode	HDMI Mode

Note : The EUT was exercised through batch file during testing.

1.5 Auxiliary Equipments

Description	Model	Serial No.	Manufacturer
USB Mouse	Basic Optical Mouse 1.0A USB/PS2 Compatible	-	MICROSOFT CORPORATION
Micro SD Card	Mobile Ultra 2GB	-	SanDisk
Notebook Computer	LGX14	008QTEQ024836	LG
LCD Monitor	W2261VT	003NDWEKY873	LG

Note: Auxiliary equipments are declared according to FCC DoC procedure.

1.6 Cable List

Start		END		Cable Spec.	
Name	I/O Port	Name	I/O Port	Length	Shield
HDMI Mode					
Phone	USB	HDMI Gender	-	-	-
	IO	Ear-MIC Phone	-	1.1	Unshield
	Micro SD	Micro SD Card	-	-	-
HDMI Gender	-	Phone	USB	-	-
	-	Notebook Computer	USB	1.2	Shield
	HDMI	LCD Monitor	HDMI	1.8	Shield
LCD Monitor	AC IN	AC Source	-	1.0	Unshield
	HDMI	HDMI Gender	HDMI	1.8	Shield
Notebook Computer	USB	HDMI Gender	-	1.2	Shield
	USB	USB Mouse	USB	1.8	Shield
	DC IN	AC Adapter	DC OUT	1.2	Unshield
AC Adapter	DC OUT	Notebook Computer	DC IN	1.2	Unshield
	AC IN	AC Source	-	1.0	Unshield

Start		END		Cable Spec.	
Name	I/O Port	Name	I/O Port	Length	Shield
USB Mode					
Phone	USB	Notebook Computer	USB	1.2	Shield
	IO	Ear-MIC Phone	-	1.1	Unshield
	Micro SD	Micro SD Card	-	-	-
Notebook Computer	USB	Phone	USB	1.2	Shield
	USB	USB Mouse	USB	1.8	Shield
	DC IN	AC Adapter	DC OUT	1.2	Unshield
AC Adapter	DC OUT	Notebook Computer	DC IN	1.2	Unshield
	AC IN	AC Source	-	1.0	Unshield

1.7 System Configurations

Description	Model	Serial No.	Manufacturer
Ear-MIC Phone	-	-	PRADA
Battery	BL-44JR	EAC61738201 LLL	LG
HDMI Gender	SDT-600	AB1FP000038	PRADA

1.8 Test System Layout

-HDMI Mode

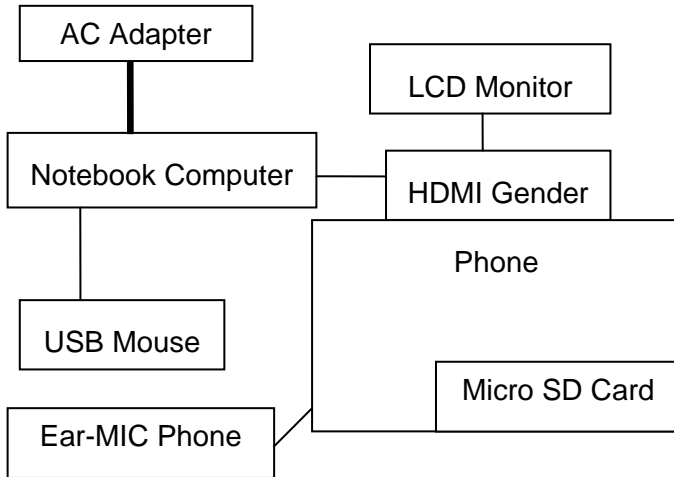

-USB Mode

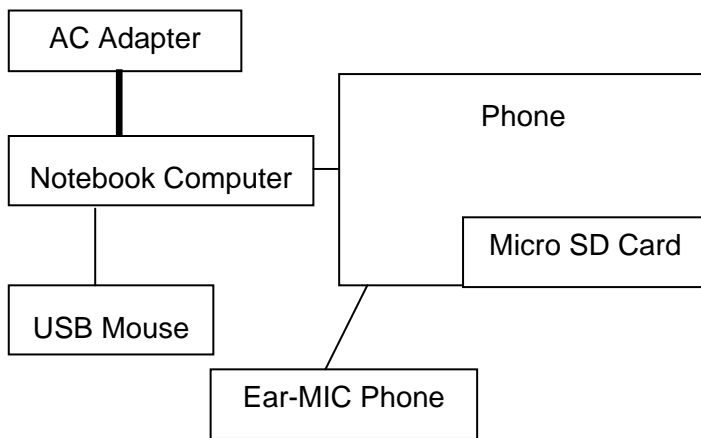

1.9 Modifications

There was no modified item during the test.

1.10 Applicable Standards for Testing

Standards	Status	Deviation
FCC Part 15 : 2010, Subpart B	Applicable	No Deviation

1.11 Summary of Test Results

Test Item	Basic Standards	Results
Conducted Emission	ANSI C63.4 : 2003	Complied
Radiated Emission	ANSI C63.4 : 2003	Complied

Note : Test methods of all test items are performed according to the basic standards in this table.

EMISSION

2.1 Test Results

Test Items	Basic Standards	Test Results
Conducted Emission	ANSI C63.4 : 2003	Complied
Radiated Emission	ANSI C63.4 : 2003	Complied

2.2 Test Method and Limits

2.2.1 Test Method

Test Items	Measuring Frequency Range	RBW	Measuring Distance
Conducted Emission	0.15 MHz ~ 30 MHz	9 kHz	N/A
Radiated Emission	30 MHz ~ 1 GHz	120 kHz	10 m & 3 m
	Above 1 GHz	1 MHz	3 m

Note : 10 m method of radiated emission measurement is only applied to Class A equipment over the frequency range of 30 MHz ~ 1 GHz. Except this, 3 m method is applied to Class B equipment over the frequency range of 30 MHz ~ 1 GHz and Class A and Class B equipment above 1 GHz.

2.2.2 Test Limits

-Conducted Emission Limits

Frequency Range	Limits(dB(μ V))		Class
	Quasi-peak	Average	
0.15 MHz ~ 0.5 MHz	79	66	Class A
0.5 MHz ~ 30 MHz	73	60	
0.15 MHz ~ 0.5 MHz	66 to 56	56 to 46	Class B
0.5 MHz ~ 5 MHz	56	46	
5 MHz ~ 30 MHz	60	50	

Note : The lower limit shall apply at the transition frequencies. The limit decreases linearly with the logarithm of the frequency in the range 0.15 MHz to 0.5 MHz.

-Radiated Emission Limits below 1 GHz

Frequency Range	Limits(dB(μ V/m))		Class
	Quasi-peak		
30 MHz ~ 88 MHz	39.1		Class A
88 MHz ~ 216 MHz	43.5		
216 MHz ~ 960 MHz	46.4		
960 MHz ~ 1 GHz	49.5		
30 MHz ~ 88 MHz	40		Class B
88 MHz ~ 216 MHz	43.5		
216 MHz ~ 960 MHz	46		
960 MHz ~ 1 GHz	54		

-Radiated Emission Limits above 1 GHz

Frequency Range	Limits(dB(μ V/m))		Class
	Average	Peak	
Above 1 GHz	60	80	Class A
Above 1 GHz	54	74	Class B

Note : The limits of class A equipment is extrapolated using an extrapolation factor of 20 dB/decade because it was measured at 3m distance not 10m distance.

2.3 Conducted Emission

The initial preliminary exploratory scans were performed over the measuring frequency range(0.15 MHz to 30 MHz) using a max hold mode incorporating a Peak detector and Average detector and using the software of ES-K1(Version V1.71 from R&S). The final test data was measured using a Quasi-Peak detector and Average detector.

2.3.1 Test Equipments

Description	Model No.	Manufacturer	S/N	Last Cal. Date
Two-Line V-Network	ENV216	R & S	100190	2011.01.06
Artificial Mains Networks	ESH2-Z5	R & S	100280	2011.04.06
Test Receiver	ESHS10	R & S	863365/018	2011.07.07

2.3.2 Test Site

Shield Room in Gunpo Laboratory

2.3.3 Environment Conditions

Temperature : 25.0

Humidity : 41.0 %R.H.

Atmospheric Pressure : 100.4 kPa

Test Date : September 26, 2011

-USB Mode

Freq. (MHz)	Line (H/N)	Level (dB μ V)		CL (dB)	LISN (dB)	Result (dB μ V)		Limit (dB μ V)		Margin (dB)	
		Q/P	A/V			Q/P	A/V	Q/P	A/V	Q/P	A/V
0.20	H	41.80	28.10	0.40	9.57	51.77	38.07	63.61	53.61	11.84	15.54
0.26	H	34.80	19.40	0.46	9.57	44.83	29.43	61.59	51.59	16.76	22.16
0.27	N	34.00	18.00	0.47	9.65	44.12	28.12	61.27	51.27	17.15	23.15
0.33	N	29.90	14.40	0.55	9.65	40.10	24.60	59.58	49.58	19.48	24.98
13.63	N	22.30	15.60	0.26	9.75	32.31	25.61	60.00	50.00	27.69	24.39
13.97	H	22.10	16.70	0.30	9.64	32.04	26.64	60.00	50.00	27.96	23.36

-HDMI Mode

Freq. (MHz)	Line (H/N)	Level (dB μ V)		CL (dB)	LISN (dB)	Result (dB μ V)		Limit (dB μ V)		Margin (dB)	
		Q/P	A/V			Q/P	A/V	Q/P	A/V	Q/P	A/V
0.16	N	42.60	26.20	0.31	9.65	52.56	36.16	65.73	55.73	13.17	19.57
0.19	N	38.70	22.50	0.37	9.65	48.72	32.52	64.26	54.26	15.54	21.74
0.20	H	36.60	11.60	0.39	9.57	46.56	21.56	63.82	53.82	17.26	32.26
0.22	N	34.00	19.10	0.42	9.65	44.07	29.17	62.82	52.82	18.75	23.65
0.24	H	32.60	19.90	0.44	9.57	42.61	29.91	62.27	52.27	19.66	22.36
0.25	N	31.50	18.10	0.45	9.65	41.60	28.20	61.76	51.76	20.16	23.56

Measurement Uncertainty : ± 3.37 dB (The confidential level is about 95%, K=2)

- Note :
- Line (H) : Hot
 - Line (N) : Neutral
 - C/L: Cable Loss
 - LISN : LISN Factor
 - Result = Level + CL + LISN
 - Margin = Limit – Result

See Appendix A (Conducted Emission)

2.4 Radiated Emission

The initial preliminary exploratory scans were performed over the measuring frequency range(30 MHz to 5 GHz) using a max hold mode incorporating a Peak detector and using the software of EP5RE(Version Ver3.10.20 from TOYO). The final test data was measured using a Quasi-Peak detector below 1 GHz and a Peak and Average detector above 1 GHz. Measurements were made with the antenna positioned in both the horizontal and vertical planes of polarization. The antenna height was varied from 1 m to 4 m and the EUT was rotated 360° to find the maximum emitting point for each frequency.

2.4.1 Test Equipments

Description	Model No.	Manufacturer	S/N	Last Cal. Date
Horn Antenna	HF906	R & S	100326	2009.10.08
Signal Conditioning Unit	SCU 18	R & S	10117	2011.03.23
Bilog Antenna	VULB9163	SCHWARZBEC K MESS- ELEKTRONIK	396	2011.04.07
Test Receiver	ESU26	R & S	100109	2011.04.27
Amplifier	8447F	HP	2944A03909	2011.07.04

Note : Only the calibration period of Antennas is 2 years but the period of every equipment is 1 year.

2.4.2 Test Site

3 m Semi-Anechoic Chamber in Gunpo Laboratory

2.4.3 Environment Conditions

Below 1 GHz (3 m method)

Temperature : 19.8

Humidity : 31.0 %R.H.

Atmospheric Pressure : 100.3 kPa

Test Date : September 30, 2011

-USB Mode

Freq. (MHz)	Level (dB μ V)	Pol. (H/V)	A (°)	H (m)	AF (dB)	CL (dB)	Amp. (dB)	F/S (dB μ V/m)	Limit (dB μ V/m)	Margin (dB)
60.31	45.40	H	258.7	4.00	12.66	1.11	27.18	31.99	40.00	8.01
200.48	47.30	H	109.2	2.10	11.00	2.08	26.70	33.68	43.50	9.82
320.03	44.50	H	179.8	1.00	12.85	2.53	26.97	32.91	46.00	13.09
449.73	46.40	H	188.8	2.00	14.84	3.22	27.55	36.91	46.00	9.09
904.90	39.60	H	179.7	1.00	22.06	4.39	27.39	38.66	46.00	7.34

-HDMI Mode

Freq. (MHz)	Level (dB μ V)	Pol. (H/V)	A (°)	H (m)	AF (dB)	CL (dB)	Amp. (dB)	F/S (dB μ V/m)	Limit (dB μ V/m)	Margin (dB)
84.68	48.30	V	243.4	1.00	8.72	1.34	27.38	30.98	40.00	9.02
100.20	44.20	H	252.5	3.00	11.79	1.45	27.50	29.94	43.50	13.56
137.15	48.30	V	14.4	1.00	8.67	1.64	27.20	31.41	43.50	12.09
157.43	50.10	H	233.4	2.10	8.79	1.77	27.04	33.62	43.50	9.88
202.09	49.70	H	196.2	1.90	11.05	2.09	26.70	36.14	43.50	7.36
308.27	47.30	H	62.4	1.00	12.72	2.48	26.69	35.81	46.00	10.19

Measurement Uncertainty (Horizontal) : \pm 5.00 dB (The confidential level is about 95%, K=2)

Measurement Uncertainty (Vertical) : \pm 5.36 dB (The confidential level is about 95%, K=2)

- Note:
- AF = Antenna Factor
 - CL = Cable Loss
 - F/S = Field Strength
 - Pol.(H) = Horizontal
 - Pol.(V) = Vertical
 - Amp. = Amplifier Gain
 - Margin = Limit – F/S
 - F/S = Level + AF + CL – Amp.
 - A : Angle
 - H : Height

Above 1 GHz (3 m method)

Temperature : 19.9

Humidity : 31.0 %R.H.

Atmospheric Pressure : 100.3 kPa

Test Date : September 30, 2011

-USB Mode

Freq. (MHz)	Level (dB μ V)	Pol. (H/V)	A ($^{\circ}$)	H (m)	AF (dB)	CL (dB)	Amp. (dB)	F/S (dB μ V/m)	Limit (dB μ V/m)	Margin (dB)
Peak Detector										
1330.42	57.70	V	146.2	2.00	25.02	3.98	43.65	43.04	74.00	30.96
1348.54	56.40	V	146.2	2.00	25.08	4.01	43.66	41.83	74.00	32.17
Average Detector										
1330.42	38.40	V	146.2	2.00	25.02	3.98	43.65	23.74	54.00	30.26
1348.54	39.20	V	146.2	2.00	25.08	4.01	43.66	24.63	54.00	29.37

-HDMI Mode

Freq. (MHz)	Level (dB μ V)	Pol. (H/V)	A ($^{\circ}$)	H (m)	AF (dB)	CL (dB)	Amp. (dB)	F/S (dB μ V/m)	Limit (dB μ V/m)	Margin (dB)
Peak Detector										
1344.58	58.20	V	115.9	1.00	25.07	4.00	43.66	43.61	74.00	30.39
1991.46	53.40	V	42.7	2.00	27.50	5.00	43.74	42.16	74.00	31.84
Average Detector										
1344.58	40.30	V	115.9	1.00	25.07	4.00	43.66	25.71	54.00	28.29
1991.46	37.20	V	42.7	2.00	27.50	5.00	43.74	25.96	54.00	28.04

Measurement Uncertainty (Horizontal) : \pm 4.89 dB (The confidential level is about 95%, K=2)

Measurement Uncertainty (Vertical) : \pm 4.93 dB (The confidential level is about 95%, K=2)

Note: • AF = Antenna Factor • CL = Cable Loss • F/S = Field Strength
 • Pol.(H) = Horizontal • Pol.(V) = Vertical • Amp. = Amplifier Gain
 • Margin = Limit – F/S • F/S = Level + AF + CL – Amp.
 • A : Angle • H : Height

See Appendix B (Radiated Emission)

Appendix A : Conducted Emission

-USB Mode

Neutral

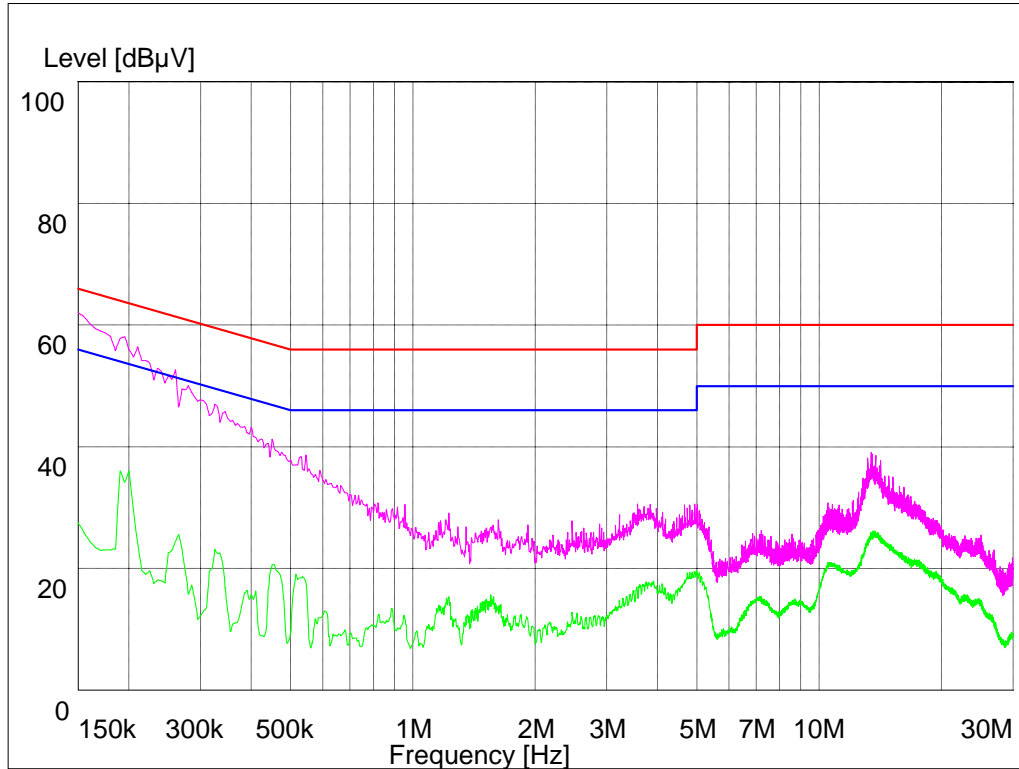

Hot

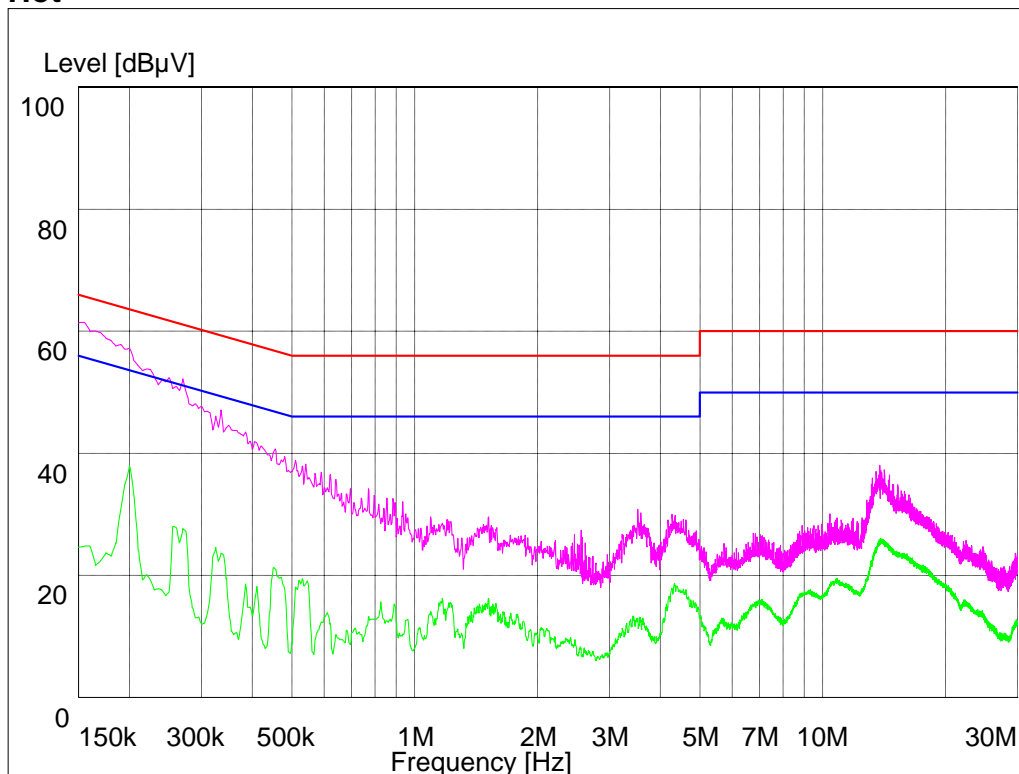

-HDMI Mode

Neutral

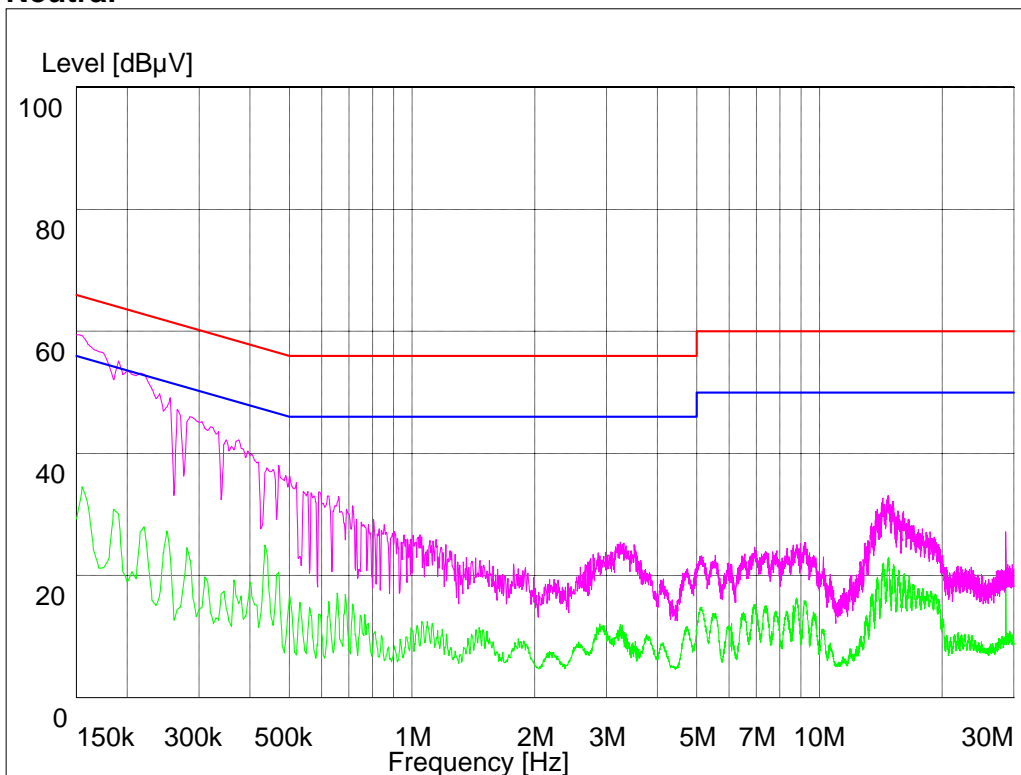

Hot

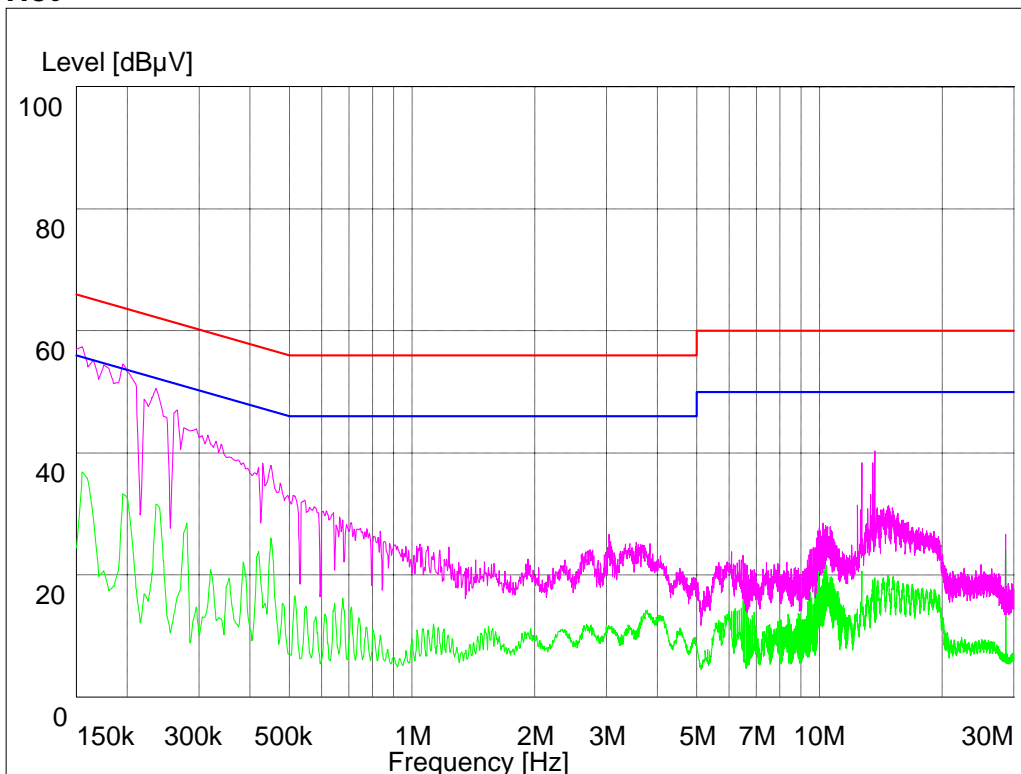

Appendix B : Radiated Emission Below 1 GHz

-USB Mode

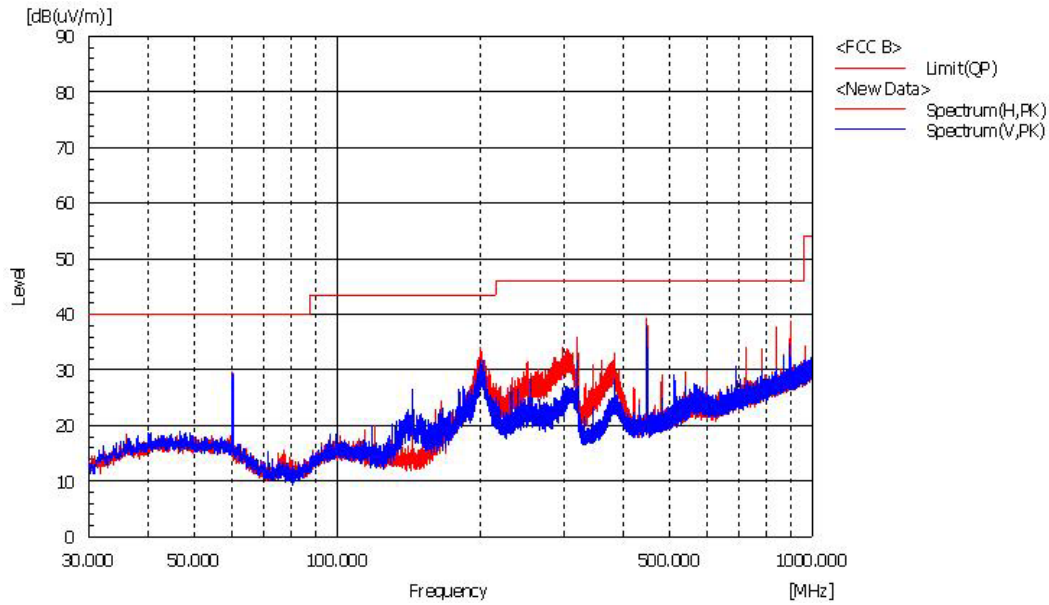

-HDMI Mode

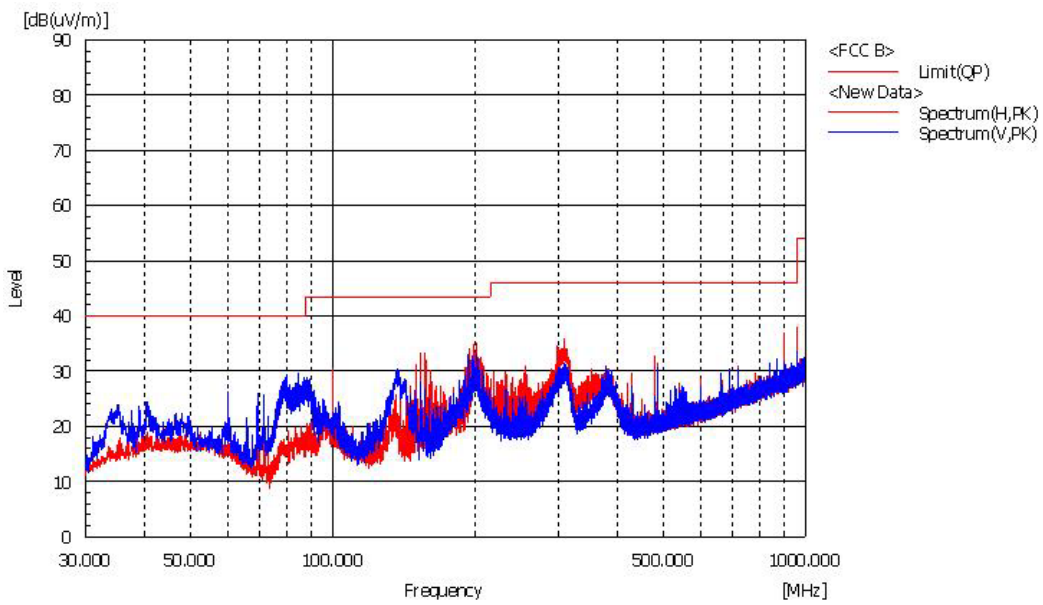

Above 1 GHz

-USB Mode

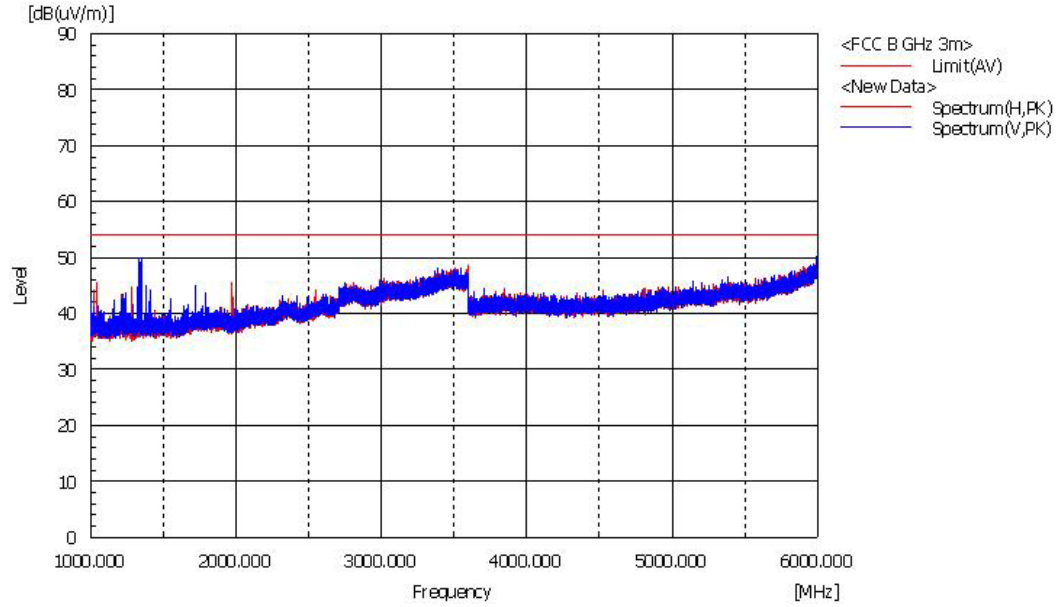

-HDMI Mode

