

W-CDMA Band V

Frequency: 836.6 MHz; Duty Cycle: 1:1; Room Ambient Temperature: 24.0°C; Liquid Temperature: 23.0°C
 Medium parameters used (interpolated): $f = 836.6$ MHz; $\sigma = 0.892$ mho/m; $\epsilon_r = 42.4$; $\rho = 1000$ kg/m³;

DASY4 Configuration:

- Area Scan setting - Find Secondary Maximum Within: 2.0 dB and with a peak SAR value greater than 0.0012W/kg
- Electronics: DAE3 Sn427; Calibrated: 1/17/2012
- Probe: EX3DV4 - SN3749; ConvF(8.68, 8.68, 8.68); Calibrated: 1/27/2012
- Sensor-Surface: 2.5mm (Mechanical Surface Detection)
- Phantom: SAM A (Twin); Type: SAM A; Serial: 1050

Left Touch/Rel.99/Ch4183/Area Scan (7x11x1): Measurement grid: dx=15mm, dy=15mm

[Info: Interpolated medium parameters used for SAR evaluation.](#)

Maximum value of SAR (measured) = 0.174 mW/g

Left Touch/Rel.99/Ch4183/Zoom Scan (5x5x7)/Cube 0: Measurement grid: dx=8mm, dy=8mm, dz=5mm

Reference Value = 14.2 V/m; Power Drift = -0.022 dB

Peak SAR (extrapolated) = 0.196 W/kg

SAR(1 g) = 0.162 mW/g; SAR(10 g) = 0.124 mW/g

[Info: Interpolated medium parameters used for SAR evaluation.](#)

Maximum value of SAR (measured) = 0.178 mW/g

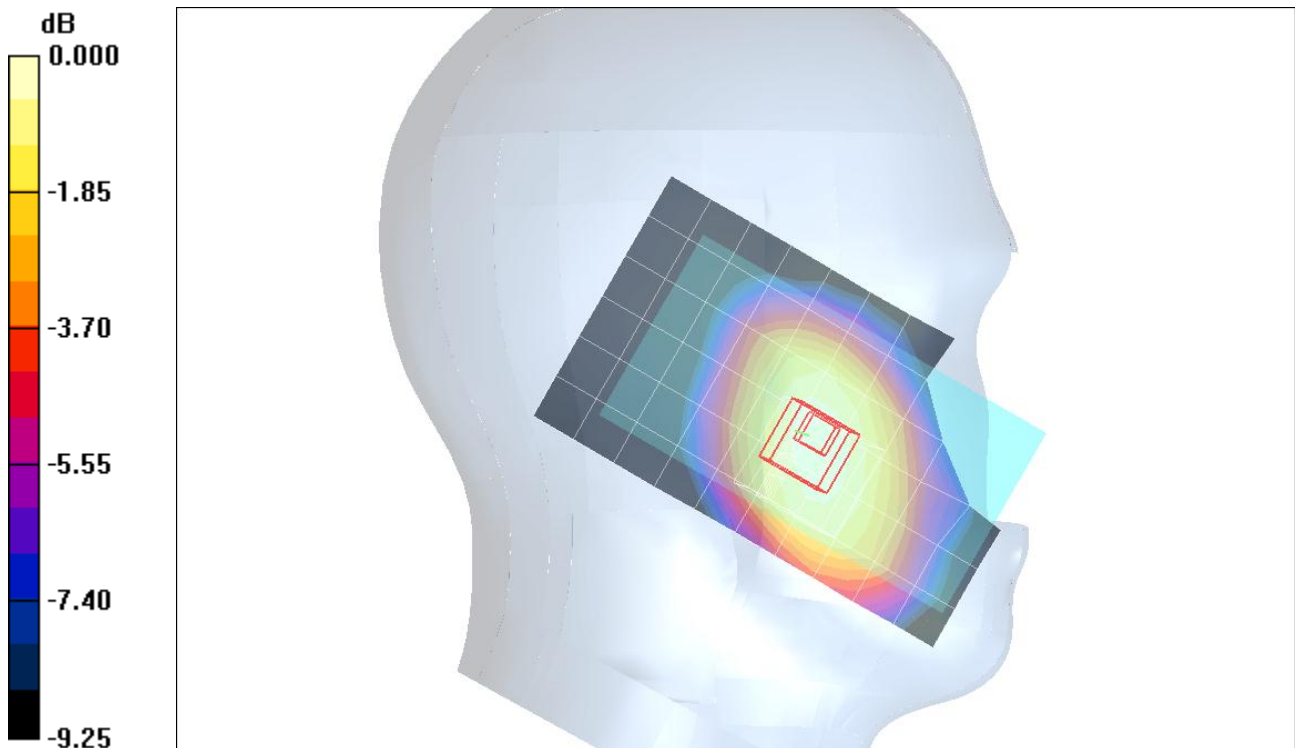

0 dB = 0.178mW/g

W-CDMA Band V

Frequency: 836.6 MHz; Duty Cycle: 1:1

Left Touch/Rel.99/Ch4183/Z Scan (1x1x21): Measurement grid: dx=20mm, dy=20mm, dz=5mm

Info: [Interpolated medium parameters used for SAR evaluation.](#)

Maximum value of SAR (measured) = 0.175 mW/g

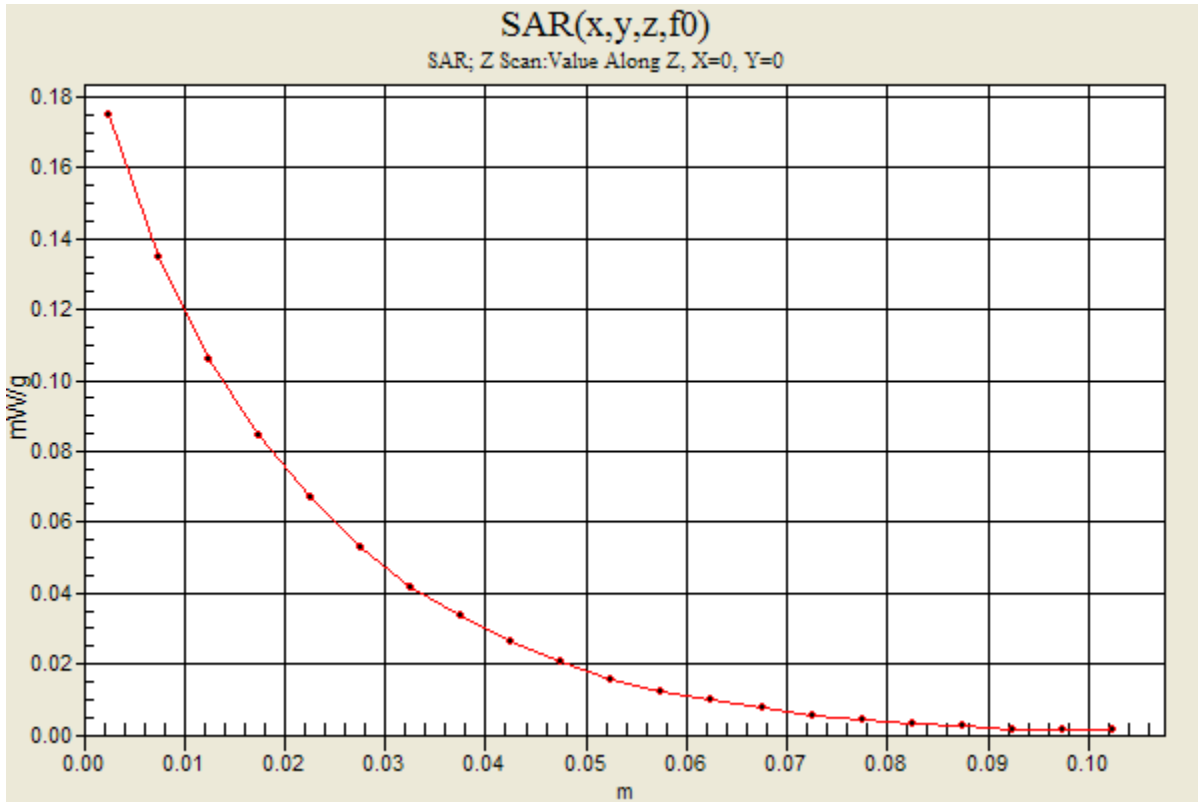

W-CDMA Band V

Frequency: 836.6 MHz; Duty Cycle: 1:1; Room Ambient Temperature: 24.0°C; Liquid Temperature: 23.0°C
 Medium parameters used (interpolated): $f = 836.6 \text{ MHz}$; $\sigma = 0.892 \text{ mho/m}$; $\epsilon_r = 42.4$; $\rho = 1000 \text{ kg/m}^3$;

DASY4 Configuration:

- Area Scan setting - Find Secondary Maximum Within: 2.0 dB and with a peak SAR value greater than 0.0012W/kg
- Electronics: DAE3 Sn427; Calibrated: 1/17/2012
- Probe: EX3DV4 - SN3749; ConvF(8.68, 8.68, 8.68); Calibrated: 1/27/2012
- Sensor-Surface: 2.5mm (Mechanical Surface Detection (Locations From Previous Scan Used))Sensor-Surface: 2.5mm (Mechanical Surface Detection)
- Phantom: SAM A (Twin); Type: SAM A; Serial: 1050

Left Tilt/Rel.99/Ch4183/Area Scan (7x11x1): Measurement grid: dx=15mm, dy=15mm

[Info: Interpolated medium parameters used for SAR evaluation.](#)

Maximum value of SAR (measured) = 0.114 mW/g

Left Tilt/Rel.99/Ch4183/Zoom Scan (5x5x7)/Cube 0: Measurement grid: dx=8mm, dy=8mm, dz=5mm

Reference Value = 11.5 V/m; Power Drift = 0.026 dB

Peak SAR (extrapolated) = 0.121 W/kg

SAR(1 g) = 0.102 mW/g; SAR(10 g) = 0.080 mW/g

[Info: Interpolated medium parameters used for SAR evaluation.](#)

Maximum value of SAR (measured) = 0.110 mW/g

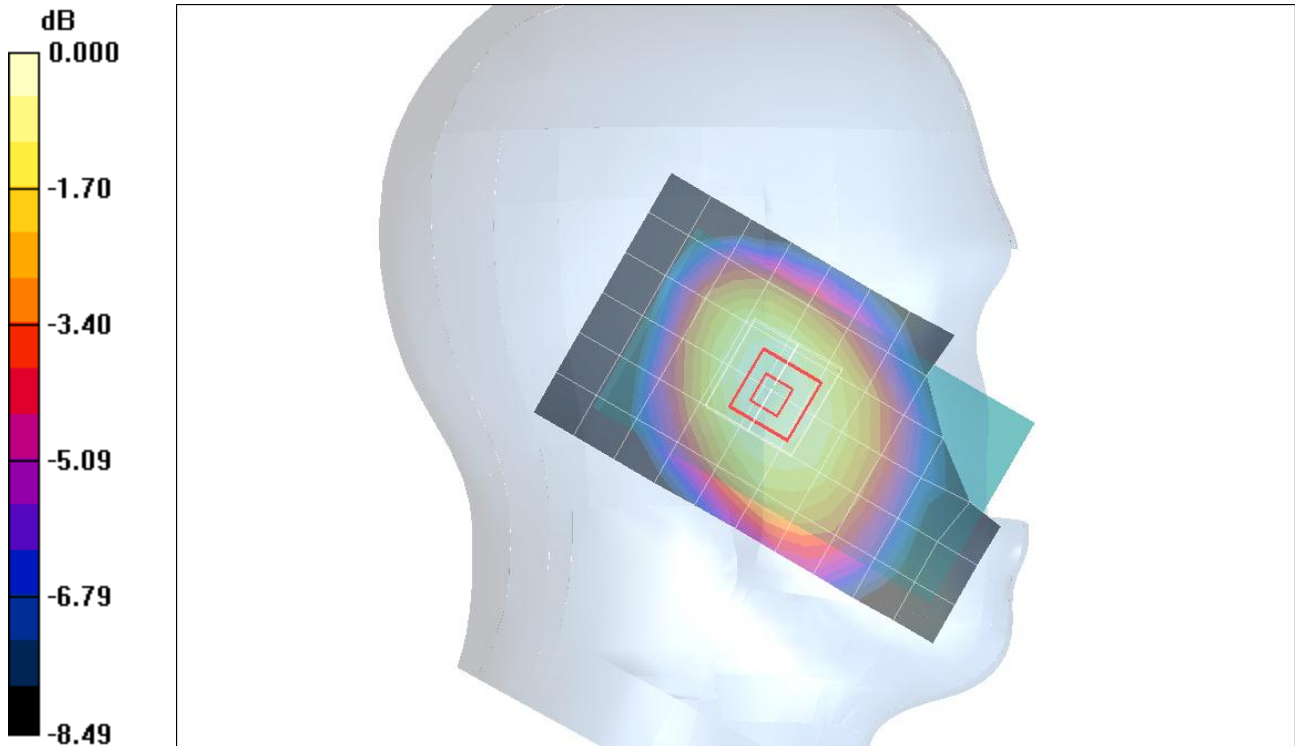

0 dB = 0.110mW/g

W-CDMA Band V

Frequency: 836.6 MHz; Duty Cycle: 1:1; Room Ambient Temperature: 24.0°C; Liquid Temperature: 23.0°C
 Medium parameters used (interpolated): $f = 836.6 \text{ MHz}$; $\sigma = 0.892 \text{ mho/m}$; $\epsilon_r = 42.4$; $\rho = 1000 \text{ kg/m}^3$;

DASY4 Configuration:

- Area Scan setting - Find Secondary Maximum Within: 2.0 dB and with a peak SAR value greater than 0.0012W/kg
- Electronics: DAE3 Sn427; Calibrated: 1/17/2012
- Probe: EX3DV4 - SN3749; ConvF(8.68, 8.68, 8.68); Calibrated: 1/27/2012
- Sensor-Surface: 2.5mm (Mechanical Surface Detection)
- Phantom: SAM A (Twin); Type: SAM A; Serial: 1050

Right Touch/Rel.99/Ch4183/Area Scan (7x11x1): Measurement grid: dx=15mm, dy=15mm

[Info: Interpolated medium parameters used for SAR evaluation.](#)

Maximum value of SAR (measured) = 0.152 mW/g

Right Touch/Rel.99/Ch4183/Zoom Scan (5x5x7)/Cube 0: Measurement grid: dx=8mm, dy=8mm, dz=5mm

Reference Value = 13.2 V/m; Power Drift = 0.012 dB

Peak SAR (extrapolated) = 0.172 W/kg

SAR(1 g) = 0.143 mW/g; SAR(10 g) = 0.110 mW/g

[Info: Interpolated medium parameters used for SAR evaluation.](#)

Maximum value of SAR (measured) = 0.160 mW/g

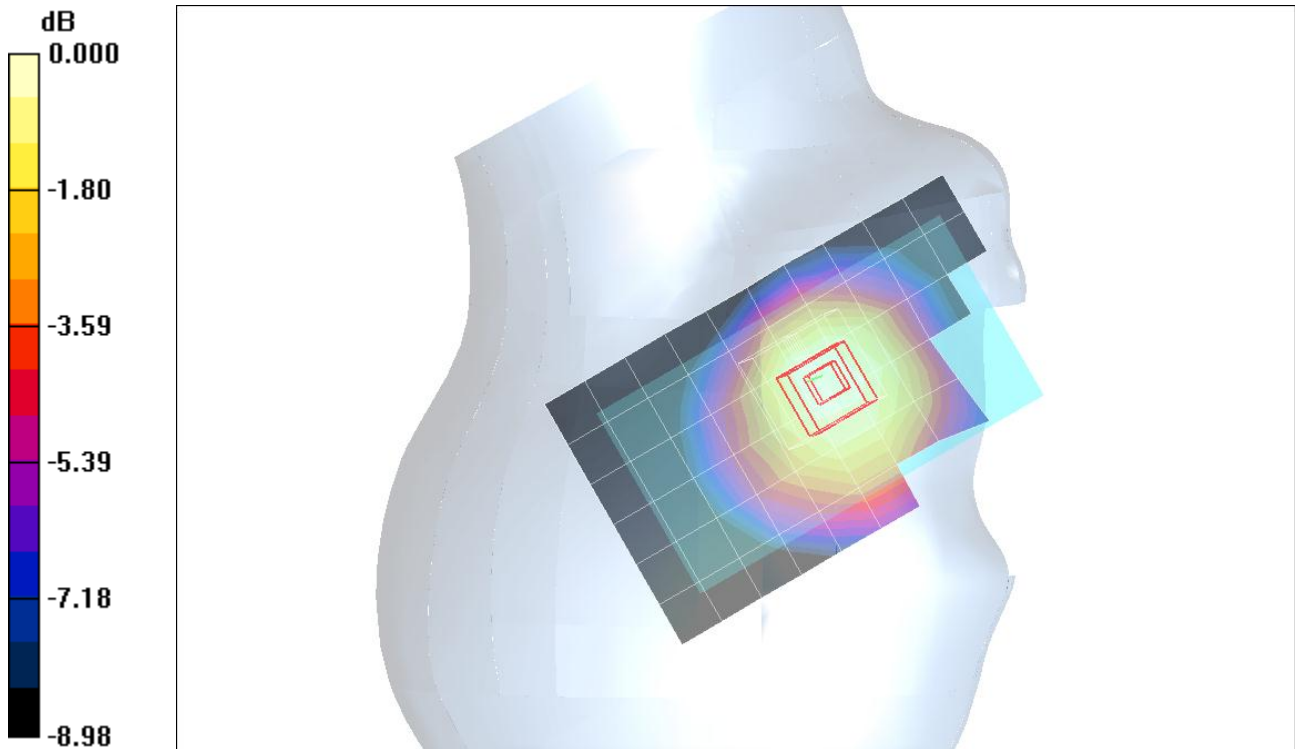

0 dB = 0.160mW/g

W-CDMA Band V

Frequency: 836.6 MHz; Duty Cycle: 1:1; Room Ambient Temperature: 24.0°C; Liquid Temperature: 23.0°C
 Medium parameters used (interpolated): $f = 836.6 \text{ MHz}$; $\sigma = 0.892 \text{ mho/m}$; $\epsilon_r = 42.4$; $\rho = 1000 \text{ kg/m}^3$;

DASY4 Configuration:

- Area Scan setting - Find Secondary Maximum Within: 2.0 dB and with a peak SAR value greater than 0.0012W/kg
- Electronics: DAE3 Sn427; Calibrated: 1/17/2012
- Probe: EX3DV4 - SN3749; ConvF(8.68, 8.68, 8.68); Calibrated: 1/27/2012
- Sensor-Surface: 2.5mm (Mechanical Surface Detection)
- Phantom: SAM A (Twin); Type: SAM A; Serial: 1050

Right Tilt/Rel.99/Ch4183/Area Scan (7x11x1): Measurement grid: $dx=15\text{mm}$, $dy=15\text{mm}$

[Info: Interpolated medium parameters used for SAR evaluation.](#)

Maximum value of SAR (measured) = 0.104 mW/g

Right Tilt/Rel.99/Ch4183/Zoom Scan (5x5x7)/Cube 0: Measurement grid: $dx=8\text{mm}$, $dy=8\text{mm}$, $dz=5\text{mm}$

Reference Value = 11.0 V/m; Power Drift = 0.013 dB

Peak SAR (extrapolated) = 0.115 W/kg

SAR(1 g) = 0.097 mW/g; SAR(10 g) = 0.076 mW/g

[Info: Interpolated medium parameters used for SAR evaluation.](#)

Maximum value of SAR (measured) = 0.107 mW/g

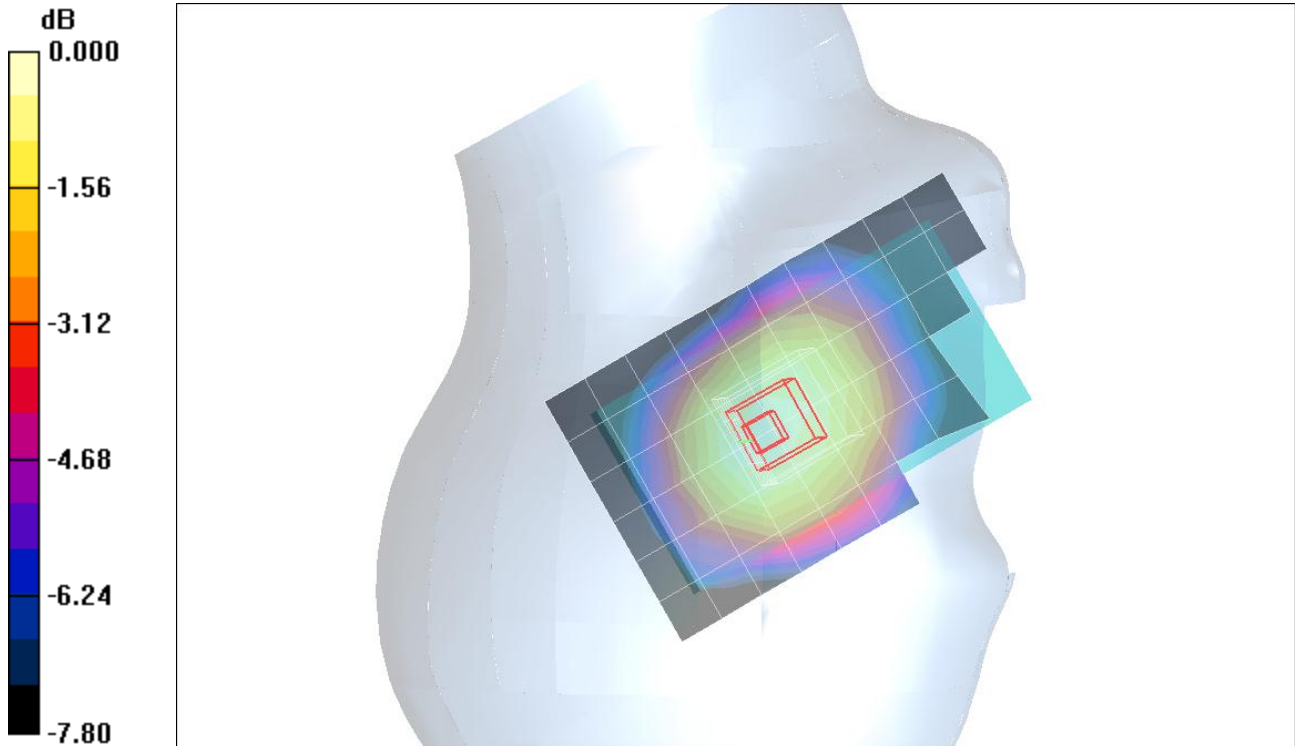

0 dB = 0.107mW/g

W-CDMA Band V

Frequency: 836.6 MHz; Duty Cycle: 1:1; Room Ambient Temperature: 24.0°C; Liquid Temperature: 23.0°C
 Medium parameters used (interpolated): $f = 836.6 \text{ MHz}$; $\sigma = 0.984 \text{ mho/m}$; $\epsilon_r = 53.3$; $\rho = 1000 \text{ kg/m}^3$;

DASY4 Configuration:

- Area Scan setting - Find Secondary Maximum Within: 2.0 dB and with a peak SAR value greater than 0.0012W/kg
- Electronics: DAE3 Sn427; Calibrated: 1/17/2012
- Probe: EX3DV4 - SN3749; ConvF(8.84, 8.84, 8.84); Calibrated: 1/27/2012
- Sensor-Surface: 2.5mm (Mechanical Surface Detection)
- Phantom: SAM B (Twin); Type: SAM B; Serial: TP-105

Rear/Rel.99/Ch4183/Area Scan (8x13x1): Measurement grid: dx=15mm, dy=15mm

[Info: Interpolated medium parameters used for SAR evaluation.](#)

Maximum value of SAR (measured) = 0.545 mW/g

Rear/Rel.99/Ch4183/Zoom Scan (5x5x7)/Cube 0: Measurement grid: dx=8mm, dy=8mm, dz=5mm

Reference Value = 24.0 V/m; Power Drift = 0.022 dB

Peak SAR (extrapolated) = 0.618 W/kg

SAR(1 g) = 0.485 mW/g; SAR(10 g) = 0.366 mW/g

[Info: Interpolated medium parameters used for SAR evaluation.](#)

Maximum value of SAR (measured) = 0.546 mW/g

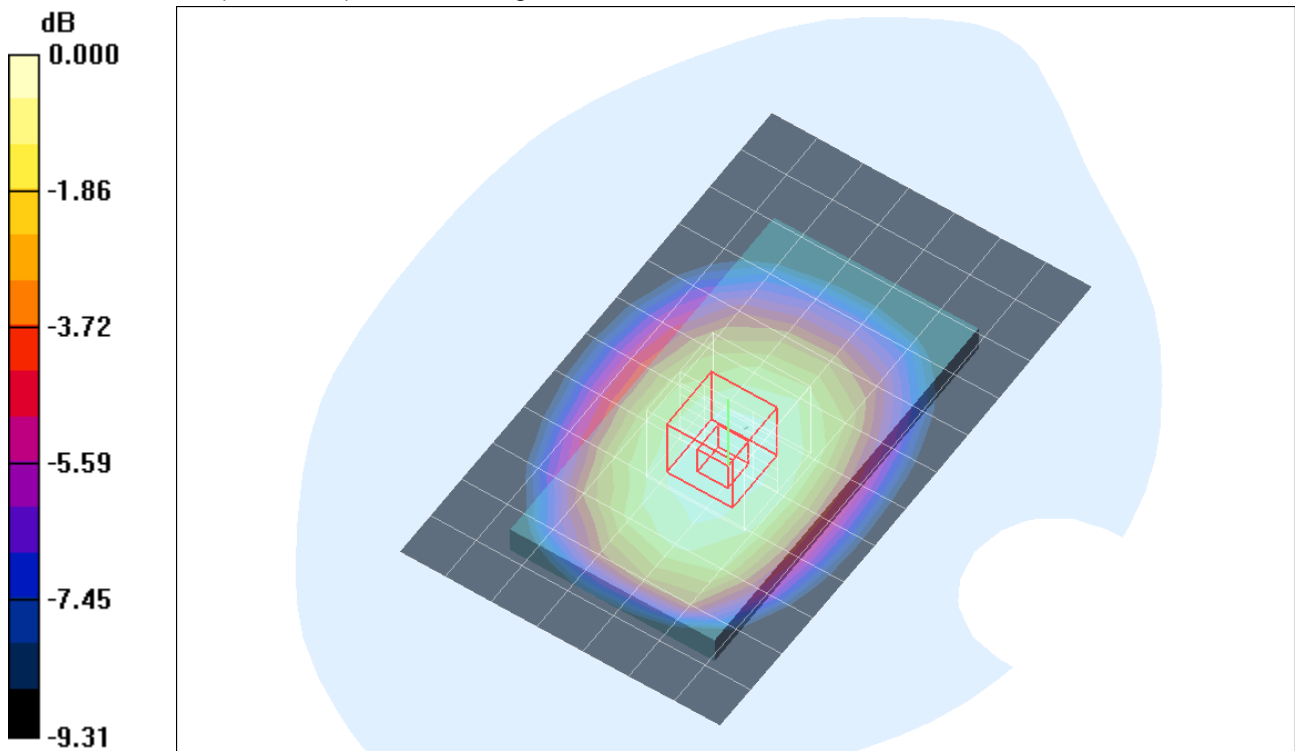

0 dB = 0.546mW/g

W-CDMA Band V

Frequency: 836.6 MHz; Duty Cycle: 1:1

Rear/Rel.99/Ch4183/Z Scan (1x1x21): Measurement grid: dx=20mm, dy=20mm, dz=5mm

Info: [Interpolated medium parameters used for SAR evaluation.](#)

Maximum value of SAR (measured) = 0.544 mW/g

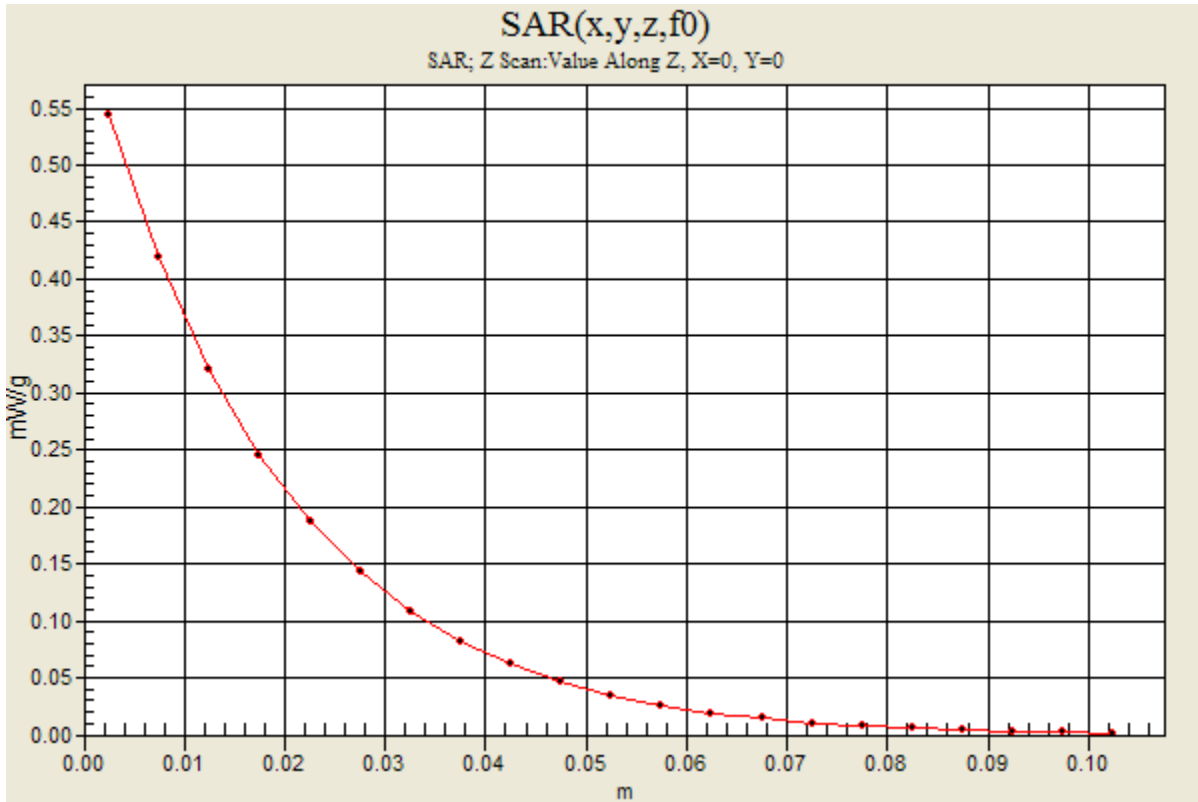

W-CDMA Band V

Frequency: 836.6 MHz; Duty Cycle: 1:1; Room Ambient Temperature: 24.0°C; Liquid Temperature: 23.0°C
 Medium parameters used (interpolated): $f = 836.6 \text{ MHz}$; $\sigma = 0.984 \text{ mho/m}$; $\epsilon_r = 53.3$; $\rho = 1000 \text{ kg/m}^3$;

DASY4 Configuration:

- Area Scan setting - Find Secondary Maximum Within: 2.0 dB and with a peak SAR value greater than 0.0012W/kg
- Electronics: DAE3 Sn427; Calibrated: 1/17/2012
- Probe: EX3DV4 - SN3749; ConvF(8.84, 8.84, 8.84); Calibrated: 1/27/2012
- Sensor-Surface: 2.5mm (Mechanical Surface Detection (Locations From Previous Scan Used))Sensor-Surface: 2.5mm (Mechanical Surface Detection)
- Phantom: SAM B (Twin); Type: SAM B; Serial: TP-105

Rear with Headset/Rel.99/Ch4183/Area Scan (8x13x1): Measurement grid: dx=15mm, dy=15mm

[Info: Interpolated medium parameters used for SAR evaluation.](#)

Maximum value of SAR (measured) = 0.425 mW/g

Rear with Headset/Rel.99/Ch4183/Zoom Scan (5x5x7)/Cube 0: Measurement grid: dx=8mm,

dy=8mm, dz=5mm

Reference Value = 21.3 V/m; Power Drift = 0.007 dB

Peak SAR (extrapolated) = 0.494 W/kg

SAR(1 g) = 0.376 mW/g; SAR(10 g) = 0.280 mW/g

[Info: Interpolated medium parameters used for SAR evaluation.](#)

Maximum value of SAR (measured) = 0.428 mW/g

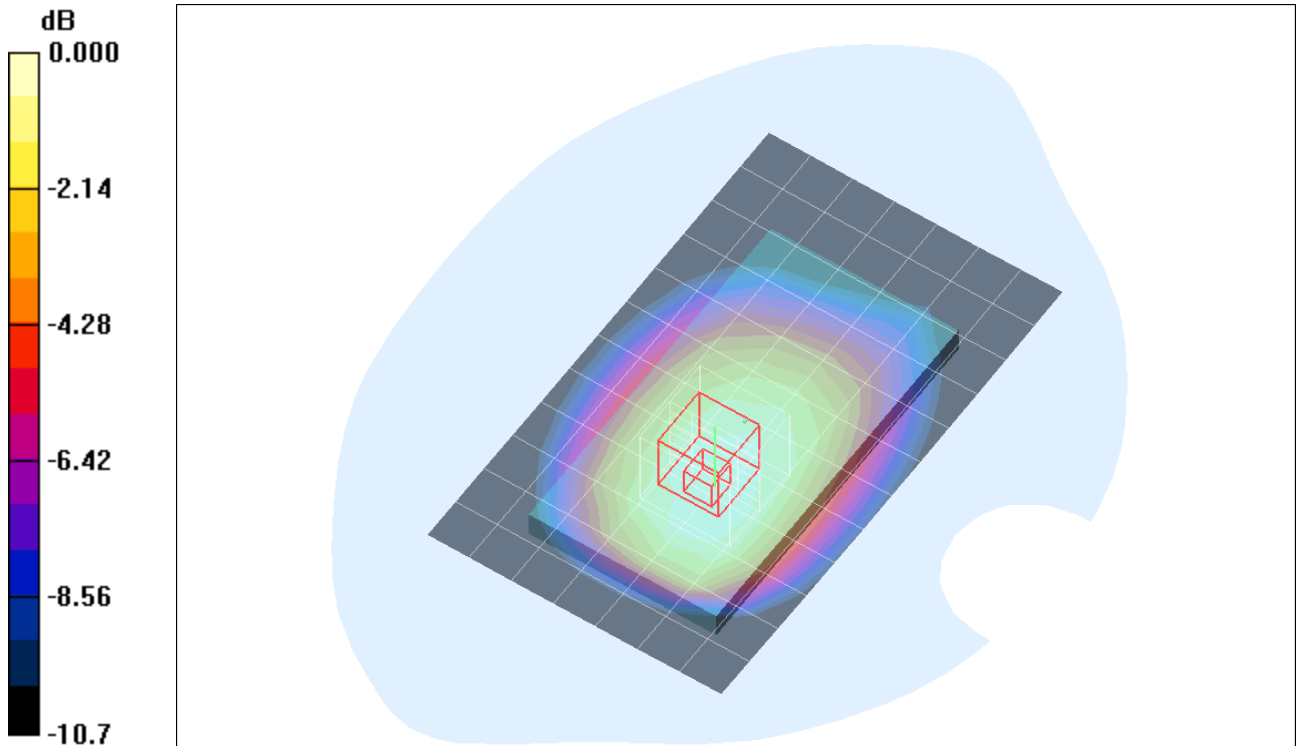

0 dB = 0.428mW/g

W-CDMA Band V

Frequency: 836.6 MHz; Duty Cycle: 1:1; Room Ambient Temperature: 24.0°C; Liquid Temperature: 23.0°C
 Medium parameters used (interpolated): $f = 836.6 \text{ MHz}$; $\sigma = 0.984 \text{ mho/m}$; $\epsilon_r = 53.3$; $\rho = 1000 \text{ kg/m}^3$;

DASY4 Configuration:

- Area Scan setting - Find Secondary Maximum Within: 2.0 dB and with a peak SAR value greater than 0.0012W/kg
- Electronics: DAE3 Sn427; Calibrated: 1/17/2012
- Probe: EX3DV4 - SN3749; ConvF(8.84, 8.84, 8.84); Calibrated: 1/27/2012
- Sensor-Surface: 2.5mm (Mechanical Surface Detection)
- Phantom: SAM B (Twin); Type: SAM B; Serial: TP-105

Front/Rel.99/Ch4183/Area Scan (8x13x1): Measurement grid: dx=15mm, dy=15mm

[Info: Interpolated medium parameters used for SAR evaluation.](#)

Maximum value of SAR (measured) = 0.215 mW/g

Front/Rel.99/Ch4183/Zoom Scan (5x5x7)/Cube 0: Measurement grid: dx=8mm, dy=8mm, dz=5mm

Reference Value = 15.0 V/m; Power Drift = 0.050 dB

Peak SAR (extrapolated) = 0.241 W/kg

SAR(1 g) = 0.198 mW/g; SAR(10 g) = 0.153 mW/g

[Info: Interpolated medium parameters used for SAR evaluation.](#)

Maximum value of SAR (measured) = 0.219 mW/g

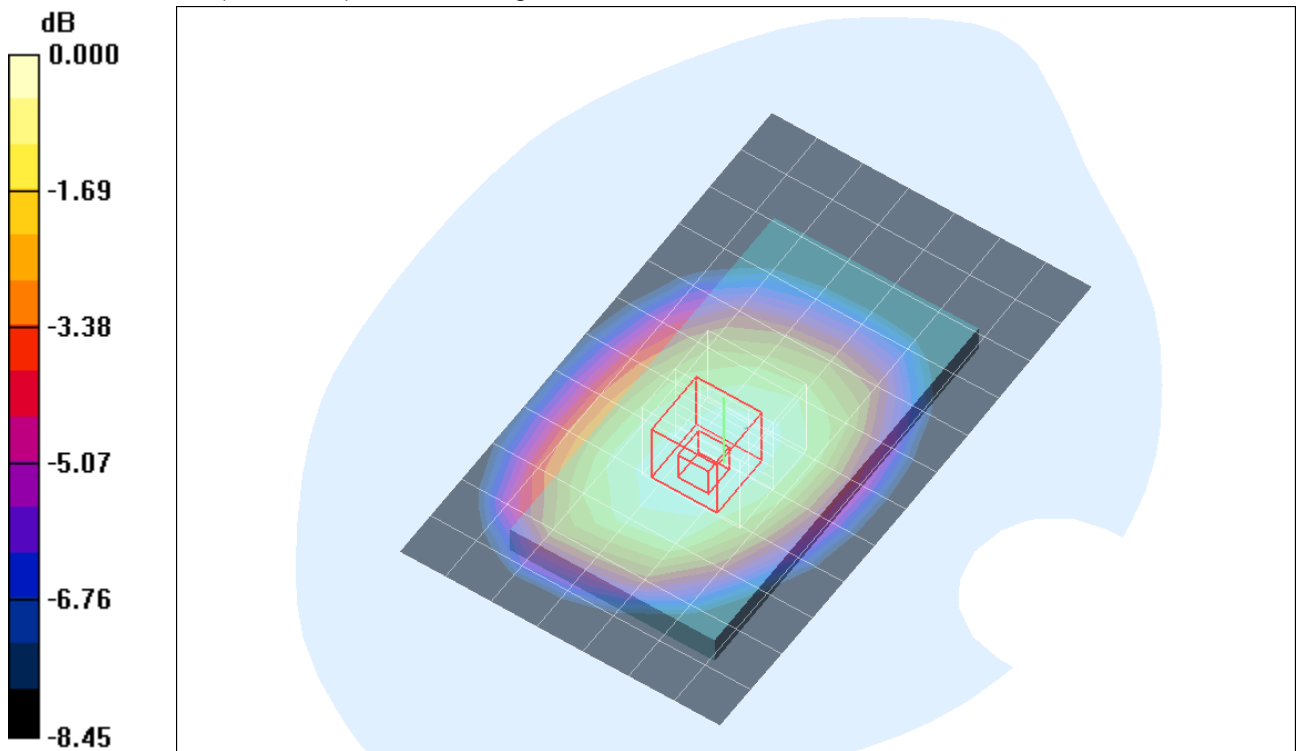

0 dB = 0.219mW/g

W-CDMA Band V

Frequency: 836.6 MHz; Duty Cycle: 1:1; Room Ambient Temperature: 24.0°C; Liquid Temperature: 23.0°C
 Medium parameters used (interpolated): $f = 836.6 \text{ MHz}$; $\sigma = 0.984 \text{ mho/m}$; $\epsilon_r = 53.3$; $\rho = 1000 \text{ kg/m}^3$;

DASY4 Configuration:

- Area Scan setting - Find Secondary Maximum Within: 2.0 dB and with a peak SAR value greater than 0.0012W/kg
- Electronics: DAE3 Sn427; Calibrated: 1/17/2012
- Probe: EX3DV4 - SN3749; ConvF(8.84, 8.84, 8.84); Calibrated: 1/27/2012
- Sensor-Surface: 2.5mm (Mechanical Surface Detection)
- Phantom: SAM B (Twin); Type: SAM B; Serial: TP-105

Edge2/Rel.99/Ch4183/Area Scan (7x13x1): Measurement grid: dx=15mm, dy=15mm

[Info: Interpolated medium parameters used for SAR evaluation.](#)

Maximum value of SAR (measured) = 0.222 mW/g

Edge2/Rel.99/Ch4183/Zoom Scan (5x5x7)/Cube 0: Measurement grid: dx=8mm, dy=8mm, dz=5mm

Reference Value = 15.3 V/m; Power Drift = 0.112 dB

Peak SAR (extrapolated) = 0.270 W/kg

SAR(1 g) = 0.194 mW/g; SAR(10 g) = 0.134 mW/g

[Info: Interpolated medium parameters used for SAR evaluation.](#)

Maximum value of SAR (measured) = 0.230 mW/g

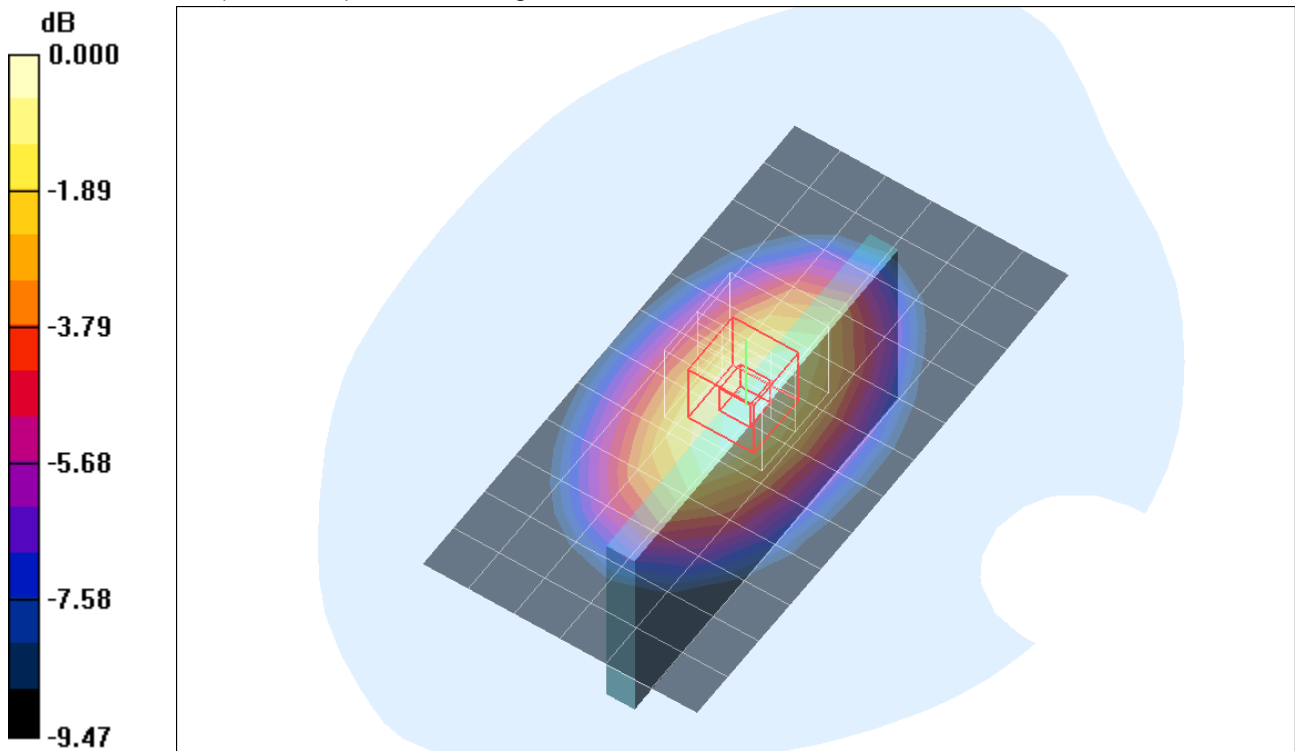

0 dB = 0.230mW/g

W-CDMA Band V

Frequency: 836.6 MHz; Duty Cycle: 1:1; Room Ambient Temperature: 24.0°C; Liquid Temperature: 23.0°C
 Medium parameters used (interpolated): $f = 836.6$ MHz; $\sigma = 0.984$ mho/m; $\epsilon_r = 53.3$; $\rho = 1000$ kg/m³ ;

DASY4 Configuration:

- Area Scan setting - Find Secondary Maximum Within: 2.0 dB and with a peak SAR value greater than 0.0012W/kg
- Electronics: DAE3 Sn427; Calibrated: 1/17/2012
- Probe: EX3DV4 - SN3749; ConvF(8.84, 8.84, 8.84); Calibrated: 1/27/2012
- Sensor-Surface: 2.5mm (Mechanical Surface Detection)
- Phantom: SAM B (Twin); Type: SAM B; Serial: TP-105

Edge3/Rel.99/Ch4183/Area Scan (6x8x1): Measurement grid: dx=15mm, dy=15mm

[Info: Interpolated medium parameters used for SAR evaluation.](#)

Maximum value of SAR (measured) = 0.078 mW/g

Edge3/Rel.99/Ch4183/Zoom Scan (5x5x7)/Cube 0: Measurement grid: dx=8mm, dy=8mm, dz=5mm

Reference Value = 9.08 V/m; Power Drift = 0.127 dB

Peak SAR (extrapolated) = 0.118 W/kg

SAR(1 g) = 0.074 mW/g; SAR(10 g) = 0.046 mW/g

[Info: Interpolated medium parameters used for SAR evaluation.](#)

Maximum value of SAR (measured) = 0.092 mW/g

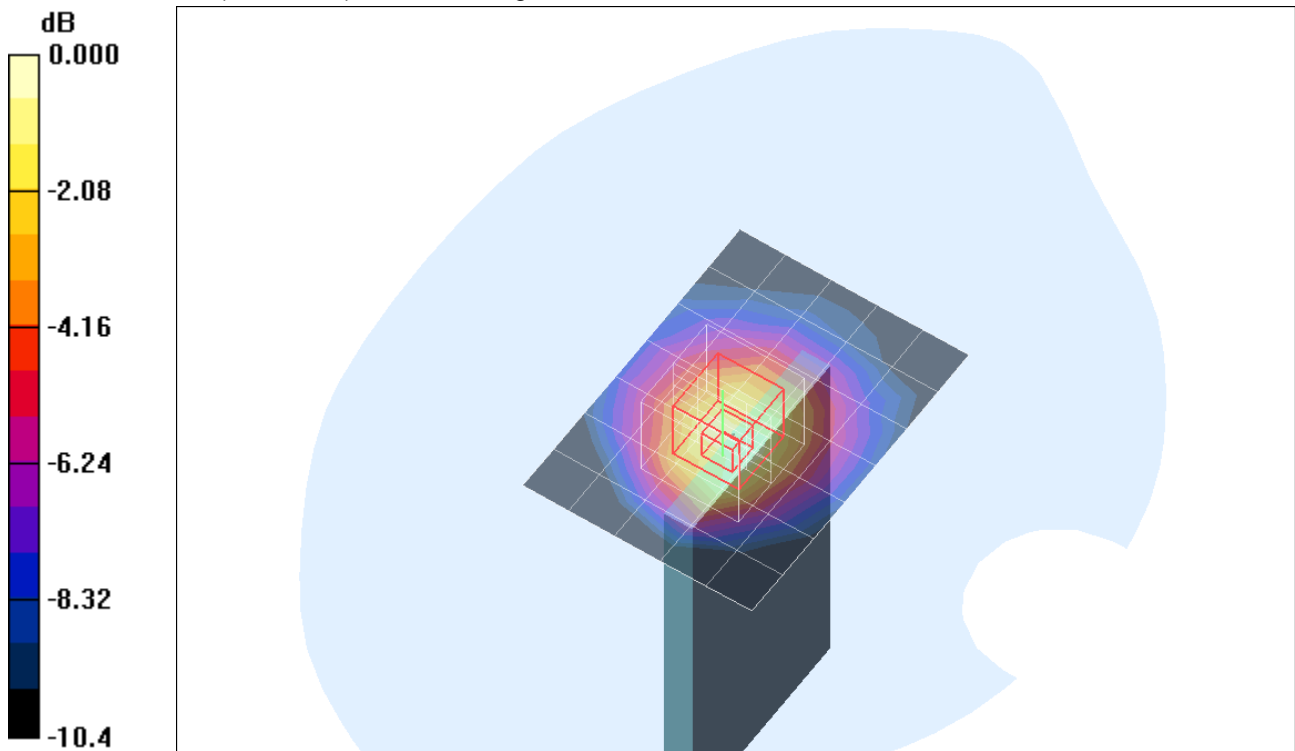

0 dB = 0.092mW/g

W-CDMA Band V

Frequency: 836.6 MHz; Duty Cycle: 1:1; Room Ambient Temperature: 24.0°C; Liquid Temperature: 23.0°C
 Medium parameters used (interpolated): $f = 836.6 \text{ MHz}$; $\sigma = 0.984 \text{ mho/m}$; $\epsilon_r = 53.3$; $\rho = 1000 \text{ kg/m}^3$;

DASY4 Configuration:

- Area Scan setting - Find Secondary Maximum Within: 2.0 dB and with a peak SAR value greater than 0.0012W/kg
- Electronics: DAE3 Sn427; Calibrated: 1/17/2012
- Probe: EX3DV4 - SN3749; ConvF(8.84, 8.84, 8.84); Calibrated: 1/27/2012
- Sensor-Surface: 2.5mm (Mechanical Surface Detection)
- Phantom: SAM B (Twin); Type: SAM B; Serial: TP-105

Edge4/Rel.99/Ch4183/Area Scan (7x13x1): Measurement grid: dx=15mm, dy=15mm

[Info: Interpolated medium parameters used for SAR evaluation.](#)

Maximum value of SAR (measured) = 0.288 mW/g

Edge4/Rel.99/Ch4183/Zoom Scan (5x5x7)/Cube 0: Measurement grid: dx=8mm, dy=8mm, dz=5mm

Reference Value = 17.4 V/m; Power Drift = 0.085 dB

Peak SAR (extrapolated) = 0.354 W/kg

SAR(1 g) = 0.253 mW/g; SAR(10 g) = 0.174 mW/g

[Info: Interpolated medium parameters used for SAR evaluation.](#)

Maximum value of SAR (measured) = 0.300 mW/g

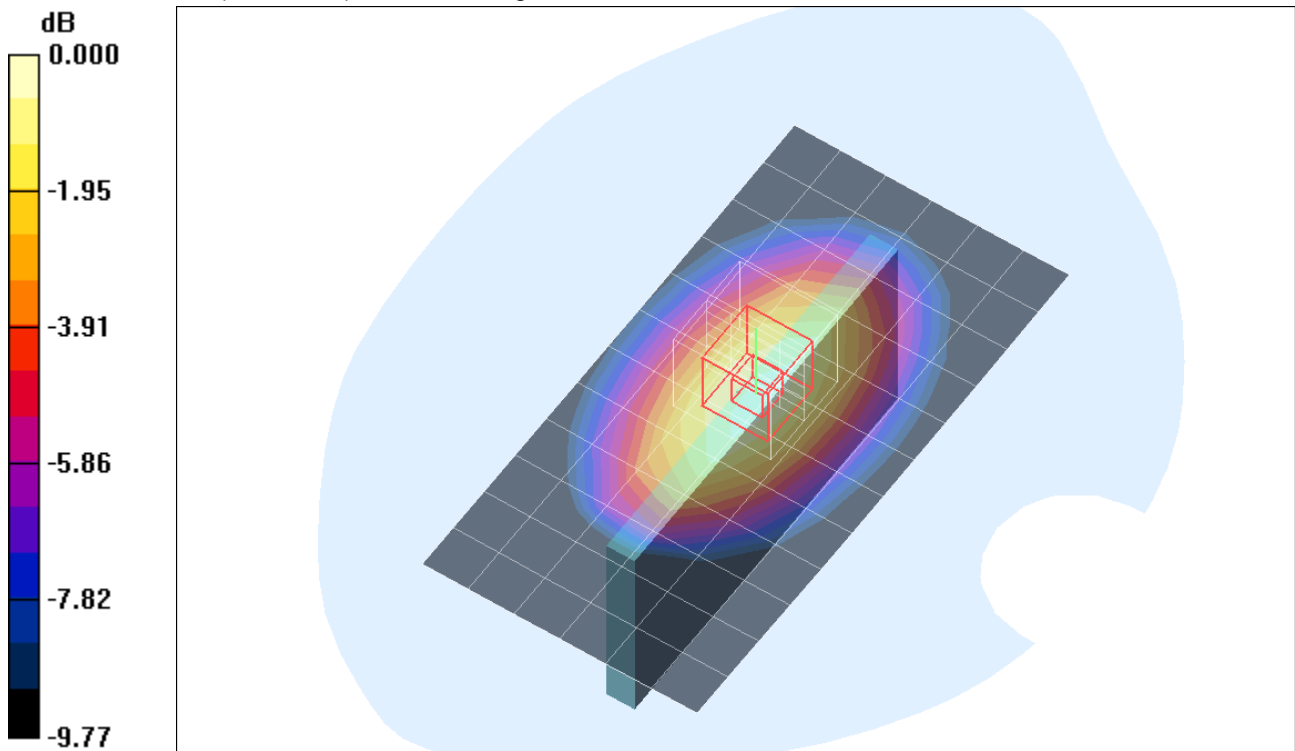

0 dB = 0.300mW/g