

RF TEST REPORT

Test item : Cellular/PCS GSM/GPRS/EDGE and Cellular WCDMA/HSPA
Phone with Bluetooth and WLAN
Model No. : LG-P768f, LG-P768F, LGP768f, LGP768F, P769f, P769F
Order No. : DEMC1207-01175
Date of receipt : 2012-07-13
Test duration : 2012-08-01 ~ 2012-08-31
Date of issue : 2012-09-11
Use of report : Original Grant

Applicant : LG Electronics MobileComm U.S.A., Inc.
1000 Sylvan Avenue, Englewood Cliffs NJ 07632

Test laboratory : Digital EMC Co., Ltd.
683-3, Yubang-Dong, Cheoin-Gu, Yongin-Si, Kyunggi-Do, 449-080, Korea

Test specification : §22(H), §24(E)
Test environment : See appended test report
Test result : Pass Fail

The test results presented in this test report are limited only to the sample supplied by applicant and the use of this test report is inhibited other than its purpose. This test report shall not be reproduced except in full, without the written approval of DIGITAL EMC CO., LTD.

Tested by:



Engineer
S.K.RYU

Witnessed by:

N/A

Reviewed by:



Technical Director
Harvey Sung

Test Report Version

Test Report No.	Date	Description
DRTFCC1209-0474	Sep. 11, 2012	Final version for approval

Table of Contents

1. GENERAL INFORMATION	4
2. INTRODUCTION	5
2.1. EUT DESCRIPTION.....	5
2.2. MEASURING INSTRUMENT CALIBRATION	5
2.3. TEST FACILITY	5
3. DESCRIPTION OF TESTS.....	6
3.1 ERP & EIRP	6
3.2 PEAK TO AVERAGE RATIO	7
3.3 OCCUPIED BANDWIDTH.	8
3.4 SPURIOUS AND HARMONIC EMISSIONS AT ANTENNA TERMINAL.....	9
3.5 RADIATED SPURIOUS EMISSIONS	10
3.6 FREQUENCY STABILITY / VARIATION OF AMBIENT TEMPERATURE	11
4. LIST OF TEST EQUIPMENT.....	12
5. SUMMARY OF TEST RESULTS	13
6. SAMPLE CALCULATION	14
7. TEST DATA	15
7.1 CONDUCTED OUTPUT POWER	15
7.2 PEAK TO AVERAGE RATIO	17
7.3 OCCUPIED BANDWIDTH	17
7.4 SPURIOUS AND HARMONIC EMISSIONS AT ANTENNA TERMINAL.....	17
7.5 BAND EDGE.....	17
7.6 EFFECTIVE RADIATED POWER(GSM850/ WCDMA850/ HSUPA850).....	18
7.7 EQUIVALENT ISOTROPIC RADIATED POWER(GSM1900)	19
7.8 RADIATED SPURIOUS EMISSIONS	20
7.8.1 RADIATED SPURIOUS EMISSIONS (GSM850)	20
7.8.2 RADIATED SPURIOUS EMISSIONS (WCDMA850)	21
7.8.3 RADIATED SPURIOUS EMISSIONS (HSUPA850)	22
7.8.4 RADIATED SPURIOUS EMISSIONS (GSM1900)	23
7.9 FREQUENCY STABILITY / VARIATION OF AMBIENT TEMPERATURE	24
7.9.1 FREQUENCY STABILITY (GSM850)	24
7.9.2 FREQUENCY STABILITY (WCDMA850)	25
7.9.3 FREQUENCY STABILITY (HSUPA850)	26
7.9.4 FREQUENCY STABILITY (GSM1900)	27
8. TEST PLOTS.....	28
8.1 Peak to Average Ratio	28
8.2 Occupied Bandwidth 99 % Bandwidth	29
8.3 Spurious Emissions at Antenna Terminal	41
8.4 Band Edge	56

1. GENERAL INFORMATION

Applicant Name: LG Electronics MobileComm U.S.A., Inc.

Address: 1000 Sylvan Avenue, Englewood Cliffs NJ 07632

FCC ID : ZNFP768F

FCC Classification : Licensed Portable Transmitter Held to Ear (PCE)

EUT Type : Cellular/PCS GSM/GPRS/EDGE and Cellular WCDMA/HSPA Phone with Bluetooth and WLAN

Model Name : LG-P768f

Add Model Name : LG-P768F, LGP768f, LGP768F, P769f, P769F

Supplying power : Standard Battery
 - Type: Li-Ion Battery
 - M/N: BL-53QH
 - Rating: DC 3.8V & 2150mAh 8.2Wh

Antenna Information : Internal Antenna
 - Type: Built-In type

Tx Frequency : GSM850: 824.2 ~ 848.8 MHz
 GSM1900: 1850.2 ~ 1909.8 MHz
 EDGE850: 824.2 ~ 848.8 MHz
 EDGE1900: 1850.2 ~ 1909.8 MHz
 WCDMA850: 826.4 ~ 846.6 MHz
 HSUPA850: 826.4 ~ 846.6 MHz

Rx Frequency : GSM850: 869.2 ~ 893.8 MHz
 GSM1900: 1930.2 ~ 1989.8 MHz
 EDGE850: 869.2 ~ 893.8 MHz
 EDGE1900: 1930.2 ~ 1989.8 MHz
 WCDMA850: 871.4 ~ 891.6 MHz
 HSUPA850: 871.4 ~ 891.6 MHz

Max. RF Output Power : GSM850: 1.371W ERP(31.37dBm)
 GSM1900: 0.910W EIRP(29.59dBm)
 EDGE850: 0.659W ERP(28.19dBm)
 EDGE1900: 0.431W EIRP(26.34dBm)
 WCDMA850: 0.330W ERP(25.19dBm)
 HSUPA 850: 0.309W ERP(24.90dBm)

Emission Designator(s) : GSM850: 244KGXW
 GSM1900: 244KGXW
 EDGE850: 244KG7W
 EDGE1900: 246KG7W
 WCDMA850: 4M06F9W
 HSUPA850: 4M05F9W

2. INTRODUCTION

2.1. EUT DESCRIPTION

The Equipment Under Test(EUT) supports a dual band(Cellular/PCS) with GSM/GPRS/EDGE, a single band(Cellular) with WCDMA/HSPA, Bluetooth, 2.4GHz/5GHz WLAN.

2.2. MEASURING INSTRUMENT CALIBRATION

The measuring equipment, which was utilized in performing the tests documented herein, has been calibrated in accordance with the manufacturer's recommendations for utilizing calibration equipment, which is traceable to recognized national standards.

2.3. TEST FACILITY

The 3&10M test site and conducted measurement facility used to collect the radiated data are located at the 683-3, Yubang-Dong, Yongin-Si, Gyunggi-Do, 449-080, South Korea. The site is constructed in conformance with the requirements.

- 3&10M test site registration Number: 678747

3. DESCRIPTION OF TESTS

3.1 ERP & EIRP

(Effective Radiated Power & Equivalent Isotropic Radiated Power)

Test Set-up

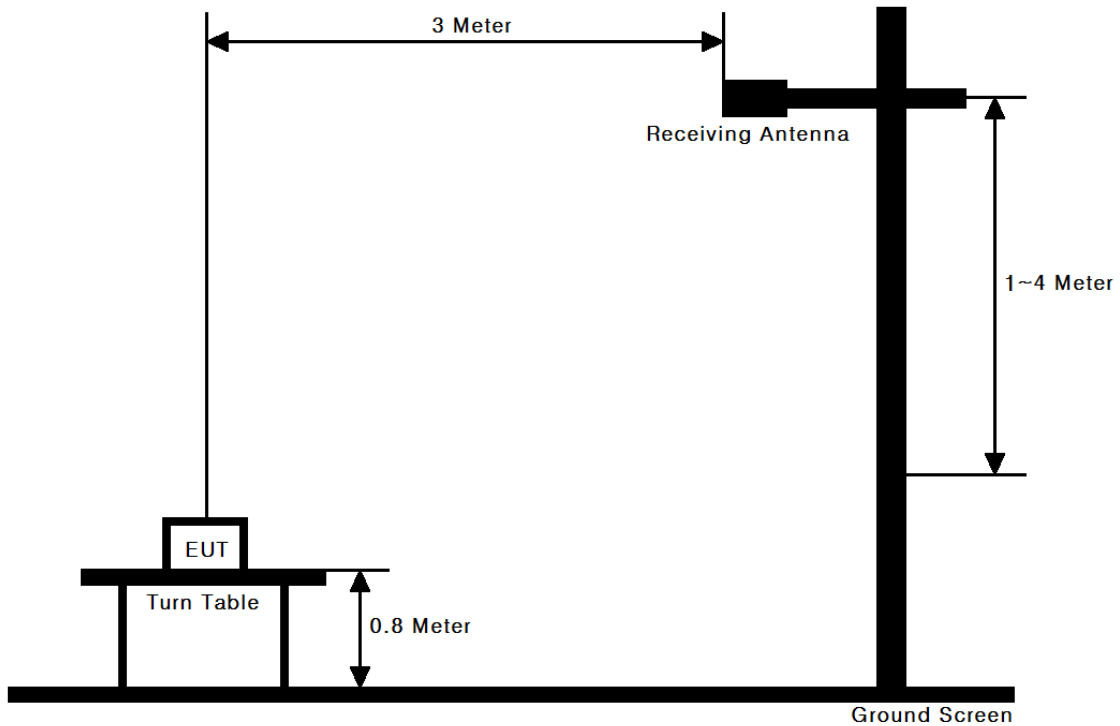

Test Procedure

These measurements were performed at 3&10m test site. The equipment under test is placed on a wooden turntable 0.8-meters above the ground plane and 3-meters from the receive antenna.

The receive antenna height and turntable rotations were adjusted for the highest reading on the receive spectrum analyzer.

A half-wave dipole was substituted in place of the EUT. This dipole antenna was driven by a signal generator and the level of the signal generator was adjusted to obtain the same receive spectrum analyzer reading.

For readings above 1GHz, the above procedure is repeated using horn antennas and the difference between the gain of the horn and an isotropic antenna are taken into consideration.

3.2 PEAK TO AVERAGE RATIO

A peak to average ratio measurement is performed at the conducted port of the EUT. For CDMA and WCDMA signals, the spectrum analyzers Complementary Cumulative Distribution Function (CCDF) measurement profile is used to determine the largest deviation between the average and the peak power of the EUT in a given bandwidth. The CCDF curve shows how much time the peak waveform spends at or above a given average power level. The percent of time the signal spends at or above the level defines the probability for that particular power level.

For GSM signals, an average and a peak trace are used on a spectrum analyzer to determine the largest deviation between the average and the peak power of the EUT in a bandwidth greater than the emission bandwidth. Plots of the EUT's Peak- to- Average Ratio are shown herein.

3.3 OCCUPIED BANDWIDTH.

Test set-up

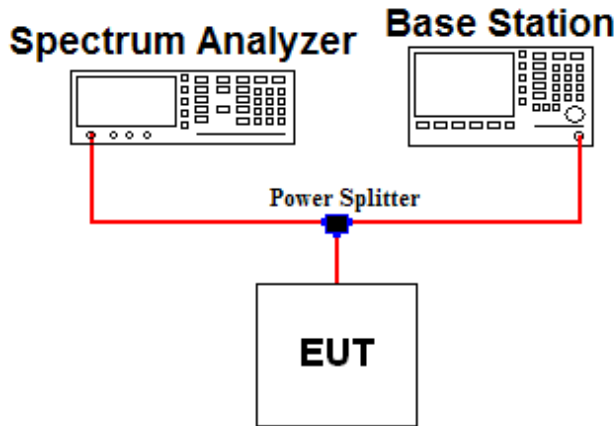

Offset value information

Frequency (MHz)	Offset Value (dB)	Frequency (MHz)	Offset Value (dB)
824.2	6.81	1850.2	7.33
826.4	6.81	1880.0	7.35
836.6	6.82	1909.8	7.36
846.6	6.83	-	-
848.8	6.83	-	-

Note. 1: The offset values from EUT to Spectrum analyzer were measured and used for test.
 Offset value = Cable A + Splitter + Cable B

Test Procedure

The EUT was setup to maximum output power at its lowest channel. The occupied bandwidth was measured using a spectrum analyzer. The measurements are repeated for the highest and a middle channel. The EUT's occupied bandwidth is measured as the width of the signal between two points, one below the carrier center frequency and one above the carrier frequency, outside of which all emissions are attenuated at least 26 dB below the transmitter power. Plots of the EUT's occupied bandwidth are shown herein.

3.4 SPURIOUS AND HARMONIC EMISSIONS AT ANTENNA TERMINAL.

Test set-up

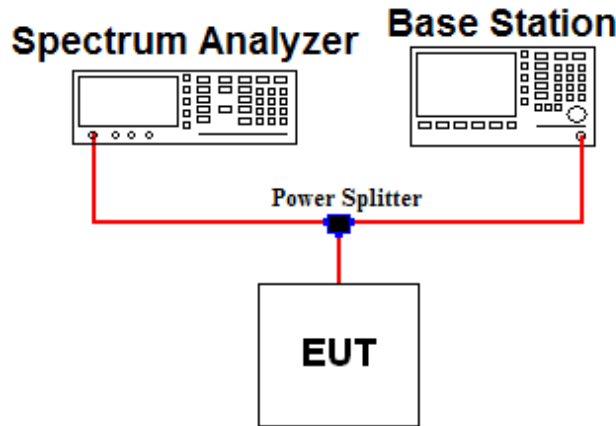

Offset value information

Frequency (MHz)	Offset Value (dB)	Frequency (MHz)	Offset Value (dB)	Frequency (MHz)	Offset Value (dB)
823.0	6.81	1850.0	7.33	15000.0	9.29
824.0	6.81	1910.0	7.37	20000.0	9.74
849.0	6.84	5000.0	8.39	-	-
850.0	6.84	10000.0	8.92	-	-

Note. 1: The offset value from EUT to Spectrum analyzer was measured and used for test.
 Offset value = Cable A + Splitter + Cable B

Test Procedure

The level of the carrier and the various conducted spurious and harmonic frequencies is measured by means of a calibrated spectrum analyzer.

The EUT was setup to maximum output power at its lowest channel. The spectrum is scanned from the lowest frequency generated in the equipment up to a frequency including its 10th harmonic. The Resolution BW of the analyzer is set to 1 % of the emission bandwidth to show compliance with -13dBm limit [$43+10\log(P)$], in the 1 MHz bands immediately outside and adjacent to the edge of the frequency block.

A display line was placed at -13dBm to show compliance. The high, lowest and a middle channel were tested for out of band measurements.

Band Edge Requirement

In the 1MHz bands immediately outside and adjacent to the frequency block, a resolution bandwidth of at least 1 percent of the emission bandwidth of the fundamental emission of the transmitter may be employed to measure the out of band Emissions.

3.5 RADIATED SPURIOUS EMISSIONS

Test Set-up

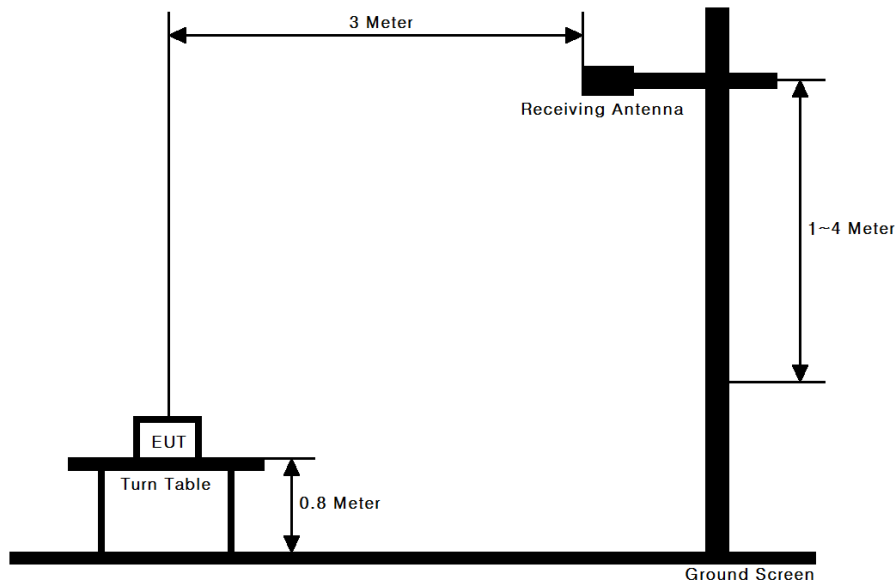

Test Procedure

This measurement was performed at 3meter test range. The equipment under test is placed on a wooden turntable 0.8-meters above the ground plane and 3-meters from the receive antenna.

The receive antenna height and turntable rotations were adjusted for the highest reading on the receive spectrum analyzer.

For radiated power measurements below 1GHz, a half-wave dipole was substituted in place of the EUT. This dipole antenna was driven by a signal generator and the level of the signal generator was adjusted to obtain the same spectrum analyzer reading.

For radiated power measurements above 1GHz, a Horn antenna was substituted in place of the EUT. This Horn antenna was driven by a signal generator and the level of the signal generator was adjusted to obtain the same spectrum analyzer reading. The difference between the gain of the horn and an isotropic antenna are taken into consideration.

This measurement was performed with the EUT oriented in 3 orthogonal axis.

3.6 FREQUENCY STABILITY / VARIATION OF AMBIENT TEMPERATURE

Test Set-up

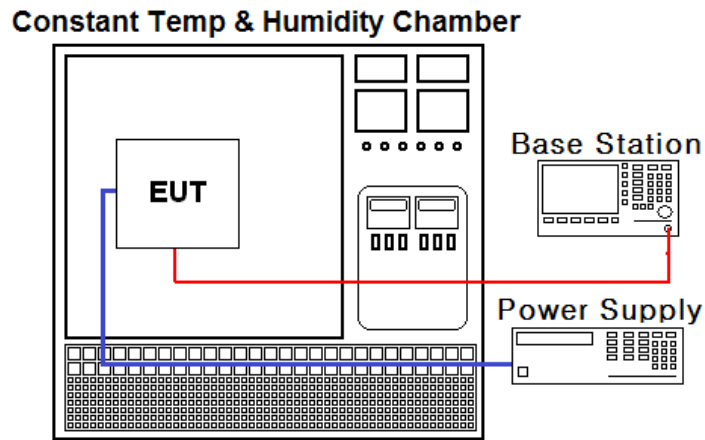

Test Procedure

The frequency stability of the transmitter is measured by:

- a.) **Temperature:** The temperature is varied from - 30 °C to + 50 °C using an environmental chamber.
- b.) **Primary Supply Voltage:** The primary supply voltage is varied from battery end point to 115 % of the voltage normally at the input to the device or at the power supply terminals if cables are not normally supplied.

Specification - the frequency stability shall be sufficient to ensure that the fundamental emission stays within the authorized frequency block. The frequency stability of the transmitter shall be maintained within $\pm 0.00025\%$ (± 2.5 ppm) of the center frequency.

Time Period and Procedure:

The carrier frequency of the transmitter is measured at room temperature. (25°C to provide a reference).

1. The equipment is turned on in a “standby” condition for one minute before applying power to the transmitter. Measurement of the carrier frequency of the transmitter is made within one minute after applying power to the transmitter.
2. Frequency measurements are made at 10°C intervals ranging from -30°C to +50°C. A period of at least one half-hour is provided to allow stabilization of the equipment at each temperature level.

NOTE: The EUT is tested down to the battery endpoint.

4. LIST OF TEST EQUIPMENT

Type	Manufacturer	Model	Cal. Date (yy/mm/dd)	Next. Cal. Date (yy/mm/dd)	S/N
Spectrum Analyzer	Agilent	E4440A	11/09/30	12/09/30	MY45304199
Spectrum Analyzer	Agilent	N9020A	12/01/09	13/01/09	MY49100833
8960 Series 10 Wireless Comms. Test Set	Agilent	E5515C	12/03/05	13/03/05	GB43461134
Thermo hygrometer	BODYCOM	BJ5478	12/01/13	13/01/13	090205-2
TEMP & HUMIDITY Chamber	JISCO	KR-100/J-RHC2	11/09/30	12/09/30	30604493/021031
Signal Generator	Rohde Schwarz	SMR20	12/03/05	13/03/05	101251
Vector Signal Generator	Rohde Schwarz	SMJ100A	12/01/09	13/01/09	100148
Amplifier	EMPOWER	BBS3Q7ELU	11/09/30	12/09/30	1020
DC Power Supply	HP	6622A	12/03/05	13/03/05	3448A03760
Digital Multi-meter	H.P	34401A	12/03/05	13/03/05	3146A13475, US36122178
Attenuator (3dB)	WEINSCHEL	56-3	11/09/30	12/09/30	Y2342
Attenuator (10dB)	WEINSCHEL	23-10-34	11/09/30	12/09/30	BP4386
Power Splitter	Anritsu	K241B	11/09/30	12/09/30	020611
High-Pass Filter	Wainwright	WHKX1.0	11/09/30	12/09/30	9
High-Pass Filter	Wainwright	WHNX2.1	11/09/30	12/09/30	1
Amplifier (25dB)	Agilent	8447D	12/03/05	13/03/05	2944A10144
Amplifier (30dB)	Agilent	8449B	12/03/05	13/03/05	3008A01590
Dipole Antenna	Schwarzbeck	VHA9103	11/11/22	12/11/22	2116
Dipole Antenna	Schwarzbeck	VHA9103	11/11/22	12/11/22	2117
Dipole Antenna	Schwarzbeck	UHA9105	11/11/22	12/11/22	2261
Dipole Antenna	Schwarzbeck	UHA9105	11/11/22	12/11/22	2262
BICONICAL ANT.	Schwarzbeck	VHA 9103	10/12/21	12/12/21	91031946
LOG-PERIODIC ANT.	Schwarzbeck	UHALP9108A1	10/11/29	12/11/29	1098
HORN ANT	ETS	3115	12/02/20	13/02/20	6419
HORN ANT	A.H.Systems	SAS-574	11/03/25	13/03/25	154
HORN ANT	A.H.Systems	SAS-574	11/03/25	13/03/25	155

5. SUMMARY OF TEST RESULTS

FCC Part Section(s)	Parameter	Status Note 1
2.1046	Conducted Output Power	C
22.913(a) 24.232(c)	Effective Radiated Power Equivalent Isotropic Radiated Power	C
22.917(a) 24.238(a) 2.1049	Occupied Bandwidth	C
22.917(a) 24.238(a) 2.1051	Band Edge Spurious and Harmonic Emissions at Antenna Terminal	C
24.232(d)	Peak to Average Ratio	C
22.917(a) 24.238(a) 2.1053	Radiated Spurious and Harmonic Emissions	C
22.355 24.235 2.1055	Frequency Stability	C
Note 1: C =Comply NC =Not Comply NT =Not Tested NA =Not Applicable		

The sample was tested according to the following specification:
 ANSI/TIA/EIA-603-C-2004

6. SAMPLE CALCULATION

A. Emission Designator

GSM850 Emission Designator

Emission Designator = **244KGXW**
GSM OBW = 243.6984kHz
(Measured at the 99.75% power bandwidth)
G = Phase Modulation
X = Cases not otherwise covered
W = Combination (Audio/Data)

EDGE850 Emission Designator

Emission Designator = **244KG7W**
GSM OBW = 244.1560 kHz
(Measured at the 99.75% power bandwidth)
G = Phase Modulation
7 = Two or more channels containing
quantized or digital information
W = Combination (Audio/Data)

WCDMA850 Emission Designator

Emission Designator = **4M06F9W**
WCDMA OBW = 4.05720MHz
(Measured at the 99.75% power bandwidth)
F = Frequency Modulation
9 = Composite Digital Information
W = Combination (Audio/Data)

GSM1900 Emission Designator

Emission Designator = **244KGXW**
GSM OBW = 243.8844kHz
(Measured at the 99.75% power bandwidth)
G = Phase Modulation
X = Cases not otherwise covered
W = Combination (Audio/Data)

EDGE1900 Emission Designator

Emission Designator = **246KG7W**
GSM OBW = 245.8758 kHz
(Measured at the 99.75% power bandwidth)
G = Phase Modulation
7 = Two or more channels containing
quantized or digital information
W = Combination (Audio/Data)

HSUPA850 Emission Designator

Emission Designator = **4M05F9W**
HSUPA OBW = 4.04720MHz
(Measured at the 99.75% power bandwidth)
F = Frequency Modulation
9 = Composite Digital Information
W = Combination (Audio/Data)

7. TEST DATA

7.1 CONDUCTED OUTPUT POWER

A base station simulator was used to establish communication with the EUT. The base station simulator parameters were set to produce the maximum power from the EUT. This device was tested under all configurations and the highest power is reported. Conducted Output Powers of EUT are reported below.

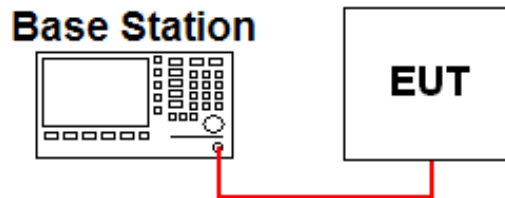

▪ GSM / GPRS / EDGE

Band	Channel	Test Result(dBm)								
		GSM	GPRS 1 TX Slot	GPRS 2 TX Slot	GPRS 3 TX Slot	GPRS 4 TX Slot	EDGE 1 TX Slot	EDGE 2 TX Slot	EDGE 3 TX Slot	EDGE 4 TX Slot
Cellular	128	33.60	33.50	31.70	30.70	28.70	27.60	25.50	24.50	22.50
	190	33.60	33.50	31.60	30.70	28.70	27.60	25.50	24.50	22.50
	251	33.50	33.50	31.60	30.60	28.60	27.50	25.50	24.40	22.50
PCS	512	30.70	30.70	28.50	27.50	25.50	26.70	24.50	23.40	21.60
	661	30.60	30.60	28.50	27.50	25.60	26.60	24.50	23.40	21.60
	810	30.60	30.60	28.50	27.50	25.60	26.60	24.50	23.40	21.60

The output power was measured using the Agilent E5515C

▪ WCDMA

3GPP Release Version	Mode		Power (dBm)			MPR	B _c	β _d	B _c /β _d	Sub-Test
	Channel		4132	4183	4233					
99	WCDMA	RMC	23.69	23.65	23.64	-	-	-	-	-
		ARM	23.65	23.61	23.61					
5	HSDPA (Cellular)		23.63	23.58	23.60	0	2/15	15/15	2/15	1
5			23.61	23.55	23.51	0	12/15	15/15	12/15	2
5			23.05	22.98	22.99	0.5	15/15	8/15	15/8	3
5			22.97	22.94	22.94	0.5	15/15	4/15	15/4	4
-	Channel		9262	9400	9538	-	-	-	-	-
99	WCDMA	RMC	N/A	N/A	N/A	-	-	-	-	-
		ARM	N/A	N/A	N/A					
5	HSDPA (PCS)		N/A	N/A	N/A	0	2/15	15/15	2/15	1
5			N/A	N/A	N/A	0	12/15	15/15	12/15	2
5			N/A	N/A	N/A	0.5	15/15	8/15	15/8	3
5			N/A	N/A	N/A	0.5	15/15	4/15	15/4	4

The output power was measured using the Agilent E5515C

▪ HSUPA

3GPP Release Version	Mode		Power (dBm)			MPR	B _c	β _d	B _c /β _d	Sub-Test
	Channel		4132	4183	4233					
6	HSUPA (Cellular)		23.64	23.59	23.55	0	11/15	15/15	11/15	1
6			21.08	21.05	21.01	2	6/15	15/15	6/15	2
6			22.54	22.51	22.52	1	15/15	9/15	15/9	3
6			20.97	20.95	20.93	2	2/15	15/15	2/15	4
6			23.57	23.55	23.51	0	15/15	15/15	15/15	5
-	Channel		9262	9400	9538	-	-	-	-	-
6	HSUPA (PCS)		N/A	N/A	N/A	0	11/15	15/15	11/15	1
6			N/A	N/A	N/A	2	6/15	15/15	6/15	2
6			N/A	N/A	N/A	1	15/15	9/15	15/9	3
6			N/A	N/A	N/A	2	2/15	15/15	2/15	4
6			N/A	N/A	N/A	0	15/15	15/15	15/15	5

The output power was measured using the Agilent E5515C

7.2 PEAK TO AVERAGE RATIO

- Plots of the EUT’s Peak- to- Average Ratio are shown in Clause 8.1

7.3 OCCUPIED BANDWIDTH

Band	Channel	Test Result(KHz)
GSM850	128	243.5490
	190	243.6984
	251	241.2780
EDGE850	128	243.7087
	190	244.1560
	251	243.1114
WCDMA850	4132	4057.2
	4183	4052.5
	4233	4048.3
HSUPA850	4132	4040.5
	4183	4047.2
	4233	4029.5
GSM1900	512	243.6736
	661	241.6988
	810	243.8844
EDGE1900	512	243.6279
	661	245.8758
	810	243.3596

- Plots of the EUT’s Occupied Bandwidth are shown in Clause 8.2

7.4 SPURIOUS AND HARMONIC EMISSIONS AT ANTENNA TERMINAL

- Plots of the EUT’s Conducted Spurious Emissions are shown in Clause 8.3

7.5 BAND EDGE

- Plots of the EUT’s Band Edge are shown in Clause 8.4

7.6 EFFECTIVE RADIATED POWER(GSM850/ WCDMA850/ HSUPA850)

- GSM850 data

CH.	EUT Position (Axis)	TEST CONDITIONS Power Step: 5							
		Reading Value (dBm)	Pol. (H/V)	LEVEL@ TX ANTENNA TERMINAL (dBm)	Antenna Gain (dBd)	ERP (dBm)	ERP (W)	Power Supply	Note.
128	X	-3.12	H	29.59	1.20	30.79	1.199	DC 3.8V	GSM
190	X	-3.78	H	30.22	1.15	31.37	1.371	DC 3.8V	GSM
251	X	-4.43	H	29.17	1.05	30.22	1.052	DC 3.8V	GSM
190	X	-6.96	H	27.04	1.15	28.19	0.659	DC 3.8V	EDGE

- WCDMA850 data

CH.	EUT Position (Axis)	TEST CONDITIONS							
		Reading Value (dBm)	Pol. (H/V)	LEVEL@ TX ANTENNA TERMINAL (dBm)	Antenna Gain (dBd)	ERP (dBm)	ERP (W)	Power Supply	Note.
4132	X	-10.24	H	22.70	1.19	23.89	0.245	DC 3.8V	-
4183	X	-10.67	H	23.59	1.15	24.74	0.298	DC 3.8V	-
4233	X	-10.35	H	24.09	1.10	25.19	0.330	DC 3.8V	-

- HSUPA850 data

CH.	EUT Position (Axis)	TEST CONDITIONS							
		Reading Value (dBm)	Pol. (H/V)	LEVEL@ TX ANTENNA TERMINAL (dBm)	Antenna Gain (dBd)	ERP (dBm)	ERP (W)	Power Supply	Note.
4132	X	-10.31	H	22.63	1.19	23.82	0.241	DC 3.8V	-
4183	X	-10.91	H	23.35	1.15	24.50	0.282	DC 3.8V	-
4233	X	-10.64	H	23.80	1.10	24.90	0.309	DC 3.8V	-

NOTES:

Effective Radiated Power Output Measurements by Substitution Method according to ANSI/TIA/EIA-603-C-2004, Aug. 17, 2004:

The EUT is placed on a wooden turn table 3-meters from the receive antenna. The receive antenna height and turntable rotation is adjusted for the highest reading on the receive spectrum analyzer. For CDMA signals, a peak detector is used, with RBW = VBW = 3 MHz. For WCDMA signals, a peak detector is used, with RBW = VBW = 5MHz. For AMPS, GSM, and TDMA signals, a peak detector is used, with RBW = VBW = 1 MHz.

A half-wave dipole is substituted in place of the EUT. This dipole antenna is driven by a signal generator and the level of the signal generator is adjusted to obtain the same receive spectrum analyzer reading. The conducted power at the terminals of the dipole is measured. The ERP is recorded.

This device was tested under all configurations and the highest power is reported in GSM mode. This EUT was tested with the fully charged battery. Also, we have done x, y, z planes in EUT and horizontal and vertical polarization of detecting antenna. The worst case data is reported.

7.7 EQUIVALENT ISOTROPIC RADIATED POWER(GSM1900)

- GSM1900 data

CH.	EUT Position (Axis)	TEST CONDITIONS Power Step: 0							
		Reading Value (dBm)	Pol. (H/V)	LEVEL@ TX ANTENNA TERMINAL (dBm)	Antenna Gain (dBi)	EIRP (dBm)	EIRP (W)	Power Supply	Note.
512	Z	-11.56	V	20.24	8.59	28.83	0.764	DC 3.8V	GSM
661	Z	-10.98	V	20.19	8.68	28.87	0.771	DC 3.8V	GSM
810	Z	-10.20	V	20.82	8.77	29.59	0.910	DC 3.8V	GSM
810	Z	-13.45	H	17.57	8.77	26.34	0.431	DC 3.8V	EDGE

NOTES:

Effective Radiated Power Output Measurements by Substitution Method according to ANSI/TIA/EIA-603-C-2004, Aug. 17, 2004:

The EUT is placed on a wooden turn table 3-meters from the receive antenna. The receive antenna height and turntable rotation is adjusted for the highest reading on the receive spectrum analyzer. For CDMA signals, a peak detector is used, with RBW = VBW = 3 MHz. For WCDMA signals, a peak detector is used, with RBW = VBW = 5MHz. For AMPS, GSM, and TDMA signals, a peak detector is used, with RBW = VBW = 1 MHz. A half-wave dipole is substituted in place of the EUT. This dipole antenna is driven by a signal generator and the level of the signal generator is adjusted to obtain the same receive spectrum analyzer reading. The conducted power at the terminals of the dipole is measured. The ERP is recorded.

This device was tested under all configurations and the highest power is reported in GSM mode. This EUT was tested with the fully charged battery. Also, we have done x, y, z planes in EUT and horizontal and vertical polarization of detecting antenna. The worst case data is reported.

7.8 RADIATED SPURIOUS EMISSIONS

7.8.1 RADIATED SPURIOUS EMISSIONS (GSM850)

Channel (ERP)	Freq. (MHz)	EUT Position (Axis)	POL (H/V)	LEVEL@ ANTENNA TERMINAL (dBm)	SUBSTITUTE ANTENNA GAIN (dBd)	CORRECT GENERATOR LEVEL (dBm)	(dBc)	Limit (dBc)
128 (1.199W)	1648.14	Y	H	-57.64	5.48	-52.16	82.95	43.79
	4120.57	Y	H	-53.61	7.91	-45.70	76.49	
	4944.48	Y	V	-50.04	8.73	-41.31	72.10	
190 (1.371W)	1672.97	Y	H	-56.39	5.53	-50.86	82.23	44.37
	4182.72	Y	H	-56.10	7.97	-48.13	79.50	
	5020.12	Y	V	-53.27	8.80	-44.47	75.84	
251 (1.052W)	1697.33	Y	H	-54.15	5.59	-48.56	78.78	43.22
	4243.78	Y	H	-57.15	8.03	-49.12	79.34	
	5091.99	Y	V	-53.78	8.85	-44.93	75.15	

- Limit Calculation = $43 + 10 \log_{10} (ERP [W])$ [dBc]

- No other spurious and harmonic emissions were reported greater than listed emissions above table.

NOTES:

Effective Radiated Power Output Measurements by Substitution Method according to ANSI/TIA/EIA-603-C-2004, Aug. 17, 2004:

The EUT is placed on a wooden turn table 3-meters from the receive antenna. The receive antenna height and turntable rotation is adjusted for the highest reading on the receive spectrum analyzer.

A half-wave dipole was substituted in place of the EUT. This dipole antenna was driven by a signal generator and the level of the signal generator was adjusted to obtain the same receive spectrum analyzer reading. This spurious level is recorded. For readings above 1GHz, the above procedure is repeated using horn antennas and the difference between the gain of the horn and an isotropic or dipole antenna are taken into consideration.

This device was tested under all configurations and the highest power is reported in GSM mode and using a Power Control Level of "0" in the PCS Band and "5" in the Cellular Band.

This EUT was tested with the fully charged battery. Also, we have done x, y, z planes in EUT and horizontal and vertical polarization of detecting antenna.

The worst case data is reported.

7.8.2 RADIATED SPURIOUS EMISSIONS (WCDMA850)

Channel (EIRP)	Freq. (MHz)	EUT Position (Axis)	POL (H/V)	LEVEL@ ANTENNA TERMINAL (dBm)	SUBSTITUTE ANTENNA GAIN (dBd)	CORRECT GENERATOR LEVEL (dBm)	(dBc)	Limit (dBc)
4132 (0.245W)	1653.64	Z	V	-60.15	5.49	-54.66	78.55	36.89
	-	-	-	-	-	-	-	
	-	-	-	-	-	-	-	
4183 (0.298W)	1673.07	Z	V	-60.37	5.53	-54.84	79.58	37.74
	-	-	-	-	-	-	-	
	-	-	-	-	-	-	-	
4233 (0.330W)	1691.37	Z	V	-58.42	5.57	-52.85	78.04	38.19
	-	-	-	-	-	-	-	
	-	-	-	-	-	-	-	

- Limit Calculation = $43 + 10 \log_{10} (ERP [W])$ [dBc]

- No other spurious and harmonic emissions were reported greater than listed emissions above table.

NOTES:

Effective Radiated Power Output Measurements by Substitution Method according to ANSI/TIA/EIA-603-C-2004, Aug. 17, 2004:

The EUT is placed on a wooden turn table 3-meters from the receive antenna. The receive antenna height and turntable rotation is adjusted for the highest reading on the receive spectrum analyzer.

A half-wave dipole was substituted in place of the EUT. This dipole antenna was driven by a signal generator and the level of the signal generator was adjusted to obtain the same receive spectrum analyzer reading. This spurious level is recorded. For readings above 1GHz, the above procedure is repeated using horn antennas and the difference between the gain of the horn and an isotropic or dipole antenna are taken into consideration.

This device was tested under all configurations and the highest power is reported.

This EUT was tested with the fully charged battery. Also, we have done x, y, z planes in EUT and horizontal and vertical polarization of detecting antenna.

The worst case data is reported.

7.8.3 RADIATED SPURIOUS EMISSIONS (HSUPA850)

Channel (ERP)	Freq. (MHz)	EUT Position (Axis)	POL (H/V)	LEVEL@ ANTENNA TERMINAL (dBm)	SUBSTITUTE ANTENNA GAIN (dBd)	CORRECT GENERATOR LEVEL (dBm)	(dBc)	Limit (dBc)
4132 (0.241W)	1653.75	Z	V	-60.29	5.49	-54.80	78.62	36.82
	-	-	-	-	-	-	-	
	-	-	-	-	-	-	-	
4183 (0.282W)	1672.42	Z	V	-60.67	5.53	-55.14	79.64	37.50
	-	-	-	-	-	-	-	
	-	-	-	-	-	-	-	
4233 (0.309W)	1690.97	Z	V	-57.58	5.57	-52.01	76.91	37.90
	-	-	-	-	-	-	-	
	-	-	-	-	-	-	-	

- Limit Calculation = $43 + 10 \log_{10} (\text{ERP [W]})$ [dBc]

- No other spurious and harmonic emissions were reported greater than listed emissions above table.

NOTES:

Effective Radiated Power Output Measurements by Substitution Method according to ANSI/TIA/EIA-603-C-2004, Aug. 17, 2004:

The EUT is placed on a wooden turn table 3-meters from the receive antenna. The receive antenna height and turntable rotation is adjusted for the highest reading on the receive spectrum analyzer.

A half-wave dipole was substituted in place of the EUT. This dipole antenna was driven by a signal generator and the level of the signal generator was adjusted to obtain the same receive spectrum analyzer reading. This spurious level is recorded. For readings above 1GHz, the above procedure is repeated using horn antennas and the difference between the gain of the horn and an isotropic or dipole antenna are taken into consideration.

This device was tested under all configurations and the highest power is reported.

This EUT was tested with the fully charged battery. Also, we have done x, y, z planes in EUT and horizontal and vertical polarization of detecting antenna.

The worst case data is reported.

7.8.4 RADIATED SPURIOUS EMISSIONS (GSM1900)

Channel (EIRP)	Freq. (MHz)	EUT Position (Axis)	POL (H/V)	LEVEL@ ANTENNA TERMINAL (dBm)	SUBSTITUTE ANTENNA GAIN (dBi)	CORRECT GENERATOR LEVEL (dBm)	(dBc)	Limit (dBc)
512 (0.764W)	3699.97	Y	H	-53.06	9.67	-43.39	72.22	41.83
	5550.55	Z	H	-53.87	11.11	-42.76	71.59	
	7401.21	Z	H	-47.43	11.53	-35.90	64.73	
	-	-	-	-	-	-	-	
661 (0.771W)	3759.68	Y	H	-55.43	9.68	-45.75	74.62	41.87
	5639.89	Z	H	-52.19	11.16	-41.03	69.90	
	7520.27	Z	H	-45.76	11.51	-34.25	63.12	
	-	-	-	-	-	-	-	
810 (0.910W)	3819.14	Y	H	-51.17	9.68	-41.49	71.08	42.59
	5729.26	Z	H	-50.61	11.21	-39.40	68.99	
	7639.18	Z	H	-44.11	11.48	-32.63	62.22	
	-	-	-	-	-	-	-	

- Limit Calculation = $43 + 10 \log_{10} (\text{EIRP [W]})$ [dBc]

- No other spurious and harmonic emissions were reported greater than listed emissions above table.

NOTES:

Effective Radiated Power Output Measurements by Substitution Method according to ANSI/TIA/EIA-603-C-2004, Aug. 17, 2004:

The EUT is placed on a wooden turn table 3-meters from the receive antenna. The receive antenna height and turntable rotation is adjusted for the highest reading on the receive spectrum analyzer.

A half-wave dipole was substituted in place of the EUT. This dipole antenna was driven by a signal generator and the level of the signal generator was adjusted to obtain the same receive spectrum analyzer reading. This spurious level is recorded. For readings above 1GHz, the above procedure is repeated using horn antennas and the difference between the gain of the horn and an isotropic or dipole antenna are taken into consideration.

This device was tested under all configurations and the highest power is reported in GSM mode and using a Power Control Level of “0” in the PCS Band and “5” in the Cellular Band.

This EUT was tested with the fully charged battery. Also, we have done x, y, z planes in EUT and horizontal and vertical polarization of detecting antenna.

The worst case data is reported.

7.9 FREQUENCY STABILITY / VARIATION OF AMBIENT TEMPERATURE

7.9.1 FREQUENCY STABILITY (GSM850)

OPERATING FREQUENCY : 836,599,968 Hz
 CHANNEL : 190(Mid)
 REFERENCE VOLTAGE : 3.80 V DC
 DEVIATION LIMIT : ± 0.00025 % or 2.5 ppm

VOLTAGE (%)	POWER (V DC)	TEMP (°C)	FREQ (Hz)	Deviation	
				(ppm)	(%)
100%	3.80	+25(Ref)	836,599,968	0.000	0.00000000
100%		-30	836,599,987	0.023	0.00000227
100%		-20	836,599,977	0.011	0.00000108
100%		-10	836,599,970	0.002	0.00000024
100%		0	836,599,982	0.017	0.00000167
100%		+10	836,599,975	0.008	0.00000084
100%		+20	836,599,964	-0.005	-0.00000048
100%		+30	836,599,988	0.024	0.00000239
100%		+40	836,599,960	-0.010	-0.00000096
100%		+50	836,599,969	0.001	0.00000012
85%	3.23	+25	836,599,978	0.012	0.00000120
115%	4.37	+25	836,599,981	0.016	0.00000155
BATT.ENDPOINT	3.20	+25	836,599,974	0.007	0.00000072

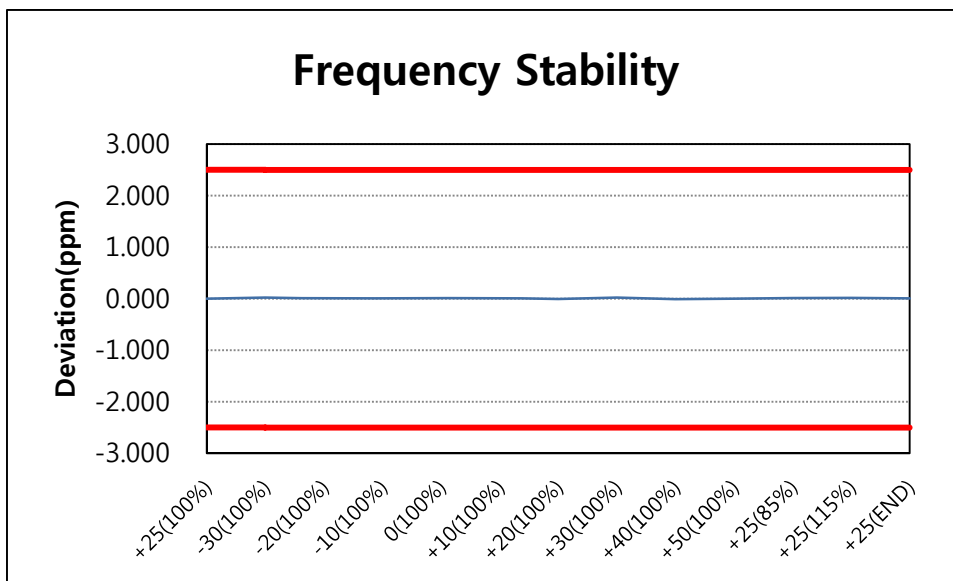

7.9.2 FREQUENCY STABILITY (WCDMA850)

OPERATING FREQUENCY : 836,599,975 Hz
 CHANNEL : 4183(Mid)
 REFERENCE VOLTAGE : 3.80 V DC
 DEVIATION LIMIT : ± 0.00025 % or 2.5 ppm

VOLTAGE (%)	POWER (V DC)	TEMP (°C)	FREQ (Hz)	Deviation	
				(ppm)	(%)
100%	3.80	+25(Ref)	836,599,975	0.000	0.00000000
100%		-30	836,599,992	0.020	0.00000203
100%		-20	836,599,996	0.025	0.00000251
100%		-10	836,599,986	0.013	0.00000131
100%		0	836,599,978	0.004	0.00000036
100%		+10	836,599,980	0.006	0.00000060
100%		+20	836,599,974	-0.001	-0.00000012
100%		+30	836,600,015	0.048	0.00000478
100%		+40	836,600,022	0.056	0.00000562
100%		+50	836,600,018	0.051	0.00000514
85%		3.23	+25	836,599,963	-0.014
115%	4.37	+25	836,599,979	0.005	0.00000048
BATT.ENDPOINT	3.20	+25	836,599,974	-0.001	-0.00000012

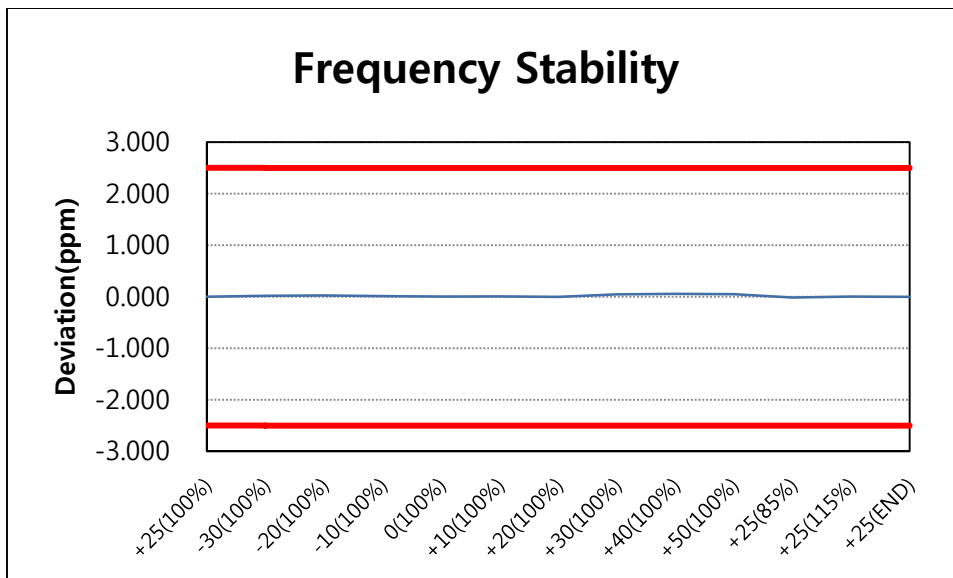

7.9.3 FREQUENCY STABILITY (HSUPA850)

OPERATING FREQUENCY : 836,599,968 Hz
 CHANNEL : 4183(Mid)
 REFERENCE VOLTAGE : 3.80 V DC
 DEVIATION LIMIT : ± 0.00025 % or 2.5 ppm

VOLTAGE (%)	POWER (V DC)	TEMP (°C)	FREQ (Hz)	Deviation	
				(ppm)	(%)
100%	3.80	+25(Ref)	836,599,968	0.000	0.00000000
100%		-30	836,599,991	0.027	0.00000275
100%		-20	836,600,017	0.059	0.00000586
100%		-10	836,600,005	0.044	0.00000442
100%		0	836,599,972	0.005	0.00000048
100%		+10	836,599,980	0.014	0.00000143
100%		+20	836,599,987	0.023	0.00000227
100%		+30	836,600,008	0.048	0.00000478
100%		+40	836,600,011	0.051	0.00000514
100%		+50	836,600,021	0.063	0.00000634
85%		3.23	+25	836,599,966	-0.002
115%	4.37	+25	836,599,958	-0.012	-0.00000120
BATT.ENDPOINT	3.20	+25	836,599,970	0.002	0.00000024

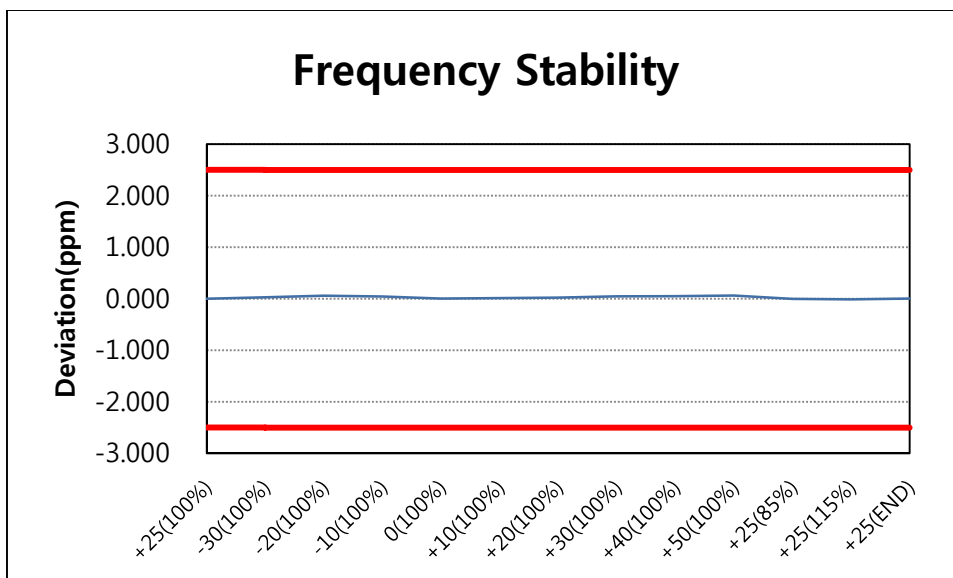

7.9.4 FREQUENCY STABILITY (GSM1900)

OPERATING FREQUENCY : 1,879,999,973 Hz
 CHANNEL : 661(Mid)
 REFERENCE VOLTAGE : 3.80 V DC
 DEVIATION LIMIT : ± 0.00025 % or 2.5 ppm

VOLTAGE (%)	POWER (V DC)	TEMP (°C)	FREQ (Hz)	Deviation	
				(ppm)	(%)
100%	3.80	+25(Ref)	1,879,999,973	0.000	0.00000000
100%		-30	1,879,999,984	0.006	0.00000059
100%		-20	1,879,999,994	0.011	0.00000112
100%		-10	1,879,999,998	0.013	0.00000133
100%		0	1,879,999,988	0.008	0.00000080
100%		+10	1,879,999,986	0.007	0.00000069
100%		+20	1,879,999,968	-0.003	-0.00000027
100%		+30	1,880,000,013	0.021	0.00000213
100%		+40	1,880,000,009	0.019	0.00000191
100%		+50	1,880,000,016	0.023	0.00000229
85%	3.23	+25	1,879,999,971	-0.001	-0.00000011
115%	4.37	+25	1,879,999,986	0.007	0.00000069
BATT.ENDPOINT	3.20	+25	1,879,999,975	0.001	0.00000011

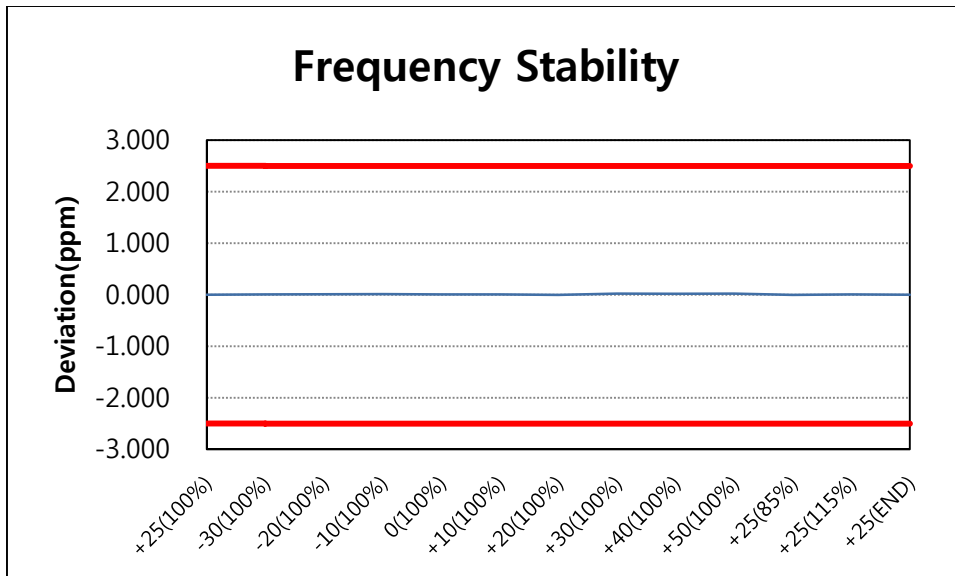

8. TEST PLOTS

8.1 Peak to Average Ratio

GSM1900 & Channel: 661

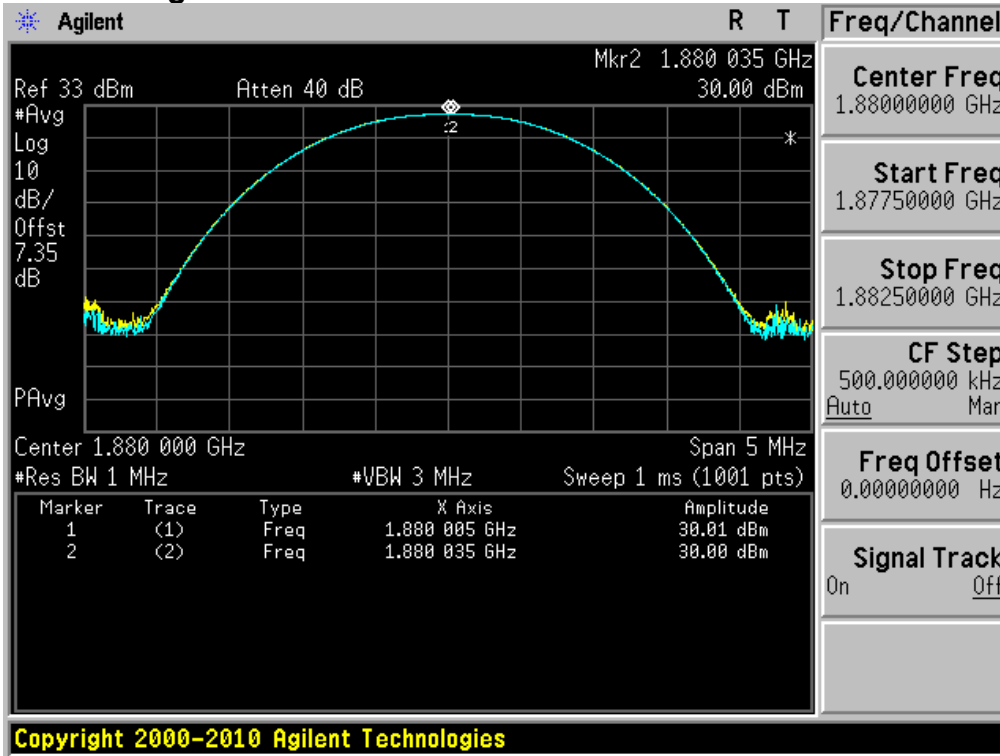

EDGE1900 & Channel: 661

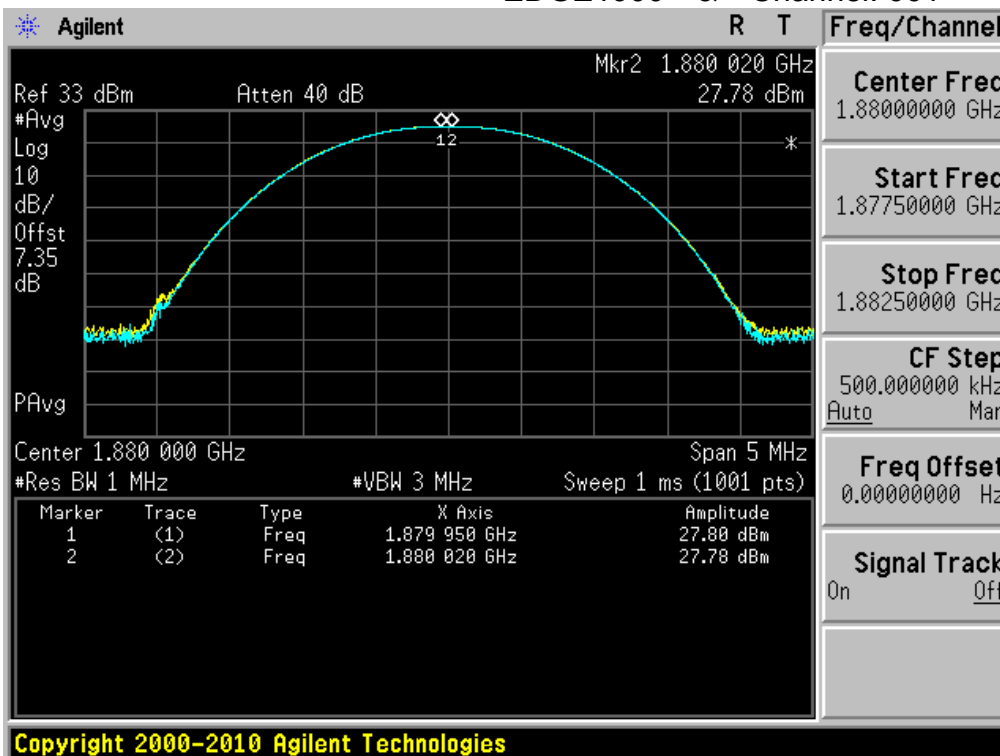

8.2 Occupied Bandwidth 99 % Bandwidth

GSM850 & Channel: 128

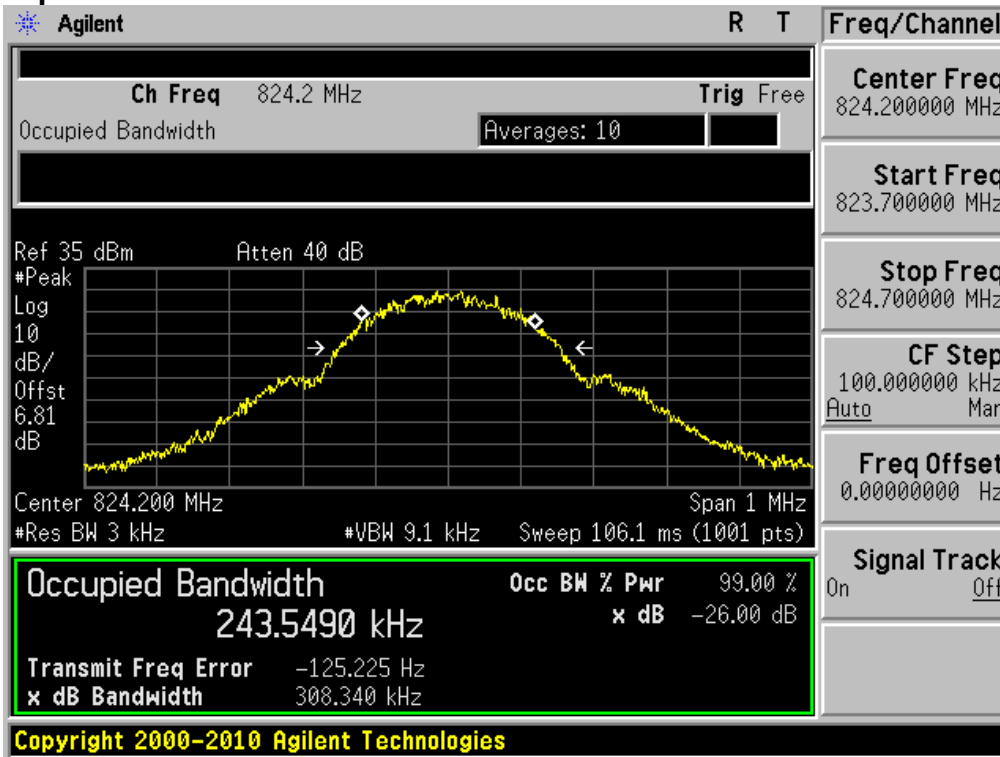

GSM850 & Channel: 190

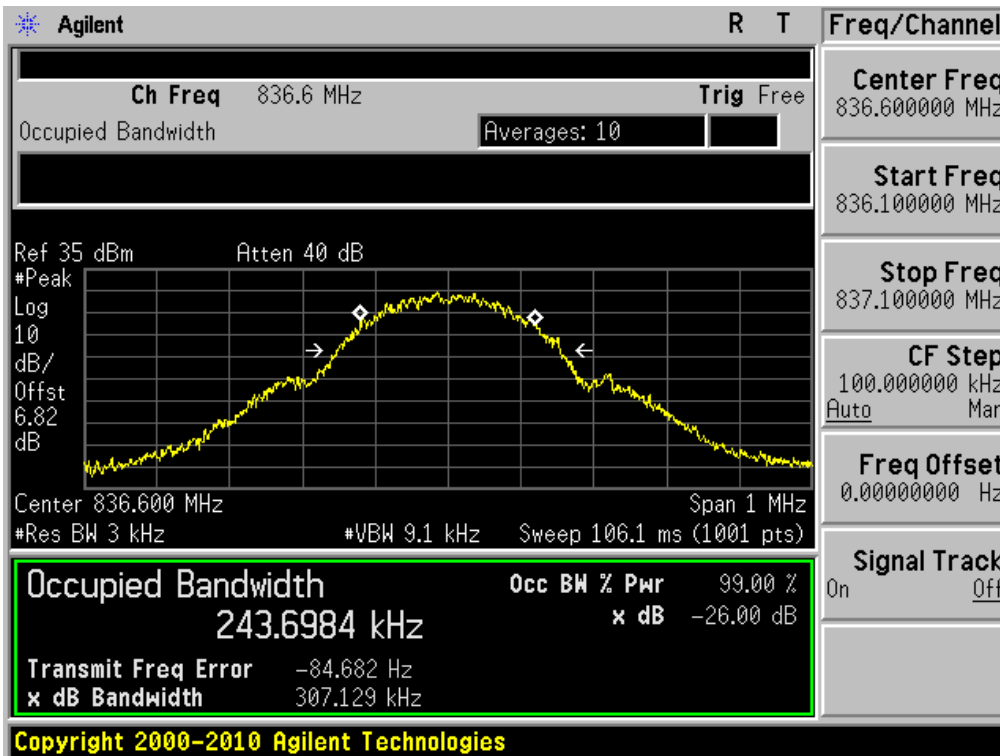

GSM850 & Channel: 251

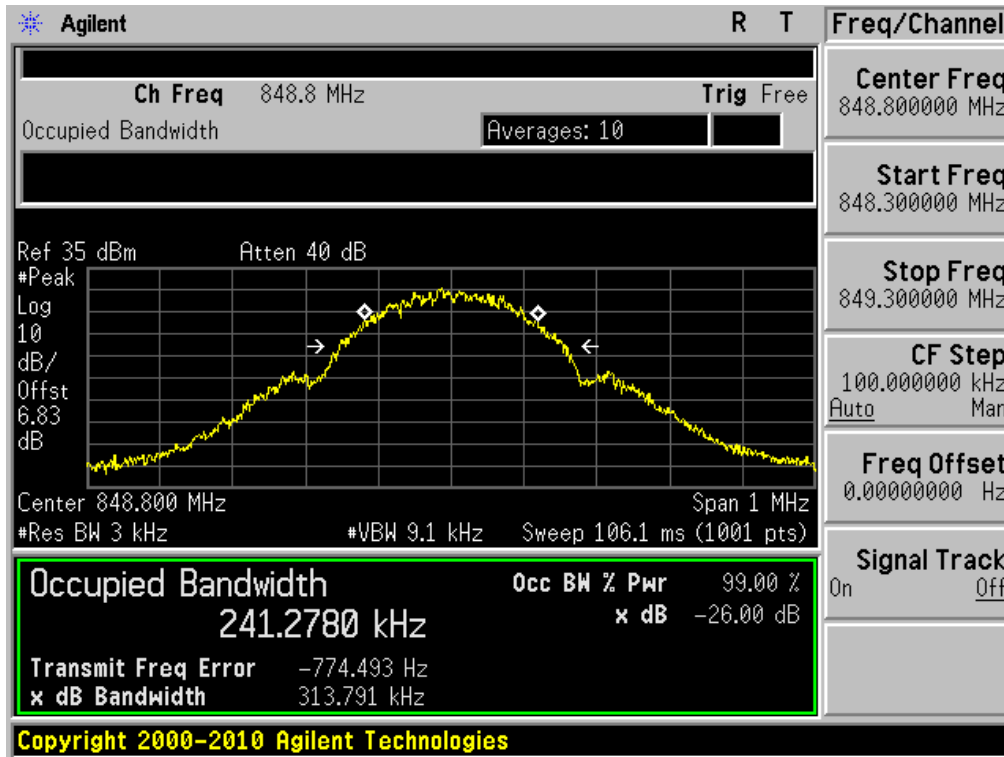

EDGE 850 & Channel: 128

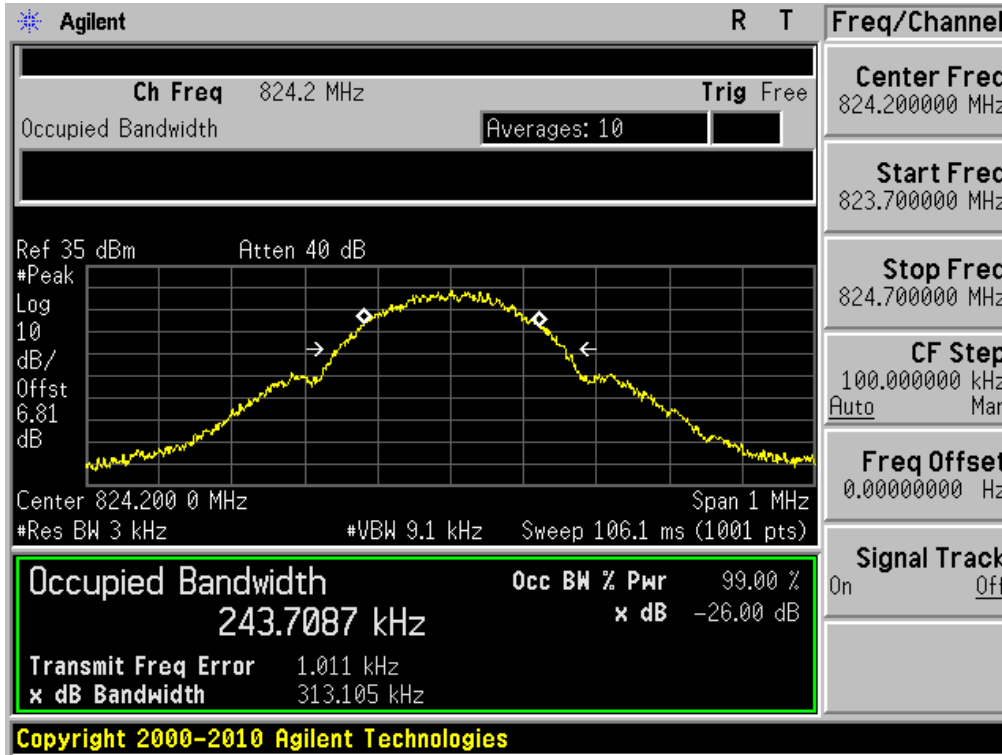

EDGE 850 & Channel: 190

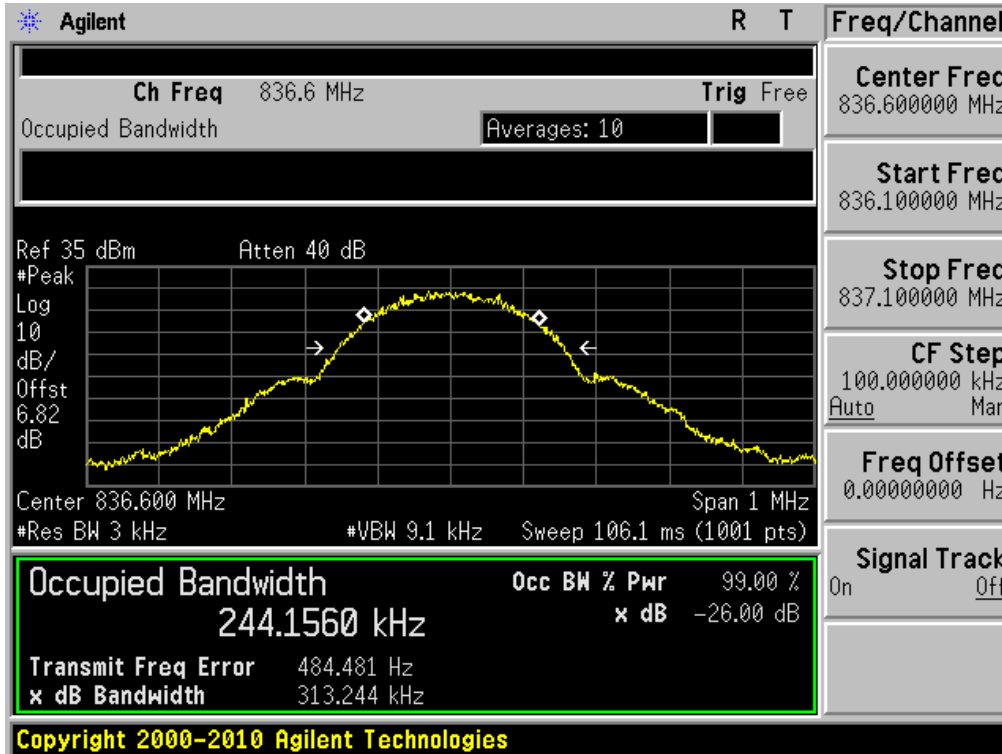

EDGE 850 & Channel: 251

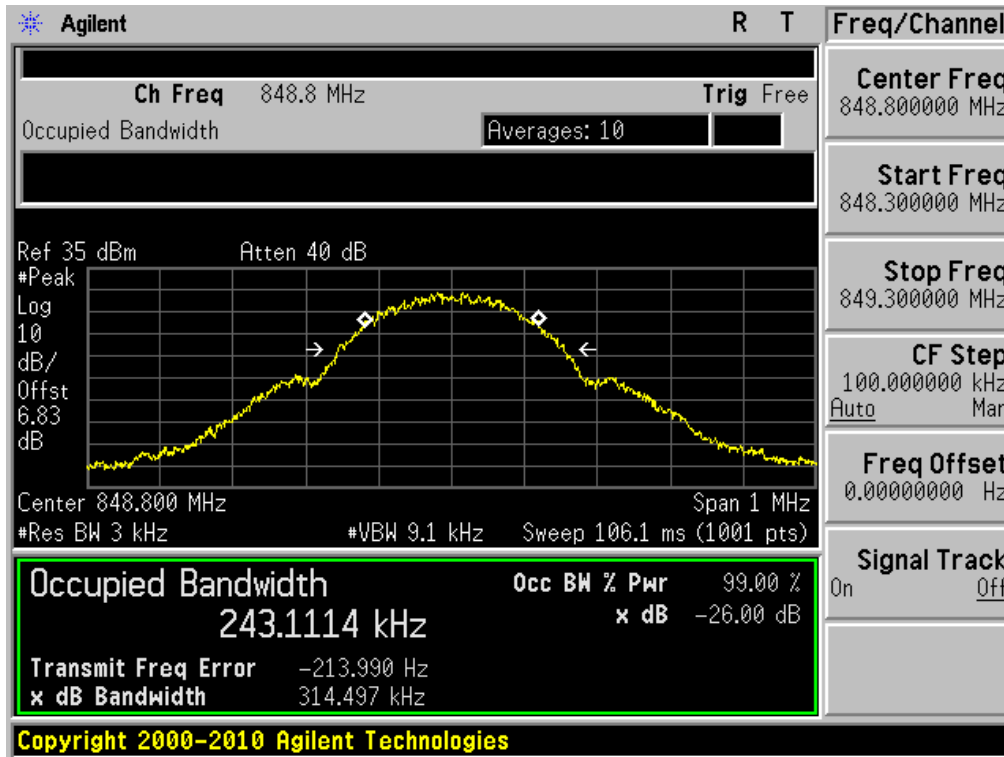

WCDMA850 & Channel: 4132

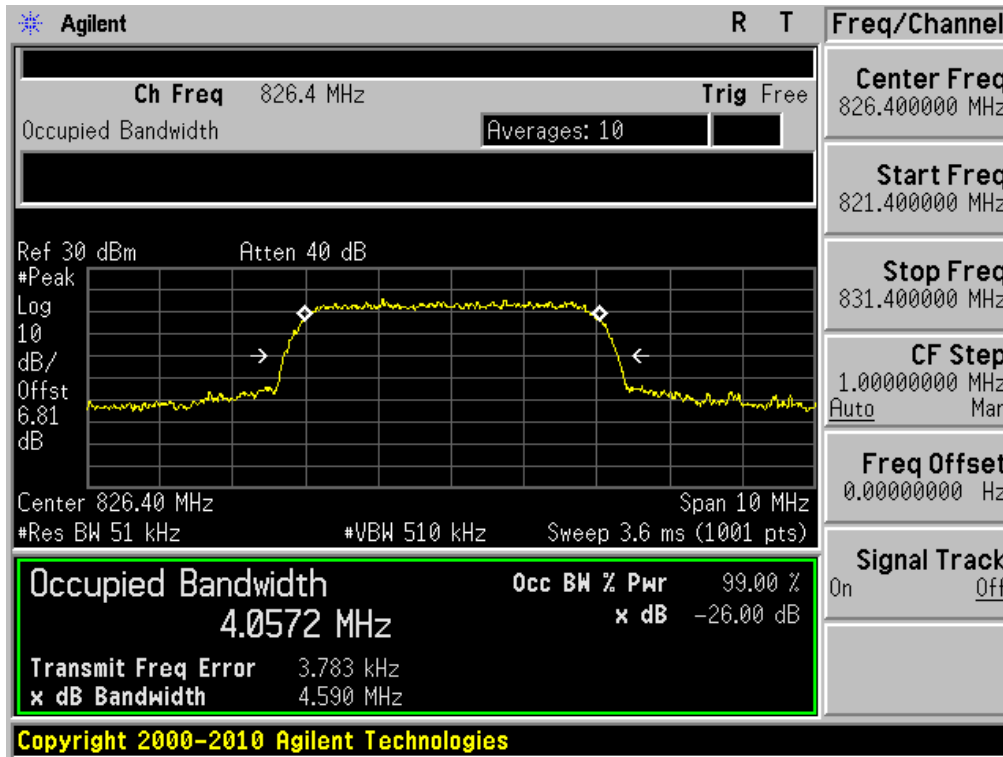

WCDMA850 & Channel: 4183

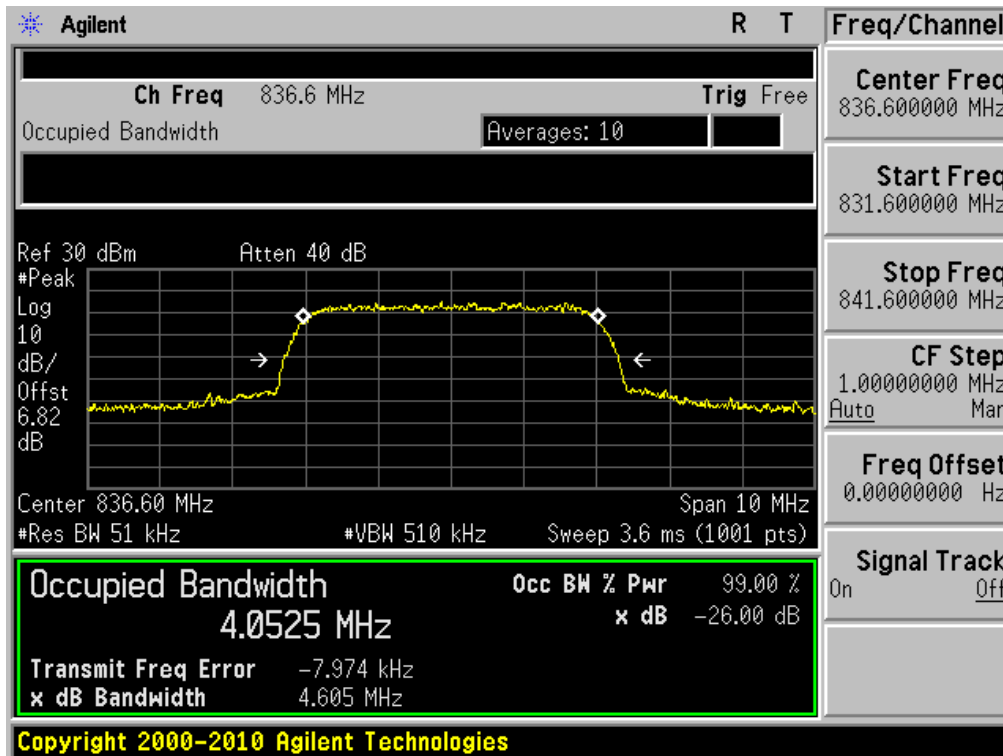

WCDMA850 & Channel: 4233

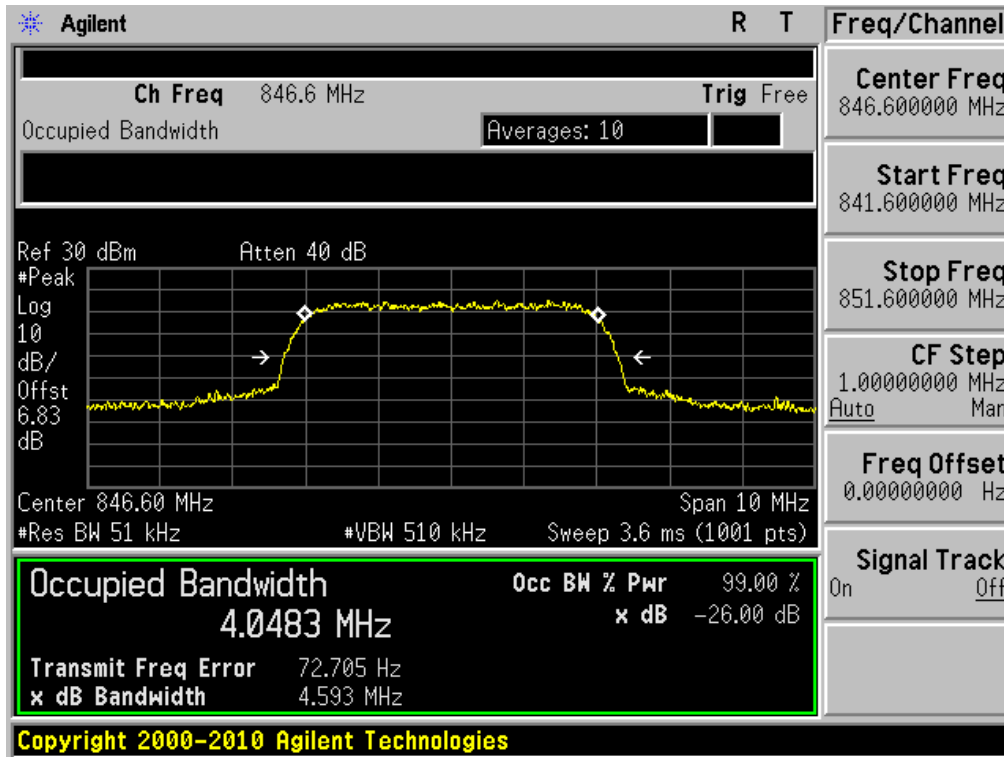

HSUPA850 & Channel: 4132

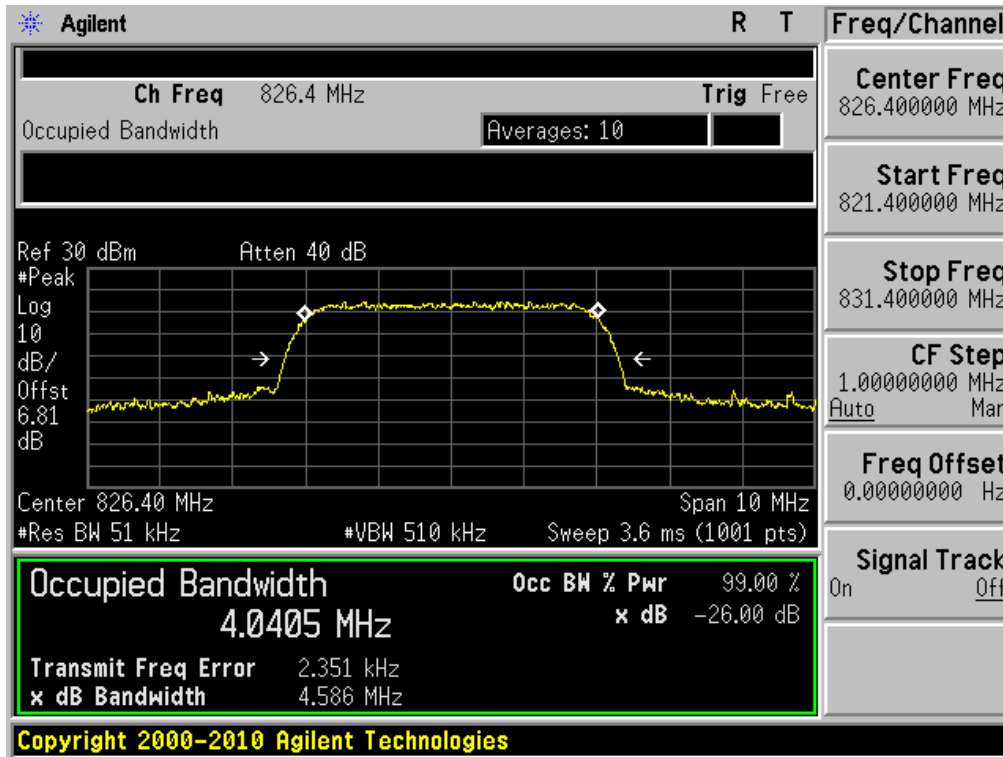

HSUPA850 & Channel: 4183

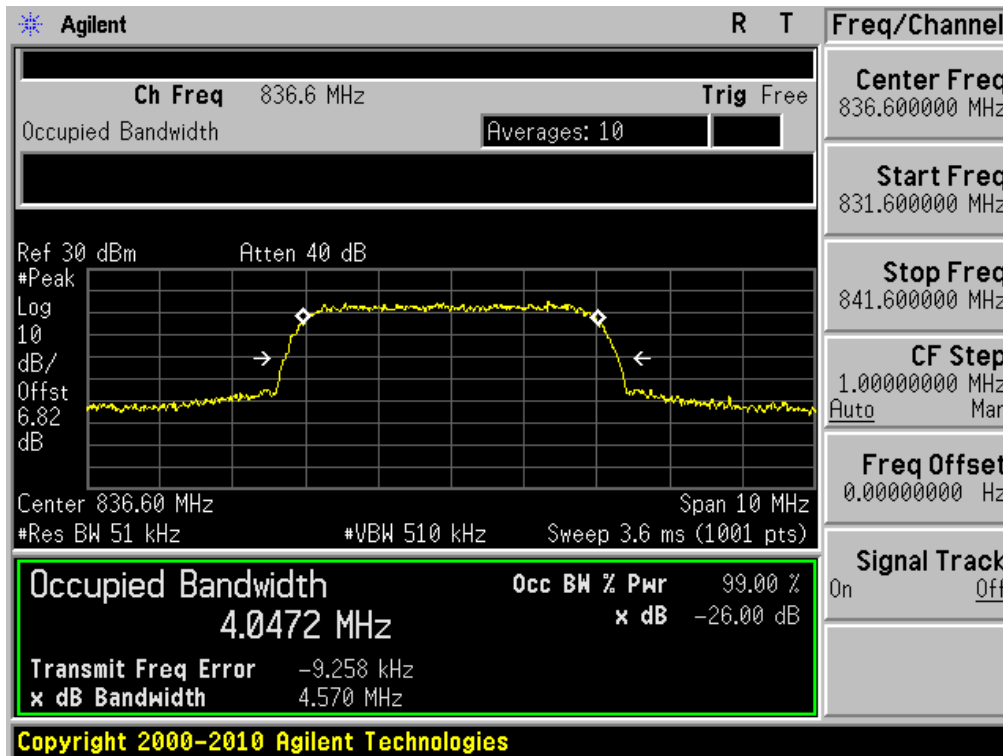

HSUPA850 & Channel: 4233

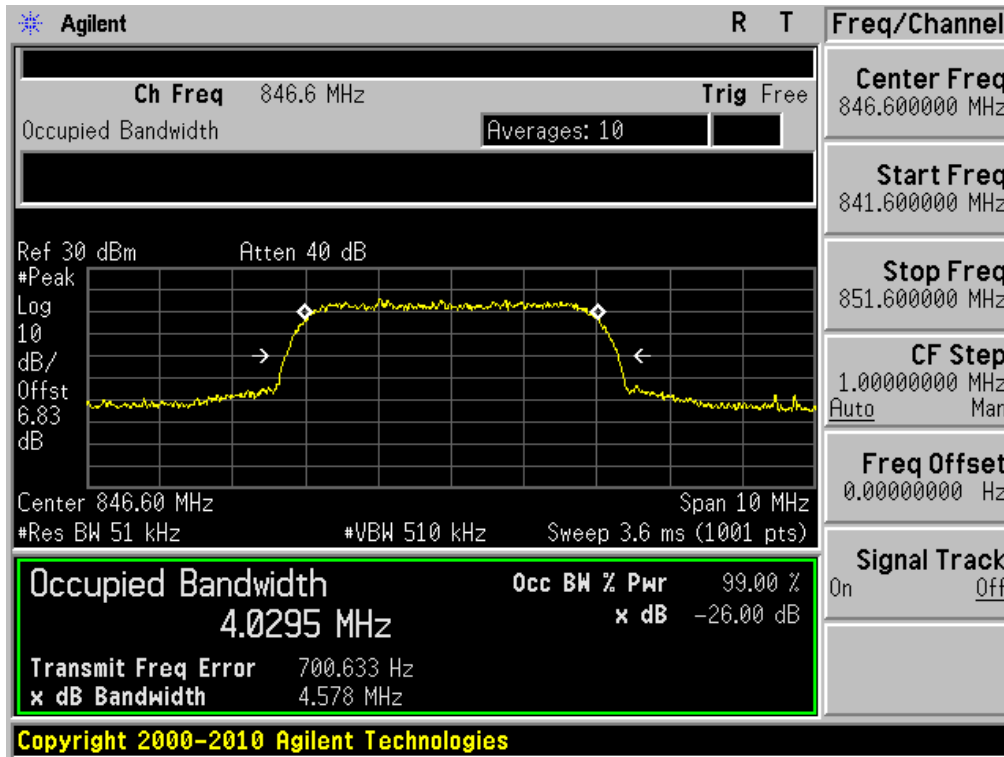

GSM 1900 & Channel: 512

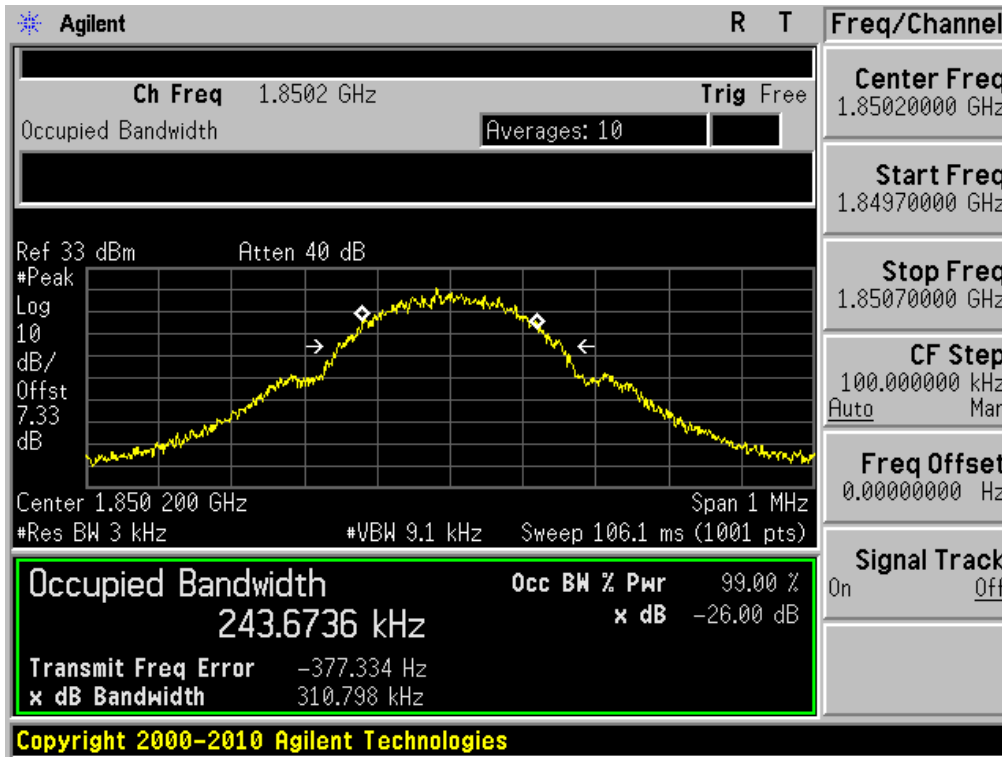

GSM 1900 & Channel: 661

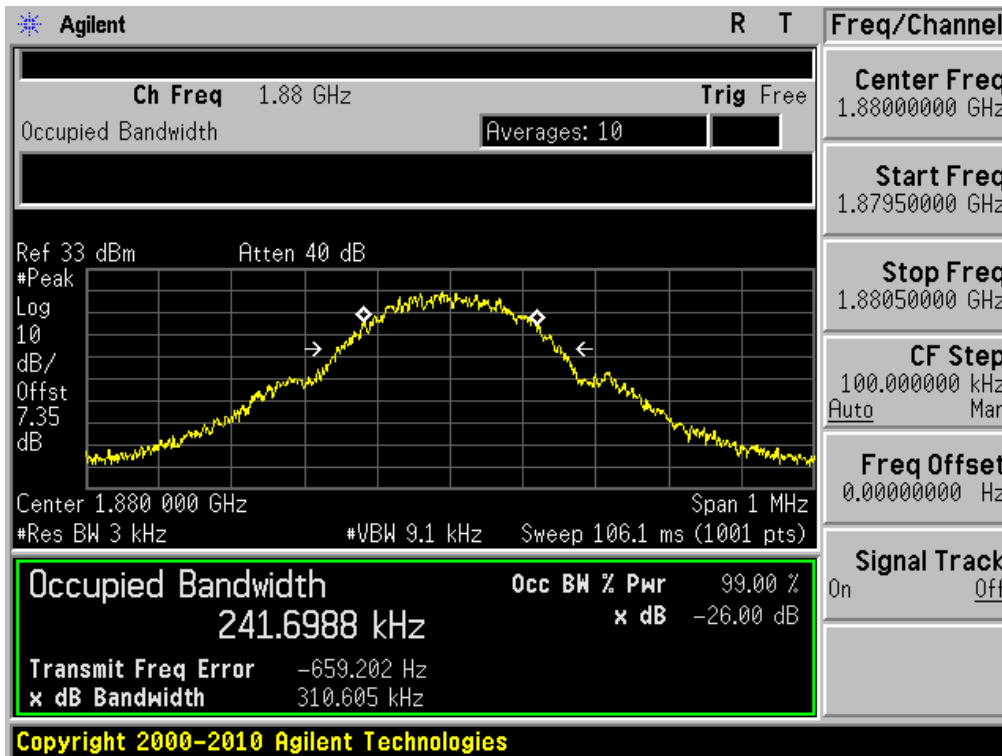

GSM 1900 & Channel: 810

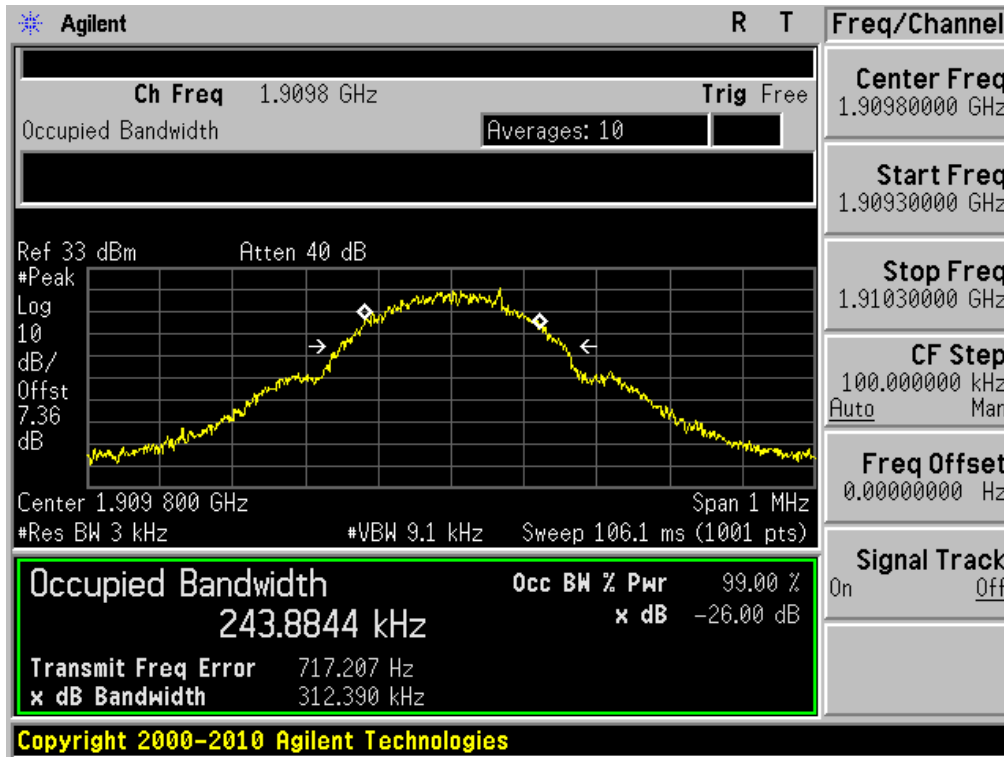

EDGE 1900 & Channel: 512

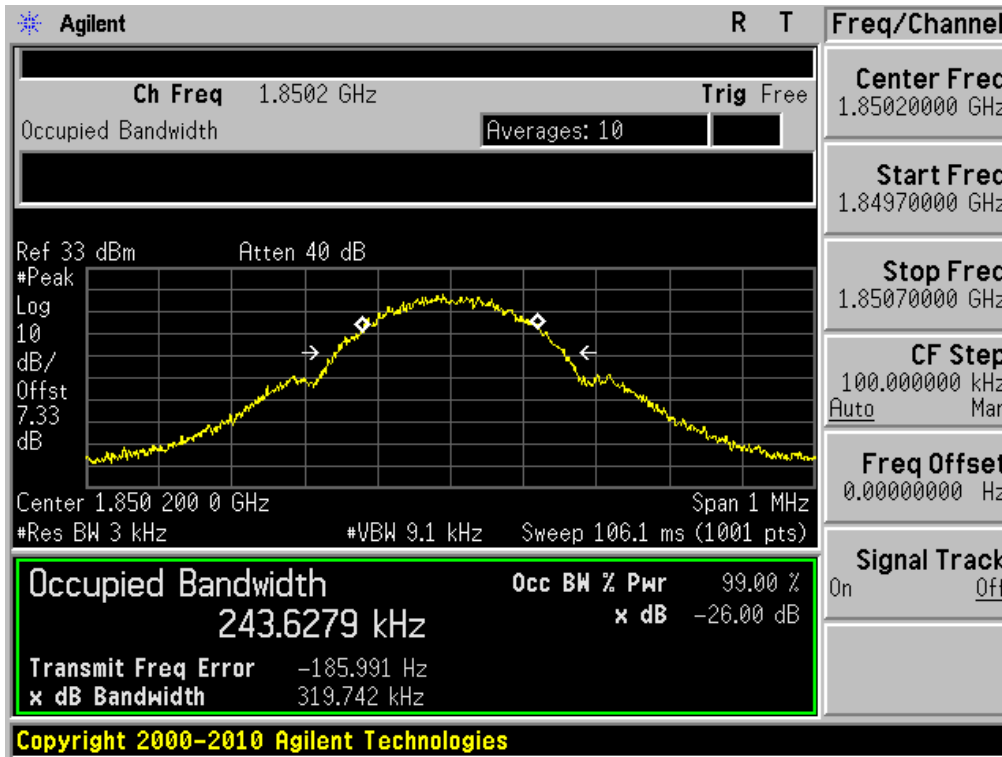

EDGE 1900 & Channel: 661

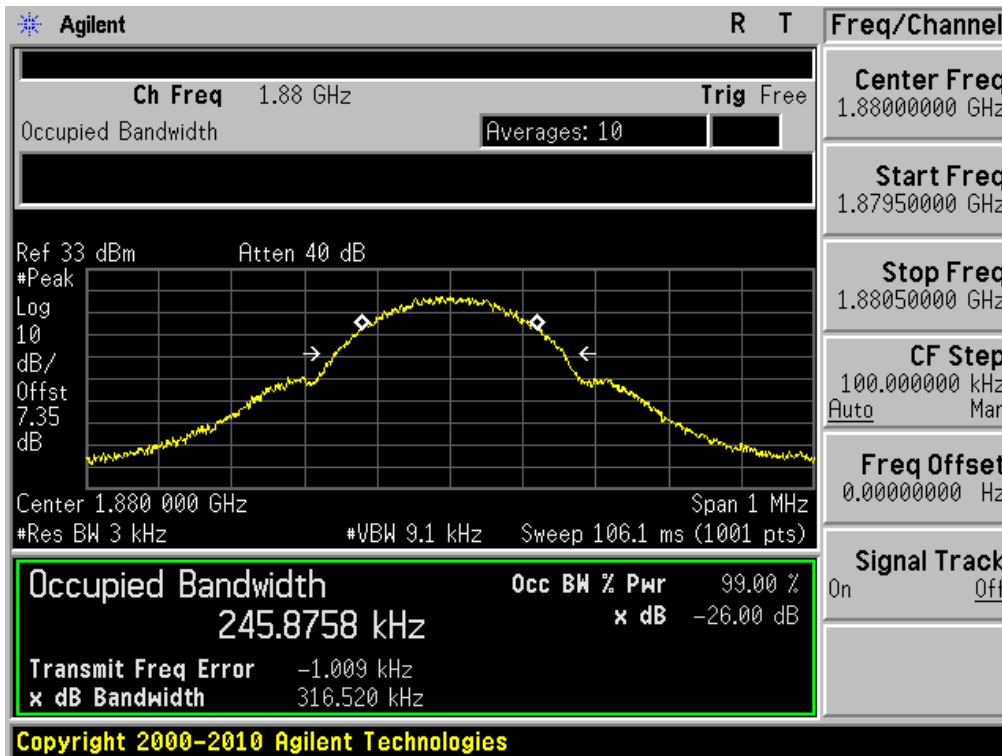

EDGE 1900 & Channel: 810

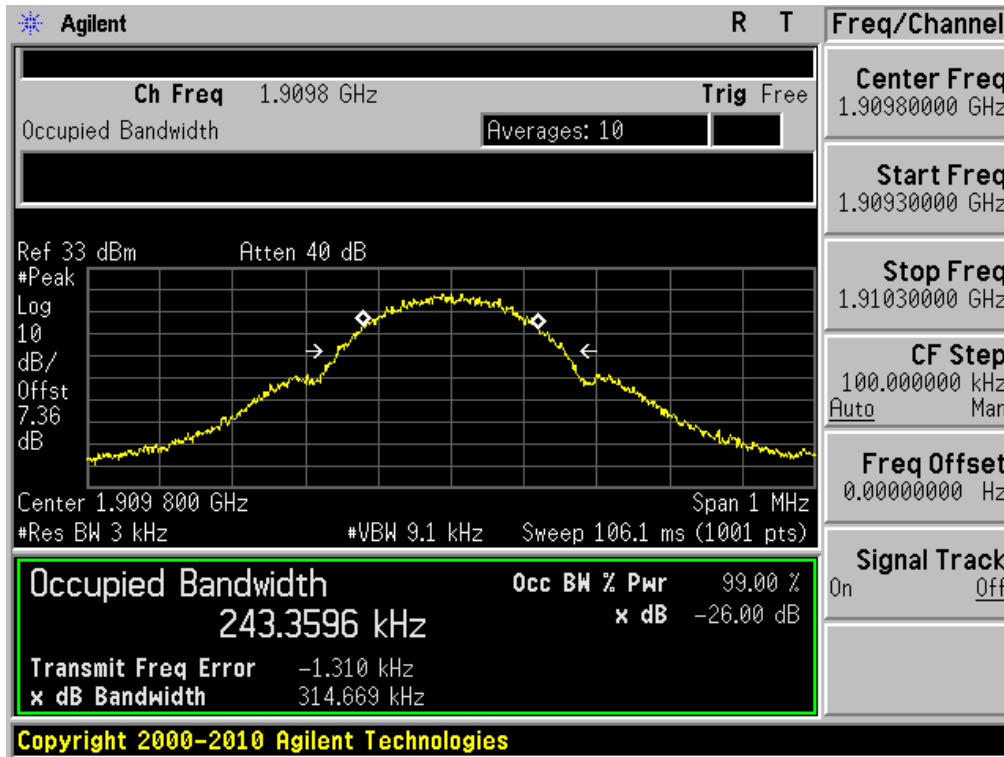

8.3 Spurious Emissions at Antenna Terminal

GSM850 & Channel: 128

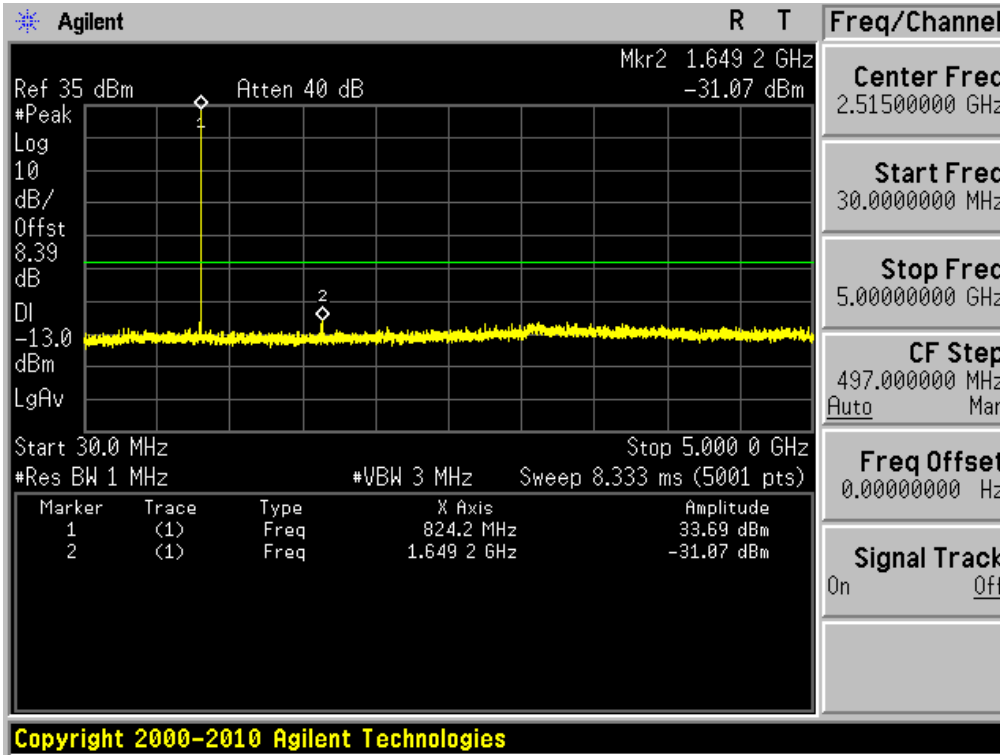

GSM850 & Channel: 128

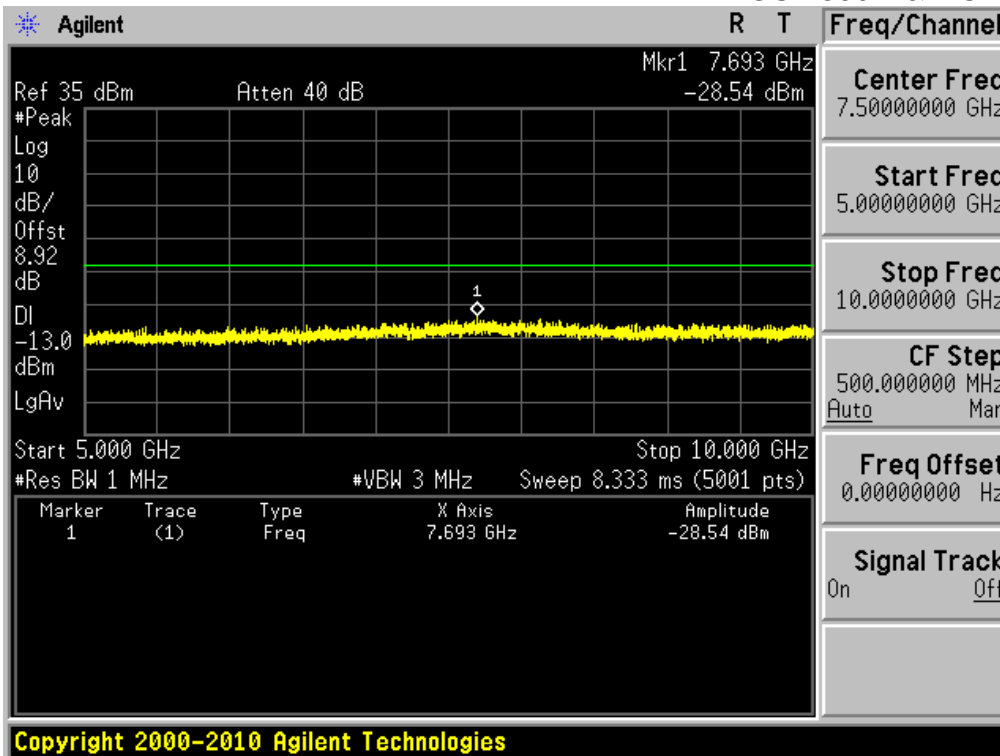

GSM850 & Channel: 190

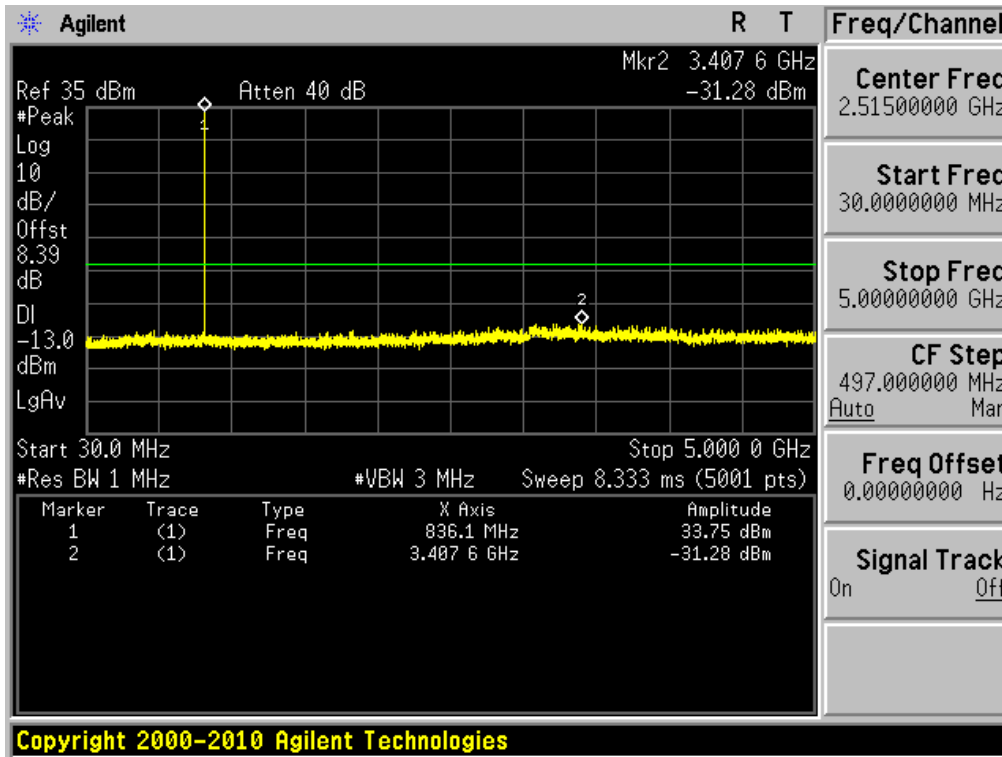

GSM850 & Channel: 190

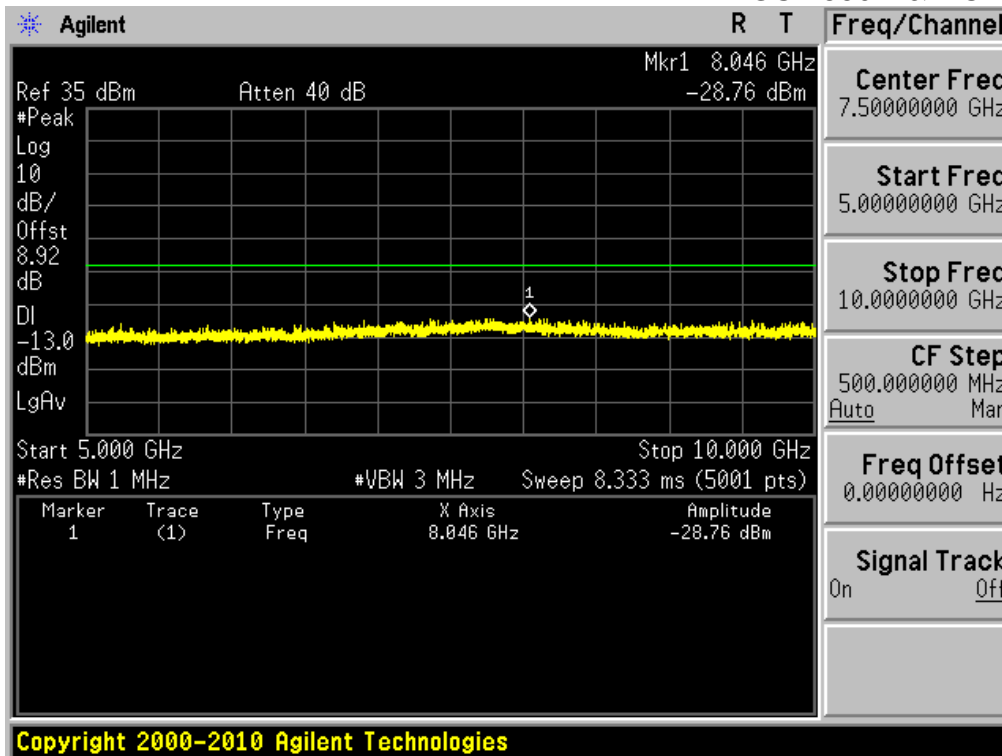

GSM850 & Channel: 251

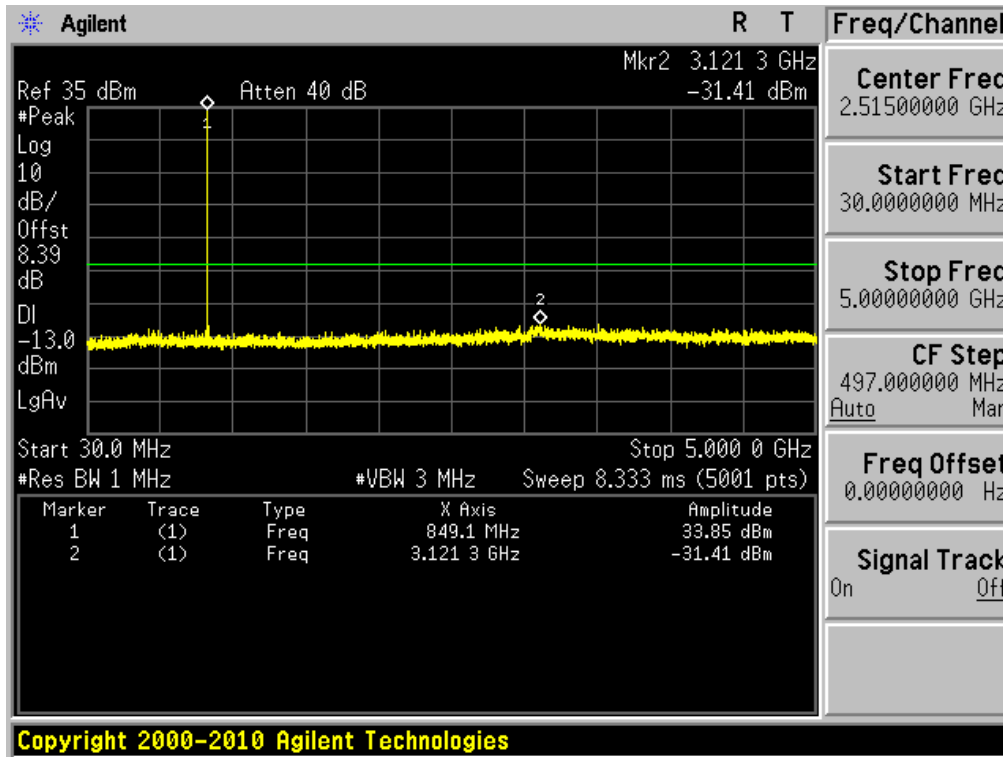

GSM850 & Channel: 251

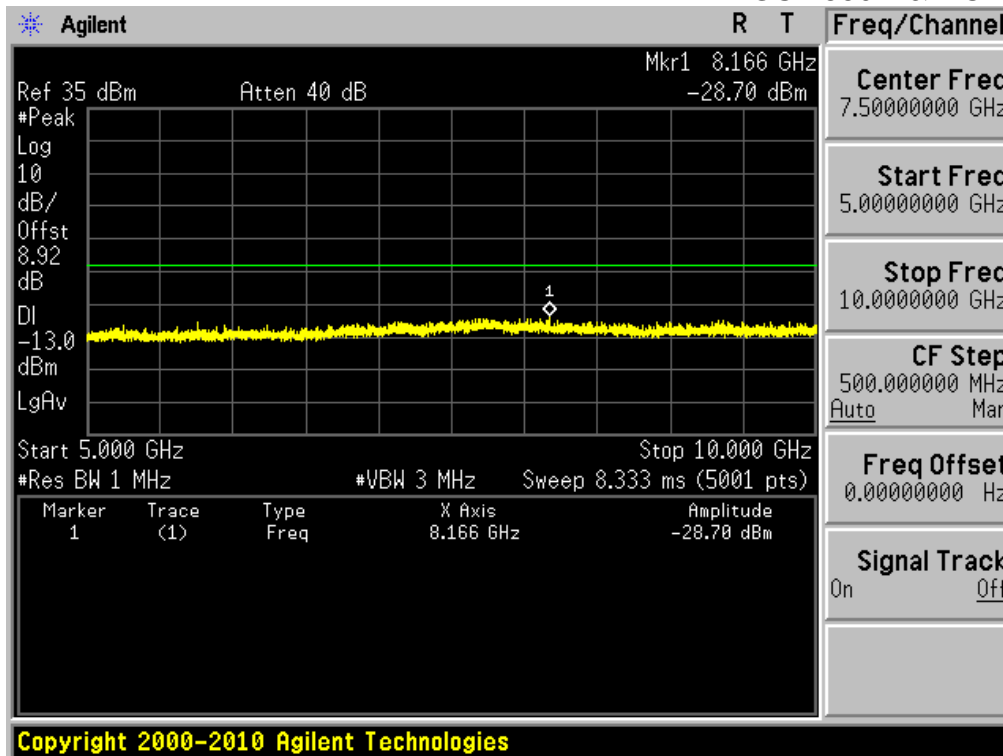

WCDMA850 & Channel: 4132

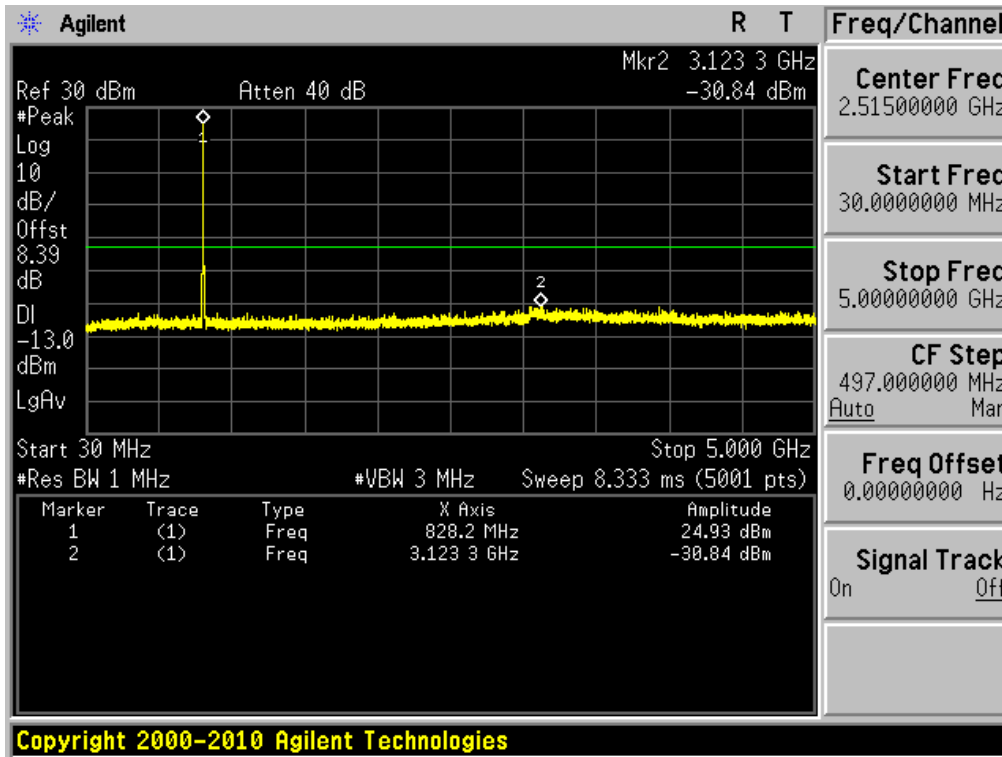

Copyright 2000-2010 Agilent Technologies

WCDMA850 & Channel: 4132

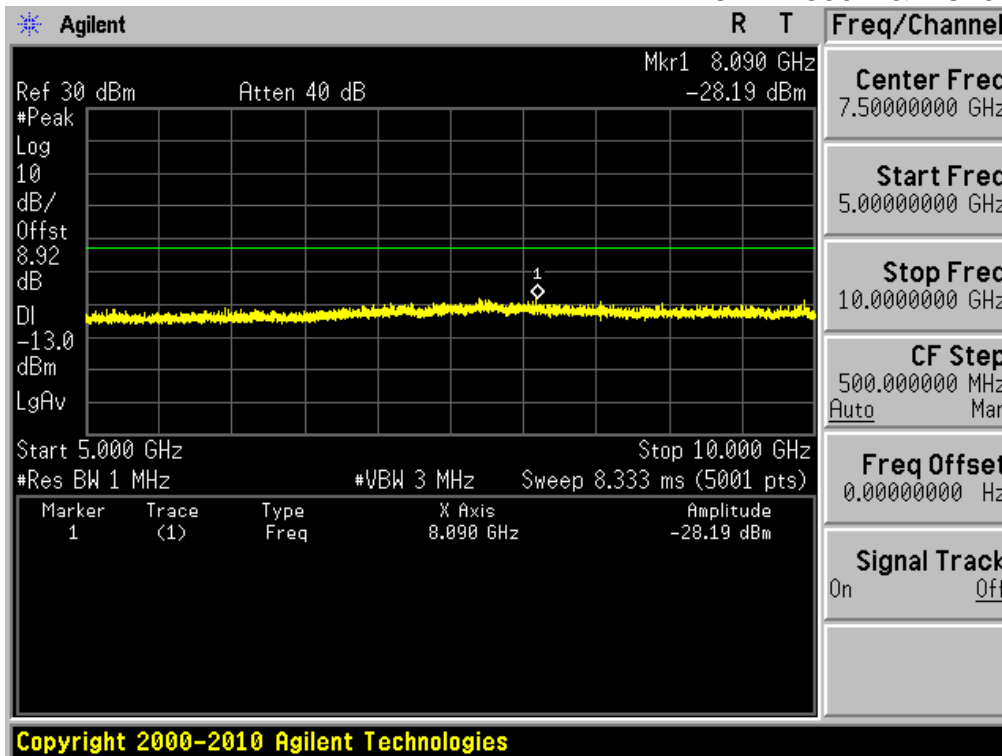

Copyright 2000-2010 Agilent Technologies

WCDMA850 & Channel: 4183

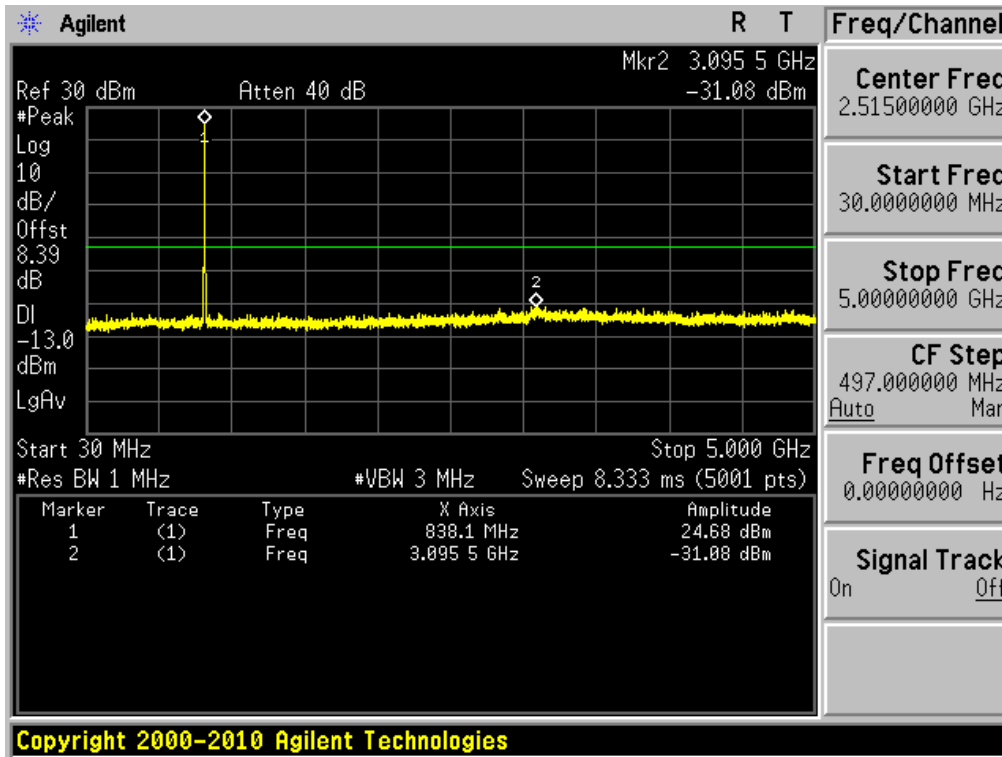

WCDMA850 & Channel: 4183

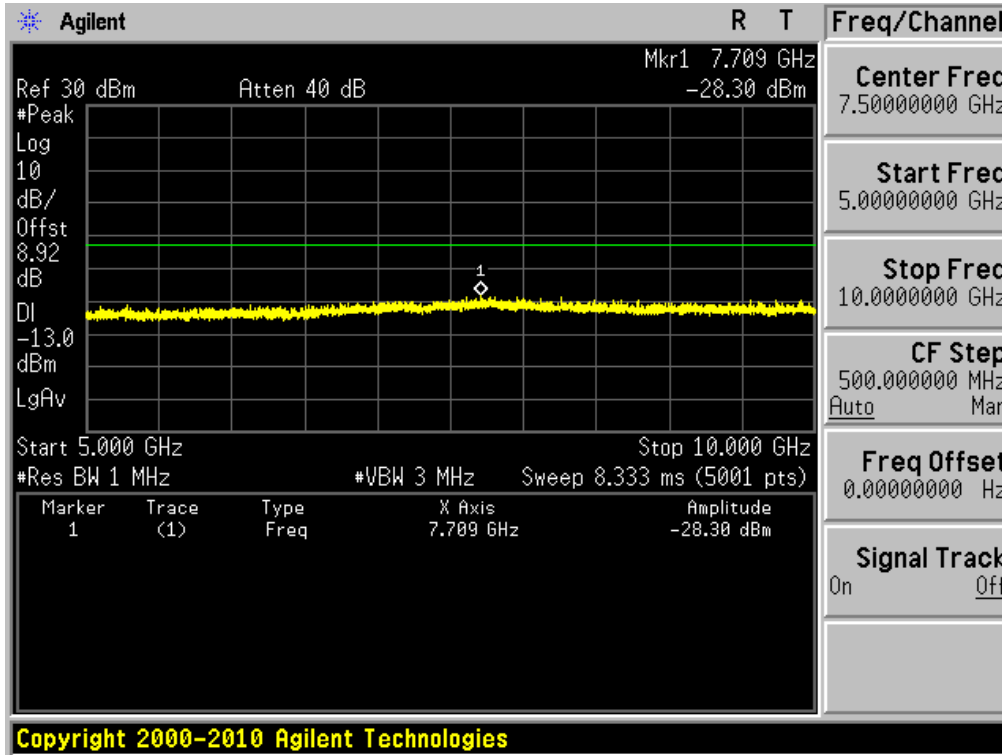

WCDMA850 & Channel: 4233

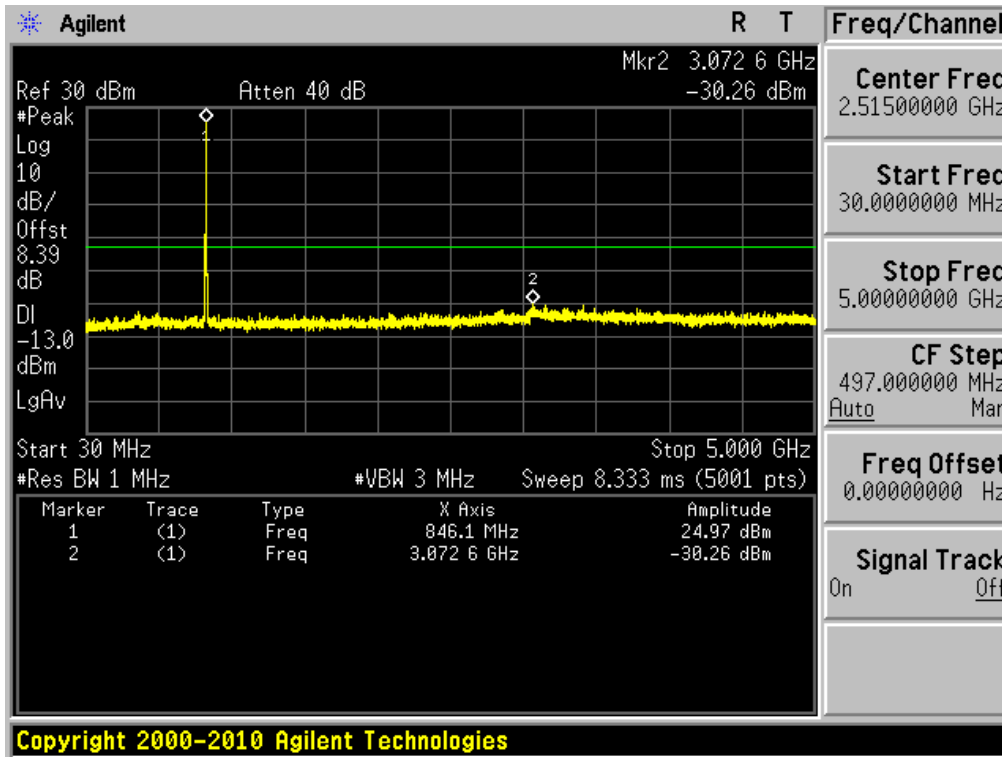

WCDMA850 & Channel: 4233

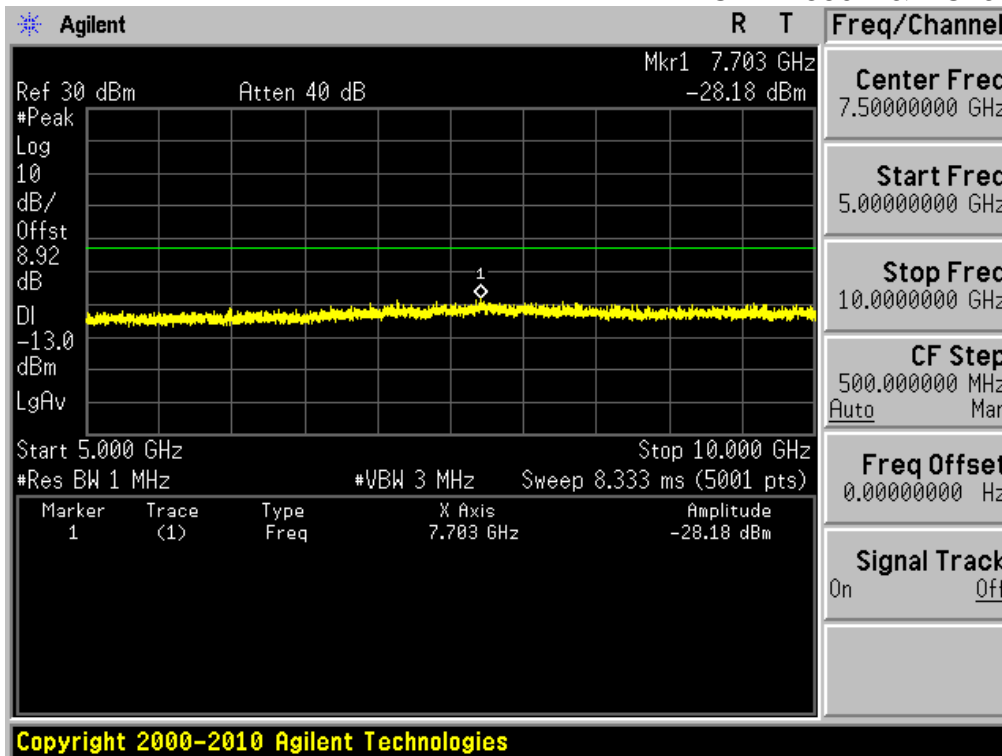

HSUPA850 & Channel: 4132

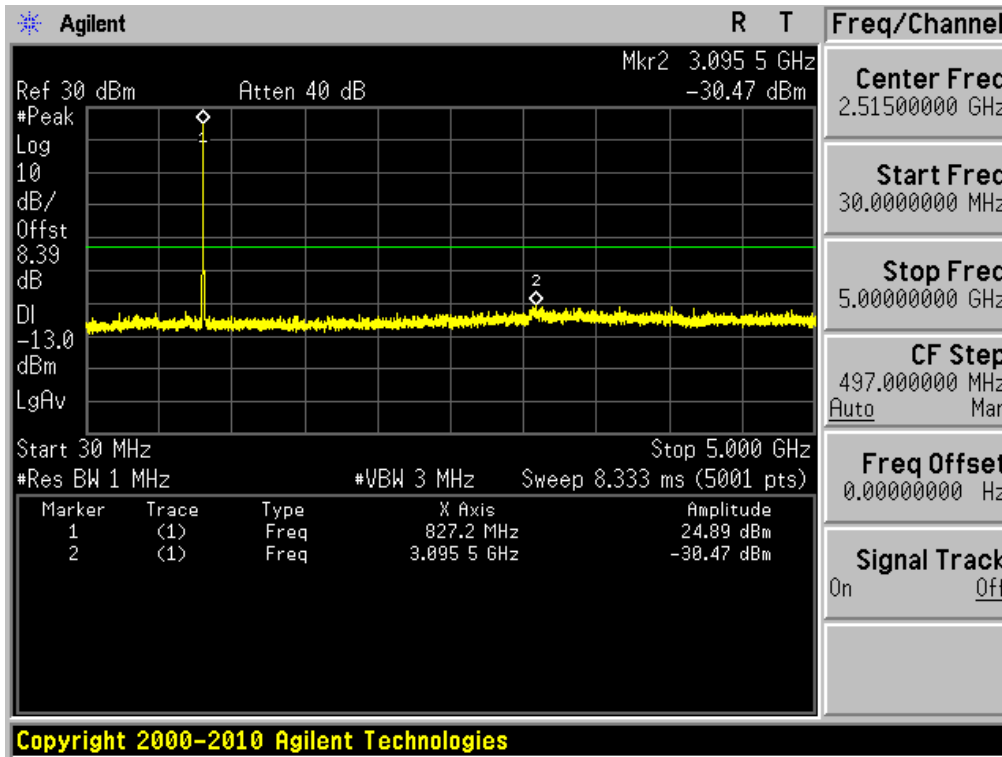

HSUPA850 & Channel: 4132

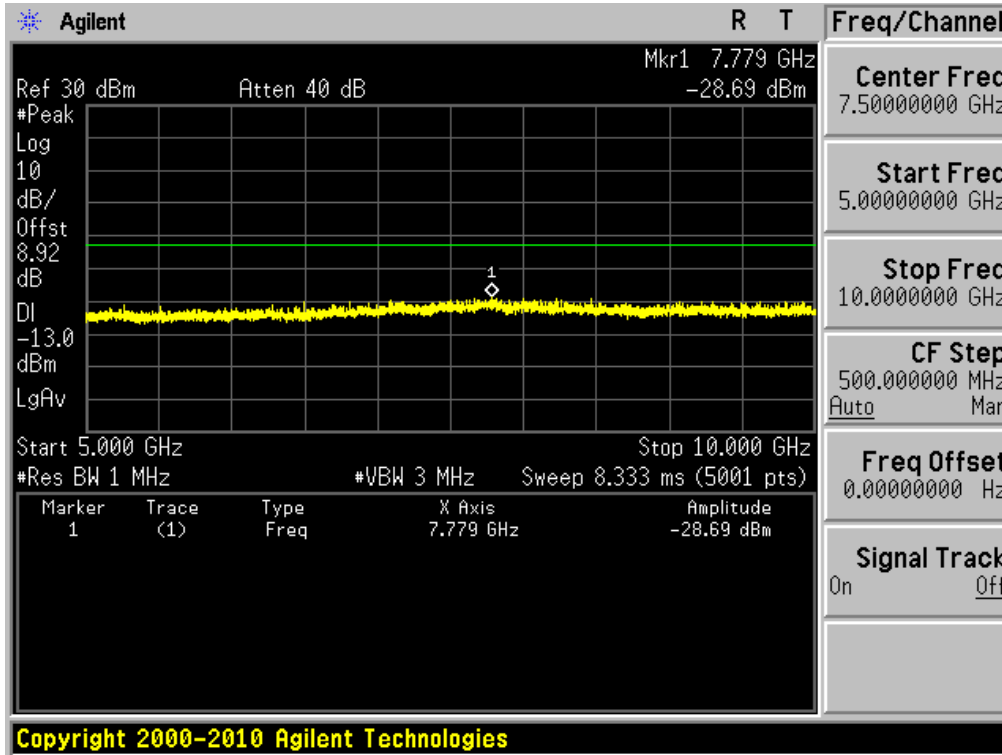

HSUPA850 & Channel: 4183

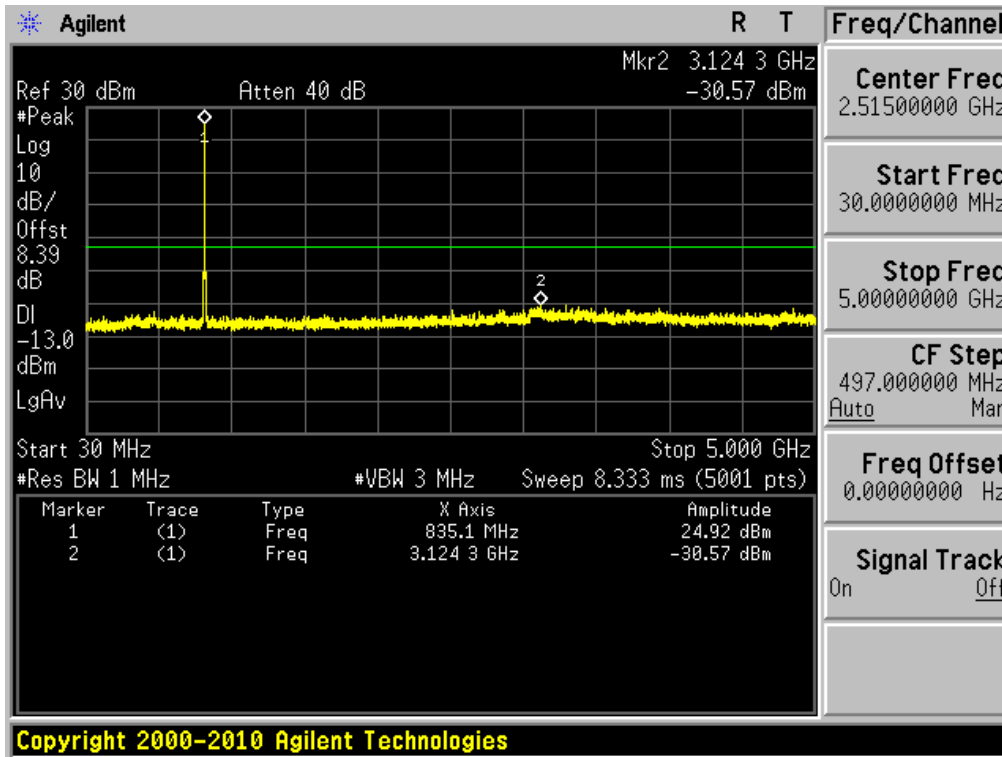

HSUPA850 & Channel: 4183

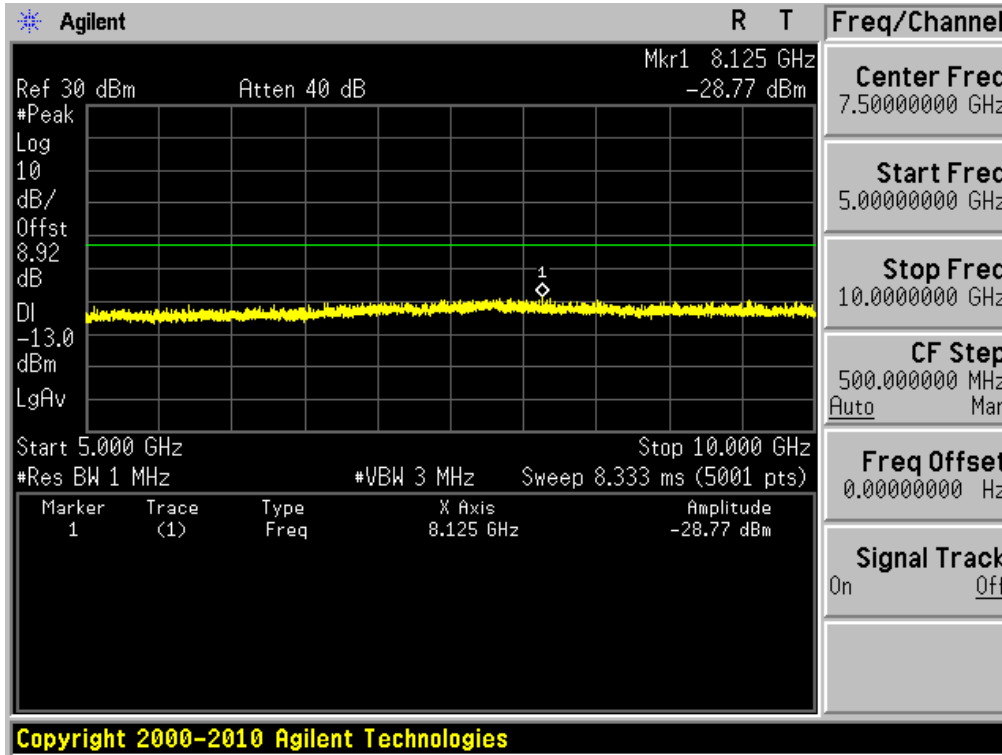

HSUPA850 & Channel: 4233

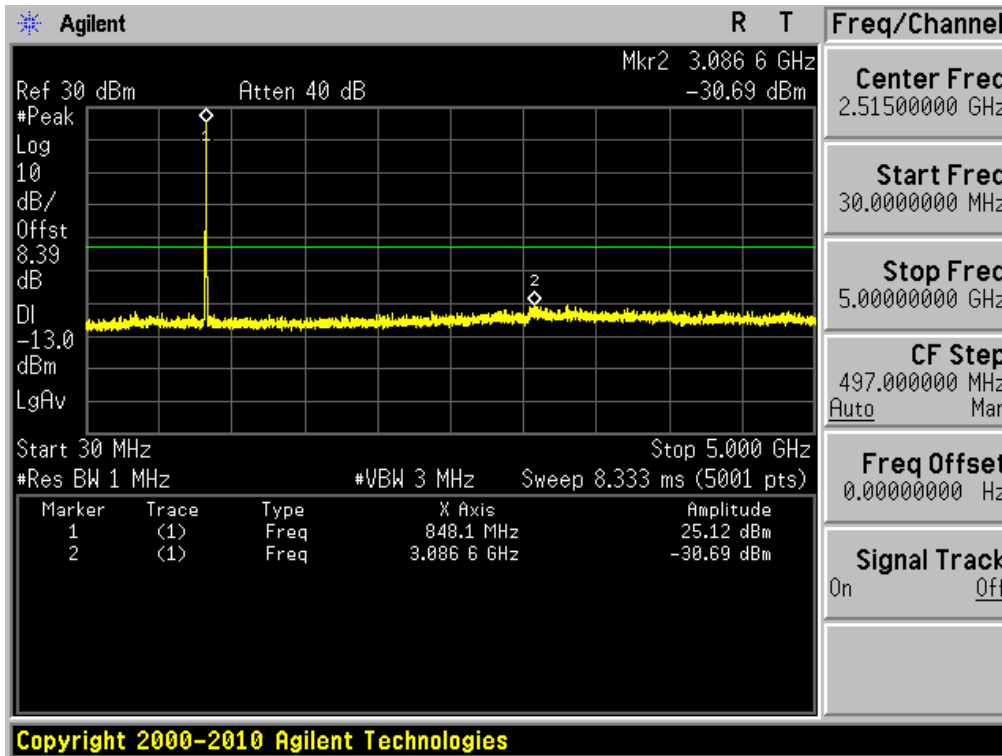

HSUPA850 & Channel: 4233

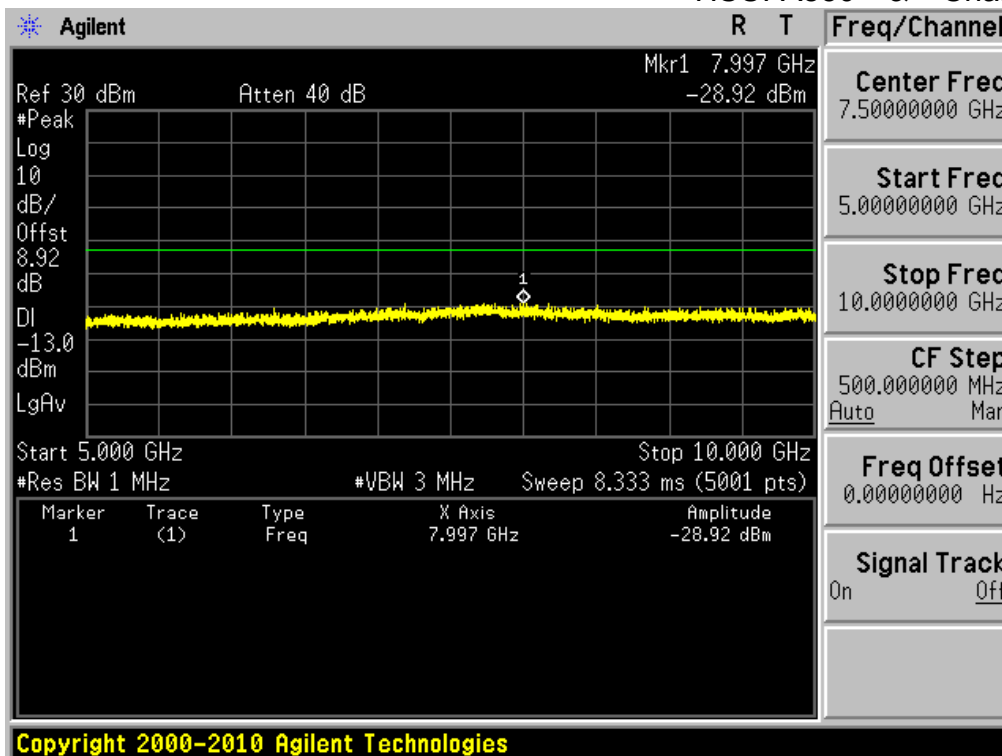

PCS1900 & Channel: 512

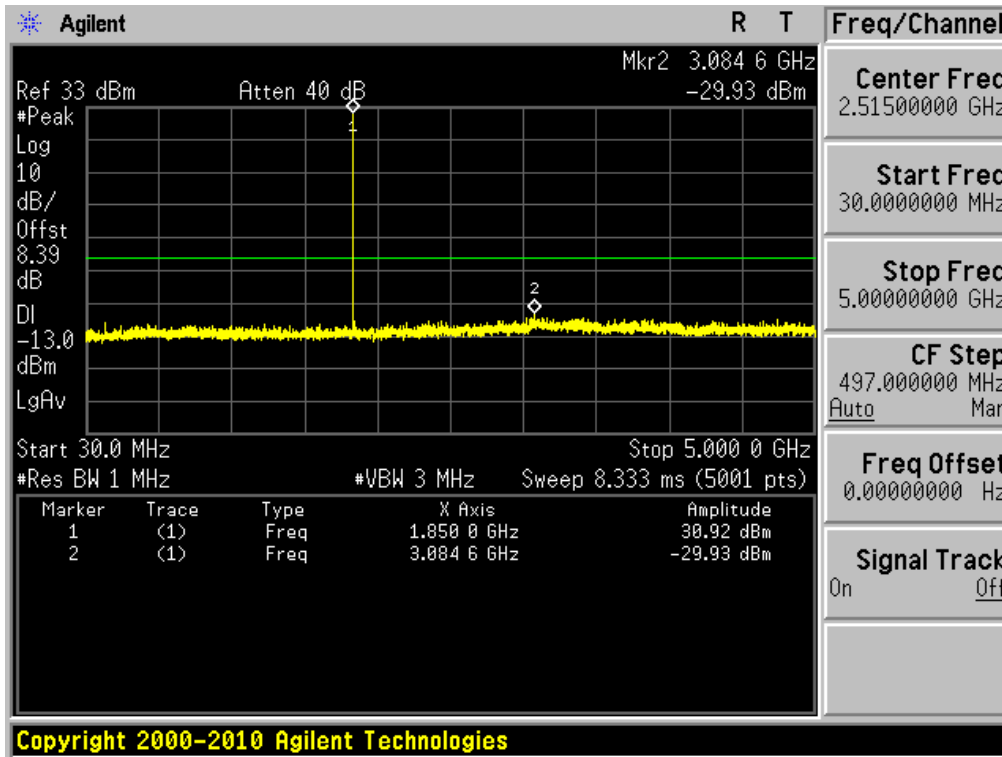

PCS1900 & Channel: 512

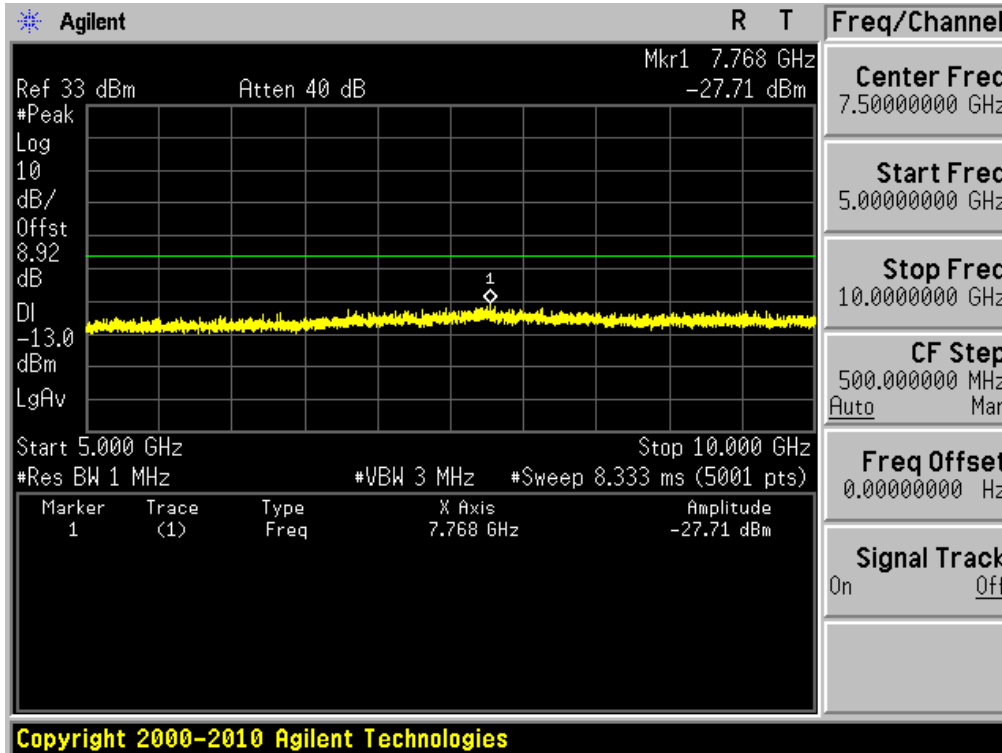

PCS1900 & Channel: 512

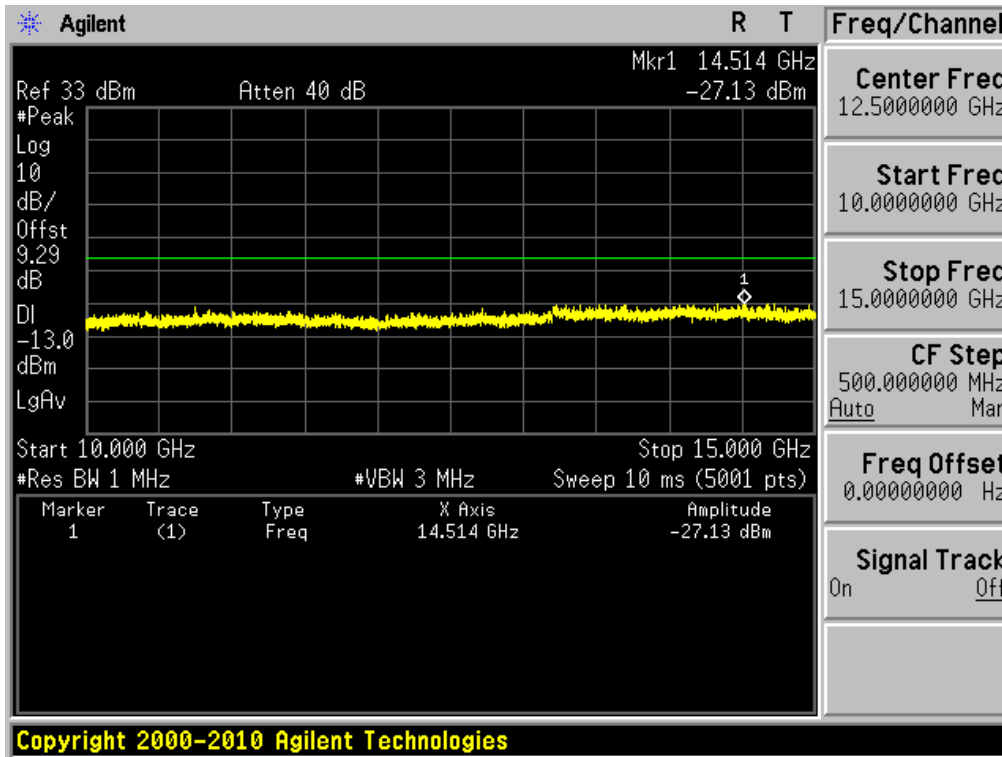

PCS1900 & Channel: 512

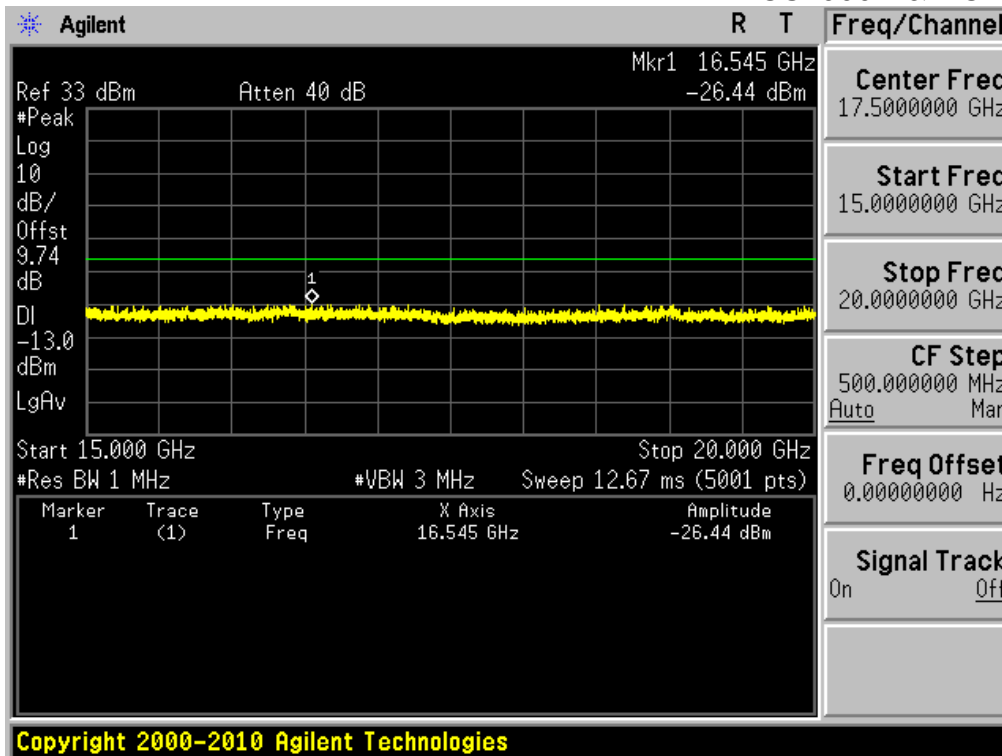

PCS1900 & Channel: 661

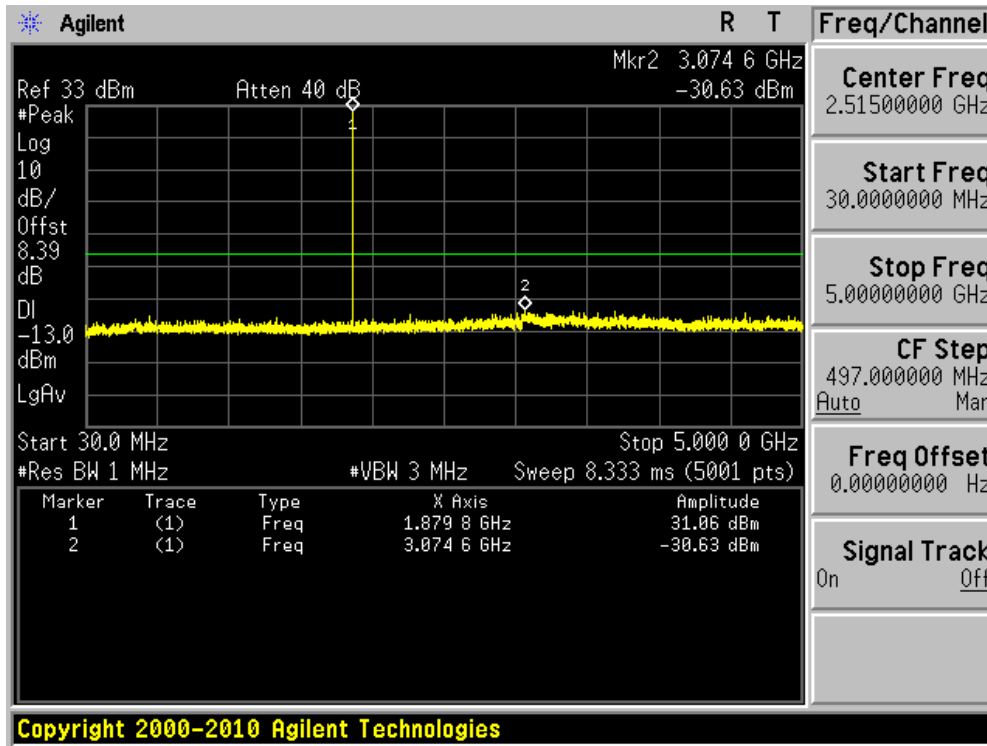

PCS1900 & Channel: 661

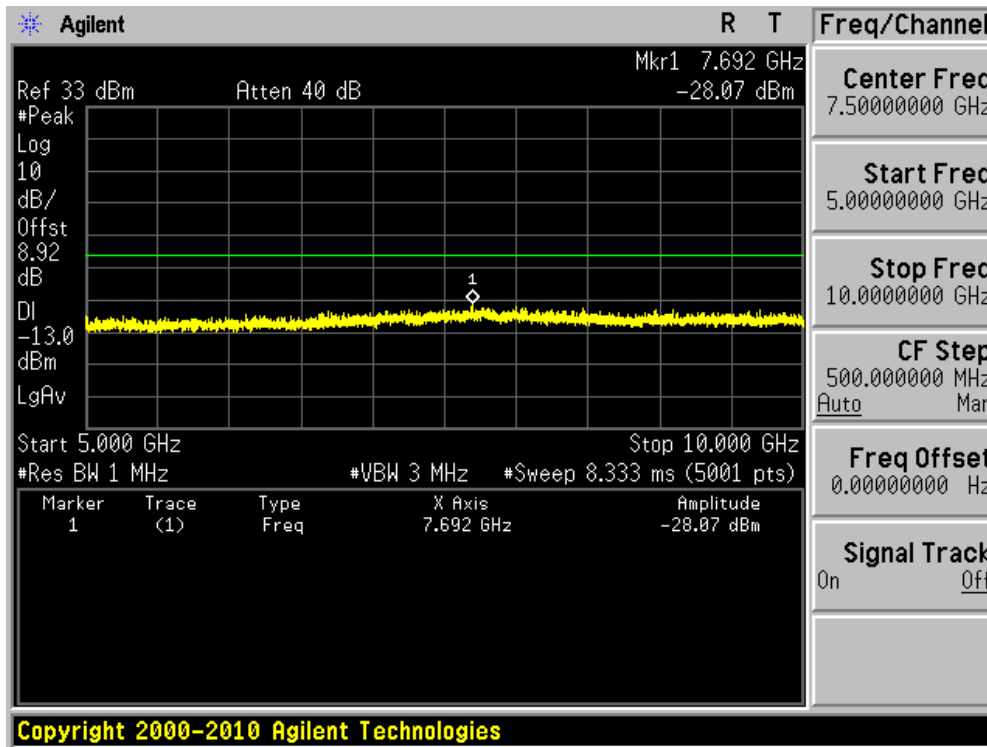

PCS1900 & Channel: 661

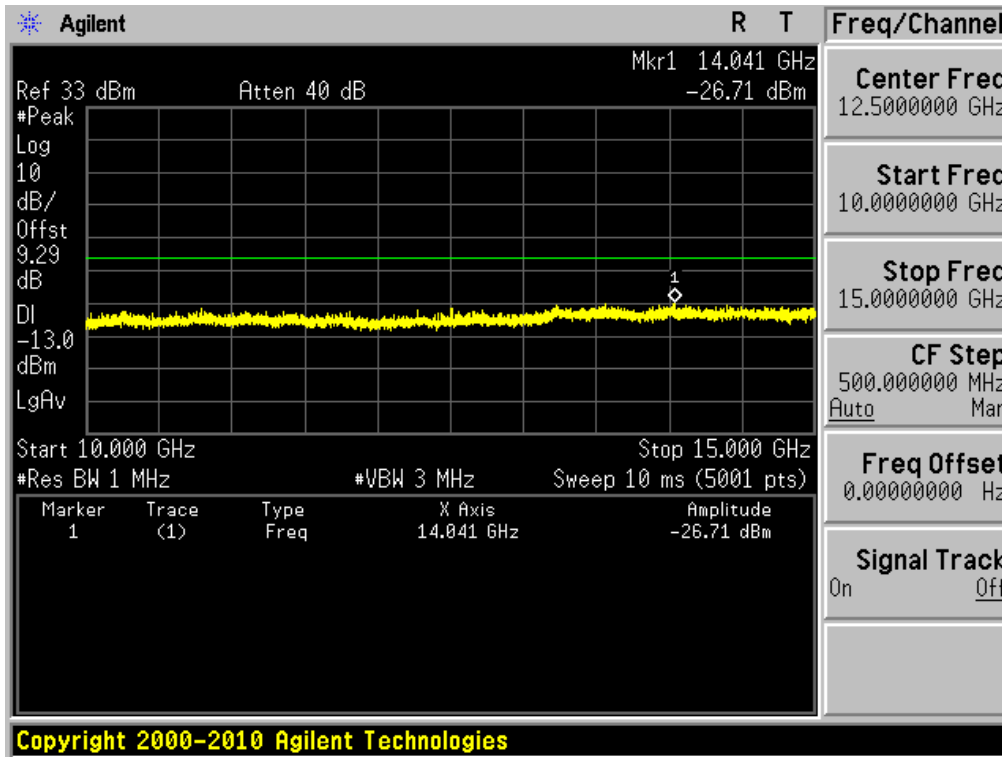

PCS1900 & Channel: 661

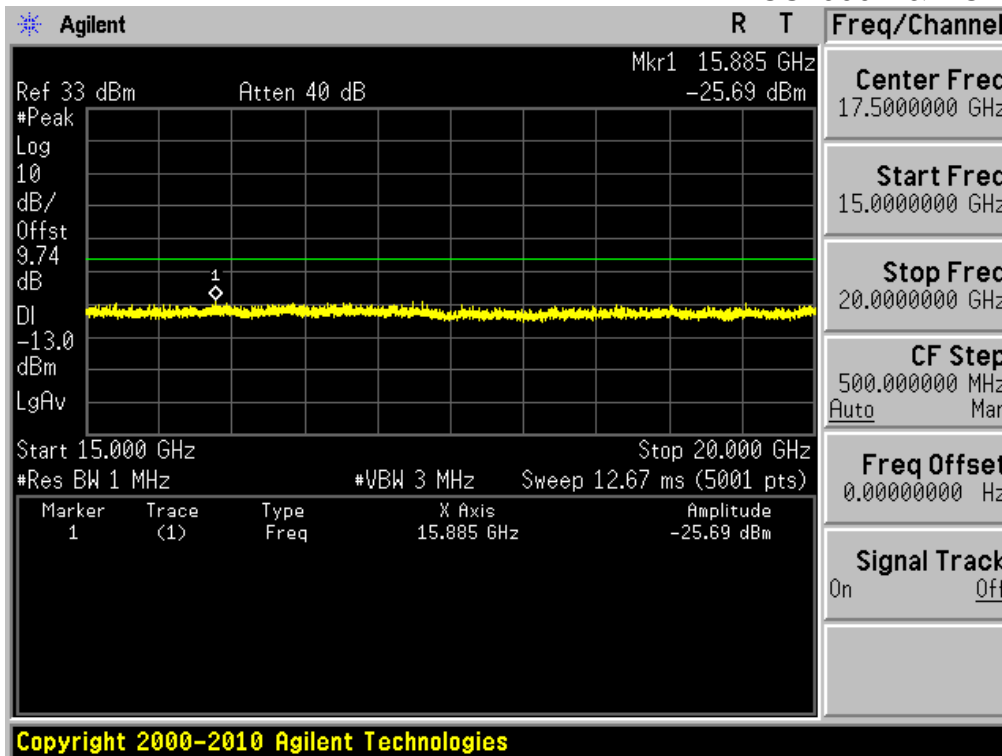

PCS1900 & Channel: 810

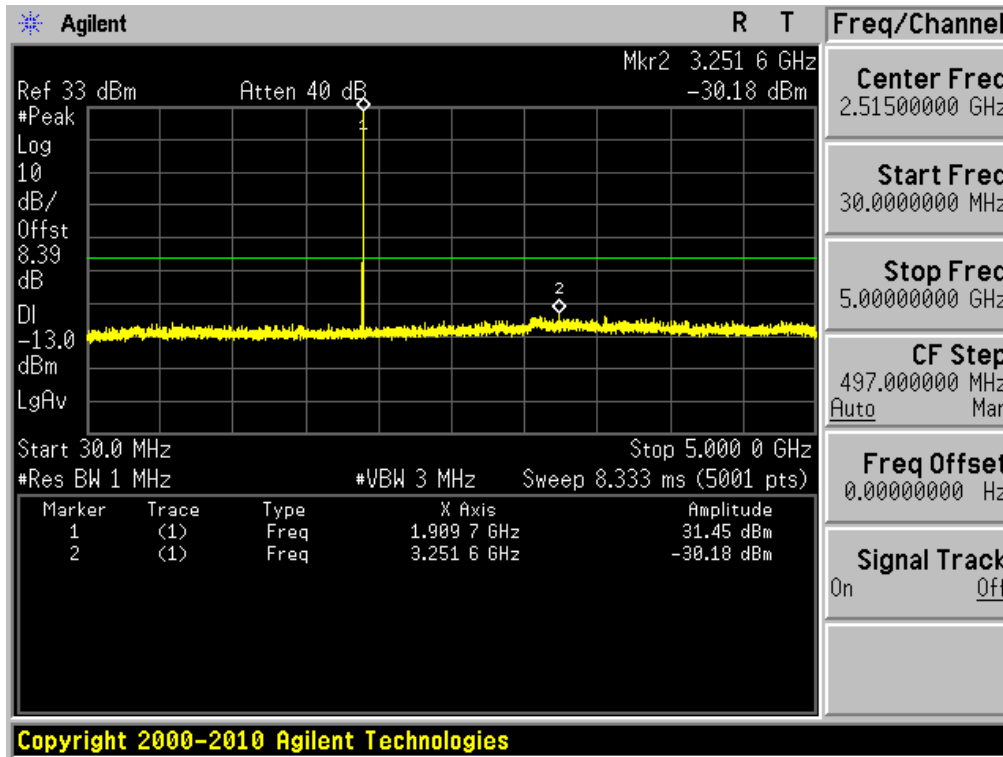

PCS1900 & Channel: 810

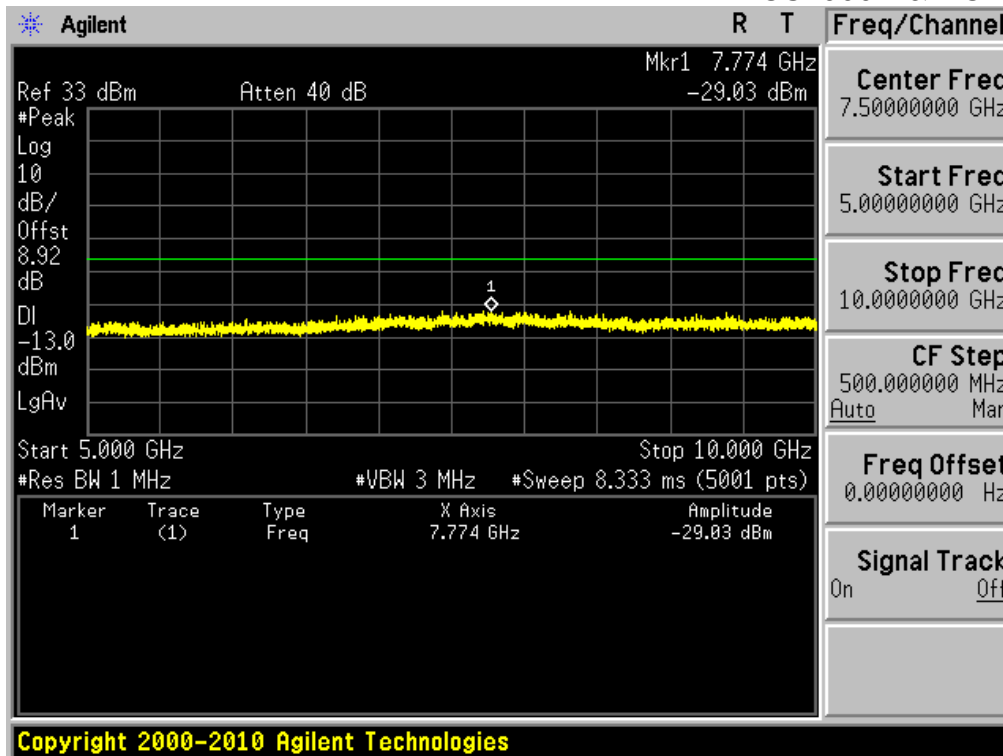

PCS1900 & Channel: 810

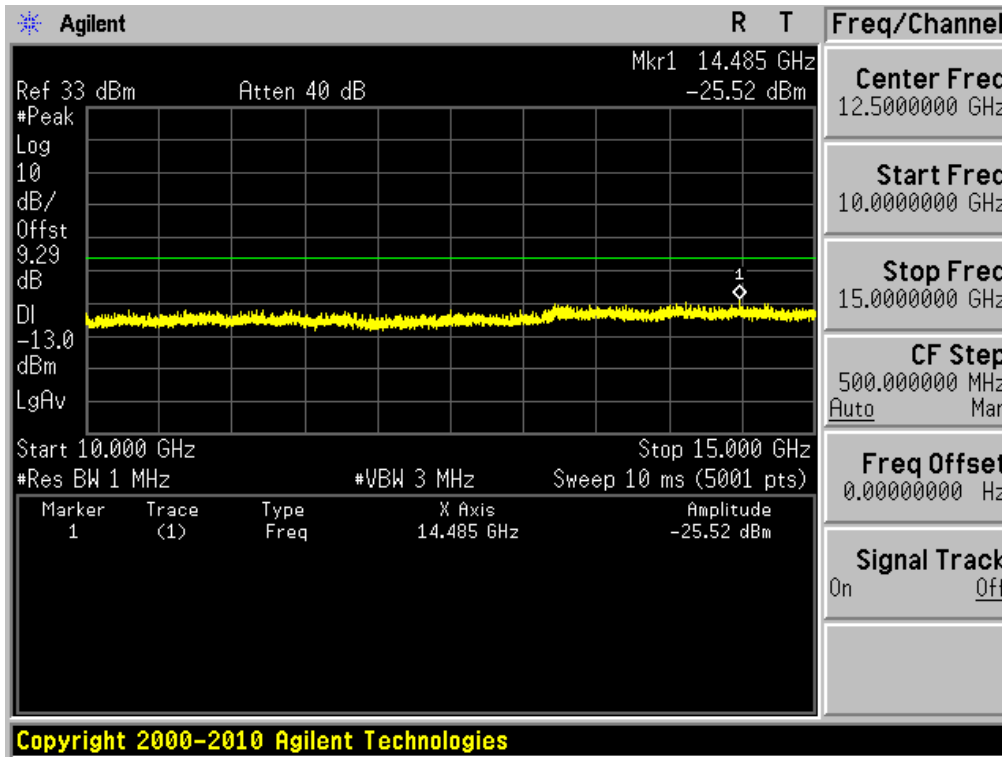

PCS1900 & Channel: 810

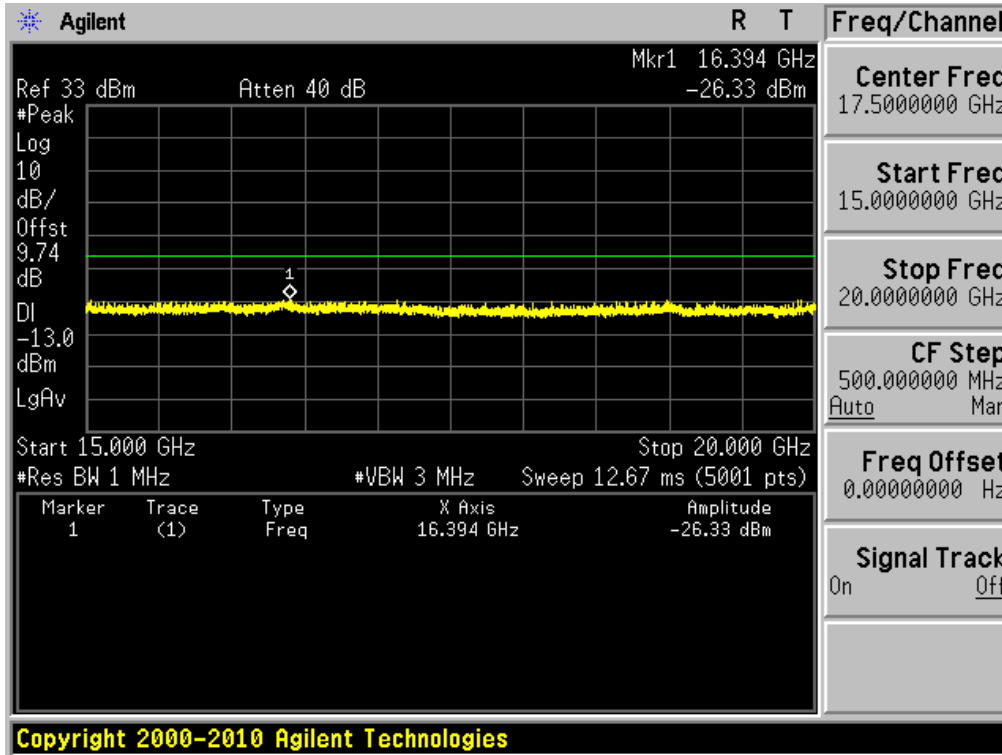

8.4 Band Edge

GSM850 & Channel: 128

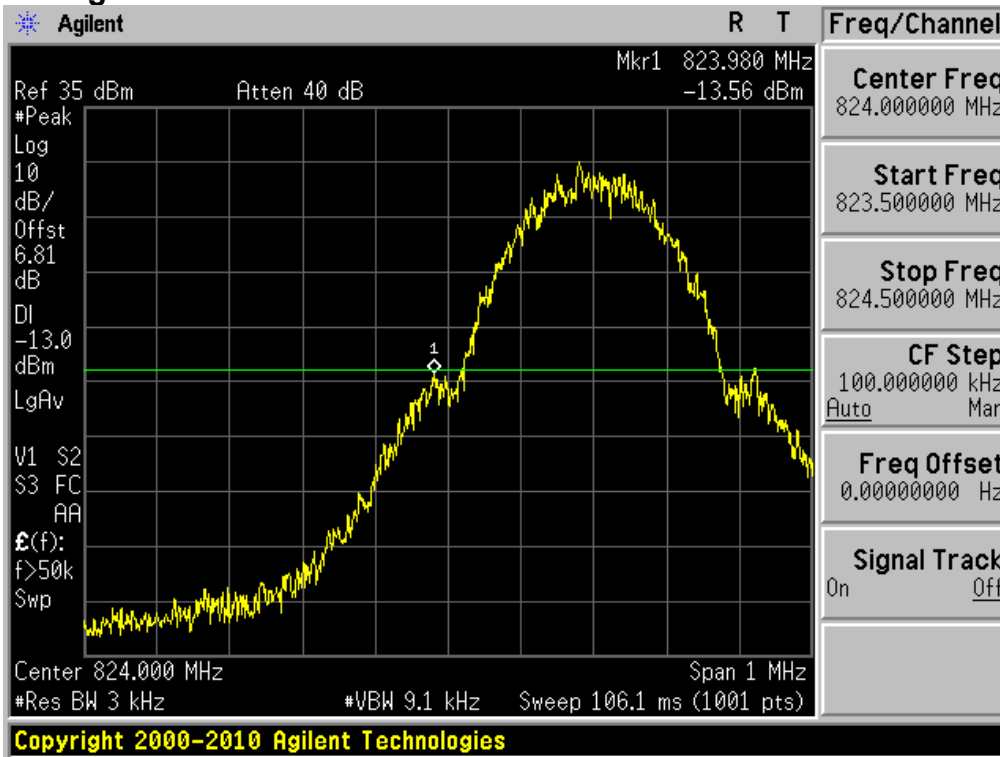

GSM850 & Channel: 251

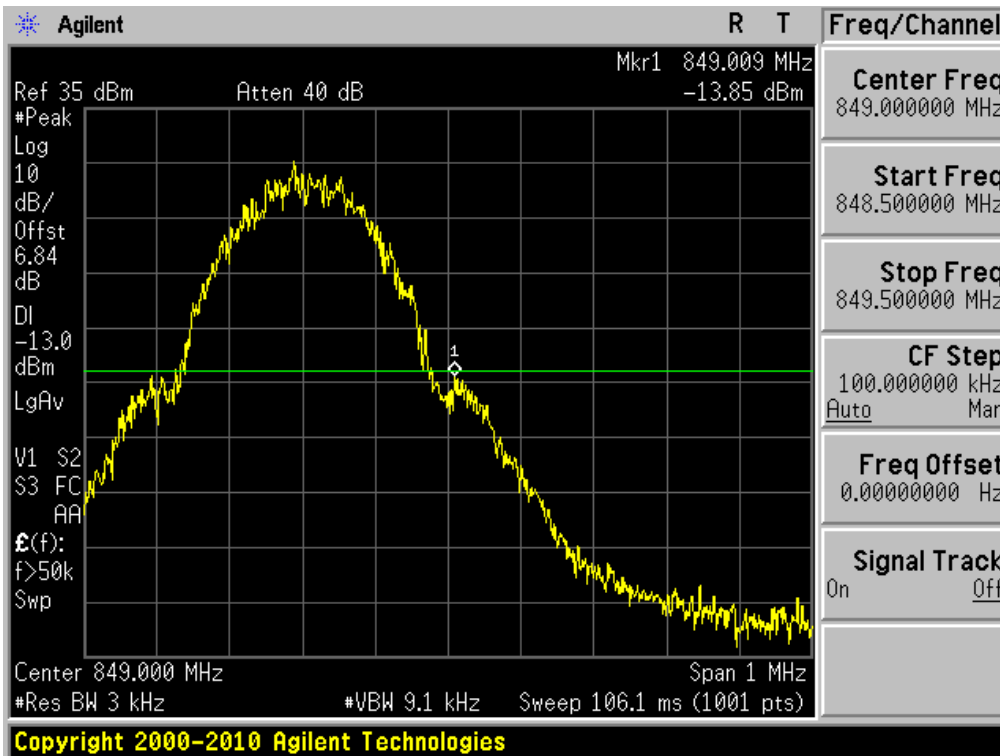

WCDMA850 & Channel: 4132

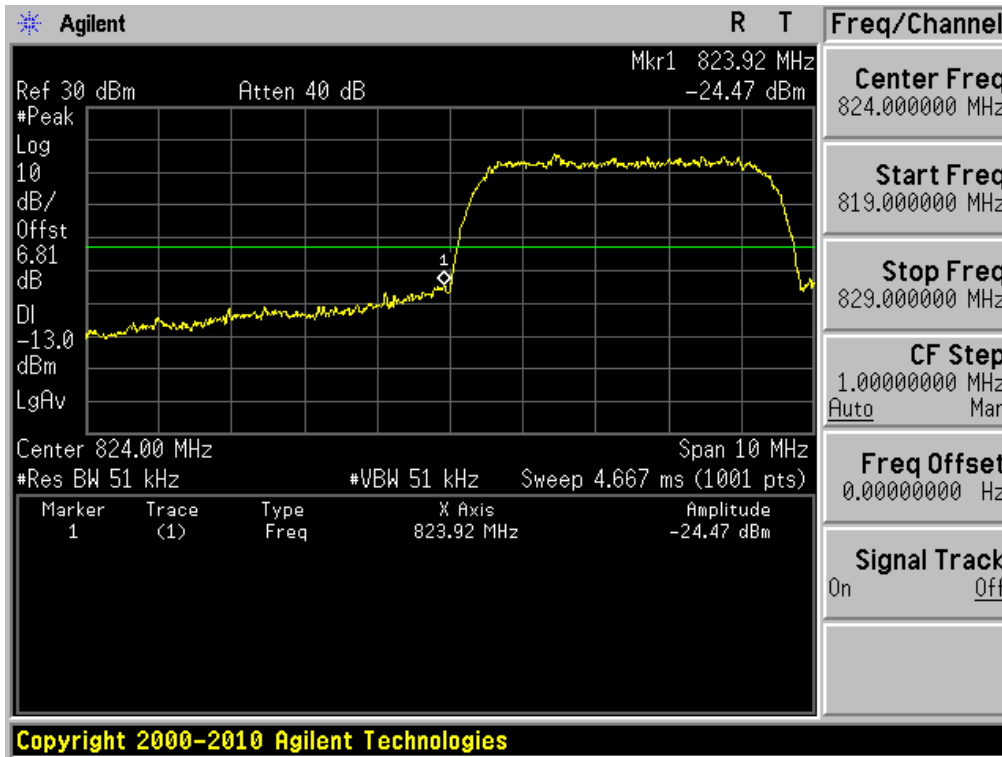

WCDMA850 & Channel: 4132

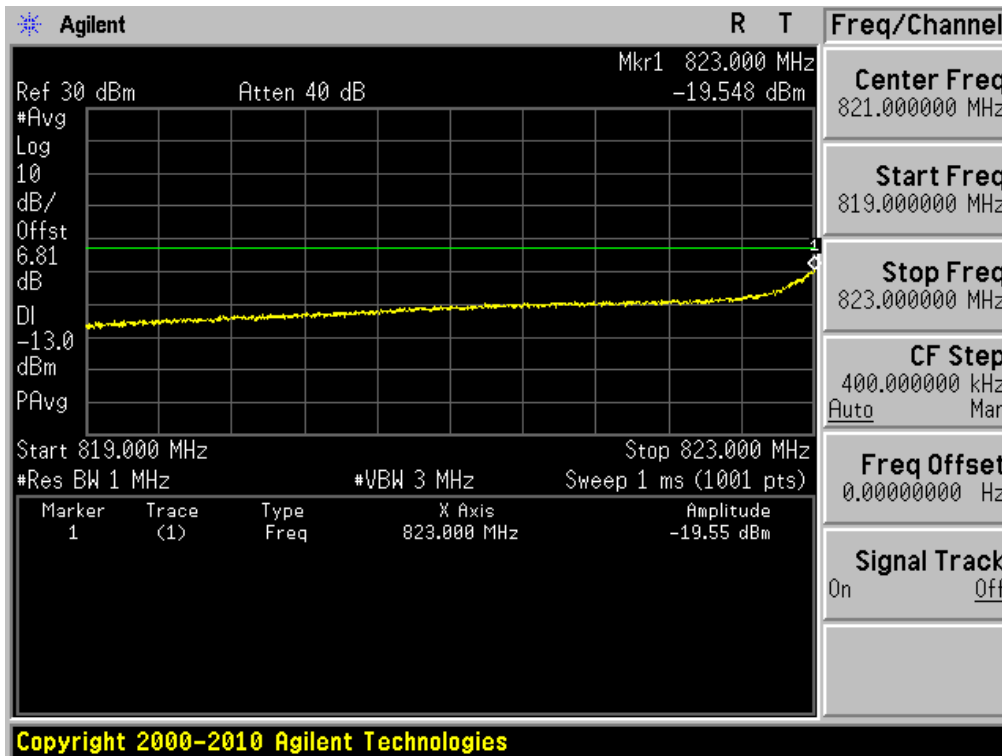

WCDMA850 & Channel: 4233

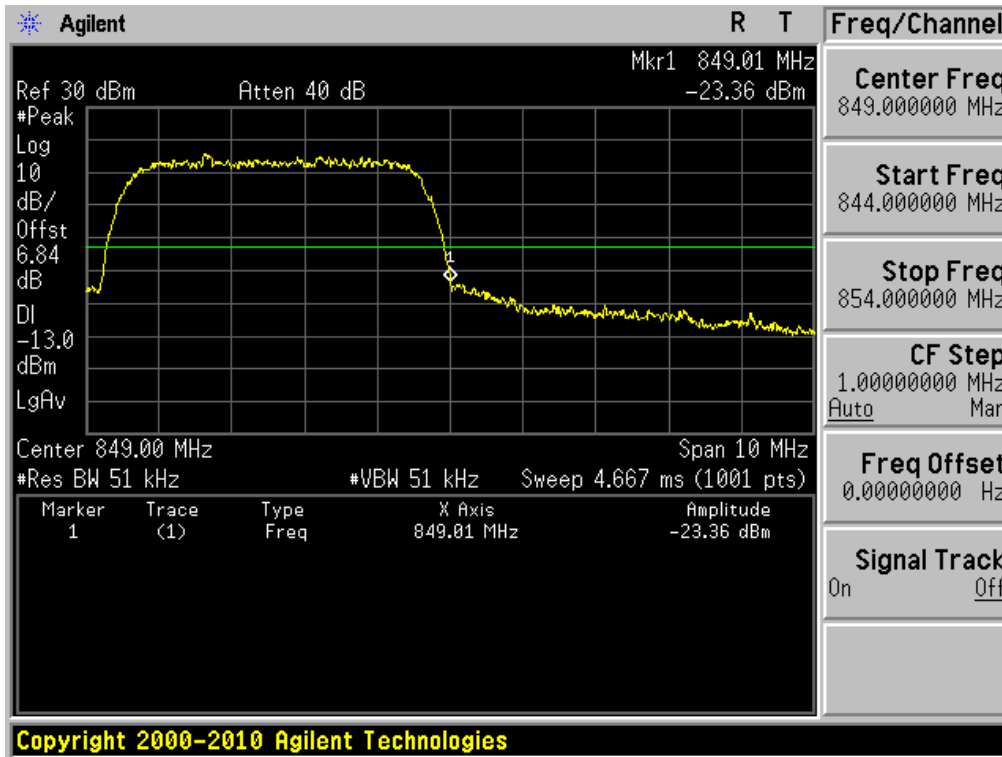

WCDMA850 & Channel: 4233

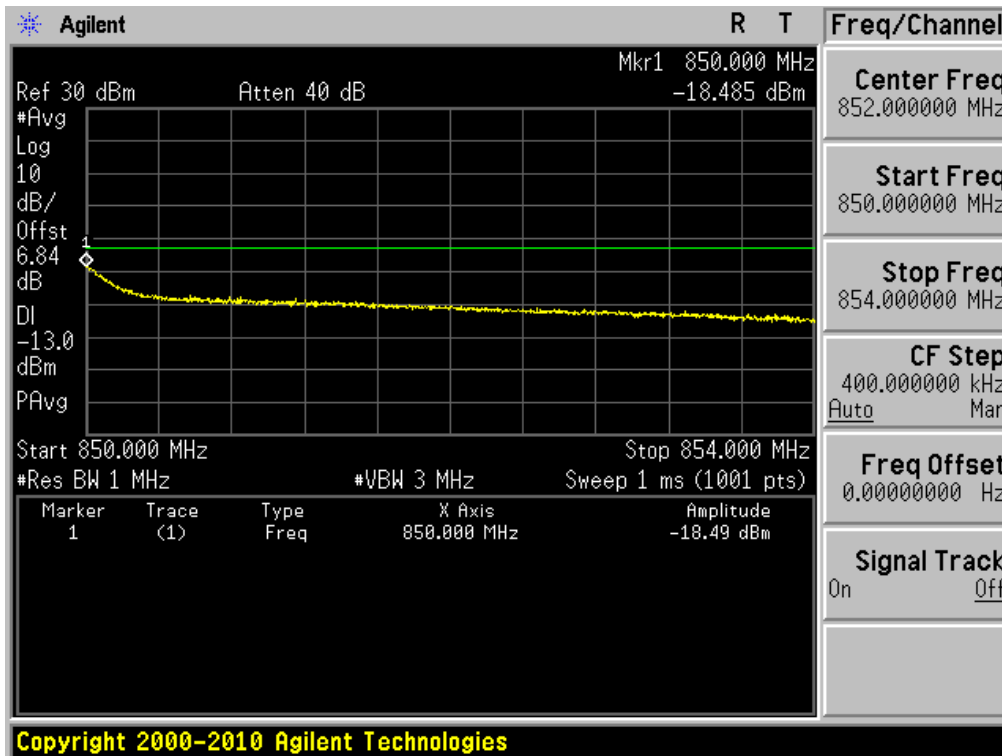

HSUPA850 & Channel: 4132

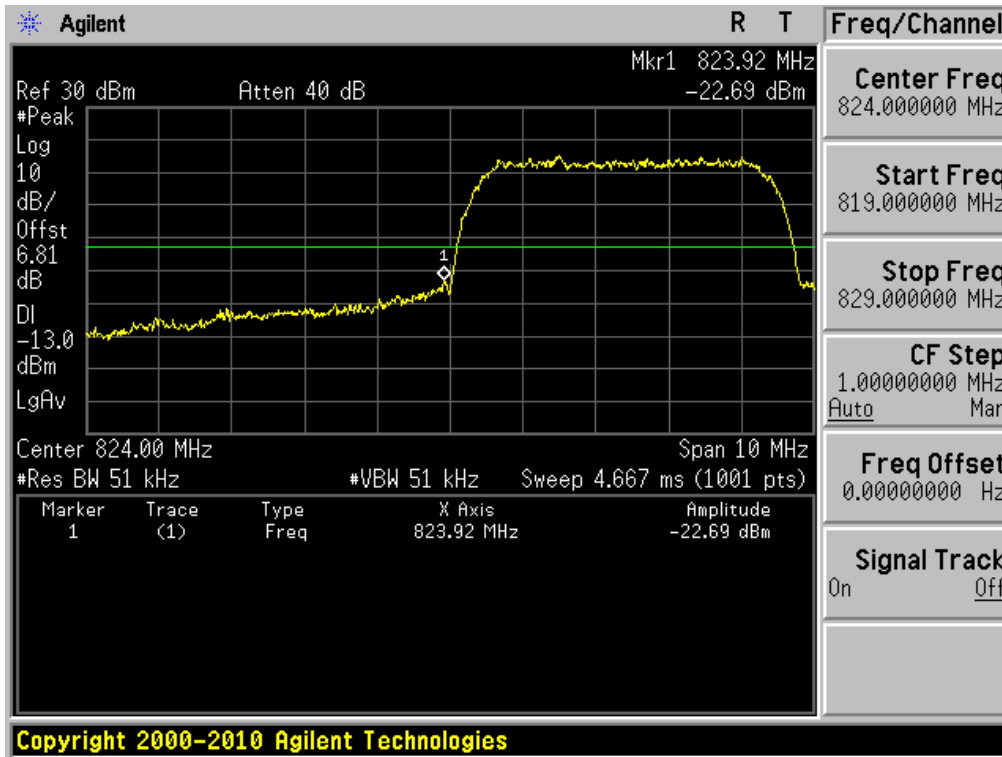

HSUPA850 & Channel: 4132

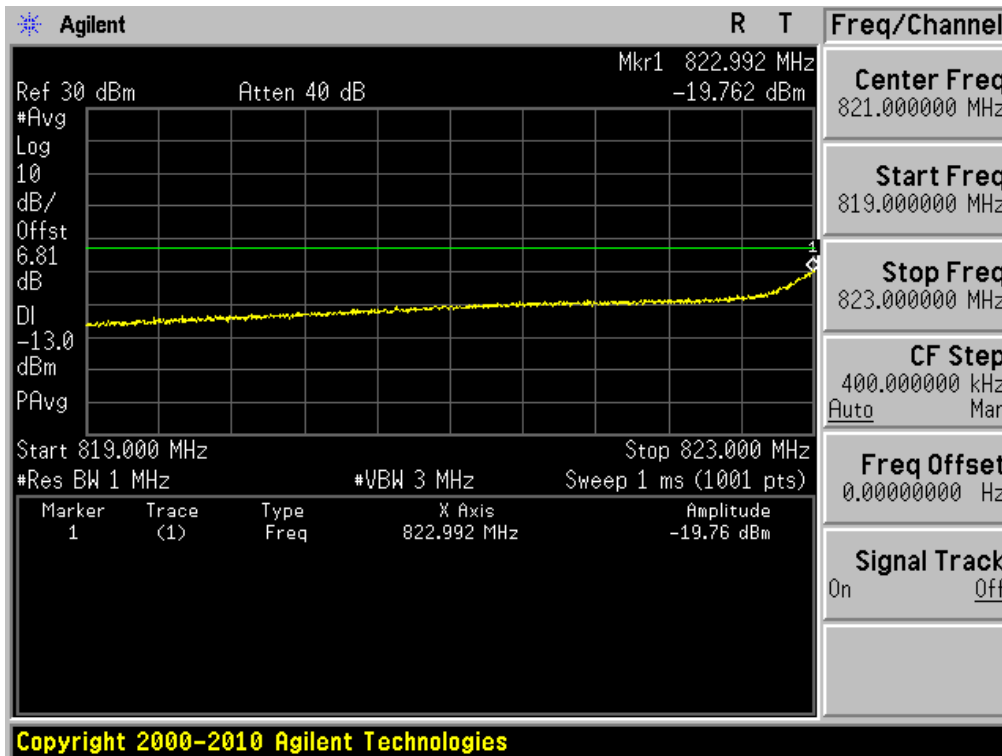

HSUPA850 & Channel: 4233

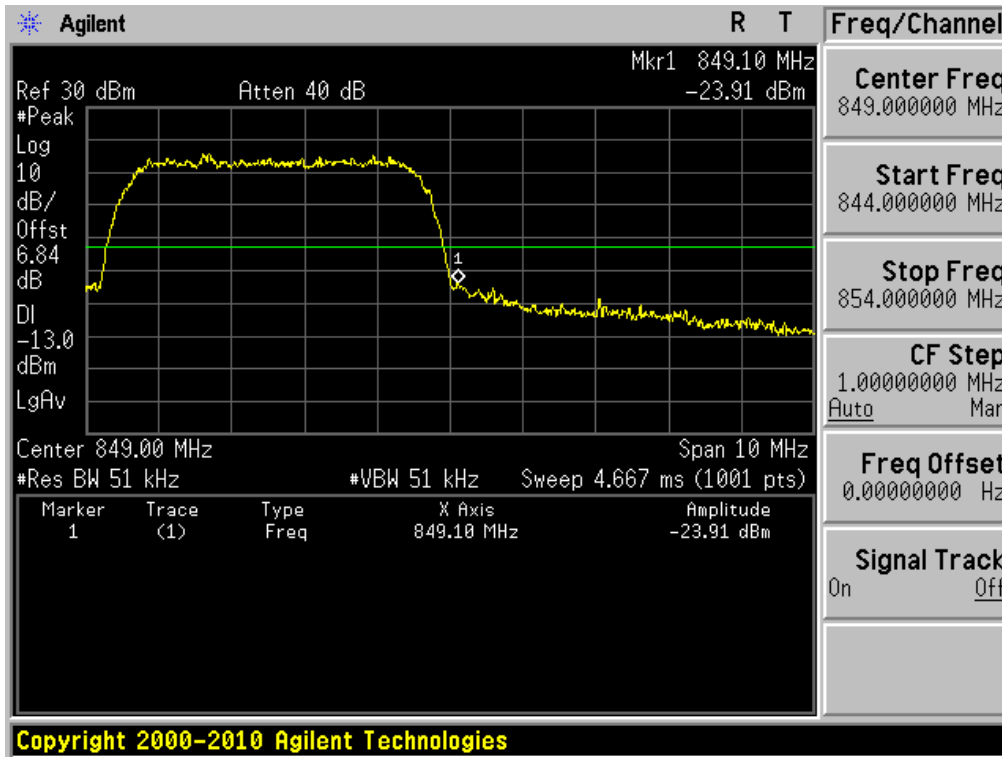

HSUPA850 & Channel: 4233

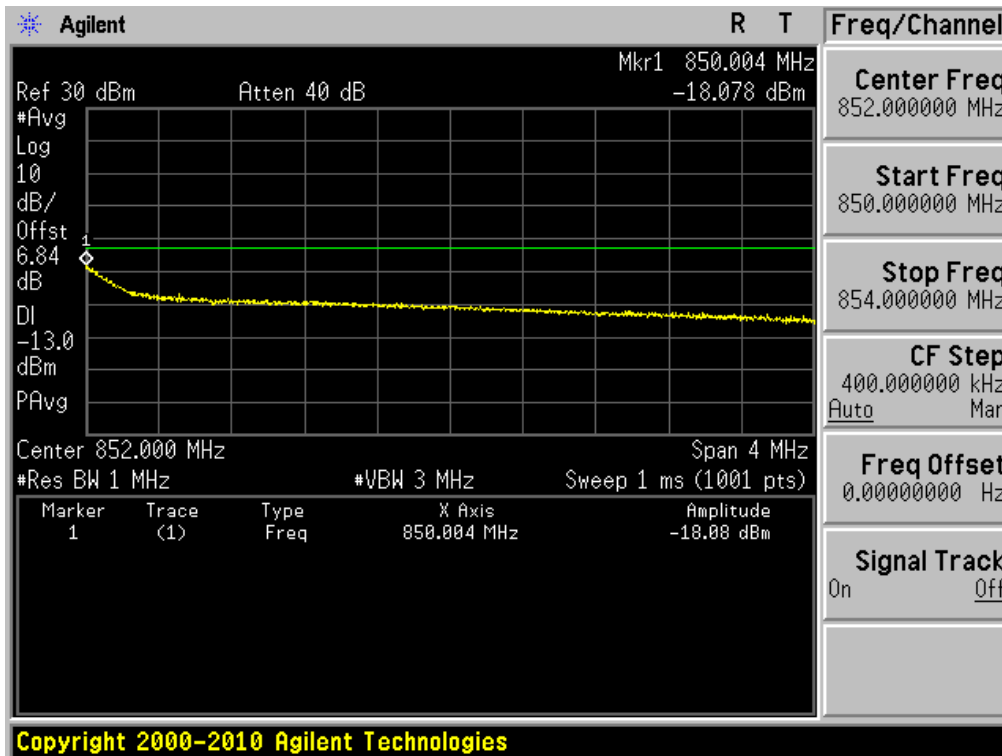

PCS1900 & Channel: 512

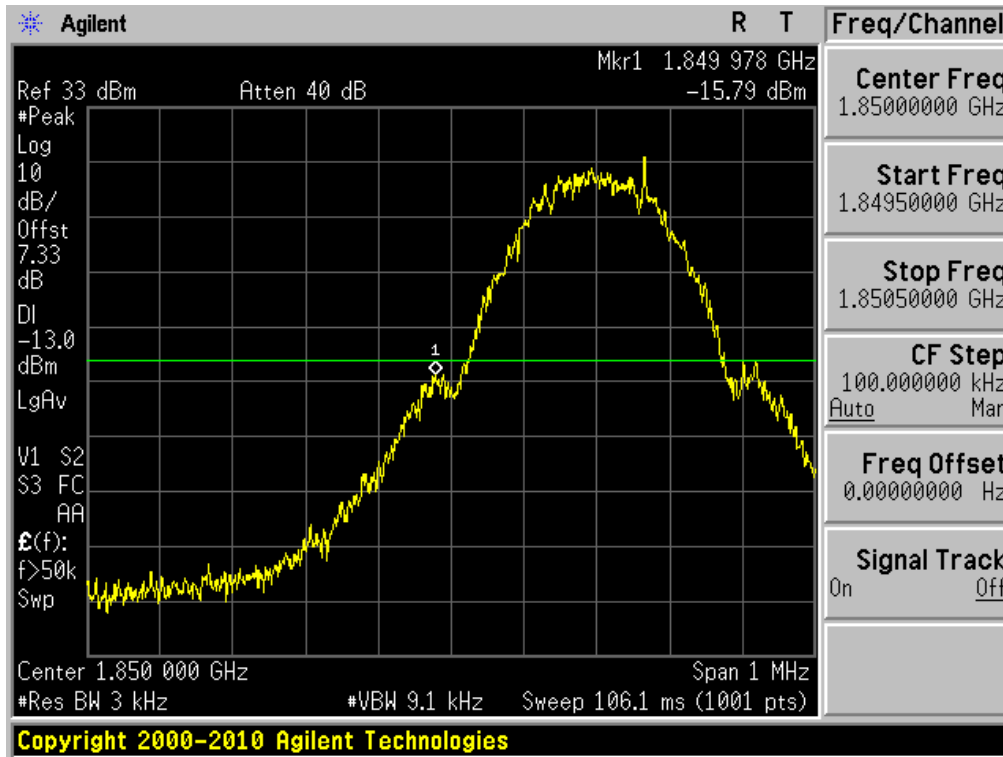

PCS1900 & Channel: 810

