



HCT CO., LTD.

CERTIFICATE OF COMPLIANCE FCC Class II Permissive Change

Applicant Name:
LG Electronics MobileComm U.S.A., Inc.

Date of Issue:
January 05, 2012

Address:
10101 Old Grove Road, San Diego, CA 92131

Location:
HCT CO., LTD., 105-1, Jangam-ri, Majang-Myeon,
Icheon-si, Kyunggi-Do, Korea

Test Report No.: HCTR1201FR06

HCT FRN: 0005866421

FCC ID: ZNFMS840

APPLICANT: LG Electronics MobileComm U.S.A., Inc.

FCC Model(s): MS840
Additional FCC Model(s): LG-MS840, LGMS840
EUT Type: Cellular/PCS/AWS CDMA/ AWS LTE with Bluetooth/ WLAN
FCC Classification: Licensed Portable Transmitter Held to Ear (PCE)
FCC Rule Part(s): §2 , § 24 , §27
Tx Frequency: 1710.7 MHz – 1754.3 MHz (AWS), 1850.7 MHz – 1903.3 MHz (PCS)
Max. RF Output Power:

Band 4, 1.4 MHz :	0.401 W ERP (QPSK) (26.04dBm)
	0.358 W ERP (16-QAM) (25.54dBm)
Band 4, 3 MHz :	0.357 W ERP (QPSK) (25.53dBm)
	0.398 W ERP (16-QAM) (26.00dBm)
Band 4, 5 MHz :	0.356 W ERP (QPSK) (25.52dBm)
	0.438 W ERP (16-QAM) (26.42dBm)
Band 2, 1.4 MHz :	0.628 W EIRP (QPSK) (27.98dBm)
	0.709 W EIRP (16-QAM) (28.51dBm)
Band 2, 3 MHz :	0.639W EIRP (QPSK) (28.06dBm)
	0.696 W EIRP (16-QAM) (28.43dBm)
Band 2, 5 MHz :	0.647 W EIRP (QPSK) (28.11dBm)
	0.701 W EIRP (16-QAM) (28.46dBm)

The measurements shown in this report were made in accordance with the procedures specified in §2.947. I assume full responsibility for the accuracy and completeness of these measurements, and for the qualifications of all persons taking them.

HCT CO., LTD. Certifies that no party to this application has subject to a denial of Federal benefits that includes FCC benefits pursuant to section 5301 of the Anti-Drug Abuse Act of 1998,21 U.S. C.853(a)

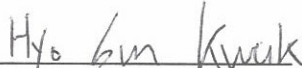
Report prepared by
: Hyo Sun Kwak
Test engineer of RF Team

Approved by
: Sang Jun Lee
Manager of RF Team

This report only responds to the tested sample and may not be reproduced, except in full, without written approval of the HCT Co., Ltd.

FCC Class II Permissive Change REPORT			www.hct.co.kr
Test Report No. HCTR1201FR06	Date of Issue: January 05, 2012	EUT Type: Cellular/PCS/AWS CDMA/ AWS LTE with Bluetooth/ WLAN	FCC ID: ZNFMS840

Version

TEST REPORT NO.	DATE	DESCRIPTION
HCTR1201FR06	January 05, 2012	- First Approval Report

Table of Contents

1. GENERAL INFORMATION	4
2. INTRODUCTION	5
2.1. EUT DESCRIPTION.....	5
2.2. MEASURING INSTRUMENT CALIBRATION.....	5
2.3. TEST FACILITY	5
3. DESCRIPTION OF TESTS	6
3.1 EFFECTIVE RADIATED POWER/EQUIVALENT ISOTROPIC RADIATED POWER.....	6
3.2 OCCUPIED BANDWIDTH.	7
3.3 BLOCK B FREQUENCY RANGE (704 – 710 and 734 – 740 MHz).....	8
3.4 AWS – MOBILE FREQUENCY BLOCKS	8
3.5 CELLULAR – MOBILE FREQUENCY BLOCKS	8
3.6 PEAK-AVERAGE RATIO.	9
3.7 SPURIOUS AND HARMONIC EMISSIONS AT ANTENNA TERMINAL.....	9
3.8 RADIATED SPURIOUS AND HARMONIC EMISSIONS	10
3.9 FREQUENCY STABILITY / VARIATION OF AMBIENT TEMPERATURE	11
4. LIST OF TEST EQUIPMENT	12
5. SUMMARY OF TEST RESULTS	13
6. SAMPLE CALCULATION	14
7. TEST DATA	15
7.1 CONDUCTED OUTPUT POWER	15
7.2 EQUIVALENT ISOTROPIC RADIATED POWER OUTPUT	20
7.3 RADIATED SPURIOUS EMISSIONS.....	28
7.3.1 RADIATED SPURIOUS EMISSIONS (Band 2)	28
7.3.2 RADIATED SPURIOUS EMISSIONS (Band 4)	29

FCC Class II Permissive Change REPORT			www.hct.co.kr
Test Report No. HCTR1201FR06	Date of Issue: January 05, 2012	EUT Type: Cellular/PCS/AWS CDMA/ AWS LTE with Bluetooth/ WLAN	FCC ID: ZNFMS840



MEASUREMENT REPORT

1. GENERAL INFORMATION

Applicant Name: LG Electronics MobileComm U.S.A., Inc.

Address: 10101 Old Grove Road, San Diego, CA 92131

Application Type: FCC Class II Permissive Change

FCC Classification: Licensed Portable Transmitter Held to Ear (PCE)

FCC Rule Part(s): §2 , § 24 , §27

EUT Type: Cellular/PCS/AWS CDMA/ AWS LTE with Bluetooth/ WLAN

FCC Model(s): MS840

Additional FCC Model(s): LG-MS840, LGMS840

Tx Frequency: 1710.7 MHz – 1754.3 MHz (AWS), 1850.7 MHz – 1903.3 MHz(PCS)

Max. RF Output Power:

Band 4, 1.4 MHz :	0.401 W ERP (QPSK) (26.04dBm)
	0.358 W ERP (16-QAM) (25.54dBm)
Band 4, 3 MHz :	0.357 W ERP (QPSK) (25.53dBm)
	0.398 W ERP (16-QAM) (26.00dBm)
Band 4, 5 MHz :	0.356 W ERP (QPSK) (25.52dBm)
	0.438 W ERP (16-QAM) (26.42dBm)
Band 2, 1.4 MHz :	0.628 W EIRP (QPSK) (27.98dBm)
	0.709 W EIRP (16-QAM) (28.51dBm)
Band 2, 3 MHz :	0.639W EIRP (QPSK) (28.06dBm)
	0.696 W EIRP (16-QAM) (28.43dBm)
Band 2, 5 MHz :	0.647 W EIRP (QPSK) (28.11dBm)
	0.701 W EIRP (16-QAM) (28.46dBm)

:

Antenna Specification: Manufacturer: LS Mtron Co. Ltd.
Antenna type: INTERNAL Antenna
Peak Gain: -0.58 dBi

Date(s) of Tests: December 20, 2011 ~ January 03, 2012

FCC Class II Permissive Change REPORT			www.hct.co.kr
Test Report No. HCTR1201FR06	Date of Issue: January 05, 2012	EUT Type: Cellular/PCS/AWS CDMA/ AWS LTE with Bluetooth/ WLAN	FCC ID: ZNFMS840



2. INTRODUCTION

2.1. EUT DESCRIPTION

The MS840 Cellular/PCS/AWS CDMA/ AWS LTE with Bluetooth/ WLAN consists of Cellular CDMA, PCS CDMA, AWS, and EVDO Rev0, A.

2.2. MEASURING INSTRUMENT CALIBRATION

The measuring equipment, which was utilized in performing the tests documented herein, has been calibrated in accordance with the manufacturer's recommendations for utilizing calibration equipment, which is traceable to recognized national standards.

2.3. TEST FACILITY

The SAC(Semi-Anechoic Chamber) and conducted measurement facility used to collect the radiated data are located at the 105-1, Jangam-ri, Majang-Myeon, Icheon-si, Kyunggi-Do, 467-811, Korea. The site is constructed in conformance with the requirements of ANSI C63.4 and CISPR Publication 22. Detailed description of test facility was submitted to the Commission and accepted dated March 02, 2011 (Registration Number: 90661)

FCC Class II Permissive Change REPORT			www.hct.co.kr
Test Report No. HCTR1201FR06	Date of Issue: January 05, 2012	EUT Type: Cellular/PCS/AWS CDMA/ AWS LTE with Bluetooth/ WLAN	FCC ID: ZNFMS840

3. DESCRIPTION OF TESTS

3.1 EFFECTIVE RADIATED POWER/EQUIVALENT ISOTROPIC RADIATED POWER

Test Set-up

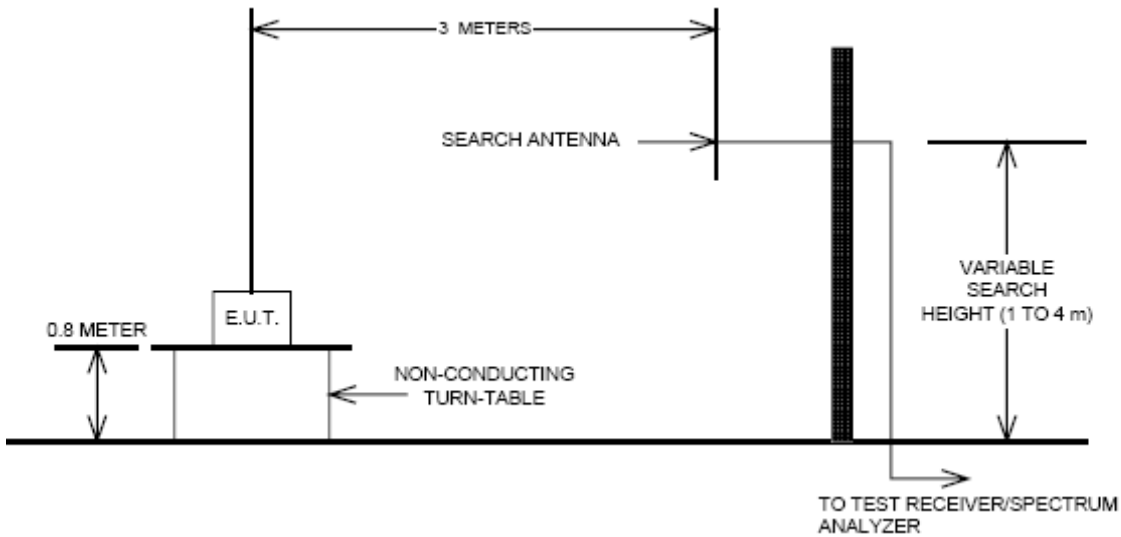

Test Procedure

Radiated emission measurements were performed at an SAC (Semi-Anechoic Chamber)

The equipment under test is placed on a non-conductive styrofoam resin table 3-meters from the receive antenna. A styrofoam turntable was rotated 360° and the receiving antenna scanned from 1-4m in order to capture the maximum emission. A half wave dipole was substituted in place of the EUT. This dipole antenna was driven by a signal generator and the previously recorded signal was duplicated.

The maximum EIRP was calculated by adding the forward power to the calibrated source plus its appropriate gain value. These steps were carried out with the receiving antenna in both vertical and horizontal polarization. For readings above 1GHz, the above procedure is repeated using horn antennas and the difference between the gain of the horn and an isotropic antenna are taken into consideration.

FCC Class II Permissive Change REPORT			www.hct.co.kr
Test Report No. HCTR1201FR06	Date of Issue: January 05, 2012	EUT Type: Cellular/PCS/AWS CDMA/ AWS LTE with Bluetooth/ WLAN	FCC ID: ZNFMS840

3.2 OCCUPIED BANDWIDTH.

Test set-up

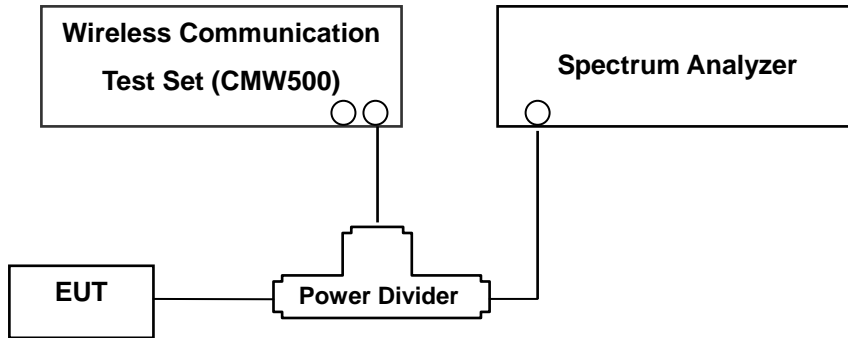

(Configuration of conducted Emission measurement)
Test Procedure

The EUT was setup to maximum output power at its lowest channel. The occupied bandwidth was measured using a spectrum analyzer. The measurements are repeated for the highest and a middle channel. The EUT's occupied bandwidth is measured as the width of the signal between two points, one below the carrier center frequency and one above the carrier frequency, outside of which all emissions are attenuated at least 26 dB below the transmitter power. Plots of the EUT's occupied bandwidth are shown herein.

FCC Class II Permissive Change REPORT			www.hct.co.kr
Test Report No. HCTR1201FR06	Date of Issue: January 05, 2012	EUT Type: Cellular/PCS/AWS CDMA/ AWS LTE with Bluetooth/ WLAN	FCC ID: ZNFMS840

3.3 BLOCK B FREQUENCY RANGE (704 – 710 and 734 – 740 MHz)

§27.5(c)

Three paired channel blocks of 12 MHz each are available for assignment as follows : Block A: 698 – 704 MHz and 728 – 734 MHz ; Block B : 704 – 710 MHz and 734 – 740 MHz ; and Block C : 710 – 716 MHz and 740 – 746 MHz. Two unpaired channel blocks of 6 MHz each are available for assignment as follows : Block D : 716 – 722 MHz ; and Block E : 722- 728 MHz.

3.4 AWS – MOBILE FREQUENCY BLOCKS

§27.5(h)

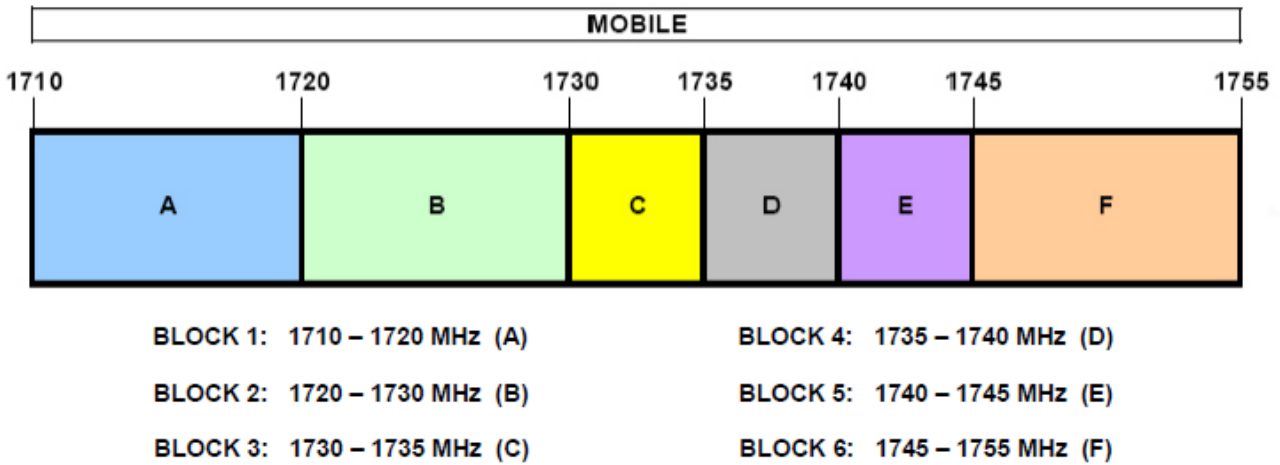

3.5 CELLULAR – MOBILE FREQUENCY BLOCKS

§22.917(a)

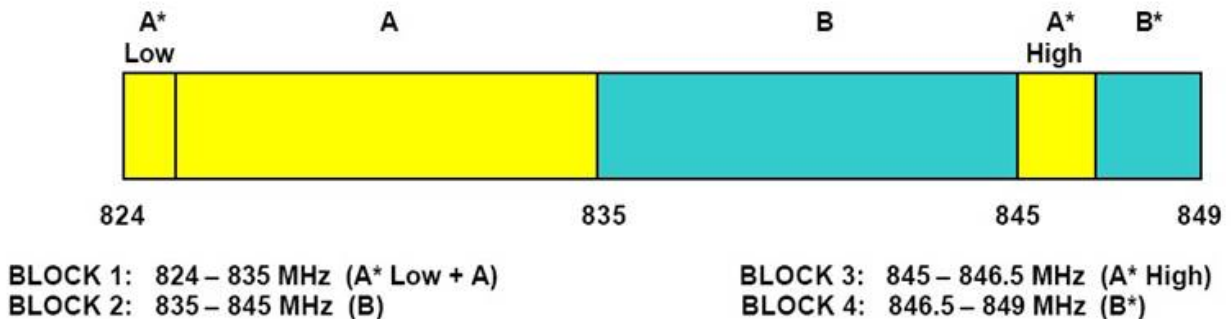



3.6 PEAK-AVERAGE RATIO.

§27.50(d)(5)

A peak to average ratio measurement is performed at the conducted port of the EUT. The spectrum analyzers Complementary Cumulative Distribution Function (CCDF) measurement profile is used to determine the largest deviation between the average and the peak power of the EUT in a given bandwidth. The CCDF curve shows how much time the peak waveform spends at or above a given average power level. The percent of time the signal spends at or above the level defines the probability for that particular power level.

3.7 SPURIOUS AND HARMONIC EMISSIONS AT ANTENNA TERMINAL.

Test Procedure

The level of the carrier and the various conducted spurious and harmonic frequencies is measured by means of a calibrated spectrum analyzer.

The EUT was setup to maximum output power at its lowest channel. The Resolution BW of the analyzer is set to 1 % of the emission bandwidth to show compliance with the – 13 dBm limit, in the 1 MHz bands immediately outside and adjacent to the edge of the frequency block. The 1 MHz RBW was used to scan from 30 MHz to 26.5 GHz. A display line was placed at – 13 dBm to show compliance. The high, lowest and a middle channel were tested for out of band measurements.

- Band Edge Requirement : In the 1MHz bands immediately outside and adjacent to the frequency block, a resolution bandwidth of at least 1 percent of the emission bandwidth of the fundamental emission of the transmitter may be employed to measure the out of band Emissions. Limit, -13dBm.

FCC Class II Permissive Change REPORT			www.hct.co.kr
Test Report No. HCTR1201FR06	Date of Issue: January 05, 2012	EUT Type: Cellular/PCS/AWS CDMA/ AWS LTE with Bluetooth/ WLAN	FCC ID: ZNFMS840

3.8 RADIATED SPURIOUS AND HARMONIC EMISSIONS

Test Set-up

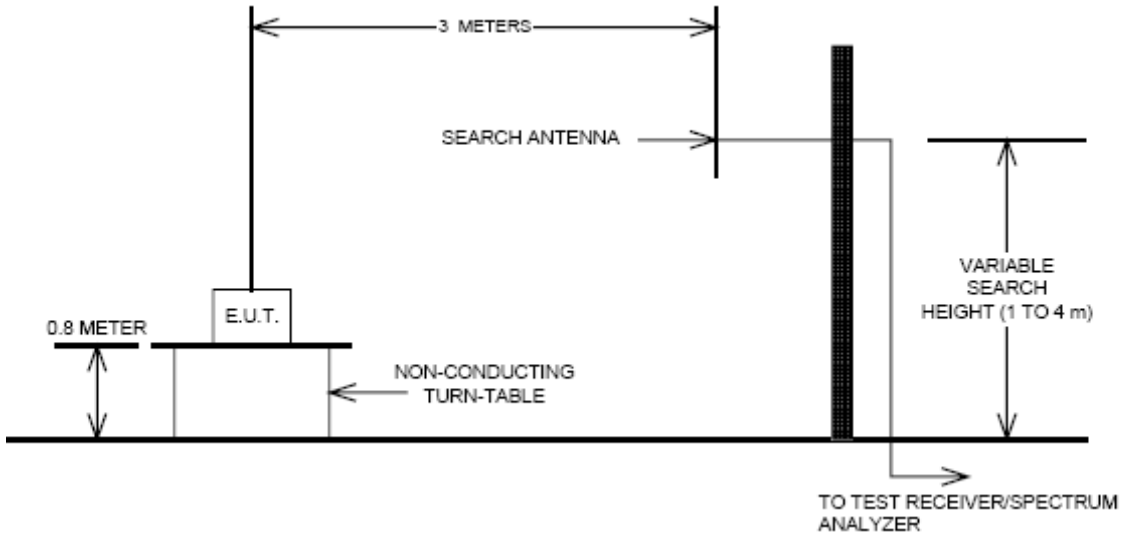

The measurement facilities used for this test have been documented in previous filings with the commission pursuant to section § 2.948. The SAC(Semi-Anechoic Chamber) meets requirements in ANSI C63.4 –2003. A mast capable of lifting the receiving antenna from a height of one to four meters is used together with a rotatable styrofoam platform mounted at three from the antenna mast.

- 1) The unit mounted on a styrofoam turntable 1.5 m × 1.0 m × 0.80 m is 0.8 meter above test site ground level.
- 2) During the emission test, the turntable is rotated and the EUT is manipulated to find the configuration resulting in maximum emission under normal condition of installation and operation.
- 3) The antenna height and polarization are also varied from 1 to 4 meters until the maximum signal is found.
- 4) The spectrum shall be scanned up to the 10th harmonic of the fundamental frequency.

Test Procedure

The equipment under test is placed on a non-conductive styrofoam resin table 3-meters from the receive antenna. A styrofoam turntable was rotated 360° and the receiving antenna scanned from 1-4m in order to capture the maximum emission. A half wave dipole was substituted in place of the EUT. This dipole antenna was driven by a signal generator and the previously recorded signal was duplicated.

The maximum EIRP was calculated by adding the forward power to the calibrated source plus its appropriate gain value. These steps were carried out with the receiving antenna in both vertical and horizontal polarization. For readings above 1GHz, the above procedure is repeated using horn antennas and the difference between the gain of the horn and an isotropic antenna are taken into consideration.

FCC Class II Permissive Change REPORT			www.hct.co.kr
Test Report No. HCTR1201FR06	Date of Issue: January 05, 2012	EUT Type: Cellular/PCS/AWS CDMA/ AWS LTE with Bluetooth/ WLAN	FCC ID: ZNFMS840

3.9 FREQUENCY STABILITY / VARIATION OF AMBIENT TEMPERATURE

Test Set-up

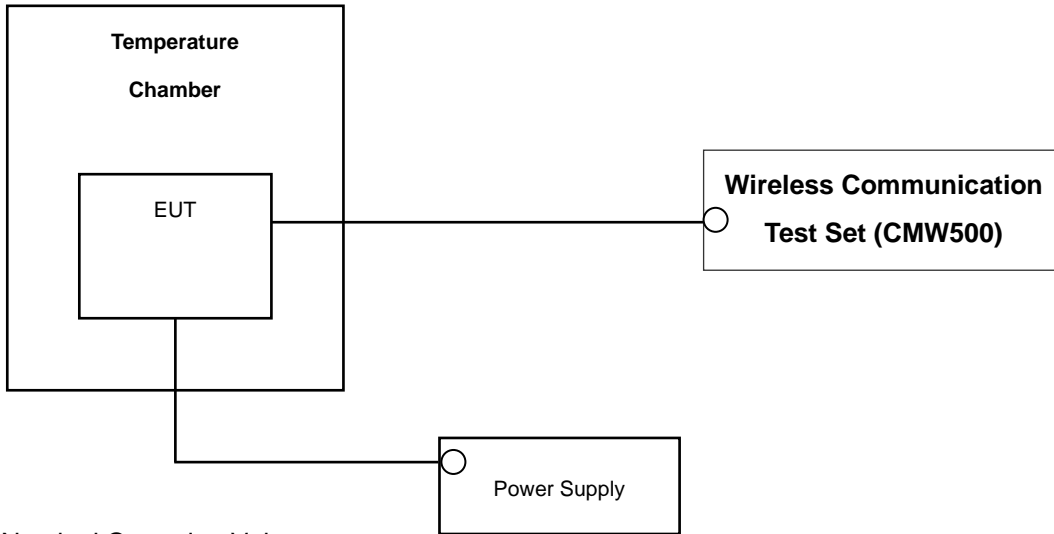

* Nominal Operating Voltage

Test Procedure

The frequency stability of the transmitter is measured by:

- a.) **Temperature:** The temperature is varied from - 30 °C to + 50 °C using an environmental chamber.
- b.) **Primary Supply Voltage:** The primary supply voltage is varied from battery end point to 115 % of the voltage normally at the input to the device or at the power supply terminals if cables are not normally supplied.

Specification — the frequency stability shall be sufficient to ensure that the fundamental emission stays within the authorized frequency block. The frequency stability of the transmitter shall be maintained within $\pm 0.00025\%$ (± 2.5 ppm) of the center frequency.

Time Period and Procedure:

The carrier frequency of the transmitter is measured at room temperature (20°C to provide a reference).

1. The equipment is turned on in a “standby” condition for one minute before applying power to the transmitter. Measurement of the carrier frequency of the transmitter is made within one minute after applying power to the transmitter.
2. Frequency measurements are made at 10°C intervals ranging from -30°C to +50°C. A period of at least one half-hour is provided to allow stabilization of the equipment at each temperature level.

NOTE: The EUT is tested down to the battery endpoint.

FCC Class II Permissive Change REPORT			www.hct.co.kr
Test Report No. HCTR1201FR06	Date of Issue: January 05, 2012	EUT Type: Cellular/PCS/AWS CDMA/ AWS LTE with Bluetooth/ WLAN	FCC ID: ZNFMS840

4. LIST OF TEST EQUIPMENT

Manufacture	Model/ Equipment	Serial Number	Calibration Interval	Calibration Due
R&S	N9020A	MY51110020	Annual	09/23/2012
Agilent	E9327A/ Power Sensor	MY4442009	Annual	05/02/2012
R&S	CMW500/ Base Station	1201.0002K50_10395	Annual	04/20/2012
MITEQ	AMF-6D-001180-35-20P/AMP	1081666	Annual	09/24/2012
Wainwright	WHK1.2/15G-10EF/H.P.F	2	Annual	05/02/2012
Wainwright	WHK3.3/18G-10EF/H.P.F	1	Annual	05/02/2012
Agilent	11636B/ Power Divider	11377	Annual	11/07/2012
Digital	EP-3010/ Power Supply	3110117	Annual	01/04/2012
Schwarzbeck	UHAP/ Dipole Antenna	949	Biennial	03/18/2012
Schwarzbeck	UHAP/ Dipole Antenna	950	Biennial	03/18/2012
Korea Engineering	KR-1005L / Chamber	KRAB05063-3CH	Annual	11/07/2012
Schwarzbeck	BBHA 9120D/ Horn Antenna	147	Biennial	04/13/2012
Agilent	E4440A/Spectrum Analyzer	US45303008	Annual	05/02/2012
WEINSCHL	ATTENUATOR	BR0592	Annual	11/07/2012
REOHDE&SCHWARZ	FSP30/Spectrum Analyzer	839117/011	Annual	03/23/2012
Agilent	8960 (E5515C)/ Base Station	GB44400269	Annual	02/10/2012

5. SUMMARY OF TEST RESULTS

FCC Part Section(s)	Test Description	Test Limit	Test Condition	Test Result
2.1049, 24.238(a) 27.53(h)(1)	Occupied Bandwidth	N/A	CONDUCTED	PASS
2.1051, 24.238(a) 27.53(h)	Band Edge / Spurious and Harmonic Emissions at Antenna Terminal.	$< 43 + 10 \log_{10}(P[\text{Watts}])$ at Band Edge and for all-of-band emissions		PASS
24.232(d),27.50(d)(5)	Peak-Average Ratio	$< 13 \text{ dB}$		PASS
2.1046	Conducted Output Power	N/A		PASS
2.1055, 24.235 27.54	Frequency stability / variation of ambient temperature	$< 2.5 \text{ ppm}$		PASS
24.232(c)	Equivalent Isotropic Radiated Power (PCS)	$< 2 \text{ Watts max. EIRP}$	RADIATED	PASS
27.50(d)(2)	Equivalent Isotropic Radiated Power (AWS)	$< 1 \text{ Watts max. EIRP}$		
2.1053,24.238(a) 27.53(h)	Undesirable Out-of-Band Emissions	$< 43 + 10 \log_{10}(P[\text{Watts}])$ for all out-of-band emissions		PASS

6. SAMPLE CALCULATION

A. ERP Sample Calculation

Mode	Ch./ Freq.		Measured Level(dBm)	Substitute LEVEL(dBm)	Ant. Gain	C.L	Pol.	ERP	
	channel	Freq.(MHz)						W	dBm
LTE	23230	782	-11.56	34.28	-8.32	1.17	H	0.30	24.79

ERP = SubstituteLEVEL(dBm) + Ant. Gain – CL(Cable Loss)

- 1) The EUT mounted on a wooden tripod is 0.8 meter above test site ground level.
- 2) During the test , the turn table is rotated and the antenna height is also varied from 1 to 4 meters until the maximum signal is found.
- 3) Record the field strength meter's level.
- 4) Replace the EUT with dipole/Horn antenna that is connected to a calibrated signal generator.
- 5) Increase the signal generator output till the field strength meter's level is equal to the item (3).
- 6) The signal generator output level with Ant. Gain and cable loss are the rating of effective radiated power (ERP).

B. Emission Designator

QPSK Modulation

Emission Designator = 8M95G7D

LTE BW = 8.95 MHz

G = Phase Modulation

7 = Quantized/Digital Info

D = Amplitude/Angle Modulated

16QAM Modulation

Emission Designator = 8M94W7D

LTE BW = 8.94 MHz

D = Amplitude/Angle Modulated

7 = Quantized/Digital Info

W = Combination (Audio/Data)

FCC Class II Permissive Change REPORT			www.hct.co.kr
Test Report No. HCTR1201FR06	Date of Issue: January 05, 2012	EUT Type: Cellular/PCS/AWS CDMA/ AWS LTE with Bluetooth/ WLAN	FCC ID: ZNFMS840

7. TEST DATA

7.1 CONDUCTED OUTPUT POWER

A base station simulator was used to establish communication with the EUT. The base station simulator parameters were set to produce the maximum power from the EUT. This device was tested under all configurations and the highest power is reported. Conducted Output Powers of EUT are reported below.

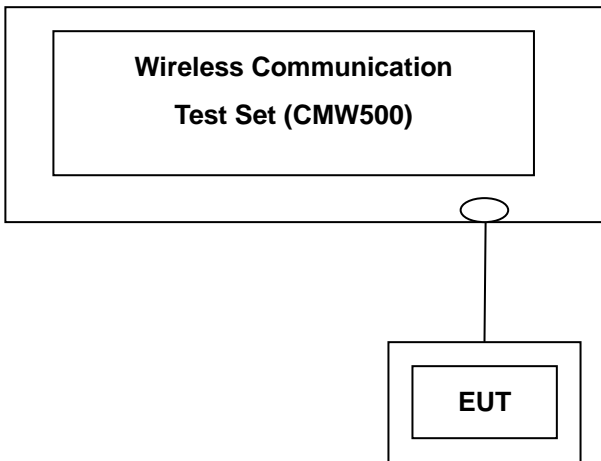

Test Result

Band	Frequency(Mhz)	Channel	Resource Block Size	Resource Block Offset	Average Power [dBm]	
					QPSK	16-QAM
LTE	1710.7	19957	1	0	23.06	23.35
			1	5	22.98	23.32
			3	2	23.06	23.12
			6	0	23.00	23.33

LTE Conducted Average Output Powers (1.4 MHz Band 4 LTE – Low Channel)

Band	Frequency(Mhz)	Channel	Resource Block Size	Resource Block Offset	Average Power [dBm]	
					QPSK	16-QAM
LTE	1732.5	20175	1	0	22.93	23.30
			1	5	22.91	23.25
			3	2	22.88	23.05
			6	0	22.93	23.21

LTE Conducted Average Output Powers (1.4 MHz Band 4 LTE – Mid Channel)

FCC Class II Permissive Change REPORT			www.hct.co.kr
Test Report No. HCTR1201FR06	Date of Issue: January 05, 2012	EUT Type: Cellular/PCS/AWS CDMA/ AWS LTE with Bluetooth/ WLAN	FCC ID: ZNFMS840

Band	Frequency(Mhz)	Channel	Resource Block Size	Resource Block Offset	Average Power [dBm]	
					QPSK	16-QAM
LTE	1754.3	20393	1	0	22.94	23.35
			1	5	23.00	23.29
			3	2	23.02	23.06
			6	0	23.02	23.32

LTE Conducted Average Output Powers (1.4 MHz Band 4 LTE – High Channel)

[3 MHz AWS Band]

Band	Frequency(Mhz)	Channel	Resource Block Size	Resource Block Offset	Average Power [dBm]	
					QPSK	16-QAM
LTE	1711.5	19965	1	0	23.10	22.91
			1	14	23.11	22.99
			8	4	22.94	23.15
			15	0	22.93	22.97

LTE Conducted Average Output Powers (3 MHz Band 4 LTE – Low Channel)

Band	Frequency(Mhz)	Channel	Resource Block Size	Resource Block Offset	Average Power [dBm]	
					QPSK	16-QAM
LTE	1732.5	20175	1	0	22.90	23.22
			1	14	22.91	23.21
			8	4	22.98	23.10
			15	0	23.01	23.13

LTE Conducted Average Output Powers (3 MHz Band 4 LTE – Mid Channel)

Band	Frequency(Mhz)	Channel	Resource Block Size	Resource Block Offset	Average Power [dBm]	
					QPSK	16-QAM
LTE	1753.5	20385	1	0	23.05	22.90
			1	14	23.06	22.81
			8	4	23.00	23.19
			15	0	22.96	22.98

LTE Conducted Average Output Powers (3 MHz Band 4 LTE – High Channel)

[5 MHz AWS Band]

Band	Frequency(Mhz)	Channel	Resource Block Size	Resource Block Offset	Average Power [dBm]	
					QPSK	16-QAM
LTE	1712.5	19975	1	0	23.03	22.96
			1	24	23.07	23.06
			12	6	23.03	22.88
			25	0	23.08	23.18

LTE Conducted Average Output Powers (5 MHz Band 4 LTE – Low Channel)

Band	Frequency(Mhz)	Channel	Resource Block Size	Resource Block Offset	Average Power [dBm]	
					QPSK	16-QAM
LTE	1732.5	20175	1	0	22.89	23.27
			1	24	22.86	23.22
			12	6	22.97	22.83
			25	0	22.91	23.13

LTE Conducted Average Output Powers (5 MHz Band 4 LTE – Mid Channel)

Band	Frequency(Mhz)	Channel	Resource Block Size	Resource Block Offset	Average Power [dBm]	
					QPSK	16-QAM
LTE	1752.5	20375	1	0	23.02	22.72
			1	24	23.00	22.75
			12	6	22.89	22.80
			25	0	23.02	23.08

LTE Conducted Average Output Powers (5 MHz Band 4 LTE – High Channel)

[1.4 MHz PCS Band]

Band	Frequency(Mhz)	Channel	Resource Block Size	Resource Block Offset	Average Power [dBm]	
					QPSK	16-QAM
LTE	1850.7	18607	1	0	23.01	23.42
			1	5	23.02	23.29
			3	2	23.00	22.96
			6	0	22.99	23.05

LTE Conducted Average Output Powers (1.4 MHz Band 2 LTE – Low Channel)

Band	Frequency(Mhz)	Channel	Resource Block Size	Resource Block Offset	Average Power [dBm]	
					QPSK	16-QAM
LTE	1880	18900	1	0	23.14	23.46
			1	5	23.13	23.44
			3	2	23.25	23.27
			6	0	23.16	23.47

LTE Conducted Average Output Powers (1.4 MHz Band 2 LTE – Mid Channel)

Band	Frequency(Mhz)	Channel	Resource Block Size	Resource Block Offset	Average Power [dBm]	
					QPSK	16-QAM
LTE	1880	18900	1	0	23.03	23.35
			1	5	22.88	23.21
			3	2	23.04	23.06
			6	0	23.02	23.26

LTE Conducted Average Output Powers (1.4 MHz Band 2 LTE – High Channel)

[3 MHz PCS Band]

Band	Frequency(Mhz)	Channel	Resource Block Size	Resource Block Offset	Average Power [dBm]	
					QPSK	16-QAM
LTE	1851.5	18615	1	0	23.08	22.98
			1	14	23.10	22.85
			8	4	23.00	23.14
			15	0	23.02	23.00

LTE Conducted Average Output Powers (3 MHz Band 2 LTE – Low Channel)

Band	Frequency(Mhz)	Channel	Resource Block Size	Resource Block Offset	Average Power [dBm]	
					QPSK	16-QAM
LTE	1880	18900	1	0	23.19	23.07
			1	14	23.25	22.96
			8	4	23.17	23.30
			15	0	23.10	23.13

LTE Conducted Average Output Powers (3 MHz Band 2 LTE – Mid Channel)

Band	Frequency(Mhz)	Channel	Resource Block Size	Resource Block Offset	Average Power [dBm]	
					QPSK	16-QAM
LTE	1908.5	19185	1	0	23.24	23.10
			1	14	23.01	22.89
			8	4	23.03	23.21
			15	0	23.07	23.05

LTE Conducted Average Output Powers (3 MHz Band 2 LTE – Mid Channel)

[5 MHz PCS Band]

Band	Frequency(Mhz)	Channel	Resource Block Size	Resource Block Offset	Average Power [dBm]	
					QPSK	16-QAM
LTE	1852.5	18625	1	0	23.01	22.90
			1	24	23.14	22.78
			12	6	23.00	22.87
			25	0	23.04	23.14

LTE Conducted Average Output Powers (5 MHz Band 2 LTE – Low Channel)

Band	Frequency(Mhz)	Channel	Resource Block Size	Resource Block Offset	Average Power [dBm]	
					QPSK	16-QAM
LTE	1880	18900	1	0	23.20	22.93
			1	24	23.23	22.90
			12	6	23.21	23.03
			25	0	23.24	23.33

LTE Conducted Average Output Powers (5 MHz Band 2 LTE – Mid Channel)

Band	Frequency(Mhz)	Channel	Resource Block Size	Resource Block Offset	Average Power [dBm]	
					QPSK	16-QAM
LTE	1907.5	19175	1	0	23.34	23.24
			1	24	23.00	22.98
			12	6	23.26	23.02
			25	0	23.29	23.30

LTE Conducted Average Output Powers (5 MHz Band 2 LTE – High Channel)

Note : Detecting mode is average.

FCC Class II Permissive Change REPORT			www.hct.co.kr
Test Report No. HCTR1201FR06	Date of Issue: January 05, 2012	EUT Type: Cellular/PCS/AWS CDMA/ AWS LTE with Bluetooth/ WLAN	FCC ID: ZNFMS840

7.2 EQUIVALENT ISOTROPIC RADIATED POWER OUTPUT

Mode	RB/RB SIZE	Freq (MHz)	Measured Level (dBm)	Substitute Level (dBm)	Ant. Gain(dBi)	C.L	Pol	ERP	
								W	dBm
1.4 MHz BAND QPSK	1/0	1710.7	-18.54	14.89	9.98	2.69	H	0.17	22.18
		1732.5	-15.83	17.58	10.06	2.70	H	0.31	24.94
		1754.3	-16.53	16.85	10.14	2.68	H	0.27	24.30
	1/5	1710.7	-17.79	15.64	9.98	2.69	H	0.20	22.93
		1732.5	-15.77	17.64	10.06	2.70	H	0.32	25.00
		1754.3	-16.49	16.89	10.14	2.68	H	0.27	24.34
	3/2	1710.7	-18.21	15.22	9.98	2.69	H	0.18	22.51
		1732.5	-15.91	17.50	10.06	2.70	H	0.31	24.86
		1754.3	-16.61	16.77	10.14	2.68	H	0.26	24.22
	6/0	1710.7	-17.61	15.82	9.98	2.69	H	0.20	23.11
		1732.5	-14.73	18.68	10.06	2.70	H	0.40	26.04
		1754.3	-16.38	17.00	10.14	2.68	H	0.28	24.45

Equivalent Isotropic Radiated Power Output Data (Band 4)

Mode	RB/RB SIZE	Freq (MHz)	Measured Level (dBm)	Substitute Level (dBm)	Ant. Gain(dBi)	C.L	Pol	ERP	
								W	dBm
1.4 MHz BAND 16QAM	1/0	1710.7	-17.58	15.85	9.98	2.69	H	0.21	23.14
		1732.5	-15.52	17.89	10.06	2.70	H	0.33	25.25
		1754.3	-15.62	17.76	10.14	2.68	H	0.33	25.21
	1/5	1710.7	-17.12	16.31	9.98	2.69	H	0.23	23.60
		1732.5	-15.30	18.11	10.06	2.70	H	0.35	25.47
		1754.3	-15.63	17.75	10.14	2.68	H	0.33	25.20
	3/2	1710.7	-17.23	16.20	9.98	2.69	H	0.22	23.49
		1732.5	-15.23	18.18	10.06	2.70	H	0.36	25.54
		1754.3	-15.96	17.42	10.14	2.68	H	0.31	24.87
	6/0	1710.7	-17.20	16.23	9.98	2.69	H	0.22	23.52
		1732.5	-15.42	17.99	10.06	2.70	H	0.34	25.35
		1754.3	-15.73	17.65	10.14	2.68	H	0.32	25.10

Equivalent Isotropic Radiated Power Output Data (Band 4)

Mode	RB/RB SIZE	Freq (MHz)	Measured Level (dBm)	Substitute Level (dBm)	Ant. Gain(dBi)	C.L	Pol	ERP	
								W	dBm
3 MHz BAND QPSK	1/0	1711.5	-17.82	15.61	9.98	2.69	H	0.19	22.90
		1732.5	-15.38	18.03	10.06	2.70	H	0.35	25.39
		1753.5	-16.53	16.85	10.14	2.68	H	0.27	24.30
	1/14	1711.5	-17.51	15.92	9.98	2.69	H	0.21	23.21
		1732.5	-15.46	17.95	10.06	2.70	H	0.34	25.31
		1753.5	-16.67	16.71	10.14	2.68	H	0.26	24.16
	8/4	1711.5	-17.62	15.81	9.98	2.69	H	0.20	23.10
		1732.5	-15.24	18.17	10.06	2.70	H	0.36	25.53
		1753.5	-16.41	16.97	10.14	2.68	H	0.28	24.42
	15/0	1711.5	-18.30	15.13	9.98	2.69	H	0.17	22.42
		1732.5	-16.08	17.33	10.06	2.70	H	0.29	24.69
		1753.5	-17.23	16.15	10.14	2.68	H	0.23	23.60

Equivalent Isotropic Radiated Power Output Data (Band 4)

Mode	RB/RB SIZE	Freq (MHz)	Measured Level (dBm)	Substitute Level (dBm)	Ant. Gain(dBi)	C.L	Pol	ERP	
								W	dBm
3 MHz BAND 16QAM	1/0	1711.5	-17.07	16.36	9.98	2.69	H	0.23	23.65
		1732.5	-15.21	18.20	10.06	2.70	H	0.36	25.56
		1753.5	-15.74	17.64	10.14	2.68	H	0.32	25.09
	1/14	1711.5	-17.01	16.42	9.98	2.69	H	0.23	23.71
		1732.5	-15.18	18.23	10.06	2.70	H	0.36	25.59
		1753.5	-15.80	17.58	10.14	2.68	H	0.32	25.03
	8/4	1711.5	-16.80	16.63	9.98	2.69	H	0.25	23.92
		1732.5	-14.77	18.64	10.06	2.70	H	0.40	26.00
		1753.5	-15.99	17.39	10.14	2.68	H	0.30	24.84
	15/0	1711.5	-17.43	16.00	9.98	2.69	H	0.21	23.29
		1732.5	-15.39	18.02	10.06	2.70	H	0.35	25.38
		1753.5	-16.72	16.66	10.14	2.68	H	0.26	24.11

Equivalent Isotropic Radiated Power Output Data (Band 4)

Mode	RB/RB SIZE	Freq (MHz)	Measured Level (dBm)	Substitute Level (dBm)	Ant. Gain(dBi)	C.L	Pol	ERP	
								W	dBm
5 MHz BAND QPSK	1/0	1712.5	-17.99	15.44	9.98	2.69	H	0.19	22.73
		1732.5	-15.56	17.85	10.06	2.70	H	0.33	25.21
		1752.5	-16.57	16.81	10.14	2.68	H	0.27	24.26
	1/24	1712.5	-17.57	15.86	9.98	2.69	H	0.21	23.15
		1732.5	-15.50	17.91	10.06	2.70	H	0.34	25.27
		1752.5	-16.79	16.59	10.14	2.68	H	0.25	24.04
	12/6	1712.5	-18.08	15.35	9.98	2.69	H	0.18	22.64
		1732.5	-15.62	17.79	10.06	2.70	H	0.33	25.15
		1752.5	-16.86	16.52	10.14	2.68	H	0.25	23.97
	25/0	1712.5	-17.54	15.89	9.98	2.69	H	0.21	23.18
		1732.5	-15.25	18.16	10.06	2.70	H	0.36	25.52
		1752.5	-16.05	17.33	10.14	2.68	H	0.30	24.78

Equivalent Isotropic Radiated Power Output Data (Band 4)

Mode	RB/RB SIZE	Freq (MHz)	Measured Level (dBm)	Substitute Level (dBm)	Ant. Gain(dBi)	C.L	Pol	ERP	
								W	dBm
5 MHz BAND 16QAM	1/0	1712.5	-17.77	15.66	9.98	2.69	H	0.20	22.95
		1732.5	-15.49	17.92	10.06	2.70	H	0.34	25.28
		1752.5	-15.86	17.52	10.14	2.68	H	0.31	24.97
	1/24	1712.5	-17.62	15.81	9.98	2.69	H	0.20	23.10
		1732.5	-15.26	18.15	10.06	2.70	H	0.36	25.51
		1752.5	-16.26	17.12	10.14	2.68	H	0.29	24.57
	12/6	1712.5	-17.45	15.98	9.98	2.69	H	0.21	23.27
		1732.5	-15.05	18.36	10.06	2.70	H	0.37	25.72
		1752.5	-16.15	17.23	10.14	2.68	H	0.29	24.68
	25/0	1712.5	-16.61	16.82	9.98	2.69	H	0.26	24.11
		1732.5	-14.35	19.06	10.06	2.70	H	0.44	26.42
		1752.5	-15.49	17.89	10.14	2.68	H	0.34	25.34

Equivalent Isotropic Radiated Power Output Data (Band 4)



NOTES:

Effective Radiated Power Output Measurements by Substitution Method
according to ANSI/TIA/EIA-603-C-2004, Aug. 17, 2004:

The EUT was placed on a non-conductive styrofoam resin table 3-meters from the receive antenna. The receive antenna height and turntable rotation was adjusted for the highest reading on the receive spectrum analyzer. For 1 MHz BW signals, a peak detector is used, with RBW = VBW = 1 MHz. For 10 MHz BW signals, a peak detector is used, with RBW = VBW = 10 MHz. A half-wave dipole was substituted in place of the EUT. This dipole antenna was driven by a signal generator and the level of the signal generator was adjusted to obtain the same receive spectrum analyzer reading. The conducted power at the terminals of the Horn antenna is measured. The difference between the gain of the horn and an isotropic antenna is taken into consideration and the EIRP is recorded.

Also, we have done x, y, z planes in EUT and horizontal and vertical polarization in detecting antenna. The worst case of the EUT is x plane in LTE mode. Also worst case of detecting Antenna is horizontal polarization in LTE mode.

FCC Class II Permissive Change REPORT			www.hct.co.kr
Test Report No. HCTR1201FR06	Date of Issue: January 05, 2012	EUT Type: Cellular/PCS/AWS CDMA/ AWS LTE with Bluetooth/ WLAN	FCC ID: ZNFMS840

Mode	RB/RB SIZE	Freq (MHz)	Measured Level (dBm)	Substitute Level (dBm)	Ant. Gain(dBi)	C.L	Pol	ERP	
								W	dBm
1.4 MHz BAND QPSK	1/0	1850.7	-14.82	18.89	10.40	2.83	H	0.44	26.45
		1880.0	-14.76	19.12	10.43	2.81	H	0.47	26.74
		1909.3	-13.62	20.37	10.47	2.86	H	0.63	27.98
	1/5	1850.7	-14.83	18.88	10.40	2.83	H	0.44	26.44
		1880.0	-14.72	19.16	10.43	2.81	H	0.48	26.78
		1909.3	-13.75	20.24	10.47	2.86	H	0.61	27.85
	3/2	1850.7	-15.13	18.58	10.40	2.83	H	0.41	26.14
		1880.0	-14.72	19.16	10.43	2.81	H	0.48	26.78
		1909.3	-13.91	20.08	10.47	2.86	H	0.59	27.69
	6/0	1850.7	-14.87	18.84	10.40	2.83	H	0.44	26.40
		1880.0	-14.29	19.59	10.43	2.81	H	0.53	27.21
		1909.3	-13.84	20.15	10.47	2.86	H	0.60	27.76

Equivalent Isotropic Radiated Power Output Data (Band 2)

Mode	RB/RB SIZE	Freq (MHz)	Measured Level (dBm)	Substitute Level (dBm)	Ant. Gain(dBi)	C.L	Pol	ERP	
								W	dBm
1.4 MHz BAND 16QAM	1/0	1850.7	-14.41	19.30	10.40	2.83	H	0.49	26.86
		1880.0	-13.85	20.03	10.43	2.81	H	0.58	27.65
		1909.3	-13.09	20.90	10.47	2.86	H	0.71	28.51
	1/5	1850.7	-14.76	18.95	10.40	2.83	H	0.45	26.51
		1880.0	-13.77	20.11	10.43	2.81	H	0.59	27.73
		1909.3	-13.11	20.88	10.47	2.86	H	0.71	28.49
	3/2	1850.7	-14.54	19.17	10.40	2.83	H	0.47	26.73
		1880.0	-13.84	20.04	10.43	2.81	H	0.58	27.66
		1909.3	-13.46	20.53	10.47	2.86	H	0.65	28.14
	6/0	1850.7	-14.40	19.31	10.40	2.83	H	0.49	26.87
		1880.0	-13.73	20.15	10.43	2.81	H	0.60	27.77
		1909.3	-13.14	20.85	10.47	2.86	H	0.70	28.46

Equivalent Isotropic Radiated Power Output Data (Band 2)

Mode	RB/RB SIZE	Freq (MHz)	Measured Level (dBm)	Substitute Level (dBm)	Ant. Gain(dBi)	C.L	Pol	ERP	
								W	dBm
3 MHz BAND QPSK	1/0	1851.5	-15.29	18.42	10.40	2.83	H	0.40	25.98
		1880.0	-14.15	19.73	10.43	2.81	H	0.54	27.35
		1908.5	-13.59	20.40	10.47	2.86	H	0.63	28.01
	1/14	1851.5	-15.67	18.04	10.40	2.83	H	0.36	25.60
		1880.0	-14.46	19.42	10.43	2.81	H	0.51	27.04
		1908.5	-13.60	20.39	10.47	2.86	H	0.63	28.00
	8/4	1851.5	-15.46	18.25	10.40	2.83	H	0.38	25.81
		1880.0	-14.45	19.43	10.43	2.81	H	0.51	27.05
		1908.5	-13.54	20.45	10.47	2.86	H	0.64	28.06
	15/0	1851.5	-15.83	17.88	10.40	2.83	H	0.35	25.44
		1880.0	-14.97	18.91	10.43	2.81	H	0.45	26.53
		1908.5	-14.33	19.66	10.47	2.86	H	0.53	27.27

Equivalent Isotropic Radiated Power Output Data (Band 2)

Mode	RB/RB SIZE	Freq (MHz)	Measured Level (dBm)	Substitute Level (dBm)	Ant. Gain(dBi)	C.L	Pol	ERP	
								W	dBm
3 MHz BAND 16QAM	1/0	1851.5	-15.09	18.62	10.40	2.83	H	0.41	26.18
		1880.0	-14.35	19.53	10.43	2.81	H	0.52	27.15
		1908.5	-13.35	20.64	10.47	2.86	H	0.67	28.25
	1/14	1851.5	-15.33	18.38	10.40	2.83	H	0.39	25.94
		1880.0	-13.79	20.09	10.43	2.81	H	0.59	27.71
		1908.5	-13.83	20.16	10.47	2.86	H	0.60	27.77
	8/4	1851.5	-15.14	18.57	10.40	2.83	H	0.41	26.13
		1880.0	-13.74	20.14	10.43	2.81	H	0.60	27.76
		1908.5	-13.17	20.82	10.47	2.86	H	0.70	28.43
	15/0	1851.5	-15.39	18.32	10.40	2.83	H	0.39	25.88
		1880.0	-14.16	19.72	10.43	2.81	H	0.54	27.34
		1908.5	-13.61	20.38	10.47	2.86	H	0.63	27.99

Equivalent Isotropic Radiated Power Output Data (Band 2)

Mode	RB/RB SIZE	Freq (MHz)	Measured Level (dBm)	Substitute Level (dBm)	Ant. Gain(dBi)	C.L	Pol	ERP	
								W	dBm
5 MHz BAND QPSK	1/0	1852.5	-14.90	18.81	10.40	2.83	H	0.43	26.37
		1880.0	-14.21	19.67	10.43	2.81	H	0.54	27.29
		1907.5	-13.49	20.50	10.47	2.86	H	0.65	28.11
	1/24	1852.5	-15.19	18.52	10.40	2.83	H	0.41	26.08
		1880.0	-14.52	19.36	10.43	2.81	H	0.50	26.98
		1907.5	-13.60	20.39	10.47	2.86	H	0.63	28.00
	12/6	1852.5	-15.50	18.21	10.40	2.83	H	0.38	25.77
		1880.0	-14.70	19.18	10.43	2.81	H	0.48	26.80
		1907.5	-13.88	20.11	10.47	2.86	H	0.59	27.72
	25/0	1852.5	-14.88	18.83	10.40	2.83	H	0.44	26.39
		1880.0	-14.03	19.85	10.43	2.81	H	0.56	27.47
		1907.5	-14.50	19.49	10.47	2.86	H	0.51	27.10

Equivalent Isotropic Radiated Power Output Data (Band 2)

Mode	RB/RB SIZE	Freq (MHz)	Measured Level (dBm)	Substitute Level (dBm)	Ant. Gain(dBi)	C.L	Pol	ERP	
								W	dBm
5 MHz BAND 16QAM	1/0	1852.5	-14.97	18.74	10.40	2.83	H	0.43	26.30
		1880.0	-14.31	19.57	10.43	2.81	H	0.52	27.19
		1907.5	-13.65	20.34	10.47	2.86	H	0.62	27.95
	1/24	1852.5	-15.33	18.38	10.40	2.83	H	0.39	25.94
		1880.0	-14.45	19.43	10.43	2.81	H	0.51	27.05
		1907.5	-13.79	20.20	10.47	2.86	H	0.60	27.81
	12/6	1852.5	-15.16	18.55	10.40	2.83	H	0.41	26.11
		1880.0	-13.92	19.96	10.43	2.81	H	0.57	27.58
		1907.5	-13.22	20.77	10.47	2.86	H	0.69	28.38
	25/0	1852.5	-14.33	19.38	10.40	2.83	H	0.49	26.94
		1880.0	-13.04	20.84	10.43	2.81	H	0.70	28.46
		1907.5	-13.97	20.02	10.47	2.86	H	0.58	27.63

Equivalent Isotropic Radiated Power Output Data (Band 2)

NOTES:

Effective Radiated Power Output Measurements by Substitution Method

according to ANSI/TIA/EIA-603-C-2004, Aug. 17, 2004:

The EUT was placed on a non-conductive styrofoam resin table 3-meters from the receive antenna. The receive antenna height and turntable rotation was adjusted for the highest reading on the receive spectrum analyzer. For 1 MHz BW signals, a peak detector is used, with RBW = VBW = 1 MHz. For 10 MHz BW signals, a peak detector is used, with RBW = VBW = 10 MHz. A half-wave dipole was substituted in place of the EUT. This dipole antenna was driven by a signal generator and the level of the signal generator was adjusted to obtain the same receive spectrum analyzer reading. The conducted power at the terminals of the Horn antenna is measured. The difference between the gain of the horn and an isotropic antenna is taken into consideration and the EIRP is recorded.

Also, we have done x, y, z planes in EUT and horizontal and vertical polarization in detecting antenna. The worst case of the EUT is x plane in LTE mode. Also worst case of detecting Antenna is horizontal polarization in LTE mode.

FCC Class II Permissive Change REPORT			www.hct.co.kr
Test Report No. HCTR1201FR06	Date of Issue: January 05, 2012	EUT Type: Cellular/PCS/AWS CDMA/ AWS LTE with Bluetooth/ WLAN	FCC ID: ZNFMS840

7.3 RADIATED SPURIOUS EMISSIONS

7.3.1 RADIATED SPURIOUS EMISSIONS (Band 2)

- ▣ OPERATING FREQUENCY : _____ 1909.30 MHz
- ▣ MEASURED OUTPUT POWER: _____ 28.51dBm = 0.709W
- ▣ MODULATION SIGNAL: _____ 1.4 MHz, 16-QAM
- ▣ DISTANCE: _____ 3 meters
- ▣ LIMIT: - (43 + 10 log₁₀ (W)) = _____ - 41.51 dBc

Ch	Freq (MHz)	Measured Level (dBm)	Ant. Gain (dBd)	Substitute Level (dBm)	C.L	Pol	ERP (dBm)	dBc
1907.5	3,815.00	-41.14	12.45	-43.37	5.02	V	-35.94	-64.45
	5,722.50	-50.74	12.71	-47.21	6.54	V	-41.04	-69.55
	7,630.00	-52.92	10.87	-40.01	7.78	H	-36.92	-65.43

- NOTES:**
1. Radiated Spurious Emission Measurements at 3 meters by Substitution Method according to ANSI/TIA/EIA-603-C-2004, Aug. 17, 2004:
 2. The magnitude of spurious emissions attenuated more than 20dB below the limit above 5th Harmonic for all channel.
 3. we have done x, y, z planes in EUT and horizontal and vertical polarization in detecting antenna.
 4. Worst case is 1 resource block.

7.3.2 RADIATED SPURIOUS EMISSIONS (Band 4)

- ▣ OPERATING FREQUENCY : 1732.50 MHz
- ▣ MEASURED OUTPUT POWER: 26.04 dBm = 0.401W
- ▣ MODULATION SIGNAL: 1.4 MHz QPSK
- ▣ DISTANCE: 3 meters
- ▣ LIMIT: - (43 + 10 log₁₀ (W)) = - 39.04 dBc

Ch	Freq (MHz)	Measured Level (dBm)	Ant. Gain (dBd)	Substitute Level (dBm)	C.L	Pol	ERP (dBm)	dBc
1732.50	3465.00	-49.06	12.05	-52.64	5.17	H	-45.76	-71.80
	5197.50	-40.76	12.49	-36.51	6.34	H	-30.36	-56.40
	6912.40	-36.61	11.60	-28.75	6.56	H	-23.71	-49.75

- NOTES:**
1. Radiated Spurious Emission Measurements at 3 meters by Substitution Method according to ANSI/TIA/EIA-603-C-2004, Aug. 17, 2004:
 2. The magnitude of spurious emissions attenuated more than 20dB below the limit above 5th Harmonic for all channel.
 3. we have done x, y, z planes in EUT and horizontal and vertical polarization in detecting antenna.
 4. Worst case is 6 resource block.