

# FCC LTE REPORT

## FCC Certification

**Applicant Name:**  
 LG Electronics MobileComm U.S.A., Inc.

**Date of Issue:**  
 June 30, 2017

**Address:**  
 1000 Sylvan Avenue, Englewood Cliffs NJ 07632

**Location:**  
 HCT CO., LTD.,  
 74, Seoicheon-ro 578beon-gil, Majang-myeon,  
 Icheon-si, Gyeonggi-do, 17383, Rep. of KOREA

**Report No.:** HCT-R-1706-F095  
**HCT FRN:** 0005866421

**FCC ID:** ZNFM700Z

**APPLICANT:** LG Electronics MobileComm U.S.A., Inc.

**FCC Model(s):** LG-M700Z  
**Additional FCC Model(s):** LGM700Z, M700Z, LG-M700DSK, LGM700DSK, M700DSK  
**EUT Type:** GSM/WCDMA/LTE Phone with Bluetooth4.2LE, WIFI802.11 b/g/n  
**FCC Classification:** Licensed Portable Transmitter Held to Ear (PCE)  
**FCC Rule Part(s):** §22, §2

Mode (MHz)	Tx Frequency (MHz)	Emission Designator	Modulation	ERP	
				Max. Power (W)	Max. Power (dBm)
LTE – Band5 (1.4)	824.7 – 848.3	1M10G7D	QPSK	0.069	18.39
		1M09W7D	16QAM	0.053	17.21
LTE – Band5 (3)	825.5 – 847.5	2M71G7D	QPSK	0.071	18.52
		2M69W7D	16QAM	0.054	17.31
LTE – Band5 (5)	826.5 – 846.5	4M51G7D	QPSK	0.068	18.30
		4M50W7D	16QAM	0.050	16.95
LTE – Band5 (10)	829.0 – 844.0	8M99G7D	QPSK	0.069	18.36
		8M97W7D	16QAM	0.052	17.12

The measurements shown in this report were made in accordance with the procedures specified in CFR47 section §2.947. I assume full responsibility for the accuracy and completeness of these measurements, and for the qualifications of all persons taking them.

HCT CO., LTD. Certifies that no party to this application has subject to a denial of Federal benefits that includes FCC benefits pursuant to section 5301 of the Anti-Drug Abuse Act of 1998, 21 U.S. C.853(a)



**Report prepared by : Jeong Ho Kim**  
**Engineer of Telecommunication Testing Center**



**Report approved by : Jong Seok Lee**  
**Manager of Telecommunication Testing Center**

This report only responds to the tested sample and may not be reproduced, except in full, without written approval of the HCT Co., Ltd.

## Version

TEST REPORT NO.	DATE	DESCRIPTION
HCT-R-1706-F095	June 30, 2017	- First Approval Report

---

# Table of Contents

1. GENERAL INFORMATION .....	4
2. INTRODUCTION .....	5
2.1. EUT DESCRIPTION.....	5
2.2. MEASURING INSTRUMENT CALIBRATION.....	5
2.3. TEST FACILITY .....	5
3. DESCRIPTION OF TESTS.....	6
3.1 ERP RADIATED POWER AND RADIATED SPURIOUS EMISSIONS .....	6
3.2 FREQUENCY RANGE .....	6
3.3 OCCUPIED BANDWIDTH. ....	8
3.4 SPURIOUS AND HARMONIC EMISSIONS AT ANTENNA TERMINAL.....	9
3.5 FREQUENCY STABILITY / VARIATION OF AMBIENT TEMPERATURE .....	10
4. LIST OF TEST EQUIPMENT .....	11
5. MEASUREMENT UNCERTAINTY .....	12
6. SUMMARY OF TEST RESULTS .....	13
7. SAMPLE CALCULATION.....	14
8. TEST DATA .....	15
8.1 EFFECTIVE RADIATED POWER (Band 5).....	15
8.2 RADIATED SPURIOUS EMISSIONS .....	17
8.2.1 RADIATED SPURIOUS EMISSIONS (1.4 MHz Band 5 LTE).....	17
8.2.2 RADIATED SPURIOUS EMISSIONS (3 MHz Band 5 LTE).....	18
8.2.3 RADIATED SPURIOUS EMISSIONS (5 MHz Band 5 LTE).....	19
8.2.4 RADIATED SPURIOUS EMISSIONS (10 MHz Band 5 LTE).....	20
8.3 OCCUPIED BANDWIDTH .....	21
8.4 CONDUCTED SPURIOUS EMISSIONS .....	22
8.4.1 BAND EDGE.....	22
8.5 FREQUENCY STABILITY / VARIATION OF AMBIENT TEMPERATURE .....	23
8.5.1 FREQUENCY STABILITY (1.4 MHz Band 5 LTE) .....	23
8.5.2 FREQUENCY STABILITY (3 MHz Band 5 LTE) .....	24
8.5.3 FREQUENCY STABILITY (5 MHz Band 5 LTE) .....	25
8.5.4 FREQUENCY STABILITY (10 MHz Band 5 LTE) .....	26
9. TEST PLOTS.....	27

# MEASUREMENT REPORT

## 1. GENERAL INFORMATION

**Applicant Name:** LG Electronics MobileComm U.S.A., Inc.

**Address:** 1000 Sylvan Avenue, Englewood Cliffs NJ 07632

**FCC ID:** ZNFM700Z

**Application Type:** Certification

**FCC Classification:** Licensed Portable Transmitter Held to Ear (PCE)

**FCC Rule Part(s):** §22, §2

**EUT Type:** GSM/WCDMA/LTE Phone with Bluetooth4.2LE, WIFI802.11 b/g/n

**FCC Model(s):** LG-M700Z

**Additional FCC Model(s):** LGM700Z, M700Z, LG-M700DSK, LGM700DSK, M700DSK

**Tx Frequency:** 824.7 MHz – 848.3 MHz (LTE – Band 5 (1.4 MHz))  
825.5 MHz – 847.5 MHz (LTE – Band 5 (3 MHz))  
826.5 MHz – 846.5 MHz (LTE – Band 5 (5 MHz))  
829.0 MHz – 844.0 MHz (LTE – Band 5 (10 MHz))

**Max. RF Output Power:** Band 5 (1.4 MHz) : 0.069 W (QPSK) (18.39 dBm)  
0.053 W (16-QAM) (17.21 dBm)  
Band 5 (3 MHz) : 0.071 W (QPSK) (18.52 dBm)  
0.054 W (16-QAM) (17.31 dBm)  
Band 5 (5 MHz) : 0.068 W (QPSK) (18.30 dBm)  
0.050 W (16-QAM) (16.95 dBm)  
Band 5 (10 MHz) : 0.069 W (QPSK) (18.36 dBm)  
0.052 W (16-QAM) (17.12 dBm)

**Emission Designator(s):** Band 5 (1.4 MHz) : 1M10G7D (QPSK) / 1M09W7D (16-QAM)  
Band 5 (3 MHz) : 2M71G7D (QPSK) / 2M69W7D (16-QAM)  
Band 5 (5 MHz) : 4M51G7D (QPSK) / 4M50W7D (16-QAM)  
Band 5 (10 MHz) : 8M99G7D (QPSK) / 8M97W7D (16-QAM)

**Date(s) of Tests:** April 25, 2017 ~ June 30, 2017

## **2. INTRODUCTION**

### **2.1. EUT DESCRIPTION**

The LG Electronics MobileComm U.S.A., Inc. LG-M700Z GSM/WCDMA/LTE Phone with Bluetooth4.2LE, WIFI802.11 b/g/n consists of LTE 5.

### **2.2. MEASURING INSTRUMENT CALIBRATION**

The measuring equipment, which was utilized in performing the tests documented herein, has been calibrated in accordance with the manufacturer's recommendations for utilizing calibration equipment, which is traceable to recognized national standards.

### **2.3. TEST FACILITY**

The Fully-anechoic chamber and conducted measurement facility used to collect the radiated data are located at the **74, Seoicheon-ro 578beon-gil, Majang-myeon, Icheon-si, Gyeonggi-do, 17383, Rep. of KOREA.**

### 3. DESCRIPTION OF TESTS

#### 3.1 ERP RADIATED POWER AND RADIATED SPURIOUS EMISSIONS

Note: ERP(Effective Radiated Power)

Test Procedure

Radiated emission measurements are performed in the Fully-anechoic chamber. The equipment under test is placed on a non-conductive table 3-meters away from the receive antenna in accordance with ANSI/TIA-603-D-2010 Clause 2.2.17. The turntable is rotated through 360 degrees, and the receiving antenna scans in order to determine the level of the maximized emission. The level and position of the maximized emission is recorded with the spectrum analyzer using a RMS detector.

A half wave dipole is then substituted in place of the EUT. For emissions above 1GHz, a horn antenna is substituted in place of the EUT. The substitute antenna is driven by a signal generator and the previously recorded signal was duplicated.

The power is calculated by the following formula;

$$P_{d(dBm)} = P_{g(dBm)} - \text{cable loss (dB)} + \text{antenna gain (dB)}$$

Where:  $P_d$  is the dipole equivalent power and  $P_g$  is the generator output power into the substitution antenna.

#### Radiated spurious emissions

: Frequency Range : 9 kHz ~ 10<sup>th</sup> Harmonics of highest channel fundamental frequency.

#### 3.2 FREQUENCY RANGE

§22.917(a): Cellular – Mobile Frequency Blocks

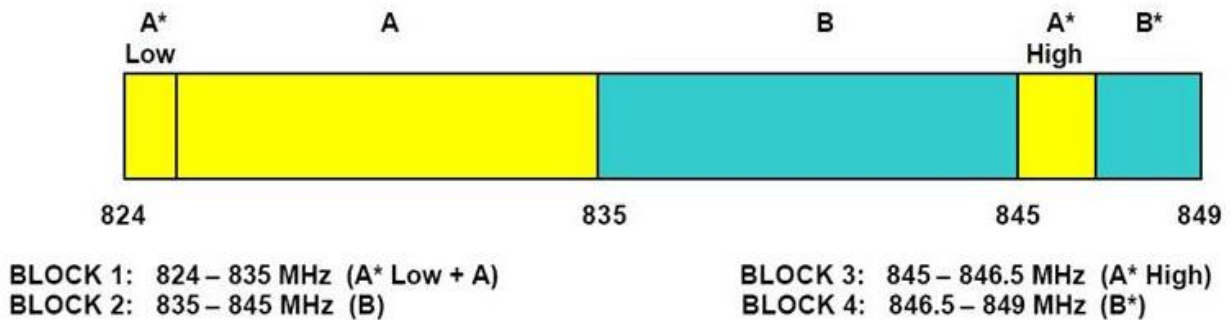

**5.1.1 Peak power measurements with a spectrum/signal analyzer or EMI receiver**

The following procedure can be used to determine the total peak output power.

- a) Set the RBW  $\geq$  OBW.
- b) Set VBW  $\geq 3 \times$  RBW.
- c) Set span  $\geq 2 \times$  RBW
- d) Sweep time = auto couple.
- e) Detector = peak.
- f) Ensure that the number of measurement points  $\geq$  span/RBW.
- g) Trace mode = max hold.
- h) Allow trace to fully stabilize.
- i) Use the peak marker function to determine the peak amplitude level.

**5.2.2 Procedures for use with a spectrum/signal analyzer when EUT cannot be configured to transmit continuously and sweep triggering/signal gating cannot be properly implemented**

If the EUT cannot be configured to transmit continuously (burst duty cycle  $< 98\%$ ), then one of the following procedures can be used. The selection of the applicable procedure will depend on the characteristics of the measured burst duty cycle.

Measure the burst duty cycle with a spectrum/signal analyzer or EMC receiver can be used in zero-span mode if the response time and spacing between bins on the sweep are sufficient to permit accurate measurement of the burst on/off time of the transmitted signal.

**5.2.2.2 Constant burst duty cycle**

If the measured burst duty cycle is constant (i.e., duty cycle variations are less than  $\pm 2$  percent), then:

- a) Set span to at least 1.5 times the OBW.
- b) Set RBW = 1-5% of the OBW, not to exceed 1 MHz.
- c) Set VBW  $\geq 3 \times$  RBW.
- d) Number of points in sweep  $\geq 2 \times$  span / RBW. (This gives bin-to-bin spacing  $\leq$  RBW/2, so that narrowband signals are not lost between frequency bins.)
- e) Sweep time = auto.
- f) Detector = RMS (power averaging).
- g) Set sweep trigger to "free run".
- h) Trace average at least 100 traces in power averaging (i.e., RMS) mode.
- i) Compute power by integrating the spectrum across the OBW of the signal using the instrument's band power measurement function with band limits set equal to the OBW band edges. If the instrument does not have a band power function, sum the spectrum levels (in power units) at intervals equal to the RBW extending across the entire OBW of the spectrum.
- j) Add  $10 \log (1/x)$ , where  $x$  is the duty cycle, to the measured power in order to compute the average power during the actual transmission times (because the measurement represents an average over both the on and off times of the transmission).

For example, add  $10 \log (1/0.25) = 6$  dB if the duty cycle is a constant 25%.

### 3.3 OCCUPIED BANDWIDTH.

#### Test set-up

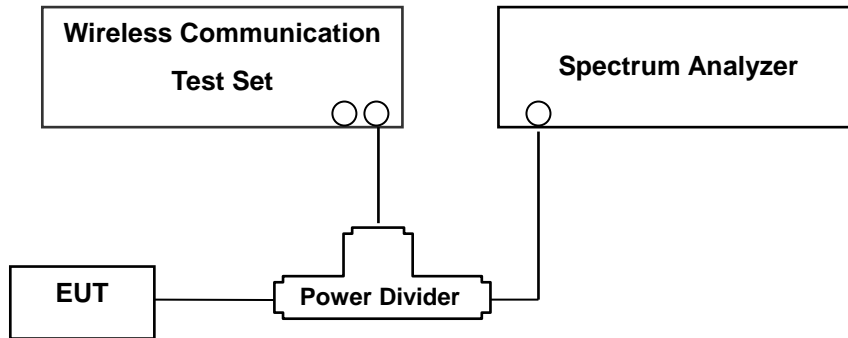

(Configuration of conducted Emission measurement)

The width of a frequency band such that, below the lower and above the upper frequency limits, the mean powers emitted are each equal to a specified percentage 0.5 % of the total mean power of a given emission.

#### Test Procedure

OBW is tested in accordance with KDB971168 D01 Power Meas License Digital Systems v02r02, October 17, 2014, Section 4.2.

The EUT makes a call to the communication simulator. The power was measured with R&S Spectrum Analyzer. All measurements were done at 3 channels(low, middle and high operational range.)

The conducted occupied bandwidth used the power splitter via EUT RF power connector between simulation base station and spectrum analyzer.

The communication simulator station system controlled a EUT to export maximum output power under transmission mode and specific channel frequency. Use OBW measurement function of Spectrum analyzer to measure 99 % occupied bandwidth



### 3.4 SPURIOUS AND HARMONIC EMISSIONS AT ANTENNA TERMINAL.

#### Test Procedure

Spurious and harmonic emissions at antenna terminal is tested in accordance with KDB971168 D01 Power Meas License Digital Systems v02r02, October 17, 2014, Section 6.0.

The level of the carrier and the various conducted spurious and harmonic frequencies is measured by means of a calibrated spectrum analyzer.

The EUT was setup to maximum output power at its lowest channel. The Resolution BW of the analyzer is set to 1 % of the emission bandwidth to show compliance with the -13 dBm limit, in the 1 MHz bands immediately outside and adjacent to the edge of the frequency block. The 1 MHz RBW was used to scan from 30 MHz to 10<sup>th</sup> Harmonics. A display line was placed at -13 dBm to show compliance. The high, lowest and a middle channel were tested for out of band measurements.

- Band Edge Requirement : In the 1MHz bands immediately outside and adjacent to the frequency block, a resolution bandwidth of at least 1 percent of the emission bandwidth of the fundamental emission of the transmitter may be employed to measure the out of band Emissions. Limit, -13dBm.

-

### 3.5 FREQUENCY STABILITY / VARIATION OF AMBIENT TEMPERATURE

#### Test Set-up

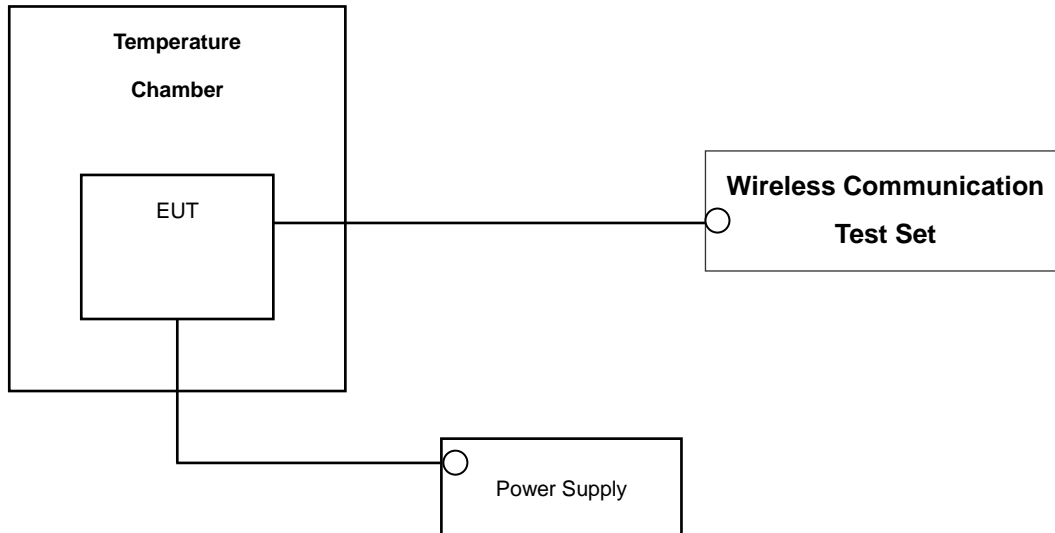

\* Nominal Operating Voltage

#### Test Procedure

Frequency stability is tested in accordance with ANSI/TIA-603-D-2010 section 2.2.2

The frequency stability of the transmitter is measured by:

- a.) **Temperature:** The temperature is varied from - 30 °C to + 50 °C using an environmental chamber.
- b.) **Primary Supply Voltage:** The primary supply voltage is varied from the end point to 100 % of the voltage normally at the input to the device or at the power supply terminals if cables are not normally supplied.

Specification — the frequency stability of the transmitter shall be maintained within  $\pm 0.00025\%$  ( $\pm 2.5$  ppm) of the center frequency.

#### Time Period and Procedure:

The carrier frequency of the transmitter is measured at room temperature (20°C to provide a reference).

1. The equipment is turned on in a "standby" condition for one minute before applying power to the transmitter. Measurement of the carrier frequency of the transmitter is made within one minute after applying power to the transmitter.
2. Frequency measurements are made at 10°C intervals ranging from -30°C to +50°C. A period of at least one half-hour is provided to allow stabilization of the equipment at each temperature level.

**NOTE: The EUT is tested down to the battery endpoint.**

## 4. LIST OF TEST EQUIPMENT

Manufacture	Model/ Equipment	Serial Number	Calibration Date	Calibration Interval	Calibration Due
REOHDE & SCHWARZ	SCU 18 / AMPLIFIER	10094	04/24/2017	Annual	04/24/2018
Wainwright	WHK1.2/15G-10EF/H.P.F	4	04/10/2017	Annual	04/10/2018
Wainwright	WHK3.3/18G-10EF/H.P.F	2	04/10/2017	Annual	04/10/2018
Hewlett Packard	11667B / Power Splitter(DC~26.5 GHz)	11275	05/04/2017	Annual	05/04/2018
Agilent	E3632A/DC Power Supply	KR75303243	07/12/2016	Annual	07/12/2017
Schwarzbeck	UHAP/ Dipole Antenna	557	03/31/2017	Biennial	03/31/2019
Schwarzbeck	UHAP/ Dipole Antenna	558	03/31/2017	Biennial	03/31/2019
ESPEC	SU-642 / Chamber	0093008124	03/31/2017	Annual	03/31/2018
Schwarzbeck	BBHA 9120D/ Horn Antenna(1~18GHz)	147	09/09/2016	Biennial	09/09/2018
Schwarzbeck	BBHA 9120D/ Horn Antenna(1~18GHz)	1298	10/14/2016	Biennial	10/14/2018
Schwarzbeck	BBHA 9170/ Horn Antenna(15~40GHz)	BBHA9170342	04/25/2017	Biennial	04/25/2019
Schwarzbeck	BBHA 9170/ Horn Antenna(15~40GHz)	BBHA9170124	04/25/2017	Biennial	04/25/2019
Agilent	N9020A/Signal Analyzer(10Hz~26.5GHz)	MY52090906	06/01/2017	Annual	06/01/2018
Hewlett Packard	8493C/ATTENUATOR(20dB)	17280	06/22/2017	Annual	06/22/2018
REOHDE & SCHWARZ	FSV40-N/Spectrum Analyzer	101068-SZ	09/23/2016	Annual	09/23/2017
Agilent	8960 (E5515C)/ Base Station	MY48360800	10/19/2016	Annual	10/19/2017
Schwarzbeck	FMZB1513/ Loop Antenna(9kHz~30MHz)	1513-175	04/06/2017	Biennial	04/06/2019
Schwarzbeck	VULB9160/ Bilog Antenna	3150	09/30/2016	Biennial	09/30/2018
Schwarzbeck	VULB9160/ Bilog Antenna	3368	10/14/2016	Biennial	10/14/2018
Anritsu Corp.	MT8820C/Wideband Radio Communication Tester	6200863156	02/15/2017	Annual	02/15/2018
Anritsu Corp.	MT8820C/Wideband Radio Communication Tester	6201026545	02/13/2017	Annual	02/13/2018
REOHDE & SCHWARZ	SMB100A/ SIGNAL GENERATOR (100kHz~40GHz)	177633	07/18/2016	Annual	07/18/2017

## 5. MEASUREMENT UNCERTAINTY

The measurement uncertainties shown below were calculated in accordance with the requirements of ANSI C63.4:2014.

All measurement uncertainty values are shown with a coverage factor of  $k = 2$  to indicate a 95 % level of confidence. The measurement data shown herein meets or exceeds the  $U_{\text{CISPR}}$  measurement uncertainty values specified in CISPR 16-4-2 and, thus, can be compared directly to specified limits to determine compliance.

Parameter	Expanded Uncertainty ( $\pm$ dB)
Conducted Disturbance (150 kHz ~ 30 MHz)	1.82
Radiated Disturbance (9 kHz ~ 30 MHz)	3.40
Radiated Disturbance (30 MHz ~ 1 GHz)	4.80
Radiated Disturbance (1 GHz ~ 18 GHz)	6.07

## 6. SUMMARY OF TEST RESULTS

FCC Part Section(s)	Test Description	Test Limit	Test Condition	Test Result
2.1049	Occupied Bandwidth	N/A	CONDUCTED	PASS
2.1051, 22.917(a)	Band Edge / Spurious and Harmonic Emissions at Antenna Terminal.	$< 43 + 10\log_{10}(P[\text{Watts}])$ at Band Edge and for all out-of-band emissions		PASS
2.1046	* Conducted Output Power	N/A		PASS
2.1055, 22.355	Frequency stability / variation of ambient temperature	$< 2.5$ ppm		PASS
22.913(a)(2)	Effective Radiated Power (Band 5)	$< 7$ Watts max. ERP	RADIATED	PASS
2.1053, 22.917(a)	Radiated Spurious and Harmonic Emissions	$< 43 + 10\log_{10}(P[\text{Watts}])$ for all out-of band emissions		PASS

\*: See SAR Report

## 7. SAMPLE CALCULATION

### A. ERP Sample Calculation

Mode	Ch./ Freq.		Measured Level(dBm)	Substitute LEVEL(dBm)	Ant. Gain (dBd)	C.L	Pol.	Limit W	ERP	
	channel	Freq.(MHz)							W	dBm
LTE Band5	20525	836.50	-6.73	40.89	-10.54	0.96	V	< 7.00	0.869	29.39

**ERP = Substitute LEVEL(dBm) + Ant. Gain – CL(Cable Loss)**

- 1) The EUT mounted on a wooden tripod is 2.5 meter above test site ground level.
- 2) During the test , the turn table is rotated and the antenna height is found.
- 3) Record the field strength meter's level.
- 4) Replace the EUT with dipole/Horn antenna that is connected to a calibrated signal generator.
- 5) Increase the signal generator output till the field strength meter's level is equal to the item (3).
- 6) The signal generator output level with Ant. Gain and cable loss are the rating of effective radiated power (ERP).

## B. Emission Designator

### QPSK Modulation

#### **5MHz Bandwidth**

**Emission Designator = 4M48G7D**

LTE BW = 4.48 MHz

G = Phase Modulation

7 = Quantized/Digital Info

D = Data transmission; telemetry; telecommand

#### **10MHz Bandwidth**

**Emission Designator = 8M95G7D**

LTE BW = 8.95 MHz

G = Phase Modulation

7 = Quantized/Digital Info

D = Data transmission; telemetry; telecommand

### 16QAM Modulation

#### **5MHz Bandwidth**

**Emission Designator = 4M48W7D**

LTE BW = 4.48 MHz

W = main carrier modulated in a combination of two or more of the following modes;  
amplitude, angle, pulse

7 = Quantized/Digital Info

D = Data transmission; telemetry; telecommand

#### **10MHz Bandwidth**

**Emission Designator = 8M95W7D**

LTE BW = 8.95 MHz

W = main carrier modulated in a combination of two or more of the following modes;  
amplitude, angle, pulse

7 = Quantized/Digital Info

D = Data transmission; telemetry; telecommand

## 8. TEST DATA

### 8.1 EFFECTIVE RADIATED POWER (Band 5)

Freq (MHz)	Bandwidth	Modulation	Measured Level (dBm)	Substitute Level (dBm)	Ant. Gain(dBd)	C.L	Pol	Limit	ERP	
								W	W	dBm
824.7	1.4 MHz	QPSK	-32.36	29.86	-10.59	1.31	V	< 7.00	0.063	17.96
		16-QAM	-33.53	28.69	-10.59	1.31	V		0.048	16.79
836.5		QPSK	-32.31	30.25	-10.54	1.32	V		0.069	18.39
		16-QAM	-33.49	29.07	-10.54	1.32	V		0.053	17.21
848.3		QPSK	-32.60	29.46	-10.49	1.33	V		0.058	17.64
		16-QAM	-34.19	27.87	-10.49	1.33	V		0.040	16.05

**Effective Radiated Power Data (1.4 MHz Band 5 LTE)**

Note: All of RB size has been tested for emissions and ERP, with the 1RB configuration observed as the worst case

Freq (MHz)	Bandwidth	Modulation	Measured Level (dBm)	Substitute Level (dBm)	Ant. Gain(dBd)	C.L	Pol	Limit	ERP	
								W	W	dBm
825.5	3 MHz	QPSK	-32.13	30.14	-10.59	1.31	V	< 7.00	0.067	18.24
		16-QAM	-33.46	28.81	-10.59	1.31	V		0.049	16.91
836.5		QPSK	-32.18	30.38	-10.54	1.32	V		0.071	18.52
		16-QAM	-33.39	29.17	-10.54	1.32	V		0.054	17.31
847.5		QPSK	-32.43	29.66	-10.49	1.33	V		0.061	17.84
		16-QAM	-33.85	28.24	-10.49	1.33	V		0.044	16.42

**Effective Radiated Power Data (3 MHz Band 5 LTE)**

Note: All of RB size has been tested for emissions and ERP, with the 1RB configuration observed as the worst case

Freq (MHz)	Bandwidth	Modulation	Measured Level (dBm)	Substitute Level (dBm)	Ant. Gain(dBd)	C.L	Pol	Limit	ERP	
								W	W	dBm
826.5	5 MHz	QPSK	-32.26	30.05	-10.58	1.31	V	< 7.00	0.065	18.16
		16-QAM	-33.47	28.84	-10.58	1.31	V		0.050	16.95
836.5		QPSK	-32.40	30.16	-10.54	1.32	V		0.068	18.30
		16-QAM	-33.77	28.79	-10.54	1.32	V		0.049	16.93
846.5		QPSK	-32.56	29.57	-10.50	1.33	V		0.059	17.74
		16-QAM	-33.78	28.35	-10.50	1.33	V		0.045	16.52

**Effective Radiated Power Data (5 MHz Band 5 LTE)**

Note: All of RB size has been tested for emissions and ERP, with the 1RB configuration observed as the worst case

Freq (MHz)	Bandwidth	Modulation	Measured Level (dBm)	Substitute Level (dBm)	Ant. Gain(dBd)	C.L	Pol	Limit	ERP	
								W	W	dBm
829.0	10 MHz	QPSK	-32.21	30.18	-10.57	1.31	V	< 7.00	0.068	18.30
		16-QAM	-33.63	28.76	-10.57	1.31	V		0.049	16.88
836.5		QPSK	-32.34	30.22	-10.54	1.32	V		0.069	18.36
		16-QAM	-33.58	28.98	-10.54	1.32	V		0.052	17.12
844.0		QPSK	-32.37	29.89	-10.51	1.33	V		0.064	18.05
		16-QAM	-33.47	28.79	-10.51	1.33	V		0.050	16.95

**Effective Radiated Power Data (10 MHz Band 5 LTE)**

Note: All of RB size has been tested for emissions and ERP, with the 1RB configuration observed as the worst case

**NOTES:**

Effective Radiated Power Output Measurements by Substitution Method

according to ANSI/TIA/EIA-603-D-2010 June 24, 2010:

The EUT was placed on a non-conductive styrofoam resin table 3-meters from the receive antenna. The receive antenna height and turntable rotation was adjusted for the highest reading on the receive spectrum analyzer. For LTE signals, RBW = 1-5% of the OBW, not to exceed 1MHz, VBW ≥ 3 x RBW, Detector = RMS.

A half-wave dipole was substituted in place of the EUT. This dipole antenna was driven by a signal generator and the level of the signal generator was adjusted to obtain the same receive spectrum analyzer reading. The conducted power at the terminals of the dipole is measured. The ERP is recorded.

Also, we have done x, y, z planes in EUT and horizontal and vertical polarization in detecting antenna. The worst case of the EUT is y plane in LTE mode. Also worst case of detecting Antenna is vertical polarization in LTE mode.



## 8.2 RADIATED SPURIOUS EMISSIONS

### 8.2.1 RADIATED SPURIOUS EMISSIONS (1.4 MHz Band 5 LTE)

- ▣ OPERATING FREQUENCY: 836.50 MHz
- ▣ MEASURED OUTPUT POWER: 18.39 dBm = 0.069 W
- ▣ MODULATION SIGNAL: 1.4 MHz QPSK
- ▣ DISTANCE: 3 meters
- ▣ LIMIT:  $43 + 10 \log_{10}(W) =$  21.39 dBc

Ch	Freq (MHz)	Measured Level (dBm)	Ant. Gain (dBd)	Substitute Level (dBm)	C.L	Pol	ERP (dBm)	dBc
20407 (824.7)	1,649.40	-55.90	9.16	-68.32	1.88	V	-61.04	79.43
	2,474.10	-54.90	10.93	-63.89	2.33	H	-55.29	73.68
	3,298.80	-56.01	11.94	-65.28	2.72	V	-56.06	74.45
20525 (836.5)	1,673.00	-56.98	9.23	-69.45	1.90	H	-62.12	80.51
	2,509.50	-55.40	10.96	-64.66	2.36	V	-56.06	74.45
	3,346.00	-56.20	12.04	-65.77	2.74	V	-56.47	74.86
20643 (848.3)	1,696.60	-55.72	9.32	-68.18	1.91	V	-60.77	79.16
	2,544.90	-56.77	10.99	-65.76	2.39	H	-57.16	75.55
	3,393.20	-56.55	12.14	-66.02	2.77	V	-56.65	75.04

- NOTES:**
1. Radiated Spurious Emission Measurements at 3 meters by Substitution Method according to ANSI/TIA/EIA-603-D-2010 June 24, 2010:
  2. We are performed all frequency to 10<sup>th</sup> harmonics from 9 kHz. Measurements above show only up to 3 maximum emissions noted, or would be lesser if no specific emissions from the EUT are recorded (ie: margin > 20 dB from the applicable limit) and considered that's already beyond the background noise floor.
  3. we have done x, y, z planes in EUT and horizontal and vertical polarization in detecting antenna.
  4. All of RB size has been tested for emissions and ERP, with the 1RB configuration observed as the worst case
  5. We are performed 16QAM and QPSK modulations. The worst case data are reported in the table above.

**8.2.2 RADIATED SPURIOUS EMISSIONS (3 MHz Band 5 LTE)**

- ▣ OPERATING FREQUENCY: 836.50 MHz
- ▣ MEASURED OUTPUT POWER: 18.52 dBm = 0.071 W
- ▣ MODULATION SIGNAL: 3 MHz QPSK
- ▣ DISTANCE: 3 meters
- ▣ LIMIT:  $43 + 10 \log_{10}(W) =$  31.52 dBc

Ch	Freq (MHz)	Measured Level (dBm)	Ant. Gain (dBd)	Substitute Level (dBm)	C.L	Pol	ERP (dBm)	dBc
20415 (825.5)	1,651.00	-54.80	9.16	-67.22	1.88	V	-59.94	78.46
	2,476.50	-51.68	10.92	-60.78	2.33	V	-52.19	70.71
	3,302.00	-55.63	11.94	-64.89	2.72	V	-55.67	74.19
20525 (836.5)	1,673.00	-56.92	9.23	-69.39	1.90	V	-62.06	80.58
	2,509.50	-53.19	10.96	-62.45	2.36	V	-53.85	72.37
	3,346.00	-56.40	12.03	-65.96	2.74	V	-56.67	75.19
20635 (847.5)	1,695.00	-55.51	9.30	-67.96	1.91	V	-60.57	79.09
	2,542.50	-52.51	10.98	-61.37	2.39	V	-52.78	71.30
	3,390.00	-56.68	12.13	-66.22	2.77	H	-56.86	75.38

- NOTES:**
1. Radiated Spurious Emission Measurements at 3 meters by Substitution Method according to ANSI/TIA/EIA-603-D-2010 June 24, 2010:
  2. We are performed all frequency to 10<sup>th</sup> harmonics from 9 kHz. Measurements above show only up to 3 maximum emissions noted, or would be lesser if no specific emissions from the EUT are recorded (ie: margin > 20 dB from the applicable limit) and considered that's already beyond the background noise floor.
  3. we have done x, y, z planes in EUT and horizontal and vertical polarization in detecting antenna.
  4. All of RB size has been tested for emissions and ERP, with the 1RB configuration observed as the worst case
  5. We are performed 16QAM and QPSK modulations. The worst case data are reported in the table above.

**8.2.3 RADIATED SPURIOUS EMISSIONS (5 MHz Band 5 LTE)**

- ▣ OPERATING FREQUENCY: 836.50 MHz
- ▣ MEASURED OUTPUT POWER: 18.30 dBm = 0.068 W
- ▣ MODULATION SIGNAL: 5 MHz QPSK
- ▣ DISTANCE: 3 meters
- ▣ LIMIT:  $43 + 10 \log_{10}(W) =$  31.30 dBc

Ch	Freq (MHz)	Measured Level (dBm)	Ant. Gain (dBd)	Substitute Level (dBm)	C.L	Pol	ERP (dBm)	dBc
20425 (826.5)	1,653.00	-57.41	9.17	-69.87	1.88	V	-62.58	80.88
	2,479.50	-53.46	10.92	-62.72	2.33	V	-54.13	72.43
	3,306.00	-56.56	11.95	-65.83	2.72	V	-56.60	74.90
20525 (836.5)	1,673.00	-57.14	9.23	-69.61	1.90	H	-62.28	80.58
	2,509.50	-53.17	10.96	-62.43	2.36	V	-53.83	72.13
	3,346.00	-55.88	10.03	-63.44	2.74	H	-56.15	74.45
20625 (846.5)	1,693.00	-56.21	9.31	-68.69	1.91	V	-61.29	79.59
	2,539.50	-52.39	10.98	-61.17	2.38	V	-52.57	70.87
	3,386.00	-56.43	12.11	-65.97	2.77	V	-56.63	74.93

- NOTES:**
1. Radiated Spurious Emission Measurements at 3 meters by Substitution Method according to ANSI/TIA/EIA-603-D-2010 June 24, 2010:
  2. We are performed all frequency to 10<sup>th</sup> harmonics from 9 kHz. Measurements above show only up to 3 maximum emissions noted, or would be lesser if no specific emissions from the EUT are recorded (ie: margin > 20 dB from the applicable limit) and considered that's already beyond the background noise floor.
  3. we have done x, y, z planes in EUT and horizontal and vertical polarization in detecting antenna.
  4. All of RB size has been tested for emissions and ERP, with the 1RB configuration observed as the worst case
  5. We are performed 16QAM and QPSK modulations. The worst case data are reported in the table above.

**8.2.4 RADIATED SPURIOUS EMISSIONS (10 MHz Band 5 LTE)**

- ▣ OPERATING FREQUENCY: 836.50 MHz
- ▣ MEASURED OUTPUT POWER: 18.36 dBm = 0.069 W
- ▣ MODULATION SIGNAL: 10 MHz QPSK
- ▣ DISTANCE: 3 meters
- ▣ LIMIT:  $43 + 10 \log_{10}(W) =$  31.36 dBc

Ch	Freq (MHz)	Measured Level (dBm)	Ant. Gain (dBd)	Substitute Level (dBm)	C.L	Pol	ERP (dBm)	dBc
20450 (829.0)	1658.00	-57.10	9.18	-69.64	1.88	V	-62.34	80.70
	2487.00	-53.80	10.93	-62.85	2.34	V	-54.26	72.62
	3316.00	-56.64	11.96	-65.95	2.71	V	-56.70	75.06
20525 (836.5)	1673.00	-57.10	9.23	-69.57	1.90	V	-62.24	80.60
	2509.50	-50.62	10.96	-59.88	2.36	V	-51.28	69.64
	3346.00	-56.41	10.03	-63.97	2.74	V	-56.68	75.04
20600 (844.0)	1688.00	-56.96	9.28	-69.45	1.91	V	-62.08	80.44
	2532.00	-49.79	10.98	-59.04	2.38	V	-50.44	68.80
	3376.00	-56.64	12.10	-66.25	2.77	V	-56.92	75.28

- NOTES:**
1. Radiated Spurious Emission Measurements at 3 meters by Substitution Method according to ANSI/TIA/EIA-603-D-2010 June 24, 2010:
  2. We are performed all frequency to 10<sup>th</sup> harmonics from 9 kHz. Measurements above show only up to 3 maximum emissions noted, or would be lesser if no specific emissions from the EUT are recorded (ie: margin > 20 dB from the applicable limit) and considered that's already beyond the background noise floor.
  3. we have done x, y, z planes in EUT and horizontal and vertical polarization in detecting antenna.
  4. All of RB size has been tested for emissions and ERP, with the 1RB configuration observed as the worst case
  5. We are performed 16QAM and QPSK modulations. The worst case data are reported in the table above.

### 8.3 OCCUPIED BANDWIDTH

Band	Band Width	Frequency (MHz)	Modulation	Resource Block Size	Resource Block Offset	Data ( MHz )
5	1.4 MHz	836.5	QPSK	6	0	1.0954
			16-QAM	6	0	1.0944
	3 MHz		QPSK	15	0	2.7065
			16-QAM	15	0	2.6940
	5 MHz		QPSK	25	0	4.5053
			16-QAM	25	0	4.4953
	10 MHz		QPSK	50	0	8.9854
			16-QAM	50	0	8.9655

- Plots of the EUT's Occupied Bandwidth are shown Page 28 ~ 31.

### 8.4 CONDUCTED SPURIOUS EMISSIONS

■ FACTORS FOR FREQUENCY

Frequency Range (GHz)	Factor [dB]
0.03 – 1	25.270
1 – 5	27.976
5 – 10	28.591
10 – 15	29.116
15 – 20	29.489
Above 20	30.131

**NOTES:**

Factor(dB) = Cable Loss + Attenuator + Power Splitter

Band	Band Width (MHz)	Frequency (MHz)	Frequency of Maximum Harmonic (GHz)	Factor (dB)	Measurement Maximum Data (dBm)	Result (dBm)	Limit (dBm)
5	1.4	824.7	3.7074	27.976	-67.052	-39.076	-13.00
		836.5	3.6995	27.976	-66.847	-38.871	
		848.3	3.7099	27.976	-67.110	-39.134	
	3	825.5	3.6870	27.976	-67.370	-39.394	
		836.5	3.7000	27.976	-67.182	-39.206	
		847.5	3.6910	27.976	-66.992	-39.016	
	5	826.5	3.6970	27.976	-67.172	-39.196	
		836.5	3.7244	27.976	-67.258	-39.282	
		846.5	3.6965	27.976	-66.718	-38.742	
	10	829.0	3.7224	27.976	-67.167	-39.191	
		836.5	3.6955	27.976	-67.370	-39.394	
		844.0	3.6845	27.976	-67.102	-39.126	

**NOTES:**

1. Conducted Spurious Emissions was Tested QPSK Modulation, Resource Block Size 1 and Resource Block Offset 0
2. Result (dBm) = Measurement Maximum Data (dBm) + Factor (dB)

- Plots of the EUT's Conducted Spurious Emissions are shown Page 44 ~ 49.

#### 8.4.1 BAND EDGE

- Plots of the EUT's Band Edge are shown Page 32 ~ 43.

## 8.5 FREQUENCY STABILITY / VARIATION OF AMBIENT TEMPERATURE

### 8.5.1 FREQUENCY STABILITY (1.4 MHz Band 5 LTE)

- ▣ OPERATING FREQUENCY: 836,500,000 Hz
- ▣ CHANNEL: 20525 (1.4 MHz)
- ▣ REFERENCE VOLTAGE: 3.85 VDC
- ▣ DEVIATION LIMIT: ± 0.000 25 % or 2.5 ppm

Voltage (%)	Power (VDC)	Temp. (°C)	Frequency (Hz)	Frequency Error (Hz)	Deviation (%)	ppm
100%	3.85	+20(Ref)	836 500 002	0.0	0.000 000	0.000
100%		-30	836 500 001	-1.8	0.000 000	-0.002
100%		-20	836 500 004	1.7	0.000 000	0.002
100%		-10	836 500 000	-2.5	0.000 000	-0.003
100%		0	836 500 000	-2.7	0.000 000	-0.003
100%		+10	836 500 000	-2.1	0.000 000	-0.003
100%		+30	836 499 999	-3.2	0.000 000	-0.004
100%		+40	836 500 000	-2.1	0.000 000	-0.003
100%		+50	836 499 998	-4.2	-0.000 001	-0.005
Batt. Endpoint		3.40	+20	836 500 000	-2.6	0.000 000

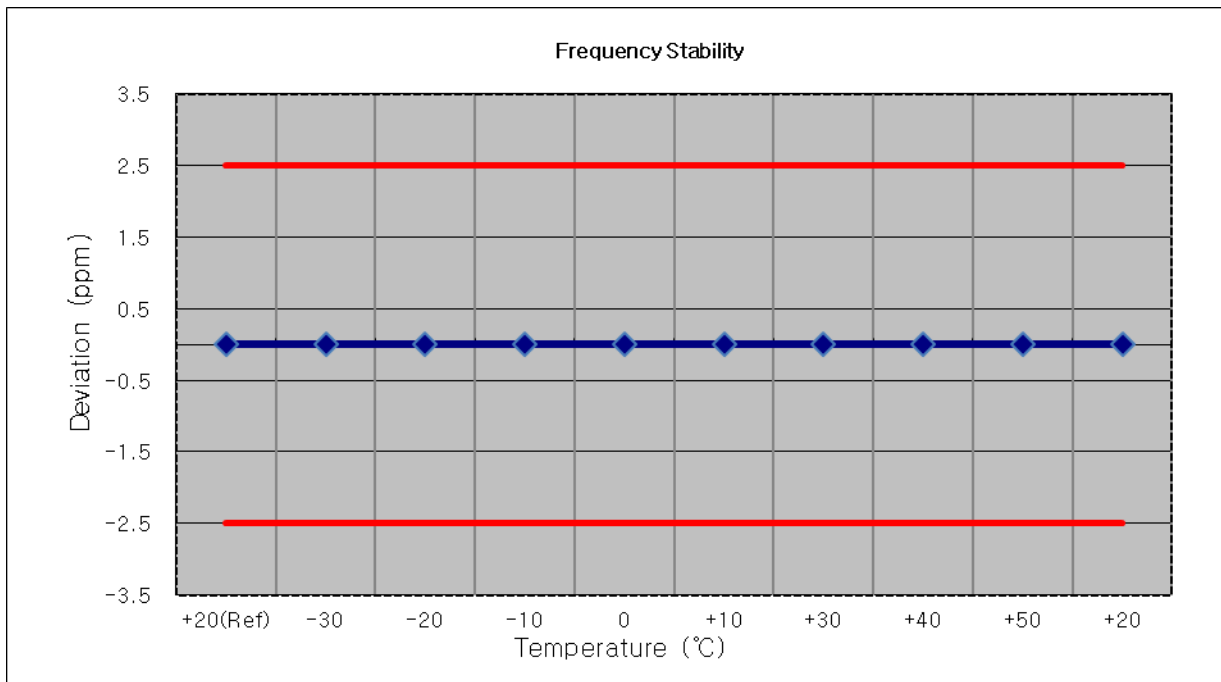

**8.5.2 FREQUENCY STABILITY (3 MHz Band 5 LTE)**

- ▣ OPERATING FREQUENCY: 836,500,000 Hz
- ▣ CHANNEL: 20525 (3 MHz)
- ▣ REFERENCE VOLTAGE: 3.85 VDC
- ▣ DEVIATION LIMIT: ± 0.000 25 % or 2.5 ppm

Voltage (%)	Power (VDC)	Temp. (°C)	Frequency (Hz)	Frequency Error (Hz)	Deviation (%)	ppm
100%	3.85	+20(Ref)	836 499 996	0.0	0.000 000	0.000
100%		-30	836 499 992	-3.7	0.000 000	-0.004
100%		-20	836 499 995	-1.3	0.000 000	-0.002
100%		-10	836 499 993	-3.2	0.000 000	-0.004
100%		0	836 499 993	-2.7	0.000 000	-0.003
100%		+10	836 499 999	2.6	0.000 000	0.003
100%		+30	836 499 999	2.9	0.000 000	0.003
100%		+40	836 499 999	2.8	0.000 000	0.003
100%		+50	836 499 992	-3.9	0.000 000	-0.005
Batt. Endpoint		3.40	+20	836 499 992	-3.9	0.000 000

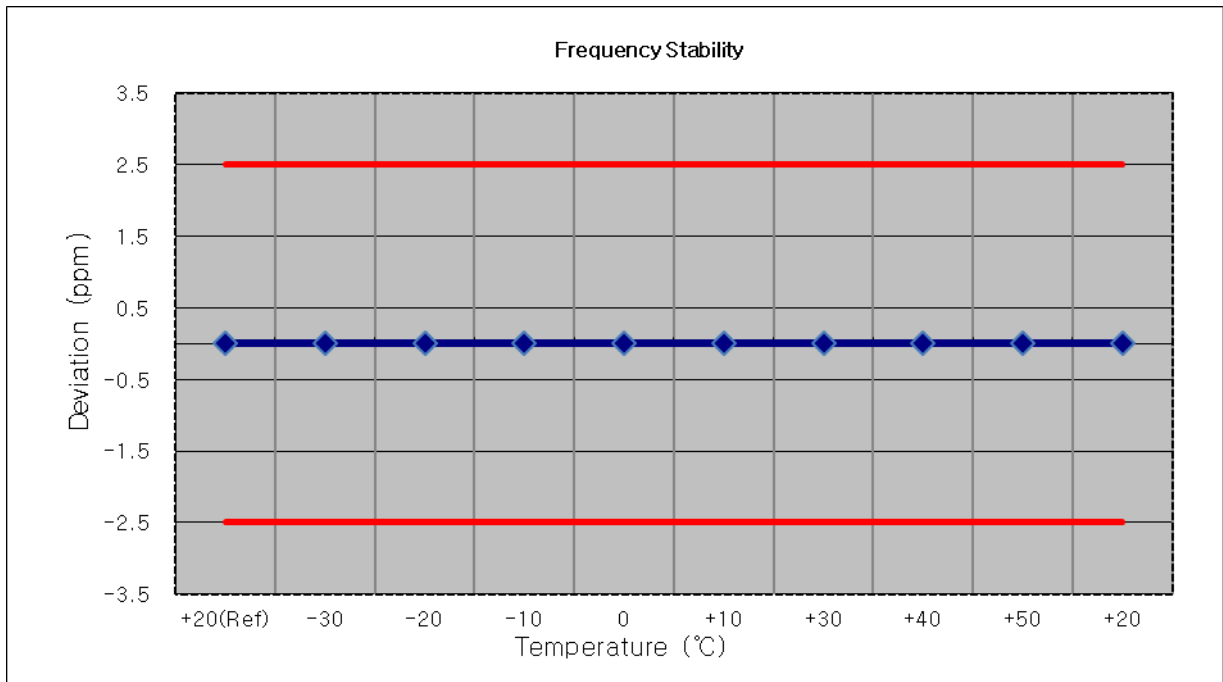



**8.5.3 FREQUENCY STABILITY (5 MHz Band 5 LTE)**

- ▣ OPERATING FREQUENCY: 836,500,000 Hz
- ▣ CHANNEL: 20525 (5 MHz)
- ▣ REFERENCE VOLTAGE: 3.85 VDC
- ▣ DEVIATION LIMIT: ± 0.000 25 % or 2.5 ppm

Voltage (%)	Power (VDC)	Temp. (°C)	Frequency (Hz)	Frequency Error (Hz)	Deviation (%)	ppm
100%	3.85	+20(Ref)	836 499 998	0.0	0.000 000	0.000
100%		-30	836 499 999	1.4	0.000 000	0.002
100%		-20	836 499 994	-3.2	0.000 000	-0.004
100%		-10	836 499 996	-1.6	0.000 000	-0.002
100%		0	836 499 994	-3.4	0.000 000	-0.004
100%		+10	836 499 995	-2.8	0.000 000	-0.003
100%		+30	836 499 995	-2.2	0.000 000	-0.003
100%		+40	836 499 995	-2.7	0.000 000	-0.003
100%		+50	836 499 996	-1.8	0.000 000	-0.002
Batt. Endpoint	3.40	+20	836 500 000	2.2	0.000 000	0.003

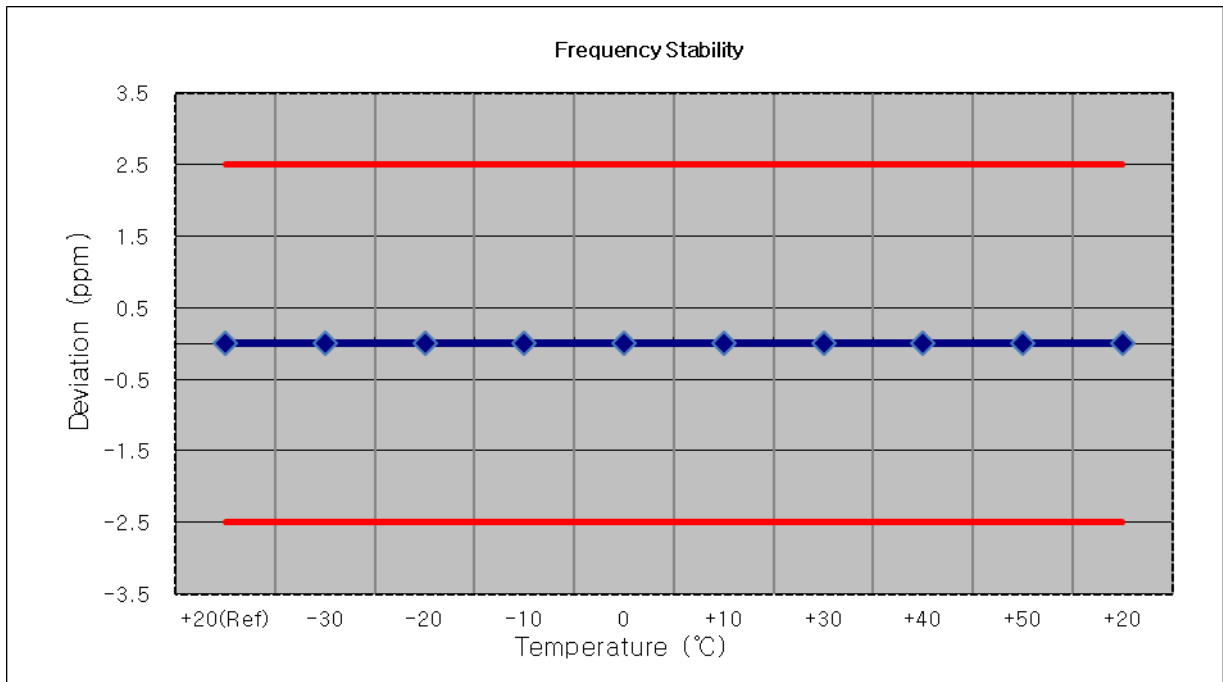

**8.5.4 FREQUENCY STABILITY (10 MHz Band 5 LTE)**

- ▣ OPERATING FREQUENCY: 836,500,000 Hz
- ▣ CHANNEL: 20525 (10 MHz)
- ▣ REFERENCE VOLTAGE: 3.85 VDC
- ▣ DEVIATION LIMIT: ± 0.000 25 % or 2.5 ppm

Voltage (%)	Power (VDC)	Temp. (°C)	Frequency (Hz)	Frequency Error (Hz)	Deviation (%)	ppm
100%	3.85	+20(Ref)	836 499 997	0.0	0.000 000	0.000
100%		-30	836 500 000	2.8	0.000 000	0.003
100%		-20	836 499 999	2.2	0.000 000	0.003
100%		-10	836 499 994	-3.2	0.000 000	-0.004
100%		0	836 499 994	-2.7	0.000 000	-0.003
100%		+10	836 499 994	-3.2	0.000 000	-0.004
100%		+30	836 499 992	-4.7	-0.000 001	-0.006
100%		+40	836 499 994	-3.4	0.000 000	-0.004
100%		+50	836 499 993	-3.8	0.000 000	-0.005
Batt. Endpoint		3.40	+20	836 499 994	-2.9	0.000 000

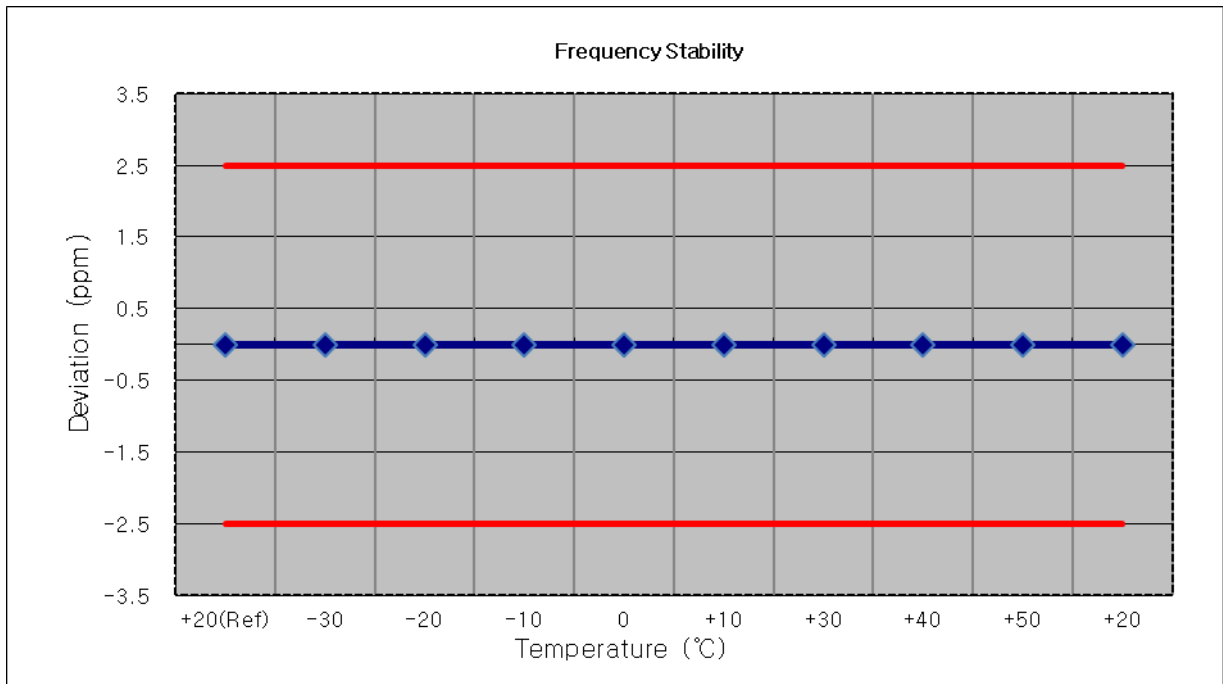

## 9. TEST PLOTS

BAND 5. Occupied Bandwidth Plot (1.4M BW Ch.20525 QPSK\_RB6\_0)

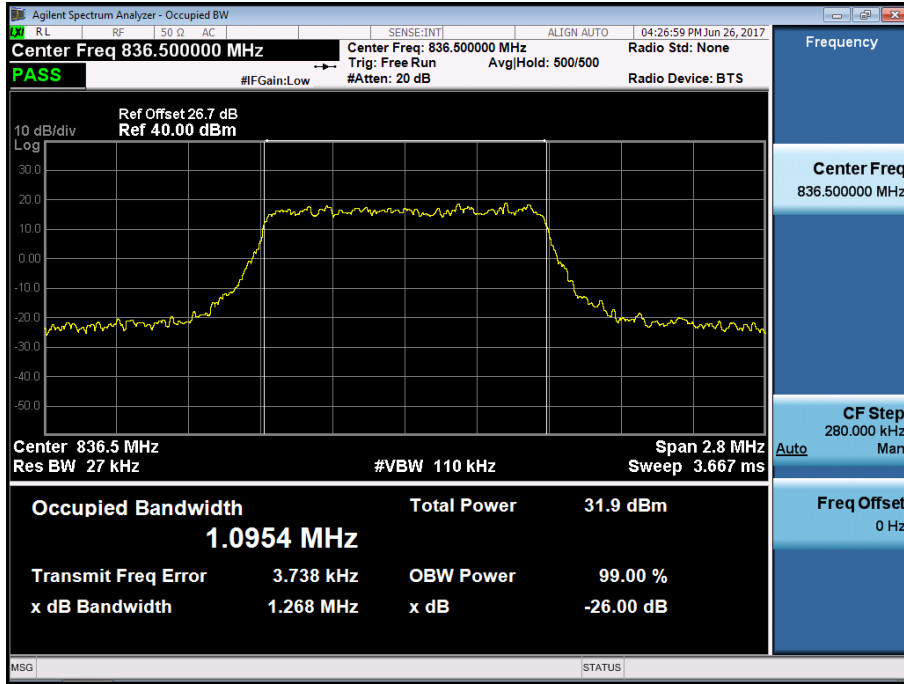

BAND 5. Occupied Bandwidth Plot (1.4M BW Ch.20525 16QAM\_RB6\_0)

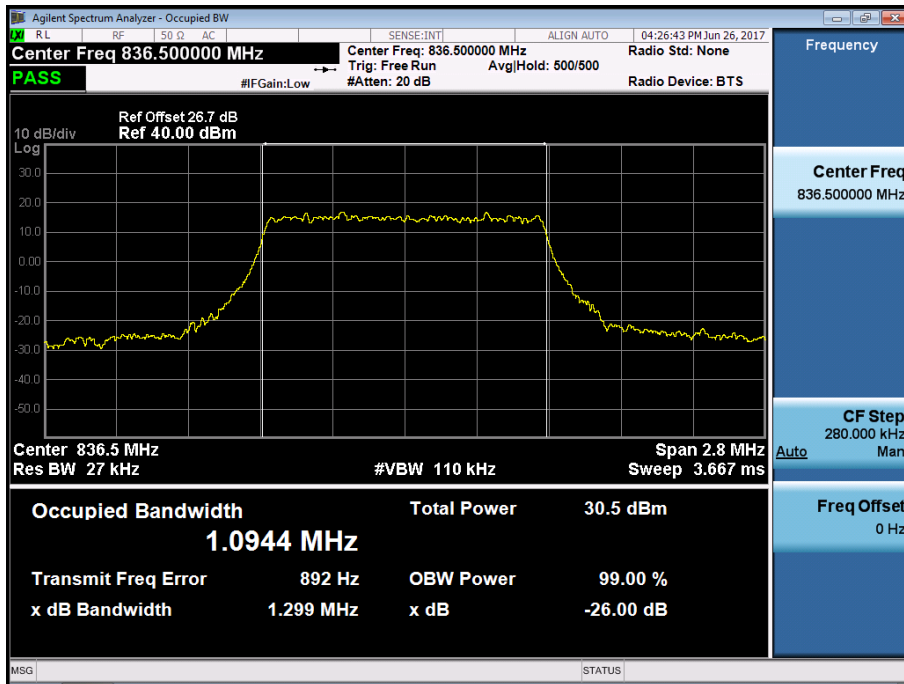

BAND 5. Occupied Bandwidth Plot (3M BW Ch.20525 QPSK\_RB15\_0)

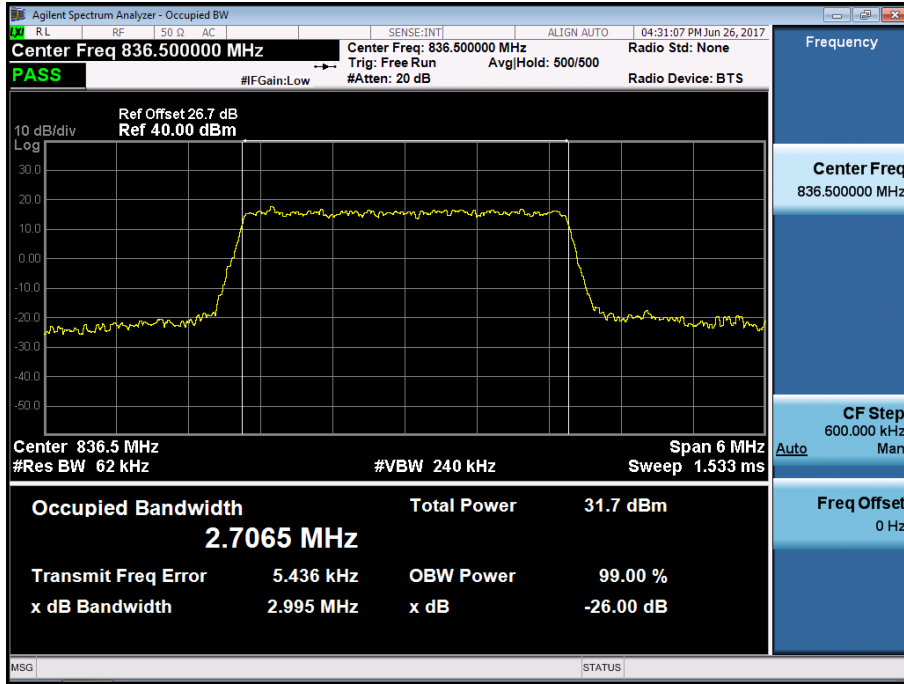

BAND 5. Occupied Bandwidth Plot (3M BW Ch.20525 16QAM\_RB15\_0)

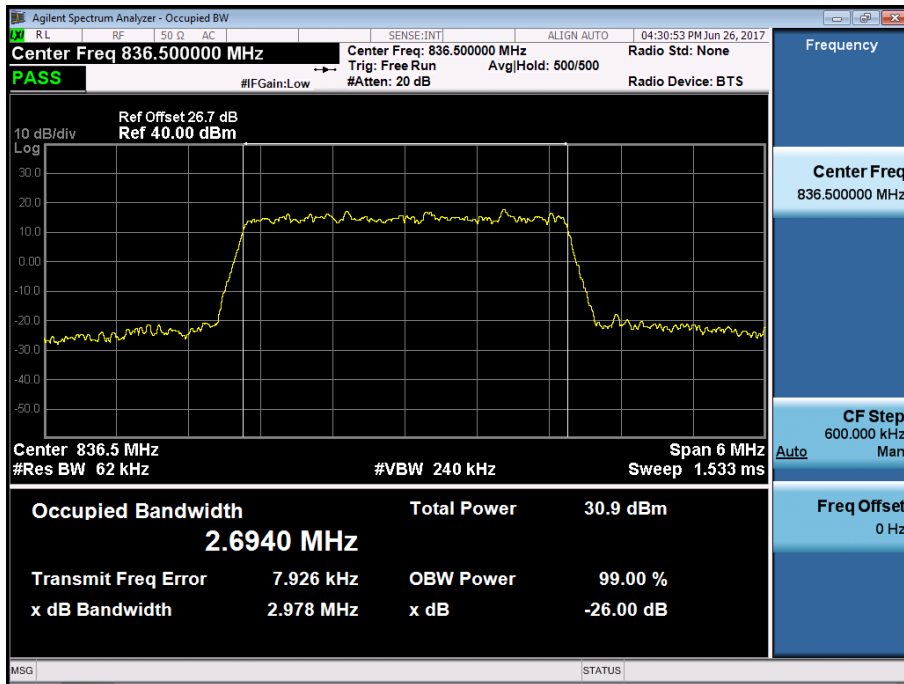

BAND 5. Occupied Bandwidth Plot (5M BW Ch.20525 QPSK\_RB25\_0)

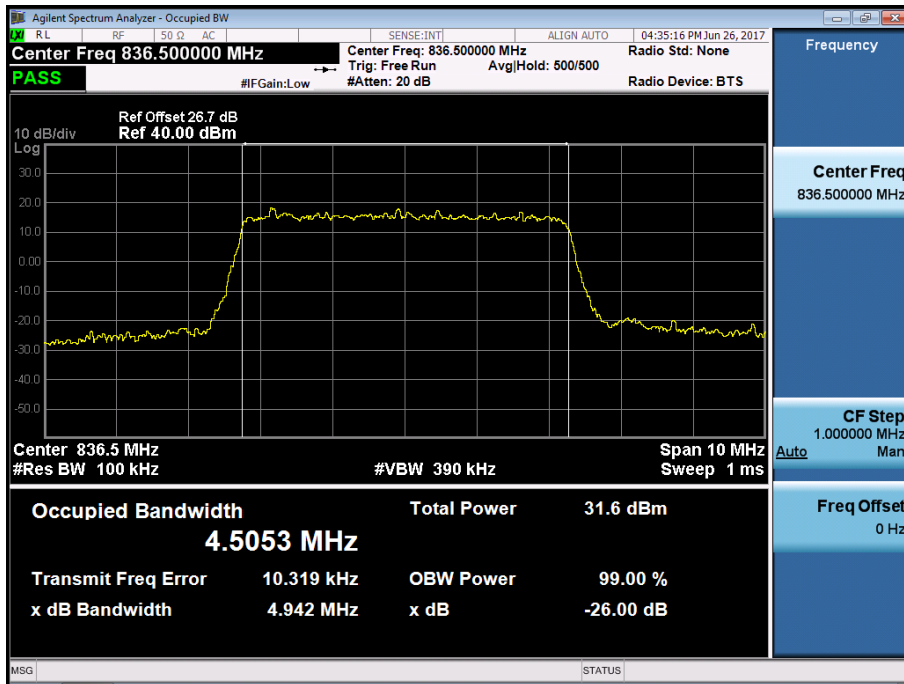

BAND 5. Occupied Bandwidth Plot (5M BW Ch.20525 16QAM\_RB25\_0)

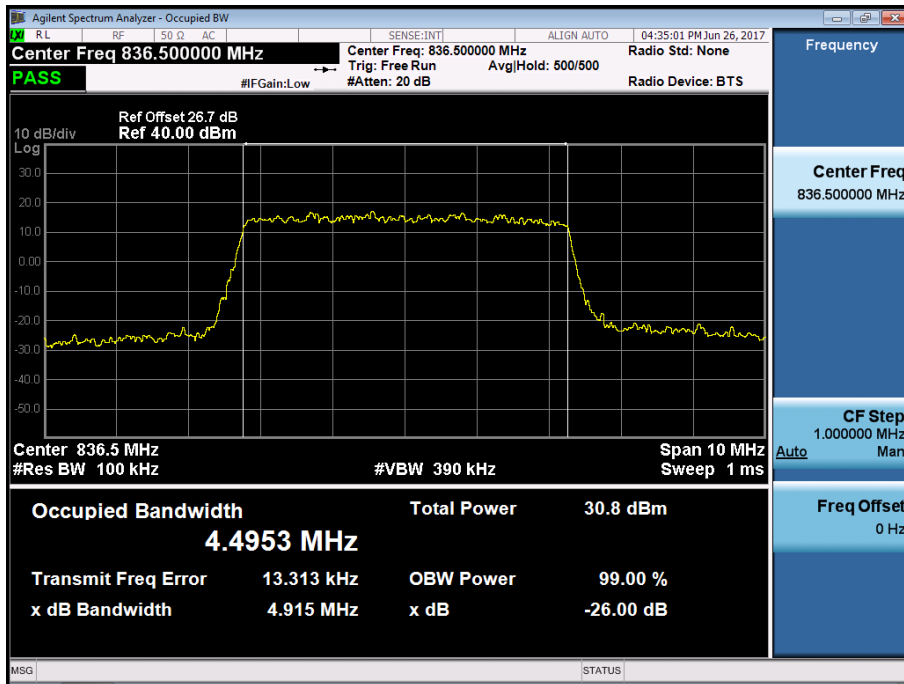

BAND 5. Occupied Bandwidth Plot (10M BW Ch.20525 QPSK\_RB50\_0)

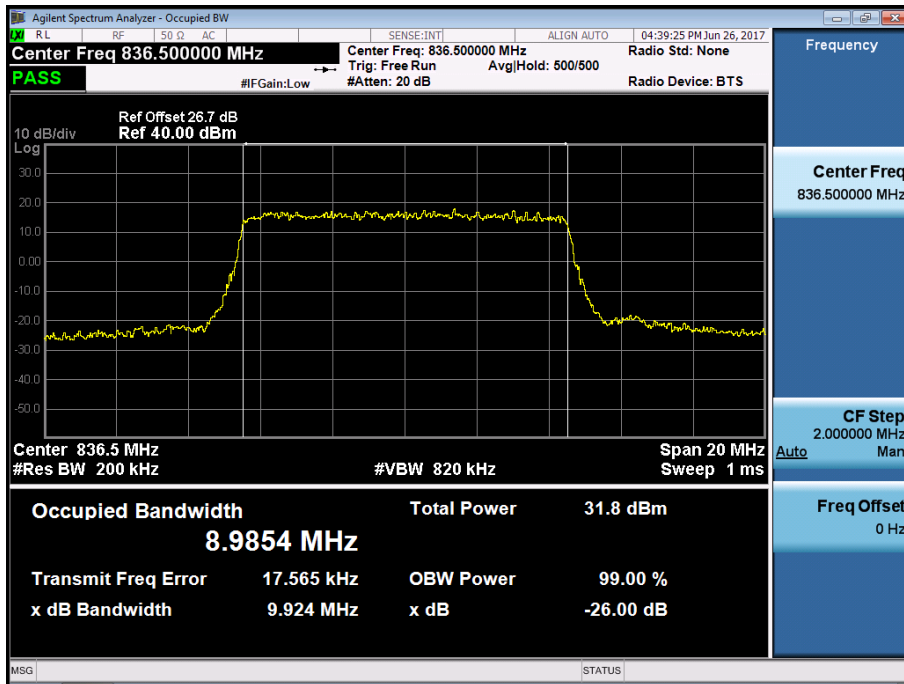

BAND 5. Occupied Bandwidth Plot (10M BW Ch.20525 16QAM\_RB50\_0)

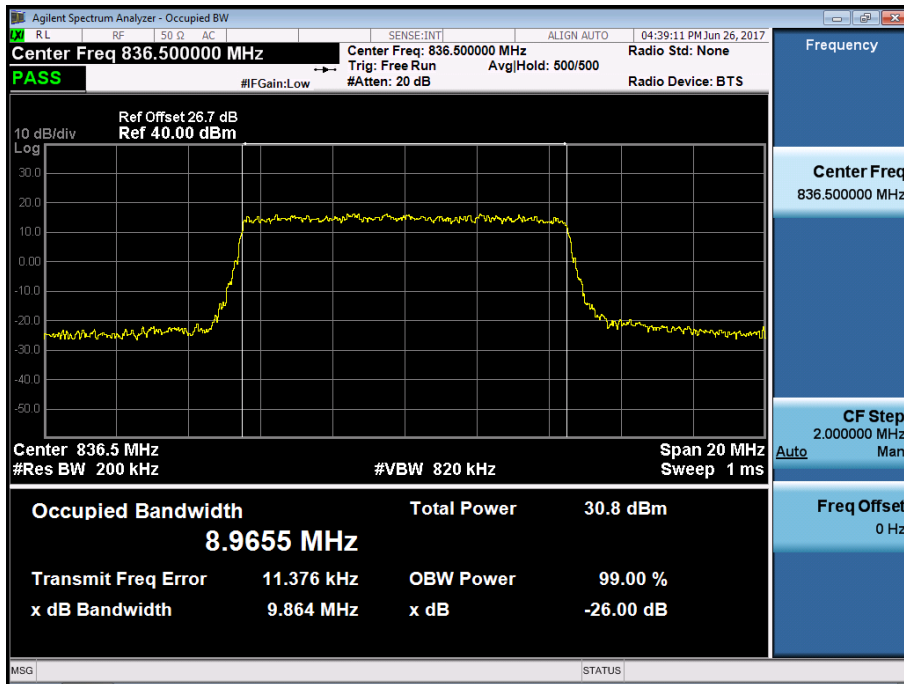

BAND 5. Lower Band Edge Plot (1.4M BW Ch.20407 QPSK\_RB1\_Offset 0)

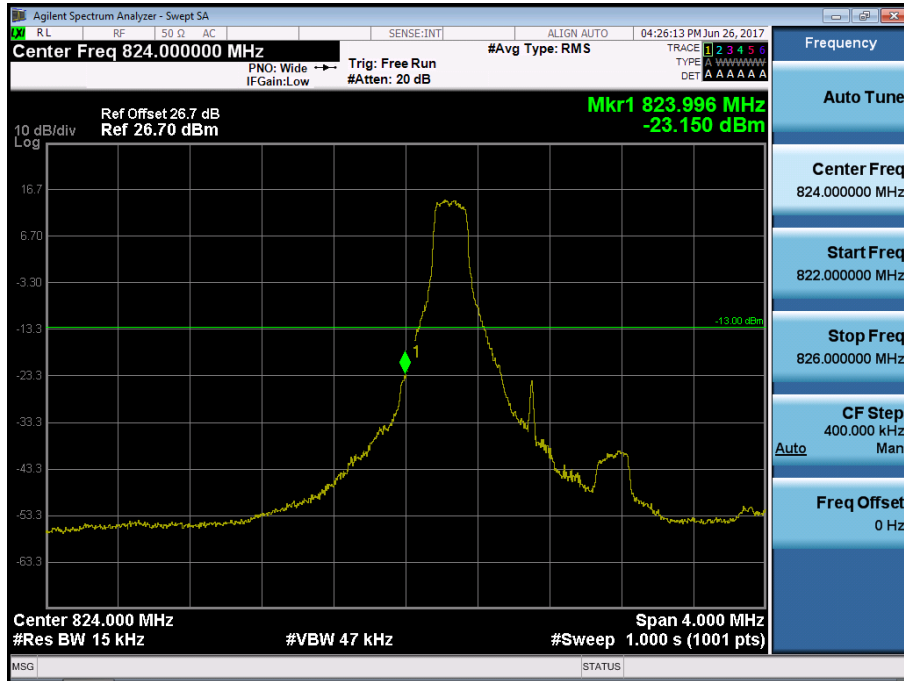

BAND 5. Lower Band Edge Plot (1.4M BW Ch.20407 QPSK\_RB6\_Offset 0)

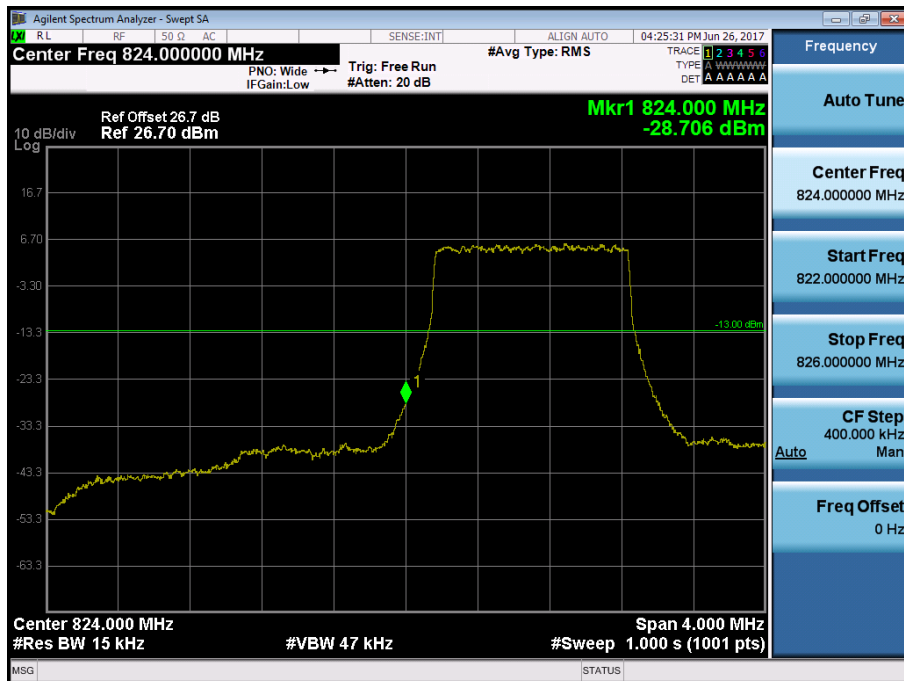



BAND 5. Lower Extended Band Edge Plot (1.4M BW Ch.20407 QPSK\_RB6\_0)



BAND 5. Lower Band Edge Plot (3M BW Ch.20415 QPSK\_RB1\_Offset 0)

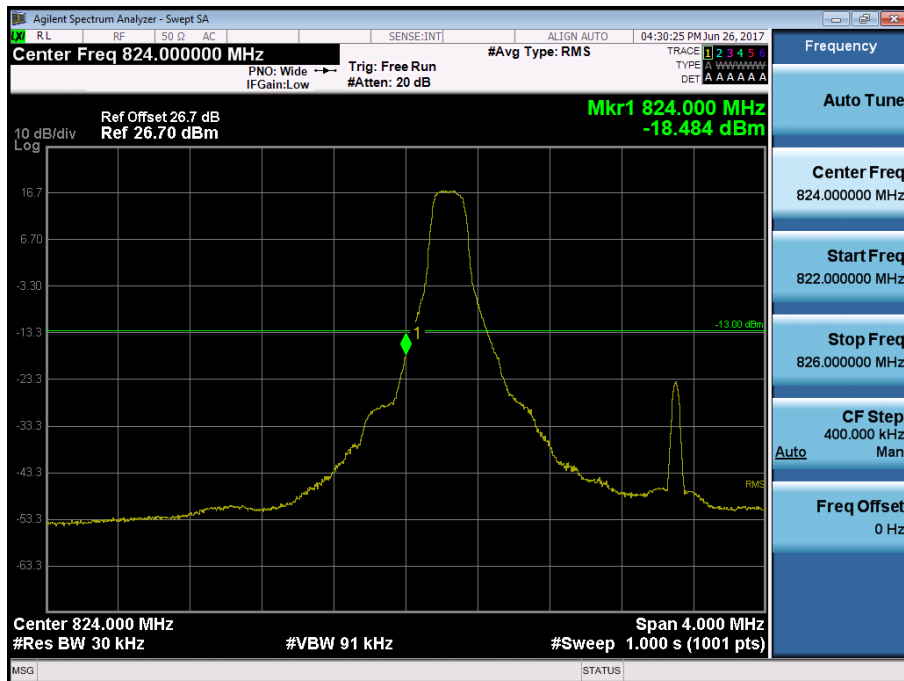

BAND 5. Lower Band Edge Plot (3M BW Ch.20415 QPSK\_RB15\_Offset 0)

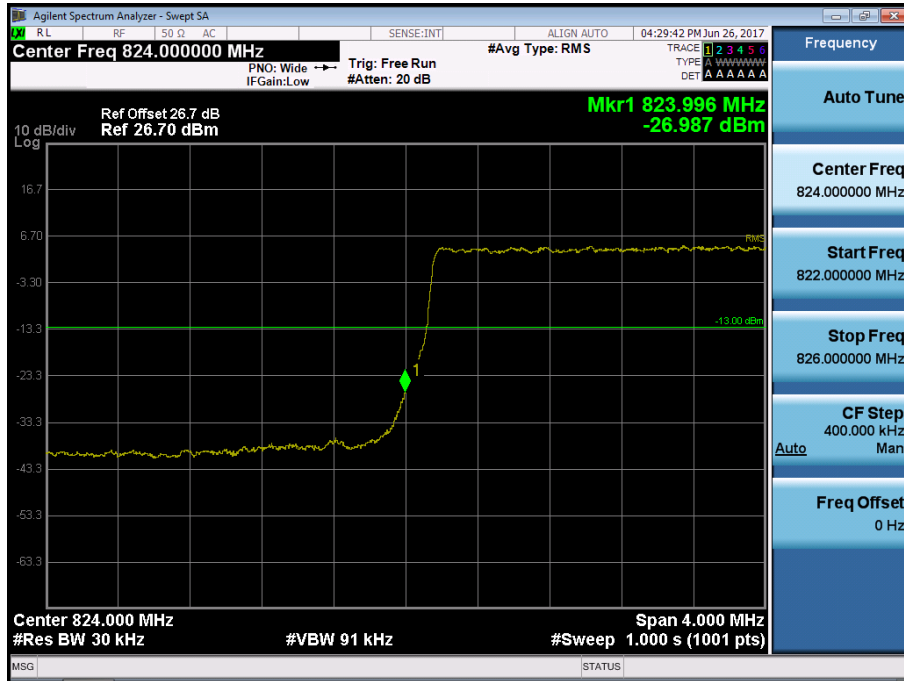

BAND 5. Lower Extended Band Edge Plot (3M BW Ch.20415 QPSK\_RB15\_0)

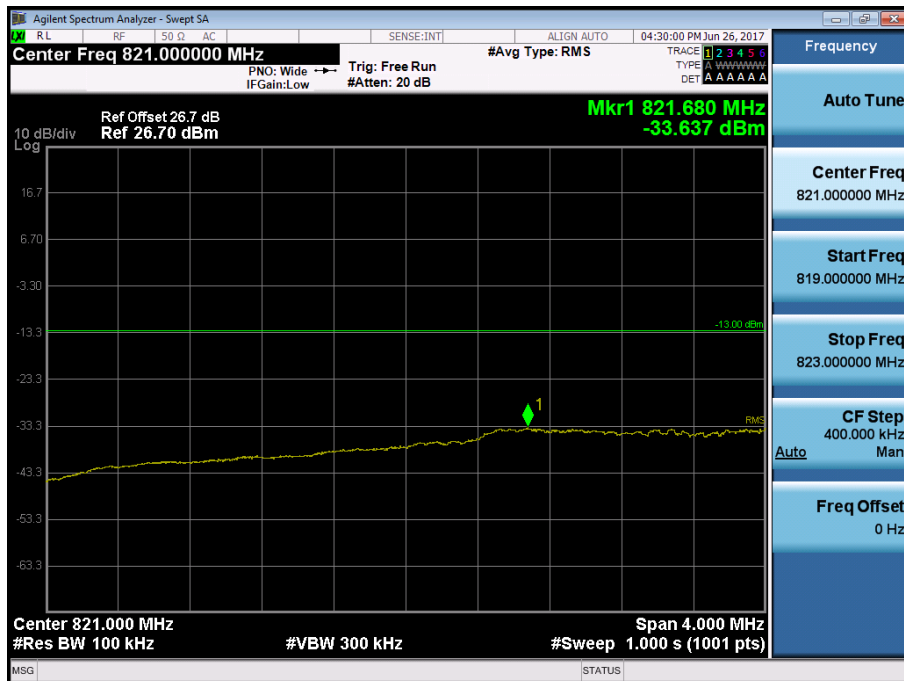

BAND 5. Lower Band Edge Plot (5M BW Ch.20425 QPSK\_RB1\_Offset 0)

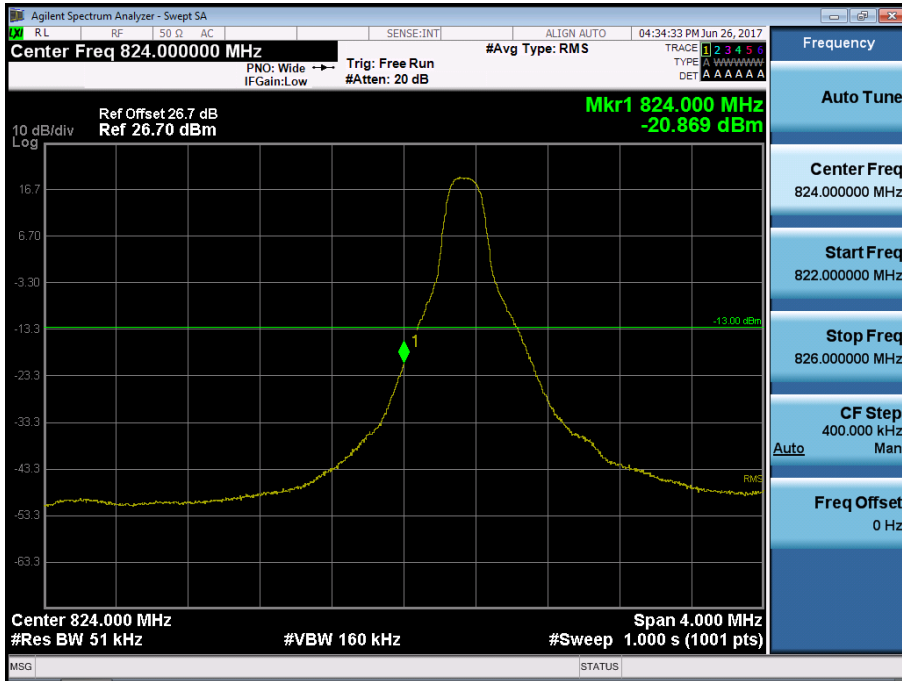

BAND 5. Lower Band Edge Plot (5M BW Ch.20425 QPSK\_RB25\_Offset 0)

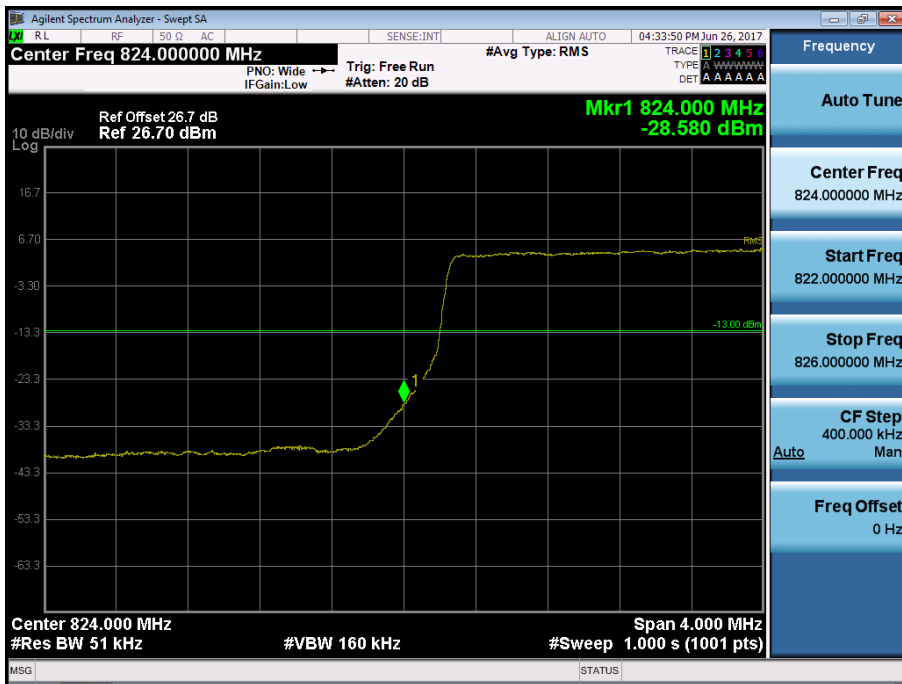

BAND 5. Lower Extended Band Edge Plot (5M BW Ch.20425 QPSK\_RB25\_0)

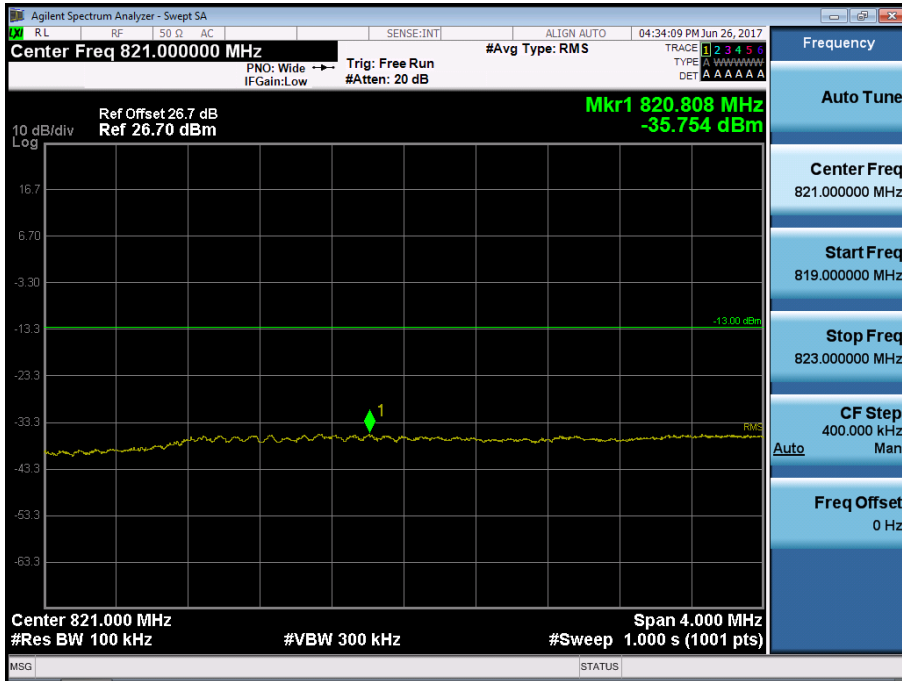

BAND 5. Lower Band Edge Plot (10M BW Ch.20450 QPSK\_RB1\_Offset 0)

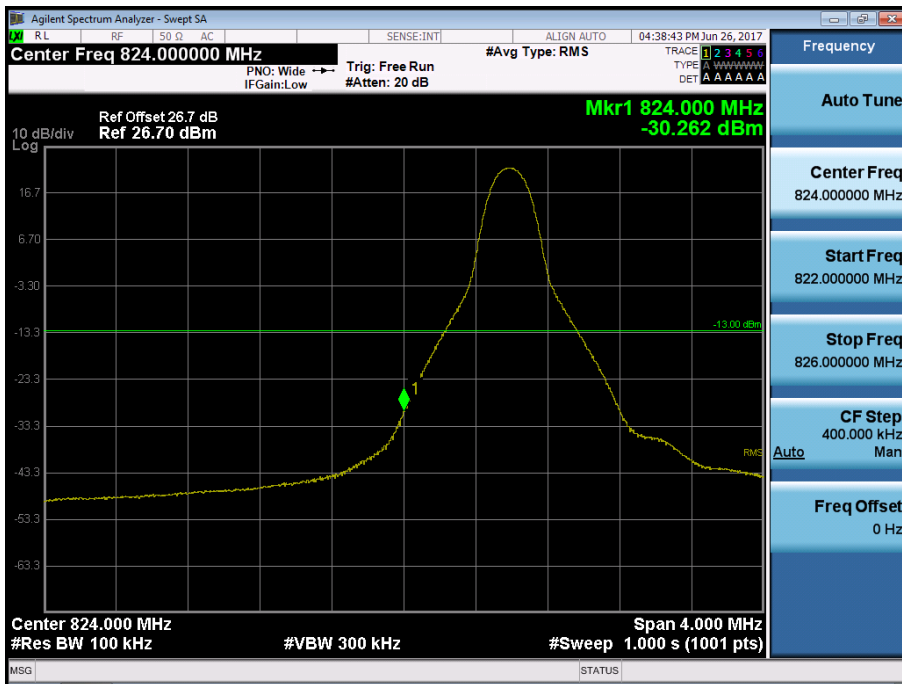

BAND 5. Lower Band Edge Plot (10M BW Ch.20450 QPSK\_RB50\_Offset 0)

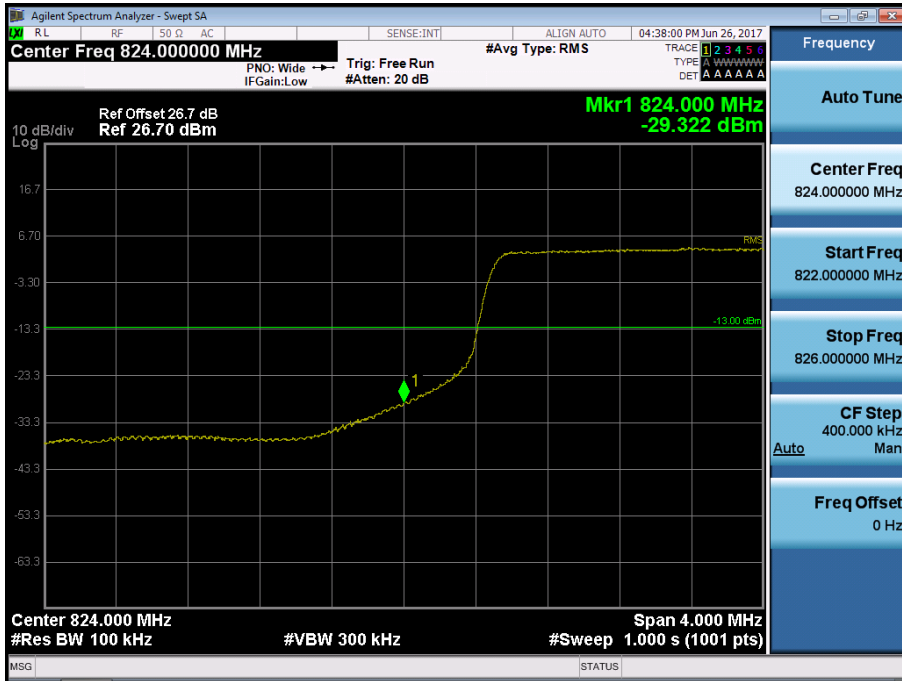

BAND 5. Lower Extended Band Edge Plot (10M BW Ch.20450 QPSK\_RB50\_0)



BAND 5. Upper Band Edge Plot (1.4M BW Ch.20643 QPSK\_RB1\_Offset 5)

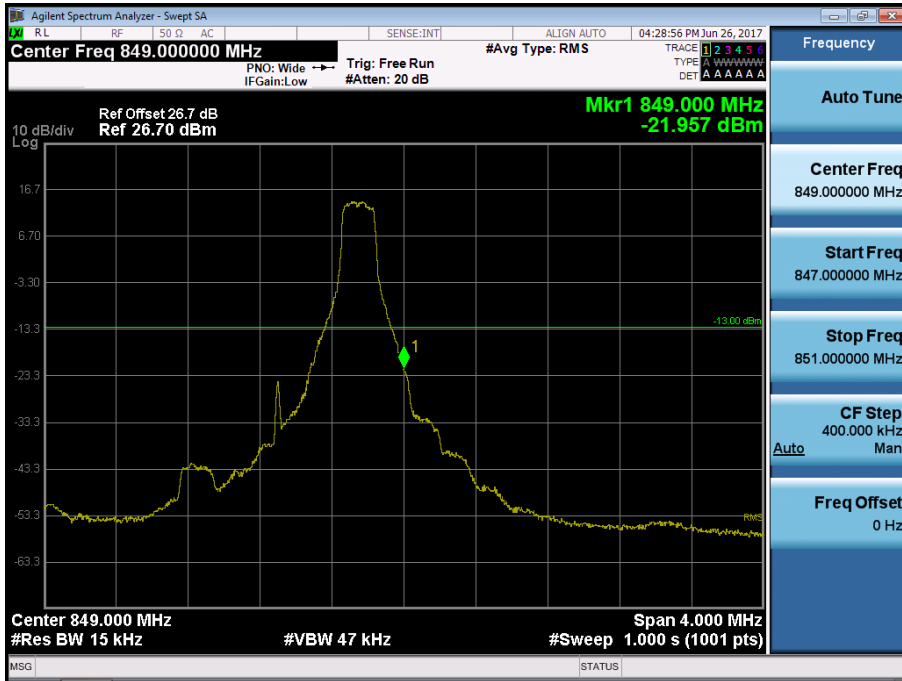

BAND 5. Upper Band Edge Plot (1.4M BW Ch.20643 QPSK\_RB6\_Offset 0)



BAND 5. Upper Extended Band Edge Plot (1.4M BW Ch.20643 QPSK\_RB6\_0)

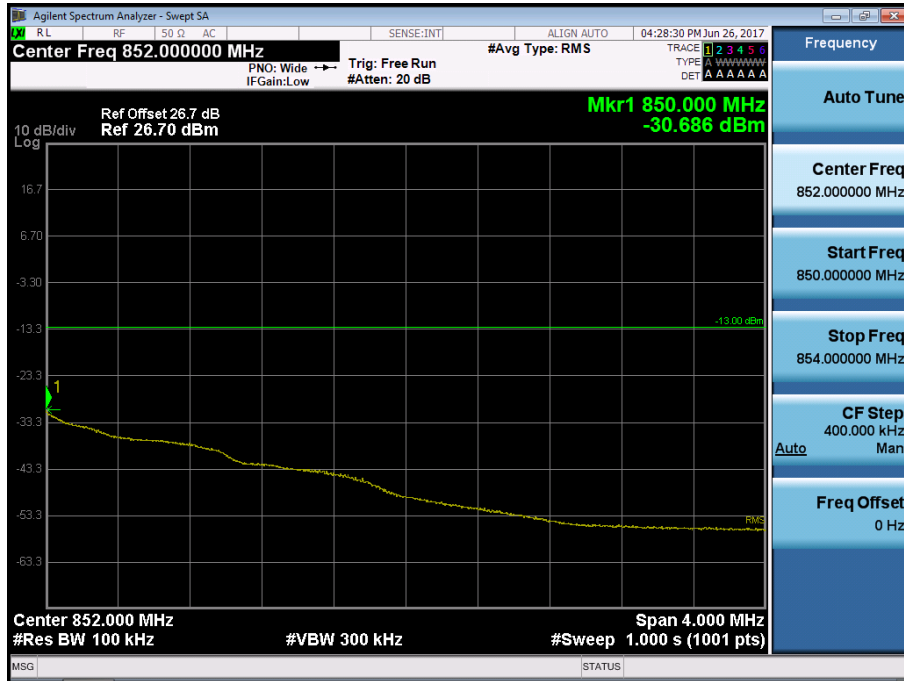

BAND 5. Upper Band Edge Plot (3M BW Ch.20635 QPSK\_RB1\_Offset 14)

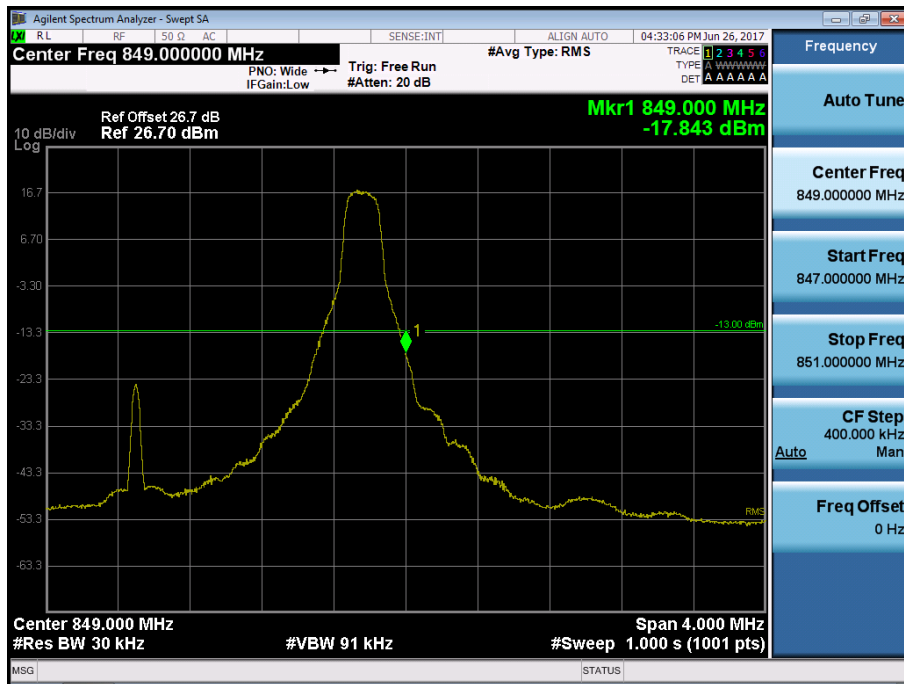

BAND 5. Upper Band Edge Plot (3M BW Ch.20635 QPSK\_RB15\_Offset 0)

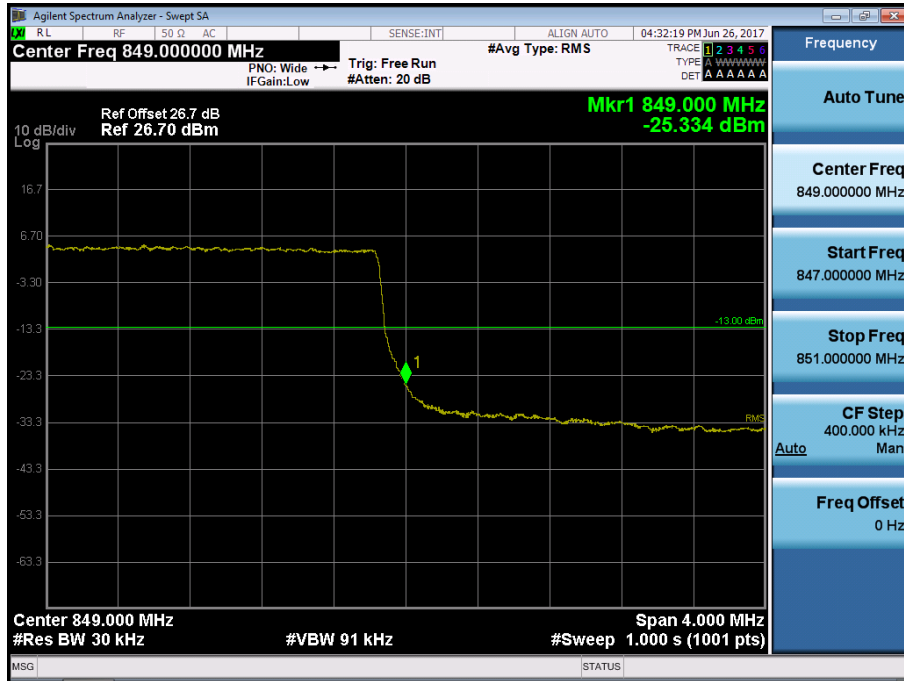

BAND 5. Upper Extended Band Edge Plot (3M BW Ch.20635 QPSK\_RB15\_0)





BAND 5. Upper Band Edge Plot (5M BW Ch.20625 QPSK\_RB1\_Offset 24)

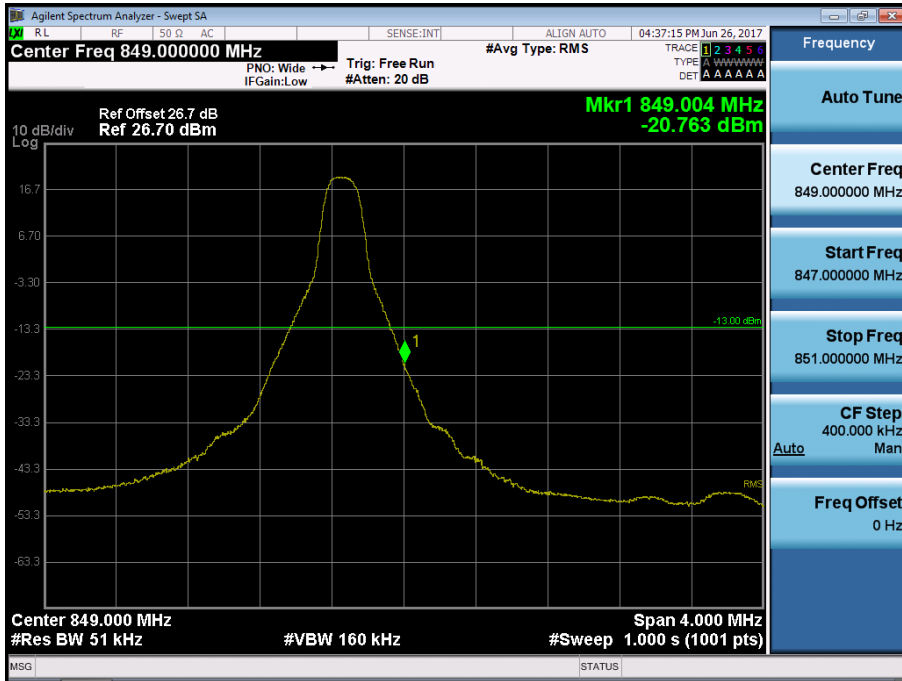

BAND 5. Upper Band Edge Plot (5M BW Ch.20625 QPSK\_RB25\_Offset 0)



BAND 5. Upper Extended Band Edge Plot (5M BW Ch.20625 QPSK\_RB25\_0)

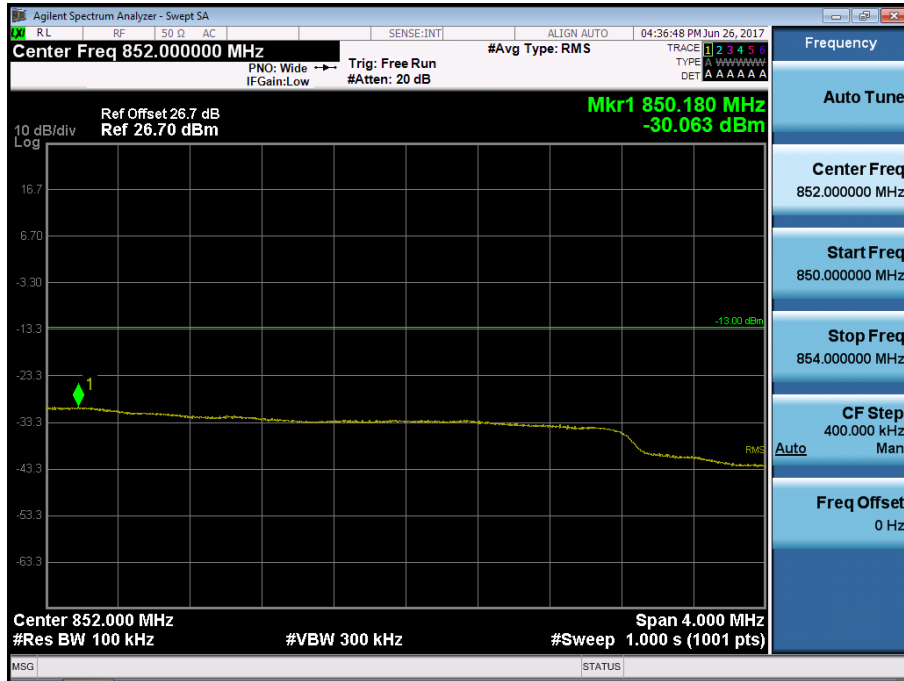

BAND 5. Upper Band Edge Plot (10M BW Ch.20600 QPSK\_RB1\_Offset 49)

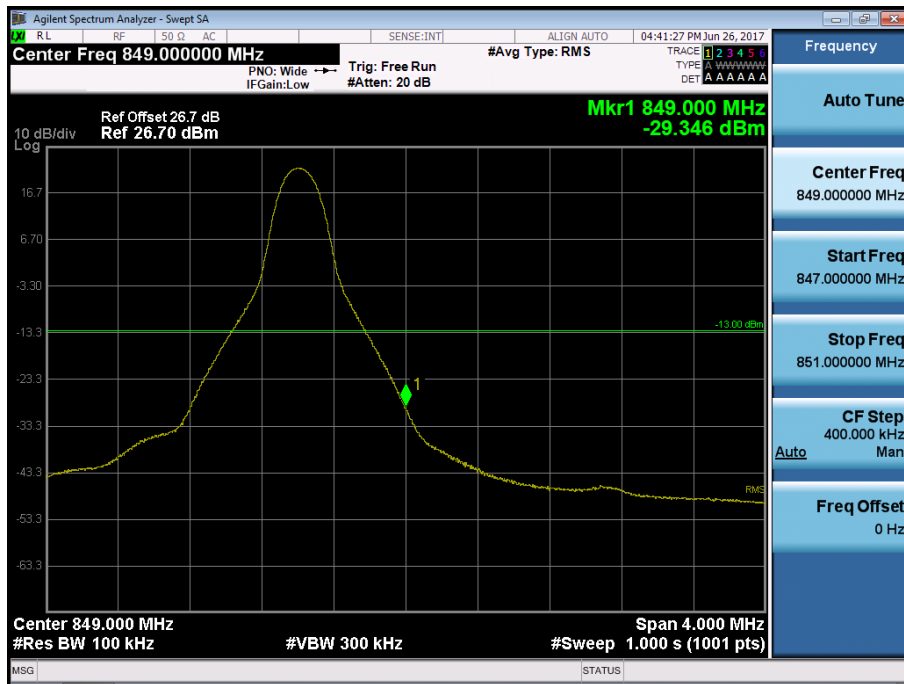

BAND 5. Upper Band Edge Plot (10M BW Ch.20600 QPSK\_RB50\_Offset 0)



BAND 5. Upper Extended Band Edge Plot (10M BW Ch.20600 QPSK\_RB50\_0)



BAND 5. Conducted Spurious Plot (20407ch\_1.4MHz\_QPSK\_RB 1\_0)

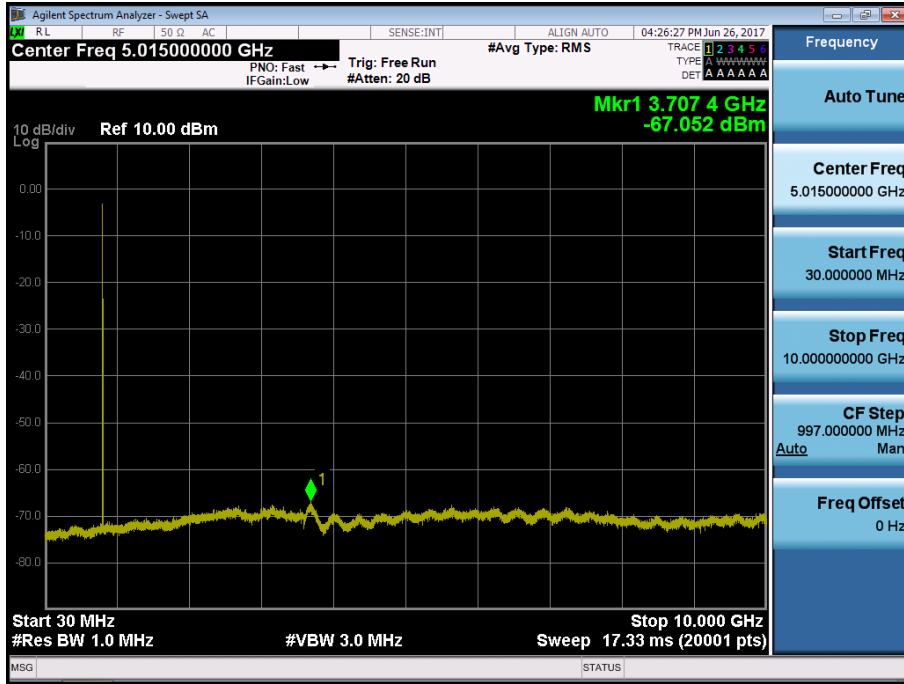

BAND 5. Conducted Spurious Plot (20525ch\_1.4MHz\_QPSK\_RB 1\_0)

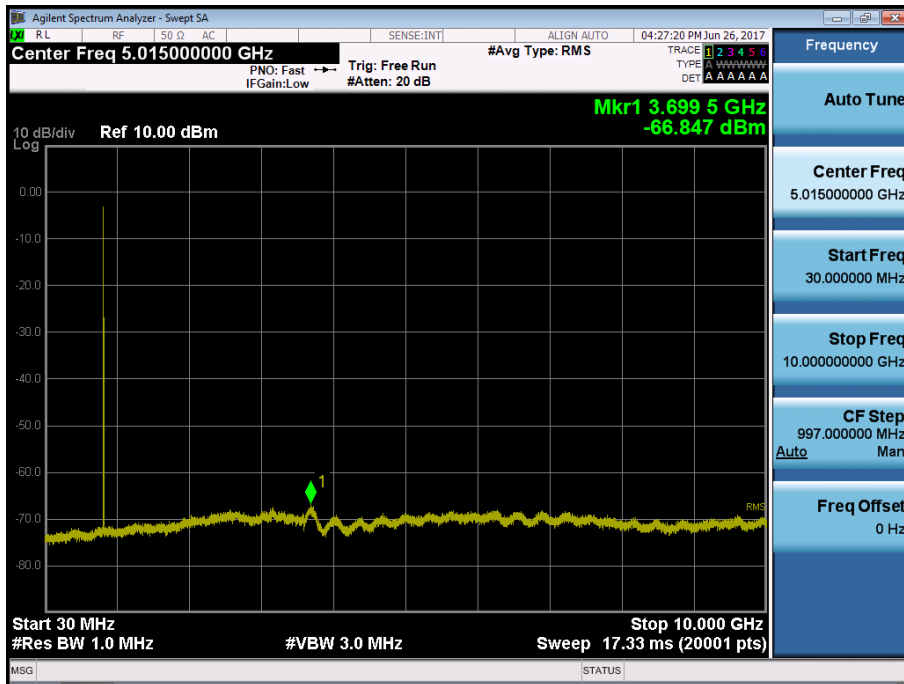

BAND 5. Conducted Spurious Plot (20643ch\_1.4MHz\_QPSK\_RB 1\_0)

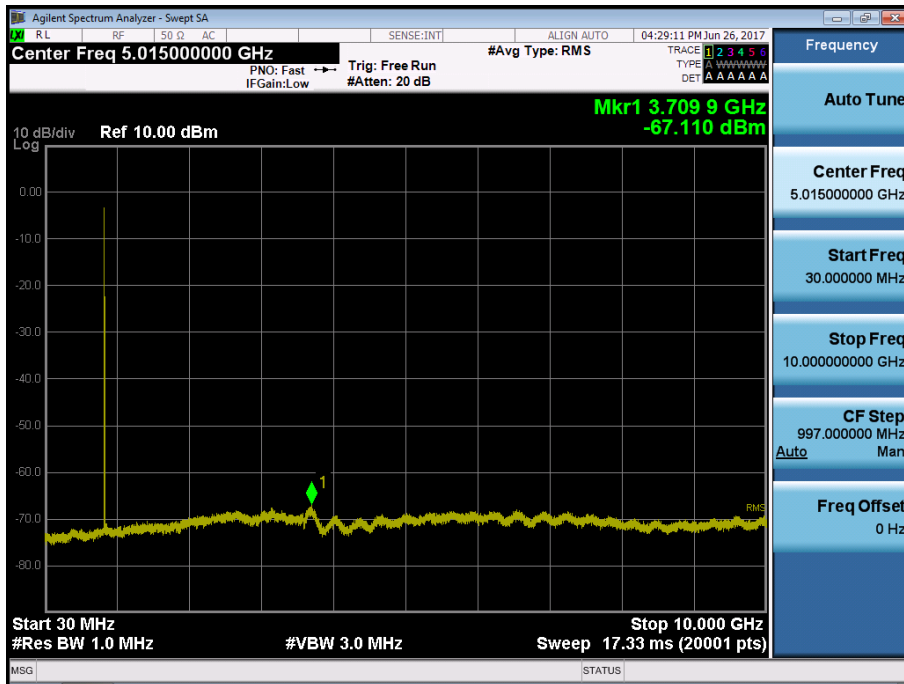

BAND 5. Conducted Spurious Plot (20415ch\_3MHz\_QPSK\_RB 1\_0)

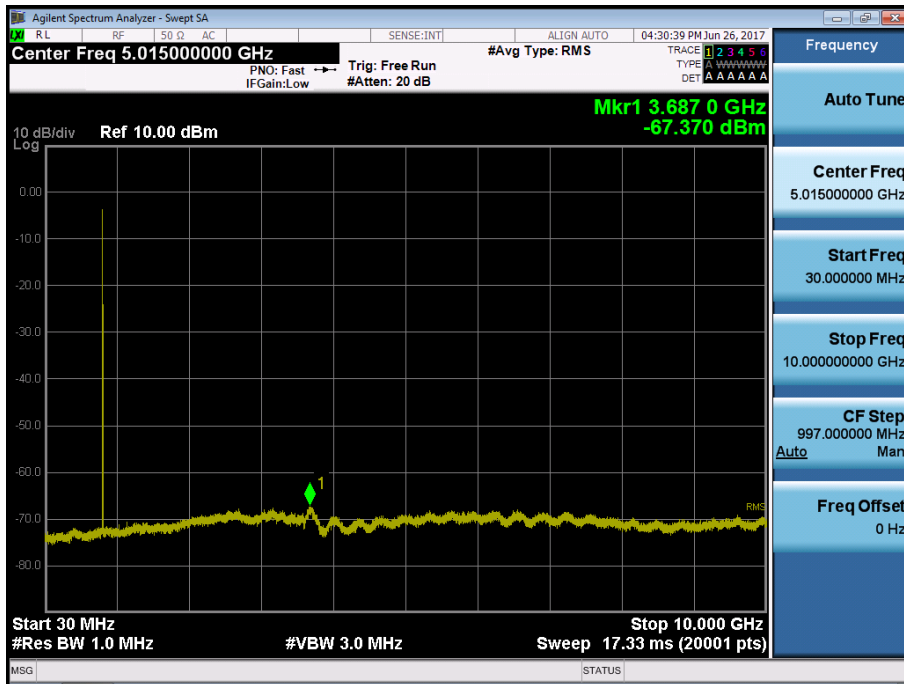

BAND 5. Conducted Spurious Plot (20525ch\_3MHz\_QPSK\_RB 1\_0)

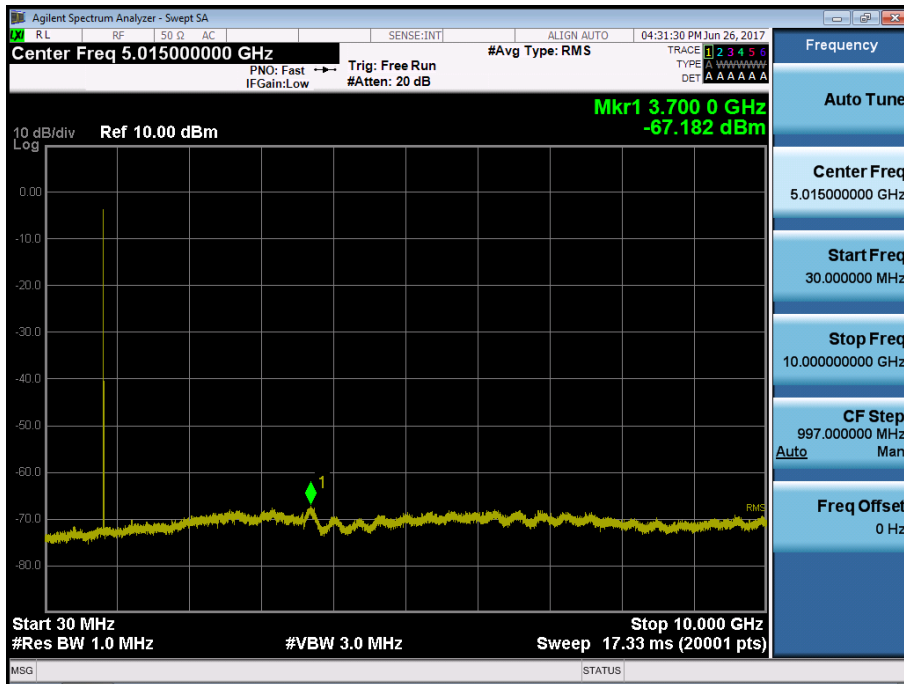

BAND 5. Conducted Spurious Plot (20635ch\_3MHz\_QPSK\_RB 1\_0)

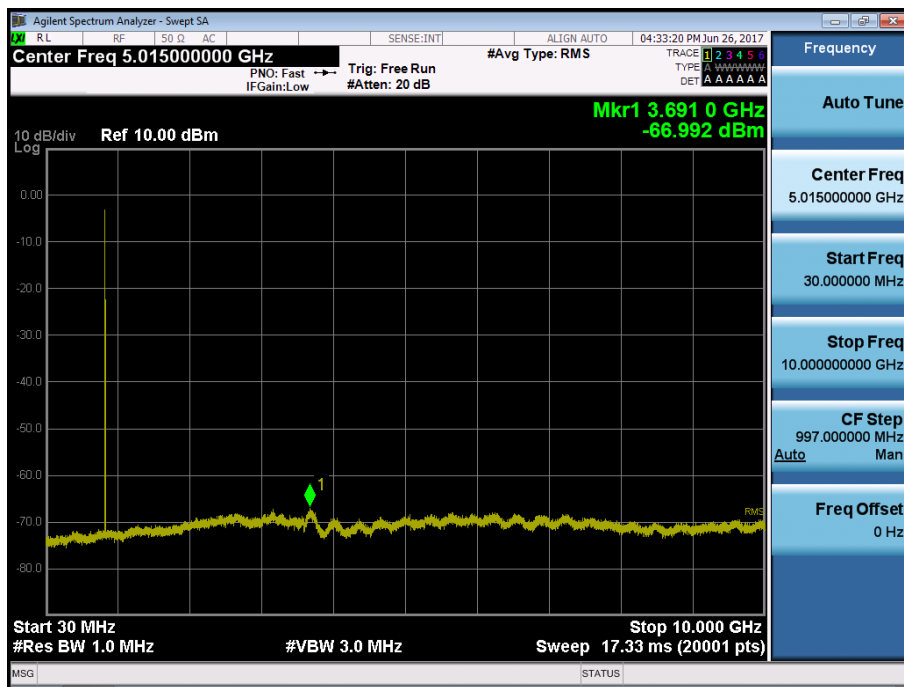

BAND 5. Conducted Spurious Plot (20425ch\_5MHz\_QPSK\_RB 1\_0)

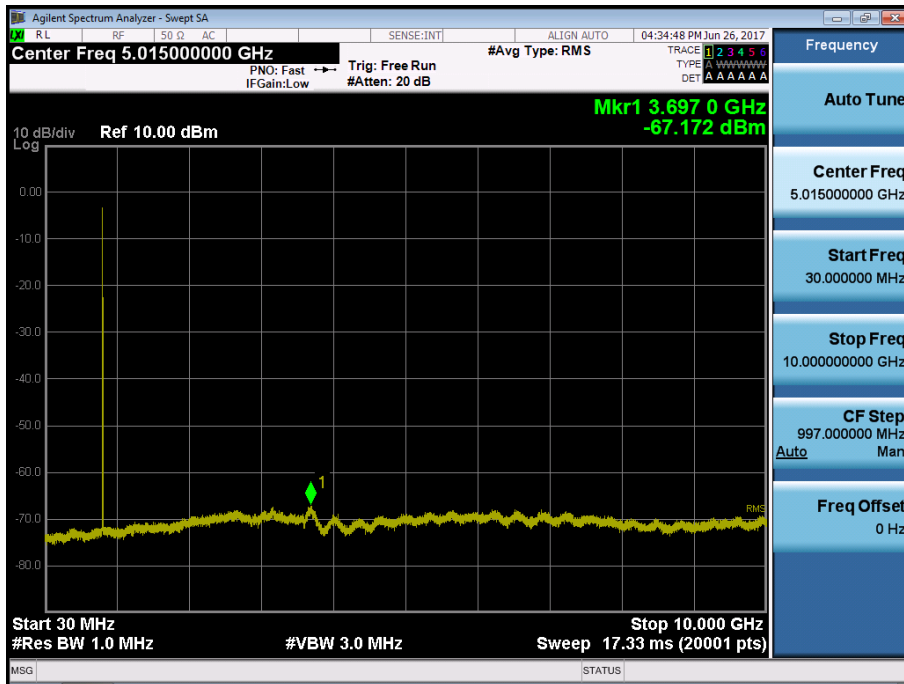

BAND 5. Conducted Spurious Plot (20525ch\_5MHz\_QPSK\_RB 1\_0)

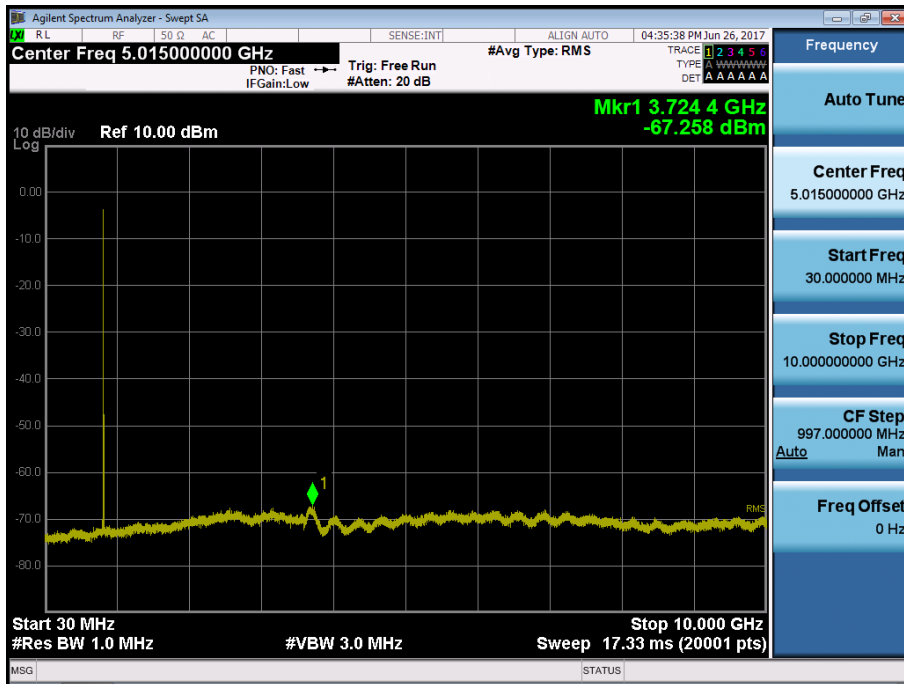

BAND 5. Conducted Spurious Plot (20625ch\_5MHz\_QPSK\_RB 1\_0)

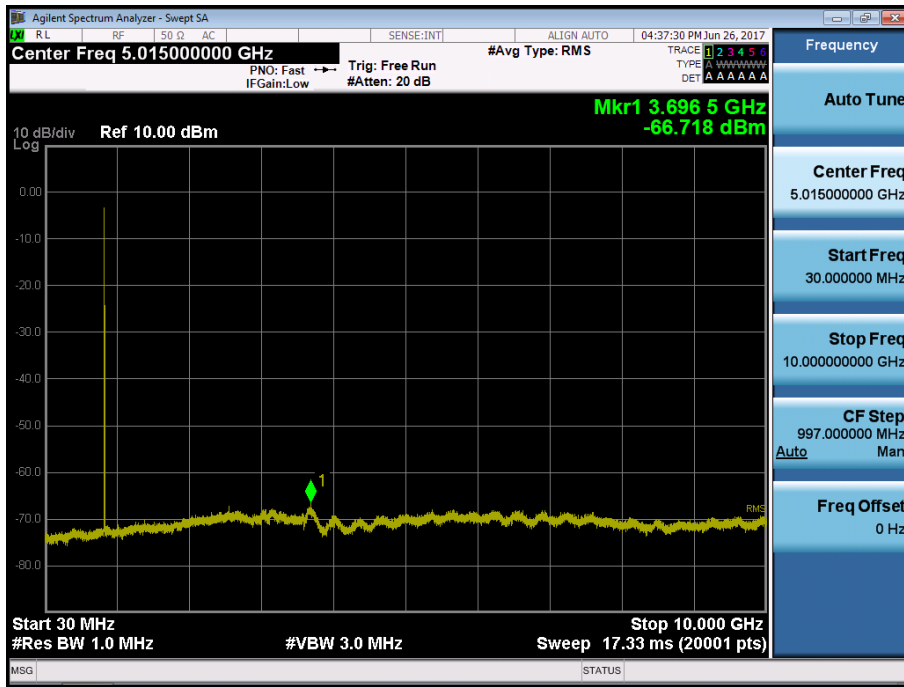

BAND 5. Conducted Spurious Plot (20450ch\_10MHz\_QPSK\_RB 1\_0)

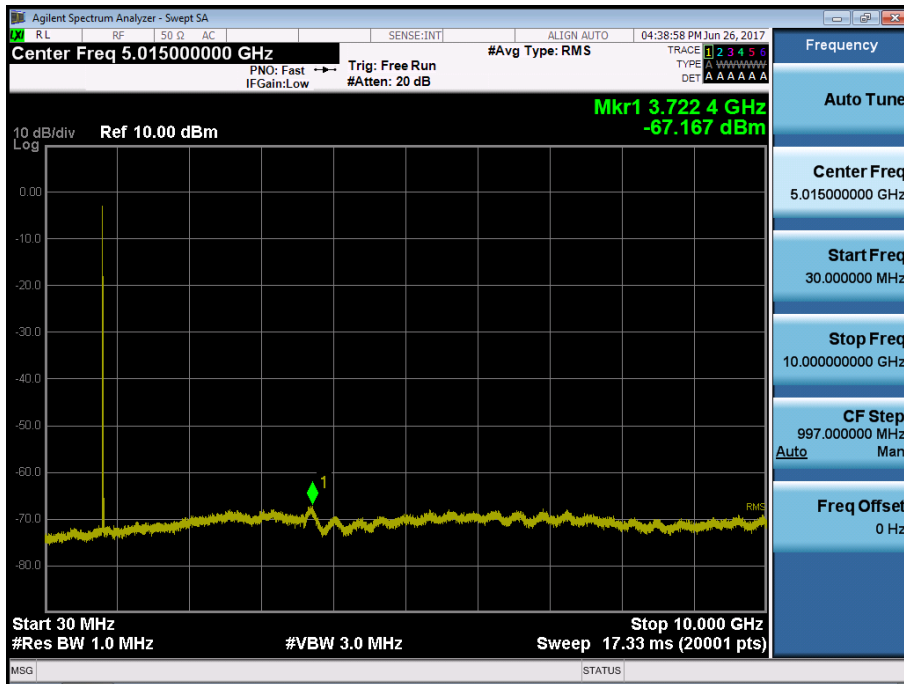



BAND 5. Conducted Spurious Plot (20525ch\_10MHz\_QPSK\_RB 1\_0)

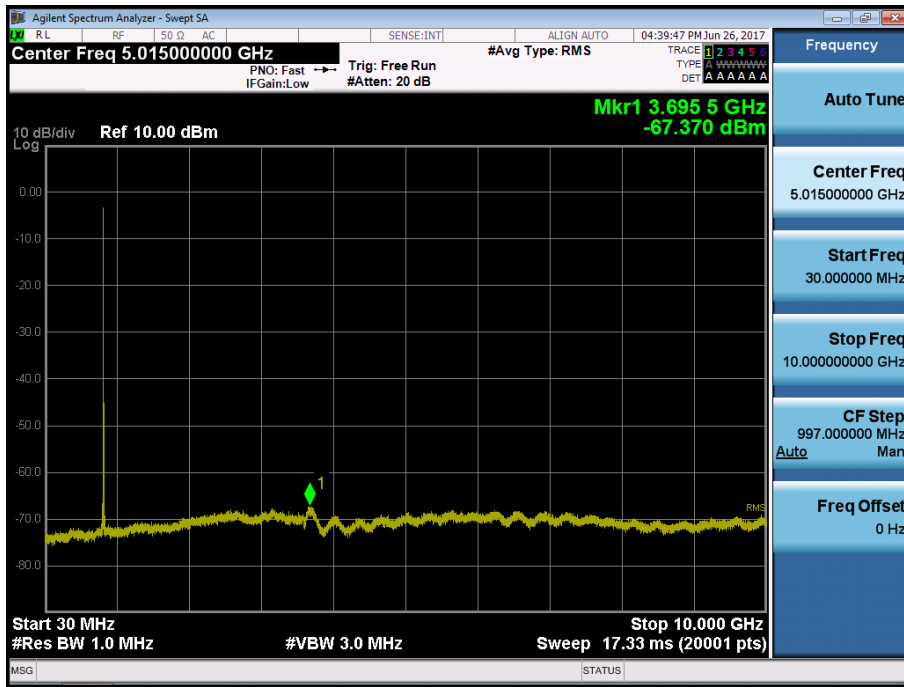

BAND 5. Conducted Spurious Plot (20600ch\_10MHz\_QPSK\_RB 1\_0)

