

# FCC LTE REPORT

## FCC Certification

**Applicant Name:**  
 LG Electronics MobileComm U.S.A., Inc.

**Date of Issue:**  
 June 07, 2017

**Address:**  
 1000 Sylvan Avenue, Englewood Cliffs NJ 07632

**Location:**  
 HCT CO., LTD.,  
 74, Seoicheon-ro 578beon-gil, Majang-myeon,  
 Icheon-si, Gyeonggi-do, 17383, Rep. of KOREA

**Report No.:** HCT-R-1705-F025-1  
**HCT FRN:** 0005866421

**FCC ID:** ZNFM700H

**APPLICANT:** LG Electronics MobileComm U.S.A., Inc.

**FCC Model(s):** LG-M700H  
**Additional FCC Model(s):** LGM700H, M700H  
**EUT Type:** GSM/WCDMA/LTE Phone with Bluetooth4.2LE, WIFI802.11 b/g/n  
**FCC Classification:** Licensed Portable Transmitter Held to Ear (PCE)  
**FCC Rule Part(s):** §27, §2

Mode (MHz)	Tx Frequency (MHz)	Emission Designator	Modulation	EIRP	
				Max. Power (W)	Max. Power (dBm)
LTE – Band66 (1.4)	1710.7 – 1779.3	1M10G7D	QPSK	0.081	19.08
		1M10W7D	16QAM	0.063	18.01
LTE – Band66 (3)	1711.5 – 1778.5	2M70G7D	QPSK	0.081	19.10
		2M70W7D	16QAM	0.067	18.23
LTE – Band66 (5)	1712.5 – 1777.5	4M50G7D	QPSK	0.081	19.07
		4M50W7D	16QAM	0.062	17.94
LTE – Band66 (10)	1715.0 – 1775.0	8M99G7D	QPSK	0.076	18.81
		8M94W7D	16QAM	0.061	17.82
LTE – Band66 (15)	1717.5 – 1772.5	13M4G7D	QPSK	0.081	19.06
		13M4W7D	16QAM	0.063	17.96
LTE – Band66 (20)	1720.0 – 1770.0	17M9G7D	QPSK	0.084	19.22
		17M9W7D	16QAM	0.065	18.13

Mode (MHz)	Tx Frequency (MHz)	Emission Designator	Modulation	ERP	
				Max. Power (W)	Max. Power (dBm)
LTE – Band13 (5)	779.5 –784.5	4M51G7D	QPSK	0.030	14.78
		4M49W7D	16QAM	0.023	13.64
LTE – Band13 (10)	782.0	8M97G7D	QPSK	0.032	15.10
		8M95W7D	16QAM	0.024	13.88

The measurements shown in this report were made in accordance with the procedures specified in CFR47 section §2.947. I assume full responsibility for the accuracy and completeness of these measurements, and for the qualifications of all persons taking them.

HCT CO., LTD. Certifies that no party to this application has subject to a denial of Federal benefits that includes FCC benefits pursuant to section 5301 of the Anti-Drug Abuse Act of 1998, 21 U.S. C.853(a)



**Report prepared by : Jeong Ho Kim**  
**Engineer of Telecommunication Testing Center**



**Report approved by : Jong Seok Lee**  
**Manager of Telecommunication Testing Center**

This report only responds to the tested sample and may not be reproduced, except in full, without written approval of the HCT Co., Ltd.

## Version

TEST REPORT NO.	DATE	DESCRIPTION
HCT-R-1705-F025	May 29, 2017	- First Approval Report
HCT-R-1705-F025-1	June 07, 2017	- Removed the LTE Band 4 on the report. - Revised the conducted spurious emission results (LTE Band 66) - Equipment List revised Page on 16.

---

# Table of Contents

1. GENERAL INFORMATION .....	6
2. INTRODUCTION .....	8
2.1. EUT DESCRIPTION.....	8
2.2. MEASURING INSTRUMENT CALIBRATION.....	8
2.3. TEST FACILITY .....	8
3. DESCRIPTION OF TESTS.....	9
3.1 ERP/EIRP RADIATED POWER AND RADIATED SPURIOUS EMISSIONS.....	9
3.2 AWS – MOBILE FREQUENCY BLOCKS (1710 – 1780 MHz).....	10
3.3 BLOCK B FREQUENCY RANGE (775 – 788 MHz) .....	10
3.4 PEAK-AVERAGE RATIO. ....	11
3.5 OCCUPIED BANDWIDTH. ....	13
3.6 SPURIOUS AND HARMONIC EMISSIONS AT ANTENNA TERMINAL.....	14
3.7 FREQUENCY STABILITY / VARIATION OF AMBIENT TEMPERATURE .....	15
4. LIST OF TEST EQUIPMENT .....	16
5. MEASUREMENT UNCERTAINTY .....	17
6. SUMMARY OF TEST RESULTS .....	18
7. SAMPLE CALCULATION.....	19
8. TEST DATA .....	20
8.1 EQUIVALENT ISOTROPIC RADIATED POWER (Band 66) .....	20
8.2 EFFECTIVE RADIATED POWER (Band 13).....	24
8.3 RADIATED SPURIOUS EMISSIONS.....	25
8.3.1 RADIATED SPURIOUS EMISSIONS (1.4 MHz Band 66 LTE) .....	25
8.3.2 RADIATED SPURIOUS EMISSIONS (3 MHz Band 66 LTE) .....	26
8.3.3 RADIATED SPURIOUS EMISSIONS (5 MHz Band 66 LTE) .....	27
8.3.4 RADIATED SPURIOUS EMISSIONS (10 MHz Band 66 LTE) .....	28
8.3.5 RADIATED SPURIOUS EMISSIONS (15 MHz Band 66 LTE) .....	29
8.3.6 RADIATED SPURIOUS EMISSIONS (20 MHz Band 66 LTE) .....	30
8.3.7 RADIATED SPURIOUS EMISSIONS (5 MHz Band 13 LTE).....	31
8.3.8 RADIATED SPURIOUS EMISSIONS (10 MHz Band 13 LTE).....	32
8.3.8.1 RADIATED SPURIOUS EMISSIONS (1559 ~ 1610 MHz Band) .....	33
8.3.8.2 RADIATED SPURIOUS EMISSIONS (1559 ~ 1610 MHz Band) .....	33
8.4 PEAK-TO-AVERAGE RATIO .....	34
8.5 OCCUPIED BANDWIDTH .....	35
8.6 CONDUCTED SPURIOUS EMISSIONS .....	36
8.6.1 BAND EDGE.....	37

<b>8.7 FREQUENCY STABILITY / VARIATION OF AMBIENT TEMPERATURE .....</b>	<b>38</b>
<b>8.7.1 FREQUENCY STABILITY (1.4 MHz Band 66 LTE) .....</b>	<b>38</b>
<b>8.7.2 FREQUENCY STABILITY (3 MHz Band 66 LTE) .....</b>	<b>39</b>
<b>8.7.3 FREQUENCY STABILITY (5 MHz Band 66 LTE) .....</b>	<b>40</b>
<b>8.7.4 FREQUENCY STABILITY (10 MHz Band 66 LTE) .....</b>	<b>41</b>
<b>8.7.5 FREQUENCY STABILITY (15 MHz Band 66 LTE) .....</b>	<b>42</b>
<b>8.7.6 FREQUENCY STABILITY (20 MHz Band 66 LTE) .....</b>	<b>43</b>
<b>8.7.7 FREQUENCY STABILITY (5 MHz Band 13 LTE) .....</b>	<b>44</b>
<b>8.7.8 FREQUENCY STABILITY (10 MHz Band 13 LTE) .....</b>	<b>45</b>
<b>9. TEST PLOTS.....</b>	<b>46</b>

# MEASUREMENT REPORT

## 1. GENERAL INFORMATION

**Applicant Name:** LG Electronics MobileComm U.S.A., Inc.

**Address:** 1000 Sylvan Avenue, Englewood Cliffs NJ 07632

**FCC ID:** ZNFM700H

**Application Type:** Certification

**FCC Classification:** Licensed Portable Transmitter Held to Ear (PCE)

**FCC Rule Part(s):** §27, §2

**EUT Type:** GSM/WCDMA/LTE Phone with Bluetooth4.2LE, WIFI802.11 b/g/n

**FCC Model(s):** LG-M700H

**Additional FCC Model(s):** LGM700H, M700H

**Tx Frequency :** 1710.7 MHz – 1779.3 MHz (LTE – Band 66 (1.4 MHz))  
1711.5 MHz – 1778.5 MHz (LTE – Band 66 (3 MHz))  
1712.5 MHz – 1777.5 MHz (LTE – Band 66 (5 MHz))  
1715.0 MHz – 1775.0 MHz (LTE – Band 66 (10 MHz))  
1717.5 MHz – 1772.5 MHz (LTE – Band 66 (15 MHz))  
1720.0 MHz – 1770.0 MHz (LTE – Band 66 (20 MHz))

779.5 MHz – 784.5 MHz (LTE – Band 13 (5MHz))  
782 MHz (LTE – Band 13 (10 MHz))

**Max. RF Output Power:**

Band 66 (1.4 MHz):	0.081 W (QPSK) (19.08 dBm) 0.063 W (16-QAM) (18.01 dBm)
Band 66 (3 MHz):	0.081 W (QPSK) (19.10 dBm) 0.067 W (16-QAM) (18.23 dBm)
Band 66 (5 MHz):	0.081 W (QPSK) (19.07 dBm) 0.062 W (16-QAM) (17.94 dBm)
Band 66 (10 MHz):	0.076 W (QPSK) (18.81 dBm) 0.061 W (16-QAM) (17.82 dBm)
Band 66 (15 MHz):	0.081 W (QPSK) (19.06 dBm) 0.063 W (16-QAM) (17.96 dBm)
Band 66 (20 MHz):	0.084 W (QPSK) (19.22 dBm) 0.065 W (16-QAM) (18.13 dBm)
Band 13 (5 MHz) :	0.030 W (QPSK) (14.78 dBm) 0.023 W (16-QAM) (13.64 dBm)
Band 13 (10 MHz) :	0.032 W (QPSK) (15.10 dBm) 0.024 W (16-QAM) (13.88 dBm)

**Emission Designator(s):**

Band 66 (1.4 MHz):	1M10G7D (QPSK) / 1M10W7D (16-QAM)
Band 66 (3 MHz):	2M70G7D (QPSK) / 2M70W7D (16-QAM)
Band 66 (5 MHz):	4M50G7D (QPSK) / 4M50W7D (16-QAM)
Band 66 (10 MHz):	8M99G7D (QPSK) / 8M94W7D (16-QAM)
Band 66 (15 MHz):	13M4G7D (QPSK) / 13M4W7D (16-QAM)
Band 66 (20 MHz):	17M9G7D (QPSK) / 17M9W7D (16-QAM)
Band 13 (5 MHz) :	4M51G7D (QPSK) / 4M49W7D (16-QAM)
Band 13 (10 MHz) :	8M97G7D (QPSK) / 8M95W7D (16-QAM)

**Date(s) of Tests:** April 25, 2017 ~ May 29, 2017

**Antenna Specification:**

Manufacturer:	LS Mtron Co. Ltd.
Antenna type:	PIFA Antenna (Planar Inverted F)

## **2. INTRODUCTION**

### **2.1. EUT DESCRIPTION**

The LG Electronics MobileComm U.S.A., Inc. LG-M700H GSM/WCDMA/LTE Phone with Bluetooth4.2LE, WIFI802.11 b/g/n consists of LTE 13 and LTE 66.

### **2.2. MEASURING INSTRUMENT CALIBRATION**

The measuring equipment, which was utilized in performing the tests documented herein, has been calibrated in accordance with the manufacturer's recommendations for utilizing calibration equipment, which is traceable to recognized national standards.

### **2.3. TEST FACILITY**

The Fully-anechoic chamber and conducted measurement facility used to collect the radiated data are located at the **74, Seoicheon-ro 578beon-gil, Majang-myeon, Icheon-si, Gyeonggi-do, 17383, Rep. of KOREA.**



## **3. DESCRIPTION OF TESTS**

### **3.1 ERP/EIRP RADIATED POWER AND RADIATED SPURIOUS EMISSIONS**

Note: ERP(Effective Radiated Power), EIRP(Effective Isotropic Radiated Power)

Test Procedure

Radiated emission measurements are performed in the Fully-anechoic chamber. The equipment under test is placed on a non-conductive table 3-meters away from the receive antenna in accordance with ANSI/TIA-603-D-2010 Clause 2.2.17. The turntable is rotated through 360 degrees, and the receiving antenna scans in order to determine the level of the maximized emission. The level and position of the maximized emission is recorded with the spectrum analyzer using a RMS detector.

A half wave dipole is then substituted in place of the EUT. For emissions above 1GHz, a horn antenna is substituted in place of the EUT. The substitute antenna is driven by a signal generator and the previously recorded signal was duplicated.

The power is calculated by the following formula;

$$P_{d(\text{dBm})} = P_{g(\text{dBm})} - \text{cable loss (dB)} + \text{antenna gain (dB)}$$

Where:  $P_d$  is the dipole equivalent power and  $P_g$  is the generator output power into the substitution antenna.

The maximum EIRP is calculated by adding the forward power to the calibrated source plus its appropriate gain value. These steps are repeated with the receiving antenna in both vertical and horizontal polarization. the difference between the gain of the horn and an isotropic antenna are taken into consideration

#### **Radiated spurious emissions**

: Frequency Range : 9 kHz ~ 10<sup>th</sup> Harmonics of highest channel fundamental frequency.

### 3.2 AWS – MOBILE FREQUENCY BLOCKS (1710 – 1780 MHz)

§27.5(h)

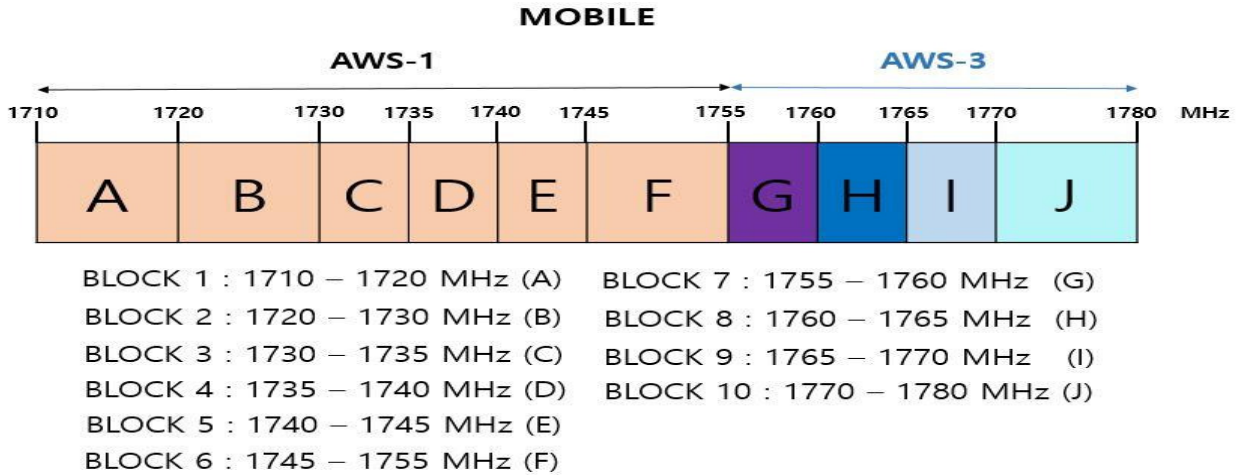

### 3.3 BLOCK B FREQUENCY RANGE (775 – 788 MHz)

§27.5(b)

746-758 MHz, 775-788 MHz, and 805-806 MHz bands. The following frequencies are available for licensing pursuant to this part in the 746-758 MHz, 775-788 MHz, and 805-806 MHz bands:

- (1) Two paired channels of 1 megahertz each are available for assignment in Block A in the 757-758 MHz and 787-788 MHz bands.
- (2) Two paired channels of 1 megahertz each are available for assignment in Block B in the 775-776 MHz and 805-806 MHz bands.
- (3) Two paired channels of 11 megahertz each are available for assignment in Block C in the 746-757 MHz and 776-787 MHz bands. In the event that no licenses for two channels in this Block C are assigned based on the results of the first auction in which such licenses were offered because the auction results do not satisfy the applicable reserve price, the spectrum in the 746-757 MHz and 776-787 MHz bands will instead be made available for assignment at a subsequent auction as follows:
  - (i) Two paired channels of 6 megahertz each available for assignment in Block C1 in the 746-752 MHz and 776-782 MHz bands.
  - (ii) Two paired channels of 5 megahertz each available for assignment in Block C2 in the 752-757 MHz and 782-787 MHz band.

### 3.4 PEAK-AVERAGE RATIO.

#### Test Procedure

Peak to Average Power Ratio is tested in accordance with KDB971168 D01 Power Meas License Digital Systems v02r02, October 17, 2014, Section 5.7.

#### - Section 5.7.1 CCDF Procedure

- a) Set resolution/measurement bandwidth  $\geq$  signal's occupied bandwidth;
- b) Set the number of counts to a value that stabilizes the measured CCDF curve;
- c) Set the measurement interval as follows:
  - 1) for continuous transmissions, set to 1 ms,
  - 2) for burst transmissions, employ an external trigger that is synchronized with the EUT burst timing sequence, or use the internal burst trigger with a trigger level that allows the burst to stabilize and set the measurement interval to a time that is less than or equal to the burst duration.
- d) Record the maximum PAPR level associated with a probability of 0.1%.

#### - Section 5.7.2 Alternate Procedure

Use one of the procedures presented in 5.1 to measure the total peak power and record as  $P_{Pk}$ . Use one of the applicable procedures presented 5.2 to measure the total average power and record as  $P_{Avg}$ . Determine the P.A.R. from:  $P.A.R_{(dB)} = P_{Pk (dBm)} - P_{Avg (dBm)}$  ( $P_{Avg}$  = Average Power + Duty cycle Factor)

#### 5.1.1 Peak power measurements with a spectrum/signal analyzer or EMI receiver

The following procedure can be used to determine the total peak output power.

- a) Set the RBW  $\geq$  OBW.
- b) Set VBW  $\geq 3 \times$  RBW.
- c) Set span  $\geq 2 \times$  RBW
- d) Sweep time = auto couple.
- e) Detector = peak.
- f) Ensure that the number of measurement points  $\geq$  span/RBW.
- g) Trace mode = max hold.
- h) Allow trace to fully stabilize.
- i) Use the peak marker function to determine the peak amplitude level.

### **5.2.2 Procedures for use with a spectrum/signal analyzer when EUT cannot be configured to transmit continuously and sweep triggering/signal gating cannot be properly implemented**

If the EUT cannot be configured to transmit continuously (burst duty cycle < 98%), then one of the following procedures can be used. The selection of the applicable procedure will depend on the characteristics of the measured burst duty cycle.

Measure the burst duty cycle with a spectrum/signal analyzer or EMC receiver can be used in zero-span mode if the response time and spacing between bins on the sweep are sufficient to permit accurate measurement of the burst on/off time of the transmitted signal.

#### **5.2.2.2 Constant burst duty cycle**

If the measured burst duty cycle is constant (i.e., duty cycle variations are less than  $\pm 2$  percent), then:

- a) Set span to at least 1.5 times the OBW.
- b) Set RBW = 1-5% of the OBW, not to exceed 1 MHz.
- c) Set VBW  $\geq 3 \times$  RBW.
- d) Number of points in sweep  $\geq 2 \times$  span / RBW. (This gives bin-to-bin spacing  $\leq$  RBW/2, so that narrowband signals are not lost between frequency bins.)
- e) Sweep time = auto.
- f) Detector = RMS (power averaging).
- g) Set sweep trigger to "free run".
- h) Trace average at least 100 traces in power averaging (i.e., RMS) mode.
- i) Compute power by integrating the spectrum across the OBW of the signal using the instrument's band power measurement function with band limits set equal to the OBW band edges. If the instrument does not have a band power function, sum the spectrum levels (in power units) at intervals equal to the RBW extending across the entire OBW of the spectrum.
- j) Add  $10 \log (1/x)$ , where  $x$  is the duty cycle, to the measured power in order to compute the average power during the actual transmission times (because the measurement represents an average over both the on and off times of the transmission).

For example, add  $10 \log (1/0.25) = 6$  dB if the duty cycle is a constant 25%.

### 3.5 OCCUPIED BANDWIDTH.

Test set-up

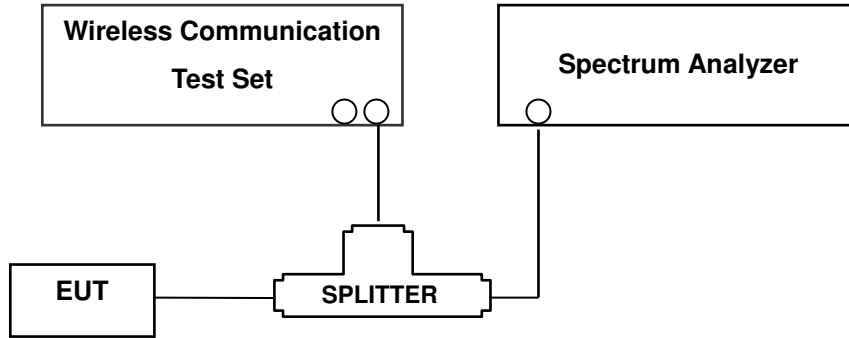

(Configuration of conducted Emission measurement)

The width of a frequency band such that, below the lower and above the upper frequency limits, the mean powers emitted are each equal to a specified percentage 0.5 % of the total mean power of a given emission.

#### Test Procedure

OBW is tested in accordance with KDB971168 D01 Power Meas License Digital Systems v02r02, October 17, 2014, Section 4.2.

The EUT makes a call to the communication simulator. The power was measured with R&S Spectrum Analyzer. All measurements were done at 3 channels(low, middle and high operational range.)

The conducted occupied bandwidth used the power splitter via EUT RF power connector between simulation base station and spectrum analyzer.

The communication simulator station system controlled a EUT to export maximum output power under transmission mode and specific channel frequency. Use OBW measurement function of Spectrum analyzer to measure 99 % occupied bandwidth

### 3.6 SPURIOUS AND HARMONIC EMISSIONS AT ANTENNA TERMINAL.

#### Test Procedure

Spurious and harmonic emissions at antenna terminal is tested in accordance with KDB971168 D01 Power Meas License Digital Systems v02r02, October 17, 2014, Section 6.0.

The level of the carrier and the various conducted spurious and harmonic frequencies is measured by means of a calibrated spectrum analyzer.

The spectrum is scanned from the lowest frequency generated in the equipment up to a frequency including its 10th harmonic. On any frequency outside a licensee's frequency block, the power of any emission shall be attenuated below the transmitter power (P) by at least  $43 + 10 \log(P)$  dB. Compliance with these provisions is based on the use of measurement instrumentation employing a resolution bandwidth of 1 MHz or greater. However, in the 100 kHz bands immediately outside and adjacent to the frequency block a resolution bandwidth of at least 30 kHz bandwidth may be employed. The emission bandwidth is defined as the width of the signal between two points, one below the carrier center frequency and one above the carrier center frequency

Additionally, for operations in the 776-788MHz band, the power of any emission outside the licensee's frequency band of operation shall be attenuated below the transmitted power (P) within the licensed band(s) of operation, measured in watts, in accordance with the following:

- (1) On any frequency outside the 776-788MHz band, the power of any emission shall be attenuated outside the band below the transmitter power (P) by at least  $43+10\log(P)$ dB.
- (2) On all frequencies between 763-775 and 793-805MHz, by a factor not less than  $65+10\log(P)$ dB in a 6.25kHz band segment.

For operations in the 788–793 MHz band, the power of any emission outside the licensee's frequency bands of operation shall be attenuated below the transmitter power (P) within the licensed band(s) of operation, measured in watts, in accordance with the following:

- (1) On all frequencies between 769–775 MHz and 799–805 MHz, by a factor not less than  $65 + 10 \log (P)$  dB in a 6.25 kHz band segment, for mobile and portable stations;
- (2) On any frequency between 775–788 MHz, above 805 MHz, and below 758 MHz, by at least  $43 + 10 \log (P)$  dB

**NOTES:** The analyzer plot offsets were determined by below conditions.

- For LTE Band 66, total offset 27.0 dB = 20 dB attenuator + 6 dB Divider + 1.0 dB RF cables.
- For LTE Band 13 total offset 26.8 dB = 20 dB attenuator + 6 dB Divider + 0.8 dB RF cables.

### 3.7 FREQUENCY STABILITY / VARIATION OF AMBIENT TEMPERATURE

#### Test Set-up

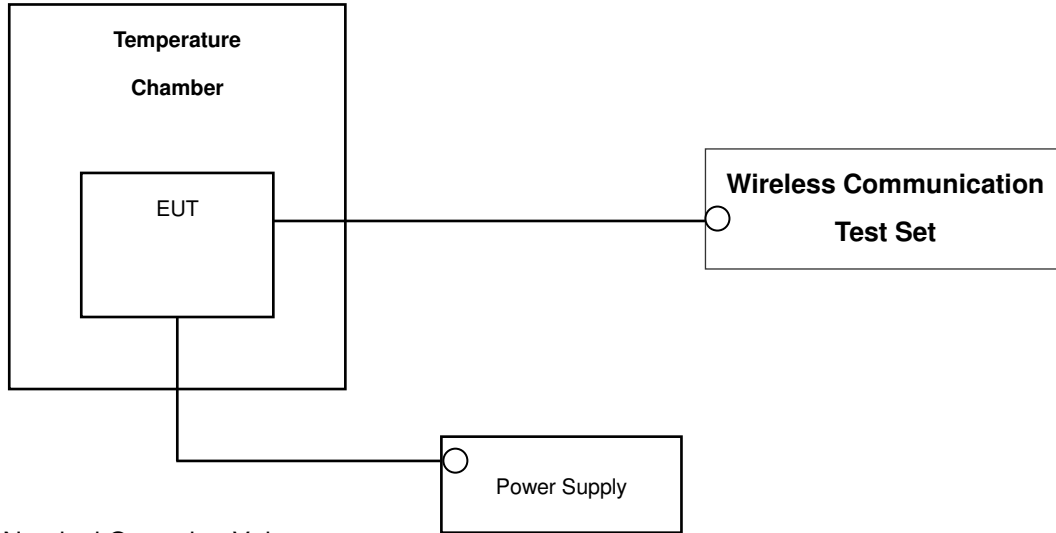

\* Nominal Operating Voltage

#### Test Procedure

Frequency stability is tested in accordance with ANSI/TIA-603-D-2010 section 2.2.2

The frequency stability of the transmitter is measured by:

- a.) **Temperature:** The temperature is varied from - 30 °C to + 50 °C using an environmental chamber.
- b.) **Primary Supply Voltage:** The primary supply voltage is varied from the end point to 100 % of the voltage normally at the input to the device or at the power supply terminals if cables are not normally supplied.

Specification — the frequency stability shall be sufficient to ensure that the fundamental emission stays within the authorized frequency block

#### Time Period and Procedure:

The carrier frequency of the transmitter is measured at room temperature (20°C to provide a reference).

1. The equipment is turned on in a "standby" condition for one minute before applying power to the transmitter. Measurement of the carrier frequency of the transmitter is made within one minute after applying power to the transmitter.
2. Frequency measurements are made at 10°C intervals ranging from -30°C to +50°C. A period of at least one half-hour is provided to allow stabilization of the equipment at each temperature level.

**NOTE: The EUT is tested down to the battery endpoint.**

## 4. LIST OF TEST EQUIPMENT

Manufacture	Model/ Equipment	Serial Number	Calibration Date	Calibration Interval	Calibration Due
REOHDE & SCHWARZ	SCU 18 / AMPLIFIER	10094	04/24/2017	Annual	04/24/2018
Wainwright	WHK1.2/15G-10EF/H.P.F	4	04/10/2017	Annual	04/10/2018
Wainwright	WHK3.3/18G-10EF/H.P.F	2	04/10/2017	Annual	04/10/2018
Hewlett Packard	11667B / Power Splitter	10545	02/15/2017	Annual	02/15/2018
Hewlett Packard	11667B / Power Splitter	11275	05/04/2017	Annual	05/04/2018
Agilent	E3632A/DC Power Supply	KR75303243	07/12/2016	Annual	07/12/2017
Schwarzbeck	UHAP/ Dipole Antenna	557	03/31/2017	Biennial	03/31/2019
Schwarzbeck	UHAP/ Dipole Antenna	558	03/31/2017	Biennial	03/31/2019
EXP	EX-TH400/ Chamber	None	05/31/2016	Annual	05/31/2017
Schwarzbeck	BBHA 9120D/ Horn Antenna	147	09/09/2016	Biennial	09/09/2018
Schwarzbeck	BBHA 9120D/ Horn Antenna	1298	10/14/2016	Biennial	10/14/2018
Schwarzbeck	BBHA 9170/ Horn Antenna(15~40GHz)	BBHA9170342	04/25/2017	Biennial	04/25/2019
Schwarzbeck	BBHA 9170/ Horn Antenna(15~35GHz)	BBHA9170124	04/25/2017	Biennial	04/25/2019
Agilent	N9020A/Signal Analyzer	MY51110074	11/28/2016	Annual	11/28/2017
Hewlett Packard	8493C/ATTENUATOR	17280	06/22/2016	Annual	06/22/2017
REOHDE & SCHWARZ	FSV40/Spectrum Analyzer	1307.9002K40-100931-NK	06/15/2016	Annual	06/15/2017
Agilent	8960 (E5515C)/ Base Station	MY48360800	10/19/2016	Annual	10/19/2017
Schwarzbeck	FMZB1513/ Loop Antenna(9kHz~30MHz)	1513-175	04/06/2017	Biennial	04/06/2019
Schwarzbeck	VULB9160/ Bilog Antenna	3150	09/30/2016	Biennial	09/30/2018
Schwarzbeck	VULB9160/ Bilog Antenna	3368	10/14/2016	Biennial	10/14/2018
REOHDE & SCHWARZ	ESU / EMI TEST RECEIVER	100346	08/11/2017	Annual	08/11/2018
Anritsu Corp.	MT8820C/Wideband Radio Communication Tester	6200863156	02/15/2017	Annual	02/15/2018
Anritsu Corp.	MT8820C/Wideband Radio Communication Tester	6201026545	02/13/2017	Annual	02/13/2018
Anritsu Corp.	MT8821C/Radio Communication Analyzer	6201502997	08/04/2016	Annual	08/04/2017
REOHDE & SCHWARZ	SMB100A/ SIGNAL GENERATOR (100kHz~40GHz)	177633	07/18/2016	Annual	07/18/2017



## 5. MEASUREMENT UNCERTAINTY

The measurement uncertainties shown below were calculated in accordance with the requirements of ANSI C63.4:2014.

All measurement uncertainty values are shown with a coverage factor of  $k = 2$  to indicate a 95 % level of confidence.

<b>Parameter</b>	<b>Expanded Uncertainty (<math>\pm</math>dB)</b>
Conducted Disturbance (150 kHz ~ 30 MHz)	1.82
Radiated Disturbance (9 kHz ~ 30 MHz)	3.40
Radiated Disturbance (30 MHz ~ 1 GHz)	4.80
Radiated Disturbance (1 GHz ~ 18 GHz)	6.07

## 6. SUMMARY OF TEST RESULTS

FCC Part Section(s)	Test Description	Test Limit	Test Condition	Test Result
2.1049	Occupied Bandwidth	N/A	CONDUCTED	PASS
2.1051, 27.53(g), 27.53(c)	Band Edge / Spurious and Harmonic Emissions at Antenna Terminal.	$< 43 + 10 \log_{10}(P[\text{Watts}])$ at Band Edge and for all-of-band emissions		PASS
27.50(d)(5)	Peak-Average Ratio	$< 13 \text{ dB}$		PASS
2.1046	* Conducted Output Power	N/A		PASS
2.1055, 27.54	Frequency stability / variation of ambient temperature	Emission must remain in band		PASS
27.50(b)(10)	Effective Radiated Power (Band 13)	$< 3 \text{ Watts max. ERP}$	RADIATED	PASS
27.50(d)(4)	Equivalent Isotropic Radiated Power (Band 4)	$< 1 \text{ Watts max. EIRP}$		PASS
2.1053, 27.53(g), 27.53(h)	Undesirable Out-of-Band Emissions	$< 43 + 10 \log_{10}(P[\text{Watts}])$ for all out-of-band emissions		PASS
2.1053, 27.53(f)	Undesirable Emissions in the 1559 – 1610 MHz band	$< -70\text{dBW/MHz EIRP (wideband)}$ $< -80\text{dBW EIRP (narrowband)}$		PASS

**Note regarding all Emission Mask test plots:**

The FCC limit is  $65 + 10\log_{10}(P_{\text{Watts}}) = -35 \text{ dBm}$  in a 6.25 kHz bandwidth. Since it was not possible to set the resolution bandwidth to 6.25 kHz with the available equipment, a bandwidth of 10 kHz was used instead to show compliance. By using a 10 kHz bandwidth, the limit was adjusted by  $10\log_{10}(10 \text{ kHz}/6.25 \text{ kHz}) = 2.04 \text{ dB}$ . Thus, the limit shown in all emission mask plots for all available modulation types was  $-35 \text{ dBm} + 2.04 \text{ dB} = -32.96 \text{ dBm}$ .

\*: See SAR Report

## 7. SAMPLE CALCULATION

### A. EIRP Sample Calculation

Mode	Ch./ Freq.		Measured Level(dBm)	Substitute LEVEL(dBm)	Ant. Gain (dBi)	C.L	Pol.	Limit	EIRP	
	channel	Freq.(MHz)						W	W	dBm
LTE Band66	132322	1745.0	-15.75	18.45	9.90	1.76	H	< 1.00	0.456	26.59

#### EIRP = Substitute LEVEL(dBm) + Ant. Gain – CL(Cable Loss)

- 1) The EUT mounted on a wooden tripod is 2.5 meter above test site ground level.
- 2) During the test , the turn table is rotated and the antenna height is found.
- 3) Record the field strength meter's level.
- 4) Replace the EUT with dipole/Horn antenna that is connected to a calibrated signal generator.
- 5) Increase the signal generator output till the field strength meter's level is equal to the item (3).
- 6) The signal generator output level with Ant. Gain and cable loss are the rating of equivalent isotropic radiated power (EIRP).

## B. Emission Designator

### QPSK Modulation

**Emission Designator = 4M48G7D**

LTE BW = 4.48 MHz

G = Phase Modulation

7 = Quantized/Digital Info

D = Data transmission; telemetry; telecommand

### 16QAM Modulation

**Emission Designator = 4M48W7D**

LTE BW = 4.48 MHz

W = main carrier modulated in a combination of two

or more of the following modes;

amplitude, angle, pulse

7 = Quantized/Digital Info

D = Data transmission; telemetry; telecommand

## 8. TEST DATA

### 8.1 EQUIVALENT ISOTROPIC RADIATED POWER (Band 66)

Freq (MHz)	Bandwidth	Modulation	Measured Level (dBm)	Substitute Level (dBm)	Ant. Gain(dBi)	C.L	Pol	Limit	EIRP	
								W	W	dBm
1710.7	1.4 MHz	QPSK	-22.18	10.40	9.37	1.92	H	< 1.00	0.061	17.85
		16-QAM	-23.41	9.17	9.37	1.92	H		0.046	16.62
1745.0		QPSK	-21.48	11.14	9.49	1.94	H		0.074	18.69
		16-QAM	-22.73	9.89	9.49	1.94	H		0.055	17.44
1779.3		QPSK	-21.22	11.44	9.60	1.96	H		0.081	19.08
		16-QAM	-22.29	10.37	9.60	1.96	H		0.063	18.01

#### Equivalent Isotropic Radiated Power Data (1.4 MHz Band66 LTE)

Note: All of RB size has been tested for emissions and EIRP, with the 1RB configuration observed as the worst case

Freq (MHz)	Bandwidth	Modulation	Measured Level (dBm)	Substitute Level (dBm)	Ant. Gain(dBi)	C.L	Pol	Limit	EIRP	
								W	W	dBm
1711.5	3 MHz	QPSK	-22.18	10.40	9.37	1.92	H	< 1.00	0.061	17.85
		16-QAM	-23.34	9.24	9.37	1.92	H		0.047	16.69
1745.0		QPSK	-21.26	11.36	9.49	1.94	H		0.078	18.91
		16-QAM	-22.57	10.05	9.49	1.94	H		0.058	17.60
1778.5		QPSK	-21.19	11.47	9.59	1.96	H		0.081	19.10
		16-QAM	-22.06	10.60	9.59	1.96	H		0.067	18.23

#### Equivalent Isotropic Radiated Power Data (3 MHz Band66 LTE)

Note: All of RB size has been tested for emissions and EIRP, with the 1RB configuration observed as the worst case

Freq (MHz)	Bandwidth	Modulation	Measured Level (dBm)	Substitute Level (dBm)	Ant. Gain(dBi)	C.L	Pol	Limit	EIRP	
								W	W	dBm
1712.5	5 MHz	QPSK	-22.39	10.20	9.37	1.92	H	< 1.00	0.058	17.65
		16-QAM	-23.48	9.11	9.37	1.92	H		0.045	16.56
1745.0		QPSK	-21.38	11.24	9.49	1.94	H		0.076	18.79
		16-QAM	-22.57	10.05	9.49	1.94	H		0.058	17.60
1777.5		QPSK	-21.22	11.44	9.59	1.96	H		0.081	19.07
		16-QAM	-22.35	10.31	9.59	1.96	H		0.062	17.94

**Equivalent Isotropic Radiated Power Data (5 MHz Band66 LTE)**

Note: All of RB size has been tested for emissions and EIRP, with the 1RB configuration observed as the worst case

Freq (MHz)	Bandwidth	Modulation	Measured Level (dBm)	Substitute Level (dBm)	Ant. Gain(dBi)	C.L	Pol	Limit	EIRP	
								W	W	dBm
1715.0	10 MHz	QPSK	-22.28	10.31	9.39	1.92	H	< 1.00	0.060	17.77
		16-QAM	-23.35	9.24	9.39	1.92	H		0.047	16.70
1745.0		QPSK	-21.41	11.21	9.49	1.94	H		0.075	18.76
		16-QAM	-22.43	10.19	9.49	1.94	H		0.059	17.74
1775.0		QPSK	-21.47	11.19	9.58	1.96	H		0.076	18.81
		16-QAM	-22.46	10.20	9.58	1.96	H		0.061	17.82

**Equivalent Isotropic Radiated Power Data (10 MHz Band66 LTE)**

Note: All of RB size has been tested for emissions and EIRP, with the 1RB configuration observed as the worst case

Freq (MHz)	Bandwidth	Modulation	Measured Level (dBm)	Substitute Level (dBm)	Ant. Gain(dBi)	C.L	Pol	Limit	EIRP	
								W	W	dBm
1717.5	15 MHz	QPSK	-22.12	10.46	9.40	1.92	H	< 1.00	0.062	17.94
		16-QAM	-23.54	9.04	9.40	1.92	H		0.045	16.52
1745.0		QPSK	-21.18	11.44	9.49	1.94	H		0.079	18.99
		16-QAM	-22.35	10.27	9.49	1.94	H		0.061	17.82
1772.5		QPSK	-21.21	11.44	9.57	1.95	H		0.081	19.06
		16-QAM	-22.31	10.34	9.57	1.95	H		0.063	17.96

**Equivalent Isotropic Radiated Power Data (15 MHz Band66 LTE)**

Note: All of RB size has been tested for emissions and EIRP, with the 1RB configuration observed as the worst case

Freq (MHz)	Bandwidth	Modulation	Measured Level (dBm)	Substitute Level (dBm)	Ant. Gain(dBi)	C.L	Pol	Limit	EIRP	
								W	W	dBm
1720.0	20 MHz	QPSK	-22.21	10.38	9.40	1.92	H	< 1.00	0.061	17.86
		16-QAM	-23.28	9.31	9.40	1.92	H		0.048	16.79
1745.0		QPSK	-20.95	11.67	9.49	1.94	H		0.084	19.22
		16-QAM	-22.04	10.58	9.49	1.94	H		0.065	18.13
1770.0		QPSK	-21.19	11.46	9.57	1.95	H		0.081	19.08
		16-QAM	-22.47	10.18	9.57	1.95	H		0.060	17.80

**Equivalent Isotropic Radiated Power Data (20 MHz Band66 LTE)**

Note: All of RB size has been tested for emissions and EIRP, with the 1RB configuration observed as the worst case

**NOTES:**

Equivalent Isotropic Radiated Power Measurements by Substitution Method

according to ANSI/TIA/EIA-603-D-2010 June 24, 2010:

The EUT was placed on a non-conductive styrofoam resin table 3-meters from the receive antenna. The receive antenna height and turntable rotation was adjusted for the highest reading on the receive spectrum analyzer. For LTE signals, RBW = 1-5% of the OBW, not to exceed 1MHz, VBW  $\geq 3 \times$  RBW, Detector = RMS. A Horn antenna was substituted in place of the EUT. This Horn antenna was driven by a signal generator and the level of the signal generator was adjusted to obtain the same receive spectrum analyzer reading. The conducted power at the terminals of the Horn antenna is measured. The difference between the gain of the horn and an isotropic antenna is taken into consideration and the EIRP is recorded.

Also, we have done x, y, z planes in EUT and horizontal and vertical polarization in detecting antenna. The worst case of the EUT is x plane in LTE mode. Also worst case of detecting Antenna is horizontal polarization in LTE mode.

## 8.2 EFFECTIVE RADIATED POWER (Band 13)

Freq (MHz)	Bandwidth	Modulation	Measured Level (dBm)	Substitute Level (dBm)	Ant. Gain(dBd)	C.L	Pol	Limit	ERP	
								W	W	dBm
779.5	5 MHz	QPSK	-33.85	26.63	-10.58	1.27	V	< 3.00	0.030	14.78
		16-QAM	-34.99	25.49	-10.58	1.27	V		0.023	13.64
782.0		QPSK	-34.21	26.43	-10.60	1.27	V		0.029	14.56
		16-QAM	-35.41	25.23	-10.60	1.27	V		0.022	13.36
784.5		QPSK	-34.34	26.45	-10.61	1.27	V		0.029	14.57
		16-QAM	-35.77	25.02	-10.61	1.27	V		0.021	13.14

### Effective Radiated Power Data (5 MHz Band 13 LTE)

Note: All of RB size has been tested for emissions and ERP, with the 1RB configuration observed as the worst case

Freq (MHz)	Bandwidth	Modulation	Measured Level (dBm)	Substitute Level (dBm)	Ant. Gain(dBd)	C.L	Pol	Limit	ERP	
								W	W	dBm
782.0	10 MHz	QPSK	-33.67	26.97	-10.60	1.27	V	< 3.00	0.032	15.10
		16-QAM	-34.89	25.75	-10.60	1.27	V		0.024	13.88

### Effective Radiated Power Data (5 MHz Band 13 LTE)

Note: All of RB size has been tested for emissions and ERP, with the 1RB configuration observed as the worst case

#### NOTES:

Effective Radiated Power Output Measurements by Substitution Method

according to ANSI/TIA/EIA-603-D-2010 June 24, 2010:

The EUT was placed on a non-conductive styrofoam resin table 3-meters from the receive antenna. The receive antenna height and turntable rotation was adjusted for the highest reading on the receive spectrum analyzer. For LTE signals, RBW = 1-5% of the OBW, not to exceed 1MHz, VBW ≥ 3 x RBW, Detector = RMS. A half-wave dipole was substituted in place of the EUT. This dipole antenna was driven by a signal generator and the level of the signal generator was adjusted to obtain the same receive spectrum analyzer reading. The conducted power at the terminals of the dipole is measured. The ERP is recorded.

Also, we have done x, y, z planes in EUT and horizontal and vertical polarization in detecting antenna. The worst case of the EUT is y plane in LTE mode. Also worst case of detecting Antenna is vertical polarization in LTE mode.



### 8.3 RADIATED SPURIOUS EMISSIONS

#### 8.3.1 RADIATED SPURIOUS EMISSIONS (1.4 MHz Band 66 LTE)

- ▣ OPERATING FREQUENCY: 1779.3 MHz
- ▣ MEASURED OUTPUT POWER: 19.08 dBm = 0.081 W
- ▣ MODULATION SIGNAL: 1.4 MHz QPSK
- ▣ DISTANCE: 3 meters
- ▣ LIMIT:  $43 + 10 \log_{10}(W) =$  32.08 dBc

Ch	Freq (MHz)	Measured Level (dBm)	Ant. Gain (dBi)	Substitute Level (dBm)	C.L	Pol	EIRP (dBm)	dBc
131979 (1710.7)	3,421.40	-57.67	12.19	-64.64	2.78	V	-55.23	74.31
	5,132.10	-56.49	12.76	-57.16	3.44	V	-47.84	66.92
	6,842.80	-57.11	12.06	-53.16	3.99	H	-45.09	64.17
132322 (1745.0)	3,490.00	-55.51	12.33	-61.86	2.81	V	-52.34	71.42
	5,235.00	-57.87	12.91	-59.28	3.47	H	-49.84	68.92
	6,980.00	-56.30	11.77	-51.04	4.04	V	-43.31	62.39
132665 (1779.3)	3,558.60	-58.27	12.39	-64.40	2.85	H	-54.86	73.94
	5,337.90	-55.59	13.04	-57.08	3.52	H	-47.56	66.64
	7,117.20	-57.09	11.73	-52.58	4.06	H	-44.91	63.99

- NOTES:**
1. Radiated Spurious Emission Measurements at 3 meters by Substitution Method according to ANSI/TIA/EIA-603-D-2010 June 24, 2010:
  2. We are performed all frequency to 10<sup>th</sup> harmonics from 9 kHz. Measurements above show only up to 3 maximum emissions noted, or would be lesser if no specific emissions from the EUT are recorded (ie: margin > 20 dB from the applicable limit) and considered that's already beyond the background noise floor.
  3. We have done x, y, z planes in EUT and horizontal and vertical polarization in detecting antenna.
  4. All of RB size has been tested for emissions and EIRP, with the 1RB configuration observed as the worst case
  5. We are performed 16QAM and QPSK modulations. The worst case data are reported in the table above.

### 8.3.2 RADIATED SPURIOUS EMISSIONS (3 MHz Band 66 LTE)

- ▣ OPERATING FREQUENCY: 1778.5 MHz
- ▣ MEASURED OUTPUT POWER: 19.10 dBm = 0.081 W
- ▣ MODULATION SIGNAL: 3 MHz QPSK
- ▣ DISTANCE: 3 meters
- ▣ LIMIT:  $43 + 10 \log_{10}(W) =$  32.10 dBc

Ch	Freq (MHz)	Measured Level (dBm)	Ant. Gain (dBi)	Substitute Level (dBm)	C.L	Pol	EIRP (dBm)	dBc
131987 (1711.5)	3,423.00	-55.84	12.19	-62.79	2.78	V	-53.38	72.48
	5,134.50	-56.32	12.76	-56.97	3.44	V	-47.65	66.75
	6,846.00	-56.09	12.60	-52.73	3.99	V	-44.12	63.22
132322 (1745.0)	3,490.00	-57.21	12.33	-63.56	2.81	V	-54.04	73.14
	5,235.00	-57.40	12.90	-58.87	3.47	V	-49.44	68.54
	6,980.00	-55.87	11.77	-50.61	4.04	V	-42.88	61.98
132657 (1778.5)	3,557.00	-58.03	12.39	-64.05	2.85	V	-54.51	73.61
	5,335.50	-57.28	13.04	-58.82	3.52	V	-49.30	68.40
	7,114.00	-55.54	11.73	-51.15	4.06	V	-43.48	62.58

- NOTES:**
1. Radiated Spurious Emission Measurements at 3 meters by Substitution Method according to ANSI/TIA/EIA-603-D-2010 June 24, 2010:
  2. We are performed all frequency to 10<sup>th</sup> harmonics from 9 kHz. Measurements above show only up to 3 maximum emissions noted, or would be lesser if no specific emissions from the EUT are recorded (ie: margin > 20 dB from the applicable limit) and considered that's already beyond the background noise floor.
  3. We have done x, y, z planes in EUT and horizontal and vertical polarization in detecting antenna.
  4. All of RB size has been tested for emissions and EIRP, with the 1RB configuration observed as the worst case
  5. We are performed 16QAM and QPSK modulations. The worst case data are reported in the table above.

### 8.3.3 RADIATED SPURIOUS EMISSIONS (5 MHz Band 66 LTE)

- ▣ OPERATING FREQUENCY: 1777.5 MHz
- ▣ MEASURED OUTPUT POWER: 19.07 dBm = 0.081 W
- ▣ MODULATION SIGNAL: 5 MHz QPSK
- ▣ DISTANCE: 3 meters
- ▣ LIMIT:  $43 + 10 \log_{10}(W) =$  32.07 dBc

Ch	Freq (MHz)	Measured Level (dBm)	Ant. Gain (dBi)	Substitute Level (dBm)	C.L	Pol	EIRP (dBm)	dBc
131997 (1712.5)	3,425.00	-57.07	12.19	-64.02	2.78	V	-54.61	73.68
	5,137.50	-57.06	12.76	-57.71	3.44	V	-48.39	67.46
	6,850.00	-55.89	12.04	-51.78	4.00	V	-43.74	62.81
132322 (1745.0)	3,490.00	-56.88	12.33	-63.23	2.81	V	-53.71	72.78
	5,235.00	-57.16	12.90	-58.63	3.47	V	-49.20	68.27
	6,980.00	-56.46	11.77	-51.20	4.04	V	-43.47	62.54
132647 (1777.5)	3,555.00	-57.28	12.39	-63.30	2.85	V	-53.76	72.83
	5,332.50	-57.64	13.04	-59.18	3.52	V	-49.66	68.73
	7,110.00	-55.77	11.73	-51.38	4.06	V	-43.71	62.78

- NOTES:**
1. Radiated Spurious Emission Measurements at 3 meters by Substitution Method according to ANSI/TIA/EIA-603-D-2010 June 24, 2010:
  2. We are performed all frequency to 10<sup>th</sup> harmonics from 9 kHz. Measurements above show only up to 3 maximum emissions noted, or would be lesser if no specific emissions from the EUT are recorded (ie: margin > 20 dB from the applicable limit) and considered that's already beyond the background noise floor.
  3. We have done x, y, z planes in EUT and horizontal and vertical polarization in detecting antenna.
  4. All of RB size has been tested for emissions and EIRP, with the 1RB configuration observed as the worst case
  5. We are performed 16QAM and QPSK modulations. The worst case data are reported in the table above.

### 8.3.4 RADIATED SPURIOUS EMISSIONS (10 MHz Band 66 LTE)

- ▣ OPERATING FREQUENCY: 1775.00 MHz
- ▣ MEASURED OUTPUT POWER: 18.81 dBm = 0.076 W
- ▣ MODULATION SIGNAL: 10 MHz QPSK
- ▣ DISTANCE: 3 meters
- ▣ LIMIT:  $43 + 10 \log_{10}(W) =$  31.81 dBc

Ch	Freq (MHz)	Measured Level (dBm)	Ant. Gain (dBi)	Substitute Level (dBm)	C.L	Pol	EIRP (dBm)	dBc
132022 (1715.0)	3,430.00	-57.29	12.21	-64.44	2.78	V	-55.01	73.82
	5,145.00	-57.78	12.77	-58.56	3.40	V	-49.19	68.00
	6,860.00	-56.44	12.01	-52.20	4.02	V	-44.21	63.02
132322 (1745.0)	3,490.00	-57.87	12.33	-64.22	2.81	V	-54.70	73.51
	5,235.00	-56.21	12.90	-57.68	3.47	V	-48.25	67.06
	6,980.00	-56.09	11.77	-50.83	4.04	V	-43.10	61.91
132622 (1775.0)	3,550.00	-57.00	12.39	-63.02	2.85	V	-53.48	72.29
	5,325.00	-57.88	13.03	-59.52	3.52	V	-50.01	68.82
	7,100.00	-57.00	11.73	-53.03	4.08	V	-45.38	64.19

- NOTES:**
1. Radiated Spurious Emission Measurements at 3 meters by Substitution Method according to ANSI/TIA/EIA-603-D-2010 June 24, 2010:
  2. We are performed all frequency to 10<sup>th</sup> harmonics from 9 kHz. Measurements above show only up to 3 maximum emissions noted, or would be lesser if no specific emissions from the EUT are recorded (ie: margin > 20 dB from the applicable limit) and considered that's already beyond the background noise floor.
  3. We have done x, y, z planes in EUT and horizontal and vertical polarization in detecting antenna.
  4. All of RB size has been tested for emissions and EIRP, with the 1RB configuration observed as the worst case
  5. We are performed 16QAM and QPSK modulations. The worst case data are reported in the table above.

### 8.3.5 RADIATED SPURIOUS EMISSIONS (15 MHz Band 66 LTE)

- ▣ OPERATING FREQUENCY: 1772.50 MHz
- ▣ MEASURED OUTPUT POWER: 19.06 dBm = 0.081 W
- ▣ MODULATION SIGNAL: 15 MHz QPSK
- ▣ DISTANCE: 3 meters
- ▣ LIMIT:  $43 + 10 \log_{10}(W) =$  32.06 dBc

Ch	Freq (MHz)	Measured Level (dBm)	Ant. Gain (dBi)	Substitute Level (dBm)	C.L	Pol	EIRP (dBm)	dBc
132047 (1717.5)	3,435.00	-57.41	12.21	-64.56	2.78	V	-55.13	74.19
	5,152.50	-55.23	12.79	-55.62	3.45	V	-46.28	65.34
	6,870.00	-56.96	11.99	-52.99	4.03	V	-45.03	64.09
132322 (1745.0)	3,490.00	-56.00	12.33	-62.35	2.81	V	-52.83	71.89
	5,235.00	-57.80	12.90	-59.27	3.47	V	-49.84	68.90
	6,980.00	-56.82	11.77	-51.56	4.04	V	-43.83	62.89
132597 (1772.5)	3,545.00	-57.87	12.39	-64.17	2.85	V	-54.63	73.69
	5,317.50	-57.38	13.02	-58.95	3.52	V	-49.45	68.51
	7,090.00	-56.12	11.73	-52.32	4.10	V	-44.69	63.75

- NOTES:**
1. Radiated Spurious Emission Measurements at 3 meters by Substitution Method according to ANSI/TIA/EIA-603-D-2010 June 24, 2010:
  2. We are performed all frequency to 10<sup>th</sup> harmonics from 9 kHz. Measurements above show only up to 3 maximum emissions noted, or would be lesser if no specific emissions from the EUT are recorded (ie: margin > 20 dB from the applicable limit) and considered that's already beyond the background noise floor.
  3. We have done x, y, z planes in EUT and horizontal and vertical polarization in detecting antenna.
  4. All of RB size has been tested for emissions and EIRP, with the 1RB configuration observed as the worst case
  5. We are performed 16QAM and QPSK modulations. The worst case data are reported in the table above.

### 8.3.6 RADIATED SPURIOUS EMISSIONS (20 MHz Band 66 LTE)

- ▣ OPERATING FREQUENCY: 1745.00 MHz
- ▣ MEASURED OUTPUT POWER: 19.22 dBm = 0.084 W
- ▣ MODULATION SIGNAL: 20 MHz QPSK
- ▣ DISTANCE: 3 meters
- ▣ LIMIT:  $43 + 10 \log_{10}(W) =$  32.22 dBc

Ch	Freq (MHz)	Measured Level (dBm)	Ant. Gain (dBi)	Substitute Level (dBm)	C.L	Pol	EIRP (dBm)	dBc
132072 (1720.0)	3,440.00	-57.51	12.23	-64.43	2.77	V	-54.97	74.19
	5,160.00	-57.90	12.80	-58.73	3.46	V	-49.39	68.61
	6,880.00	-57.10	11.97	-53.09	4.04	V	-45.16	64.38
132322 (1745.0)	3,490.00	-57.40	12.33	-63.75	2.81	V	-54.23	73.45
	5,235.00	-55.76	12.90	-57.23	3.47	V	-47.80	67.02
	6,980.00	-56.75	11.77	-51.49	4.04	V	-43.76	62.98
132572 (1770.0)	3,540.00	-56.02	12.39	-62.32	2.85	V	-52.78	72.00
	5,310.00	-56.37	13.02	-57.94	3.52	V	-48.44	67.66
	7,080.00	-55.37	11.73	-51.33	4.11	V	-43.71	62.93

- NOTES:**
1. Radiated Spurious Emission Measurements at 3 meters by Substitution Method according to ANSI/TIA/EIA-603-D-2010 June 24, 2010:
  2. We are performed all frequency to 10<sup>th</sup> harmonics from 9 kHz. Measurements above show only up to 3 maximum emissions noted, or would be lesser if no specific emissions from the EUT are recorded (ie: margin > 20 dB from the applicable limit) and considered that's already beyond the background noise floor.
  3. We have done x, y, z planes in EUT and horizontal and vertical polarization in detecting antenna.
  4. All of RB size has been tested for emissions and EIRP, with the 1RB configuration observed as the worst case
  5. We are performed 16QAM and QPSK modulations. The worst case data are reported in the table above.

### 8.3.7 RADIATED SPURIOUS EMISSIONS (5 MHz Band 13 LTE)

- ▣ OPERATING FREQUENCY: 779.50 MHz
- ▣ MEASURED OUTPUT POWER: 14.78 dBm = 0.030 W
- ▣ MODULATION SIGNAL: 5 MHz QPSK
- ▣ DISTANCE: 3 meters
- ▣ LIMIT:  $43 + 10 \log_{10}(W) =$  27.78 dBc

Ch	Freq (MHz)	Measured Level (dBm)	Ant. Gain (dBd)	Substitute Level (dBm)	C.L	Pol	ERP (dBm)	dBc
23205 (779.5)	2,338.5	-40.91	10.77	-48.41	2.27	V	-39.91	54.69
	3,118.0	-55.34	11.54	-62.00	2.65	V	-53.11	67.89
	3,897.5	-56.95	12.66	-75.33	2.98	H	-65.65	80.43
	4,677.0	-57.93	12.68	-76.03	3.28	H	-66.63	81.41
23230 (782.0)	2,346.0	-42.09	10.78	-49.46	2.27	V	-40.95	55.73
	3,128.0	-57.54	11.56	-64.19	2.65	H	-55.28	70.06
	3,910.0	-56.36	12.67	-61.71	2.96	H	-52.00	66.78
	4,692.0	-56.36	12.68	-61.41	3.27	V	-52.00	66.78
23255 (784.5)	2,353.5	-38.53	10.78	-45.89	2.27	V	-37.38	52.16
	3,138.0	-57.32	11.58	-64.01	2.66	V	-55.09	69.87
	3,922.5	-57.39	12.67	-62.60	2.98	H	-52.91	67.69
	4,707.0	-57.90	12.67	-62.81	3.28	H	-53.42	68.20

- NOTES:**
1. Radiated Spurious Emission Measurements at 3 meters by Substitution Method according to ANSI/TIA/EIA-603-D-2010 June 24, 2010:
  2. We are performed all frequency to 10<sup>th</sup> harmonics from 9 kHz. Measurements above show only up to 3 maximum emissions noted, or would be lesser if no specific emissions from the EUT are recorded (ie: margin > 20 dB from the applicable limit) and considered that's already beyond the background noise floor.
  3. We have done x, y, z planes in EUT and horizontal and vertical polarization in detecting antenna.
  4. All of RB size has been tested for emissions and ERP, with the 1RB configuration observed as the worst case
  5. We are performed 16QAM and QPSK modulations. The worst case data are reported in the table above.

### 8.3.8 RADIATED SPURIOUS EMISSIONS (10 MHz Band 13 LTE)

- ▣ OPERATING FREQUENCY: 782.00 MHz
- ▣ MEASURED OUTPUT POWER: 15.10 dBm = 0.032 W
- ▣ MODULATION SIGNAL: 10 MHz QPSK
- ▣ DISTANCE: 3 meters
- ▣ LIMIT:  $43 + 10 \log_{10}(W) =$  28.10 dBc

Ch	Freq (MHz)	Measured Level (dBm)	Ant. Gain (dBd)	Substitute Level (dBm)	C.L	Pol	ERP (dBm)	dBc
23230 (782.00)	2,346.0	-39.83	10.78	-48.27	2.27	V	-39.76	54.86
	3,128.0	-57.88	11.56	-65.65	2.65	H	-56.74	71.84
	3,910.0	-58.21	12.67	-65.66	2.96	H	-55.95	71.05

- NOTES:**
1. Radiated Spurious Emission Measurements at 3 meters by Substitution Method according to ANSI/TIA/EIA-603-D-2010 June 24, 2010:
  2. We are performed all frequency to 10<sup>th</sup> harmonics from 9 kHz. Measurements above show only up to 3 maximum emissions noted, or would be lesser if no specific emissions from the EUT are recorded (ie: margin > 20 dB from the applicable limit) and considered that's already beyond the background noise floor.
  3. We have done x, y, z planes in EUT and horizontal and vertical polarization in detecting antenna.
  4. All of RB size has been tested for emissions and ERP, with the 1RB configuration observed as the worst case
  5. We are performed 16QAM and QPSK modulations. The worst case data are reported in the table above.



**8.3.8.1 RADIATED SPURIOUS EMISSIONS (1559 ~ 1610 MHz Band)**

- ▣ OPERATING FREQUENCY: 779.5 MHz, 782.0 MHz, 784.5 MHz
- ▣ MEASURED OUTPUT POWER: 5 MHz QPSK
- ▣ DISTANCE: 3 meters
- ▣ WIDEBAND EMISSION LIMIT: -70 dBW/ MHz (= -40 dBm/ MHz)

Operating Frequency (MHz)	Measured Frequency (MHz)	EMISSION TYPE	Measured Level (dBm)	Ant. Gain (dBd)	Substitute Level (dBm)	C.L	Pol	ERP (dBm)	MARGIN (dB)
779.5	1588.6	WIDEBAND	-56.49	8.98	-70.88	1.86	H	-63.76	23.76
782.0	1577.3		-56.31	8.90	-70.35	1.84	H	-63.29	23.29
784.5	1585.0		-55.55	8.98	-69.94	1.86	H	-62.82	22.82

**8.3.8.2 RADIATED SPURIOUS EMISSIONS (1559 ~ 1610 MHz Band)**

- ▣ OPERATING FREQUENCY: 782.00 MHz
- ▣ MEASURED OUTPUT POWER: 10 MHz QPSK
- ▣ DISTANCE: 3 meters
- ▣ WIDEBAND EMISSION LIMIT: -70 dBW/ MHz (= -40 dBm/ MHz)

Operating Frequency (MHz)	Measured Frequency (MHz)	EMISSION TYPE	Measured Level (dBm)	Ant. Gain (dBd)	Substitute Level (dBm)	C.L	Pol	ERP (dBm)	MARGIN (dB)
782.0	1562.2	WIDEBAND	-55.97	8.82	-69.97	1.83	V	-62.98	22.98

### 8.4 PEAK-TO-AVERAGE RATIO

Band	Band Width	Frequency (MHz)	Modulation	Resource Block Size	Resource Block Offset	Data (dB )
66	1.4 MHz	1745.0	QPSK	6	0	4.40
			16-QAM	6		5.26
	3 MHz		QPSK	15		4.81
			16-QAM	15		5.61
	5 MHz		QPSK	25		4.63
			16-QAM	25		5.41
	10 MHz		QPSK	50		4.64
			16-QAM	50		5.47
	15 MHz		QPSK	75		4.60
			16-QAM	75		5.37
	20 MHz		QPSK	100		4.55
			16-QAM	100		5.42

- Plots of the EUT's Peak- to- Average Ratio are shown Page 55~ 60.

### 8.5 OCCUPIED BANDWIDTH

Band	Band Width	Frequency (MHz)	Modulation	Resource Block Size	Resource Block Offset	Data ( MHz )
66	1.4 MHz	1745.0	QPSK	6	0	1.0980
			16-QAM	6	0	1.0957
	3 MHz		QPSK	15	0	2.6989
			16-QAM	15	0	2.6987
	5 MHz		QPSK	25	0	4.4961
			16-QAM	25	0	4.4973
	10 MHz		QPSK	50	0	8.9876
			16-QAM	50	0	8.9427
	15 MHz		QPSK	75	0	13.386
			16-QAM	75	0	13.400
	20 MHz		QPSK	100	0	17.868
			16-QAM	100	0	17.886

Band	Band Width	Frequency (MHz)	Modulation	Resource Block Size	Resource Block Offset	Data ( MHz )
13	5 MHz	782.0	QPSK	25	0	4.5081
			16-QAM	25	0	4.4929
	10 MHz		QPSK	50	0	8.9711
			16-QAM	50	0	8.9549

- Plots of the EUT's Occupied Bandwidth are shown Page 47 ~ 54.

## 8.6 CONDUCTED SPURIOUS EMISSIONS

### ■FACTORS FOR FREQUENCY

Frequency Range (GHz)	Factor [dB]
0.03 – 1	25.27
1 – 5	27.98
5 – 10	28.59
10 – 15	29.12
15 – 20	29.49
Above 20	30.13

### NOTES:

Factor(dB) = Cable Loss + Attenuator +Power Splitter

Band	Band Width (MHz)	Frequency (MHz)	Frequency of Maximum Harmonic (GHz)	Factor (dB)	Measurement Maximum Data (dBm)	Result (dBm)	Limit (dBm)
66	1.4	1710.7	18.9165	29.49	-73.44	-43.95	-13.00
		1745.0	18.9155	29.49	-73.44	-43.95	
		1779.3	18.9275	29.49	-73.23	-43.74	
	3	1711.5	18.9195	29.49	-73.44	-43.95	
		1745.0	18.9200	29.49	-73.40	-43.91	
		1778.5	18.8995	29.49	-73.45	-43.96	
	5	1712.5	18.9180	29.49	-73.42	-43.93	
		1745.0	18.9380	29.49	-73.39	-43.90	
		1777.5	18.9310	29.49	-73.47	-43.98	
	10	1715.0	18.9045	29.49	-73.28	-43.79	
		1745.0	18.9205	29.49	-73.39	-43.90	
		1775.0	18.9055	29.49	-73.38	-43.89	
	15	1717.5	18.9255	29.49	-73.34	-43.85	
		1745.0	18.9265	29.49	-73.34	-43.85	
		1772.5	18.8965	29.49	-73.54	-44.05	
	20	1720.0	18.9400	29.49	-73.47	-43.98	
		1745.0	18.9140	29.49	-73.22	-43.73	
		1770.0	18.9105	29.49	-73.42	-43.93	

Band	Band Width (MHz)	Frequency (MHz)	Frequency of Maximum Harmonic (GHz)	Factor (dB)	Measurement Maximum Data (dBm)	Result (dBm)	Limit (dBm)
13	5	779.5	3.71873	27.980	-67.040	-39.060	-13.00
		782.0	3.71352	27.980	-66.920	-38.940	
		784.5	3.67823	27.980	-66.800	-38.820	
	10	782.0	3.71625	27.980	-67.220	-39.240	

**NOTES:**

1. Conducted Spurious Emissions was Tested QPSK Modulation, Resource Block Size 1 and Resource Block Offset 0
2. Result (dBm) = Measurement Maximum Data (dBm) + Factor (dB)

- Plots of the EUT's Conducted Spurious Emissions are shown Page 85 ~ 106.

**8.6.1 BAND EDGE**

- Plots of the EUT's Band Edge are shown Page 61 ~ 84.

## 8.7 FREQUENCY STABILITY / VARIATION OF AMBIENT TEMPERATURE

### 8.7.1 FREQUENCY STABILITY (1.4 MHz Band 66 LTE)

- ▣ OPERATING FREQUENCY: 1745.000,000 Hz
- ▣ CHANNEL: 132322 (1.4 MHz)
- ▣ REFERENCE VOLTAGE: 3.85 VDC
- ▣ DEVIATION LIMIT: Emission must remain in band

Voltage (%)	Power (VDC)	Temp. (°C)	Frequency (Hz)	Frequency Error (Hz)	Deviation (%)	ppm
100%	3.85	+20(Ref)	1744 999 951	3.9	0.000 000	0.002
100%		-30	1744 999 894	-56.9	-0.000 003	-0.033
100%		-20	1744 999 894	-56.7	-0.000 003	-0.032
100%		-10	1744 999 895	-55.6	-0.000 003	-0.032
100%		0	1744 999 906	-45.3	-0.000 003	-0.026
100%		+10	1744 999 894	-56.4	-0.000 003	-0.032
100%		+30	1744 999 898	-53.3	-0.000 003	-0.031
100%		+40	1744 999 895	-56.2	-0.000 003	-0.032
100%		+50	1744 999 890	-60.7	-0.000 003	-0.035
Batt. Endpoint		3.40	+20	1744 999 896	-55.3	-0.000 003

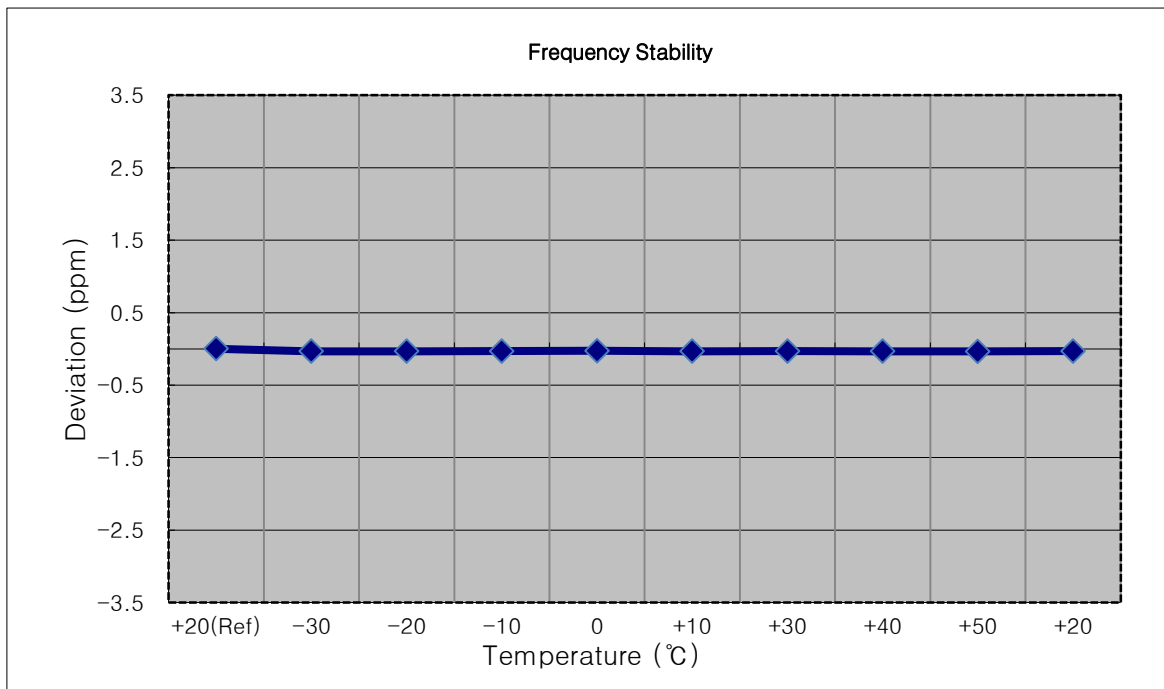

**8.7.2 FREQUENCY STABILITY (3 MHz Band 66 LTE)**

- ▣ OPERATING FREQUENCY: 1745.000,000 Hz
- ▣ CHANNEL: 132322 (3 MHz)
- ▣ REFERENCE VOLTAGE: 3.85 VDC
- ▣ DEVIATION LIMIT: Emission must remain in band

Voltage (%)	Power (VDC)	Temp. (°C)	Frequency (Hz)	Frequency Error (Hz)	Deviation (%)	ppm
100%	3.85	+20(Ref)	1744 999 945	0.0	0.000 000	0.000
100%		-30	1744 999 890	-54.7	-0.000 003	-0.031
100%		-20	1744 999 887	-57.7	-0.000 003	-0.033
100%		-10	1744 999 886	-58.8	-0.000 003	-0.034
100%		0	1744 999 889	-55.3	-0.000 003	-0.032
100%		+10	1744 999 894	-50.5	-0.000 003	-0.029
100%		+30	1744 999 887	-57.2	-0.000 003	-0.033
100%		+40	1744 999 896	-48.2	-0.000 003	-0.028
100%		+50	1744 999 887	-57.8	-0.000 003	-0.033
Batt. Endpoint		3.40	+20	1744 999 889	-56.0	-0.000 003

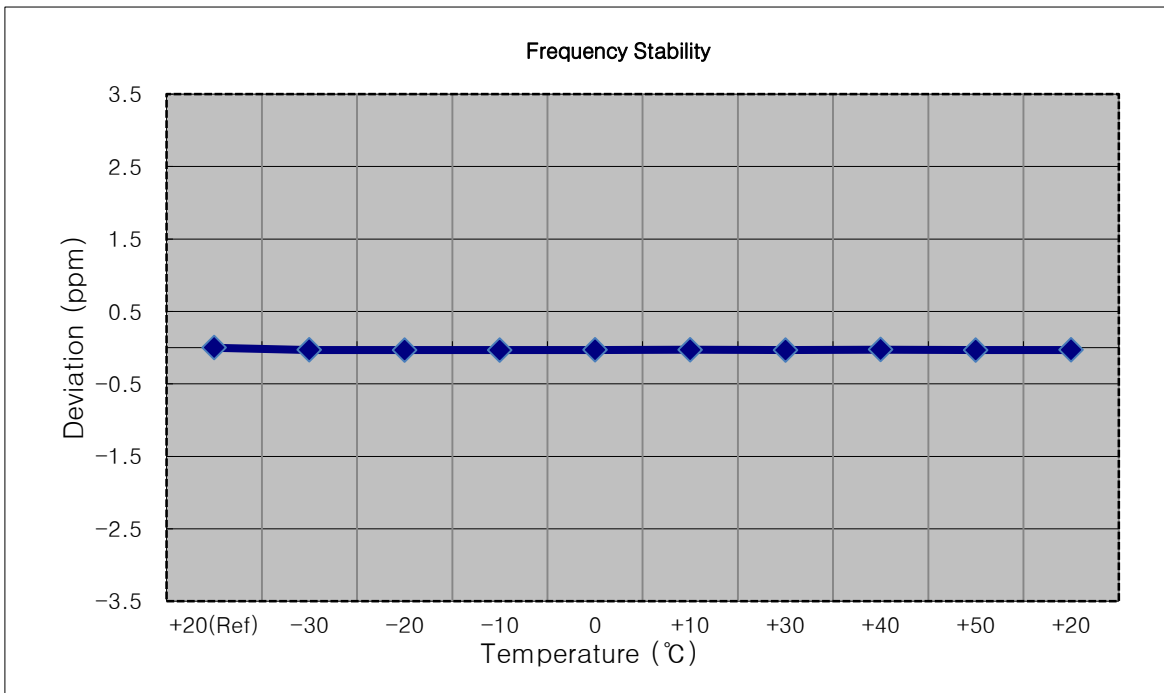

**8.7.3 FREQUENCY STABILITY (5 MHz Band 66 LTE)**

- ▣ OPERATING FREQUENCY: 1745.000,000 Hz
- ▣ CHANNEL: 132322 (5 MHz)
- ▣ REFERENCE VOLTAGE: 3.85 VDC
- ▣ DEVIATION LIMIT: Emission must remain in band

Voltage (%)	Power (VDC)	Temp. (°C)	Frequency (Hz)	Frequency Error (Hz)	Deviation (%)	ppm
100%	3.85	+20(Ref)	1744 999 946	0.0	0.000 000	0.000
100%		-30	1744 999 894	-52.8	-0.000 003	-0.030
100%		-20	1744 999 891	-55.2	-0.000 003	-0.032
100%		-10	1744 999 891	-55.0	-0.000 003	-0.032
100%		0	1744 999 891	-55.2	-0.000 003	-0.032
100%		+10	1744 999 891	-55.7	-0.000 003	-0.032
100%		+30	1744 999 887	-59.3	-0.000 003	-0.034
100%		+40	1744 999 893	-53.5	-0.000 003	-0.031
100%		+50	1744 999 894	-52.8	-0.000 003	-0.030
Batt. Endpoint		3.40	+20	1744 999 901	-45.6	-0.000 003

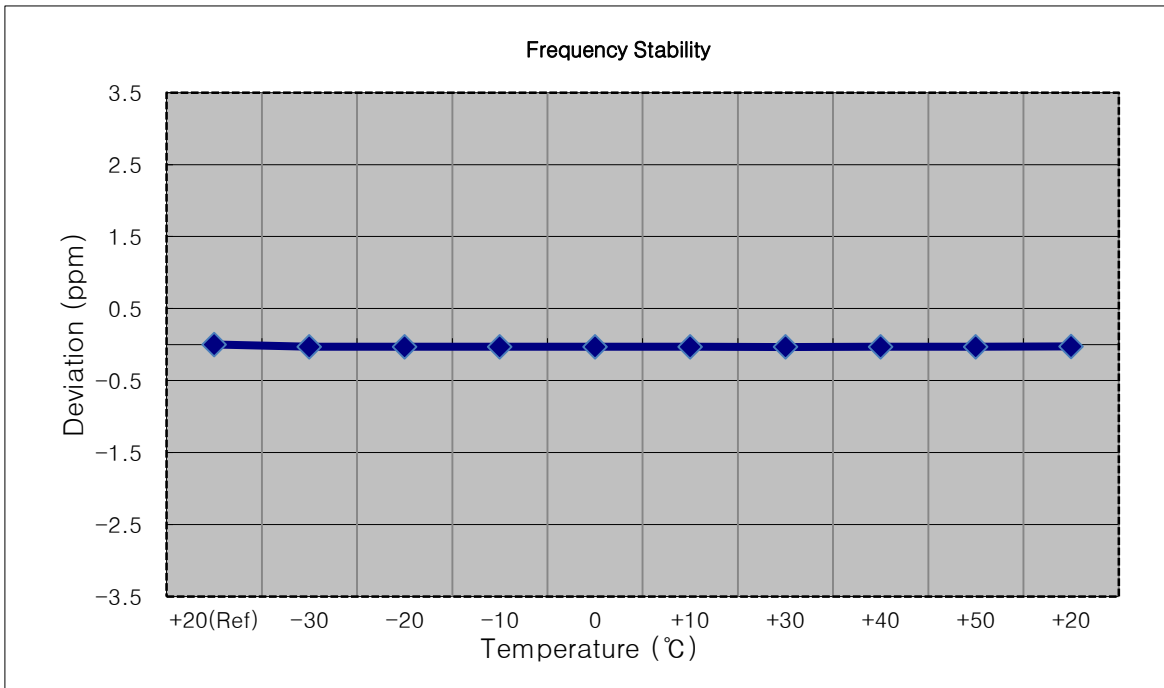



**8.7.4 FREQUENCY STABILITY (10 MHz Band 66 LTE)**

- ▣ OPERATING FREQUENCY: 1745.000,000 Hz
- ▣ CHANNEL: 132322 (10 MHz)
- ▣ REFERENCE VOLTAGE: 3.85 VDC
- ▣ DEVIATION LIMIT: Emission must remain in band

Voltage (%)	Power (VDC)	Temp. (°C)	Frequency (Hz)	Frequency Error (Hz)	Deviation (%)	ppm
100%	3.85	+20(Ref)	1744 999 941	0.0	0.000 000	0.000
100%		-30	1744 999 887	-53.4	-0.000 003	-0.031
100%		-20	1744 999 897	-44.0	-0.000 003	-0.025
100%		-10	1744 999 893	-47.4	-0.000 003	-0.027
100%		0	1744 999 895	-45.5	-0.000 003	-0.026
100%		+10	1744 999 885	-56.0	-0.000 003	-0.032
100%		+30	1744 999 888	-52.7	-0.000 003	-0.030
100%		+40	1744 999 886	-54.7	-0.000 003	-0.031
100%		+50	1744 999 882	-58.4	-0.000 003	-0.033
Batt. Endpoint		3.40	+20	1744 999 889	-51.5	-0.000 003

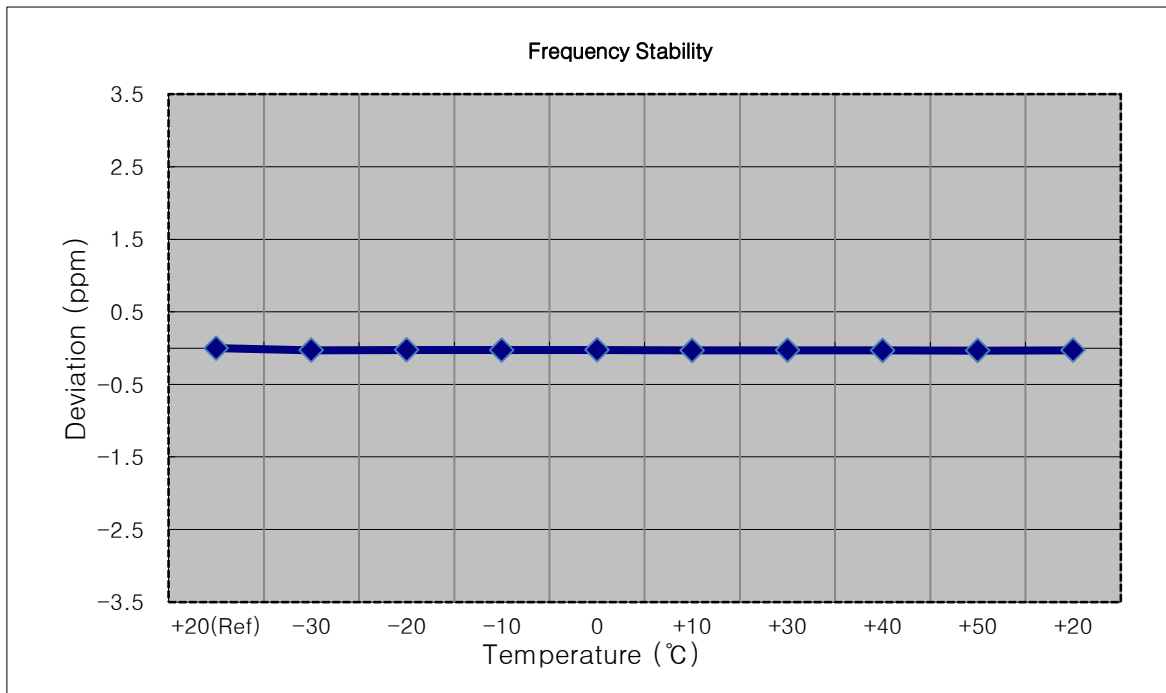

**8.7.5 FREQUENCY STABILITY (15 MHz Band 66 LTE)**

- ▣ OPERATING FREQUENCY: 1745.000,000 Hz
- ▣ CHANNEL: 132322 (15 MHz)
- ▣ REFERENCE VOLTAGE: 3.85 VDC
- ▣ DEVIATION LIMIT: Emission must remain in band

Voltage (%)	Power (VDC)	Temp. (°C)	Frequency (Hz)	Frequency Error (Hz)	Deviation (%)	ppm
100%	3.85	+20(Ref)	1744 999 946	0.0	0.000 000	0.000
100%		-30	1744 999 890	-56.0	-0.000 003	-0.032
100%		-20	1744 999 903	-43.8	-0.000 003	-0.025
100%		-10	1744 999 894	-52.6	-0.000 003	-0.030
100%		0	1744 999 894	-52.2	-0.000 003	-0.030
100%		+10	1744 999 891	-55.7	-0.000 003	-0.032
100%		+30	1744 999 888	-58.0	-0.000 003	-0.033
100%		+40	1744 999 886	-60.9	-0.000 003	-0.035
100%		+50	1744 999 896	-50.0	-0.000 003	-0.029
Batt. Endpoint		3.40	+20	1744 999 887	-59.5	-0.000 003

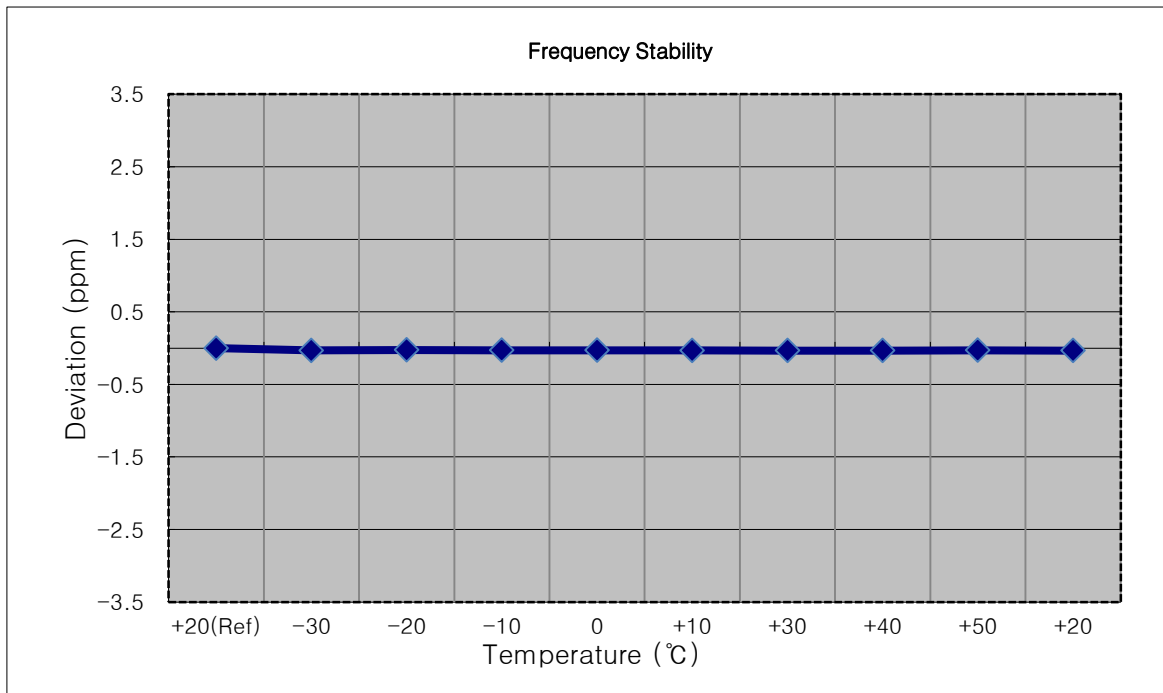

**8.7.6 FREQUENCY STABILITY (20 MHz Band 66 LTE)**

- ▣ OPERATING FREQUENCY: 1745.000,000 Hz
- ▣ CHANNEL: 132322 (20 MHz)
- ▣ REFERENCE VOLTAGE: 3.85 VDC
- ▣ DEVIATION LIMIT: Emission must remain in band

Voltage (%)	Power (VDC)	Temp. (°C)	Frequency (Hz)	Frequency Error (Hz)	Deviation (%)	ppm
100%	3.85	+20(Ref)	1744 999 947	0.0	0.000 000	0.000
100%		-30	1744 999 890	-57.0	-0.000 003	-0.033
100%		-20	1744 999 891	-55.6	-0.000 003	-0.032
100%		-10	1744 999 891	-55.8	-0.000 003	-0.032
100%		0	1744 999 896	-50.6	-0.000 003	-0.029
100%		+10	1744 999 889	-57.9	-0.000 003	-0.033
100%		+30	1744 999 887	-59.9	-0.000 003	-0.034
100%		+40	1744 999 892	-54.8	-0.000 003	-0.031
100%		+50	1744 999 898	-49.0	-0.000 003	-0.028
Batt. Endpoint		3.40	+20	1744 999 900	-46.6	-0.000 003

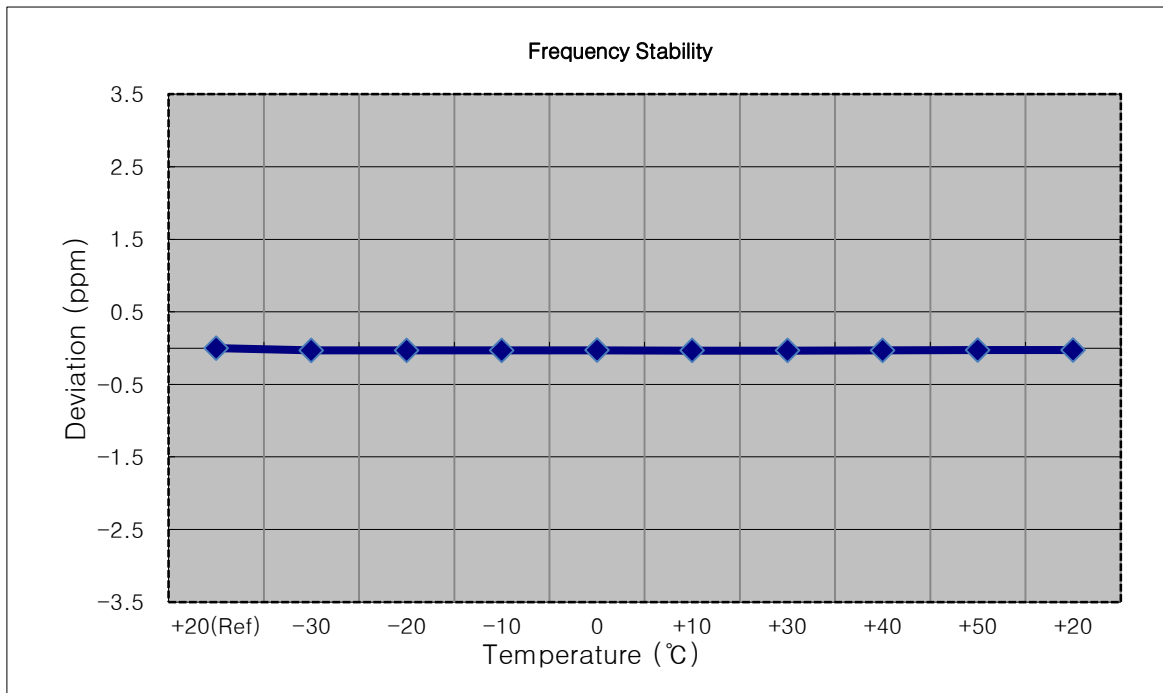

**8.7.7 FREQUENCY STABILITY (5 MHz Band 13 LTE)**

- ▣ OPERATING FREQUENCY: 782,000,000 Hz
- ▣ CHANNEL: 23230 (5 MHz)
- ▣ REFERENCE VOLTAGE: 3.85 VDC
- ▣ DEVIATION LIMIT: Emission must remain in band

Voltage (%)	Power (VDC)	Temp. (°C)	Frequency (Hz)	Frequency Error (Hz)	Deviation (%)	ppm
100%	3.85	+20(Ref)	781 999 997	0.00	0.000 000	0.0000
100%		-30	782 000 000	3.10	0.000 000	0.0040
100%		-20	781 999 999	2.30	0.000 000	0.0029
100%		-10	782 000 001	3.40	0.000 000	0.0043
100%		0	781 999 995	-2.10	0.000 000	-0.0027
100%		+10	782 000 000	2.90	0.000 000	0.0037
100%		+30	781 999 995	-2.50	0.000 000	-0.0032
100%		+40	782 000 000	3.00	0.000 000	0.0038
100%		+50	781 999 993	-3.90	0.000 000	-0.0050
Batt. Endpoint		3.40	+20	781 999 999	2.00	0.000 000

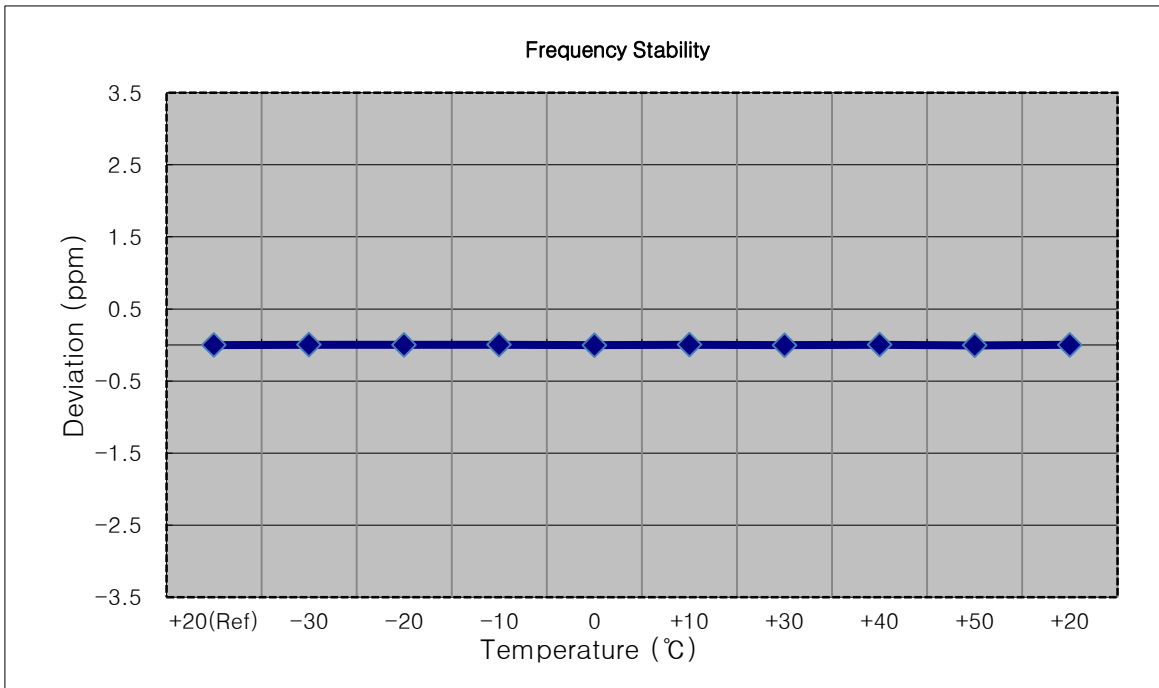

**8.7.8 FREQUENCY STABILITY (10 MHz Band 13 LTE)**

- ▣ OPERATING FREQUENCY: 782,000,000 Hz
- ▣ CHANNEL: 23230 (10 MHz)
- ▣ REFERENCE VOLTAGE: 3.85 VDC
- ▣ DEVIATION LIMIT: Emission must remain in band

Voltage (%)	Power (VDC)	Temp. (°C)	Frequency (Hz)	Frequency Error (Hz)	Deviation (%)	ppm
100%	3.85	+20(Ref)	781 999 998	0.00	0.000 000	0.0000
100%		-30	782 000 002	4.10	0.000 001	0.0052
100%		-20	781 999 995	-2.50	0.000 000	-0.0032
100%		-10	781 999 995	-2.80	0.000 000	-0.0036
100%		0	782 000 000	2.50	0.000 000	0.0032
100%		+10	782 000 001	3.00	0.000 000	0.0038
100%		+30	782 000 001	3.20	0.000 000	0.0041
100%		+40	782 000 000	2.50	0.000 000	0.0032
100%		+50	782 000 001	3.60	0.000 000	0.0046
Batt. Endpoint	3.40	+20	782 000 001	3.40	0.000 000	0.0043

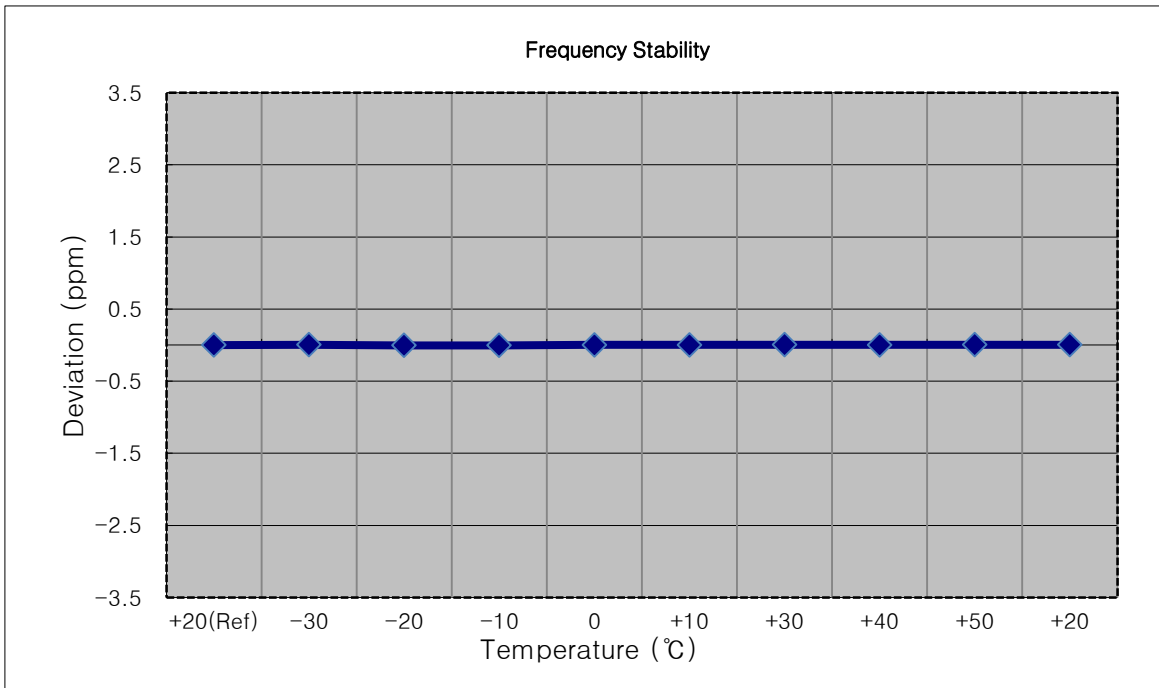

## 9. TEST PLOTS

BAND 66. Occupied Bandwidth Plot (1.4M BW Ch.132322 QPSK RB 6)

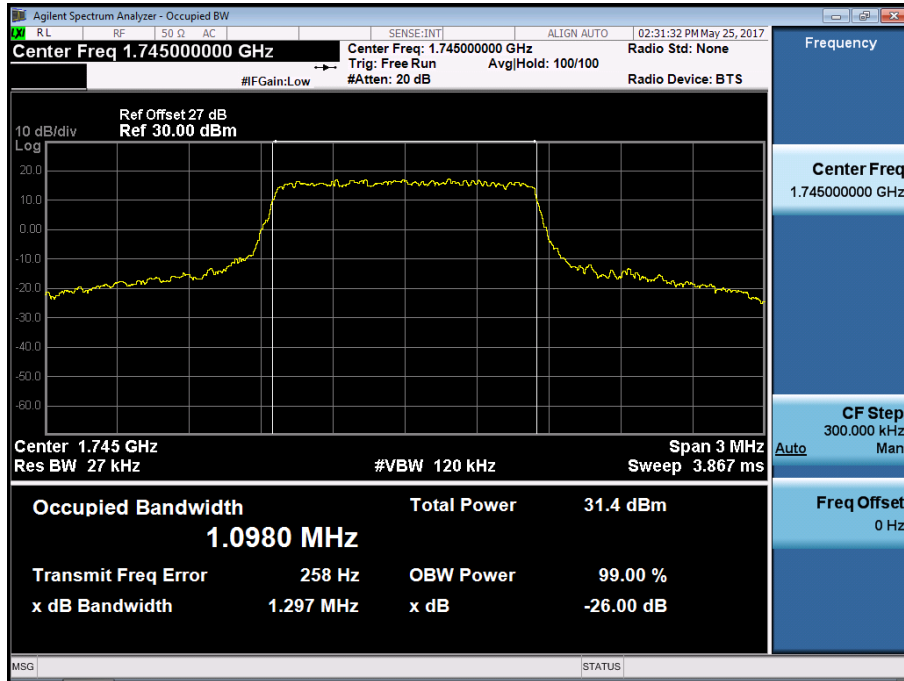

BAND 66. Occupied Bandwidth Plot (1.4M BW Ch.132322 16QAM RB 6)

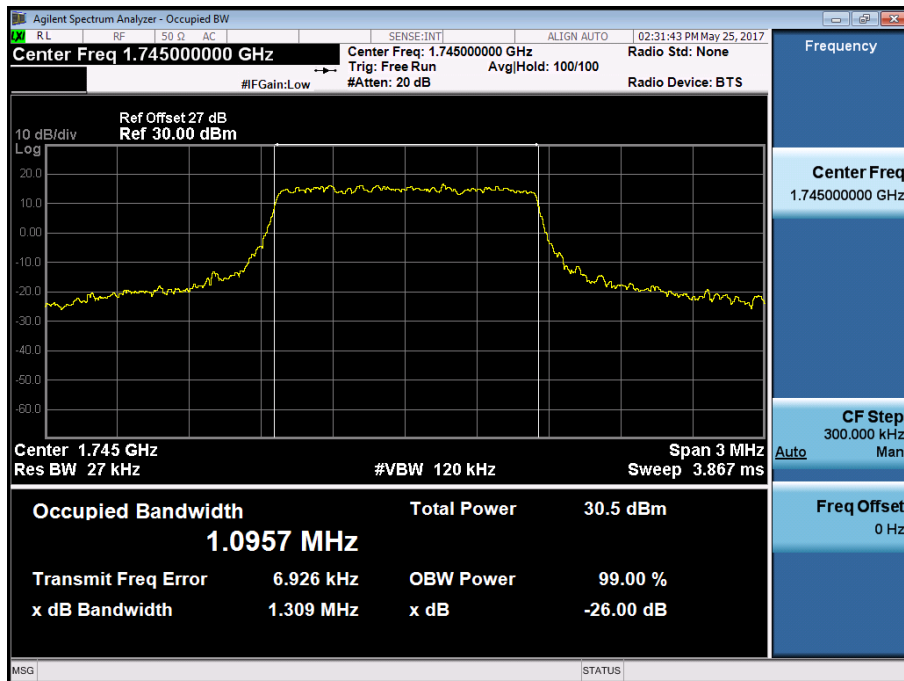

BAND 66. Occupied Bandwidth Plot (3M BW Ch.132322 QPSK RB 15)

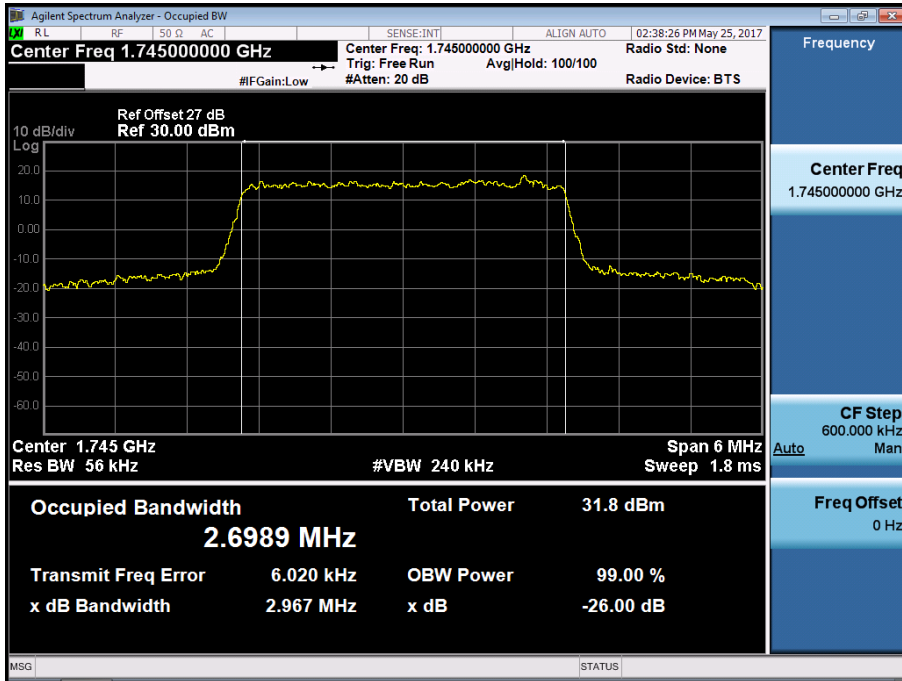

BAND 66. Occupied Bandwidth Plot (3M BW Ch.132322 16QAM RB 15)

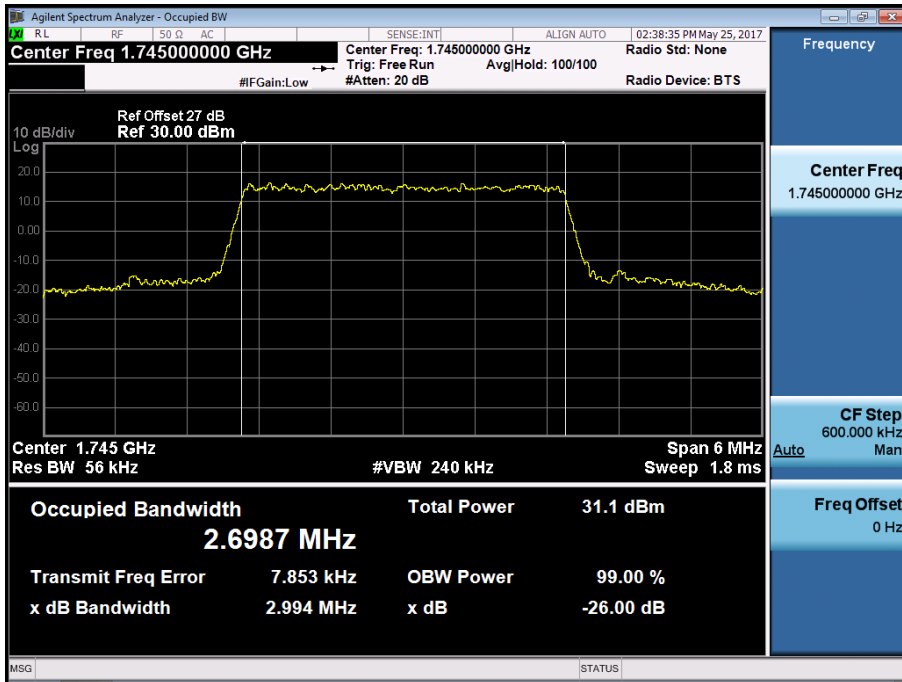



BAND 66. Occupied Bandwidth Plot (5M BW Ch.132322 QPSK RB 25)

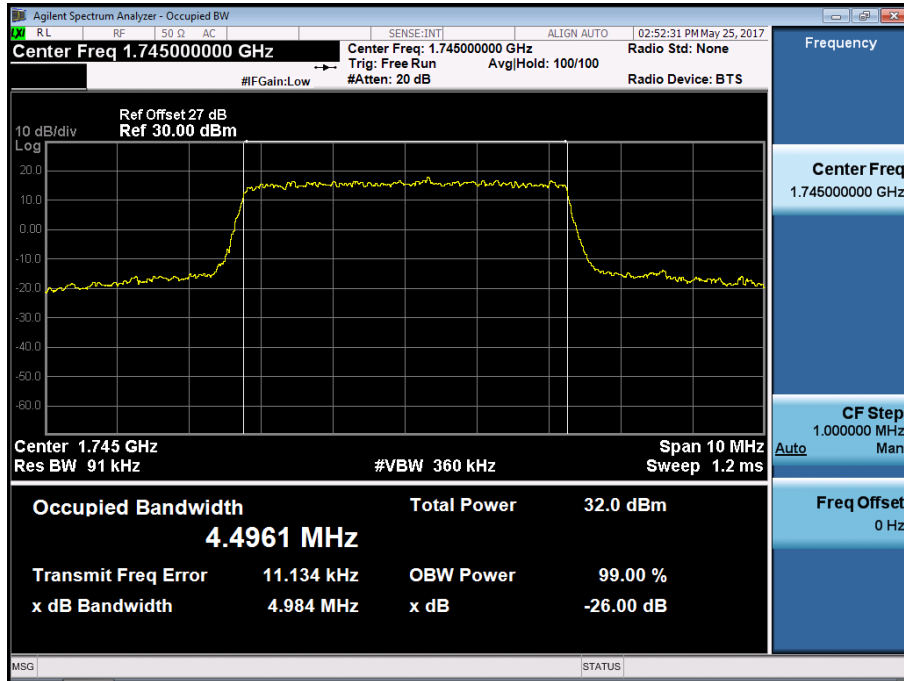

BAND 66. Occupied Bandwidth Plot (5M BW Ch.132322 16QAM RB 25)

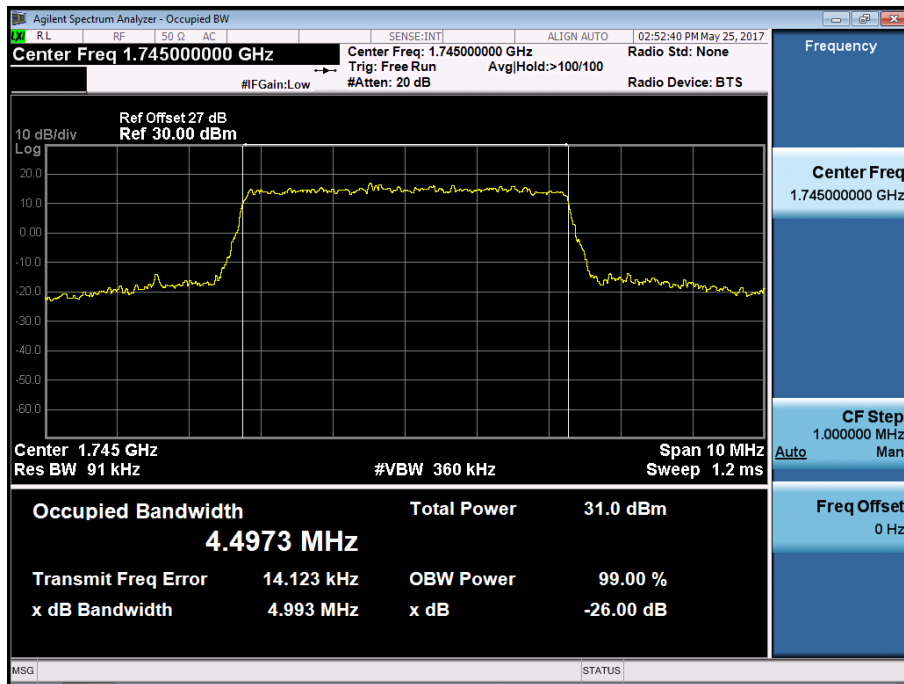

BAND 66. Occupied Bandwidth Plot (10M BW Ch.132322 QPSK RB 50)

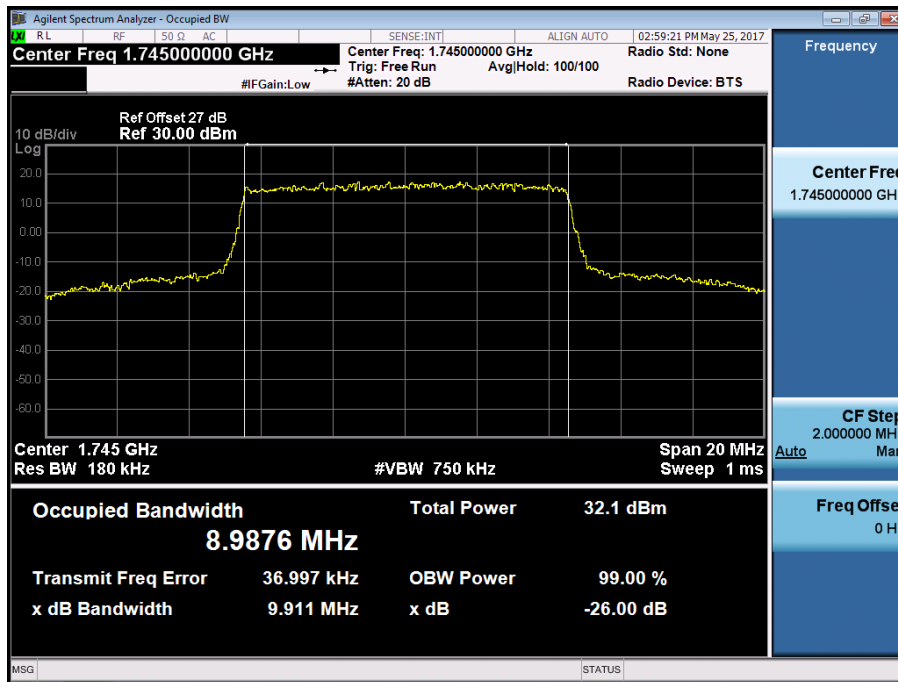

BAND 66. Occupied Bandwidth Plot (10M BW Ch.132322 16QAM RB 50)

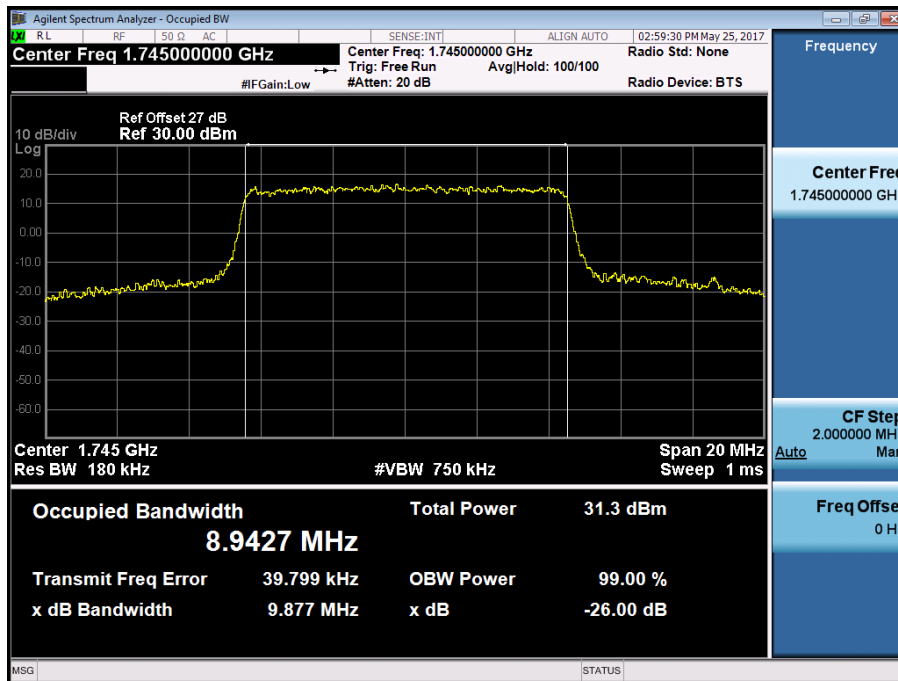

BAND 66. Occupied Bandwidth Plot (15M BW Ch.132322 QPSK RB 75)

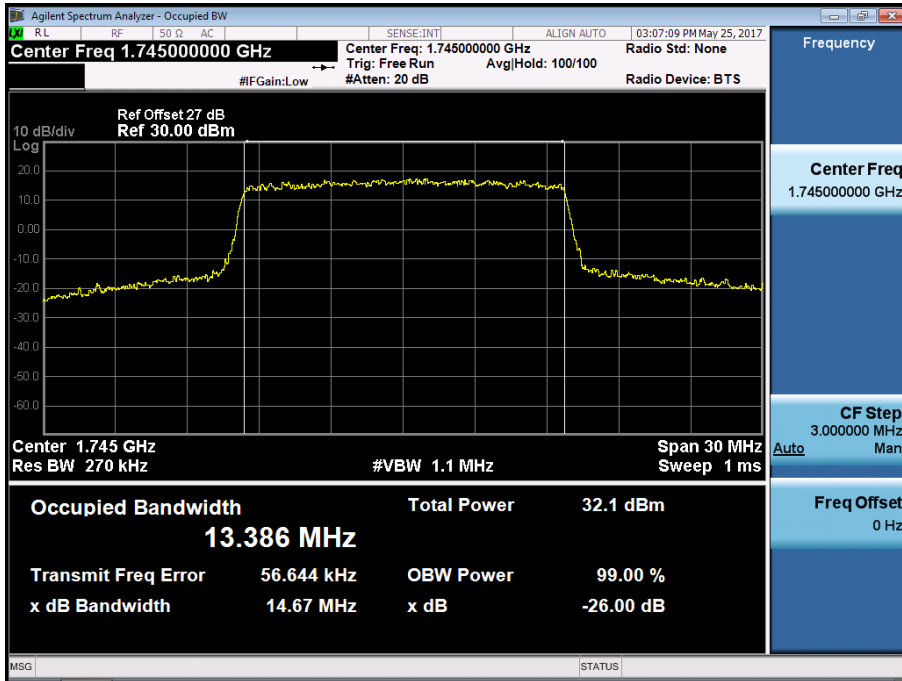

BAND 66. Occupied Bandwidth Plot (15M BW Ch.132322 16QAM RB 75)

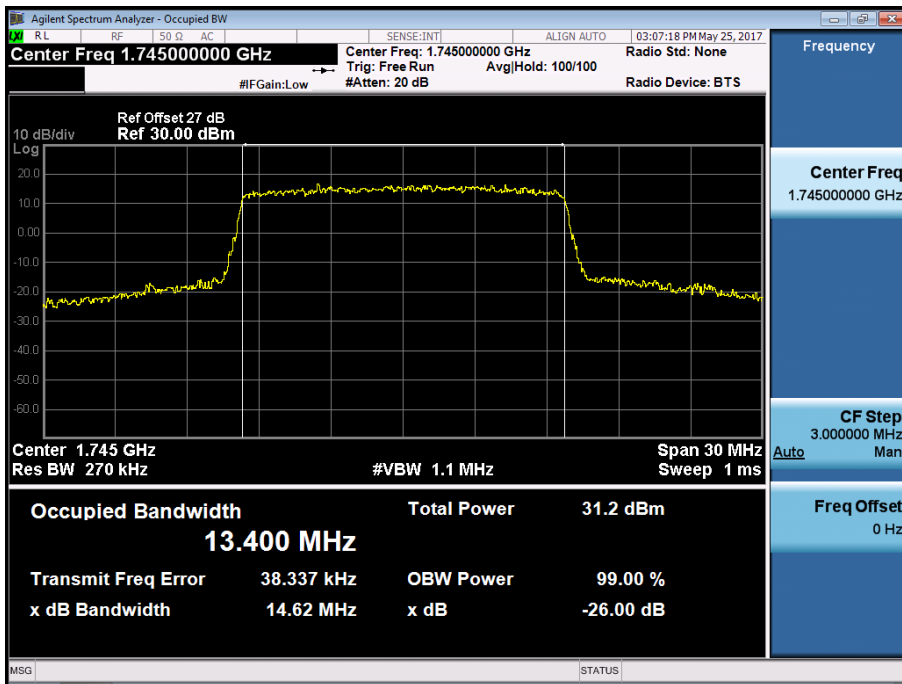

BAND 66. Occupied Bandwidth Plot (20M BW Ch.132322 QPSK RB 100)

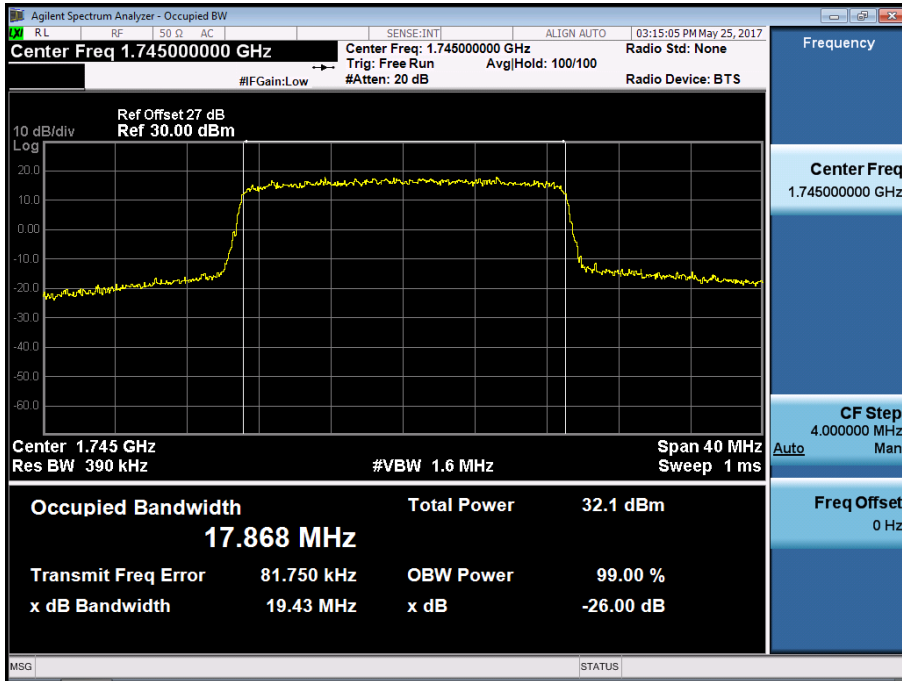

BAND 66. Occupied Bandwidth Plot (20M BW Ch.132322 16QAM RB 100)

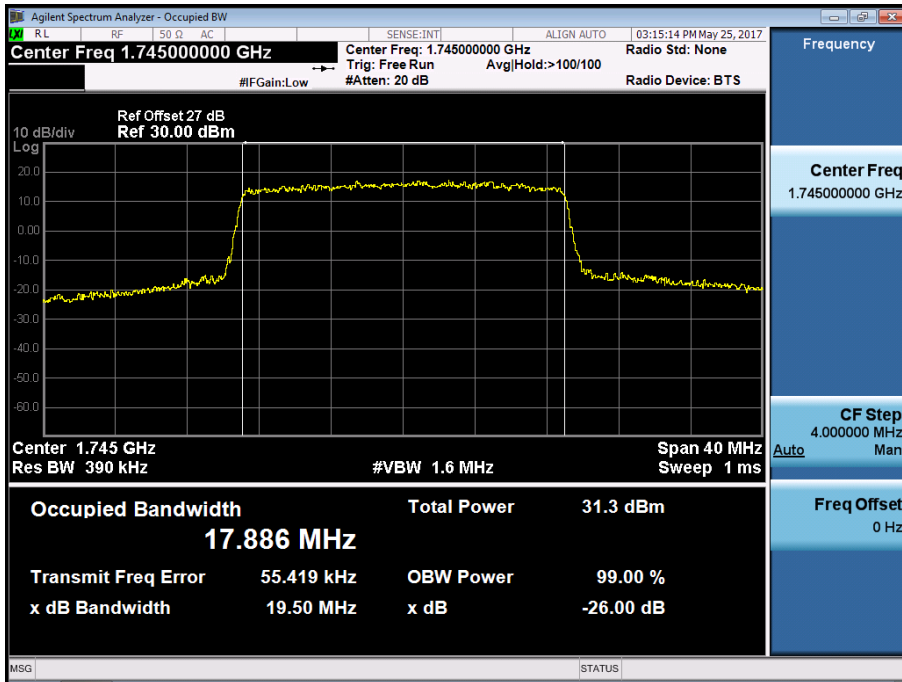

BAND 13. Occupied Bandwidth Plot (Ch.23230 QPSK RB 25) 5 MHz

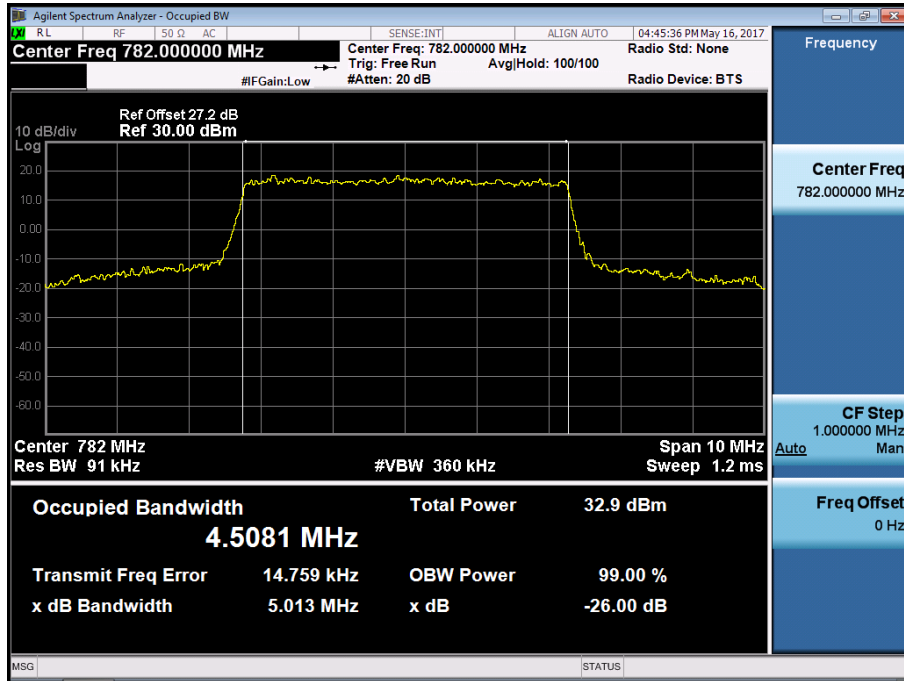

BAND 13. Occupied Bandwidth Plot (Ch.23230 16-QAM RB 25) 5 MHz

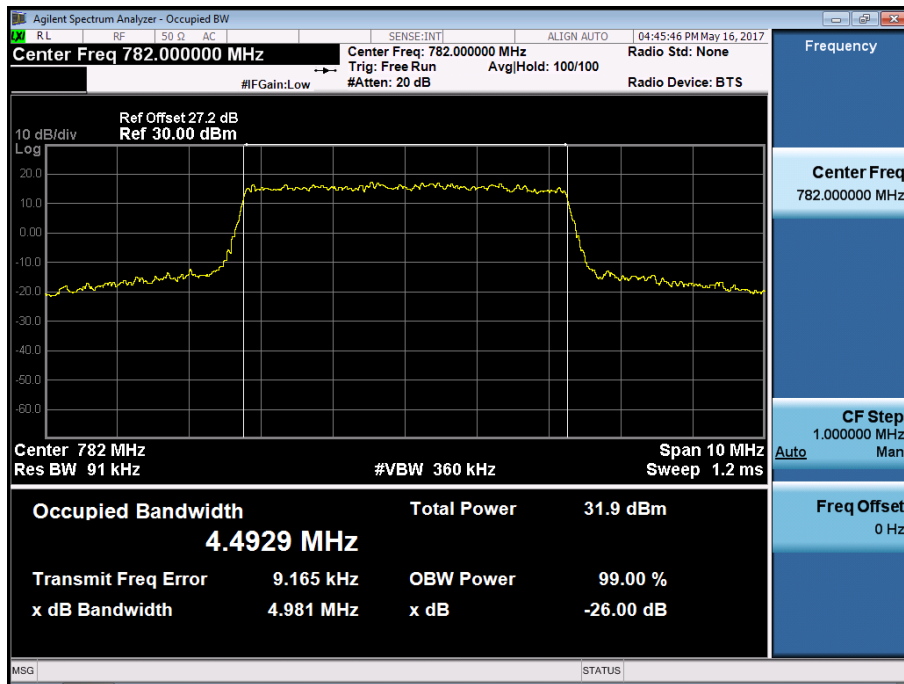

BAND 13. Occupied Bandwidth Plot (Ch.23230 QPSK RB 50) 10 MHz

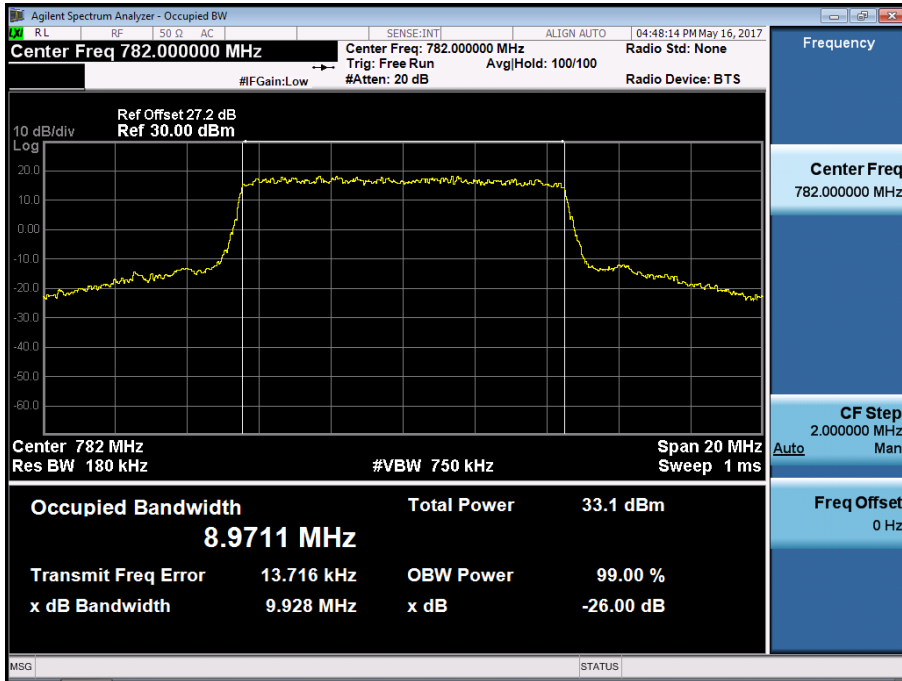

BAND 13. Occupied Bandwidth Plot (Ch.23230 16-QAM RB 50) 10 MHz

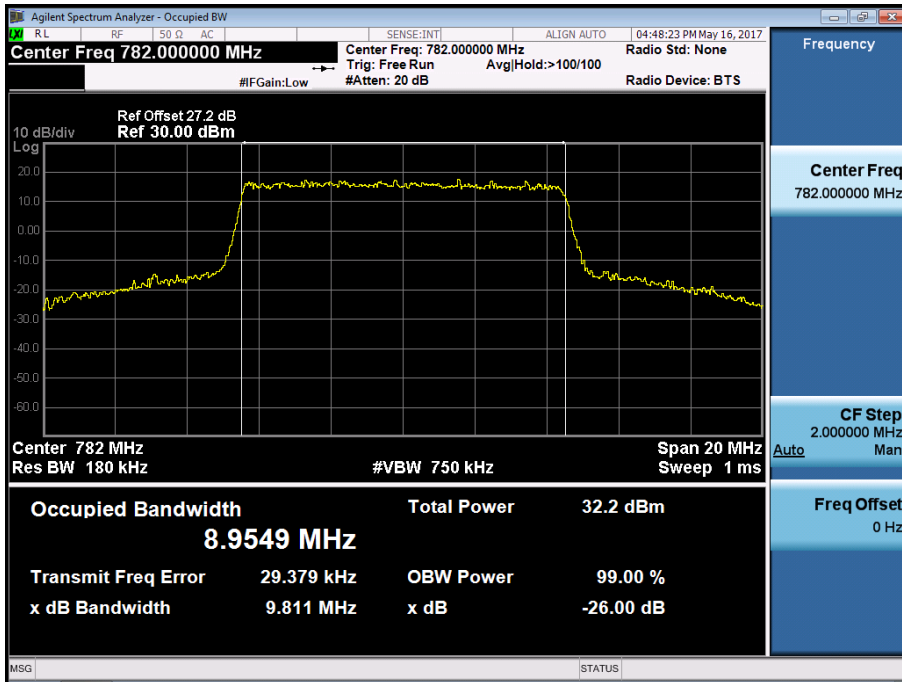

BAND 66. PAR Plot (1.4M BW\_Ch.132322\_QPSK\_RB6\_0)

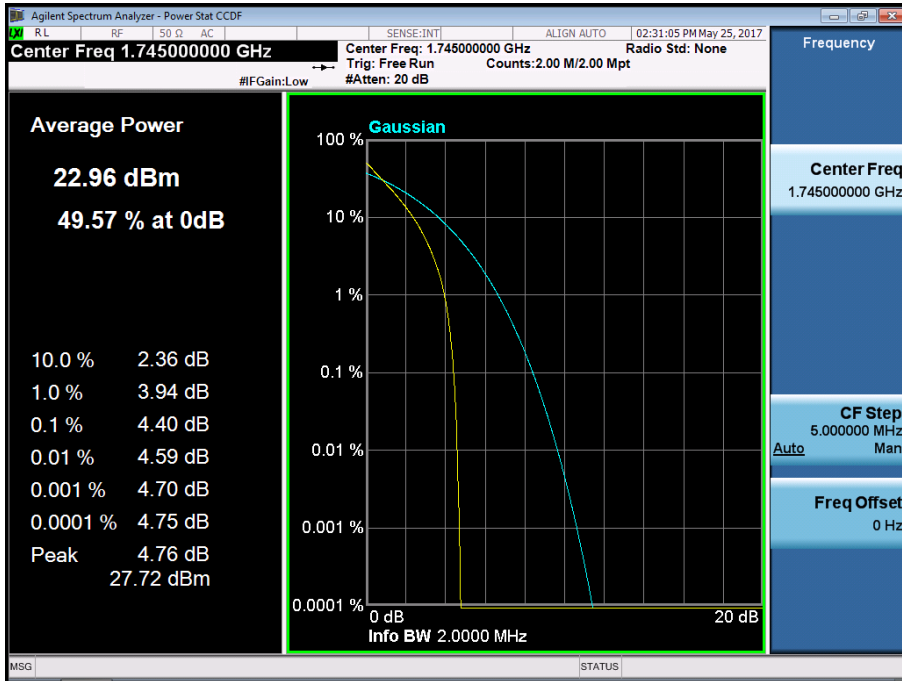

BAND 66. PAR Plot (1.4M BW\_Ch.132322\_16QAM\_RB6\_0)

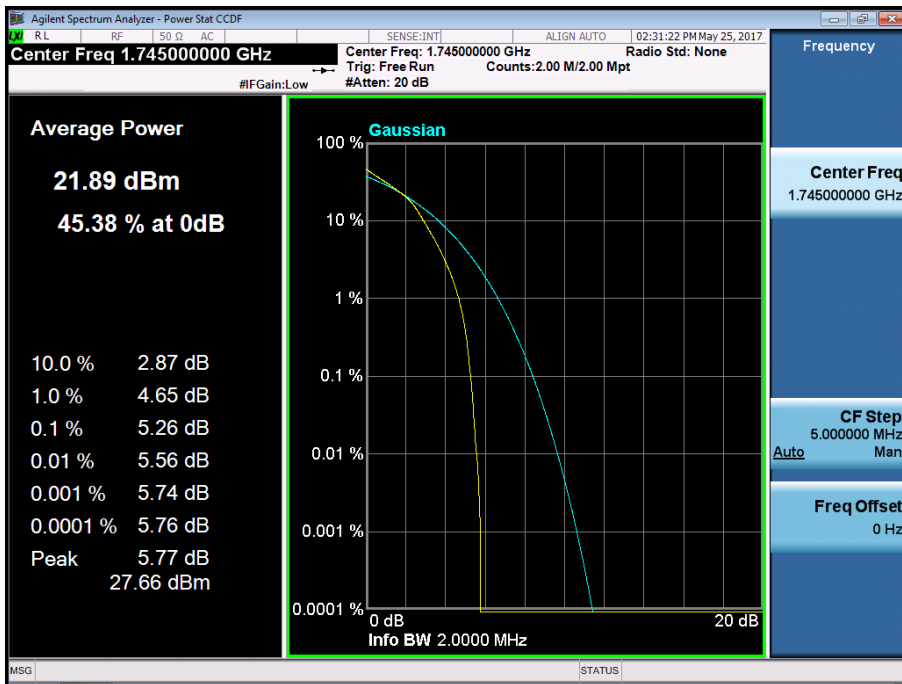

BAND 66. PAR Plot (3M BW\_Ch.132322\_QPSK\_RB15\_0)

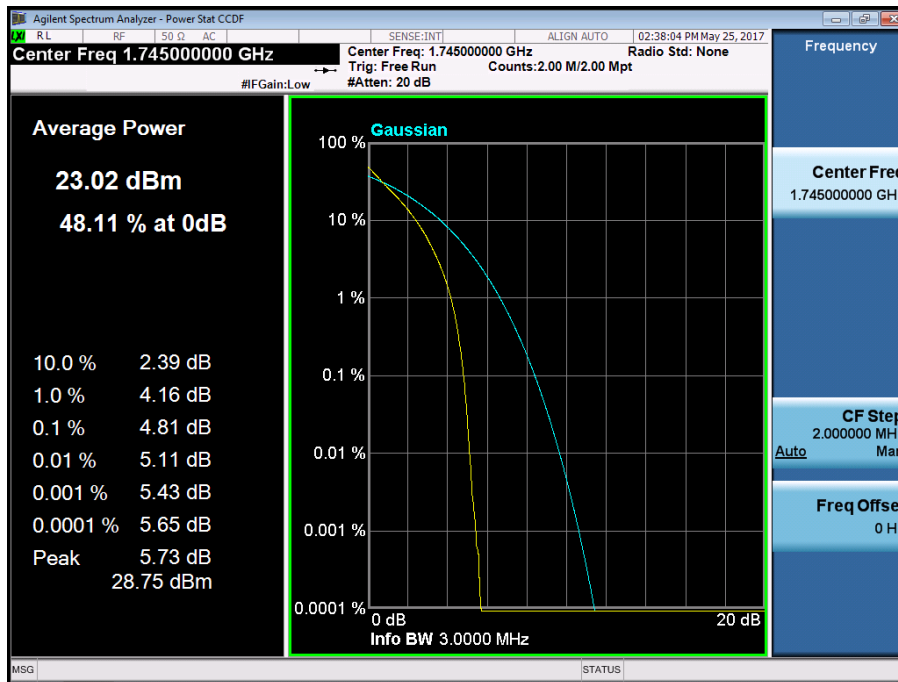

BAND 66. PAR Plot (3M BW\_Ch.132322\_16QAM\_RB15\_0)

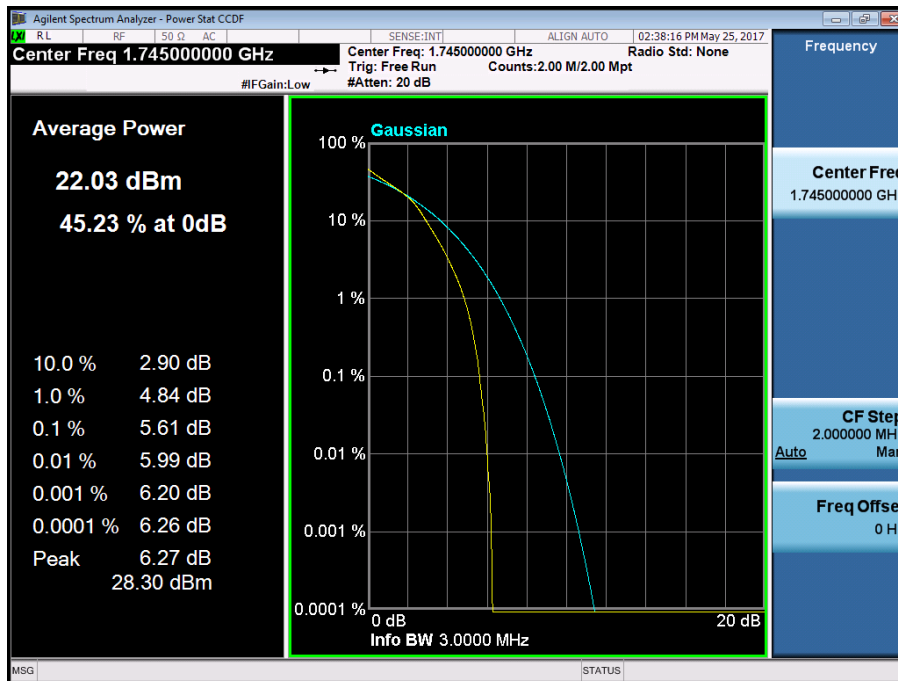



BAND 66. PAR Plot (5M BW\_Ch.132322\_QPSK\_RB25\_0)

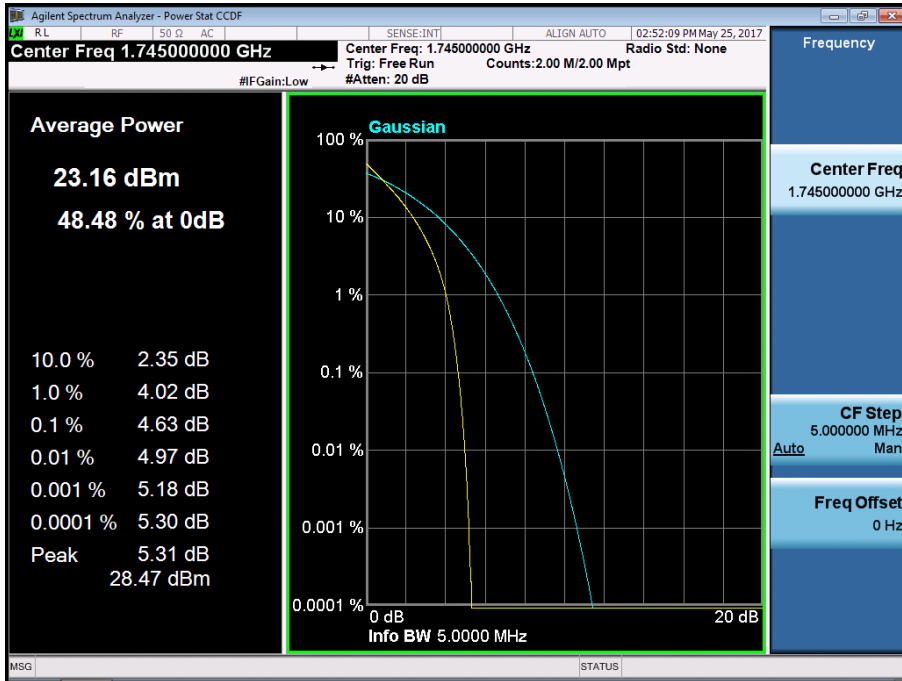

BAND 66. PAR Plot (5M BW\_Ch.132322\_16QAM\_RB25\_0)

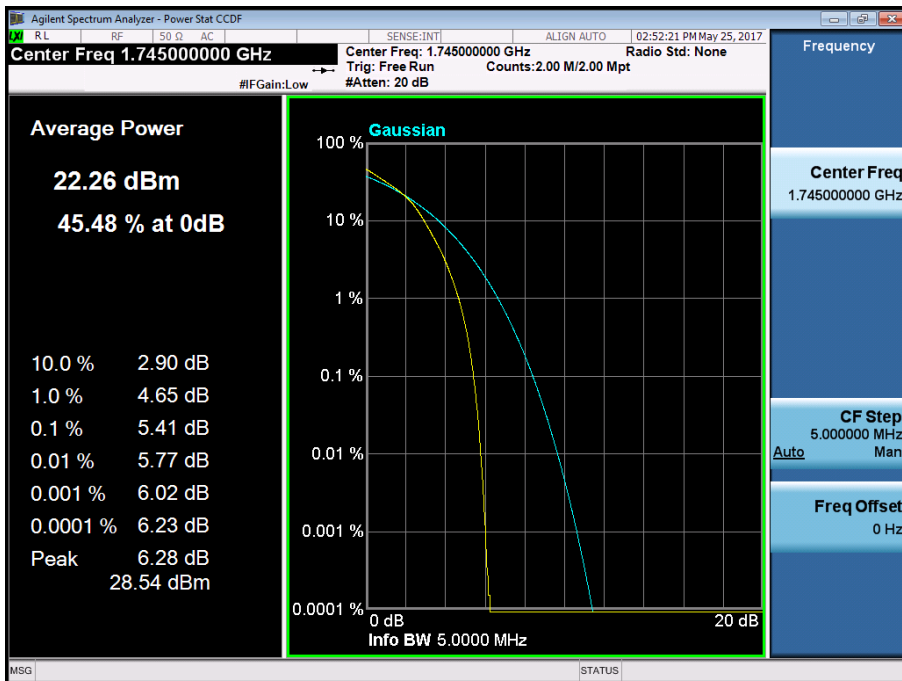

BAND 66. PAR Plot (10M BW\_Ch.132322\_QPSK\_RB50\_0)

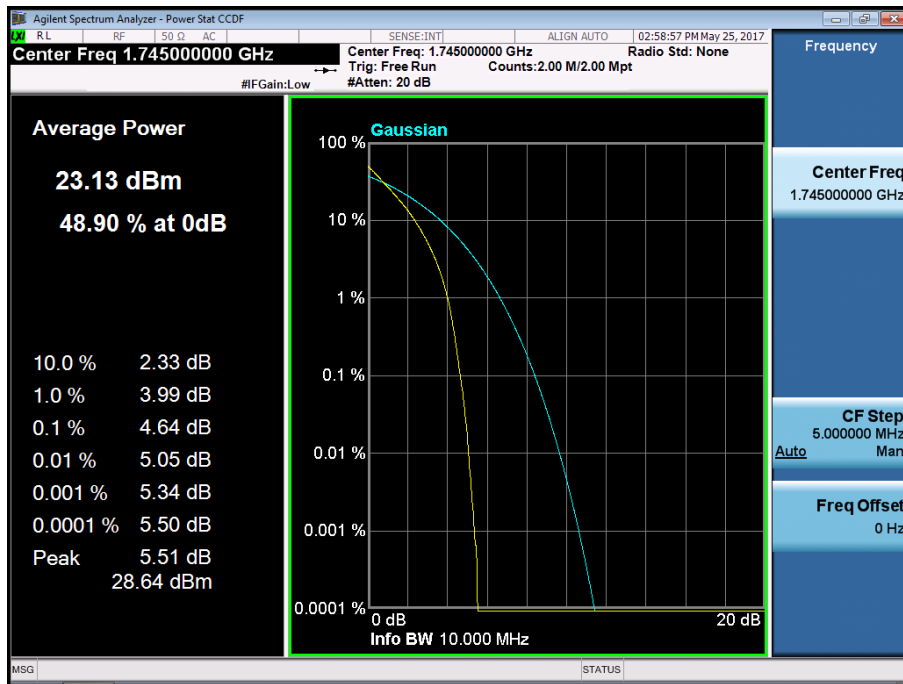

BAND 66. PAR Plot (10M BW\_Ch.132322\_16QAM\_RB50\_0)

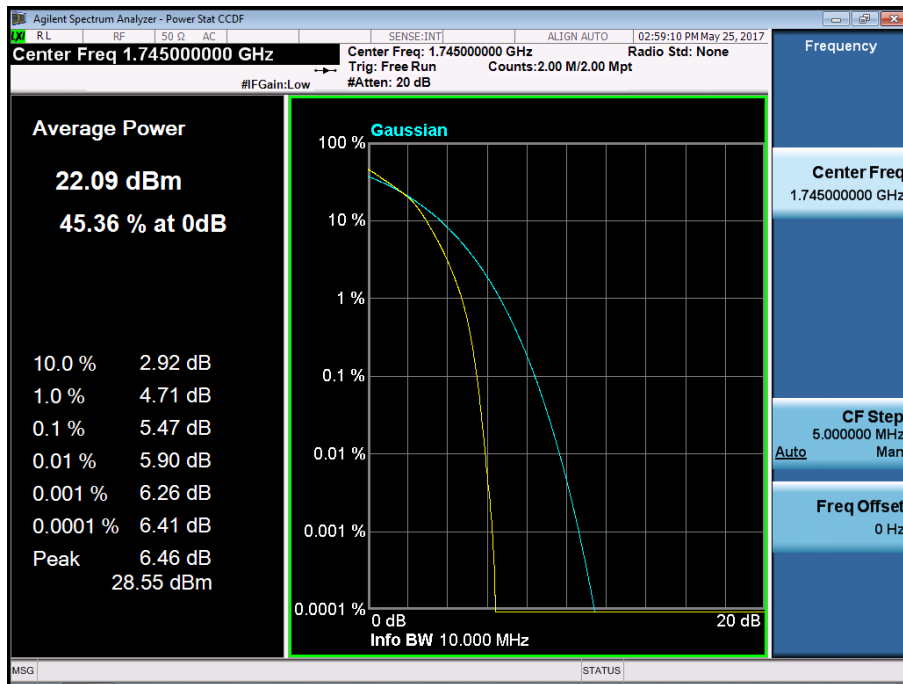

BAND 66. PAR Plot (15M BW\_Ch.132322\_QPSK\_RB75\_0)

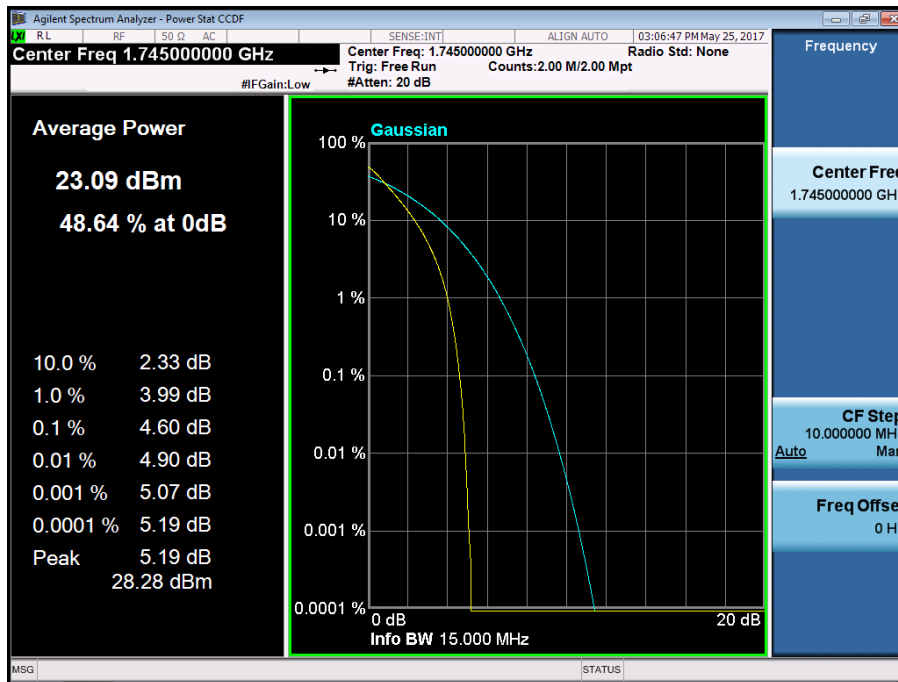

BAND 66. PAR Plot (15M BW\_Ch.132322\_16QAM\_RB75\_0)

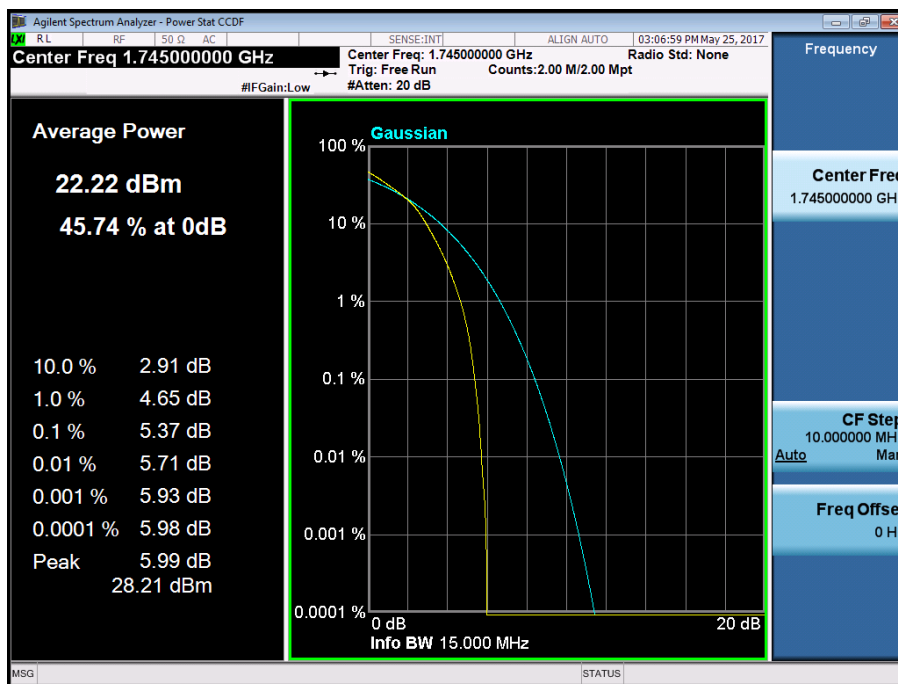

BAND 66. PAR Plot (20M BW\_Ch.132322\_QPSK\_RB100\_0)

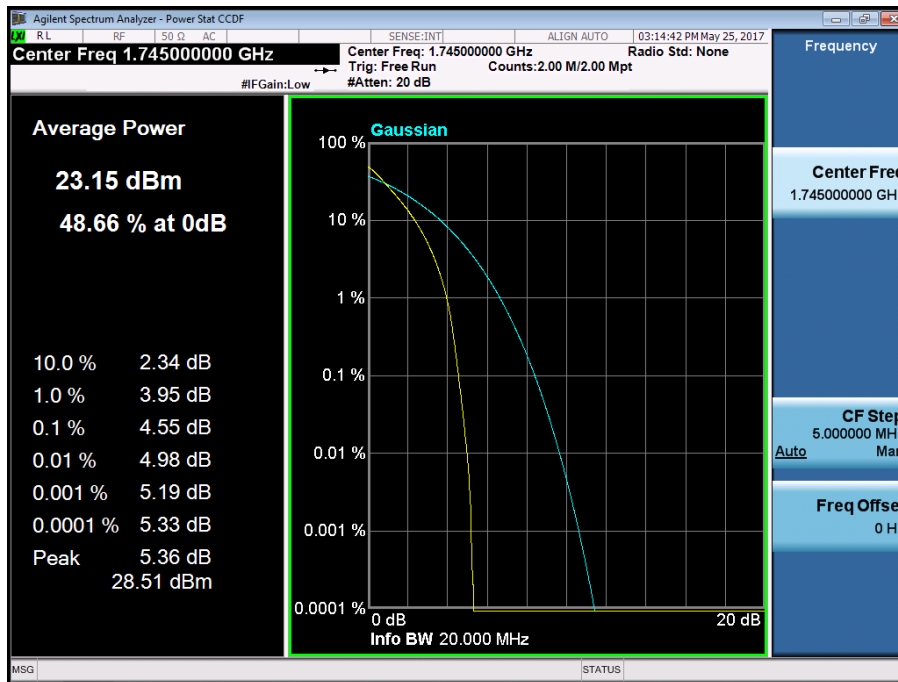

BAND 66. PAR Plot (20M BW\_Ch.132322\_16QAM\_RB100\_0)

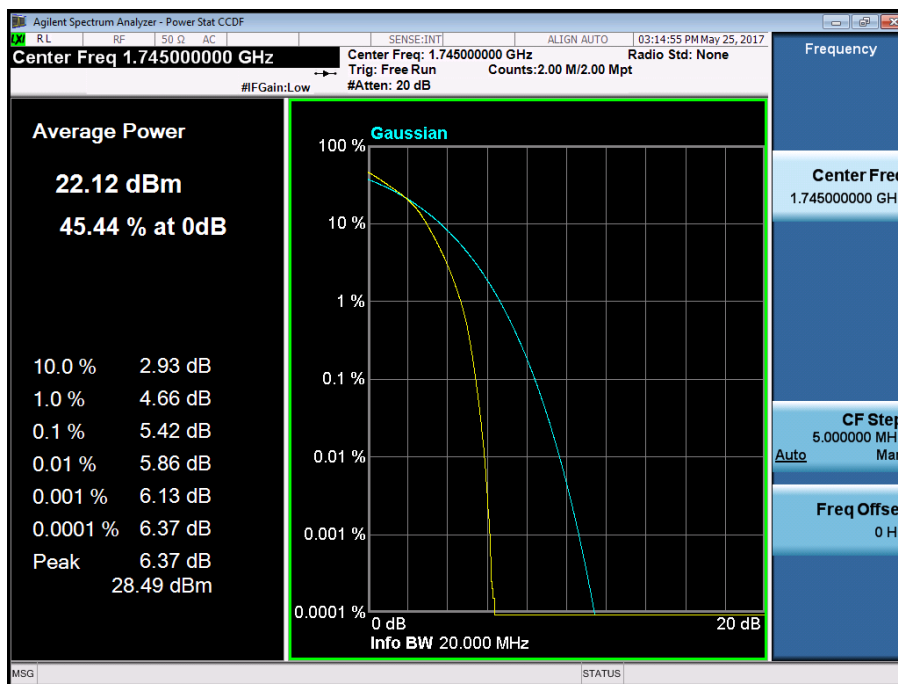

BAND 66. Lower Band Edge Plot (1.4M BW Ch.131979 QPSK RB 1, Offset 0) -1

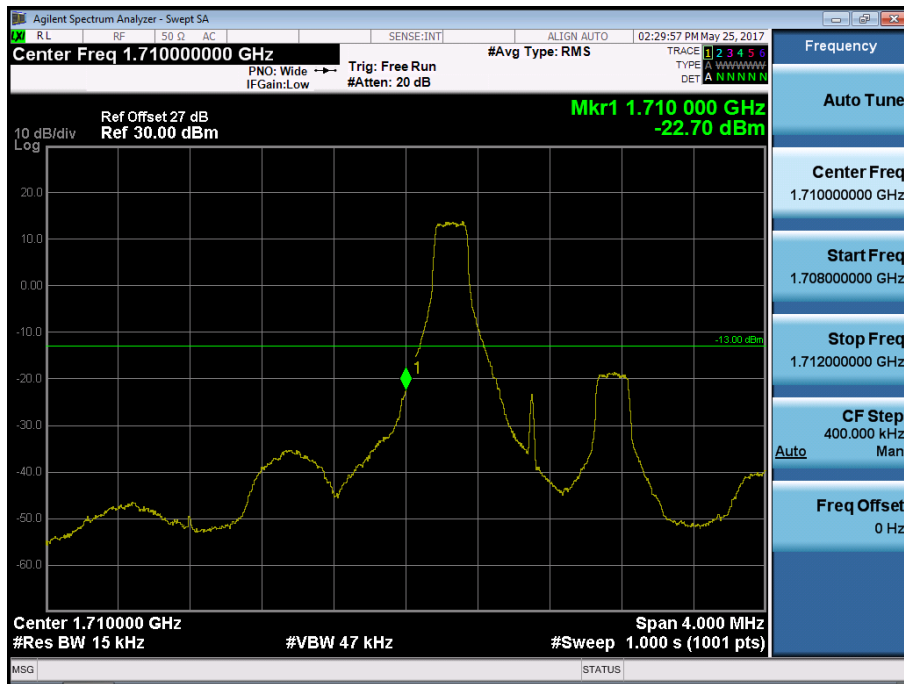

BAND 66. Lower Band Edge Plot (1.4M BW Ch. 131979 QPSK RB 6) -2

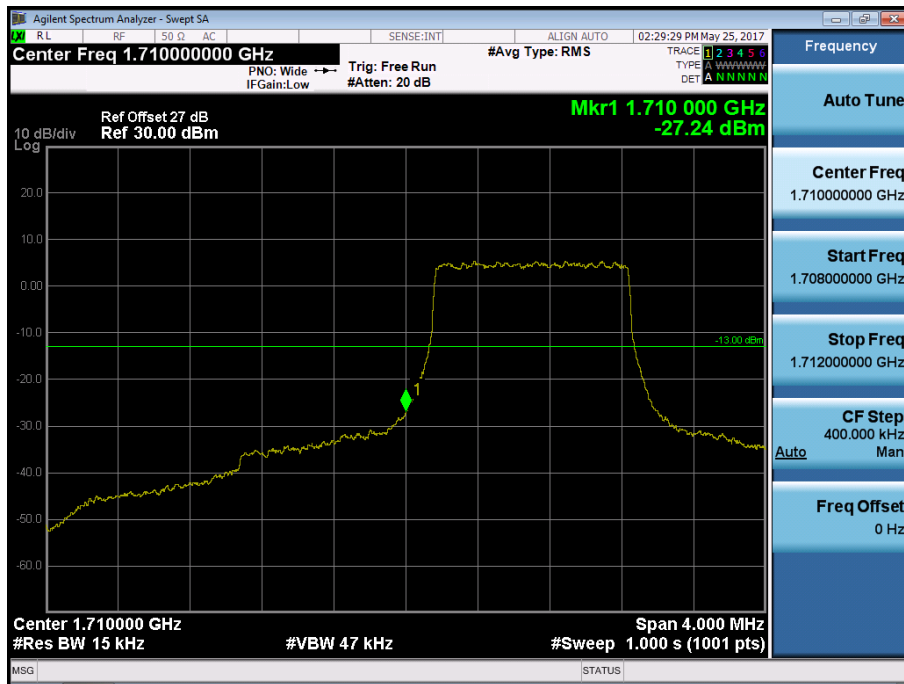

BAND 66. Lower Extended Band Edge Plot (1.4M BW Ch. 131979 QPSK\_RB6\_0) -3

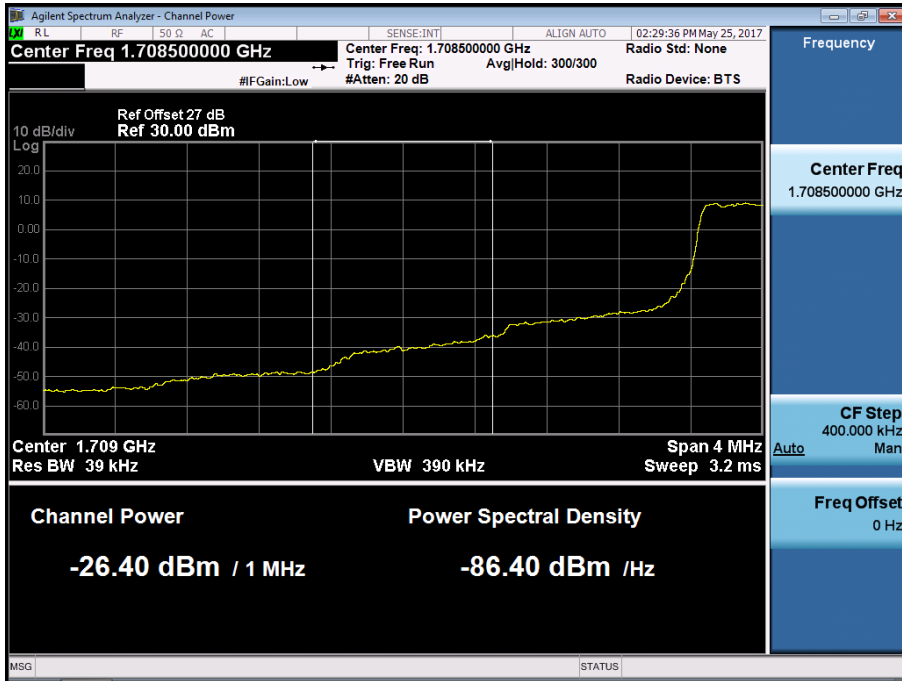

BAND 66. Lower Band Edge Plot (3M BW Ch. 131987 QPSK RB 1, Offset 0) -1

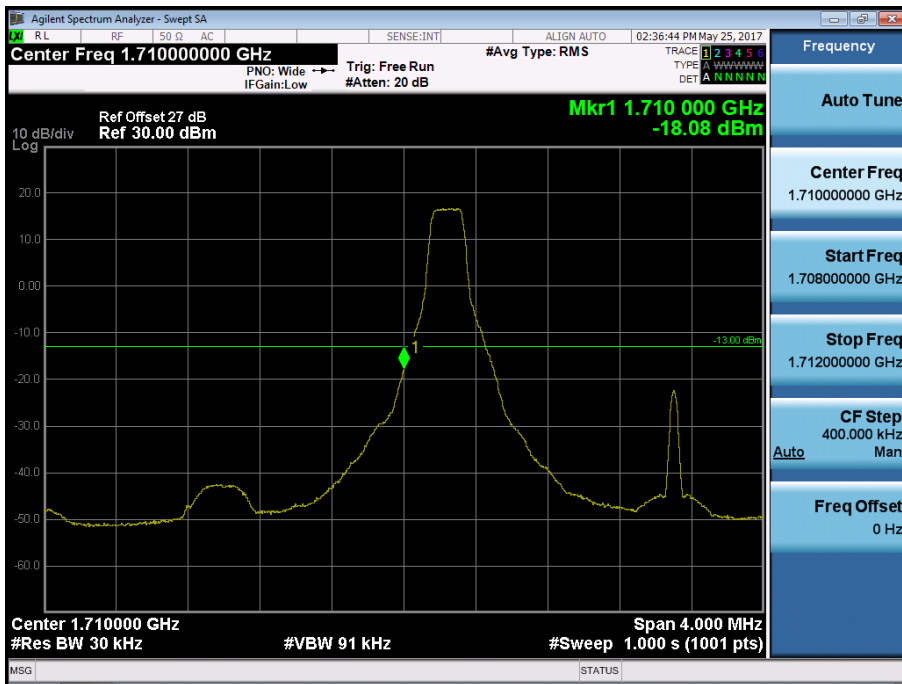

BAND 66. Lower Band Edge Plot (3M BW Ch. 131987 QPSK RB 15) -2

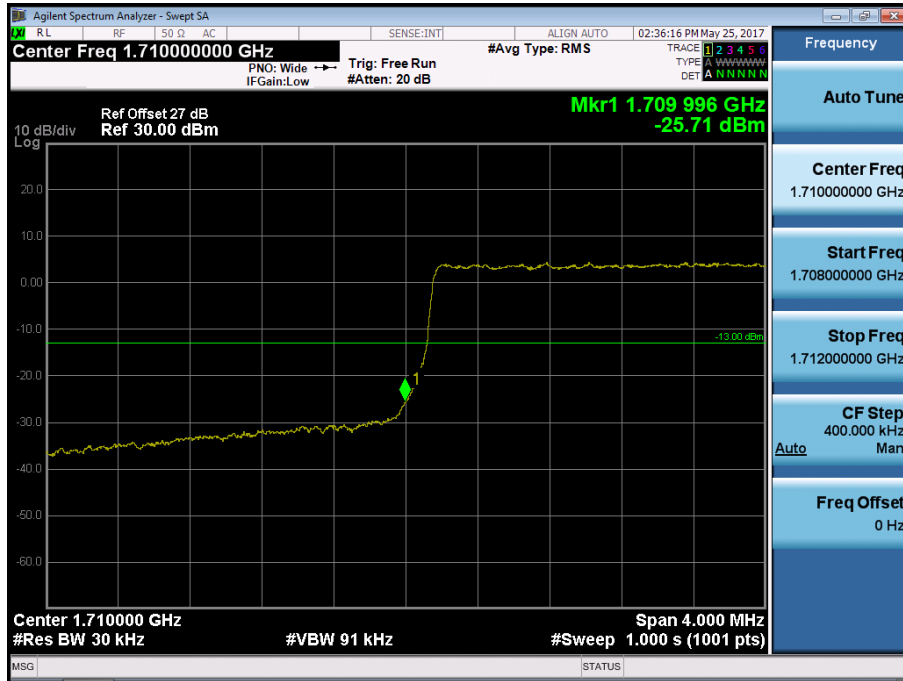

BAND 66. Lower Extended Band Edge Plot (3M BW Ch. 131987 QPSK\_RB15\_0) -3

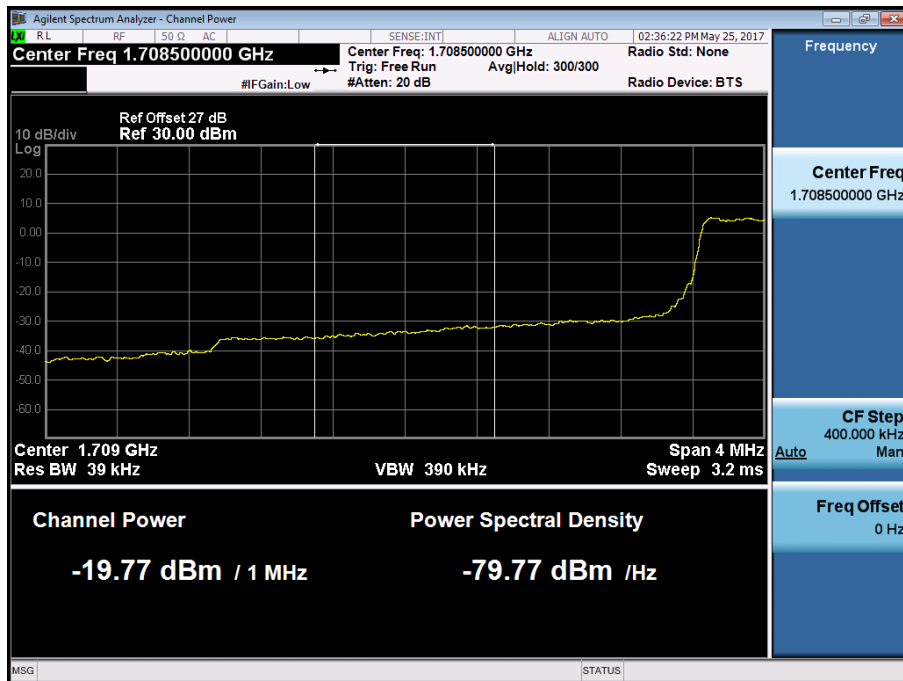

BAND 66. Lower Band Edge Plot (5M BW Ch. 131997 QPSK RB 1, Offset 0) -1

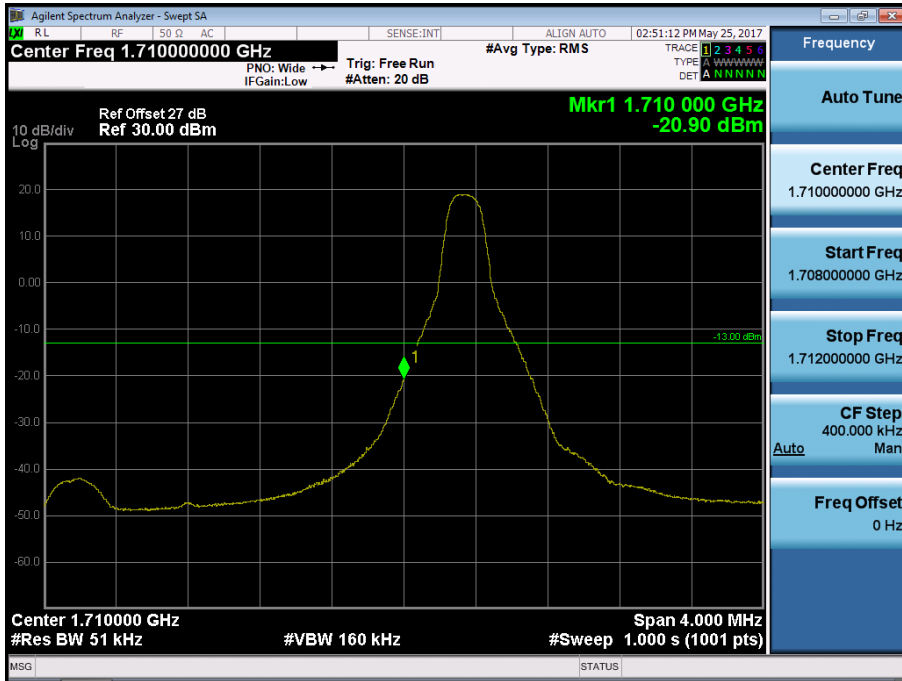

BAND 66. Lower Band Edge Plot (5M BW Ch. 131997 QPSK RB 25) -2

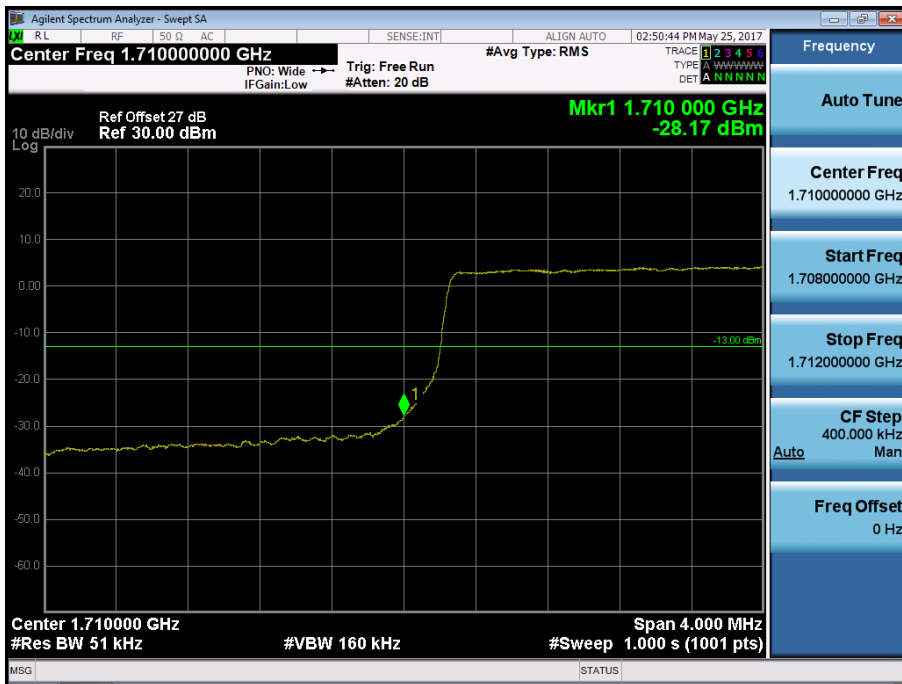



BAND 66. Lower Extended Band Edge Plot (5M BW Ch. 131997 QPSK\_RB25\_0) -3

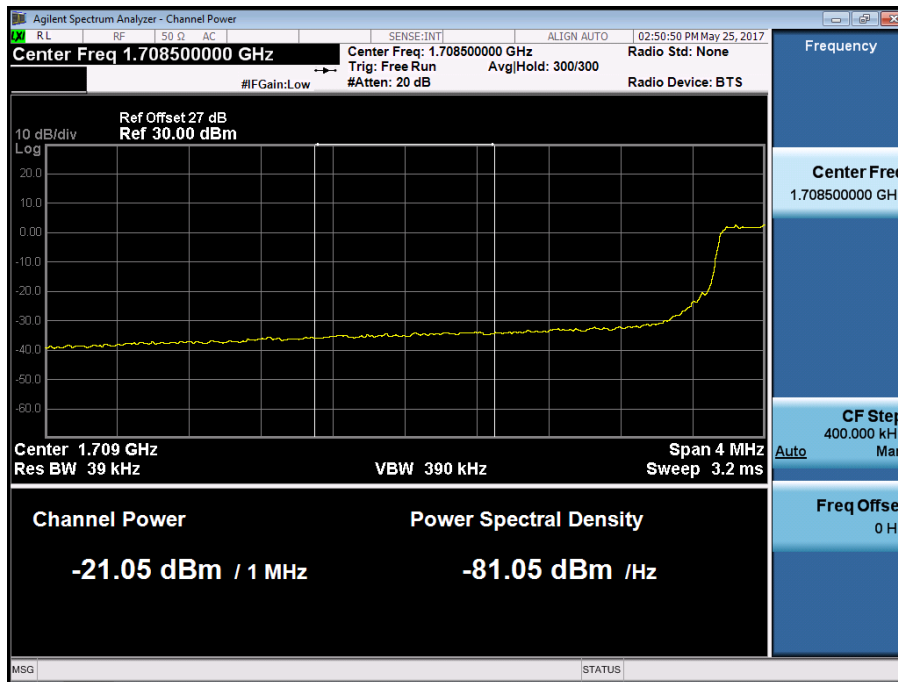

BAND 66. Lower Band Edge Plot (10M BW Ch. 132022 QPSK RB 1, Offset 0) -1

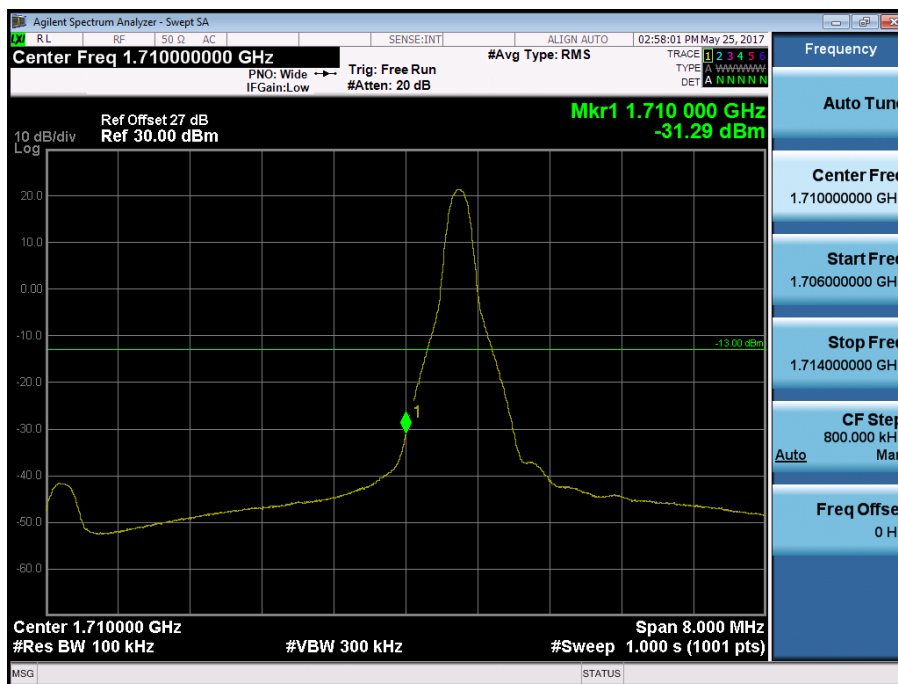

BAND 66. Lower Band Edge Plot (10M BW Ch. 132022 QPSK RB 50) -2

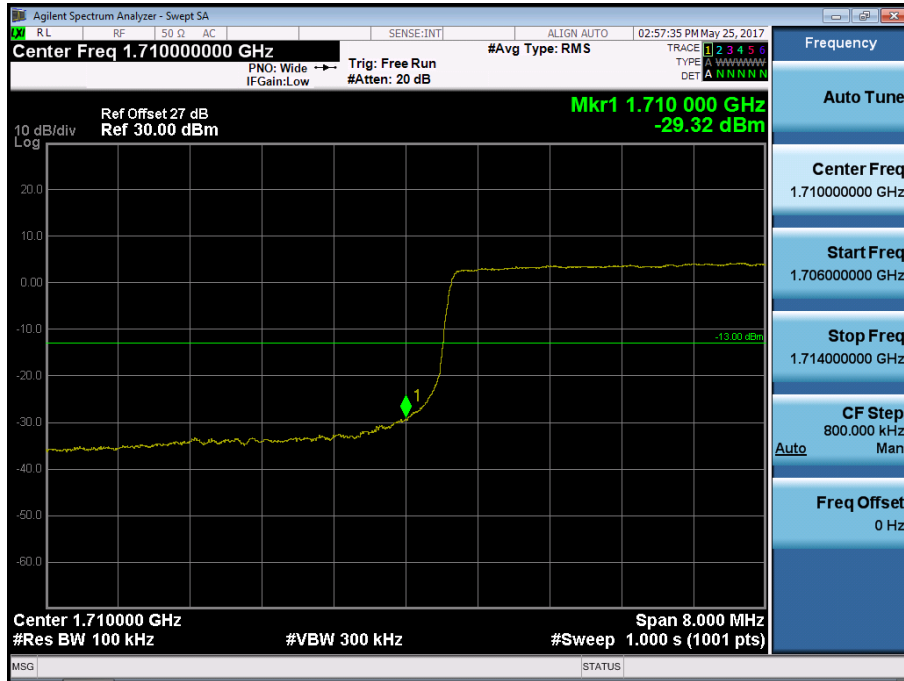

BAND 66. Lower Extended Band Edge Plot (10M BW Ch. 132022 QPSK\_RB50\_0) -3

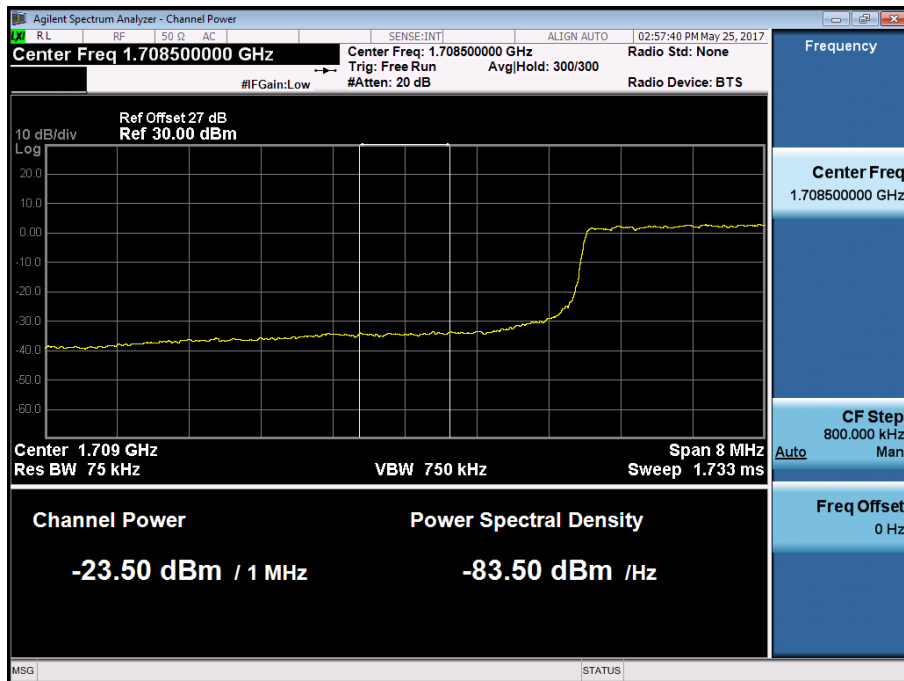

BAND 66. Lower Band Edge Plot (15M BW Ch. 132047 QPSK RB 1, Offset 0) -1

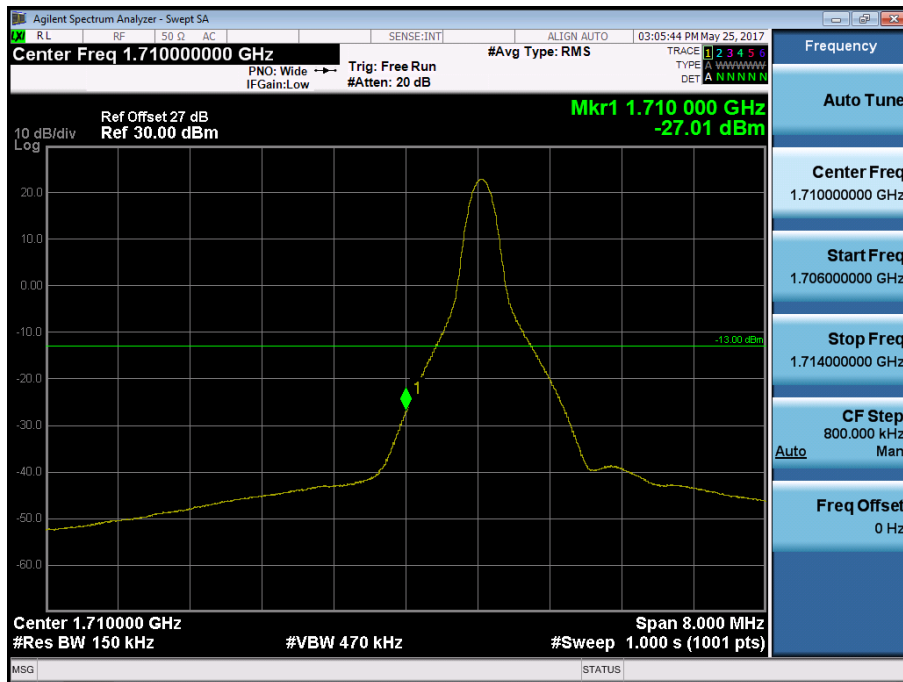

BAND 66. Lower Band Edge Plot (15M BW Ch. 132047 QPSK RB 75) -2

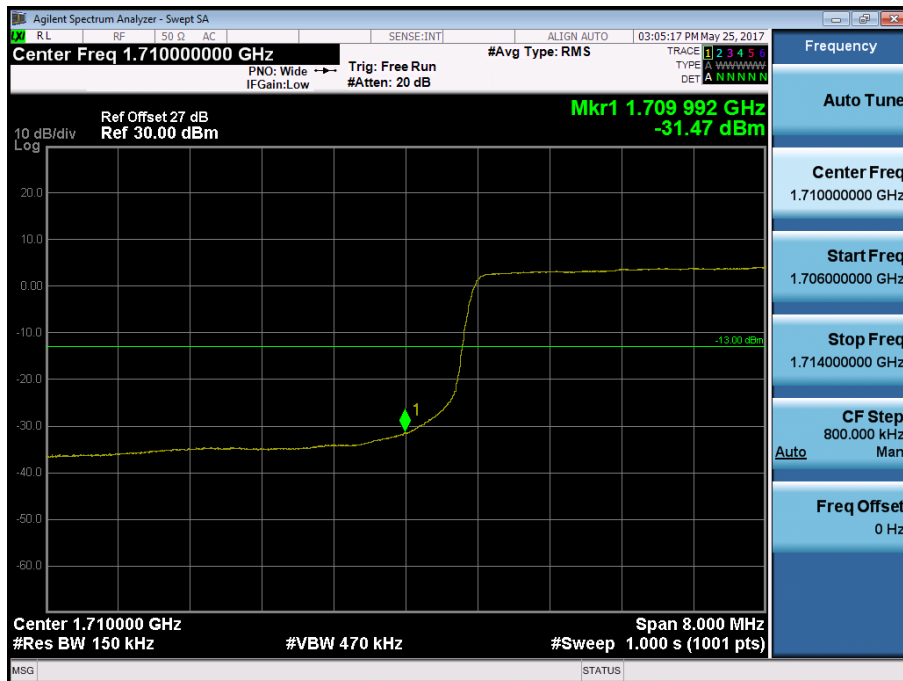

BAND 66. Lower Extended Band Edge Plot (15M BW Ch. 132047 QPSK\_RB75\_0) -3

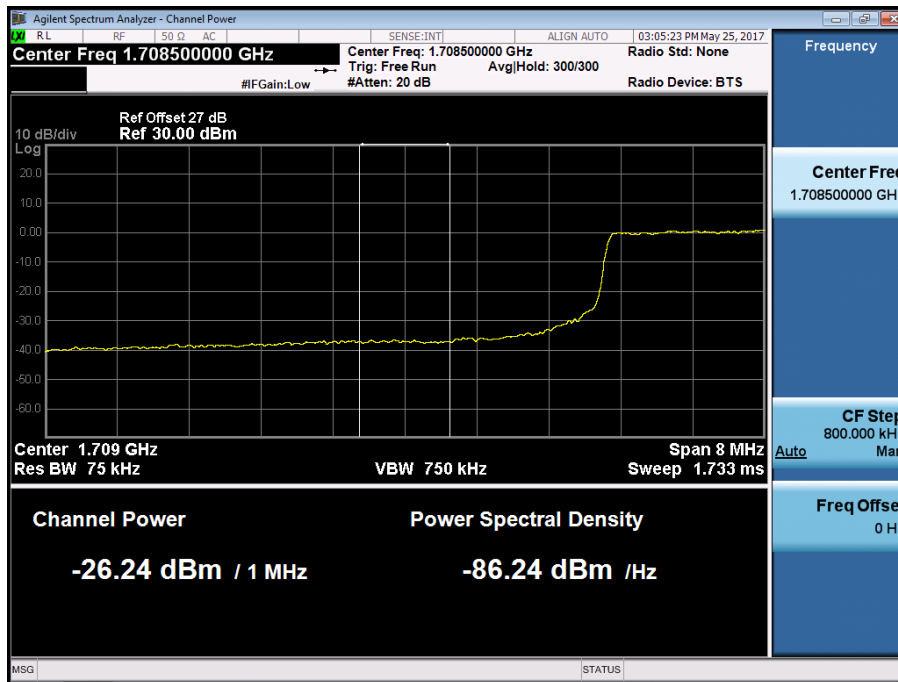

BAND 66. Lower Band Edge Plot (20M BW Ch. 132072 QPSK RB 1, Offset 0) -1

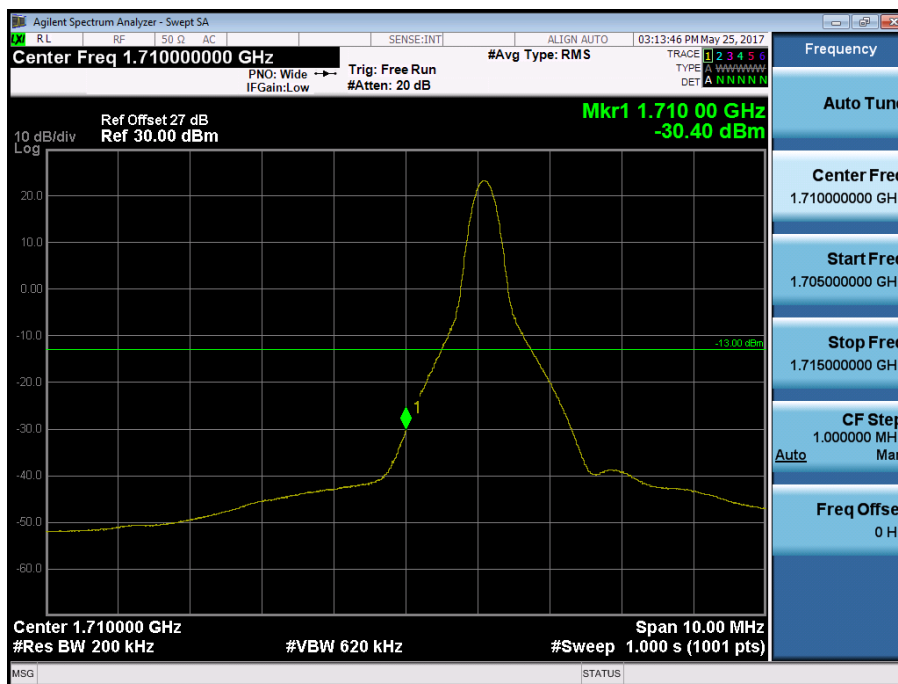

BAND 66. Lower Band Edge Plot (20M BW Ch. 132072 QPSK RB 100) -2

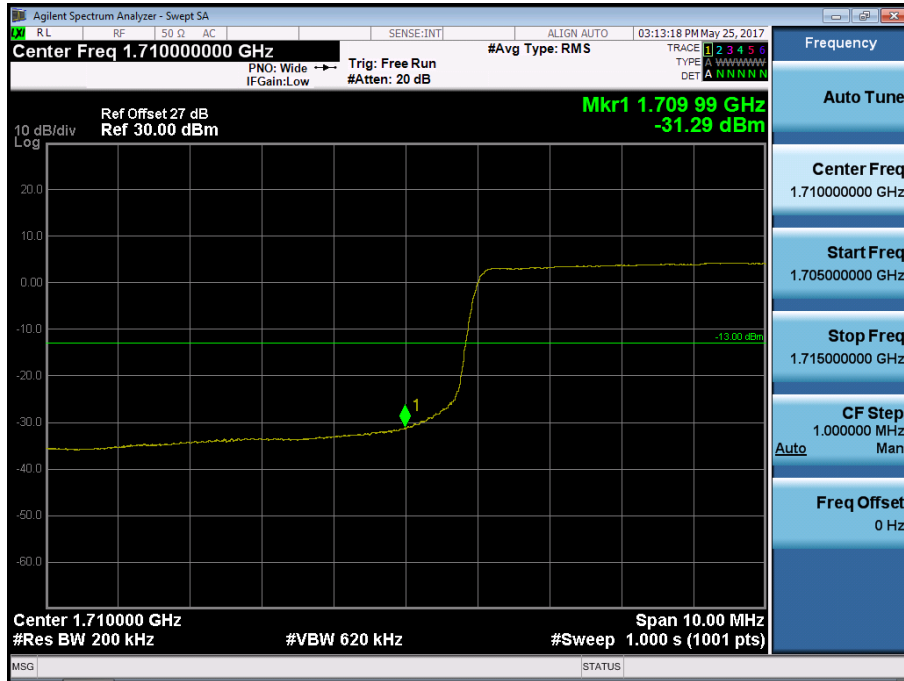

BAND 66. Lower Extended Band Edge Plot (20M BW Ch. 132072 QPSK\_RB100\_0) -3

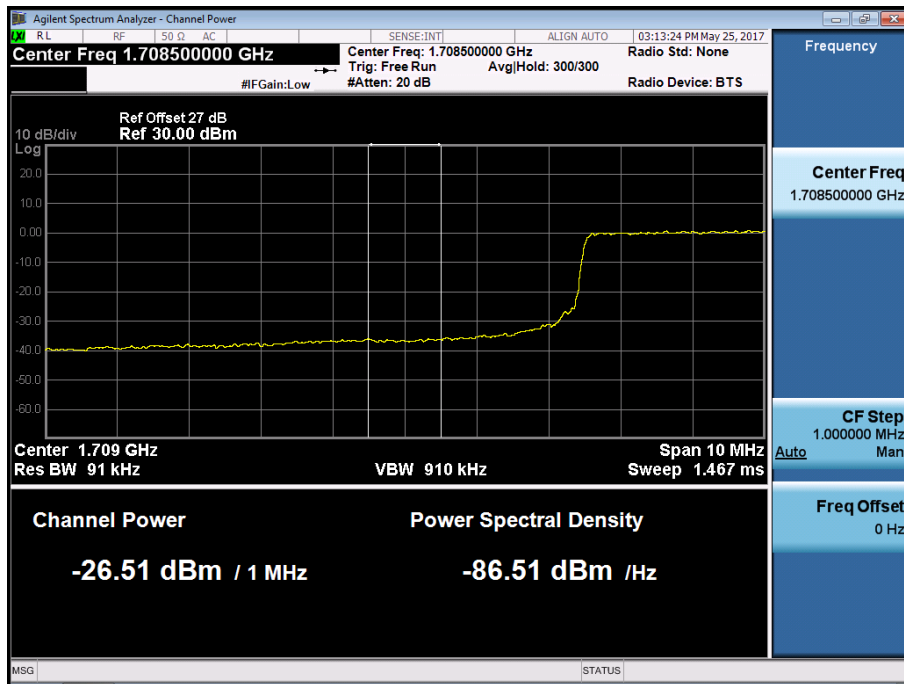

BAND 66. Upper Band Edge Plot (1.4M BW Ch. 132665 QPSK\_RB1\_Offset 5) -1

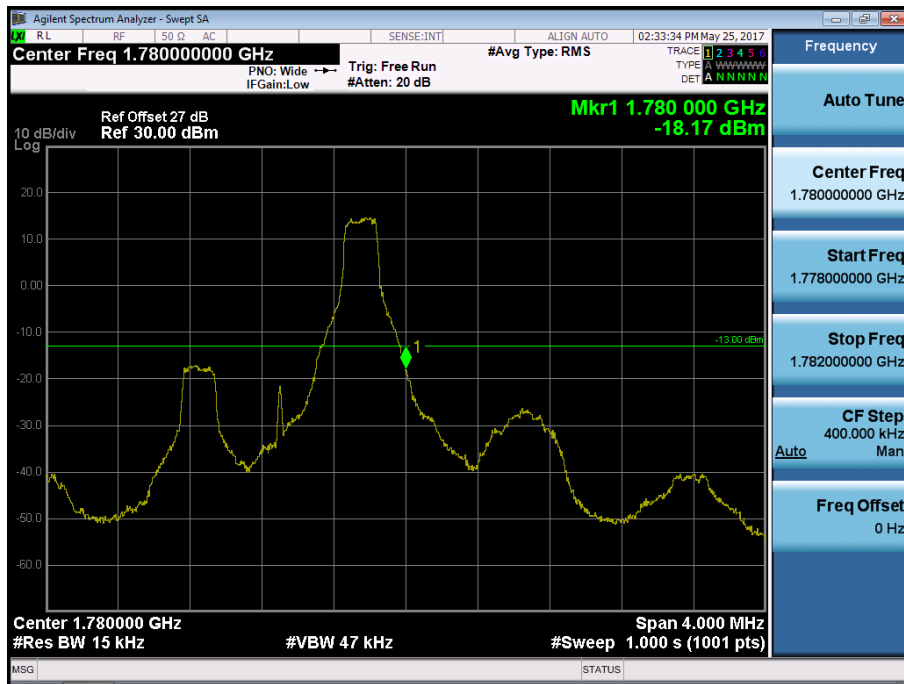

BAND 66. Upper Band Edge Plot (1.4M BW Ch. 132665 QPSK\_RB6) -2



BAND 66. Upper Extended Band Edge Plot (1.4M BW Ch. 132665 QPSK\_RB6\_0) -3

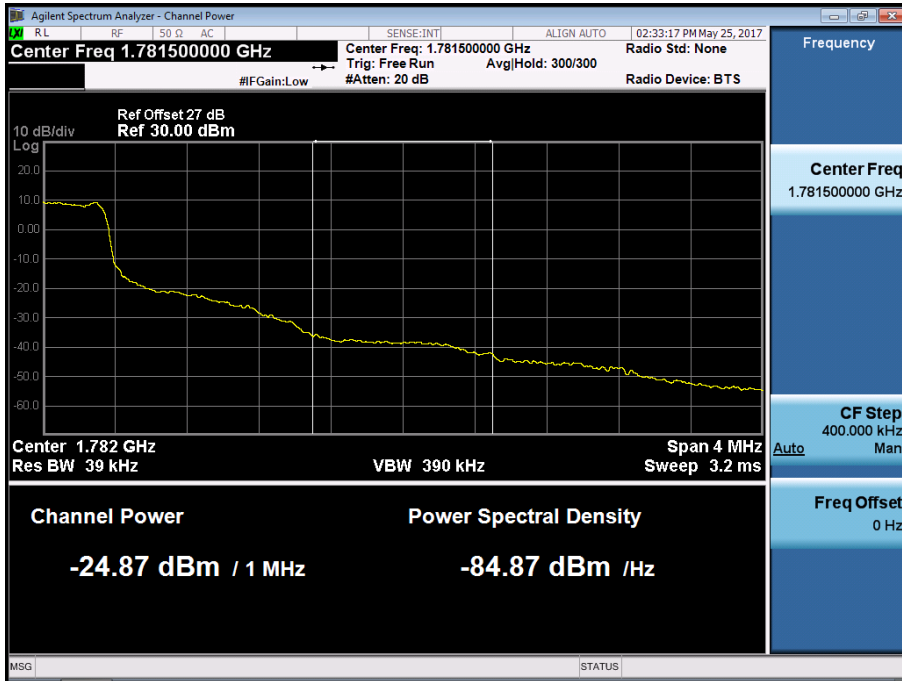

BAND 66. Upper Band Edge Plot (3M BW Ch. 132657 QPSK\_RB1\_Offset 14) -1

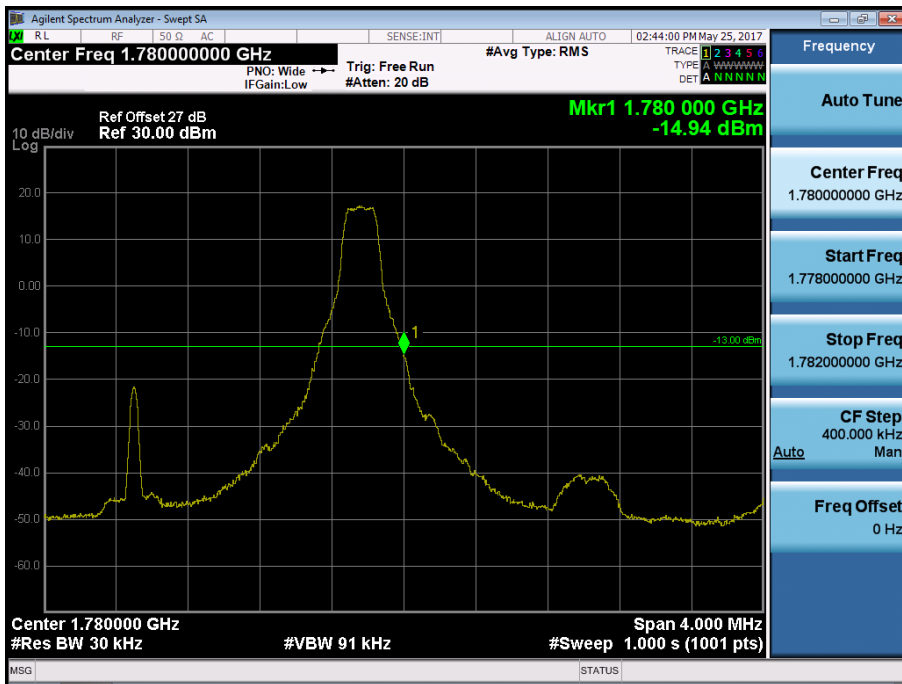

BAND 66. Upper Band Edge Plot (3M BW Ch. 132657 QPSK\_RB15) -2



BAND 66. Upper Extended Band Edge Plot (3M BW Ch. 132657 QPSK\_RB15\_0) -3

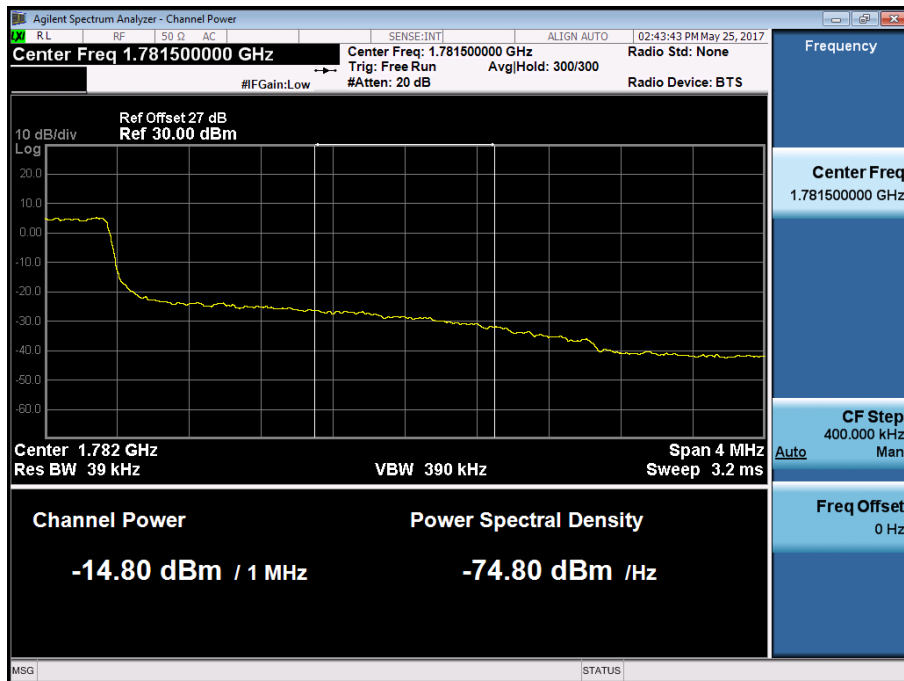



BAND 66. Upper Band Edge Plot (5M BW Ch. 132647 QPSK\_RB1\_Offset 24) -1

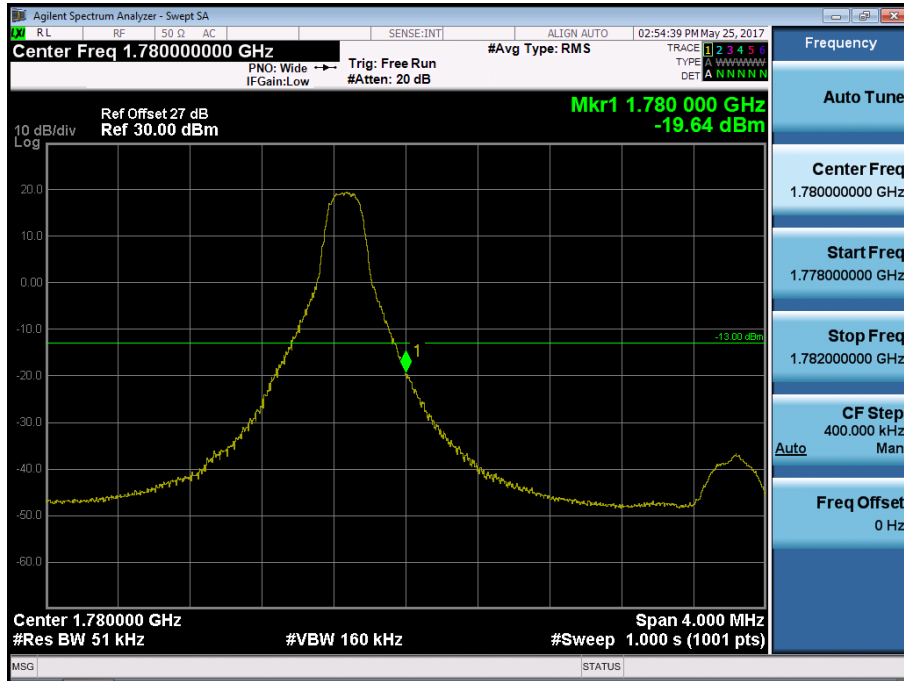

BAND 66. Upper Band Edge Plot (5M BW Ch. 132647 QPSK\_RB25) -2



BAND 66. Upper Extended Band Edge Plot (5M BW Ch. 132647 QPSK\_RB25) -3

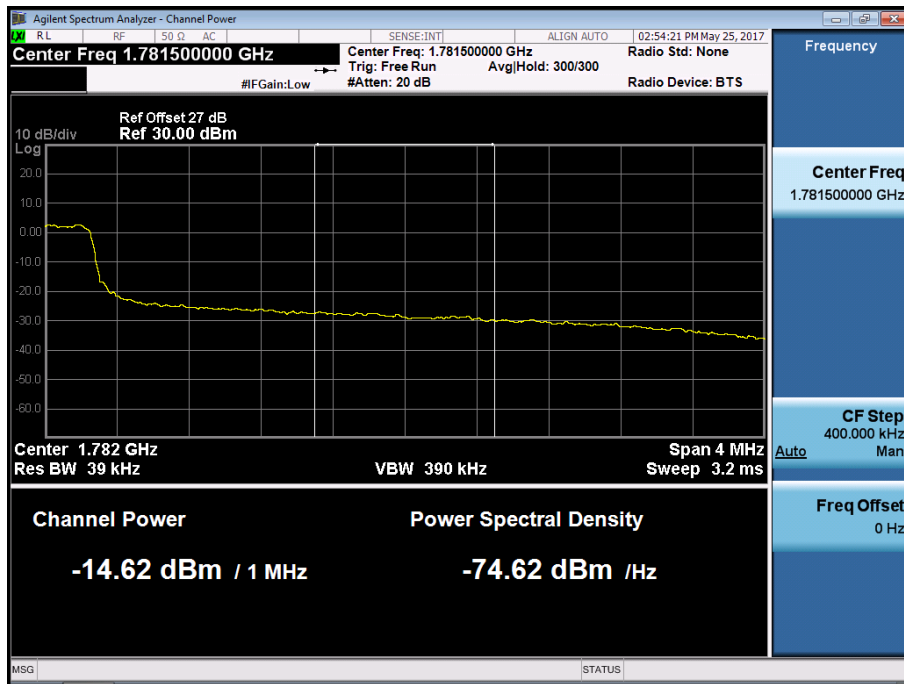

BAND 66. Upper Band Edge Plot (10M BW Ch. 132622 QPSK\_RB1\_Offset 49) -1

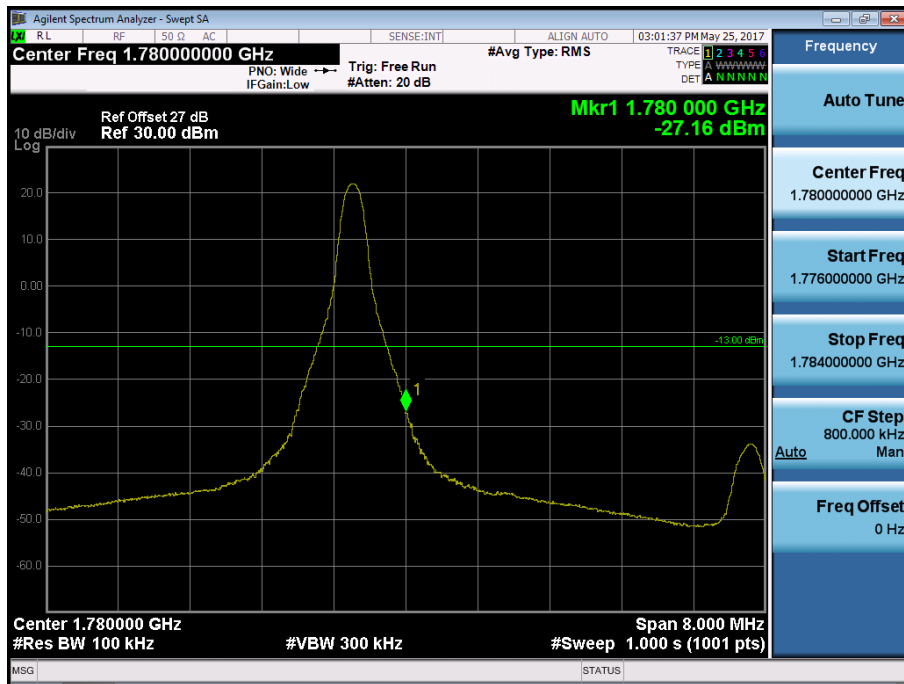

BAND 66. Upper Band Edge Plot (10M BW Ch. 132622 QPSK\_RB50) -2



BAND 66. Upper Extended Band Edge Plot (10M BW Ch. 132622 QPSK\_RB50) -3

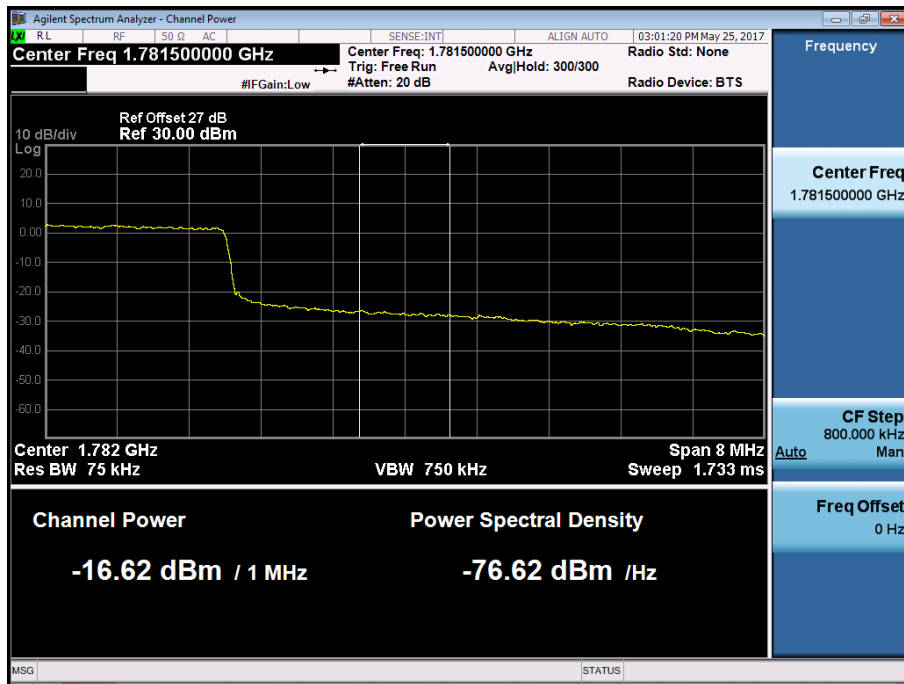

BAND 66. Upper Band Edge Plot (15M BW Ch. 132597 QPSK\_RB1\_Offset 74) -1

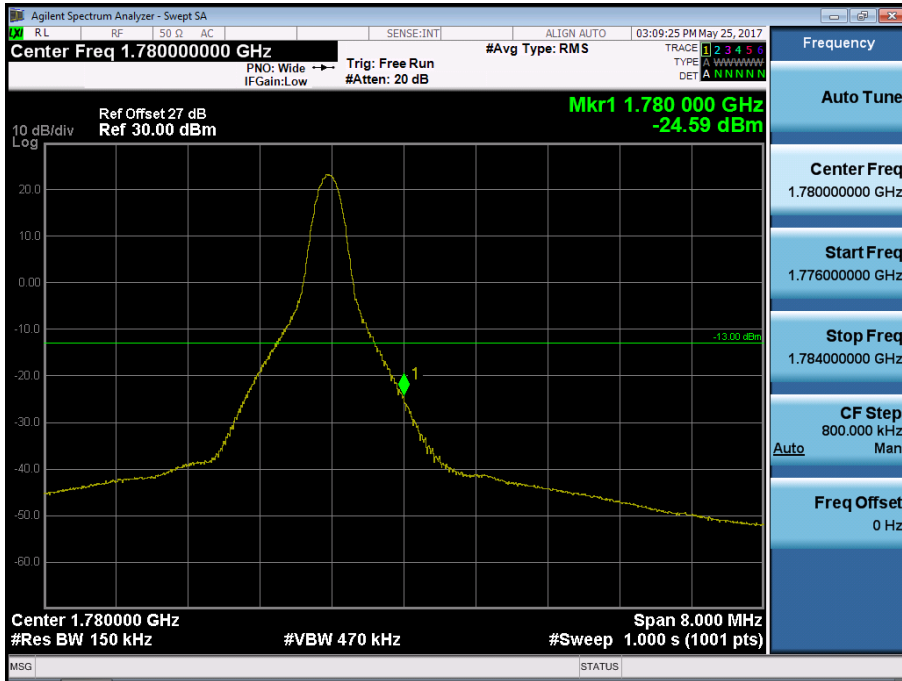

BAND 66. Upper Band Edge Plot (15M BW Ch. 132597 QPSK\_RB75) -2



BAND 66. Upper Extended Band Edge Plot (15M BW Ch. 132597 QPSK\_RB75) -3

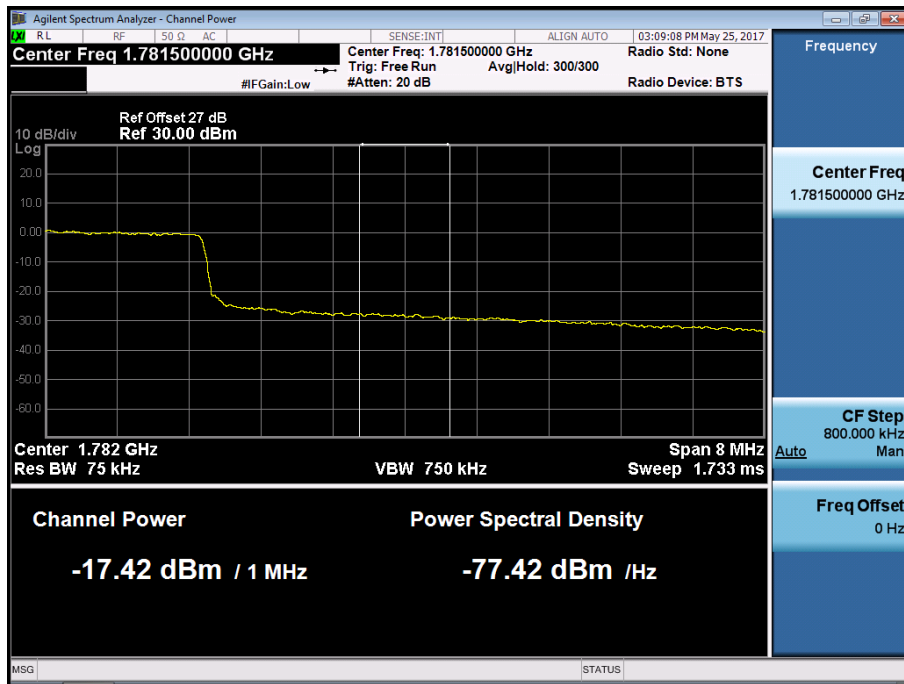

BAND 66. Upper Band Edge Plot (20M BW Ch. 132572 QPSK\_RB1\_Offset 99) -1

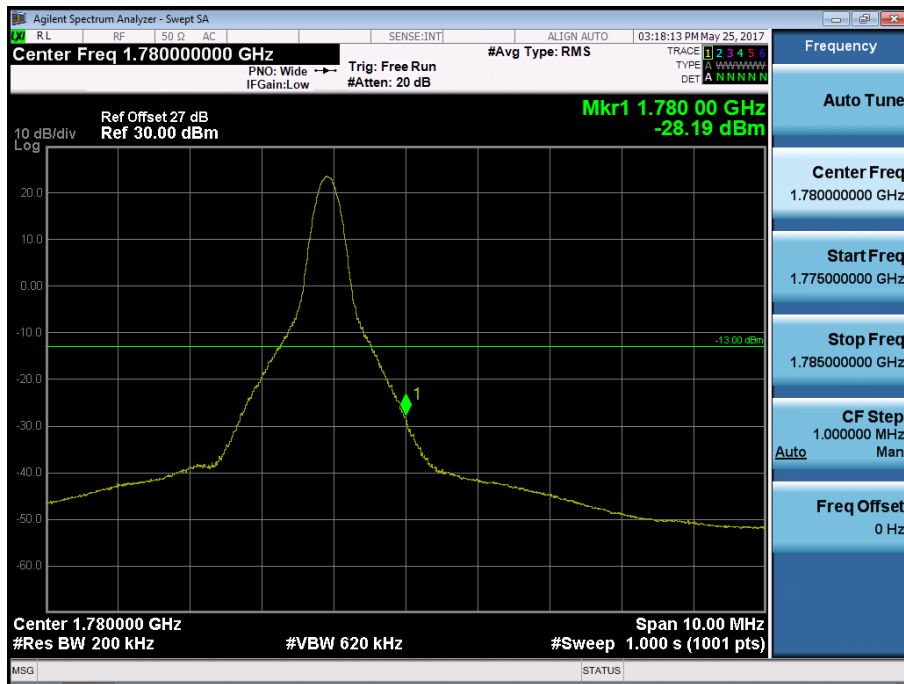

BAND 66. Upper Band Edge Plot (20M BW Ch. 132572 QPSK\_RB100) -2



BAND 66. Upper Extended Band Edge Plot (20M BW Ch. 132572 QPSK\_RB100) -3

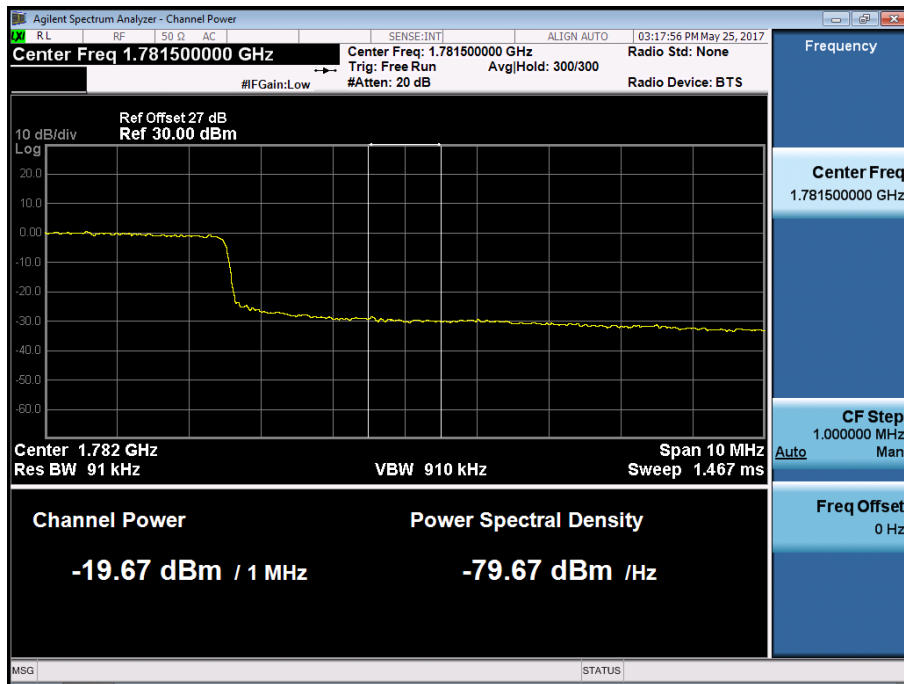

Band 13 Lower Band Edge Plot (5M BW Ch.23205 QPSK\_RB1 OFFSET0)

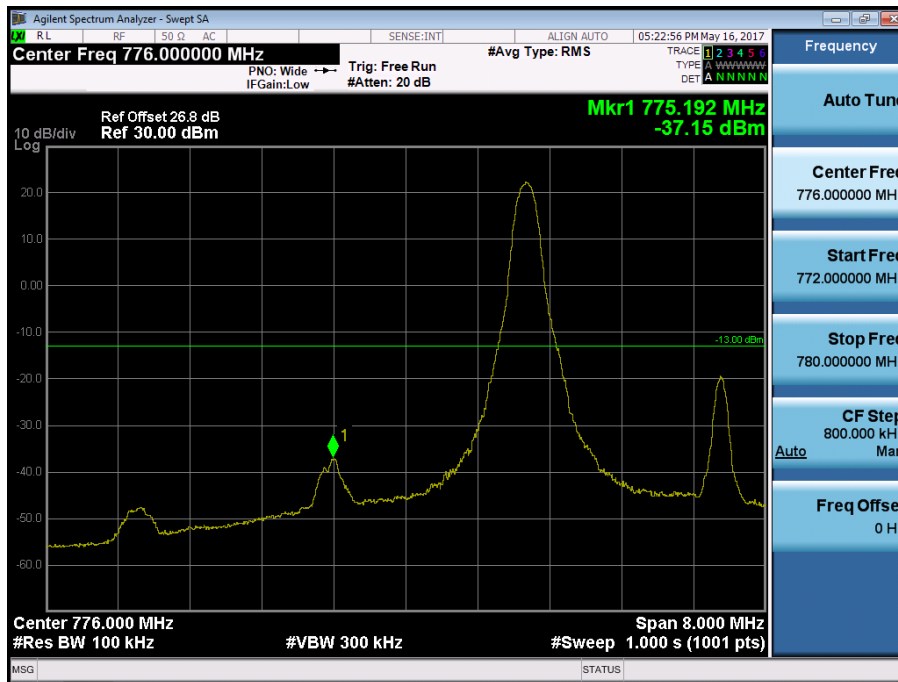

Band 13 Lower Band Edge Plot (5M BW Ch.23205 QPSK\_RB25)



Band 13 Lower Emission Mask (763 MHz ~ 775 MHz) Plot (5M BW Ch.23205 QPSK\_RB25\_0)

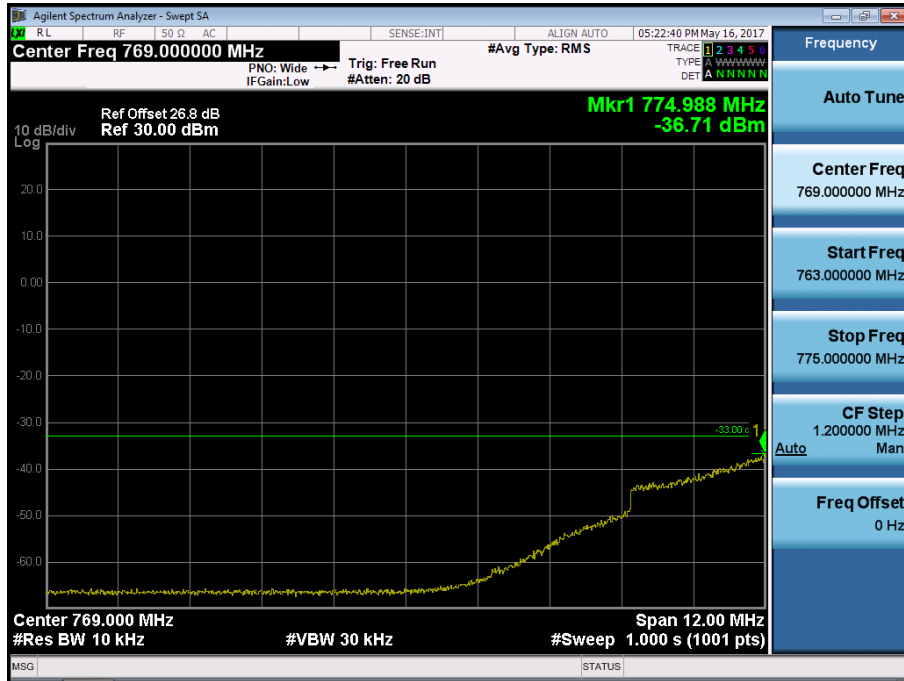

Band 13 Lower Band Edge Plot (10M BW Ch.23230 QPSK\_RB1 OFFSET0)

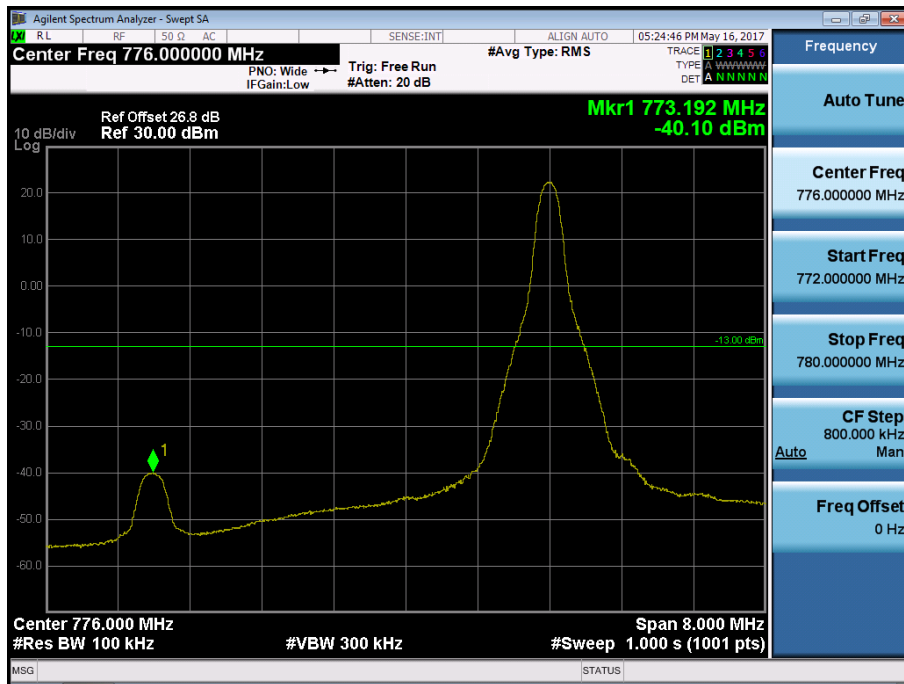



BAND 13. Lower & Upper Band Edge Plot (10M BW Ch.23230 QPSK RB 50)



Band 13 Lower Emission Mask (763 MHz ~ 775 MHz) Plot (10M BW Ch.23230 QPSK\_RB50\_0)

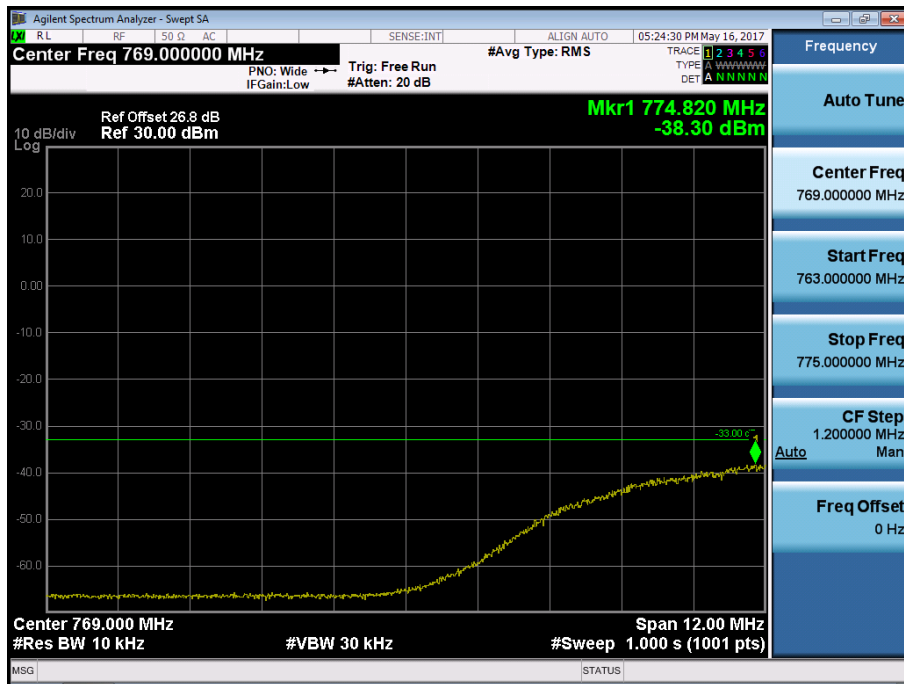

Band 13 Upper Band Edge Plot (5M BW Ch.23255 QPSK\_RB1\_Offset 24)

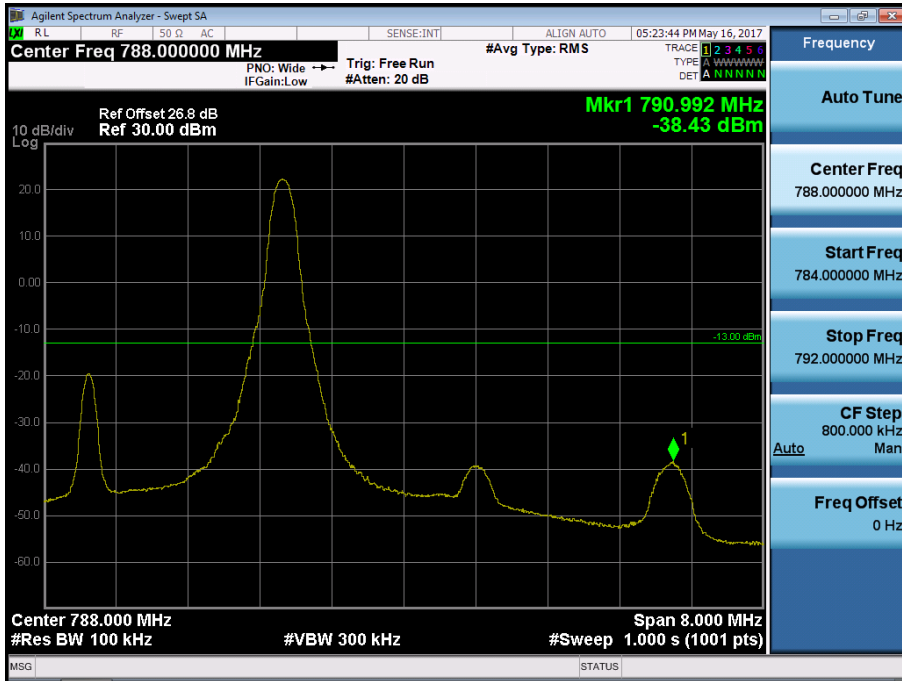

Band 13 Upper Band Edge Plot (5M BW Ch.23255 QPSK\_RB25)



Band 13 Upper Emission Mask (793 MHz ~805 MHz) Plot (5M BW Ch.23255 QPSK\_RB25\_0)



Band 13 Upper Band Edge Plot (10M BW Ch.23230 QPSK\_RB1\_Offset 49)

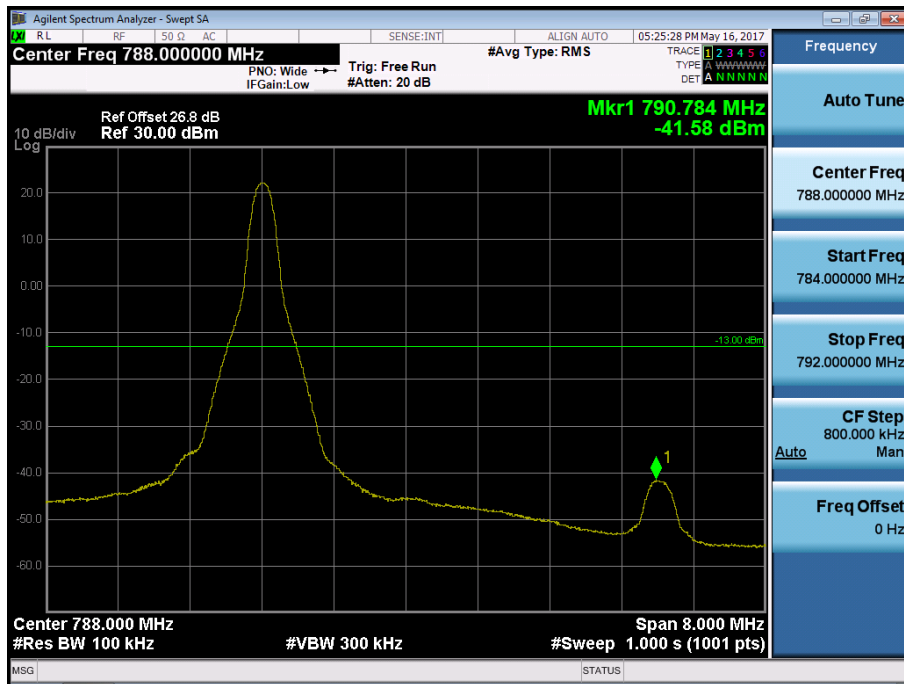

Band 13 Upper Band Edge Plot (10M BW Ch.23230 QPSK\_RB50)



Band 13 Upper Emission Mask (793 MHz ~805 MHz) Plot (10M BW Ch.23230 QPSK\_RB50\_0)







BAND 66. Conducted Spurious Plot\_1 (132665ch\_1.4MHz\_QPSK\_RB 1\_0)

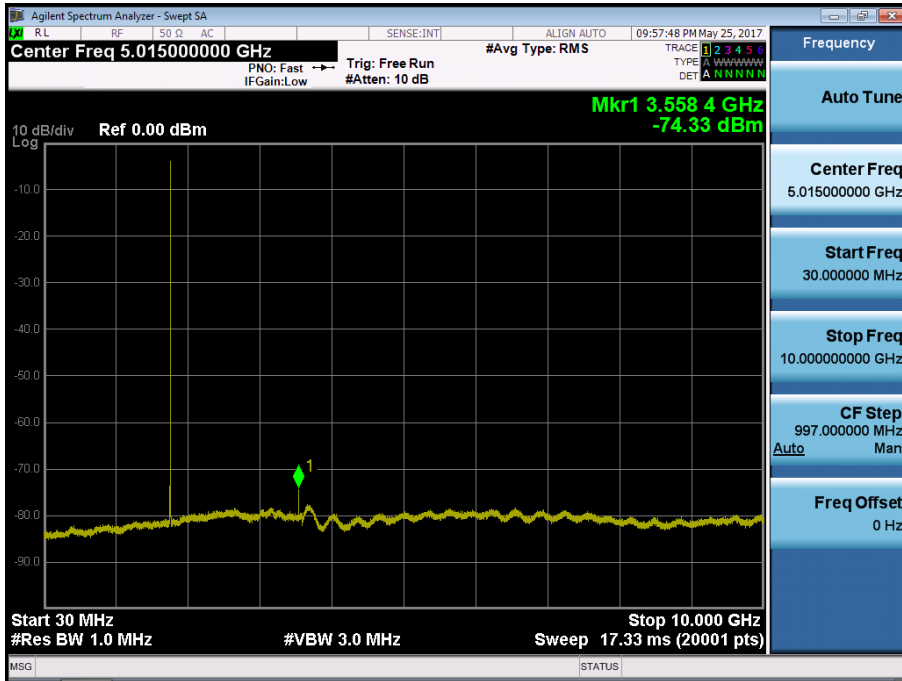

BAND 66. Conducted Spurious Plot\_2 (132665ch\_1.4MHz\_QPSK\_RB 1\_0)

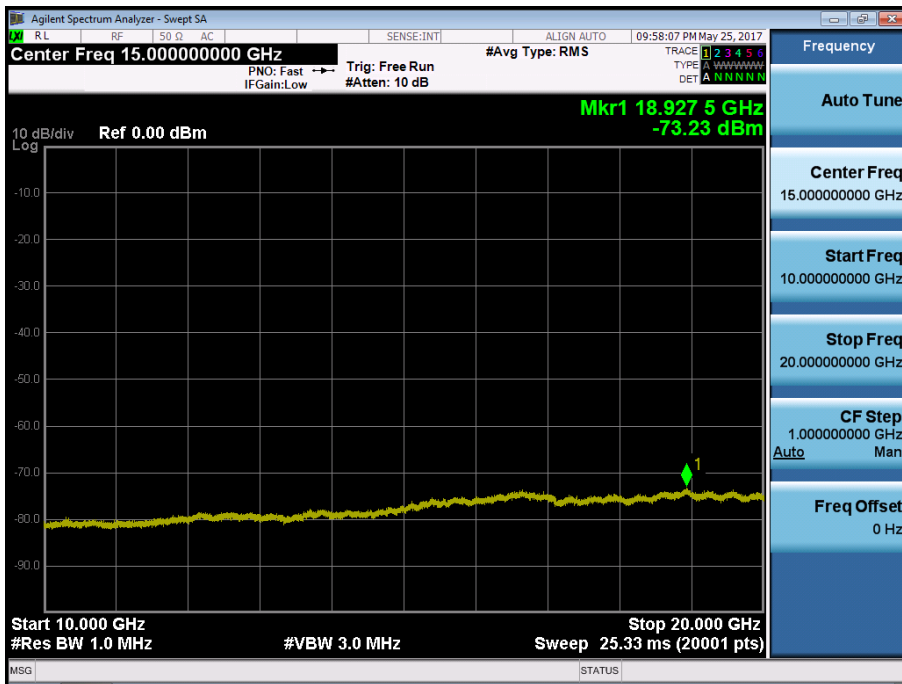

BAND 66. Conducted Spurious Plot\_1 (131987ch\_3MHz\_QPSK\_RB 1\_0)

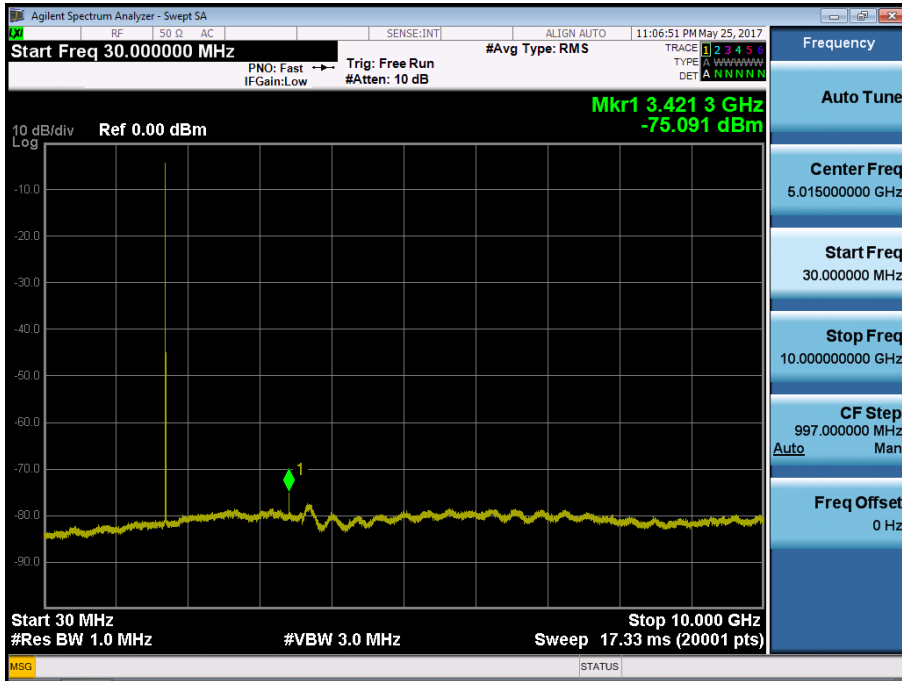

BAND 66. Conducted Spurious Plot\_2 (131987ch\_3MHz\_QPSK\_RB 1\_0)





BAND 66. Conducted Spurious Plot\_1 (132322ch\_3MHz\_QPSK\_RB 1\_0)

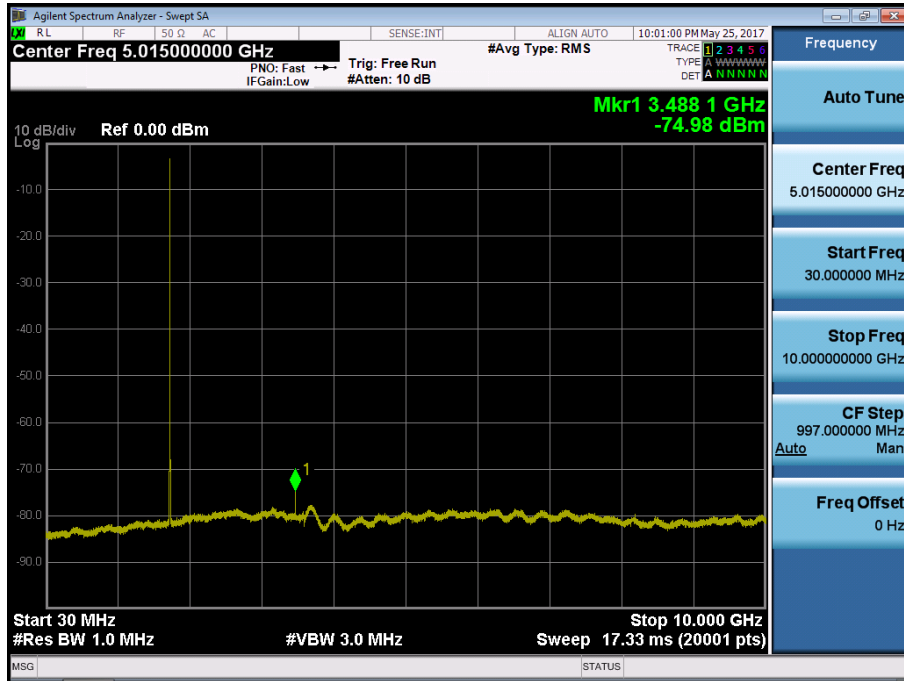

BAND 66. Conducted Spurious Plot\_2 (132322ch\_3MHz\_QPSK\_RB 1\_0)

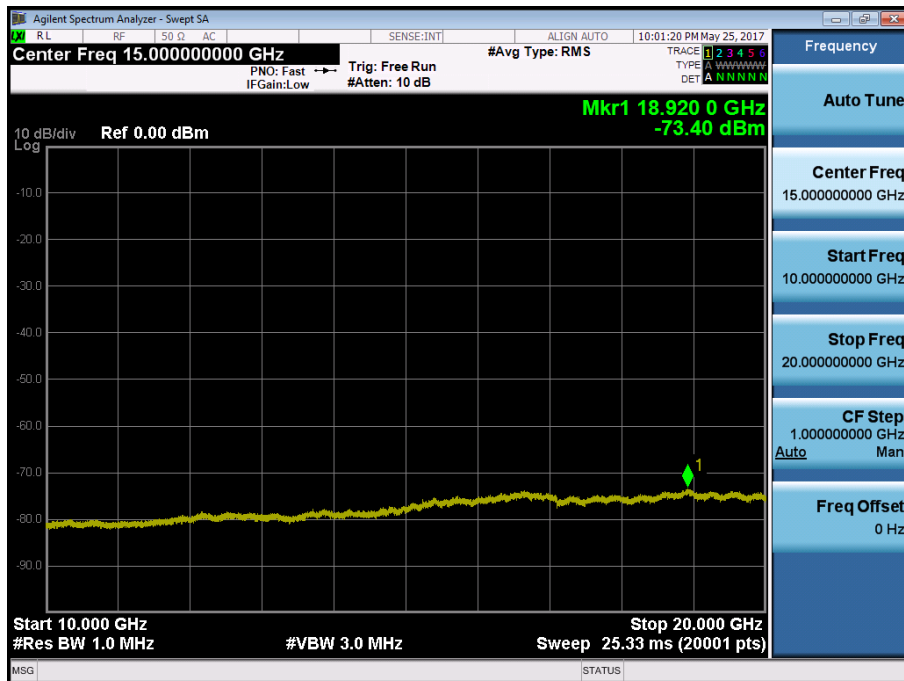

BAND 66. Conducted Spurious Plot\_1 (132657ch\_3MHz\_QPSK\_RB 1\_0)

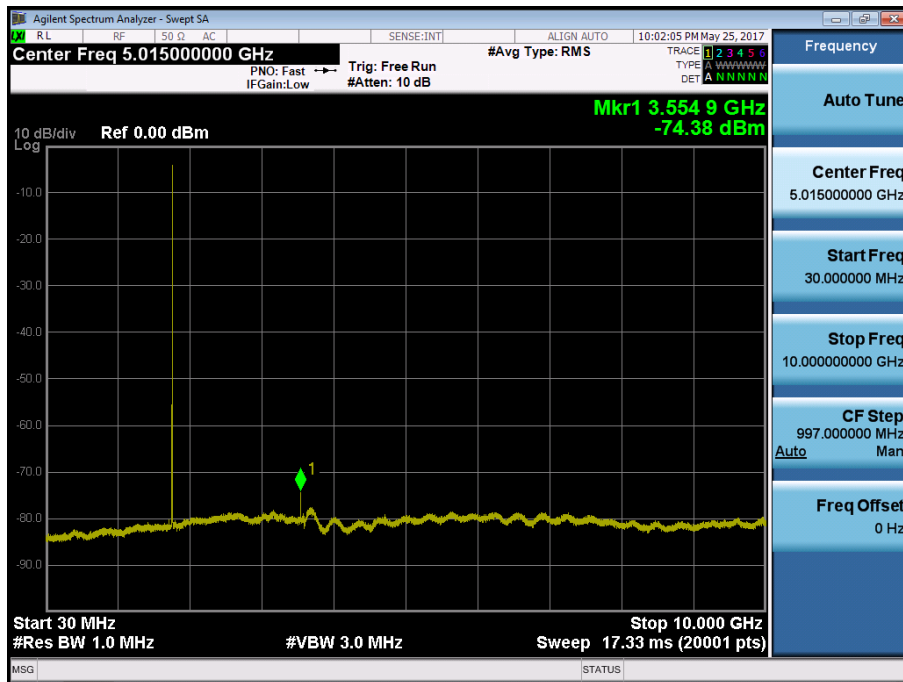

BAND 66. Conducted Spurious Plot\_2 (132657ch\_3MHz\_QPSK\_RB 1\_0)

