



PCTEST ENGINEERING LABORATORY, INC.

7185 Oakland Mills Road, Columbia, MD 21046 USA
Tel. 410.290.6652 / Fax 410.290.6654
<http://www.pctestlab.com>



MEASUREMENT REPORT FCC Part 22, 24, & 27 LTE

Applicant Name:
LG Electronics MobileComm U.S.A
1000 Sylvan Avenue
Englewood Cliffs, NJ 07632
United States

Date of Testing:
12/19/2016-1/10/17
Test Site/Location:
PCTEST Lab., Columbia, MD, USA
Test Report Serial No.:
1M1701030001-03.ZNF

FCC ID :	ZNFLS777
APPLICANT:	LG ELECTRONICS MOBILECOMM U.S.A



Application Type: Class II Permissive Change
FCC Classification: PCS Licensed Transmitter Held to Ear (PCE)
FCC Rule Part(s): §2; §22; §24; §27
Test Procedure(s): ANSI/TIA-603-D-2010, KDB 971168 D01 v02r02
EUT Type: Portable Handset
Model: LG-LS777
Additional Model(s): LGLS777, LS777
Test Device Serial No.: [S/N: 06783, 06841]
Class II Permissive Change: Please see FCC change document

This equipment has been shown to be capable of compliance with the applicable technical standards as indicated in the measurement report and was tested in accordance with the measurement procedures specified in §2.947. Test results reported herein relate only to the item(s) tested.

I attest to the accuracy of data. All measurements reported herein were performed by me or were made under my supervision and are correct to the best of my knowledge and belief. I assume full responsibility for the completeness of these measurements and vouch for the qualifications of all persons taking them.



 Randy Ortanez
 President



FCC ID: ZNFLS777		FCC Pt. 22, 24, & 27 LTE MEASUREMENT REPORT (CLASS II PERMISSIVE CHANGE)		Approved by: Quality Manager
Test Report S/N: 1M1701030001-03.ZNF	Test Dates: 12/19/2016-1/10/17	EUT Type: Portable Handset	Page 1 of 32	

T A B L E O F C O N T E N T S

FCC PART 22, 24, & 27 MEASUREMENT REPORT		3
1.0 INTRODUCTION		5
1.1 Scope.....		5
1.2 Testing Facility.....		5
2.0 PRODUCT INFORMATION.....		6
2.1 Equipment Description.....		6
2.2 Device Capabilities		6
2.3 Test Configuration.....		6
2.4 EMI Suppression Device(s)/Modifications.....		6
3.0 DESCRIPTION OF TESTS		7
3.1 Measurement Procedure.....		7
3.2 Block A Frequency Range		7
3.3 Cellular - Base Frequency Blocks		7
3.4 Cellular - Mobile Frequency Blocks.....		7
3.5 PCS - Base Frequency Blocks.....		8
3.6 PCS - Mobile Frequency Blocks		8
3.7 AWS - Base Frequency Blocks		8
3.8 AWS - Mobile Frequency Blocks.....		8
3.9 BRS/EBS Frequency Block.....		9
3.10 Radiated Power and Radiated Spurious Emissions.....		10
4.0 MEASUREMENT UNCERTAINTY		11
5.0 TEST EQUIPMENT CALIBRATION DATA		12
6.0 SAMPLE CALCULATIONS		13
7.0 TEST RESULTS.....		14
7.1 Summary.....		14
7.2 Radiated Power (ERP/EIRP)		15
7.3 Radiated Spurious Emissions Measurements.....		22
8.0 CONCLUSION.....		32

FCC ID: ZNFLS777		FCC Pt. 22, 24, & 27 LTE MEASUREMENT REPORT (CLASS II PERMISSIVE CHANGE)		Approved by: Quality Manager
Test Report S/N: 1M1701030001-03.ZNF	Test Dates: 12/19/2016-1/10/17	EUT Type: Portable Handset	Page 2 of 32	

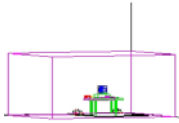

MEASUREMENT REPORT

FCC Part 22, 24, & 27



§2.1033 General Information



APPLICANT: LG Electronics MobileComm U.S.A
APPLICANT ADDRESS: 1000 Sylvan Avenue
 Englewood Cliffs, NJ 07632, United States
TEST SITE: PCTEST ENGINEERING LABORATORY, INC.
TEST SITE ADDRESS: 7185 Oakland Mills Road, Columbia, MD 21045 USA
FCC RULE PART(S): §2; §22; §24; §27
BASE MODEL: LG-LS777
FCC ID: ZNFLS777
FCC CLASSIFICATION: PCS Licensed Transmitter Held to Ear (PCE)
FREQUENCY TOLERANCE: ±0.00025 % (2.5 ppm)
Test Device Serial No.: 06783, 06841 Production Pre-Production Engineering
DATE(S) OF TEST: 12/19/2016-1/10/17
TEST REPORT S/N: 1M1701030001-03.ZNF

Test Facility / Accreditations

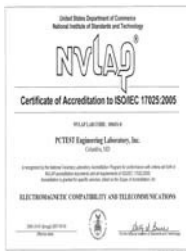
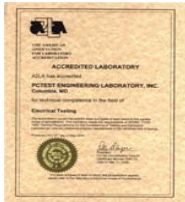
Measurements were performed at PCTEST Engineering Lab located in Columbia, MD 21046, U.S.A.



- PCTEST facility is an FCC registered (PCTEST Reg. No. 159966) test facility with the site description report on file and has met all the requirements specified in Section 2.948 of the FCC Rules and Industry Canada (2451B-1).
- PCTEST Lab is accredited to ISO 17025 by U.S. National Institute of Standards and Technology (NIST) under the National Voluntary Laboratory Accreditation Program (NVLAP Lab code: 100431-0) in EMC, FCC and Telecommunications.
- PCTEST Lab is accredited to ISO 17025-2005 by the American Association for Laboratory Accreditation (A2LA) in Specific Absorption Rate (SAR) testing, Hearing Aid Compatibility (HAC) testing, CTIA Test Plans, and wireless testing for FCC and Industry Canada Rules.
- PCTEST Lab is a recognized U.S. Conformity Assessment Body (CAB) in EMC and R&TTE (n.b. 0982) under the U.S.-EU Mutual Recognition Agreement (MRA).
- PCTEST TCB is a Telecommunication Certification Body (TCB) accredited to ISO/IEC Guide 65 by the American National Standards Institute (ANSI) in all scopes of FCC Rules and Industry Canada Standards (RSS).
- PCTEST facility is an IC registered (2451B-1) test laboratory with the site description on file at Industry Canada.
- PCTEST is a CTIA Authorized Test Laboratory (CATL) for AMPS, CDMA, and EvDO wireless devices and for Over-the-Air (OTA) Antenna Performance testing for AMPS, CDMA, GSM, GPRS, EGPRS, UMTS (W-CDMA), CDMA 1xEVDO, and CDMA 1xRTT.

FCC ID: ZNFLS777	 FCC Pt. 22, 24, & 27 LTE MEASUREMENT REPORT (CLASS II PERMISSIVE CHANGE)			Approved by: Quality Manager
Test Report S/N: 1M1701030001-03.ZNF	Test Dates: 12/19/2016-1/10/17	EUT Type: Portable Handset	Page 3 of 32	





MEASUREMENT REPORT

FCC Part 22, 24, & 27

Mode	FCC Rule Part	Tx Frequency (MHz)	ERP/EIRP		Modulation
			Max. Power (W)	Max. Power (dBm)	
LTE Band 12	27	699.7 - 715.3	0.056	17.46	QPSK
LTE Band 12	27	699.7 - 715.3	0.043	16.35	16QAM
LTE Band 12	27	700.5 - 714.5	0.064	18.04	QPSK
LTE Band 12	27	700.5 - 714.5	0.050	17.02	16QAM
LTE Band 12	27	701.5 - 713.5	0.079	18.97	QPSK
LTE Band 12	27	701.5 - 713.5	0.062	17.89	16QAM
LTE Band 12	27	704 - 711	0.082	19.16	QPSK
LTE Band 12	27	704 - 711	0.061	17.82	16QAM
LTE Band 5/26	22H	824.7 - 848.3	0.056	17.51	QPSK
LTE Band 5/26	22H	824.7 - 848.3	0.043	16.30	16QAM
LTE Band 5/26	22H	825.5 - 847.5	0.088	19.44	QPSK
LTE Band 5/26	22H	825.5 - 847.5	0.061	17.85	16QAM
LTE Band 5/26	22H	826.5 - 846.5	0.117	20.67	QPSK
LTE Band 5/26	22H	826.5 - 846.5	0.080	19.05	16QAM
LTE Band 5/26	22H	829 - 844	0.110	20.43	QPSK
LTE Band 5/26	22H	829 - 844	0.079	18.95	16QAM
LTE Band 5/26	22H	831.5 - 841.5	0.103	20.12	QPSK
LTE Band 5/26	22H	831.5 - 841.5	0.072	18.60	16QAM
LTE Band 4	27	1710.7 - 1754.3	0.210	23.23	QPSK
LTE Band 4	27	1710.7 - 1754.3	0.162	22.08	16QAM
LTE Band 4	27	1711.5 - 1753.5	0.244	23.88	QPSK
LTE Band 4	27	1711.5 - 1753.5	0.199	22.99	16QAM
LTE Band 4	27	1712.5 - 1752.5	0.272	24.34	QPSK
LTE Band 4	27	1712.5 - 1752.5	0.200	23.00	16QAM
LTE Band 4	27	1715 - 1750	0.282	24.51	QPSK
LTE Band 4	27	1715 - 1750	0.240	23.80	16QAM
LTE Band 4	27	1717.5 - 1747.5	0.317	25.01	QPSK
LTE Band 4	27	1717.5 - 1747.5	0.248	23.94	16QAM
LTE Band 4	27	1720 - 1745	0.257	24.10	QPSK
LTE Band 4	27	1720 - 1745	0.194	22.89	16QAM
LTE Band 2/25	24E	1850.7 - 1914.3	0.257	24.10	QPSK
LTE Band 2/25	24E	1850.7 - 1914.3	0.253	24.03	16QAM
LTE Band 2/25	24E	1851.5 - 1913.5	0.306	24.86	QPSK
LTE Band 2/25	24E	1851.5 - 1913.5	0.236	23.73	16QAM
LTE Band 2/25	24E	1852.5 - 1912.5	0.338	25.29	QPSK
LTE Band 2/25	24E	1852.5 - 1912.5	0.266	24.24	16QAM
LTE Band 2/25	24E	1855 - 1910	0.369	25.66	QPSK
LTE Band 2/25	24E	1855 - 1910	0.309	24.89	16QAM
LTE Band 2/25	24E	1857.5 - 1907.5	0.357	25.52	QPSK
LTE Band 2/25	24E	1857.5 - 1907.5	0.278	24.45	16QAM
LTE Band 2/25	24E	1860 - 1905	0.362	25.59	QPSK
LTE Band 2/25	24E	1860 - 1905	0.289	24.60	16QAM
LTE Band 41	27	2498.5 - 2687.5	0.208	23.17	QPSK
LTE Band 41	27	2498.5 - 2687.5	0.142	21.52	16QAM
LTE Band 41	27	2501 - 2685	0.235	23.71	QPSK
LTE Band 41	27	2501 - 2685	0.151	21.80	16QAM
LTE Band 41	27	2503.5 - 2682.5	0.229	23.59	QPSK
LTE Band 41	27	2503.5 - 2682.5	0.196	22.93	16QAM
LTE Band 41	27	2506 - 2680	0.250	23.97	QPSK
LTE Band 41	27	2506 - 2680	0.169	22.27	16QAM

EUT Overview

FCC ID: ZNFLS777	 FCC Pt. 22, 24, & 27 LTE MEASUREMENT REPORT (CLASS II PERMISSIVE CHANGE)			Approved by: Quality Manager
Test Report S/N: 1M1701030001-03.ZNF	Test Dates: 12/19/2016-1/10/17	EUT Type: Portable Handset	Page 4 of 32	

1.0 INTRODUCTION

1.1 Scope

Measurement and determination of electromagnetic emissions (EME) of radio frequency devices including intentional and/or unintentional radiators for compliance with the technical rules and regulations of the Federal Communications Commission and the Industry Canada Certification and Engineering Bureau.

1.2 Testing Facility

The map below shows the location of the PCTEST LABORATORY, its proximity to the FCC Laboratory, the Columbia vicinity, the Baltimore-Washington Intern't'l (BWI) airport, the city of Baltimore and the Washington, DC area. (See Figure 1-1).

These measurement tests were conducted at the PCTEST Engineering Laboratory, Inc. facility located at 7185 Oakland Mills Road, Columbia, MD 21046. The site coordinates are 39° 10'23" N latitude and 76° 49'50" W longitude. The facility is 0.4 miles North of the FCC laboratory, and the ambient signal and ambient signal strength are approximately equal to those of the FCC laboratory. The detailed description of the measurement facility was found to be in compliance with the requirements of § 2.948 according to ANSI C63.4-2014 on January 22, 2015.

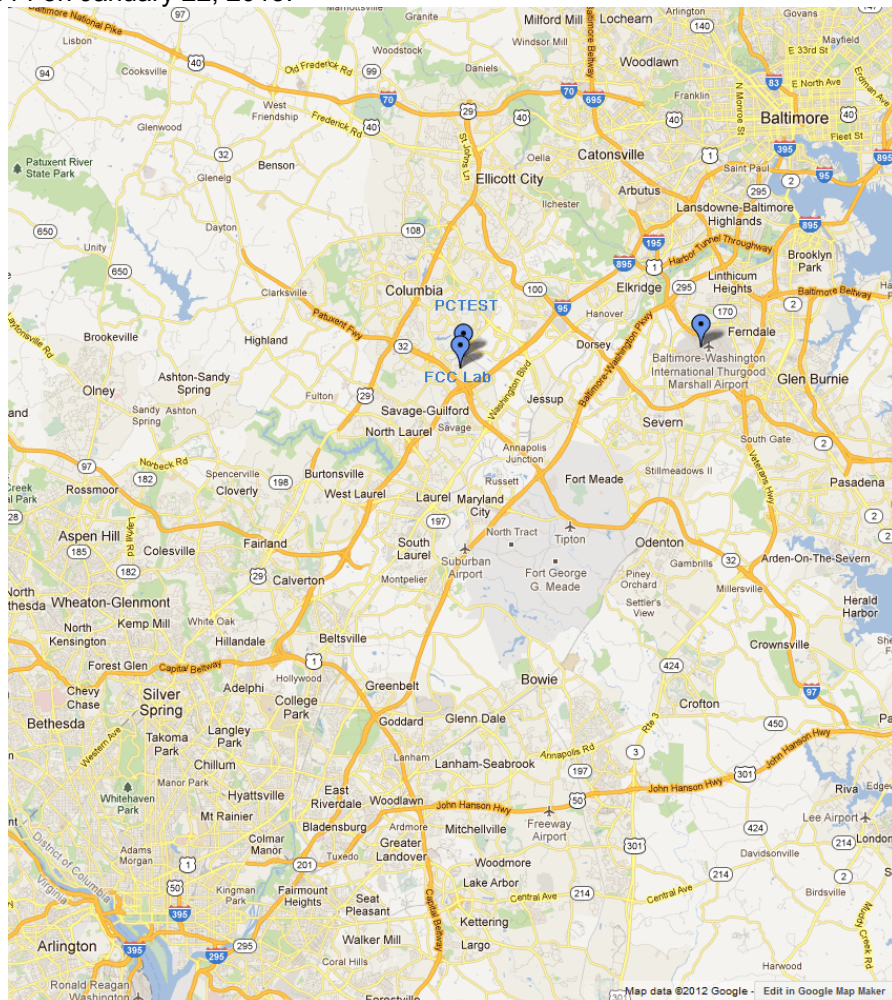

Figure 1-1. Map of the Greater Baltimore and Metropolitan Washington, D.C. area

FCC ID: ZNFLS777	PCTEST ENGINEERING LABORATORY, INC.	FCC Pt. 22, 24, & 27 LTE MEASUREMENT REPORT (CLASS II PERMISSIVE CHANGE)	LG	Approved by: Quality Manager
Test Report S/N: 1M1701030001-03.ZNF	Test Dates: 12/19/2016-1/10/17	EUT Type: Portable Handset		Page 5 of 32

2.0 PRODUCT INFORMATION

2.1 Equipment Description

The Equipment Under Test (EUT) is the **LG Portable Handset FCC ID: ZNFLS777**. The test data contained in this report pertains only to the emissions due to the EUT's LTE function.

2.2 Device Capabilities

This device contains the following capabilities:



850/1900 CDMA/EvDO Rev0/A (BC0, BC1, BC10), 850/1900 GSM/GPRS/EDGE, 850/1700/1900 WCDMA/HSPA, Multi-band LTE, 802.11b/g/n WLAN, Bluetooth (1x, EDR, LE)

2.3 Test Configuration

The EUT was tested per the guidance of ANSI/TIA-603-D-2010 and KDB 971168 D01 v02r02. See Section 7.0 of this test report for a description of the radiated and antenna port conducted emissions tests.

2.4 EMI Suppression Device(s)/Modifications

No EMI suppression device(s) were added and no modifications were made during testing.

FCC ID: ZNFLS777		FCC Pt. 22, 24, & 27 LTE MEASUREMENT REPORT (CLASS II PERMISSIVE CHANGE)		Approved by: Quality Manager
Test Report S/N: 1M1701030001-03.ZNF	Test Dates: 12/19/2016-1/10/17	EUT Type: Portable Handset	Page 6 of 32	

3.0 DESCRIPTION OF TESTS

3.1 Measurement Procedure

The measurement procedures described in the document titled “Land Mobile FM or PM – Communications Equipment – Measurements and Performance Standards” (ANSI/TIA-603-D-2010) and “Procedures for Compliance Measurement of the Fundamental Emission Power of Licensed Wideband (> 1 MHz) Digital Transmission Systems” (KDB 971168 D01 v02r02) were used in the measurement of the EUT.

3.2 Block A Frequency Range

§27.5(c)

698-746 MHz band. The following frequencies are available for licensing pursuant to this part in the 698-746 MHz band: (1) Three paired channel blocks of 12 megahertz each are available for assignment as follows:

Block A: 698-704 MHz and 728-734 MHz;
 Block B: 704-710 MHz and 734-740 MHz; and
 Block C: 710-716 MHz and 740-746 MHz.

3.3 Cellular - Base Frequency Blocks

§22.905

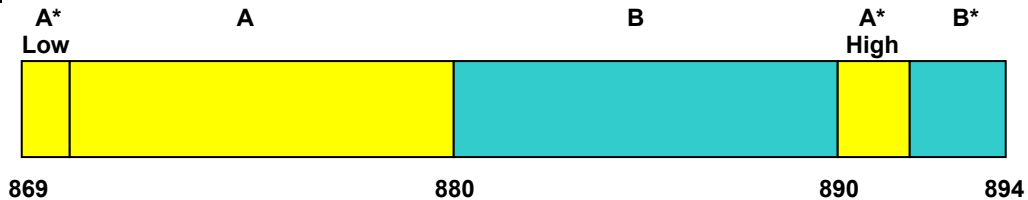

BLOCK 1: 869 – 880 MHz (A* Low + A)
BLOCK 2: 880 – 890 MHz (B)

BLOCK 3: 890 – 891.5 MHz (A* High)
BLOCK 4: 891.5 – 894 MHz (B*)

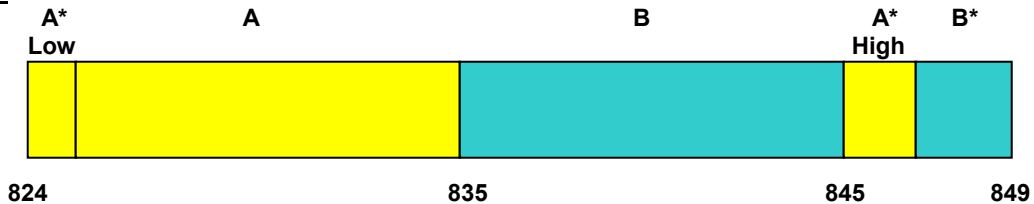

3.4 Cellular - Mobile Frequency Blocks

§22.905



BLOCK 1: 824 – 835 MHz (A* Low + A)
BLOCK 2: 835 – 845 MHz (B)

BLOCK 3: 845 – 846.5 MHz (A* High)
BLOCK 4: 846.5 – 849 MHz (B*)

FCC ID: ZNFLS777		FCC Pt. 22, 24, & 27 LTE MEASUREMENT REPORT (CLASS II PERMISSIVE CHANGE)		Approved by: Quality Manager
Test Report S/N: 1M1701030001-03.ZNF	Test Dates: 12/19/2016-1/10/17	EUT Type: Portable Handset	Page 7 of 32	

3.5 PCS - Base Frequency Blocks

§24.229

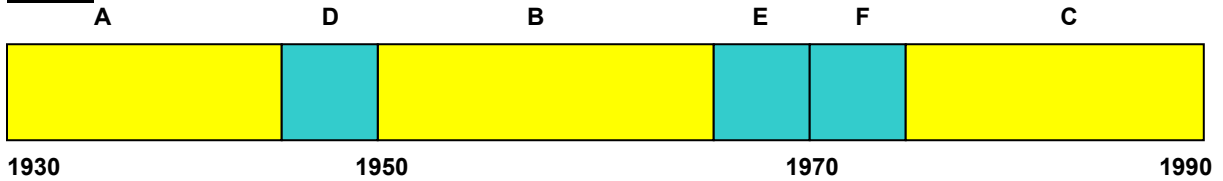

- BLOCK 1: 1930 – 1945 MHz (A)
- BLOCK 2: 1945 – 1950 MHz (D)
- BLOCK 3: 1950 – 1965 MHz (B)
- BLOCK 4: 1965 – 1970 MHz (E)
- BLOCK 5: 1970 – 1975 MHz (F)
- BLOCK 6: 1975 – 1990 MHz (C)

3.6 PCS - Mobile Frequency Blocks

§24.229

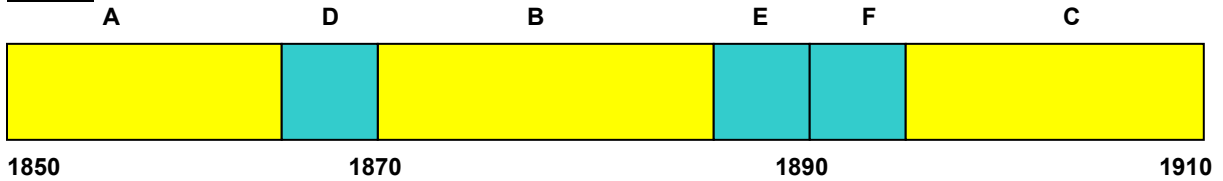

- BLOCK 1: 1850 – 1865 MHz (A)
- BLOCK 2: 1865 – 1870 MHz (D)
- BLOCK 3: 1870 – 1885 MHz (B)
- BLOCK 4: 1885 – 1890 MHz (E)
- BLOCK 5: 1890 – 1895 MHz (F)
- BLOCK 6: 1895 – 1910 MHz (C)

3.7 AWS - Base Frequency Blocks

§27.5(h)

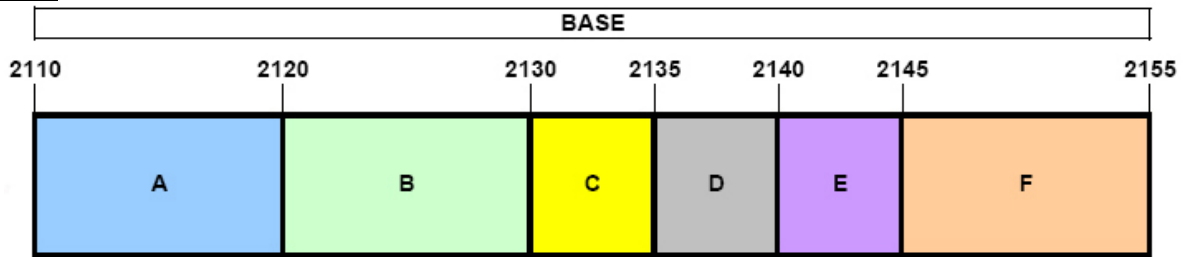

- BLOCK 1: 2110 – 2120 MHz (A)
- BLOCK 2: 2120 – 2130 MHz (B)
- BLOCK 3: 2130 – 2135 MHz (C)
- BLOCK 4: 2135 – 2140 MHz (D)
- BLOCK 5: 2140 – 2145 MHz (E)
- BLOCK 6: 2145 – 2155 MHz (F)

3.8 AWS - Mobile Frequency Blocks

§27.5(h)

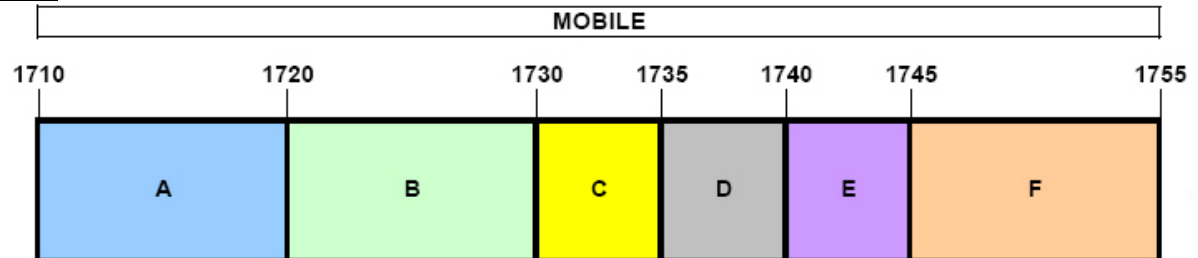

- BLOCK 1: 1710 – 1720 MHz (A)
- BLOCK 2: 1720 – 1730 MHz (B)
- BLOCK 3: 1730 – 1735 MHz (C)
- BLOCK 4: 1735 – 1740 MHz (D)
- BLOCK 5: 1740 – 1745 MHz (E)
- BLOCK 6: 1745 – 1755 MHz (F)

FCC ID: ZNFLS777	PCTEST ENGINEERING LABORATORY, INC.	FCC Pt. 22, 24, & 27 LTE MEASUREMENT REPORT (CLASS II PERMISSIVE CHANGE)	LG	Approved by: Quality Manager
Test Report S/N: 1M1701030001-03.ZNF	Test Dates: 12/19/2016-1/10/17	EUT Type: Portable Handset	Page 8 of 32	

3.9 BRS/EBS Frequency Block

§27.5

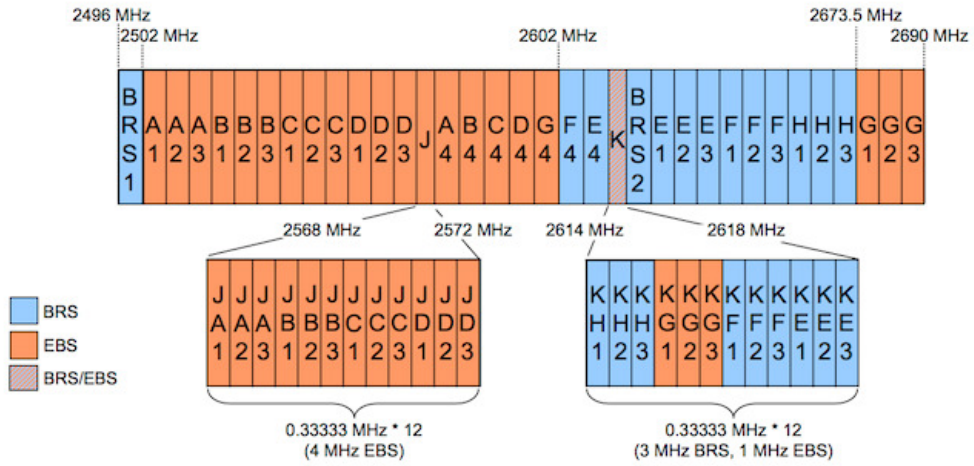

FCC ID: ZNFLS777	PCTEST ENGINEERING LABORATORY, INC.	FCC Pt. 22, 24, & 27 LTE MEASUREMENT REPORT (CLASS II PERMISSIVE CHANGE)	LG	Approved by: Quality Manager
Test Report S/N: 1M1701030001-03.ZNF	Test Dates: 12/19/2016-1/10/17	EUT Type: Portable Handset	Page 9 of 32	

3.10 Radiated Power and Radiated Spurious Emissions

§2.1053 §22.913(a.2) §22.917(a) §24.232(c) §24.238(a) §27.50(c.10) §27.50(d.4) §27.53(g) §27.53(h) §27.53(m)

The radiated test facilities consisted of an indoor 3 meter semi-anechoic chamber used for final measurements and exploratory measurements, when necessary. The measurement area is contained within the semi-anechoic chamber which is shielded from any ambient interference. The test site inside the chamber is a 6m x 5.2m elliptical, obstruction-free area in accordance with Figure 5.7 of Clause 5 in ANSI C63.4-2014. Absorbers are arranged on the floor between the turn table and the antenna mast in such a way so as to maximize the reduction of reflections for measurements above 1GHz. For measurements below 1GHz, the absorbers are removed. A raised turntable is used for radiated measurement. The turn table is a continuously rotatable, remote-controlled, metallic turntable and 2 meters (6.56 ft.) in diameter. The turn table is flush with the raised floor of the chamber in order to maintain its function as a ground plane. A 72.4cm high PVC support structure is placed on top of the turntable. A 3" (~7.6cm) sheet of high density polystyrene is used as the table top and is placed on top of the PVC supports to bring the total height of the table to 80cm.



The equipment under test was transmitting while connected to its integral antenna and is placed on a turntable 3 meters from the receive antenna. The receive antenna height is adjusted between 1 and 4 meter height, the turntable is rotated through 360 degrees, and the EUT is manipulated through all orthogonal planes representative of its typical use to achieve the highest reading on the receive spectrum analyzer. Radiated power levels are also investigated with the receive antenna horizontally and vertically polarized. The maximized power level is recorded using the spectrum analyzer "Channel Power" function with the integration band set to the emissions' occupied bandwidth, a RMS detector, RBW = 100kHz, VBW = 300kHz, and a 1 second sweep time over a minimum of 10 sweeps, per the guidelines of KDB 971168 D01 v02r02.

Per the guidance of ANSI/TIA-603-D-2010, a half-wave dipole is then substituted in place of the EUT. For emissions above 1GHz, a horn antenna is substituted in place of the EUT. The substitute antenna is driven by a signal generator with the level of the signal generator being adjusted to obtain the same receive spectrum analyzer level previously recorded from the spurious emission from the EUT. The power of the emission is calculated using the following formula:

$$P_d \text{ [dBm]} = P_g \text{ [dBm]} - \text{cable loss [dB]} + \text{antenna gain [dBd/dBi]}$$

Where, P_d is the dipole equivalent power, P_g is the generator output into the substitution antenna, and the antenna gain is the gain of the substitute antenna used relative to either a half-wave dipole (dBd) or an isotropic source (dBi). The substitute level is equal to $P_g \text{ [dBm]} - \text{cable loss [dB]}$.



The calculated P_d levels are then compared to the absolute spurious emission limit of -13dBm which is equivalent to the required minimum attenuation of $43 + 10\log_{10}(\text{Power}_{\text{[Watts]}})$. For Band 41, the calculated P_d levels are compared to the absolute spurious emission limit of -25dBm which is equivalent to the required minimum attenuation of $55 + 10\log_{10}(\text{Power}_{\text{[Watts]}})$.

FCC ID: ZNFLS777		FCC Pt. 22, 24, & 27 LTE MEASUREMENT REPORT (CLASS II PERMISSIVE CHANGE)		Approved by: Quality Manager
Test Report S/N: 1M1701030001-03.ZNF	Test Dates: 12/19/2016-1/10/17	EUT Type: Portable Handset	Page 10 of 32	

4.0 MEASUREMENT UNCERTAINTY

The measurement uncertainties shown below were calculated in accordance with the requirements of ANSI C63.10-2013. All measurement uncertainty values are shown with a coverage factor of $k = 2$ to indicate a 95% level of confidence. The measurement data shown herein meets or exceeds the U_{CISPR} measurement uncertainty values specified in CISPR 16-4-2 and, thus, can be compared directly to specified limits to determine compliance.

Contribution	Expanded Uncertainty (\pm dB)
Radiated Disturbance (<1GHz)	4.98
Radiated Disturbance (>1GHz)	5.07
Radiated Disturbance (>18GHz)	5.09

FCC ID: ZNFLS777		FCC Pt. 22, 24, & 27 LTE MEASUREMENT REPORT (CLASS II PERMISSIVE CHANGE)		Approved by: Quality Manager
Test Report S/N: 1M1701030001-03.ZNF	Test Dates: 12/19/2016-1/10/17	EUT Type: Portable Handset	Page 11 of 32	

5.0 TEST EQUIPMENT CALIBRATION DATA



Test Equipment Calibration is traceable to the National Institute of Standards and Technology (NIST). Measurements antennas used during testing were calibrated in accordance to the requirements of ANSI C63.5-2006.

Manufacturer	Model	Description	Cal Date	Cal Interval	Cal Due	Serial Number
-	RE1	Radiated Emissions Cable Set (UHF/EHF)	7/11/2016	Annual	7/11/2017	RE1
Anritsu	MT8820C	Radio Communication Analyzer	4/14/2016	Annual	4/14/2017	6201240328
ETS Lindgren	3117	1-18 GHz DRG Horn (Medium)	4/26/2016	Biennial	4/26/2018	125518
Mini Circuits	TVA-11-422	RF Power Amp	N/A			QA1317001
Mini-Circuits	SSG-4000HP	Synthesized Signal Generator	N/A			11403100002
Mini Circuits	PWR-SEN-4GHS	USB Power Sensor	3/4/2016	Annual	3/4/2017	11401010036
PCTEST	-	EMC Switch System	7/6/2016	Annual	7/6/2017	NM2
Rohde & Schwarz	CMW500	Radio Communication Tester	10/20/2016	Annual	10/20/2017	100976
Rohde & Schwarz	ESU40	EMI Test Receiver (40GHz)	7/15/2016	Annual	7/15/2017	100348
Schwarzbeck	UHA 9105	Dipole Antenna (400 - 1GHz) Rx	11/18/2015	Biennial	11/18/2017	91052523RX
Seekonk	NC-100	Torque Wrench 5/16", 8" lbs	3/2/2016	Biennial	3/2/2018	N/A

Table 5-1. Test Equipment

Notes:

Equipment with a calibration date of "N/A" shown in this list was not used to make direct calibrated measurements.



FCC ID: ZNFLS777	 FCC Pt. 22, 24, & 27 LTE MEASUREMENT REPORT (CLASS II PERMISSIVE CHANGE)			Approved by: Quality Manager
Test Report S/N: 1M1701030001-03.ZNF	Test Dates: 12/19/2016-1/10/17	EUT Type: Portable Handset	Page 12 of 32	

6.0 SAMPLE CALCULATIONS

Spurious Radiated Emission – LTE Band

Example: Middle Channel LTE Mode 2nd Harmonic (1564 MHz)

The average spectrum analyzer reading at 3 meters with the EUT on the turntable was -81.0 dBm. The gain of the substituted antenna is 8.1 dBi. The signal generator connected to the substituted antenna terminals is adjusted to produce a reading of -81.0 dBm on the spectrum analyzer. The loss of the cable between the signal generator and the terminals of the substituted antenna is 2.0 dB at 1564 MHz. So 6.1 dB is added to the signal generator reading of -30.9 dBm yielding -24.80 dBm. The fundamental EIRP was 25.501 dBm so this harmonic was 25.501 dBm $- (-24.80)$.

FCC ID: ZNFLS777		FCC Pt. 22, 24, & 27 LTE MEASUREMENT REPORT (CLASS II PERMISSIVE CHANGE)		Approved by: Quality Manager
Test Report S/N: 1M1701030001-03.ZNF	Test Dates: 12/19/2016-1/10/17	EUT Type: Portable Handset	Page 13 of 32	

7.0 TEST RESULTS

7.1 Summary



Company Name: LG Electronics MobileComm U.S.A
 FCC ID: ZNFLS777
 FCC Classification: PCS Licensed Transmitter Held to Ear (PCE)
 Mode(s): LTE

FCC Part Section(s)	Test Description	Test Limit	Test Condition	Result	Reference
22.913(a.2)	Effective Radiated Power (Band 26)	< 7 Watts max. ERP	RADIATED	PASS	Section 7.2
27.50(c.10)	Effective Radiated Power (Band 12)	< 3 Watts max. ERP		PASS	Section 7.2
24.232(c) 27.50(h.2)	Equivalent Isotropic Radiated Power (Band 25 41)	< 2 Watts max. EIRP		PASS	Section 7.2
27.50(d.4)	Equivalent Isotropic Radiated Power (Band 4)	< 1 Watts max. EIRP		PASS	Section 7.2
2.1053 22.917(a) 24.238(a) 27.53(g) 27.53(h)	Undesirable Emissions	> 43 + 10log ₁₀ (P[Watts]) for all out-of-band emissions		PASS	Section 7.3
27.53(m)	Undesirable Emissions	> 43 + 10log ₁₀ (P[Watts]) at channel edges > 55 + 10log ₁₀ (P[Watts]) at 5.5MHz away and beyond channel edges		PASS	Section 7.3

Table 7-1. Summary of Test Results

Notes:

- All modes of operation and data rates were investigated. The test results shown in the following sections represent the worst case emissions.

FCC ID: ZNFLS777		FCC Pt. 22, 24, & 27 LTE MEASUREMENT REPORT (CLASS II PERMISSIVE CHANGE)		Approved by: Quality Manager
Test Report S/N: 1M1701030001-03.ZNF	Test Dates: 12/19/2016-1/10/17	EUT Type: Portable Handset	Page 14 of 32	

7.2 Radiated Power (ERP/EIRP)

§22.913(a.2) §24.232(c.2) §27.50(h.2) §27.50(c.10) §27.50(d.4)

Test Overview

Effective Radiated Power (ERP) and Equivalent Isotropic Radiated Power (EIRP) measurements are performed using the substitution method described in ANSI/TIA-603-D-2010 with the EUT transmitting into an integral antenna. Measurements on signals operating below 1GHz are performed using vertically and horizontally polarized tuned dipole antennas. Measurements on signals operating above 1GHz are performed using vertically and horizontally polarized broadband horn antennas. All measurements are performed as RMS average measurements while the EUT is operating at its maximum duty cycle, at maximum power, and at the appropriate frequencies.



Test Procedures Used

KDB 971168 D01 v02r02 – Section 5.2.1

ANSI/TIA-603-D-2010 – Section 2.2.17

Test Settings

1. Radiated power measurements are performed using the signal analyzer's "channel power" measurement capability for signals with continuous operation. For signals with burst transmission, the signal analyzer's "time domain power" measurement capability is used
2. RBW = 1 – 5% of the expected OBW, not to exceed 1MHz
3. VBW \geq 3 x RBW
4. Span = 1.5 times the OBW
5. No. of sweep points \geq 2 x span / RBW
6. Detector = RMS
7. Trigger is set to "free run" for signals with continuous operation with the sweep times set to "auto". Trigger is set to enable triggering only on full power bursts with the sweep time set less than or equal to the transmission burst duration
8. The integration bandwidth was roughly set equal to the measured OBW of the signal for signals with continuous operation. For signals with burst transmission, the "gating" function was enabled to ensure that measurements are performed during times in which the transmitter is operating at its maximum power
9. Trace mode = trace averaging (RMS) over 100 sweeps
10. The trace was allowed to stabilize

FCC ID: ZNFLS777		FCC Pt. 22, 24, & 27 LTE MEASUREMENT REPORT (CLASS II PERMISSIVE CHANGE)		Approved by: Quality Manager
Test Report S/N: 1M1701030001-03.ZNF	Test Dates: 12/19/2016-1/10/17	EUT Type: Portable Handset	Page 15 of 32	

Test Setup

The EUT and measurement equipment were set up as shown in the diagram below.

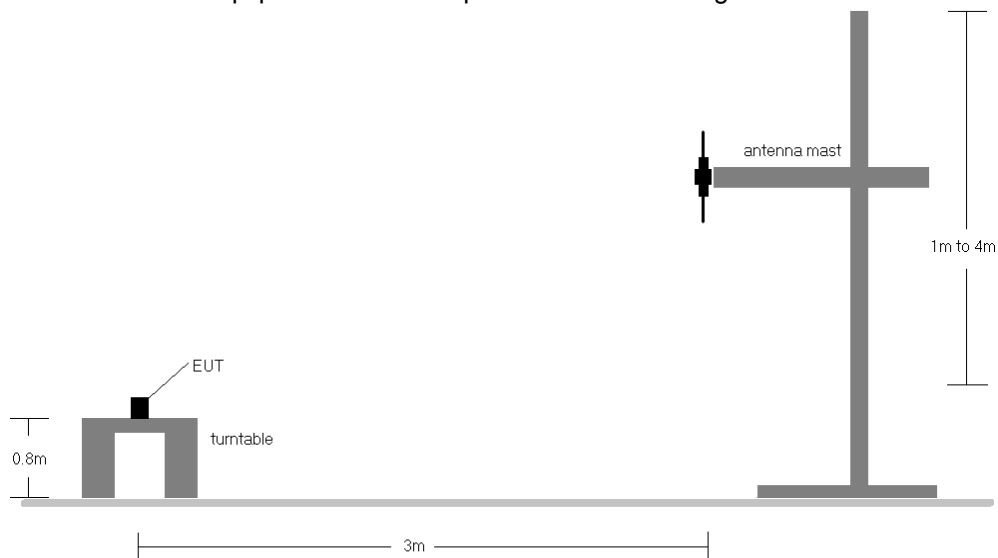

Figure 7-1. Radiated Test Setup <1GHz

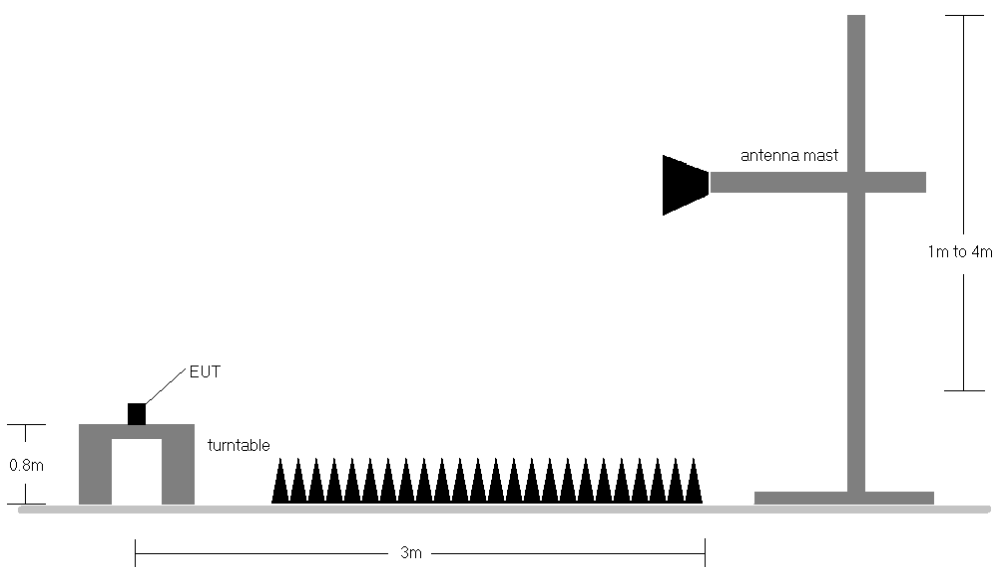



Figure 7-2. Radiated Test Setup >1GHz



Test Notes

- 1) The EUT was tested in three orthogonal planes and in all possible test configurations and positioning. The worst case emissions are reported with the EUT positioning, modulations, RB sizes and offsets, and channel bandwidth configurations shown in the tables below.
- 2) This unit was tested with its standard battery.

FCC ID: ZNFLS777		FCC Pt. 22, 24, & 27 LTE MEASUREMENT REPORT (CLASS II PERMISSIVE CHANGE)		Approved by: Quality Manager
Test Report S/N: 1M1701030001-03.ZNF	Test Dates: 12/19/2016-1/10/17	EUT Type: Portable Handset	Page 16 of 32	



Frequency [MHz]	Channel Bandwidth [MHz]	Mod.	Ant. Pol. [H/V]	Antenna Height [cm]	Turntable Azimuth [degree]	RB Size/Offset	Substitute Level [dBm]	Ant. Gain [dBd]	ERP [dBm]	ERP Limit [dBm]	Margin [dB]
699.70	1.4	QPSK	H	289	167	1 / 0	14.74	2.48	17.22	34.77	-17.55
707.50	1.4	QPSK	H	290	178	1 / 0	14.90	2.56	17.46	34.77	-17.31
715.30	1.4	QPSK	H	296	157	1 / 0	14.70	2.60	17.30	34.77	-17.48
699.70	1.4	16-QAM	H	289	167	1 / 0	13.59	2.48	16.07	34.77	-18.70
707.50	1.4	16-QAM	H	290	178	1 / 0	13.79	2.56	16.35	34.77	-18.42
715.30	1.4	16-QAM	H	296	157	1 / 0	13.67	2.60	16.27	34.77	-18.51
700.50	3	QPSK	H	282	182	1 / 0	15.32	2.48	17.80	34.77	-16.97
707.50	3	QPSK	H	290	179	1 / 0	15.42	2.56	17.98	34.77	-16.79
714.50	3	QPSK	H	262	168	1 / 14	15.44	2.60	18.04	34.77	-16.73
700.50	3	16-QAM	H	282	182	1 / 0	14.15	2.48	16.63	34.77	-18.14
707.50	3	16-QAM	H	290	179	1 / 0	14.42	2.56	16.98	34.77	-17.79
714.50	3	16-QAM	H	262	168	1 / 14	14.42	2.60	17.02	34.77	-17.75
701.50	5	QPSK	H	284	197	1 / 24	16.27	2.49	18.76	34.77	-16.01
707.50	5	QPSK	H	287	180	1 / 0	16.41	2.56	18.97	34.77	-15.80
713.50	5	QPSK	H	290	181	1 / 0	16.06	2.60	18.66	34.77	-16.11
701.50	5	16-QAM	H	284	197	1 / 24	15.00	2.49	17.49	34.77	-17.28
707.50	5	16-QAM	H	287	180	1 / 0	15.33	2.56	17.89	34.77	-16.88
713.50	5	16-QAM	H	290	181	1 / 0	15.02	2.60	17.62	34.77	-17.15
704.00	10	QPSK	H	287	157	1 / 49	16.36	2.51	18.87	34.77	-15.90
707.50	10	QPSK	H	287	180	1 / 0	16.43	2.56	18.99	34.77	-15.78
711.00	10	QPSK	H	295	168	1 / 0	16.56	2.60	19.16	34.77	-15.62
704.00	10	16-QAM	H	287	157	1 / 49	15.31	2.51	17.82	34.77	-16.95
707.50	10	16-QAM	H	287	180	1 / 0	15.25	2.56	17.81	34.77	-16.96
711.00	10	16-QAM	H	295	168	1 / 0	15.20	2.60	17.80	34.77	-16.98
711.00	10	QPSK	V	168	347	1 / 49	15.29	3.02	18.31	34.77	-16.46

Table 7-2. ERP Data (Band 12)

FCC ID: ZNFLS777	 FCC Pt. 22, 24, & 27 LTE MEASUREMENT REPORT (CLASS II PERMISSIVE CHANGE)			Approved by: Quality Manager
Test Report S/N: 1M1701030001-03.ZNF	Test Dates: 12/19/2016-1/10/17	EUT Type: Portable Handset	Page 17 of 32	



Frequency [MHz]	Channel Bandwidth [MHz]	Mod.	Ant. Pol. [H/V]	Antenna Height [cm]	Turntable Azimuth [degree]	RB Size/Offset	Substitute Level [dBm]	Ant. Gain [dBd]	ERP [dBm]	ERP Limit [dBm]	Margin [dB]
824.70	1.4	QPSK	H	378	330	1 / 5	12.00	5.51	17.51	38.45	-20.94
836.50	1.4	QPSK	H	392	350	1 / 5	11.17	5.14	16.31	38.45	-22.14
848.30	1.4	QPSK	H	399	344	1 / 0	10.96	4.68	15.64	38.45	-22.81
824.70	1.4	16-QAM	H	378	330	1 / 5	10.79	5.51	16.30	38.45	-22.15
836.50	1.4	16-QAM	H	392	350	1 / 5	10.17	5.14	15.31	38.45	-23.14
848.30	1.4	16-QAM	H	399	344	1 / 0	9.64	4.68	14.32	38.45	-24.13
825.50	3	QPSK	H	197	216	1 / 14	13.92	5.52	19.44	38.45	-19.01
836.50	3	QPSK	H	206	208	1 / 0	14.19	5.14	19.33	38.45	-19.12
847.50	3	QPSK	H	214	214	1 / 0	13.17	4.67	17.84	38.45	-20.61
825.50	3	16-QAM	H	197	216	1 / 14	12.33	5.52	17.85	38.45	-20.60
836.50	3	16-QAM	H	206	208	1 / 0	12.62	5.14	17.76	38.45	-20.69
847.50	3	16-QAM	H	214	214	1 / 0	11.30	4.67	15.97	38.45	-22.48
826.50	5	QPSK	H	202	203	1 / 0	15.16	5.51	20.67	38.45	-17.78
836.50	5	QPSK	H	206	208	1 / 0	14.99	5.14	20.13	38.45	-18.32
846.50	5	QPSK	H	212	206	1 / 24	13.75	4.66	18.41	38.45	-20.04
826.50	5	16-QAM	H	202	203	1 / 0	13.54	5.51	19.05	38.45	-19.40
836.50	5	16-QAM	H	206	208	1 / 0	13.40	5.14	18.54	38.45	-19.91
846.50	5	16-QAM	H	212	206	1 / 24	12.45	4.66	17.11	38.45	-21.34
829.00	10	QPSK	H	197	208	1 / 49	14.94	5.49	20.43	38.45	-18.02
836.50	10	QPSK	H	199	195	1 / 0	15.17	5.14	20.31	38.45	-18.14
844.00	10	QPSK	H	189	202	1 / 49	13.94	4.70	18.64	38.45	-19.81
829.00	10	16-QAM	H	197	208	1 / 49	13.46	5.49	18.95	38.45	-19.50
836.50	10	16-QAM	H	199	195	1 / 0	13.46	5.14	18.60	38.45	-19.85
844.00	10	16-QAM	H	189	202	1 / 49	12.17	4.70	16.87	38.45	-21.58
831.50	15	QPSK	H	202	212	1 / 0	14.71	5.41	20.12	38.45	-18.33
836.50	15	QPSK	H	202	202	1 / 0	14.96	5.14	20.10	38.45	-18.35
841.50	15	QPSK	H	203	204	1 / 0	14.95	4.83	19.78	38.45	-18.67
831.50	15	16-QAM	H	202	212	1 / 0	13.19	5.41	18.60	38.45	-19.85
836.50	15	16-QAM	H	202	202	1 / 0	13.45	5.14	18.59	38.45	-19.86
841.50	15	16-QAM	H	203	204	1 / 0	13.42	4.83	18.25	38.45	-20.20
826.50	5	QPSK	V	110	36	1 / 0	14.87	5.34	20.21	38.45	-18.24

Table 7-3. ERP Data (Band 5/26)

FCC ID: ZNFLS777	 FCC Pt. 22, 24, & 27 LTE MEASUREMENT REPORT (CLASS II PERMISSIVE CHANGE)			Approved by: Quality Manager
Test Report S/N: 1M1701030001-03.ZNF	Test Dates: 12/19/2016-1/10/17	EUT Type: Portable Handset	Page 18 of 32	



Frequency [MHz]	Channel Bandwidth [MHz]	Mod.	Ant. Pol. [H/V]	Antenna Height [cm]	Turntable Azimuth [degree]	RB Size/Offset	Substitute Level [dBm]	Ant. Gain [dBi]	EIRP [dBm]	EIRP Limit [dBm]	Margin [dB]
1710.70	1.4	QPSK	V	100	266	1 / 0	13.63	9.44	23.07	30.00	-6.93
1732.50	1.4	QPSK	V	100	261	1 / 0	13.91	9.32	23.23	30.00	-6.77
1754.30	1.4	QPSK	V	100	263	1 / 0	11.08	9.19	20.27	30.00	-9.73
1710.70	1.4	16-QAM	V	100	266	1 / 0	12.64	9.44	22.08	30.00	-7.92
1732.50	1.4	16-QAM	V	100	261	1 / 0	12.53	9.32	21.85	30.00	-8.15
1754.30	1.4	16-QAM	V	100	263	1 / 0	10.19	9.19	19.38	30.00	-10.62
1711.50	3	QPSK	V	100	265	1 / 14	14.44	9.44	23.88	30.00	-6.12
1732.50	3	QPSK	V	100	263	1 / 0	14.25	9.32	23.57	30.00	-6.43
1753.50	3	QPSK	V	100	265	1 / 14	12.12	9.20	21.32	30.00	-8.68
1711.50	3	16-QAM	V	100	265	1 / 14	13.55	9.44	22.99	30.00	-7.01
1732.50	3	16-QAM	V	100	263	1 / 0	12.81	9.32	22.13	30.00	-7.87
1753.50	3	16-QAM	V	100	265	1 / 14	11.36	9.20	20.56	30.00	-9.44
1712.50	5	QPSK	V	100	268	1 / 0	14.91	9.43	24.34	30.00	-5.66
1732.50	5	QPSK	V	100	266	1 / 0	14.93	9.32	24.25	30.00	-5.75
1752.50	5	QPSK	V	100	267	1 / 24	12.78	9.20	21.98	30.00	-8.02
1712.50	5	16-QAM	V	100	268	1 / 0	13.57	9.43	23.00	30.00	-7.00
1732.50	5	16-QAM	V	100	266	1 / 0	13.13	9.32	22.45	30.00	-7.55
1752.50	5	16-QAM	V	100	267	1 / 24	11.56	9.20	20.76	30.00	-9.24
1715.00	10	QPSK	V	100	265	1 / 49	15.09	9.42	24.51	30.00	-5.49
1732.50	10	QPSK	V	100	267	1 / 0	15.07	9.32	24.39	30.00	-5.61
1750.00	10	QPSK	V	100	263	1 / 49	12.95	9.22	22.17	30.00	-7.83
1715.00	10	16-QAM	V	100	265	1 / 49	14.38	9.42	23.80	30.00	-6.20
1732.50	10	16-QAM	V	100	267	1 / 0	14.32	9.32	23.64	30.00	-6.36
1750.00	10	16-QAM	V	100	263	1 / 49	12.04	9.22	21.26	30.00	-8.74
1717.50	15	QPSK	V	100	270	1 / 74	15.61	9.40	25.01	30.00	-4.99
1732.50	15	QPSK	V	101	266	1 / 0	15.59	9.32	24.91	30.00	-5.09
1747.50	15	QPSK	V	100	263	1 / 0	13.51	9.23	22.74	30.00	-7.26
1717.50	15	16-QAM	V	100	270	1 / 74	14.54	9.40	23.94	30.00	-6.06
1732.50	15	16-QAM	V	101	266	1 / 0	14.58	9.32	23.90	30.00	-6.10
1747.50	15	16-QAM	V	100	263	1 / 0	12.20	9.23	21.43	30.00	-8.57
1720.00	20	QPSK	V	103	90	1 / 99	14.71	9.39	24.10	30.00	-5.90
1732.50	20	QPSK	V	103	92	1 / 0	14.78	9.32	24.10	30.00	-5.90
1745.00	20	QPSK	V	100	92	1 / 0	14.40	9.25	23.65	30.00	-6.35
1720.00	20	16-QAM	V	103	90	1 / 99	13.16	9.39	22.55	30.00	-7.45
1732.50	20	16-QAM	V	103	92	1 / 0	13.57	9.32	22.89	30.00	-7.11
1745.00	20	16-QAM	V	100	92	1 / 0	13.39	9.25	22.64	30.00	-7.36
1717.50	15	QPSK	H	130	49	1 / 0	11.09	9.58	20.67	30.00	-9.33

Table 7-4. EIRP Data (Band 4)

FCC ID: ZNFLS777		FCC Pt. 22, 24, & 27 LTE MEASUREMENT REPORT (CLASS II PERMISSIVE CHANGE)		Approved by: Quality Manager
Test Report S/N: 1M1701030001-03.ZNF	Test Dates: 12/19/2016-1/10/17	EUT Type: Portable Handset	Page 19 of 32	



Frequency [MHz]	Channel Bandwidth [MHz]	Mod.	Ant. Pol. [H/V]	Antenna Height [cm]	Turntable Azimuth [degree]	RB Size/Offset	Substitute Level [dBm]	Ant. Gain [dBi]	EIRP [dBm]	EIRP Limit [dBm]	Margin [dB]
1850.70	1.4	QPSK	H	100	149	1 / 5	14.87	9.12	23.99	33.01	-9.02
1882.50	1.4	QPSK	H	100	152	1 / 0	15.00	9.10	24.10	33.01	-8.91
1914.30	1.4	QPSK	H	100	156	1 / 0	14.76	9.20	23.96	33.01	-9.05
1850.70	1.4	16-QAM	H	100	149	1 / 5	14.02	9.12	23.14	33.01	-9.87
1882.50	1.4	16-QAM	H	100	152	1 / 0	13.92	9.10	23.02	33.01	-9.99
1914.30	1.4	16-QAM	H	100	156	1 / 0	14.83	9.20	24.03	33.01	-8.98
1851.50	3	QPSK	H	100	154	1 / 0	15.36	9.12	24.48	33.01	-8.53
1882.50	3	QPSK	H	100	152	1 / 14	15.54	9.10	24.64	33.01	-8.37
1913.50	3	QPSK	H	100	155	1 / 0	15.67	9.19	24.86	33.01	-8.15
1851.50	3	16-QAM	H	100	154	1 / 0	14.44	9.12	23.56	33.01	-9.45
1882.50	3	16-QAM	H	100	152	1 / 14	14.63	9.10	23.73	33.01	-9.28
1913.50	3	16-QAM	H	100	155	1 / 0	14.36	9.19	23.55	33.01	-9.46
1852.50	5	QPSK	H	100	154	1 / 24	15.83	9.12	24.95	33.01	-8.06
1882.50	5	QPSK	H	100	151	1 / 0	16.05	9.10	25.15	33.01	-7.86
1912.50	5	QPSK	H	100	152	1 / 24	16.11	9.18	25.29	33.01	-7.72
1852.50	5	16-QAM	H	100	154	1 / 24	14.81	9.12	23.93	33.01	-9.08
1882.50	5	16-QAM	H	100	151	1 / 0	15.01	9.10	24.11	33.01	-8.90
1912.50	5	16-QAM	H	100	152	1 / 24	15.06	9.18	24.24	33.01	-8.77
1855.00	10	QPSK	H	100	152	1 / 0	16.25	9.12	25.37	33.01	-7.64
1882.50	10	QPSK	H	100	152	1 / 49	16.29	9.10	25.39	33.01	-7.62
1910.00	10	QPSK	H	100	155	1 / 0	16.50	9.16	25.66	33.01	-7.35
1855.00	10	16-QAM	H	100	152	1 / 0	15.27	9.12	24.39	33.01	-8.62
1882.50	10	16-QAM	H	100	152	1 / 49	15.32	9.10	24.42	33.01	-8.59
1910.00	10	16-QAM	H	100	155	1 / 0	15.73	9.16	24.89	33.01	-8.12
1857.50	15	QPSK	H	100	151	1 / 0	16.04	9.11	25.15	33.01	-7.86
1882.50	15	QPSK	H	100	154	1 / 74	16.42	9.10	25.52	33.01	-7.49
1907.50	15	QPSK	H	100	156	1 / 74	16.18	9.15	25.33	33.01	-7.68
1857.50	15	16-QAM	H	100	151	1 / 0	15.01	9.11	24.12	33.01	-8.89
1882.50	15	16-QAM	H	100	154	1 / 74	15.26	9.10	24.36	33.01	-8.65
1907.50	15	16-QAM	H	100	156	1 / 74	15.30	9.15	24.45	33.01	-8.56
1860.00	20	QPSK	H	100	151	1 / 99	15.90	9.11	25.01	33.01	-8.00
1882.50	20	QPSK	H	100	155	1 / 99	16.49	9.10	25.59	33.01	-7.42
1905.00	20	QPSK	H	100	157	1 / 99	16.33	9.13	25.46	33.01	-7.55
1860.00	20	16-QAM	H	100	151	1 / 99	14.50	9.11	23.61	33.01	-9.40
1882.50	20	16-QAM	H	100	155	1 / 99	15.50	9.10	24.60	33.01	-8.41
1905.00	20	16-QAM	H	100	157	1 / 99	15.20	9.13	24.33	33.01	-8.68
1910.00	10	QPSK	V	165	267	1 / 0	13.76	8.98	22.74	33.01	-10.27

Table 7-5. EIRP Data (Band 2/25)

FCC ID: ZNFLS777	 FCC Pt. 22, 24, & 27 LTE MEASUREMENT REPORT (CLASS II PERMISSIVE CHANGE)			Approved by: Quality Manager
Test Report S/N: 1M1701030001-03.ZNF	Test Dates: 12/19/2016-1/10/17	EUT Type: Portable Handset	Page 20 of 32	

Frequency [MHz]	Channel Bandwidth [MHz]	Mod.	Ant. Pol. [H/V]	Antenna Height [cm]	Turntable Azimuth [degree]	RB Size/Offset	Substitute Level [dBm]	Ant. Gain [dBi]	EIRP [dBm]	EIRP Limit [dBm]	Margin [dB]
2498.50	5	QPSK	H	129	81	1 / 24	14.09	8.42	22.51	33.01	-10.50
2593.00	5	QPSK	H	110	81	1 / 24	14.52	8.65	23.17	33.01	-9.84
2687.50	5	QPSK	H	110	91	1 / 24	12.38	8.44	20.82	33.01	-12.19
2498.50	5	16-QAM	H	129	81	1 / 24	12.21	8.42	20.63	33.01	-12.38
2593.00	5	16-QAM	H	110	81	1 / 24	12.87	8.65	21.52	33.01	-11.49
2687.50	5	16-QAM	H	110	91	1 / 24	11.18	8.44	19.62	33.01	-13.39
2501.00	10	QPSK	H	130	81	1 / 0	13.93	8.41	22.34	33.01	-10.67
2593.00	10	QPSK	H	120	84	1 / 49	15.06	8.65	23.71	33.01	-9.30
2685.00	10	QPSK	H	117	90	1 / 0	13.02	8.45	21.47	33.01	-11.54
2501.00	10	16-QAM	H	130	81	1 / 0	12.42	8.41	20.83	33.01	-12.18
2593.00	10	16-QAM	H	120	84	1 / 49	13.15	8.65	21.80	33.01	-11.21
2685.00	10	16-QAM	H	117	90	1 / 0	12.25	8.45	20.70	33.01	-12.31
2503.50	15	QPSK	H	129	84	1 / 74	14.92	8.42	23.34	33.01	-9.67
2593.00	15	QPSK	H	119	83	1 / 0	14.94	8.65	23.59	33.01	-9.42
2682.50	15	QPSK	H	110	92	1 / 74	12.63	8.46	21.09	33.01	-11.92
2503.50	15	16-QAM	H	129	84	1 / 74	10.53	8.42	18.95	33.01	-14.06
2593.00	15	16-QAM	H	119	83	1 / 0	14.28	8.65	22.93	33.01	-10.08
2682.50	15	16-QAM	H	110	92	1 / 74	13.55	8.46	22.01	33.01	-11.00
2506.00	20	QPSK	H	125	80	1 / 99	14.70	8.42	23.12	33.01	-9.89
2593.00	20	QPSK	H	120	78	1 / 99	15.32	8.65	23.97	33.01	-9.04
2680.00	20	QPSK	H	114	90	1 / 99	12.53	8.46	20.99	33.01	-12.02
2506.00	20	16-QAM	H	125	80	1 / 99	13.85	8.42	22.27	33.01	-10.74
2593.00	20	16-QAM	H	120	78	1 / 99	12.42	8.65	21.07	33.01	-11.94
2680.00	20	16-QAM	H	114	90	1 / 99	9.99	8.46	18.45	33.01	-14.56
2593.00	20	QPSK	V	110	263	1 / 99	11.69	8.74	20.43	33.01	-12.58

Table 7-6. EIRP Data (Band 41)

FCC ID: ZNFLS777	 FCC Pt. 22, 24, & 27 LTE MEASUREMENT REPORT (CLASS II PERMISSIVE CHANGE)			Approved by: Quality Manager
Test Report S/N: 1M1701030001-03.ZNF	Test Dates: 12/19/2016-1/10/17	EUT Type: Portable Handset	Page 21 of 32	

7.3 Radiated Spurious Emissions Measurements

§2.1053 §22.917(a) §24.238(a) §27.53(g) §27.53(h) §27.53(m)

Test Overview

Radiated spurious emissions measurements are performed using the substitution method described in ANSI/TIA-603-D-2010 with the EUT transmitting into an integral antenna. Measurements on signals operating below 1GHz are performed using vertically and horizontally polarized tuned dipole antennas. Measurements on signals operating above 1GHz are performed using vertically and horizontally polarized broadband horn antennas. All measurements are performed as peak measurements while the EUT is operating at its maximum duty cycle, at maximum power, and at the appropriate frequencies.



Test Procedures Used

KDB 971168 D01 v02r02 – Section 5.8

ANSI/TIA-603-D-2010 – Section 2.2.12

Test Settings

1. RBW = 100kHz for emissions below 1GHz and 1MHz for emissions above 1GHz
2. VBW $\geq 3 \times$ RBW
3. Span = 1.5 times the OBW
4. No. of sweep points $\geq 2 \times$ span / RBW
5. Detector = RMS
6. Trace mode = Average (Max Hold for pulsed emissions)
7. The trace was allowed to stabilize

FCC ID: ZNFLS777		FCC Pt. 22, 24, & 27 LTE MEASUREMENT REPORT (CLASS II PERMISSIVE CHANGE)		Approved by: Quality Manager
Test Report S/N: 1M1701030001-03.ZNF	Test Dates: 12/19/2016-1/10/17	EUT Type: Portable Handset	Page 22 of 32	

Test Setup

The EUT and measurement equipment were set up as shown in the diagram below.

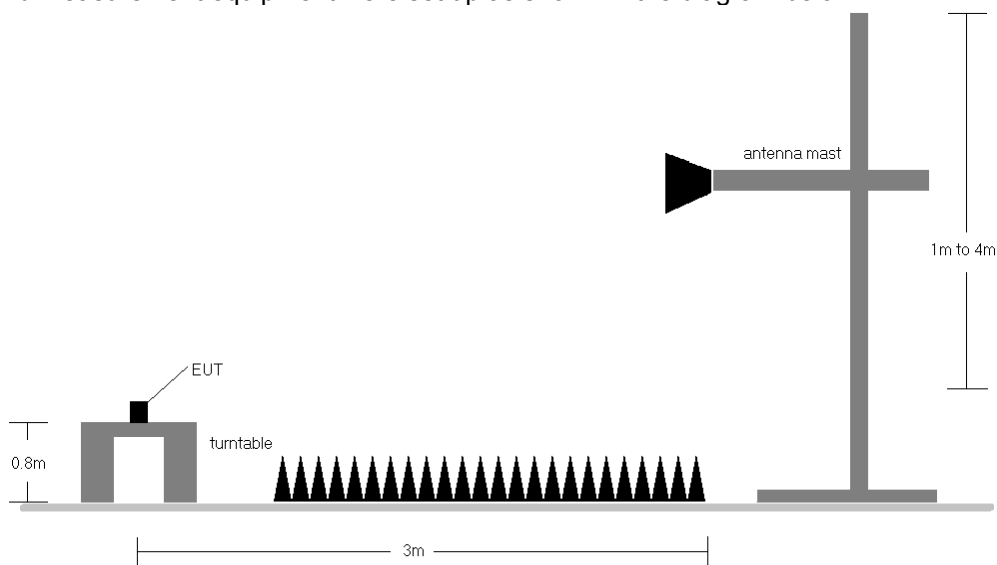



Figure 7-3. Test Instrument & Measurement Setup

Test Notes

- 1) The EUT was tested in three orthogonal planes and in all possible test configurations and positioning. The worst case emissions are reported with the EUT positioning, modulations, RB sizes and offsets, and channel bandwidth configurations shown in the tables below.
- 2) This unit was tested with its standard battery.
- 3) The spectrum is measured from 9kHz to the 10th harmonic of the fundamental frequency of the transmitter. The worst-case emissions are reported.
- 4) Emissions below 18GHz were measured at a 3 meter test distance while emissions above 18GHz were measured at a 1 meter test distance with the application of a distance correction factor.
- 5) The "-" shown in the following RSE tables are used to denote a noise floor measurement.

FCC ID: ZNFLS777		FCC Pt. 22, 24, & 27 LTE MEASUREMENT REPORT (CLASS II PERMISSIVE CHANGE)		Approved by: Quality Manager
Test Report S/N: 1M1701030001-03.ZNF	Test Dates: 12/19/2016-1/10/17	EUT Type: Portable Handset		Page 23 of 32

OPERATING FREQUENCY: 704.00 MHz
 CHANNEL: 23060
 MEASURED OUTPUT POWER: 18.87 dBm = 0.077 W
 MODULATION SIGNAL: QPSK
 BANDWIDTH: 10.0 MHz
 DISTANCE: 3 meters
 LIMIT: $43 + 10 \log_{10}(W) =$ 31.87 dBc



Frequency [MHz]	Ant. Pol. [H/V]	Antenna Height [cm]	Turntable Azimuth [degree]	Level at Antenna Terminals [dBm]	Substitute Antenna Gain [dBd]	Spurious Emission Level [dBm]	[dBc]
1408.00	H	100	280	-54.88	5.94	-48.94	67.8
2112.00	H	100	31	-62.30	6.82	-55.48	74.4
2816.00	H	-	-	-63.96	8.13	-55.83	74.7
3520.00	H	-	-	-60.51	7.76	-52.75	71.6

Table 7-7. Radiated Spurious Data (Band 12 – Low Channel)

OPERATING FREQUENCY: 707.50 MHz
 CHANNEL: 23095
 MEASURED OUTPUT POWER: 18.99 dBm = 0.079 W
 MODULATION SIGNAL: QPSK
 BANDWIDTH: 10.0 MHz
 DISTANCE: 3 meters
 LIMIT: $43 + 10 \log_{10}(W) =$ 31.99 dBc

Frequency [MHz]	Ant. Pol. [H/V]	Antenna Height [cm]	Turntable Azimuth [degree]	Level at Antenna Terminals [dBm]	Substitute Antenna Gain [dBd]	Spurious Emission Level [dBm]	[dBc]
1415.00	H	100	279	-56.62	5.96	-50.66	69.6
2122.50	H	100	97	-62.90	6.84	-56.06	75.0
2830.00	H	-	-	-64.04	8.13	-55.90	74.9
3537.50	H	-	-	-60.51	7.79	-52.72	71.7

Table 7-8. Radiated Spurious Data (Band 12 – Mid Channel)

FCC ID: ZNFLS777		FCC Pt. 22, 24, & 27 LTE MEASUREMENT REPORT (CLASS II PERMISSIVE CHANGE)		Approved by: Quality Manager
Test Report S/N: 1M1701030001-03.ZNF	Test Dates: 12/19/2016-1/10/17	EUT Type: Portable Handset	Page 24 of 32	

OPERATING FREQUENCY: 711.00 MHz
 CHANNEL: 23130
 MEASURED OUTPUT POWER: 19.16 dBm = 0.082 W
 MODULATION SIGNAL: QPSK
 BANDWIDTH: 10.0 MHz
 DISTANCE: 3 meters
 LIMIT: $43 + 10 \log_{10}(W) =$ 32.16 dBc



Frequency [MHz]	Ant. Pol. [H/V]	Antenna Height [cm]	Turntable Azimuth [degree]	Level at Antenna Terminals [dBm]	Substitute Antenna Gain [dBd]	Spurious Emission Level [dBm]	[dBc]
1422.00	H	100	280	-55.42	5.99	-49.43	68.6
2133.00	H	100	103	-63.21	6.87	-56.34	75.5
2844.00	H	-	-	-63.15	8.14	-55.01	74.2
3555.00	H	-	-	-64.06	7.82	-56.24	75.4

Table 7-9. Radiated Spurious Data (Band 12 – High Channel)

OPERATING FREQUENCY: 826.50 MHz
 CHANNEL: 26815
 MEASURED OUTPUT POWER: 20.67 dBm = 0.117 W
 MODULATION SIGNAL: QPSK
 BANDWIDTH: 5.0 MHz
 DISTANCE: 3 meters
 LIMIT: $43 + 10 \log_{10}(W) =$ 33.67 dBc

Frequency [MHz]	Ant. Pol. [H/V]	Antenna Height [cm]	Turntable Azimuth [degree]	Level at Antenna Terminals [dBm]	Substitute Antenna Gain [dBi]	Spurious Emission Level [dBm]	[dBc]
1653.00	H	110	10	-75.54	6.70	-68.85	89.5
2479.50	H	110	80	-73.14	7.54	-65.60	86.3
3306.00	H	-	-	-69.26	7.38	-61.88	82.5
4132.50	H	-	-	-68.51	8.10	-60.41	81.1

Table 7-10. Radiated Spurious Data (Band 5/26 – Low Channel)

FCC ID: ZNFLS777		FCC Pt. 22, 24, & 27 LTE MEASUREMENT REPORT (CLASS II PERMISSIVE CHANGE)		Approved by: Quality Manager
Test Report S/N: 1M1701030001-03.ZNF	Test Dates: 12/19/2016-1/10/17	EUT Type: Portable Handset	Page 25 of 32	

OPERATING FREQUENCY: 836.50 MHz
 CHANNEL: 26915
 MEASURED OUTPUT POWER: 20.13 dBm = 0.103 W
 MODULATION SIGNAL: QPSK
 BANDWIDTH: 5.0 MHz
 DISTANCE: 3 meters
 LIMIT: $43 + 10 \log_{10}(W) =$ 33.13 dBc



Frequency [MHz]	Ant. Pol. [H/V]	Antenna Height [cm]	Turntable Azimuth [degree]	Level at Antenna Terminals [dBm]	Substitute Antenna Gain [dBd]	Spurious Emission Level [dBm]	[dBc]
1673.00	H	110	12	-74.71	6.70	-68.02	88.1
2509.50	H	134	284	-70.81	7.63	-63.18	83.3
3346.00	H	-	-	-69.40	7.51	-61.89	82.0
4182.50	H	-	-	-68.46	8.23	-60.23	80.4

Table 7-11. Radiated Spurious Data (Band 5/26 – Mid Channel)

OPERATING FREQUENCY: 846.50 MHz
 CHANNEL: 27015
 MEASURED OUTPUT POWER: 18.41 dBm = 0.069 W
 MODULATION SIGNAL: QPSK
 BANDWIDTH: 5.0 MHz
 DISTANCE: 3 meters
 LIMIT: $43 + 10 \log_{10}(W) =$ 31.41 dBc

Frequency [MHz]	Ant. Pol. [H/V]	Antenna Height [cm]	Turntable Azimuth [degree]	Level at Antenna Terminals [dBm]	Substitute Antenna Gain [dBd]	Spurious Emission Level [dBm]	[dBc]
1693.00	H	110	19	-72.93	6.70	-66.23	84.6
2539.50	H	162	295	-71.12	7.60	-63.52	81.9
3386.00	H	-	-	-69.68	7.65	-62.03	80.4
4232.50	H	-	-	-68.34	8.37	-59.97	78.4

Table 7-12. Radiated Spurious Data (Band 5/26 – High Channel)

FCC ID: ZNFLS777		FCC Pt. 22, 24, & 27 LTE MEASUREMENT REPORT (CLASS II PERMISSIVE CHANGE)		Approved by: Quality Manager
Test Report S/N: 1M1701030001-03.ZNF	Test Dates: 12/19/2016-1/10/17	EUT Type: Portable Handset	Page 26 of 32	

OPERATING FREQUENCY: 1717.50 MHz
 CHANNEL: 20025
 MEASURED OUTPUT POWER: 25.01 dBm = 0.317 W
 MODULATION SIGNAL: QPSK
 BANDWIDTH: 15.0 MHz
 DISTANCE: 3 meters
 LIMIT: $43 + 10 \log_{10}(W) =$ 38.01 dBc



Frequency [MHz]	Ant. Pol. [H/V]	Antenna Height [cm]	Turntable Azimuth [degree]	Level at Antenna Terminals [dBm]	Substitute Antenna Gain [dBi]	Spurious Emission Level [dBm]	[dBc]
3435.00	V	170	92	-50.72	9.79	-40.94	66.0
5152.50	V	110	257	-55.79	10.69	-45.10	70.1
6870.00	V	-	-	-58.61	11.70	-46.91	71.9
8587.50	V	-	-	-55.29	11.03	-44.26	69.3

Table 7-13. Radiated Spurious Data (Band 4 – Low Channel)

OPERATING FREQUENCY: 1732.50 MHz
 CHANNEL: 20175
 MEASURED OUTPUT POWER: 24.91 dBm = 0.310 W
 MODULATION SIGNAL: QPSK
 BANDWIDTH: 15.0 MHz
 DISTANCE: 3 meters
 LIMIT: $43 + 10 \log_{10}(W) =$ 37.91 dBc

Frequency [MHz]	Ant. Pol. [H/V]	Antenna Height [cm]	Turntable Azimuth [degree]	Level at Antenna Terminals [dBm]	Substitute Antenna Gain [dBi]	Spurious Emission Level [dBm]	[dBc]
3465.00	V	146	296	-56.47	9.85	-46.62	71.5
5197.50	V	149	178	-57.40	10.59	-46.80	71.7
6930.00	V	-	-	-59.72	11.76	-47.96	72.9
8662.50	V	-	-	-54.03	10.97	-43.05	68.0

Table 7-14. Radiated Spurious Data (Band 4 – Mid Channel)

FCC ID: ZNFLS777		FCC Pt. 22, 24, & 27 LTE MEASUREMENT REPORT (CLASS II PERMISSIVE CHANGE)		Approved by: Quality Manager
Test Report S/N: 1M1701030001-03.ZNF	Test Dates: 12/19/2016-1/10/17	EUT Type: Portable Handset	Page 27 of 32	

OPERATING FREQUENCY: 1747.50 MHz
 CHANNEL: 20325
 MEASURED OUTPUT POWER: 22.74 dBm = 0.188 W
 MODULATION SIGNAL: QPSK
 BANDWIDTH: 15.0 MHz
 DISTANCE: 3 meters
 LIMIT: $43 + 10 \log_{10}(W) =$ 35.74 dBc



Frequency [MHz]	Ant. Pol. [H/V]	Antenna Height [cm]	Turntable Azimuth [degree]	Level at Antenna Terminals [dBm]	Substitute Antenna Gain [dBi]	Spurious Emission Level [dBm]	[dBc]
3495.00	V	142	83	-51.51	9.91	-41.60	64.3
5242.50	V	110	290	-63.29	10.64	-52.65	75.4
6990.00	V	-	-	-58.58	11.77	-46.80	69.5
8737.50	V	-	-	-54.41	10.96	-43.45	66.2

Table 7-15. Radiated Spurious Data (Band 4 – High Channel)

OPERATING FREQUENCY: 1855.00 MHz
 CHANNEL: 26090
 MEASURED OUTPUT POWER: 25.37 dBm = 0.344 W
 MODULATION SIGNAL: QPSK
 BANDWIDTH: 10.0 MHz
 DISTANCE: 3 meters
 LIMIT: $43 + 10 \log_{10}(W) =$ 38.37 dBc

Frequency [MHz]	Ant. Pol. [H/V]	Antenna Height [cm]	Turntable Azimuth [degree]	Level at Antenna Terminals [dBm]	Substitute Antenna Gain [dBi]	Spurious Emission Level [dBm]	[dBc]
3710.00	H	-	-	-65.76	9.51	-56.26	81.6
5565.00	H	110	214	-58.25	11.06	-47.19	72.6
7420.00	H	-	-	-57.19	10.97	-46.22	71.6
9275.00	H	-	-	-55.13	11.53	-43.60	69.0

Table 7-16. Radiated Spurious Data (Band 2/25 – Low Channel)

FCC ID: ZNFLS777		FCC Pt. 22, 24, & 27 LTE MEASUREMENT REPORT (CLASS II PERMISSIVE CHANGE)		Approved by: Quality Manager
Test Report S/N: 1M1701030001-03.ZNF	Test Dates: 12/19/2016-1/10/17	EUT Type: Portable Handset	Page 28 of 32	

OPERATING FREQUENCY: 1882.50 MHz
 CHANNEL: 26365
 MEASURED OUTPUT POWER: 25.39 dBm = 0.346 W
 MODULATION SIGNAL: QPSK
 BANDWIDTH: 10.0 MHz
 DISTANCE: 3 meters
 LIMIT: $43 + 10 \log_{10}(W) =$ 38.39 dBc



Frequency [MHz]	Ant. Pol. [H/V]	Antenna Height [cm]	Turntable Azimuth [degree]	Level at Antenna Terminals [dBm]	Substitute Antenna Gain [dBi]	Spurious Emission Level [dBm]	[dBc]
3765.00	H	-	-	-65.28	9.37	-55.91	81.3
5647.50	H	161	226	-58.11	11.23	-46.88	72.3
7530.00	H	-	-	-56.65	11.13	-45.52	70.9
9412.50	H	-	-	-54.42	11.55	-42.87	68.3

Table 7-17. Radiated Spurious Data (Band 2/25 – Mid Channel)

OPERATING FREQUENCY: 1910.00 MHz
 CHANNEL: 26640
 MEASURED OUTPUT POWER: 25.66 dBm = 0.369 W
 MODULATION SIGNAL: QPSK
 BANDWIDTH: 10.0 MHz
 DISTANCE: 3 meters
 LIMIT: $43 + 10 \log_{10}(W) =$ 38.66 dBc

Frequency [MHz]	Ant. Pol. [H/V]	Antenna Height [cm]	Turntable Azimuth [degree]	Level at Antenna Terminals [dBm]	Substitute Antenna Gain [dBi]	Spurious Emission Level [dBm]	[dBc]
3820.00	H	-	-	-64.90	9.32	-55.57	81.2
5730.00	H	110	232	-49.57	11.37	-38.20	63.9
7640.00	H	-	-	-57.31	11.33	-45.98	71.6
9550.00	H	-	-	-54.59	11.78	-42.81	68.5

Table 7-18. Radiated Spurious Data (Band 2/25 – High Channel)

FCC ID: ZNFLS777		FCC Pt. 22, 24, & 27 LTE MEASUREMENT REPORT (CLASS II PERMISSIVE CHANGE)		Approved by: Quality Manager
Test Report S/N: 1M1701030001-03.ZNF	Test Dates: 12/19/2016-1/10/17	EUT Type: Portable Handset	Page 29 of 32	

OPERATING FREQUENCY: 2506.00 MHz
 CHANNEL: 39750
 MEASURED OUTPUT POWER: 23.12 dBm = 0.205 W
 MODULATION SIGNAL: QPSK
 BANDWIDTH: 20.0 MHz
 DISTANCE: 3 meters
 LIMIT: $55 + 10 \log_{10}(W)$ 48.12 dBc



Frequency [MHz]	Ant. Pol. [H/V]	Antenna Height [cm]	Turntable Azimuth [degree]	Level at Antenna Terminals [dBm]	Substitute Antenna Gain [dBi]	Spurious Emission Level [dBm]	[dBc]
5012.00	H	-	-	-52.34	10.91	-41.42	64.5
7518.00	H	133	169	-46.91	11.10	-35.81	58.9
10024.00	H	-	-	-44.41	12.07	-32.34	55.5
12530.00	H	-	-	-44.46	13.55	-30.91	54.0

Table 7-19. Radiated Spurious Data (Band 41 – Low Channel)

OPERATING FREQUENCY: 2593.00 MHz
 CHANNEL: 40620
 MEASURED OUTPUT POWER: 23.97 dBm = 0.250 W
 MODULATION SIGNAL: QPSK
 BANDWIDTH: 20.0 MHz
 DISTANCE: 3 meters
 LIMIT: $55 + 10 \log_{10}(W)$ 48.97 dBc

Frequency [MHz]	Ant. Pol. [H/V]	Antenna Height [cm]	Turntable Azimuth [degree]	Level at Antenna Terminals [dBm]	Substitute Antenna Gain [dBi]	Spurious Emission Level [dBm]	[dBc]
5186.00	H	1228	81	-44.74	10.75	-33.99	58.0
7779.00	H	129	80	-42.45	11.40	-31.05	55.0
10372.00	H	-	-	-45.38	12.59	-32.79	56.8
12965.00	H	-	-	-44.66	13.37	-31.30	55.3



Table 7-20. Radiated Spurious Data (Band 41 – Mid Channel)

FCC ID: ZNFLS777		FCC Pt. 22, 24, & 27 LTE MEASUREMENT REPORT (CLASS II PERMISSIVE CHANGE)		Approved by: Quality Manager
Test Report S/N: 1M1701030001-03.ZNF	Test Dates: 12/19/2016-1/10/17	EUT Type: Portable Handset	Page 30 of 32	

OPERATING FREQUENCY: 2680.00 MHz
 CHANNEL: 41490
 MEASURED OUTPUT POWER: 20.99 dBm = 0.126 W
 MODULATION SIGNAL: QPSK
 BANDWIDTH: 20.0 MHz
 DISTANCE: 3 meters
 LIMIT: $55 + 10 \log_{10}(W)$ 45.99 dBc



Frequency [MHz]	Ant. Pol. [H/V]	Antenna Height [cm]	Turntable Azimuth [degree]	Level at Antenna Terminals [dBm]	Substitute Antenna Gain [dBi]	Spurious Emission Level [dBm]	[dBc]
5360.00	H	-	-	-53.92	10.74	-43.18	64.2
8040.00	H	-	-	-46.34	11.14	-35.20	56.2
10720.00	H	-	-	-45.72	12.77	-32.95	53.9
13400.00	H	-	-	-41.48	12.57	-28.91	49.9

Table 7-21. Radiated Spurious Data (Band 41 – High Channel)

FCC ID: ZNFLS777		FCC Pt. 22, 24, & 27 LTE MEASUREMENT REPORT (CLASS II PERMISSIVE CHANGE)		Approved by: Quality Manager
Test Report S/N: 1M1701030001-03.ZNF	Test Dates: 12/19/2016-1/10/17	EUT Type: Portable Handset	Page 31 of 32	

8.0 CONCLUSION

The data collected relate only to the item(s) tested and show that the **LG Portable Handset** **FCC ID: ZNFLS777** complies with all the requirements of Parts 22, 24, & 27 of the FCC rules for LTE operation only.

FCC ID: ZNFLS777		FCC Pt. 22, 24, & 27 LTE MEASUREMENT REPORT (CLASS II PERMISSIVE CHANGE)		Approved by: Quality Manager
Test Report S/N: 1M1701030001-03.ZNF	Test Dates: 12/19/2016-1/10/17	EUT Type: Portable Handset	Page 32 of 32	