



## MEASUREMENT REPORT FCC Part 22, 24, & 27 LTE

**Applicant Name:**  
LG Electronics MobileComm U.S.A  
1000 Sylvan Avenue  
Englewood Cliffs, NJ 07632  
United States

**Date of Testing:**  
10/12-10/16/2015, 11/17 - 11/27/2015  
**Test Site/Location:**  
PCTEST Lab., Columbia, MD, USA  
**Test Report Serial No.:**  
0Y1511161951.ZNF

**FCC ID :** ZNFLS675  
**APPLICANT:** LG ELECTRONICS MOBILECOMM U.S.A

**Application Type:** Certification  
**FCC Classification:** PCS Licensed Transmitter Held to Ear (PCE)  
**FCC Rule Part(s):** §2; §22; §24; §27  
**Test Procedure(s):** ANSI/TIA-603-C-2004, KDB 971168 D01 v02r02  
**EUT Type:** Portable Handset  
**Model(s):** LG-LS675, LGLS675, LS675  
**Test Device Serial No.:** identical prototype [S/N: 35349507000381, 35349507000767]



Mode	Tx Frequency (MHz)	Emission Designator	Modulation	ERP/EIRP	
				Max. Power (W)	Max. Power (dBm)
LTE Band 26	824.7 - 848.3	1M12G7D	QPSK	0.067	18.28
LTE Band 26	824.7 - 848.3	1M13W7D	16QAM	0.056	17.45
LTE Band 26	825.5 - 847.5	2M72G7D	QPSK	0.070	18.45
LTE Band 26	825.5 - 847.5	2M72W7D	16QAM	0.058	17.60
LTE Band 26	826.5 - 846.5	4M51G7D	QPSK	0.090	19.56
LTE Band 26	826.5 - 846.5	4M56W7D	16QAM	0.076	18.78
LTE Band 26	829 - 844	8M97G7D	QPSK	0.077	18.85
LTE Band 26	829 - 844	8M96W7D	16QAM	0.071	18.49
LTE Band 26	831.5 - 841.5	13M5G7D	QPSK	0.081	19.06
LTE Band 26	831.5 - 841.5	13M5W7D	16QAM	0.064	18.06
LTE Band 25	1850.7 - 1914.3	1M11G7D	QPSK	0.276	24.40
LTE Band 25	1850.7 - 1914.3	1M12W7D	16QAM	0.228	23.57
LTE Band 25	1851.5 - 1913.5	2M73G7D	QPSK	0.269	24.30
LTE Band 25	1851.5 - 1913.5	2M72W7D	16QAM	0.227	23.56
LTE Band 25	1852.5 - 1912.5	4M50G7D	QPSK	0.253	24.03
LTE Band 25	1852.5 - 1912.5	4M52W7D	16QAM	0.208	23.19
LTE Band 25	1855 - 1910	8M99G7D	QPSK	0.177	22.47
LTE Band 25	1855 - 1910	8M96W7D	16QAM	0.143	21.56
LTE Band 25	1857.5 - 1907.5	13M5G7D	QPSK	0.184	22.65
LTE Band 25	1857.5 - 1907.5	13M5W7D	16QAM	0.167	22.22
LTE Band 25	1860 - 1905	17M9G7D	QPSK	0.191	22.81
LTE Band 25	1860 - 1905	17M9W7D	16QAM	0.152	21.83
LTE Band 41	2498.5 - 2687.5	4M52G7D	QPSK	0.099	19.96
LTE Band 41	2498.5 - 2687.5	4M50W7D	16QAM	0.079	18.96
LTE Band 41	2501 - 2685	8M99G7D	QPSK	0.159	22.02
LTE Band 41	2501 - 2685	8M99W7D	16QAM	0.116	20.65
LTE Band 41	2503.5 - 2682.5	13M5G7D	QPSK	0.087	19.41
LTE Band 41	2503.5 - 2682.5	13M5W7D	16QAM	0.075	18.78
LTE Band 41	2506 - 2680	18M0G7D	QPSK	0.085	19.27
LTE Band 41	2506 - 2680	18M0W7D	16QAM	0.080	19.05

This equipment has been shown to be capable of compliance with the applicable technical standards as indicated in the measurement report and was tested in accordance with the measurement procedures specified in §2.947. Test results reported herein relate only to the item(s) tested.

I attest to the accuracy of data. All measurements reported herein were performed by me or were made under my supervision and are correct to the best of my knowledge and belief. I assume full responsibility for the completeness of these measurements and vouch for the qualifications of all persons taking them.



  
Randy Ortanez  
President



<b>FCC ID:</b> ZNFLS675		<b>FCC Pt. 22, 24, &amp; 27 LTE MEASUREMENT REPORT (CERTIFICATION)</b>		<b>Reviewed by:</b> Quality Manager
<b>Test Report S/N:</b> 0Y1511161951.ZNF	<b>Test Dates:</b> 10/12-10/16/2015, 11/17 - 11/27/2015	<b>EUT Type:</b> Portable Handset	Page 1 of 110	

# T A B L E O F C O N T E N T S

FCC PART 22, 24, & 27 MEASUREMENT REPORT .....		3
1.0 INTRODUCTION .....		4
1.1 Scope.....		4
1.2 Testing Facility.....		4
2.0 PRODUCT INFORMATION.....		5
2.1 Equipment Description.....		5
2.2 Device Capabilities .....		5
2.3 Test Configuration.....		5
2.4 EMI Suppression Device(s)/Modifications.....		5
3.0 DESCRIPTION OF TESTS .....		6
3.1 Measurement Procedure.....		6
3.2 Cellular - Base Frequency Blocks .....		6
3.3 Cellular - Mobile Frequency Blocks.....		6
3.4 PCS - Base Frequency Blocks.....		6
3.5 PCS - Mobile Frequency Blocks .....		7
3.6 BRS/EBS Frequency Block.....		7
3.7 Radiated Power and Radiated Spurious Emissions.....		8
4.0 MEASUREMENT UNCERTAINTY .....		9
5.0 TEST EQUIPMENT CALIBRATION DATA .....		10
6.0 SAMPLE CALCULATIONS .....		12
7.0 TEST RESULTS .....		13
7.1 Summary.....		13
7.2 Occupied Bandwidth .....		14
7.3 Spurious and Harmonic Emissions at Antenna Terminal .....		30
7.4 Band Edge Emissions at Antenna Terminal.....		58
7.5 Peak-Average Ratio.....		84
7.6 Radiated Power (ERP/EIRP) .....		91
7.7 Radiated Spurious Emissions Measurements.....		96
7.8 Frequency Stability / Temperature Variation.....		103
8.0 CONCLUSION.....		110

<b>FCC ID:</b> ZNFLS675		<b>FCC Pt. 22, 24, &amp; 27 LTE MEASUREMENT REPORT (CERTIFICATION)</b>		<b>Reviewed by:</b> Quality Manager
<b>Test Report S/N:</b> 0Y1511161951.ZNF	<b>Test Dates:</b> 10/12-10/16/2015, 11/17 - 11/27/2015	<b>EUT Type:</b> Portable Handset	Page 2 of 110	

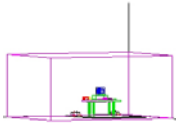

# MEASUREMENT REPORT

## FCC Part 22, 24, & 27

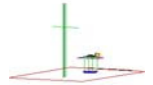

### §2.1033 General Information



**APPLICANT:** LG Electronics MobileComm U.S.A  
**APPLICANT ADDRESS:** 1000 Sylvan Avenue  
 Englewood Cliffs, NJ 07632, United States  
**TEST SITE:** PCTEST ENGINEERING LABORATORY, INC.  
**TEST SITE ADDRESS:** 7185 Oakland Mills Road, Columbia, MD 21045 USA  
**FCC RULE PART(S):** §2; §22; §24; §27  
**BASE MODEL:** LG-LS675  
**FCC ID:** ZNFLS675  
**FCC CLASSIFICATION:** PCS Licensed Transmitter Held to Ear (PCE)  
**FREQUENCY TOLERANCE:** ±0.00025 % (2.5 ppm)  
**Test Device Serial No.:** 35349507000381,  Production  Pre-Production  Engineering  
 35349507000767  
**DATE(S) OF TEST:** 10/12-10/16/2015, 11/17 - 11/27/2015  
**TEST REPORT S/N:** 0Y1511161951.ZNF

### Test Facility / Accreditations

Measurements were performed at PCTEST Engineering Lab located in Columbia, MD 21046, U.S.A.

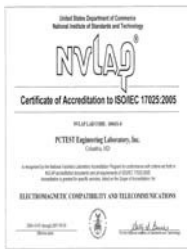
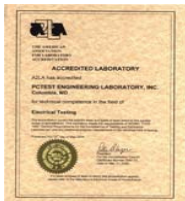
- PCTEST facility is an FCC registered (PCTEST Reg. No. 159966) test facility with the site description report on file and has met all the requirements specified in Section 2.948 of the FCC Rules and Industry Canada (2451B-1).
- PCTEST Lab is accredited to ISO 17025 by U.S. National Institute of Standards and Technology (NIST) under the National Voluntary Laboratory Accreditation Program (NVLAP Lab code: 100431-0) in EMC, FCC and Telecommunications.
- PCTEST Lab is accredited to ISO 17025-2005 by the American Association for Laboratory Accreditation (A2LA) in Specific Absorption Rate (SAR) testing, Hearing Aid Compatibility (HAC) testing, CTIA Test Plans, and wireless testing for FCC and Industry Canada Rules.
- PCTEST Lab is a recognized U.S. Conformity Assessment Body (CAB) in EMC and R&TTE (n.b. 0982) under the U.S.-EU Mutual Recognition Agreement (MRA).
- PCTEST TCB is a Telecommunication Certification Body (TCB) accredited to ISO/IEC Guide 65 by the American National Standards Institute (ANSI) in all scopes of FCC Rules and Industry Canada Standards (RSS).
- PCTEST facility is an IC registered (2451B-1) test laboratory with the site description on file at Industry Canada.
- PCTEST is a CTIA Authorized Test Laboratory (CATL) for AMPS, CDMA, and EvDO wireless devices and for Over-the-Air (OTA) Antenna Performance testing for AMPS, CDMA, GSM, GPRS, EGPRS, UMTS (W-CDMA), CDMA 1xEVDO, and CDMA 1xRTT.



FCC ID: ZNFLS675		FCC Pt. 22, 24, & 27 LTE MEASUREMENT REPORT (CERTIFICATION)		Reviewed by: Quality Manager
Test Report S/N: 0Y1511161951.ZNF	Test Dates: 10/12-10/16/2015, 11/17 - 11/27/2015	EUT Type: Portable Handset	Page 3 of 110	

# 1.0 INTRODUCTION

## 1.1 Scope

Measurement and determination of electromagnetic emissions (EME) of radio frequency devices including intentional and/or unintentional radiators for compliance with the technical rules and regulations of the Federal Communications Commission and the Industry Canada Certification and Engineering Bureau.

## 1.2 Testing Facility

The map below shows the location of the PCTEST LABORATORY, its proximity to the FCC Laboratory, the Columbia vicinity, the Baltimore-Washington Intern't'l (BWI) airport, the city of Baltimore and the Washington, DC area. (See Figure 1-1).

These measurement tests were conducted at the PCTEST Engineering Laboratory, Inc. facility located at 7185 Oakland Mills Road, Columbia, MD 21046. The site coordinates are 39° 10'23" N latitude and 76° 49'50" W longitude. The facility is 0.4 miles North of the FCC laboratory, and the ambient signal and ambient signal strength are approximately equal to those of the FCC laboratory. The detailed description of the measurement facility was found to be in compliance with the requirements of § 2.948 according to ANSI C63.4-2014 on January 22, 2015.

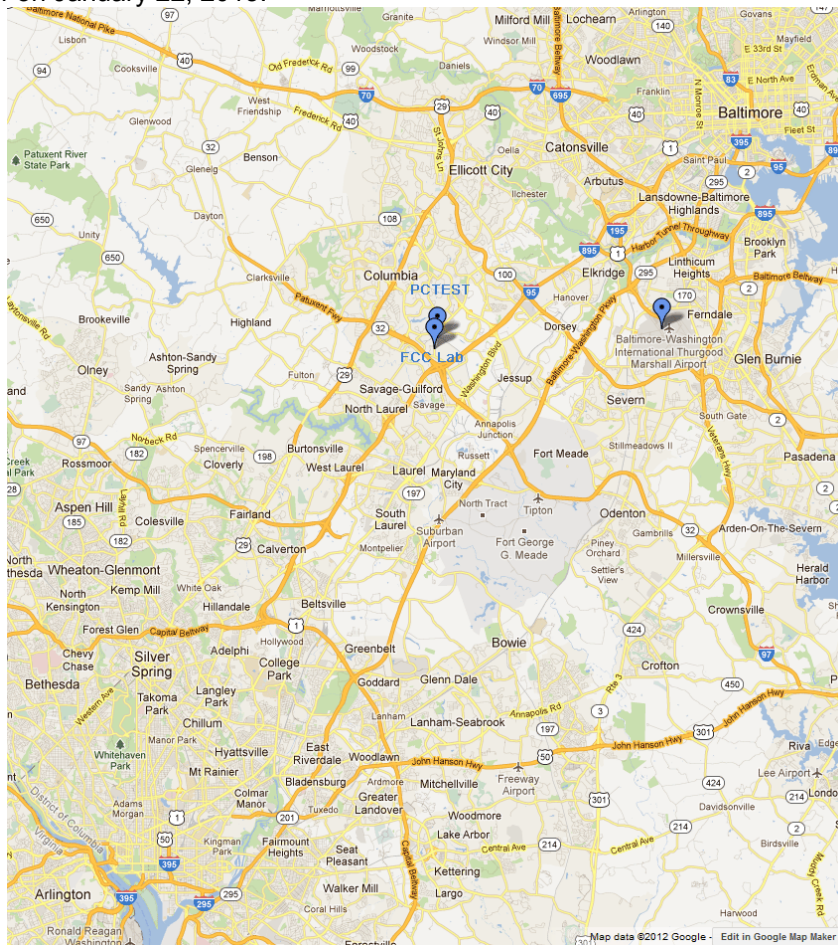



Figure 1-1. Map of the Greater Baltimore and Metropolitan Washington, D.C. area

FCC ID: ZNFLS675		FCC Pt. 22, 24, & 27 LTE MEASUREMENT REPORT (CERTIFICATION)		Reviewed by: Quality Manager
Test Report S/N: 0Y1511161951.ZNF	Test Dates: 10/12-10/16/2015, 11/17 - 11/27/2015	EUT Type: Portable Handset		Page 4 of 110

## 2.0 PRODUCT INFORMATION

### 2.1 Equipment Description

The Equipment Under Test (EUT) is the **LG Portable Handset FCC ID: ZNFLS675**. The test data contained in this report pertains only to the emissions due to the EUT's LTE function.

### 2.2 Device Capabilities

This device contains the following capabilities:



850/1900 CDMA/EvDO Rev0/A (BC0, BC1, BC10), 850/1900 GSM/GPRS/EDGE, 850/1900 WCDMA/HSPA, Multi-band LTE, 802.11b/g/n WLAN, Bluetooth (1x, EDR, LE)

### 2.3 Test Configuration

The LG Portable Handset FCC ID: ZNFLS675 was tested per the guidance of ANSI/TIA-603-C-2004 and KDB 971168 D01 v02r02. See Section 7.0 of this test report for a description of the radiated and antenna port conducted emissions tests.

### 2.4 EMI Suppression Device(s)/Modifications

No EMI suppression device(s) were added and no modifications were made during testing.

FCC ID: ZNFLS675		FCC Pt. 22, 24, & 27 LTE MEASUREMENT REPORT (CERTIFICATION)		Reviewed by: Quality Manager
Test Report S/N: 0Y1511161951.ZNF	Test Dates: 10/12-10/16/2015, 11/17 - 11/27/2015	EUT Type: Portable Handset		Page 5 of 110

## 3.0 DESCRIPTION OF TESTS

### 3.1 Measurement Procedure

The measurement procedures described in the document titled “Land Mobile FM or PM – Communications Equipment – Measurements and Performance Standards” (ANSI/TIA-603-C-2004) and “Procedures for Compliance Measurement of the Fundamental Emission Power of Licensed Wideband (> 1 MHz) Digital Transmission Systems” (KDB 971168 D01 v02r02) were used in the measurement of the **LG Portable Handset FCC ID: ZNFLS675**.

### 3.2 Cellular - Base Frequency Blocks

§22.905

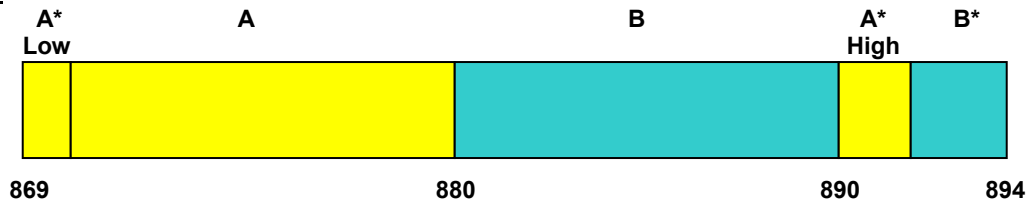

**BLOCK 1:** 869 – 880 MHz (A\* Low + A)

**BLOCK 2:** 880 – 890 MHz (B)

**BLOCK 3:** 890 – 891.5 MHz (A\* High)

**BLOCK 4:** 891.5 – 894 MHz (B\*)

### 3.3 Cellular - Mobile Frequency Blocks

§22.905

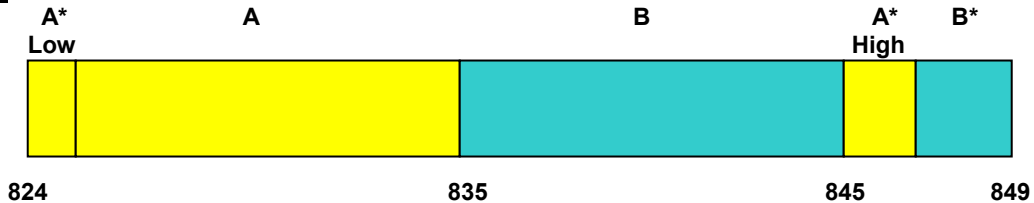

**BLOCK 1:** 824 – 835 MHz (A\* Low + A)

**BLOCK 2:** 835 – 845 MHz (B)

**BLOCK 3:** 845 – 846.5 MHz (A\* High)

**BLOCK 4:** 846.5 – 849 MHz (B\*)

### 3.4 PCS - Base Frequency Blocks

§24.229

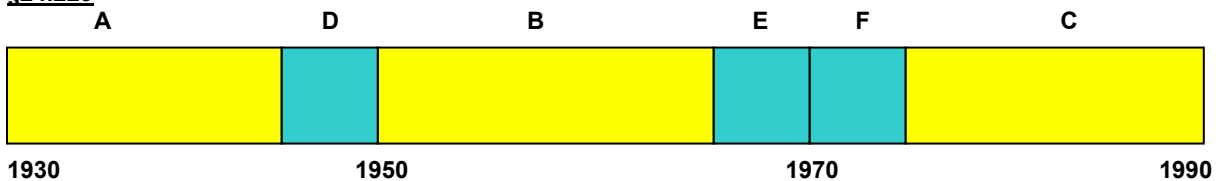

**BLOCK 1:** 1930 – 1945 MHz (A)



**BLOCK 2:** 1945 – 1950 MHz (D)

**BLOCK 3:** 1950 – 1965 MHz (B)

**BLOCK 4:** 1965 – 1970 MHz (E)

**BLOCK 5:** 1970 – 1975 MHz (F)

**BLOCK 6:** 1975 – 1990 MHz (C)

FCC ID: ZNFLS675		FCC Pt. 22, 24, & 27 LTE MEASUREMENT REPORT (CERTIFICATION)		Reviewed by: Quality Manager
Test Report S/N: 0Y1511161951.ZNF	Test Dates: 10/12-10/16/2015, 11/17 - 11/27/2015	EUT Type: Portable Handset	Page 6 of 110	

### 3.5 PCS - Mobile Frequency Blocks

§24.229

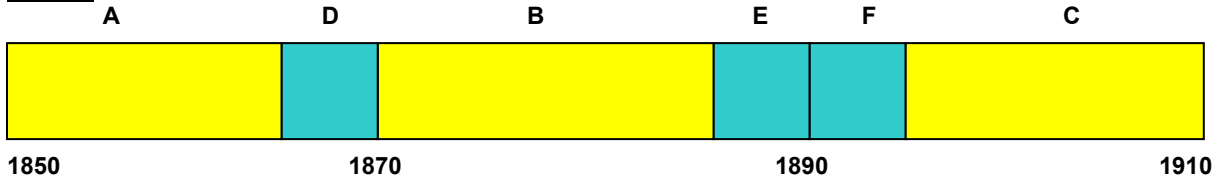

- |                                     |                                     |
|-------------------------------------|-------------------------------------|
| <b>BLOCK 1:</b> 1850 – 1865 MHz (A) | <b>BLOCK 4:</b> 1885 – 1890 MHz (E) |
| <b>BLOCK 2:</b> 1865 – 1870 MHz (D) | <b>BLOCK 5:</b> 1890 – 1895 MHz (F) |
| <b>BLOCK 3:</b> 1870 – 1885 MHz (B) | <b>BLOCK 6:</b> 1895 – 1910 MHz (C) |

### 3.6 BRS/EBS Frequency Block

§27.5

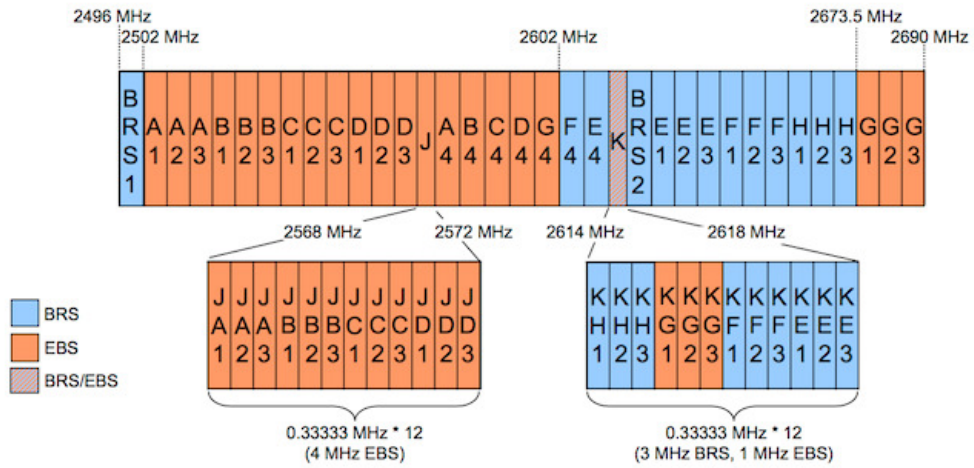

FCC ID: ZNFLS675		FCC Pt. 22, 24, & 27 LTE MEASUREMENT REPORT (CERTIFICATION)		Reviewed by: Quality Manager
Test Report S/N: 0Y1511161951.ZNF	Test Dates: 10/12-10/16/2015, 11/17 - 11/27/2015	EUT Type: Portable Handset		Page 7 of 110

### 3.7 Radiated Power and Radiated Spurious Emissions

§2.1053 §22.913(a.2) §22.917(a) §24.232(c) §24.238(a)§27.53(m)

The radiated test facilities consisted of an indoor 3 meter semi-anechoic chamber used for final measurements and exploratory measurements, when necessary. The measurement area is contained within the semi-anechoic chamber which is shielded from any ambient interference. The test site inside the chamber is a 6m x 5.2m elliptical, obstruction-free area in accordance with Clause 5, Figure 5.7 of ANSI C63.4-2009. For measurements above 1GHz absorbers are arranged on the floor between the turn table and the antenna mast in such a way so as to maximize the reduction of reflections. For measurements below 1GHz, the absorbers are removed. An ETS Lindgren Model 2188 raised turntable is used for radiated measurement. It is a continuously rotatable, remote-controlled, metallic turntable and 2 meters (6.56 ft.) in diameter. The turn table is flush with the raised floor of the chamber in order to maintain its function as a ground plane. A 78cm high PVC support structure is placed on top of the turntable. A 3/4" (~1.9cm) sheet of high density polyethylene is used as the table top and is placed on top of the PVC supports to bring the total height of the table to 80cm.



The equipment under test was transmitting while connected to its integral antenna and is placed on a turntable 3 meters from the receive antenna. The receive antenna height is adjusted between 1 and 4 meter height, the turntable is rotated through 360 degrees, and the EUT is manipulated through all orthogonal planes representative of its typical use to achieve the highest reading on the receive spectrum analyzer. Radiated power levels are also investigated with the receive antenna horizontally and vertically polarized. The maximized power level is recorded using the spectrum analyzer "Channel Power" function with the integration band set to the emissions' occupied bandwidth, a RMS detector, RBW = 100kHz, VBW = 300kHz, and a 1 second sweep time over a minimum of 10 sweeps, per the guidelines of KDB 971168.

Per the guidance of ANSI/TIA-603-C-2004, a half-wave dipole is then substituted in place of the EUT. For emissions above 1GHz, a horn antenna is substituted in place of the EUT. The substitute antenna is driven by a signal generator with the level of the signal generator being adjusted to obtain the same receive spectrum analyzer level previously recorded from the spurious emission from the EUT. The power of the emission is calculated using the following formula:

$$P_d \text{ [dBm]} = P_g \text{ [dBm]} - \text{cable loss [dB]} + \text{antenna gain [dBd/dBi]}$$

Where,  $P_d$  is the dipole equivalent power,  $P_g$  is the generator output into the substitution antenna, and the antenna gain is the gain of the substitute antenna used relative to either a half-wave dipole (dBd) or an isotropic source (dBi). The substitute level is equal to  $P_g \text{ [dBm]} - \text{cable loss [dB]}$ .

The calculated  $P_d$  levels are then compared to the absolute spurious emission limit of -13dBm which is equivalent to the required minimum attenuation of  $43 + 10\log_{10}(\text{Power}_{\text{[Watts]}})$ . For Band 41, the calculated  $P_d$  levels are compared to the absolute spurious emission limit of -25dBm which is equivalent to the required minimum attenuation of  $55 + 10\log_{10}(\text{Power}_{\text{[Watts]}})$ .



FCC ID: ZNFLS675		FCC Pt. 22, 24, & 27 LTE MEASUREMENT REPORT (CERTIFICATION)		Reviewed by: Quality Manager
Test Report S/N: 0Y1511161951.ZNF	Test Dates: 10/12-10/16/2015, 11/17 - 11/27/2015	EUT Type: Portable Handset	Page 8 of 110	



## 4.0 MEASUREMENT UNCERTAINTY

The measurement uncertainties shown below were calculated in accordance with the requirements of ANSI C63.4-2014. All measurement uncertainty values are shown with a coverage factor of  $k = 2$  to indicate a 95% level of confidence. The measurement data shown herein meets or exceeds the  $U_{\text{CISPR}}$  measurement uncertainty values specified in CISPR 16-4-2 and, thus, can be compared directly to specified limits to determine compliance.

Contribution	Expanded Uncertainty ( $\pm$ dB)
Conducted Bench Top Measurements	1.13
Radiated Disturbance (<1GHz)	4.98
Radiated Disturbance (>1GHz)	5.07
Radiated Disturbance (>18GHz)	5.09



FCC ID: ZNFLS675		FCC Pt. 22, 24, & 27 LTE MEASUREMENT REPORT (CERTIFICATION)		Reviewed by: Quality Manager
Test Report S/N: 0Y1511161951.ZNF	Test Dates: 10/12-10/16/2015, 11/17 - 11/27/2015	EUT Type: Portable Handset		Page 9 of 110

## 5.0 TEST EQUIPMENT CALIBRATION DATA

Test Equipment Calibration is traceable to the National Institute of Standards and Technology (NIST).

Manufacturer	Model	Description	Cal Date	Cal Interval	Cal Due	Serial Number
-	LTx1	Licensed Transmitter Cable Set	4/16/2015	Annual	4/16/2016	N/A
-	RE1	Radiated Emissions Cable Set (UHF/EHF)	4/28/2015	Annual	4/28/2016	N/A
Agilent	8447D	Broadband Amplifier	6/12/2015	Annual	6/12/2016	2443A01900
Agilent	N9020A	MXA Signal Analyzer	10/27/2014	Annual	10/27/2015	US46470561
Com-Power	AL-130	9kHz - 30MHz Loop Antenna	7/30/2015	Biennial	7/30/2017	121034
Emco	3115	Horn Antenna (1-18GHz)	1/30/2014	Biennial	1/30/2016	9704-5182
Espec	ESX-2CA	Environmental Chamber	3/17/2015	Annual	3/17/2016	17620
ETS Lindgren	3117	1-18 GHz DRG Horn (Medium)	4/8/2014	Biennial	4/8/2016	125518
ETS Lindgren	3160-09	18-26.5 GHz Standard Gain Horn	6/17/2014	Biennial	6/17/2016	135427
ETS Lindgren	3164-08	Quad Ridge Horn Antenna	10/22/2014	Biennial	10/22/2016	128338
K & L	11SH10-3075/U18000	High Pass Filter	12/1/2014	Annual	12/1/2015	2
K & L	11SH10-3075/U18000	High Pass Filter	12/1/2014	Annual	12/1/2015	1
K & L	13SH10-1000/U1000	N Type High Pass Filter	12/1/2014	Annual	12/1/2015	1
K & L	13SH10-1000/U1000	N Type High Pass Filter	12/1/2014	Annual	12/1/2015	2
Mini-Circuits	PWR-SENS-4RMS	USB Power Sensor	3/11/2015	Annual	3/11/2016	11210140001
Mini-Circuits	SSG-4000HP	USB Synthesized Signal Generator	N/A			11208010032
Mini-Circuits	TVA-11-422	RF Power Amp	N/A			QA1303002
Rhode & Schwarz	TS-PR18	Pre-Amplifier	3/5/2015	Annual	3/5/2016	101622
Rohde & Schwarz	CMW500	Radio Communication Tester	N/A			100976
Rohde & Schwarz	ESU26	EMI Test Receiver (26.5GHz)	3/12/2015	Annual	3/12/2016	100342
Rohde & Schwarz	ESU40	EMI Test Receiver (40GHz)	7/17/2015	Annual	7/17/2016	100348
Rohde & Schwarz	TS-PR18	1-18 GHz Pre-Amplifier	3/5/2015	Annual	3/5/2016	100071
Rohde & Schwarz	TS-PR26	18-26.5 GHz Pre-Amplifier	3/3/2015	Annual	3/3/2016	100040
Schwarzbeck	UHA 9105	Dipole Antenna (400 - 1GHz) Rx	11/21/2013	Biennial	11/21/2015	9105-2404
Seekonk	NC-100	Torque Wrench 5/16", 8" lbs	3/18/2014	Biennial	3/18/2016	N/A
Sunol	JB5	Bi-Log Antenna (30M - 5GHz)	1/28/2014	Biennial	1/28/2016	A051107
VWR	62344-734	Thermometer with Clock	2/20/2014	Biennial	2/20/2016	140140336

**Table 5-1. Test Equipment for 10/12 – 10/16/2015**



FCC ID: ZNFLS675		FCC Pt. 22, 24, & 27 LTE MEASUREMENT REPORT (CERTIFICATION)		Reviewed by: Quality Manager
Test Report S/N: 0Y1511161951.ZNF	Test Dates: 10/12-10/16/2015, 11/17 - 11/27/2015	EUT Type: Portable Handset	Page 10 of 110	

Manufacturer	Model	Description	Cal Date	Cal Interval	Cal Due	Serial Number
-	LTX3	Licensed Transmitter Cable Set	6/12/2015	Annual	6/12/2016	LTX3
-	RE1	Radiated Emissions Cable Set (UHF/EHF)	4/28/2015	Annual	4/28/2016	RE1
Agilent	8447D	Broadband Amplifier	6/12/2015	Annual	6/12/2016	2443A01900
Agilent	E5515C	Wireless Communications Test Set	N/A			GB46110872
Agilent	N9020A	MXA Signal Analyzer	11/5/2015	Annual	11/5/2016	US46470561
Emco	3115	Horn Antenna (1-18GHz)	1/30/2014	Biennial	1/30/2016	9704-5182
Emco	6502	Active Loop Antenna (10k - 30 MHz)	6/24/2014	Biennial	6/24/2016	267
Espec	ESX-2CA	Environmental Chamber	3/17/2015	Annual	3/17/2016	17620
ETS Lindgren	3117	1-18 GHz DRG Horn (Medium)	4/8/2014	Biennial	4/8/2016	125518
ETS Lindgren	3160-09	18-26.5 GHz Standard Gain Horn	6/17/2014	Biennial	6/17/2016	135427
K & L	11SH10-3075/U18000	High Pass Filter	12/1/2014	Annual	12/1/2015	11SH10-3075/U18000-2
K & L	11SH10-3075/U18000	High Pass Filter	12/1/2014	Annual	12/1/2015	11SH10-3075/U18000-4
Mini Circuits	PWR-SEN-4GHS	USB Power Sensor	3/11/2015	Annual	3/11/2016	11401010036
Mini Circuits	TVA-11-422	RF Power Amp	N/A			QA1317001
Mini-Circuits	PWR-SENS-4RMS	USB Power Sensor	3/11/2015	Annual	3/11/2016	11210140001
Mini-Circuits	SSG-4000HP	Synthesized Signal Generator	N/A			11208010032
Mini-Circuits	TVA-11-422	RF Power Amp	N/A			QA1303002
Rhode & Schwarz	TS-PR18	Pre-Amplifier	3/5/2015	Annual	3/5/2016	101622
Rohde & Schwarz	CMU200	Base Station Simulator	N/A			107826
Rohde & Schwarz	CMW500	Radio Communication Tester	10/13/2015	Annual	10/13/2016	100976
Rohde & Schwarz	ESU26	EMI Test Receiver (26.5GHz)	3/12/2015	Annual	3/12/2016	100342
Rohde & Schwarz	TS-PR18	1-18 GHz Pre-Amplifier	3/5/2015	Annual	3/5/2016	100071
Rohde & Schwarz	TS-PR26	18-26.5 GHz Pre-Amplifier	3/3/2015	Annual	3/3/2016	100040
Schwarzbeck	UHA 9105	Dipole Antenna (400 - 1GHz) Rx	11/21/2013	Biennial	11/21/2015	9105-2404
Seekonk	NC-100	Torque Wrench 5/16", 8" lbs	3/18/2014	Biennial	3/18/2016	N/A
Sunol	JB5	Bi-Log Antenna (30M - 5GHz)	1/28/2014	Biennial	1/28/2016	A051107
VWR	62344-734	Thermometer with Clock	2/20/2014	Biennial	2/20/2016	140140336

**Table 5-2. Test Equipment for 11/17 – 11/27/2015**

**Notes:**

1. For equipment listed above that has a calibration date or calibration due date that falls within the test date range, care was taken to ensure that this equipment was used after the calibration date and before the calibration due date.
2. Equipment with a calibration date of "N/A" shown in this list was not used to make direct calibrated measurements.

FCC ID: ZNFLS675		FCC Pt. 22, 24, & 27 LTE MEASUREMENT REPORT (CERTIFICATION)		Reviewed by: Quality Manager
Test Report S/N: 0Y1511161951.ZNF	Test Dates: 10/12-10/16/2015, 11/17 - 11/27/2015	EUT Type: Portable Handset	Page 11 of 110	

## 6.0 SAMPLE CALCULATIONS

### Emission Designator

#### QPSK Modulation

**Emission Designator = 8M62G7D**

LTE BW = 8.62 MHz  
 G = Phase Modulation  
 7 = Quantized/Digital Info  
 D = Data transmission, telemetry, telecommand

#### 16QAM Modulation



**Emission Designator = 8M45W7D**

LTE BW = 8.45 MHz  
 W = Amplitude/Angle Modulated  
 7 = Quantized/Digital Info  
 D = Data transmission, telemetry, telecommand

### Spurious Radiated Emission – LTE Band

#### **Example: Middle Channel LTE Mode 2<sup>nd</sup> Harmonic (1564 MHz)**

The average spectrum analyzer reading at 3 meters with the EUT on the turntable was  $-81.0$  dBm. The gain of the substituted antenna is 8.1 dBi. The signal generator connected to the substituted antenna terminals is adjusted to produce a reading of  $-81.0$  dBm on the spectrum analyzer. The loss of the cable between the signal generator and the terminals of the substituted antenna is 2.0 dB at 1564 MHz. So 6.1 dB is added to the signal generator reading of  $-30.9$  dBm yielding  $-24.80$  dBm. The fundamental EIRP was 25.501 dBm so this harmonic was 25.501 dBm – ( $-24.80$ ).

FCC ID: ZNFLS675		FCC Pt. 22, 24, & 27 LTE MEASUREMENT REPORT (CERTIFICATION)		Reviewed by: Quality Manager
Test Report S/N: 0Y1511161951.ZNF	Test Dates: 10/12-10/16/2015, 11/17 - 11/27/2015	EUT Type: Portable Handset	Page 12 of 110	

## 7.0 TEST RESULTS

### 7.1 Summary



Company Name: LG Electronics MobileComm U.S.A  
 FCC ID: ZNFLS675  
 FCC Classification: PCS Licensed Transmitter Held to Ear (PCE)  
 Mode(s): LTE

FCC Part Section(s)	Test Description	Test Limit	Test Condition	Result	Reference
<b>TRANSMITTER MODE (TX)</b>					
2.1049	Occupied Bandwidth	N/A	CONDUCTED	PASS	Section 7.2
2.1051 22.917(a) 24.238(a)	Out of Band Emissions	> 43 + 10log <sub>10</sub> (P[Watts]) at Band Edge and for all out-of-band emissions		PASS	Section 7.3, 7.4
27.53(m)	Out of Band Emissions	> 43 + 10log <sub>10</sub> (P[Watts]) at channel edges and > 55 + 10log <sub>10</sub> (P[Watts]) at 5.5MHz away and beyond channel edges		PASS	Section 7.3, 7.4
24.232(d)	Peak-Average Ratio	< 13 dB		PASS	Section 7.5
2.1046	Transmitter Conducted Output Power	N/A		PASS	See RF Exposure Report
2.1055. 22.355 24.235 27.54	Frequency Stability	< 2.5 ppm (Part 22) and fundamental emissions stay within authorized frequency block (Part 24, 27)		PASS	Section 7.8
22.913(a.2)	Effective Radiated Power (Band 26)	< 7 Watts max. ERP	RADIATED	PASS	Section 7.6
24.232(c) 27.50(h.2)	Equivalent Isotropic Radiated Power (Band 25, 41)	< 2 Watts max. EIRP		PASS	Section 7.6
2.1053 22.917(a) 24.238(a)	Undesirable Emissions	> 43 + 10log <sub>10</sub> (P[Watts]) for all out-of-band emissions		PASS	Section 0
27.53(m)	Undesirable Emissions	> 43 + 10log <sub>10</sub> (P[Watts]) at channel edges > 55 + 10log <sub>10</sub> (P[Watts]) at 5.5MHz away and beyond channel edges		PASS	Section 0

**Table 7-1. Summary of Test Results**

**Notes:**

- All modes of operation and data rates were investigated. The test results shown in the following sections represent the worst case emissions.
- The analyzer plots (Sections 7.2, 7.3, 7.4, 7.5) were all taken with a correction table loaded into the analyzer. The correction table was used to account for the losses of the cables, directional couplers, and attenuators used as part of the system to maintain a link between the call box and the EUT at all frequencies of interest.
- All antenna port conducted emissions testing was performed on a test bench with the antenna port of the EUT connected to the spectrum analyzer through calibrated cables, attenuators, and couplers.
- For conducted spurious emissions, automated test software was used to measure emissions and capture the corresponding plots necessary to show compliance. The measurement software utilized is PCTEST "LTE Automation," Version 4.0.

FCC ID: ZNFLS675		FCC Pt. 22, 24, & 27 LTE MEASUREMENT REPORT (CERTIFICATION)		Reviewed by: Quality Manager
Test Report S/N: 0Y1511161951.ZNF	Test Dates: 10/12-10/16/2015, 11/17 - 11/27/2015	EUT Type: Portable Handset	Page 13 of 110	

## 7.2 Occupied Bandwidth

### §2.1049

#### Test Overview

The occupied bandwidth, that is the frequency bandwidth such that, below its lower and above its upper frequency limits, the mean powers radiated are each equal to 0.5 percent of the total mean power radiated by a given emission shall be measured. All modes of operation were investigated and the worst case configuration results are reported in this section.

#### Test Procedure Used

KDB 971168 D01 v02r02 – Section 4.2

#### Test Settings

1. The signal analyzer's automatic bandwidth measurement capability was used to perform the 99% occupied bandwidth and the 26dB bandwidth. The bandwidth measurement was not influenced by any intermediate power nulls in the fundamental emission.
2. RBW = 1 – 5% of the expected OBW
3. VBW  $\geq$  3 x RBW
4. Detector = Peak
5. Trace mode = max hold
6. Sweep = auto couple
7. The trace was allowed to stabilize
8. If necessary, steps 2 – 7 were repeated after changing the RBW such that it would be within 1 – 5% of the 99% occupied bandwidth observed in Step 7

#### Test Setup

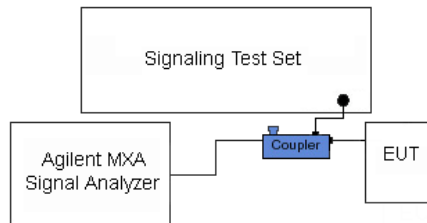

The EUT and measurement equipment were set up as shown in the diagram below.

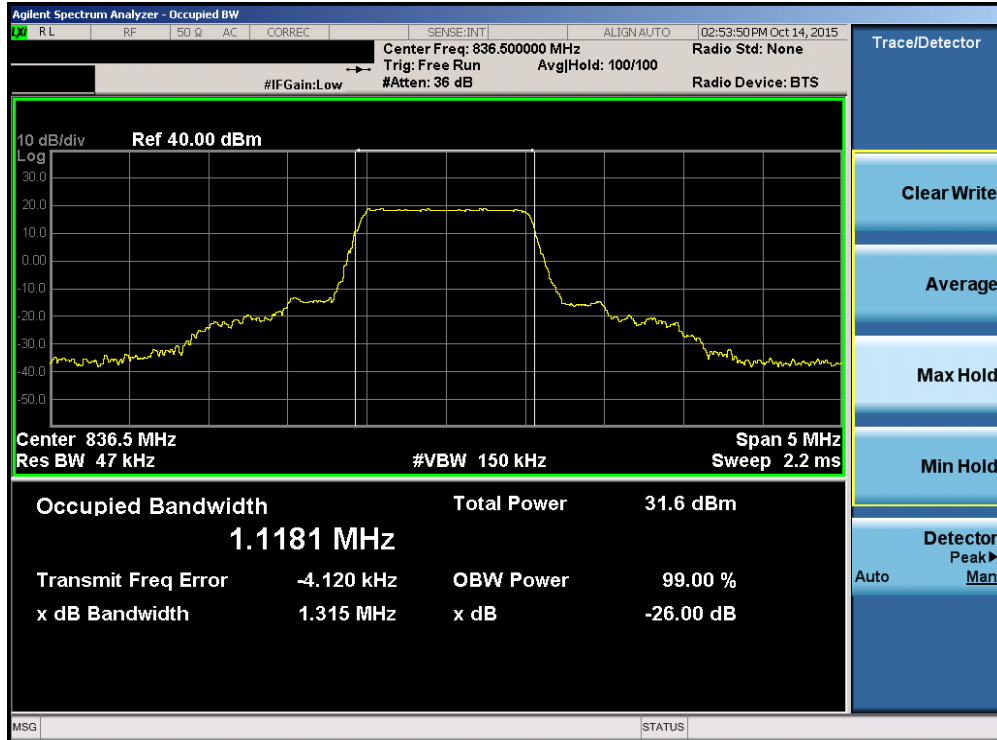

**Figure 7-1. Test Instrument & Measurement Setup**

#### Test Notes

None.

FCC ID: ZNFLS675		FCC Pt. 22, 24, & 27 LTE MEASUREMENT REPORT (CERTIFICATION)		Reviewed by: Quality Manager
Test Report S/N: 0Y1511161951.ZNF	Test Dates: 10/12-10/16/2015, 11/17 - 11/27/2015	EUT Type: Portable Handset		Page 14 of 110



Plot 7-1. Occupied Bandwidth Plot (Band 26 – 1.4MHz QPSK – RB Size 6)

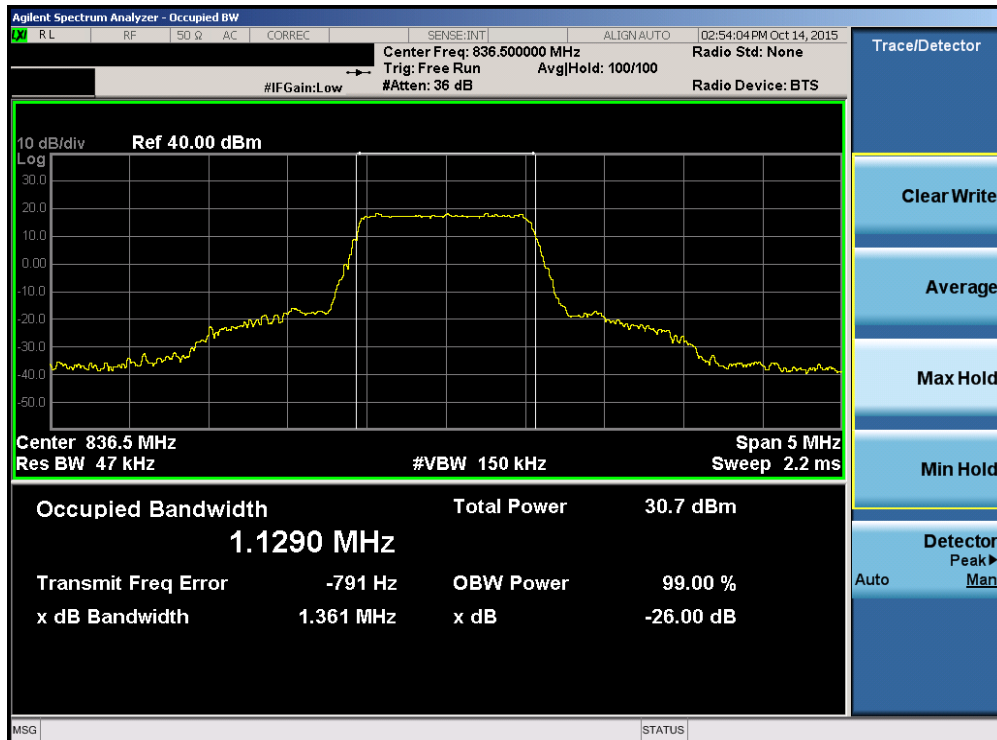

Plot 7-2. Occupied Bandwidth Plot (Band 26 – 1.4MHz 16-QAM – RB Size 6)

FCC ID: ZNFLS675		FCC Pt. 22, 24, & 27 LTE MEASUREMENT REPORT (CERTIFICATION)		Reviewed by: Quality Manager
Test Report S/N: 0Y1511161951.ZNF	Test Dates: 10/12-10/16/2015, 11/17 - 11/27/2015	EUT Type: Portable Handset		Page 15 of 110

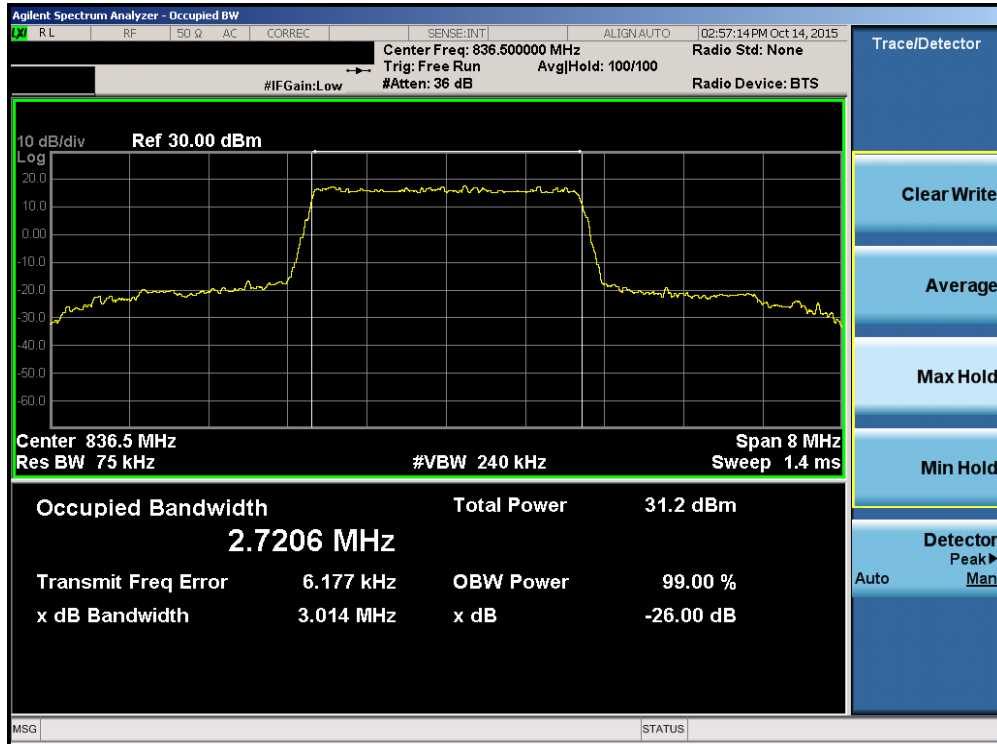

Plot 7-3. Occupied Bandwidth Plot (Band 26 – 3.0MHz QPSK – RB Size 15)

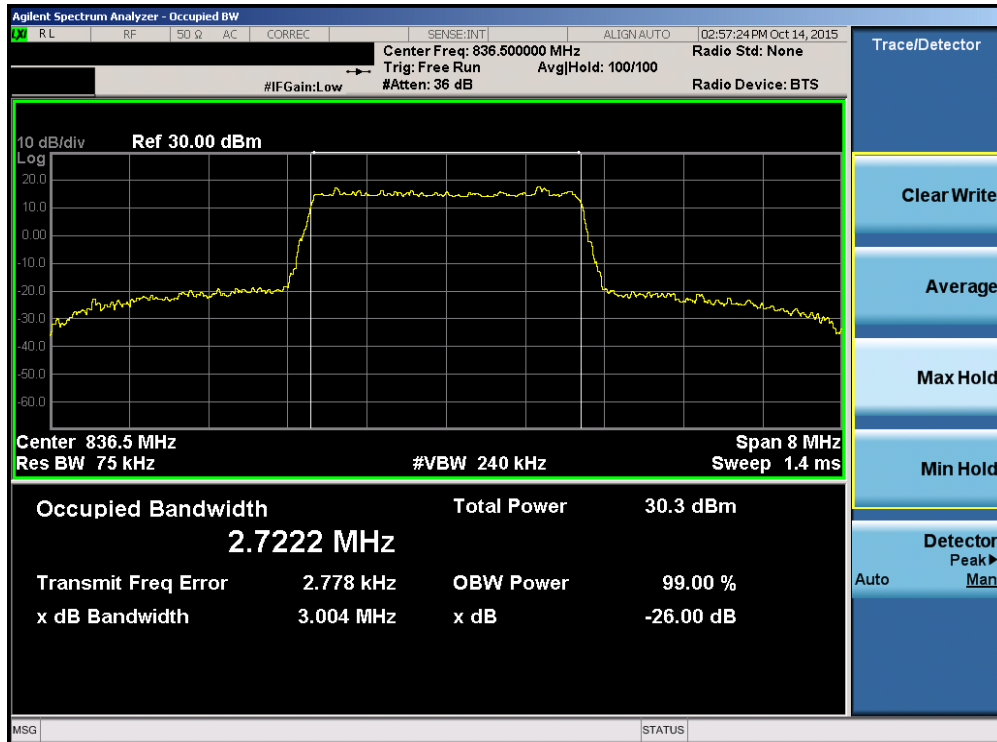

Plot 7-4. Occupied Bandwidth Plot (Band 26 – 3.0MHz 16-QAM – RB Size 15)

FCC ID: ZNFLS675		FCC Pt. 22, 24, & 27 LTE MEASUREMENT REPORT (CERTIFICATION)		Reviewed by: Quality Manager
Test Report S/N: 0Y1511161951.ZNF	Test Dates: 10/12-10/16/2015, 11/17 - 11/27/2015	EUT Type: Portable Handset		Page 16 of 110



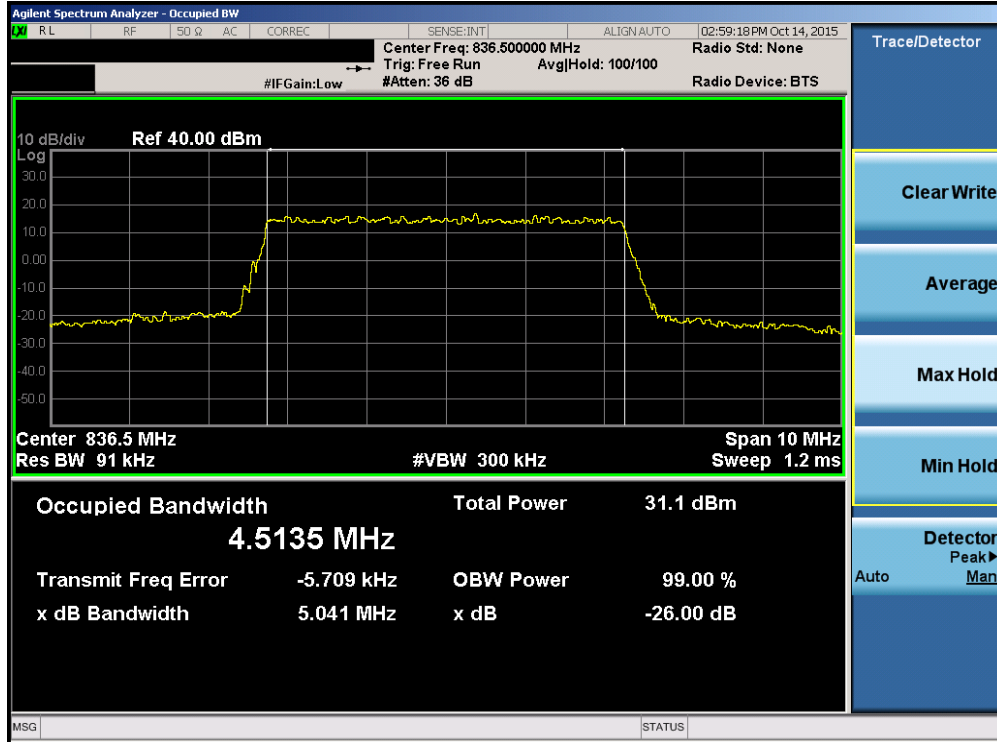

Plot 7-5. Occupied Bandwidth Plot (Band 26 – 5.0MHz QPSK – RB Size 25)

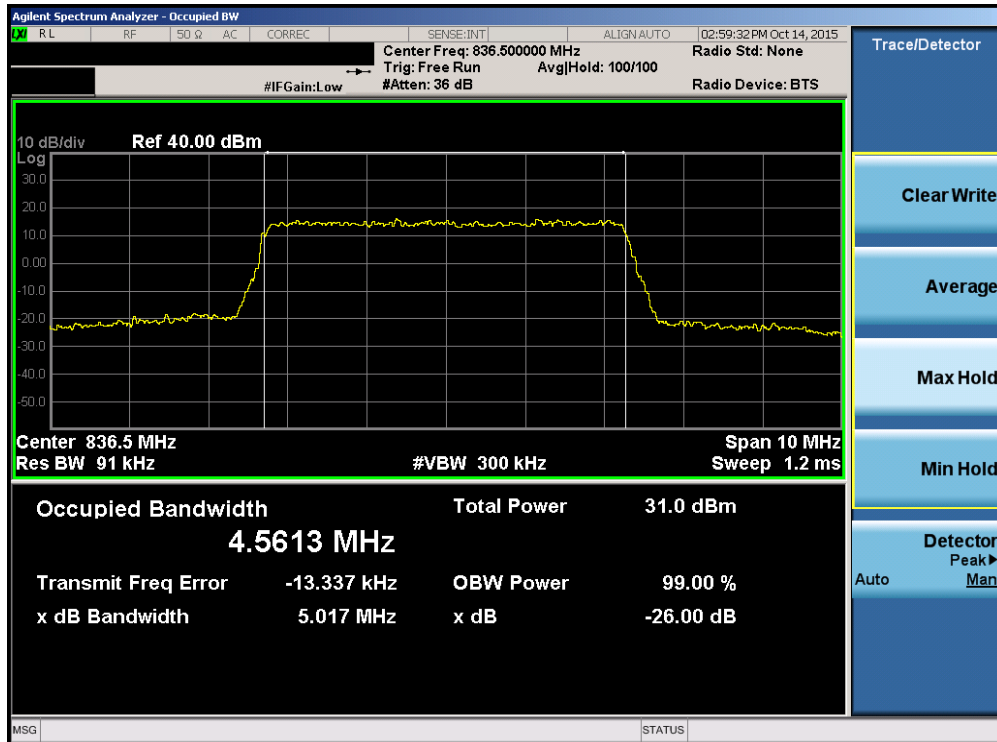

Plot 7-6. Occupied Bandwidth Plot (Band 26 – 5.0MHz 16-QAM – RB Size 25)

FCC ID: ZNFLS675		FCC Pt. 22, 24, & 27 LTE MEASUREMENT REPORT (CERTIFICATION)		Reviewed by: Quality Manager
Test Report S/N: 0Y1511161951.ZNF	Test Dates: 10/12-10/16/2015, 11/17 - 11/27/2015	EUT Type: Portable Handset		Page 17 of 110

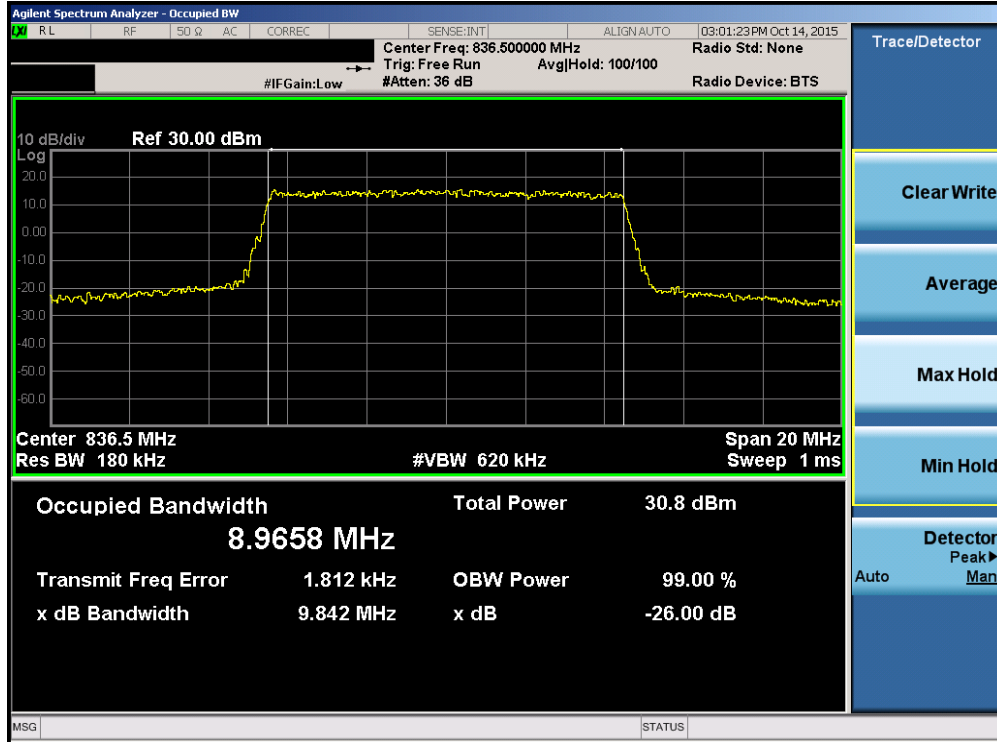

Plot 7-7. Occupied Bandwidth Plot (Band 26 – 10.0MHz QPSK – RB Size 50)

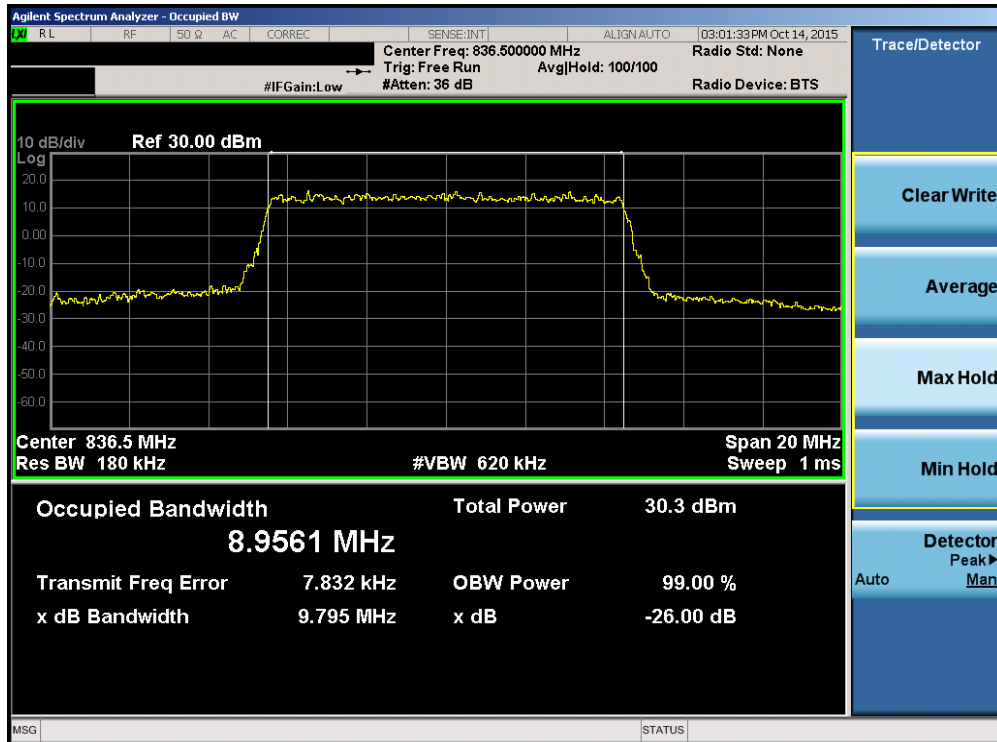

Plot 7-8. Occupied Bandwidth Plot (Band 26 – 10.0MHz 16-QAM – RB Size 50)

FCC ID: ZNFLS675		FCC Pt. 22, 24, & 27 LTE MEASUREMENT REPORT (CERTIFICATION)		Reviewed by: Quality Manager
Test Report S/N: 0Y1511161951.ZNF	Test Dates: 10/12-10/16/2015, 11/17 - 11/27/2015	EUT Type: Portable Handset		Page 18 of 110

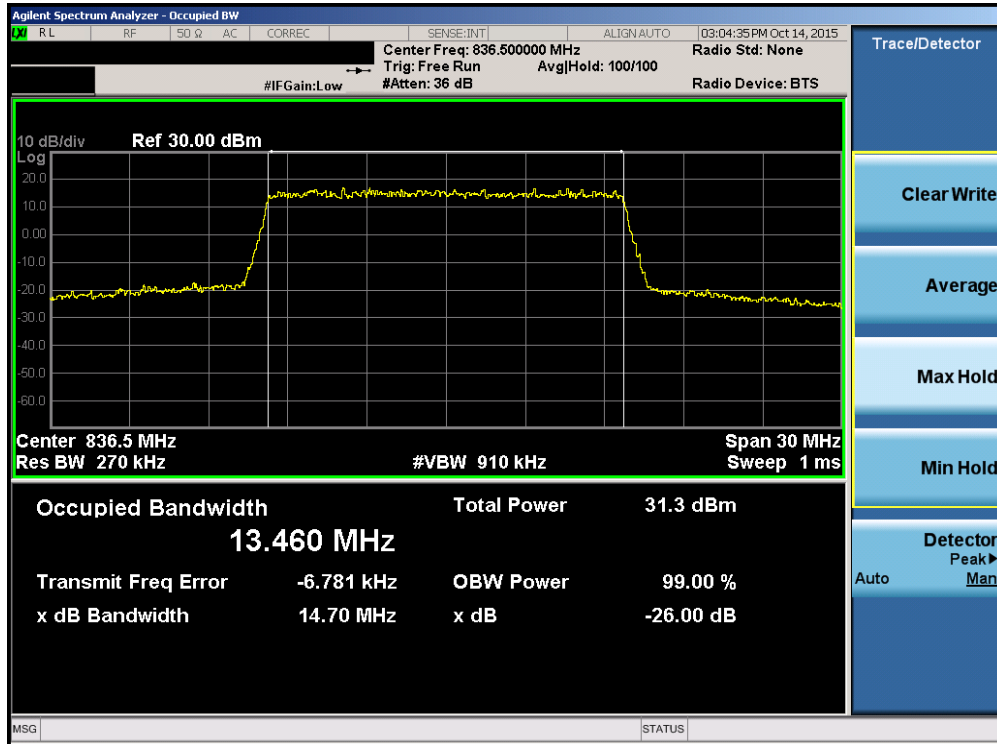

Plot 7-9. Occupied Bandwidth Plot (Band 26 – 15.0MHz QPSK – RB Size 75)

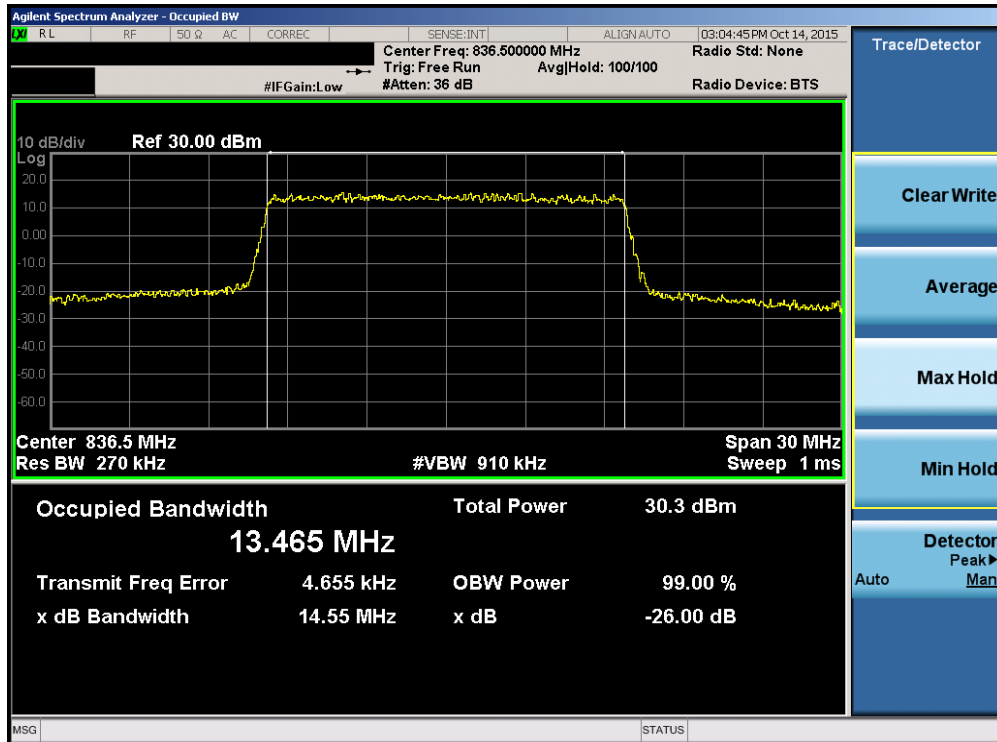

Plot 7-10. Occupied Bandwidth Plot (Band 26 – 15.0MHz 16-QAM – RB Size 75)

FCC ID: ZNFLS675		FCC Pt. 22, 24, & 27 LTE MEASUREMENT REPORT (CERTIFICATION)		Reviewed by: Quality Manager
Test Report S/N: 0Y1511161951.ZNF	Test Dates: 10/12-10/16/2015, 11/17 - 11/27/2015	EUT Type: Portable Handset		Page 19 of 110

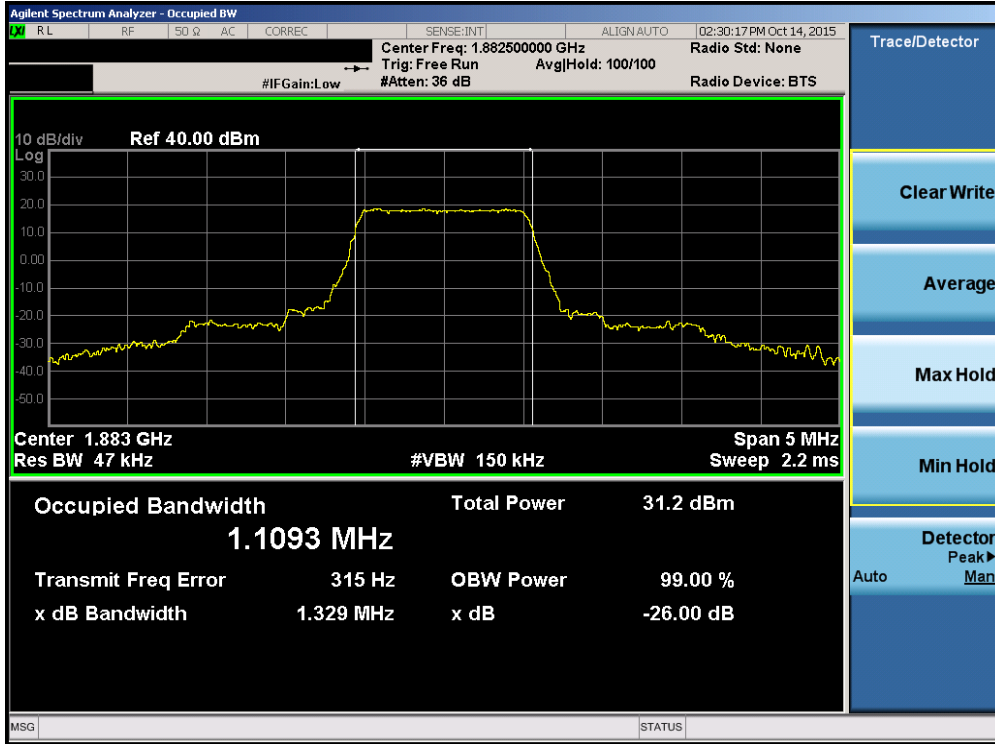

Plot 7-11. Occupied Bandwidth Plot (Band 25 – 1.4MHz QPSK – RB Size 6)

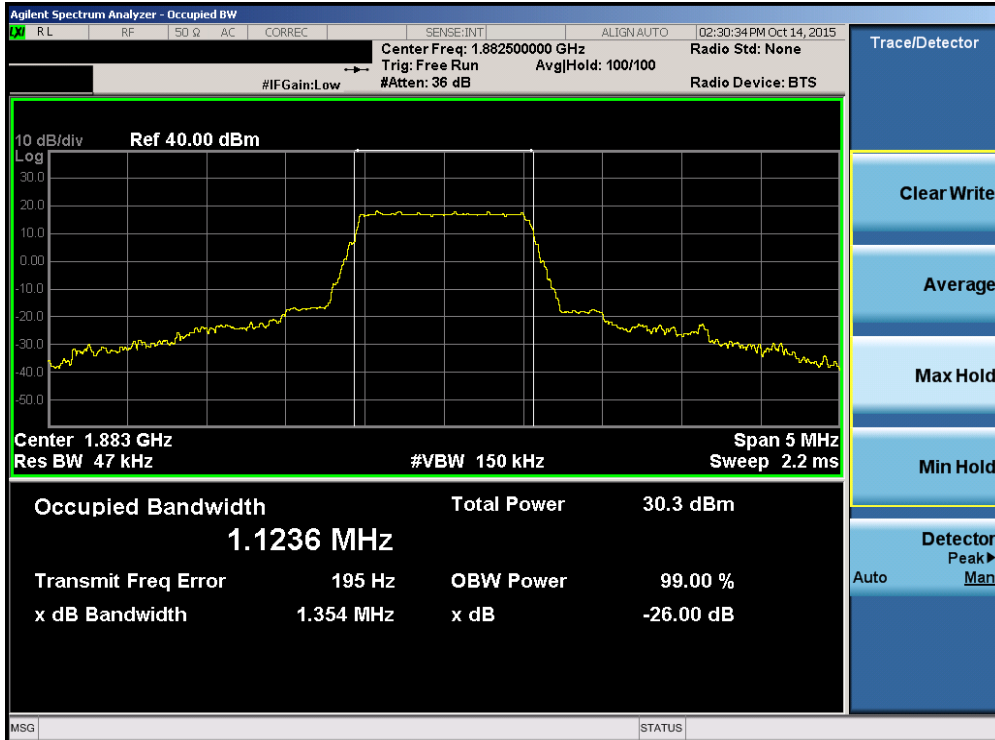

Plot 7-12. Occupied Bandwidth Plot (Band 25 – 1.4MHz 16-QAM – RB Size 6)

FCC ID: ZNFLS675		FCC Pt. 22, 24, & 27 LTE MEASUREMENT REPORT (CERTIFICATION)		Reviewed by: Quality Manager
Test Report S/N: 0Y1511161951.ZNF	Test Dates: 10/12-10/16/2015, 11/17 - 11/27/2015	EUT Type: Portable Handset		Page 20 of 110

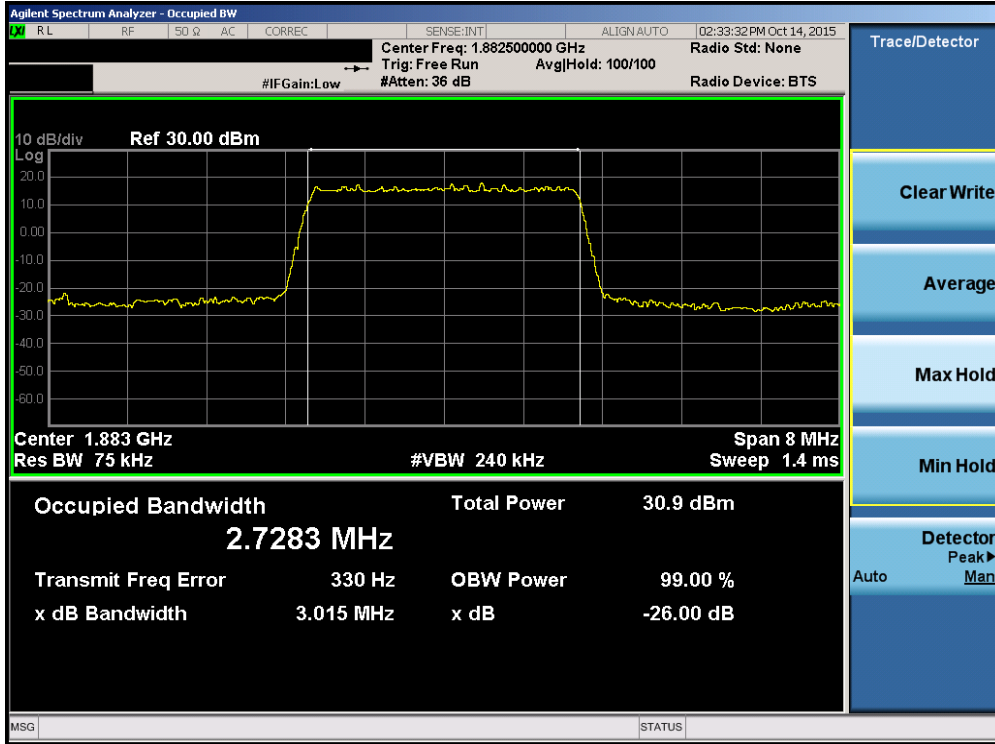

Plot 7-13. Occupied Bandwidth Plot (Band 25 – 3.0MHz QPSK – RB Size 15)

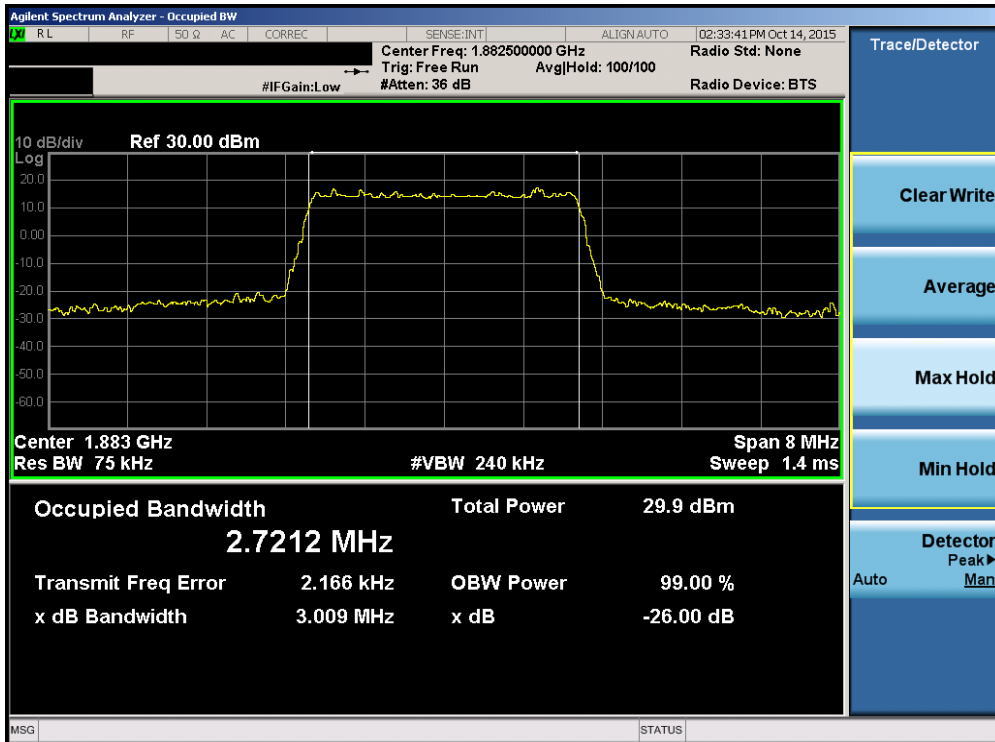

Plot 7-14. Occupied Bandwidth Plot (Band 25 – 3.0MHz 16-QAM – RB Size 15)

FCC ID: ZNFLS675		FCC Pt. 22, 24, & 27 LTE MEASUREMENT REPORT (CERTIFICATION)		Reviewed by: Quality Manager
Test Report S/N: 0Y1511161951.ZNF	Test Dates: 10/12-10/16/2015, 11/17 - 11/27/2015	EUT Type: Portable Handset		Page 21 of 110

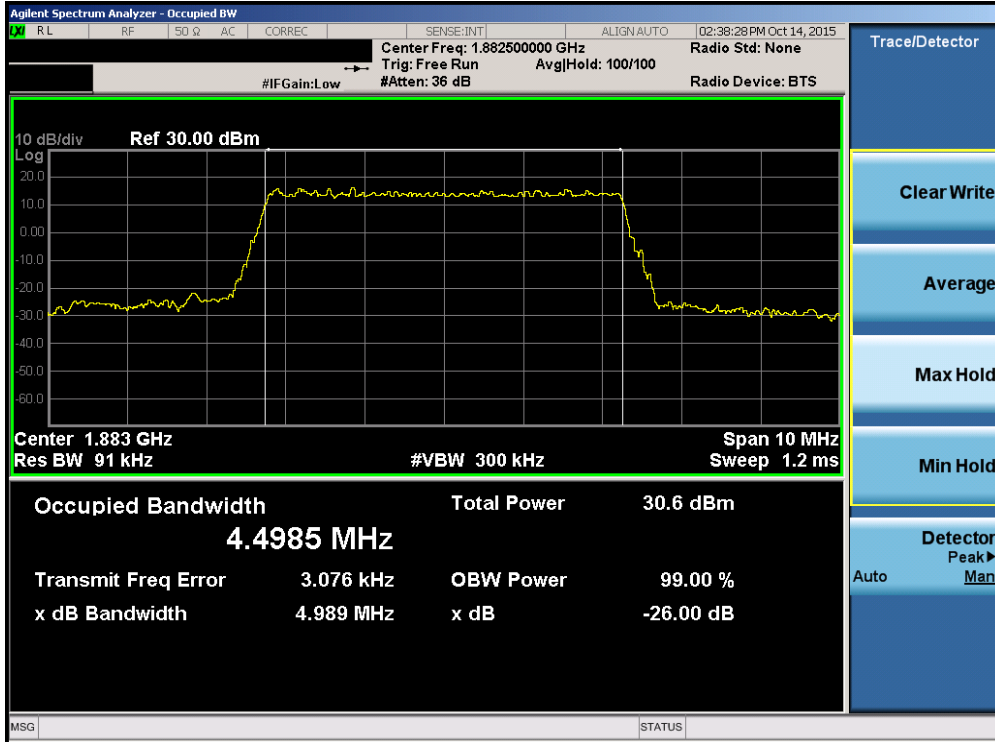

Plot 7-15. Occupied Bandwidth Plot (Band 25 – 5.0MHz QPSK – RB Size 25)

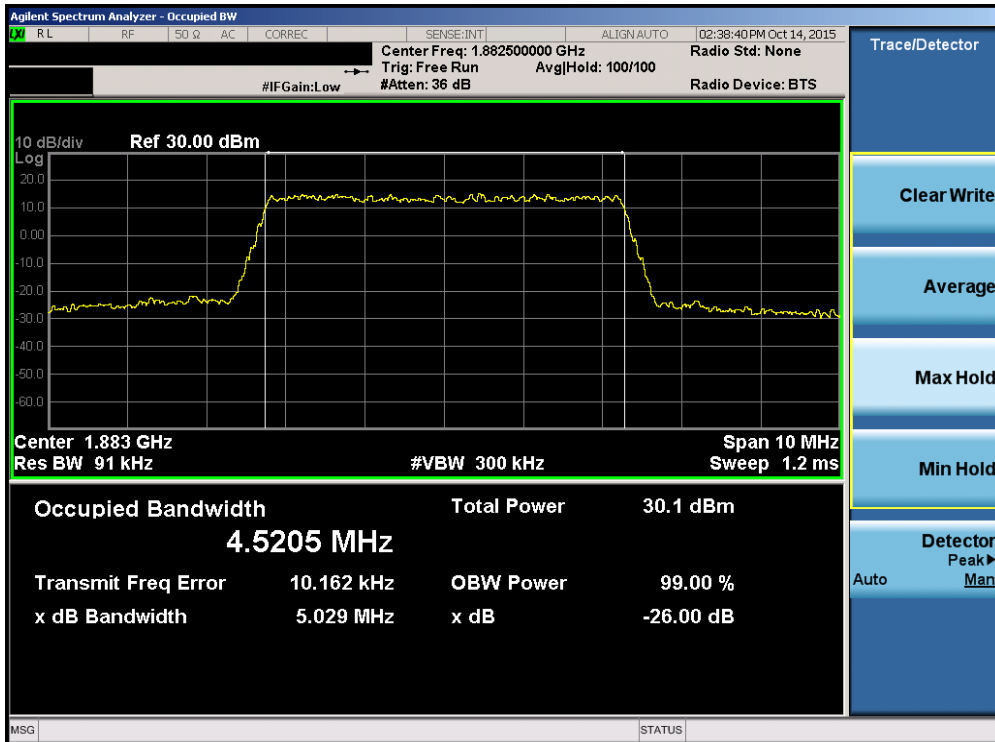

Plot 7-16. Occupied Bandwidth Plot (Band 25 – 5.0MHz 16-QAM – RB Size 25)

FCC ID: ZNFLS675		FCC Pt. 22, 24, & 27 LTE MEASUREMENT REPORT (CERTIFICATION)		Reviewed by: Quality Manager
Test Report S/N: 0Y1511161951.ZNF	Test Dates: 10/12-10/16/2015, 11/17 - 11/27/2015	EUT Type: Portable Handset		Page 22 of 110

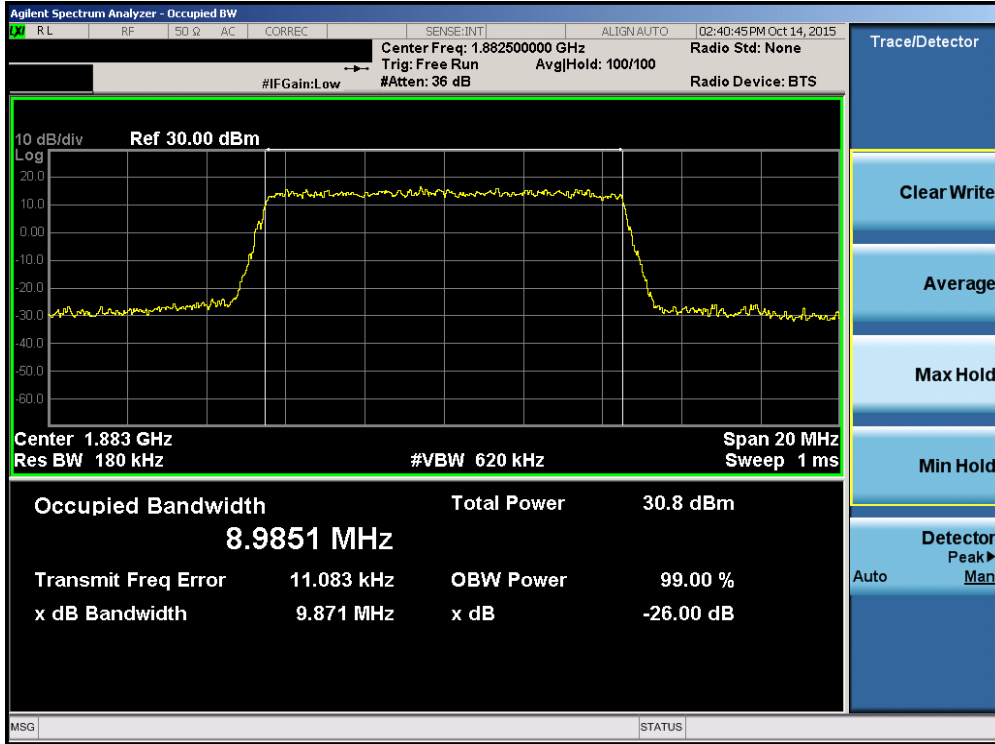

Plot 7-17. Occupied Bandwidth Plot (Band 25 – 10.0MHz QPSK – RB Size 50)

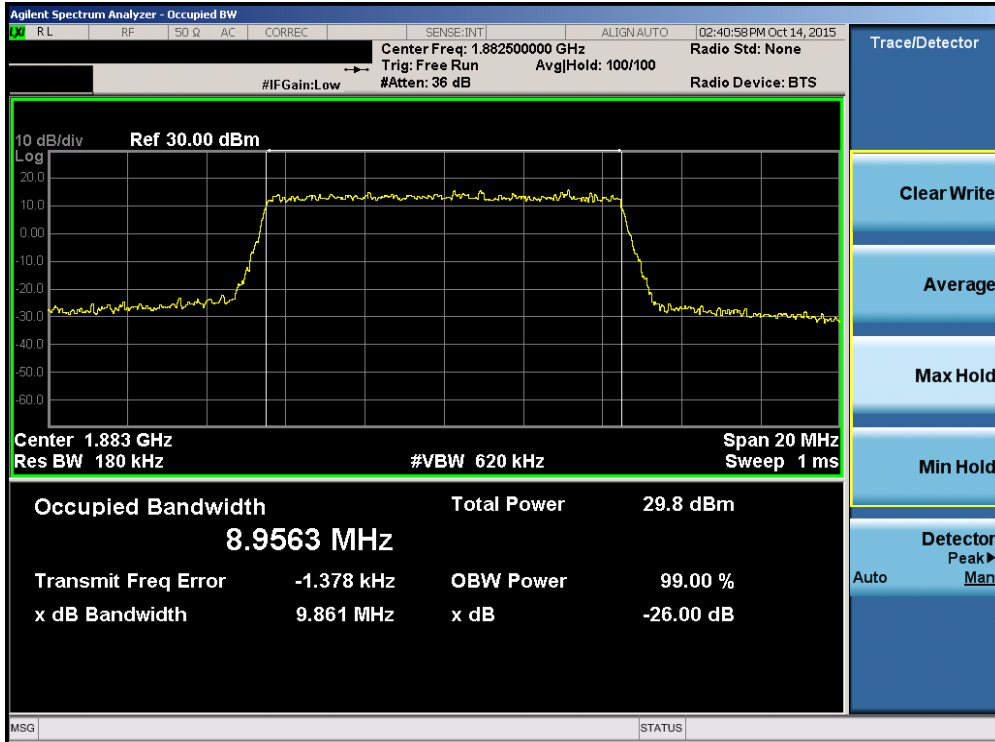

Plot 7-18. Occupied Bandwidth Plot (Band 25 – 10.0MHz 16-QAM – RB Size 50)

FCC ID: ZNFLS675		FCC Pt. 22, 24, & 27 LTE MEASUREMENT REPORT (CERTIFICATION)		Reviewed by: Quality Manager
Test Report S/N: 0Y1511161951.ZNF	Test Dates: 10/12-10/16/2015, 11/17 - 11/27/2015	EUT Type: Portable Handset		Page 23 of 110

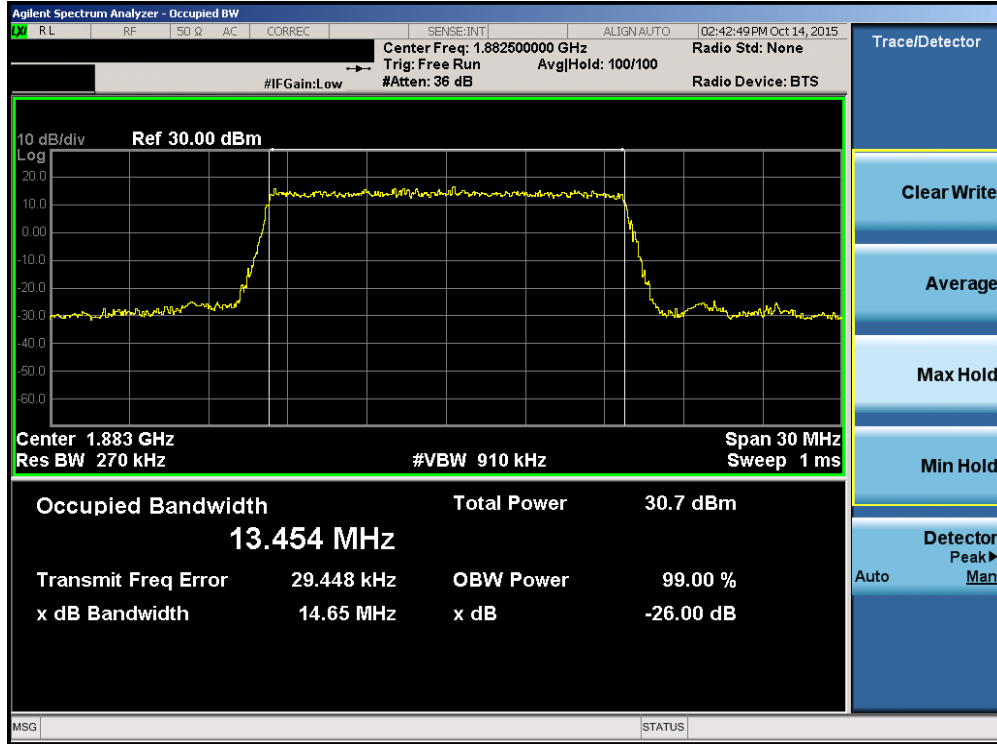

Plot 7-19. Occupied Bandwidth Plot (Band 25 – 15.0MHz QPSK – RB Size 75)

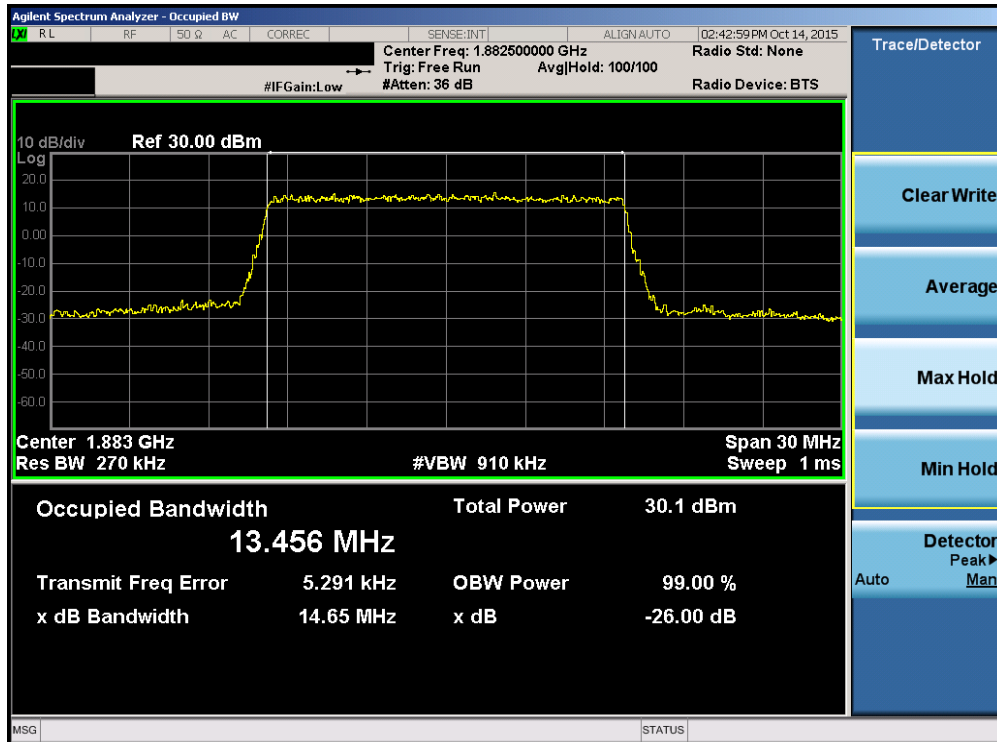

Plot 7-20. Occupied Bandwidth Plot (Band 25 – 15.0MHz 16-QAM – RB Size 75)

FCC ID: ZNFLS675		FCC Pt. 22, 24, & 27 LTE MEASUREMENT REPORT (CERTIFICATION)		Reviewed by: Quality Manager
Test Report S/N: 0Y1511161951.ZNF	Test Dates: 10/12-10/16/2015, 11/17 - 11/27/2015	EUT Type: Portable Handset		Page 24 of 110



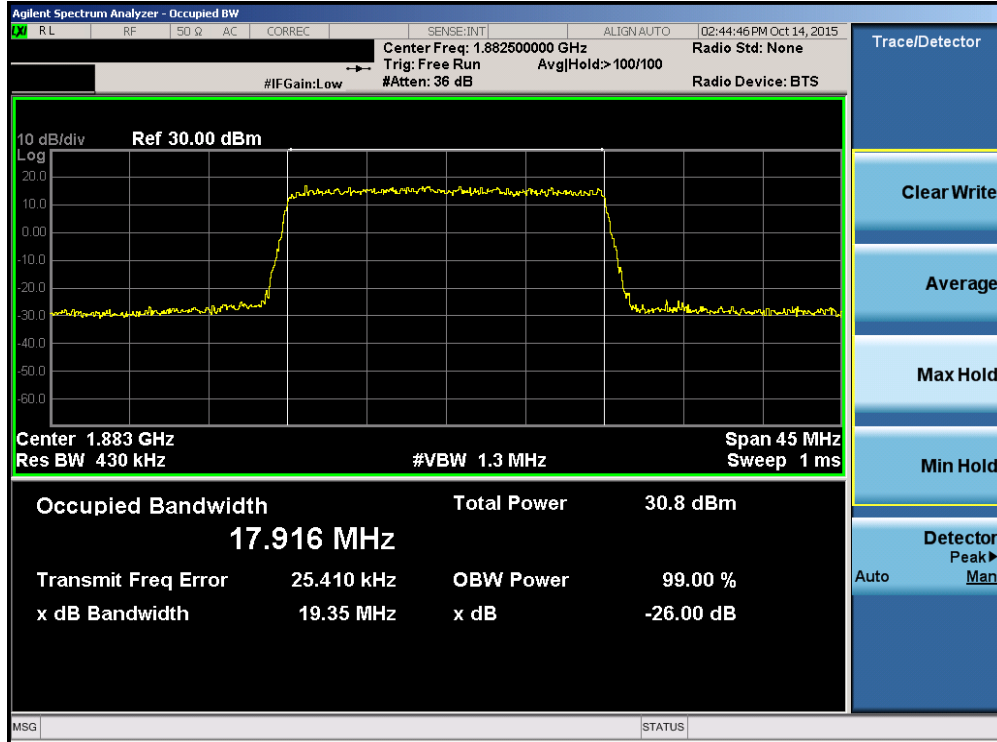

Plot 7-21. Occupied Bandwidth Plot (Band 25 – 20.0MHz QPSK – RB Size 100)

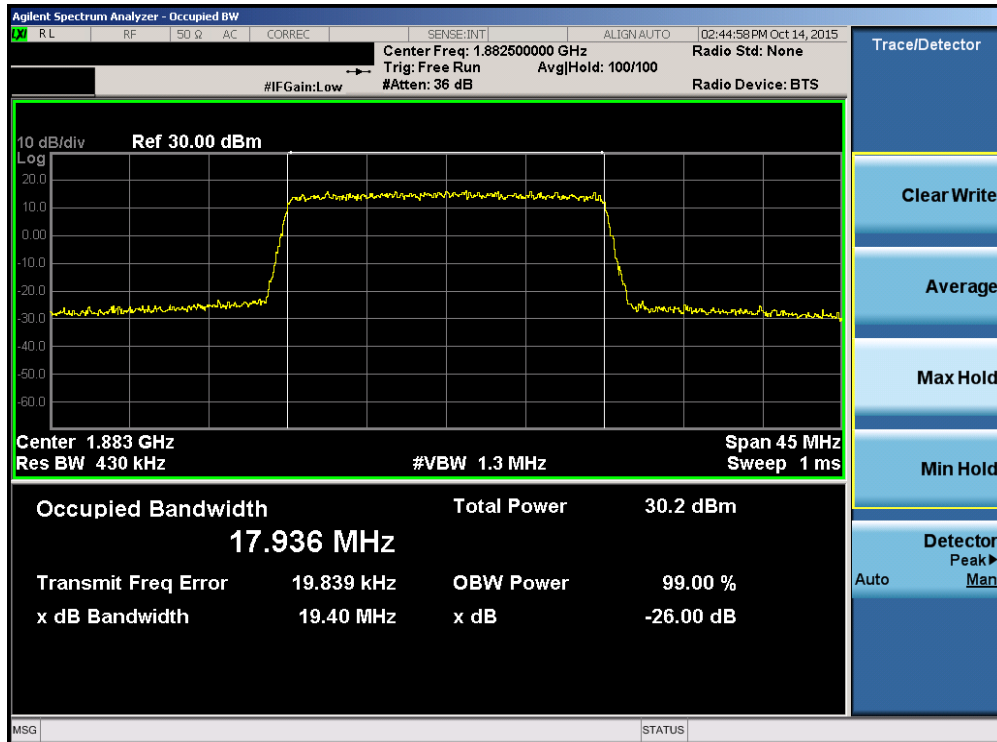

Plot 7-22. Occupied Bandwidth Plot (Band 25 – 20.0MHz 16-QAM – RB Size 100)

FCC ID: ZNFLS675		FCC Pt. 22, 24, & 27 LTE MEASUREMENT REPORT (CERTIFICATION)		Reviewed by: Quality Manager
Test Report S/N: 0Y1511161951.ZNF	Test Dates: 10/12-10/16/2015, 11/17 - 11/27/2015	EUT Type: Portable Handset		Page 25 of 110

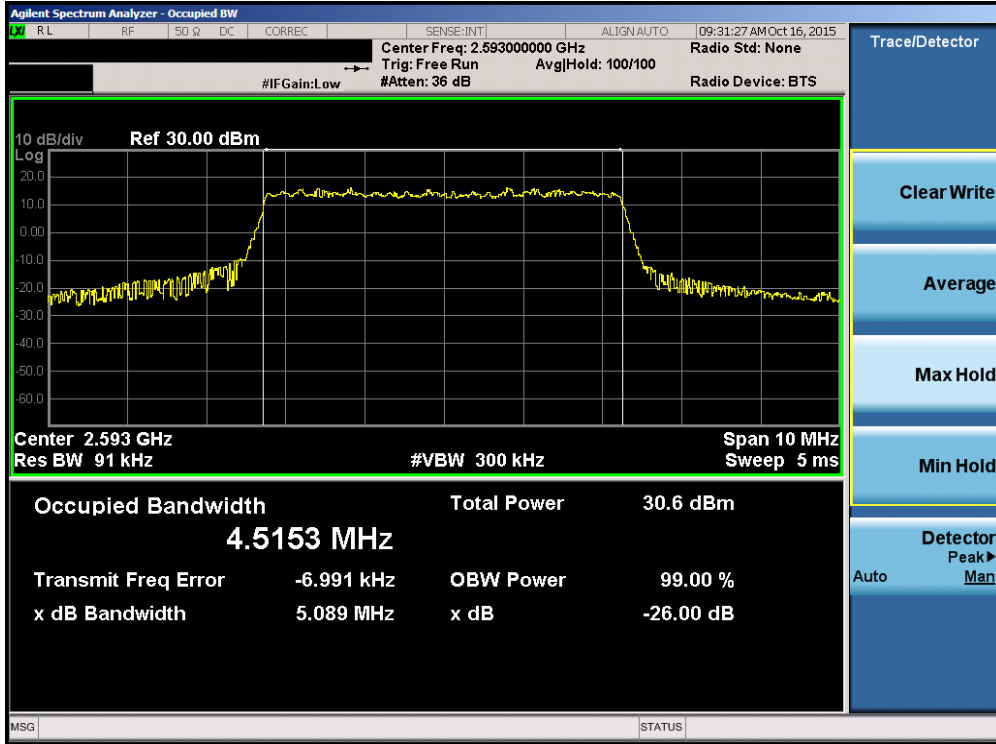

Plot 7-23. Occupied Bandwidth Plot (Band 41 – 5.0MHz QPSK – RB Size 25)

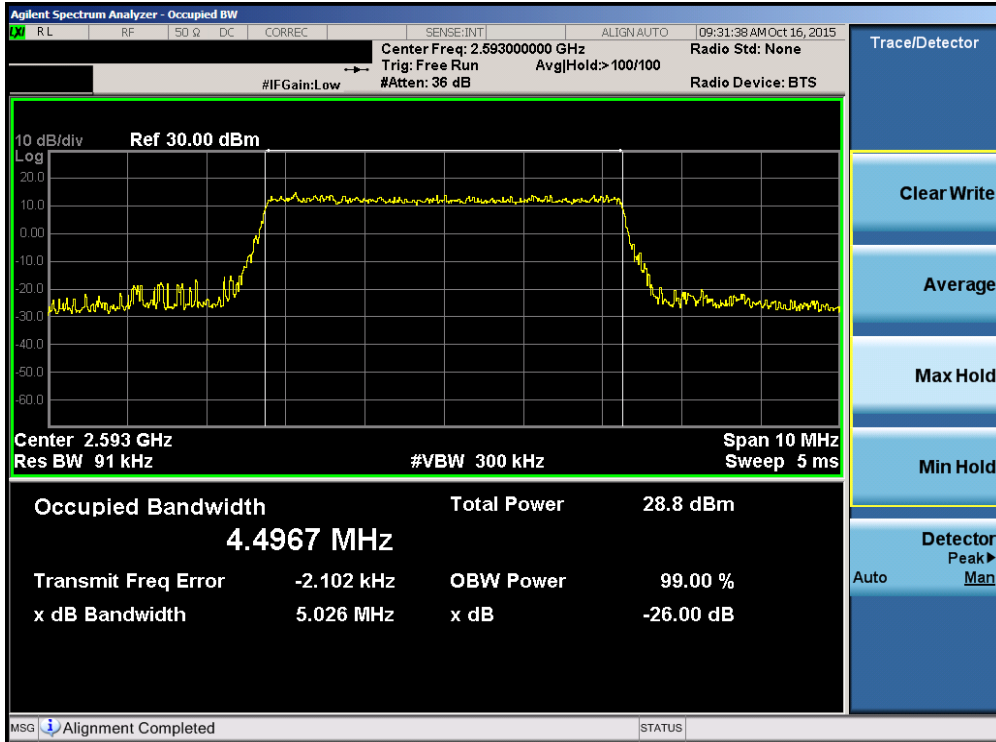

Plot 7-24. Occupied Bandwidth Plot (Band 41 – 5.0MHz 16-QAM – RB Size 25)

FCC ID: ZNFLS675		FCC Pt. 22, 24, & 27 LTE MEASUREMENT REPORT (CERTIFICATION)		Reviewed by: Quality Manager
Test Report S/N: 0Y1511161951.ZNF	Test Dates: 10/12-10/16/2015, 11/17 - 11/27/2015	EUT Type: Portable Handset		Page 26 of 110

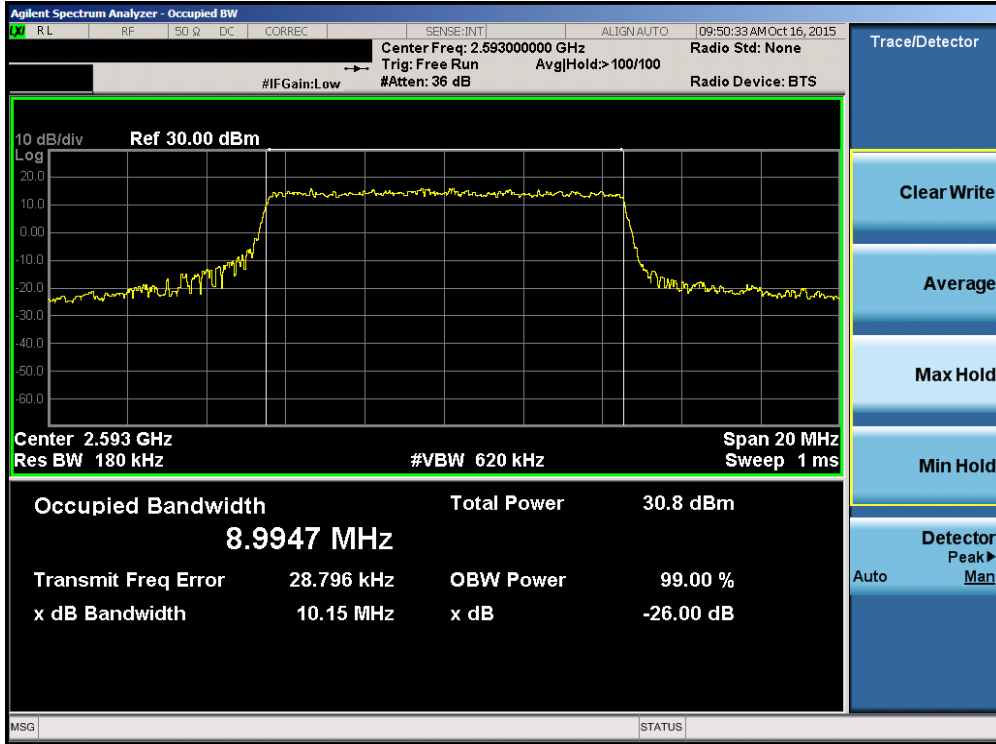

Plot 7-25. Occupied Bandwidth Plot (Band 41 – 10.0MHz QPSK – RB Size 50)

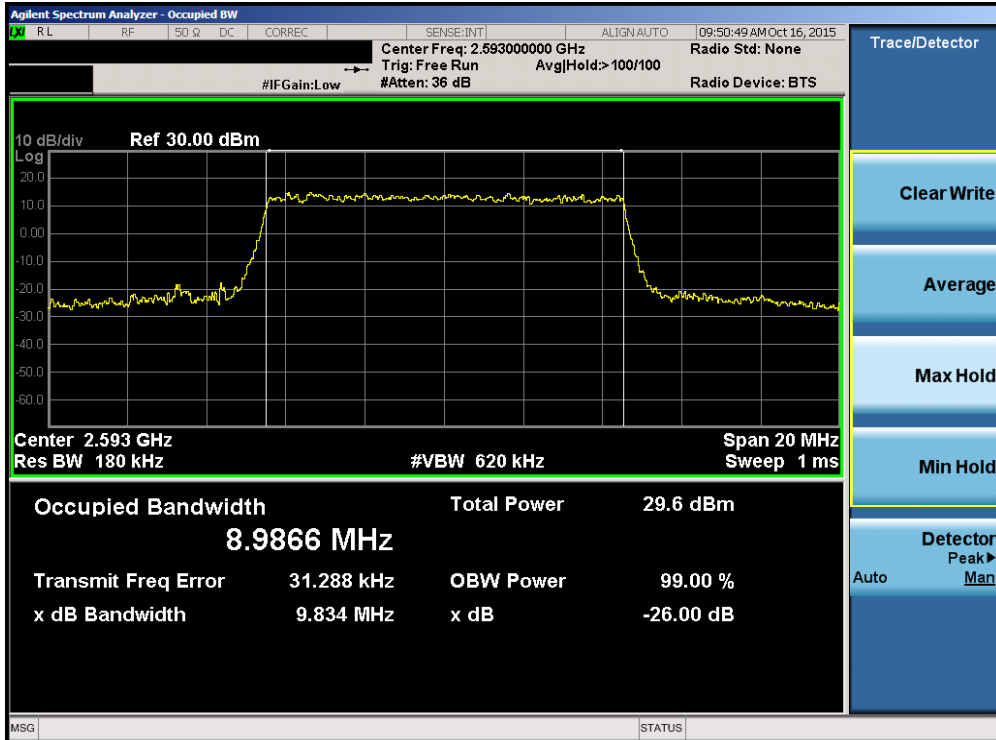

Plot 7-26. Occupied Bandwidth Plot (Band 41 – 10.0MHz 16-QAM – RB Size 50)

FCC ID: ZNFLS675		FCC Pt. 22, 24, & 27 LTE MEASUREMENT REPORT (CERTIFICATION)		Reviewed by: Quality Manager
Test Report S/N: 0Y1511161951.ZNF	Test Dates: 10/12-10/16/2015, 11/17 - 11/27/2015	EUT Type: Portable Handset		Page 27 of 110

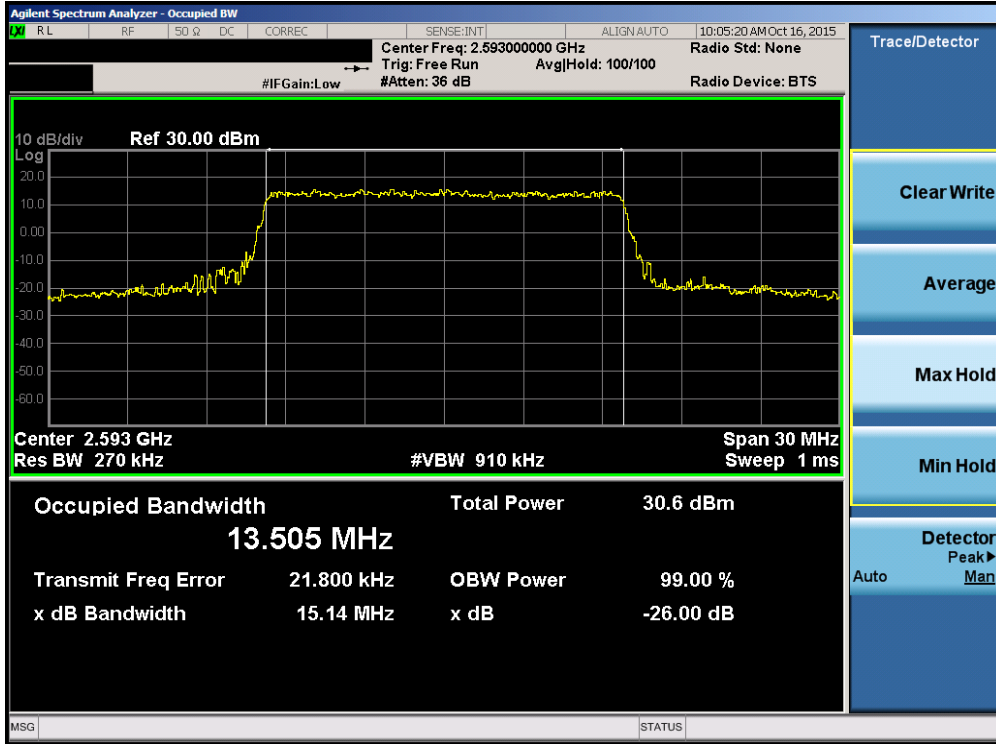

Plot 7-27. Occupied Bandwidth Plot (Band 41 – 15.0MHz QPSK – RB Size 75)

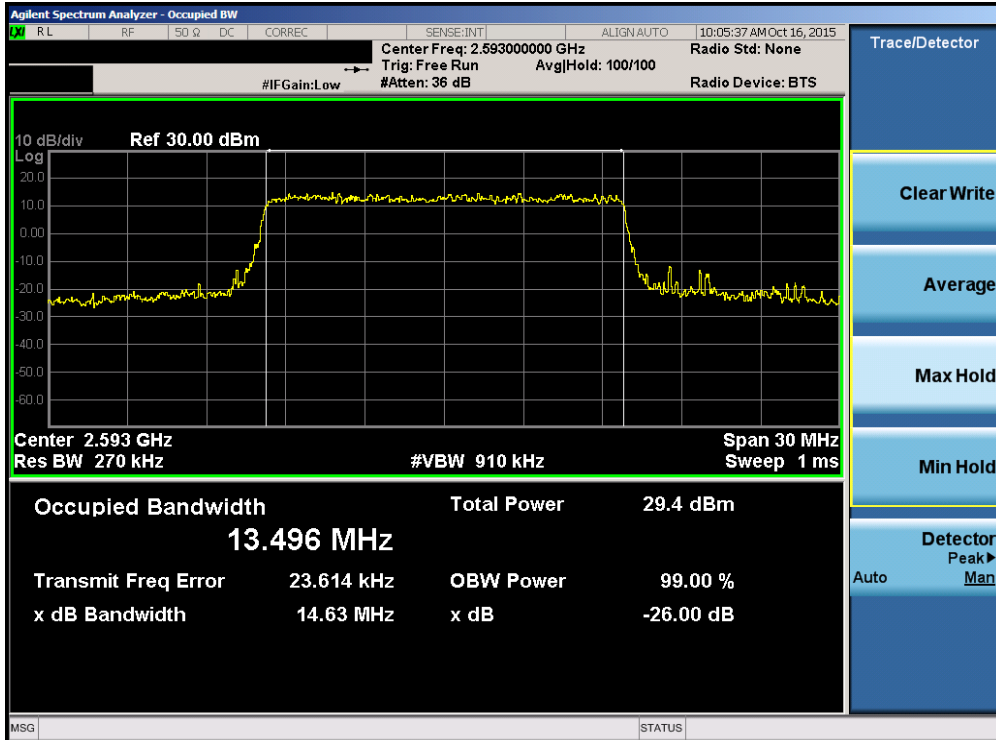

Plot 7-28. Occupied Bandwidth Plot (Band 41 – 15.0MHz 16-QAM – RB Size 75)

FCC ID: ZNFLS675		FCC Pt. 22, 24, & 27 LTE MEASUREMENT REPORT (CERTIFICATION)		Reviewed by: Quality Manager
Test Report S/N: 0Y1511161951.ZNF	Test Dates: 10/12-10/16/2015, 11/17 - 11/27/2015	EUT Type: Portable Handset		Page 28 of 110

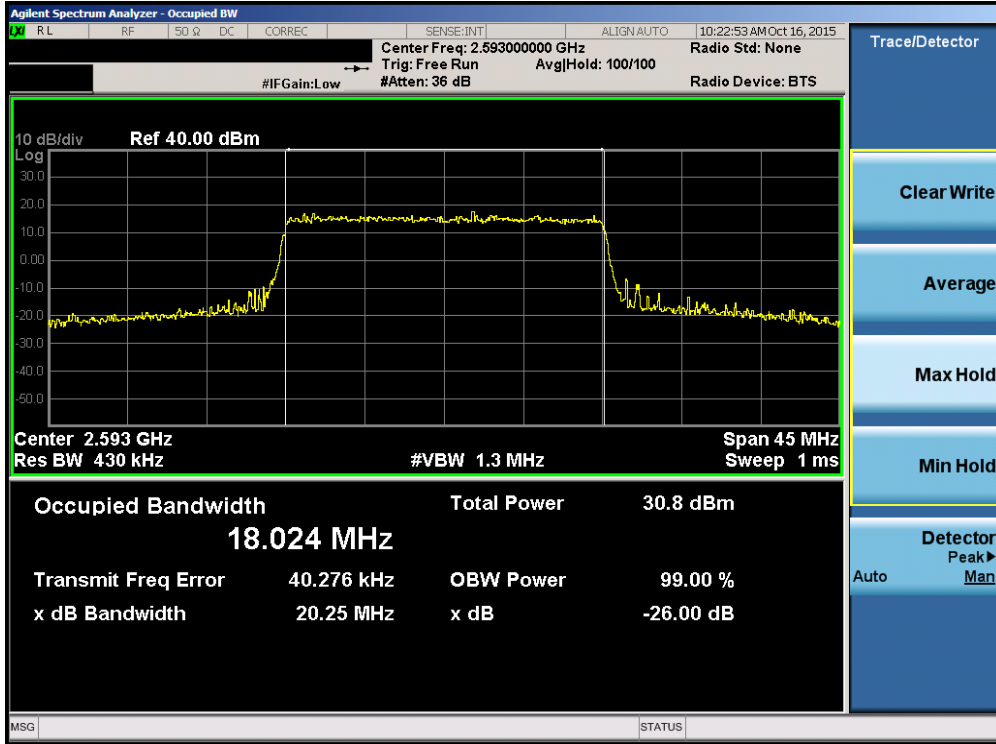

Plot 7-29. Occupied Bandwidth Plot (Band 41 – 20.0MHz QPSK – RB Size 100)

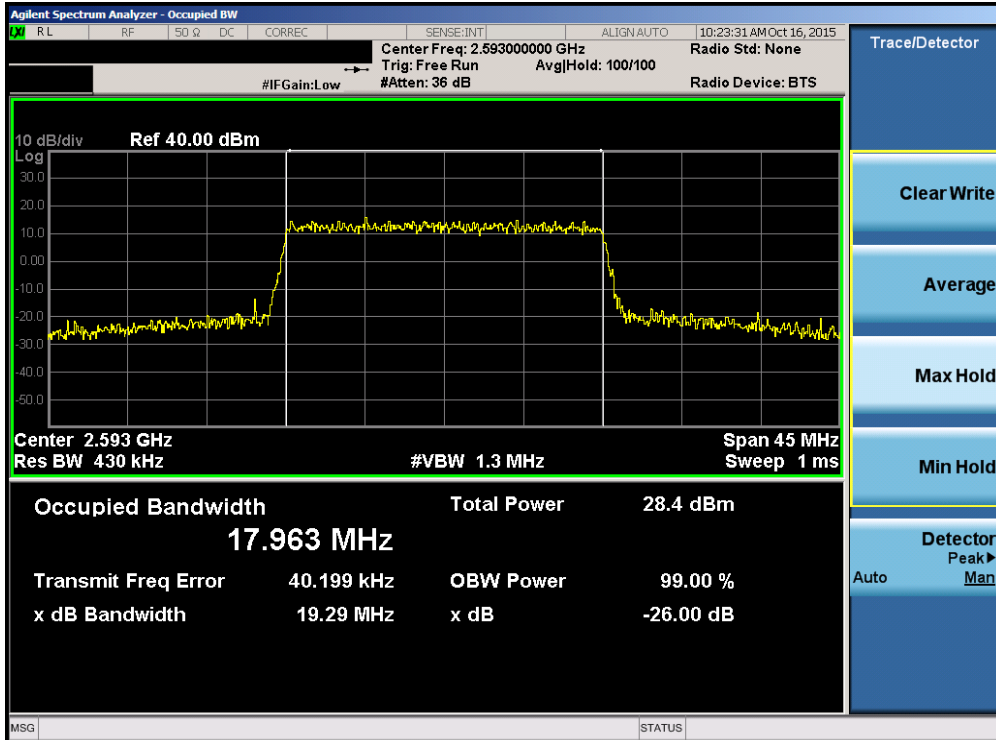

Plot 7-30. Occupied Bandwidth Plot (Band 41 – 20.0MHz 16-QAM – RB Size 100)

FCC ID: ZNFLS675		FCC Pt. 22, 24, & 27 LTE MEASUREMENT REPORT (CERTIFICATION)		Reviewed by: Quality Manager
Test Report S/N: 0Y1511161951.ZNF	Test Dates: 10/12-10/16/2015, 11/17 - 11/27/2015	EUT Type: Portable Handset		Page 29 of 110

### 7.3 Spurious and Harmonic Emissions at Antenna Terminal

§2.1051 §22.917(a) §24.238(a) §27.53(m)

#### Test Overview

The level of the carrier and the various conducted spurious and harmonic frequencies is measured by means of a calibrated spectrum analyzer. The spectrum is scanned from the lowest frequency generated in the equipment up to a frequency including its 10<sup>th</sup> harmonic. All out of band emissions are measured with a spectrum analyzer connected to the antenna terminal of the EUT while the EUT is operating at its maximum duty cycle, at maximum power, and at the appropriate frequencies. All data rates were investigated to determine the worst case configuration. All modes of operation were investigated and the worst case configuration results are reported in this section.

*For Band 41, the minimum permissible attenuation level of any spurious emission is 55 + log<sub>10</sub>(P<sub>[Watts]</sub>).*

*The minimum permissible attenuation level of any spurious emission is 43 + log<sub>10</sub>(P<sub>[Watts]</sub>), where P is the transmitter power in Watts.*

#### Test Procedure Used

KDB 971168 D01 v02r02 – Section 6.0

#### Test Settings

1. Start frequency was set to 30MHz and stop frequency was set to at least 10 \* the fundamental frequency (separated into at least two plots per channel)
2. Detector = RMS
3. Trace mode = trace average for continuous emissions, max hold for pulse emissions
4. Sweep time = auto couple
5. The trace was allowed to stabilize
6. Please see test notes below for RBW and VBW settings

#### Test Setup

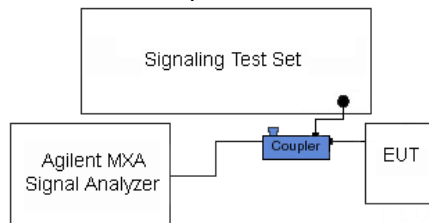

The EUT and measurement equipment were set up as shown in the diagram below.

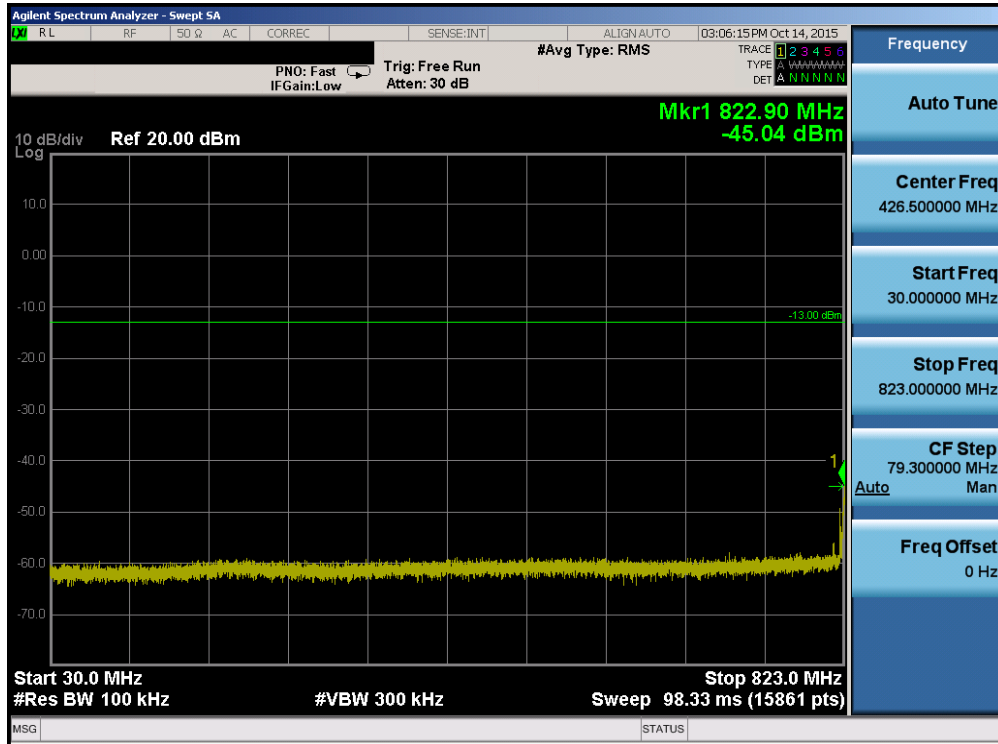

**Figure 7-2. Test Instrument & Measurement Setup**

#### Test Notes

Compliance with the applicable limits is based on the use of measurement instrumentation employing a resolution bandwidth of 100 kHz or greater for frequencies less than 1 GHz and 1 MHz or greater for frequencies greater than 1 GHz. However, in the 1 MHz bands immediately outside and adjacent to the frequency block a resolution bandwidth of at least one percent of the emission bandwidth of the fundamental emission of the transmitter may be employed. The emission bandwidth is defined as the width of the signal between two points, one below the carrier center frequency and one above the carrier center frequency, outside of which all emission are attenuated at least 26 dB below the transmitter power.

FCC ID: ZNFLS675		FCC Pt. 22, 24, & 27 LTE MEASUREMENT REPORT (CERTIFICATION)		Reviewed by: Quality Manager
Test Report S/N: 0Y1511161951.ZNF	Test Dates: 10/12-10/16/2015, 11/17 - 11/27/2015	EUT Type: Portable Handset	Page 30 of 110	



Plot 7-31. Conducted Spurious Plot (Band 26 – 15.0MHz QPSK – RB Size 1, RB Offset 0 – Low Channel)

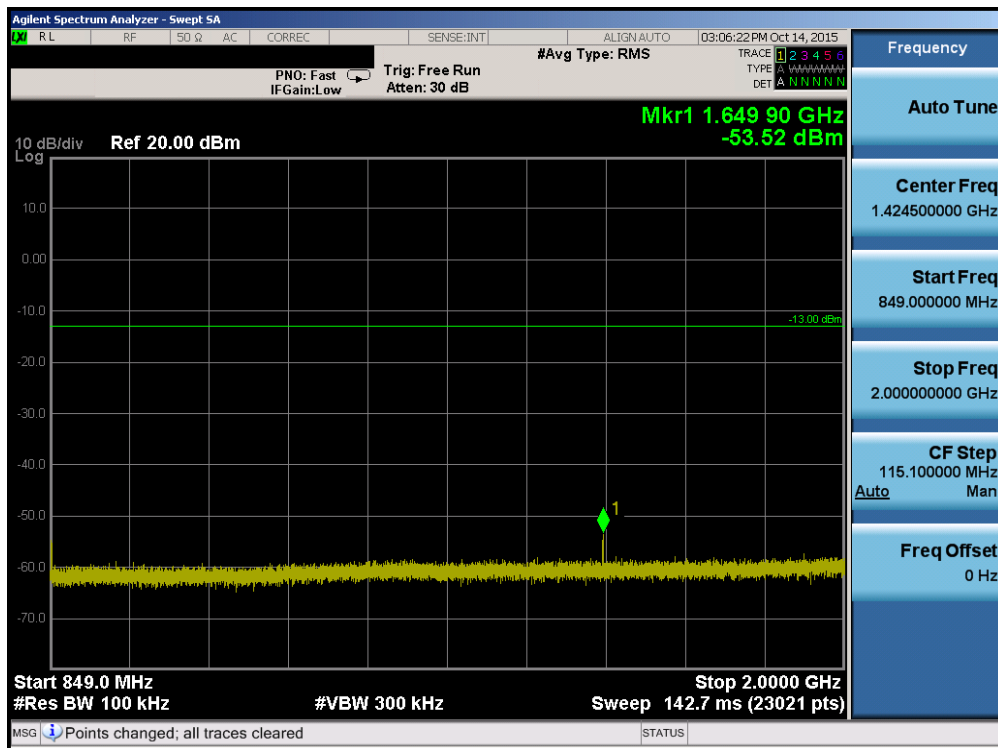

Plot 7-32. Conducted Spurious Plot (Band 26 – 15.0MHz QPSK – RB Size 1, RB Offset 0 – Low Channel)

FCC ID: ZNFLS675		FCC Pt. 22, 24, & 27 LTE MEASUREMENT REPORT (CERTIFICATION)		Reviewed by: Quality Manager
Test Report S/N: 0Y1511161951.ZNF	Test Dates: 10/12-10/16/2015, 11/17 - 11/27/2015	EUT Type: Portable Handset		Page 31 of 110

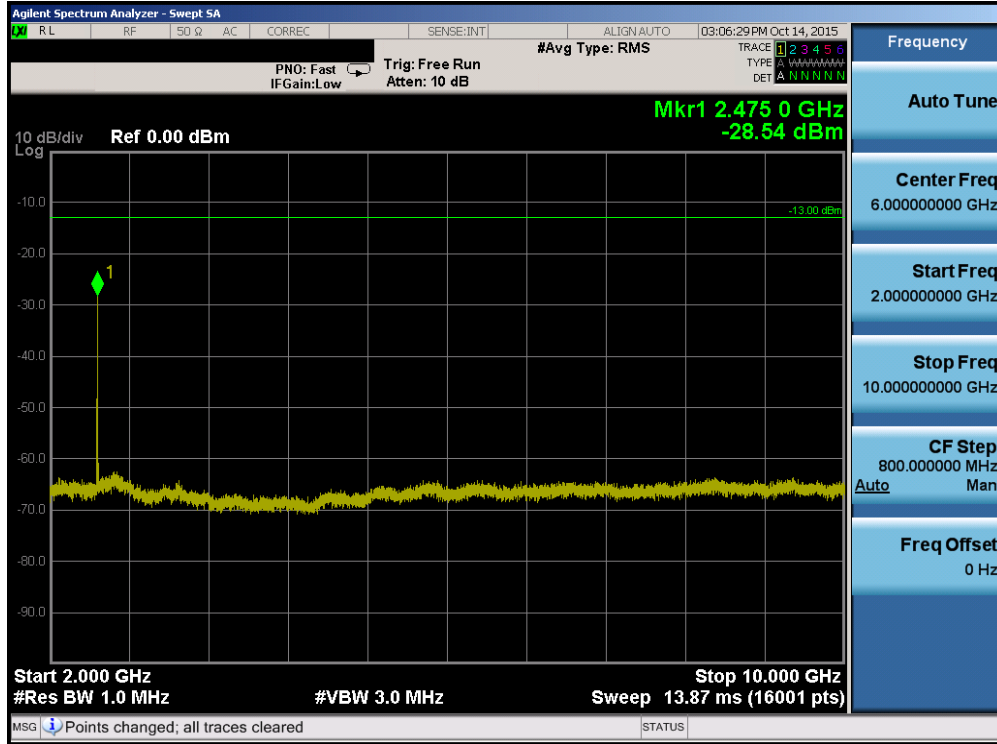

Plot 7-33. Conducted Spurious Plot (Band 26 – 15.0MHz QPSK – RB Size 1, RB Offset 0 – Low Channel)

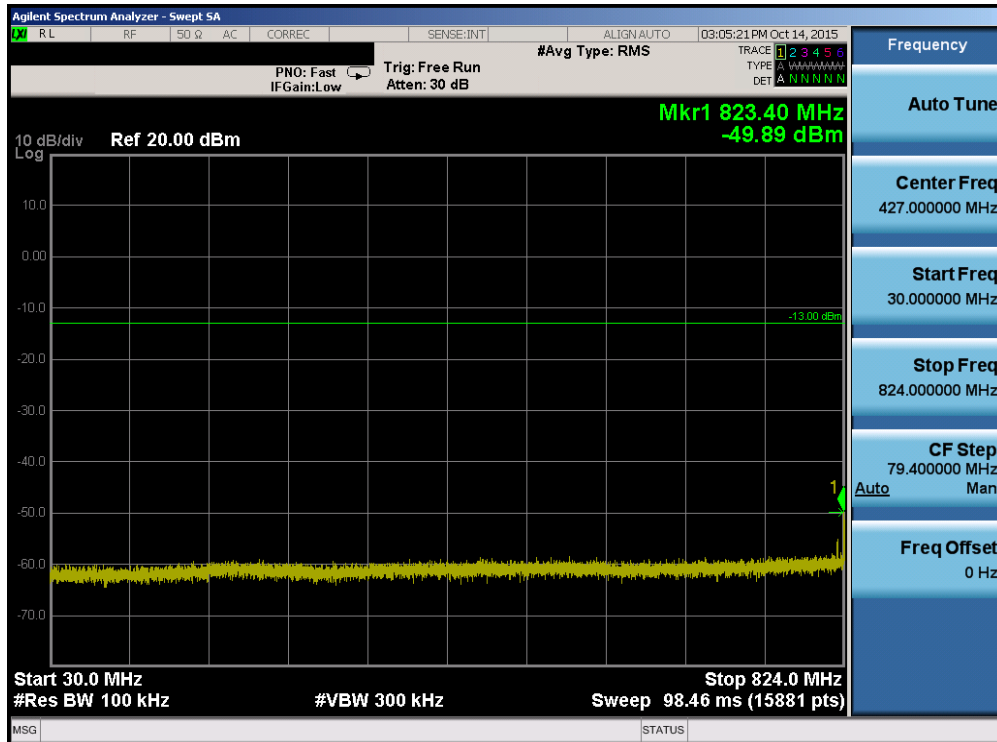

Plot 7-34. Conducted Spurious Plot (Band 26 – 15.0MHz QPSK – RB Size 1, RB Offset 0 – Mid Channel)

FCC ID: ZNFLS675		FCC Pt. 22, 24, & 27 LTE MEASUREMENT REPORT (CERTIFICATION)		Reviewed by: Quality Manager
Test Report S/N: 0Y1511161951.ZNF	Test Dates: 10/12-10/16/2015, 11/17 - 11/27/2015	EUT Type: Portable Handset		Page 32 of 110



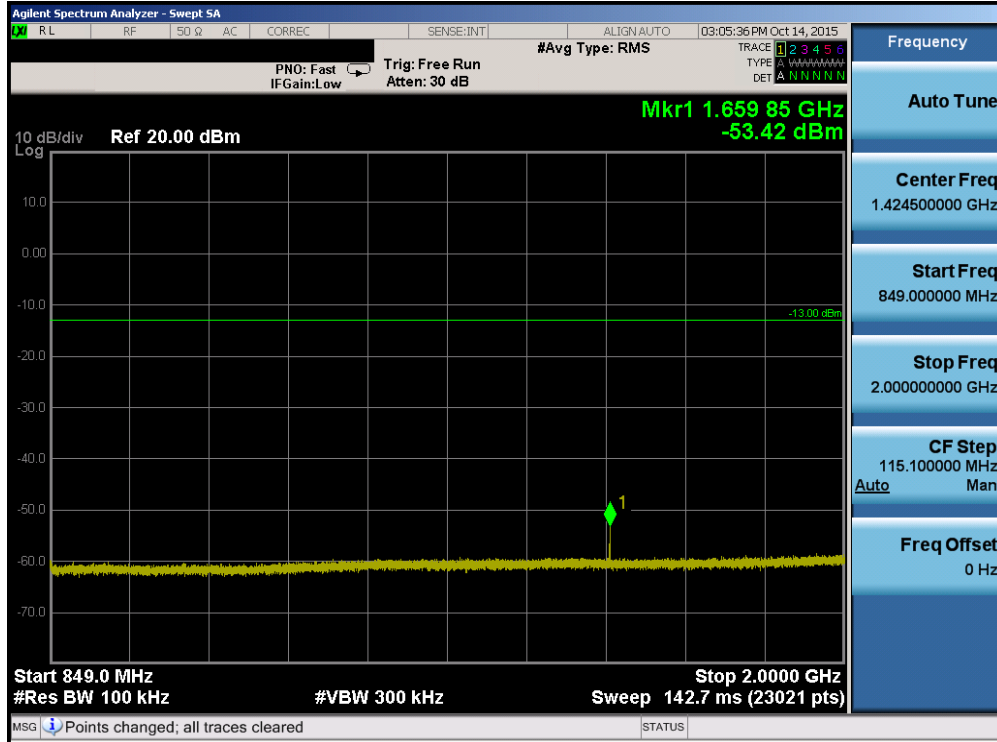

Plot 7-35. Conducted Spurious Plot (Band 26 – 15.0MHz QPSK – RB Size 1, RB Offset 0 – Mid Channel)

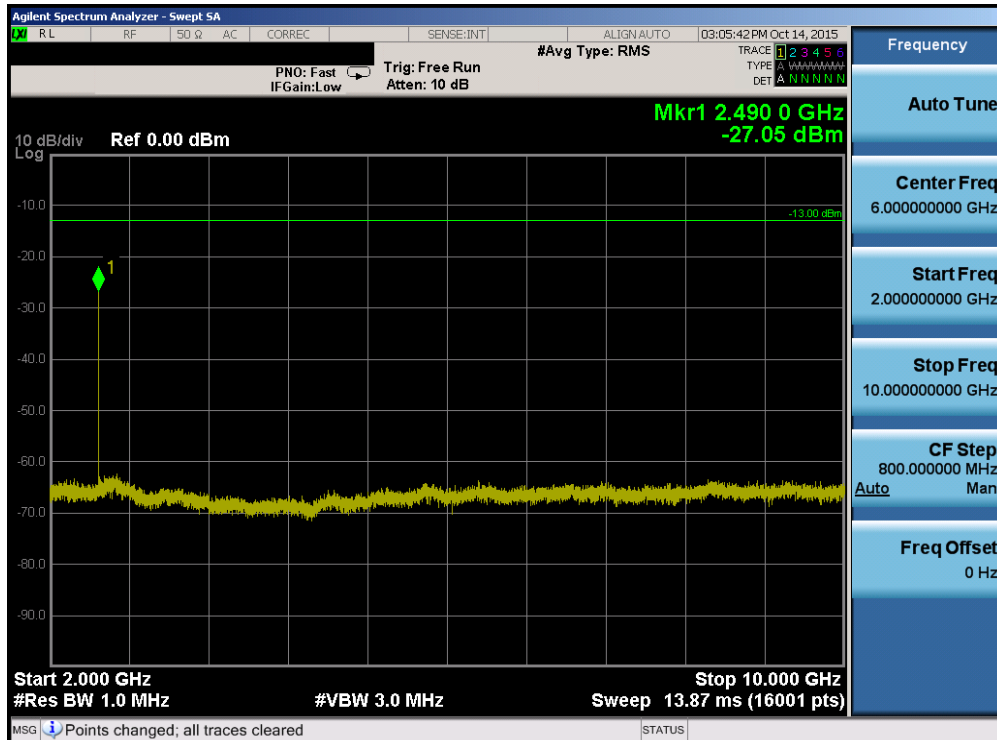

Plot 7-36. Conducted Spurious Plot (Band 26 – 15.0MHz QPSK – RB Size 1, RB Offset 0 – Mid Channel)

FCC ID: ZNFLS675		FCC Pt. 22, 24, & 27 LTE MEASUREMENT REPORT (CERTIFICATION)		Reviewed by: Quality Manager
Test Report S/N: 0Y1511161951.ZNF	Test Dates: 10/12-10/16/2015, 11/17 - 11/27/2015	EUT Type: Portable Handset		Page 33 of 110

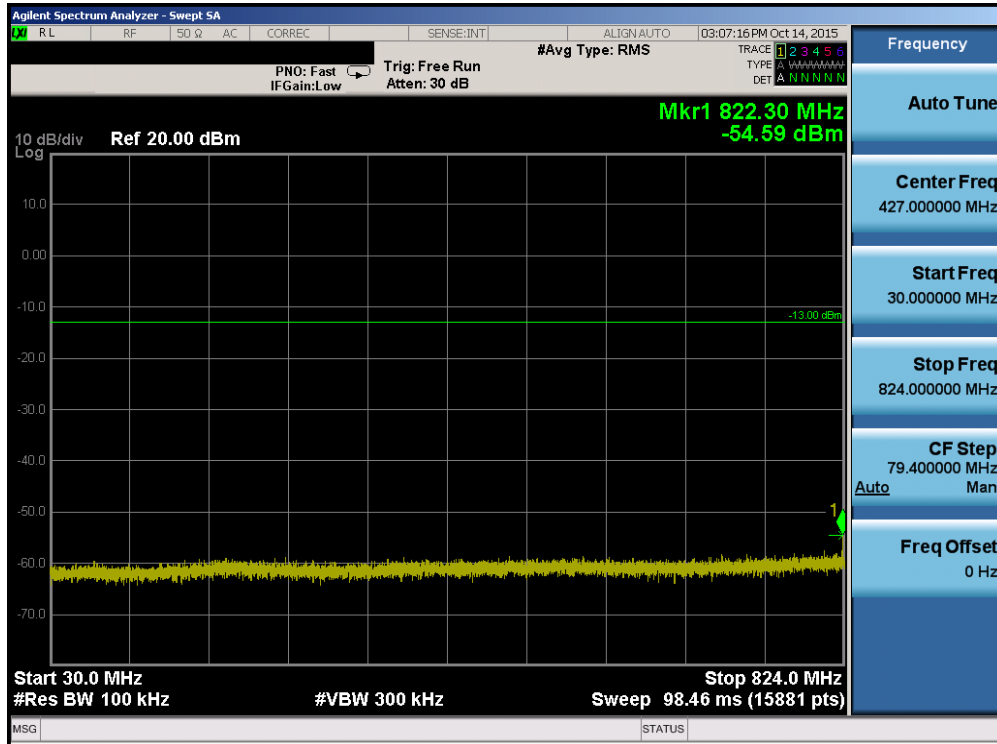

Plot 7-37. Conducted Spurious Plot (Band 26 – 15.0MHz QPSK – RB Size 1, RB Offset 0 – High Channel)

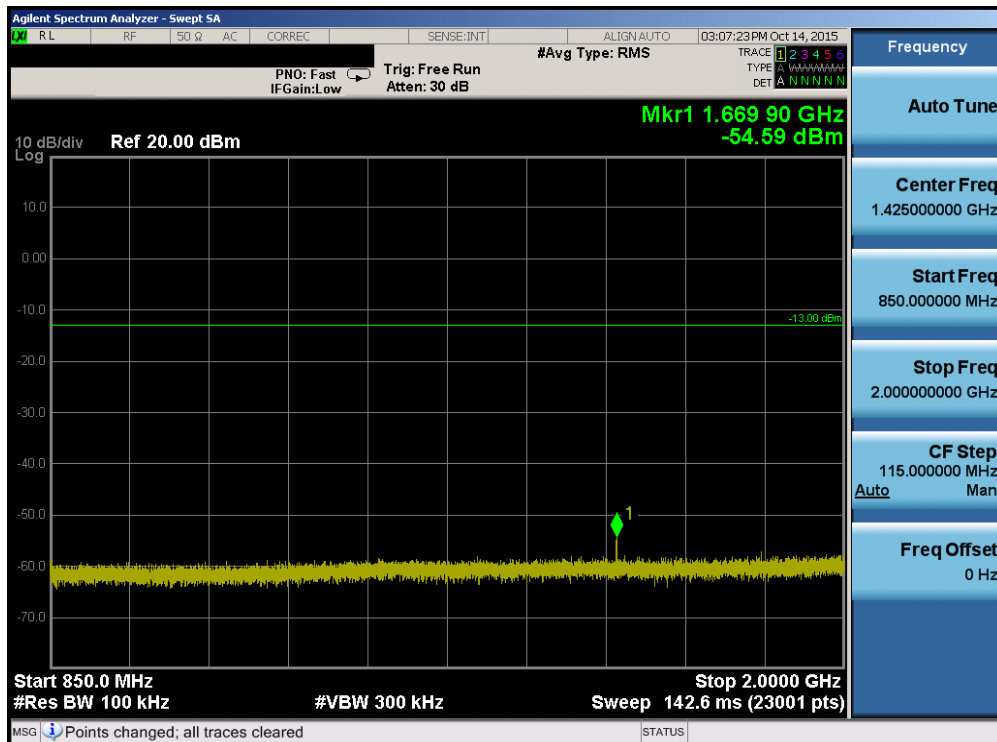

Plot 7-38. Conducted Spurious Plot (Band 26 – 15.0MHz QPSK – RB Size 1, RB Offset 0 – High Channel)

FCC ID: ZNFLS675		FCC Pt. 22, 24, & 27 LTE MEASUREMENT REPORT (CERTIFICATION)		Reviewed by: Quality Manager
Test Report S/N: 0Y1511161951.ZNF	Test Dates: 10/12-10/16/2015, 11/17 - 11/27/2015	EUT Type: Portable Handset		Page 34 of 110

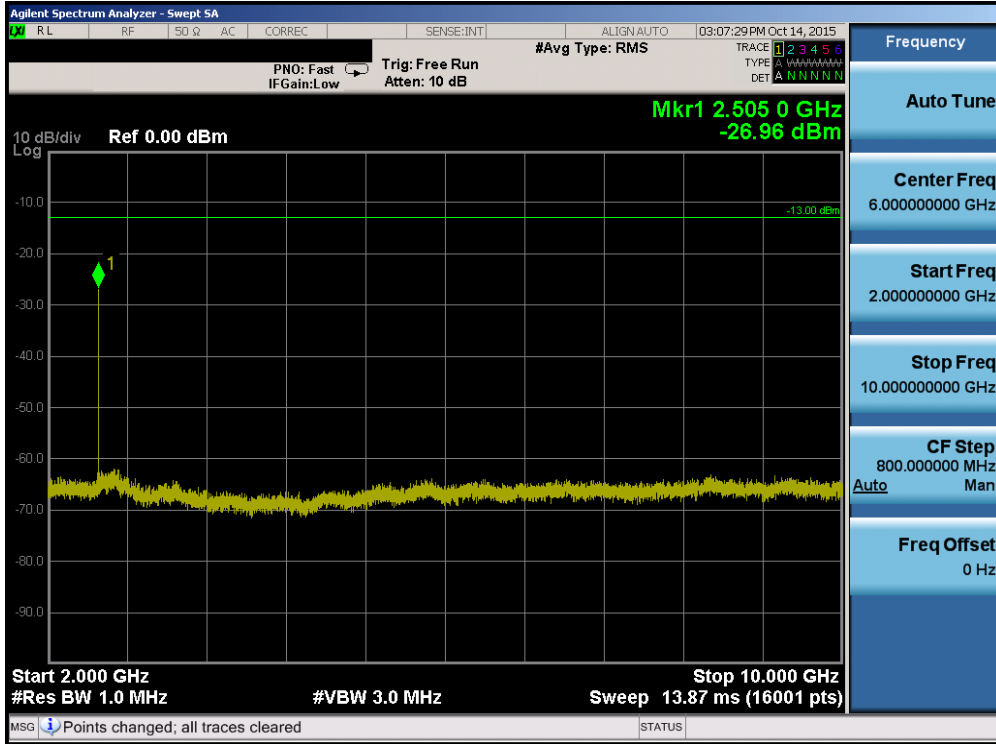

Plot 7-39. Conducted Spurious Plot (Band 26 – 15.0MHz QPSK – RB Size 1, RB Offset 0 – High Channel)

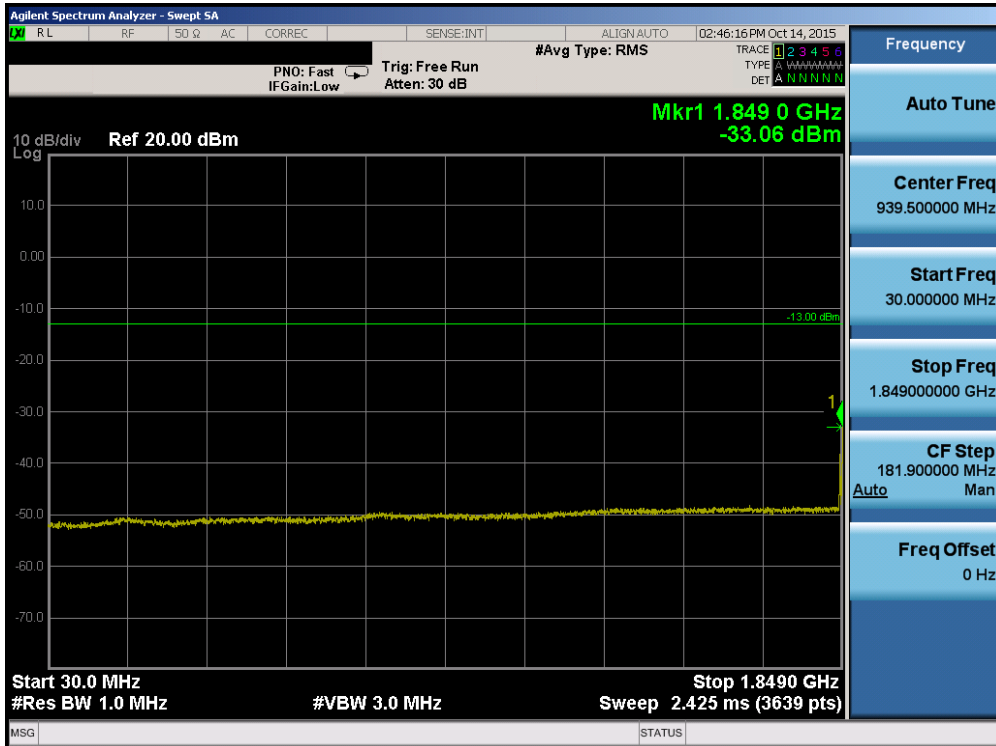

Plot 7-40. Conducted Spurious Plot (Band 25 – 20.0MHz QPSK – RB Size 1, RB Offset 0– Low Channel)

FCC ID: ZNFLS675		FCC Pt. 22, 24, & 27 LTE MEASUREMENT REPORT (CERTIFICATION)		Reviewed by: Quality Manager
Test Report S/N: 0Y1511161951.ZNF	Test Dates: 10/12-10/16/2015, 11/17 - 11/27/2015	EUT Type: Portable Handset		Page 35 of 110

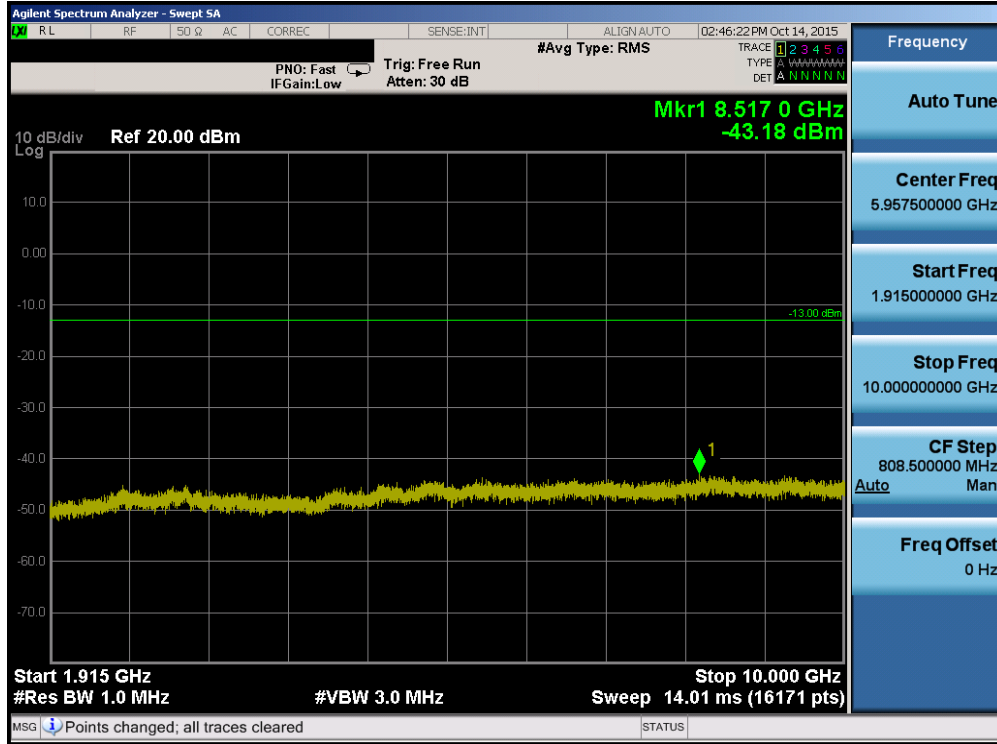

Plot 7-41. Conducted Spurious Plot (Band 25 – 20.0MHz QPSK – RB Size 1, RB Offset 0 – Low Channel)

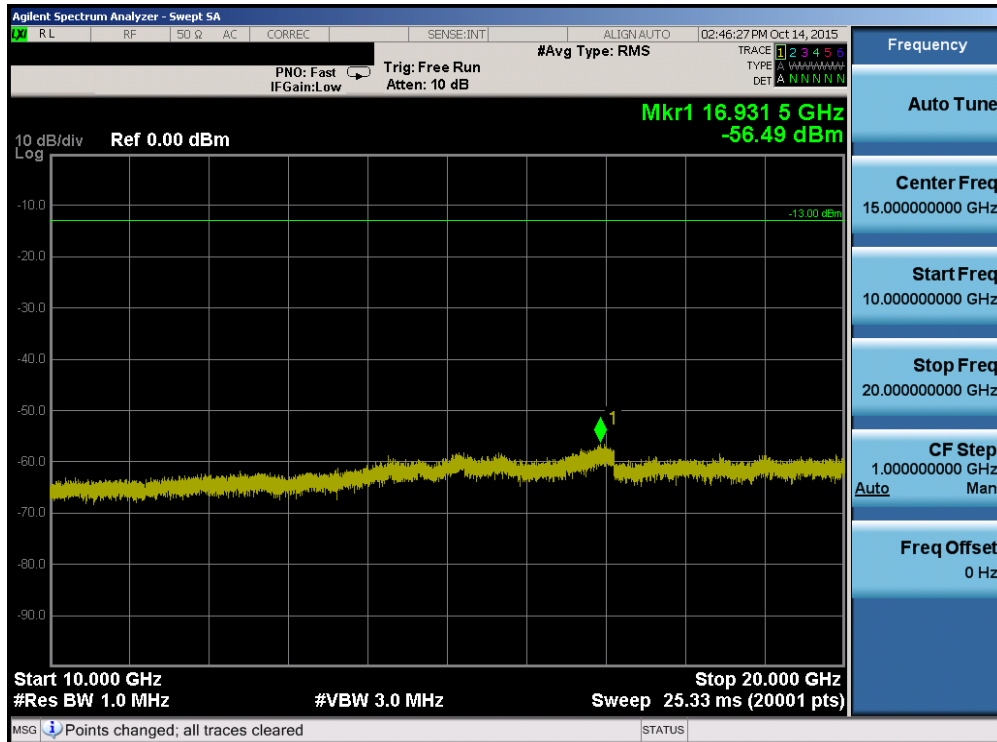

Plot 7-42. Conducted Spurious Plot (Band 25 – 20.0MHz QPSK – RB Size 1, RB Offset 0 – Low Channel)

FCC ID: ZNFLS675		FCC Pt. 22, 24, & 27 LTE MEASUREMENT REPORT (CERTIFICATION)		Reviewed by: Quality Manager
Test Report S/N: 0Y1511161951.ZNF	Test Dates: 10/12-10/16/2015, 11/17 - 11/27/2015	EUT Type: Portable Handset		Page 36 of 110

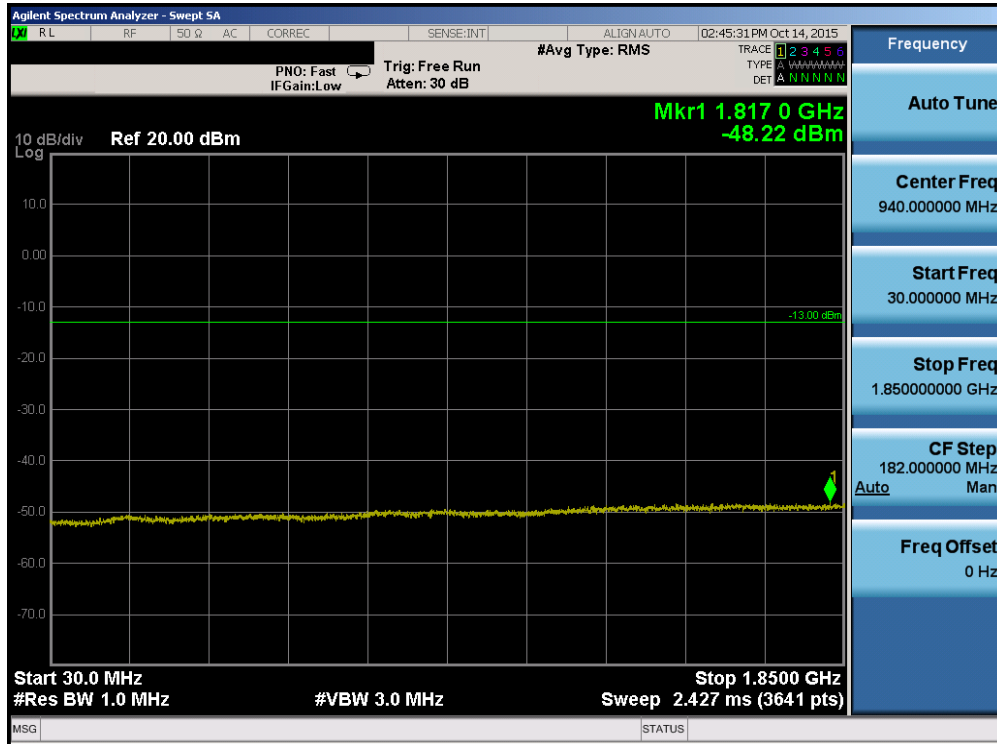

Plot 7-43. Conducted Spurious Plot (Band 25 – 20.0MHz QPSK – RB Size 1, RB Offset 0 – Mid Channel)

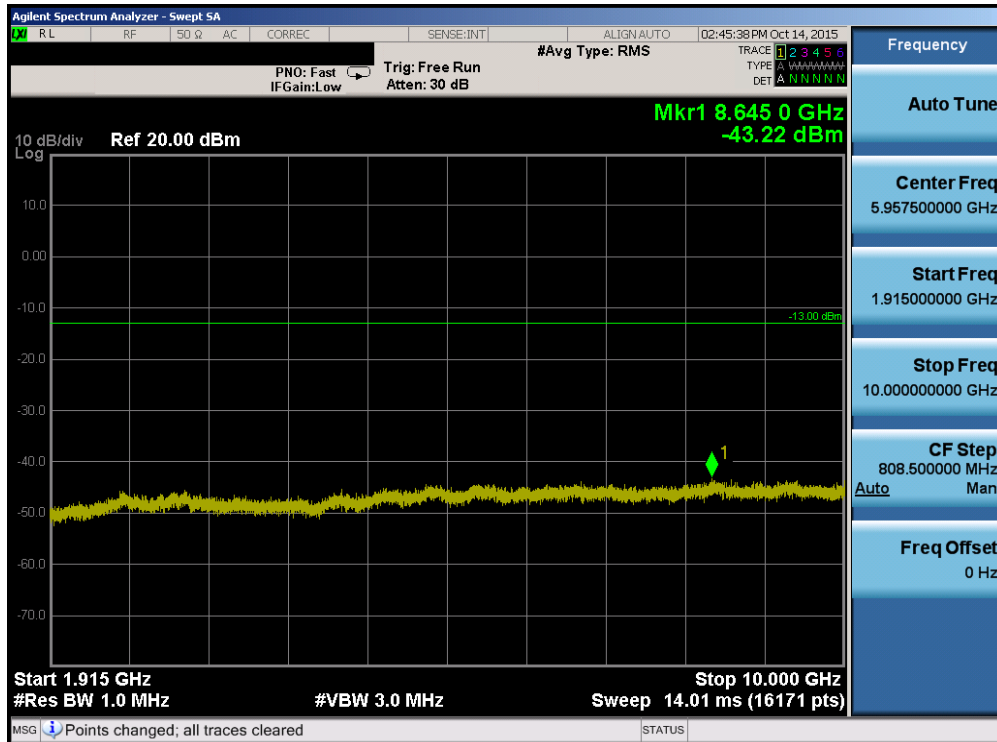

Plot 7-44. Conducted Spurious Plot (Band 25 – 20.0MHz QPSK – RB Size 1, RB Offset 0 – Mid Channel)

FCC ID: ZNFLS675		FCC Pt. 22, 24, & 27 LTE MEASUREMENT REPORT (CERTIFICATION)		Reviewed by: Quality Manager
Test Report S/N: 0Y1511161951.ZNF	Test Dates: 10/12-10/16/2015, 11/17 - 11/27/2015	EUT Type: Portable Handset		Page 37 of 110

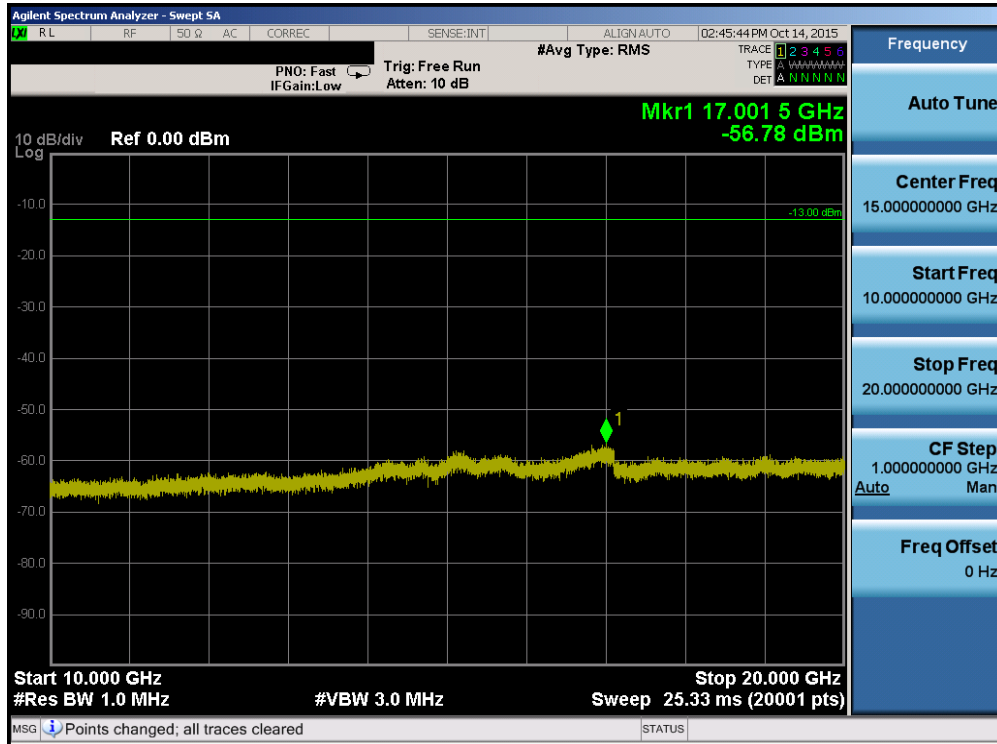

Plot 7-45. Conducted Spurious Plot (Band 25 – 20.0MHz QPSK – RB Size 1, RB Offset 0 – Mid Channel)

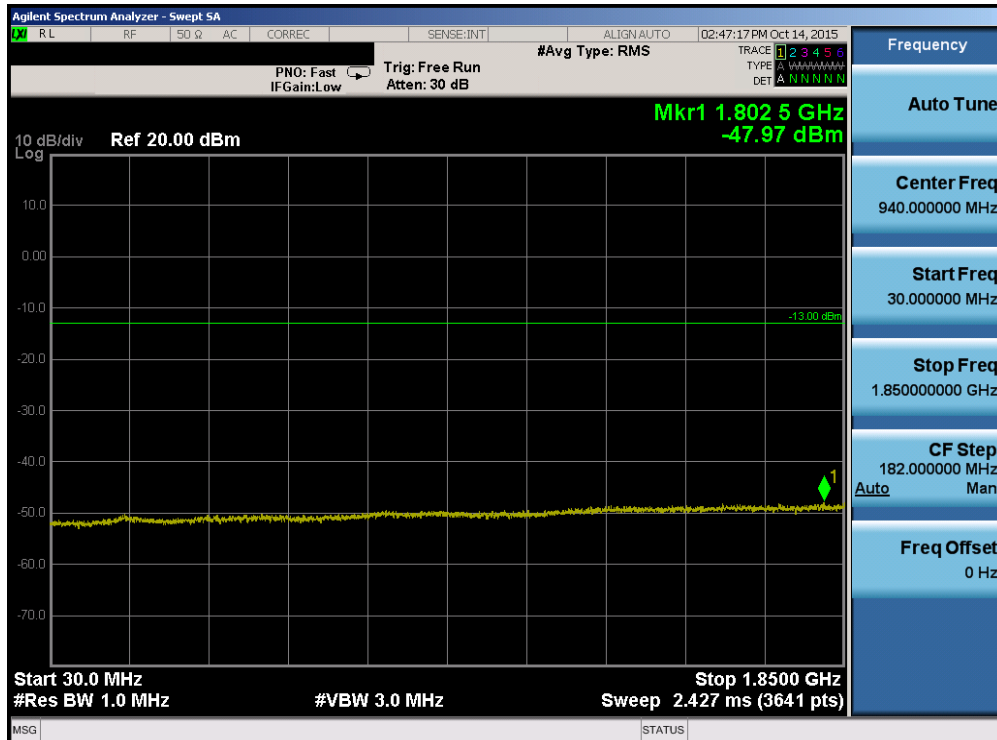

Plot 7-46. Conducted Spurious Plot (Band 25 – 20.0MHz QPSK – RB Size 1, RB Offset 0 – High Channel)

FCC ID: ZNFLS675		FCC Pt. 22, 24, & 27 LTE MEASUREMENT REPORT (CERTIFICATION)		Reviewed by: Quality Manager
Test Report S/N: 0Y1511161951.ZNF	Test Dates: 10/12-10/16/2015, 11/17 - 11/27/2015	EUT Type: Portable Handset		Page 38 of 110

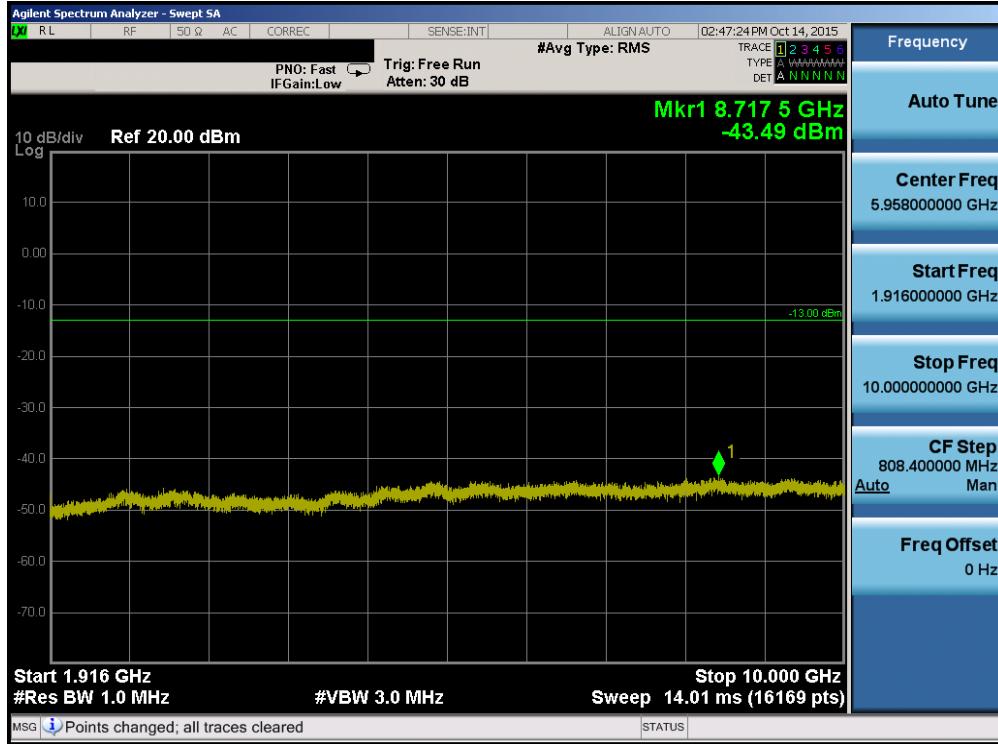

Plot 7-47. Conducted Spurious Plot (Band 25 – 20.0MHz QPSK – RB Size 1, RB Offset 0 – High Channel)

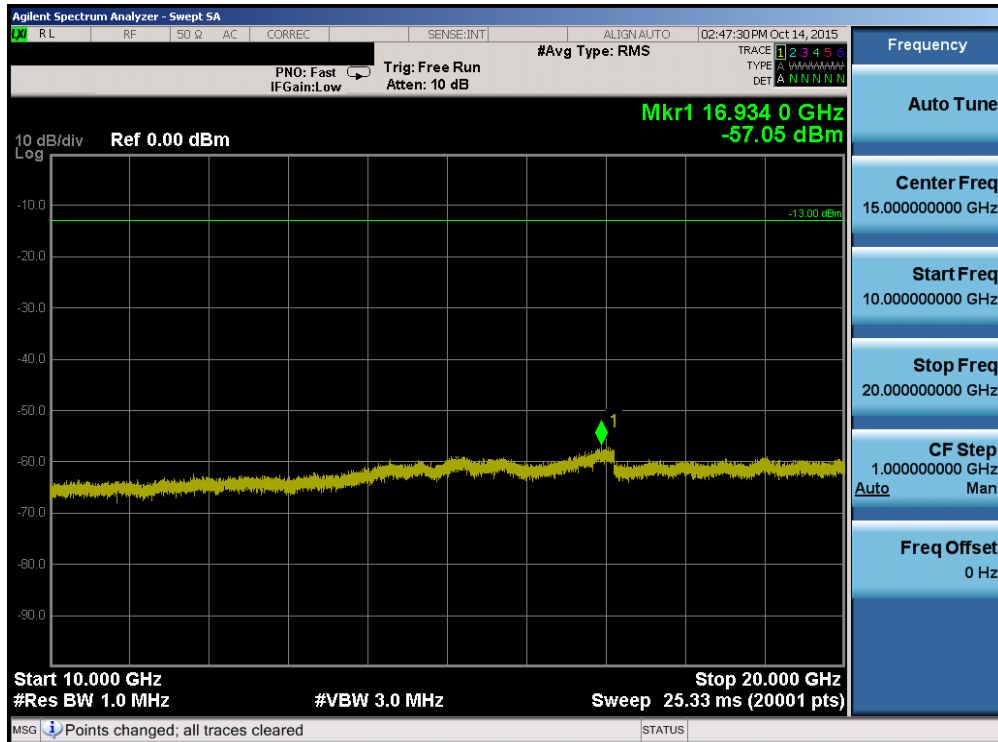

Plot 7-48. Conducted Spurious Plot (Band 25 – 20.0MHz QPSK – RB Size 1, RB Offset 0 – High Channel)

FCC ID: ZNFLS675		FCC Pt. 22, 24, & 27 LTE MEASUREMENT REPORT (CERTIFICATION)		Reviewed by: Quality Manager
Test Report S/N: 0Y1511161951.ZNF	Test Dates: 10/12-10/16/2015, 11/17 - 11/27/2015	EUT Type: Portable Handset		Page 39 of 110

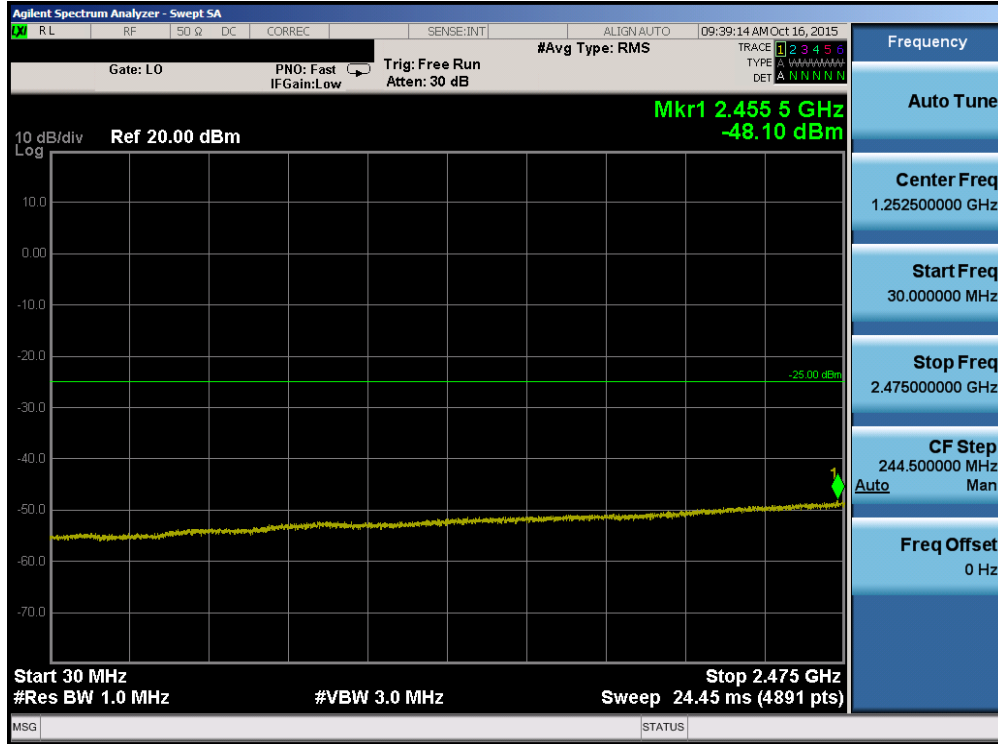

Plot 7-49. Conducted Spurious Plot (Band 41 – 5.0MHz QPSK – RB Size 1, RB Offset 0 – Low Channel)

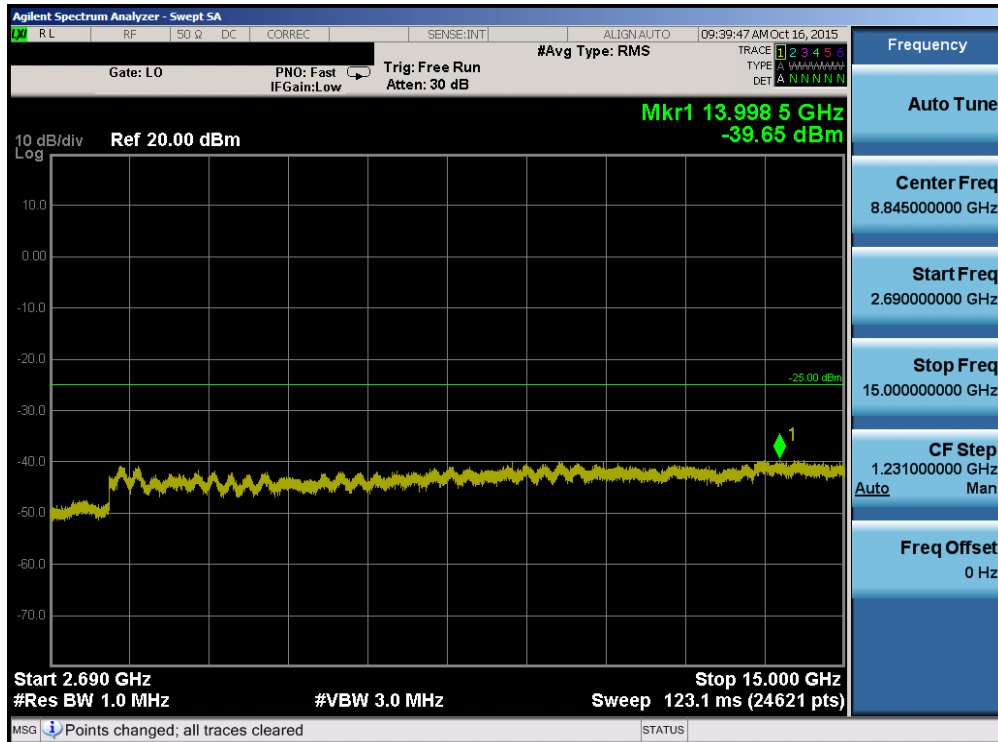

Plot 7-50. Conducted Spurious Plot (Band 41 – 5.0MHz QPSK – RB Size 1, RB Offset 0 – Low Channel)

FCC ID: ZNFLS675		FCC Pt. 22, 24, & 27 LTE MEASUREMENT REPORT (CERTIFICATION)		Reviewed by: Quality Manager
Test Report S/N: 0Y1511161951.ZNF	Test Dates: 10/12-10/16/2015, 11/17 - 11/27/2015	EUT Type: Portable Handset		Page 40 of 110



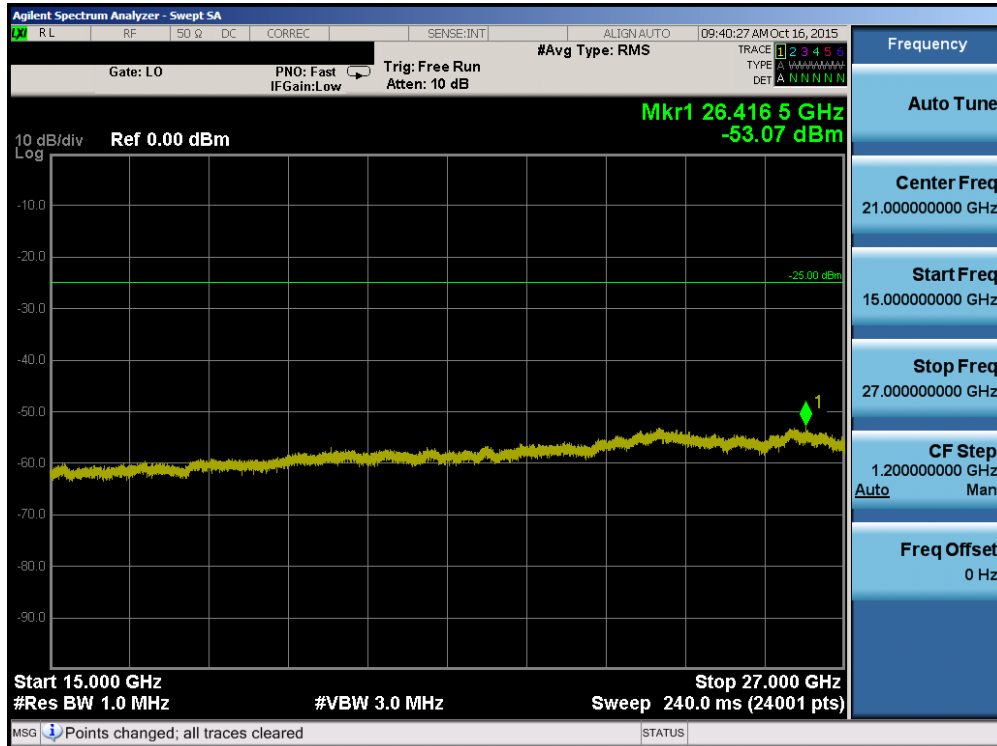

Plot 7-51. Conducted Spurious Plot (Band 41 – 5.0MHz QPSK – RB Size 1, RB Offset 0 – Low Channel)

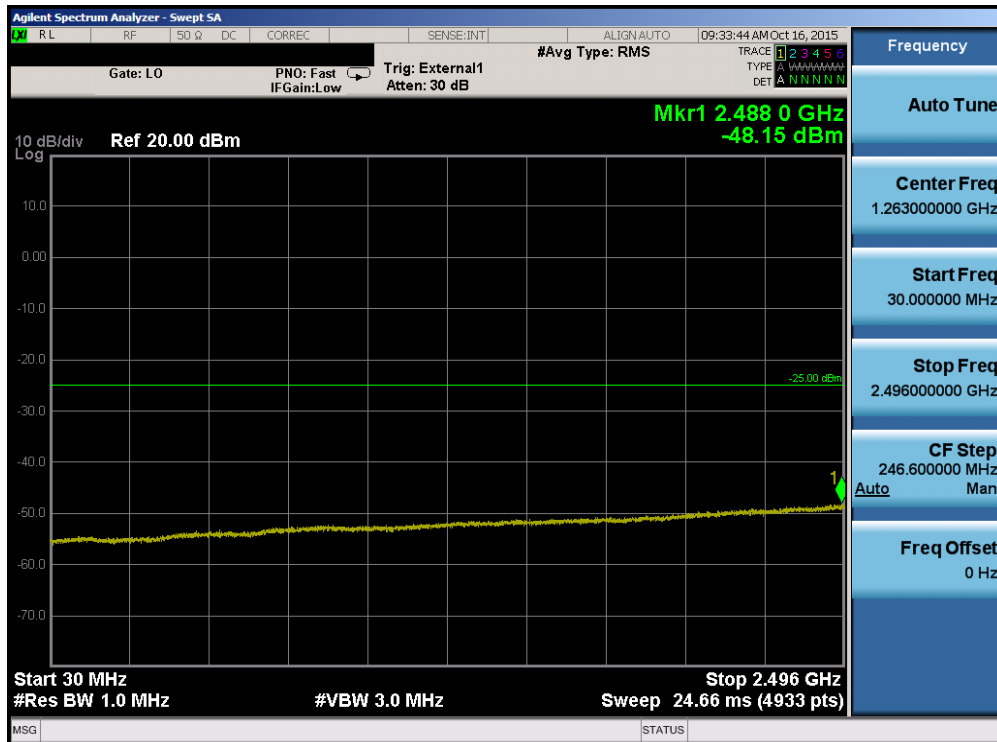

Plot 7-52. Conducted Spurious Plot (Band 41 – 5.0MHz QPSK – RB Size 1, RB Offset 0 – Mid Channel)

FCC ID: ZNFLS675		FCC Pt. 22, 24, & 27 LTE MEASUREMENT REPORT (CERTIFICATION)		Reviewed by: Quality Manager
Test Report S/N: 0Y1511161951.ZNF	Test Dates: 10/12-10/16/2015, 11/17 - 11/27/2015	EUT Type: Portable Handset		Page 41 of 110

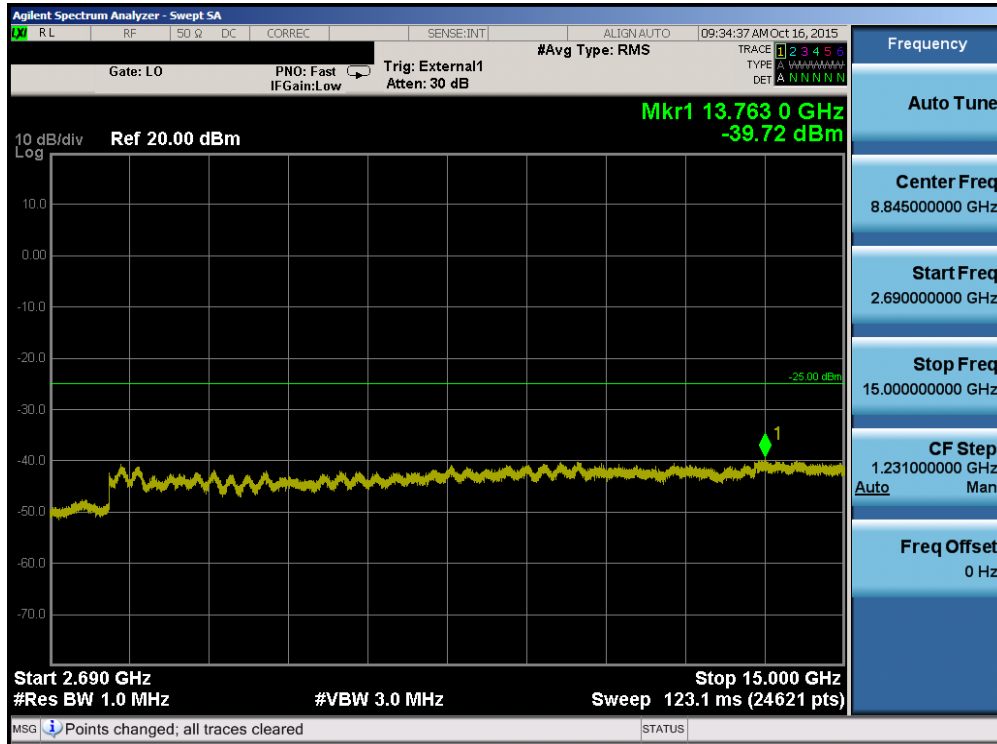

Plot 7-53. Conducted Spurious Plot (Band 41 – 5.0MHz QPSK – RB Size 1, RB Offset 0 – Mid Channel)

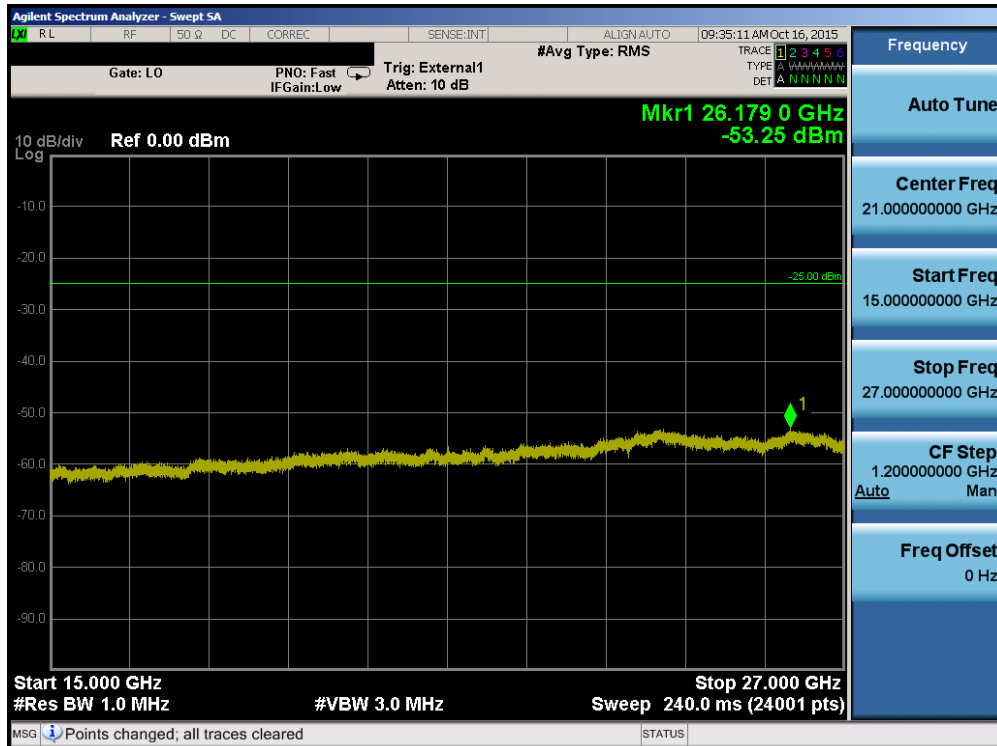

Plot 7-54. Conducted Spurious Plot (Band 41 – 5.0MHz QPSK – RB Size 1, RB Offset 0 – Mid Channel)

FCC ID: ZNFLS675		FCC Pt. 22, 24, & 27 LTE MEASUREMENT REPORT (CERTIFICATION)		Reviewed by: Quality Manager
Test Report S/N: 0Y1511161951.ZNF	Test Dates: 10/12-10/16/2015, 11/17 - 11/27/2015	EUT Type: Portable Handset		Page 42 of 110

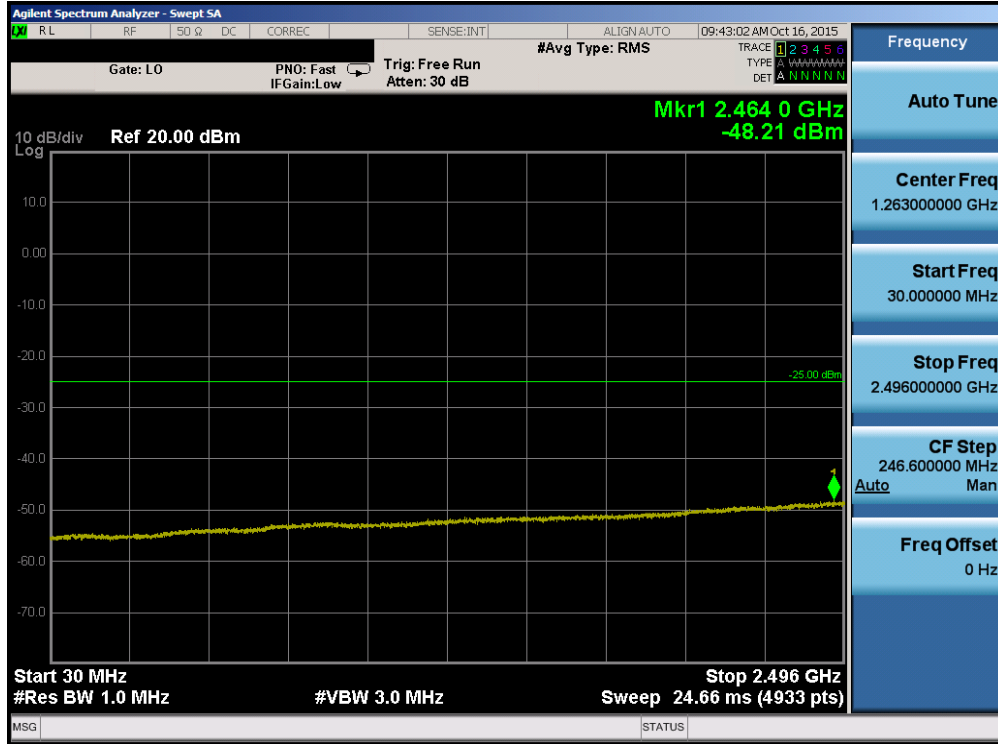

Plot 7-55. Conducted Spurious Plot (Band 41 – 5.0MHz QPSK – RB Size 1, RB Offset 0 – High Channel)

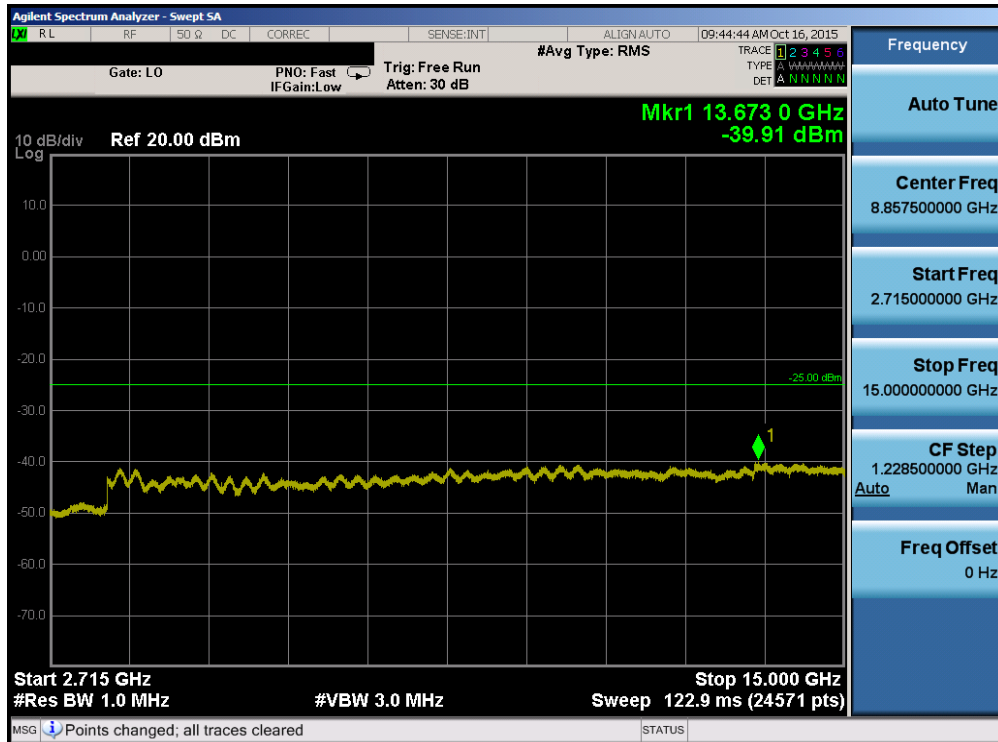

Plot 7-56. Conducted Spurious Plot (Band 41 – 5.0MHz QPSK – RB Size 1, RB Offset 0 – High Channel)

FCC ID: ZNFLS675		FCC Pt. 22, 24, & 27 LTE MEASUREMENT REPORT (CERTIFICATION)		Reviewed by: Quality Manager
Test Report S/N: 0Y1511161951.ZNF	Test Dates: 10/12-10/16/2015, 11/17 - 11/27/2015	EUT Type: Portable Handset		Page 43 of 110



Plot 7-57. Conducted Spurious Plot (Band 41 – 5.0MHz QPSK – RB Size 1, RB Offset 0 – High Channel)

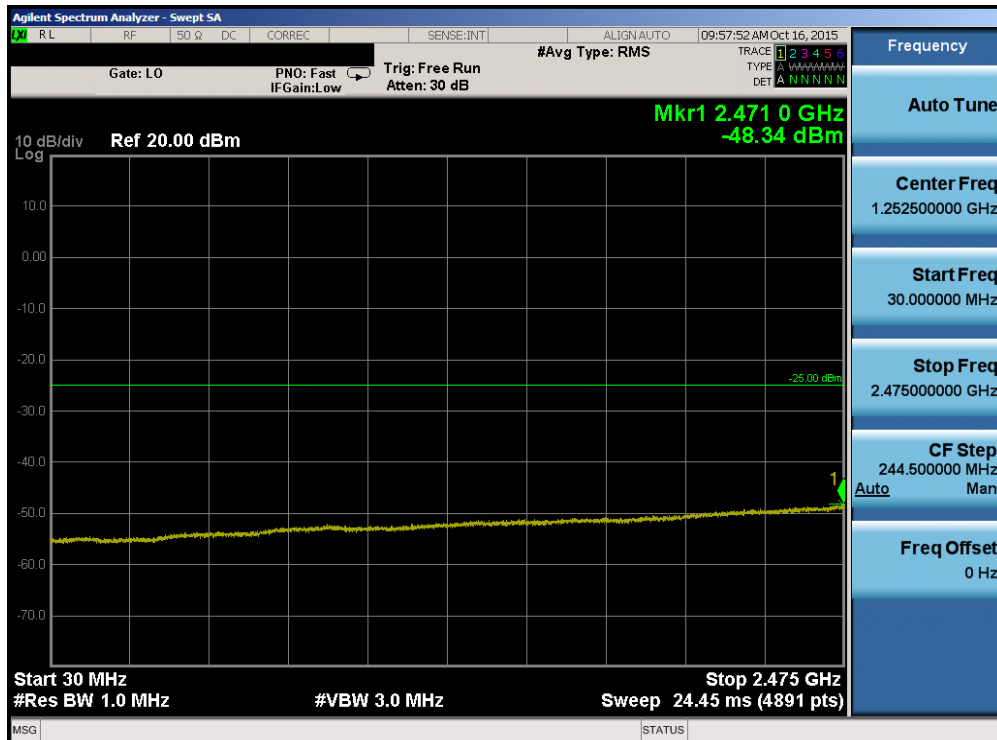

Plot 7-58. Conducted Spurious Plot (Band 41 – 10.0MHz QPSK – RB Size 1, RB Offset 0– Low Channel)

FCC ID: ZNFLS675		FCC Pt. 22, 24, & 27 LTE MEASUREMENT REPORT (CERTIFICATION)		Reviewed by: Quality Manager
Test Report S/N: 0Y1511161951.ZNF	Test Dates: 10/12-10/16/2015, 11/17 - 11/27/2015	EUT Type: Portable Handset		Page 44 of 110

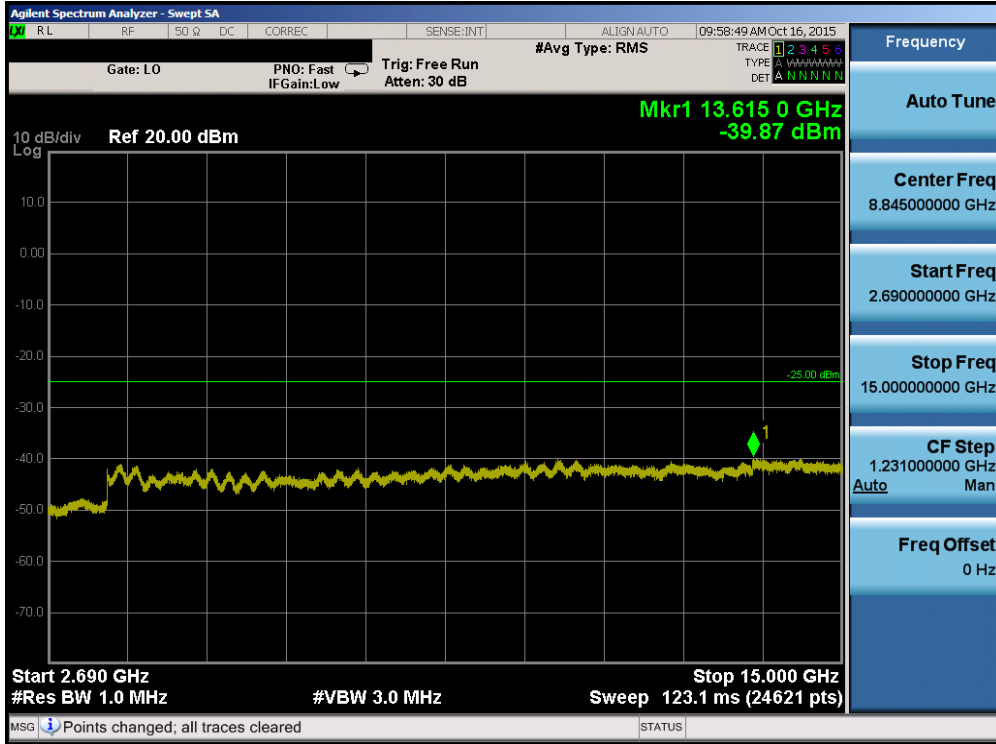

Plot 7-59. Conducted Spurious Plot (Band 41 – 10.0MHz QPSK – RB Size 1, RB Offset 0 – Low Channel)



Plot 7-60. Conducted Spurious Plot (Band 41 – 10.0MHz QPSK – RB Size 1, RB Offset 0 – Low Channel)

FCC ID: ZNFLS675		FCC Pt. 22, 24, & 27 LTE MEASUREMENT REPORT (CERTIFICATION)		Reviewed by: Quality Manager
Test Report S/N: 0Y1511161951.ZNF	Test Dates: 10/12-10/16/2015, 11/17 - 11/27/2015	EUT Type: Portable Handset		Page 45 of 110

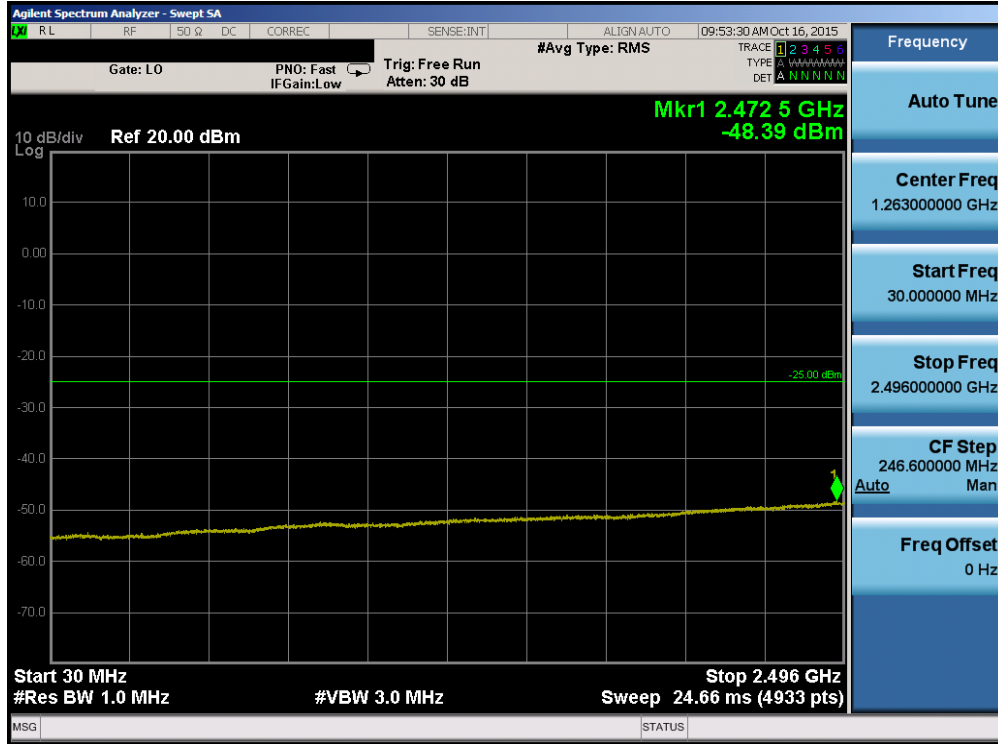

Plot 7-61. Conducted Spurious Plot (Band 41 – 10.0MHz QPSK – RB Size 1, RB Offset 0 – Mid Channel)

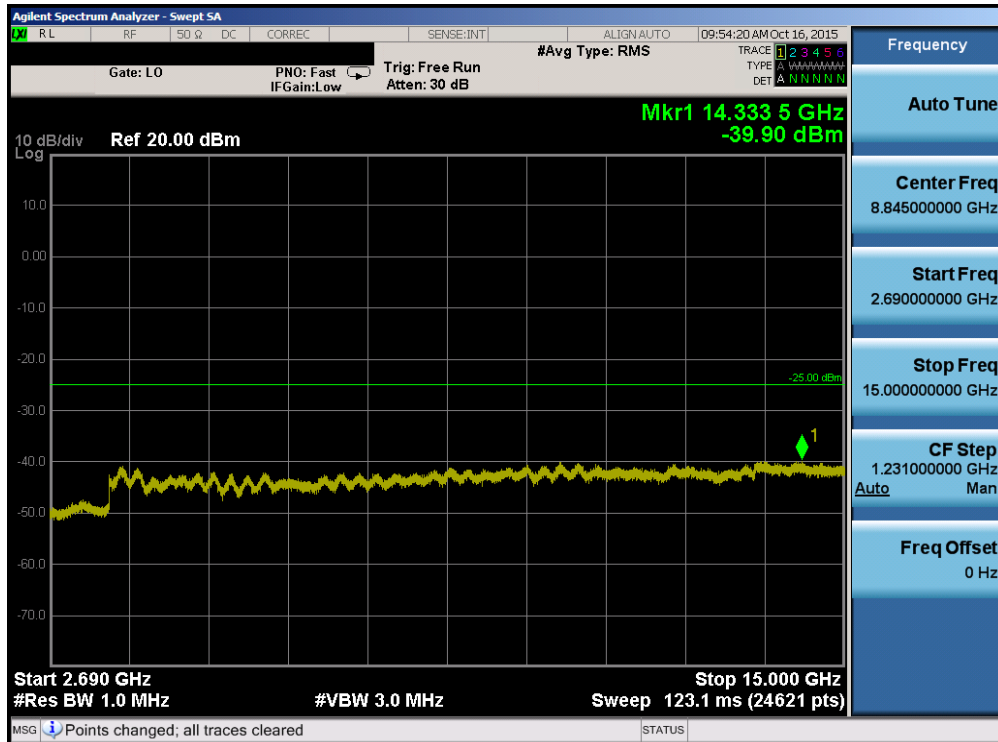

Plot 7-62. Conducted Spurious Plot (Band 41 – 10.0MHz QPSK – RB Size 1, RB Offset 0 – Mid Channel)

FCC ID: ZNFLS675		FCC Pt. 22, 24, & 27 LTE MEASUREMENT REPORT (CERTIFICATION)		Reviewed by: Quality Manager
Test Report S/N: 0Y1511161951.ZNF	Test Dates: 10/12-10/16/2015, 11/17 - 11/27/2015	EUT Type: Portable Handset		Page 46 of 110

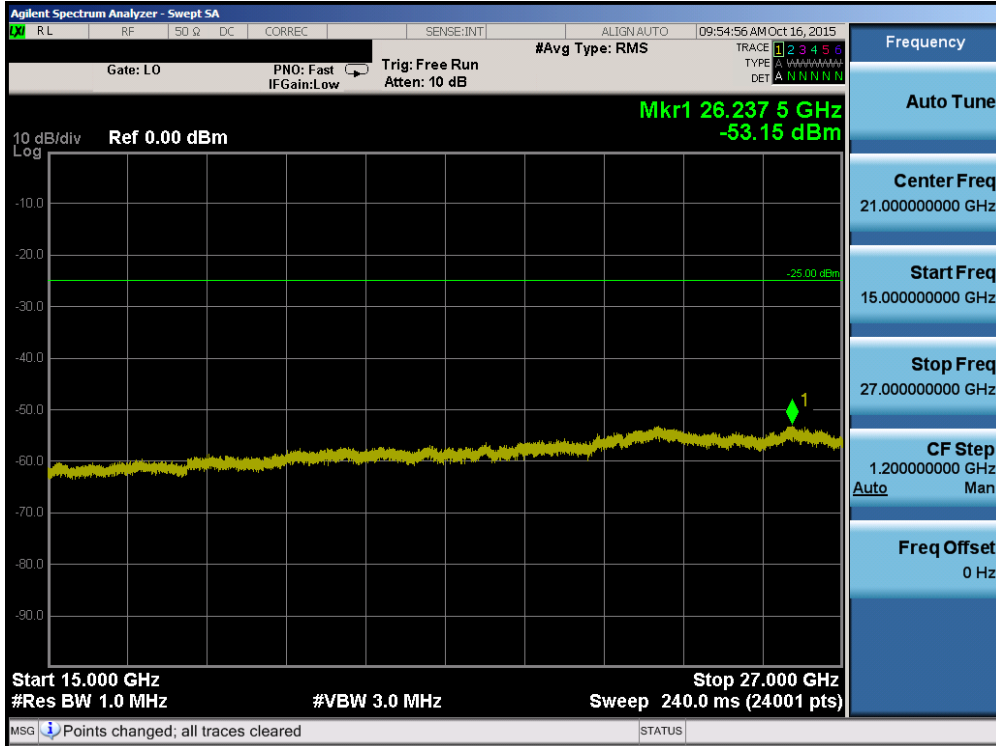

Plot 7-63. Conducted Spurious Plot (Band 41 – 10.0MHz QPSK – RB Size 1, RB Offset 0 – Mid Channel)

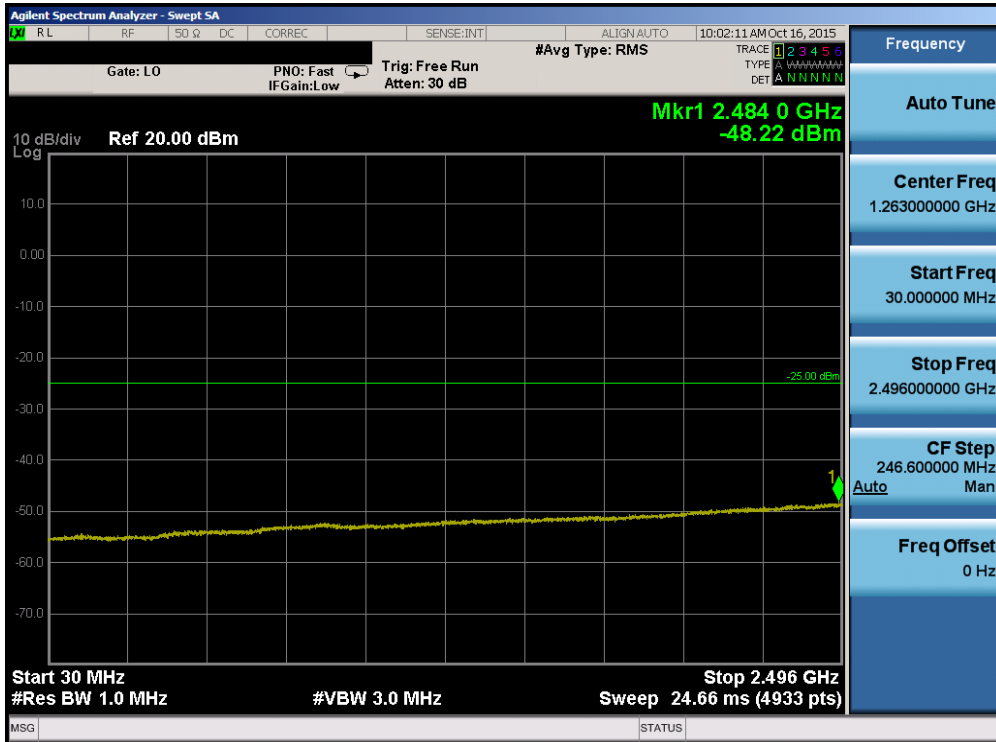

Plot 7-64. Conducted Spurious Plot (Band 41 – 10.0MHz QPSK – RB Size 1, RB Offset 0 – High Channel)

FCC ID: ZNFLS675		FCC Pt. 22, 24, & 27 LTE MEASUREMENT REPORT (CERTIFICATION)		Reviewed by: Quality Manager
Test Report S/N: 0Y1511161951.ZNF	Test Dates: 10/12-10/16/2015, 11/17 - 11/27/2015	EUT Type: Portable Handset		Page 47 of 110

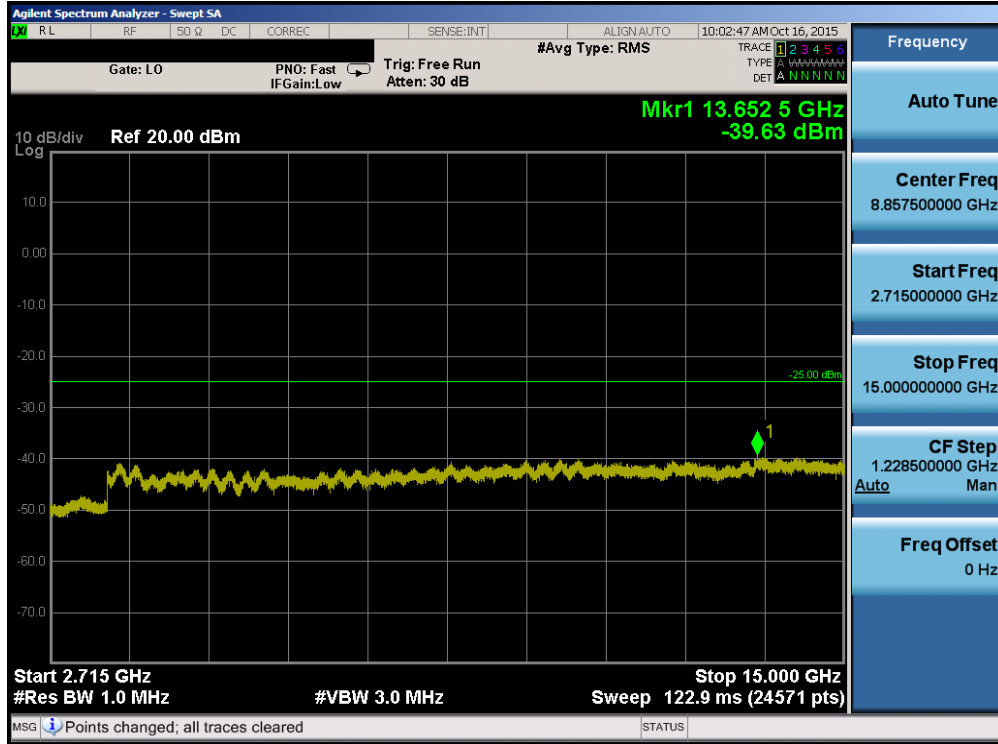

Plot 7-65. Conducted Spurious Plot (Band 41 – 10.0MHz QPSK – RB Size 1, RB Offset 0 – High Channel)

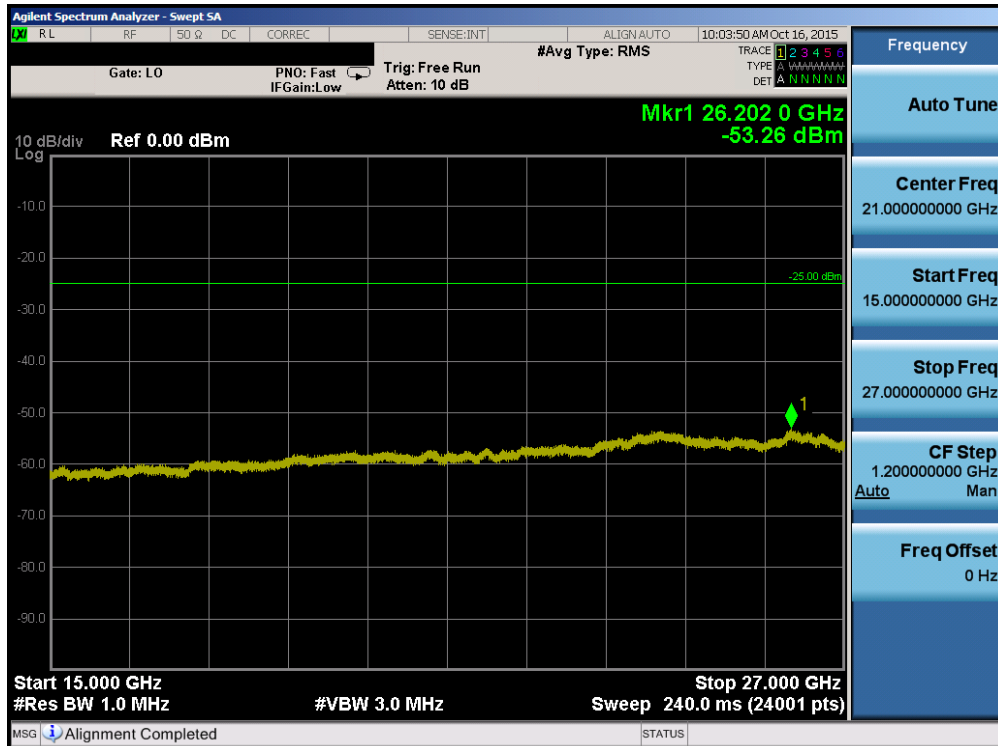

Plot 7-66. Conducted Spurious Plot (Band 41 – 10.0MHz QPSK – RB Size 1, RB Offset 0 – High Channel)

FCC ID: ZNFLS675		FCC Pt. 22, 24, & 27 LTE MEASUREMENT REPORT (CERTIFICATION)		Reviewed by: Quality Manager
Test Report S/N: 0Y1511161951.ZNF	Test Dates: 10/12-10/16/2015, 11/17 - 11/27/2015	EUT Type: Portable Handset		Page 48 of 110



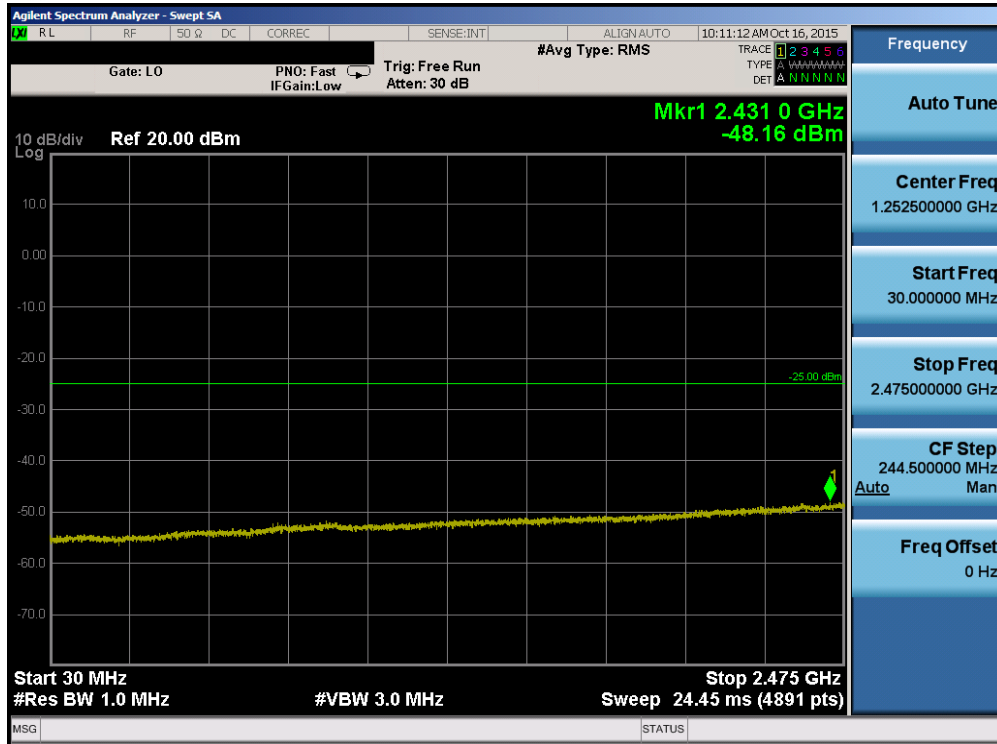

Plot 7-67. Conducted Spurious Plot (Band 41 – 15.0MHz QPSK – RB Size 1, RB Offset 0 – Low Channel)

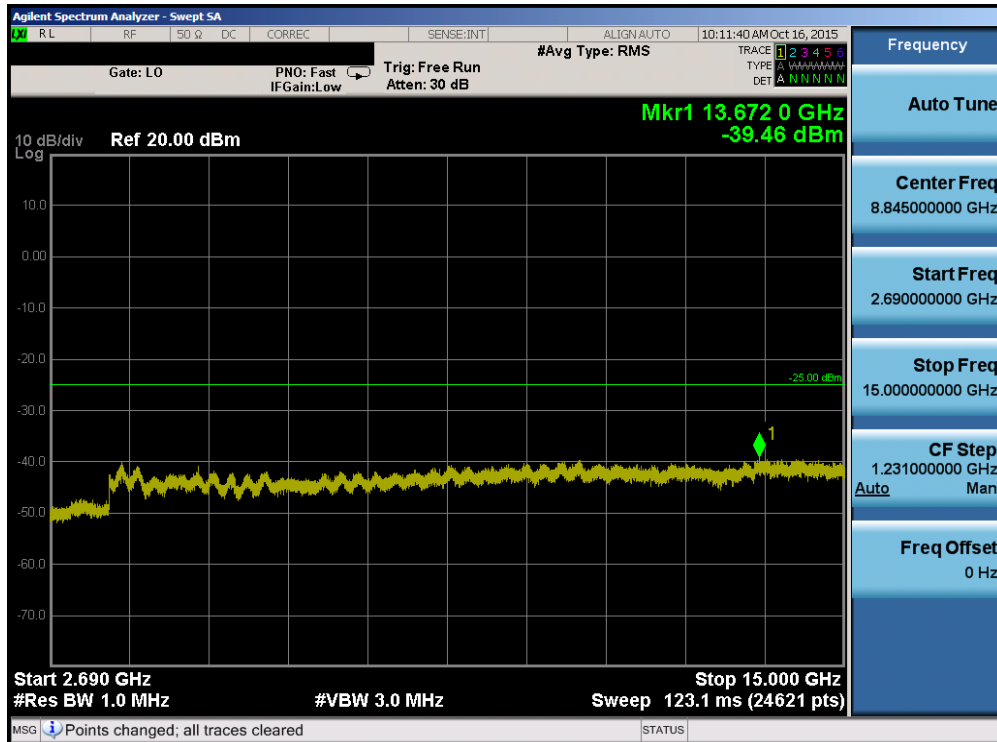

Plot 7-68. Conducted Spurious Plot (Band 41 – 15.0MHz QPSK – RB Size 1, RB Offset 0 – Low Channel)

FCC ID: ZNFLS675		FCC Pt. 22, 24, & 27 LTE MEASUREMENT REPORT (CERTIFICATION)		Reviewed by: Quality Manager
Test Report S/N: 0Y1511161951.ZNF	Test Dates: 10/12-10/16/2015, 11/17 - 11/27/2015	EUT Type: Portable Handset		Page 49 of 110

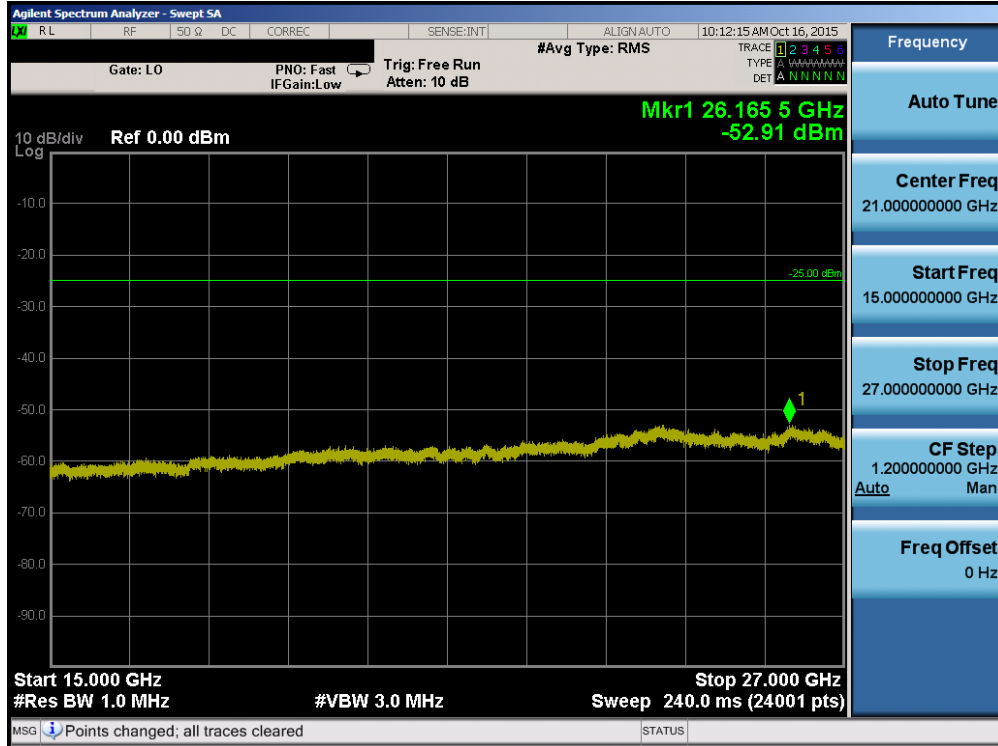

Plot 7-69. Conducted Spurious Plot (Band 41 – 15.0MHz QPSK – RB Size 1, RB Offset 0 – Low Channel)

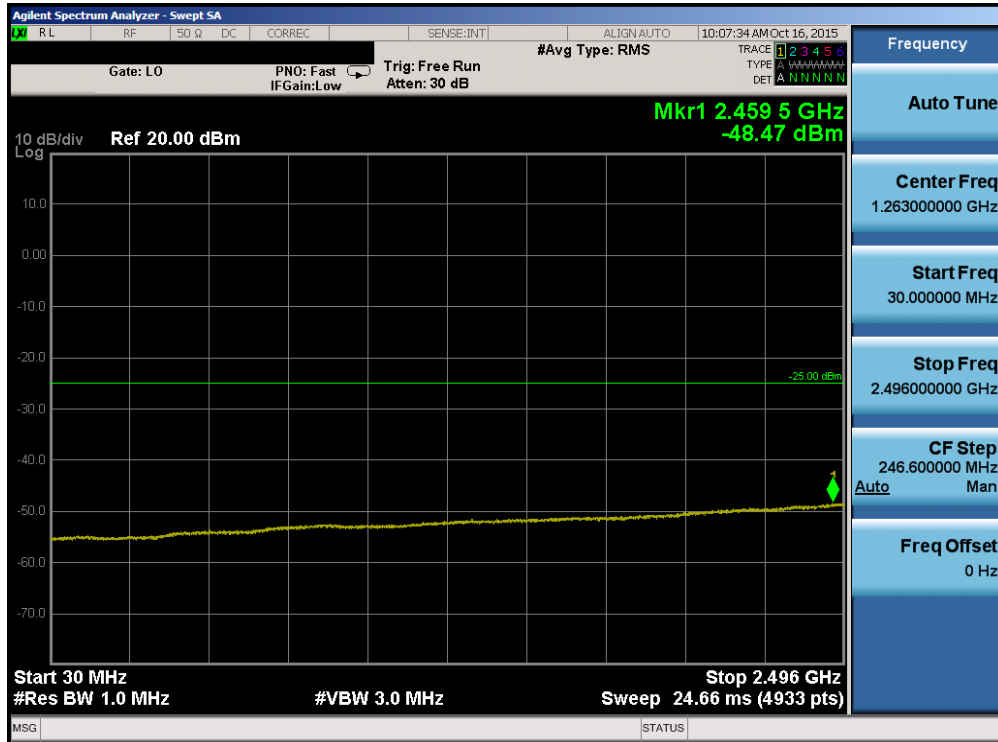

Plot 7-70. Conducted Spurious Plot (Band 41 – 15.0MHz QPSK – RB Size 1, RB Offset 0 – Mid Channel)

FCC ID: ZNFLS675		FCC Pt. 22, 24, & 27 LTE MEASUREMENT REPORT (CERTIFICATION)		Reviewed by: Quality Manager
Test Report S/N: 0Y1511161951.ZNF	Test Dates: 10/12-10/16/2015, 11/17 - 11/27/2015	EUT Type: Portable Handset		Page 50 of 110

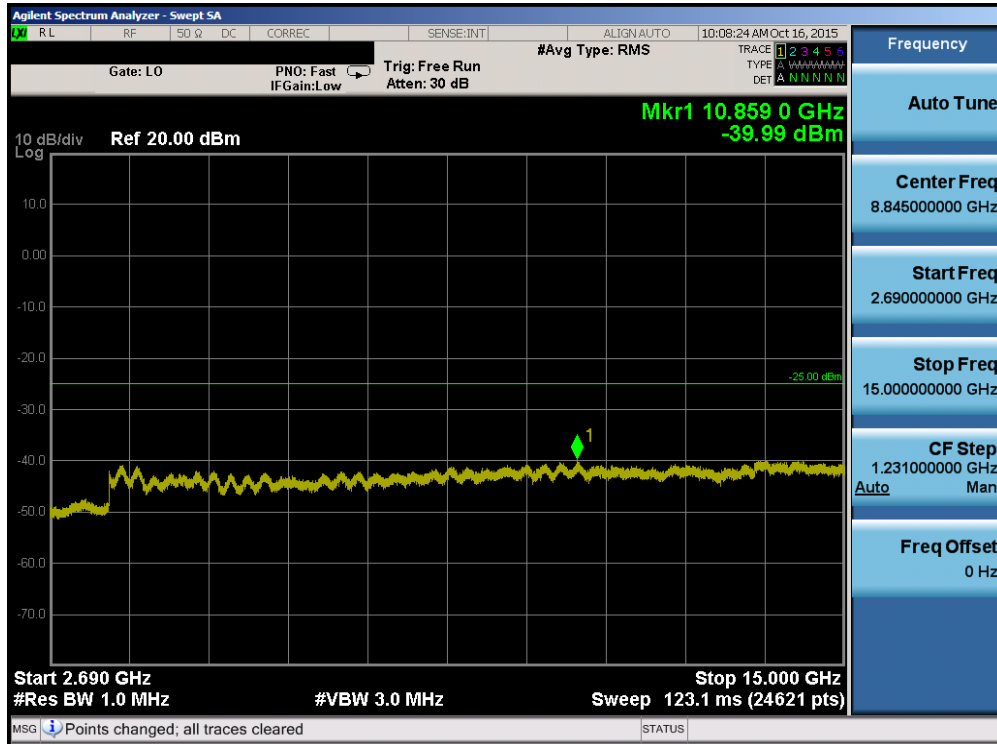

Plot 7-71. Conducted Spurious Plot (Band 41 – 15.0MHz QPSK – RB Size 1, RB Offset 0 – Mid Channel)

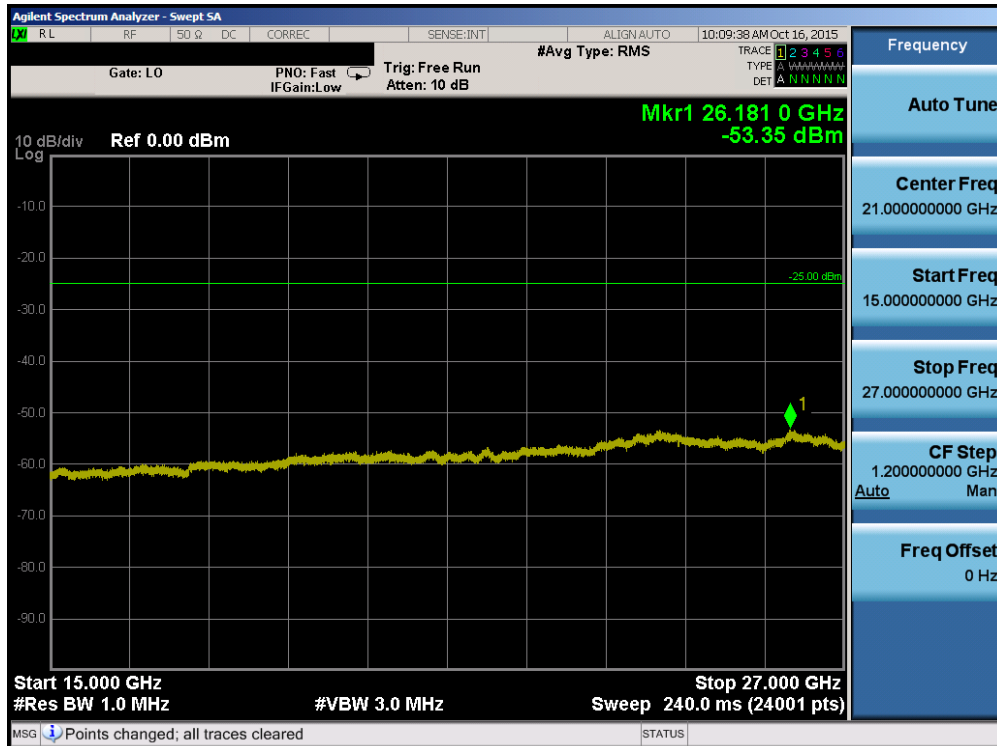

Plot 7-72. Conducted Spurious Plot (Band 41 – 15.0MHz QPSK – RB Size 1, RB Offset 0 – Mid Channel)

FCC ID: ZNFLS675		FCC Pt. 22, 24, & 27 LTE MEASUREMENT REPORT (CERTIFICATION)		Reviewed by: Quality Manager
Test Report S/N: 0Y1511161951.ZNF	Test Dates: 10/12-10/16/2015, 11/17 - 11/27/2015	EUT Type: Portable Handset		Page 51 of 110

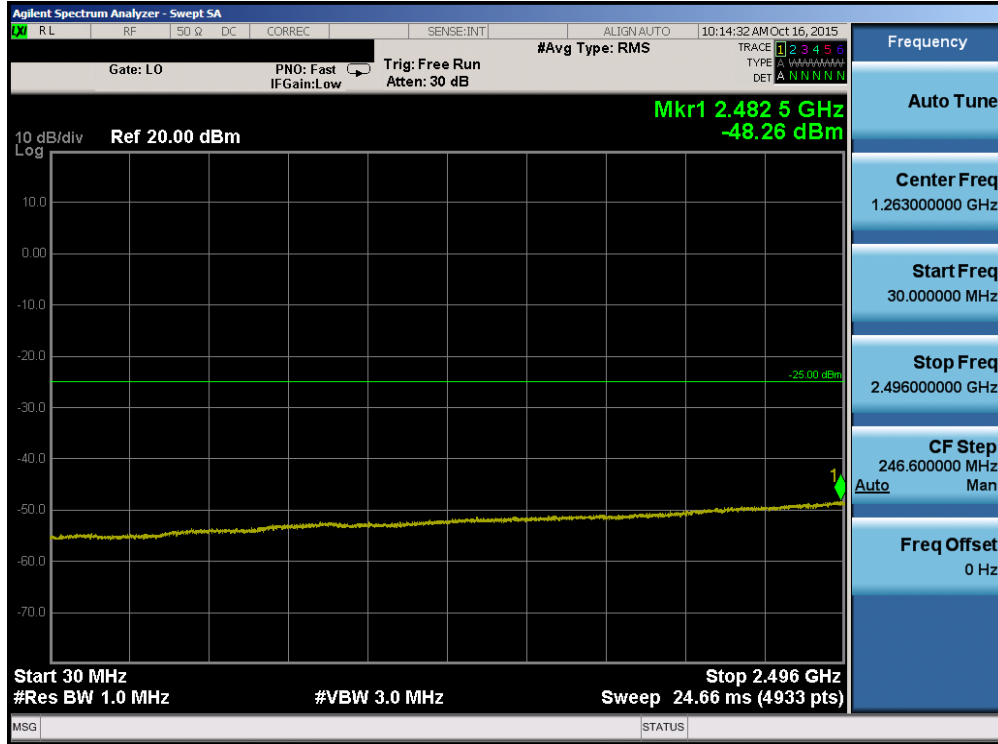

Plot 7-73. Conducted Spurious Plot (Band 41 – 15.0MHz QPSK – RB Size 1, RB Offset 0 – High Channel)

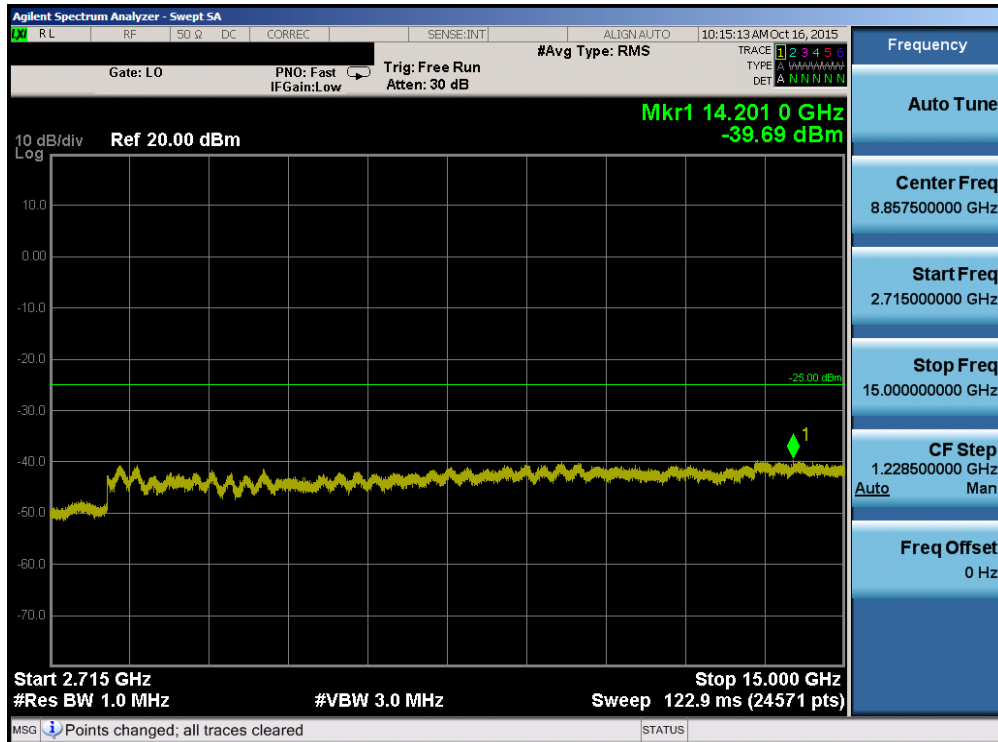

Plot 7-74. Conducted Spurious Plot (Band 41 – 15.0MHz QPSK – RB Size 1, RB Offset 0 – High Channel)

FCC ID: ZNFLS675		FCC Pt. 22, 24, & 27 LTE MEASUREMENT REPORT (CERTIFICATION)		Reviewed by: Quality Manager
Test Report S/N: 0Y1511161951.ZNF	Test Dates: 10/12-10/16/2015, 11/17 - 11/27/2015	EUT Type: Portable Handset		Page 52 of 110

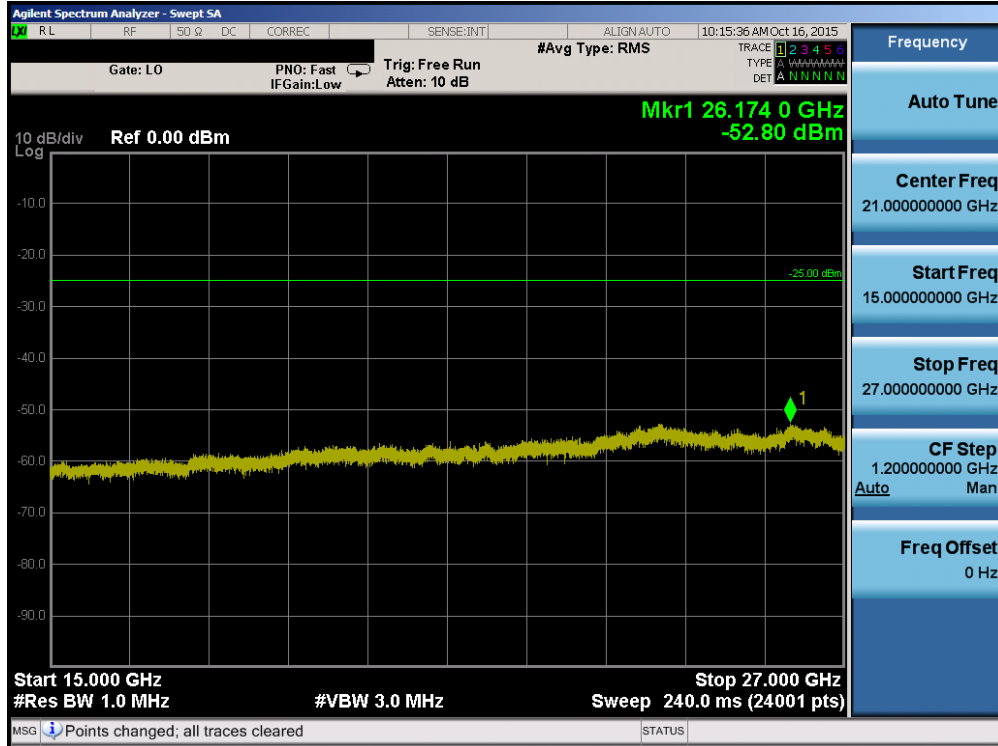

Plot 7-75. Conducted Spurious Plot (Band 41 – 15.0MHz QPSK – RB Size 1, RB Offset 0 – High Channel)

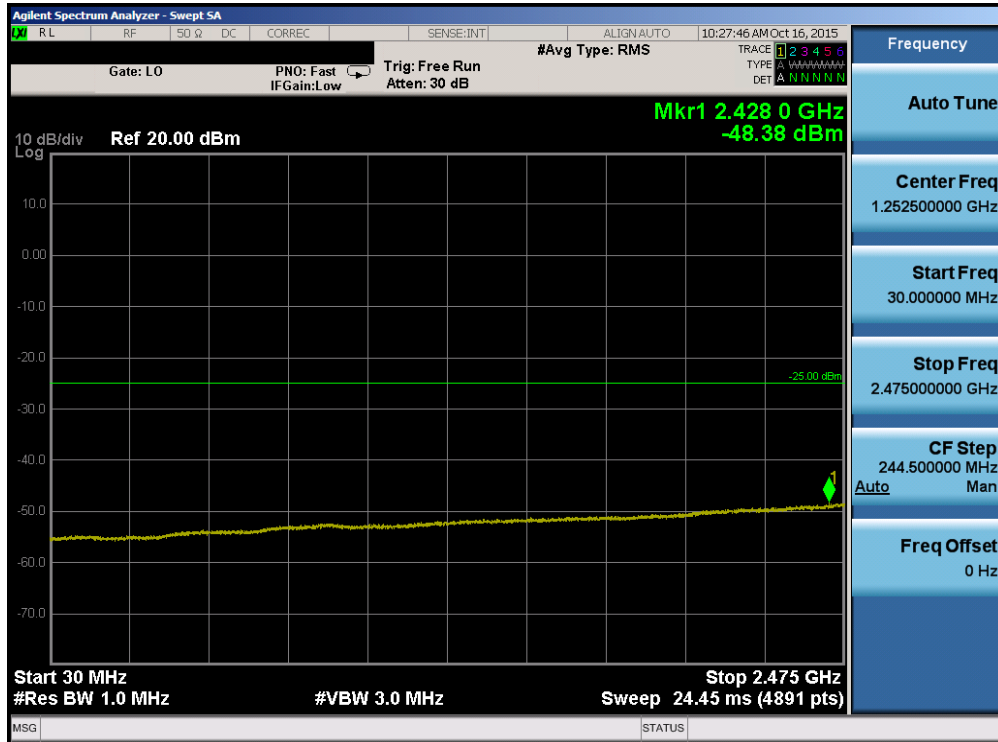

Plot 7-76. Conducted Spurious Plot (Band 41 – 20.0MHz QPSK – RB Size 1, RB Offset 0– Low Channel)

FCC ID: ZNFLS675		FCC Pt. 22, 24, & 27 LTE MEASUREMENT REPORT (CERTIFICATION)		Reviewed by: Quality Manager
Test Report S/N: 0Y1511161951.ZNF	Test Dates: 10/12-10/16/2015, 11/17 - 11/27/2015	EUT Type: Portable Handset		Page 53 of 110

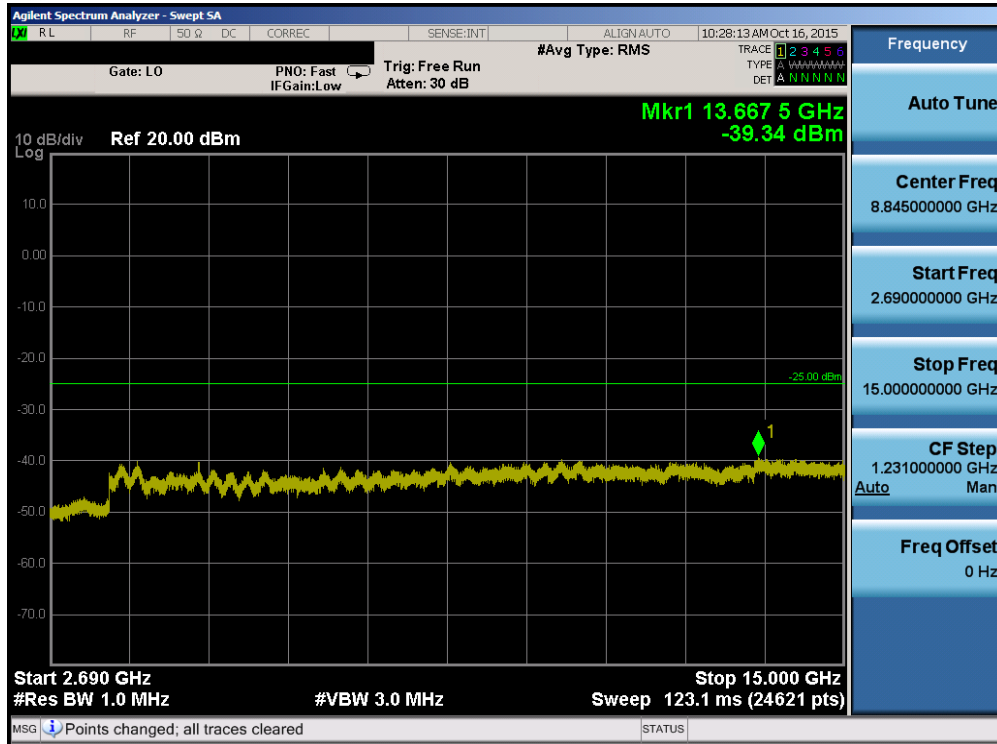

Plot 7-77. Conducted Spurious Plot (Band 41 – 20.0MHz QPSK – RB Size 1, RB Offset 0 – Low Channel)

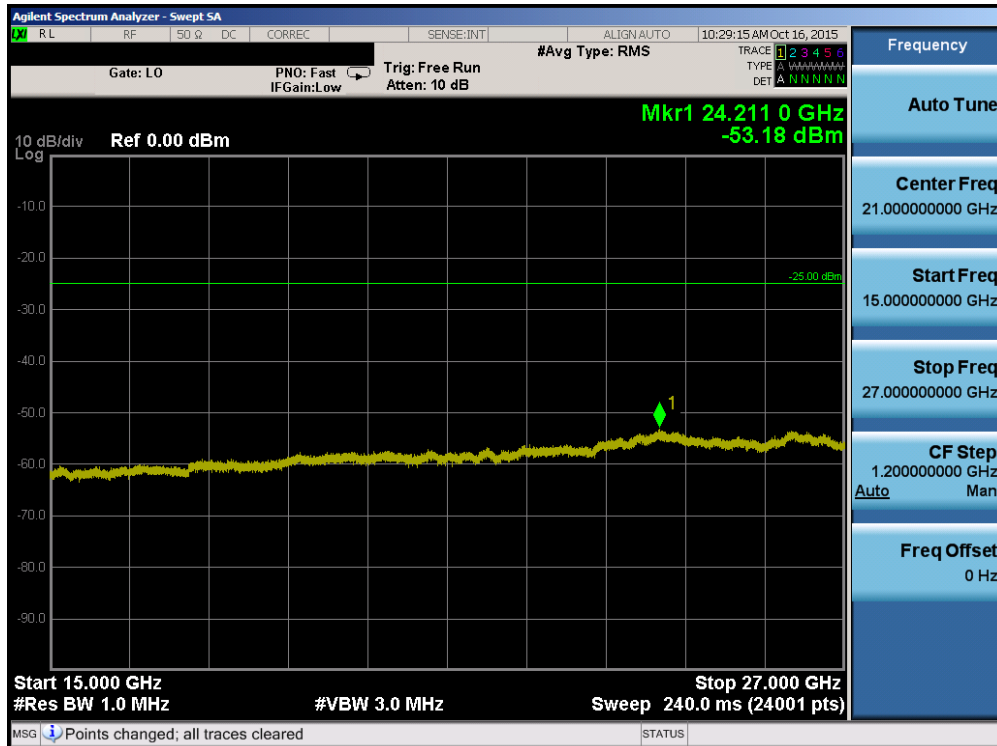

Plot 7-78. Conducted Spurious Plot (Band 41 – 20.0MHz QPSK – RB Size 1, RB Offset 0 – Low Channel)

FCC ID: ZNFLS675		FCC Pt. 22, 24, & 27 LTE MEASUREMENT REPORT (CERTIFICATION)		Reviewed by: Quality Manager
Test Report S/N: 0Y1511161951.ZNF	Test Dates: 10/12-10/16/2015, 11/17 - 11/27/2015	EUT Type: Portable Handset		Page 54 of 110

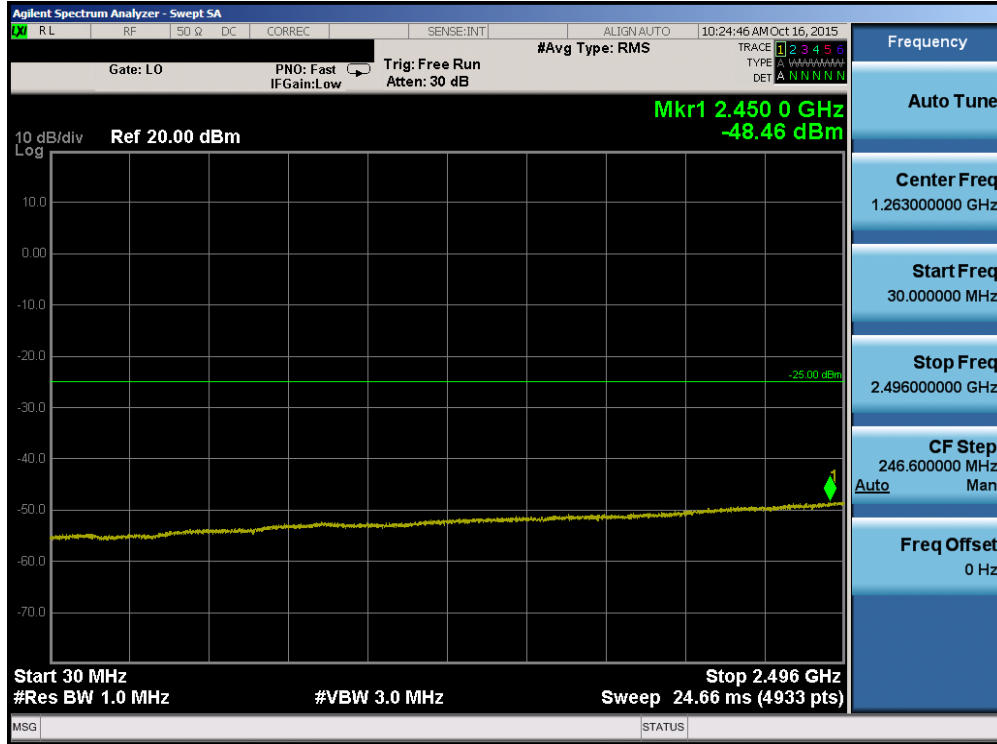

Plot 7-79. Conducted Spurious Plot (Band 41 – 20.0MHz QPSK – RB Size 1, RB Offset 0 – Mid Channel)

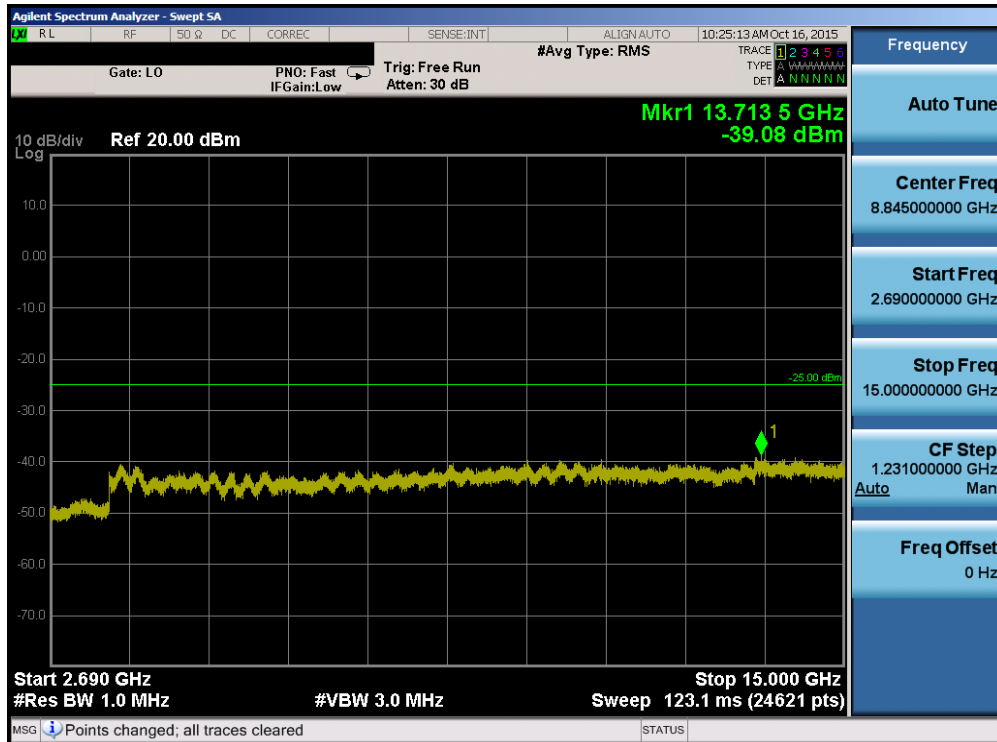

Plot 7-80. Conducted Spurious Plot (Band 41 – 20.0MHz QPSK – RB Size 1, RB Offset 0 – Mid Channel)

FCC ID: ZNFLS675		FCC Pt. 22, 24, & 27 LTE MEASUREMENT REPORT (CERTIFICATION)		Reviewed by: Quality Manager
Test Report S/N: 0Y1511161951.ZNF	Test Dates: 10/12-10/16/2015, 11/17 - 11/27/2015	EUT Type: Portable Handset		Page 55 of 110



Plot 7-81. Conducted Spurious Plot (Band 41 – 20.0MHz QPSK – RB Size 1, RB Offset 0 – Mid Channel)

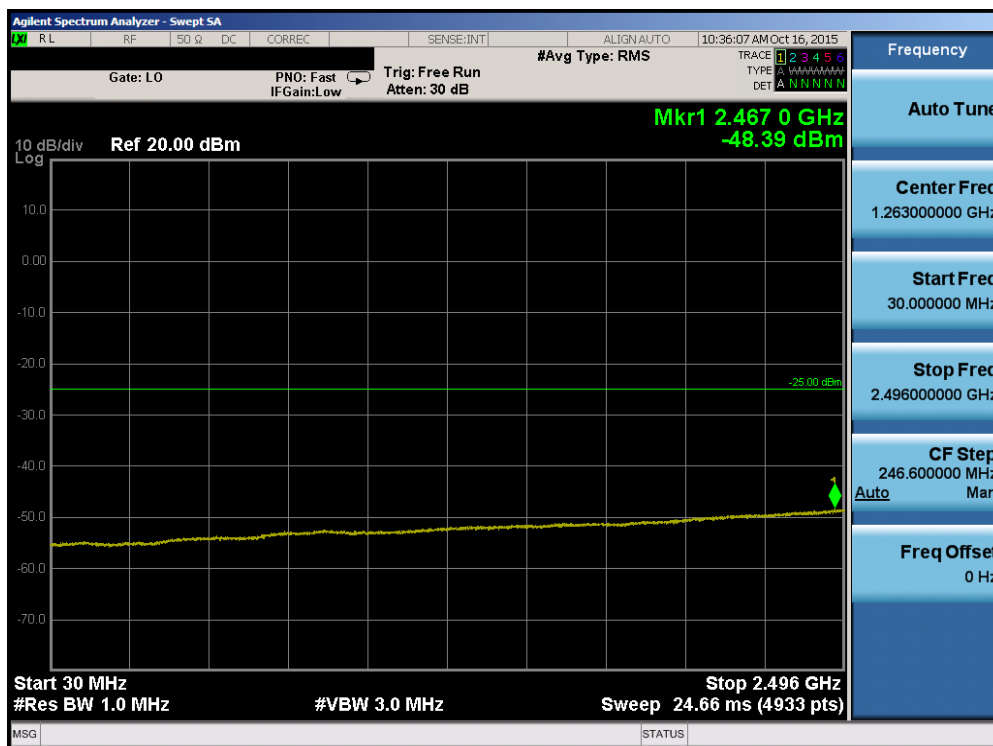

Plot 7-82. Conducted Spurious Plot (Band 41 – 20.0MHz QPSK – RB Size 1, RB Offset 0 – High Channel)

FCC ID: ZNFLS675		FCC Pt. 22, 24, & 27 LTE MEASUREMENT REPORT (CERTIFICATION)		Reviewed by: Quality Manager
Test Report S/N: 0Y1511161951.ZNF	Test Dates: 10/12-10/16/2015, 11/17 - 11/27/2015	EUT Type: Portable Handset		Page 56 of 110



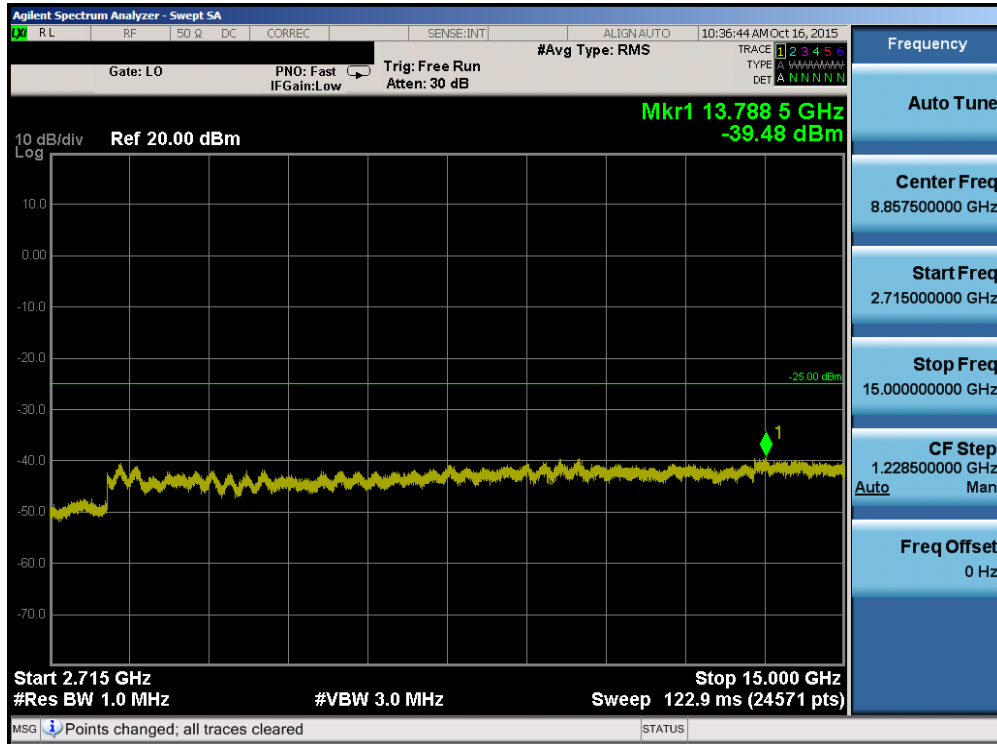

Plot 7-83. Conducted Spurious Plot (Band 41 – 20.0MHz QPSK – RB Size 1, RB Offset 0 – High Channel)

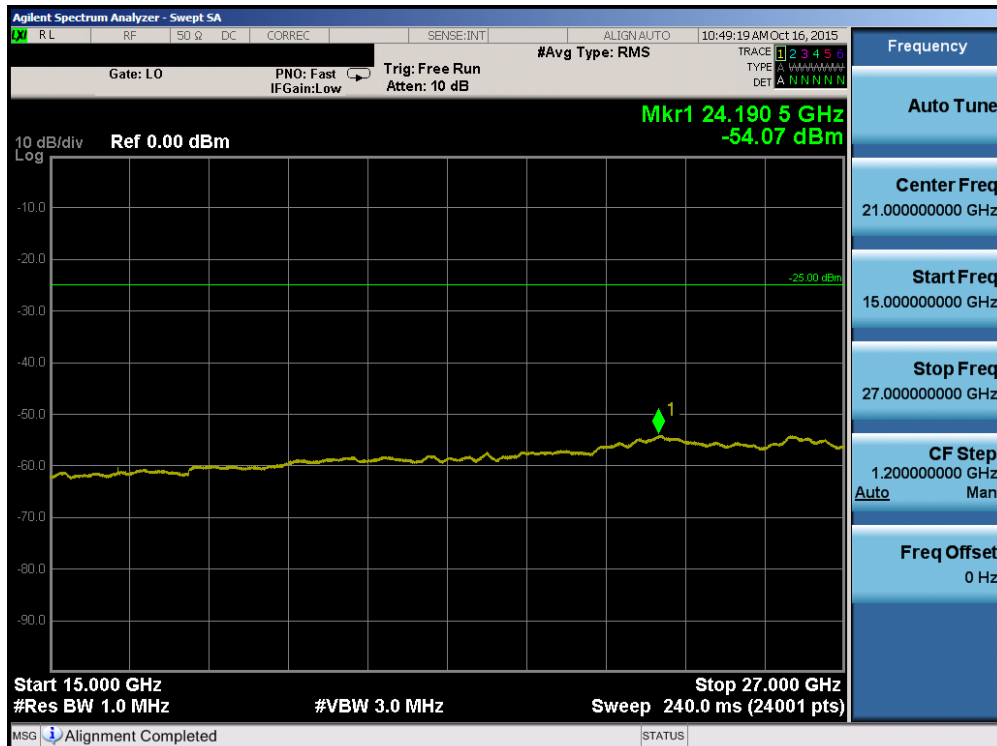

Plot 7-84. Conducted Spurious Plot (Band 41 – 20.0MHz QPSK – RB Size 1, RB Offset 0 – High Channel)

FCC ID: ZNFLS675		FCC Pt. 22, 24, & 27 LTE MEASUREMENT REPORT (CERTIFICATION)		Reviewed by: Quality Manager
Test Report S/N: 0Y1511161951.ZNF	Test Dates: 10/12-10/16/2015, 11/17 - 11/27/2015	EUT Type: Portable Handset		Page 57 of 110