



**FCC CFR47 PART 20.19
ANSI C63.19-2011**

**HAC RF EMISSIONS TEST REPORT
(CLASS II PERMISSIVE CHANGE)**

For
CDMA/LTE Phone + Bluetooth, DTS b/g/n

**Model: LG-LS660, LS660, LGLS660
FCC ID: ZNFLS660**

**REPORT NUMBER: 14U18507-S3A
ISSUE DATE: 9/2/2014**

Prepared for
**LG ELECTRONICS MOBILECOMM U.S.A., INC.
1000 SYLVAN AVE.
ENGLEWOOD CLIFFS, NJ 07632**

Prepared by
**UL VERIFICATION SERVICES INC.
47173 BENICIA STREET
FREMONT, CA 94538, U.S.A.
TEL: (510) 771-1000
FAX: (510) 661-0888**



NVLAP LAB CODE 200065-0

Revision History

<u>Rev.</u>	<u>Issue Date</u>	<u>Revisions</u>	<u>Revised By</u>
--	8/20/2014	Initial Issue	--
A	9/2/2014	Updated Title Page Updated Section 4.1: Corrected Calibration date	Nathan Sousa

Table of Contents

1. **Attestation of Test Results**..... 4

2. **Test Methodology** 5

3. **Facilities and Accreditation** 5

4. **Calibration and Uncertainty** 6

 4.1. *Measuring Instrument Calibration* 6

 4.2. *Measurement Uncertainty*..... 7

5. **Device Under Test**..... 8

 5.1. *Air Interfaces and Operating Mode* 8

6. **System Specifications** 9

7. **System Validation**..... 10

 7.1. *System Validation Results* 11

8. **Modulation Interference Factor (MIF)** 12

9. **Average Antenna Input Power** 13

10. **Evaluation for Low-power Exemption** 13

11. **HAC RF Emissions Test Procedure**..... 14

12. **RF Emissions Measurement Criteria** 17

13. **HAC (RF Emissions) Test Results** 18

 13.1. *Test Results Normal Battery Cover* 18

 13.2. *Worst Case RF Emission Test Plot* 19

14. **Appendixes** 20

 14.1. *System Validation Plots*..... 20

 14.2. *RF Emissions Test Plots* 20

 14.3. *Calibration Certificate for E-Field Probe ER3DV6 - SN 2339*..... 20

 14.4. *Calibration Certificate for Dipole CD835V3 - SN 1014*..... 20

 14.5. *Calibration Certificate for Dipole CD1880V3 - SN 1122*..... 20

 14.6. *UID 10295-AAA CDMA Specification* 20

 14.7. *MIF Attestation Letter* 20

 14.8. *Setup Photo* 20

1. Attestation of Test Results

Applicant name	LG ELECTRONICS MOBILECOMM U.S.A., INC.
DUT description	CDMA/LTE Phone + Bluetooth, DTS b/g/n
Model name	LG-LS660, LGLS660, LS660, LG-LS660P, LGLS660P, LG660P
Test device is	An identical prototype
Device category	Portable
Exposure category	General Population/Uncontrolled Exposure
Date tested	8/20/2014
HAC rating	M4
Applicable standard	ANSI C63.19-2011
Test Results	Pass

UL Verification Services Inc. tested the above equipment in accordance with the requirements set forth in the above standards. All indications of Pass/Fail in this report are opinions expressed by UL Verification Services Inc. based on interpretations and/or observations of test results. Measurement Uncertainties were not taken into account and are published for informational purposes only. The test results show that the equipment tested is capable of demonstrating compliance with the requirements as documented in this report.

Note: The results documented in this report apply only to the tested sample, under the conditions and modes of operation as described herein. This document may not be altered or revised in any way unless done so by UL Verification Services Inc. and all revisions are duly noted in the revisions section. Any alteration of this document not carried out by UL Verification Services Inc. will constitute fraud and shall nullify the document. This report must not be used by the client to claim product certification, approval, or endorsement by NVLAP, NIST, any agency of the Federal Government, or any agency of any government (NIST Handbook 150, Annex A). This report is written to support regulatory compliance of the applicable standards stated above.

Approved & Released By:

Prepared By:



Dave Weaver
 Program Manager
 UL Verification Services Inc.

Nathan Sousa
 Laboratory Engineer
 UL Verification Services Inc.

2. Test Methodology

The tests documented in this report were performed in accordance with ANSI C63.19-2011 Methods of Measurement of Compatibility between Wireless Communications Devices and Hearing Aids, FCC published KDB 285076 D01 HAC Guidance v04 and TCB workshop updates.

3. Facilities and Accreditation

The test sites and measurement facilities used to collect data are located at

47173 Benicia Street	47266 Benicia Street
SAR Lab C	SAR Lab 2

UL Verification Services Inc. is accredited by NVLAP, Laboratory Code 200065-0. The full scope of accreditation can be viewed at <http://ts.nist.gov/standards/scopes/2000650.htm>

4. Calibration and Uncertainty

4.1. Measuring Instrument Calibration

The measuring equipment utilized to perform the tests documented in this report has been calibrated in accordance with the manufacturer's recommendations, and is traceable to recognized national standards.

Name of Equipment	Manufacturer	Type/Model	Serial No.	Cal. Due date		
				MM	DD	Year
HP Signal Generator	HP	8665B	3546A00784	6	23	2015
Power Meter	HP	437B	3125U16345	6	16	2015
Power Meter	HP	437B	3125U09516	9	30	2014
Power Sensor	Agilent	8481A	2237A31744	10	22	2014
Amplifier	MITEQ	AMF-4D-00400600-50-30P	1808939	N/A		
Bi-directional coupler	Werlatone, Inc.	C8060-102	2710	N/A		
DC Power Supply	Sorensen Ametek	XT15-4	1319A02778	N/A		
Robot - Six Axes	Stäubli	TX90 XL	N/A	N/A		
Robot Remote Control	Stäubli	CS8C	N/A	N/A		
DASY5 Measurement Server	SPEAG	SEUMS001BA	1041	N/A		
Probe Alignment Unit	SPEAG	LB (V2)	261	N/A		
Data Acquisition Electronics	SPEAG	DAE4	1359	2	17	2015
Radio Communication Tester	R & S	CMU 200	106301	7	28	2015
E-Field Probe	SPEAG	ER3DV6*	2339	2	14	2015
Calibration Dipole	SPEAG	CD835V3	1014	2	18	2015
Calibration Dipole	SPEAG	CD1880V3	1159	5	19	2015

*: According to SPEAG's Technical Report, "MIF Verification", Doc # TR-FB-12.09.04-1, issued date: 9/4/2012. E-field probes are calibrated with specified uncertainty according to ISO 17025 as described in their calibration certificate. The MIF according to the definition in ANSI C63.19 is specific for a modulation and can therefore be used as a constant value if the probe has been PMR calibrated.

4.2. Measurement Uncertainty

HAC Uncertainty Budget According to ANSI C63.19

Error Description	Uncertainty value (±%)	Probe Dist.	Div.	(Ci) E	(Ci) H	Std. Unc.(±%)	
						E	H
Measurement System							
Probe Calibration	5.1	N	1	1	1	5.1	5.10
Axial Isotropy	4.7	R	1.732	1	1	2.7	2.71
Sensor Displacement	16.5	R	1.732	1	0.145	9.5	1.38
Boundary Effects	2.4	R	1.732	1	1	1.4	1.39
Phantom Boundary Effects	7.2	R	1.732	1	0	4.1	0.00
Linearity	4.7	R	1.732	1	1	2.7	2.71
Scaling to PMR Calibration	10.0	R	1.732	1	1	2.8	5.77
System Detection Limit	1.0	R	1.732	1	1	0.6	0.58
Readout Electronics	0.3	N	1	1	1	0.3	0.30
Response Time	0.8	R	1.732	1	1	0.5	0.46
Integration Time	2.6	R	1.732	1	1	1.5	1.50
RF Ambient Conditions	3.0	R	1.732	1	1	1.7	1.73
RF Reflections	12.0	R	1.732	1	1	6.9	6.93
Probe Positioner	1.2	R	1.732	1	0.67	0.7	0.46
Probe Positioning	4.7	R	1.732	1	0.67	2.7	1.82
Extrapolation and Interpolation	1.0	R	1.732	1	1	0.6	0.58
Test sample Related							
Test Positioning Vertical	4.7	R	1.732	1	0.67	2.7	1.82
Test Positioning Lateral	1.0	R	1.732	1	1	0.6	0.58
Device Holder and Phantom	2.4	R	1.732	1	1	1.4	1.39
Power Drift	5.0	R	1.732	1	1	2.9	2.89
Phantom and Setup Related							
Phantom Thickness	2.4	R	1.732	1	0.67	1.4	0.93
Combined Std. Uncertainty						15.4	12.2
Expanded Std. Uncertainty on Power						30.8	24.4
Expanded Std. Uncertainty on Field						15.4	12.2
Notes for table							
1. N - Nomal							
2. R - Rectangular							
3. Div. - Divisor used to obtain standard uncertainty							
4. Ci - is te sensitivity coefficient							

5. Device Under Test

CDMA/LTE Phone + Bluetooth, DTS b/g/n	
Normal operation:	Held to head
Back Cover	<input checked="" type="checkbox"/> Normal Battery Cover <input type="checkbox"/> Normal Battery Cover with NFC <input type="checkbox"/> Wireless Charger Battery Cove <input type="checkbox"/> Wireless Charger Battery Cover with NFC (with Front Cover) <input type="checkbox"/> Wireless Charger Battery Cover with NFC (without Front Cover)

5.1. Air Interfaces and Operating Mode

Air-Interface	Bands (MHz)	Type Transport	HAC Tested	Simultaneous but not Tested	Concurrent HAC Tested or not Tested	Voice over digital Transport OTT Capability	Wi-Fi Low Power	Additional GSM Power Reduction
LTE	Band 25 (1900)	VD	No ^{2,3}	Yes – Wi-Fi/BT	Not tested ^{2,3}	Yes	NA	NA
LTE	Band 26 (850)	VD	No ^{2,3}	Yes – Wi-Fi/BT	Not tested ^{2,3}	Yes	NA	NA
LTE	Band 41 (2600)	VD	No ^{2,3}	Yes – Wi-Fi/BT	Not tested ^{2,3}	Yes	NA	NA
CDMA	BC0 (850)	VD	Yes	Yes – LTE, Wi-Fi/BT	Not tested ¹	NA	NA	NA
CDMA	BC1 (1900)	VD	Yes	Yes – LTE, Wi-Fi/BT	Not tested ¹	NA	NA	NA
CDMA	BC10 (800)	VD	Yes	Yes – LTE, Wi-Fi/BT	Not tested ¹	NA	NA	NA
CDMA	EVDO	DT	No	Yes – Wi-Fi/BT	Not tested ¹	NA	NA	NA
Wi-Fi	2400	DT	No	Yes – GSM, WCDMA, CDMA, or LTE	Not tested ¹	NA	No	NA
BT	2400	DT	No	Yes – GSM, WCDMA, CDMA, or LTE	Not tested ¹	NA	NA	NA

Type Transport
 VO = Voice only
 DT = Digital Transport
 VD = CMRS and Data transport (HAC Tested)

Note:
 1. No concurrent mode was found to be the Worst Case mode
 2. CMRS VoLTE for M and T rating was not done because instrumentation for testing VoLTE was not available for T-Coil testing at the time testing was done and it is expected to have operational test instrumentation by the 3rd Quarter of year 2014.
 3. No associated T-Coil measurement has been made in accordance with 285076 D02 T-Coil testing for CMRS IP from October 2013 TCB workshop.

6. System Specifications

E-field measurements are performed using the DASY5 automated dosimetric assessment system. The DASY5 is made by Schmid & Partner Engineering AG (SPEAG) in Zurich, Switzerland.

The DASY5 HAC Extension consists of the following parts:

Test Arch Phantom

The specially designed Test Arch allows high precision positioning of both the device and any of the validation dipoles.

ER3DV6 Isotropic E-Field Probe

Construction:	One dipole parallel, two dipoles normal to probe axis Built-in shielding against static charges PEEK enclosure material (resistant to organic solvents, e.g., glycoether)
Calibration:	In air from 100 MHz to 3.0 GHz (absolute accuracy $\pm 6.0\%$, $k=2$)
Frequency:	100 MHz to > 6 GHz; Linearity: ± 0.2 dB (100 MHz to 3 GHz)
Directivity:	± 0.2 dB in air (rotation around probe axis) ± 0.4 dB in air (rotation normal to probe axis)
Dynamic Range:	2 V/m to > 1000 V/m; Linearity: ± 0.2 dB
Dimensions:	Overall length: 330 mm (Tip: 16 mm) Tip diameter: 8 mm (Body: 12 mm) Distance from probe tip to dipole centers: 2.5 mm The closest part of the sensor element is 1.1 mm closer to the tip
Application:	General near-field measurements up to 6 GHz Field component measurements

7. System Validation

The test setup was validated when first configured and verified periodically thereafter to ensure proper function. The procedure provided in this section is a validation procedure using dipole antennas for which the field levels were computed by numeric modeling.

Procedure

Place a dipole antenna meeting the requirements given in ANSI C63.19-2011 in the normally occupied by the WD.

The dipole antenna serves as a known source for an electrical and magnetic output. Position the E-field probe so that the following occurs:

- The probes and their cables are parallel to the coaxial feed of the dipole antenna
- The probe cables and the coaxial feed of the dipole antenna approach the measurement area from opposite directions
- The center point of the probe element(s) is 15 mm from the closest surface of the dipole elements.

Scan the length of the dipole with the E-field probe and record the two maximum values found near the dipole ends. Average the two readings and compare the reading to the expected value in the calibration certificate or the expected value in this standard.

Setup diagram

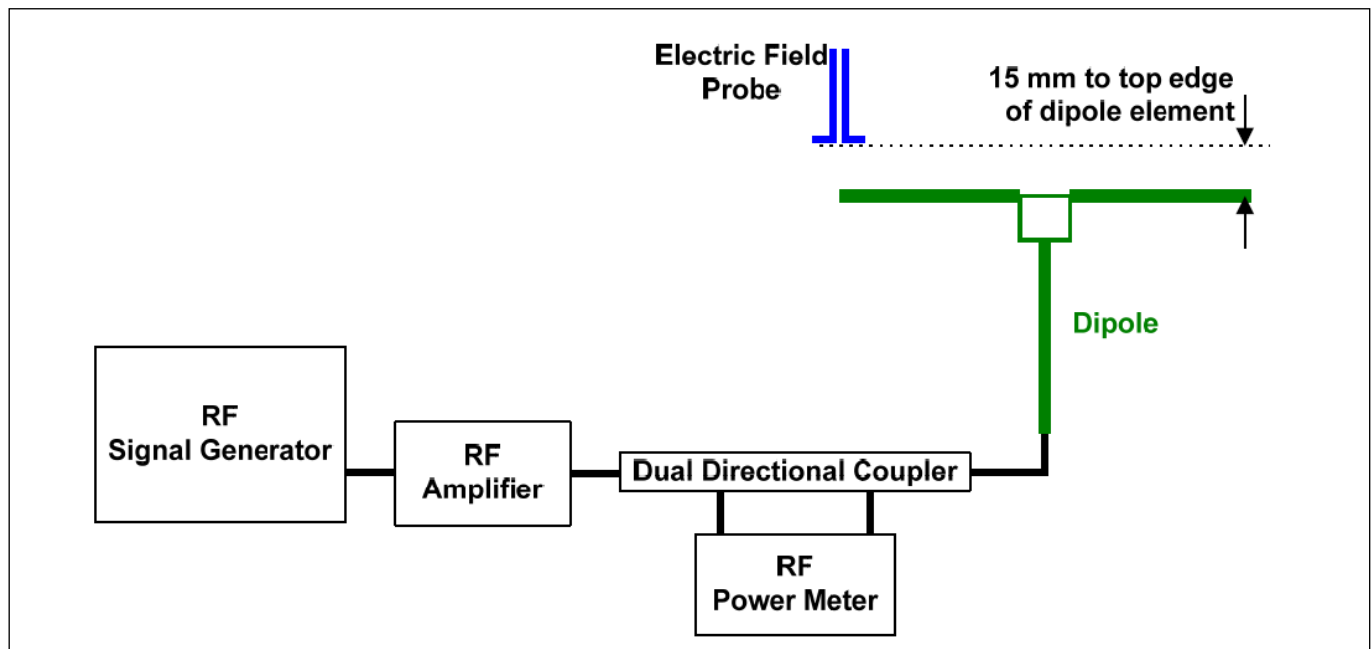

7.1. System Validation Results

E-field Probe ER3DV6 SN2339							
Calibration Dipole	f (MHz)	Input Power (mW)	Max. measured from		Average max. above arm (V/m)	E-field Target Values (V/m) (From SPEAG)	Deviation ¹⁾ (%)
			above high end (V/m)	above low end (V/m)			
CD835V3 SN 1014	835	100	110.00	108.10	109.05	108.3	0.69
CD1880V3 SN 1159	1880	100	85.82	89.65	87.74	89.4	-1.86

Notes:

- 1) Delta (Deviation) % = 100 * (Measured value minus Target value) divided by the Target value. Deltas within ±25% are acceptable, of which 12% is deviation and 13% is measurement uncertainty.
- 2) The maximum E-field or were evaluated and compared to the target values provided by SPEAG in the calibration certificate of specific dipoles.
- 3) Please refer to the appendix for detailed measurement data and plots.

8. Modulation Interference Factor (MIF)

The HAC Standard ANSI C63.19-2011 defines a new scaling using the Modulation Interference Factor (MIF) which replaces the need for the Articulation Weighting Factor (AWF) during the evaluation and is applicable to any modulation scheme.

The Modulation Interference factor (MIF, in dB) is added to the measured average E-field (in dBV/m) and converts it to the RF Audio Interference level (in dBV/m). This level considers the audible amplitude modulation components in the RF E-field. CW fields without amplitude modulation are assumed to not interfere with the hearing aid electronics. Modulations without time slots and low fluctuations at low frequencies have low MIF values, TDMA modulations with narrow transmission and repetition rates of few 100 Hz have high MIF values and give similar classifications as ANSI C63-2007.

Definitions

ER3D, E-field probes have a bandwidth <10 kHz and can therefore not evaluate the RF envelope in the full audio band. DASY52 is therefore using the "indirect" measurement method according to ANSI C63.19-2011 which is the primary method. These near field probes read the averaged E-field measurement. Especially for the new high peak-to-average (PAR) signal types, the probes shall be linearized by probe modulation response (PMR) calibration in order to not overestimate the field reading.

The evaluation method or the MIF is defined in ANSI C63.19-2011 section D.7. An RMS demodulated RF signal is fed to a spectral filter (similar to an A weighting filter) and forwarded to a temporal filter acting as a quasi-peak detector. The averaged output of these filtering is called to a 1 kHz 80% AM signal as reference. MIF measurement requires additional instrumentation and is not well suited for evaluation by the end user with reasonable uncertainty. It may alternatively be determined through analysis and simulation, because it is constraint and characteristic for a communication signal. DASY52 uses well defined signals for PMR calibration. The MIF of these signals has been determined by simulation and is automatically applied.

MIF values were not tested by a probe or as specified in the standards but are based on analysis provided by SPEAG for all the air interfaces (GSM, WCDMA, CDMA, LTE). For GSM, User Identifier (UID) 10021 was used; for WCDMA, UID 10011 was used; for CDMA, UID 10295 was used; for LTE, UID 10170 & 10176 were used. The data included in this report are for the worst case operating modes.

UID	Communication System Name	MIF (dB)
10295-AAA	CDMA2000 (1xRTT, RC1, SO3, 1/8 th Rate 25 fr.)	3.26

A PMR calibrated probe is linearized for the selected waveform over the full dynamic range within the uncertainty specified in its calibration certificate. ER3D, EF3D and EU2D E-field probes have a bandwidth <10 kHz and can therefore not evaluate the RF envelope in the full audio band. DASY52 is therefore using the "indirect" measurement method according to ANSI C63.19-2011 which is the primary method. These near field probes read the averaged E-field measurement. Especially for the new high peak-to-average (PAR) signal types, the probes shall be linearized by PMR calibration in order to not overestimate the field reading.

The MIF measurement uncertainty is estimated as follows, for modulation frequencies from slotted waveforms with fundamental frequency and at least 2 harmonics within 10 kHz:

- 0.2 dB for MIF -7 to +5 dB,
- 0.5 dB for MIF -13 to +11 dB
- 1 dB for MIF > -20 dB

9. Average Antenna Input Power

Air-Interface	Average Power (dBm)	
	Target	Max. Tune-up Limit
CDMA BC0	24.7	25.2
CDMA BC1	24.0	24.5
CDMA BC10	24.7	25.2

10. Evaluation for Low-power Exemption

An RF air interface technology of a device is exempt from testing when its average antenna input power plus its MIF is ≤ 17 dBm for any of its operating modes. If a device supports multiple RF air interfaces, each RF air interface shall be evaluated individually.

Air-Interface	Average Antenna Input Power (dBm) ¹	MIF (dB)	Input Power plus its MIF (dBm)	HAC Tested
CDMA BC0	25.2	3.26	28.46	Yes
CDMA BC1	24.5	3.26	27.76	Yes
CDMA BC10	25.2	3.26	28.46	Yes

Note(s):

1. Max tune-up limit

Conclusions

RF Emission testing for this device is required for CDMA voice mode.

11. HAC RF Emissions Test Procedure

The following are step-by-step test procedures.

- a) Confirm proper operation of the field probe, probe measurement system and other instrumentation and the positioning system.
- b) Position the WD in its intended test position.
- c) Set the WD to transmit a fixed and repeatable combination of signal power and modulation characteristic that is representative of the worst case (highest interference potential) encountered in normal use. Transiently occurring start-up, changeover, or termination conditions, or other operations likely to occur less than 1% of the time during normal operation, may be excluded from consideration.
- d) The center sub-grid shall be centered on the T-Coil mode perpendicular measurement point or the acoustic output, as appropriate. Locate the field probe at the initial test position in the 50 mm by 50 mm grid, which is contained in the measurement plane, refer to illustrated in Figure 1. If the field alignment method is used, align the probe for maximum field reception.
- e) Record the reading at the output of the measurement system
- f) Scan the entire 50 mm by 50 mm region in equally spaced increments and record the reading at each measurement point. The distance between measurement points shall be sufficient to assure the identification of the maximum reading.
- g) Identify the five contiguous sub-grids around the center sub-grid whose maximum reading is the lowest of all available choices. This eliminates the three sub-grids with the maximum readings. Thus, the six areas to be used to determine the WD's highest emissions are identified.
- h) Identify the maximum reading within the non-excluded sub-grids identified in step g).
- i) Convert the highest field reading within identified in step h) to RF audio interference level, in V/m, by taking the square root of the reading and then dividing it by the measurement system transfer function, established in 5.5.1.1. Convert this result to dB(V/m) by taking the base-10 logarithm and multiplying by 20.

Indirect measurement method

Replacing step i), the RF audio interference level in dB (V/m) is obtained by adding the MIF (in dB) to the maximum steady-state rms field-strength reading, in dB (V/m), from step h). Use this result to determine the category rating

- j) Compare this RF audio interference level with the categories in Clause 8 (ANSI C63.19-2011) and record the resulting WD category rating
- k) For the T-Coil mode M-rating assessment, determine whether the chosen perpendicular measurement point is contained in an included sub-grid of the first scan. If so, then a second scan is not necessary. The first scan and resultant category rating may be used for the T-Coil mode M rating.

Otherwise, repeat step a) through step i), with the grid shifted so that it is centered on the perpendicular measurement point. Record the WD category rating.

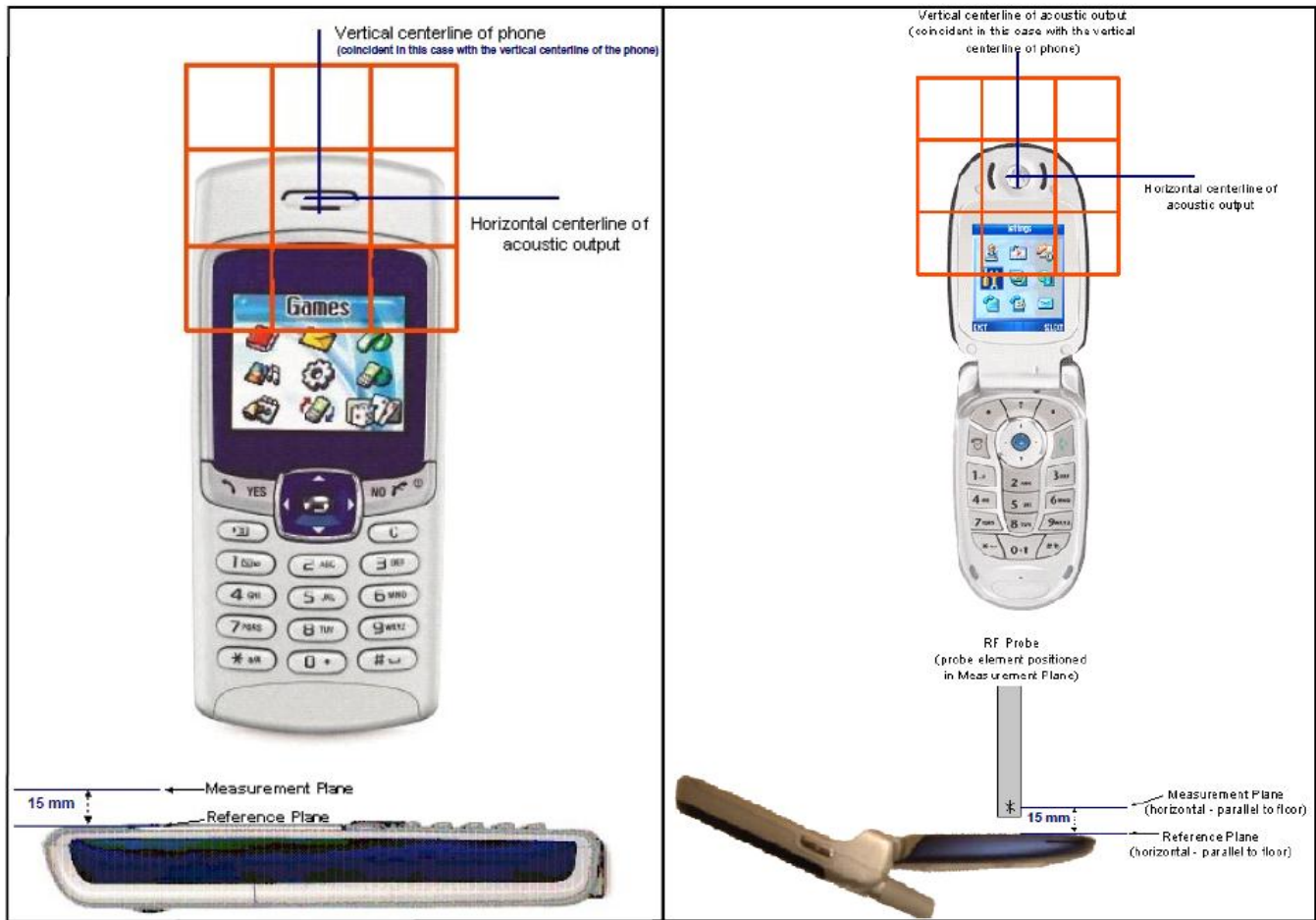
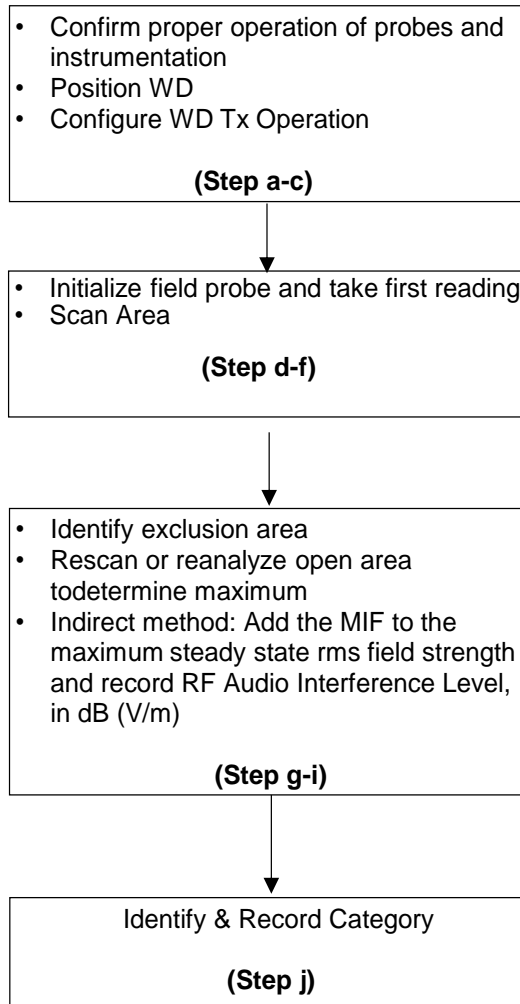

Figure 1 - WD reference and plane for RF emission measurements

Test flowchart Per ANSI-PC63.19 2011

Test Instructions



12. RF Emissions Measurement Criteria

WD RF audio interference level categories in logarithmic units

Emission Categories	E-field emissions	
	< 960 MHz	> 960 MHz
Category M1	50 to 55 dB (V/m)	40 to 45 dB (V/m)
Category M2	45 to 50 dB (V/m)	35 to 40 dB (V/m)
Category M3	40 to 45 dB (V/m)	30 to 35 dB (V/m)
Category M4	<40 dB (V/m)	<30 dB (V/m)

13. HAC (RF Emissions) Test Results

MIF values were not tested by a probe or as specified in the standards but are based on analysis provided by SPEAG for the following User Identifiers and air interfaces.

UID	Communication System Name	MIF (dB)
10295-AAA	CDMA2000 (1xRTT, RC1, SO3, 1/8 th Rate 25 fr.)	3.26

The data included in this report are for the worst case operating modes. Refer to a separate attestation letter signed by the grantee that the MIF vales represent worst case operation modes.

13.1. Test Results Normal Battery Cover

Air-Interface	Ch. No.	Freq. (MHz)	Results* (dB V/m)	M-Rating	Plots Page #
CDMA2000 BC0 SO3 RC1	1013	824.7	29.31	M4	1
	384	836.52	31.51**	M4**	2
	777	848.31	29.23	M4	3
CDMA2000 BC1 SO3 RC1	25	1851.25	24.51	M4	4
	600	1880	23.09	M4	5
	1175	1908.75	23.34	M4	6

Note(s):

- *: Measured Audio Interference level in dB (V/m): indirect method (max rms field strength Plus MIF)
- **:. According to the last paragraph of Section 8, the MIF measurement uncertainty is estimated to be 0.2 dB for MIF -7 to + 5 dB. The maximum E-field result of 31.51 dB V/m plus measurement uncertainty of 0.2 dB is 31.71 dB V/m, which is still within M4 rating.

13.2. Worst Case RF Emission Test Plot

Test Laboratory: UL Verification Services Inc., SAR Lab 2

Date: 8/20/2014

HAC-RF Emission

Communication System: UID 10295 - AAB, CDMA2000, RC1, SO3, 1/8th Rate 25 fr.; Frequency: 831.99 MHz; Duty Cycle: 1:17.7419

Phantom section: RF Section

DASY5 Configuration:

- Probe: ER3DV6 - SN2339; ConvF(1, 1, 1); Calibrated: 2/14/2014;
- Sensor-Surface: (Fix Surface)
- Electronics: DAE4 Sn1359; Calibrated: 2/17/2014
- Phantom: HAC Test Arch with AMCC; Type: SD HAC P01 BB
- Measurement SW: DASY52, Version 52.8 (7); SEMCAD X Version 14.6.10 (7164)

CDMA BC0 E-Field measurement/RC1_SO3_Ch 384/Hearing Aid Compatibility Test (101x101x1):

Interpolated grid: dx=0.5000 mm, dy=0.5000 mm

Device Reference Point: 0, 0, -6.3 mm

Reference Value = 36.57 V/m; Power Drift = -1.19 dB

Applied MIF = 3.26 dB

RF audio interference level = 31.51 dBV/m

Emission category: **M4**

MIF scaled E-field		
Grid 1 M4 30.29 dBV/m	Grid 2 M4 30.93 dBV/m	Grid 3 M4 29.92 dBV/m
Grid 4 M4 30.83 dBV/m	Grid 5 M4 31.51 dBV/m	Grid 6 M4 31.26 dBV/m
Grid 7 M4 31.1 dBV/m	Grid 8 M4 31.69 dBV/m	Grid 9 M4 31.33 dBV/m

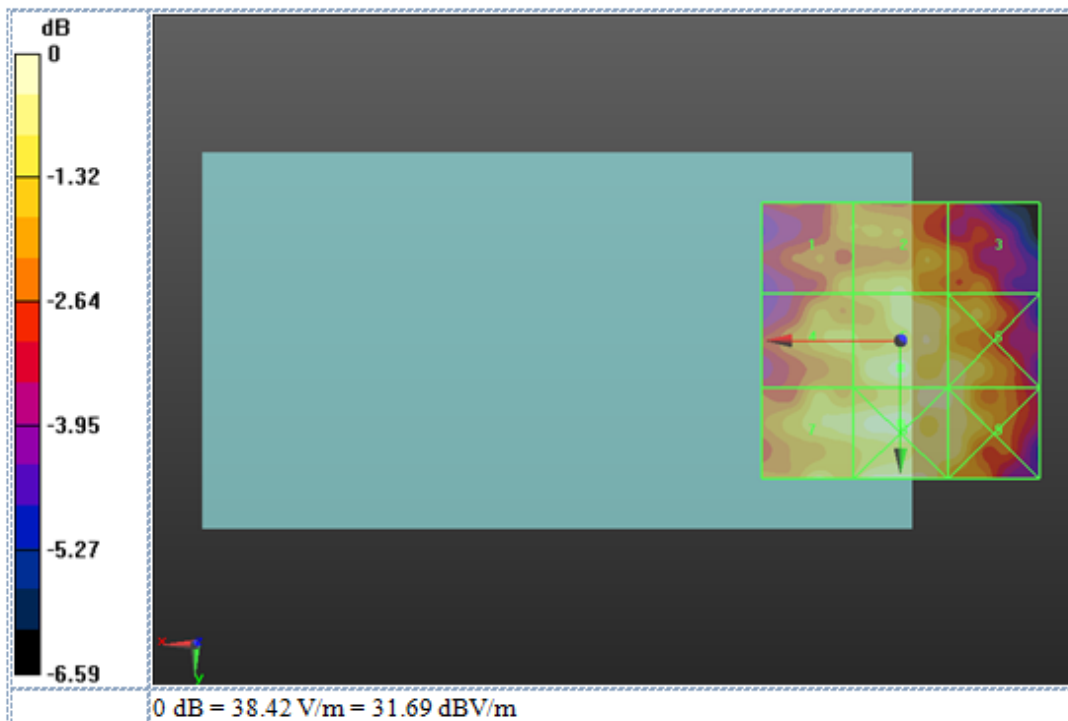

14. Appendixes

Refer to separated files for the following appendixes

14.1. System Validation Plots

14.2. RF Emissions Test Plots

14.3. Calibration Certificate for E-Field Probe ER3DV6 - SN 2339

14.4. Calibration Certificate for Dipole CD835V3 - SN 1014

14.5. Calibration Certificate for Dipole CD1880V3 - SN 1159

14.6. UID 10295-AAA CDMA Specification

14.7. MIF Attestation Letter

14.8. Setup Photo

END OF REPORT