



SAR EVALUATION REPORT

Applicant Name:
 LG Electronics MobileComm U.S.A., Inc.
 1000 Sylvan Avenue
 Englewood Cliffs, NJ 07632
 United States

Date of Testing:
 04/05/16 - 04/11/16
Test Site/Location:
 PCTEST Lab, Columbia, MD, USA
Document Serial No.:
 0Y1604060711-R1.ZNF

FCC ID: ZNFLS450

APPLICANT: LG ELECTRONICS MOBILECOMM U.S.A., INC.

DUT Type: Portable Handset
Application Type: Certification
FCC Rule Part(s): CFR §2.1093
Model(s): LG-LS450, LGLS450, LS450

Equipment Class	Band & Mode	Tx Frequency	SAR		
			1 gm Head (W/kg)	1 gm Body-Worn (W/kg)	1 gm Hotspot (W/kg)
PCE	CDMA/EVDO BC10 (§90S)	817.90 - 823.10 MHz	0.50	0.95	0.97
PCE	CDMA/EVDO BC0 (§22H)	824.70 - 848.31 MHz	0.60	0.92	0.92
PCE	PCS CDMA/EVDO	1851.25 - 1908.75 MHz	0.73	0.89	0.90
PCE	GSM/GPRS/EDGE 850	824.20 - 848.80 MHz	0.66	0.98	0.98
PCE	GSM/GPRS/EDGE 1900	1850.20 - 1909.80 MHz	0.35	0.39	0.39
PCE	UMTS 850	826.40 - 846.60 MHz	0.42	0.59	0.59
PCE	UMTS 1750	1712.4 - 1752.6 MHz	0.47	1.01	1.01
PCE	UMTS 1900	1852.4 - 1907.6 MHz	0.57	0.80	0.80
PCE	LTE Band 12	699.7 - 715.3 MHz	0.25	0.46	0.46
PCE	LTE Band 26 (Cell)	814.7 - 848.3 MHz	0.43	0.71	0.71
PCE	LTE Band 5 (Cell)	824.7 - 848.3 MHz	N/A	N/A	N/A
PCE	LTE Band 4 (AWS)	1710.7 - 1754.3 MHz	0.41	0.98	0.98
PCE	LTE Band 25 (PCS)	1850.7 - 1914.3 MHz	0.51	0.59	0.59
PCE	LTE Band 2 (PCS)	1850.7 - 1909.3 MHz	N/A	N/A	N/A
PCE	LTE Band 41	2498.5 - 2687.5 MHz	0.44	0.38	0.38
DTS	2.4 GHz WLAN	2412 - 2462 MHz	0.61	0.12	0.12
DSS/DTS	Bluetooth	2402 - 2480 MHz	N/A		
Simultaneous SAR per KDB 690783 D01v01r03:			1.34	1.18	1.13

Note: This revised Test Report (S/N: 0Y1604060711-R1.ZNF) supersedes and replaces the previously issued test report on the same subject device for the same type of testing as indicated. Please discard or destroy the previously issued test report(s) and dispose of it accordingly.

This wireless portable device has been shown to be capable of compliance for localized specific absorption rate (SAR) for uncontrolled environment/general population exposure limits specified in ANSI/IEEE C95.1-1992 and has been tested in accordance with the measurement procedures specified in Section 1.7 of this report; for North American frequency bands only.

I attest to the accuracy of data. All measurements reported herein were performed by me or were made under my supervision and are correct to the best of my knowledge and belief. I assume full responsibility for the completeness of these measurements and vouch for the qualifications of all persons taking them. Test results reported herein relate only to the item(s) tested.

Randy Ortanez
 President





The SAR Tick is an initiative of the Mobile Manufacturers Forum (MMF). While a product may be considered eligible, use of the SAR Tick logo requires an agreement with the MMF. Further details can be obtained by emailing: sartick@mmfai.info.

FCC ID: ZNFLS450		SAR EVALUATION REPORT		Reviewed by: Quality Manager
Document S/N: 0Y1604060711-R1.ZNF	Test Dates: 04/05/16 - 04/11/16	DUT Type: Portable Handset		Page 1 of 59

TABLE OF CONTENTS

1	DEVICE UNDER TEST	3
2	LTE INFORMATION	8
3	INTRODUCTION	9
4	DOSIMETRIC ASSESSMENT	10
5	DEFINITION OF REFERENCE POINTS	11
6	TEST CONFIGURATION POSITIONS	12
7	RF EXPOSURE LIMITS	15
8	FCC MEASUREMENT PROCEDURES.....	16
9	RF CONDUCTED POWERS	22
10	SYSTEM VERIFICATION.....	36
11	SAR DATA SUMMARY	38
12	FCC MULTI-TX AND ANTENNA SAR CONSIDERATIONS.....	51
13	SAR MEASUREMENT VARIABILITY	54
14	EQUIPMENT LIST.....	55
15	MEASUREMENT UNCERTAINTIES.....	56
16	CONCLUSION.....	57
17	REFERENCES	58
APPENDIX A: SAR TEST PLOTS		
APPENDIX B: SAR DIPOLE VERIFICATION PLOTS		
APPENDIX C: PROBE AND DIPOLE CALIBRATION CERTIFICATES		
APPENDIX D: SAR TISSUE SPECIFICATIONS		
APPENDIX E: SAR SYSTEM VALIDATION		
APPENDIX F: DUT ANTENNA DIAGRAM & SAR TEST SETUP PHOTOGRAPHS		

FCC ID: ZNFLS450	 PCTEST ENGINEERING LABORATORY, INC.	SAR EVALUATION REPORT		Reviewed by: Quality Manager
Document S/N: OY1604060711-R1.ZNF	Test Dates: 04/05/16 - 04/11/16	DUT Type: Portable Handset	Page 2 of 59	

1 DEVICE UNDER TEST

1.1 Device Overview

Band & Mode	Operating Modes	Tx Frequency
CDMA/EVDO BC10 (§90S)	Voice/Data	817.90 - 823.10 MHz
CDMA/EVDO BC0 (§22H)	Voice/Data	824.70 - 848.31 MHz
PCS CDMA/EVDO	Voice/Data	1851.25 - 1908.75 MHz
GSM/GPRS/EDGE 850	Voice/Data	824.20 - 848.80 MHz
GSM/GPRS/EDGE 1900	Voice/Data	1850.20 - 1909.80 MHz
UMTS 850	Voice/Data	826.40 - 846.60 MHz
UMTS 1750	Voice/Data	1712.4 - 1752.6 MHz
UMTS 1900	Voice/Data	1852.4 - 1907.6 MHz
LTE Band 12	Data	699.7 - 715.3 MHz
LTE Band 26 (Cell)	Data	814.7 - 848.3 MHz
LTE Band 5 (Cell)	Data	824.7 - 848.3 MHz
LTE Band 4 (AWS)	Data	1710.7 - 1754.3 MHz
LTE Band 25 (PCS)	Data	1850.7 - 1914.3 MHz
LTE Band 2 (PCS)	Data	1850.7 - 1909.3 MHz
LTE Band 41	Data	2498.5 - 2687.5 MHz
2.4 GHz WLAN	Data	2412 - 2462 MHz
Bluetooth	Data	2402 - 2480 MHz

1.2 Power Reduction for SAR



There is no power reduction used for any band/mode implemented in this device for SAR purposes.

1.3 Nominal and Maximum Output Power Specifications

This device operates using the following maximum and nominal output power specifications. SAR values were scaled to the maximum allowed power to determine compliance per KDB Publication 447498 D01v06.

Mode / Band		Modulated Average (dBm)
CDMA/EVDO BC10 (§90S)	Maximum	25.0
	Nominal	24.5
CDMA/EVDO BC0 (§22H)	Maximum	24.7
	Nominal	24.2
PCS CDMA/EVDO	Maximum	24.4
	Nominal	23.9



Mode / Band		Voice (dBm)	Burst Average GMSK (dBm)		Burst Average 8-PSK (dBm)	
		1 TX Slot	1 TX Slots	2 TX Slots	1 TX Slots	2 TX Slots
GSM/GPRS/EDGE 850	Maximum	33.2	33.2	31.7	27.7	26.7
	Nominal	32.7	32.7	31.2	27.2	26.2
GSM/GPRS/EDGE 1900	Maximum	30.2	30.2	27.7	26.7	25.7
	Nominal	29.7	29.7	27.2	26.2	25.2

FCC ID: ZNFLS450		SAR EVALUATION REPORT			Reviewed by: Quality Manager
Document S/N: 0Y1604060711-R1.ZNF	Test Dates: 04/05/16 - 04/11/16	DUT Type: Portable Handset		Page 3 of 59	

Mode / Band		Modulated Average (dBm)		
		3GPP WCDMA	3GPP HSDPA	3GPP HSUPA
UMTS Band 5 (850 MHz)	Maximum	23.7	23.7	23.7
	Nominal	23.2	23.2	23.2
UMTS Band 4 (1750 MHz)	Maximum	22.7	22.7	22.7
	Nominal	22.2	22.2	22.2
UMTS Band 2 (1900 MHz)	Maximum	23.7	23.7	23.7
	Nominal	23.2	23.2	23.2

Mode / Band		Modulated Average (dBm)
LTE Band 12	Maximum	24.8
	Nominal	24.3
LTE Band 26 (Cell)	Maximum	24.0
	Nominal	23.5
LTE Band 5 (Cell)	Maximum	23.7
	Nominal	23.2
LTE Band 4 (AWS)	Maximum	23.2
	Nominal	22.7
LTE Band 25 (PCS)	Maximum	23.7
	Nominal	23.2
LTE Band 2 (PCS)	Maximum	23.7
	Nominal	23.2
LTE Band 41	Maximum	23.5
	Nominal	23.0

Mode / Band		Modulated Average (dBm)
IEEE 802.11b (2.4 GHz)	Maximum	16.0
	Nominal	15.0
IEEE 802.11g (2.4 GHz)	Maximum	15.0
	Nominal	14.0
IEEE 802.11n (2.4 GHz)	Maximum	15.0
	Nominal	14.0
Bluetooth (1 Mbps)	Maximum	9.0
	Nominal	8.0
Bluetooth (2 Mbps)	Maximum	7.0
	Nominal	6.0
Bluetooth (3 Mbps)	Maximum	7.0
	Nominal	6.0
Bluetooth LE	Maximum	1.0
	Nominal	0.0

FCC ID: ZNFLS450	 PCTEST ENGINEERING LABORATORY, INC.	SAR EVALUATION REPORT		Reviewed by: Quality Manager
Document S/N: OY1604060711-R1.ZNF	Test Dates: 04/05/16 - 04/11/16	DUT Type: Portable Handset		Page 4 of 59

1.4 DUT Antenna Locations

The overall dimensions of this device are > 9 x 5 cm. The overall diagonal dimension of the device is ≤160 mm and the diagonal display is ≤150 mm. A diagram showing the location of the device antennas can be found in Appendix F.

**Table 1-1
Device Edges/Sides for SAR Testing**

Mode	Back	Front	Top	Bottom	Right	Left
EVDO BC10 (§90S)	Yes	Yes	No	Yes	Yes	Yes
EVDO BC0 (§22H)	Yes	Yes	No	Yes	Yes	Yes
PCS EVDO	Yes	Yes	No	Yes	No	Yes
GPRS 850	Yes	Yes	No	Yes	Yes	Yes
GPRS 1900	Yes	Yes	No	Yes	No	Yes
UMTS 850	Yes	Yes	No	Yes	Yes	Yes
UMTS 1750	Yes	Yes	No	Yes	No	Yes
UMTS 1900	Yes	Yes	No	Yes	No	Yes
LTE Band 12	Yes	Yes	No	Yes	Yes	Yes
LTE Band 26 (Cell)	Yes	Yes	No	Yes	Yes	Yes
LTE Band 4 (AWS)	Yes	Yes	No	Yes	No	Yes
LTE Band 25 (PCS)	Yes	Yes	No	Yes	No	Yes
LTE Band 41	Yes	Yes	No	Yes	Yes	Yes
2.4 GHz WLAN	Yes	Yes	Yes	No	No	Yes

Note: Particular DUT edges were not required to be evaluated for wireless router SAR if the edges were greater than 2.5 cm from the transmitting antenna according to FCC KDB Publication 941225 D06v02r01 Section III. The distances between the transmit antennas and the edges of the device are included in the filing.



1.5 Simultaneous Transmission Capabilities

According to FCC KDB Publication 447498 D01v06, transmitters are considered to be transmitting simultaneously when there is overlapping transmission, with the exception of transmissions during network hand-offs with maximum hand-off duration less than 30 seconds. Possible transmission paths for the DUT are shown in Figure 1-1 and are color-coded to indicate communication modes which share the same path. Modes which share the same transmission path cannot transmit simultaneously with one another.



**Figure 1-1
Simultaneous Transmission Paths**

This device contains multiple transmitters that may operate simultaneously, and therefore requires a simultaneous transmission analysis according to FCC KDB Publication 447498 D01v06 4.3.2 procedures.

FCC ID: ZNFLS450	 PCTEST PROFESSIONAL LABORATORY, INC.	SAR EVALUATION REPORT		Reviewed by: Quality Manager
Document S/N: OY1604060711-R1.ZNF	Test Dates: 04/05/16 - 04/11/16	DUT Type: Portable Handset	Page 5 of 59	

**Table 1-2
Simultaneous Transmission Scenarios**

No.	Capable Transmit Configuration	Head	Body-Worn Accessory	Wireless Router	Notes
1	1x CDMA voice + 2.4 GHz WI-FI	Yes	Yes	N/A	
2	1x CDMA voice + 2.4 GHz Bluetooth	N/A	Yes	N/A	
3	GSM voice + 2.4 GHz WI-FI	Yes	Yes	N/A	
4	GSM voice + 2.4 GHz Bluetooth	N/A	Yes	N/A	
5	UMTS + 2.4 GHz WI-FI	Yes	Yes	Yes	
6	UMTS + 2.4 GHz Bluetooth	N/A	Yes	N/A	
7	LTE + 2.4 GHz WI-FI	Yes*	Yes*	Yes	*-Pre-installed VOIP applications are considered.
8	LTE + 2.4 GHz Bluetooth	N/A	Yes*	N/A	*-Pre-installed VOIP applications are considered.
9	CDMA/EVDO data + 2.4 GHz WI-FI	Yes*	Yes*	Yes	*-Pre-installed VOIP applications are considered.
10	CDMA/EVDO data + 2.4 GHz Bluetooth	N/A	Yes*	N/A	*-Pre-installed VOIP applications are considered.
11	GPRS/EDGE + 2.4 GHz WI-FI	Yes*	Yes*	Yes	*-Pre-installed VOIP applications are considered.
12	GPRS/EDGE + 2.4 GHz Bluetooth	N/A	Yes*	N/A	*-Pre-installed VOIP applications are considered.

- 2.4 GHz WLAN, and 2.4 GHz Bluetooth share the same antenna path and cannot transmit simultaneously.
- All licensed modes share the same antenna path and cannot transmit simultaneously.
- When the user utilizes multiple services in UMTS 3G mode it uses multi-Radio Access Bearer or multi-RAB. The power control is based on a physical control channel (Dedicated Physical Control Channel [DPCCH]) and power control will be adjusted to meet the needs of both services. Therefore, the UMTS+WLAN scenario also represents the UMTS Voice/DATA + WLAN Hotspot scenario.
- Per the manufacturer, WIFI Direct is expected to be used in conjunction with a held-to-ear or body-worn accessory voice call.

1.6 Miscellaneous SAR Test Considerations

(A) WIFI/BT

Per FCC KDB 447498 D01v06, the 1g SAR exclusion threshold for distances <50mm is defined by the following equation:

$$\frac{\text{Max Power of Channel (mW)}}{\text{Test Separation Dist (mm)}} * \sqrt{\text{Frequency(GHz)}} \leq 3.0$$



Based on the maximum conducted power of Bluetooth (rounded to the nearest mW) and the antenna to user separation distance, body-worn Bluetooth SAR was not required; $[(8/10) * \sqrt{2.480}] = 1.3 < 3.0$. Per KDB Publication 447498 D01v06, the maximum power of the channel was rounded to the nearest mW before calculation.

(B) Licensed Transmitter(s)

CDMA 1X Advanced technology was not required for SAR since the maximum allowed output powers for 1x Advanced was not more than 0.25 dB higher than the maximum powers for 1x and the measured SAR in any 1x mode exposure conditions was not greater than 1.2 W/kg per FCC KDB Publication 941225 D01v03r01.

GSM/GPRS/EDGE DTM is not supported for US bands. Therefore, the GSM Voice modes in this report do not transmit simultaneously with GPRS/EDGE Data.

This device is only capable of QPSK HSUPA in the uplink. Therefore, no additional SAR tests are required beyond that described for devices with HSUPA in KDB 941225 D01v03r01.

FCC ID: ZNFLS450		SAR EVALUATION REPORT		Reviewed by: Quality Manager
Document S/N: 0Y1604060711-R1.ZNF	Test Dates: 04/05/16 - 04/11/16	DUT Type: Portable Handset		Page 6 of 59

LTE SAR for the higher modulations and lower bandwidths were not tested since the maximum average output power of all required channels and configurations was not more than 0.5 dB higher than the highest bandwidth; and the reported LTE SAR for the highest bandwidth was less than 1.45 W/kg for all configurations according to FCC KDB 941225 D05v02r04.

This device supports both LTE Band 2 and LTE Band 25. Since the supported frequency span for LTE Band 2 falls completely within the supported frequency span for LTE Band 25, both LTE bands have the same target power, and both LTE bands share the same transmission path, SAR was only assessed for LTE Band 25.

This device supports both LTE Band 5 and LTE Band 26. Since the supported frequency span for LTE Band 5 falls completely within the supported frequency span for LTE Band 26, LTE B5 has lower target than LTE B26, and both LTE bands share the same transmission path, SAR was only assessed for LTE Band 26.



1.7 Guidance Applied

- IEEE 1528-2013
- FCC KDB Publication 941225 D01v03r01, D05v02r04, D06v02r01 (2G/3G/4G and Hotspot)
- FCC KDB Publication 248227 D01v02r02 (SAR Considerations for 802.11 Devices)
- FCC KDB Publication 447498 D01v06 (General SAR Guidance)
- FCC KDB Publication 865664 D01v01r04, D02v01r02 (SAR Measurements up to 6 GHz)
- October 2013 TCB Workshop Notes (GPRS Testing Considerations)

1.8 Device Serial Numbers

Several samples with identical hardware were used to support SAR testing. The manufacturer has confirmed that the device(s) tested have the same physical, mechanical and thermal characteristics and are within operational tolerances expected for production units.



	Head Serial Number	Body-Worn Serial Number	Hotspot Serial Number
CDMA/EVDO BC10 (§90S)	06715	06715	06715
CDMA/EVDO BC0 (§22H)	06715	06715	06715
PCS CDMA/EVDO	06715	06715	06715
GSM/GPRS/EDGE 850	06715	06715	06715
GSM/GPRS/EDGE 1900	06715	06715	06715
UMTS 850	06731	06723	06723
UMTS 1750	06715	06715	06715
UMTS 1900	06715	06715	06715
LTE Band 12	06731	06731	06731
LTE Band 26 (Cell)	06731	06731	06731
LTE Band 4 (AWS)	06731	06731	06731
LTE Band 25 (PCS)	06731	06731	06731
LTE Band 41	06731	06731	06731
2.4 GHz WLAN	06723	06723	06723

FCC ID: ZNFLS450	 PCTEST PROFESSIONAL LABORATORY, INC.	SAR EVALUATION REPORT		Reviewed by: Quality Manager
Document S/N: 0Y1604060711-R1.ZNF	Test Dates: 04/05/16 - 04/11/16	DUT Type: Portable Handset	Page 7 of 59	

2

LTE INFORMATION

LTE Information					
FCC ID	ZNFLS450				
Form Factor	Portable Handset				
Frequency Range of each LTE transmission band	LTE Band 12 (699.7 - 715.3 MHz)				
	LTE Band 26 (Cell) (814.7 - 848.3 MHz)				
	LTE Band 5 (Cell) (824.7 - 848.3 MHz)				
	LTE Band 4 (AWS) (1710.7 - 1754.3 MHz)				
	LTE Band 25 (PCS) (1850.7 - 1914.3 MHz)				
	LTE Band 2 (PCS) (1850.7 - 1909.3 MHz)				
	LTE Band 41 (2498.5 - 2687.5 MHz)				
Channel Bandwidths	LTE Band 12: 1.4 MHz, 3 MHz, 5 MHz, 10 MHz				
	LTE Band 26 (Cell): 1.4 MHz, 3 MHz, 5 MHz, 10 MHz, 15 MHz				
	LTE Band 5 (Cell): 1.4 MHz, 3 MHz, 5 MHz, 10 MHz				
	LTE Band 4 (AWS): 1.4 MHz, 3 MHz, 5 MHz, 10 MHz, 15 MHz, 20 MHz				
	LTE Band 25 (PCS): 1.4 MHz, 3 MHz, 5 MHz, 10 MHz, 15 MHz, 20 MHz				
	LTE Band 2 (PCS): 1.4 MHz, 3 MHz, 5 MHz, 10 MHz, 15 MHz, 20 MHz				
Channel Numbers and Frequencies (MHz)	LTE Band 41: 5 MHz, 10 MHz, 15 MHz, 20 MHz				
	Low	Low-Mid	Mid	Mid-High	High
LTE Band 12: 1.4 MHz	699.7 (23017)		707.5 (23095)		715.3 (23173)
LTE Band 12: 3 MHz	700.5 (23025)		707.5 (23095)		714.5 (23165)
LTE Band 12: 5 MHz	701.5 (23035)		707.5 (23095)		713.5 (23155)
LTE Band 12: 10 MHz	704 (23060)		707.5 (23095)		711 (23130)
LTE Band 26 (Cell): 1.4 MHz	814.7 (26697)		831.5 (26865)		848.3 (27033)
LTE Band 26 (Cell): 3 MHz	815.5 (26705)		831.5 (26865)		847.5 (27025)
LTE Band 26 (Cell): 5 MHz	816.5 (26715)		831.5 (26865)		846.5 (27015)
LTE Band 26 (Cell): 10 MHz	819 (26740)		831.5 (26865)		844 (26990)
LTE Band 26 (Cell): 15 MHz	821.5 (26765)		836.5 (26915)		841.5 (26965)
LTE Band 5 (Cell): 1.4 MHz	824.7 (20407)		836.5 (20525)		848.3 (20643)
LTE Band 5 (Cell): 3 MHz	825.5 (20415)		836.5 (20525)		847.5 (20635)
LTE Band 5 (Cell): 5 MHz	826.5 (20425)		836.5 (20525)		846.5 (20625)
LTE Band 5 (Cell): 10 MHz	829 (20450)		836.5 (20525)		844 (20600)
LTE Band 4 (AWS): 1.4 MHz	1710.7 (19957)		1732.5 (20175)		1754.3 (20393)
LTE Band 4 (AWS): 3 MHz	1711.5 (19965)		1732.5 (20175)		1753.5 (20385)
LTE Band 4 (AWS): 5 MHz	1712.5 (19975)		1732.5 (20175)		1752.5 (20375)
LTE Band 4 (AWS): 10 MHz	1715 (20000)		1732.5 (20175)		1750 (20350)
LTE Band 4 (AWS): 15 MHz	1717.5 (20025)		1732.5 (20175)		1747.5 (20325)
LTE Band 4 (AWS): 20 MHz	1720 (20050)		1732.5 (20175)		1745 (20300)
LTE Band 25 (PCS): 1.4 MHz	1850.7 (26047)		1882.5 (26365)		1914.3 (26683)
LTE Band 25 (PCS): 3 MHz	1851.5 (26055)		1882.5 (26365)		1913.5 (26675)
LTE Band 25 (PCS): 5 MHz	1852.5 (26065)		1882.5 (26365)		1912.5 (26665)
LTE Band 25 (PCS): 10 MHz	1855 (26090)		1882.5 (26365)		1910 (26640)
LTE Band 25 (PCS): 15 MHz	1857.5 (26115)		1882.5 (26365)		1907.5 (26615)
LTE Band 25 (PCS): 20 MHz	1860 (26140)		1882.5 (26365)		1905 (26590)
LTE Band 2 (PCS): 1.4 MHz	1850.7 (18607)		1880 (18900)		1909.3 (19193)
LTE Band 2 (PCS): 3 MHz	1851.5 (18615)		1880 (18900)		1908.5 (19185)
LTE Band 2 (PCS): 5 MHz	1852.5 (18625)		1880 (18900)		1907.5 (19175)
LTE Band 2 (PCS): 10 MHz	1855 (18650)		1880 (18900)		1905 (19150)
LTE Band 2 (PCS): 15 MHz	1857.5 (18675)		1880 (18900)		1902.5 (19125)
LTE Band 2 (PCS): 20 MHz	1860 (18700)		1880 (18900)		1900 (19100)
LTE Band 41: 5 MHz	2506 (39750)	2549.5 (40185)	2593 (40620)	2636.5 (41055)	2680 (41490)
LTE Band 41: 10 MHz	2506 (39750)	2549.5 (40185)	2593 (40620)	2636.5 (41055)	2680 (41490)
LTE Band 41: 15 MHz	2506 (39750)	2549.5 (40185)	2593 (40620)	2636.5 (41055)	2680 (41490)
LTE Band 41: 20 MHz	2506 (39750)	2549.5 (40185)	2593 (40620)	2636.5 (41055)	2680 (41490)
UE Category	4				
Modulations Supported in UL	QPSK, 16QAM				
LTE MPR Permanently implemented per 3GPP TS 36.101 section 6.2.3-6.2.5? (manufacturer attestation to be provided)	YES				
A-MPR (Additional MPR) disabled for SAR Testing?	YES				

FCC ID: ZNFLS450		SAR EVALUATION REPORT			Reviewed by: Quality Manager
Document S/N: OY1604060711-R1.ZNF	Test Dates: 04/05/16 - 04/11/16	DUT Type: Portable Handset		Page 8 of 59	

3 INTRODUCTION

The FCC and Innovation, Science, and Economic Development Canada have adopted the guidelines for evaluating the environmental effects of radio frequency (RF) radiation in ET Docket 93-62 on Aug. 6, 1996 and Health Canada Safety Code 6 to protect the public and workers from the potential hazards of RF emissions due to FCC-regulated portable devices. [1]

The safety limits used for the environmental evaluation measurements are based on the criteria published by the American National Standards Institute (ANSI) for localized specific absorption rate (SAR) in IEEE/ANSI C95.1-1992 Standard for Safety Levels with Respect to Human Exposure to Radio Frequency Electromagnetic Fields, 3 kHz to 300 GHz [3] and Health Canada RF Exposure Guidelines Safety Code 6 [22]. The measurement procedure described in IEEE/ANSI C95.3-2002 Recommended Practice for the Measurement of Potentially Hazardous Electromagnetic Fields - RF and Microwave [4] is used for guidance in measuring the Specific Absorption Rate (SAR) due to the RF radiation exposure from the Equipment Under Test (EUT). These criteria for SAR evaluation are similar to those recommended by the International Committee for Non-Ionizing Radiation Protection (ICNIRP) in Biological Effects and Exposure Criteria for Radiofrequency Electromagnetic Fields,” Report No. Vol 74. SAR is a measure of the rate of energy absorption due to exposure to an RF transmitting source. SAR values have been related to threshold levels for potential biological hazards.

3.1 SAR Definition

Specific Absorption Rate is defined as the time derivative (rate) of the incremental energy (dU) absorbed by (dissipated in) an incremental mass (dm) contained in a volume element (dV) of a given density (ρ). It is also defined as the rate of RF energy absorption per unit mass at a point in an absorbing body (see Equation 3-1).

Equation 3-1
SAR Mathematical Equation

$$SAR = \frac{d}{dt} \left(\frac{dU}{dm} \right) = \frac{d}{dt} \left(\frac{dU}{\rho dv} \right)$$



SAR is expressed in units of Watts per Kilogram (W/kg).

$$SAR = \frac{\sigma \cdot E^2}{\rho}$$

where:

- σ = conductivity of the tissue-simulating material (S/m)
- ρ = mass density of the tissue-simulating material (kg/m³)
- E = Total RMS electric field strength (V/m)

NOTE: The primary factors that control rate of energy absorption were found to be the wavelength of the incident field in relation to the dimensions and geometry of the irradiated organism, the orientation of the organism in relation to the polarity of field vectors, the presence of reflecting surfaces, and whether conductive contact is made by the organism with a ground plane.[6]

FCC ID: ZNFLS450	 PCTEST ENGINEERING LABORATORY, INC.	SAR EVALUATION REPORT		Reviewed by: Quality Manager
Document S/N: OY1604060711-R1.ZNF	Test Dates: 04/05/16 - 04/11/16	DUT Type: Portable Handset	Page 9 of 59	

4 DOSIMETRIC ASSESSMENT

4.1 Measurement Procedure

The evaluation was performed using the following procedure compliant to FCC KDB Publication 865664 D01v01r04 and IEEE 1528-2013:

1. The SAR distribution at the exposed side of the head or body was measured at a distance no greater than 5.0 mm from the inner surface of the shell. The area covered the entire dimension of the device-head and body interface and the horizontal grid resolution was determined per FCC KDB Publication 865664 D01v01r04 (See Table 4-1) and IEEE 1528-2013.
2. The point SAR measurement was taken at the maximum SAR region determined from Step 1 to enable the monitoring of SAR fluctuations/drifts during the 1g/10g cube evaluation. SAR at this fixed point was measured and used as a reference value.
3. Based on the area scan data, the peak of the region with maximum SAR was determined by spline interpolation. Around this point, a volume was assessed according to the measurement resolution and volume size requirements of FCC KDB Publication 865664 D01v01r04 (See Table 4-1) and IEEE 1528-2013. On the basis of this data set, the spatial peak SAR value was evaluated with the following procedure (see references or the DASY manual online for more details):
 - a. SAR values at the inner surface of the phantom are extrapolated from the measured values along the line away from the surface with spacing no greater than that in Table 4-1. The extrapolation was based on a least-squares algorithm. A polynomial of the fourth order was calculated through the points in the z-axis (normal to the phantom shell).
 - b. After the maximum interpolated values were calculated between the points in the cube, the SAR was averaged over the spatial volume (1g or 10g) using a 3D-Spline interpolation algorithm. The 3D-spline is composed of three one-dimensional splines with the “Not a knot” condition (in x, y, and z directions). The volume was then integrated with the trapezoidal algorithm. One thousand points (10 x 10 x 10) were obtained through interpolation, in order to calculate the averaged SAR.
 - c. All neighboring volumes were evaluated until no neighboring volume with a higher average value was found.
4. The SAR reference value, at the same location as step 2, was re-measured after the zoom scan was complete to calculate the SAR drift. If the drift deviated by more than 5%, the SAR test and drift measurements were repeated.

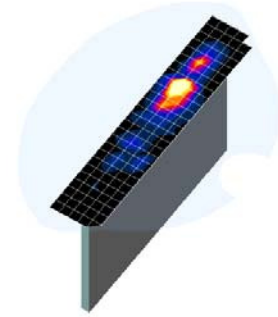



Figure 4-1
Sample SAR Area Scan

Table 4-1
Area and Zoom Scan Resolutions per FCC KDB Publication 865664 D01v01r04*

Frequency	Maximum Area Scan Resolution (mm) ($\Delta x_{area}, \Delta y_{area}$)	Maximum Zoom Scan Resolution (mm) ($\Delta x_{zoom}, \Delta y_{zoom}$)	Maximum Zoom Scan Spatial Resolution (mm)			Minimum Zoom Scan Volume (mm) (x,y,z)
			Uniform Grid	Graded Grid		
			$\Delta z_{zoom}(n)$	$\Delta z_{zoom}(1)^*$	$\Delta z_{zoom}(n>1)^*$	
≤ 2 GHz	≤ 15	≤ 8	≤ 5	≤ 4	≤ 1.5* $\Delta z_{zoom}(n-1)$	≥ 30
2-3 GHz	≤ 12	≤ 5	≤ 5	≤ 4	≤ 1.5* $\Delta z_{zoom}(n-1)$	≥ 30
3-4 GHz	≤ 12	≤ 5	≤ 4	≤ 3	≤ 1.5* $\Delta z_{zoom}(n-1)$	≥ 28
4-5 GHz	≤ 10	≤ 4	≤ 3	≤ 2.5	≤ 1.5* $\Delta z_{zoom}(n-1)$	≥ 25
5-6 GHz	≤ 10	≤ 4	≤ 2	≤ 2	≤ 1.5* $\Delta z_{zoom}(n-1)$	≥ 22

*Also compliant to IEEE 1528-2013 Table 6

FCC ID: ZNFLS450		SAR EVALUATION REPORT		Reviewed by: Quality Manager
Document S/N: OY1604060711-R1.ZNF	Test Dates: 04/05/16 - 04/11/16	DUT Type: Portable Handset		Page 10 of 59

5 DEFINITION OF REFERENCE POINTS

5.1 EAR REFERENCE POINT

Figure 5-2 shows the front, back and side views of the SAM Twin Phantom. The “M” is the reference point for the center of the mouth, “LE” is the left ear reference (ERP), and “RE” is the right ERP. The ERP is 15mm posterior to the entrance to ear canal (EEC) along the B-M line (Back-Mouth), as shown in Figure 5-1. The passing through the two ear canals and M is defined as the Reference Plane. The N-F (Neck-Front), also called the Reference Pivoting Line, is not perpendicular to reference plane (see Figure 5-1). Line B-M is perpendicular to the N-F line. Both and B-M lines are marked on the external phantom shell to facilitate handset positioning [5].

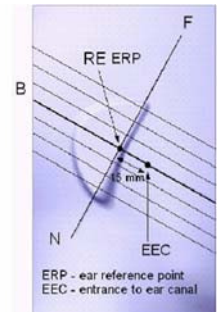

point
point
the
plane
line
the
N-F

Figure 5-1
Close-Up Side view
of ERP

5.2 HANDSET REFERENCE POINTS

Two imaginary lines on the handset were established: the vertical centerline and the horizontal line. The test device was placed in a normal operating position with the acoustic output located along the “vertical centerline” on the front of the device aligned to the “ear reference point” (See Figure 5-3). The acoustic output was then located at the same level as the center of the ear reference point. The test device was positioned so that the “vertical centerline” was bisecting the front surface of the handset at its top and bottom edges, positioning the “ear reference point” on the outer surface of the both the left and right head phantoms on the ear reference point.



Figure 5-2
Front, back and side view of SAM Twin Phantom

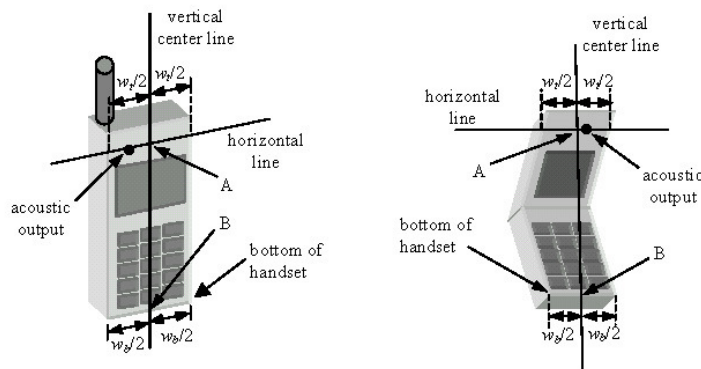



Figure 5-3
Handset Vertical Center & Horizontal Line Reference Points

FCC ID: ZNFLS450	 PCTEST ENGINEERING LABORATORY, INC.	SAR EVALUATION REPORT	 LG	Reviewed by: Quality Manager
Document S/N: OY1604060711-R1.ZNF	Test Dates: 04/05/16 - 04/11/16	DUT Type: Portable Handset		Page 11 of 59

6 TEST CONFIGURATION POSITIONS

6.1 Device Holder

The device holder is made out of low-loss POM material having the following dielectric parameters: relative permittivity $\epsilon = 3$ and loss tangent $\delta = 0.02$.

6.2 Positioning for Cheek

1. The test device was positioned with the device close to the surface of the phantom such that point A is on the (virtual) extension of the line passing through points RE and LE on the phantom (see Figure 6-1), such that the plane defined by the vertical center line and the horizontal line of the phone is approximately parallel to the sagittal plane of the phantom.

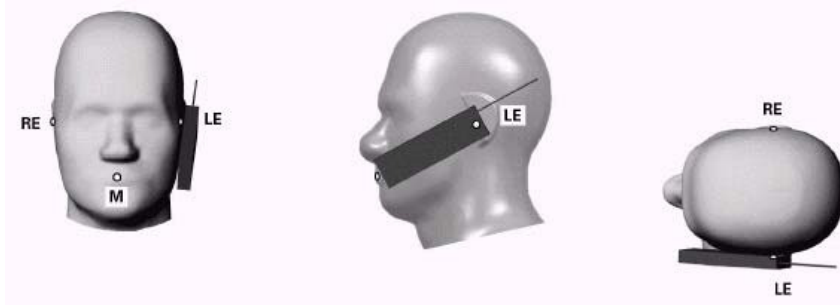



Figure 6-1 Front, Side and Top View of Cheek Position

2. The handset was translated towards the phantom along the line passing through RE & LE until the handset touches the pinna.
3. While maintaining the handset in this plane, the handset was rotated around the LE-RE line until the vertical centerline was in the reference plane.
4. The phone was then rotated around the vertical centerline until the phone (horizontal line) was symmetrical with respect to the line NF.
5. While maintaining the vertical centerline in the reference plane, keeping point A on the line passing through RE and LE, and maintaining the device contact with the ear, the device was rotated about the NF line until any point on the handset made contact with a phantom point below the ear (cheek) (See Figure 6-2).

6.3 Positioning for Ear / 15° Tilt

With the test device aligned in the “Cheek Position”:

1. While maintaining the orientation of the phone, the phone was retracted parallel to the reference plane far enough to enable a rotation of the phone by 15 degrees.
2. The phone was then rotated around the horizontal line by 15 degrees.
3. While maintaining the orientation of the phone, the phone was moved parallel to the reference plane until any part of the handset touched the head. (In this position, point A was located on the line RE-LE). The tilted position is obtained when the contact is on the pinna. If the contact was at any location other than the pinna, the angle of the phone would then be reduced. In this situation, the tilted position was obtained when any part of the phone was in contact of the ear as well as a second part of the phone was in contact with the head (see Figure 6-2).

FCC ID: ZNFLS450	 PCTEST ENGINEERING LABORATORY, INC.	SAR EVALUATION REPORT	 LG	Reviewed by: Quality Manager
Document S/N: OY1604060711-R1.ZNF	Test Dates: 04/05/16 - 04/11/16	DUT Type: Portable Handset		Page 12 of 59

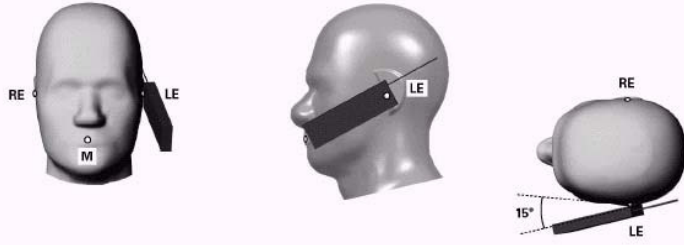

Figure 6-2 Front, Side and Top View of Ear/15° Tilt Position

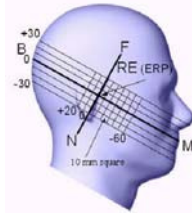

Figure 6-3 Side view w/ relevant markings

6.4 SAR Evaluations near the Mouth/Jaw Regions of the SAM Phantom

Antennas located near the bottom of a phone may require SAR measurements around the mouth and jaw regions of the SAM head phantom. This typically applies to clam-shell style phones that are generally longer in the unfolded normal use positions or to certain older style long rectangular phones. Per IEEE 1528-2013, a rotated SAM phantom is necessary to allow probe access to such regions. Both SAM heads of the TwinSAM-Chin20 are rotated 20 degrees around the NF line. Each head can be removed from the table for emptying and cleaning.

Under these circumstances, the following procedures apply, adopted from the FCC guidance on SAR handsets document FCC KDB Publication 648474 D04v01r03. The SAR required in these regions of SAM should be measured using a flat phantom. The phone should be positioned with a separation distance of 4 mm between the ear reference point (ERP) and the outer surface of the flat phantom shell. While maintaining this distance at the ERP location, the low (bottom) edge of the phone should be lowered from the phantom to establish the same separation distance between the peak SAR location identified by the truncated partial SAR distribution measured with the SAM phantom. The distance from the peak SAR location to the phone is determined by the straight line passing perpendicularly through the phantom surface. When it is not feasible to maintain 4 mm separation at the ERP while also establishing the required separation at the peak SAR location, the top edge of the phone will be allowed to touch the phantom with a separation < 4 mm at the ERP. The phone should not be tilted to the left or right while placed in this inclined position to the flat phantom.

6.5 Body-Worn Accessory Configurations

Body-worn operating configurations are tested with the belt-clips and holsters attached to the device and positioned against a flat phantom in a normal use configuration (see Figure 6-4). Per FCC KDB Publication 648474 D04v01r03, Body-worn accessory exposure is typically related to voice mode operations when handsets are carried in body-worn accessories. The body-worn accessory procedures in FCC KDB Publication 447498 D01v06 should be used to test for body-worn accessory SAR compliance, without a headset connected to it. This enables the test results for such configuration to be compatible with that required for hotspot mode when the body-worn accessory test separation distance is greater than or equal to that required for hotspot mode, when applicable. When the reported SAR for a body-worn accessory, measured without a headset connected to the handset, is > 1.2 W/kg, the highest reported SAR configuration for that wireless mode and frequency band should be repeated for that body-worn accessory with a headset attached to the handset.

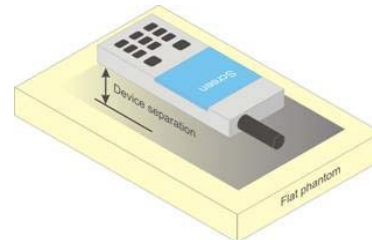



Figure 6-4 Sample Body-Worn Diagram

Accessories for Body-worn operation configurations are divided into two categories: those that do not contain metallic components and those that do contain metallic components. When multiple accessories that do not contain metallic components are supplied with the device, the device is tested with only the accessory that

FCC ID: ZNFLS450	 PCTEST PROFESSIONAL LABORATORY, INC.	SAR EVALUATION REPORT	 LG	Reviewed by: Quality Manager
Document S/N: OY1604060711-R1.ZNF	Test Dates: 04/05/16 - 04/11/16	DUT Type: Portable Handset		Page 13 of 59

dictates the closest spacing to the body. Then multiple accessories that contain metallic components are tested with the device with each accessory. If multiple accessories share an identical metallic component (i.e. the same metallic belt-clip used with different holsters with no other metallic components) only the accessory that dictates the closest spacing to the body is tested.

Body-worn accessories may not always be supplied or available as options for some devices intended to be authorized for body-worn use. In this case, a test configuration with a separation distance between the back of the device and the flat phantom is used. Test position spacing was documented.

Transmitters that are designed to operate in front of a person's face, as in push-to-talk configurations, are tested for SAR compliance with the front of the device positioned to face the flat phantom in head fluid. For devices that are carried next to the body such as a shoulder, waist or chest-worn transmitters, SAR compliance is tested with the accessories, including headsets and microphones, attached to the device and positioned against a flat phantom in a normal use configuration.

6.6 Extremity Exposure Configurations



Devices that are designed or intended for use on extremities or mainly operated in extremity only exposure conditions; i.e., hands, wrists, feet and ankles, may require extremity SAR evaluation. When the device also operates in close proximity to the user's body, SAR compliance for the body is also required. The 1-g body and 10-g extremity SAR Exclusion Thresholds found in KDB Publication 447498 D01v06 should be applied to determine SAR test requirements.

Per KDB Publication 447498 D01v06, Cell phones (handsets) are not normally designed to be used on extremities or operated in extremity only exposure conditions. The maximum output power levels of handsets generally do not require extremity SAR testing to show compliance. Therefore, extremity SAR was not evaluated for this device.

6.7 Wireless Router Configurations

Some battery-operated handsets have the capability to transmit and receive user data through simultaneous transmission of WIFI simultaneously with a separate licensed transmitter. The FCC has provided guidance in FCC KDB Publication 941225 D06v02r01 where SAR test considerations for handsets ($L \times W \geq 9 \text{ cm} \times 5 \text{ cm}$) are based on a composite test separation distance of 10 mm from the front, back and edges of the device containing transmitting antennas within 2.5 cm of their edges, determined from general mixed use conditions for this type of devices. Since the hotspot SAR results may overlap with the body-worn accessory SAR requirements, the more conservative configurations can be considered, thus excluding some body-worn accessory SAR tests.

When the user enables the personal wireless router functions for the handset, actual operations include simultaneous transmission of both the WIFI transmitter and another licensed transmitter. Both transmitters often do not transmit at the same transmitting frequency and thus cannot be evaluated for SAR under actual use conditions due to the limitations of the SAR assessment probes. Therefore, SAR must be evaluated for each frequency transmission and mode separately and spatially summed with the WIFI transmitter according to FCC KDB Publication 447498 D01v06 procedures. The "Portable Hotspot" feature on the handset was NOT activated during SAR assessments, to ensure the SAR measurements were evaluated for a single transmission frequency RF signal at a time.

FCC ID: ZNFLS450	 PCTEST ENGINEERING LABORATORY, INC.	SAR EVALUATION REPORT		Reviewed by: Quality Manager
Document S/N: 0Y1604060711-R1.ZNF	Test Dates: 04/05/16 - 04/11/16	DUT Type: Portable Handset	Page 14 of 59	

7 RF EXPOSURE LIMITS

7.1 Uncontrolled Environment

UNCONTROLLED ENVIRONMENTS are defined as locations where there is the exposure of individuals who have no knowledge or control of their exposure. The general population/uncontrolled exposure limits are applicable to situations in which the general public may be exposed or in which persons who are exposed as a consequence of their employment may not be made fully aware of the potential for exposure or cannot exercise control over their exposure. Members of the general public would come under this category when exposure is not employment-related; for example, in the case of a wireless transmitter that exposes persons in its vicinity.



7.2 Controlled Environment

CONTROLLED ENVIRONMENTS are defined as locations where there is exposure that may be incurred by persons who are aware of the potential for exposure, (i.e. as a result of employment or occupation). In general, occupational/controlled exposure limits are applicable to situations in which persons are exposed as a consequence of their employment, who have been made fully aware of the potential for exposure and can exercise control over their exposure. This exposure category is also applicable when the exposure is of a transient nature due to incidental passage through a location where the exposure levels may be higher than the general population/uncontrolled limits, but the exposed person is fully aware of the potential for exposure and can exercise control over his or her exposure by leaving the area or by some other appropriate means.

**Table 7-1
SAR Human Exposure Specified in ANSI/IEEE C95.1-1992 and Health Canada Safety Code 6**

HUMAN EXPOSURE LIMITS		
	UNCONTROLLED ENVIRONMENT <i>General Population</i> (W/kg) or (mW/g)	CONTROLLED ENVIRONMENT <i>Occupational</i> (W/kg) or (mW/g)
Peak Spatial Average SAR Head	1.6	8.0
Whole Body SAR	0.08	0.4
Peak Spatial Average SAR Hands, Feet, Ankle, Wrists, etc.	4.0	20

1. The Spatial Peak value of the SAR averaged over any 1 gram of tissue (defined as a tissue volume in the shape of a cube) and over the appropriate averaging time.
2. The Spatial Average value of the SAR averaged over the whole body.
3. The Spatial Peak value of the SAR averaged over any 10 grams of tissue (defined as a tissue volume in the shape of a cube) and over the appropriate averaging time.

FCC ID: ZNFLS450	 PCTEST ENGINEERING LABORATORY, INC.	SAR EVALUATION REPORT	 LG	Reviewed by: Quality Manager
Document S/N: 0Y1604060711-R1.ZNF	Test Dates: 04/05/16 - 04/11/16	DUT Type: Portable Handset		Page 15 of 59

8 FCC MEASUREMENT PROCEDURES

Power measurements for licensed transmitters are performed using a base station simulator under digital average power.

8.1 Measured and Reported SAR

Per FCC KDB Publication 447498 D01v06, when SAR is not measured at the maximum power level allowed for production units, the results must be scaled to the maximum tune-up tolerance limit according to the power applied to the individual channels tested to determine compliance. For simultaneous transmission, the measured aggregate SAR must be scaled according to the sum of the differences between the maximum tune-up tolerance and actual power used to test each transmitter. When SAR is measured at or scaled to the maximum tune-up tolerance limit, the results are referred to as *reported* SAR. The highest *reported* SAR results are identified on the grant of equipment authorization according to procedures in KDB 690783 D01v01r03.

8.2 3G SAR Test Reduction Procedure

In FCC KDB Publication 941225 D01v03r01, certain transmission modes within a frequency band and wireless mode evaluated for SAR are defined as primary modes. The equivalent modes considered for SAR test reduction are denoted as secondary modes. When the maximum output power including tune-up tolerance specified for production units in a secondary mode is ≤ 0.25 dB higher than the primary mode or when the highest reported SAR of the primary mode, scaled by the ratio of specified maximum output power and tune-up tolerance of secondary to primary mode, is ≤ 1.2 W/kg, SAR measurements are not required for the secondary mode. These criteria are referred to as the 3G SAR test reduction procedure. When the 3G SAR test reduction procedure is not satisfied, SAR measurements are additionally required for the secondary mode.

8.3 Procedures Used to Establish RF Signal for SAR

The following procedures are according to FCC KDB Publication 941225 D01v03r01 “3G SAR Measurement Procedures.”

The device is placed into a simulated call using a base station simulator in a RF shielded chamber. Establishing connections in this manner ensure a consistent means for testing SAR and are recommended for evaluating SAR [4]. Devices under test are evaluated prior to testing, with a fully charged battery and were configured to operate at maximum output power. In order to verify that the device is tested throughout the SAR test at maximum output power, the SAR measurement system measures a “point SAR” at an arbitrary reference point at the start and end of the 1 gram SAR evaluation, to assess for any power drifts during the evaluation. If the power drift deviates by more than 5%, the SAR test and drift measurements are repeated.



8.4 SAR Measurement Conditions for CDMA2000

The following procedures were performed according to FCC KDB Publication 941225 D01v03r01 “3G SAR Measurement Procedures.”

8.4.1 Output Power Verification

See 3GPP2 C.S0011/TIA-98-E as recommended by FCC KDB Publication 941225 D01v03r01 “3G SAR Measurement Procedures.” Maximum output power is verified on the High, Middle and Low channels according to procedures in section 4.4.5.2 of 3GPP2 C.S0011/TIA-98-E. SO55 tests were measured with power control bits in the “All Up” condition.

1. If the mobile station (MS) supports Reverse TCH RC 1 and Forward TCH RC 1, set up a call using Fundamental Channel Test Mode 1 (RC=1/1) with 9600 bps data rate only.
2. Under RC1, C.S0011 Table 4.4.5.2-1, Table 8-1 parameters were applied.

FCC ID: ZNFLS450	 PCTEST PROFESSIONAL LABORATORY, INC.	SAR EVALUATION REPORT		Reviewed by: Quality Manager
Document S/N: OY1604060711-R1.ZNF	Test Dates: 04/05/16 - 04/11/16	DUT Type: Portable Handset		Page 16 of 59

3. If the MS supports the RC 3 Reverse FCH, RC3 Reverse SCH₀ and demodulation of RC 3,4, or 5, set up a call using Supplemental Channel Test Mode 3 (RC 3/3) with 9600 bps Fundamental Channel and 9600 bps SCH₀ data rate.
4. Under RC3, C.S0011 Table 4.4.5.2-2, Table 8-2 was applied.

Table 8-1
Parameters for Max. Power for RC1

Parameter	Units	Value
I_{or}	dBm/1.23 MHz	-104
$\frac{Pilot E_c}{I_{or}}$	dB	-7
$\frac{Traffic E_c}{I_{or}}$	dB	-7.4

Table 8-2
Parameters for Max. Power for RC3

Parameter	Units	Value
I_{or}	dBm/1.23 MHz	-86
$\frac{Pilot E_c}{I_{or}}$	dB	-7
$\frac{Traffic E_c}{I_{or}}$	dB	-7.4

5. FCHs were configured at full rate for maximum SAR with “All Up” power control bits.

8.4.2 Head SAR Measurements

SAR for next to the ear head exposure is measured in RC3 with the handset configured to transmit at full rate in SO55. The 3G SAR test reduction procedure is applied to RC1 with RC3 as the primary mode; otherwise, SAR is required for the channel with maximum measured output in RC1 using the head exposure configuration that results in the highest reported SAR in RC3.

Head SAR is additionally evaluated using EVDO Rev. A to support compliance for VoIP operations. See Section 8.4.5 for EVDO Rev. A configuration parameters.

8.4.3 Body-worn SAR Measurements

SAR for body-worn exposure configurations is measured in RC3 with the DUT configured to transmit at full rate on FCH with all other code channels disabled using TDSO / SO32. The 3G SAR test reduction procedure is applied to the multiple code channel configuration (FCH+SCH_n), with FCH only as the primary mode. Otherwise, SAR is required for multiple code channel configuration (FCH + SCH_n), with FCH at full rate and SCH₀ enabled at 9600 bps, using the highest reported SAR configuration for FCH only. When multiple code channels are enabled, the transmitter output can shift by more than 0.5 dB and may lead to higher SAR drifts and SCH dropouts.



The 3G SAR test reduction procedure is applied to body-worn accessory SAR in RC1 with RC3 as the primary mode. Otherwise, SAR is required for RC1, with SO55 and full rate, using the highest reported SAR configuration for body-worn accessory exposure in RC3.

8.4.4 Body-worn SAR Measurements for EVDO Devices

For handsets with Ev-Do capabilities, the 3G SAR test reduction procedure is applied to Ev-Do Rev. 0 with 1x RTT RC3 as the primary mode to determine body-worn accessory test requirements. Otherwise, body-worn accessory SAR is required for Rev. 0, at 153.6 kbps, using the highest reported SAR configuration for body-worn accessory exposure in RC3.

The 3G SAR test reduction procedure is applied to Rev. A, with Rev. 0 as the primary mode to determine body-worn accessory SAR test requirements. When SAR is not required for Rev. 0, the 3G SAR test reduction is applied with 1x RTT RC3 as the primary mode.

When SAR is required for EVDO Rev. A, SAR is measured with a Reverse Data Channel payload size of 4096 bits and a Termination Target of 16 slots defined for Subtype 2 Physical Layer configurations, using the highest reported SAR configuration for body-worn accessory exposure in Rev. 0 or 1x RTT RC3, as appropriate.

FCC ID: ZNFLS450	 PCTEST ENGINEERING LABORATORY, INC.	SAR EVALUATION REPORT		Reviewed by: Quality Manager
Document S/N: OY1604060711-R1.ZNF	Test Dates: 04/05/16 - 04/11/16	DUT Type: Portable Handset		Page 17 of 59

8.4.5 Body SAR Measurements for EVDO Hotspot

Hotspot Body SAR is measured using Subtype 0/1 Physical Layer configurations for Rev. 0. The 3G SAR test reduction procedure is applied to Rev. A, Subtype 2 Physical layer configuration, with Rev. 0 as the primary mode; otherwise, SAR is measured for Rev. A using the highest reported SAR configuration for body-worn accessory exposure in Rev. 0. The AT is tested with a Reverse Data Channel rate of 153.6 kbps in Subtype 0/1 Physical Layer configurations; and a Reverse Data Channel payload size of 4096 bits and Termination Target of 16 slots in Subtype 2 Physical Layer configurations.

For Ev-Do data devices that also support 1x RTT voice and/or data operations, the 3G SAR test reduction procedure is applied to 1x RTT RC3 and RC1 with Ev-Do Rev. 0 and Rev. A as the respective primary modes. Otherwise, the 'Body-Worn Accessory SAR' procedures in the '3GPP2 CDMA 2000 1x Handsets' section are applied.

8.4.6 CDMA2000 1x Advanced

This device additionally supports 1x Advanced. Conducted powers are measured using SO75 with RC8 on the uplink and RC11 on the downlink per FCC KDB Publication 941225 D01v03r01. Smart blanking is disabled for all measurements. The EUT is configured with forward power control Mode 000 and reverse power control at 400 bps. Conducted powers are measured on an Agilent 8960 Series 10 Wireless Communications Test Set, Model E5515C using the CDMA2000 1x Advanced application, Option E1962B-410.

The 3G SAR test reduction procedure is applied to the 1x-Advanced transmission mode with 1x RTT RC3 as the primary mode. When SAR measurement is required, the 1x-Advanced power measurement configurations are used. The 1x Advanced SAR procedures are applied separately to head, body-worn accessory and other exposure conditions.

8.5 SAR Measurement Conditions for UMTS

8.5.1 Output Power Verification



Maximum output power is verified on the High, Middle and Low channels according to the general descriptions in section 5.2 of 3GPP TS 34.121, using the appropriate RMC with TPC (transmit power control) set to all "1s" or applying the required inner loop power control procedures to maintain maximum output power while HSUPA is active. Results for all applicable physical channel configurations (DPCCH, DPDCH_n and spreading codes, HS-DPCCH etc) are tabulated in this test report. All configurations that are not supported by the DUT or cannot be measured due to technical or equipment limitations are identified.

8.5.2 Head SAR Measurements

SAR for next to the ear head exposure is measured using a 12.2 kbps RMC with TPC bits configured to all "1s". The 3G SAR test reduction procedure is applied to AMR configurations with 12.2 kbps RMC as the primary mode. Otherwise, SAR is measured for 12.2 kbps AMR in 3.4 kbps SRB (signaling radio bearer) using the highest reported SAR configuration in 12.2 kbps RMC for head exposure.

8.5.3 Body SAR Measurements

SAR for body exposure configurations is measured using the 12.2 kbps RMC with the TPC bits all "1s". The 3G SAR test reduction procedure is applied to other spreading codes and multiple DPDCH_n configurations supported by the handset with 12.2 kbps RMC as the primary mode. Otherwise, SAR is measured using an applicable RMC configuration with the corresponding spreading code or DPDCH_n, for the highest reported SAR configuration in 12.2 kbps RMC.

FCC ID: ZNFLS450		SAR EVALUATION REPORT		Reviewed by: Quality Manager
Document S/N: OY1604060711-R1.ZNF	Test Dates: 04/05/16 - 04/11/16	DUT Type: Portable Handset		Page 18 of 59

8.5.4 SAR Measurements with Rel 5 HSDPA

The 3G SAR test reduction procedure is applied to HSDPA body configurations with 12.2 kbps RMC as the primary mode. Otherwise, Body SAR for HSDPA is measured using an FRC with H-Set 1 in Sub-test 1 and a 12.2 kbps RMC configured in Test Loop Mode 1, for the highest reported SAR configuration in 12.2 kbps RMC without HSDPA. Handsets with both HSDPA and HSUPA are tested according to Release 6 HSPA test procedures.

8.5.5 SAR Measurements with Rel 6 HSUPA

The 3G SAR test reduction procedure is applied to HSPA (HSUPA/HSDPA with RMC) body configurations with 12.2 kbps RMC as the primary mode. Otherwise, Body SAR for HSPA is measured with E-DCH Sub-test 5, using H-Set 1 and QPSK for FRC and a 12.2 kbps RMC configured in Test Loop Mode 1 and power control algorithm 2, according to the highest reported body SAR configuration in 12.2 kbps RMC without HSPA.

When VOIP applies to head exposure, the 3G SAR test reduction procedure is applied with 12.2 kbps RMC as the primary mode; otherwise, the same HSPA configuration used for body SAR measurements are applied to head exposure testing.

8.6 SAR Measurement Conditions for LTE

LTE modes are tested according to FCC KDB 941225 D05v02r04 publication. Establishing connections with base station simulators ensure a consistent means for testing SAR and are recommended for evaluating SAR [4]. The R&S CMW500 or Anritsu MT8820C simulators are used for LTE output power measurements and SAR testing. Closed loop power control was used so the UE transmits with maximum output power during SAR testing. SAR tests were performed with the same number of RB and RB offsets transmitting on all TTI frames (maximum TTI).

8.6.1 Spectrum Plots for RB Configurations

A properly configured base station simulator was used for SAR tests and power measurements. Therefore, spectrum plots for RB configurations were not required to be included in this report.

8.6.2 MPR

MPR is permanently implemented for this device by the manufacturer. The specific manufacturer target MPR is indicated alongside the SAR results. MPR is enabled for this device, according to 3GPP TS36.101 Section 6.2.3 – 6.2.5 under Table 6.2.3-1.



8.6.3 A-MPR

A-MPR (Additional MPR) has been disabled for all SAR tests by setting NS=01 on the base station simulator.

8.6.4 Required RB Size and RB Offsets for SAR Testing

According to FCC KDB 941225 D05v02r04:

- a. Per Section 5.2.1, SAR is required for QPSK 1 RB Allocation for the largest bandwidth
 - i. The required channel and offset combination with the highest maximum output power is required for SAR.
 - ii. When the reported SAR is ≤ 0.8 W/kg, testing of the remaining RB offset configurations and required test channels is not required. Otherwise, SAR is required for the remaining required test channels using the RB offset configuration with highest output power for that channel.

FCC ID: ZNFLS450	 PCTEST PROFESSIONAL LABORATORY, INC.	SAR EVALUATION REPORT		Reviewed by: Quality Manager
Document S/N: OY1604060711-R1.ZNF	Test Dates: 04/05/16 - 04/11/16	DUT Type: Portable Handset		Page 19 of 59

- iii. When the reported SAR for a required test channel is > 1.45 W/kg, SAR is required for all RB offset configurations for that channel.
- b. Per Section 5.2.2, SAR is required for 50% RB allocation using the largest bandwidth following the same procedures outlined in Section 5.2.1.
- c. Per Section 5.2.3, QPSK SAR is not required for the 100% allocation when the highest maximum output power for the 100% allocation is less than the highest maximum output power of the 1 RB and 50% RB allocations and the reported SAR for the 1 RB and 50% RB allocations is < 0.8 W/kg.
- d. Per Section 5.2.4 and 5.3, SAR tests for higher order modulations and lower bandwidths configurations are not required when the conducted power of the required test configurations determined by Sections 5.2.1 through 5.2.3 is less than or equal to ½ dB higher than the equivalent configuration using QPSK modulation and when the QPSK SAR for those configurations is <1.45 W/kg.

8.6.5 TDD

LTE TDD testing is performed using the SAR test guidance provided in FCC KDB 941225 D05v02r04. TDD is tested at the highest duty factor using UL-DL configuration 0 with special subframe configuration 6 and applying the FDD LTE procedures in KDB 941225 D05v02r04. SAR testing was performed using the normal cyclic prefix and then scaling up the measured SAR result to the extended cyclic prefix listed in 3GPP TS 36.211 Section 4. Per FCC KDB Publication 447498 D01v06. when the reported (scaled) for LTE Band 41 SAR measured at the highest output power channel in a given a test configuration was > 0.6 W/kg, testing at the other channels was required for such test configurations.

8.7 SAR Testing with 802.11 Transmitters

The normal network operating configurations of 802.11 transmitters are not suitable for SAR measurements. Unpredictable fluctuations in network traffic and antenna diversity conditions can introduce undesirable variations in SAR results. The SAR for these devices should be measured using chipset based test mode software to ensure the results are consistent and reliable. See KDB Publication 248227 D01v02r02 for more details.



8.7.1 General Device Setup

Chipset based test mode software is hardware dependent and generally varies among manufacturers. The device operating parameters established in test mode for SAR measurements must be identical to those programmed in production units, including output power levels, amplifier gain settings and other RF performance tuning parameters.

A periodic duty factor is required for current generation SAR systems to measure SAR. When 802.11 frame gaps are accounted for in the transmission, a maximum transmission duty factor of 92 - 96% is typically achievable in most test mode configurations. A minimum transmission duty factor of 85% is required to avoid certain hardware and device implementation issues related to wide range SAR scaling. The reported SAR is scaled to 100% transmission duty factor to determine compliance at the maximum tune-up tolerance limit.

8.7.2 Initial Test Position Procedure

For exposure conditions with multiple test positions, such as handset operating next to the ear, devices with hotspot mode or UMPC mini-tablet, procedures for initial test position can be applied. Using the transmission mode determined by the DSSS procedure or initial test configuration, area scans are measured for all positions in an exposure condition. The test position with the highest extrapolated (peak) SAR is used as the initial test position. When reported SAR for the initial test position is ≤ 0.4 W/kg, no additional testing for the remaining test positions is required. Otherwise, SAR is evaluated at the subsequent highest peak SAR positions until the reported SAR result is ≤ 0.8 W/kg or all test positions are measured.

FCC ID: ZNFLS450	 PCTEST PROFESSIONAL LABORATORY, INC.	SAR EVALUATION REPORT			Reviewed by: Quality Manager
Document S/N: OY1604060711-R1.ZNF	Test Dates: 04/05/16 - 04/11/16	DUT Type: Portable Handset		Page 20 of 59	

8.7.3 2.4 GHz SAR Test Requirements

SAR is measured for 2.4 GHz 802.11b DSSS using either the fixed test position or, when applicable, the initial test position procedure. SAR test reduction is determined according to the following:

- 1) When the reported SAR of the highest measured maximum output power channel for the exposure configuration is ≤ 0.8 W/kg, no further SAR testing is required for 802.11b DSSS in that exposure configuration.
- 2) When the reported SAR is > 0.8 W/kg, SAR is required for that position using the next highest measured output power channel. When any reported SAR is > 1.2 W/kg, SAR is required for the third channel; i.e., all channels require testing.

2.4 GHz 802.11 g/n OFDM are additionally evaluated for SAR if the highest reported SAR for 802.11b, adjusted by the ratio of the OFDM to DSSS specified maximum output power, is > 1.2 W/kg. When SAR is required for OFDM modes in 2.4 GHz band, the Initial Test Configuration Procedures should be followed.

8.7.4 OFDM Transmission Mode and SAR Test Channel Selection

For the 2.4 GHz, when the same maximum output power was specified for multiple OFDM transmission mode configurations in a frequency band or aggregated band, SAR is measured using the configuration with the largest channel bandwidth, lowest order modulation and lowest data rate. When the maximum output power of a channel is the same for equivalent OFDM configurations; for example, 802.11g and 802.11n with the same channel bandwidth, modulation and data rate etc., the lower order 802.11 mode i.e., 802.11g then 802.11n, is used for SAR measurement. When the maximum output power are the same for multiple test channels, either according to the default or additional power measurement requirements, SAR is measured using the channel closest to the middle of the frequency band or aggregated band. When there are multiple channels with the same maximum output power, SAR is measured using the higher number channel.



8.7.5 Initial Test Configuration Procedure

For OFDM, in 2.4 Ghz bands, an initial test configuration is determined, according to the transmission mode with the highest maximum output power specified for SAR measurements. When the same maximum output power is specified for multiple OFDM transmission mode configurations in a frequency band, SAR is measured using the configuration(s) with the largest channel bandwidth, lowest order modulation, lowest data rate and lowest order IEEE 802.11 mode. The channel of the transmission mode with the highest average RF output conducted power will be the initial test configuration.

When the reported SAR is ≤ 0.8 W/kg, no additional measurements on other test channels are required. Otherwise, SAR is evaluated using the subsequent highest average RF output channel until the reported SAR result is ≤ 1.2 W/kg or all channels are measured. When there are multiple untested channels having the same subsequent highest average RF output power, the channel with higher frequency from the lowest 802.11 mode is considered for SAR measurements (See Section 8.7.4).

8.7.6 Subsequent Test Configuration Procedures

For OFDM configurations in each frequency band SAR is evaluated for initial test configuration using the fixed test position or the initial test position procedure. When the highest reported SAR (for the initial test configuration), adjusted by the ratio of the specified maximum output power of the subsequent test configuration to initial test configuration, is ≤ 1.2 W/kg, no additional SAR tests for the subsequent test configurations are required.

FCC ID: ZNFLS450	 PCTEST PROFESSIONAL LABORATORY, INC.	SAR EVALUATION REPORT		Reviewed by: Quality Manager
Document S/N: OY1604060711-R1.ZNF	Test Dates: 04/05/16 - 04/11/16	DUT Type: Portable Handset		Page 21 of 59



9.1 CDMA Conducted Powers

Band	Channel	Rule Part	Frequency	SO55 [dBm]	SO55 [dBm]	SO75 [dBm]	TDSO SO32 [dBm]	TDSO SO32 [dBm]	1x EvDO Rev. 0 [dBm]	1x EvDO Rev. A [dBm]
	F-RC		MHz	RC1	RC3	RC11	FCH+SCH	FCH	(RTAP)	(RETAP)
Cellular	564	90S	820.1	24.90	24.89	24.87	24.92	24.90	24.65	24.55
Cellular	1013	22H	824.7	24.51	24.57	24.56	24.65	24.55	24.60	24.60
	384	22H	836.52	24.67	24.57	24.56	24.53	24.61	24.51	24.60
	777	22H	848.31	24.59	24.65	24.56	24.65	24.61	24.58	24.58
PCS	25	24E	1851.25	23.93	23.91	24.09	23.97	23.90	23.92	23.90
	600	24E	1880	23.76	23.95	24.08	23.79	23.92	24.00	23.91
	1175	24E	1908.75	23.68	23.80	23.80	23.75	23.78	23.83	23.78

Note: RC1 is only applicable for IS-95 compatibility. For FCC Rule Part 90S, Per FCC KDB Publication 447498 D01v06 4.1.g), only one channel is required since the device operates within the transmission range of 817.90 – 823.10 MHz.



Figure 9-1
Power Measurement Setup

FCC ID: ZNFLS450	 PCTEST ENGINEERING LABORATORY, INC.	SAR EVALUATION REPORT		Reviewed by: Quality Manager
Document S/N: OY1604060711-R1.ZNF	Test Dates: 04/05/16 - 04/11/16	DUT Type: Portable Handset		Page 22 of 59

9.2 GSM Conducted Powers

Maximum Burst-Averaged Output Power						
		Voice	GPRS/EDGE Data (GMSK)		EDGE Data (8-PSK)	
Band	Channel	GSM [dBm] CS (1 Slot)	GPRS [dBm] 1 Tx Slot	GPRS [dBm] 2 Tx Slot	EDGE [dBm] 1 Tx Slot	EDGE [dBm] 2 Tx Slot
GSM 850	128	32.47	32.41	31.03	27.63	26.57
	190	32.60	32.53	31.12	27.64	26.55
	251	32.59	32.56	30.79	27.58	26.58
GSM 1900	512	29.70	29.90	26.99	26.57	25.63
	661	29.63	29.77	26.94	26.56	25.48
	810	29.86	29.97	27.04	26.63	25.40
Calculated Maximum Frame-Averaged Output Power						
		Voice	GPRS/EDGE Data (GMSK)		EDGE Data (8-PSK)	
Band	Channel	GSM [dBm] CS (1 Slot)	GPRS [dBm] 1 Tx Slot	GPRS [dBm] 2 Tx Slot	EDGE [dBm] 1 Tx Slot	EDGE [dBm] 2 Tx Slot
GSM 850	128	23.44	23.38	25.01	18.60	20.55
	190	23.57	23.50	25.10	18.61	20.53
	251	23.56	23.53	24.77	18.55	20.56
GSM 1900	512	20.67	20.87	20.97	17.54	19.61
	661	20.60	20.74	20.92	17.53	19.46
	810	20.83	20.94	21.02	17.60	19.38
GSM 850	Frame	23.67	23.67	25.18	18.17	20.18
GSM 1900	Avg. Targets:	20.67	20.67	21.18	17.17	19.18

Note:

- Both burst-averaged and calculated frame-averaged powers are included. Frame-averaged power was calculated from the measured burst-averaged power by converting the slot powers into linear units and calculating the energy over 8 timeslots.
- GPRS/EDGE (GMSK) output powers were measured with coding scheme setting of 1 (CS1) on the base station simulator. CS1 was configured to measure GPRS output power measurements and SAR to ensure GMSK modulation in the signal. Our Investigation has shown that CS1 - CS4 settings do not have any impact on the output levels or modulation in the GPRS modes.
- EDGE (8-PSK) output powers were measured with MCS7 on the base station simulator. MCS7 coding scheme was used to measure the output powers for EDGE since investigation has shown that choosing MCS7 coding scheme will ensure 8-PSK modulation. It has been shown that MCS levels that produce 8PSK modulation do not have an impact on output power.

GSM Class: B



GPRS Multislot class: 10 (Max 2 Tx uplink slots)

EDGE Multislot class: 10 (Max 2 Tx uplink slots)

DTM Multislot Class: N/A



Figure 9-2
Power Measurement Setup

FCC ID: ZNFLS450		SAR EVALUATION REPORT		Reviewed by: Quality Manager
Document S/N: OY1604060711-R1.ZNF	Test Dates: 04/05/16 - 04/11/16	DUT Type: Portable Handset		Page 23 of 59



9.3 UMTS Conducted Powers

3GPP Release Version	Mode	3GPP 34.121 Subtest	Cellular Band [dBm]			AWS Band [dBm]			PCS Band [dBm]			3GPP MPR [dB]
			4132	4183	4233	1312	1412	1513	9262	9400	9538	
99	WCDMA	12.2 kbps RMC	23.61	23.56	23.61	22.49	22.59	22.62	23.58	23.56	23.60	-
99		12.2 kbps AMR	23.59	23.58	23.53	22.47	22.20	22.45	23.55	23.58	23.53	-
6	HSDPA	Subtest 1	23.62	23.54	23.52	22.63	22.41	22.62	23.64	23.57	23.54	0
6		Subtest 2	23.54	23.57	23.64	22.66	22.53	22.57	23.52	23.54	23.63	0
6		Subtest 3	23.00	23.11	23.13	22.13	22.12	22.01	23.11	23.08	23.06	0.5
6		Subtest 4	23.10	23.15	23.17	22.11	22.08	22.13	23.13	23.11	23.18	0.5
6	HSUPA	Subtest 1	23.52	23.55	23.40	22.53	22.59	22.52	23.57	23.52	23.49	0
6		Subtest 2	21.40	21.44	21.55	20.61	20.59	20.50	21.44	21.34	21.48	2
6		Subtest 3	22.53	22.54	22.55	21.67	21.55	21.52	22.54	22.54	22.58	1
6		Subtest 4	21.47	21.47	21.42	20.55	20.63	20.59	21.53	21.59	21.53	2
6		Subtest 5	23.63	23.61	23.69	22.68	22.65	22.55	23.64	23.64	23.65	0

This device does not support DC-HSDPA.



Figure 9-3
Power Measurement Setup

FCC ID: ZNFLS450	 SAR EVALUATION REPORT 		Reviewed by: Quality Manager
Document S/N: 0Y1604060711-R1.ZNF	Test Dates: 04/05/16 - 04/11/16	DUT Type: Portable Handset	Page 24 of 59

9.4 LTE Conducted Powers

9.4.1 LTE Band 12



**Table 9-1
LTE Band 12 Conducted Powers - 10 MHz Bandwidth**

LTE Band 12 10 MHz Bandwidth					
Modulation	RB Size	RB Offset	Mid Channel	MPR Allowed per 3GPP [dB]	MPR [dB]
			23095 (707.5 MHz)		
			Conducted Power [dBm]		
QPSK	1	0	24.62	0	0
	1	25	24.71		0
	1	49	24.65		0
	25	0	23.61	0-1	1
	25	12	23.69		1
	25	25	23.61		1
16QAM	50	0	23.60	0-1	1
	1	0	23.61		1
	1	25	23.72		1
	1	49	23.60	0-2	1
	25	0	22.55		2
	25	12	22.63		2
	25	25	22.72		2
	50	0	22.71	2	

Note: LTE Band 12 at 10 MHz bandwidth does not support three non-overlapping channels. Per KDB Publication 941225 D05v02, when a device supports overlapping channel assignment in a channel bandwidth configuration, the middle channel of the group of overlapping channels should be selected for testing.

**Table 9-2
LTE Band 12 Conducted Powers - 5 MHz Bandwidth**

LTE Band 12 5 MHz Bandwidth							
Modulation	RB Size	RB Offset	Low Channel	Mid Channel	High Channel	MPR Allowed per 3GPP [dB]	MPR [dB]
			23035 (701.5 MHz)	23095 (707.5 MHz)	23155 (713.5 MHz)		
			Conducted Power [dBm]	Conducted Power [dBm]	Conducted Power [dBm]		
QPSK	1	0	24.69	24.60	24.76	0	0
	1	12	24.72	24.71	24.73		0
	1	24	24.68	24.70	24.69		0
	12	0	23.65	23.67	23.77	0-1	1
	12	6	23.70	23.65	23.69		1
	12	13	23.54	23.68	23.60		1
	25	0	23.60	23.71	23.59		1
16QAM	1	0	23.70	23.67	23.72	0-1	1
	1	12	23.71	23.68	23.80		1
	1	24	23.71	23.69	23.57		1
	12	0	22.72	22.60	22.60	0-2	2
	12	6	22.64	22.71	22.77		2
	12	13	22.67	22.69	22.68		2
	25	0	22.65	22.64	22.61		2



FCC ID: ZNFLS450		SAR EVALUATION REPORT		Reviewed by: Quality Manager
Document S/N: 0Y1604060711-R1.ZNF	Test Dates: 04/05/16 - 04/11/16	DUT Type: Portable Handset		Page 25 of 59

**Table 9-3
LTE Band 12 Conducted Powers - 3 MHz Bandwidth**

LTE Band 12 3 MHz Bandwidth							
Modulation	RB Size	RB Offset	Low Channel	Mid Channel	High Channel	MPR Allowed per 3GPP [dB]	MPR [dB]
			23025 (700.5 MHz)	23095 (707.5 MHz)	23165 (714.5 MHz)		
Conducted Power [dBm]							
QPSK	1	0	24.56	24.50	24.72	0	0
	1	7	24.57	24.65	24.71		0
	1	14	24.66	24.69	24.63		0
	8	0	23.68	23.58	23.54	0-1	1
	8	4	23.65	23.59	23.59		1
	8	7	23.56	23.60	23.72		1
16QAM	15	0	23.67	23.69	23.70	0-1	1
	1	0	23.56	23.71	23.68		1
	1	7	23.53	23.58	23.60		1
	1	14	23.69	23.57	23.64	0-2	1
	8	0	22.51	22.60	22.65		2
	8	4	22.58	22.70	22.72		2
	8	7	22.52	22.54	22.66		2
15	0	22.60	22.60	22.69	2		

**Table 9-4
LTE Band 12 Conducted Powers -1.4 MHz Bandwidth**

LTE Band 12 1.4 MHz Bandwidth							
Modulation	RB Size	RB Offset	Low Channel	Mid Channel	High Channel	MPR Allowed per 3GPP [dB]	MPR [dB]
			23017 (699.7 MHz)	23095 (707.5 MHz)	23173 (715.3 MHz)		
Conducted Power [dBm]							
QPSK	1	0	24.72	24.76	24.52	0	0
	1	2	24.64	24.62	24.70		0
	1	5	24.63	24.64	24.53		0
	3	0	24.78	24.66	24.66		0
	3	2	24.72	24.51	24.69		0
	3	3	24.70	24.53	24.61		0
16QAM	6	0	23.69	23.64	23.69	0-1	1
	1	0	23.53	23.55	23.58	0-1	1
	1	2	23.51	23.52	23.64		1
	1	5	23.54	23.68	23.57		1
	3	0	23.57	23.65	23.58		1
	3	2	23.59	23.52	23.55		1
	3	3	23.64	23.69	23.66		1
6	0	22.52	22.58	22.71	0-2	2	

FCC ID: ZNFLS450		SAR EVALUATION REPORT		Reviewed by: Quality Manager
Document S/N: 0Y1604060711-R1.ZNF	Test Dates: 04/05/16 - 04/11/16	DUT Type: Portable Handset		Page 26 of 59

9.4.2

LTE Band 26 (Cell)

Table 9-5
LTE Band 26 (Cell) Conducted Powers - 15 MHz Bandwidth

LTE Band 26 (Cell) 15 MHz Bandwidth					
Modulation	RB Size	RB Offset	Mid Channel	MPR Allowed per 3GPP [dB]	MPR [dB]
			26915 (836.5 MHz) Conducted Power [dBm]		
QPSK	1	0	23.87	0	0
	1	36	23.58		0
	1	74	24.00		0
	36	0	22.79	0-1	1
	36	18	22.74		1
	36	37	22.68		1
16QAM	75	0	22.73	0-1	1
	1	0	22.62		1
	1	36	22.40		1
	1	74	22.89	0-2	1
	36	0	21.69		2
	36	18	21.55		2
	36	37	21.62		2
75	0	21.60	2		

Note: LTE Band 26 (Cell) at 15 MHz bandwidth does not support three non-overlapping channels. Per KDB Publication 941225 D05v02, when a device supports overlapping channel assignment in a channel bandwidth configuration, the middle channel of the group of overlapping channels should be selected for testing.

Table 9-6
LTE Band 26 (Cell) Conducted Powers - 10 MHz Bandwidth

LTE Band 26 (Cell) 10 MHz Bandwidth							
Modulation	RB Size	RB Offset	Low Channel	Mid Channel	High Channel	MPR Allowed per 3GPP [dB]	MPR [dB]
			26740 (819.0 MHz)	26865 (831.5 MHz)	26990 (844.0 MHz)		
QPSK	1	0	23.91	23.91	23.91	0	0
	1	25	23.90	23.89	23.90		0
	1	49	23.90	23.90	23.89		0
	25	0	22.91	22.91	22.88	0-1	1
	25	12	22.90	22.89	22.87		1
	25	25	22.89	22.88	22.87		1
16QAM	50	0	22.88	22.91	22.88	0-1	1
	1	0	22.91	22.89	22.87		1
	1	25	22.89	22.88	22.86		1
	1	49	22.90	22.91	22.87	0-2	1
	25	0	21.90	21.90	21.91		2
	25	12	21.89	21.89	21.90		2
25	25	21.88	21.88	21.88	2		
50	0	21.90	21.89	21.89	2		



FCC ID: ZNFLS450		SAR EVALUATION REPORT		Reviewed by: Quality Manager
Document S/N: OY1604060711-R1.ZNF	Test Dates: 04/05/16 - 04/11/16	DUT Type: Portable Handset		Page 27 of 59

Table 9-7
LTE Band 26 (Cell) Conducted Powers - 5 MHz Bandwidth



LTE Band 26 (Cell) 5 MHz Bandwidth							
Modulation	RB Size	RB Offset	Low Channel	Mid Channel	High Channel	MPR Allowed per 3GPP [dB]	MPR [dB]
			26715 (816.5 MHz)	26865 (831.5 MHz)	27015 (846.5 MHz)		
Conducted Power [dBm]							
QPSK	1	0	23.90	23.90	23.90	0	0
	1	12	23.89	23.91	23.89		0
	1	24	23.91	23.89	23.88		0
	12	0	22.90	22.90	22.91	0-1	1
	12	6	22.89	22.88	22.90		1
	12	13	22.90	22.89	22.89		1
16QAM	25	0	22.89	22.90	22.91	0-1	1
	1	0	22.90	22.89	22.90		1
	1	12	22.91	22.91	22.88		1
	1	24	22.88	22.92	22.89	0-2	1
	12	0	21.89	21.89	21.90		2
	12	6	21.90	21.88	21.89		2
	12	13	21.91	21.91	21.91	2	
	25	0	21.89	21.89	21.89	2	

Table 9-8
LTE Band 26 (Cell) Conducted Powers - 3 MHz Bandwidth

LTE Band 26 (Cell) 3 MHz Bandwidth							
Modulation	RB Size	RB Offset	Low Channel	Mid Channel	High Channel	MPR Allowed per 3GPP [dB]	MPR [dB]
			26705 (815.5 MHz)	26865 (831.5 MHz)	27025 (847.5 MHz)		
Conducted Power [dBm]							
QPSK	1	0	23.90	23.90	23.90	0	0
	1	7	23.89	23.91	23.88		0
	1	14	23.90	23.89	23.89		0
	8	0	22.89	22.90	22.90	0-1	1
	8	4	22.89	22.89	22.91		1
	8	7	22.90	22.92	22.90		1
16QAM	15	0	22.88	22.89	22.92	0-1	1
	1	0	22.91	22.91	22.89		1
	1	7	22.90	22.90	22.91		1
	1	14	22.89	22.88	22.90	0-2	1
	8	0	21.90	21.90	21.90		2
	8	4	21.89	21.89	21.91		2
	8	7	21.90	21.90	21.89	2	
	15	0	21.92	21.88	21.90	2	

Table 9-9
LTE Band 26 (Cell) Conducted Powers -1.4 MHz Bandwidth

LTE Band 26 (Cell) 1.4 MHz Bandwidth							
Modulation	RB Size	RB Offset	Low Channel	Mid Channel	High Channel	MPR Allowed per 3GPP [dB]	MPR [dB]
			26697 (814.7 MHz)	26865 (831.5 MHz)	27033 (848.3 MHz)		
Conducted Power [dBm]							
QPSK	1	0	23.90	23.91	23.90	0	0
	1	2	23.89	23.90	23.89		0
	1	5	23.89	23.89	23.88		0
	3	0	23.90	23.90	23.90		0
	3	2	23.88	23.88	23.89		0
	3	3	23.89	23.90	23.90		0
16QAM	6	0	22.90	22.90	22.90	0-1	1
	1	0	22.89	22.89	22.88		1
	1	2	22.88	22.88	22.89		1
	1	5	22.90	22.90	22.88	0-1	1
	3	0	22.89	22.89	22.90		1
	3	2	22.91	22.90	22.89		1
	3	3	22.88	22.90	22.90	0-2	1
	6	0	21.90	21.89	21.89		2

FCC ID: ZNFLS450	 PCTEST TECHNICAL LABORATORY, INC.	SAR EVALUATION REPORT		Reviewed by: Quality Manager
Document S/N: OY1604060711-R1.ZNF	Test Dates: 04/05/16 - 04/11/16	DUT Type: Portable Handset		Page 28 of 59

9.4.3

LTE Band 4 (AWS)

Table 9-10
LTE Band 4 (AWS) Conducted Powers - 20 MHz Bandwidth

LTE Band 4 (AWS) 20 MHz Bandwidth					
Modulation	RB Size	RB Offset	Mid Channel	MPR Allowed per 3GPP [dB]	MPR [dB]
			20175 (1732.5 MHz) Conducted Power [dBm]		
QPSK	1	0	23.00	0	0
	1	50	23.01		0
	1	99	22.91		0
	50	0	21.98	0-1	1
	50	25	21.99		1
	50	50	21.97		1
16QAM	100	0	21.96	0-1	1
	1	0	22.01		1
	1	50	21.99		1
	1	99	22.01	0-2	1
	50	0	20.89		2
	50	25	20.98		2
	50	50	21.08	2	
	100	0	21.09	2	

Note: LTE Band 4 (AWS) at 20 MHz bandwidth does not support three non-overlapping channels. Per KDB Publication 941225 D05v02, when a device supports overlapping channel assignment in a channel bandwidth configuration, the middle channel of the group of overlapping channels should be selected for testing.

Table 9-11
LTE Band 4 (AWS) Conducted Powers - 15 MHz Bandwidth

LTE Band 4 (AWS) 15 MHz Bandwidth							
Modulation	RB Size	RB Offset	Low Channel	Mid Channel	High Channel	MPR Allowed per 3GPP [dB]	MPR [dB]
			20025 (1717.5 MHz)	20175 (1732.5 MHz)	20325 (1747.5 MHz)		
Conducted Power [dBm]							
QPSK	1	0	23.01	22.85	22.80	0	0
	1	36	23.09	22.81	22.99		0
	1	74	22.91	22.99	23.01		0
	36	0	22.09	21.99	21.79	0-1	1
	36	18	21.98	22.01	21.78		1
	36	37	22.09	21.98	21.79		1
16QAM	75	0	21.81	22.09	21.77	0-1	1
	1	0	21.92	22.01	21.79		1
	1	36	21.99	22.09	21.91		1
	1	74	22.01	22.01	21.81	0-2	1
	36	0	20.80	20.80	20.79		2
	36	18	20.98	20.79	20.99		2
	36	37	20.99	20.78	20.87	2	
	75	0	21.03	20.80	20.78	2	



FCC ID: ZNFLS450		SAR EVALUATION REPORT		Reviewed by: Quality Manager
Document S/N: 0Y1604060711-R1.ZNF	Test Dates: 04/05/16 - 04/11/16	DUT Type: Portable Handset		Page 29 of 59

Table 9-12
LTE Band 4 (AWS) Conducted Powers - 10 MHz Bandwidth

LTE Band 4 (AWS) 10 MHz Bandwidth							
Modulation	RB Size	RB Offset	Low Channel	Mid Channel	High Channel	MPR Allowed per 3GPP [dB]	MPR [dB]
			20000 (1715.0 MHz)	20175 (1732.5 MHz)	20350 (1750.0 MHz)		
Conducted Power [dBm]							
QPSK	1	0	22.98	23.00	22.90	0	0
	1	25	22.99	22.98	22.99		0
	1	49	23.01	22.99	23.00		0
	25	0	21.98	21.98	21.98	0-1	1
	25	12	21.99	21.99	21.99		1
	25	25	21.97	22.00	22.08		1
16QAM	50	0	21.99	22.08	22.07	0-1	1
	1	0	21.97	21.99	22.09		1
	1	25	21.99	22.00	22.01		1
	1	49	21.98	21.98	21.98	0-2	1
	25	0	20.98	20.99	20.99		2
	25	12	20.99	20.98	21.07		2
	25	25	20.98	20.99	20.99		2
	50	0	20.97	20.97	20.98		2

Table 9-13
LTE Band 4 (AWS) Conducted Powers - 5 MHz Bandwidth

LTE Band 4 (AWS) 5 MHz Bandwidth							
Modulation	RB Size	RB Offset	Low Channel	Mid Channel	High Channel	MPR Allowed per 3GPP [dB]	MPR [dB]
			19975 (1712.5 MHz)	20175 (1732.5 MHz)	20375 (1752.5 MHz)		
Conducted Power [dBm]							
QPSK	1	0	23.00	22.98	23.00	0	0
	1	12	22.99	22.91	23.00		0
	1	24	22.97	22.97	22.91		0
	12	0	22.01	21.91	21.91	0-1	1
	12	6	21.98	22.06	22.08		1
	12	13	21.94	22.01	21.99		1
16QAM	25	0	21.99	22.07	22.01	0-1	1
	1	0	21.97	21.98	22.07		1
	1	12	21.97	21.97	22.07		1
	1	24	21.99	22.01	21.99	0-2	1
	12	0	20.95	21.08	20.98		2
	12	6	20.99	21.07	20.99		2
	12	13	20.99	20.99	21.01		2
	25	0	20.98	20.98	21.00		2

Table 9-14
LTE Band 4 (AWS) Conducted Powers - 3 MHz Bandwidth

LTE Band 4 (AWS) 3 MHz Bandwidth							
Modulation	RB Size	RB Offset	Low Channel	Mid Channel	High Channel	MPR Allowed per 3GPP [dB]	MPR [dB]
			19965 (1711.5 MHz)	20175 (1732.5 MHz)	20385 (1753.5 MHz)		
Conducted Power [dBm]							
QPSK	1	0	23.01	22.90	23.00	0	0
	1	7	23.02	23.01	23.09		0
	1	14	23.20	22.97	22.91		0
	8	0	22.08	22.08	22.09	0-1	1
	8	4	21.91	21.97	22.01		1
	8	7	21.90	21.99	21.90		1
16QAM	15	0	22.01	22.08	22.01	0-1	1
	1	0	21.97	22.07	21.99		1
	1	7	21.99	22.00	22.00		1
	1	14	21.97	22.01	22.08	0-2	1
	8	0	21.00	21.00	20.99		2
	8	4	20.97	20.91	20.99		2
	8	7	20.99	21.07	21.08		2
	15	0	20.98	21.08	20.97		2



FCC ID: ZNFLS450		SAR EVALUATION REPORT		Reviewed by: Quality Manager
Document S/N: OY1604060711-R1.ZNF	Test Dates: 04/05/16 - 04/11/16	DUT Type: Portable Handset		Page 30 of 59

Table 9-15
LTE Band 4 (AWS) Conducted Powers -1.4 MHz Bandwidth

LTE Band 4 (AWS) 1.4 MHz Bandwidth							
Modulation	RB Size	RB Offset	Low Channel	Mid Channel	High Channel	MPR Allowed per 3GPP [dB]	MPR [dB]
			19957 (1710.7 MHz)	20175 (1732.5 MHz)	20393 (1754.3 MHz)		
Conducted Power [dBm]							
QPSK	1	0	23.00	23.08	22.90	0	0
	1	2	22.98	22.99	22.99		0
	1	5	22.99	23.00	23.01		0
	3	0	22.91	23.01	23.07		0
	3	2	22.98	23.08	22.99		0
	3	3	22.99	22.99	23.00		0
16QAM	6	0	22.00	22.01	22.00	0-1	1
	1	0	22.08	22.00	22.01	0-1	1
	1	2	21.99	22.07	22.07		1
	1	5	22.01	21.99	22.08		1
	3	0	22.00	21.91	22.05		1
	3	2	22.08	22.08	22.01		1
3	3	21.90	21.98	22.01	1		
	6	0	21.07	20.99	20.98	0-2	2

9.4.4 LTE Band 25 (PCS)

Table 9-16
LTE Band 25 (PCS) Conducted Powers - 20 MHz Bandwidth

LTE Band 25 (PCS) 20 MHz Bandwidth							
Modulation	RB Size	RB Offset	Low Channel	Mid Channel	High Channel	MPR Allowed per 3GPP [dB]	MPR [dB]
			26140 (1860.0 MHz)	26365 (1882.5 MHz)	26590 (1905.0 MHz)		
Conducted Power [dBm]							
QPSK	1	0	23.09	23.61	23.61	0	0
	1	50	23.15	23.62	23.58		0
	1	99	23.10	23.61	23.59		0
	50	0	22.22	22.60	22.61		1
	50	25	22.20	22.62	22.58		1
	50	50	22.15	22.60	22.59		1
16QAM	100	0	22.16	22.58	22.60	0-1	1
	1	0	22.31	22.55	22.59	0-2	1
	1	50	22.61	22.58	22.61		1
	1	99	22.34	22.59	22.58		1
	50	0	21.19	21.57	21.60		2
	50	25	21.08	21.58	21.61		2
50	50	21.11	21.58	21.63	2		
	100	0	21.03	21.56	21.62	2	

Table 9-17
LTE Band 25 (PCS) Conducted Powers - 15 MHz Bandwidth

LTE Band 25 (PCS) 15 MHz Bandwidth							
Modulation	RB Size	RB Offset	Low Channel	Mid Channel	High Channel	MPR Allowed per 3GPP [dB]	MPR [dB]
			26115 (1857.5 MHz)	26365 (1882.5 MHz)	26615 (1907.5 MHz)		
Conducted Power [dBm]							
QPSK	1	0	23.60	23.59	23.55	0	0
	1	36	23.61	23.61	23.59		0
	1	74	23.59	23.59	23.57		0
	36	0	22.61	22.59	22.59		1
	36	18	22.60	22.57	22.61		1
	36	37	22.61	22.59	22.59		1
16QAM	75	0	22.58	22.61	22.61	0-1	1
	1	0	22.59	22.55	22.59	0-2	1
	1	36	22.61	22.59	22.56		1
	1	74	22.58	22.61	22.60		1
	36	0	21.57	21.59	21.59		2
	36	18	21.59	21.58	21.61		2
36	37	21.61	21.61	21.60	2		
	75	0	21.60	21.60	21.60	2	



FCC ID: ZNFLS450		SAR EVALUATION REPORT		Reviewed by: Quality Manager
Document S/N: OY1604060711-R1.ZNF	Test Dates: 04/05/16 - 04/11/16	DUT Type: Portable Handset		Page 31 of 59

Table 9-18
LTE Band 25 (PCS) Conducted Powers - 10 MHz Bandwidth



LTE Band 25 (PCS) 10 MHz Bandwidth							
Modulation	RB Size	RB Offset	Low Channel	Mid Channel	High Channel	MPR Allowed per 3GPP [dB]	MPR [dB]
			26090 (1855.0 MHz)	26365 (1882.5 MHz)	26640 (1910.0 MHz)		
			Conducted Power [dBm]				
QPSK	1	0	23.60	23.58	23.59	0	0
	1	25	23.57	23.59	23.61		0
	1	49	23.59	23.58	23.59		0
	25	0	22.59	22.61	22.60	0-1	1
	25	12	22.61	22.60	22.61		1
	25	25	22.59	22.59	22.59		1
16QAM	50	0	22.60	22.60	22.60	0-1	1
	1	0	22.58	22.59	22.61		1
	1	25	22.59	22.61	22.59		1
	1	49	22.60	22.59	22.61	0-2	1
	25	0	21.58	21.59	21.59		2
	25	12	21.58	21.60	21.58		2
	25	25	21.59	21.59	21.58	0-2	2
	50	0	21.55	21.61	21.57		2

Table 9-19
LTE Band 25 (PCS) Conducted Powers - 5 MHz Bandwidth

LTE Band 25 (PCS) 5 MHz Bandwidth							
Modulation	RB Size	RB Offset	Low Channel	Mid Channel	High Channel	MPR Allowed per 3GPP [dB]	MPR [dB]
			26065 (1852.5 MHz)	26365 (1882.5 MHz)	26665 (1912.5 MHz)		
			Conducted Power [dBm]				
QPSK	1	0	23.57	23.59	23.60	0	0
	1	12	23.60	23.58	23.58		0
	1	24	23.58	23.59	23.59		0
	12	0	22.59	22.60	22.59	0-1	1
	12	6	22.60	22.61	22.60		1
	12	13	22.61	22.58	22.61		1
16QAM	25	0	22.60	22.59	22.60	0-1	1
	1	0	22.58	22.60	22.59		1
	1	12	22.60	22.58	22.61		1
	1	24	22.61	22.60	22.59	0-2	1
	12	0	21.60	21.59	21.58		2
	12	6	21.58	21.60	21.59		2
	12	13	21.59	21.58	21.58	0-2	2
	25	0	21.60	21.60	21.59		2

Table 9-20
LTE Band 25 (PCS) Conducted Powers - 3 MHz Bandwidth

LTE Band 25 (PCS) 3 MHz Bandwidth							
Modulation	RB Size	RB Offset	Low Channel	Mid Channel	High Channel	MPR Allowed per 3GPP [dB]	MPR [dB]
			26055 (1851.5 MHz)	26365 (1882.5 MHz)	26675 (1913.5 MHz)		
			Conducted Power [dBm]				
QPSK	1	0	23.61	23.58	23.58	0	0
	1	7	23.62	23.61	23.59		0
	1	14	23.59	23.60	23.60		0
	8	0	22.59	22.59	22.58	0-1	1
	8	4	22.59	22.61	22.59		1
	8	7	22.58	22.60	22.58		1
16QAM	15	0	22.59	22.60	22.57	0-1	1
	1	0	22.57	22.58	22.61		1
	1	7	22.59	22.57	22.60		1
	1	14	22.61	22.60	22.59	0-2	1
	8	0	21.59	21.58	21.59		2
	8	4	21.59	21.61	21.60		2
	8	7	21.58	21.60	21.61	0-2	2
	15	0	21.55	21.59	21.59		2

FCC ID: ZNFLS450	 PCTEST PROFESSIONAL LABORATORY, INC.	SAR EVALUATION REPORT		Reviewed by: Quality Manager
Document S/N: OY1604060711-R1.ZNF	Test Dates: 04/05/16 - 04/11/16	DUT Type: Portable Handset		Page 32 of 59

**Table 9-21
LTE Band 25 (PCS) Conducted Powers -1.4 MHz Bandwidth**

LTE Band 25 (PCS) 1.4 MHz Bandwidth							
Modulation	RB Size	RB Offset	Low Channel	Mid Channel	High Channel	MPR Allowed per 3GPP [dB]	MPR [dB]
			26047 (1850.7 MHz)	26365 (1882.5 MHz)	26683 (1914.3 MHz)		
Conducted Power [dBm]							
QPSK	1	0	23.61	23.60	23.60	0	0
	1	2	23.59	23.61	23.61		0
	1	5	23.59	23.60	23.58		0
	3	0	23.61	23.59	23.60		0
	3	2	23.60	23.60	23.61		0
	3	3	23.61	23.59	23.60		0
16QAM	6	0	22.58	22.59	22.59	0-1	1
	1	0	22.59	22.60	22.58	0-1	1
	1	2	22.61	22.58	22.59		1
	1	5	22.59	22.60	22.60		1
	3	0	22.60	22.59	22.61		1
	3	2	22.61	22.57	22.60		1
3	3	22.58	22.59	22.59	1		
	6	0	21.59	21.58	21.58	0-2	2

9.4.5 LTE Band 41

**Table 9-22
LTE Band 41 Conducted Powers - 20 MHz Bandwidth**

LTE Band 41 20 MHz Bandwidth										
Modulation	RB Size	RB Offset	Low Channel	Low-Mid Channel	Mid Channel	Mid-High Channel	High Channel	MPR Allowed per 3GPP [dB]	MPR [dB]	
			39750 (2506.0 MHz)	40185 (2549.5 MHz)	40620 (2593.0 MHz)	41055 (2636.5 MHz)	41490 (2680.0 MHz)			
Conducted Power [dBm]										
QPSK	1	0	23.38	23.38	23.40	23.40	23.42	0	0	
	1	50	23.37	23.39	23.39	23.38	23.41		0	
	1	99	23.38	23.40	23.41	23.40	23.41		0	
	QPSK	50	0	22.39	22.38	22.38	22.41	22.37	0-1	1
		50	25	22.38	22.39	22.39	22.38	22.39		1
		50	50	22.40	22.40	22.38	22.38	22.40		1
100		0	22.40	22.37	22.37	22.39	22.38	1		
16QAM	1	0	22.39	22.39	22.38	22.41	22.40	0-1	1	
	1	50	22.40	22.41	22.39	22.39	22.41		1	
	1	99	22.39	22.39	22.40	22.38	22.39		1	
	16QAM	50	0	21.38	21.39	21.37	21.37	21.37	0-2	2
		50	25	21.40	21.40	21.38	21.39	21.39		2
		50	50	21.39	21.41	21.39	21.38	21.41		2
	100	0	21.40	21.39	21.38	21.37	21.39	2		

**Table 9-23
LTE Band 41 Conducted Powers - 15 MHz Bandwidth**

LTE Band 41 15 MHz Bandwidth										
Modulation	RB Size	RB Offset	Low Channel	Low-Mid Channel	Mid Channel	Mid-High Channel	High Channel	MPR Allowed per 3GPP [dB]	MPR [dB]	
			39750 (2506.0 MHz)	40185 (2549.5 MHz)	40620 (2593.0 MHz)	41055 (2636.5 MHz)	41490 (2680.0 MHz)			
Conducted Power [dBm]										
QPSK	1	0	23.41	23.40	23.40	23.38	23.40	0	0	
	1	36	23.40	23.39	23.41	23.39	23.40		0	
	1	74	23.38	23.38	23.42	23.40	23.40		0	
	QPSK	36	0	22.39	22.41	22.40	22.40	22.38	0-1	1
		36	18	22.38	22.40	22.39	22.40	22.39		1
		36	37	22.36	22.37	22.38	22.39	22.40		1
75		0	22.39	22.40	22.39	22.36	22.37	1		
16QAM	1	0	22.39	22.37	22.39	22.35	22.39	0-1	1	
	1	36	22.37	22.38	22.39	22.37	22.40		1	
	1	74	22.39	22.39	22.39	22.38	22.38		1	
	16QAM	36	0	21.40	21.40	21.40	21.38	21.35	0-2	2
		36	18	21.41	21.41	21.39	21.39	21.36		2
		36	37	21.41	21.44	21.35	21.40	21.37		2
	75	0	21.41	21.42	21.38	21.41	21.38	2		





FCC ID: ZNFLS450		SAR EVALUATION REPORT		Reviewed by: Quality Manager
Document S/N: OY1604060711-R1.ZNF	Test Dates: 04/05/16 - 04/11/16	DUT Type: Portable Handset		Page 33 of 59

Table 9-24
LTE Band 41 Conducted Powers - 10 MHz Bandwidth

LTE Band 41 10 MHz Bandwidth										
Modulation	RB Size	RB Offset	Low Channel	Low-Mid Channel	Mid Channel	Mid-High Channel	High Channel	MPR Allowed per 3GPP [dB]	MPR [dB]	
			39750 (2506.0 MHz)	40185 (2549.5 MHz)	40620 (2593.0 MHz)	41055 (2636.5 MHz)	41490 (2680.0 MHz)			
Conducted Power [dBm]										
QPSK	1	0	23.41	23.40	23.41	23.41	23.41	0	0	
	1	25	23.40	23.41	23.38	23.40	23.41		0	
	1	49	23.41	23.40	23.40	23.38	23.40		0	
	QPSK	25	0	22.38	22.40	22.38	22.39	22.41	0-1	1
		25	12	22.41	22.39	22.39	22.40	22.40		1
		25	25	22.40	22.40	22.41	22.38	22.40		1
50		0	22.39	22.38	22.39	22.39	22.41	1		
16QAM	1	0	22.41	22.40	22.40	22.41	22.40	0-1	1	
	1	25	22.38	22.38	22.38	22.38	22.42		1	
	1	49	22.39	22.41	22.39	22.39	22.40		1	
	16QAM	25	0	21.40	21.40	21.40	21.40	21.39	0-2	2
		25	12	21.39	21.39	21.38	21.41	21.38		2
		25	25	21.38	21.38	21.40	21.39	21.39		2
	50	0	21.39	21.37	21.39	21.39	21.40		2	

Table 9-25
LTE Band 41 Conducted Powers - 5 MHz Bandwidth

LTE Band 41 5 MHz Bandwidth										
Modulation	RB Size	RB Offset	Low Channel	Low-Mid Channel	Mid Channel	Mid-High Channel	High Channel	MPR Allowed per 3GPP [dB]	MPR [dB]	
			39750 (2506.0 MHz)	40185 (2549.5 MHz)	40620 (2593.0 MHz)	41055 (2636.5 MHz)	41490 (2680.0 MHz)			
Conducted Power [dBm]										
QPSK	1	0	23.40	23.44	23.44	23.42	23.41	0	0	
	1	12	23.41	23.43	23.38	23.41	23.42		0	
	1	24	23.39	23.44	23.39	23.42	23.41		0	
	QPSK	12	0	22.38	22.41	22.41	22.41	22.43	0-1	1
		12	6	22.40	22.40	22.40	22.40	22.39		1
		12	13	22.38	22.40	22.39	22.40	22.41		1
25		0	22.37	22.41	22.41	22.38	22.42	1		
16QAM	1	0	22.41	22.40	22.39	22.39	22.39	0-1	1	
	1	12	22.38	22.40	22.38	22.40	22.38		1	
	1	24	22.41	22.41	22.37	22.38	22.41		1	
	16QAM	12	0	21.40	21.40	21.40	21.39	21.37	0-2	2
		12	6	21.38	21.38	21.45	21.40	21.39		2
		12	13	21.39	21.39	21.49	21.37	21.38		2
	25	0	21.40	21.38	21.46	21.40	21.41		2	

FCC ID: ZNFLS450		SAR EVALUATION REPORT		Reviewed by: Quality Manager
Document S/N: OY1604060711-R1.ZNF	Test Dates: 04/05/16 - 04/11/16	DUT Type: Portable Handset		Page 34 of 59

9.5 WLAN Conducted Powers

Table 9-26
IEEE 802.11 Average RF Power

Freq [MHz]	Channel	2.4GHz Conducted Power [dBm]		
		IEEE Transmission Mode		
		802.11b	802.11g	802.11n
2412	1	15.37	13.03	13.11
2437	6	15.99	13.47	13.58
2462	11	15.74	13.31	13.26

Justification for test configurations for WLAN per KDB Publication 248227 D01v02r02:

- Power measurements were performed for the transmission mode configuration with the highest maximum output power specified for production units.
- For transmission modes with the same maximum output power specification, powers were measured for the largest channel bandwidth, lowest order modulation and lowest data rate.
- For transmission modes with identical maximum specified output power, channel bandwidth, modulation and data rates, power measurements were required for all identical configurations.
- For each transmission mode configuration, powers were measured for the highest and lowest channels; and at the mid-band channel(s) when there were at least 3 channels supported. For configurations with multiple mid-band channels, due to an even number of channels, both channels were measured.
- The bolded data rate and channel above were tested for SAR.

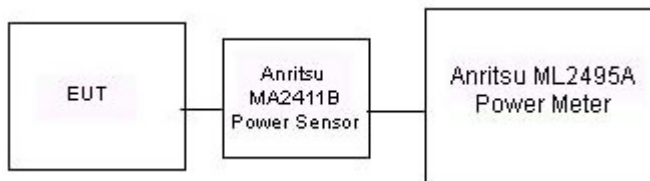



Figure 9-4
Power Measurement Setup for Bandwidths < 50 MHz

FCC ID: ZNFLS450	 PCTEST ENGINEERING LABORATORY, INC.	SAR EVALUATION REPORT		Reviewed by: Quality Manager
Document S/N: 0Y1604060711-R1.ZNF	Test Dates: 04/05/16 - 04/11/16	DUT Type: Portable Handset	Page 35 of 59	



10 SYSTEM VERIFICATION

10.1 Tissue Verification

**Table 10-1
Measured Tissue Properties**

Calibrated for Tests Performed on:	Tissue Type	Tissue Temp During Calibration (°C)	Measured Frequency (MHz)	Measured Conductivity, σ (S/m)	Measured Dielectric Constant, ϵ	TARGET Conductivity, σ (S/m)	TARGET Dielectric Constant, ϵ	% dev σ	% dev ϵ
4/6/2016	750H	22.8	700	0.856	43.381	0.889	42.201	-3.71%	2.80%
			710	0.866	43.243	0.890	42.149	-2.70%	2.60%
			740	0.894	42.820	0.893	41.994	0.11%	1.97%
			755	0.908	42.637	0.894	41.916	1.57%	1.72%
4/7/2016	835H	22.5	820	0.900	42.563	0.899	41.578	0.11%	2.37%
			835	0.914	42.395	0.900	41.500	1.56%	2.16%
			850	0.928	42.197	0.916	41.500	1.31%	1.68%
4/8/2016	835H	22.0	820	0.882	40.205	0.899	41.578	-1.89%	-3.30%
			835	0.896	40.044	0.900	41.500	-0.44%	-3.51%
			850	0.908	39.886	0.916	41.500	-0.87%	-3.89%
4/7/2016	1750H	23.2	1710	1.299	39.626	1.348	40.142	-3.64%	-1.29%
			1750	1.332	39.398	1.371	40.079	-2.84%	-1.70%
			1790	1.376	39.240	1.394	40.016	-1.29%	-1.94%
4/7/2016	1900H	22.8	1850	1.376	39.594	1.400	40.000	-1.71%	-1.02%
			1880	1.409	39.472	1.400	40.000	0.64%	-1.32%
			1910	1.440	39.334	1.400	40.000	2.86%	-1.66%
4/11/2016	1900H	22.0	1850	1.410	40.447	1.400	40.000	0.71%	1.12%
			1880	1.440	40.303	1.400	40.000	2.86%	0.76%
			1910	1.465	40.143	1.400	40.000	4.64%	0.36%
4/9/2016	2450H	23.3	2400	1.821	37.995	1.756	39.289	3.70%	-3.29%
			2450	1.875	37.827	1.800	39.200	4.17%	-3.50%
			2500	1.933	37.583	1.855	39.136	4.20%	-3.97%
4/11/2016	2450H	24.0	2600	2.022	39.029	1.964	39.009	2.95%	0.05%
			2650	2.089	38.821	2.018	38.945	3.52%	-0.32%
			2700	2.146	38.632	2.073	38.882	3.52%	-0.64%
4/6/2016	750B	23.3	700	0.918	54.322	0.959	55.726	-4.28%	-2.52%
			710	0.928	54.139	0.960	55.687	-3.33%	-2.78%
			740	0.952	53.847	0.963	55.570	-1.14%	-3.10%
			755	0.966	53.791	0.964	55.512	0.21%	-3.10%
4/7/2016	835B	22.5	820	0.964	53.214	0.969	55.258	-0.52%	-3.70%
			835	0.979	53.058	0.970	55.200	0.93%	-3.88%
			850	0.994	52.892	0.988	55.154	0.61%	-4.10%
4/10/2016	835B	20.5	820	0.958	53.153	0.969	55.258	-1.14%	-3.81%
			835	0.973	52.954	0.970	55.200	0.31%	-4.07%
			850	0.986	52.806	0.988	55.154	-0.20%	-4.26%
4/6/2016	1750B	22.6	1710	1.442	55.563	1.463	53.537	-1.44%	3.78%
			1750	1.485	55.414	1.488	53.432	-0.20%	3.71%
			1790	1.536	55.297	1.514	53.326	1.45%	3.70%
4/11/2016	1750B	22.3	1710	1.438	51.356	1.463	53.537	-1.71%	-4.07%
			1750	1.477	51.191	1.488	53.432	-0.74%	-4.19%
			1790	1.522	51.049	1.514	53.326	0.53%	-4.27%
4/5/2016	1900B	21.6	1850	1.471	51.591	1.520	53.300	-3.22%	-3.21%
			1880	1.504	51.500	1.520	53.300	-1.05%	-3.38%
			1910	1.536	51.390	1.520	53.300	1.05%	-3.58%
4/9/2016	2450B	23.3	2400	1.964	51.955	1.902	52.767	3.26%	-1.54%
			2450	2.020	51.824	1.950	52.700	3.59%	-1.66%
			2500	2.086	51.580	2.021	52.636	3.22%	-2.01%
4/11/2016	2450B	23.3	2600	2.164	50.348	2.163	52.509	0.05%	-4.12%
			2650	2.234	50.143	2.234	52.445	0.00%	-4.39%
			2700	2.305	49.961	2.305	52.382	0.00%	-4.62%

The above measured tissue parameters were used in the DASY software. The DASY software was used to perform interpolation to determine the dielectric parameters at the SAR test device frequencies (per KDB Publication 865664 D01v01r04 and IEEE 1528-2013 6.6.1.2). The tissue parameters listed in the SAR test plots may slightly differ from the table above due to significant digit rounding in the software.

FCC ID: ZNFLS450		SAR EVALUATION REPORT			Reviewed by: Quality Manager
Document S/N: OY1604060711-R1.ZNF	Test Dates: 04/05/16 - 04/11/16	DUT Type: Portable Handset			Page 36 of 59

10.2 Test System Verification

Prior to SAR assessment, the system is verified to $\pm 10\%$ of the SAR measurement on the reference dipole at the time of calibration by the calibration facility. Full system validation status and result summary can be found in Appendix E.

**Table 10-2
System Verification Results**

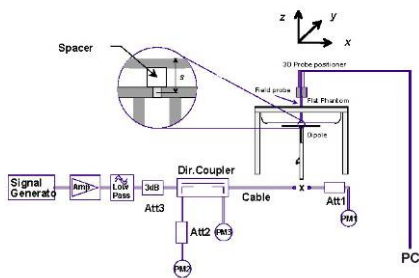

System Verification TARGET & MEASURED												
SAR System #	Tissue Frequency (MHz)	Tissue Type	Date:	Amb. Temp (°C)	Liquid Temp (°C)	Input Power (W)	Dipole SN	Probe SN	Measured SAR _{1g} (W/kg)	1 W Target SAR _{1g} (W/kg)	1 W Normalized SAR _{1g} (W/kg)	Deviation _{1g} (%)
I	750	HEAD	04/06/2016	23.4	23.0	0.200	1054	3333	1.620	8.220	8.100	-1.46%
K	835	HEAD	04/07/2016	24.0	22.5	0.200	4d133	3022	1.960	9.130	9.800	7.34%
C	835	HEAD	04/08/2016	23.5	22.0	0.200	4d132	3288	1.930	9.470	9.650	1.90%
K	1750	HEAD	04/07/2016	23.0	23.2	0.100	1051	3022	3.570	36.200	35.700	-1.38%
D	1900	HEAD	04/07/2016	23.5	22.5	0.100	5d149	3213	4.080	40.700	40.800	0.25%
A	1900	HEAD	04/11/2016	23.5	22.0	0.100	5d148	3332	3.840	39.900	38.400	-3.76%
J	2450	HEAD	04/09/2016	20.1	21.9	0.100	882	3318	5.050	50.500	50.500	0.00%
H	2600	HEAD	04/11/2016	22.7	23.0	0.100	1071	3319	5.540	55.900	55.400	-0.89%
A	750	BODY	04/06/2016	23.3	23.3	0.200	1003	3332	1.770	8.660	8.850	2.19%
J	835	BODY	04/07/2016	23.2	22.7	0.200	4d133	3318	1.950	9.250	9.750	5.41%
J	835	BODY	04/10/2016	20.1	20.5	0.200	4d133	3318	2.000	9.250	10.000	8.11%
E	1750	BODY	04/06/2016	23.0	22.6	0.100	1051	3351	3.650	37.100	36.500	-1.62%
E	1750	BODY	04/11/2016	23.0	22.3	0.100	1008	3351	3.670	38.000	36.700	-3.42%
G	1900	BODY	04/05/2016	23.1	22.2	0.100	5d148	3334	4.090	39.700	40.900	3.02%
G	2450	BODY	04/09/2016	22.6	22.3	0.100	882	3334	5.220	49.400	52.200	5.67%
K	2600	BODY	04/11/2016	24.0	23.4	0.100	1071	3022	5.720	54.900	57.200	4.19%



**Figure 10-1
System Verification Setup Diagram**



**Figure 10-2
System Verification Setup Photo**

FCC ID: ZNFLS450	 PCTEST ENGINEERING LABORATORY, INC.	SAR EVALUATION REPORT	 LG	Reviewed by: Quality Manager
Document S/N: OY1604060711-R1.ZNF	Test Dates: 04/05/16 - 04/11/16	DUT Type: Portable Handset		Page 37 of 59

11 SAR DATA SUMMARY



11.1 Standalone Head SAR Data

**Table 11-1
CDMA BC10 (§90S) Head SAR**

MEASUREMENT RESULTS														
FREQUENCY		Mode/Band	Service	Maximum Allowed Power [dBm]	Conducted Power [dBm]	Power Drift [dB]	Side	Test Position	Device Serial Number	Duty Cycle	SAR (1g)	Scaling Factor	Reported SAR (1g)	Plot #
MHz	Ch.										(W/kg)		(W/kg)	
820.10	564	CDMA BC10 (§90S)	RC3 / SO55	25.0	24.89	-0.02	Right	Cheek	06715	1:1	0.469	1.026	0.481	A1
820.10	564	CDMA BC10 (§90S)	RC3 / SO55	25.0	24.89	0.16	Right	Tilt	06715	1:1	0.275	1.026	0.282	
820.10	564	CDMA BC10 (§90S)	RC3 / SO55	25.0	24.89	0.04	Left	Cheek	06715	1:1	0.440	1.026	0.451	
820.10	564	CDMA BC10 (§90S)	RC3 / SO55	25.0	24.89	0.13	Left	Tilt	06715	1:1	0.264	1.026	0.271	
820.10	564	CDMA BC10 (§90S)	EVDO Rev. A	25.0	24.55	-0.04	Right	Cheek	06715	1:1	0.453	1.109	0.502	
820.10	564	CDMA BC10 (§90S)	EVDO Rev. A	25.0	24.55	0.19	Right	Tilt	06715	1:1	0.275	1.109	0.305	
820.10	564	CDMA BC10 (§90S)	EVDO Rev. A	25.0	24.55	0.16	Left	Cheek	06715	1:1	0.434	1.109	0.481	
820.10	564	CDMA BC10 (§90S)	EVDO Rev. A	25.0	24.55	0.19	Left	Tilt	06715	1:1	0.281	1.109	0.312	
ANSI / IEEE C95.1 1992 - SAFETY LIMIT Spatial Peak Uncontrolled Exposure/General Population							Head 1.6 W/kg (mW/g) averaged over 1 gram							

**Table 11-2
CDMA BC0 (§22H) Head SAR**

MEASUREMENT RESULTS														
FREQUENCY		Mode/Band	Service	Maximum Allowed Power [dBm]	Conducted Power [dBm]	Power Drift [dB]	Side	Test Position	Device Serial Number	Duty Cycle	SAR (1g)	Scaling Factor	Reported SAR (1g)	Plot #
MHz	Ch.										(W/kg)		(W/kg)	
836.52	384	CDMA BC0 (§22H)	RC3 / SO55	24.7	24.57	-0.02	Right	Cheek	06715	1:1	0.561	1.030	0.578	
836.52	384	CDMA BC0 (§22H)	RC3 / SO55	24.7	24.57	0.05	Right	Tilt	06715	1:1	0.280	1.030	0.288	
836.52	384	CDMA BC0 (§22H)	RC3 / SO55	24.7	24.57	-0.02	Left	Cheek	06715	1:1	0.492	1.030	0.507	
836.52	384	CDMA BC0 (§22H)	RC3 / SO55	24.7	24.57	0.12	Left	Tilt	06715	1:1	0.282	1.030	0.290	
836.52	384	CDMA BC0 (§22H)	EVDO Rev. A	24.7	24.60	0.00	Right	Cheek	06715	1:1	0.584	1.023	0.597	A2
836.52	384	CDMA BC0 (§22H)	EVDO Rev. A	24.7	24.60	0.02	Right	Tilt	06715	1:1	0.289	1.023	0.296	
836.52	384	CDMA BC0 (§22H)	EVDO Rev. A	24.7	24.60	-0.11	Left	Cheek	06715	1:1	0.518	1.023	0.530	
836.52	384	CDMA BC0 (§22H)	EVDO Rev. A	24.7	24.60	0.13	Left	Tilt	06715	1:1	0.297	1.023	0.304	
ANSI / IEEE C95.1 1992 - SAFETY LIMIT Spatial Peak Uncontrolled Exposure/General Population							Head 1.6 W/kg (mW/g) averaged over 1 gram							



FCC ID: ZNFLS450		SAR EVALUATION REPORT		Reviewed by: Quality Manager
Document S/N: OY1604060711-R1.ZNF	Test Dates: 04/05/16 - 04/11/16	DUT Type: Portable Handset		Page 38 of 59

**Table 11-3
PCS CDMA Head SAR**

MEASUREMENT RESULTS														
FREQUENCY		Mode/Band	Service	Maximum Allowed Power [dBm]	Conducted Power [dBm]	Power Drift [dB]	Side	Test Position	Device Serial Number	Duty Cycle	SAR (1g)	Scaling Factor	Reported SAR (1g)	Plot #
MHz	Ch.										(W/kg)		(W/kg)	
1880.00	600	PCS CDMA	RC3 / SO55	24.4	23.95	-0.12	Right	Cheek	06715	1:1	0.342	1.109	0.379	
1880.00	600	PCS CDMA	RC3 / SO55	24.4	23.95	0.13	Right	Tilt	06715	1:1	0.237	1.109	0.263	
1880.00	600	PCS CDMA	RC3 / SO55	24.4	23.95	-0.02	Left	Cheek	06715	1:1	0.611	1.109	0.678	
1880.00	600	PCS CDMA	RC3 / SO55	24.4	23.95	0.00	Left	Tilt	06715	1:1	0.203	1.109	0.225	
1880.00	600	PCS CDMA	EVDO Rev. A	24.4	23.91	0.15	Right	Cheek	06715	1:1	0.356	1.119	0.398	
1880.00	600	PCS CDMA	EVDO Rev. A	24.4	23.91	-0.19	Right	Tilt	06715	1:1	0.242	1.119	0.271	
1880.00	600	PCS CDMA	EVDO Rev. A	24.4	23.91	-0.06	Left	Cheek	06715	1:1	0.652	1.119	0.730	A3
1880.00	600	PCS CDMA	EVDO Rev. A	24.4	23.91	-0.12	Left	Tilt	06715	1:1	0.202	1.119	0.226	
ANSI / IEEE C95.1 1992 - SAFETY LIMIT Spatial Peak Uncontrolled Exposure/General Population							Head 1.6 W/kg (mW/g) averaged over 1 gram							

**Table 11-4
GSM 850 Head SAR**

MEASUREMENT RESULTS															
FREQUENCY		Mode/Band	Service	Maximum Allowed Power [dBm]	Conducted Power [dBm]	Power Drift [dB]	Side	Test Position	Device Serial Number	# of Time Slots	Duty Cycle	SAR (1g)	Scaling Factor	Reported SAR (1g)	Plot #
MHz	Ch.											(W/kg)		(W/kg)	
836.60	190	GSM 850	GSM	33.2	32.60	-0.09	Right	Cheek	06715	1	1:8.3	0.442	1.148	0.507	
836.60	190	GSM 850	GSM	33.2	32.60	0.01	Right	Tilt	06715	1	1:8.3	0.221	1.148	0.254	
836.60	190	GSM 850	GSM	33.2	32.60	0.01	Left	Cheek	06715	1	1:8.3	0.390	1.148	0.448	
836.60	190	GSM 850	GSM	33.2	32.60	0.14	Left	Tilt	06715	1	1:8.3	0.222	1.148	0.255	
836.60	190	GSM 850	GPRS	31.7	31.12	0.10	Right	Cheek	06715	2	1:4.15	0.575	1.143	0.657	A4
836.60	190	GSM 850	GPRS	31.7	31.12	0.18	Right	Tilt	06715	2	1:4.15	0.286	1.143	0.327	
836.60	190	GSM 850	GPRS	31.7	31.12	0.00	Left	Cheek	06715	2	1:4.15	0.493	1.143	0.563	
836.60	190	GSM 850	GPRS	31.7	31.12	0.20	Left	Tilt	06715	2	1:4.15	0.294	1.143	0.336	
ANSI / IEEE C95.1 1992 - SAFETY LIMIT Spatial Peak Uncontrolled Exposure/General Population							Head 1.6 W/kg (mW/g) averaged over 1 gram								

FCC ID: ZNFLS450		SAR EVALUATION REPORT		Reviewed by: Quality Manager
Document S/N: OY1604060711-R1.ZNF	Test Dates: 04/05/16 - 04/11/16	DUT Type: Portable Handset		Page 39 of 59

**Table 11-5
GSM 1900 Head SAR**



MEASUREMENT RESULTS															
FREQUENCY		Mode/Band	Service	Maximum Allowed Power [dBm]	Conducted Power [dBm]	Power Drift [dB]	Side	Test Position	Device Serial Number	# of Time Slots	Duty Cycle	SAR (1g)	Scaling Factor	Reported SAR (1g)	Plot #
MHz	Ch.											(W/kg)		(W/kg)	
1880.00	661	GSM 1900	GSM	30.2	29.63	-0.12	Right	Cheek	06715	1	1:8.3	0.176	1.140	0.201	
1880.00	661	GSM 1900	GSM	30.2	29.63	0.06	Right	Tilt	06715	1	1:8.3	0.108	1.140	0.123	
1880.00	661	GSM 1900	GSM	30.2	29.63	-0.07	Left	Cheek	06715	1	1:8.3	0.309	1.140	0.352	A5
1880.00	661	GSM 1900	GSM	30.2	29.63	0.10	Left	Tilt	06715	1	1:8.3	0.097	1.140	0.111	
1880.00	661	GSM 1900	GPRS	27.7	26.94	-0.16	Right	Cheek	06715	2	1:4.15	0.157	1.191	0.187	
1880.00	661	GSM 1900	GPRS	27.7	26.94	-0.02	Right	Tilt	06715	2	1:4.15	0.109	1.191	0.130	
1880.00	661	GSM 1900	GPRS	27.7	26.94	-0.08	Left	Cheek	06715	2	1:4.15	0.259	1.191	0.308	
1880.00	661	GSM 1900	GPRS	27.7	26.94	0.10	Left	Tilt	06715	2	1:4.15	0.089	1.191	0.106	
ANSI / IEEE C95.1 1992 - SAFETY LIMIT Spatial Peak Uncontrolled Exposure/General Population							Head 1.6 W/kg (mW/g) averaged over 1 gram								

**Table 11-6
UMTS 850 Head SAR**

MEASUREMENT RESULTS														
FREQUENCY		Mode/Band	Service	Maximum Allowed Power [dBm]	Conducted Power [dBm]	Power Drift [dB]	Side	Test Position	Device Serial Number	Duty Cycle	SAR (1g)	Scaling Factor	Reported SAR (1g)	Plot #
MHz	Ch.										(W/kg)		(W/kg)	
836.60	4183	UMTS 850	RMC	23.7	23.56	0.00	Right	Cheek	06731	1:1	0.406	1.033	0.419	A6
836.60	4183	UMTS 850	RMC	23.7	23.56	0.02	Right	Tilt	06731	1:1	0.188	1.033	0.194	
836.60	4183	UMTS 850	RMC	23.7	23.56	0.01	Left	Cheek	06731	1:1	0.325	1.033	0.336	
836.60	4183	UMTS 850	RMC	23.7	23.56	0.03	Left	Tilt	06731	1:1	0.200	1.033	0.207	
ANSI / IEEE C95.1 1992 - SAFETY LIMIT Spatial Peak Uncontrolled Exposure/General Population							Head 1.6 W/kg (mW/g) averaged over 1 gram							

**Table 11-7
UMTS 1750 Head SAR**

MEASUREMENT RESULTS														
FREQUENCY		Mode/Band	Service	Maximum Allowed Power [dBm]	Conducted Power [dBm]	Power Drift [dB]	Side	Test Position	Device Serial Number	Duty Cycle	SAR (1g)	Scaling Factor	Reported SAR (1g)	Plot #
MHz	Ch.										(W/kg)		(W/kg)	
1732.40	1412	UMTS 1750	RMC	22.7	22.59	-0.06	Right	Cheek	06715	1:1	0.302	1.026	0.310	
1732.40	1412	UMTS 1750	RMC	22.7	22.59	0.02	Right	Tilt	06715	1:1	0.168	1.026	0.172	
1732.40	1412	UMTS 1750	RMC	22.7	22.59	0.02	Left	Cheek	06715	1:1	0.455	1.026	0.467	A7
1732.40	1412	UMTS 1750	RMC	22.7	22.59	-0.02	Left	Tilt	06715	1:1	0.180	1.026	0.185	
ANSI / IEEE C95.1 1992 - SAFETY LIMIT Spatial Peak Uncontrolled Exposure/General Population							Head 1.6 W/kg (mW/g) averaged over 1 gram							

FCC ID: ZNFLS450		SAR EVALUATION REPORT		Reviewed by: Quality Manager
Document S/N: OY1604060711-R1.ZNF	Test Dates: 04/05/16 - 04/11/16	DUT Type: Portable Handset		Page 40 of 59

**Table 11-8
UMTS 1900 Head SAR**



MEASUREMENT RESULTS														
FREQUENCY		Mode/Band	Service	Maximum Allowed Power [dBm]	Conducted Power [dBm]	Power Drift [dB]	Side	Test Position	Device Serial Number	Duty Cycle	SAR (1g)	Scaling Factor	Reported SAR (1g)	Plot #
MHz	Ch.										(W/kg)		(W/kg)	
1880.00	9400	UMTS 1900	RMC	23.7	23.56	-0.09	Right	Cheek	06715	1:1	1.033	0.318	0.328	
1880.00	9400	UMTS 1900	RMC	23.7	23.56	-0.01	Right	Tilt	06715	1:1	1.033	0.206	0.213	
1880.00	9400	UMTS 1900	RMC	23.7	23.56	-0.15	Left	Cheek	06715	1:1	1.033	0.550	0.568	A8
1880.00	9400	UMTS 1900	RMC	23.7	23.56	-0.04	Left	Tilt	06715	1:1	1.033	0.178	0.184	
ANSI / IEEE C95.1 1992 - SAFETY LIMIT Spatial Peak Uncontrolled Exposure/General Population								Head 1.6 W/kg (mW/g) averaged over 1 gram						

**Table 11-9
LTE Band 12 Head SAR**

MEASUREMENT RESULTS																			
FREQUENCY		Mode	Bandwidth [MHz]	Maximum Allowed Power [dBm]	Conducted Power [dBm]	Power Drift [dB]	MPR [dB]	Side	Test Position	Modulation	RB Size	RB Offset	Device Serial Number	Duty Cycle	SAR (1g)	Scaling Factor	Reported SAR (1g)	Plot #	
MHz	Ch.														(W/kg)		(W/kg)		
707.50	23095	Mid	LTE Band 12	10	24.8	24.71	-0.03	0	Right	Cheek	QPSK	1	25	06731	1:1	1.021	0.240	0.245	A9
707.50	23095	Mid	LTE Band 12	10	23.8	23.69	-0.04	1	Right	Cheek	QPSK	25	12	06731	1:1	1.026	0.172	0.176	
707.50	23095	Mid	LTE Band 12	10	24.8	24.71	0.05	0	Right	Tilt	QPSK	1	25	06731	1:1	1.021	0.118	0.120	
707.50	23095	Mid	LTE Band 12	10	23.8	23.69	0.19	1	Right	Tilt	QPSK	25	12	06731	1:1	1.026	0.089	0.091	
707.50	23095	Mid	LTE Band 12	10	24.8	24.71	0.12	0	Left	Cheek	QPSK	1	25	06731	1:1	1.021	0.231	0.236	
707.50	23095	Mid	LTE Band 12	10	23.8	23.69	0.14	1	Left	Cheek	QPSK	25	12	03731	1:1	1.026	0.155	0.159	
707.50	23095	Mid	LTE Band 12	10	24.8	24.71	-0.09	0	Left	Tilt	QPSK	1	25	06731	1:1	1.021	0.126	0.129	
707.50	23095	Mid	LTE Band 12	10	23.8	23.69	0.08	1	Left	Tilt	QPSK	25	12	06731	1:1	1.026	0.084	0.086	
ANSI / IEEE C95.1 1992 - SAFETY LIMIT Spatial Peak Uncontrolled Exposure/General Population										Head 1.6 W/kg (mW/g) averaged over 1 gram									

**Table 11-10
LTE Band 26 (Cell) Head SAR**

MEASUREMENT RESULTS																			
FREQUENCY		Mode	Bandwidth [MHz]	Maximum Allowed Power [dBm]	Conducted Power [dBm]	Power Drift [dB]	MPR [dB]	Side	Test Position	Modulation	RB Size	RB Offset	Device Serial Number	Duty Cycle	SAR (1g)	Scaling Factor	Reported SAR (1g)	Plot #	
MHz	Ch.														(W/kg)		(W/kg)		
836.50	26915	Mid	LTE Band 26 (Cell)	15	24.0	24.00	0.11	0	Right	Cheek	QPSK	1	74	06731	1:1	1.000	0.425	0.425	A10
836.50	26915	Mid	LTE Band 26 (Cell)	15	23.0	22.79	0.02	1	Right	Cheek	QPSK	36	0	06731	1:1	1.050	0.338	0.355	
836.50	26915	Mid	LTE Band 26 (Cell)	15	24.0	24.00	0.11	0	Right	Tilt	QPSK	1	74	06731	1:1	1.000	0.218	0.218	
836.50	26915	Mid	LTE Band 26 (Cell)	15	23.0	22.79	0.02	1	Right	Tilt	QPSK	36	0	06731	1:1	1.050	0.166	0.174	
836.50	26915	Mid	LTE Band 26 (Cell)	15	24.0	24.00	0.01	0	Left	Cheek	QPSK	1	74	06731	1:1	1.000	0.366	0.366	
836.50	26915	Mid	LTE Band 26 (Cell)	15	23.0	22.79	-0.01	1	Left	Cheek	QPSK	36	0	06731	1:1	1.050	0.293	0.308	
836.50	26915	Mid	LTE Band 26 (Cell)	15	24.0	24.00	0.16	0	Left	Tilt	QPSK	1	74	06731	1:1	1.000	0.210	0.210	
836.50	26915	Mid	LTE Band 26 (Cell)	15	23.0	22.79	0.16	1	Left	Tilt	QPSK	36	0	06731	1:1	1.050	0.172	0.181	
ANSI / IEEE C95.1 1992 - SAFETY LIMIT Spatial Peak Uncontrolled Exposure/General Population										Head 1.6 W/kg (mW/g) averaged over 1 gram									

FCC ID: ZNFLS450		SAR EVALUATION REPORT		Reviewed by: Quality Manager
Document S/N: OY1604060711-R1.ZNF	Test Dates: 04/05/16 - 04/11/16	DUT Type: Portable Handset		Page 41 of 59

**Table 11-11
LTE Band 4 (AWS) Head SAR**



MEASUREMENT RESULTS																			
FREQUENCY		Mode	Bandwidth [MHz]	Maximum Allowed Power [dBm]	Conducted Power [dBm]	Power Drift [dB]	MPR [dB]	Side	Test Position	Modulation	RB Size	RB Offset	Device Serial Number	Duty Cycle	SAR (1g)	Scaling Factor	Reported SAR (1g)	Plot #	
MHz	Ch.														(W/kg)		(W/kg)		
1732.50	20175	Mid	LTE Band 4 (AWS)	20	23.2	23.01	-0.14	0	Right	Cheek	QPSK	1	50	06731	1:1	0.282	1.045	0.295	
1732.50	20175	Mid	LTE Band 4 (AWS)	20	22.2	21.99	0.10	1	Right	Cheek	QPSK	50	25	06731	1:1	0.223	1.050	0.234	
1732.50	20175	Mid	LTE Band 4 (AWS)	20	23.2	23.01	0.09	0	Right	Tilt	QPSK	1	50	06731	1:1	0.163	1.045	0.170	
1732.50	20175	Mid	LTE Band 4 (AWS)	20	22.2	21.99	0.02	1	Right	Tilt	QPSK	50	25	06731	1:1	0.128	1.050	0.134	
1732.50	20175	Mid	LTE Band 4 (AWS)	20	23.2	23.01	0.21	0	Left	Cheek	QPSK	1	50	06731	1:1	0.390	1.045	0.408	A11
1732.50	20175	Mid	LTE Band 4 (AWS)	20	22.2	21.99	-0.14	1	Left	Cheek	QPSK	50	25	06731	1:1	0.325	1.050	0.341	
1732.50	20175	Mid	LTE Band 4 (AWS)	20	23.2	23.01	-0.07	0	Left	Tilt	QPSK	1	50	06731	1:1	0.167	1.045	0.175	
1732.50	20175	Mid	LTE Band 4 (AWS)	20	22.2	21.99	0.11	1	Left	Tilt	QPSK	50	25	06731	1:1	0.139	1.050	0.146	
ANSI / IEEE C95.1 1992 - SAFETY LIMIT Spatial Peak Uncontrolled Exposure/General Population										Head 1.6 W/kg (mW/g) averaged over 1 gram									

**Table 11-12
LTE Band 25 (PCS) Head SAR**

MEASUREMENT RESULTS																			
FREQUENCY		Mode	Bandwidth [MHz]	Maximum Allowed Power [dBm]	Conducted Power [dBm]	Power Drift [dB]	MPR [dB]	Side	Test Position	Modulation	RB Size	RB Offset	Device Serial Number	Duty Cycle	SAR (1g)	Scaling Factor	Reported SAR (1g)	Plot #	
MHz	Ch.														(W/kg)		(W/kg)		
1882.50	26365	Mid	LTE Band 25 (PCS)	20	23.7	23.62	0.10	0	Right	Cheek	QPSK	1	50	06731	1:1	0.285	1.019	0.290	
1882.50	26365	Mid	LTE Band 25 (PCS)	20	22.7	22.62	0.06	1	Right	Cheek	QPSK	50	25	06731	1:1	0.198	1.019	0.202	
1882.50	26365	Mid	LTE Band 25 (PCS)	20	23.7	23.62	0.14	0	Right	Tilt	QPSK	1	50	06731	1:1	0.170	1.019	0.173	
1882.50	26365	Mid	LTE Band 25 (PCS)	20	22.7	22.62	-0.04	1	Right	Tilt	QPSK	50	25	06731	1:1	0.128	1.019	0.130	
1882.50	26365	Mid	LTE Band 25 (PCS)	20	23.7	23.62	0.04	0	Left	Cheek	QPSK	1	50	06731	1:1	0.498	1.019	0.507	A12
1882.50	26365	Mid	LTE Band 25 (PCS)	20	22.7	22.62	0.05	1	Left	Cheek	QPSK	50	25	06731	1:1	0.382	1.019	0.389	
1882.50	26365	Mid	LTE Band 25 (PCS)	20	23.7	23.62	0.07	0	Left	Tilt	QPSK	1	50	06731	1:1	0.165	1.019	0.168	
1882.50	26365	Mid	LTE Band 25 (PCS)	20	22.7	22.62	0.08	1	Left	Tilt	QPSK	50	25	06731	1:1	0.125	1.019	0.127	
ANSI / IEEE C95.1 1992 - SAFETY LIMIT Spatial Peak Uncontrolled Exposure/General Population										Head 1.6 W/kg (mW/g) averaged over 1 gram									

**Table 11-13
LTE Band 41 Head SAR**

MEASUREMENT RESULTS																				
FREQUENCY		Mode	Bandwidth [MHz]	Maximum Allowed Power [dBm]	Conducted Power [dBm]	Power Drift [dB]	MPR [dB]	Side	Test Position	Modulation	RB Size	RB Offset	Device Serial Number	Duty Cycle	SAR (1g)	Scaling Factor (Power)	Scaling Factor (Extended Cyclic Prefix)	Reported SAR (1g)	Plot #	
MHz	Ch.														(W/kg)		(W/kg)	(W/kg)		
2680.00	41490	High	LTE Band 41	20	23.5	23.42	0.00	0	Right	Cheek	QPSK	1	0	06731	1:1.59	0.425	1.019	1.01	0.437	A13
2636.50	41055	Mid-High	LTE Band 41	20	22.5	22.41	-0.16	1	Right	Cheek	QPSK	50	0	06731	1:1.59	0.334	1.021	1.01	0.344	
2680.00	41490	High	LTE Band 41	20	23.5	23.42	-0.03	0	Right	Tilt	QPSK	1	0	06731	1:1.59	0.112	1.019	1.01	0.115	
2636.50	41055	Mid-High	LTE Band 41	20	22.5	22.41	0.13	1	Right	Tilt	QPSK	50	0	06731	1:1.59	0.085	1.021	1.01	0.088	
2680.00	41490	High	LTE Band 41	20	23.5	23.42	-0.07	0	Left	Cheek	QPSK	1	0	06731	1:1.59	0.220	1.019	1.01	0.226	
2636.50	41055	Mid-High	LTE Band 41	20	22.5	22.41	0.18	1	Left	Cheek	QPSK	50	0	06731	1:1.59	0.175	1.021	1.01	0.181	
2680.00	41490	High	LTE Band 41	20	23.5	23.42	-0.20	0	Left	Tilt	QPSK	1	0	06731	1:1.59	0.061	1.019	1.01	0.063	
2636.50	41055	Mid-High	LTE Band 41	20	22.5	22.41	-0.04	1	Left	Tilt	QPSK	50	0	06731	1:1.59	0.054	1.021	1.01	0.056	
ANSI / IEEE C95.1 1992 - SAFETY LIMIT Spatial Peak Uncontrolled Exposure/General Population										Head 1.6 W/kg (mW/g) averaged over 1 gram										

FCC ID: ZNFLS450		SAR EVALUATION REPORT		Reviewed by: Quality Manager
Document S/N: OY1604060711-R1.ZNF	Test Dates: 04/05/16 - 04/11/16	DUT Type: Portable Handset		Page 42 of 59

**Table 11-14
DTS Head SAR**



MEASUREMENT RESULTS																		
FREQUENCY		Mode	Service	Bandwidth [MHz]	Maximum Allowed Power [dBm]	Conducted Power [dBm]	Power Drift [dB]	Side	Test Position	Device Serial Number	Data Rate (Mbps)	Duty Cycle (%)	Peak SAR of Area Scan	SAR (1g)	Scaling Factor (Power)	Scaling Factor (Duty Cycle)	Reported SAR (1g)	Plot #
MHz	Ch.												W/kg	(W/kg)			(W/kg)	
2437	6	802.11b	DSSS	22	16.0	15.99	-0.02	Right	Cheek	06723	1	99.6	0.725	0.610	1.002	1.004	0.613	A14
2437	6	802.11b	DSSS	22	16.0	15.99	0.13	Right	Tilt	06723	1	99.6	0.421	0.325	1.002	1.004	0.327	
2437	6	802.11b	DSSS	22	16.0	15.99	0.11	Left	Cheek	06723	1	99.6	0.253	-	1.002	1.004	-	
2437	6	802.11b	DSSS	22	16.0	15.99	0.01	Left	Tilt	06723	1	99.6	0.170	-	1.002	1.004	-	
ANSI / IEEE C95.1 1992 - SAFETY LIMIT Spatial Peak Uncontrolled Exposure/General Population									Head 1.6 W/kg (mW/g) averaged over 1 gram									

11.2 Standalone Body-Worn SAR Data

**Table 11-15
GSM/UMTS/CDMA Body-Worn SAR Data**

MEASUREMENT RESULTS																	
FREQUENCY		Mode	Service	Maximum Allowed Power [dBm]	Conducted Power [dBm]	Power Drift [dB]	Spacing	Device Serial Number	# of Time Slots	Duty Cycle	Side	SAR (1g)	Scaling Factor	Reported SAR (1g)	Plot #		
MHz	Ch.											(W/kg)		(W/kg)			
820.10	564	CDMA BC10 (§90S)	TDSO / SO32	25.0	24.90	-0.01	10 mm	06715	N/A	1:1	back	0.929	1.023	0.950	A15		
820.10	564	CDMA BC10 (§90S)	TDSO / SO32	25.0	24.90	0.01	10 mm	06715	N/A	1:1	back	0.900	1.023	0.921			
824.70	1013	CDMA BC0 (§22H)	TDSO / SO32	24.7	24.55	-0.04	10 mm	06715	N/A	1:1	back	0.886	1.035	0.917			
836.52	384	CDMA BC0 (§22H)	TDSO / SO32	24.7	24.61	-0.05	10 mm	06715	N/A	1:1	back	0.887	1.021	0.906	A17		
848.31	777	CDMA BC0 (§22H)	TDSO / SO32	24.7	24.61	0.02	10 mm	06715	N/A	1:1	back	0.850	1.021	0.868			
1851.25	25	PCS CDMA	TDSO / SO32	24.4	23.90	0.01	10 mm	06715	N/A	1:1	back	0.797	1.122	0.894	A19		
1880.00	600	PCS CDMA	TDSO / SO32	24.4	23.92	0.16	10 mm	06715	N/A	1:1	back	0.753	1.117	0.841			
1908.75	1175	PCS CDMA	TDSO / SO32	24.4	23.78	0.02	10 mm	06715	N/A	1:1	back	0.757	1.153	0.873			
836.60	190	GSM 850	GSM	33.2	32.60	0.02	10 mm	06715	1	1.8.3	back	0.624	1.148	0.716			
824.20	128	GSM 850	GPRS	31.7	31.03	0.11	10 mm	06715	2	1.4.15	back	0.799	1.167	0.932	A21		
836.60	190	GSM 850	GPRS	31.7	31.12	-0.03	10 mm	06715	2	1.4.15	back	0.706	1.143	0.807			
848.80	251	GSM 850	GPRS	31.7	30.79	0.00	10 mm	06715	2	1.4.15	back	0.796	1.233	0.981			
1880.00	661	GSM 1900	GSM	30.2	29.63	-0.01	10 mm	06715	1	1.8.3	back	0.346	1.140	0.394	A22		
1880.00	661	GSM 1900	GPRS	27.7	26.94	-0.17	10 mm	06715	2	1.4.15	back	0.330	1.191	0.393			
836.60	4183	UMTS 850	RMC	23.7	23.56	0.06	10 mm	06723	N/A	1:1	back	0.572	1.033	0.591	A24		
1712.40	1312	UMTS 1750	RMC	22.7	22.49	0.09	10 mm	06715	N/A	1:1	back	0.949	1.050	0.996			
1732.40	1412	UMTS 1750	RMC	22.7	22.59	-0.03	10 mm	06715	N/A	1:1	back	0.986	1.026	1.012	A25		
1752.60	1513	UMTS 1750	RMC	22.7	22.62	0.00	10 mm	06715	N/A	1:1	back	0.868	1.019	0.884			
1732.40	1412	UMTS 1750	RMC	22.7	22.59	0.03	10 mm	06715	N/A	1:1	back	0.909	1.026	0.933			
1880.00	9400	UMTS 1900	RMC	23.7	23.56	0.08	10 mm	06715	N/A	1:1	back	0.773	1.033	0.799	A26		
ANSI / IEEE C95.1 1992 - SAFETY LIMIT Spatial Peak Uncontrolled Exposure/General Population									Body 1.6 W/kg (mW/g) averaged over 1 gram								

Blue entries represent variability data.



FCC ID: ZNFLS450		SAR EVALUATION REPORT		Reviewed by: Quality Manager
Document S/N: OY1604060711-R1.ZNF	Test Dates: 04/05/16 - 04/11/16	DUT Type: Portable Handset		Page 43 of 59

**Table 11-16
LTE Body-Worn SAR**

MEASUREMENT RESULTS																			
FREQUENCY		Mode	Bandwidth [MHz]	Maximum Allowed Power [dBm]	Conducted Power [dBm]	Power Drift [dB]	MPR [dB]	Device Serial Number	Modulation	RB Size	RB Offset	Spacing	Side	Duty Cycle	SAR (1g)	Scaling Factor	Scaling Factor (Extended Cyclic Prefix)	Reported SAR (1g)	Plot #
MHz	Ch.														(W/kg)			(W/kg)	
707.50	23095	Mid	LTE Band 12	10	24.8	24.71	-0.05	0	06731	QPSK	1	25	10 mm	back	1:1	1.021	N/A	0.456	A27
707.50	23095	Mid	LTE Band 12	10	23.8	23.69	0.06	1	06731	QPSK	25	12	10 mm	back	1:1	1.026	N/A	0.334	
836.50	26915	Mid	LTE Band 26 (Cell)	15	24.0	24.00	0.14	0	06731	QPSK	1	74	10 mm	back	1:1	1.000	N/A	0.707	A28
836.50	26915	Mid	LTE Band 26 (Cell)	15	23.0	22.79	0.01	1	06731	QPSK	36	0	10 mm	back	1:1	1.050	N/A	0.564	
1732.50	20175	Mid	LTE Band 4 (AWS)	20	23.2	23.01	0.12	0	06731	QPSK	1	50	10 mm	back	1:1	1.045	N/A	0.977	A29
1732.50	20175	Mid	LTE Band 4 (AWS)	20	22.2	21.99	-0.10	1	06731	QPSK	50	25	10 mm	back	1:1	1.050	N/A	0.733	
1732.50	20175	Mid	LTE Band 4 (AWS)	20	22.2	21.96	0.01	1	06731	QPSK	100	0	10 mm	back	1:1	1.057	N/A	0.729	
1882.50	26365	Mid	LTE Band 25 (PCS)	20	23.7	23.62	0.09	0	06731	QPSK	1	50	10 mm	back	1:1	1.019	N/A	0.593	A30
1882.50	26365	Mid	LTE Band 25 (PCS)	20	22.7	22.62	-0.08	1	06731	QPSK	50	25	10 mm	back	1:1	1.019	N/A	0.458	
2680.00	41490	High	LTE Band 41	20	23.5	23.42	-0.06	0	06731	QPSK	1	0	10 mm	back	1:1.59	1.019	1.01	0.382	A31
2636.50	41055	Mid-High	LTE Band 41	20	22.5	22.41	0.01	1	06731	QPSK	50	0	10 mm	back	1:1.59	1.021	1.01	0.285	
ANSI / IEEE C95.1 1992 - SAFETY LIMIT Spatial Peak Uncontrolled Exposure/General Population										Body 1.6 W/kg (mW/g) averaged over 1 gram									

**Table 11-17
DTS Body-Worn SAR**

MEASUREMENT RESULTS																		
FREQUENCY		Mode	Service	Bandwidth [MHz]	Maximum Allowed Power [dBm]	Conducted Power [dBm]	Power Drift [dB]	Spacing	Device Serial Number	Data Rate (Mbps)	Side	Duty Cycle (%)	Peak SAR of Area Scan	SAR (1g)	Scaling Factor (Power)	Scaling Factor (Duty Cycle)	Reported SAR (1g)	Plot #
MHz	Ch.												(W/kg)	(W/kg)			(W/kg)	
2437	6	802.11b	DSSS	22	16.0	15.99	0.05	10 mm	06723	1	back	99.6	0.155	0.118	1.002	1.004	0.118	A33
ANSI / IEEE C95.1 1992 - SAFETY LIMIT Spatial Peak Uncontrolled Exposure/General Population										Body 1.6 W/kg (mW/g) averaged over 1 gram								



FCC ID: ZNFLS450		SAR EVALUATION REPORT		Reviewed by: Quality Manager
Document S/N: OY1604060711-R1.ZNF	Test Dates: 04/05/16 - 04/11/16	DUT Type: Portable Handset		Page 44 of 59

11.3 Standalone Hotspot SAR Data

**Table 11-18
GPRS/UMTS/CDMA Hotspot SAR Data**

MEASUREMENT RESULTS															
FREQUENCY		Mode	Service	Maximum Allowed Power [dBm]	Conducted Power [dBm]	Power Drift [dB]	Spacing	Device Serial Number	# of GPRS Slots	Duty Cycle	Side	SAR (1g)	Scaling Factor	Reported SAR (1g)	Plot #
MHz	Ch.											(W/kg)		(W/kg)	
820.10	564	CDMABC10 (\$90S)	EVDO Rev. 0	25.0	24.65	0.04	10 mm	06715	N/A	1:1	back	0.894	1.084	0.969	A16
820.10	564	CDMABC10 (\$90S)	EVDO Rev. 0	25.0	24.65	0.02	10 mm	06715	N/A	1:1	front	0.626	1.084	0.679	
820.10	564	CDMABC10 (\$90S)	EVDO Rev. 0	25.0	24.65	0.07	10 mm	06715	N/A	1:1	bottom	0.108	1.084	0.117	
820.10	564	CDMABC10 (\$90S)	EVDO Rev. 0	25.0	24.65	0.00	10 mm	06715	N/A	1:1	right	0.579	1.084	0.628	
820.10	564	CDMABC10 (\$90S)	EVDO Rev. 0	25.0	24.65	-0.01	10 mm	06715	N/A	1:1	left	0.616	1.084	0.668	
824.70	1013	CDMABC0 (\$22H)	EVDO Rev. 0	24.7	24.60	-0.10	10 mm	06715	N/A	1:1	back	0.864	1.023	0.884	
836.52	384	CDMABC0 (\$22H)	EVDO Rev. 0	24.7	24.51	0.05	10 mm	06715	N/A	1:1	back	0.883	1.045	0.923	A18
848.31	777	CDMABC0 (\$22H)	EVDO Rev. 0	24.7	24.58	0.00	10 mm	06715	N/A	1:1	back	0.855	1.028	0.879	
836.52	384	CDMABC0 (\$22H)	EVDO Rev. 0	24.7	24.51	0.05	10 mm	06715	N/A	1:1	front	0.659	1.045	0.689	
836.52	384	CDMABC0 (\$22H)	EVDO Rev. 0	24.7	24.51	0.09	10 mm	06715	N/A	1:1	bottom	0.156	1.045	0.163	
836.52	384	CDMABC0 (\$22H)	EVDO Rev. 0	24.7	24.51	0.03	10 mm	06715	N/A	1:1	right	0.636	1.045	0.665	
836.52	384	CDMABC0 (\$22H)	EVDO Rev. 0	24.7	24.51	0.10	10 mm	06715	N/A	1:1	left	0.630	1.045	0.658	
1880.00	600	PCS CDMA	EVDO Rev. 0	24.4	24.00	-0.01	10 mm	06715	N/A	1:1	back	0.678	1.096	0.743	
1851.25	25	PCS CDMA	EVDO Rev. 0	24.4	23.92	-0.02	10 mm	06715	N/A	1:1	front	0.708	1.117	0.791	
1880.00	600	PCS CDMA	EVDO Rev. 0	24.4	24.00	0.02	10 mm	06715	N/A	1:1	front	0.730	1.096	0.800	
1908.75	1175	PCS CDMA	EVDO Rev. 0	24.4	23.83	-0.04	10 mm	06715	N/A	1:1	front	0.788	1.140	0.898	A20
1880.00	600	PCS CDMA	EVDO Rev. 0	24.4	24.00	0.16	10 mm	06715	N/A	1:1	bottom	0.315	1.096	0.345	
1880.00	600	PCS CDMA	EVDO Rev. 0	24.4	24.00	-0.14	10 mm	06715	N/A	1:1	left	0.491	1.096	0.538	
824.20	128	GSM 850	GPRS	31.7	31.03	0.11	10 mm	06715	2	1:4.15	back	0.799	1.167	0.932	A21
836.60	190	GSM 850	GPRS	31.7	31.12	-0.03	10 mm	06715	2	1:4.15	back	0.706	1.143	0.807	
848.80	251	GSM 850	GPRS	31.7	30.79	0.00	10 mm	06715	2	1:4.15	back	0.796	1.233	0.981	
836.60	190	GSM 850	GPRS	31.7	31.12	-0.02	10 mm	06715	2	1:4.15	front	0.526	1.143	0.601	
836.60	190	GSM 850	GPRS	31.7	31.12	-0.02	10 mm	06715	2	1:4.15	bottom	0.130	1.143	0.149	
836.60	190	GSM 850	GPRS	31.7	31.12	0.08	10 mm	06715	2	1:4.15	right	0.548	1.143	0.626	
836.60	190	GSM 850	GPRS	31.7	31.12	0.04	10 mm	06715	2	1:4.15	left	0.507	1.143	0.580	
1880.00	661	GSM 1900	GPRS	27.7	26.94	-0.17	10 mm	06715	2	1:4.15	back	0.330	1.191	0.393	A23
1880.00	661	GSM 1900	GPRS	27.7	26.94	-0.10	10 mm	06715	2	1:4.15	front	0.292	1.191	0.348	
1880.00	661	GSM 1900	GPRS	27.7	26.94	0.02	10 mm	06715	2	1:4.15	bottom	0.136	1.191	0.162	
1880.00	661	GSM 1900	GPRS	27.7	26.94	0.09	10 mm	06715	2	1:4.15	left	0.205	1.191	0.244	
836.60	4183	UMTS 850	RMC	23.7	23.56	0.06	10 mm	06723	N/A	1:1	back	0.572	1.033	0.591	A24
836.60	4183	UMTS 850	RMC	23.7	23.56	0.00	10 mm	06723	N/A	1:1	front	0.427	1.033	0.441	
836.60	4183	UMTS 850	RMC	23.7	23.56	0.14	10 mm	06723	N/A	1:1	bottom	0.094	1.033	0.097	
836.60	4183	UMTS 850	RMC	23.7	23.56	-0.13	10 mm	06723	N/A	1:1	right	0.430	1.033	0.444	
836.60	4183	UMTS 850	RMC	23.7	23.56	-0.06	10 mm	06723	N/A	1:1	left	0.384	1.033	0.397	
1712.40	1312	UMTS 1750	RMC	22.7	22.49	0.09	10 mm	06715	N/A	1:1	back	0.949	1.050	0.996	
1732.40	1412	UMTS 1750	RMC	22.7	22.59	-0.03	10 mm	06715	N/A	1:1	back	0.986	1.026	1.012	A25
1752.60	1513	UMTS 1750	RMC	22.7	22.62	0.00	10 mm	06715	N/A	1:1	back	0.868	1.019	0.884	
1732.40	1412	UMTS 1750	RMC	22.7	22.59	0.00	10 mm	06715	N/A	1:1	front	0.648	1.026	0.665	
1732.40	1412	UMTS 1750	RMC	22.7	22.59	0.15	10 mm	06715	N/A	1:1	bottom	0.254	1.026	0.261	
1732.40	1412	UMTS 1750	RMC	22.7	22.59	-0.13	10 mm	06715	N/A	1:1	left	0.347	1.026	0.356	
1732.40	1412	UMTS 1750	RMC	22.7	22.59	0.03	10 mm	06715	N/A	1:1	back	0.909	1.026	0.933	
1880.00	9400	UMTS 1900	RMC	23.7	23.56	0.08	10 mm	06715	N/A	1:1	back	0.773	1.033	0.799	A26
1880.00	9400	UMTS 1900	RMC	23.7	23.56	-0.02	10 mm	06715	N/A	1:1	front	0.696	1.033	0.719	
1880.00	9400	UMTS 1900	RMC	23.7	23.56	-0.07	10 mm	06715	N/A	1:1	bottom	0.289	1.033	0.299	
1880.00	9400	UMTS 1900	RMC	23.7	23.56	0.00	10 mm	06715	N/A	1:1	left	0.442	1.033	0.457	
ANSI / IEEE C95.1 1992 - SAFETY LIMIT							Body								
Spatial Peak							1.6 W/kg (mW/g)								
Uncontrolled Exposure/General Population							averaged over 1 gram								

Blue entries represent variability data.

FCC ID: ZNFLS450		SAR EVALUATION REPORT			Reviewed by: Quality Manager
Document S/N: OY1604060711-R1.ZNF	Test Dates: 04/05/16 - 04/11/16	DUT Type: Portable Handset			Page 45 of 59

**Table 11-19
LTE Band 12 Hotspot SAR**



MEASUREMENT RESULTS																			
FREQUENCY		Mode	Bandwidth [MHz]	Maximum Allowed Power [dBm]	Conducted Power [dBm]	Power Drift [dB]	MPR [dB]	Device Serial Number	Modulation	RB Size	RB Offset	Spacing	Side	Duty Cycle	SAR (1g)	Scaling Factor	Reported SAR (1g)	Plot #	
MHz	Ch.														(W/kg)		(W/kg)		
707.50	23095	Mid	LTE Band 12	10	24.8	24.71	-0.05	0	06731	QPSK	1	25	10 mm	back	1:1	0.447	1.021	0.456	A27
707.50	23095	Mid	LTE Band 12	10	23.8	23.69	0.06	1	06731	QPSK	25	12	10 mm	back	1:1	0.326	1.026	0.334	
707.50	23095	Mid	LTE Band 12	10	24.8	24.71	-0.05	0	06731	QPSK	1	25	10 mm	front	1:1	0.237	1.021	0.242	
707.50	23095	Mid	LTE Band 12	10	23.8	23.69	-0.08	1	06731	QPSK	25	12	10 mm	front	1:1	0.169	1.026	0.173	
707.50	23095	Mid	LTE Band 12	10	24.8	24.71	0.12	0	06731	QPSK	1	25	10 mm	bottom	1:1	0.053	1.021	0.054	
707.50	23095	Mid	LTE Band 12	10	23.8	23.69	0.17	1	06731	QPSK	25	12	10 mm	bottom	1:1	0.039	1.026	0.040	
707.50	23095	Mid	LTE Band 12	10	24.8	24.71	0.06	0	06731	QPSK	1	25	10 mm	right	1:1	0.193	1.021	0.197	
707.50	23095	Mid	LTE Band 12	10	23.8	23.69	-0.11	1	06731	QPSK	25	12	10 mm	right	1:1	0.143	1.026	0.147	
707.50	23095	Mid	LTE Band 12	10	24.8	24.71	0.18	0	06731	QPSK	1	25	10 mm	left	1:1	0.111	1.021	0.113	
707.50	23095	Mid	LTE Band 12	10	23.8	23.69	0.02	1	06731	QPSK	25	12	10 mm	left	1:1	0.088	1.026	0.090	
ANSI / IEEE C95.1 1992 - SAFETY LIMIT Spatial Peak Uncontrolled Exposure/General Population								Body 1.6 W/kg (mW/g) averaged over 1 gram											

**Table 11-20
LTE Band 26 (Cell) Hotspot SAR**

MEASUREMENT RESULTS																			
FREQUENCY		Mode	Bandwidth [MHz]	Maximum Allowed Power [dBm]	Conducted Power [dBm]	Power Drift [dB]	MPR [dB]	Device Serial Number	Modulation	RB Size	RB Offset	Spacing	Side	Duty Cycle	SAR (1g)	Scaling Factor	Reported SAR (1g)	Plot #	
MHz	Ch.														(W/kg)		(W/kg)		
836.50	26915	Mid	LTE Band 26 (Cell)	15	24.0	24.00	0.14	0	06731	QPSK	1	74	10 mm	back	1:1	0.707	1.000	0.707	A28
836.50	26915	Mid	LTE Band 26 (Cell)	15	23.0	22.79	0.01	1	06731	QPSK	36	0	10 mm	back	1:1	0.537	1.050	0.564	
836.50	26915	Mid	LTE Band 26 (Cell)	15	24.0	24.00	-0.03	0	06731	QPSK	1	74	10 mm	front	1:1	0.515	1.000	0.515	
836.50	26915	Mid	LTE Band 26 (Cell)	15	23.0	22.79	0.03	1	06731	QPSK	36	0	10 mm	front	1:1	0.388	1.050	0.407	
836.50	26915	Mid	LTE Band 26 (Cell)	15	24.0	24.00	0.06	0	06731	QPSK	1	74	10 mm	bottom	1:1	0.099	1.000	0.099	
836.50	26915	Mid	LTE Band 26 (Cell)	15	23.0	22.79	-0.11	1	06731	QPSK	36	0	10 mm	bottom	1:1	0.076	1.050	0.080	
836.50	26915	Mid	LTE Band 26 (Cell)	15	24.0	24.00	-0.11	0	06731	QPSK	1	74	10 mm	right	1:1	0.443	1.000	0.443	
836.50	26915	Mid	LTE Band 26 (Cell)	15	23.0	22.79	0.14	1	06731	QPSK	36	0	10 mm	right	1:1	0.364	1.050	0.382	
836.50	26915	Mid	LTE Band 26 (Cell)	15	24.0	24.00	-0.13	0	06731	QPSK	1	74	10 mm	left	1:1	0.483	1.000	0.483	
836.50	26915	Mid	LTE Band 26 (Cell)	15	23.0	22.79	-0.01	1	06731	QPSK	36	0	10 mm	left	1:1	0.363	1.050	0.381	
ANSI / IEEE C95.1 1992 - SAFETY LIMIT Spatial Peak Uncontrolled Exposure/General Population								Body 1.6 W/kg (mW/g) averaged over 1 gram											

**Table 11-21
LTE Band 4 (AWS) Hotspot SAR**

MEASUREMENT RESULTS																			
FREQUENCY		Mode	Bandwidth [MHz]	Maximum Allowed Power [dBm]	Conducted Power [dBm]	Power Drift [dB]	MPR [dB]	Device Serial Number	Modulation	RB Size	RB Offset	Spacing	Side	Duty Cycle	SAR (1g)	Scaling Factor	Reported SAR (1g)	Plot #	
MHz	Ch.														(W/kg)		(W/kg)		
1732.50	20175	Mid	LTE Band 4 (AWS)	20	23.2	23.01	0.12	0	06731	QPSK	1	50	10 mm	back	1:1	0.935	1.045	0.977	A29
1732.50	20175	Mid	LTE Band 4 (AWS)	20	22.2	21.99	-0.10	1	06731	QPSK	50	25	10 mm	back	1:1	0.698	1.050	0.733	
1732.50	20175	Mid	LTE Band 4 (AWS)	20	22.2	21.96	0.01	1	06731	QPSK	100	0	10 mm	back	1:1	0.690	1.057	0.729	
1732.50	20175	Mid	LTE Band 4 (AWS)	20	23.2	23.01	0.19	0	06731	QPSK	1	50	10 mm	front	1:1	0.692	1.045	0.723	
1732.50	20175	Mid	LTE Band 4 (AWS)	20	22.2	21.99	-0.10	1	06731	QPSK	50	25	10 mm	front	1:1	0.501	1.050	0.526	
1732.50	20175	Mid	LTE Band 4 (AWS)	20	23.2	23.01	0.01	0	06731	QPSK	1	50	10 mm	bottom	1:1	0.265	1.045	0.277	
1732.50	20175	Mid	LTE Band 4 (AWS)	20	22.2	21.99	0.01	1	06731	QPSK	50	25	10 mm	bottom	1:1	0.203	1.050	0.213	
1732.50	20175	Mid	LTE Band 4 (AWS)	20	23.2	23.01	0.02	0	06731	QPSK	1	50	10 mm	left	1:1	0.350	1.045	0.366	
1732.50	20175	Mid	LTE Band 4 (AWS)	20	22.2	21.99	0.08	1	06731	QPSK	50	25	10 mm	left	1:1	0.271	1.050	0.285	
ANSI / IEEE C95.1 1992 - SAFETY LIMIT Spatial Peak Uncontrolled Exposure/General Population								Body 1.6 W/kg (mW/g) averaged over 1 gram											

FCC ID: ZNFLS450		SAR EVALUATION REPORT		Reviewed by: Quality Manager
Document S/N: OY1604060711-R1.ZNF	Test Dates: 04/05/16 - 04/11/16	DUT Type: Portable Handset		Page 46 of 59

**Table 11-22
LTE Band 25 (PCS) Hotspot SAR**



MEASUREMENT RESULTS																			
FREQUENCY		Mode	Bandwidth [MHz]	Maximum Allowed Power [dBm]	Conducted Power [dBm]	Power Drift [dB]	MPR [dB]	Device Serial Number	Modulation	RB Size	RB Offset	Spacing	Side	Duty Cycle	SAR (1g)	Scaling Factor	Reported SAR (1g)	Plot #	
MHz	Ch.														(W/kg)		(W/kg)		
1882.50	26365	Mid	LTE Band 25 (PCS)	20	23.7	23.62	0.09	0	06731	QPSK	1	50	10 mm	back	1:1	0.582	1.019	0.593	A30
1882.50	26365	Mid	LTE Band 25 (PCS)	20	22.7	22.62	-0.08	1	06731	QPSK	50	25	10 mm	back	1:1	0.449	1.019	0.458	
1882.50	26365	Mid	LTE Band 25 (PCS)	20	23.7	23.62	0.19	0	06731	QPSK	1	50	10 mm	front	1:1	0.572	1.019	0.583	
1882.50	26365	Mid	LTE Band 25 (PCS)	20	22.7	22.62	-0.18	1	06731	QPSK	50	25	10 mm	front	1:1	0.390	1.019	0.397	
1882.50	26365	Mid	LTE Band 25 (PCS)	20	23.7	23.62	-0.02	0	06731	QPSK	1	50	10 mm	bottom	1:1	0.218	1.019	0.222	
1882.50	26365	Mid	LTE Band 25 (PCS)	20	22.7	22.62	0.04	1	06731	QPSK	50	25	10 mm	bottom	1:1	0.171	1.019	0.174	
1882.50	26365	Mid	LTE Band 25 (PCS)	20	23.7	23.62	0.05	0	06731	QPSK	1	50	10 mm	left	1:1	0.396	1.019	0.404	
1882.50	26365	Mid	LTE Band 25 (PCS)	20	22.7	22.62	0.05	1	06731	QPSK	50	25	10 mm	left	1:1	0.289	1.019	0.294	
ANSI / IEEE C95.1 1992 - SAFETY LIMIT Spatial Peak Uncontrolled Exposure/General Population									Body 1.6 W/kg (mW/g) averaged over 1 gram										

**Table 11-23
LTE Band 41 Hotspot SAR**

MEASUREMENT RESULTS																				
FREQUENCY		Mode	Bandwidth [MHz]	Maximum Allowed Power [dBm]	Conducted Power [dBm]	Power Drift [dB]	MPR [dB]	Device Serial Number	Modulation	RB Size	RB Offset	Spacing	Side	Duty Cycle	SAR (1g)	Scaling Factor (Powers)	Scaling Factor (Extended Cyclic Prefix)	Reported SAR (1g)	Plot #	
MHz	Ch.														(W/kg)		(W/kg)	(W/kg)		
2680.00	41490	High	LTE Band 41	20	23.5	23.42	-0.06	0	06731	QPSK	1	0	10 mm	back	1:1.59	0.371	1.019	1.01	0.362	A31
2636.50	41055	Mid-High	LTE Band 41	20	22.5	22.41	0.01	1	06731	QPSK	50	0	10 mm	back	1:1.59	0.276	1.021	1.01	0.285	
2680.00	41490	High	LTE Band 41	20	23.5	23.42	-0.08	0	06731	QPSK	1	0	10 mm	front	1:1.59	0.360	1.019	1.01	0.371	
2636.50	41055	Mid-High	LTE Band 41	20	22.5	22.41	0.00	1	06731	QPSK	50	0	10 mm	front	1:1.59	0.274	1.021	1.01	0.283	
2680.00	41490	High	LTE Band 41	20	23.5	23.42	0.12	0	06731	QPSK	1	0	10 mm	bottom	1:1.59	0.314	1.019	1.01	0.323	
2636.50	41055	Mid-High	LTE Band 41	20	22.5	22.41	-0.16	1	06731	QPSK	50	0	10 mm	bottom	1:1.59	0.210	1.021	1.01	0.216	
2680.00	41490	High	LTE Band 41	20	23.5	23.42	0.02	0	06731	QPSK	1	0	10 mm	right	1:1.59	0.106	1.019	1.01	0.109	
2636.50	41055	Mid-High	LTE Band 41	20	22.5	22.41	0.07	1	06731	QPSK	50	0	10 mm	right	1:1.59	0.078	1.021	1.01	0.081	
2680.00	41490	High	LTE Band 41	20	23.5	23.42	0.13	0	06731	QPSK	1	0	10 mm	left	1:1.59	0.080	1.019	1.01	0.083	
2636.50	41055	Mid-High	LTE Band 41	20	22.5	22.41	0.17	1	06731	QPSK	50	0	10 mm	left	1:1.59	0.047	1.021	1.01	0.048	
ANSI / IEEE C95.1 1992 - SAFETY LIMIT Spatial Peak Uncontrolled Exposure/General Population									Body 1.6 W/kg (mW/g) averaged over 1 gram											

**Table 11-24
WLAN Hotspot SAR**

MEASUREMENT RESULTS																		
FREQUENCY		Mode	Service	Bandwidth [MHz]	Maximum Allowed Power [dBm]	Conducted Power [dBm]	Power Drift [dB]	Spacing	Device Serial Number	Data Rate (Mbps)	Side	Duty Cycle (%)	Peak SAR of Area Scan	SAR (1g)	Scaling Factor (Power)	Scaling Factor (Duty Cycle)	Reported SAR (1g)	Plot #
MHz	Ch.												(W/kg)	(W/kg)			(W/kg)	
2437	6	802.11b	DSSS	22	16.0	15.99	0.05	10 mm	06723	1	back	99.6	0.155	0.118	1.002	1.004	0.118	A32
2437	6	802.11b	DSSS	22	16.0	15.99	-0.01	10 mm	06723	1	front	99.6	0.088	-	1.002	1.004	-	
2437	6	802.11b	DSSS	22	16.0	15.99	0.10	10 mm	06723	1	top	99.6	0.047	-	1.002	1.004	-	
2437	6	802.11b	DSSS	22	16.0	15.99	0.02	10 mm	06723	1	left	99.6	0.060	-	1.002	1.004	-	
ANSI / IEEE C95.1 1992 - SAFETY LIMIT Spatial Peak Uncontrolled Exposure/General Population									Body 1.6 W/kg (mW/g) averaged over 1 gram									

FCC ID: ZNFLS450		SAR EVALUATION REPORT		Reviewed by: Quality Manager
Document S/N: OY1604060711-R1.ZNF	Test Dates: 04/05/16 - 04/11/16	DUT Type: Portable Handset		Page 47 of 59



11.4 SAR Test Notes

General Notes:

1. The test data reported are the worst-case SAR values according to test procedures specified in IEEE 1528-2013, and FCC KDB Publication 447498 D01v06.
2. Batteries are fully charged at the beginning of the SAR measurements.
3. Liquid tissue depth was at least 15.0 cm for all frequencies.
4. The manufacturer has confirmed that the device(s) tested have the same physical, mechanical and thermal characteristics and are within operational tolerances expected for production units.
5. SAR results were scaled to the maximum allowed power to demonstrate compliance per FCC KDB Publication 447498 D01v06.
6. Device was tested using a fixed spacing for body-worn accessory testing. A separation distance of 10 mm was considered because the manufacturer has determined that there will be body-worn accessories available in the marketplace for users to support this separation distance.
7. Per FCC KDB Publication 648474 D04v01r03, body-worn SAR was evaluated without a headset connected to the device. Since the standalone reported body-worn SAR was ≤ 1.2 W/kg, no additional body-worn SAR evaluations using a headset cable were required.
8. Per FCC KDB 865664 D01v01r04, variability SAR tests were performed when the measured SAR results for a frequency band were greater than or equal to 0.8 W/kg. Repeated SAR measurements are highlighted in the tables above for clarity. Please see Section 13 for variability analysis.
9. During SAR Testing for the Wireless Router conditions per FCC KDB Publication 941225 D06v02r01, the actual Portable Hotspot operation (with actual simultaneous transmission of a transmitter with WIFI) was not activated (See Section 6.7 for more details).

GSM Test Notes:

1. Body-Worn accessory testing is typically associated with voice operations. Therefore, GSM voice was evaluated for body-worn SAR.
2. Justification for reduced test configurations per KDB Publication 941225 D01v03r01 and October 2013 TCB Workshop Notes: The source-based frame-averaged output power was evaluated for all GPRS/EDGE slot configurations. The configuration with the highest target frame averaged output power was evaluated for hotspot SAR. When the maximum frame-averaged powers are equivalent across two or more slots (within 0.25 dB), the configuration with the most number of time slots was tested.
3. Per FCC KDB Publication 447498 D01v06, if the reported (scaled) SAR measured at the middle channel or highest output power channel for each test configuration is ≤ 0.8 W/kg then testing at the other channels is not required for such test configuration(s). When the maximum output power variation across the required test channels is $> \frac{1}{2}$ dB, instead of the middle channel, the highest output power channel was used.
4. GPRS was additionally evaluated for head and body-worn exposure conditions to address possible VoIP scenarios.

FCC ID: ZNFLS450	 PCTEST PROFESSIONAL LABORATORY, INC.	SAR EVALUATION REPORT		Reviewed by: Quality Manager
Document S/N: OY1604060711-R1.ZNF	Test Dates: 04/05/16 - 04/11/16	DUT Type: Portable Handset	Page 48 of 59	

CDMA Notes:



1. Head SAR for CDMA2000 mode was tested under RC3/SO55 per FCC KDB Publication 941225 D01v03r01.
2. Body-Worn SAR was tested with 1x RTT with TDSO / SO32 FCH Only. EVDO Rev0 and RevA and TDSO / SO32 FCH+SCH SAR tests were not required per the 3G SAR Test Reduction Procedure in FCC KDB Publication 941225 D01v03r01.
3. CDMA Wireless Router SAR is measured using Subtype 0/1 Physical Layer configurations for Rev. 0 according to KDB 941225 D01v03r01 procedures for data devices. Wireless Router SAR tests for Subtype 2 of Rev.A and 1x RTT configurations were not required per the 3G SAR Test Reduction Policy in KDB Publication 941225 D01v03r01.
4. Head SAR was additionally evaluated using EVDO Rev. A to determine compliance for VoIP operations.
5. Per FCC KDB Publication 447498 D01v06, if the reported (scaled) SAR measured at the middle channel or highest output power channel for each test configuration is ≤ 0.8 W/kg then testing at the other channels is not required for such test configuration(s). When the maximum output power variation across the required test channels is $> \frac{1}{2}$ dB, instead of the middle channel, the highest output power channel was used.

UMTS Notes:

1. UMTS mode in was tested under RMC 12.2 kbps with HSPA Inactive per KDB Publication 941225 D01v03r01. AMR and HSPA SAR was not required per the 3G Test Reduction Procedure in KDB Publication 941225 D01v03r01.
2. Per FCC KDB Publication 447498 D01v06, if the reported (scaled) SAR measured at the middle channel or highest output power channel for each test configuration is ≤ 0.8 W/kg then testing at the other channels is not required for such test configuration(s). When the maximum output power variation across the required test channels is $> \frac{1}{2}$ dB, instead of the middle channel, the highest output power channel was used.



LTE Notes:

1. LTE Considerations: LTE test configurations are determined according to SAR Evaluation Considerations for LTE Devices in FCC KDB Publication 941225 D05v02r04. The general test procedures used for testing can be found in Section 8.6.4.
2. MPR is permanently implemented for this device by the manufacturer. The specific manufacturer target MPR is indicated alongside the SAR results. MPR is enabled for this device, according to 3GPP TS36.101 Section 6.2.3 – 6.2.5 under Table 6.2.3-1.
3. A-MPR was disabled for all SAR tests by setting NS=01 on the base station simulator. SAR tests were performed with the same number of RB and RB offsets transmitting on all TTI frames (maximum TTI).
4. Per FCC KDB Publication 447498 D01v06, when the reported (scaled) for LTE Band 41 SAR measured at the highest output power channel in a given a test configuration was > 0.6 W/kg, testing at the other channels was required for such test configurations.
5. TDD LTE was tested using UL-DL configuration 0 with 6 UL subframes and 2 S subframes using normal cyclic prefix only and special subframe configuration 6. Due to equipment setup issues with extended cyclic prefix as a result of test samples configured for normal cyclic prefix, SAR tests were performed at maximum output power and worst-case transmission duty factor in normal cyclic prefix. Results were then scaled to the duty factor required for extended cyclic prefix listed in 3GPP TS 36.211 Section 4. The cyclic prefix scaling factor for LTE Band 41 was calculated by dividing the extended cyclic prefix duty factor by the normal cyclic prefix duty factor. Per 3GPP 36.211 Section 4, the duty factor for special subframe configuration 6 using normal cyclic prefix is 0.629. The duty factor for special subframe configuration 6 using extended cyclic prefix is 0.633.

FCC ID: ZNFLS450	 PCTEST PROFESSIONAL LABORATORY, INC.	SAR EVALUATION REPORT		Reviewed by: Quality Manager
Document S/N: OY1604060711-R1.ZNF	Test Dates: 04/05/16 - 04/11/16	DUT Type: Portable Handset		Page 49 of 59

WLAN Notes:

1. For held-to-ear and hotspot operations, the initial test position procedures were applied. The test position with the highest extrapolated peak SAR will be used as the initial test position. When reported SAR for the initial test position is ≤ 0.4 W/kg, no additional testing for the remaining test positions was required. Otherwise, SAR is evaluated at the subsequent highest peak SAR positions until the reported SAR result is ≤ 0.8 W/kg or all test positions are measured.
2. Justification for test configurations for WLAN per KDB Publication 248227 D01v02r02 for 2.4 GHz WIFI operations, the highest measured maximum output power channel for DSSS was selected for SAR measurement. SAR for OFDM modes (2.4 GHz 802.11g/n) was not required due to the maximum allowed powers and the highest reported DSSS SAR. See Section 8.7.3 for more information. When the maximum reported 1g averaged SAR is ≤ 0.8 W/kg, SAR testing on additional channels was not required. Otherwise, SAR for the next highest output power channel was required until the reported SAR result was ≤ 1.20 W/kg or all test channels were measured.
3. The device was configured to transmit continuously at the required data rate, channel bandwidth and signal modulation, using the highest transmission duty factor supported by the test mode tools. The reported SAR was scaled to the 100% transmission duty factor to determine compliance. Procedures used to measure the duty factor are identical to that in the associated EMC test reports.

FCC ID: ZNFLS450	 SAR EVALUATION REPORT 		Reviewed by: Quality Manager
Document S/N: 0Y1604060711-R1.ZNF	Test Dates: 04/05/16 - 04/11/16	DUT Type: Portable Handset	Page 50 of 59

12 FCC MULTI-TX AND ANTENNA SAR CONSIDERATIONS

12.1 Introduction

The following procedures adopted from FCC KDB Publication 447498 D01v06 are applicable to devices with built-in unlicensed transmitters such as 802.11 and Bluetooth devices which may simultaneously transmit with the licensed transmitter.

12.2 Simultaneous Transmission Procedures

This device contains transmitters that may operate simultaneously. Therefore simultaneous transmission analysis is required. Per FCC KDB Publication 447498 D01v06 4.3.2 and IEEE 1528-2013 Section 6.3.4.1.2, simultaneous transmission SAR test exclusion may be applied when the sum of the 1-g SAR for all the simultaneous transmitting antennas in a specific a physical test configuration is ≤ 1.6 W/kg. The different test positions in an exposure condition may be considered collectively to determine SAR test exclusion according to the sum of 1-g SAR.



When standalone SAR is not required to be measured, per FCC KDB 447498 D01v06 4.3.2 b), the following equation must be used to estimate the standalone 1g SAR for simultaneous transmission assessment involving that transmitter.

$$\text{Estimated SAR} = \frac{\sqrt{f(\text{GHz})}}{7.5} * \frac{(\text{Max Power of channel, mW})}{\text{Min. Separation Distance, mm}}$$

**Table 12-1
Estimated SAR**

Mode	Frequency	Maximum Allowed Power	Separation Distance (Body)	Estimated SAR (Body)
	[MHz]	[dBm]	[mm]	[W/kg]
Bluetooth	2480	9.00	10	0.168

Note: Held-to ear configurations are not applicable to Bluetooth operations and therefore were not considered for simultaneous transmission. Per KDB Publication 447498 D01v06, the maximum power of the channel was rounded to the nearest mW before calculation.

FCC ID: ZNFLS450	 PCTEST ENGINEERING LABORATORY, INC.	SAR EVALUATION REPORT			Reviewed by: Quality Manager
Document S/N: 0Y1604060711-R1.ZNF	Test Dates: 04/05/16 - 04/11/16	DUT Type: Portable Handset		Page 51 of 59	

12.3 Head SAR Simultaneous Transmission Analysis

Table 12-2
Simultaneous Transmission Scenario with 2.4 GHz WLAN (Held to Ear)

Exposure Condition	Mode	2G/3G/4G SAR (W/kg)	2.4 GHz WLAN SAR (W/kg)	Σ SAR (W/kg)
Head SAR	CDMA/EVDO BC10 (§90S)	0.502	0.613	1.115
	CDMA/EVDO BC0 (§22H)	0.597	0.613	1.210
	PCS CDMA/EVDO	0.730	0.613	1.343
	GSM/GPRS 850	0.657	0.613	1.270
	GSM/GPRS 1900	0.352	0.613	0.965
	UMTS 850	0.419	0.613	1.032
	UMTS 1750	0.467	0.613	1.080
	UMTS 1900	0.568	0.613	1.181
	LTE Band 12	0.245	0.613	0.858
	LTE Band 26 (Cell)	0.425	0.613	1.038
	LTE Band 4 (AWS)	0.408	0.613	1.021
	LTE Band 25 (PCS)	0.507	0.613	1.120
	LTE Band 41	0.437	0.613	1.050

12.4 Body-Worn Simultaneous Transmission Analysis

Table 12-3
Simultaneous Transmission Scenario with 2.4 GHz WLAN (Body-Worn at 1.0 cm)

Exposure Condition	Mode	2G/3G/4G SAR (W/kg)	2.4 GHz WLAN SAR (W/kg)	Σ SAR (W/kg)
Body-Worn	CDMA BC10 (§90S)	0.950	0.118	1.068
	CDMA BC0 (§22H)	0.917	0.118	1.035
	PCS CDMA	0.894	0.118	1.012
	GSM/GPRS 850	0.981	0.118	1.099
	GSM/GPRS 1900	0.394	0.118	0.512
	UMTS 850	0.591	0.118	0.709
	UMTS 1750	1.012	0.118	1.130
	UMTS 1900	0.799	0.118	0.917
	LTE Band 12	0.456	0.118	0.574
	LTE Band 26 (Cell)	0.707	0.118	0.825
	LTE Band 4 (AWS)	0.977	0.118	1.095
	LTE Band 25 (PCS)	0.593	0.118	0.711
	LTE Band 41	0.382	0.118	0.500



FCC ID: ZNFLS450	 SAR EVALUATION REPORT 		Reviewed by: Quality Manager
Document S/N: OY1604060711-R1.ZNF	Test Dates: 04/05/16 - 04/11/16	DUT Type: Portable Handset	Page 52 of 59

Table 12-4
Simultaneous Transmission Scenario with Bluetooth (Body-Worn at 1.0 cm)

Exposure Condition	Mode	2G/3G/4G SAR (W/kg)	Bluetooth SAR (W/kg)	Σ SAR (W/kg)
Body-Worn	CDMA BC10 (§90S)	0.950	0.168	1.118
	CDMA BC0 (§22H)	0.917	0.168	1.085
	PCS CDMA	0.894	0.168	1.062
	GSM/GPRS 850	0.981	0.168	1.149
	GSM/GPRS 1900	0.394	0.168	0.562
	UMTS 850	0.591	0.168	0.759
	UMTS 1750	1.012	0.168	1.180
	UMTS 1900	0.799	0.168	0.967
	LTE Band 12	0.456	0.168	0.624
	LTE Band 26 (Cell)	0.707	0.168	0.875
	LTE Band 4 (AWS)	0.977	0.168	1.145
	LTE Band 25 (PCS)	0.593	0.168	0.761
	LTE Band 41	0.382	0.168	0.550

Note: Bluetooth SAR was not required to be measured per FCC KDB 447498. Estimated SAR results were used in the above table to determine simultaneous transmission SAR test exclusion.



12.5 Hotspot SAR Simultaneous Transmission Analysis

Table 12-5
Simultaneous Transmission Scenario (2.4 GHz Hotspot at 1.0 cm)

Exposure Condition	Mode	2G/3G/4G SAR (W/kg)	2.4 GHz WLAN SAR (W/kg)	Σ SAR (W/kg)
Hotspot SAR	EVDO BC10 (§90S)	0.969	0.118	1.087
	EVDO BC0 (§22H)	0.923	0.118	1.041
	PCS EVDO	0.898	0.118	1.016
	GPRS 850	0.981	0.118	1.099
	GPRS 1900	0.393	0.118	0.511
	UMTS 850	0.591	0.118	0.709
	UMTS 1750	1.012	0.118	1.130
	UMTS 1900	0.799	0.118	0.917
	LTE Band 12	0.456	0.118	0.574
	LTE Band 26 (Cell)	0.707	0.118	0.825
	LTE Band 4 (AWS)	0.977	0.118	1.095
	LTE Band 25 (PCS)	0.593	0.118	0.711
	LTE Band 41	0.382	0.118	0.500

12.6 Simultaneous Transmission Conclusion

The above numerical summed SAR results for all the worst-case simultaneous transmission conditions were below the SAR limit. Therefore, the above analysis is sufficient to determine that simultaneous transmission cases will not exceed the SAR limit and therefore no measured volumetric simultaneous SAR summation is required per FCC KDB Publication 447498 D01v06 and IEEE 1528-2013 Section 6.3.4.1.2.

FCC ID: ZNFLS450		SAR EVALUATION REPORT		Reviewed by: Quality Manager
Document S/N: OY1604060711-R1.ZNF	Test Dates: 04/05/16 - 04/11/16	DUT Type: Portable Handset		Page 53 of 59

13 SAR MEASUREMENT VARIABILITY

13.1 Measurement Variability

Per FCC KDB Publication 865664 D01v01r04, SAR measurement variability was assessed for each frequency band, which was determined by the SAR probe calibration point and tissue-equivalent medium used for the device measurements. When both head and body tissue-equivalent media were required for SAR measurements in a frequency band, the variability measurement procedures were applied to the tissue medium with the highest measured SAR, using the highest measured SAR configuration for that tissue-equivalent medium. These additional measurements were repeated after the completion of all measurements requiring the same head or body tissue-equivalent medium in a frequency band. The test device was returned to ambient conditions (normal room temperature) with the battery fully charged before it was re-mounted on the device holder for the repeated measurement(s) to minimize any unexpected variations in the repeated results.

SAR Measurement Variability was assessed using the following procedures for each frequency band:



- 1) When the original highest measured SAR is ≥ 0.80 W/kg, the measurement was repeated once.
- 2) A second repeated measurement was performed only if the ratio of largest to smallest SAR for the original and first repeated measurements was > 1.20 or when the original or repeated measurement was ≥ 1.45 W/kg (~ 10% from the 1-g SAR limit).
- 3) A third repeated measurement was performed only if the original, first or second repeated measurement was ≥ 1.5 W/kg and the ratio of largest to smallest SAR for the original, first and second repeated measurements is > 1.20 .
- 4) Repeated measurements are not required when the original highest measured SAR is < 0.80 W/kg

**Table 13-1
Body SAR Measurement Variability Results**

BODY VARIABILITY RESULTS												
Band	FREQUENCY		Mode	Service	Side	Spacing	Measured SAR (1g)	1st Repeated SAR (1g)	Ratio	2nd Repeated SAR (1g)	Ratio	3rd Repeated SAR (1g)
	MHz	Ch.					(W/kg)	(W/kg)		(W/kg)		(W/kg)
835	820.10	564	CDMA BC10 (§90S)	TDSO / SO32	back	10 mm	0.929	0.900	1.03	N/A	N/A	N/A
1750	1732.40	1412	UMTS 1750	RMC	back	10 mm	0.986	0.909	1.08	N/A	N/A	N/A
ANSI / IEEE C95.1 1992 - SAFETY LIMIT Spatial Peak Uncontrolled Exposure/General Population						Body 1.6 W/kg (mW/g) averaged over 1 gram						

13.2 Measurement Uncertainty



The measured SAR was < 1.5 W/kg for all frequency bands. Therefore, per KDB Publication 865664 D01v01r04, the extended measurement uncertainty analysis per IEEE 1528-2013 was not required.

FCC ID: ZNFLS450		SAR EVALUATION REPORT		Reviewed by: Quality Manager
Document S/N: OY1604060711-R1.ZNF	Test Dates: 04/05/16 - 04/11/16	DUT Type: Portable Handset		Page 54 of 59

14 EQUIPMENT LIST



Manufacturer	Model	Description	Cal Date	Cal Interval	Cal Due	Serial Number
Agilent	8753E	(30kHz-6GHz) Network Analyzer	3/2/2016	Annual	3/2/2017	JP38020182
Agilent	8753ES	S-Parameter Network Analyzer	11/4/2015	Annual	11/4/2016	US39170118
Agilent	E4432B	ESG-D Series Signal Generator	3/5/2016	Annual	3/5/2017	US40053896
Agilent	E4438C	ESG Vector Signal Generator	2/27/2016	Annual	2/27/2017	MY45091346
Agilent	E5515C	Wireless Communications Test Set	11/30/2015	Annual	11/30/2016	GB42361078
Agilent	N5182A	MXG Vector Signal Generator	11/6/2015	Annual	11/6/2016	MY47420603
Amplifier Research	1551G6	Amplifier	CBT	N/A	CBT	433971
Amplifier Research	1551G6	Amplifier	CBT	N/A	CBT	433972
Anritsu	MA24106A	USB Power Sensor	5/29/2015	Annual	5/29/2016	1231535
Anritsu	MA24106A	USB Power Sensor	5/29/2015	Annual	5/29/2016	1231538
Anritsu	MA24106A	USB Power Sensor	5/29/2015	Annual	5/29/2016	1244512
Anritsu	MA24106A	USB Power Sensor	5/29/2015	Annual	5/29/2016	1244515
Anritsu	MA2411B	Pulse Power Sensor	12/7/2015	Annual	12/7/2016	1207364
Anritsu	MA2411B	Pulse Power Sensor	2/28/2016	Annual	2/28/2017	1207470
Anritsu	MA2411B	Pulse Power Sensor	12/7/2015	Annual	12/7/2016	1339018
Anritsu	ML2495A	Power Meter	10/16/2015	Biennial	10/16/2017	941001
Anritsu	ML2495A	Power Meter	10/16/2015	Biennial	10/16/2017	1039008
Anritsu	ML2496A	Power Meter	2/28/2016	Annual	2/28/2017	1306009
Anritsu	MT8820C	Radio Communication Analyzer	7/24/2015	Annual	7/24/2016	6200901190
Anritsu	MT8820C	Radio Communication Analyzer	11/12/2015	Annual	11/12/2016	620144418
COMTECH	AR85729-5	Solid State Amplifier	CBT	N/A	CBT	M155A00-009
COMTECH	AR85729-5/5759B	Solid State Amplifier	CBT	N/A	CBT	M3W1A00-1002
Control Company	4040	Digital Thermometer	3/18/2015	Biennial	3/18/2017	150194895
Control Company	4353	Long Stem Thermometer	1/22/2015	Biennial	1/22/2017	150053029
Keysight	772D	Dual Directional Coupler	CBT	N/A	CBT	MY52180215
MCL	BW-N6W5+	6dB Attenuator	CBT	N/A	CBT	1139
MiniCircuits	SLP-2400+	Low Pass Filter	CBT	N/A	CBT	R8979500903
Mini-Circuits	BW-N20W5	Power Attenuator	CBT	N/A	CBT	1226
Mini-Circuits	BW-N20W5+	DC to 18 GHz Precision Fixed 20 dB Attenuator	CBT	N/A	CBT	N/A
Mini-Circuits	NLP-1200+	Low Pass Filter DC to 1000 MHz	CBT	N/A	CBT	N/A
Mini-Circuits	NLP-2950+	Low Pass Filter DC to 2700 MHz	CBT	N/A	CBT	N/A
Mitutoyo	CD-6-CSX	Digital Caliper	5/8/2014	Biennial	5/8/2016	13264162
Narda	4014C-6	4 - 8 GHz SMA 6 dB Directional Coupler	CBT	N/A	CBT	N/A
Narda	4772-3	Attenuator (3dB)	CBT	N/A	CBT	9406
Narda	BW-53W2	Attenuator (3dB)	CBT	N/A	CBT	120
Pasternack	NC-100	Torque Wrench	11/6/2015	Biennial	11/6/2017	N/A
Pasternack	NC-100	Torque Wrench	11/6/2015	Biennial	11/6/2017	N/A
Pasternack	PE2208-6	Bidirectional Coupler	CBT	N/A	CBT	N/A
Pasternack	PE2209-10	Bidirectional Coupler	CBT	N/A	CBT	N/A
Rohde & Schwarz	CMU200	Base Station Simulator	6/3/2015	Annual	6/3/2016	109892
Rohde & Schwarz	CMW500	Radio Communication Tester	10/13/2015	Annual	10/13/2016	100976
Seekonk	NC-100	Torque Wrench	11/6/2015	Biennial	11/6/2017	22313
SPEAG	D1750V2	1750 MHz SAR Dipole	4/15/2015	Annual	4/15/2016	1051
SPEAG	D1765V2	1765 MHz SAR Dipole	5/13/2015	Annual	5/13/2016	1008
SPEAG	D1900V2	1900 MHz SAR Dipole	2/19/2016	Annual	2/19/2017	5d148
SPEAG	D1900V2	1900 MHz SAR Dipole	7/14/2015	Annual	7/14/2016	5d149
SPEAG	D2450V2	2450 MHz SAR Dipole	2/18/2016	Annual	2/18/2017	882
SPEAG	D2600V2	2600 MHz SAR Dipole	10/21/2015	Annual	10/21/2016	1071
SPEAG	D750V3	750 MHz SAR Dipole	1/15/2016	Annual	1/15/2017	1003
SPEAG	D750V3	750 MHz SAR Dipole	3/16/2016	Annual	3/16/2017	1054
SPEAG	D835V2	835 MHz SAR Dipole	1/20/2016	Annual	1/20/2017	4d132
SPEAG	D835V2	835 MHz SAR Dipole	7/23/2015	Annual	7/23/2016	4d133
SPEAG	DAE4	Dasy Data Acquisition Electronics	2/19/2016	Annual	2/19/2017	665
SPEAG	DAE4	Dasy Data Acquisition Electronics	2/18/2016	Annual	2/18/2017	1272
SPEAG	DAE4	Dasy Data Acquisition Electronics	8/24/2015	Annual	8/24/2016	1322
SPEAG	DAE4	Dasy Data Acquisition Electronics	9/16/2015	Annual	9/16/2016	1323
SPEAG	DAE4	Dasy Data Acquisition Electronics	10/27/2015	Annual	10/27/2016	1333
SPEAG	DAE4	Dasy Data Acquisition Electronics	9/18/2015	Annual	9/18/2016	1364
SPEAG	DAE4	Dasy Data Acquisition Electronics	3/14/2016	Annual	3/14/2017	1368
SPEAG	DAE4	Dasy Data Acquisition Electronics	11/11/2015	Annual	11/11/2016	1415
SPEAG	DAE4	Dasy Data Acquisition Electronics	1/15/2016	Annual	1/15/2017	1466
SPEAG	DAK-3.5	Dielectric Assessment Kit	10/20/2015	Annual	10/20/2016	1091
SPEAG	DAKS VNA R140	VNA for Portable DAK	8/16/2015	Annual	8/16/2016	80513
SPEAG	DAKS-3.5	Portable Dielectric Assessment Kit	8/19/2015	Annual	8/19/2016	1041
SPEAG	ES3DV2	SAR Probe	8/26/2015	Annual	8/26/2016	3022
SPEAG	ES3DV3	SAR Probe	2/19/2016	Annual	2/19/2017	3213
SPEAG	ES3DV3	SAR Probe	9/18/2015	Annual	9/18/2016	3288
SPEAG	ES3DV3	SAR Probe	2/19/2016	Annual	2/19/2017	3318
SPEAG	ES3DV3	SAR Probe	3/18/2016	Annual	3/18/2017	3319
SPEAG	ES3DV3	SAR Probe	9/18/2015	Annual	9/18/2016	3332
SPEAG	ES3DV3	SAR Probe	10/29/2015	Annual	10/29/2016	3333
SPEAG	ES3DV3	SAR Probe	11/17/2015	Annual	11/17/2016	3334
SPEAG	ES3DV3	SAR Probe	6/22/2015	Annual	6/22/2016	3351

Note: CBT (Calibrated Before Testing). Prior to testing, the measurement paths containing a cable, amplifier, attenuator, coupler or filter were connected to a calibrated source (i.e. a signal generator) to determine the losses of the measurement path. The power meter offset was then adjusted to compensate for the measurement system losses. This level offset is stored within the power meter before measurements are made. This calibration verification procedure applies to the system verification and output power measurements. The calibrated reading is then taken directly from the power meter after compensation of the losses for all final power measurements.

FCC ID: ZNFLS450	 PCTEST ENGINEERING LABORATORY, INC.	SAR EVALUATION REPORT		Reviewed by: Quality Manager
Document S/N: OY1604060711-R1.ZNF	Test Dates: 04/05/16 - 04/11/16	DUT Type: Portable Handset		Page 55 of 59

15 MEASUREMENT UNCERTAINTIES

a	c	d	e= f(d,k)	f	g	h = c x f/e	i = c x g/e	k
Uncertainty Component	Tol. (± %)	Prob. Dist.	Div.	c _i 1gm	c _i 10 gms	1gm u _i (± %)	10gms u _i (± %)	v _i
Measurement System								
Probe Calibration	6.55	N	1	1.0	1.0	6.6	6.6	∞
Axial Isotropy	0.25	N	1	0.7	0.7	0.2	0.2	∞
Hemishperical Isotropy	1.3	N	1	0.7	0.7	0.9	0.9	∞
Boundary Effect	2.0	R	1.73	1.0	1.0	1.2	1.2	∞
Linearity	0.3	N	1	1.0	1.0	0.3	0.3	∞
System Detection Limits	0.25	R	1.73	1.0	1.0	0.1	0.1	∞
Readout Electronics	0.3	N	1	1.0	1.0	0.3	0.3	∞
Response Time	0.8	R	1.73	1.0	1.0	0.5	0.5	∞
Integration Time	2.6	R	1.73	1.0	1.0	1.5	1.5	∞
RF Ambient Conditions - Noise	3.0	R	1.73	1.0	1.0	1.7	1.7	∞
RF Ambient Conditions - Reflections	3.0	R	1.73	1.0	1.0	1.7	1.7	∞
Probe Positioner Mechanical Tolerance	0.4	R	1.73	1.0	1.0	0.2	0.2	∞
Probe Positioning w/ respect to Phantom	6.7	R	1.73	1.0	1.0	3.9	3.9	∞
Extrapolation, Interpolation & Integration algorithms for Max. SAR Evaluation	4.0	R	1.73	1.0	1.0	2.3	2.3	∞
Test Sample Related								
Test Sample Positioning	2.7	N	1	1.0	1.0	2.7	2.7	35
Device Holder Uncertainty	1.67	N	1	1.0	1.0	1.7	1.7	5
Output Power Variation - SAR drift measurement	5.0	R	1.73	1.0	1.0	2.9	2.9	∞
SAR Scaling	0.0	R	1.73	1.0	1.0	0.0	0.0	∞
Phantom & Tissue Parameters								
Phantom Uncertainty (Shape & Thickness tolerances)	7.6	R	1.73	1.0	1.0	4.4	4.4	∞
Liquid Conductivity - measurement uncertainty	4.2	N	1	0.78	0.71	3.3	3.0	10
Liquid Permittivity - measurement uncertainty	4.1	N	1	0.23	0.26	1.0	1.1	10
Liquid Conductivity - Temperature Uncertainty	3.4	R	1.73	0.78	0.71	1.5	1.4	∞
Liquid Permittivity - Temperature Uncertainty	0.6	R	1.73	0.23	0.26	0.1	0.1	∞
Liquid Conductivity - deviation from target values	5.0	R	1.73	0.64	0.43	1.8	1.2	∞
Liquid Permittivity - deviation from target values	5.0	R	1.73	0.60	0.49	1.7	1.4	∞
Combined Standard Uncertainty (k=1)	RSS					11.5	11.3	60
Expanded Uncertainty (95% CONFIDENCE LEVEL)	k=2					23.0	22.6	



FCC ID: ZNFLS450		SAR EVALUATION REPORT			Reviewed by: Quality Manager
Document S/N: OY1604060711-R1.ZNF	Test Dates: 04/05/16 - 04/11/16	DUT Type: Portable Handset			Page 56 of 59

16 CONCLUSION

16.1 Measurement Conclusion



The SAR evaluation indicates that the EUT complies with the RF radiation exposure limits of the FCC and Innovation, Science, and Economic Development Canada, with respect to all parameters subject to this test. These measurements were taken to simulate the RF effects of RF exposure under worst-case conditions. Precise laboratory measures were taken to assure repeatability of the tests. The results and statements relate only to the item(s) tested.

Please note that the absorption and distribution of electromagnetic energy in the body are very complex phenomena that depend on the mass, shape, and size of the body, the orientation of the body with respect to the field vectors, and the electrical properties of both the body and the environment. Other variables that may play a substantial role in possible biological effects are those that characterize the environment (e.g. ambient temperature, air velocity, relative humidity, and body insulation) and those that characterize the individual (e.g. age, gender, activity level, debilitation, or disease). Because various factors may interact with one another to vary the specific biological outcome of an exposure to electromagnetic fields, any protection guide should consider maximal amplification of biological effects as a result of field-body interactions, environmental conditions, and physiological variables. [3]



FCC ID: ZNFLS450	 PCTEST ENGINEERING LABORATORY, INC.	SAR EVALUATION REPORT		Reviewed by: Quality Manager
Document S/N: 0Y1604060711-R1.ZNF	Test Dates: 04/05/16 - 04/11/16	DUT Type: Portable Handset		Page 57 of 59

17 REFERENCES

- [1] Federal Communications Commission, ET Docket 93-62, Guidelines for Evaluating the Environmental Effects of Radiofrequency Radiation, Aug. 1996.
- [2] ANSI/IEEE C95.1-2005, American National Standard safety levels with respect to human exposure to radio frequency electromagnetic fields, 3kHz to 300GHz, New York: IEEE, 2006.
- [3] ANSI/IEEE C95.1-1992, American National Standard safety levels with respect to human exposure to radio frequency electromagnetic fields, 3kHz to 300GHz, New York: IEEE, Sept. 1992.
- [4] ANSI/IEEE C95.3-2002, IEEE Recommended Practice for the Measurement of Potentially Hazardous Electromagnetic Fields - RF and Microwave, New York: IEEE, December 2002.
- [5] IEEE Standards Coordinating Committee 39 –Standards Coordinating Committee 34 – IEEE Std. 1528-2013, IEEE Recommended Practice for Determining the Peak Spatial-Average Specific Absorption Rate (SAR) in the Human Head from Wireless Communications Devices: Measurement Techniques.
- [6] NCRP, National Council on Radiation Protection and Measurements, Biological Effects and Exposure Criteria for RadioFrequency Electromagnetic Fields, NCRP Report No. 86, 1986. Reprinted Feb. 1995.
- [7] T. Schmid, O. Egger, N. Kuster, Automated E-field scanning system for dosimetric assessments, IEEE Transaction on Microwave Theory and Techniques, vol. 44, Jan. 1996, pp. 105-113.
- [8] K. Pokovic, T. Schmid, N. Kuster, Robust setup for precise calibration of E-field probes in tissue simulating liquids at mobile communications frequencies, ICECOM97, Oct. 1997, pp. 1 -124.
- [9] K. Pokovic, T. Schmid, and N. Kuster, E-field Probe with improved isotropy in brain simulating liquids, Proceedings of the ELMAR, Zadar, Croatia, June 23-25, 1996, pp. 172-175.
- [10] Schmid & Partner Engineering AG, Application Note: Data Storage and Evaluation, June 1998, p2.
- [11] V. Hombach, K. Meier, M. Burkhardt, E. Kuhn, N. Kuster, The Dependence of EM Energy Absorption upon Human Modeling at 900 MHz, IEEE Transaction on Microwave Theory and Techniques, vol. 44 no. 10, Oct. 1996, pp. 1865-1873.
- [12] N. Kuster and Q. Balzano, Energy absorption mechanism by biological bodies in the near field of dipole antennas above 300MHz, IEEE Transaction on Vehicular Technology, vol. 41, no. 1, Feb. 1992, pp. 17-23.
- [13] G. Hartsgrove, A. Kraszewski, A. Surowiec, Simulated Biological Materials for Electromagnetic Radiation Absorption Studies, University of Ottawa, Bioelectromagnetics, Canada: 1987, pp. 29-36.
- [14] Q. Balzano, O. Garay, T. Manning Jr., Electromagnetic Energy Exposure of Simulated Users of Portable Cellular Telephones, IEEE Transactions on Vehicular Technology, vol. 44, no.3, Aug. 1995.
- [15] W. Gander, Computermathematick, Birkhaeuser, Basel, 1992.
- [16] W.H. Press, S.A. Teukolsky, W.T. Vetterling, and B.P. Flannery, Numerical Recipes in C, The Art of Scientific Computing, Second edition, Cambridge University Press, 1992.
- [17] N. Kuster, R. Kastle, T. Schmid, Dosimetric evaluation of mobile communications equipment with known precision, IEEE Transaction on Communications, vol. E80-B, no. 5, May 1997, pp. 645-652.

FCC ID: ZNFLS450	 PCTEST PROFESSIONAL LABORATORY, INC.	SAR EVALUATION REPORT		Reviewed by: Quality Manager
Document S/N: OY1604060711-R1.ZNF	Test Dates: 04/05/16 - 04/11/16	DUT Type: Portable Handset	Page 58 of 59	

- [18] CENELEC CLC/SC111B, European Prestandard (prENV 50166-2), Human Exposure to Electromagnetic Fields High-frequency: 10kHz-300GHz, Jan. 1995.
- [19] Prof. Dr. Niels Kuster, ETH, Eidgenössische Technische Hochschule Zürich, Dosimetric Evaluation of the Cellular Phone.
- [20] IEC 62209-1, Human exposure to radio frequency fields from hand-held and body-mounted wireless communication devices - Human models, instrumentation, and procedures - Part 1: Procedure to determine the specific absorption rate (SAR) for hand-held devices used in close proximity to the ear (frequency range of 300 MHz to 3 GHz), Feb. 2005.
- [21] Innovation, Science, Economic Development Canada RSS-102 Radio Frequency Exposure Compliance of Radiocommunication Apparatus (All Frequency Bands) Issue 5, March 2015.
- [22] Health Canada Safety Code 6 Limits of Human Exposure to Radio Frequency Electromagnetic Fields in the Frequency Range from 3 kHz – 300 GHz, 2015
- [23] FCC SAR Test Procedures for 2G-3G Devices, Mobile Hotspot and UMPC Devices KDB Publications 941225, D01-D07
- [24] SAR Measurement Guidance for IEEE 802.11 Transmitters, KDB Publication 248227 D01
- [25] FCC SAR Considerations for Handsets with Multiple Transmitters and Antennas, KDB Publications 648474 D03-D04
- [26] FCC SAR Evaluation Considerations for Laptop, Notebook, Netbook and Tablet Computers, FCC KDB Publication 616217 D04
- [27] FCC SAR Measurement and Reporting Requirements for 100MHz – 6 GHz, KDB Publications 865664 D01-D02
- [28] FCC General RF Exposure Guidance and SAR Procedures for Dongles, KDB Publication 447498, D01-D02
- [29] Anexo à Resolução No. 533, de 10 de Setembro de 2009.
- [30] IEC 62209-2, Human exposure to radio frequency fields from hand-held and body-mounted wireless communication devices - Human models, instrumentation, and procedures - Part 2: Procedure to determine the specific absorption rate (SAR) for wireless communication devices used in close proximity to the human body (frequency range of 30 MHz to 6 GHz), Mar. 2010.

FCC ID: ZNFLS450	 PCTEST ENGINEERING LABORATORY, INC.	SAR EVALUATION REPORT		Reviewed by: Quality Manager
Document S/N: 0Y1604060711-R1.ZNF	Test Dates: 04/05/16 - 04/11/16	DUT Type: Portable Handset	Page 59 of 59	

APPENDIX A: SAR TEST DATA

PCTEST ENGINEERING LABORATORY, INC.

DUT: ZNFLS450; Type: Portable Handset; Serial: 06715

Communication System: UID 0, Cellular CDMA (0); Frequency: 820.1 MHz; Duty Cycle: 1:1
Medium: 835 Head Medium parameters used (interpolated):
 $f = 820.1 \text{ MHz}$; $\sigma = 0.9 \text{ S/m}$; $\epsilon_r = 42.562$; $\rho = 1000 \text{ kg/m}^3$
Phantom section: Right Section

Test Date: 04-07-2016; Ambient Temp: 24.0°C; Tissue Temp: 22.5°C

Probe: ES3DV2 - SN3022; ConvF(6.11, 6.11, 6.11); Calibrated: 8/26/2015;
Sensor-Surface: 3mm (Mechanical Surface Detection)
Electronics: DAE4 Sn1323; Calibrated: 9/16/2015
Phantom: SAM Right; Type: QD000P40CD; Serial: TP:7535
Measurement SW: DASY52, Version 52.8 (8); SEMCAD X Version 14.6.10 (7331)

Mode: Cell. CDMA, Rule Part 90S, Right Head, Cheek, Mid.ch

Area Scan (8x13x1): Measurement grid: dx=15mm, dy=15mm
Zoom Scan (5x5x7)/Cube 0: Measurement grid: dx=8mm, dy=8mm, dz=5mm
Reference Value = 23.69 V/m; Power Drift = -0.02 dB
Peak SAR (extrapolated) = 0.604 W/kg
SAR(1 g) = 0.469 W/kg

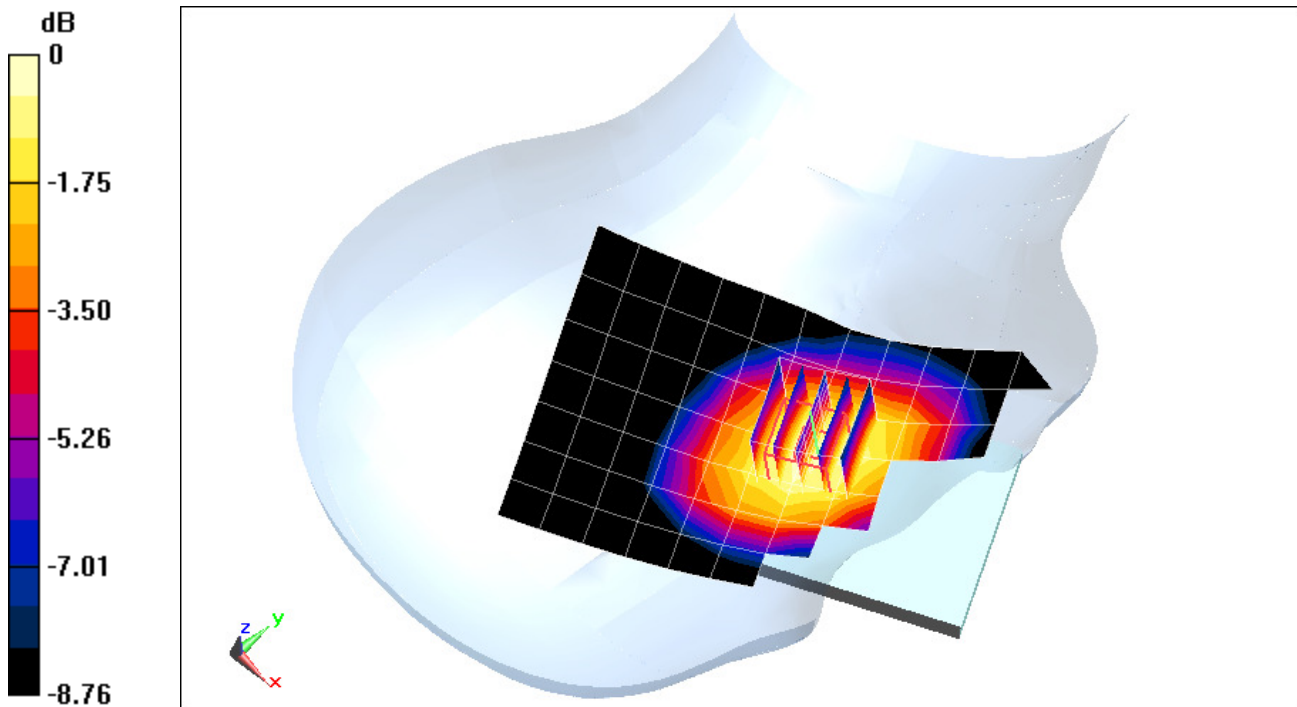

0 dB = 0.520 W/kg = -2.84 dBW/kg

PCTEST ENGINEERING LABORATORY, INC.

DUT: ZNFLS450; Type: Portable Handset; Serial: 06715

Communication System: UID 0, CDMA; Frequency: 836.52 MHz; Duty Cycle: 1:1
Medium: 835 Head Medium parameters used (interpolated):
 $f = 836.52 \text{ MHz}$; $\sigma = 0.915 \text{ S/m}$; $\epsilon_r = 42.375$; $\rho = 1000 \text{ kg/m}^3$
Phantom section: Right Section

Test Date: 04-07-2016; Ambient Temp: 24.0°C; Tissue Temp: 22.5°C

Probe: ES3DV2 - SN3022; ConvF(6.11, 6.11, 6.11); Calibrated: 8/26/2015;
Sensor-Surface: 3mm (Mechanical Surface Detection)
Electronics: DAE4 Sn1323; Calibrated: 9/16/2015
Phantom: SAM Right; Type: QD000P40CD; Serial: TP:7535
Measurement SW: DASYS2, Version 52.8 (8); SEMCAD X Version 14.6.10 (7331)

Mode: Cell. EVDO Rev. A, Rule Part 22H, Right Head, Cheek, Mid.ch

Area Scan (8x13x1): Measurement grid: $dx=15\text{mm}$, $dy=15\text{mm}$
Zoom Scan (5x5x7)/Cube 0: Measurement grid: $dx=8\text{mm}$, $dy=8\text{mm}$, $dz=5\text{mm}$
Reference Value = 25.96 V/m; Power Drift = 0.00 dB
Peak SAR (extrapolated) = 0.745 W/kg
SAR(1 g) = 0.584 W/kg

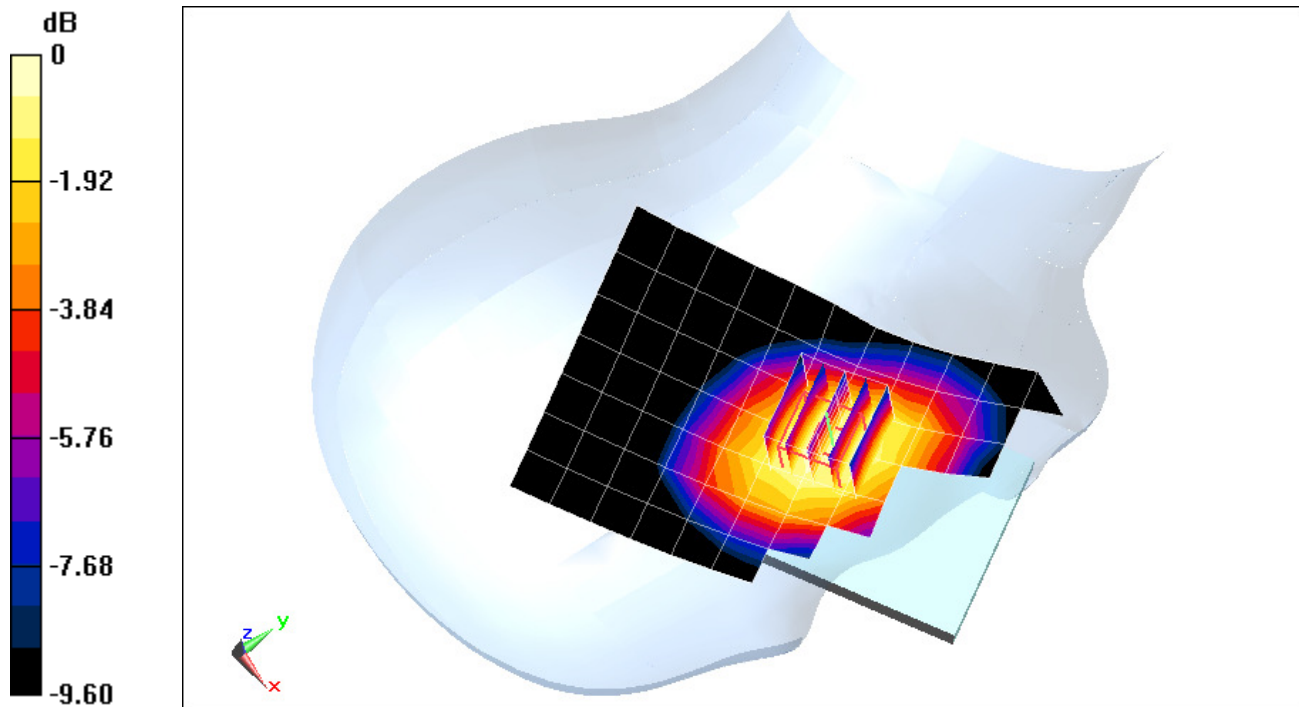

0 dB = 0.641 W/kg = -1.93 dBW/kg

PCTEST ENGINEERING LABORATORY, INC.

DUT: ZNFLS450; Type: Portable Handset; Serial: 06715

Communication System: UID 0, PCS CDMA (0); Frequency: 1880 MHz; Duty Cycle: 1:1
Medium: 1900 Head Medium parameters used:
 $f = 1880 \text{ MHz}$; $\sigma = 1.409 \text{ S/m}$; $\epsilon_r = 39.472$; $\rho = 1000 \text{ kg/m}^3$
Phantom section: Left Section

Test Date: 04-07-2016; Ambient Temp: 23.5°C; Tissue Temp: 22.5°C

Probe: ES3DV3 - SN3213; ConvF(5.05, 5.05, 5.05); Calibrated: 2/19/2016;
Sensor-Surface: 3mm (Mechanical Surface Detection)
Electronics: DAE4 Sn1272; Calibrated: 2/18/2016
Phantom: SAM v5.0 front; Type: QD000P40CD; Serial: TP-1646
Measurement SW: DASYS2, Version 52.8 (8); SEMCAD X Version 14.6.10 (7331)

Mode: PCS EVDO Rev A, Left Head, Cheek, Mid.ch

Area Scan (9x15x1): Measurement grid: $dx=15\text{mm}$, $dy=15\text{mm}$
Zoom Scan (5x5x7)/Cube 0: Measurement grid: $dx=8\text{mm}$, $dy=8\text{mm}$, $dz=5\text{mm}$
Reference Value = 21.60 V/m; Power Drift = -0.06 dB
Peak SAR (extrapolated) = 1.06 W/kg
SAR(1 g) = 0.652 W/kg

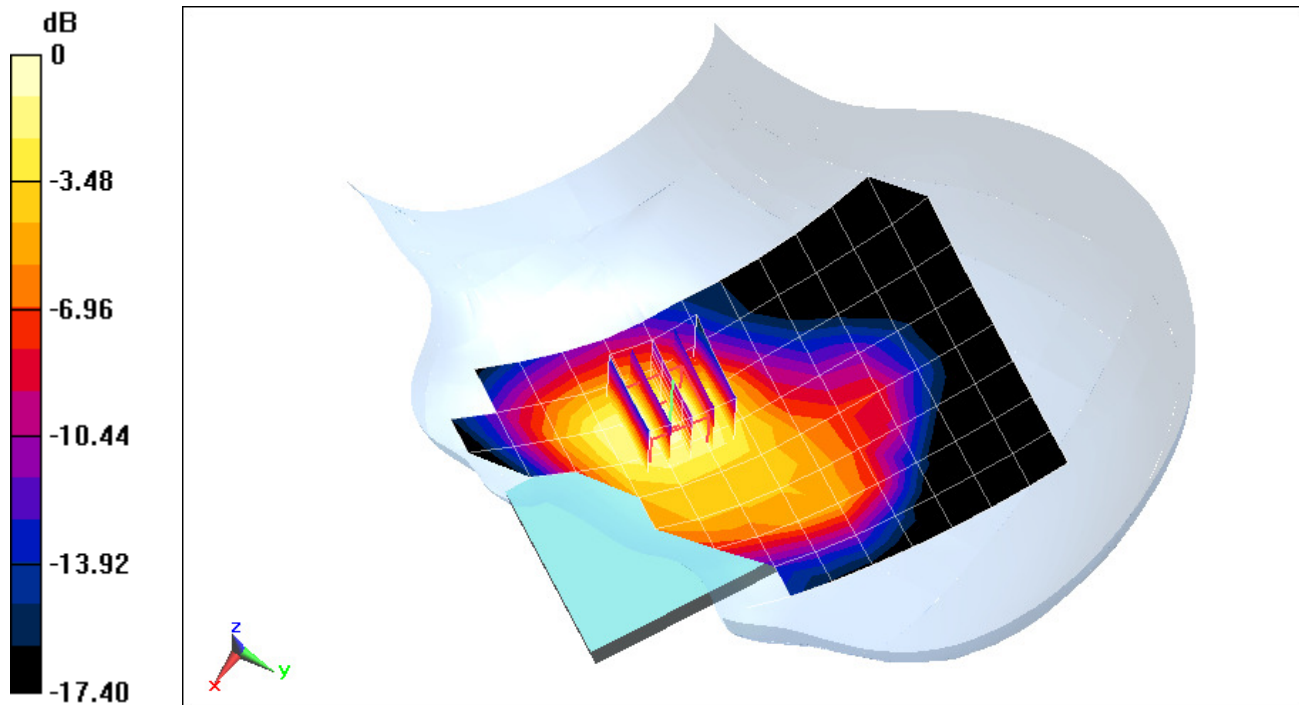

0 dB = 0.787 W/kg = -1.04 dBW/kg

PCTEST ENGINEERING LABORATORY, INC.

DUT: ZNFLS450; Type: Portable Handset; Serial: 06715

Communication System: UID 0, GSM GPRS; 2 Tx slots (0); Frequency: 836.6 MHz; Duty Cycle: 1:4.15
Medium: 835 Head Medium parameters used (interpolated):
 $f = 836.6 \text{ MHz}$; $\sigma = 0.915 \text{ S/m}$; $\epsilon_r = 42.374$; $\rho = 1000 \text{ kg/m}^3$
Phantom section: Right Section

Test Date: 04-07-2016; Ambient Temp: 24.0°C; Tissue Temp: 22.5°C

Probe: ES3DV2 - SN3022; ConvF(6.11, 6.11, 6.11); Calibrated: 8/26/2015;
Sensor-Surface: 3mm (Mechanical Surface Detection)
Electronics: DAE4 Sn1323; Calibrated: 9/16/2015
Phantom: SAM Right; Type: QD000P40CD; Serial: TP:7535
Measurement SW: DASY52, Version 52.8 (8); SEMCAD X Version 14.6.10 (7331)

Mode: GPRS 850, Right Head, Cheek, Mid.ch, 2 Tx slots

Area Scan (8x13x1): Measurement grid: dx=15mm, dy=15mm
Zoom Scan (5x5x7)/Cube 0: Measurement grid: dx=8mm, dy=8mm, dz=5mm
Reference Value = 25.68 V/m; Power Drift = 0.10 dB
Peak SAR (extrapolated) = 0.742 W/kg
SAR(1 g) = 0.575 W/kg

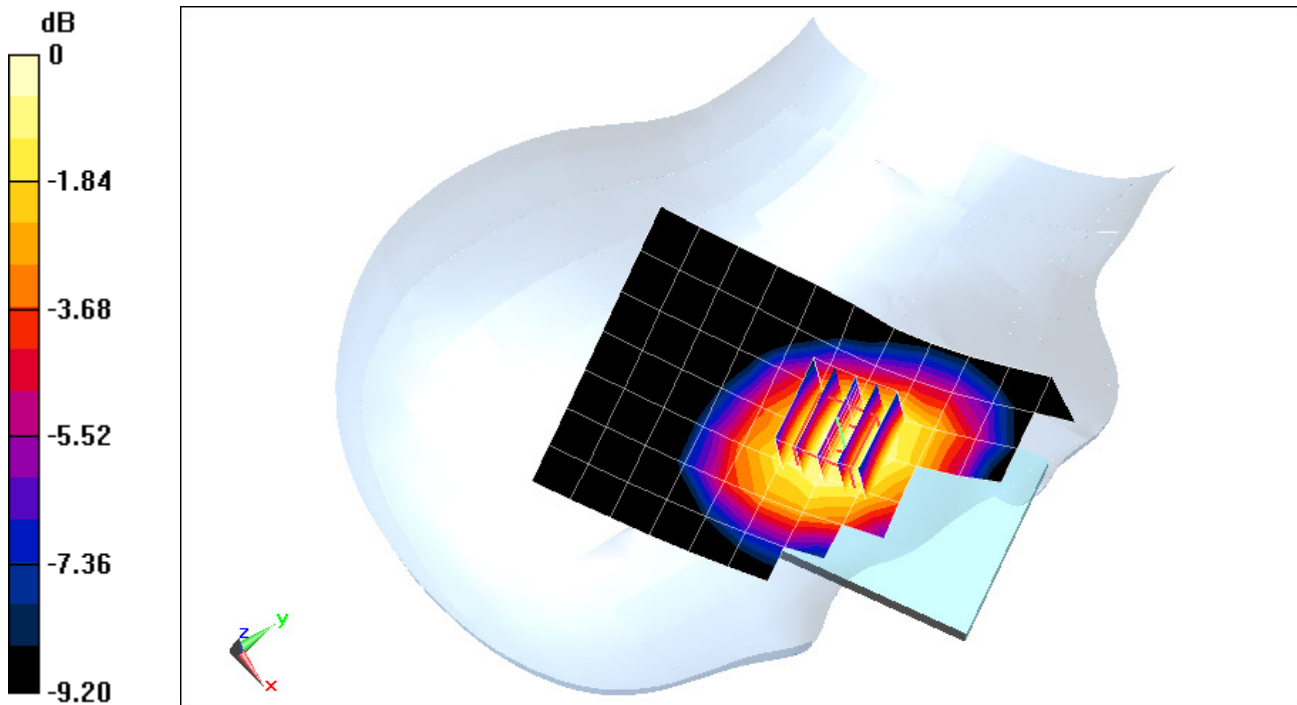

0 dB = 0.633 W/kg = -1.99 dBW/kg

PCTEST ENGINEERING LABORATORY, INC.

DUT: ZNFLS450; Type: Portable Handset; Serial: 06715

Communication System: UID 0, GSM; Frequency: 1880 MHz; Duty Cycle: 1:8.3
Medium: 1900 Head Medium parameters used:
 $f = 1880 \text{ MHz}$; $\sigma = 1.409 \text{ S/m}$; $\epsilon_r = 39.472$; $\rho = 1000 \text{ kg/m}^3$
Phantom section: Left Section

Test Date: 04-07-2016; Ambient Temp: 23.5°C; Tissue Temp: 22.5°C

Probe: ES3DV3 - SN3213; ConvF(5.05, 5.05, 5.05); Calibrated: 2/19/2016;
Sensor-Surface: 3mm (Mechanical Surface Detection)
Electronics: DAE4 Sn1272; Calibrated: 2/18/2016
Phantom: SAM v5.0 front; Type: QD000P40CD; Serial: TP-1646
Measurement SW: DASY52, Version 52.8 (8); SEMCAD X Version 14.6.10 (7331)

Mode: GSM 1900, Left Head, Cheek, Mid.ch

Area Scan (9x15x1): Measurement grid: dx=15mm, dy=15mm
Zoom Scan (5x5x7)/Cube 0: Measurement grid: dx=8mm, dy=8mm, dz=5mm
Reference Value = 15.17 V/m; Power Drift = -0.07 dB
Peak SAR (extrapolated) = 0.497 W/kg
SAR(1 g) = 0.309 W/kg

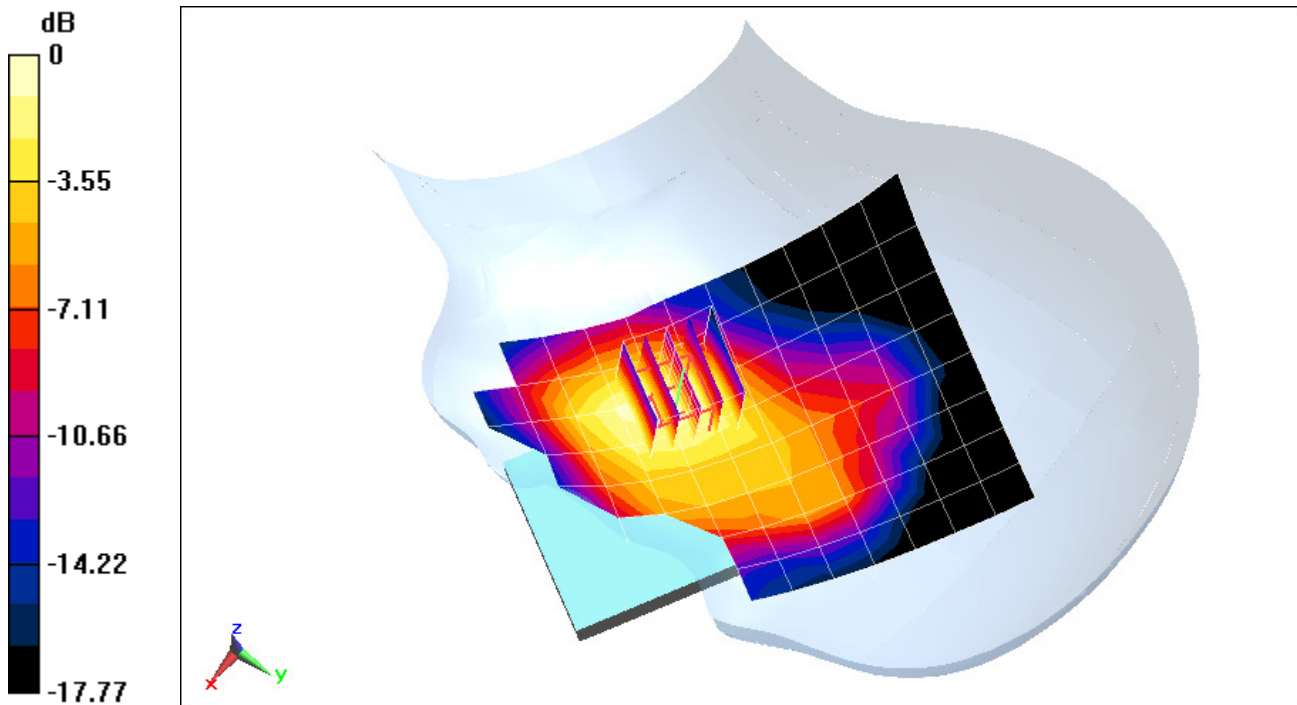

0 dB = 0.370 W/kg = -4.32 dBW/kg

PCTEST ENGINEERING LABORATORY, INC.

DUT: ZNFLS450; Type: Portable Handset; Serial: 06731

Communication System: UID 0, UMTS; Frequency: 836.6 MHz; Duty Cycle: 1:1
Medium: 835 Head Medium parameters used (interpolated):
 $f = 836.6 \text{ MHz}$; $\sigma = 0.915 \text{ S/m}$; $\epsilon_r = 42.374$; $\rho = 1000 \text{ kg/m}^3$
Phantom section: Right Section

Test Date: 04-07-2016; Ambient Temp: 24.0°C; Tissue Temp: 22.5°C

Probe: ES3DV2 - SN3022; ConvF(6.11, 6.11, 6.11); Calibrated: 8/26/2015;
Sensor-Surface: 3mm (Mechanical Surface Detection)
Electronics: DAE4 Sn1323; Calibrated: 9/16/2015
Phantom: SAM Right; Type: QD000P40CD; Serial: TP:7535
Measurement SW: DASY52, Version 52.8 (8); SEMCAD X Version 14.6.10 (7331)

Mode: UMTS 850, Right Head, Cheek, Mid.ch

Area Scan (9x15x1): Measurement grid: dx=15mm, dy=15mm
Zoom Scan (5x5x7)/Cube 0: Measurement grid: dx=8mm, dy=8mm, dz=5mm
Reference Value = 21.91 V/m; Power Drift = 0.00 dB
Peak SAR (extrapolated) = 0.532 W/kg
SAR(1 g) = 0.406 W/kg

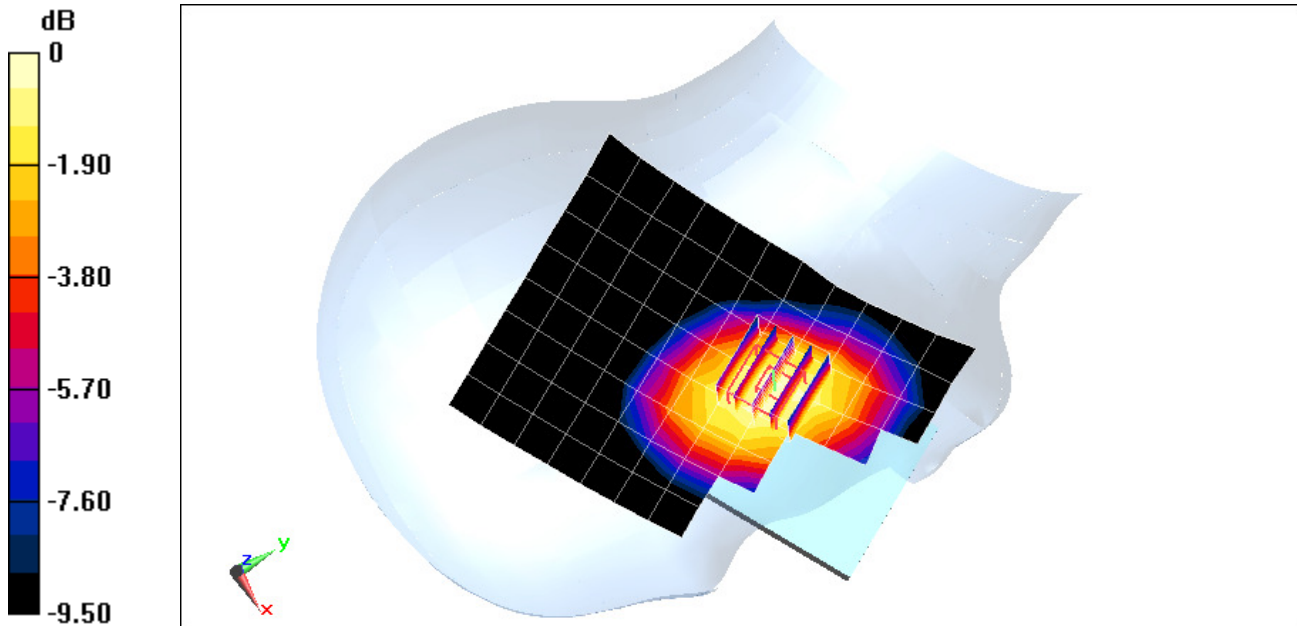

0 dB = 0.446 W/kg = -3.51 dBW/kg

PCTEST ENGINEERING LABORATORY, INC.

DUT: ZNFLS450; Type: Portable Handset; Serial: 06715

Communication System: UID 0, UMTS; Frequency: 1732.4 MHz; Duty Cycle: 1:1
Medium: 1750 Head Medium parameters used (interpolated):
 $f = 1732.4 \text{ MHz}$; $\sigma = 1.317 \text{ S/m}$; $\epsilon_r = 39.498$; $\rho = 1000 \text{ kg/m}^3$
Phantom section: Left Section

Test Date: 04-07-2016; Ambient Temp: 23.0°C; Tissue Temp: 23.2°C

Probe: ES3DV2 - SN3022; ConvF(5.08, 5.08, 5.08); Calibrated: 8/26/2015;
Sensor-Surface: 3mm (Mechanical Surface Detection)
Electronics: DAE4 Sn1323; Calibrated: 9/16/2015
Phantom: SAM Right; Type: QD000P40CD; Serial: TP:7535
Measurement SW: DASY52, Version 52.8 (8); SEMCAD X Version 14.6.10 (7331)

Mode: UMTS 1750, Left Head, Cheek, Mid.ch

Area Scan (8x13x1): Measurement grid: dx=15mm, dy=15mm
Zoom Scan (5x5x7)/Cube 0: Measurement grid: dx=8mm, dy=8mm, dz=5mm
Reference Value = 19.09 V/m; Power Drift = 0.02 dB
Peak SAR (extrapolated) = 0.690 W/kg
SAR(1 g) = 0.455 W/kg

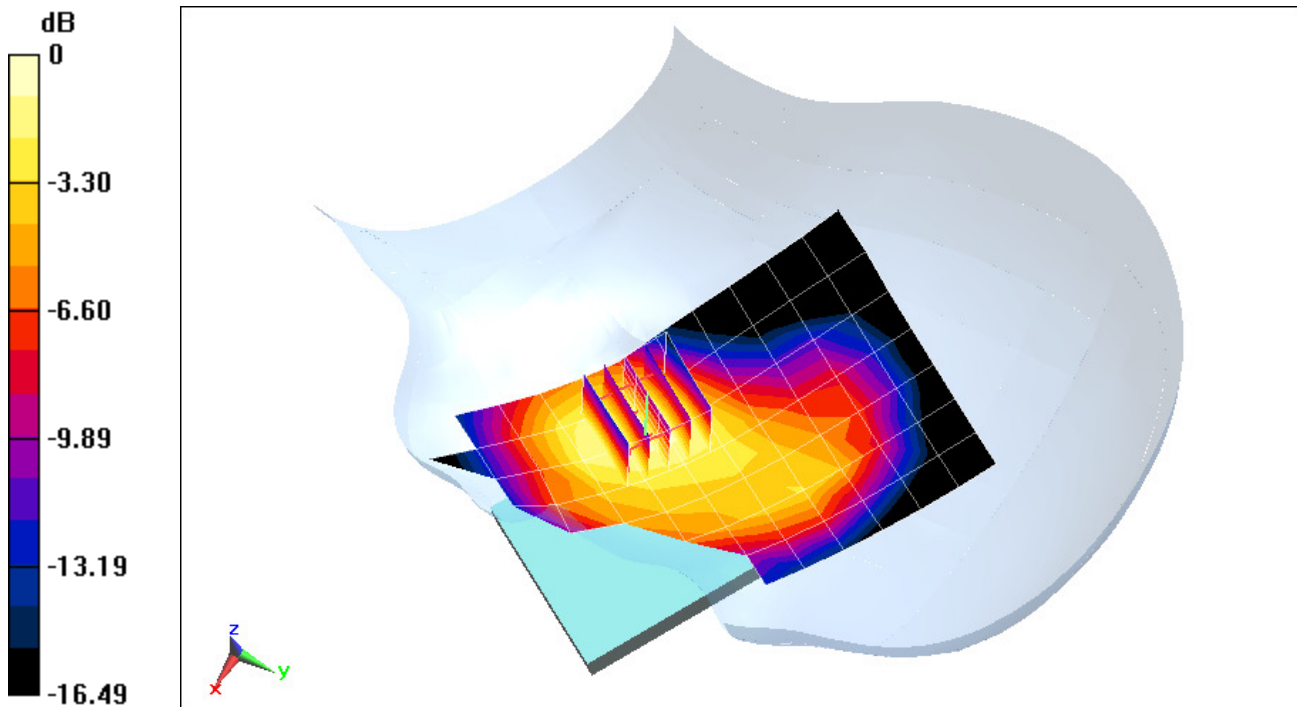

0 dB = 0.534 W/kg = -2.72 dBW/kg

PCTEST ENGINEERING LABORATORY, INC.

DUT: ZNFLS450; Type: Portable Handset; Serial: 06715

Communication System: UID 0, UMTS; Frequency: 1880 MHz; Duty Cycle: 1:1
Medium: 1900 Head Medium parameters used:
 $f = 1880 \text{ MHz}$; $\sigma = 1.409 \text{ S/m}$; $\epsilon_r = 39.472$; $\rho = 1000 \text{ kg/m}^3$
Phantom section: Left Section

Test Date: 04-07-2016; Ambient Temp: 23.5°C; Tissue Temp: 22.5°C

Probe: ES3DV3 - SN3213; ConvF(5.05, 5.05, 5.05); Calibrated: 2/19/2016;
Sensor-Surface: 3mm (Mechanical Surface Detection)
Electronics: DAE4 Sn1272; Calibrated: 2/18/2016
Phantom: SAM v5.0 front; Type: QD000P40CD; Serial: TP-1646
Measurement SW: DASY52, Version 52.8 (8); SEMCAD X Version 14.6.10 (7331)

Mode: UMTS 1900, Left Head, Cheek, Mid.ch

Area Scan (9x15x1): Measurement grid: dx=15mm, dy=15mm
Zoom Scan (5x5x7)/Cube 0: Measurement grid: dx=8mm, dy=8mm, dz=5mm
Reference Value = 20.08 V/m; Power Drift = -0.15 dB
Peak SAR (extrapolated) = 0.885 W/kg
SAR(1 g) = 0.550 W/kg

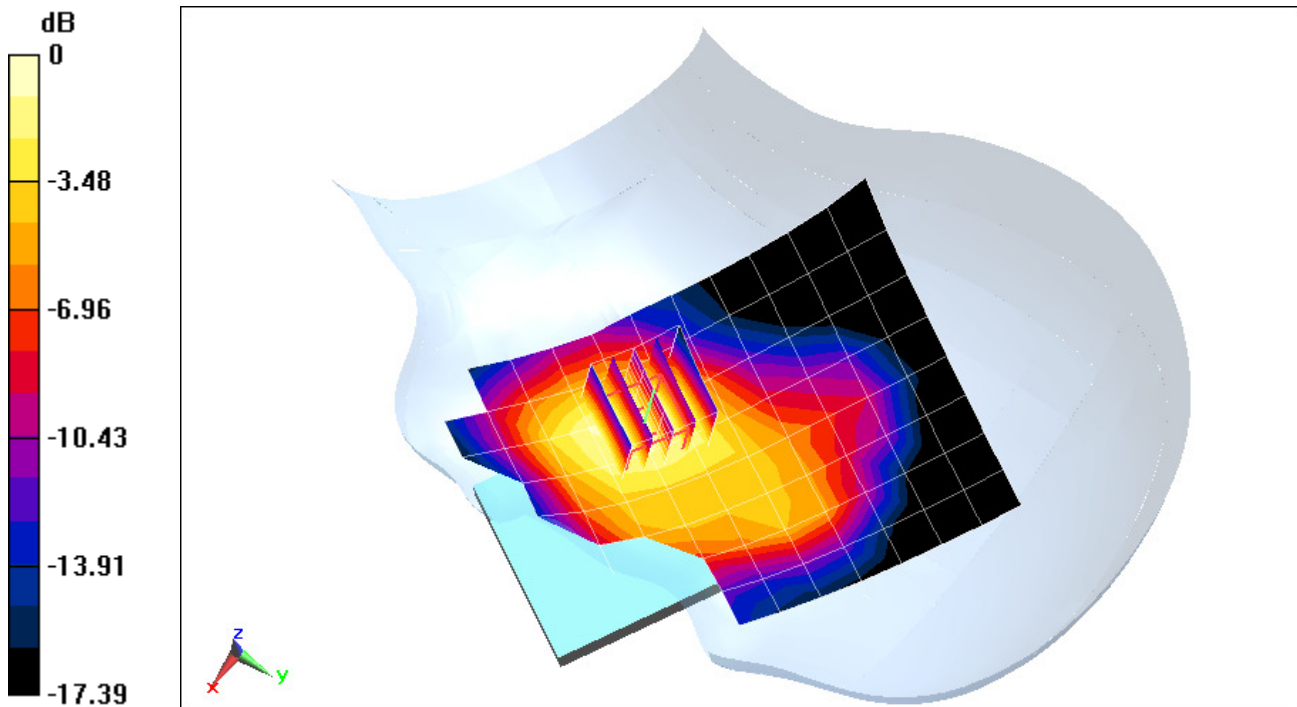

0 dB = 0.658 W/kg = -1.82 dBW/kg

PCTEST ENGINEERING LABORATORY, INC.

DUT: ZNFLS450; Type: Portable Handset; Serial: 06731

Communication System: UID 0, LTE Band 12; Frequency: 707.5 MHz; Duty Cycle: 1:1
Medium: 750 Head Medium parameters used (interpolated):
 $f = 707.5 \text{ MHz}$; $\sigma = 0.863 \text{ S/m}$; $\epsilon_r = 43.277$; $\rho = 1000 \text{ kg/m}^3$
Phantom section: Right Section

Test Date: 04-06-2016; Ambient Temp: 23.4°C; Tissue Temp: 23.0°C

Probe: ES3DV3 - SN3333; ConvF(6.46, 6.46, 6.46); Calibrated: 10/29/2015;
Sensor-Surface: 3mm (Mechanical Surface Detection)
Electronics: DAE4 Sn1333; Calibrated: 10/27/2015
Phantom: SAM Front; Type: QD000P40CD; Serial: TP:1758
Measurement SW: DASY52, Version 52.8 (8); SEMCAD X Version 14.6.10 (7331)

Mode: LTE Band 12, Right Head, Cheek, Mid.ch
10 MHz Bandwidth, QPSK, 1 RB, 25 RB Offset

Area Scan (8x13x1): Measurement grid: $dx=15\text{mm}$, $dy=15\text{mm}$
Zoom Scan (5x5x7)/Cube 0: Measurement grid: $dx=8\text{mm}$, $dy=8\text{mm}$, $dz=5\text{mm}$
Reference Value = 17.92 V/m; Power Drift = -0.03 dB
Peak SAR (extrapolated) = 0.297 W/kg
SAR(1 g) = 0.240 W/kg

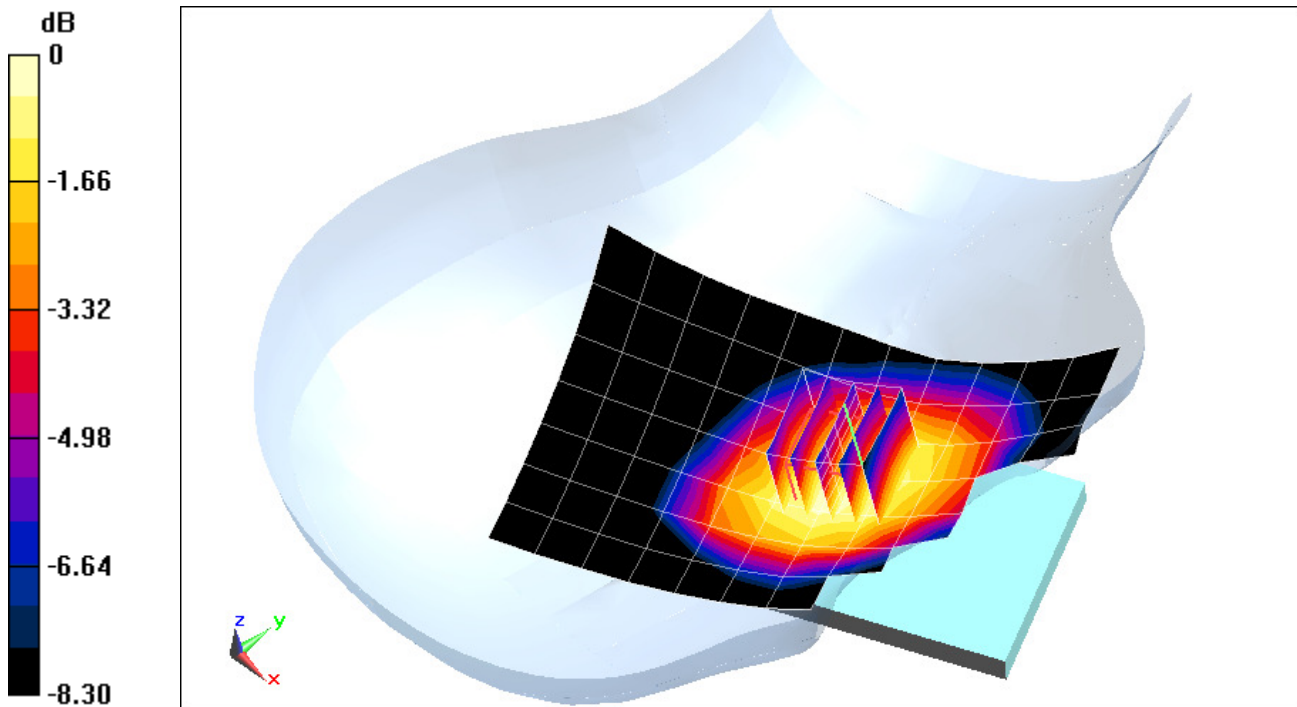

0 dB = 0.262 W/kg = -5.82 dBW/kg

PCTEST ENGINEERING LABORATORY, INC.

DUT: ZNFLS450; Type: Portable Handset; Serial: 06731

Communication System: UID 0, LTE Band 26 (0); Frequency: 836.5 MHz; Duty Cycle: 1:1
Medium: 835 Head Medium parameters used (interpolated):
 $f = 836.5 \text{ MHz}$; $\sigma = 0.897 \text{ S/m}$; $\epsilon_r = 40.028$; $\rho = 1000 \text{ kg/m}^3$
Phantom section: Right Section

Test Date: 04-08-2016; Ambient Temp: 23.5°C; Tissue Temp: 22.0°C

Probe: ES3DV3 - SN3288; ConvF(6.41, 6.41, 6.41); Calibrated: 9/18/2015;
Sensor-Surface: 3mm (Mechanical Surface Detection)
Electronics: DAE4 Sn1364; Calibrated: 9/18/2015
Phantom: Main TWIN SAM; Type: QD000P40CC; Serial: TP-1406
Measurement SW: DASY52, Version 52.8 (8); SEMCAD X Version 14.6.10 (7331)

Mode: LTE Band 26 (Cell.), Right Head, Cheek, Mid.ch
15 MHz Bandwidth, QPSK, 1 RB, 74 RB Offset

Area Scan (9x15x1): Measurement grid: $dx=15\text{mm}$, $dy=15\text{mm}$
Zoom Scan (6x5x7)/Cube 0: Measurement grid: $dx=8\text{mm}$, $dy=8\text{mm}$, $dz=5\text{mm}$
Reference Value = 22.50 V/m; Power Drift = 0.11 dB
Peak SAR (extrapolated) = 0.579 W/kg
SAR(1 g) = 0.425 W/kg

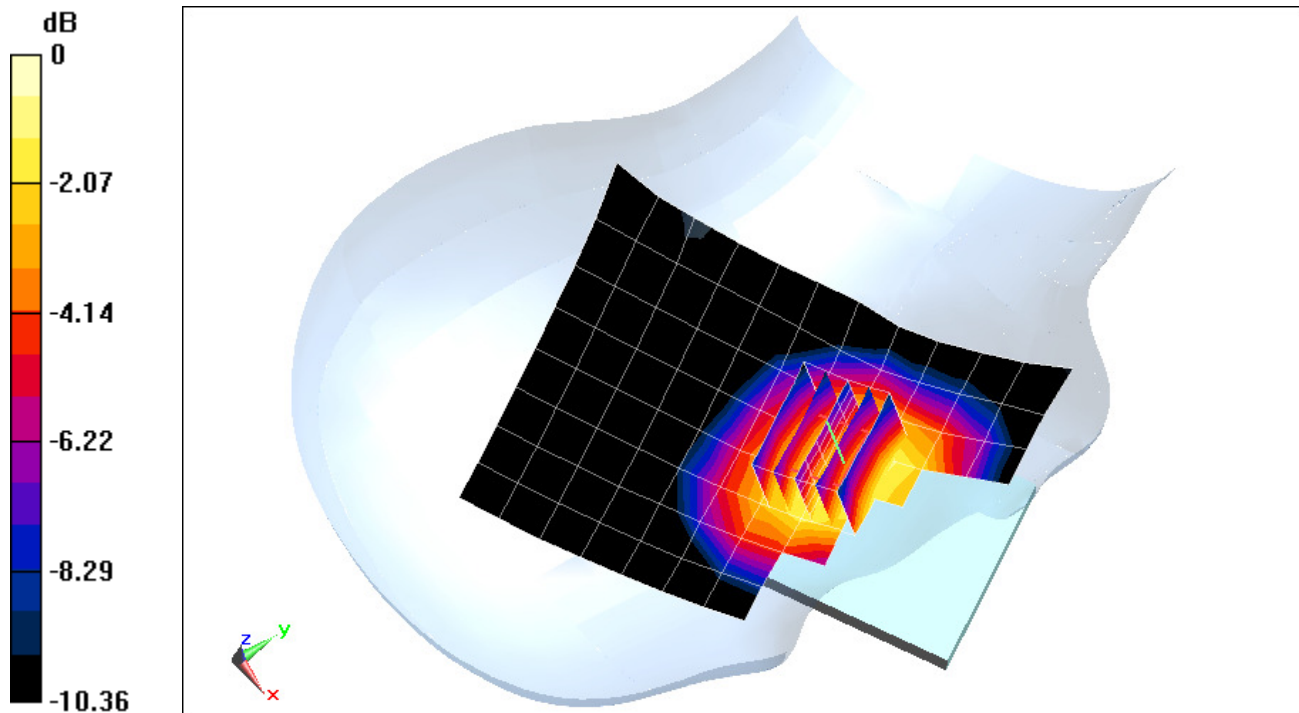

0 dB = 0.482 W/kg = -3.17 dBW/kg

PCTEST ENGINEERING LABORATORY, INC.

DUT: ZNFLS450; Type: Portable Handset; Serial: 06731

Communication System: UID 0, LTE Band 4 (AWS); Frequency: 1732.5 MHz; Duty Cycle: 1:1
Medium: 1750 Head Medium parameters used (interpolated):
 $f = 1732.5 \text{ MHz}$; $\sigma = 1.318 \text{ S/m}$; $\epsilon_r = 39.498$; $\rho = 1000 \text{ kg/m}^3$
Phantom section: Left Section

Test Date: 04-07-2016; Ambient Temp: 23.0°C; Tissue Temp: 23.2°C

Probe: ES3DV2 - SN3022; ConvF(5.08, 5.08, 5.08); Calibrated: 8/26/2015;
Sensor-Surface: 3mm (Mechanical Surface Detection)
Electronics: DAE4 Sn1323; Calibrated: 9/16/2015
Phantom: SAM Right; Type: QD000P40CD; Serial: TP:7535
Measurement SW: DASY52, Version 52.8 (8); SEMCAD X Version 14.6.10 (7331)

Mode: LTE Band 4 (AWS), Left Head, Cheek, Mid.ch
20 MHz Bandwidth, QPSK, 1 RB, 50 RB Offset

Area Scan (9x15x1): Measurement grid: $dx=15\text{mm}$, $dy=15\text{mm}$
Zoom Scan (5x5x7)/Cube 0: Measurement grid: $dx=8\text{mm}$, $dy=8\text{mm}$, $dz=5\text{mm}$
Reference Value = 19.07 V/m; Power Drift = 0.21 dB
Peak SAR (extrapolated) = 0.587 W/kg
SAR(1 g) = 0.390 W/kg

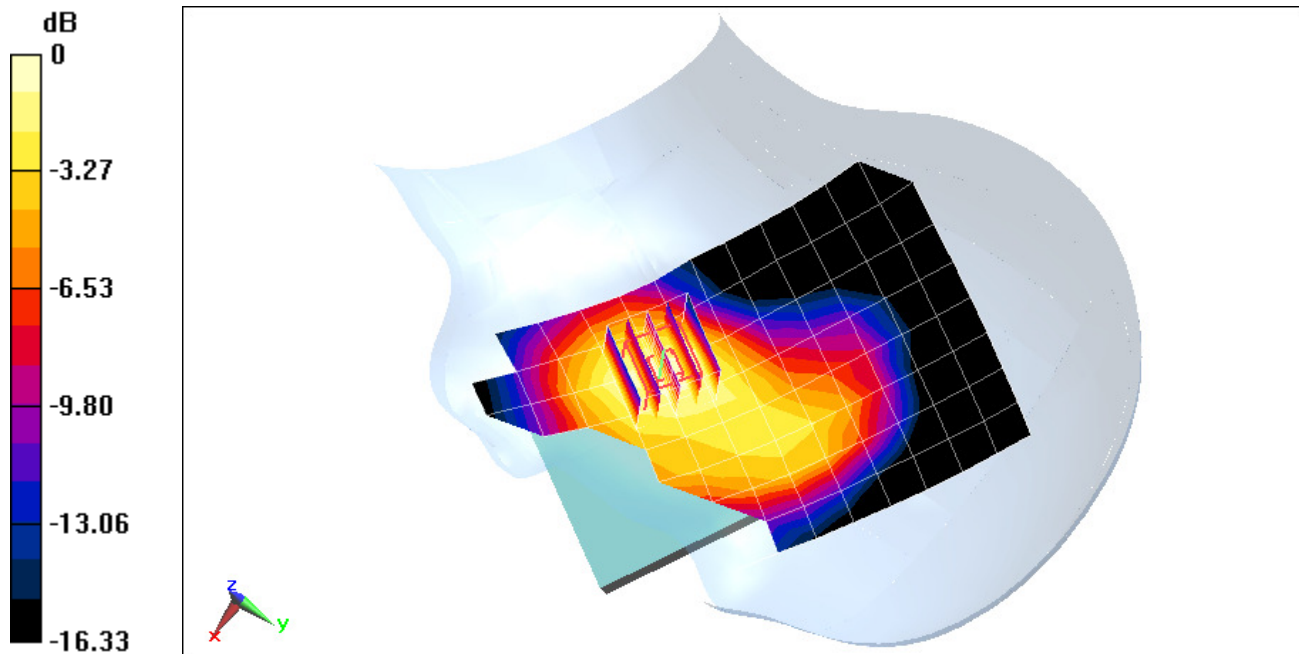

0 dB = 0.446 W/kg = -3.51 dBW/kg

PCTEST ENGINEERING LABORATORY, INC.

DUT: ZNFLS450; Type: Portable Handset; Serial: 06731

Communication System: UID 0, LTE Band 25 (PCS); Frequency: 1882.5 MHz; Duty Cycle: 1:1
Medium: 1900 Head Medium parameters used (interpolated):
 $f = 1882.5 \text{ MHz}$; $\sigma = 1.442 \text{ S/m}$; $\epsilon_r = 40.29$; $\rho = 1000 \text{ kg/m}^3$
Phantom section: Left Section

Test Date: 04-11-2016; Ambient Temp: 23.5°C; Tissue Temp: 22.0°C

Probe: ES3DV3 - SN3332; ConvF(5.06, 5.06, 5.06); Calibrated: 9/18/2015;
Sensor-Surface: 3mm (Mechanical Surface Detection)
Electronics: DAE4 Sn1466; Calibrated: 1/15/2016
Phantom: SAM Main ; Type: QD000P40CC; Serial: TP 1114
Measurement SW: DASY52, Version 52.8 (8); SEMCAD X Version 14.6.10 (7331)

Mode: LTE Band 25 (PCS), Left Head, Cheek, Mid.ch
20 MHz Bandwidth, QPSK, 1 RB, 50 RB Offset

Area Scan (7x14x1): Measurement grid: $dx=15\text{mm}$, $dy=15\text{mm}$
Zoom Scan (5x5x7)/Cube 0: Measurement grid: $dx=8\text{mm}$, $dy=8\text{mm}$, $dz=5\text{mm}$
Reference Value = 19.37 V/m; Power Drift = 0.04 dB
Peak SAR (extrapolated) = 0.797 W/kg
SAR(1 g) = 0.498 W/kg

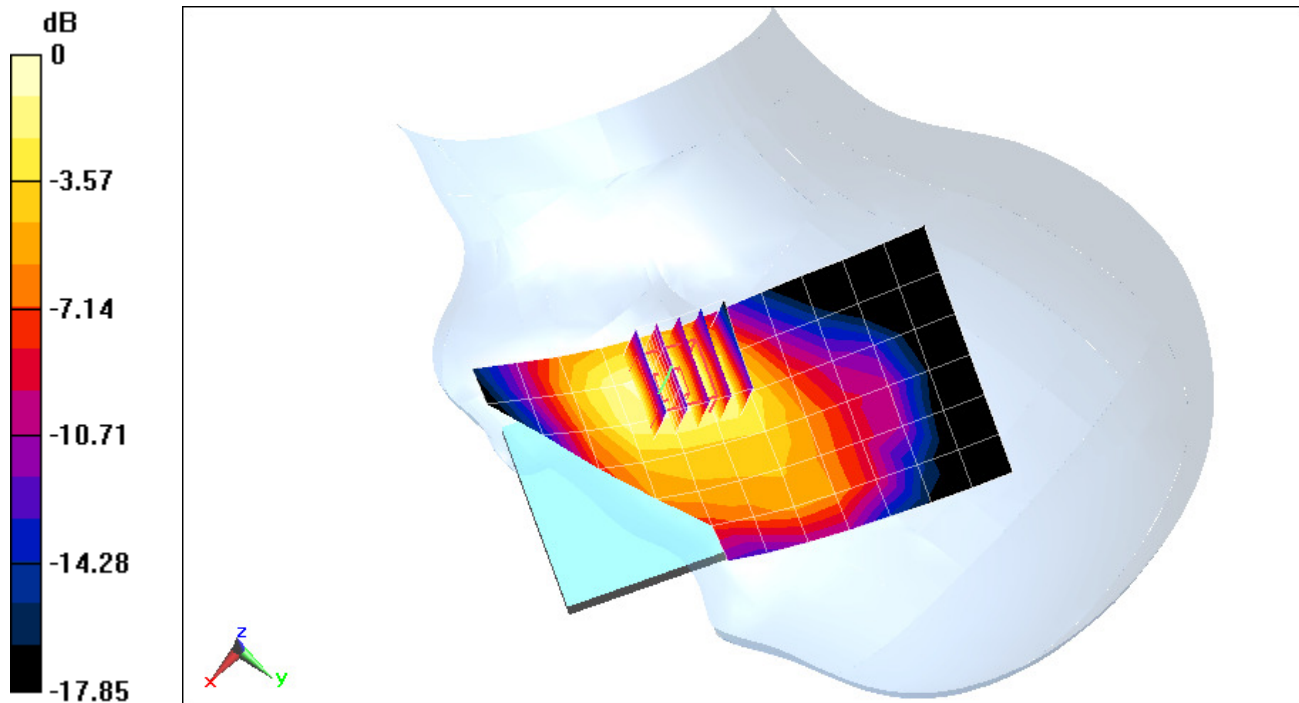

0 dB = 0.599 W/kg = -2.23 dBW/kg

PCTEST ENGINEERING LABORATORY, INC.

DUT: ZNFLS450; Type: Portable Handset; Serial: 06731

Communication System: UID 0, LTE Band 41 (0); Frequency: 2680 MHz; Duty Cycle: 1:1.59
Medium: 2450 Head Medium parameters used (interpolated):
 $f = 2680 \text{ MHz}$; $\sigma = 2.123 \text{ S/m}$; $\epsilon_r = 38.708$; $\rho = 1000 \text{ kg/m}^3$
Phantom section: Right Section

Test Date: 04-11-2016; Ambient Temp: 22.7°C; Tissue Temp: 23.0°C

Probe: ES3DV3 - SN3319; ConvF(4.33, 4.33, 4.33); Calibrated: 3/18/2016;
Sensor-Surface: 3mm (Mechanical Surface Detection)
Electronics: DAE4 Sn1368; Calibrated: 3/14/2016
Phantom: SAM with CRP v5.0 (Right); Type: QD000P40CD; Serial: TP:1759
Measurement SW: DASY52, Version 52.8 (8); SEMCAD X Version 14.6.10 (7331)

Mode: LTE Band 41, Right Head, Cheek, High.ch
20 MHz Bandwidth, QPSK, 1 RB, 0 RB Offset

Area Scan (10x15x1): Measurement grid: $dx=12\text{mm}$, $dy=12\text{mm}$
Zoom Scan (7x7x7)/Cube 0: Measurement grid: $dx=5\text{mm}$, $dy=5\text{mm}$, $dz=5\text{mm}$
Reference Value = 15.70 V/m; Power Drift = 0.00 dB
Peak SAR (extrapolated) = 0.840 W/kg
SAR(1 g) = 0.425 W/kg

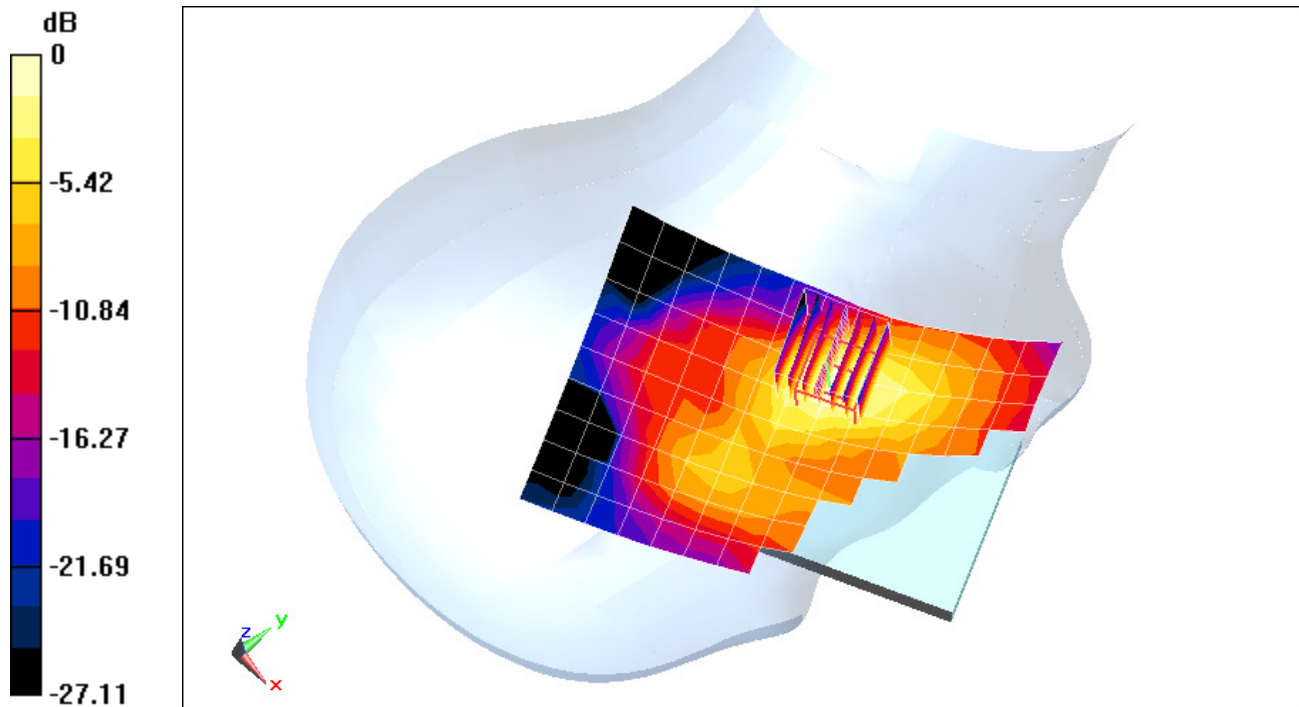

0 dB = 0.545 W/kg = -2.64 dBW/kg

PCTEST ENGINEERING LABORATORY, INC.

DUT: ZNFLS450; Type: Portable Handset; Serial: 06723

Communication System: UID 0, IEEE 802.11b (0); Frequency: 2437 MHz; Duty Cycle: 1:1
Medium: 2450 Head Medium parameters used (interpolated):
 $f = 2437 \text{ MHz}$; $\sigma = 1.861 \text{ S/m}$; $\epsilon_r = 37.871$; $\rho = 1000 \text{ kg/m}^3$
Phantom section: Right Section

Test Date: 04-09-2016; Ambient Temp: 20.1°C; Tissue Temp: 21.9°C

Probe: ES3DV3 - SN3318; ConvF(4.57, 4.57, 4.57); Calibrated: 2/19/2016;
Sensor-Surface: 3mm (Mechanical Surface Detection)

Electronics: DAE4 Sn665; Calibrated: 2/19/2016

Phantom: SAM with CRP v4.0; Type: QD000P40CD; Serial: TP:1800

Measurement SW: DASY52, Version 52.8 (8); SEMCAD X Version 14.6.10 (7331)

Mode: IEEE 802.11b, 22 MHz Bandwidth, Right Head, Cheek, Ch 06, 1 Mbps

Area Scan (10x16x1): Measurement grid: dx=12mm, dy=12mm

Zoom Scan (7x7x7)/Cube 0: Measurement grid: dx=5mm, dy=5mm, dz=5mm

Reference Value = 19.37 V/m; Power Drift = -0.02 dB

Peak SAR (extrapolated) = 1.47 W/kg

SAR(1 g) = 0.610 W/kg

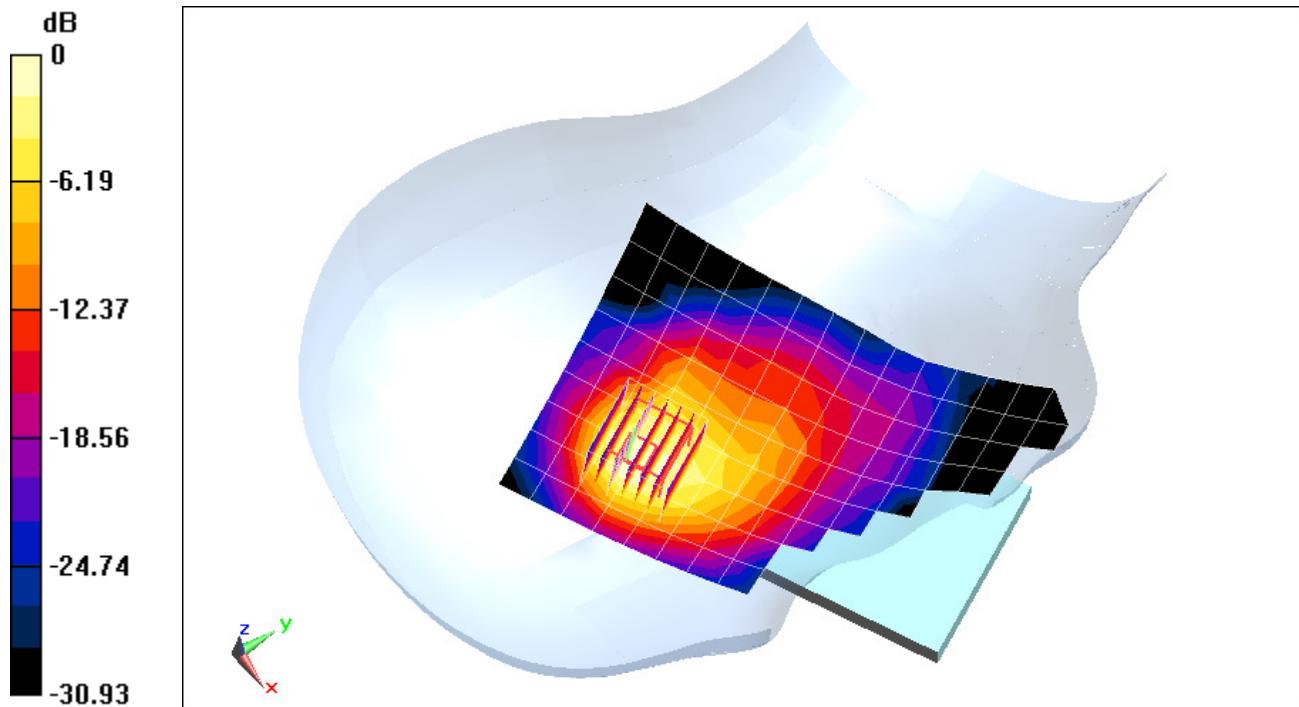

0 dB = 0.799 W/kg = -0.97 dBW/kg

PCTEST ENGINEERING LABORATORY, INC.

DUT: ZNFLS450; Type: Portable Handset; Serial: 06715

Communication System: UID 0, CDMA; Frequency: 820.1 MHz; Duty Cycle: 1:1
Medium: 835 Body Medium parameters used (interpolated):
 $f = 820.1 \text{ MHz}$; $\sigma = 0.958 \text{ S/m}$; $\epsilon_r = 53.152$; $\rho = 1000 \text{ kg/m}^3$
Phantom section: Flat Section; Space: 1.0 cm

Test Date: 04-10-2016; Ambient Temp: 20.1°C; Tissue Temp: 20.5°C

Probe: ES3DV3 - SN3318; ConvF(6.11, 6.11, 6.11); Calibrated: 2/19/2016;
Sensor-Surface: 3mm (Mechanical Surface Detection)
Electronics: DAE4 Sn665; Calibrated: 2/19/2016
Phantom: SAM with CRP v4.0; Type: QD000P40CD; Serial: TP:1800
Measurement SW: DASYS2, Version 52.8 (8); SEMCAD X Version 14.6.10 (7331)

Mode: Cell. CDMA, Rule Part 90S Body SAR, Back side, Mid.ch

Area Scan (9x15x1): Measurement grid: dx=15mm, dy=15mm
Zoom Scan (5x5x7)/Cube 0: Measurement grid: dx=8mm, dy=8mm, dz=5mm
Reference Value = 32.42 V/m; Power Drift = -0.01 dB
Peak SAR (extrapolated) = 1.17 W/kg
SAR(1 g) = 0.929 W/kg

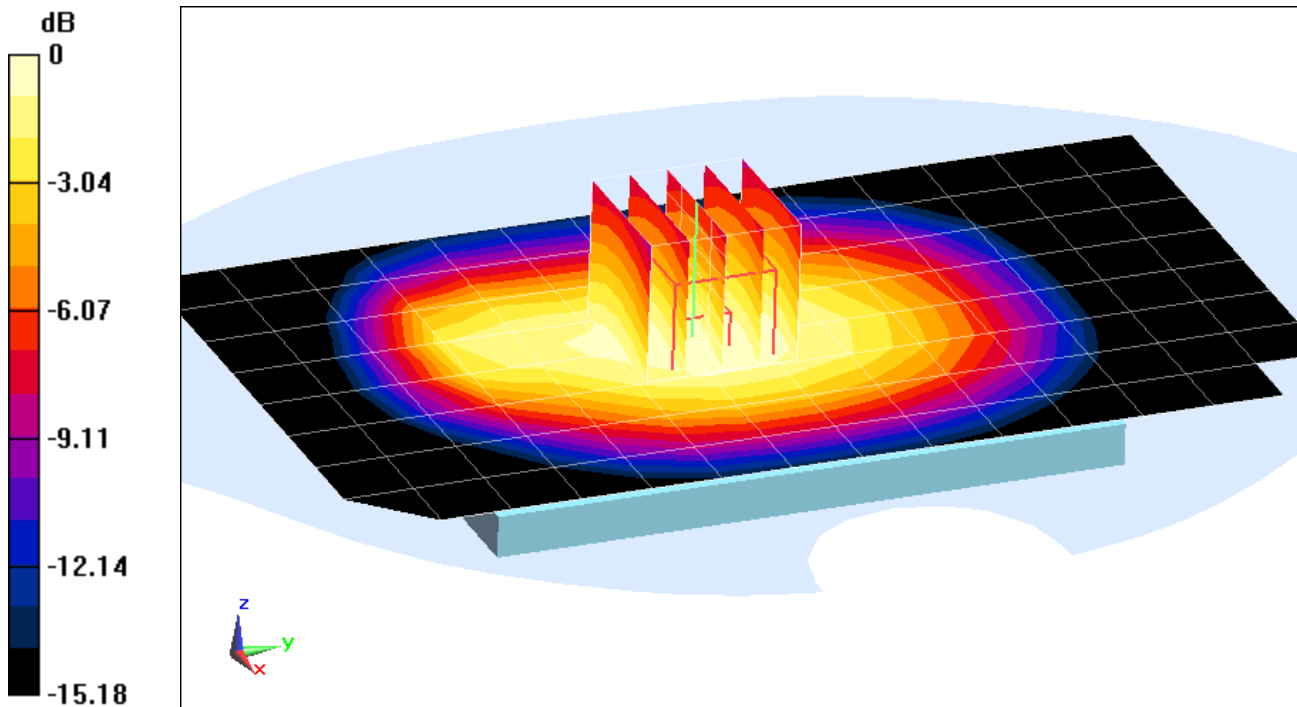

0 dB = 1.02 W/kg = 0.09 dBW/kg

PCTEST ENGINEERING LABORATORY, INC.

DUT: ZNFLS450; Type: Portable Handset; Serial: 06715

Communication System: UID 0, CDMA; Frequency: 820.1 MHz; Duty Cycle: 1:1
Medium: 835 Body Medium parameters used (interpolated):
 $f = 820.1 \text{ MHz}$; $\sigma = 0.958 \text{ S/m}$; $\epsilon_r = 53.152$; $\rho = 1000 \text{ kg/m}^3$
Phantom section: Flat Section; Space: 1.0 cm

Test Date: 04-10-2016; Ambient Temp: 20.1°C; Tissue Temp: 20.5°C

Probe: ES3DV3 - SN3318; ConvF(6.11, 6.11, 6.11); Calibrated: 2/19/2016;
Sensor-Surface: 3mm (Mechanical Surface Detection)
Electronics: DAE4 Sn665; Calibrated: 2/19/2016
Phantom: SAM with CRP v4.0; Type: QD000P40CD; Serial: TP:1800
Measurement SW: DASYS2, Version 52.8 (8); SEMCAD X Version 14.6.10 (7331)

Mode: Cell. EVDO Rev. 0, Rule Part 90S Body SAR, Back side, Mid.ch

Area Scan (9x15x1): Measurement grid: dx=15mm, dy=15mm
Zoom Scan (5x5x7)/Cube 0: Measurement grid: dx=8mm, dy=8mm, dz=5mm
Reference Value = 31.42 V/m; Power Drift = 0.04 dB
Peak SAR (extrapolated) = 1.14 W/kg
SAR(1 g) = 0.894 W/kg

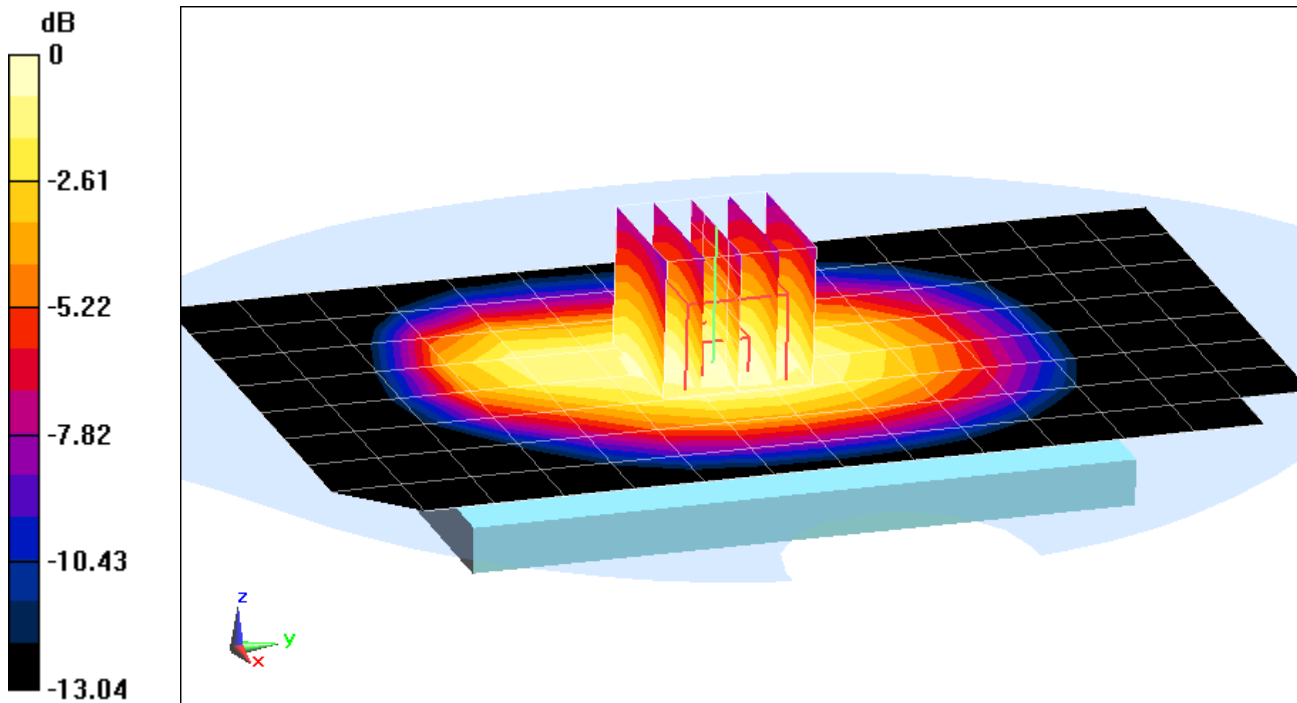

0 dB = 0.989 W/kg = -0.05 dBW/kg

PCTEST ENGINEERING LABORATORY, INC.

DUT: ZNFLS450; Type: Portable Handset; Serial: 06715

Communication System: UID 0, CDMA; Frequency: 836.52 MHz; Duty Cycle: 1:1
Medium: 835 Body Medium parameters used (interpolated):
 $f = 836.52 \text{ MHz}$; $\sigma = 0.974 \text{ S/m}$; $\epsilon_r = 52.939$; $\rho = 1000 \text{ kg/m}^3$
Phantom section: Flat Section; Space: 1.0 cm

Test Date: 04-10-2016; Ambient Temp: 20.1°C; Tissue Temp: 20.5°C

Probe: ES3DV3 - SN3318; ConvF(6.11, 6.11, 6.11); Calibrated: 2/19/2016;
Sensor-Surface: 3mm (Mechanical Surface Detection)
Electronics: DAE4 Sn665; Calibrated: 2/19/2016
Phantom: SAM with CRP v4.0; Type: QD000P40CD; Serial: TP:1800
Measurement SW: DASY52, Version 52.8 (8); SEMCAD X Version 14.6.10 (7331)

Mode: Cell. CDMA, Rule Part 22H, Body SAR, Back side, Mid.ch

Area Scan (9x15x1): Measurement grid: dx=15mm, dy=15mm
Zoom Scan (5x5x7)/Cube 0: Measurement grid: dx=8mm, dy=8mm, dz=5mm
Reference Value = 31.53 V/m; Power Drift = -0.05 dB
Peak SAR (extrapolated) = 1.12 W/kg
SAR(1 g) = 0.887 W/kg

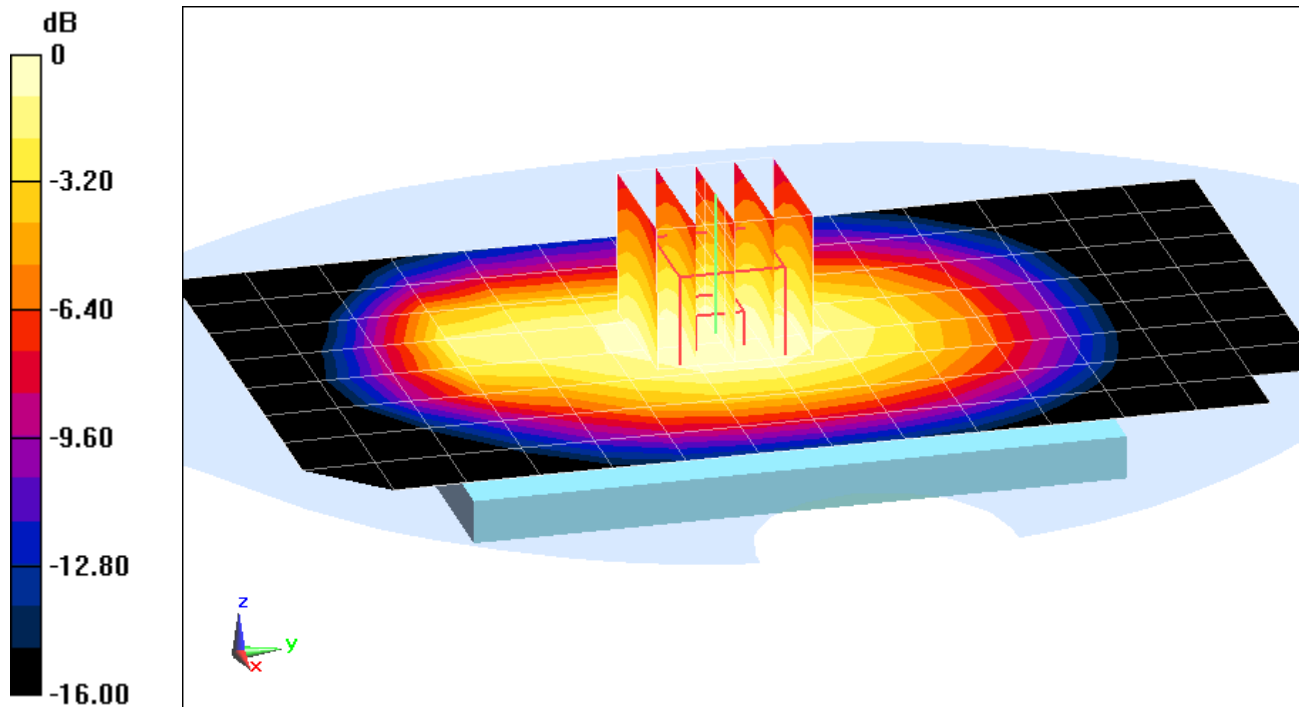

0 dB = 0.975 W/kg = -0.11 dBW/kg

PCTEST ENGINEERING LABORATORY, INC.

DUT: ZNFLS450; Type: Portable Handset; Serial: 06715

Communication System: UID 0, CDMA; Frequency: 836.52 MHz; Duty Cycle: 1:1
Medium: 835 Body Medium parameters used (interpolated):
 $f = 836.52 \text{ MHz}$; $\sigma = 0.974 \text{ S/m}$; $\epsilon_r = 52.939$; $\rho = 1000 \text{ kg/m}^3$
Phantom section: Flat Section; Space: 1.0 cm

Test Date: 04-10-2016; Ambient Temp: 20.1°C; Tissue Temp: 20.5°C

Probe: ES3DV3 - SN3318; ConvF(6.11, 6.11, 6.11); Calibrated: 2/19/2016;
Sensor-Surface: 3mm (Mechanical Surface Detection)
Electronics: DAE4 Sn665; Calibrated: 2/19/2016
Phantom: SAM with CRP v4.0; Type: QD000P40CD; Serial: TP:1800
Measurement SW: DASY52, Version 52.8 (8); SEMCAD X Version 14.6.10 (7331)

Mode: Cell. EVDO Rev. 0, Rule Part 22H, Body SAR, Back side, Mid.ch

Area Scan (9x15x1): Measurement grid: dx=15mm, dy=15mm
Zoom Scan (5x5x7)/Cube 0: Measurement grid: dx=8mm, dy=8mm, dz=5mm
Reference Value = 31.22 V/m; Power Drift = 0.05 dB
Peak SAR (extrapolated) = 1.11 W/kg
SAR(1 g) = 0.883 W/kg

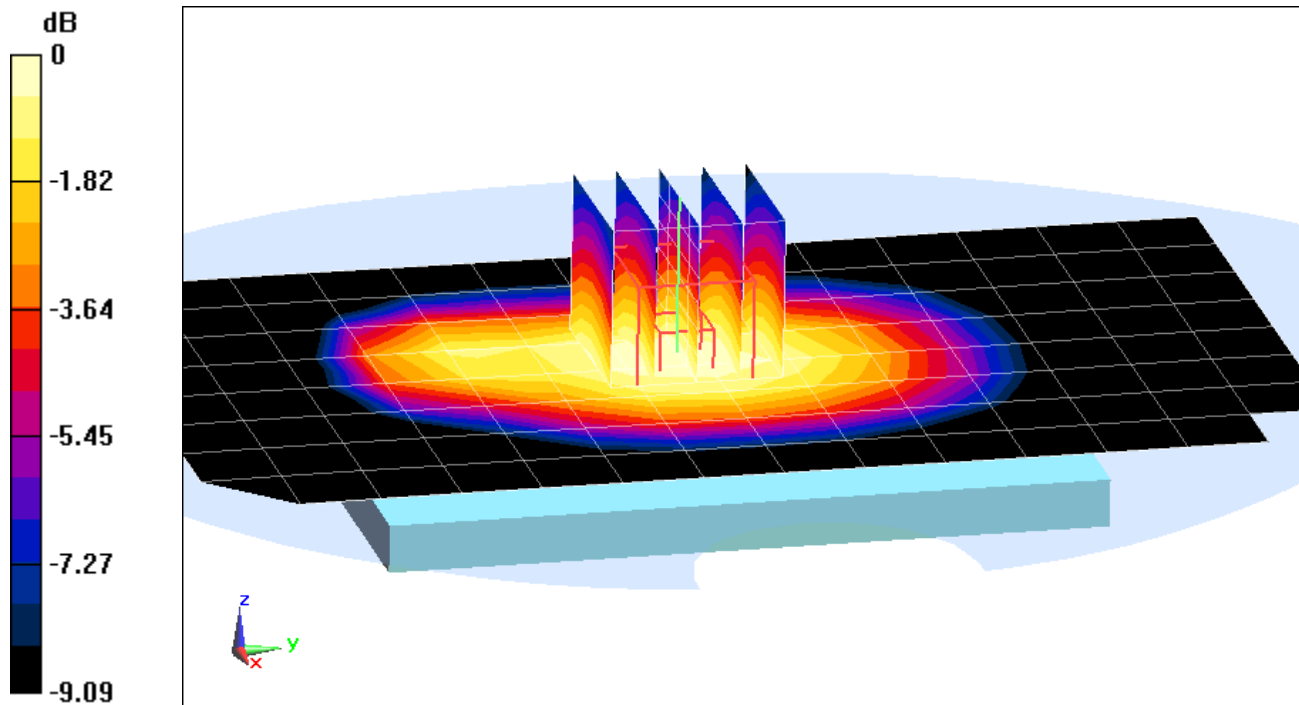

0 dB = 0.973 W/kg = -0.12 dBW/kg

PCTEST ENGINEERING LABORATORY, INC.

DUT: ZNFLS450; Type: Portable Handset; Serial: 06715

Communication System: UID 0, CDMA; Frequency: 1851.25 MHz; Duty Cycle: 1:1
Medium: 1900 Body Medium parameters used (interpolated):
 $f = 1851.25 \text{ MHz}$; $\sigma = 1.472 \text{ S/m}$; $\epsilon_r = 51.587$; $\rho = 1000 \text{ kg/m}^3$
Phantom section: Flat Section; Space: 1.0 cm

Test Date: 04-05-2016; Ambient Temp: 23.1°C; Tissue Temp: 22.2°C

Probe: ES3DV3 - SN3334; ConvF(4.84, 4.84, 4.84); Calibrated: 11/17/2015;
Sensor-Surface: 3mm (Mechanical Surface Detection)
Electronics: DAE4 Sn1415; Calibrated: 11/11/2015
Phantom: SAM Front; Type: SAM; Serial: 1686
Measurement SW: DASY52, Version 52.8 (8); SEMCAD X Version 14.6.10 (7331)

Mode: PCS CDMA, Body SAR, Back side, Low.ch

Area Scan (9x14x1): Measurement grid: dx=15mm, dy=15mm
Zoom Scan (6x5x7)/Cube 0: Measurement grid: dx=8mm, dy=8mm, dz=5mm
Reference Value = 24.59 V/m; Power Drift = 0.01 dB
Peak SAR (extrapolated) = 1.31 W/kg
SAR(1 g) = 0.797 W/kg

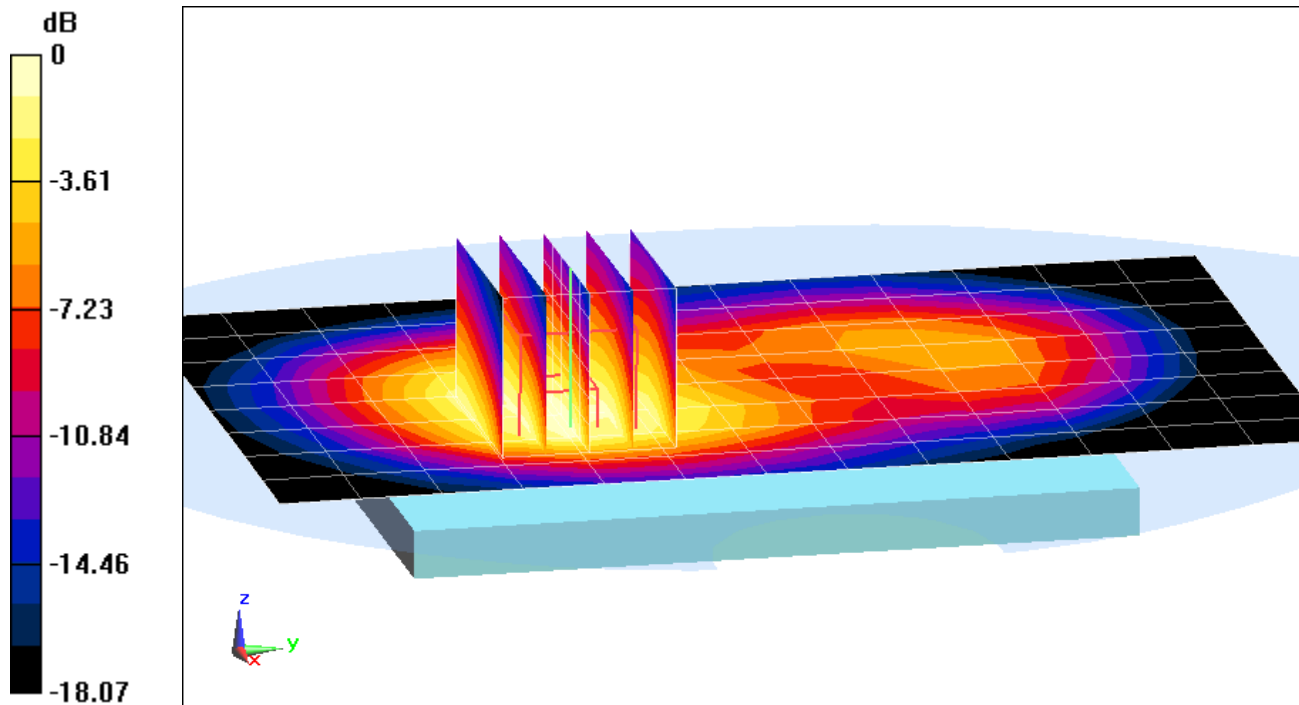

0 dB = 0.932 W/kg = -0.31 dBW/kg

PCTEST ENGINEERING LABORATORY, INC.

DUT: ZNFLS450; Type: Portable Handset; Serial: 06715

Communication System: UID 0, CDMA; Frequency: 1908.75 MHz; Duty Cycle: 1:1
Medium: 1900 Body Medium parameters used (interpolated):
 $f = 1908.75 \text{ MHz}$; $\sigma = 1.535 \text{ S/m}$; $\epsilon_r = 51.395$; $\rho = 1000 \text{ kg/m}^3$
Phantom section: Flat Section; Space: 1.0 cm

Test Date: 04-05-2016; Ambient Temp: 23.1°C; Tissue Temp: 22.2°C

Probe: ES3DV3 - SN3334; ConvF(4.84, 4.84, 4.84); Calibrated: 11/17/2015;
Sensor-Surface: 3mm (Mechanical Surface Detection)
Electronics: DAE4 Sn1415; Calibrated: 11/11/2015
Phantom: SAM Front; Type: SAM; Serial: 1686
Measurement SW: DASY52, Version 52.8 (8); SEMCAD X Version 14.6.10 (7331)

Mode: PCS EVDO Rev 0, Body SAR, Front side, High.ch

Area Scan (9x14x1): Measurement grid: dx=15mm, dy=15mm
Zoom Scan (6x6x7)/Cube 0: Measurement grid: dx=8mm, dy=8mm, dz=5mm
Reference Value = 24.13 V/m; Power Drift = -0.04 dB
Peak SAR (extrapolated) = 1.36 W/kg
SAR(1 g) = 0.788 W/kg

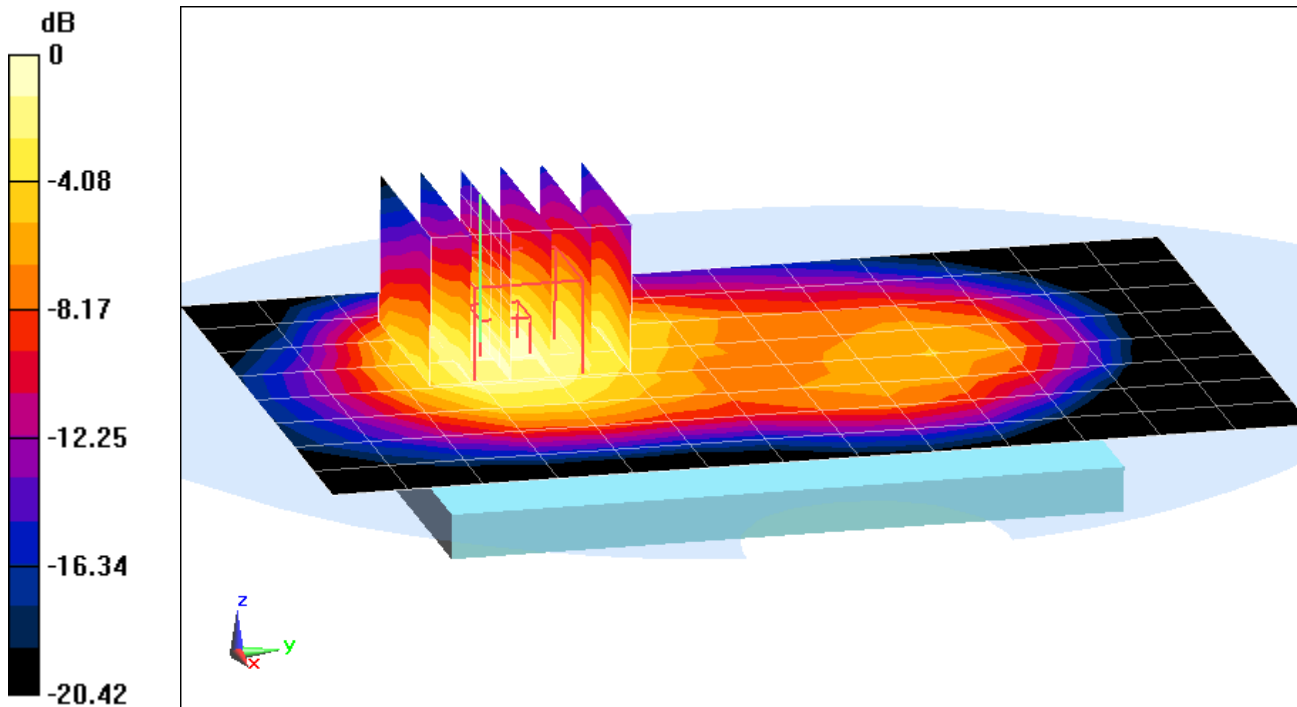

0 dB = 0.948 W/kg = -0.23 dBW/kg

PCTEST ENGINEERING LABORATORY, INC.

DUT: ZNFLS450; Type: Portable Handset; Serial: 06715

Communication System: UID 0, GSM GPRS; 2 Tx slots (0); Frequency: 824.2 MHz; Duty Cycle: 1:4.15
Medium: 835 Body Medium parameters used (interpolated):
 $f = 824.2 \text{ MHz}$; $\sigma = 0.962 \text{ S/m}$; $\epsilon_r = 53.097$; $\rho = 1000 \text{ kg/m}^3$
Phantom section: Flat Section; Space: 1.0 cm

Test Date: 04-10-2016; Ambient Temp: 20.1°C; Tissue Temp: 20.5°C

Probe: ES3DV3 - SN3318; ConvF(6.11, 6.11, 6.11); Calibrated: 2/19/2016;
Sensor-Surface: 3mm (Mechanical Surface Detection)
Electronics: DAE4 Sn665; Calibrated: 2/19/2016
Phantom: SAM with CRP v4.0; Type: QD000P40CD; Serial: TP:1800
Measurement SW: DASY52, Version 52.8 (8); SEMCAD X Version 14.6.10 (7331)

Mode: GPRS 850, Body SAR, Back side, Low.ch, 2 Tx Slots

Area Scan (9x15x1): Measurement grid: dx=15mm, dy=15mm
Zoom Scan (5x5x7)/Cube 0: Measurement grid: dx=8mm, dy=8mm, dz=5mm
Reference Value = 25.45 V/m; Power Drift = 0.11 dB
Peak SAR (extrapolated) = 1.01 W/kg
SAR(1 g) = 0.799 W/kg

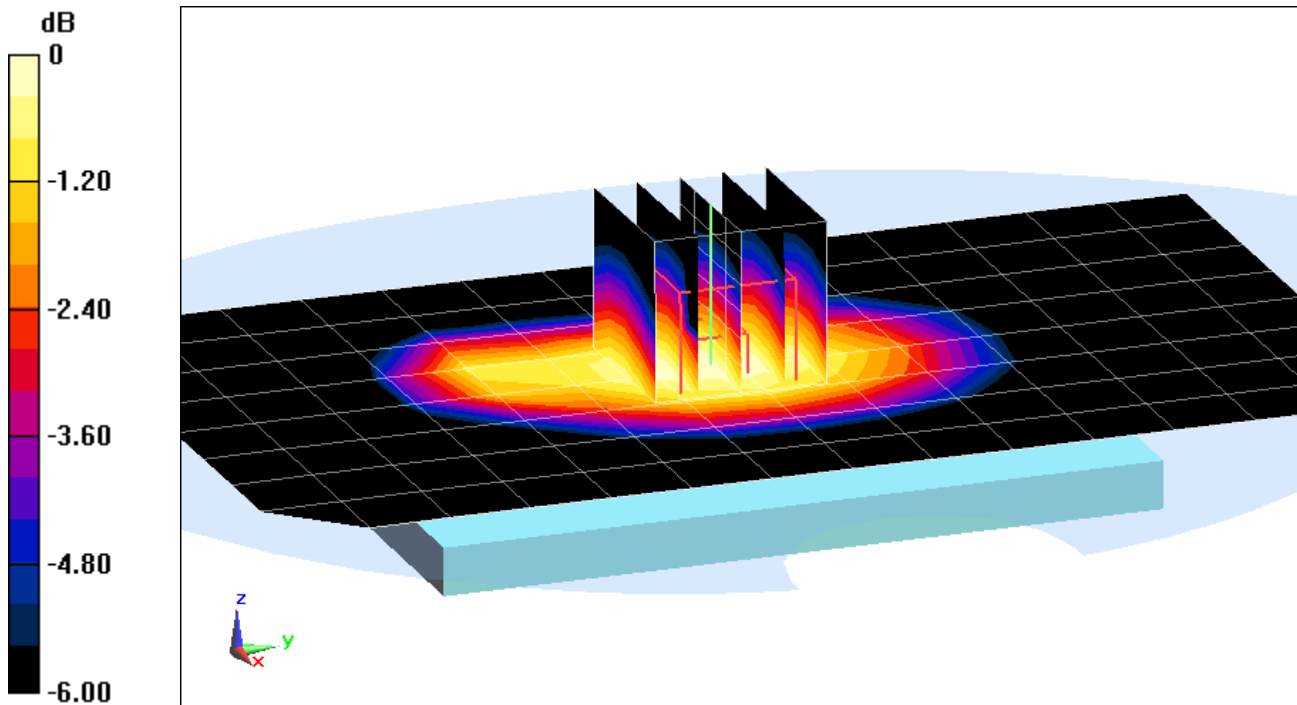

0 dB = 0.637 W/kg = -1.96 dBW/kg

PCTEST ENGINEERING LABORATORY, INC.

DUT: ZNFLS450; Type: Portable Handset; Serial: 06715

Communication System: UID 0, GSM; Frequency: 1880 MHz; Duty Cycle: 1:8.3
Medium: 1900 Body Medium parameters used:
 $f = 1880 \text{ MHz}$; $\sigma = 1.504 \text{ S/m}$; $\epsilon_r = 51.5$; $\rho = 1000 \text{ kg/m}^3$
Phantom section: Flat Section; Space: 1.0 cm

Test Date: 04-05-2016; Ambient Temp: 23.1°C; Tissue Temp: 22.2°C

Probe: ES3DV3 - SN3334; ConvF(4.84, 4.84, 4.84); Calibrated: 11/17/2015;
Sensor-Surface: 3mm (Mechanical Surface Detection)
Electronics: DAE4 Sn1415; Calibrated: 11/11/2015
Phantom: SAM Front; Type: SAM; Serial: 1686
Measurement SW: DASY52, Version 52.8 (8); SEMCAD X Version 14.6.10 (7331)

Mode: GSM 1900, Body SAR, Back side, Mid.ch

Area Scan (9x15x1): Measurement grid: dx=15mm, dy=15mm
Zoom Scan (5x5x7)/Cube 0: Measurement grid: dx=8mm, dy=8mm, dz=5mm
Reference Value = 15.93 V/m; Power Drift = -0.01 dB
Peak SAR (extrapolated) = 0.584 W/kg
SAR(1 g) = 0.346 W/kg

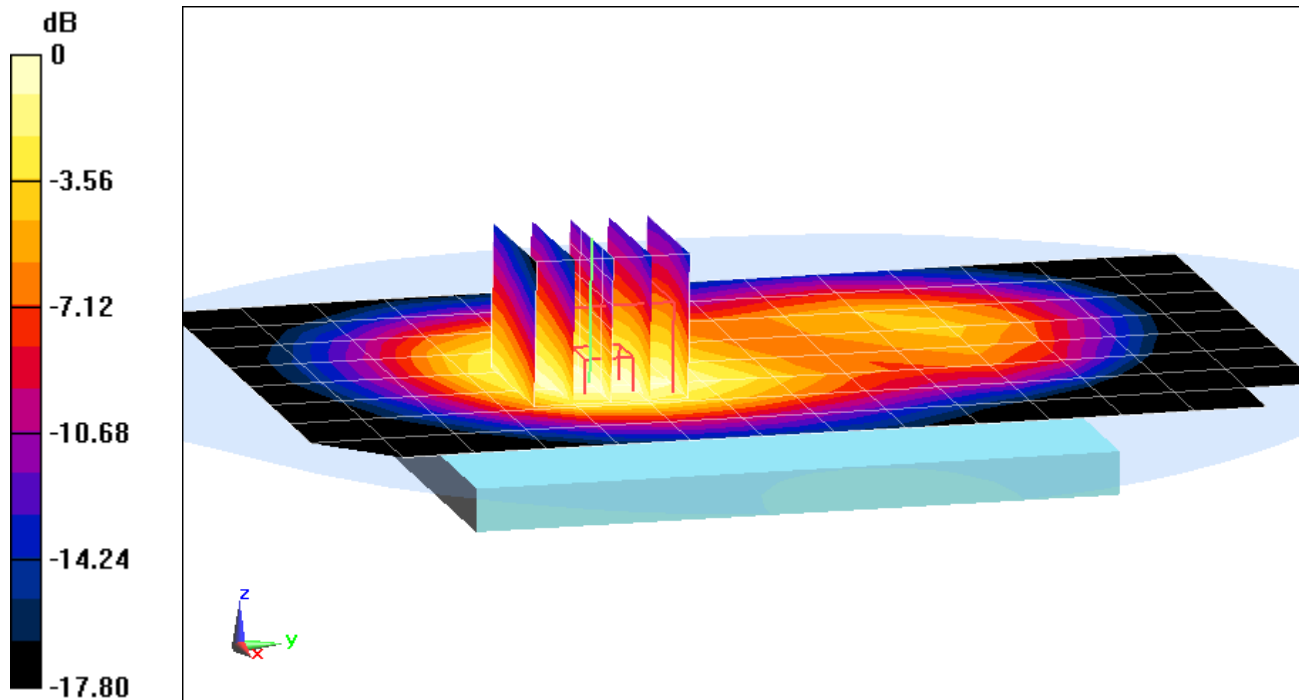

0 dB = 0.408 W/kg = -3.89 dBW/kg

PCTEST ENGINEERING LABORATORY, INC.

DUT: ZNFLS450; Type: Portable Handset; Serial: 06715

Communication System: UID 0, GSM GPRS; 2 Tx slots; Frequency: 1880 MHz; Duty Cycle: 1:4.15

Medium: 1900 Body Medium parameters used:

$f = 1880 \text{ MHz}$; $\sigma = 1.504 \text{ S/m}$; $\epsilon_r = 51.5$; $\rho = 1000 \text{ kg/m}^3$

Phantom section: Flat Section; Space: 1.0 cm

Test Date: 04-05-2016; Ambient Temp: 23.1°C; Tissue Temp: 22.2°C

Probe: ES3DV3 - SN3334; ConvF(4.84, 4.84, 4.84); Calibrated: 11/17/2015;

Sensor-Surface: 3mm (Mechanical Surface Detection)

Electronics: DAE4 Sn1415; Calibrated: 11/11/2015

Phantom: SAM Front; Type: SAM; Serial: 1686

Measurement SW: DASY52, Version 52.8 (8); SEMCAD X Version 14.6.10 (7331)

Mode: GPRS 1900, Body SAR, Back side, Mid.ch, 2 Tx Slots

Area Scan (9x15x1): Measurement grid: dx=15mm, dy=15mm

Zoom Scan (6x5x7)/Cube 0: Measurement grid: dx=8mm, dy=8mm, dz=5mm

Reference Value = 16.35 V/m; Power Drift = -0.17 dB

Peak SAR (extrapolated) = 0.555 W/kg

SAR(1 g) = 0.330 W/kg

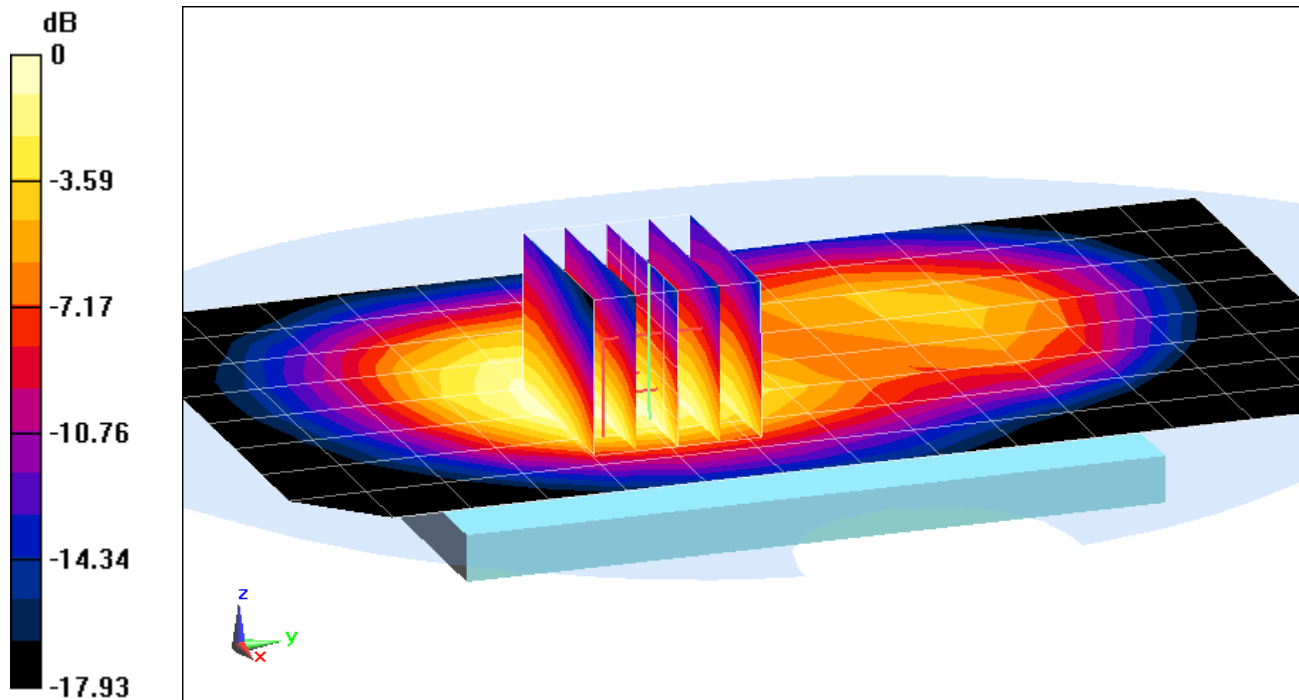

0 dB = 0.398 W/kg = -4.00 dBW/kg

PCTEST ENGINEERING LABORATORY, INC.

DUT: ZNFLS450; Type: Portable Handset; Serial: 06723

Communication System: UID 0, UMTS; Frequency: 836.6 MHz; Duty Cycle: 1:1
Medium: 835 Body Medium parameters used (interpolated):
 $f = 836.6 \text{ MHz}$; $\sigma = 0.974 \text{ S/m}$; $\epsilon_r = 52.938$; $\rho = 1000 \text{ kg/m}^3$
Phantom section: Flat Section; Space: 1.0 cm

Test Date: 04-10-2016; Ambient Temp: 20.1°C; Tissue Temp: 20.5°C

Probe: ES3DV3 - SN3318; ConvF(6.11, 6.11, 6.11); Calibrated: 2/19/2016;
Sensor-Surface: 3mm (Mechanical Surface Detection)
Electronics: DAE4 Sn665; Calibrated: 2/19/2016
Phantom: SAM with CRP v4.0; Type: QD000P40CD; Serial: TP:1800
Measurement SW: DASY52, Version 52.8 (8); SEMCAD X Version 14.6.10 (7331)

Mode: UMTS 850, Body SAR, Back side, Mid.ch

Area Scan (9x15x1): Measurement grid: dx=15mm, dy=15mm
Zoom Scan (5x5x7)/Cube 0: Measurement grid: dx=8mm, dy=8mm, dz=5mm
Reference Value = 24.86 V/m; Power Drift = 0.06 dB
Peak SAR (extrapolated) = 0.719 W/kg
SAR(1 g) = 0.572 W/kg

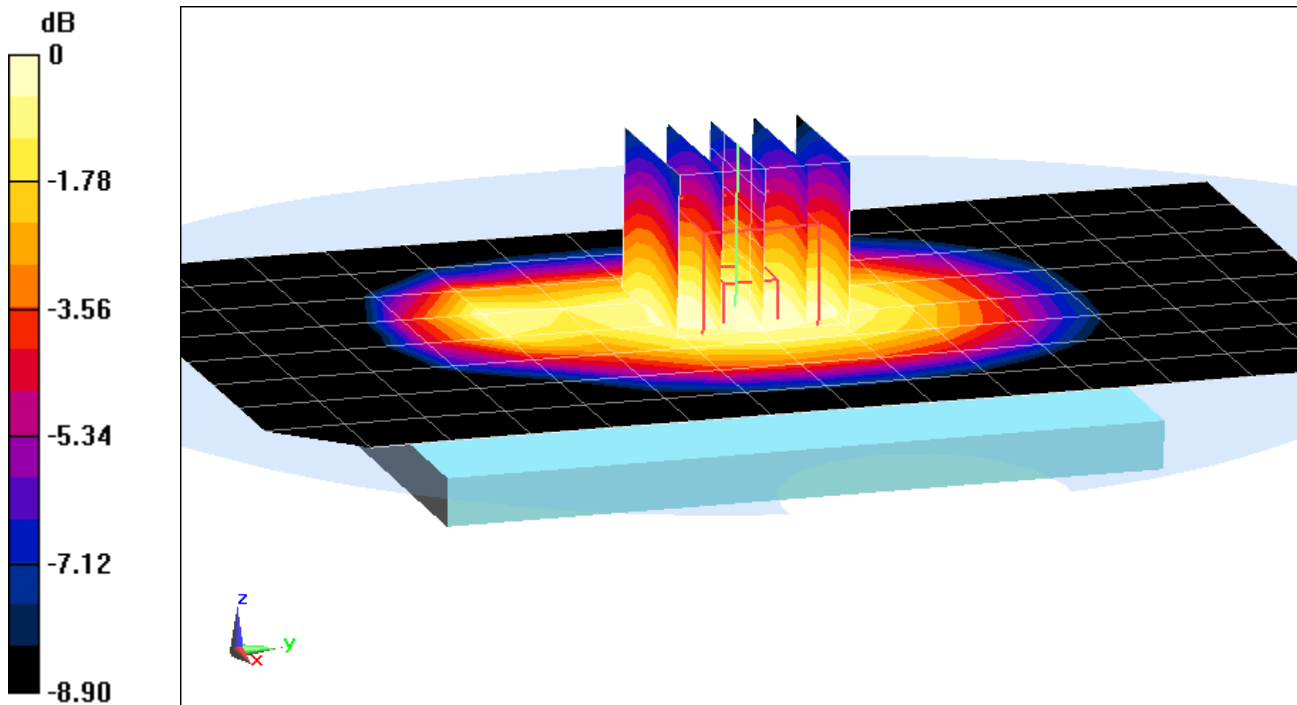

0 dB = 0.626 W/kg = -2.03 dBW/kg

PCTEST ENGINEERING LABORATORY, INC.

DUT: ZNFLS450; Type: Portable Handset; Serial: 06715

Communication System: UID 0, UMTS; Frequency: 1732.4 MHz; Duty Cycle: 1:1
Medium: 1750 Body Medium parameters used (interpolated):
 $f = 1732.4 \text{ MHz}$; $\sigma = 1.466 \text{ S/m}$; $\epsilon_r = 55.48$; $\rho = 1000 \text{ kg/m}^3$
Phantom section: Flat Section; Space: 1.0 cm

Test Date: 04-06-2016; Ambient Temp: 23.0°C; Tissue Temp: 22.6°C

Probe: ES3DV3 - SN3351; ConvF(4.88, 4.88, 4.88); Calibrated: 6/22/2015;
Sensor-Surface: 3mm (Mechanical Surface Detection)
Electronics: DAE4 Sn1322; Calibrated: 8/24/2015
Phantom: SAM V5.0 Right; Type: QD000P40CD; Serial: 1647
Measurement SW: DASY52, Version 52.8 (8); SEMCAD X Version 14.6.10 (7331)

Mode: UMTS 1750, Body SAR, Back side, Mid.ch

Area Scan (9x15x1): Measurement grid: dx=15mm, dy=15mm
Zoom Scan (6x5x7)/Cube 0: Measurement grid: dx=8mm, dy=8mm, dz=5mm
Reference Value = 26.93 V/m; Power Drift = -0.03 dB
Peak SAR (extrapolated) = 1.57 W/kg
SAR(1 g) = 0.986 W/kg

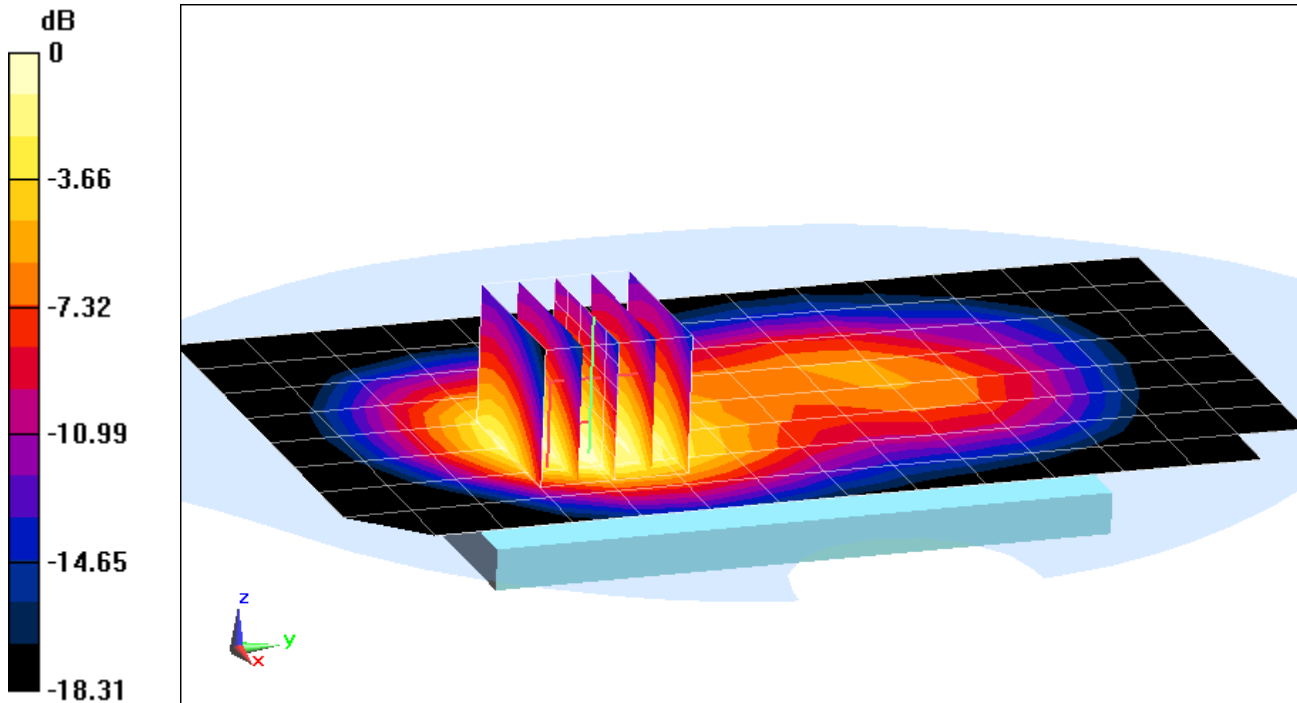

0 dB = 1.14 W/kg = 0.57 dBW/kg

PCTEST ENGINEERING LABORATORY, INC.

DUT: ZNFLS450; Type: Portable Handset; Serial: 06715

Communication System: UID 0, UMTS; Frequency: 1880 MHz; Duty Cycle: 1:1
Medium: 1900 Body Medium parameters used:
 $f = 1880 \text{ MHz}$; $\sigma = 1.504 \text{ S/m}$; $\epsilon_r = 51.5$; $\rho = 1000 \text{ kg/m}^3$
Phantom section: Flat Section; Space: 1.0 cm

Test Date: 04-05-2016; Ambient Temp: 23.1°C; Tissue Temp: 22.2°C

Probe: ES3DV3 - SN3334; ConvF(4.84, 4.84, 4.84); Calibrated: 11/17/2015;
Sensor-Surface: 3mm (Mechanical Surface Detection)
Electronics: DAE4 Sn1415; Calibrated: 11/11/2015
Phantom: SAM Front; Type: SAM; Serial: 1686
Measurement SW: DASY52, Version 52.8 (8); SEMCAD X Version 14.6.10 (7331)

Mode: UMTS 1900, Body SAR, Back side, Mid.ch

Area Scan (9x15x1): Measurement grid: dx=15mm, dy=15mm

Zoom Scan (5x5x7)/Cube 0: Measurement grid: dx=8mm, dy=8mm, dz=5mm

Reference Value = 23.45 V/m; Power Drift = 0.08 dB

Peak SAR (extrapolated) = 1.31 W/kg

SAR(1 g) = 0.773 W/kg

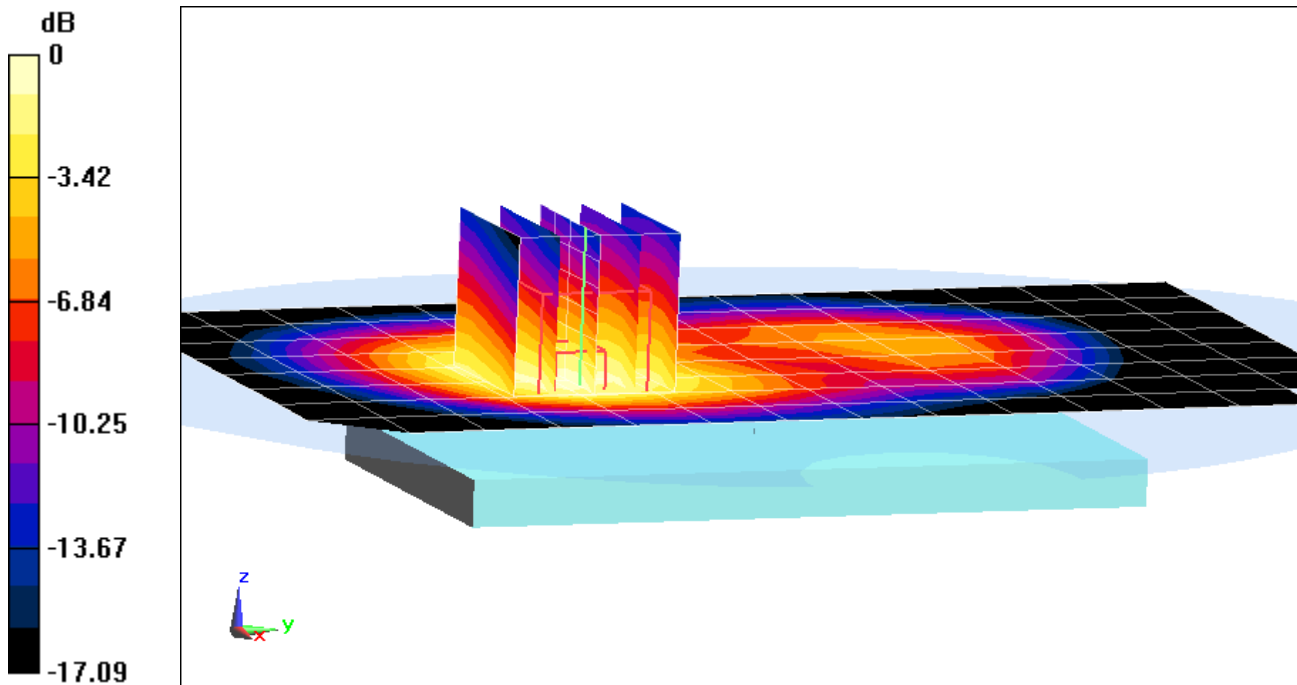

0 dB = 0.932 W/kg = -0.31 dBW/kg

PCTEST ENGINEERING LABORATORY, INC.

DUT: ZNFLS450; Type: Portable Handset; Serial: 06731

Communication System: UID 0, LTE Band 12; Frequency: 707.5 MHz; Duty Cycle: 1:1
Medium: 750 Body Medium parameters used (interpolated):
 $f = 707.5 \text{ MHz}$; $\sigma = 0.925 \text{ S/m}$; $\epsilon_r = 54.185$; $\rho = 1000 \text{ kg/m}^3$
Phantom section: Flat Section; Space: 1.0 cm

Test Date: 04-06-2016; Ambient Temp: 23.3°C; Tissue Temp: 23.3°C

Probe: ES3DV3 - SN3332; ConvF(6.36, 6.36, 6.36); Calibrated: 9/18/2015;
Sensor-Surface: 3mm (Mechanical Surface Detection)
Electronics: DAE4 Sn1466; Calibrated: 1/15/2016
Phantom: SAM Main ; Type: QD000P40CC; Serial: TP 1114
Measurement SW: DASY52, Version 52.8 (8); SEMCAD X Version 14.6.10 (7331)

Mode: LTE Band 12, Body SAR, Back side, Mid.ch
10 MHz Bandwidth, QPSK, 1 RB, 25 RB Offset

Area Scan (9x13x1): Measurement grid: $dx=15\text{mm}$, $dy=15\text{mm}$
Zoom Scan (5x6x7)/Cube 0: Measurement grid: $dx=8\text{mm}$, $dy=8\text{mm}$, $dz=5\text{mm}$
Reference Value = 21.71 V/m; Power Drift = -0.05 dB
Peak SAR (extrapolated) = 0.731 W/kg
SAR(1 g) = 0.447 W/kg

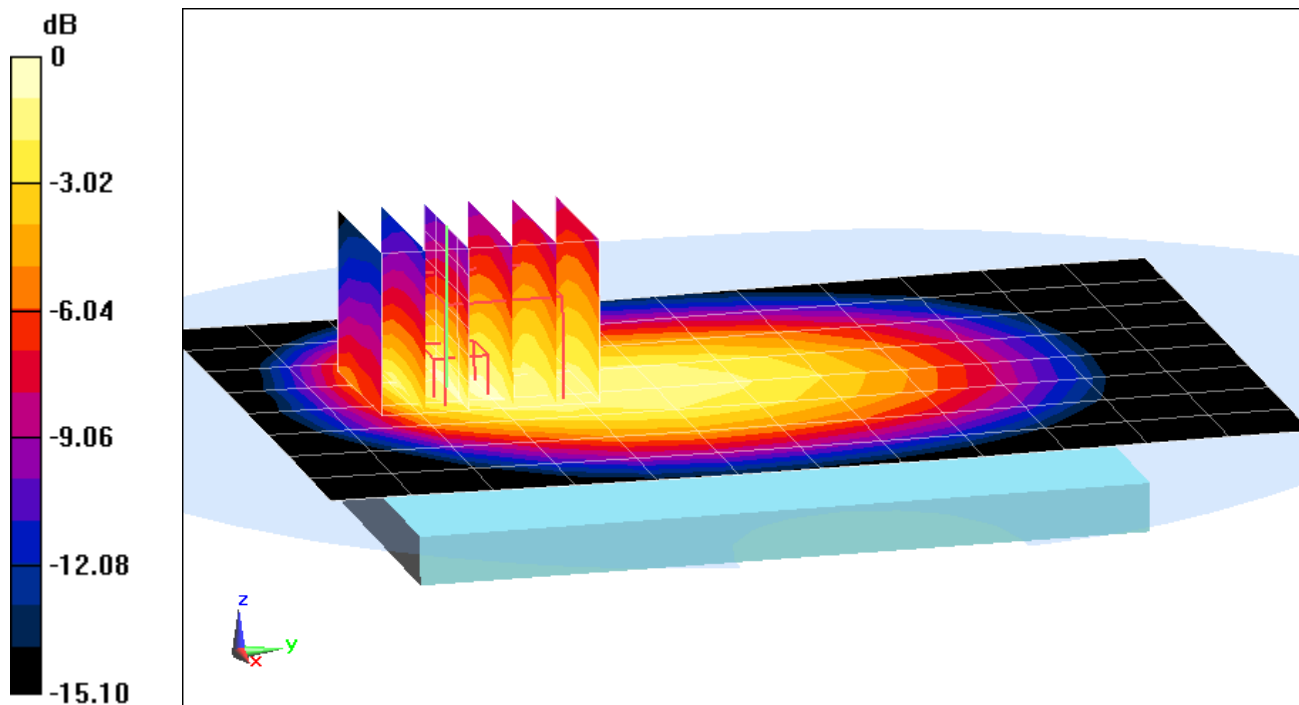

0 dB = 0.545 W/kg = -2.64 dBW/kg

PCTEST ENGINEERING LABORATORY, INC.

DUT: ZNFLS450; Type: Portable Handset; Serial: 06731

Communication System: UID 0, LTE Band 26 (0); Frequency: 836.5 MHz; Duty Cycle: 1:1
Medium: 835 Body Medium parameters used (interpolated):
 $f = 836.5 \text{ MHz}$; $\sigma = 0.98 \text{ S/m}$; $\epsilon_r = 53.041$; $\rho = 1000 \text{ kg/m}^3$
Phantom section: Flat Section; Space: 1.0 cm

Test Date: 04-07-2016; Ambient Temp: 23.2°C; Tissue Temp: 22.7°C

Probe: ES3DV3 - SN3318; ConvF(6.11, 6.11, 6.11); Calibrated: 2/19/2016;
Sensor-Surface: 3mm (Mechanical Surface Detection)
Electronics: DAE4 Sn665; Calibrated: 2/19/2016
Phantom: SAM with CRP v4.0; Type: QD000P40CD; Serial: TP:1800
Measurement SW: DASY52, Version 52.8 (8); SEMCAD X Version 14.6.10 (7331)

Mode: LTE Band 26 (Cell.), Body SAR, Back side, Mid.ch
15 MHz Bandwidth, QPSK, 1 RB, 74 RB Offset

Area Scan (8x13x1): Measurement grid: $dx=15\text{mm}$, $dy=15\text{mm}$
Zoom Scan (5x5x7)/Cube 0: Measurement grid: $dx=8\text{mm}$, $dy=8\text{mm}$, $dz=5\text{mm}$
Reference Value = 27.20 V/m; Power Drift = 0.14 dB
Peak SAR (extrapolated) = 0.900 W/kg
SAR(1 g) = 0.707 W/kg

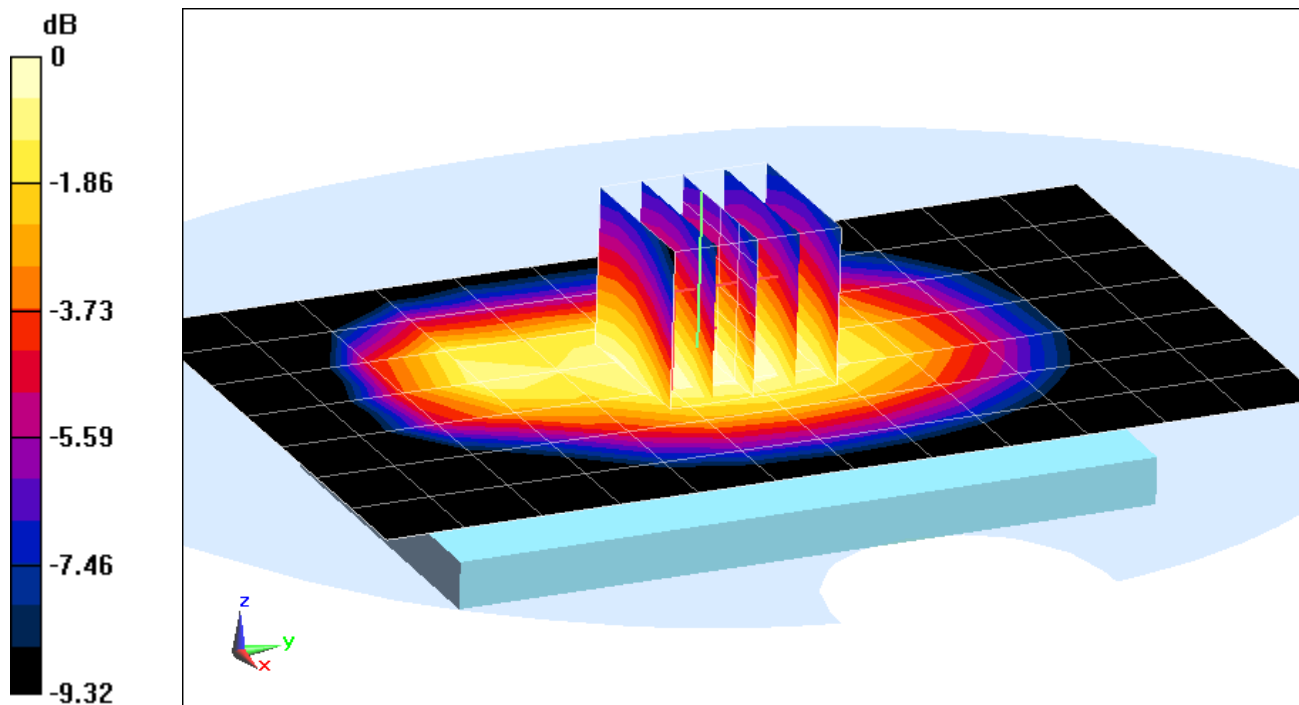

0 dB = 0.775 W/kg = -1.11 dBW/kg

PCTEST ENGINEERING LABORATORY, INC.

DUT: ZNFLS450; Type: Portable Handset; Serial: 06731

Communication System: UID 0, LTE Band 4 (AWS); Frequency: 1732.5 MHz; Duty Cycle: 1:1
Medium: 1750 Body Medium parameters used (interpolated):
 $f = 1732.5 \text{ MHz}$; $\sigma = 1.466 \text{ S/m}$; $\epsilon_r = 55.479$; $\rho = 1000 \text{ kg/m}^3$
Phantom section: Flat Section; Space: 1.0 cm

Test Date: 04-06-2016; Ambient Temp: 23.0°C; Tissue Temp: 22.6°C

Probe: ES3DV3 - SN3351; ConvF(4.88, 4.88, 4.88); Calibrated: 6/22/2015;
Sensor-Surface: 3mm (Mechanical Surface Detection)
Electronics: DAE4 Sn1322; Calibrated: 8/24/2015
Phantom: SAM V5.0 Right; Type: QD000P40CD; Serial: 1647
Measurement SW: DASY52, Version 52.8 (8); SEMCAD X Version 14.6.10 (7331)

Mode: LTE Band 4 (AWS), Body SAR, Back side, Mid.ch
20 MHz Bandwidth, QPSK, 1 RB, 50 RB Offset

Area Scan (9x13x1): Measurement grid: $dx=15\text{mm}$, $dy=15\text{mm}$
Zoom Scan (5x5x7)/Cube 0: Measurement grid: $dx=8\text{mm}$, $dy=8\text{mm}$, $dz=5\text{mm}$
Reference Value = 26.35 V/m; Power Drift = 0.12 dB
Peak SAR (extrapolated) = 1.47 W/kg
SAR(1 g) = 0.935 W/kg

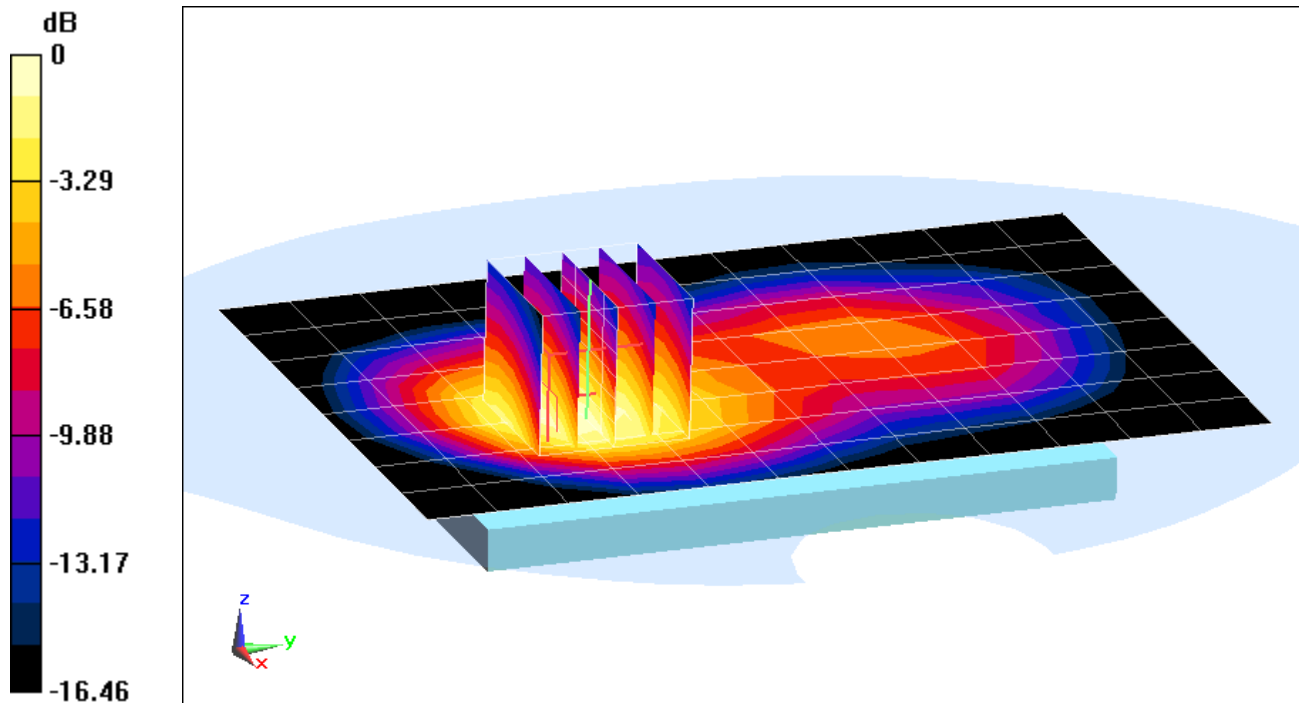

0 dB = 1.09 W/kg = 0.37 dBW/kg

PCTEST ENGINEERING LABORATORY, INC.

DUT: ZNFLS450; Type: Portable Handset; Serial: 06731

Communication System: UID 0, LTE Band 25 (PCS); Frequency: 1882.5 MHz; Duty Cycle: 1:1
Medium: 1900 Body Medium parameters used (interpolated):
 $f = 1882.5 \text{ MHz}$; $\sigma = 1.507 \text{ S/m}$; $\epsilon_r = 51.491$; $\rho = 1000 \text{ kg/m}^3$
Phantom section: Flat Section; Space: 1.0 cm

Test Date: 04-05-2016; Ambient Temp: 23.1°C; Tissue Temp: 22.2°C

Probe: ES3DV3 - SN3334; ConvF(4.84, 4.84, 4.84); Calibrated: 11/17/2015;
Sensor-Surface: 3mm (Mechanical Surface Detection)
Electronics: DAE4 Sn1415; Calibrated: 11/11/2015
Phantom: SAM Front; Type: SAM; Serial: 1686
Measurement SW: DASY52, Version 52.8 (8); SEMCAD X Version 14.6.10 (7331)

Mode: LTE Band 25 (PCS), Body SAR, Back side, Mid.ch
20 MHz Bandwidth, QPSK, 1 RB, 50 RB Offset

Area Scan (9x15x1): Measurement grid: $dx=15\text{mm}$, $dy=15\text{mm}$
Zoom Scan (6x6x7)/Cube 0: Measurement grid: $dx=8\text{mm}$, $dy=8\text{mm}$, $dz=5\text{mm}$
Reference Value = 20.41 V/m; Power Drift = 0.09 dB
Peak SAR (extrapolated) = 0.971 W/kg
SAR(1 g) = 0.582 W/kg

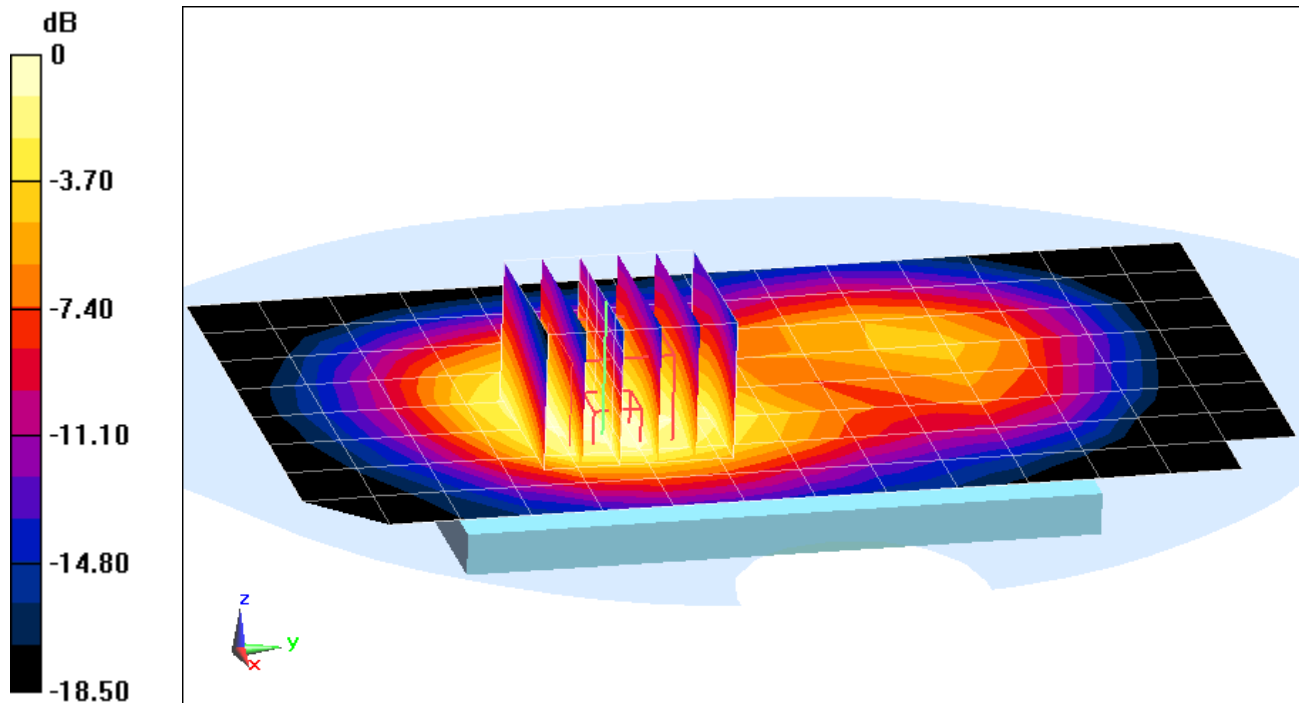

0 dB = 0.702 W/kg = -1.54 dBW/kg

PCTEST ENGINEERING LABORATORY, INC.

DUT: ZNFLS450; Type: Portable Handset; Serial: 06731

Communication System: UID 0, LTE Band 41 (0); Frequency: 2680 MHz; Duty Cycle: 1:1.59
Medium: 2450 Body Medium parameters used (interpolated):
 $f = 2680 \text{ MHz}$; $\sigma = 2.277 \text{ S/m}$; $\epsilon_r = 50.034$; $\rho = 1000 \text{ kg/m}^3$
Phantom section: Flat Section; Space: 1.0 cm

Test Date: 04-11-2016; Ambient Temp: 24.0°C; Tissue Temp: 23.4°C

Probe: ES3DV2 - SN3022; ConvF(3.96, 3.96, 3.96); Calibrated: 8/26/2015;
Sensor-Surface: 3mm (Mechanical Surface Detection)
Electronics: DAE4 Sn1323; Calibrated: 9/16/2015
Phantom: SAM Left; Type: QD000P40CC; Serial: TP: 1375
Measurement SW: DASY52, Version 52.8 (8); SEMCAD X Version 14.6.10 (7331)

Mode: LTE Band 41, Body SAR, Back side, High.ch
20 MHz Bandwidth, QPSK, 1 RB, 0 RB Offset

Area Scan (10x16x1): Measurement grid: dx=12mm, dy=12mm
Zoom Scan (7x7x7)/Cube 0: Measurement grid: dx=5mm, dy=5mm, dz=5mm
Reference Value = 13.53 V/m; Power Drift = -0.06 dB
Peak SAR (extrapolated) = 0.733 W/kg
SAR(1 g) = 0.371 W/kg

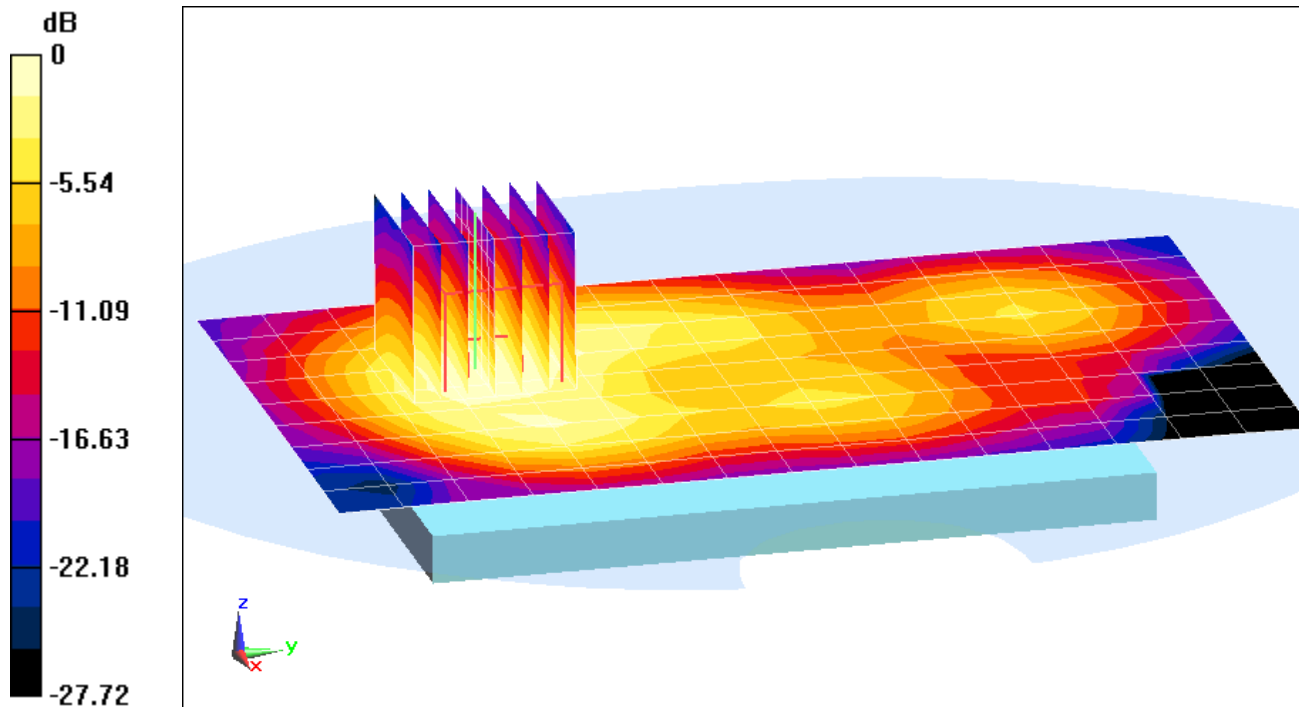

0 dB = 0.459 W/kg = -3.38 dBW/kg

PCTEST ENGINEERING LABORATORY, INC.

DUT: ZNFLS450; Type: Portable Handset; Serial: 06723

Communication System: UID 0, IEEE 802.11b (0); Frequency: 2437 MHz; Duty Cycle: 1:1
Medium: 2450 Body Medium parameters used (interpolated):
 $f = 2437 \text{ MHz}$; $\sigma = 2.005 \text{ S/m}$; $\epsilon_r = 51.858$; $\rho = 1000 \text{ kg/m}^3$
Phantom section: Flat Section; Space: 1.0 cm

Test Date: 04-09-2016; Ambient Temp: 22.6°C; Tissue Temp: 22.3°C

Probe: ES3DV3 - SN3334; ConvF(4.45, 4.45, 4.45); Calibrated: 11/17/2015;
Sensor-Surface: 3mm (Mechanical Surface Detection)
Electronics: DAE4 Sn1415; Calibrated: 11/11/2015
Phantom: SAM Front; Type: SAM; Serial: 1686

Measurement SW: DASY52, Version 52.8 (8); SEMCAD X Version 14.6.10 (7331)

Mode: IEEE 802.11b, 22 MHz Bandwidth, Body SAR, Ch 06, 1 Mbps, Back Side

Area Scan (10x16x1): Measurement grid: dx=12mm, dy=12mm

Zoom Scan (7x7x7)/Cube 0: Measurement grid: dx=5mm, dy=5mm, dz=5mm

Reference Value = 8.203 V/m; Power Drift = 0.05 dB

Peak SAR (extrapolated) = 0.246 W/kg

SAR(1 g) = 0.118 W/kg

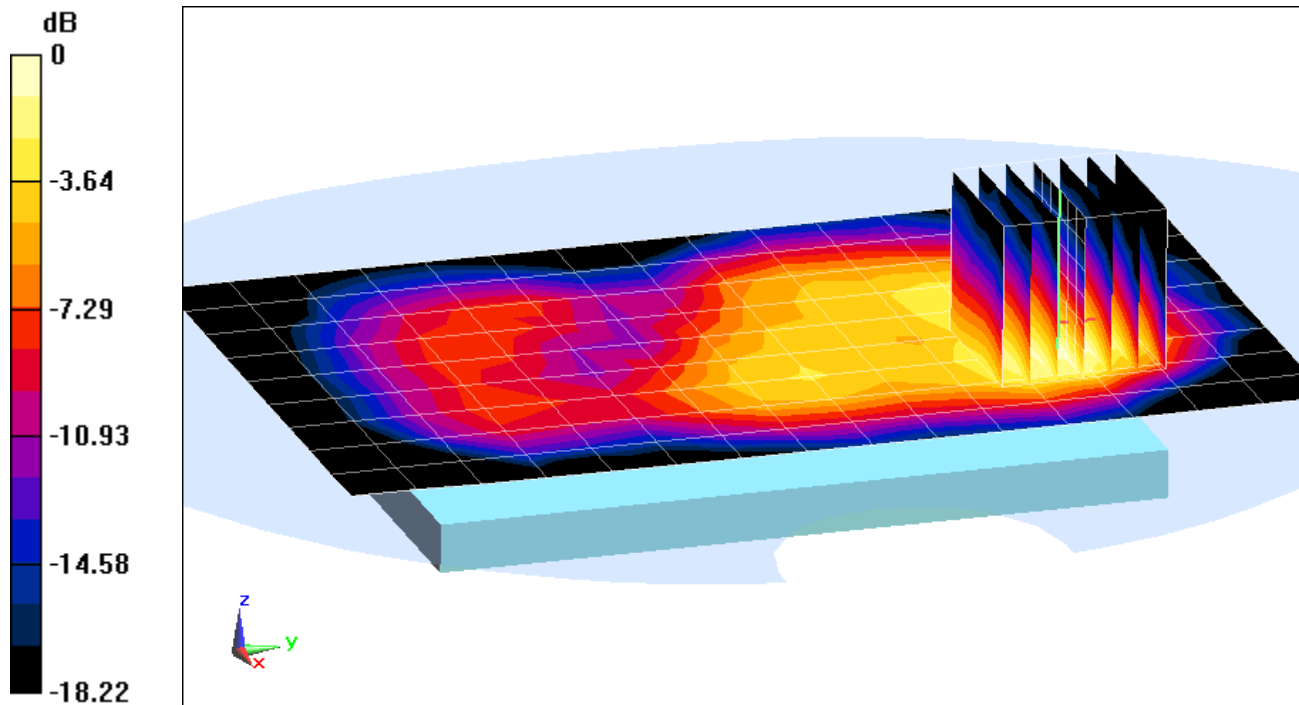

0 dB = 0.152 W/kg = -8.18 dBW/kg

APPENDIX B: SYSTEM VERIFICATION

PCTEST ENGINEERING LABORATORY, INC.

DUT: Dipole 750 MHz; Type: D750V3; Serial: 1054

Communication System: UID 0, CW; Frequency: 750 MHz; Duty Cycle: 1:1

Medium: 750 Head Medium parameters used (interpolated):

$f = 750 \text{ MHz}$; $\sigma = 0.903 \text{ S/m}$; $\epsilon_r = 42.698$; $\rho = 1000 \text{ kg/m}^3$

Phantom section: Flat Section ; Space: 1.5 cm

Test Date: 04-06-2016; Ambient Temp: 23.4°C; Tissue Temp: 23.0°C

Probe: ES3DV3 - SN3333; ConvF(6.46, 6.46, 6.46); Calibrated: 10/29/2015;

Sensor-Surface: 3mm (Mechanical Surface Detection)

Electronics: DAE4 Sn1333; Calibrated: 10/27/2015

Phantom: SAM Front; Type: QD000P40CD; Serial: TP:1758

Measurement SW: DASY52, Version 52.8 (8);SEMCAD X Version 14.6.10 (7331)

750 MHz System Verification at 23.0 dBm (200 mW)

Area Scan (7x15x1): Measurement grid: dx=15mm, dy=15mm

Zoom Scan (5x5x7)/Cube 0: Measurement grid: dx=8mm, dy=8mm, dz=5mm

Peak SAR (extrapolated) = 2.40 W/kg

SAR(1 g) = 1.62 W/kg;

Deviation(1 g) = -1.46%

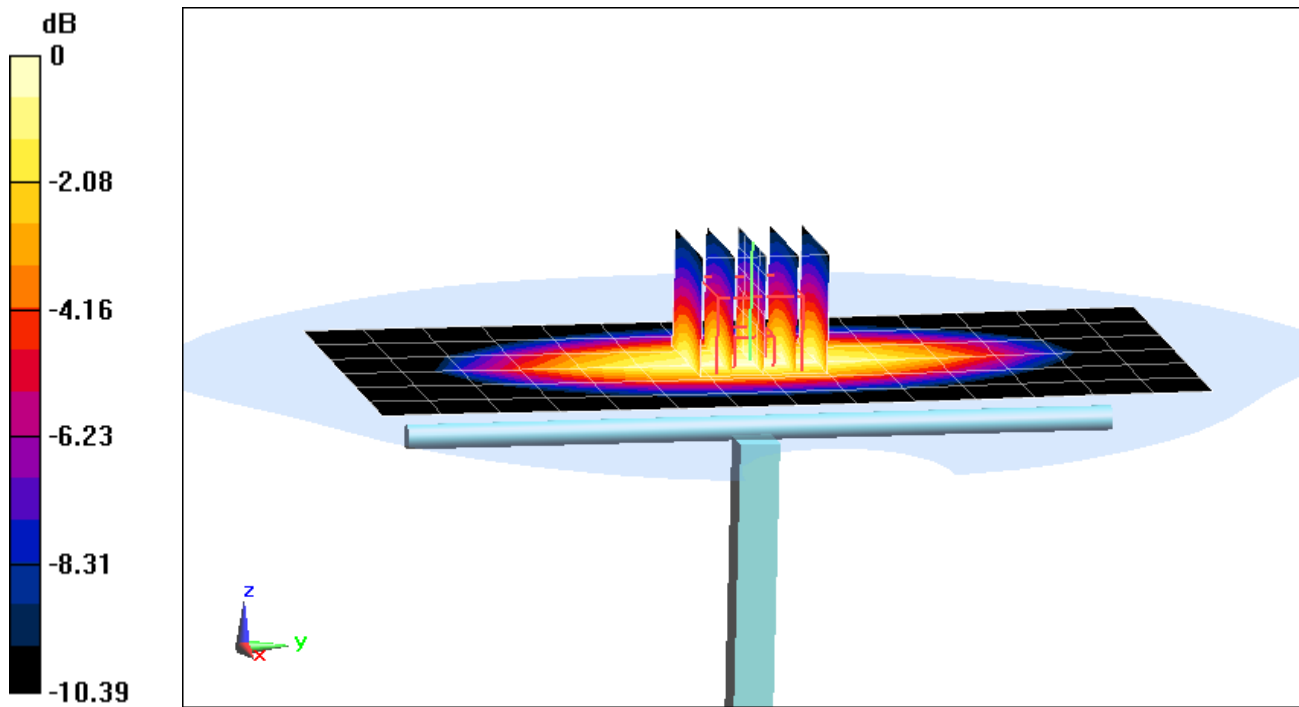

0 dB = 1.90 W/kg = 2.79 dBW/kg

PCTEST ENGINEERING LABORATORY, INC.

DUT: Dipole 835 MHz; Type: D835V2; Serial: 4d133

Communication System: UID 0, CW; Frequency: 835 MHz; Duty Cycle: 1:1

Medium: 835 Head Medium parameters used:

$f = 835 \text{ MHz}$; $\sigma = 0.914 \text{ S/m}$; $\epsilon_r = 42.395$; $\rho = 1000 \text{ kg/m}^3$

Phantom section: Flat Section; Space: 1.5 cm

Test Date: 04-07-2016; Ambient Temp: 24.0°C; Tissue Temp: 22.5°C

Probe: ES3DV2 - SN3022; ConvF(6.11, 6.11, 6.11); Calibrated: 8/26/2015;

Sensor-Surface: 3mm (Mechanical Surface Detection)

Electronics: DAE4 Sn1323; Calibrated: 9/16/2015

Phantom: SAM Right; Type: QD000P40CD; Serial: TP:7535

Measurement SW: DASY52, Version 52.8 (8); SEMCAD X Version 14.6.10 (7331)

835 MHz System Verification at 23.0 dBm (200 mW)

Area Scan (7x14x1): Measurement grid: dx=15mm, dy=15mm

Zoom Scan (5x5x7)/Cube 0: Measurement grid: dx=8mm, dy=8mm, dz=5mm

Peak SAR (extrapolated) = 2.90 W/kg

SAR(1 g) = 1.96 W/kg

Deviation(1 g) = 7.34%

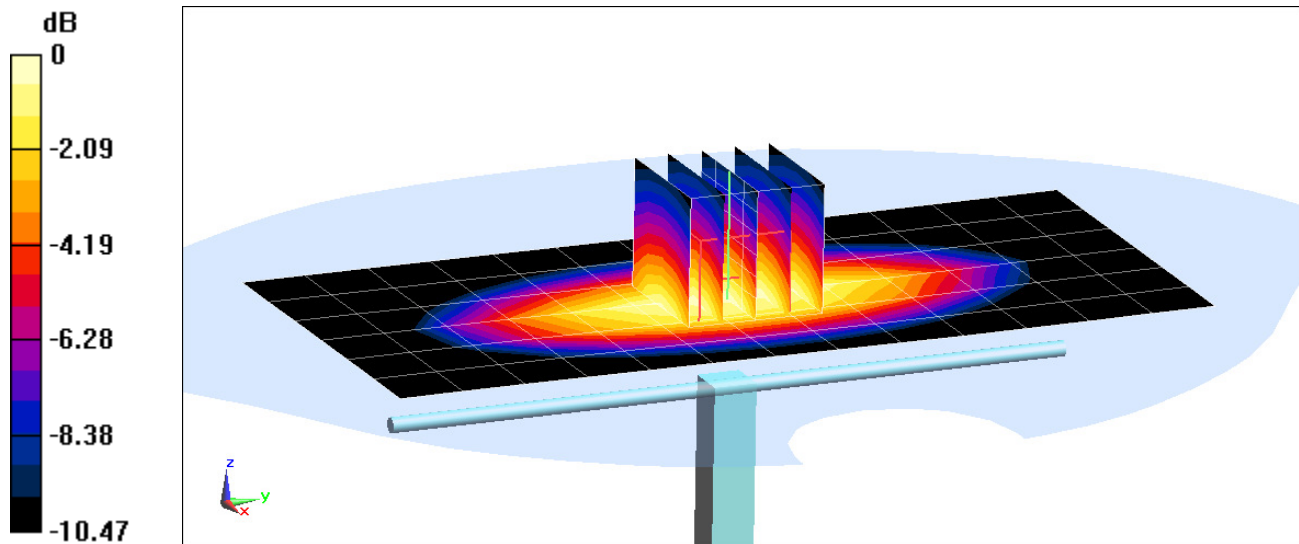

0 dB = 2.30 W/kg = 3.62 dBW/kg

PCTEST ENGINEERING LABORATORY, INC.

DUT: Dipole 835 MHz; Type: D835V2; Serial: 4d132

Communication System: UID 0, CW; Frequency: 835 MHz; Duty Cycle: 1:1

Medium: 835 Head Medium parameters used:

$f = 835 \text{ MHz}$; $\sigma = 0.896 \text{ S/m}$; $\epsilon_r = 40.044$; $\rho = 1000 \text{ kg/m}^3$

Phantom section: Flat Section; Space: 1.5 cm

Test Date: 04-08-2016; Ambient Temp: 23.5°C; Tissue Temp: 22.0°C

Probe: ES3DV3 - SN3288; ConvF(6.41, 6.41, 6.41); Calibrated: 9/18/2015;

Sensor-Surface: 3mm (Mechanical Surface Detection)

Electronics: DAE4 Sn1364; Calibrated: 9/18/2015

Phantom: Main TWIN SAM; Type: QD000P40CC; Serial: TP-1406

Measurement SW: DASY52, Version 52.8 (8);SEMCAD X Version 14.6.10 (7331)

835 MHz System Verification at 23.0 dBm (200 mW)

Area Scan (7x14x1): Measurement grid: dx=15mm, dy=15mm

Zoom Scan (5x5x7)/Cube 0: Measurement grid: dx=8mm, dy=8mm, dz=5mm

Peak SAR (extrapolated) = 2.90 W/kg

SAR(1 g) = 1.93 W/kg

Deviation(1 g) = 1.90%

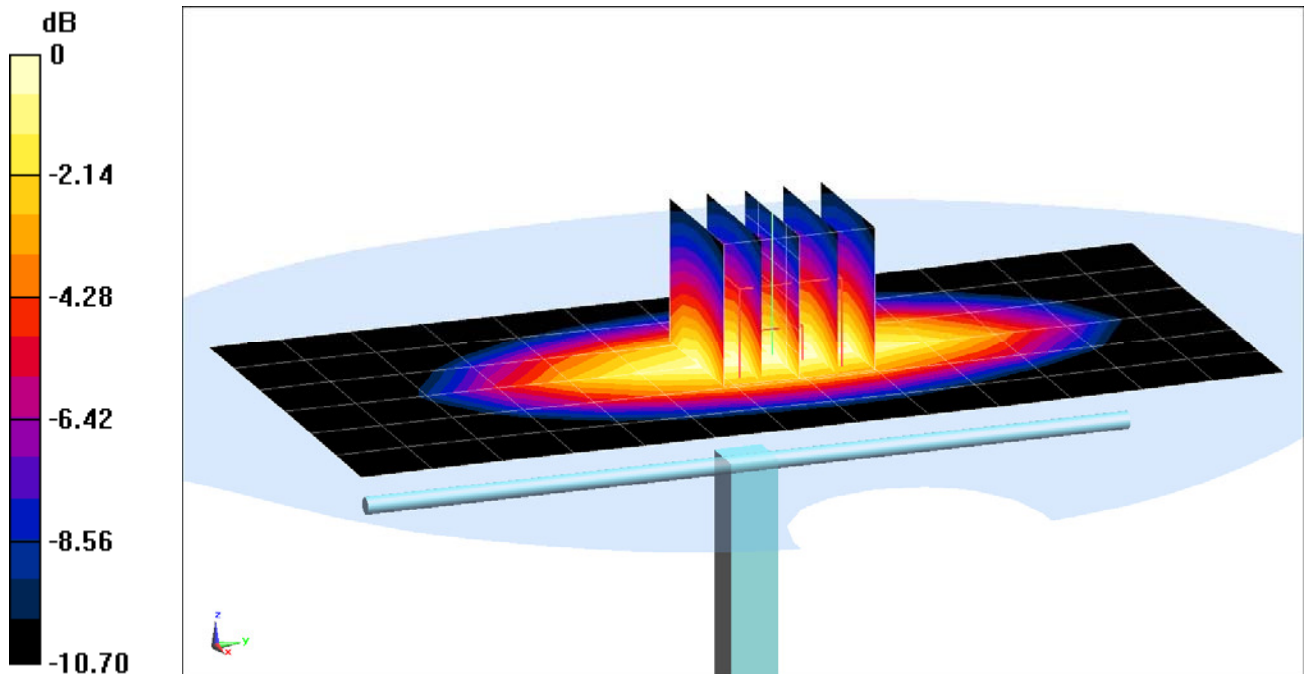

0 dB = 2.28 W/kg = 3.58 dBW/kg

PCTEST ENGINEERING LABORATORY, INC.

DUT: Dipole 1750 MHz; Type: D1750V2; Serial: 1051

Communication System: UID 0, CW; Frequency: 1750 MHz; Duty Cycle: 1:1

Medium: 1750 Head Medium parameters used:

$f = 1750 \text{ MHz}$; $\sigma = 1.332 \text{ S/m}$; $\epsilon_r = 39.398$; $\rho = 1000 \text{ kg/m}^3$

Phantom section: Flat Section; Space: 1.0 cm

Test Date: 04-07-2016; Ambient Temp: 23.0°C; Tissue Temp: 23.2°C

Probe: ES3DV2 - SN3022; ConvF(5.08, 5.08, 5.08); Calibrated: 8/26/2015;

Sensor-Surface: 3mm (Mechanical Surface Detection)

Electronics: DAE4 Sn1323; Calibrated: 9/16/2015

Phantom: SAM Right; Type: QD000P40CD; Serial: TP:7535

Measurement SW: DASY52, Version 52.8 (8); SEMCAD X Version 14.6.10 (7331)

1750 MHz System Verification at 20.0 dBm (100 mW)

Area Scan (7x9x1): Measurement grid: dx=15mm, dy=15mm

Zoom Scan (5x6x7)/Cube 0: Measurement grid: dx=8mm, dy=8mm, dz=5mm

Peak SAR (extrapolated) = 6.35 W/kg

SAR(1 g) = 3.57 W/kg

Deviation(1 g) = -1.38%

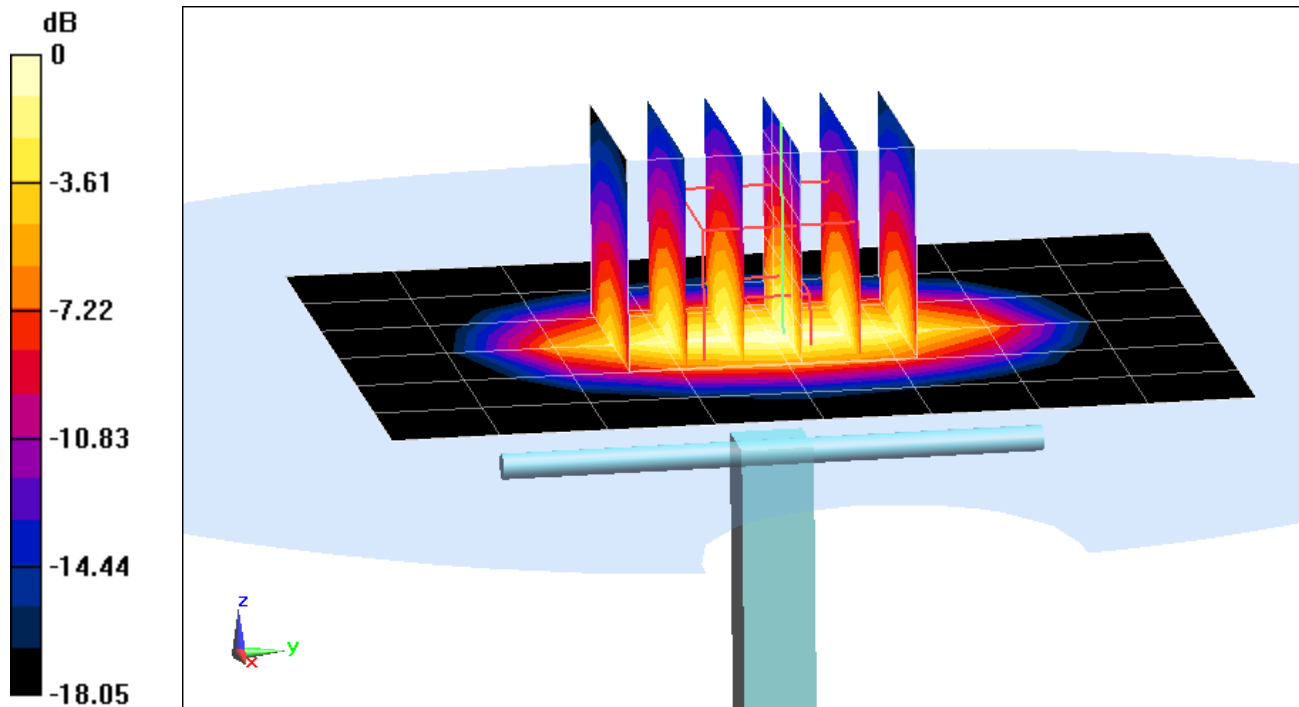

0 dB = 4.46 W/kg = 6.49 dBW/kg

PCTEST ENGINEERING LABORATORY, INC.

DUT: Dipole 1900 MHz; Type: D1900V2; Serial: 5d149

Communication System: UID 0, CW; Frequency: 1900 MHz; Duty Cycle: 1:1

Medium: 1900 Head Medium parameters used (interpolated):

$f = 1900 \text{ MHz}$; $\sigma = 1.43 \text{ S/m}$; $\epsilon_r = 39.38$; $\rho = 1000 \text{ kg/m}^3$

Phantom section: Flat Section; Space: 1.0 cm

Test Date: 04-07-2016; Ambient Temp: 23.5°C; Tissue Temp: 22.5°C

Probe: ES3DV3 - SN3213; ConvF(5.05, 5.05, 5.05); Calibrated: 2/19/2016;

Sensor-Surface: 3mm (Mechanical Surface Detection)

Electronics: DAE4 Sn1272; Calibrated: 2/18/2016

Phantom: SAM v5.0 front; Type: QD000P40CD; Serial: TP-1646

Measurement SW: DASY52, Version 52.8 (8); SEMCAD X Version 14.6.10 (7331)

1900 MHz System Verification at 20.0 dBm (100 mW)

Area Scan (7x10x1): Measurement grid: dx=15mm, dy=15mm

Zoom Scan (5x5x7)/Cube 0: Measurement grid: dx=8mm, dy=8mm, dz=5mm

Peak SAR (extrapolated) = 7.56 W/kg

SAR(1 g) = 4.08 W/kg

Deviation(1 g) = 0.25%

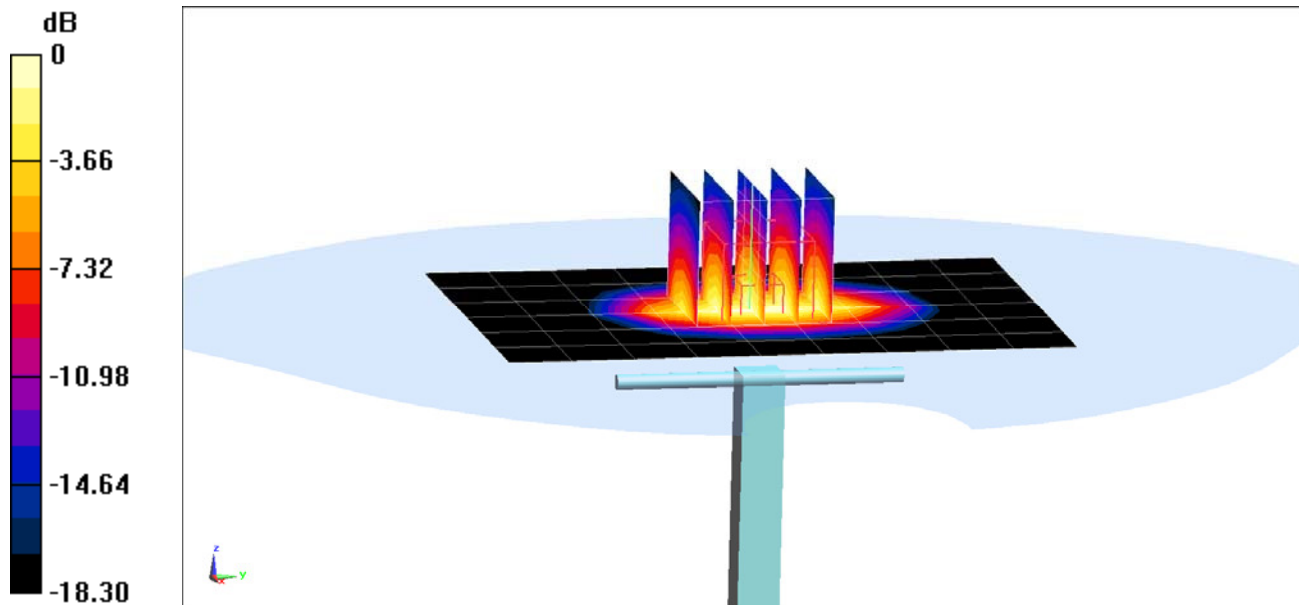

0 dB = 5.17 W/kg = 7.13 dBW/kg

PCTEST ENGINEERING LABORATORY, INC.

DUT: Dipole 1900 MHz; Type: D1900V2; Serial: 5d148

Communication System: UID 0, CW; Frequency: 1900 MHz; Duty Cycle: 1:1
Medium: 1900 Head Medium parameters used (interpolated):
 $f = 1900 \text{ MHz}$; $\sigma = 1.457 \text{ S/m}$; $\epsilon_r = 40.196$; $\rho = 1000 \text{ kg/m}^3$
Phantom section: Flat Section; Space: 1.0 cm

Test Date: 04-11-2016; Ambient Temp: 23.5°C; Tissue Temp: 22.0°C

Probe: ES3DV3 - SN3332; ConvF(5.06, 5.06, 5.06); Calibrated: 9/18/2015;
Sensor-Surface: 3mm (Mechanical Surface Detection)
Electronics: DAE4 Sn1466; Calibrated: 1/15/2016
Phantom: SAM Main ; Type: QD000P40CC; Serial: TP 1114
Measurement SW: DASY52, Version 52.8 (8);SEMCAD X Version 14.6.10 (7331)

1900 MHz System Verification at 20.0 dBm (100 mW)

Area Scan (7x10x1): Measurement grid: dx=15mm, dy=15mm
Zoom Scan (5x5x7)/Cube 0: Measurement grid: dx=8mm, dy=8mm, dz=5mm
Peak SAR (extrapolated) = 7.12 W/kg
SAR(1 g) = 3.84 W/kg
Deviation(1 g) = -3.76%

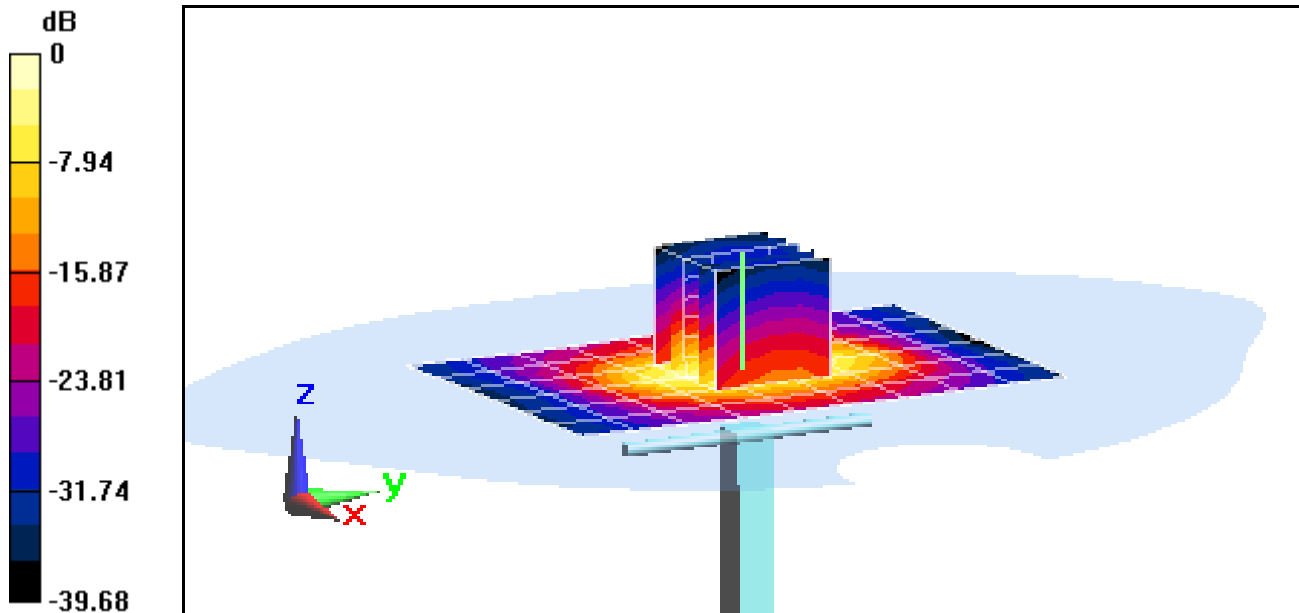

0 dB = 4.80 W/kg = 6.81 dBW/kg

PCTEST ENGINEERING LABORATORY, INC.

DUT: Dipole 2450 MHz; Type: D2450V2; Serial: 882

Communication System: UID 0, CW; Frequency: 2450 MHz; Duty Cycle: 1:1

Medium: 2450 Head Medium parameters used:

$f = 2450 \text{ MHz}$; $\sigma = 1.875 \text{ S/m}$; $\epsilon_r = 37.827$; $\rho = 1000 \text{ kg/m}^3$

Phantom section: Flat Section; Space: 1.0 cm

Test Date: 04-09-2016; Ambient Temp: 20.1°C; Tissue Temp: 21.9°C

Probe: ES3DV3 - SN3318; ConvF(4.57, 4.57, 4.57); Calibrated: 2/19/2016;

Sensor-Surface: 3mm (Mechanical Surface Detection)

Electronics: DAE4 Sn665; Calibrated: 2/19/2016

Phantom: SAM with CRP v4.0; Type: QD000P40CD; Serial: TP:1800

Measurement SW: DASY52, Version 52.8 (8);SEMCAD X Version 14.6.10 (7331)

2450 MHz System Verification at 20.0 dBm (100 mW)

Area Scan (8x9x1): Measurement grid: dx=12mm, dy=12mm

Zoom Scan (7x7x7)/Cube 0: Measurement grid: dx=5mm, dy=5mm, dz=5mm

Peak SAR (extrapolated) = 10.7 W/kg

SAR(1 g) = 5.05 W/kg

Deviation(1 g) = 0.00%

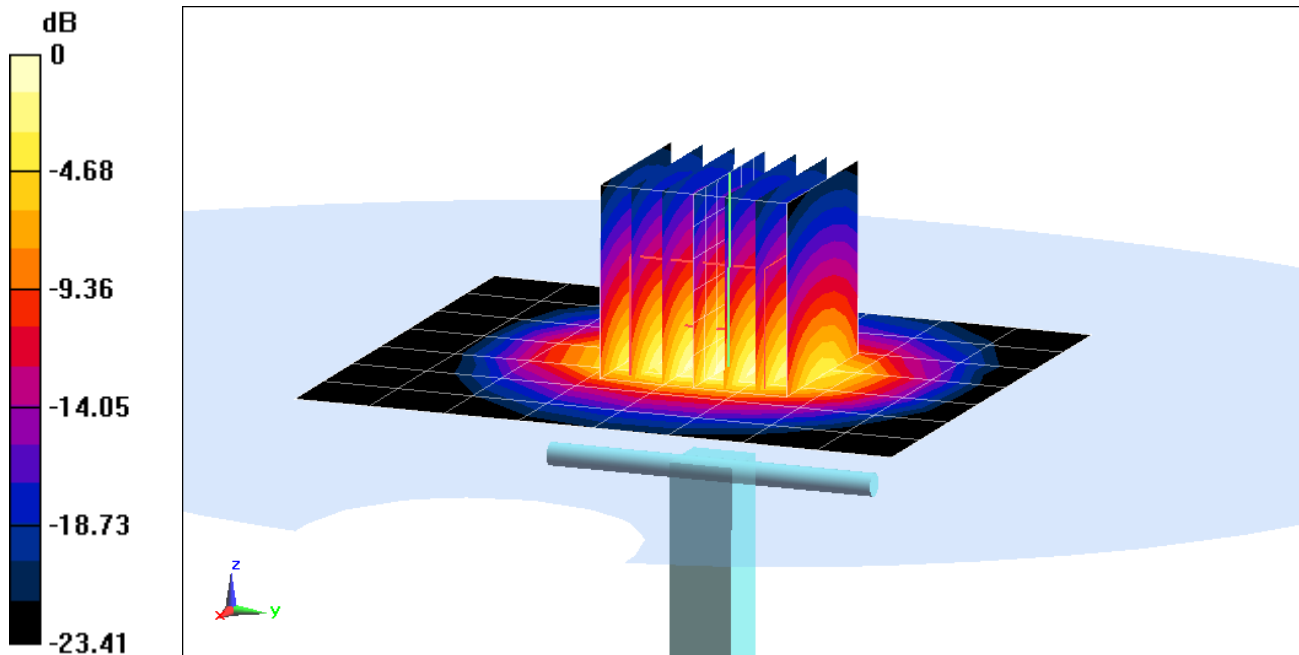

0 dB = 6.74 W/kg = 8.29 dBW/kg

PCTEST ENGINEERING LABORATORY, INC.

DUT: Dipole 2600 MHz; Type: D2600V2; Serial: 1071

Communication System: UID 0, CW; Frequency: 2600 MHz; Duty Cycle: 1:1

Medium: 2450 Head Medium parameters used:

$f = 2600$ MHz; $\sigma = 2.022$ S/m; $\epsilon_r = 39.029$; $\rho = 1000$ kg/m³

Phantom section: Flat Section; Space: 1.0 cm

Test Date: 04-11-2016; Ambient Temp: 22.7°C; Tissue Temp: 23.0°C

Probe: ES3DV3 - SN3319; ConvF(4.33, 4.33, 4.33); Calibrated: 3/18/2016;

Sensor-Surface: 3mm (Mechanical Surface Detection)

Electronics: DAE4 Sn1368; Calibrated: 3/14/2016

Phantom: SAM with CRP v5.0 (Right); Type: QD000P40CD; Serial: TP:1759

Measurement SW: DASY52, Version 52.8 (8);SEMCAD X Version 14.6.10 (7331)

2600 MHz System Verification at 20.0 dBm (100 mW)

Area Scan (8x9x1): Measurement grid: dx=12mm, dy=12mm

Zoom Scan (7x7x7)/Cube 0: Measurement grid: dx=5mm, dy=5mm, dz=5mm

Peak SAR (extrapolated) = 12.4 W/kg

SAR(1 g) = 5.54 W/kg

Deviation(1 g) = -0.89%

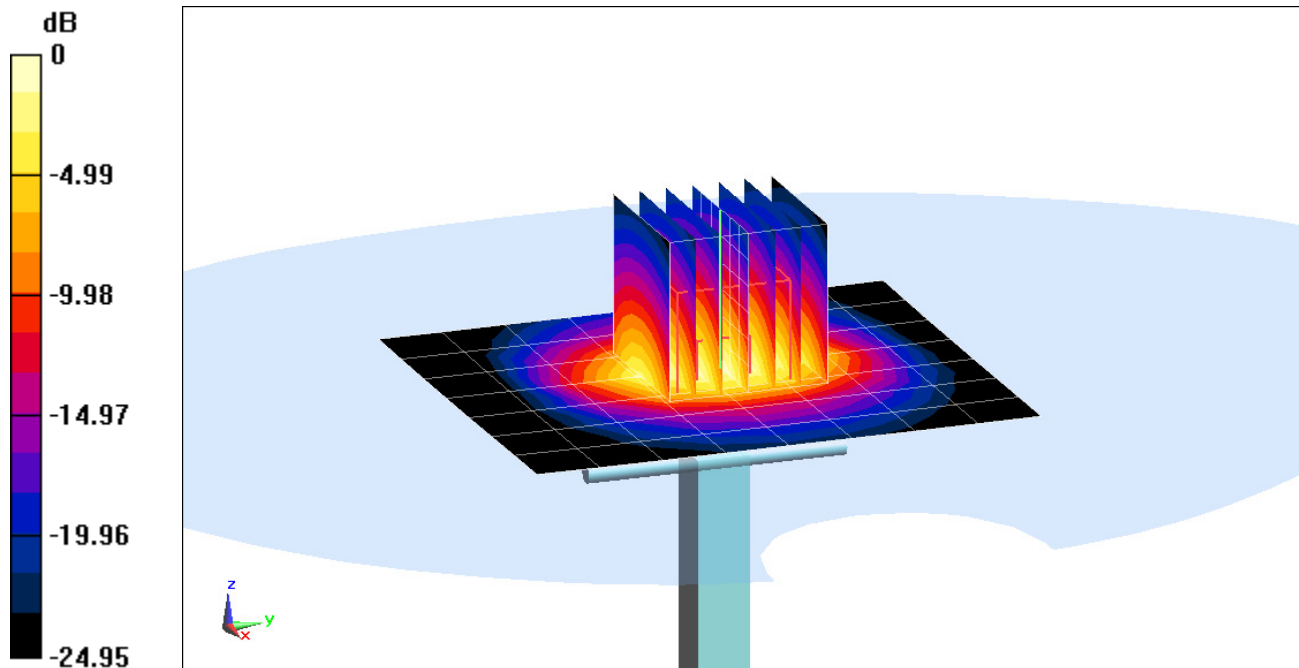

0 dB = 7.45 W/kg = 8.72 dBW/kg

PCTEST ENGINEERING LABORATORY, INC.

DUT: Dipole 750 MHz; Type: D750V3; Serial: 1003

Communication System: UID 0, CW; Frequency: 750 MHz; Duty Cycle: 1:1
Medium: 750 Body Medium parameters used (interpolated):
 $f = 750 \text{ MHz}$; $\sigma = 0.961 \text{ S/m}$; $\epsilon_r = 53.81$; $\rho = 1000 \text{ kg/m}^3$
Phantom section: Flat Section; Space: 1.5 cm

Test Date: 04-06-2016; Ambient Temp: 23.3°C; Tissue Temp: 23.3°C

Probe: ES3DV3 - SN3332; ConvF(6.36, 6.36, 6.36); Calibrated: 9/18/2015;
Sensor-Surface: 3mm (Mechanical Surface Detection)
Electronics: DAE4 Sn1466; Calibrated: 1/15/2016
Phantom: SAM Main ; Type: QD000P40CC; Serial: TP 1114
Measurement SW: DASY52, Version 52.8 (8);SEMCAD X Version 14.6.10 (7331)

750 MHz System Verification at 23.0 dBm (200 mW)

Area Scan (7x15x1): Measurement grid: dx=15mm, dy=15mm
Zoom Scan (5x5x7)/Cube 0: Measurement grid: dx=8mm, dy=8mm, dz=5mm
Peak SAR (extrapolated) = 2.57 W/kg
SAR(1 g) = 1.77 W/kg
Deviation(1 g) = 2.19%

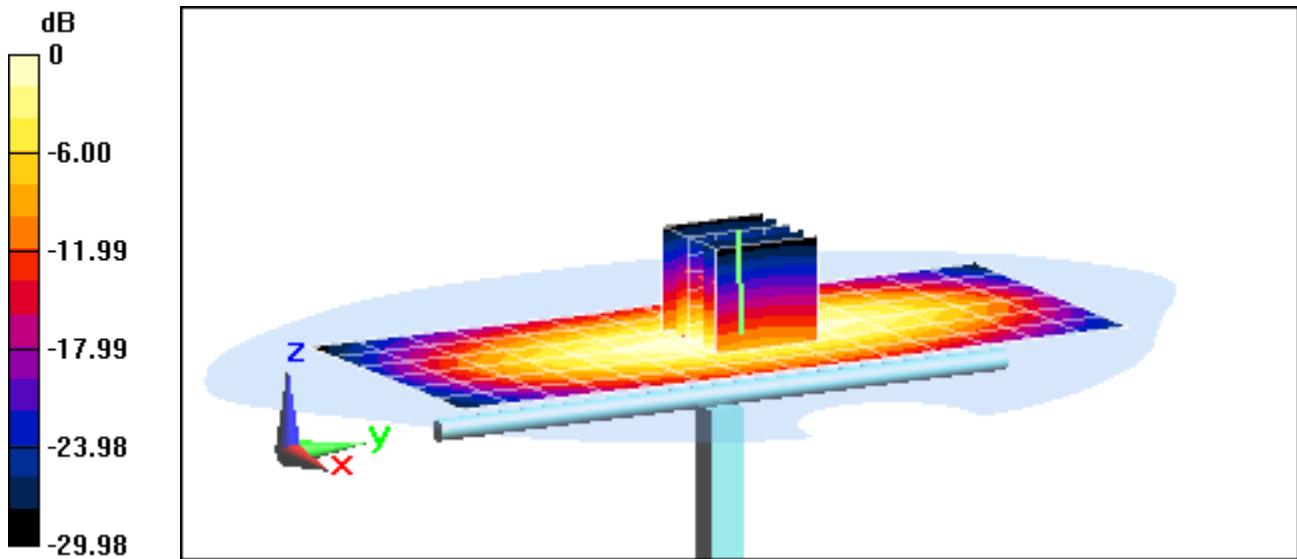

0 dB = 2.00 W/kg = 3.01 dBW/kg

PCTEST ENGINEERING LABORATORY, INC.

DUT: Dipole 835 MHz; Type: D835V2; Serial: 4d133

Communication System: UID 0, CW; Frequency: 835 MHz; Duty Cycle: 1:1

Medium: 835 Body Medium parameters used:

$f = 835 \text{ MHz}$; $\sigma = 0.973 \text{ S/m}$; $\epsilon_r = 52.954$; $\rho = 1000 \text{ kg/m}^3$

Phantom section: Flat Section ; Space: 1.5 cm

Test Date: 04-10-2016; Ambient Temp: 20.1°C; Tissue Temp: 20.5°C

Probe: ES3DV3 - SN3318; ConvF(6.11, 6.11, 6.11); Calibrated: 2/19/2016;

Sensor-Surface: 3mm (Mechanical Surface Detection)

Electronics: DAE4 Sn665; Calibrated: 2/19/2016

Phantom: SAM with CRP v4.0; Type: QD000P40CD; Serial: TP:1800

Measurement SW: DASY52, Version 52.8 (8);SEMCAD X Version 14.6.10 (7331)

835 MHz System Verification at 23.0 dBm (200 mW)

Area Scan (7x14x1): Measurement grid: dx=15mm, dy=15mm

Zoom Scan (5x5x7)/Cube 0: Measurement grid: dx=8mm, dy=8mm, dz=5mm

Peak SAR (extrapolated) = 2.89 W/kg

SAR(1 g) = 2.00 W/kg

Deviation(1 g) = 8.11%

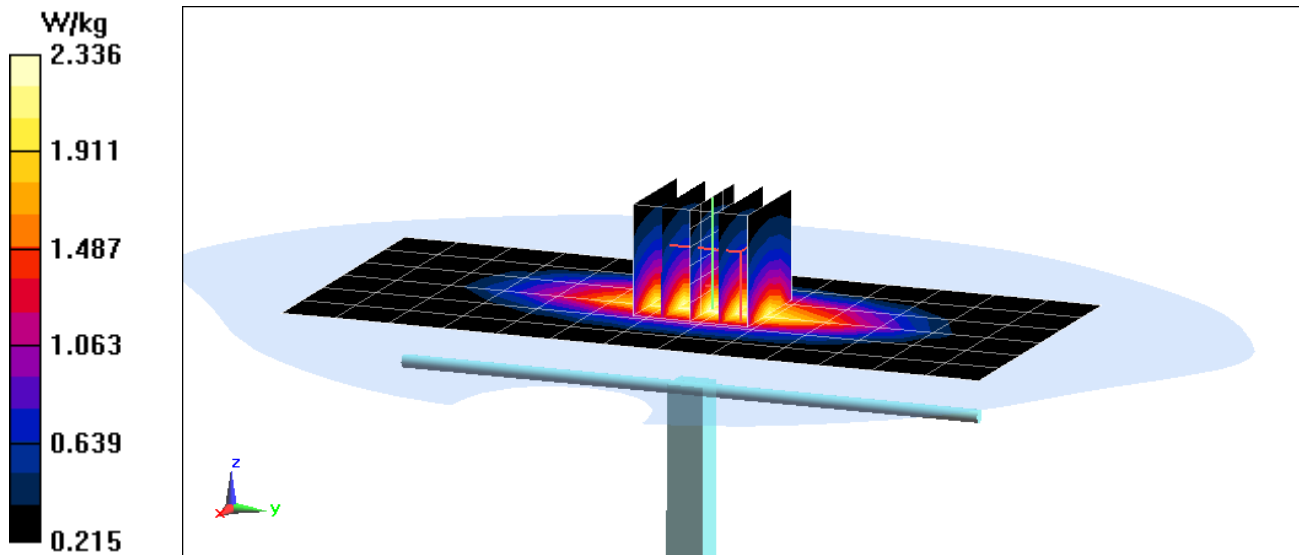

PCTEST ENGINEERING LABORATORY, INC.

DUT: Dipole 1750 MHz; Type: D1750V2; Serial: 1051

Communication System: UID 0, CW; Frequency: 1750 MHz; Duty Cycle: 1:1

Medium: 1750 Body Medium parameters used:

$f = 1750 \text{ MHz}$; $\sigma = 1.485 \text{ S/m}$; $\epsilon_r = 55.414$; $\rho = 1000 \text{ kg/m}^3$

Phantom section: Flat Section ; Space: 1.0 cm

Test Date: 04-06-2016; Ambient Temp: 23.0°C; Tissue Temp: 22.6°C

Probe: ES3DV3 - SN3351; ConvF(4.88, 4.88, 4.88); Calibrated: 6/22/2015;

Sensor-Surface: 3mm (Mechanical Surface Detection)

Electronics: DAE4 Sn1322; Calibrated: 8/24/2015

Phantom: SAM V5.0 Right; Type: QD000P40CD; Serial: 1647

Measurement SW: DASY52, Version 52.8 (8);SEMCAD X Version 14.6.10 (7331)

1750 MHz System Verification at 20.0 dBm (100 mW)

Area Scan (7x9x1): Measurement grid: dx=15mm, dy=15mm

Zoom Scan (5x6x7)/Cube 0: Measurement grid: dx=8mm, dy=8mm, dz=5mm

Peak SAR (extrapolated) = 6.30 W/kg

SAR(1 g) = 3.65 W/kg

Deviation(1 g) = -1.62%

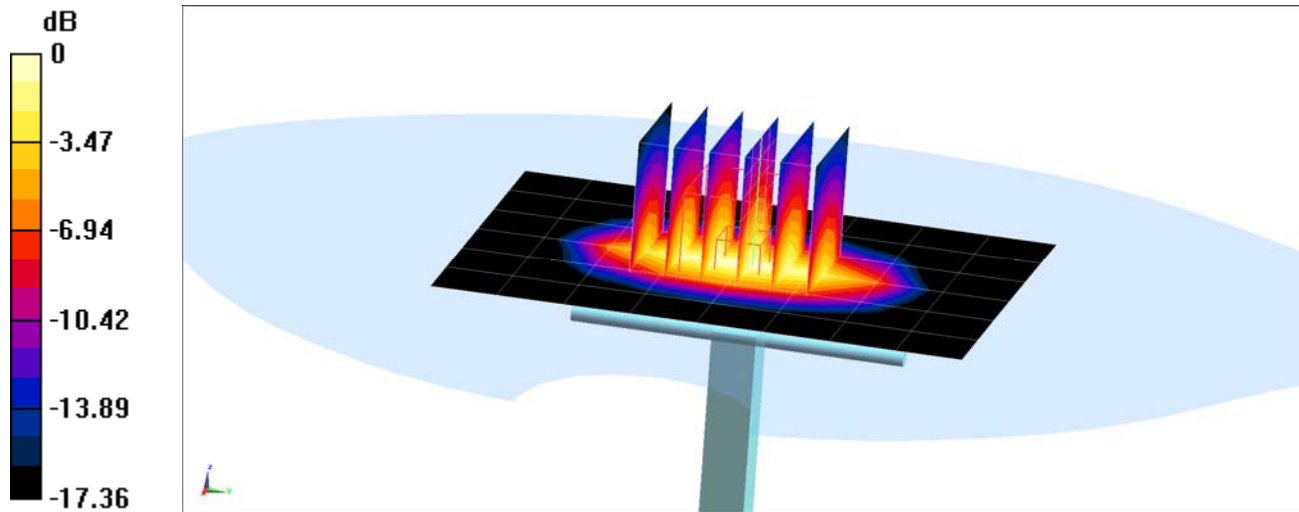

0 dB = 4.55 W/kg = 6.58 dBW/kg

PCTEST ENGINEERING LABORATORY, INC.

DUT: Dipole 1750 MHz; Type: D1765V2; Serial: 1008

Communication System: UID 0, CW; Frequency: 1750 MHz; Duty Cycle: 1:1

Medium: 1750 Body Medium parameters used:

$f = 1750 \text{ MHz}$; $\sigma = 1.477 \text{ S/m}$; $\epsilon_r = 51.191$; $\rho = 1000 \text{ kg/m}^3$

Phantom section: Flat Section; Space: 1.0 cm

Test Date: 04-11-2016; Ambient Temp: 23.0°C; Tissue Temp: 22.3°C

Probe: ES3DV3 - SN3351; ConvF(4.88, 4.88, 4.88); Calibrated: 6/22/2015;

Sensor-Surface: 3mm (Mechanical Surface Detection)

Electronics: DAE4 Sn1322; Calibrated: 8/24/2015

Phantom: SAM V5.0 Right; Type: QD000P40CD; Serial: 1647

Measurement SW: DASY52, Version 52.8 (8); SEMCAD X Version 14.6.10 (7331)

1750 MHz System Verification at 20.0 dBm (100 mW)

Area Scan (7x9x1): Measurement grid: dx=15mm, dy=15mm

Zoom Scan (5x5x7)/Cube 0: Measurement grid: dx=8mm, dy=8mm, dz=5mm

Peak SAR (extrapolated) = 6.49 W/kg

SAR(1 g) = 3.67 W/kg

Deviation(1 g) = -3.42%

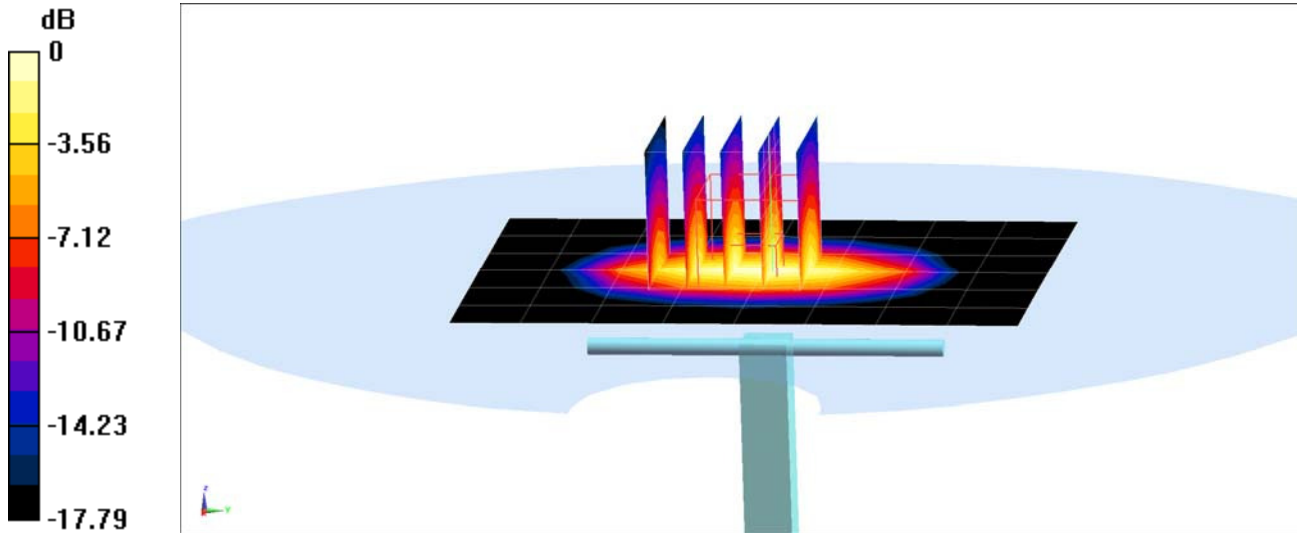

0 dB = 4.57 W/kg = 6.60 dBW/kg

PCTEST ENGINEERING LABORATORY, INC.

DUT: Dipole 1900 MHz; Type: D1900V2; Serial: 5d148

Communication System: UID 0, CW; Frequency: 1900 MHz; Duty Cycle: 1:1
Medium: 1900 Body Medium parameters used (interpolated):
 $f = 1900 \text{ MHz}$; $\sigma = 1.525 \text{ S/m}$; $\epsilon_r = 51.427$; $\rho = 1000 \text{ kg/m}^3$
Phantom section: Flat Section; Space: 1.0 cm

Test Date: 04-05-2016; Ambient Temp: 23.1°C; Tissue Temp: 22.2°C

Probe: ES3DV3 - SN3334; ConvF(4.84, 4.84, 4.84); Calibrated: 11/17/2015;
Sensor-Surface: 3mm (Mechanical Surface Detection)
Electronics: DAE4 Sn1415; Calibrated: 11/11/2015
Phantom: SAM Front; Type: SAM; Serial: 1686
Measurement SW: DASY52, Version 52.8 (8);SEMCAD X Version 14.6.10 (7331)

1900 MHz System Verification at 20.0 dBm (100 mW)

Area Scan (7x10x1): Measurement grid: dx=15mm, dy=15mm
Zoom Scan (5x5x7)/Cube 0: Measurement grid: dx=8mm, dy=8mm, dz=5mm
Peak SAR (extrapolated) = 7.31 W/kg
SAR(1 g) = 4.09 W/kg
Deviation(1 g) = 3.02%

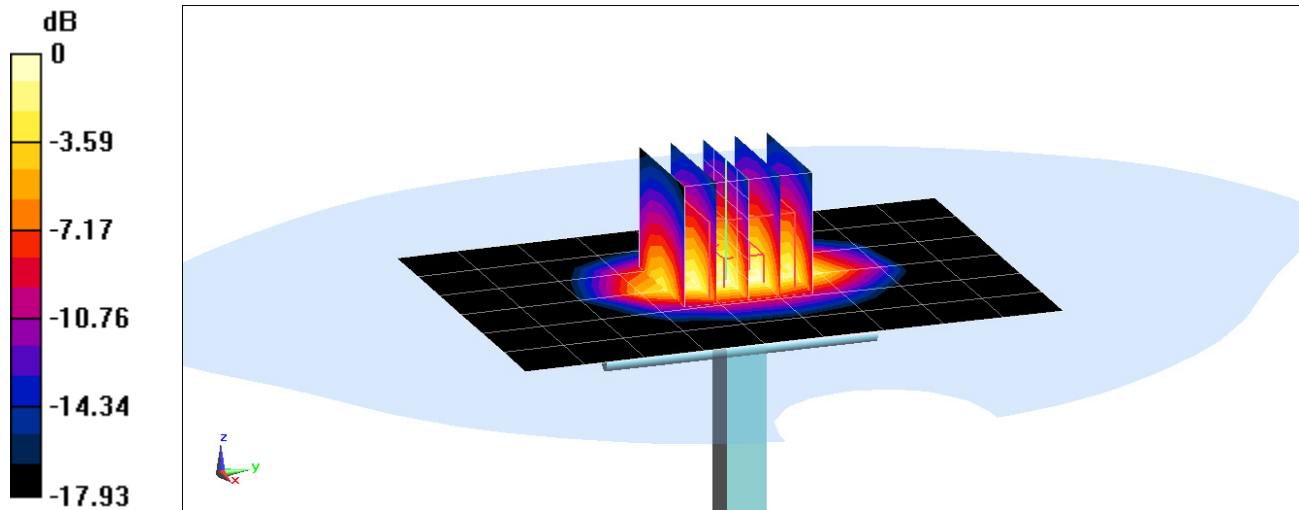

0 dB = 5.14 W/kg = 7.11 dBW/kg

PCTEST ENGINEERING LABORATORY, INC.

DUT: Dipole 2450 MHz; Type: D2450V2; Serial: 882

Communication System: UID 0, CW; Frequency: 2450 MHz; Duty Cycle: 1:1

Medium: 2450 Body Medium parameters used:

$f = 2450 \text{ MHz}$; $\sigma = 2.02 \text{ S/m}$; $\epsilon_r = 51.824$; $\rho = 1000 \text{ kg/m}^3$

Phantom section: Flat Section; Space: 1.0 cm

Test Date: 04-09-2016; Ambient Temp: 22.6°C; Tissue Temp: 22.3°C

Probe: ES3DV3 - SN3334; ConvF(4.45, 4.45, 4.45); Calibrated: 11/17/2015;

Sensor-Surface: 3mm (Mechanical Surface Detection)

Electronics: DAE4 Sn1415; Calibrated: 11/11/2015

Phantom: SAM Front; Type: SAM; Serial: 1686

Measurement SW: DASY52, Version 52.8 (8);SEMCAD X Version 14.6.10 (7331)

2450 MHz System Verification at 20.0 dBm (100 mW)

Area Scan (8x9x1): Measurement grid: dx=12mm, dy=12mm

Zoom Scan (7x7x7)/Cube 0: Measurement grid: dx=5mm, dy=5mm, dz=5mm

Peak SAR (extrapolated) = 11.1 W/kg

SAR(1 g) = 5.22 W/kg

Deviation(1 g) = 5.67%

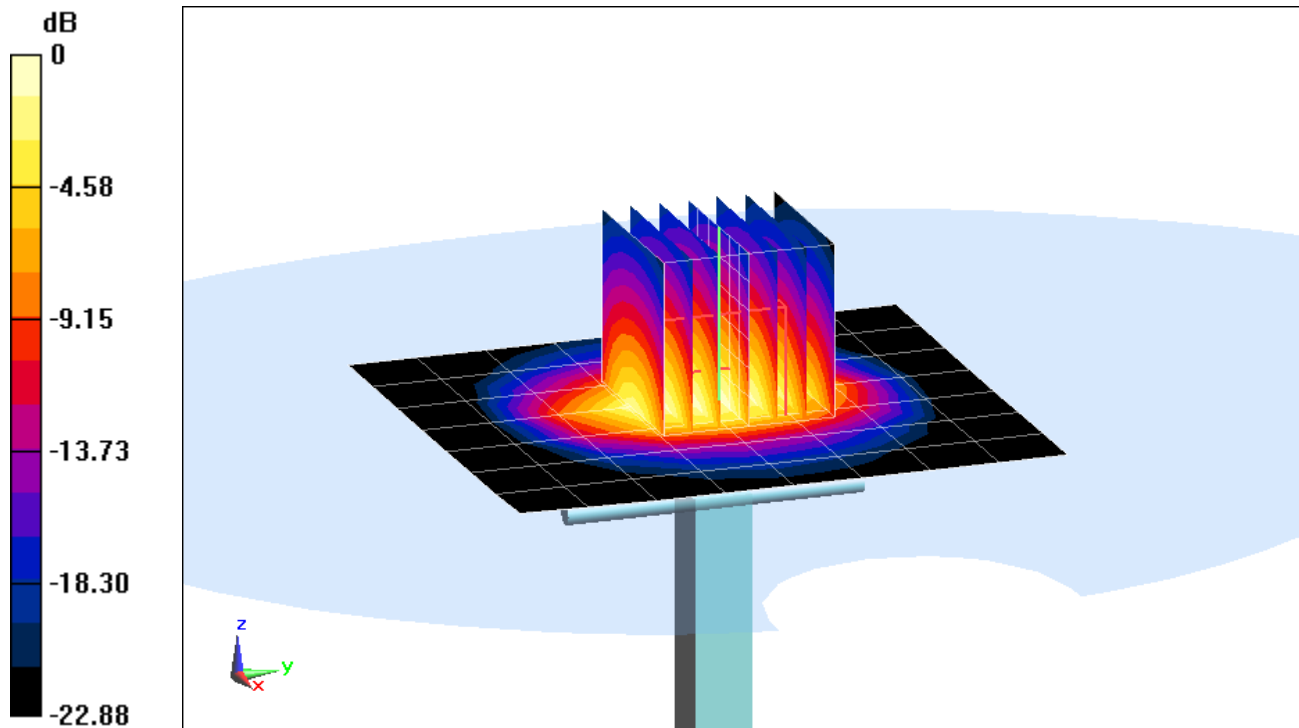

0 dB = 6.87 W/kg = 8.37 dBW/kg

PCTEST ENGINEERING LABORATORY, INC.

DUT: Dipole 2600 MHz; Type: D2600V2; Serial: 1071

Communication System: UID 0, CW; Frequency: 2600 MHz; Duty Cycle: 1:1

Medium: 2450 Body Medium parameters used:

$f = 2600$ MHz; $\sigma = 2.164$ S/m; $\epsilon_r = 50.348$; $\rho = 1000$ kg/m³

Phantom section: Flat Section; Space: 1.0 cm

Test Date: 04-11-2016; Ambient Temp: 24.0°C; Tissue Temp: 23.4°C

Probe: ES3DV2 - SN3022; ConvF(3.96, 3.96, 3.96); Calibrated: 8/26/2015;

Sensor-Surface: 3mm (Mechanical Surface Detection)

Electronics: DAE4 Sn1323; Calibrated: 9/16/2015

Phantom: SAM Left; Type: QD000P40CC; Serial: TP: 1375

Measurement SW: DASY52, Version 52.8 (8); SEMCAD X Version 14.6.10 (7331)

2600 MHz System Verification at 20.0 dBm (100 mW)

Area Scan (8x9x1): Measurement grid: dx=12mm, dy=12mm

Zoom Scan (7x7x7)/Cube 0: Measurement grid: dx=5mm, dy=5mm, dz=5mm

Peak SAR (extrapolated) = 12.8 W/kg

SAR(1 g) = 5.72 W/kg

Deviation(1 g) = 4.19%

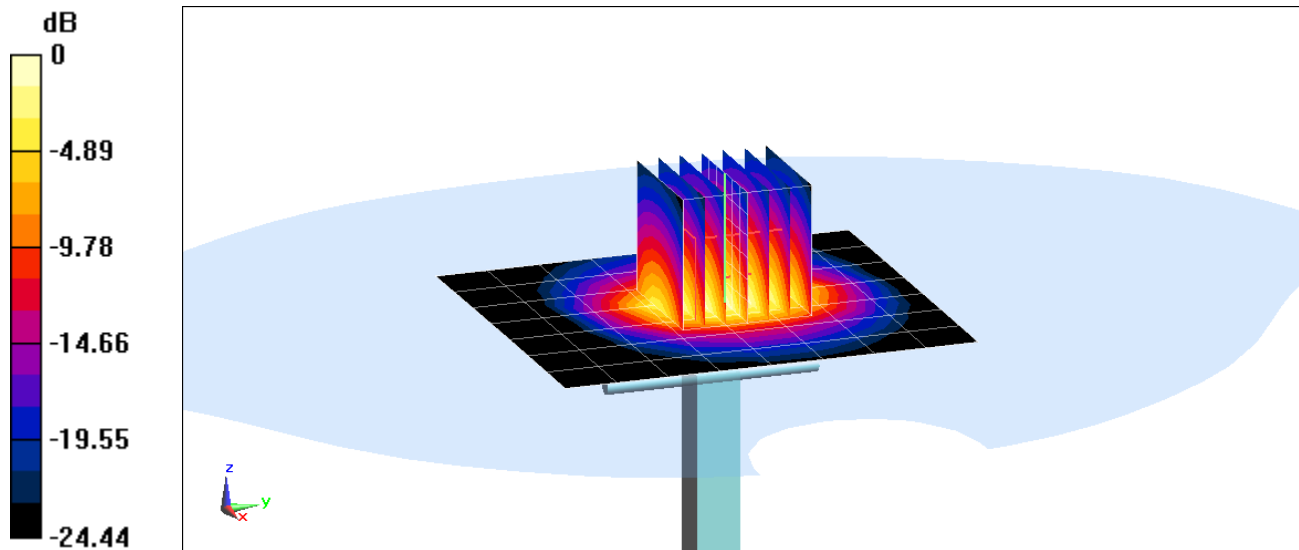

0 dB = 7.55 W/kg = 8.78 dBW/kg

APPENDIX C: PROBE CALIBRATION



Accredited by the Swiss Accreditation Service (SAS)
The Swiss Accreditation Service is one of the signatories to the EA
Multilateral Agreement for the recognition of calibration certificates

Accreditation No.: **SCS 0108**

Client **PC Test**

Certificate No: **D750V3-1003_Jan16**

CALIBRATION CERTIFICATE

Object **D750V3 - SN:1003**

Calibration procedure(s) **QA CAL-05.v9
Calibration procedure for dipole validation kits above 700 MHz**

Calibration date: **January 15, 2016**

*BN ✓
1/28/2016*

This calibration certificate documents the traceability to national standards, which realize the physical units of measurements (SI).
The measurements and the uncertainties with confidence probability are given on the following pages and are part of the certificate.

All calibrations have been conducted in the closed laboratory facility: environment temperature (22 ± 3)°C and humidity < 70%.

Calibration Equipment used (M&TE critical for calibration)

Primary Standards	ID #	Cal Date (Certificate No.)	Scheduled Calibration
Power meter EPM-442A	GB97480704	07-Oct-15 (No. 217-02222)	Oct-16
Power sensor HP 8481A	US37292783	07-Oct-15 (No. 217-02222)	Oct-16
Power sensor HP 8481A	MY41092317	07-Oct-15 (No. 217-02223)	Oct-16
Reference 20 dB Attenuator	SN: 5058 (20k)	01-Apr-15 (No. 217-02131)	Mar-16
Type-N mismatch combination	SN: 5047.2 / 06327	01-Apr-15 (No. 217-02134)	Mar-16
Reference Probe EX3DV4	SN: 7349	31-Dec-15 (No. EX3-7349_Dec15)	Dec-16
DAE4	SN: 601	30-Dec-15 (No. DAE4-601_Dec15)	Dec-16
Secondary Standards	ID #	Check Date (in house)	Scheduled Check
RF generator R&S SMT-06	100972	15-Jun-15 (in house check Jun-15)	In house check: Jun-18
Network Analyzer HP 8753E	US37390585 S4206	18-Oct-01 (in house check Oct-15)	In house check: Oct-16

Calibrated by: **Jeton Kastrati** Function: **Laboratory Technician** Signature: *[Signature]*

Approved by: **Katja Pokovic** Technical Manager Signature: *[Signature]*

Issued: January 15, 2016

This calibration certificate shall not be reproduced except in full without written approval of the laboratory.



Accredited by the Swiss Accreditation Service (SAS)

Accreditation No.: **SCS 0108**

The Swiss Accreditation Service is one of the signatories to the EA Multilateral Agreement for the recognition of calibration certificates

Glossary:

TSL	tissue simulating liquid
ConvF	sensitivity in TSL / NORM x,y,z
N/A	not applicable or not measured

Calibration is Performed According to the Following Standards:

- IEEE Std 1528-2013, "IEEE Recommended Practice for Determining the Peak Spatial-Averaged Specific Absorption Rate (SAR) in the Human Head from Wireless Communications Devices: Measurement Techniques", June 2013
- IEC 62209-1, "Procedure to measure the Specific Absorption Rate (SAR) for hand-held devices used in close proximity to the ear (frequency range of 300 MHz to 3 GHz)", February 2005
- IEC 62209-2, "Procedure to determine the Specific Absorption Rate (SAR) for wireless communication devices used in close proximity to the human body (frequency range of 30 MHz to 6 GHz)", March 2010
- KDB 865664, "SAR Measurement Requirements for 100 MHz to 6 GHz"

Additional Documentation:

- DASY4/5 System Handbook

Methods Applied and Interpretation of Parameters:

- Measurement Conditions:** Further details are available from the Validation Report at the end of the certificate. All figures stated in the certificate are valid at the frequency indicated.
- Antenna Parameters with TSL:** The dipole is mounted with the spacer to position its feed point exactly below the center marking of the flat phantom section, with the arms oriented parallel to the body axis.
- Feed Point Impedance and Return Loss:** These parameters are measured with the dipole positioned under the liquid filled phantom. The impedance stated is transformed from the measurement at the SMA connector to the feed point. The Return Loss ensures low reflected power. No uncertainty required.
- Electrical Delay:** One-way delay between the SMA connector and the antenna feed point. No uncertainty required.
- SAR measured:** SAR measured at the stated antenna input power.
- SAR normalized:** SAR as measured, normalized to an input power of 1 W at the antenna connector.
- SAR for nominal TSL parameters:** The measured TSL parameters are used to calculate the nominal SAR result.

The reported uncertainty of measurement is stated as the standard uncertainty of measurement multiplied by the coverage factor $k=2$, which for a normal distribution corresponds to a coverage probability of approximately 95%.

Measurement Conditions

DASY system configuration, as far as not given on page 1.

DASY Version	DASY5	V52.8.8
Extrapolation	Advanced Extrapolation	
Phantom	Modular Flat Phantom	
Distance Dipole Center - TSL	15 mm	with Spacer
Zoom Scan Resolution	dx, dy, dz = 5 mm	
Frequency	750 MHz \pm 1 MHz	

Head TSL parameters

The following parameters and calculations were applied.

	Temperature	Permittivity	Conductivity
Nominal Head TSL parameters	22.0 °C	41.9	0.89 mho/m
Measured Head TSL parameters	(22.0 \pm 0.2) °C	42.2 \pm 6 %	0.91 mho/m \pm 6 %
Head TSL temperature change during test	< 0.5 °C	---	---

SAR result with Head TSL

SAR averaged over 1 cm ³ (1 g) of Head TSL	Condition	
SAR measured	250 mW input power	2.12 W/kg
SAR for nominal Head TSL parameters	normalized to 1W	8.35 W/kg \pm 17.0 % (k=2)

SAR averaged over 10 cm ³ (10 g) of Head TSL	condition	
SAR measured	250 mW input power	1.39 W/kg
SAR for nominal Head TSL parameters	normalized to 1W	5.49 W/kg \pm 16.5 % (k=2)

Body TSL parameters

The following parameters and calculations were applied.

	Temperature	Permittivity	Conductivity
Nominal Body TSL parameters	22.0 °C	55.5	0.96 mho/m
Measured Body TSL parameters	(22.0 \pm 0.2) °C	55.4 \pm 6 %	0.98 mho/m \pm 6 %
Body TSL temperature change during test	< 0.5 °C	---	---

SAR result with Body TSL

SAR averaged over 1 cm ³ (1 g) of Body TSL	Condition	
SAR measured	250 mW input power	2.20 W/kg
SAR for nominal Body TSL parameters	normalized to 1W	8.66 W/kg \pm 17.0 % (k=2)

SAR averaged over 10 cm ³ (10 g) of Body TSL	condition	
SAR measured	250 mW input power	1.45 W/kg
SAR for nominal Body TSL parameters	normalized to 1W	5.73 W/kg \pm 16.5 % (k=2)

Appendix (Additional assessments outside the scope of SCS 0108)

Antenna Parameters with Head TSL

Impedance, transformed to feed point	53.7 Ω - 2.3 j Ω
Return Loss	- 27.6 dB

Antenna Parameters with Body TSL

Impedance, transformed to feed point	49.3 Ω - 4.3 j Ω
Return Loss	- 27.3 dB

General Antenna Parameters and Design

Electrical Delay (one direction)	1.043 ns
----------------------------------	----------

After long term use with 100W radiated power, only a slight warming of the dipole near the feedpoint can be measured.

The dipole is made of standard semirigid coaxial cable. The center conductor of the feeding line is directly connected to the second arm of the dipole. The antenna is therefore short-circuited for DC-signals. On some of the dipoles, small end caps are added to the dipole arms in order to improve matching when loaded according to the position as explained in the "Measurement Conditions" paragraph. The SAR data are not affected by this change. The overall dipole length is still according to the Standard.

No excessive force must be applied to the dipole arms, because they might bend or the soldered connections near the feedpoint may be damaged.

Additional EUT Data

Manufactured by	SPEAG
Manufactured on	January 21, 2009

DASY5 Validation Report for Head TSL

Date: 15.01.2016

Test Laboratory: SPEAG, Zurich, Switzerland

DUT: Dipole 750 MHz; Type: D750V3; Serial: D750V3 - SN:1003

Communication System: UID 0 - CW; Frequency: 750 MHz

Medium parameters used: $f = 750$ MHz; $\sigma = 0.91$ S/m; $\epsilon_r = 42.2$; $\rho = 1000$ kg/m³

Phantom section: Flat Section

Measurement Standard: DASY5 (IEEE/IEC/ANSI C63.19-2011)

DASY52 Configuration:

- Probe: EX3DV4 - SN7349; ConvF(10.28, 10.28, 10.28); Calibrated: 31.12.2015;
- Sensor-Surface: 1.4mm (Mechanical Surface Detection)
- Electronics: DAE4 Sn601; Calibrated: 30.12.2015
- Phantom: Flat Phantom 4.9L; Type: QD000P49AA; Serial: 1001
- DASY52 52.8.8(1258); SEMCAD X 14.6.10(7372)

Dipole Calibration for Head Tissue EX-Probe/Pin=250 mW, d=15mm/Zoom Scan

(7x7x7)/Cube 0: Measurement grid: dx=5mm, dy=5mm, dz=5mm

Reference Value = 58.50 V/m; Power Drift = 0.01 dB

Peak SAR (extrapolated) = 3.18 W/kg

SAR(1 g) = 2.12 W/kg; SAR(10 g) = 1.39 W/kg

Maximum value of SAR (measured) = 2.83 W/kg

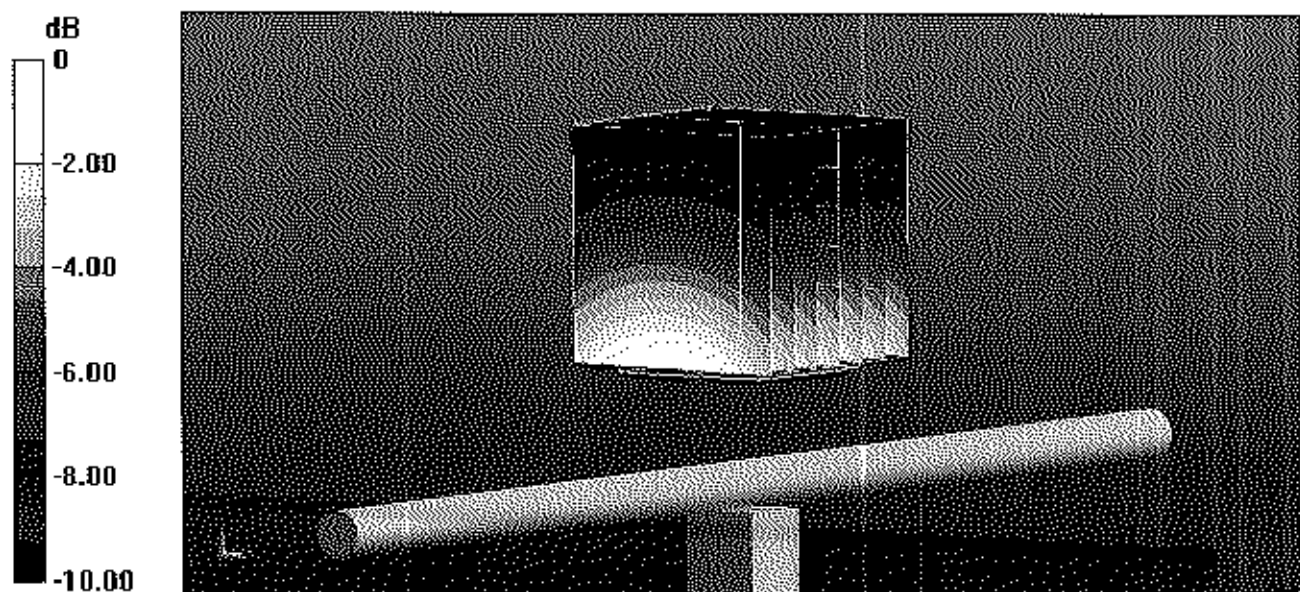

0 dB = 2.83 W/kg = 4.52 dBW/kg

Impedance Measurement Plot for Head TSL

CH1 S11 1 U FS 15 Jan 2016 11:35:50
 1: 53.707 Ω -2.2500 Ω 94.314 μ F 750.000 000 MHz

*
 De1
 C4
 Avg
 16
 H1d

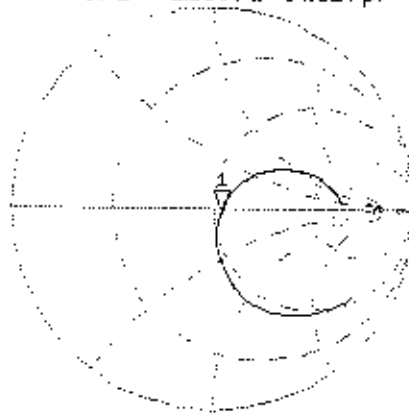

CH2 S11 L06 5 dB/REF -20 dB 1: -27.572 dB 750.000 000 MHz

C4
 Avg
 16
 H1d

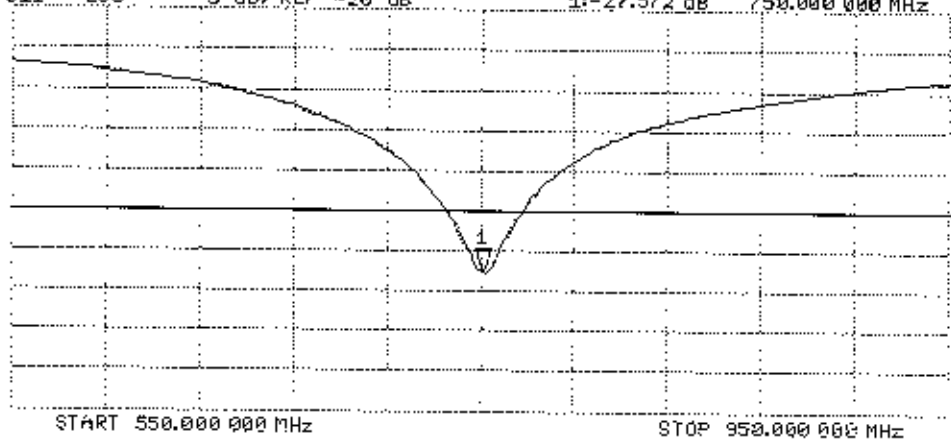

DASY5 Validation Report for Body TSL

Date: 15.01.2016

Test Laboratory: SPEAG, Zurich, Switzerland

DUT: Dipole 750 MHz; Type: D750V3; Serial: D750V3 - SN:1003

Communication System: UID 0 - CW; Frequency: 750 MHz

Medium parameters used: $f = 750$ MHz; $\sigma = 0.98$ S/m; $\epsilon_r = 55.4$; $\rho = 1000$ kg/m³

Phantom section: Flat Section

Measurement Standard: DASY5 (IEEE/IEC/ANSI C63.19-2011)

DASY52 Configuration:

- Probe: EX3DV4 - SN7349; ConvF(9.99, 9.99, 9.99); Calibrated: 31.12.2015;
- Sensor-Surface: 1.4mm (Mechanical Surface Detection)
- Electronics: DAE4 Sn601; Calibrated: 30.12.2015
- Phantom: Flat Phantom 4.9L; Type: QD000P49AA; Serial: 1001
- DASY52 52.8.8(1258); SEMCAD X 14.6.10(7372)

Dipole Calibration for Body Tissue EX-Probe/Pin=250 mW, d=15mm/Zoom Scan

(7x7x7)/Cube 0: Measurement grid: dx=5mm, dy=5mm, dz=5mm

Reference Value = 56.97 V/m; Power Drift = -0.01 dB

Peak SAR (extrapolated) = 3.27 W/kg

SAR(1 g) = 2.2 W/kg; SAR(10 g) = 1.45 W/kg

Maximum value of SAR (measured) = 2.91 W/kg

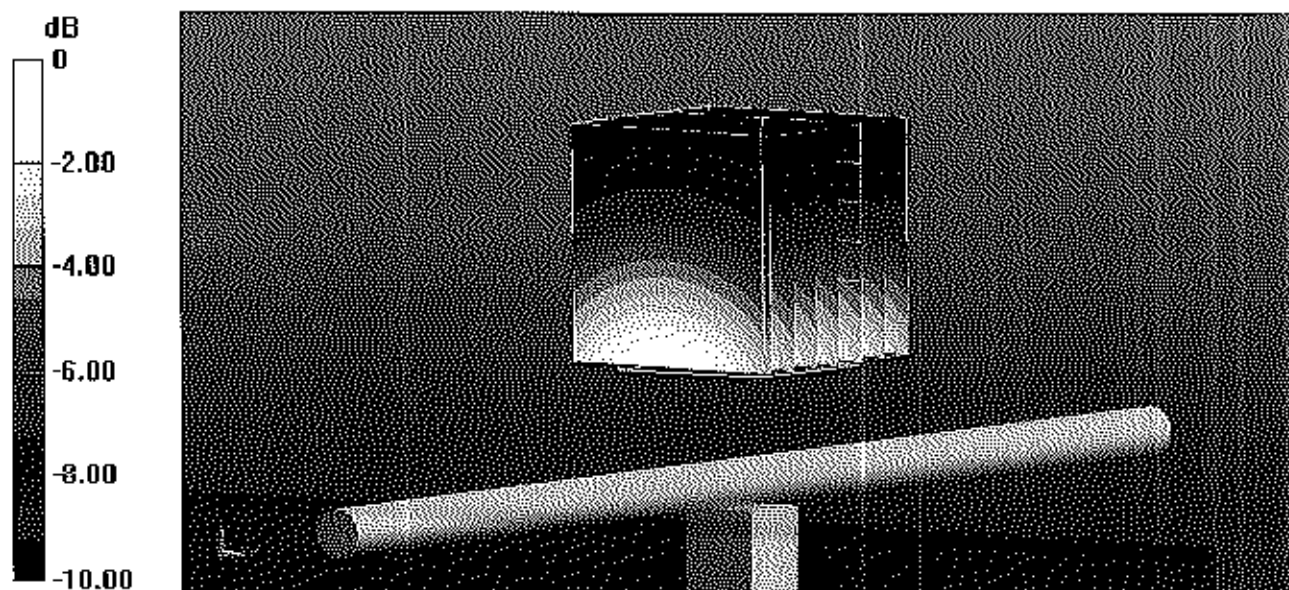

0 dB = 2.91 W/kg = 4.64 dBW/kg

Impedance Measurement Plot for Body TSL

15 Jan 2016 11:11:42
[CH1] S11 1 U FS 1: 49.342 Ω -4.2528 Ω 49.908 pF 750.000 000 MHz

De1
CA
Avg
16
H1d

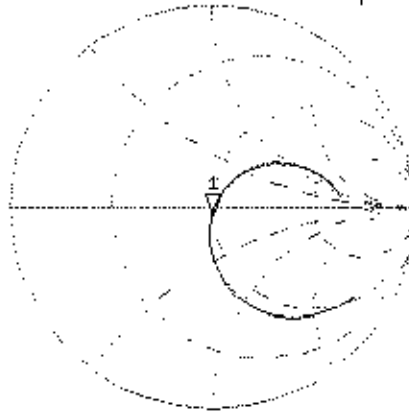

CH2 S11 106 5 dB/REF -20 dB 1: -27.275 dB 750.000 000 MHz

CA
Avg
16
H1d

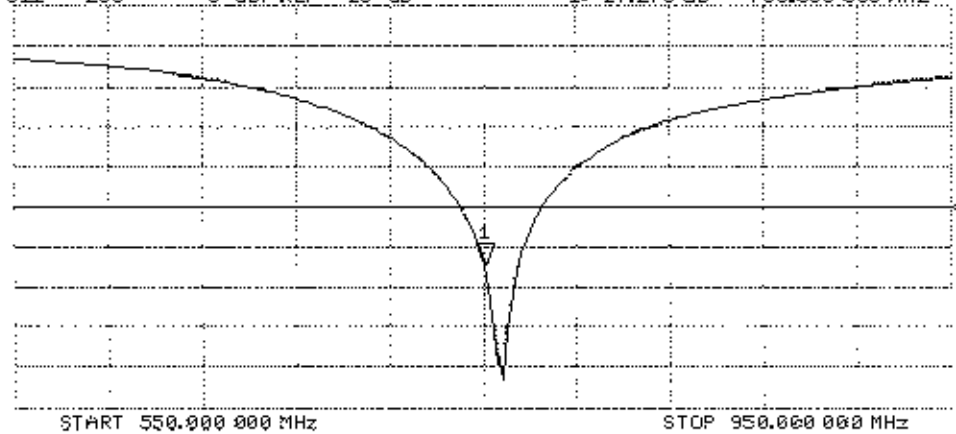



Accredited by the Swiss Accreditation Service (SAS)
The Swiss Accreditation Service is one of the signatories to the EA
Multilateral Agreement for the recognition of calibration certificates

Accreditation No.: **SCS 0108**

Client **PC Test**

Certificate No: **D750V3-1054_Mar16**

CALIBRATION CERTIFICATE

Object **D750V3 - SN:1054**

Calibration procedure(s) **QA CAL-05.v9
Calibration procedure for dipole validation kits above 700 MHz**

Calibration date: **March 16, 2016**

*BN
03/30/2016*

This calibration certificate documents the traceability to national standards, which realize the physical units of measurements (SI).
The measurements and the uncertainties with confidence probability are given on the following pages and are part of the certificate.

All calibrations have been conducted in the closed laboratory facility: environment temperature (22 ± 3)°C and humidity < 70%.

Calibration Equipment used (M&TE critical for calibration)

Primary Standards	ID #	Cal Date (Certificate No.)	Scheduled Calibration
Power meter EPM-442A	GB37480704	07-Oct-15 (No. 217-02222)	Oct-16
Power sensor HP 8481A	US37292783	07-Oct-15 (No. 217-02222)	Oct-16
Power sensor HP 8481A	MY41092317	07-Oct-15 (No. 217-02223)	Oct-16
Reference 20 dB Attenuator	SN: 5058 (20k)	01-Apr-15 (No. 217-02131)	Mar-16
Type-N mismatch combination	SN: 5047.2 / 06327	01-Apr-15 (No. 217-02134)	Mar-16
Reference Probe EX3DV4	SN: 7349	31-Dec-15 (No. EX3-7349_Dec15)	Dec-16
DAE4	SN: 601	30-Dec-15 (No. DAE4-601_Dec15)	Dec-16

Secondary Standards	ID #	Check Date (in house)	Scheduled Check
RF generator R&S SMT-06	100972	15-Jun-15 (in house check Jun-15)	In house check: Jun-18
Network Analyzer HP 8753E	US37390585 S4206	18-Oct-01 (in house check Oct-15)	In house check: Oct-16

Calibrated by: **Jeton Kastrati** (Name) **Laboratory Technician** (Function) *[Signature]* (Signature)

Approved by: **Katja Pokovic** (Name) **Technical Manager** (Function) *[Signature]* (Signature)

Issued: March 16, 2016

This calibration certificate shall not be reproduced except in full without written approval of the laboratory.



Accredited by the Swiss Accreditation Service (SAS)
The Swiss Accreditation Service is one of the signatories to the EA
Multilateral Agreement for the recognition of calibration certificates

Accreditation No.: **SCS 0108**

Glossary:

TSL	tissue simulating liquid
ConvF	sensitivity in TSL / NORM x,y,z
N/A	not applicable or not measured

Calibration is Performed According to the Following Standards:

- IEEE Std 1528-2013, "IEEE Recommended Practice for Determining the Peak Spatial-Averaged Specific Absorption Rate (SAR) in the Human Head from Wireless Communications Devices: Measurement Techniques", June 2013
- IEC 62209-1, "Procedure to measure the Specific Absorption Rate (SAR) for hand-held devices used in close proximity to the ear (frequency range of 300 MHz to 3 GHz)", February 2005
- IEC 62209-2, "Procedure to determine the Specific Absorption Rate (SAR) for wireless communication devices used in close proximity to the human body (frequency range of 30 MHz to 6 GHz)", March 2010
- KDB 865664, "SAR Measurement Requirements for 100 MHz to 6 GHz"

Additional Documentation:

- DASY4/5 System Handbook

Methods Applied and Interpretation of Parameters:

- Measurement Conditions:** Further details are available from the Validation Report at the end of the certificate. All figures stated in the certificate are valid at the frequency indicated.
- Antenna Parameters with TSL:** The dipole is mounted with the spacer to position its feed point exactly below the center marking of the flat phantom section, with the arms oriented parallel to the body axis.
- Feed Point Impedance and Return Loss:** These parameters are measured with the dipole positioned under the liquid filled phantom. The impedance stated is transformed from the measurement at the SMA connector to the feed point. The Return Loss ensures low reflected power. No uncertainty required.
- Electrical Delay:** One-way delay between the SMA connector and the antenna feed point. No uncertainty required.
- SAR measured:** SAR measured at the stated antenna input power.
- SAR normalized:** SAR as measured, normalized to an input power of 1 W at the antenna connector.
- SAR for nominal TSL parameters:** The measured TSL parameters are used to calculate the nominal SAR result.

The reported uncertainty of measurement is stated as the standard uncertainty of measurement multiplied by the coverage factor $k=2$, which for a normal distribution corresponds to a coverage probability of approximately 95%.

Measurement Conditions

DASY system configuration, as far as not given on page 1.

DASY Version	DASY5	V52.8.8
Extrapolation	Advanced Extrapolation	
Phantom	Modular Flat Phantom	
Distance Dipole Center - TSL	15 mm	with Spacer
Zoom Scan Resolution	dx, dy, dz = 5 mm	
Frequency	750 MHz ± 1 MHz	

Head TSL parameters

The following parameters and calculations were applied.

	Temperature	Permittivity	Conductivity
Nominal Head TSL parameters	22.0 °C	41.9	0.89 mho/m
Measured Head TSL parameters	(22.0 ± 0.2) °C	41.9 ± 6 %	0.91 mho/m ± 6 %
Head TSL temperature change during test	< 0.5 °C	----	----

SAR result with Head TSL

SAR averaged over 1 cm³ (1 g) of Head TSL	Condition	
SAR measured	250 mW input power	2.09 W/kg
SAR for nominal Head TSL parameters	normalized to 1W	8.22 W/kg ± 17.0 % (k=2)

SAR averaged over 10 cm³ (10 g) of Head TSL	condition	
SAR measured	250 mW input power	1.37 W/kg
SAR for nominal Head TSL parameters	normalized to 1W	5.41 W/kg ± 16.5 % (k=2)

Body TSL parameters

The following parameters and calculations were applied.

	Temperature	Permittivity	Conductivity
Nominal Body TSL parameters	22.0 °C	55.5	0.96 mho/m
Measured Body TSL parameters	(22.0 ± 0.2) °C	54.7 ± 6 %	0.98 mho/m ± 6 %
Body TSL temperature change during test	< 0.5 °C	----	----

SAR result with Body TSL

SAR averaged over 1 cm³ (1 g) of Body TSL	Condition	
SAR measured	250 mW input power	2.18 W/kg
SAR for nominal Body TSL parameters	normalized to 1W	8.56 W/kg ± 17.0 % (k=2)

SAR averaged over 10 cm³ (10 g) of Body TSL	condition	
SAR measured	250 mW input power	1.44 W/kg
SAR for nominal Body TSL parameters	normalized to 1W	5.68 W/kg ± 16.5 % (k=2)

Appendix (Additional assessments outside the scope of SCS 0108)

Antenna Parameters with Head TSL

Impedance, transformed to feed point	54.2 Ω - 0.9 j Ω
Return Loss	- 27.7 dB

Antenna Parameters with Body TSL

Impedance, transformed to feed point	50.1 Ω - 2.3 j Ω
Return Loss	- 32.9 dB

General Antenna Parameters and Design

Electrical Delay (one direction)	1.035 ns
----------------------------------	----------

After long term use with 100W radiated power, only a slight warming of the dipole near the feedpoint can be measured.

The dipole is made of standard semirigid coaxial cable. The center conductor of the feeding line is directly connected to the second arm of the dipole. The antenna is therefore short-circuited for DC-signals. On some of the dipoles, small end caps are added to the dipole arms in order to improve matching when loaded according to the position as explained in the "Measurement Conditions" paragraph. The SAR data are not affected by this change. The overall dipole length is still according to the Standard.

No excessive force must be applied to the dipole arms, because they might bend or the soldered connections near the feedpoint may be damaged.

Additional EUT Data

Manufactured by	SPEAG
Manufactured on	November 08, 2011

DASY5 Validation Report for Head TSL

Date: 16.03.2016

Test Laboratory: SPEAG, Zurich, Switzerland

DUT: Dipole 750 MHz; Type: D750V3; Serial: D750V3 - SN:1054

Communication System: UID 0 - CW; Frequency: 750 MHz

Medium parameters used: $f = 750 \text{ MHz}$; $\sigma = 0.91 \text{ S/m}$; $\epsilon_r = 41.9$; $\rho = 1000 \text{ kg/m}^3$

Measurement Standard: DASY5 (IEEE/IEC/ANSI C63.19-2011)

DASY52 Configuration:

- Probe: EX3DV4 - SN7349; ConvF(10.28, 10.28, 10.28); Calibrated: 31.12.2015;
- Sensor-Surface: 1.4mm (Mechanical Surface Detection)
- Electronics: DAE4 Sn601; Calibrated: 30.12.2015
- Phantom Type: QD000P49AA
- DASY52 52.8.8(1258); SEMCAD X 14.6.10(7372)

Dipole Calibration for Head Tissue EX-Probe/Pin=250 mW, $d=15\text{mm}$ /Zoom Scan

(7x7x7)/Cube 0: Measurement grid: $dx=5\text{mm}$, $dy=5\text{mm}$, $dz=5\text{mm}$

Reference Value = 58.13 V/m; Power Drift = 0.02 dB

Peak SAR (extrapolated) = 3.14 W/kg

SAR(1 g) = 2.09 W/kg; SAR(10 g) = 1.37 W/kg

Maximum value of SAR (measured) = 2.78 W/kg

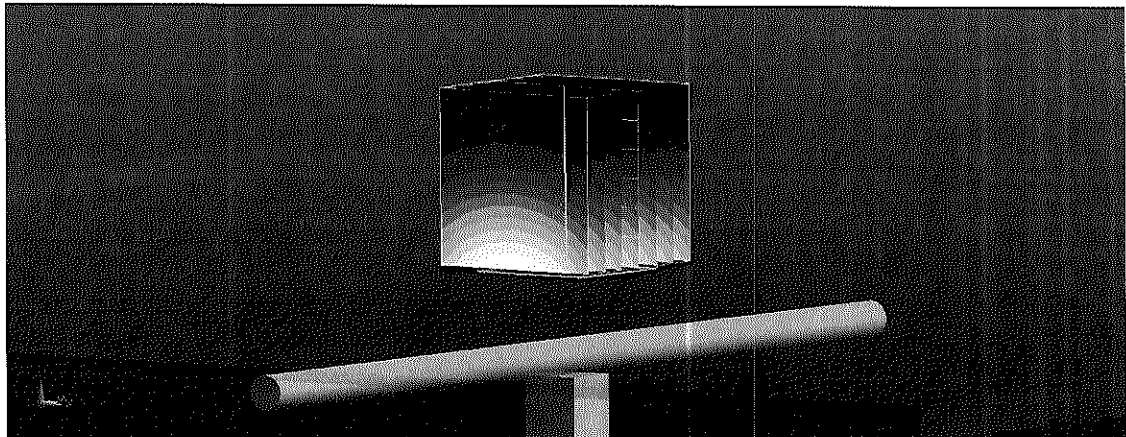
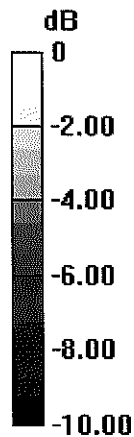

0 dB = 2.78 W/kg = 4.44 dBW/kg

Impedance Measurement Plot for Head TSL

CH1 S11 1 U FS 15 Mar 2016 13:55:57
 1: 54.217 Ω -931.64 m Ω 227.78 pF 750.000 000 MHz

*
 De1
 Ca
 Avg
 16
 H1d

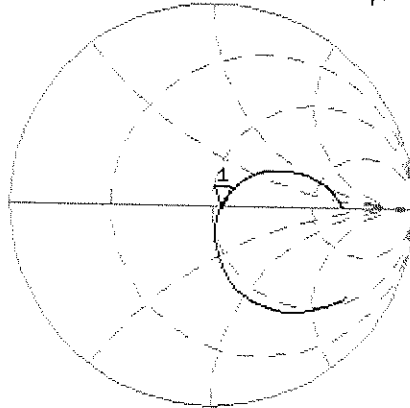

CH2 S11 LOG 5 dB/REF -20 dB 1:-27.652 dB 750.000 000 MHz

Ca
 Avg
 16
 H1d

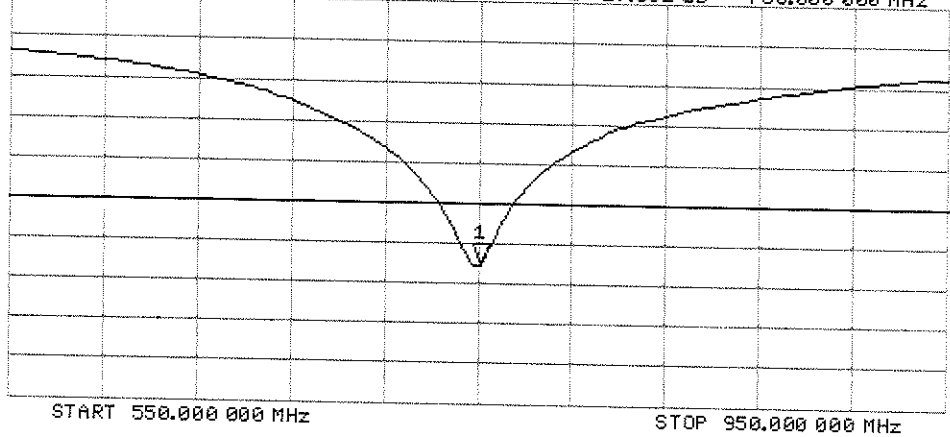

DASY5 Validation Report for Body TSL

Date: 16.03.2016

Test Laboratory: SPEAG, Zurich, Switzerland

DUT: Dipole 750 MHz; Type: D750V3; Serial: D750V3 - SN:1054

Communication System: UID 0 - CW; Frequency: 750 MHz

Medium parameters used: $f = 750$ MHz; $\sigma = 0.98$ S/m; $\epsilon_r = 54.7$; $\rho = 1000$ kg/m³

Measurement Standard: DASY5 (IEEE/IEC/ANSI C63.19-2011)

DASY52 Configuration:

- Probe: EX3DV4 - SN7349; ConvF(9.99, 9.99, 9.99); Calibrated: 31.12.2015;
- Sensor-Surface: 1.4mm (Mechanical Surface Detection)
- Electronics: DAE4 Sn601; Calibrated: 30.12.2015
- Phantom Type: QD000P49AA
- DASY52 52.8.8(1258); SEMCAD X 14.6.10(7372)

Dipole Calibration for Body Tissue EX-Probe/Pin=250 mW, d=15mm/Zoom Scan

(7x7x7)/Cube 0: Measurement grid: dx=5mm, dy=5mm, dz=5mm

Reference Value = 56.90 V/m; Power Drift = 0.00 dB

Peak SAR (extrapolated) = 3.24 W/kg

SAR(1 g) = 2.18 W/kg; SAR(10 g) = 1.44 W/kg

Maximum value of SAR (measured) = 2.89 W/kg

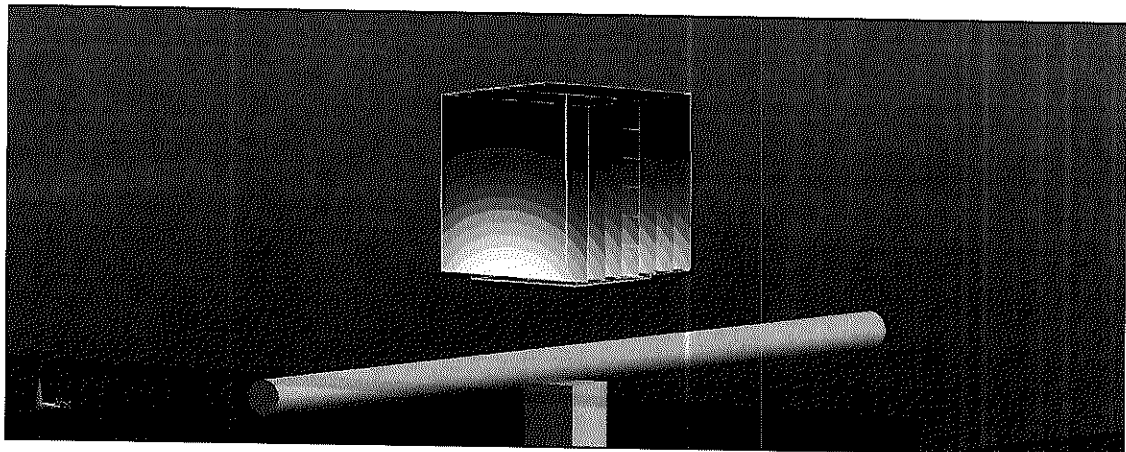
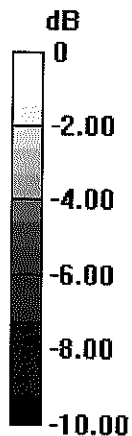

0 dB = 2.89 W/kg = 4.61 dBW/kg

Impedance Measurement Plot for Body TSL

CH1 S11 1 U FS 15 Mar 2016 11:38:16
1: 50.104 Ω -2.2773 Ω 93.102 pF 750.000 000 MHz

*
De1

CA

Avg
16

H1d

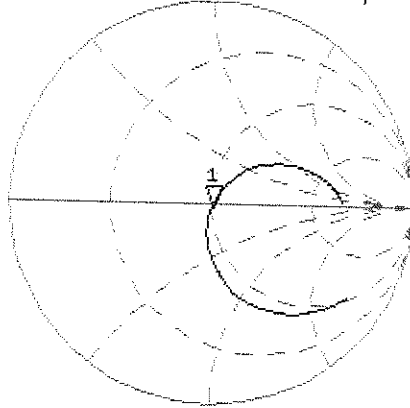

CH2 S11 LOG 5 dB/REF -20 dB 1:-32.854 dB 750.000 000 MHz

CA

Avg
16

H1d

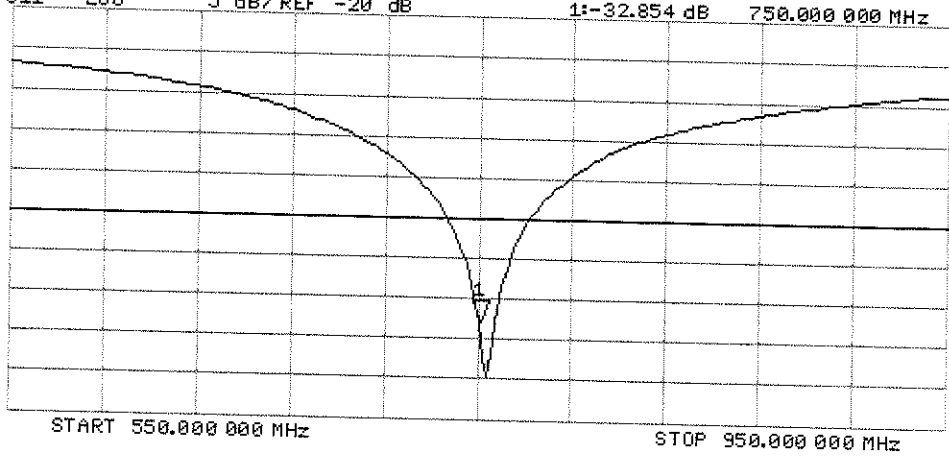



Accredited by the Swiss Accreditation Service (SAS)
The Swiss Accreditation Service is one of the signatories to the EA
Multilateral Agreement for the recognition of calibration certificates

Accreditation No.: **SCS 0108**

Client **PC Test**

Certificate No: **D835V2-4d132_Jan16**

CALIBRATION CERTIFICATE

Object **D835V2 - SN: 4d132**

Calibration procedure(s) **QA-CAL-05.v9
Calibration procedure for dipole validation kits above 700 MHz**

*BNV
1/28/2016*

Calibration date: **January 20, 2016**

This calibration certificate documents the traceability to national standards, which realize the physical units of measurements (SI).
The measurements and the uncertainties with confidence probability are given on the following pages and are part of the certificate.

All calibrations have been conducted in the closed laboratory facility: environment temperature (22 ± 3)°C and humidity < 70%.

Calibration Equipment used (M&TE critical for calibration)

Primary Standards	ID #	Cal Date (Certificate No.)	Scheduled Calibration
Power meter EPM-442A	GB37480704	07-Oct-15 (No. 217-02222)	Oct-16
Power sensor HP 8481A	US37292783	07-Oct-15 (No. 217-02222)	Oct-16
Power sensor HP 8481A	MY41092317	07-Oct-15 (No. 217-02223)	Oct-16
Reference 20 dB Attenuator	SN: 5058 (20k)	01-Apr-15 (No. 217-02131)	Mar-16
Type-N mismatch combination	SN: 5047.2 / 06327	01-Apr-15 (No. 217-02134)	Mar-16
Reference Probe EX3DV4	SN: 7349	31-Dec-15 (No. EX3-7349_Dec15)	Dec-16
DAE4	SN: 601	30-Dec-15 (No. DAE4-601_Dec15)	Dec-16
Secondary Standards	ID #	Check Date (in house)	Scheduled Check
RF generator R&S SMT-06	100972	15-Jun-15 (in house check Jun-15)	In house check: Jun-18
Network Analyzer HP 8759E	US37390585 S4206	19-Oct-01 (in house check Oct-15)	In house check: Oct-16

Calibrated by: **Jeton Kastrati** (Name), **Laboratory Technician** (Function), *[Signature]* (Signature)

Approved by: **Katja Poković** (Name), **Technical Manager** (Function), *[Signature]* (Signature)

Issued: January 20, 2016

This calibration certificate shall not be reproduced except in full without written approval of the laboratory.



Accredited by the Swiss Accreditation Service (SAS)

The Swiss Accreditation Service is one of the signatories to the EA
Multilateral Agreement for the recognition of calibration certificates

Accreditation No.: **SCS 0108**

Glossary:

TSL	tissue simulating liquid
ConvF	sensitivity in TSL / NORM x,y,z
N/A	not applicable or not measured

Calibration is Performed According to the Following Standards:

- IEEE Std 1528-2013, "IEEE Recommended Practice for Determining the Peak Spatial-Averaged Specific Absorption Rate (SAR) in the Human Head from Wireless Communications Devices: Measurement Techniques", June 2013
- IEC 62209-1, "Procedure to measure the Specific Absorption Rate (SAR) for hand-held devices used in close proximity to the ear (frequency range of 300 MHz to 3 GHz)", February 2005
- IEC 62209-2, "Procedure to determine the Specific Absorption Rate (SAR) for wireless communication devices used in close proximity to the human body (frequency range of 30 MHz to 6 GHz)", March 2010
- KDB 865664, "SAR Measurement Requirements for 100 MHz to 6 GHz"

Additional Documentation:

- DASY4/5 System Handbook

Methods Applied and Interpretation of Parameters:

- Measurement Conditions:** Further details are available from the Validation Report at the end of the certificate. All figures stated in the certificate are valid at the frequency indicated.
- Antenna Parameters with TSL:** The dipole is mounted with the spacer to position its feed point exactly below the center marking of the flat phantom section, with the arms oriented parallel to the body axis.
- Feed Point Impedance and Return Loss:** These parameters are measured with the dipole positioned under the liquid filled phantom. The impedance stated is transformed from the measurement at the SMA connector to the feed point. The Return Loss ensures low reflected power. No uncertainty required.
- Electrical Delay:** One-way delay between the SMA connector and the antenna feed point. No uncertainty required.
- SAR measured:** SAR measured at the stated antenna input power.
- SAR normalized:** SAR as measured, normalized to an input power of 1 W at the antenna connector.
- SAR for nominal TSL parameters:** The measured TSL parameters are used to calculate the nominal SAR result.

The reported uncertainty of measurement is stated as the standard uncertainty of measurement multiplied by the coverage factor $k=2$, which for a normal distribution corresponds to a coverage probability of approximately 95%.

Measurement Conditions

DASY system configuration, as far as not given on page 1.

DASY Version	DASYS	V52.8.8
Extrapolation	Advanced Extrapolation	
Phantom	Modular Flat Phantom	
Distance Dipole Center - TSL	15 mm	with Spacer
Zoom Scan Resolution	dx, dy, dz = 5 mm	
Frequency	835 MHz ± 1 MHz	

Head TSL parameters

The following parameters and calculations were applied.

	Temperature	Permittivity	Conductivity
Nominal Head TSL parameters	22.0 °C	41.5	0.90 mho/m
Measured Head TSL parameters	(22.0 ± 0.2) °C	42.0 ± 6 %	0.93 mho/m ± 6 %
Head TSL temperature change during test	< 0.5 °C	---	---

SAR result with Head TSL

SAR averaged over 1 cm³ (1 g) of Head TSL	Condition	
SAR measured	250 mW input power	2.42 W/kg
SAR for nominal Head TSL parameters	normalized to 1W	9.47 W/kg ± 17.0 % (k=2)

SAR averaged over 10 cm³ (10 g) of Head TSL	condition	
SAR measured	250 mW input power	1.57 W/kg
SAR for nominal Head TSL parameters	normalized to 1W	6.17 W/kg ± 16.5 % (k=2)

Body TSL parameters

The following parameters and calculations were applied.

	Temperature	Permittivity	Conductivity
Nominal Body TSL parameters	22.0 °C	55.2	0.97 mho/m
Measured Body TSL parameters	(22.0 ± 0.2) °C	55.2 ± 6 %	1.01 mho/m ± 6 %
Body TSL temperature change during test	< 0.5 °C	---	---

SAR result with Body TSL

SAR averaged over 1 cm³ (1 g) of Body TSL	Condition	
SAR measured	250 mW input power	2.49 W/kg
SAR for nominal Body TSL parameters	normalized to 1W	9.66 W/kg ± 17.0 % (k=2)

SAR averaged over 10 cm³ (10 g) of Body TSL	condition	
SAR measured	250 mW input power	1.63 W/kg
SAR for nominal Body TSL parameters	normalized to 1W	6.37 W/kg ± 16.5 % (k=2)

Appendix (Additional assessments outside the scope of SCS 0108)

Antenna Parameters with Head TSL

Impedance, transformed to feed point	51.2 Ω - 2.7 j Ω
Return Loss	- 30.6 dB

Antenna Parameters with Body TSL

Impedance, transformed to feed point	47.8 Ω - 4.9 j Ω
Return Loss	- 25.3 dB

General Antenna Parameters and Design

Electrical Delay (one direction)	1.388 ns
----------------------------------	----------

After long term use with 100W radiated power, only a slight warming of the dipole near the feedpoint can be measured.

The dipole is made of standard semirigid coaxial cable. The center conductor of the feeding line is directly connected to the second arm of the dipole. The antenna is therefore short-circuited for DC-signals. On some of the dipoles, small end caps are added to the dipole arms in order to improve matching when loaded according to the position as explained in the "Measurement Conditions" paragraph. The SAR data are not affected by this change. The overall dipole length is still according to the Standard.

No excessive force must be applied to the dipole arms, because they might bend or the soldered connections near the feedpoint may be damaged.

Additional EUT Data

Manufactured by	SPEAG
Manufactured on	July 22, 2011

DASY5 Validation Report for Head TSL

Date: 20.01.2016

Test Laboratory: SPEAG, Zurich, Switzerland

DUT: Dipole 835 MHz; Type: D835V2; Serial: D835V2 - SN: 4d132

Communication System: UID 0 - CW; Frequency: 835 MHz

Medium parameters used: $f = 835$ MHz; $\sigma = 0.93$ S/m; $\epsilon_r = 42$; $\rho = 1000$ kg/m³

Phantom section: Flat Section

Measurement Standard: DASY5 (IEEE/IEC/ANSI C63.19-2011)

DASY52 Configuration:

- Probe: EX3DV4 - SN7349; ConvF(9.83, 9.83; 9.83); Calibrated: 31.12.2015;
- Sensor-Surface: 1.4mm (Mechanical Surface Detection)
- Electronics: DAE4 Sn601; Calibrated: 30.12.2015
- Phantom: Flat Phantom 4.9L; Type: QD000P49AA; Serial: 1001
- DASY52 52.8.8(1258); SEMCAD X 14.6.10(7372)

Dipole Calibration for Head Tissue EX-Probe/Pin=250 mW, d=15mm/Zoom Scan

(7x7x7)/Cube 0: Measurement grid: dx=5mm, dy=5mm, dz=5mm

Reference Value = 61.94 V/m; Power Drift = 0.01 dB

Peak SAR (extrapolated) = 3.67 W/kg

SAR(1 g) = 2.42 W/kg; SAR(10 g) = 1.57 W/kg

Maximum value of SAR (measured) = 3.24 W/kg

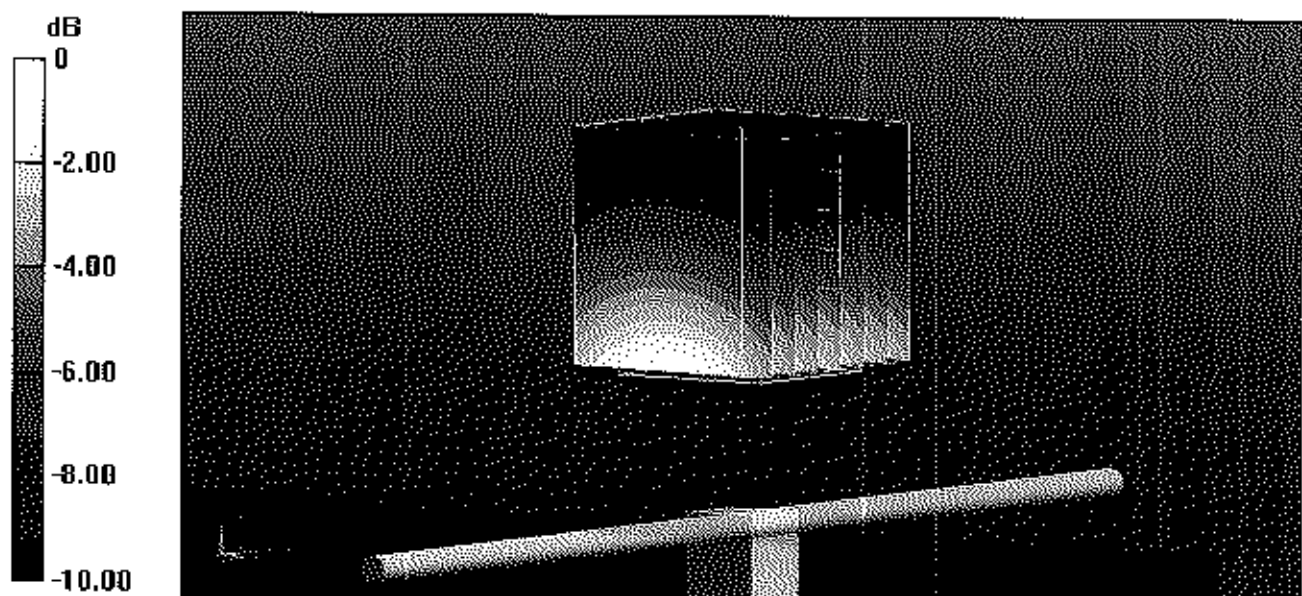

0 dB = 3.24 W/kg = 5.11 dBW/kg

Impedance Measurement Plot for Head TSL

20 Jan 2016 14:27:16
 CH2 S11 1 U FS 2: 51.188 Ω -2.6738 Ω 71.285 pF 835.000 000 MHz

*
 Del
 CA
 Avg
 15
 H1 d

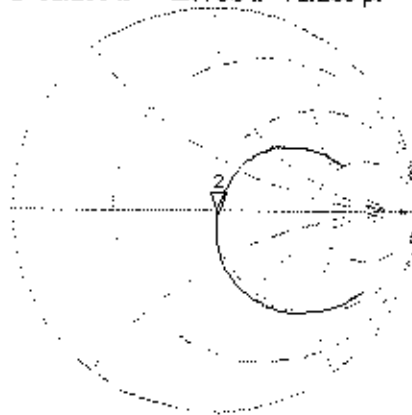

CH2 S11 LOG 5 dB/REF -20 dB 2: -30.776 dB 835.000 000 MHz

CA
 Avg
 16
 H1 d

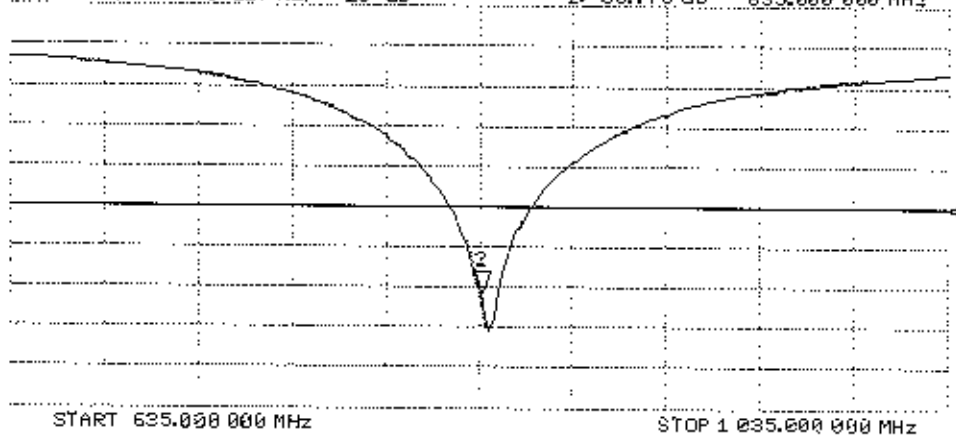

DASY5 Validation Report for Body TSL

Date: 20.01.2016

Test Laboratory: SPEAG, Zurich, Switzerland

DUT: Dipole 835 MHz; Type: D835V2; Serial: D835V2 - SN: 4d132

Communication System: UID 0 - CW; Frequency: 835 MHz

Medium parameters used: $f = 835 \text{ MHz}$; $\sigma = 1.01 \text{ S/m}$; $\epsilon_r = 55.2$; $\rho = 1000 \text{ kg/m}^3$

Phantom section: Flat Section

Measurement Standard: DASY5 (IEEE/IEC/ANSI C63.19-2011)

DASY52 Configuration:

- Probe: EX3DV4 - SN7349; ConvF(9.73, 9.73, 9.73); Calibrated: 31.12.2015;
- Sensor-Surface: 1.4mm (Mechanical Surface Detection)
- Electronics: DAE4 Sn601; Calibrated: 30.12.2015
- Phantom: Flat Phantom 4.9L; Type: QD000P49AA; Serial: 1001
- DASY52 52.8.8(1258); SEMCAD X 14.6.10(7372)

Dipole Calibration for Body Tissue EX-Probe/Pin=250 mW, d=15mm/Zoom Scan

(7x7x7)/Cube 0: Measurement grid: dx=5mm, dy=5mm, dz=5mm

Reference Value = 60.29 V/m; Power Drift = -0.01 dB

Peak SAR (extrapolated) = 3.66 W/kg

SAR(1 g) = 2.49 W/kg; SAR(10 g) = 1.63 W/kg

Maximum value of SAR (measured) = 3.29 W/kg

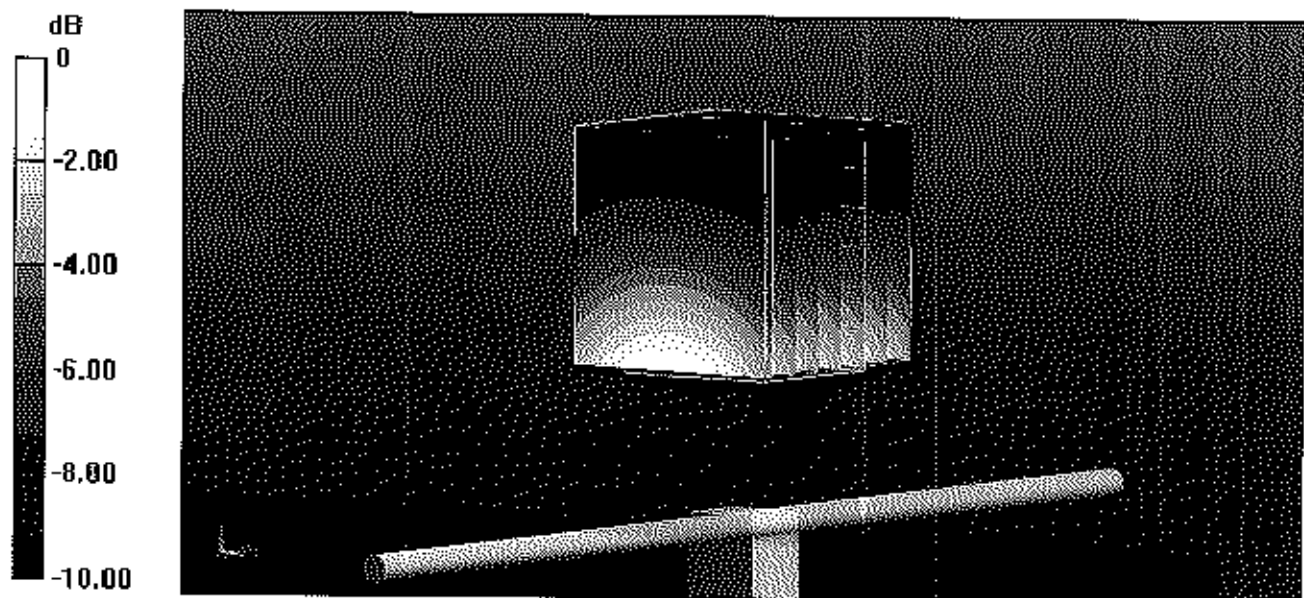

0 dB = 3.29 W/kg = 5.17 dBW/kg

Impedance Measurement Plot for Body TSL

20 Jan 2016 13:29:15
[CH1] S11 1 U FS 2: 47.784 Ω -4.8516 Ω 39.287 pF 835.000 000 MHz

*
Del
CA

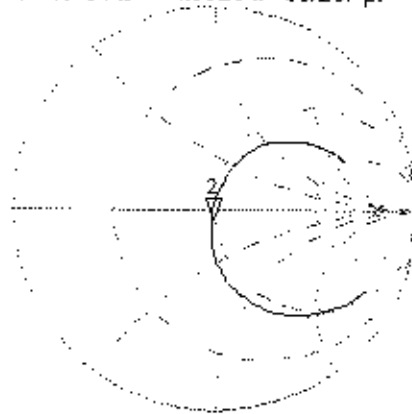

Avg
16

↑

CH2 S11 LOG 5 dB/REF -20 dB 2: -25.260 dB 835.000 000 MHz

CA

Avg
16

↑

START 635.000 000 MHz

STOP 1.535.000 000 MHz



Accredited by the Swiss Accreditation Service (SAS)
The Swiss Accreditation Service is one of the signatories to the EA
Multilateral Agreement for the recognition of calibration certificates

Accreditation No.: **SCS 0108**

Client **PC Test**

Certificate No: **D835V2-4d133_Jul15**

CALIBRATION CERTIFICATE

Object **D835V2 - SN: 4d133**

Calibration procedure(s) **QA CAL-05.v9
Calibration procedure for dipole validation kits above 700 MHz**

PN ✓
8/4/15

Calibration date: **July 23, 2015**

This calibration certificate documents the traceability to national standards, which realize the physical units of measurements (SI).
The measurements and the uncertainties with confidence probability are given on the following pages and are part of the certificate.

All calibrations have been conducted in the closed laboratory facility: environment temperature (22 ± 3)°C and humidity < 70%.

Calibration Equipment used (M&TE critical for calibration)

Primary Standards	ID #	Cal Date (Certificate No.)	Scheduled Calibration
Power meter EPM-442A	GB37480704	07-Oct-14 (No. 217-02020)	Oct-15
Power sensor HP 8481A	US37292783	07-Oct-14 (No. 217-02020)	Oct-15
Power sensor HP 8481A	MY41092317	07-Oct-14 (No. 217-02021)	Oct-15
Reference 20 dB Attenuator	SN: 5058 (20k)	01-Apr-15 (No. 217-02131)	Mar-16
Type-N mismatch combination	SN: 5047.2 / 06327	01-Apr-15 (No. 217-02134)	Mar-16
Reference Probe ES3DV3	SN: 3205	30-Dec-14 (No. ES3-3205_Dec14)	Dec-15
DAE4	SN: 601	18-Aug-14 (No. DAE4-601_Aug14)	Aug-15
Secondary Standards	ID #	Check Date (in house)	Scheduled Check
RF generator R&S SMT-06	100005	04-Aug-99 (in house check Oct-13)	In house check: Oct-16
Network Analyzer HP 8753E	US37390585 S4206	18-Oct-01 (in house check Oct-14)	In house check: Oct-15

Calibrated by: **Michael Weber** Name: Michael Weber Function: Laboratory Technician

Approved by: **Katja Pokovic** Name: Katja Pokovic Function: Technical Manager

Signature

Issued: July 23, 2015

This calibration certificate shall not be reproduced except in full without written approval of the laboratory.



Accredited by the Swiss Accreditation Service (SAS)
The Swiss Accreditation Service is one of the signatories to the EA
Multilateral Agreement for the recognition of calibration certificates

Accreditation No.: **SCS 0108**

Glossary:

TSL	tissue simulating liquid
ConvF	sensitivity in TSL / NORM x,y,z
N/A	not applicable or not measured

Calibration is Performed According to the Following Standards:

- IEEE Std 1528-2013, "IEEE Recommended Practice for Determining the Peak Spatial-Averaged Specific Absorption Rate (SAR) in the Human Head from Wireless Communications Devices: Measurement Techniques", June 2013
- IEC 62209-1, "Procedure to measure the Specific Absorption Rate (SAR) for hand-held devices used in close proximity to the ear (frequency range of 300 MHz to 3 GHz)", February 2005
- IEC 62209-2, "Procedure to determine the Specific Absorption Rate (SAR) for wireless communication devices used in close proximity to the human body (frequency range of 30 MHz to 6 GHz)", March 2010
- KDB 865664, "SAR Measurement Requirements for 100 MHz to 6 GHz"

Additional Documentation:

- DASY4/5 System Handbook

Methods Applied and Interpretation of Parameters:

- Measurement Conditions:* Further details are available from the Validation Report at the end of the certificate. All figures stated in the certificate are valid at the frequency indicated.
- Antenna Parameters with TSL:* The dipole is mounted with the spacer to position its feed point exactly below the center marking of the flat phantom section, with the arms oriented parallel to the body axis.
- Feed Point Impedance and Return Loss:* These parameters are measured with the dipole positioned under the liquid filled phantom. The impedance stated is transformed from the measurement at the SMA connector to the feed point. The Return Loss ensures low reflected power. No uncertainty required.
- Electrical Delay:* One-way delay between the SMA connector and the antenna feed point. No uncertainty required.
- SAR measured:* SAR measured at the stated antenna input power.
- SAR normalized:* SAR as measured, normalized to an input power of 1 W at the antenna connector.
- SAR for nominal TSL parameters:* The measured TSL parameters are used to calculate the nominal SAR result.

The reported uncertainty of measurement is stated as the standard uncertainty of measurement multiplied by the coverage factor $k=2$, which for a normal distribution corresponds to a coverage probability of approximately 95%.

Measurement Conditions

DASY system configuration, as far as not given on page 1.

DASY Version	DASY5	V52.8.8
Extrapolation	Advanced Extrapolation	
Phantom	Modular Flat Phantom	
Distance Dipole Center - TSL	15 mm	with Spacer
Zoom Scan Resolution	dx, dy, dz = 5 mm	
Frequency	835 MHz \pm 1 MHz	

Head TSL parameters

The following parameters and calculations were applied.

	Temperature	Permittivity	Conductivity
Nominal Head TSL parameters	22.0 °C	41.5	0.90 mho/m
Measured Head TSL parameters	(22.0 \pm 0.2) °C	42.4 \pm 6 %	0.92 mho/m \pm 6 %
Head TSL temperature change during test	< 0.5 °C	----	----

SAR result with Head TSL

SAR averaged over 1 cm ³ (1 g) of Head TSL	Condition	
SAR measured	250 mW input power	2.31 W/kg
SAR for nominal Head TSL parameters	normalized to 1W	9.13 W/kg \pm 17.0 % (k=2)

SAR averaged over 10 cm ³ (10 g) of Head TSL	condition	
SAR measured	250 mW input power	1.50 W/kg
SAR for nominal Head TSL parameters	normalized to 1W	5.94 W/kg \pm 16.5 % (k=2)

Body TSL parameters

The following parameters and calculations were applied.

	Temperature	Permittivity	Conductivity
Nominal Body TSL parameters	22.0 °C	55.2	0.97 mho/m
Measured Body TSL parameters	(22.0 \pm 0.2) °C	54.9 \pm 6 %	1.00 mho/m \pm 6 %
Body TSL temperature change during test	< 0.5 °C	----	----

SAR result with Body TSL

SAR averaged over 1 cm ³ (1 g) of Body TSL	Condition	
SAR measured	250 mW input power	2.37 W/kg
SAR for nominal Body TSL parameters	normalized to 1W	9.25 W/kg \pm 17.0 % (k=2)

SAR averaged over 10 cm ³ (10 g) of Body TSL	condition	
SAR measured	250 mW input power	1.55 W/kg
SAR for nominal Body TSL parameters	normalized to 1W	6.08 W/kg \pm 16.5 % (k=2)

Appendix (Additional assessments outside the scope of SCS 0108)

Antenna Parameters with Head TSL

Impedance, transformed to feed point	51.6 Ω - 1.6 j Ω
Return Loss	- 33.1 dB

Antenna Parameters with Body TSL

Impedance, transformed to feed point	48.0 Ω - 3.7 j Ω
Return Loss	- 27.4 dB

General Antenna Parameters and Design

Electrical Delay (one direction)	1.395 ns
----------------------------------	----------

After long term use with 100W radiated power, only a slight warming of the dipole near the feedpoint can be measured.

The dipole is made of standard semirigid coaxial cable. The center conductor of the feeding line is directly connected to the second arm of the dipole. The antenna is therefore short-circuited for DC-signals. On some of the dipoles, small end caps are added to the dipole arms in order to improve matching when loaded according to the position as explained in the "Measurement Conditions" paragraph. The SAR data are not affected by this change. The overall dipole length is still according to the Standard.

No excessive force must be applied to the dipole arms, because they might bend or the soldered connections near the feedpoint may be damaged.

Additional EUT Data

Manufactured by	SPEAG
Manufactured on	July 22, 2011

DASY5 Validation Report for Head TSL

Date: 22.07.2015

Test Laboratory: SPEAG, Zurich, Switzerland

DUT: Dipole 835 MHz; Type: D835V2; Serial: D835V2 - SN: 4d133

Communication System: UID 0 - CW; Frequency: 835 MHz

Medium parameters used: $f = 835$ MHz; $\sigma = 0.92$ S/m; $\epsilon_r = 42.4$; $\rho = 1000$ kg/m³

Phantom section: Flat Section

Measurement Standard: DASY5 (IEEE/IEC/ANSI C63.19-2011)

DASY52 Configuration:

- Probe: ES3DV3 - SN3205; ConvF(6.2, 6.2, 6.2); Calibrated: 30.12.2014;
- Sensor-Surface: 3mm (Mechanical Surface Detection)
- Electronics: DAE4 Sn601; Calibrated: 18.08.2014
- Phantom: Flat Phantom 4.9L; Type: QD000P49AA; Serial: 1001
- DASY52 52.8.8(1222); SEMCAD X 14.6.10(7331)

Dipole Calibration for Head Tissue/Pin=250 mW, d=15mm/Zoom Scan (7x7x7)/Cube 0:

Measurement grid: dx=5mm, dy=5mm, dz=5mm

Reference Value = 56.11 V/m; Power Drift = 0.00 dB

Peak SAR (extrapolated) = 3.44 W/kg

SAR(1 g) = 2.31 W/kg; SAR(10 g) = 1.5 W/kg

Maximum value of SAR (measured) = 2.70 W/kg

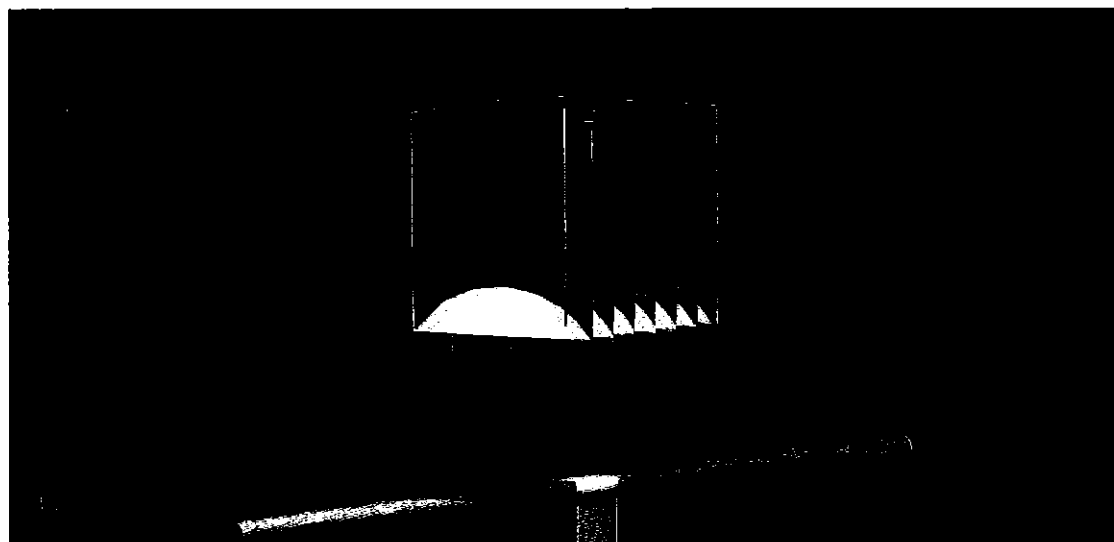
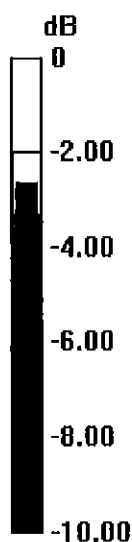

0 dB = 2.70 W/kg = 4.31 dBW/kg

Impedance Measurement Plot for Head TSL

22 Jul 2015 09:20:37

CH1 S11 1 U FS 1: 51.563 Ω -1.6152 Ω 118.00 pF 835.000 000 MHz

*
Del
Cor
Avg
16
H1d

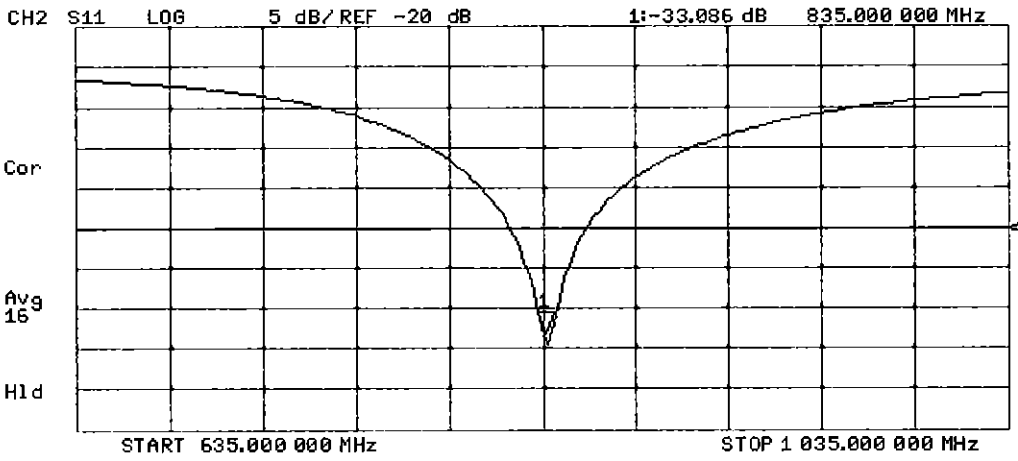
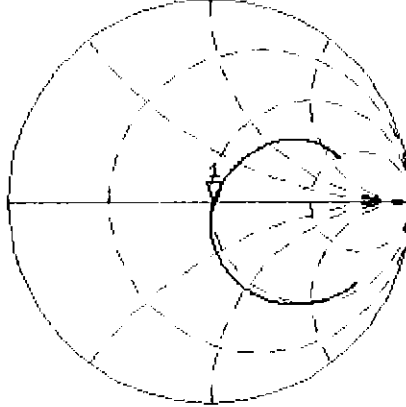

DASY5 Validation Report for Body TSL

Date: 23.07.2015

Test Laboratory: SPEAG, Zurich, Switzerland

DUT: Dipole 835 MHz; Type: D835V2; Serial: D835V2 - SN: 4d133

Communication System: UID 0 - CW; Frequency: 835 MHz

Medium parameters used: $f = 835$ MHz; $\sigma = 1$ S/m; $\epsilon_r = 54.9$; $\rho = 1000$ kg/m³

Phantom section: Flat Section

Measurement Standard: DASY5 (IEEE/IEC/ANSI C63.19-2011)

DASY52 Configuration:

- Probe: ES3DV3 - SN3205; ConvF(6.17, 6.17, 6.17); Calibrated: 30.12.2014;
- Sensor-Surface: 3mm (Mechanical Surface Detection)
- Electronics: DAE4 Sn601; Calibrated: 18.08.2014
- Phantom: Flat Phantom 4.9L; Type: QD000P49AA; Serial: 1001
- DASY52 52.8.8(1222); SEMCAD X 14.6.10(7331)

Dipole Calibration for Body Tissue/Pin=250 mW, d=15mm/Zoom Scan (7x7x7)/Cube 0:

Measurement grid: dx=5mm, dy=5mm, dz=5mm

Reference Value = 54.56 V/m; Power Drift = -0.02 dB

Peak SAR (extrapolated) = 3.50 W/kg

SAR(1 g) = 2.37 W/kg; SAR(10 g) = 1.55 W/kg

Maximum value of SAR (measured) = 2.77 W/kg

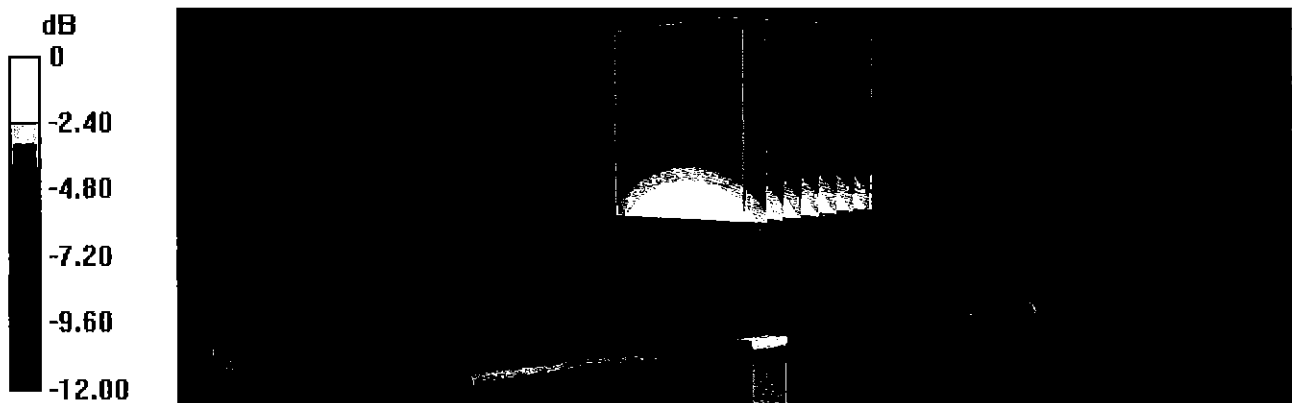

0 dB = 2.77 W/kg = 4.42 dBW/kg

Impedance Measurement Plot for Body TSL

23 Jul 2015 12:09:09

CH1 S11 1 U FS 1: 47.979 Ω -3.6699 Ω 51.937 pF 835.000 000 MHz

*
De1
CA
Avg
16
H1d

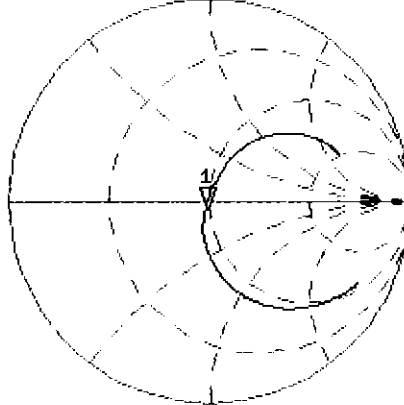

CH2 S11 LOG 5 dB/ REF -20 dB 1: -27.388 dB 835.000 000 MHz

De1
CA
Avg
16
H1d

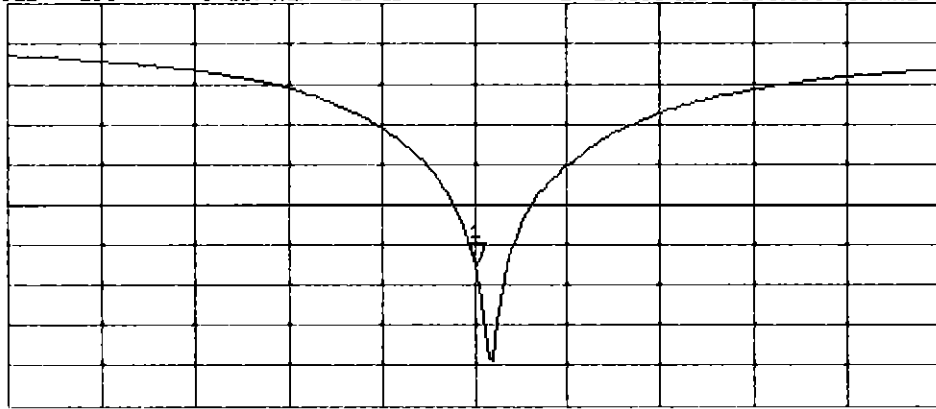

START 635.000 000 MHz

STOP 1 035.000 000 MHz



Accredited by the Swiss Accreditation Service (SAS)
The Swiss Accreditation Service is one of the signatories to the EA
Multilateral Agreement for the recognition of calibration certificates

Accreditation No.: **SCS 0108**

Client **PC Test**

Certificate No: **D1750V2-1051_Apr15**

CALIBRATION CERTIFICATE

Object **D1750V2 - SN:1051**

Calibration procedure(s) **QA CAL-05.v9
Calibration procedure for dipole validation kits above 700 MHz**

PM ✓
4/29/15

Calibration date: **April 15, 2015**

This calibration certificate documents the traceability to national standards, which realize the physical units of measurements (SI).
The measurements and the uncertainties with confidence probability are given on the following pages and are part of the certificate.

All calibrations have been conducted in the closed laboratory facility: environment temperature (22 ± 3)°C and humidity < 70%.

Calibration Equipment used (M&TE critical for calibration)

Primary Standards	ID #	Cal Date (Certificate No.)	Scheduled Calibration
Power meter EPM-442A	GB37480704	07-Oct-14 (No. 217-02020)	Oct-15
Power sensor HP 8481A	US37292783	07-Oct-14 (No. 217-02020)	Oct-15
Power sensor HP 8481A	MY41092317	07-Oct-14 (No. 217-02021)	Oct-15
Reference 20 dB Attenuator	SN: 5058 (20k)	01-Apr-15 (No. 217-02131)	Mar-16
Type-N mismatch combination	SN: 5047.2 / 06327	01-Apr-15 (No. 217-02134)	Mar-16
Reference Probe ES3DV3	SN: 3205	30-Dec-14 (No. ES3-3205_Dec14)	Dec-15
DAE4	SN: 601	18-Aug-14 (No. DAE4-601_Aug14)	Aug-15
Secondary Standards	ID #	Check Date (in house)	Scheduled Check
RF generator R&S SMT-06	100005	04-Aug-99 (in house check Oct-13)	In house check: Oct-16
Network Analyzer HP 8753E	US37390585 S4206	18-Oct-01 (in house check Oct-14)	In house check: Oct-15

Calibrated by: **Jeton Kastrati** (Name), **Laboratory Technician** (Function), [Signature]
Approved by: **Katja Pokovic** (Name), **Technical Manager** (Function), [Signature]

Issued: April 15, 2015

This calibration certificate shall not be reproduced except in full without written approval of the laboratory.



Accredited by the Swiss Accreditation Service (SAS)
The Swiss Accreditation Service is one of the signatories to the EA
Multilateral Agreement for the recognition of calibration certificates

Accreditation No.: **SCS 0108**

Glossary:

TSL	tissue simulating liquid
ConvF	sensitivity in TSL / NORM x,y,z
N/A	not applicable or not measured

Calibration is Performed According to the Following Standards:

- a) IEEE Std 1528-2013, "IEEE Recommended Practice for Determining the Peak Spatial-Averaged Specific Absorption Rate (SAR) in the Human Head from Wireless Communications Devices: Measurement Techniques", June 2013
- b) IEC 62209-1, "Procedure to measure the Specific Absorption Rate (SAR) for hand-held devices used in close proximity to the ear (frequency range of 300 MHz to 3 GHz)", February 2005
- c) KDB 865664, "SAR Measurement Requirements for 100 MHz to 6 GHz"

Additional Documentation:

- d) DASY4/5 System Handbook

Methods Applied and Interpretation of Parameters:

- *Measurement Conditions:* Further details are available from the Validation Report at the end of the certificate. All figures stated in the certificate are valid at the frequency indicated.
- *Antenna Parameters with TSL:* The dipole is mounted with the spacer to position its feed point exactly below the center marking of the flat phantom section, with the arms oriented parallel to the body axis.
- *Feed Point Impedance and Return Loss:* These parameters are measured with the dipole positioned under the liquid filled phantom. The impedance stated is transformed from the measurement at the SMA connector to the feed point. The Return Loss ensures low reflected power. No uncertainty required.
- *Electrical Delay:* One-way delay between the SMA connector and the antenna feed point. No uncertainty required.
- *SAR measured:* SAR measured at the stated antenna input power.
- *SAR normalized:* SAR as measured, normalized to an input power of 1 W at the antenna connector.
- *SAR for nominal TSL parameters:* The measured TSL parameters are used to calculate the nominal SAR result.

The reported uncertainty of measurement is stated as the standard uncertainty of measurement multiplied by the coverage factor $k=2$, which for a normal distribution corresponds to a coverage probability of approximately 95%.

Measurement Conditions

DASY system configuration, as far as not given on page 1.

DASY Version	DASY5	V52.8.8
Extrapolation	Advanced Extrapolation	
Phantom	Modular Flat Phantom	
Distance Dipole Center - TSL	10 mm	with Spacer
Zoom Scan Resolution	dx, dy, dz = 5 mm	
Frequency	1750 MHz ± 1 MHz	

Head TSL parameters

The following parameters and calculations were applied.

	Temperature	Permittivity	Conductivity
Nominal Head TSL parameters	22.0 °C	40.1	1.37 mho/m
Measured Head TSL parameters	(22.0 ± 0.2) °C	38.9 ± 6 %	1.35 mho/m ± 6 %
Head TSL temperature change during test	< 0.5 °C	----	----

SAR result with Head TSL

SAR averaged over 1 cm ³ (1 g) of Head TSL	Condition	
SAR measured	250 mW input power	9.04 W/kg
SAR for nominal Head TSL parameters	normalized to 1W	36.2 W/kg ± 17.0 % (k=2)

SAR averaged over 10 cm ³ (10 g) of Head TSL	condition	
SAR measured	250 mW input power	4.80 W/kg
SAR for nominal Head TSL parameters	normalized to 1W	19.2 W/kg ± 16.5 % (k=2)

Body TSL parameters

The following parameters and calculations were applied.

	Temperature	Permittivity	Conductivity
Nominal Body TSL parameters	22.0 °C	53.4	1.49 mho/m
Measured Body TSL parameters	(22.0 ± 0.2) °C	51.5 ± 6 %	1.48 mho/m ± 6 %
Body TSL temperature change during test	< 0.5 °C	----	----

SAR result with Body TSL

SAR averaged over 1 cm ³ (1 g) of Body TSL	Condition	
SAR measured	250 mW input power	9.32 W/kg
SAR for nominal Body TSL parameters	normalized to 1W	37.1 W/kg ± 17.0 % (k=2)

SAR averaged over 10 cm ³ (10 g) of Body TSL	condition	
SAR measured	250 mW input power	5.01 W/kg
SAR for nominal Body TSL parameters	normalized to 1W	20.0 W/kg ± 16.5 % (k=2)

Appendix (Additional assessments outside the scope of SCS 0108)

Antenna Parameters with Head TSL

Impedance, transformed to feed point	51.3 Ω - 0.2 j Ω
Return Loss	- 37.5 dB

Antenna Parameters with Body TSL

Impedance, transformed to feed point	46.9 Ω + 0.3 j Ω
Return Loss	- 29.9 dB

General Antenna Parameters and Design

Electrical Delay (one direction)	1.221 ns
----------------------------------	----------

After long term use with 100W radiated power, only a slight warming of the dipole near the feedpoint can be measured.

The dipole is made of standard semirigid coaxial cable. The center conductor of the feeding line is directly connected to the second arm of the dipole. The antenna is therefore short-circuited for DC-signals. On some of the dipoles, small end caps are added to the dipole arms in order to improve matching when loaded according to the position as explained in the "Measurement Conditions" paragraph. The SAR data are not affected by this change. The overall dipole length is still according to the Standard.

No excessive force must be applied to the dipole arms, because they might bend or the soldered connections near the feedpoint may be damaged.

Additional EUT Data

Manufactured by	SPEAG
Manufactured on	February 19, 2010

DASY5 Validation Report for Head TSL

Date: 15.04.2015

Test Laboratory: SPEAG, Zurich, Switzerland

DUT: Dipole 1750 MHz; Type: D1750V2; Serial: D1750V2 - SN:1051

Communication System: UID 0 - CW; Frequency: 1750 MHz

Medium parameters used: $f = 1750$ MHz; $\sigma = 1.35$ S/m; $\epsilon_r = 38.9$; $\rho = 1000$ kg/m³

Phantom section: Flat Section

Measurement Standard: DASY5 (IEEE/IEC/ANSI C63.19-2011)

DASY52 Configuration:

- Probe: ES3DV3 - SN3205; ConvF(5.2, 5.2, 5.2); Calibrated: 30.12.2014;
- Sensor-Surface: 3mm (Mechanical Surface Detection)
- Electronics: DAE4 Sn601; Calibrated: 18.08.2014
- Phantom: Flat Phantom 5.0 (front); Type: QD000P50AA; Serial: 1001
- DASY52 52.8.8(1222); SEMCAD X 14.6.10(7331)

Dipole Calibration for Head Tissue/Pin=250 mW, d=10mm/Zoom Scan (7x7x7)/Cube 0:

Measurement grid: dx=5mm, dy=5mm, dz=5mm

Reference Value = 94.99 V/m; Power Drift = 0.06 dB

Peak SAR (extrapolated) = 16.3 W/kg

SAR(1 g) = 9.04 W/kg; SAR(10 g) = 4.8 W/kg

Maximum value of SAR (measured) = 11.5 W/kg

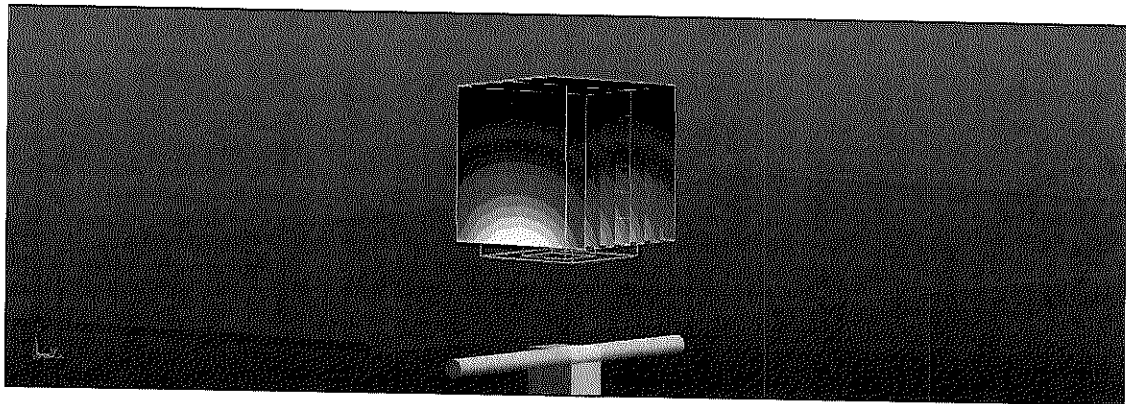
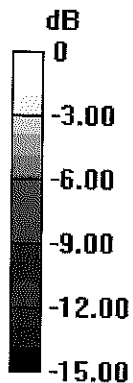

0 dB = 11.5 W/kg = 10.61 dBW/kg

Impedance Measurement Plot for Head TSL

[CH1] S11 1 U FS 15 Apr 2015 12:25:31
 3: 51.330 Ω -248.05 m Ω 366.65 pF 1 750.000 000 MHz

*
 Del
 C Δ
 Avg
 16
 H1d

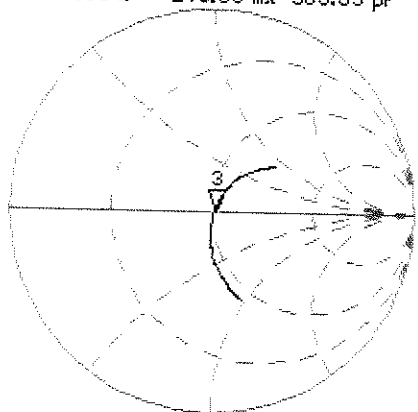

CH2 S11 LOG 5 dB/REF -20 dB 3: -37.470 dB 1 750.000 000 MHz

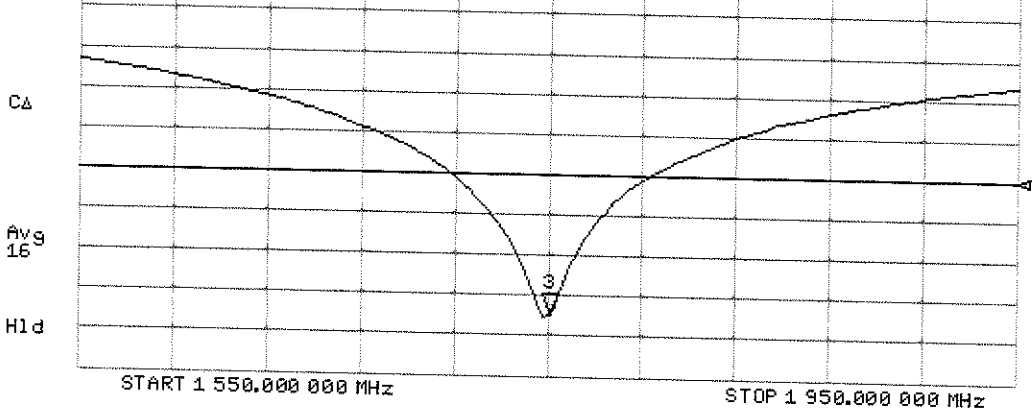

DASY5 Validation Report for Body TSL

Date: 15.04.2015

Test Laboratory: SPEAG, Zurich, Switzerland

DUT: Dipole 1750 MHz; Type: D1750V2; Serial: D1750V2 - SN:1051

Communication System: UID 0 - CW; Frequency: 1750 MHz

Medium parameters used: $f = 1750$ MHz; $\sigma = 1.48$ S/m; $\epsilon_r = 51.5$; $\rho = 1000$ kg/m³

Phantom section: Flat Section

Measurement Standard: DASY5 (IEEE/IEC/ANSI C63.19-2011)

DASY52 Configuration:

- Probe: ES3DV3 - SN3205; ConvF(4.88, 4.88, 4.88); Calibrated: 30.12.2014;
- Sensor-Surface: 3mm (Mechanical Surface Detection)
- Electronics: DAE4 Sn601; Calibrated: 18.08.2014
- Phantom: Flat Phantom 5.0 (back); Type: QD000P50AA; Serial: 1002
- DASY52 52.8.8(1222); SEMCAD X 14.6.10(7331)

Dipole Calibration for Body Tissue/Pin=250 mW, d=10mm/Zoom Scan (7x7x7)/Cube 0:

Measurement grid: dx=5mm, dy=5mm, dz=5mm

Reference Value = 92.87 V/m; Power Drift = 0.01 dB

Peak SAR (extrapolated) = 16.0 W/kg

SAR(1 g) = 9.32 W/kg; SAR(10 g) = 5.01 W/kg

Maximum value of SAR (measured) = 11.7 W/kg

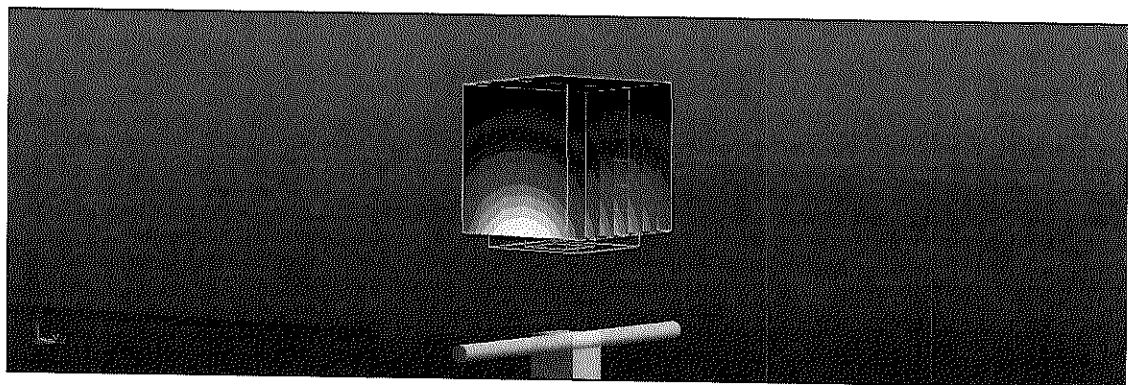
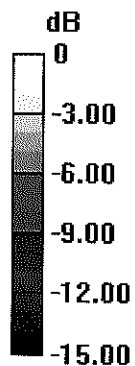

0 dB = 11.7 W/kg = 10.68 dBW/kg

Impedance Measurement Plot for Body TSL

15 Apr 2015 12:23:57
 [CH1] S11 1 U FS 3: 46.930 Ω 0.3242 Ω 29.486 pF 1 750.000 000 MHz

 De1
 Ca
 Avg
 16
 H1d

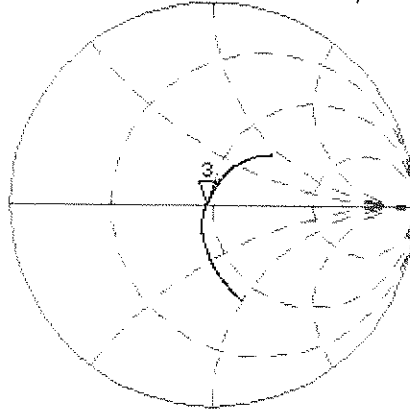

CH2 S11 LOG 5 dB/REF -20 dB 3:-29.939 dB 1 750.000 000 MHz

Ca
 Avg
 16
 H1d

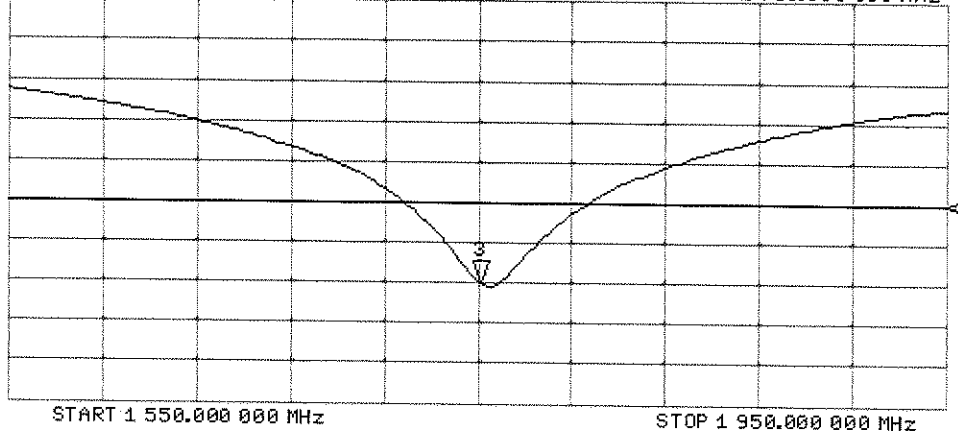



Accredited by the Swiss Accreditation Service (SAS)
The Swiss Accreditation Service is one of the signatories to the EA
Multilateral Agreement for the recognition of calibration certificates

Accreditation No.: **SCS 0108**

Client **PC Test**

Certificate No: **D1765V2-1008_May15**

CALIBRATION CERTIFICATE

Object **D1765V2 - SN: 1008**

Calibration procedure(s) **QA CAL-05.v9**
Calibration procedure for dipole validation kits above 700 MHz

CCV
5/28/15

Calibration date: **May 13, 2015**

This calibration certificate documents the traceability to national standards, which realize the physical units of measurements (SI).
The measurements and the uncertainties with confidence probability are given on the following pages and are part of the certificate.

All calibrations have been conducted in the closed laboratory facility: environment temperature (22 ± 3)°C and humidity < 70%.

Calibration Equipment used (M&TE critical for calibration)

Primary Standards	ID #	Cal Date (Certificate No.)	Scheduled Calibration
Power meter EPM-442A	GB37480704	07-Oct-14 (No. 217-02020)	Oct-15
Power sensor HP 8481A	US37292783	07-Oct-14 (No. 217-02020)	Oct-15
Power sensor HP 8481A	MY41092317	07-Oct-14 (No. 217-02021)	Oct-15
Reference 20 dB Attenuator	SN: 5058 (20k)	01-Apr-15 (No. 217-02131)	Mar-16
Type-N mismatch combination	SN: 5047.2 / 06327	01-Apr-15 (No. 217-02134)	Mar-16
Reference Probe ES3DV3	SN: 3205	30-Dec-14 (No. ES3-3205_Dec14)	Dec-15
DAE4	SN: 601	18-Aug-14 (No. DAE4-601_Aug14)	Aug-15

Secondary Standards	ID #	Check Date (in house)	Scheduled Check
RF generator R&S SMT-06	100005	04-Aug-99 (in house check Oct-13)	In house check: Oct-16
Network Analyzer HP 8753E	US37390585 S4206	18-Oct-01 (in house check Oct-14)	In house check: Oct-15

Calibrated by: **Michael Weber** Name: **Michael Weber** Function: **Laboratory Technician**

Signature

M. Weber

Approved by: **Katja Pokovic** Name: **Katja Pokovic** Technical Manager

Katja Pokovic

Issued: May 15, 2015

This calibration certificate shall not be reproduced except in full without written approval of the laboratory.



Accredited by the Swiss Accreditation Service (SAS)
The Swiss Accreditation Service is one of the signatories to the EA
Multilateral Agreement for the recognition of calibration certificates

Accreditation No.: **SCS 0108**

Glossary:

TSL	tissue simulating liquid
ConvF	sensitivity in TSL / NORM x,y,z
N/A	not applicable or not measured

Calibration is Performed According to the Following Standards:

- a) IEEE Std 1528-2013, "IEEE Recommended Practice for Determining the Peak Spatial-Averaged Specific Absorption Rate (SAR) in the Human Head from Wireless Communications Devices: Measurement Techniques", June 2013
- b) IEC 62209-1, "Procedure to measure the Specific Absorption Rate (SAR) for hand-held devices used in close proximity to the ear (frequency range of 300 MHz to 3 GHz)", February 2005
- c) KDB 865664, "SAR Measurement Requirements for 100 MHz to 6 GHz"

Additional Documentation:

- d) DASY4/5 System Handbook

Methods Applied and Interpretation of Parameters:

- *Measurement Conditions:* Further details are available from the Validation Report at the end of the certificate. All figures stated in the certificate are valid at the frequency indicated.
- *Antenna Parameters with TSL:* The dipole is mounted with the spacer to position its feed point exactly below the center marking of the flat phantom section, with the arms oriented parallel to the body axis.
- *Feed Point Impedance and Return Loss:* These parameters are measured with the dipole positioned under the liquid filled phantom. The impedance stated is transformed from the measurement at the SMA connector to the feed point. The Return Loss ensures low reflected power. No uncertainty required.
- *Electrical Delay:* One-way delay between the SMA connector and the antenna feed point. No uncertainty required.
- *SAR measured:* SAR measured at the stated antenna input power.
- *SAR normalized:* SAR as measured, normalized to an input power of 1 W at the antenna connector.
- *SAR for nominal TSL parameters:* The measured TSL parameters are used to calculate the nominal SAR result.

The reported uncertainty of measurement is stated as the standard uncertainty of measurement multiplied by the coverage factor $k=2$, which for a normal distribution corresponds to a coverage probability of approximately 95%.

Measurement Conditions

DASY system configuration, as far as not given on page 1.

DASY Version	DASY5	V52.8.8
Extrapolation	Advanced Extrapolation	
Phantom	Modular Flat Phantom	
Distance Dipole Center - TSL	10 mm	with Spacer
Zoom Scan Resolution	dx, dy, dz = 5 mm	
Frequency	1750 MHz \pm 1 MHz	

Head TSL parameters

The following parameters and calculations were applied.

	Temperature	Permittivity	Conductivity
Nominal Head TSL parameters	22.0 °C	40.1	1.38 mho/m
Measured Head TSL parameters	(22.0 \pm 0.2) °C	39.0 \pm 6 %	1.37 mho/m \pm 6 %
Head TSL temperature change during test	< 0.5 °C	----	----

SAR result with Head TSL

SAR averaged over 1 cm ³ (1 g) of Head TSL	Condition	
SAR measured	250 mW input power	9.45 W/kg
SAR for nominal Head TSL parameters	normalized to 1W	37.7 W/kg \pm 17.0 % (k=2)

SAR averaged over 10 cm ³ (10 g) of Head TSL	condition	
SAR measured	250 mW input power	5.02 W/kg
SAR for nominal Head TSL parameters	normalized to 1W	20.1 W/kg \pm 16.5 % (k=2)

Body TSL parameters

The following parameters and calculations were applied.

	Temperature	Permittivity	Conductivity
Nominal Body TSL parameters	22.0 °C	53.4	1.50 mho/m
Measured Body TSL parameters	(22.0 \pm 0.2) °C	51.5 \pm 6 %	1.49 mho/m \pm 6 %
Body TSL temperature change during test	< 0.5 °C	----	----

SAR result with Body TSL

SAR averaged over 1 cm ³ (1 g) of Body TSL	Condition	
SAR measured	250 mW input power	9.55 W/kg
SAR for nominal Body TSL parameters	normalized to 1W	38.0 W/kg \pm 17.0 % (k=2)

SAR averaged over 10 cm ³ (10 g) of Body TSL	condition	
SAR measured	250 mW input power	5.12 W/kg
SAR for nominal Body TSL parameters	normalized to 1W	20.4 W/kg \pm 16.5 % (k=2)

Appendix (Additional assessments outside the scope of SCS 0108)

Antenna Parameters with Head TSL

Impedance, transformed to feed point	48.5 Ω - 4.6 j Ω
Return Loss	- 26.2 dB

Antenna Parameters with Body TSL

Impedance, transformed to feed point	44.8 Ω - 5.3 j Ω
Return Loss	- 22.1 dB

General Antenna Parameters and Design

Electrical Delay (one direction)	1.211 ns
----------------------------------	----------

After long term use with 100W radiated power, only a slight warming of the dipole near the feedpoint can be measured.

The dipole is made of standard semirigid coaxial cable. The center conductor of the feeding line is directly connected to the second arm of the dipole. The antenna is therefore short-circuited for DC-signals. On some of the dipoles, small end caps are added to the dipole arms in order to improve matching when loaded according to the position as explained in the "Measurement Conditions" paragraph. The SAR data are not affected by this change. The overall dipole length is still according to the Standard.

No excessive force must be applied to the dipole arms, because they might bend or the soldered connections near the feedpoint may be damaged.

Additional EUT Data

Manufactured by	SPEAG
Manufactured on	October 06, 2005

DASY5 Validation Report for Head TSL

Date: 13.05.2015

Test Laboratory: SPEAG, Zurich, Switzerland

DUT: Dipole 1765 MHz; Type: D1765V2; Serial: D1765V2 - SN: 1008

Communication System: UID 0 - CW; Frequency: 1750 MHz

Medium parameters used: $f = 1750$ MHz; $\sigma = 1.37$ S/m; $\epsilon_r = 39$; $\rho = 1000$ kg/m³

Phantom section: Flat Section

Measurement Standard: DASY5 (IEEE/IEC/ANSI C63.19-2007)

DASY52 Configuration:

- Probe: ES3DV3 - SN3205; ConvF(5.2, 5.2, 5.2); Calibrated: 30.12.2014;
- Sensor-Surface: 3mm (Mechanical Surface Detection)
- Electronics: DAE4 Sn601; Calibrated: 18.08.2014
- Phantom: Flat Phantom 5.0 (front); Type: QD000P50AA; Serial: 1001
- DASY52 52.8.8(1222); SEMCAD X 14.6.10(7331)

Dipole Calibration for Head Tissue/Pin=250 mW, d=10mm/Zoom Scan (7x7x7)/Cube 0:

Measurement grid: dx=5mm, dy=5mm, dz=5mm

Reference Value = 96.56 V/m; Power Drift = 0.00 dB

Peak SAR (extrapolated) = 17.0 W/kg

SAR(1 g) = 9.45 W/kg; SAR(10 g) = 5.02 W/kg

Maximum value of SAR (measured) = 11.9 W/kg

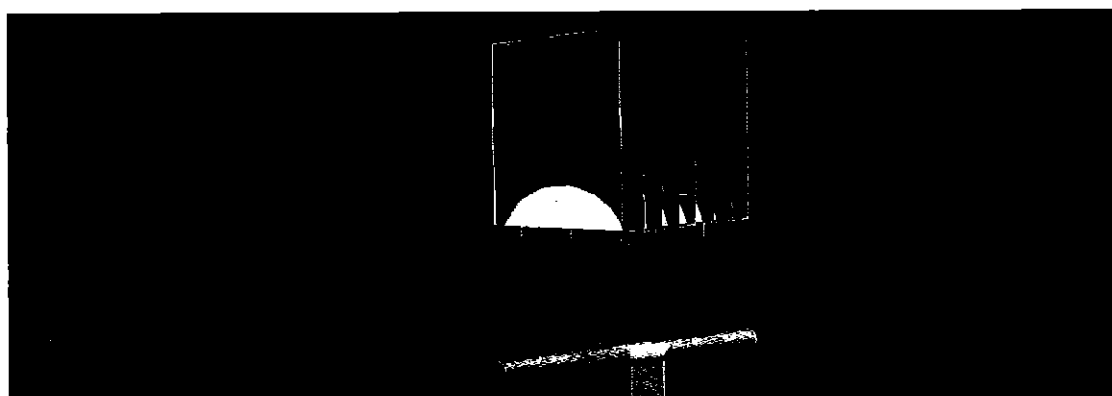
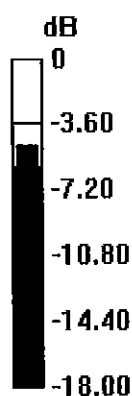

0 dB = 11.9 W/kg = 10.76 dBW/kg

Impedance Measurement Plot for Head TSL

13 May 2015 09:57:41

CH1 S11 1 U FS 1: 48.541 Ω -4.5820 Ω 19.848 pF 1 750.000 000 MHz

*
De1
CA
Avg
16
H1d

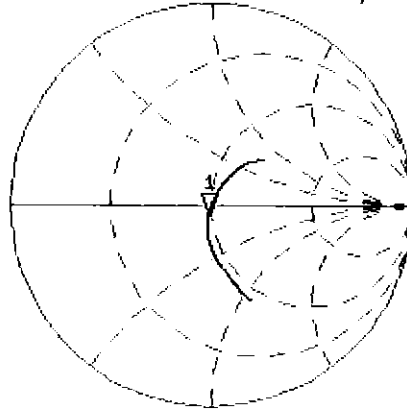

CH2 S11 LOG 5 dB/REF -20 dB 1:-26.240 dB 1 750.000 000 MHz

De1
CA
Avg
16
H1d

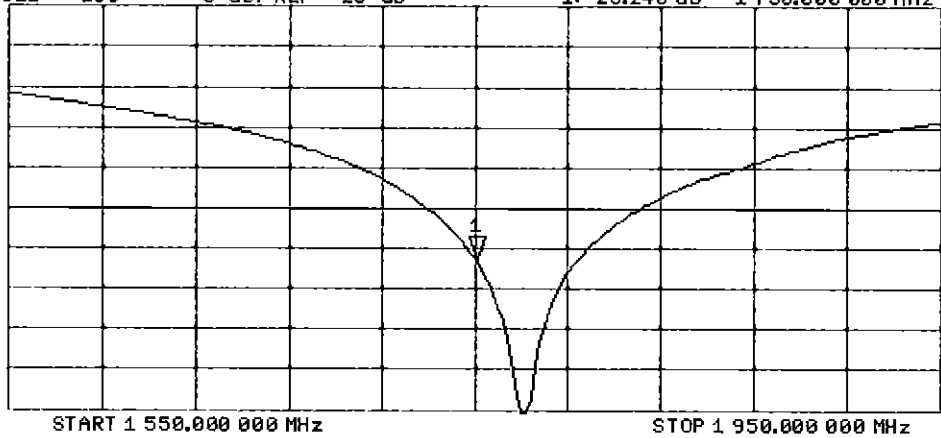

DASY5 Validation Report for Body TSL

Date: 13.05.2015

Test Laboratory: SPEAG, Zurich, Switzerland

DUT: Dipole 1765 MHz; Type: D1765V2; Serial: D1765V2 - SN: 1008

Communication System: UID 0 - CW; Frequency: 1750 MHz

Medium parameters used: $f = 1750 \text{ MHz}$; $\sigma = 1.49 \text{ S/m}$; $\epsilon_r = 51.5$; $\rho = 1000 \text{ kg/m}^3$

Phantom section: Flat Section

Measurement Standard: DASY5 (IEEE/IEC/ANSI C63.19-2007)

DASY52 Configuration:

- Probe: ES3DV3 - SN3205; ConvF(4.88, 4.88, 4.88); Calibrated: 30.12.2014;
- Sensor-Surface: 3mm (Mechanical Surface Detection)
- Electronics: DAE4 Sn601; Calibrated: 18.08.2014
- Phantom: Flat Phantom 5.0 (back); Type: QD000P50AA; Serial: 1002
- DASY52 52.8.8(1222); SEMCAD X 14.6.10(7331)

Dipole Calibration for Body Tissue/Pin=250 mW, d=10mm/Zoom Scan (7x7x7)/Cube 0:

Measurement grid: $dx=5\text{mm}$, $dy=5\text{mm}$, $dz=5\text{mm}$

Reference Value = 93.70 V/m; Power Drift = -0.00 dB

Peak SAR (extrapolated) = 16.5 W/kg

SAR(1 g) = 9.55 W/kg; SAR(10 g) = 5.12 W/kg

Maximum value of SAR (measured) = 12.0 W/kg



0 dB = 12.0 W/kg = 10.79 dBW/kg

Impedance Measurement Plot for Body TSL

13 May 2015 09:57:07

[CH1] S11 1 U FS 1i 44.771 Ω -5.3477 Ω 17.007 pF 1 750.000 000 MHz

*
De l
CA
Avg
16

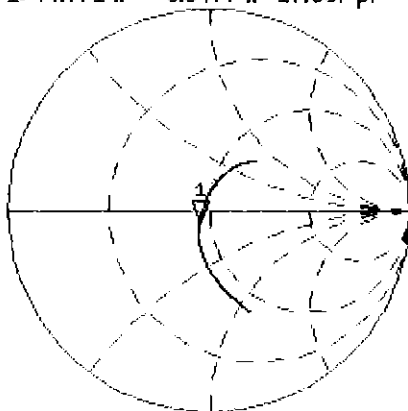

H1 d

CH2 S11 LOG 5 dB/REF -20 dB 1i -22.073 dB 1 750.000 000 MHz

De l
CA
Avg
16
H1 d

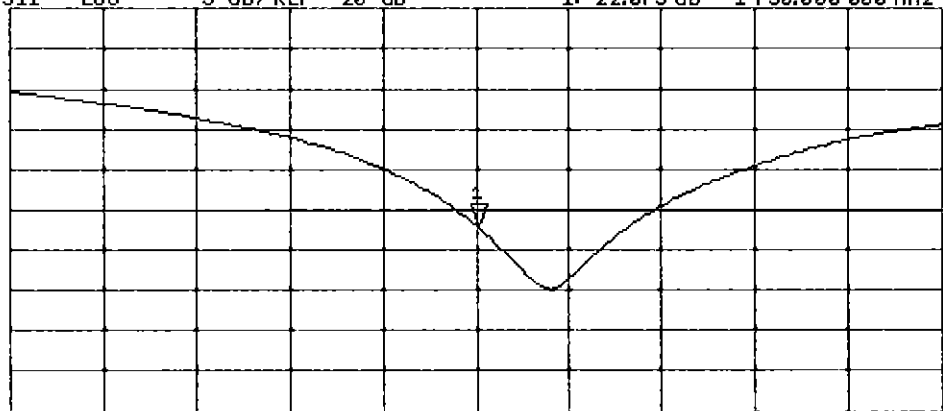

START 1 550.000 000 MHz

STOP 1 950.000 000 MHz



Accredited by the Swiss Accreditation Service (SAS)
The Swiss Accreditation Service is one of the signatories to the EA
Multilateral Agreement for the recognition of calibration certificates

Accreditation No.: **SCS 0108**

Client **PC Test**

Certificate No: **D1900V2-5d148_Feb16**

CALIBRATION CERTIFICATE

Object **D1900V2 - SN:5d148**

Calibration procedure(s) **QA CAL-05.v9
Calibration procedure for dipole validation kits above 700 MHz**

Calibration date: **February 19, 2016**

*BN ✓
3/1/2016*

This calibration certificate documents the traceability to national standards, which realize the physical units of measurements (SI).
The measurements and the uncertainties with confidence probability are given on the following pages and are part of the certificate.

All calibrations have been conducted in the closed laboratory facility: environment temperature (22 ± 3)°C and humidity < 70%.

Calibration Equipment used (M&TE critical for calibration)

Primary Standards	ID #	Cal Date (Certificate No.)	Scheduled Calibration
Power meter EPM-442A	GB37480704	07-Oct-15 (No. 217-02222)	Oct-16
Power sensor HP 8481A	US37292783	07-Oct-15 (No. 217-02222)	Oct-16
Power sensor HP 8481A	MY41092317	07-Oct-15 (No. 217-02223)	Oct-16
Reference 20 dB Attenuator	SN: 5058 (20k)	01-Apr-15 (No. 217-02131)	Mar-16
Type-N mismatch combination	SN: 5047.2 / 06327	01-Apr-15 (No. 217-02134)	Mar-16
Reference Probe EX3DV4	SN: 7349	31-Dec-15 (No. EX3-7349_Dec15)	Dec-16
DAE4	SN: 601	30-Dec-15 (No. DAE4-601_Dec15)	Dec-16

Secondary Standards	ID #	Check Date (in house)	Scheduled Check
RF generator R&S SMT-06	100972	15-Jun-15 (in house check Jun-15)	In house check: Jun-18
Network Analyzer HP 8753E	US37390585 S4206	18-Oct-01 (in house check Oct-15)	In house check: Oct-16

Calibrated by: **Michael Weber** **Laboratory Technician**

Signature

M. Weber

Approved by: **Katja Pokovic** **Technical Manager**

Katja Pokovic

Issued: February 19, 2016

This calibration certificate shall not be reproduced except in full without written approval of the laboratory.



Accredited by the Swiss Accreditation Service (SAS)
The Swiss Accreditation Service is one of the signatories to the EA
Multilateral Agreement for the recognition of calibration certificates

Accreditation No.: **SCS 0108**

Glossary:

TSL	tissue simulating liquid
ConvF	sensitivity in TSL / NORM x,y,z
N/A	not applicable or not measured

Calibration is Performed According to the Following Standards:

- IEEE Std 1528-2013, "IEEE Recommended Practice for Determining the Peak Spatial-Averaged Specific Absorption Rate (SAR) in the Human Head from Wireless Communications Devices: Measurement Techniques", June 2013
- IEC 62209-1, "Procedure to measure the Specific Absorption Rate (SAR) for hand-held devices used in close proximity to the ear (frequency range of 300 MHz to 3 GHz)", February 2005
- IEC 62209-2, "Procedure to determine the Specific Absorption Rate (SAR) for wireless communication devices used in close proximity to the human body (frequency range of 30 MHz to 6 GHz)", March 2010
- KDB 865664, "SAR Measurement Requirements for 100 MHz to 6 GHz"

Additional Documentation:

- DASY4/5 System Handbook

Methods Applied and Interpretation of Parameters:

- Measurement Conditions:** Further details are available from the Validation Report at the end of the certificate. All figures stated in the certificate are valid at the frequency indicated.
- Antenna Parameters with TSL:** The dipole is mounted with the spacer to position its feed point exactly below the center marking of the flat phantom section, with the arms oriented parallel to the body axis.
- Feed Point Impedance and Return Loss:** These parameters are measured with the dipole positioned under the liquid filled phantom. The impedance stated is transformed from the measurement at the SMA connector to the feed point. The Return Loss ensures low reflected power. No uncertainty required.
- Electrical Delay:** One-way delay between the SMA connector and the antenna feed point. No uncertainty required.
- SAR measured:** SAR measured at the stated antenna input power.
- SAR normalized:** SAR as measured, normalized to an input power of 1 W at the antenna connector.
- SAR for nominal TSL parameters:** The measured TSL parameters are used to calculate the nominal SAR result.

The reported uncertainty of measurement is stated as the standard uncertainty of measurement multiplied by the coverage factor $k=2$, which for a normal distribution corresponds to a coverage probability of approximately 95%.

Measurement Conditions

DASY system configuration, as far as not given on page 1.

DASY Version	DASY5	V52.8.8
Extrapolation	Advanced Extrapolation	
Phantom	Modular Flat Phantom	
Distance Dipole Center - TSL	10 mm	with Spacer
Zoom Scan Resolution	dx, dy, dz = 5 mm	
Frequency	1900 MHz \pm 1 MHz	

Head TSL parameters

The following parameters and calculations were applied.

	Temperature	Permittivity	Conductivity
Nominal Head TSL parameters	22.0 °C	40.0	1.40 mho/m
Measured Head TSL parameters	(22.0 \pm 0.2) °C	41.3 \pm 6 %	1.40 mho/m \pm 6 %
Head TSL temperature change during test	< 0.5 °C	----	----

SAR result with Head TSL

SAR averaged over 1 cm³ (1 g) of Head TSL	Condition	
SAR measured	250 mW input power	9.91 W/kg
SAR for nominal Head TSL parameters	normalized to 1W	39.9 W/kg \pm 17.0 % (k=2)

SAR averaged over 10 cm³ (10 g) of Head TSL	condition	
SAR measured	250 mW input power	5.18 W/kg
SAR for nominal Head TSL parameters	normalized to 1W	20.8 W/kg \pm 16.5 % (k=2)

Body TSL parameters

The following parameters and calculations were applied.

	Temperature	Permittivity	Conductivity
Nominal Body TSL parameters	22.0 °C	53.3	1.52 mho/m
Measured Body TSL parameters	(22.0 \pm 0.2) °C	52.9 \pm 6 %	1.52 mho/m \pm 6 %
Body TSL temperature change during test	< 0.5 °C	----	----

SAR result with Body TSL

SAR averaged over 1 cm³ (1 g) of Body TSL	Condition	
SAR measured	250 mW input power	9.95 W/kg
SAR for nominal Body TSL parameters	normalized to 1W	39.7 W/kg \pm 17.0 % (k=2)

SAR averaged over 10 cm³ (10 g) of Body TSL	condition	
SAR measured	250 mW input power	5.25 W/kg
SAR for nominal Body TSL parameters	normalized to 1W	21.0 W/kg \pm 16.5 % (k=2)

Appendix (Additional assessments outside the scope of SCS 0108)

Antenna Parameters with Head TSL

Impedance, transformed to feed point	53.2 Ω + 6.6 j Ω
Return Loss	- 23.0 dB

Antenna Parameters with Body TSL

Impedance, transformed to feed point	49.1 Ω + 7.8 j Ω
Return Loss	- 22.0 dB

General Antenna Parameters and Design

Electrical Delay (one direction)	1.198 ns
----------------------------------	----------

After long term use with 100W radiated power, only a slight warming of the dipole near the feedpoint can be measured.

The dipole is made of standard semirigid coaxial cable. The center conductor of the feeding line is directly connected to the second arm of the dipole. The antenna is therefore short-circuited for DC-signals. On some of the dipoles, small end caps are added to the dipole arms in order to improve matching when loaded according to the position as explained in the "Measurement Conditions" paragraph. The SAR data are not affected by this change. The overall dipole length is still according to the Standard.

No excessive force must be applied to the dipole arms, because they might bend or the soldered connections near the feedpoint may be damaged.

Additional EUT Data

Manufactured by	SPEAG
Manufactured on	March 11, 2011

DASY5 Validation Report for Head TSL

Date: 19.02.2016

Test Laboratory: SPEAG, Zurich, Switzerland

DUT: Dipole 1900 MHz; Type: D1900V2; Serial: D1900V2 - SN:5d148

Communication System: UID 0 - CW; Frequency: 1900 MHz

Medium parameters used: $f = 1900$ MHz; $\sigma = 1.4$ S/m; $\epsilon_r = 41.3$; $\rho = 1000$ kg/m³

Phantom section: Flat Section

Measurement Standard: DASY5 (IEEE/IEC/ANSI C63.19-2011)

DASY52 Configuration:

- Probe: EX3DV4 - SN7349; ConvF(8.2, 8.2, 8.2); Calibrated: 31.12.2015;
- Sensor-Surface: 1.4mm (Mechanical Surface Detection)
- Electronics: DAE4 Sn601; Calibrated: 30.12.2015
- Phantom: Flat Phantom 5.0 (front); Type: QD000P50AA; Serial: 1001
- DASY52 52.8.8(1258); SEMCAD X 14.6.10(7372)

Dipole Calibration for Head Tissue/Pin=250 mW, d=10mm/Zoom Scan (7x7x7)/Cube 0:

Measurement grid: dx=5mm, dy=5mm, dz=5mm

Reference Value = 108.9 V/m; Power Drift = 0.03 dB

Peak SAR (extrapolated) = 18.2 W/kg

SAR(1 g) = 9.91 W/kg; SAR(10 g) = 5.18 W/kg

Maximum value of SAR (measured) = 15.2 W/kg

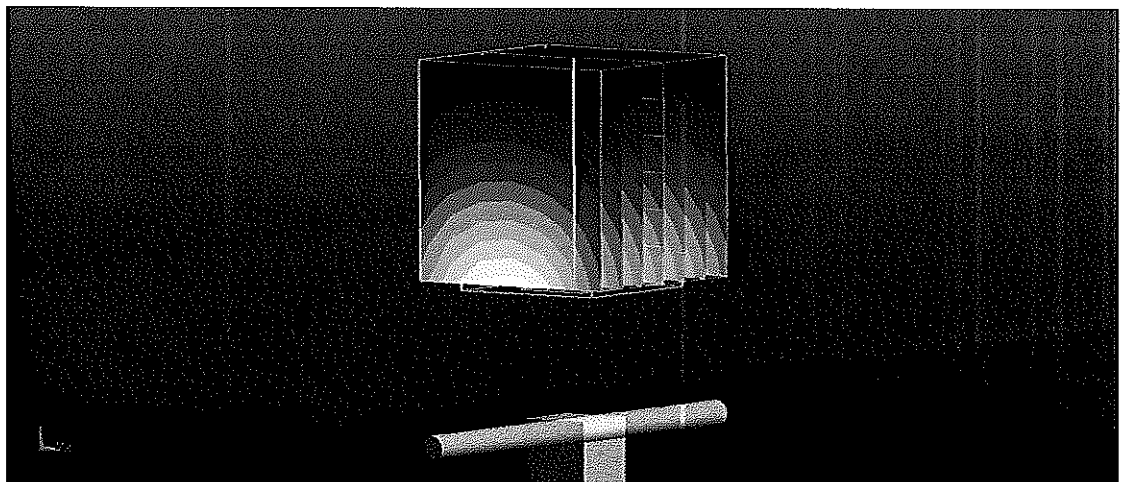
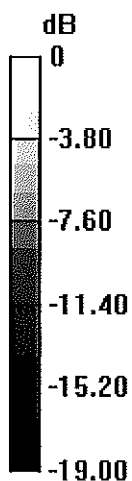

0 dB = 15.2 W/kg = 11.82 dBW/kg

Impedance Measurement Plot for Head TSL

19 Feb 2016 10:21:12

[CH1] S11 1 U FS 1: 53.234 Ω 6.5977 Ω 552.66 μ H 1 900.000 000 MHz

*
De1
Ca
Avg
16
H1d

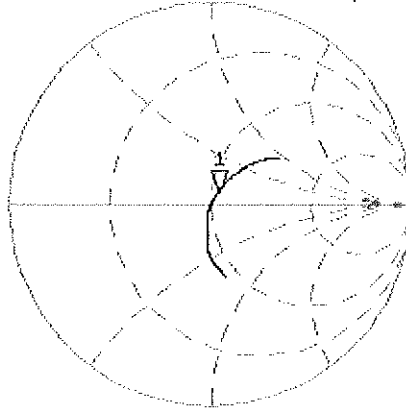

CH2 S11 LOG 5 dB/REF -20 dB 1:-22.968 dB 1 900.000 000 MHz

De1
Ca
Avg
16
H1d

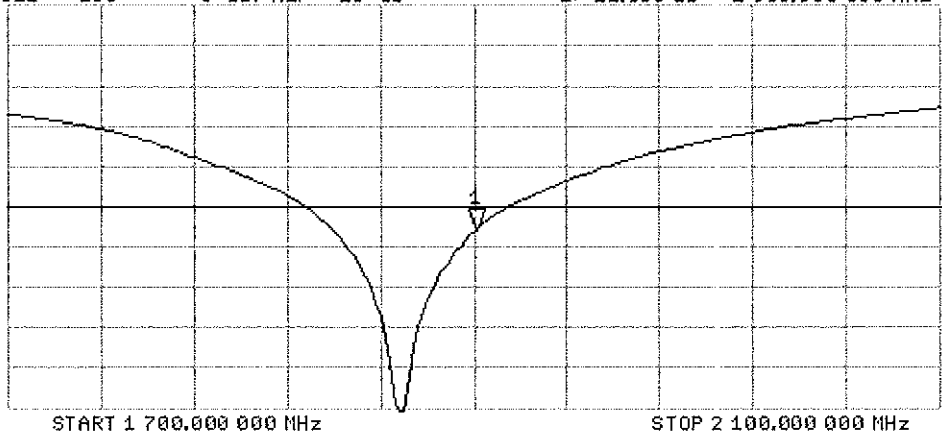

DASY5 Validation Report for Body TSL

Date: 19.02.2016

Test Laboratory: SPEAG, Zurich, Switzerland

DUT: Dipole 1900 MHz; Type: D1900V2; Serial: D1900V2 - SN:5d148

Communication System: UID 0 - CW; Frequency: 1900 MHz

Medium parameters used: $f = 1900$ MHz; $\sigma = 1.52$ S/m; $\epsilon_r = 52.9$; $\rho = 1000$ kg/m³

Phantom section: Flat Section

Measurement Standard: DASY5 (IEEE/IEC/ANSI C63.19-2011)

DASY52 Configuration:

- Probe: EX3DV4 - SN7349; ConvF(8.03, 8.03, 8.03); Calibrated: 31.12.2015;
- Sensor-Surface: 1.4mm (Mechanical Surface Detection)
- Electronics: DAE4 Sn601; Calibrated: 30.12.2015
- Phantom: Flat Phantom 5.0 (back); Type: QD000P50AA; Serial: 1002
- DASY52 52.8.8(1258); SEMCAD X 14.6.10(7372)

Dipole Calibration for Body Tissue/Pin=250 mW, d=10mm/Zoom Scan (7x7x7)/Cube 0:

Measurement grid: dx=5mm, dy=5mm, dz=5mm

Reference Value = 103.8 V/m; Power Drift = 0.02 dB

Peak SAR (extrapolated) = 17.5 W/kg

SAR(1 g) = 9.95 W/kg; SAR(10 g) = 5.25 W/kg

Maximum value of SAR (measured) = 15.0 W/kg

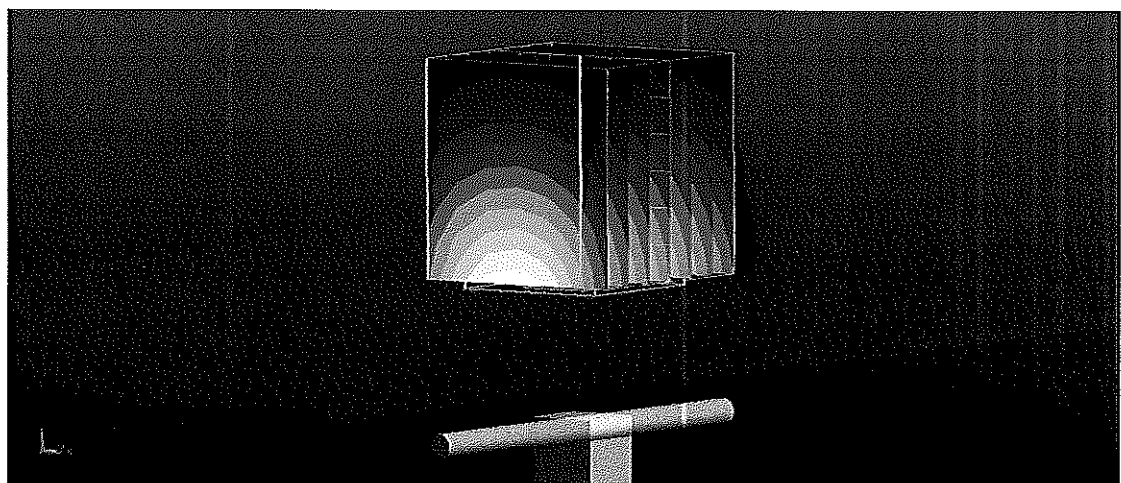
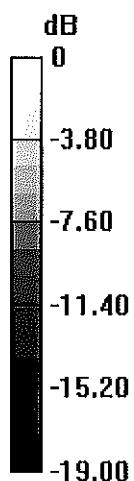

0 dB = 15.0 W/kg = 11.76 dBW/kg

Impedance Measurement Plot for Body TSL

19 Feb 2016 10:20:49

CH1 S11 1 U FS 1: 49.133 Ω 7.8340 Ω 656.22 μH 1 900.000 000 MHz

*
De1
CA
Avg
16
H1d

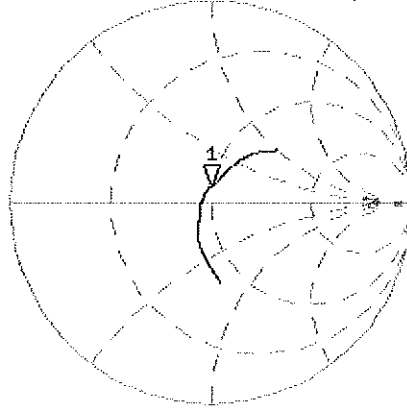

CH2 S11 LOG 5 dB/REF -20 dB 1:-22.018 dB 1 900.000 000 MHz

De1
CA
Avg
16
H1d

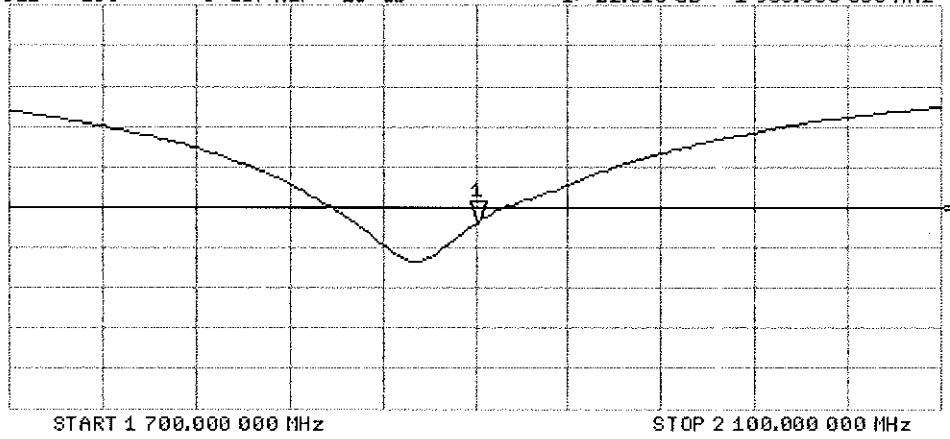



Accredited by the Swiss Accreditation Service (SAS)
The Swiss Accreditation Service is one of the signatories to the EA
Multilateral Agreement for the recognition of calibration certificates

Accreditation No.: **SCS 0108**

Client **PC Test**

Certificate No: **D1900V2-5d149_Jul15**

CALIBRATION CERTIFICATE

Object **D1900V2 - SN:5d149**

Calibration procedure(s) **QA CAL-05.v9
Calibration procedure for dipole validation kits above 700 MHz**

CCV
8/11/15

Calibration date: **July 14, 2015**

This calibration certificate documents the traceability to national standards, which realize the physical units of measurements (SI).
The measurements and the uncertainties with confidence probability are given on the following pages and are part of the certificate.

All calibrations have been conducted in the closed laboratory facility: environment temperature (22 ± 3)°C and humidity < 70%.

Calibration Equipment used (M&TE critical for calibration)

Primary Standards	ID #	Cal Date (Certificate No.)	Scheduled Calibration
Power meter EPM-442A	GB37480704	07-Oct-14 (No. 217-02020)	Oct-15
Power sensor HP 8481A	US37292783	07-Oct-14 (No. 217-02020)	Oct-15
Power sensor HP 8481A	MY41092317	07-Oct-14 (No. 217-02021)	Oct-15
Reference 20 dB Attenuator	SN: 5058 (20k)	01-Apr-15 (No. 217-02131)	Mar-16
Type-N mismatch combination	SN: 5047.2 / 06327	01-Apr-15 (No. 217-02134)	Mar-16
Reference Probe ES3DV3	SN: 3205	30-Dec-14 (No. ES3-3205_Dec14)	Dec-15
DAE4	SN: 601	18-Aug-14 (No. DAE4-601_Aug14)	Aug-15
Secondary Standards	ID #	Check Date (in house)	Scheduled Check
RF generator R&S SMT-06	100005	04-Aug-99 (in house check Oct-13)	In house check: Oct-16
Network Analyzer HP 8753E	US37390585 S4206	18-Oct-01 (in house check Oct-14)	In house check: Oct-15

Calibrated by: **Leif Klysnar** Name: **Leif Klysnar** Function: **Laboratory Technician**

Signature

Approved by: **Katja Pokovic** Name: **Katja Pokovic** Function: **Technical Manager**

Issued: July 14, 2015

This calibration certificate shall not be reproduced except in full without written approval of the laboratory.



Accredited by the Swiss Accreditation Service (SAS)
The Swiss Accreditation Service is one of the signatories to the EA
Multilateral Agreement for the recognition of calibration certificates

Accreditation No.: **SCS 0108**

Glossary:

TSL	tissue simulating liquid
ConvF	sensitivity in TSL / NORM x,y,z
N/A	not applicable or not measured

Calibration is Performed According to the Following Standards:

- a) IEEE Std 1528-2013, "IEEE Recommended Practice for Determining the Peak Spatial-Averaged Specific Absorption Rate (SAR) in the Human Head from Wireless Communications Devices: Measurement Techniques", June 2013
- b) IEC 62209-1, "Procedure to measure the Specific Absorption Rate (SAR) for hand-held devices used in close proximity to the ear (frequency range of 300 MHz to 3 GHz)", February 2005
- c) IEC 62209-2, "Procedure to determine the Specific Absorption Rate (SAR) for wireless communication devices used in close proximity to the human body (frequency range of 30 MHz to 6 GHz)", March 2010
- d) KDB 865664, "SAR Measurement Requirements for 100 MHz to 6 GHz"

Additional Documentation:

- e) DASY4/5 System Handbook

Methods Applied and Interpretation of Parameters:

- *Measurement Conditions:* Further details are available from the Validation Report at the end of the certificate. All figures stated in the certificate are valid at the frequency indicated.
- *Antenna Parameters with TSL:* The dipole is mounted with the spacer to position its feed point exactly below the center marking of the flat phantom section, with the arms oriented parallel to the body axis.
- *Feed Point Impedance and Return Loss:* These parameters are measured with the dipole positioned under the liquid filled phantom. The impedance stated is transformed from the measurement at the SMA connector to the feed point. The Return Loss ensures low reflected power. No uncertainty required.
- *Electrical Delay:* One-way delay between the SMA connector and the antenna feed point. No uncertainty required.
- *SAR measured:* SAR measured at the stated antenna input power.
- *SAR normalized:* SAR as measured, normalized to an input power of 1 W at the antenna connector.
- *SAR for nominal TSL parameters:* The measured TSL parameters are used to calculate the nominal SAR result.

The reported uncertainty of measurement is stated as the standard uncertainty of measurement multiplied by the coverage factor $k=2$, which for a normal distribution corresponds to a coverage probability of approximately 95%.

Measurement Conditions

DASY system configuration, as far as not given on page 1.

DASY Version	DASY5	V52.8.8
Extrapolation	Advanced Extrapolation	
Phantom	Modular Flat Phantom	
Distance Dipole Center - TSL	10 mm	with Spacer
Zoom Scan Resolution	dx, dy, dz = 5 mm	
Frequency	1900 MHz \pm 1 MHz	

Head TSL parameters

The following parameters and calculations were applied.

	Temperature	Permittivity	Conductivity
Nominal Head TSL parameters	22.0 °C	40.0	1.40 mho/m
Measured Head TSL parameters	(22.0 \pm 0.2) °C	39.7 \pm 6 %	1.38 mho/m \pm 6 %
Head TSL temperature change during test	< 0.5 °C	----	----

SAR result with Head TSL

SAR averaged over 1 cm ³ (1 g) of Head TSL	Condition	
SAR measured	250 mW input power	10.1 W/kg
SAR for nominal Head TSL parameters	normalized to 1W	40.7 W/kg \pm 17.0 % (k=2)

SAR averaged over 10 cm ³ (10 g) of Head TSL	condition	
SAR measured	250 mW input power	5.34 W/kg
SAR for nominal Head TSL parameters	normalized to 1W	21.5 W/kg \pm 16.5 % (k=2)

Body TSL parameters

The following parameters and calculations were applied.

	Temperature	Permittivity	Conductivity
Nominal Body TSL parameters	22.0 °C	53.3	1.52 mho/m
Measured Body TSL parameters	(22.0 \pm 0.2) °C	52.7 \pm 6 %	1.54 mho/m \pm 6 %
Body TSL temperature change during test	< 0.5 °C	----	----

SAR result with Body TSL

SAR averaged over 1 cm ³ (1 g) of Body TSL	Condition	
SAR measured	250 mW input power	10.2 W/kg
SAR for nominal Body TSL parameters	normalized to 1W	40.4 W/kg \pm 17.0 % (k=2)

SAR averaged over 10 cm ³ (10 g) of Body TSL	condition	
SAR measured	250 mW input power	5.49 W/kg
SAR for nominal Body TSL parameters	normalized to 1W	21.8 W/kg \pm 16.5 % (k=2)

Appendix (Additional assessments outside the scope of SCS 0108)

Antenna Parameters with Head TSL

Impedance, transformed to feed point	51.4 Ω + 5.6 j Ω
Return Loss	- 24.9 dB

Antenna Parameters with Body TSL

Impedance, transformed to feed point	47.7 Ω + 6.1 j Ω
Return Loss	- 23.5 dB

General Antenna Parameters and Design

Electrical Delay (one direction)	1.197 ns
----------------------------------	----------

After long term use with 100W radiated power, only a slight warming of the dipole near the feedpoint can be measured.

The dipole is made of standard semirigid coaxial cable. The center conductor of the feeding line is directly connected to the second arm of the dipole. The antenna is therefore short-circuited for DC-signals. On some of the dipoles, small end caps are added to the dipole arms in order to improve matching when loaded according to the position as explained in the "Measurement Conditions" paragraph. The SAR data are not affected by this change. The overall dipole length is still according to the Standard.

No excessive force must be applied to the dipole arms, because they might bend or the soldered connections near the feedpoint may be damaged.

Additional EUT Data

Manufactured by	SPEAG
Manufactured on	March 11, 2011

DASY5 Validation Report for Head TSL

Date: 14.07.2015

Test Laboratory: SPEAG, Zurich, Switzerland

DUT: Dipole 1900 MHz; Type: D1900V2; Serial: D1900V2 - SN:5d149

Communication System: UID 0 - CW; Frequency: 1900 MHz

Medium parameters used: $f = 1900$ MHz; $\sigma = 1.38$ S/m; $\epsilon_r = 39.7$; $\rho = 1000$ kg/m³

Phantom section: Flat Section

Measurement Standard: DASY5 (IEEE/IEC/ANSI C63.19-2011)

DASY52 Configuration:

- Probe: ES3DV3 - SN3205; ConvF(5, 5, 5); Calibrated: 30.12.2014;
- Sensor-Surface: 3mm (Mechanical Surface Detection)
- Electronics: DAE4 Sn601; Calibrated: 18.08.2014
- Phantom: Flat Phantom 5.0 (front); Type: QD000P50AA; Serial: 1001
- DASY52 52.8.8(1222); SEMCAD X 14.6.10(7331)

Dipole Calibration for Head Tissue/Pin=250 mW, d=10mm/Zoom Scan (7x7x7)/Cube 0:

Measurement grid: dx=5mm, dy=5mm, dz=5mm

Reference Value = 99.22 V/m; Power Drift = 0.02 dB

Peak SAR (extrapolated) = 18.3 W/kg

SAR(1 g) = 10.1 W/kg; SAR(10 g) = 5.34 W/kg

Maximum value of SAR (measured) = 12.9 W/kg

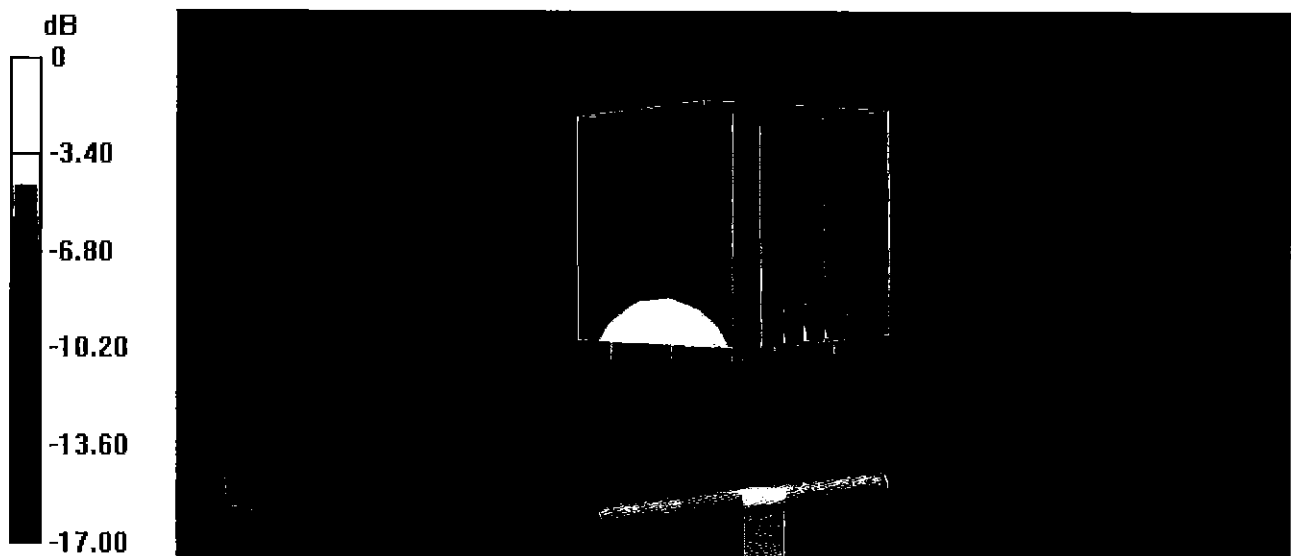

0 dB = 12.9 W/kg = 11.11 dBW/kg

Impedance Measurement Plot for Head TSL

14 Jul 2015 09:20:59

CH1 S11 1 U FS 1: 51.447 Ω 5.5664 Ω 466.27 μH 1 900.000 000 MHz

*
De1
Ca
Avg
16
H1d

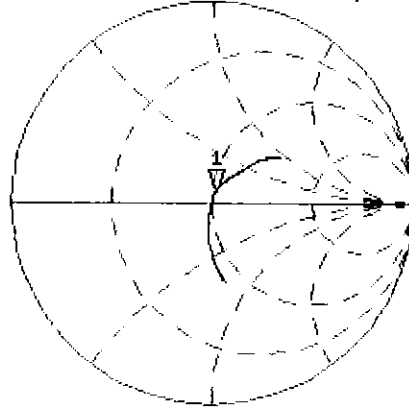

CH2 S11 LOG 5 dB/REF -20 dB 1:-24.943 dB 1 900.000 000 MHz

De1
Ca
Avg
16
H1d

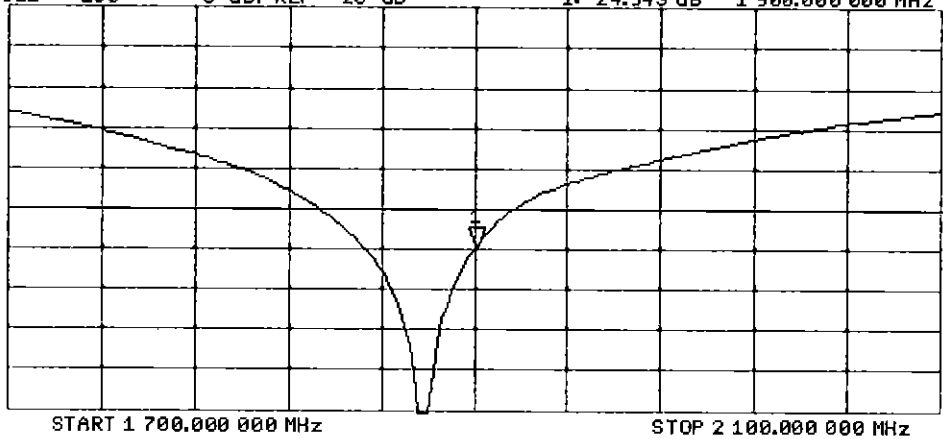

DASY5 Validation Report for Body TSL

Date: 14.07.2015

Test Laboratory: SPEAG, Zurich, Switzerland

DUT: Dipole 1900 MHz; Type: D1900V2; Serial: D1900V2 - SN:5d149

Communication System: UID 0 - CW; Frequency: 1900 MHz

Medium parameters used: $f = 1900$ MHz; $\sigma = 1.54$ S/m; $\epsilon_r = 52.7$; $\rho = 1000$ kg/m³

Phantom section: Flat Section

Measurement Standard: DASY5 (IEEE/IEC/ANSI C63.19-2011)

DASY52 Configuration:

- Probe: ES3DV3 - SN3205; ConvF(4.65, 4.65, 4.65); Calibrated: 30.12.2014;
- Sensor-Surface: 3mm (Mechanical Surface Detection)
- Electronics: DAE4 Sn601; Calibrated: 18.08.2014
- Phantom: Flat Phantom 5.0 (back); Type: QD000P50AA; Serial: 1002
- DASY52 52.8.8(1222); SEMCAD X 14.6.10(7331)

Dipole Calibration for Body Tissue/Pin=250 mW, d=10mm/Zoom Scan (7x7x7)/Cube 0:

Measurement grid: dx=5mm, dy=5mm, dz=5mm

Reference Value = 95.96 V/m; Power Drift = 0.01 dB

Peak SAR (extrapolated) = 17.2 W/kg

SAR(1 g) = 10.2 W/kg; SAR(10 g) = 5.49 W/kg

Maximum value of SAR (measured) = 12.9 W/kg

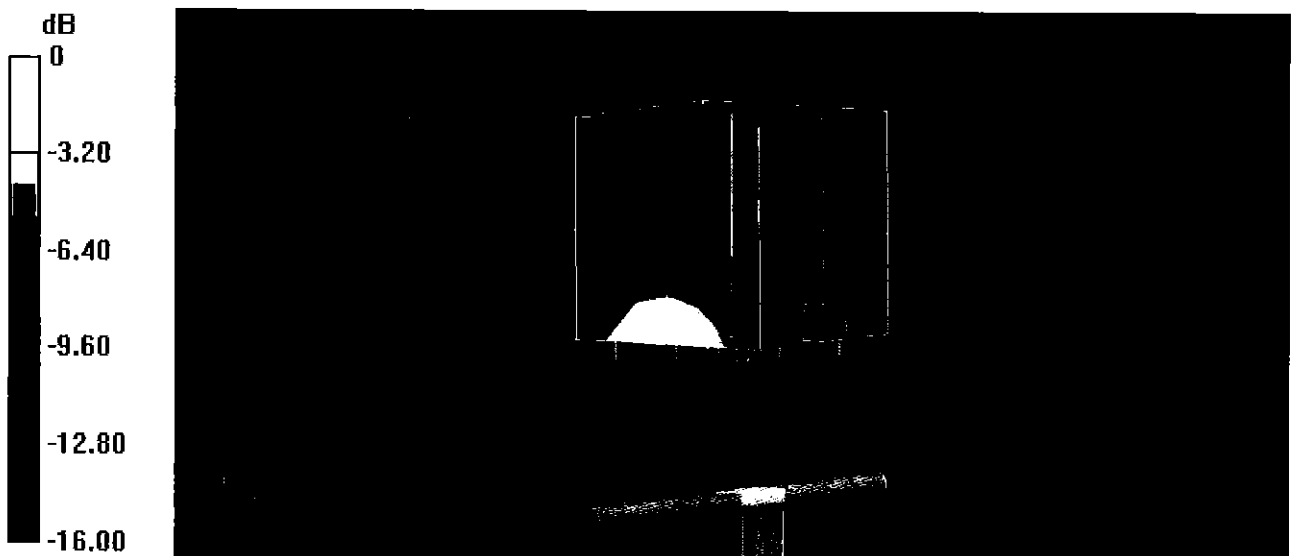

0 dB = 12.9 W/kg = 11.11 dBW/kg

Impedance Measurement Plot for Body TSL

14 Jul 2015 09:20:09

CH1 S11 1 U FS 1: 47.723 Ω 6.1406 Ω 514.37 μ H 1 900.000 000 MHz

*
Del
CA
Avg
16
H1d

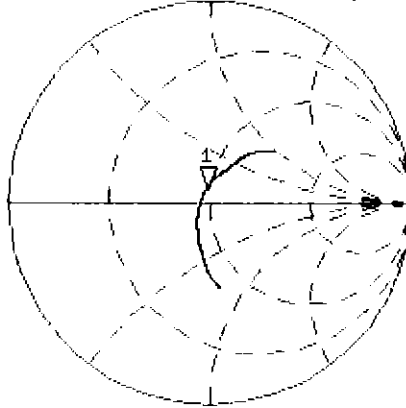

CH2 S11 LOG 5 dB/REF -20 dB 1:-23.490 dB 1 900.000 000 MHz

Del
CA
Avg
16
H1d

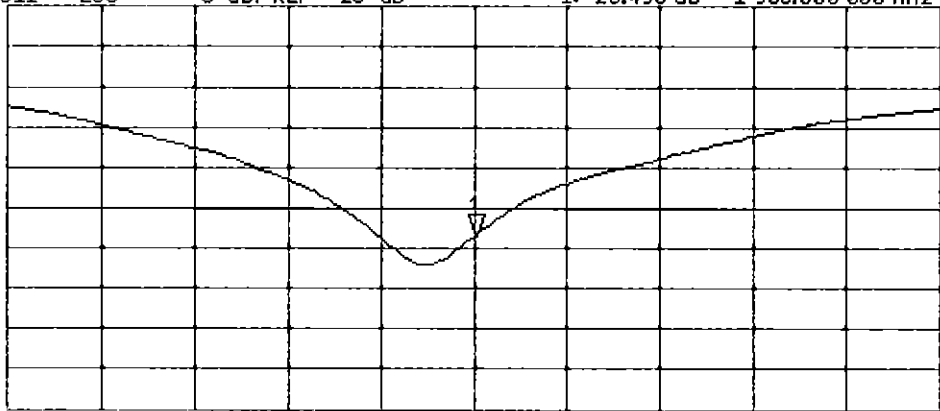

START 1 700.000 000 MHz

STOP 2 1 000.000 000 MHz



Accredited by the Swiss Accreditation Service (SAS)
The Swiss Accreditation Service is one of the signatories to the EA
Multilateral Agreement for the recognition of calibration certificates

Accreditation No.: **SCS 0108**

Client **PC Test**

Certificate No: **D2450V2-882_Feb16**

CALIBRATION CERTIFICATE

Object **D2450V2 - SN: 882**

Calibration procedure(s) **QA CAL-05.v9
Calibration procedure for dipole validation kits above 700 MHz**

Calibration date: **February 18, 2016**

*BN ✓
03/01/2016*

This calibration certificate documents the traceability to national standards, which realize the physical units of measurements (SI).
The measurements and the uncertainties with confidence probability are given on the following pages and are part of the certificate.

All calibrations have been conducted in the closed laboratory facility: environment temperature (22 ± 3)°C and humidity < 70%.

Calibration Equipment used (M&TE critical for calibration)

Primary Standards	ID #	Cal Date (Certificate No.)	Scheduled Calibration
Power meter EPM-442A	GB37480704	07-Oct-15 (No. 217-02222)	Oct-16
Power sensor HP 8481A	US37292783	07-Oct-15 (No. 217-02222)	Oct-16
Power sensor HP 8481A	MY41092317	07-Oct-15 (No. 217-02223)	Oct-16
Reference 20 dB Attenuator	SN: 5058 (20k)	01-Apr-15 (No. 217-02131)	Mar-16
Type-N mismatch combination	SN: 5047.2 / 06327	01-Apr-15 (No. 217-02134)	Mar-16
Reference Probe EX3DV4	SN: 7349	31-Dec-15 (No. EX3-7349_Dec15)	Dec-16
DAE4	SN: 601	30-Dec-15 (No. DAE4-601_Dec15)	Dec-16
Secondary Standards	ID #	Check Date (in house)	Scheduled Check
RF generator R&S SMT-06	100972	15-Jun-15 (in house check Jun-15)	In house check: Jun-18
Network Analyzer HP 8753E	US37390585 S4206	18-Oct-01 (in house check Oct-15)	In house check: Oct-16

Calibrated by: **Claudio Leubler** Name: Claudio Leubler Function: Laboratory Technician

Signature:

Approved by: **Katja Pokovic** Name: Katja Pokovic Function: Technical Manager

Signature:

Issued: February 19, 2016

This calibration certificate shall not be reproduced except in full without written approval of the laboratory.



Accredited by the Swiss Accreditation Service (SAS)
The Swiss Accreditation Service is one of the signatories to the EA
Multilateral Agreement for the recognition of calibration certificates

Accreditation No.: **SCS 0108**

Glossary:

TSL	tissue simulating liquid
ConvF	sensitivity in TSL / NORM x,y,z
N/A	not applicable or not measured

Calibration is Performed According to the Following Standards:

- a) IEEE Std 1528-2013, "IEEE Recommended Practice for Determining the Peak Spatial-Averaged Specific Absorption Rate (SAR) in the Human Head from Wireless Communications Devices: Measurement Techniques", June 2013
- b) IEC 62209-1, "Procedure to measure the Specific Absorption Rate (SAR) for hand-held devices used in close proximity to the ear (frequency range of 300 MHz to 3 GHz)", February 2005
- c) IEC 62209-2, "Procedure to determine the Specific Absorption Rate (SAR) for wireless communication devices used in close proximity to the human body (frequency range of 30 MHz to 6 GHz)", March 2010
- d) KDB 865664, "SAR Measurement Requirements for 100 MHz to 6 GHz"

Additional Documentation:

- e) DASY4/5 System Handbook

Methods Applied and Interpretation of Parameters:

- *Measurement Conditions:* Further details are available from the Validation Report at the end of the certificate. All figures stated in the certificate are valid at the frequency indicated.
- *Antenna Parameters with TSL:* The dipole is mounted with the spacer to position its feed point exactly below the center marking of the flat phantom section, with the arms oriented parallel to the body axis.
- *Feed Point Impedance and Return Loss:* These parameters are measured with the dipole positioned under the liquid filled phantom. The impedance stated is transformed from the measurement at the SMA connector to the feed point. The Return Loss ensures low reflected power. No uncertainty required.
- *Electrical Delay:* One-way delay between the SMA connector and the antenna feed point. No uncertainty required.
- *SAR measured:* SAR measured at the stated antenna input power.
- *SAR normalized:* SAR as measured, normalized to an input power of 1 W at the antenna connector.
- *SAR for nominal TSL parameters:* The measured TSL parameters are used to calculate the nominal SAR result.

The reported uncertainty of measurement is stated as the standard uncertainty of measurement multiplied by the coverage factor $k=2$, which for a normal distribution corresponds to a coverage probability of approximately 95%.

Measurement Conditions

DASY system configuration, as far as not given on page 1.

DASY Version	DASY5	V52.8.8
Extrapolation	Advanced Extrapolation	
Phantom	Modular Flat Phantom	
Distance Dipole Center - TSL	10 mm	with Spacer
Zoom Scan Resolution	dx, dy, dz = 5 mm	
Frequency	2450 MHz ± 1 MHz	

Head TSL parameters

The following parameters and calculations were applied.

	Temperature	Permittivity	Conductivity
Nominal Head TSL parameters	22.0 °C	39.2	1.80 mho/m
Measured Head TSL parameters	(22.0 ± 0.2) °C	38.7 ± 6 %	1.84 mho/m ± 6 %
Head TSL temperature change during test	< 0.5 °C	----	----

SAR result with Head TSL

SAR averaged over 1 cm ³ (1 g) of Head TSL	Condition	
SAR measured	250 mW input power	12.8 W/kg
SAR for nominal Head TSL parameters	normalized to 1W	50.5 W/kg ± 17.0 % (k=2)

SAR averaged over 10 cm ³ (10 g) of Head TSL	condition	
SAR measured	250 mW input power	5.92 W/kg
SAR for nominal Head TSL parameters	normalized to 1W	23.5 W/kg ± 16.5 % (k=2)

Body TSL parameters

The following parameters and calculations were applied.

	Temperature	Permittivity	Conductivity
Nominal Body TSL parameters	22.0 °C	52.7	1.95 mho/m
Measured Body TSL parameters	(22.0 ± 0.2) °C	52.9 ± 6 %	2.00 mho/m ± 6 %
Body TSL temperature change during test	< 0.5 °C	----	----

SAR result with Body TSL

SAR averaged over 1 cm ³ (1 g) of Body TSL	Condition	
SAR measured	250 mW input power	12.5 W/kg
SAR for nominal Body TSL parameters	normalized to 1W	49.4 W/kg ± 17.0 % (k=2)

SAR averaged over 10 cm ³ (10 g) of Body TSL	condition	
SAR measured	250 mW input power	5.81 W/kg
SAR for nominal Body TSL parameters	normalized to 1W	23.1 W/kg ± 16.5 % (k=2)

Appendix (Additional assessments outside the scope of SCS 0108)

Antenna Parameters with Head TSL

Impedance, transformed to feed point	52.5 Ω + 1.0 j Ω
Return Loss	- 31.5 dB

Antenna Parameters with Body TSL

Impedance, transformed to feed point	48.7 Ω + 3.5 j Ω
Return Loss	- 28.6 dB

General Antenna Parameters and Design

Electrical Delay (one direction)	1.157 ns
----------------------------------	----------

After long term use with 100W radiated power, only a slight warming of the dipole near the feedpoint can be measured.

The dipole is made of standard semirigid coaxial cable. The center conductor of the feeding line is directly connected to the second arm of the dipole. The antenna is therefore short-circuited for DC-signals. On some of the dipoles, small end caps are added to the dipole arms in order to improve matching when loaded according to the position as explained in the "Measurement Conditions" paragraph. The SAR data are not affected by this change. The overall dipole length is still according to the Standard.

No excessive force must be applied to the dipole arms, because they might bend or the soldered connections near the feedpoint may be damaged.

Additional EUT Data

Manufactured by	SPEAG
Manufactured on	October 06, 2011

DASY5 Validation Report for Head TSL

Date: 18.02.2016

Test Laboratory: SPEAG, Zurich, Switzerland

DUT: Dipole 2450 MHz; Type: D2450V2; Serial: D2450V2 - SN: 882

Communication System: UID 0 - CW; Frequency: 2450 MHz

Medium parameters used: $f = 2450$ MHz; $\sigma = 1.84$ S/m; $\epsilon_r = 38.7$; $\rho = 1000$ kg/m³

Phantom section: Flat Section

Measurement Standard: DASY5 (IEEE/IEC/ANSI C63.19-2011)

DASY52 Configuration:

- Probe: EX3DV4 - SN7349; ConvF(7.76, 7.76, 7.76); Calibrated: 31.12.2015;
- Sensor-Surface: 1.4mm (Mechanical Surface Detection)
- Electronics: DAE4 Sn601; Calibrated: 30.12.2015
- Phantom: Flat Phantom 5.0 (front); Type: QD000P50AA; Serial: 1001
- DASY52 52.8.8(1258); SEMCAD X 14.6.10(7372)

Dipole Calibration for Head Tissue/ $P_{in}=250$ mW, $d=10$ mm/Zoom Scan (7x7x7)/Cube 0:

Measurement grid: $dx=5$ mm, $dy=5$ mm, $dz=5$ mm

Reference Value = 109.8 V/m; Power Drift = 0.06 dB

Peak SAR (extrapolated) = 25.7 W/kg

SAR(1 g) = 12.8 W/kg; SAR(10 g) = 5.92 W/kg

Maximum value of SAR (measured) = 20.1 W/kg

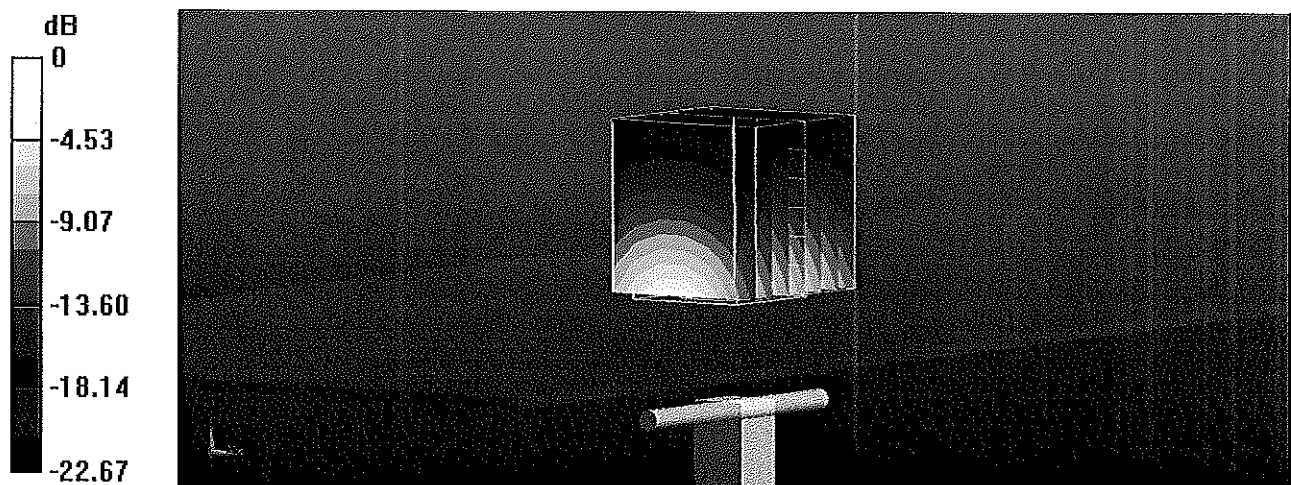

0 dB = 20.1 W/kg = 13.03 dBW/kg

Impedance Measurement Plot for Head TSL

18 Feb 2016 17:46:49

CH1 S11 1 U FS 1: 52.516 Ω 1.0352 Ω 67.245 μ H 2 450.000 000 MHz

*
De1
CA
Avg
16
H1d

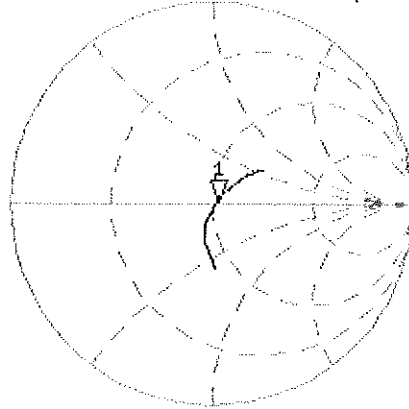

CH2 S11 LOG 5 dB/REF -20 dB 1: -31.516 dB 2 450.000 000 MHz

CA
Avg
16
H1d

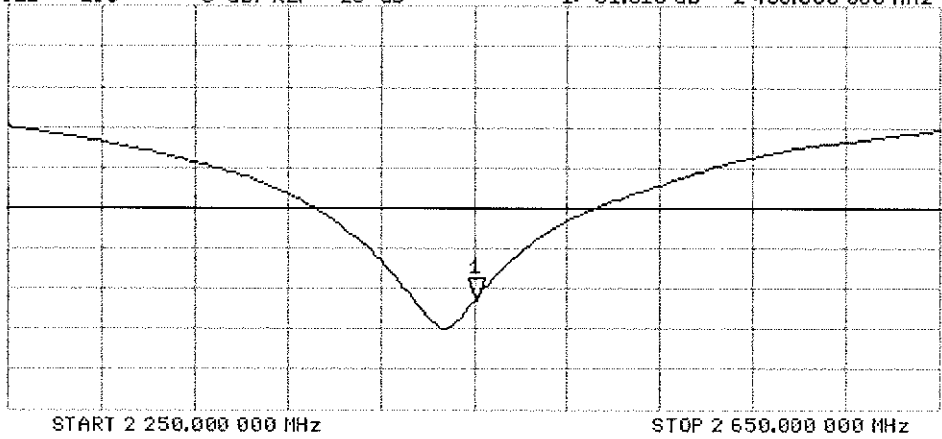

DASY5 Validation Report for Body TSL

Date: 18.02.2016

Test Laboratory: SPEAG, Zurich, Switzerland

DUT: Dipole 2450 MHz; Type: D2450V2; Serial: D2450V2 - SN: 882

Communication System: UID 0 - CW; Frequency: 2450 MHz

Medium parameters used: $f = 2450$ MHz; $\sigma = 2$ S/m; $\epsilon_r = 52.9$; $\rho = 1000$ kg/m³

Phantom section: Flat Section

Measurement Standard: DASY5 (IEEE/IEC/ANSI C63.19-2011)

DASY52 Configuration:

- Probe: EX3DV4 - SN7349; ConvF(7.79, 7.79, 7.79); Calibrated: 31.12.2015;
- Sensor-Surface: 1.4mm (Mechanical Surface Detection)
- Electronics: DAE4 Sn601; Calibrated: 30.12.2015
- Phantom: Flat Phantom 5.0 (back); Type: QD000P50AA; Serial: 1002
- DASY52 52.8.8(1258); SEMCAD X 14.6.10(7372)

Dipole Calibration for Body Tissue/Pin=250 mW, d=10mm/Zoom Scan (7x7x7)/Cube 0:

Measurement grid: dx=5mm, dy=5mm, dz=5mm

Reference Value = 104.8 V/m; Power Drift = 0.01 dB

Peak SAR (extrapolated) = 24.8 W/kg

SAR(1 g) = 12.5 W/kg; SAR(10 g) = 5.81 W/kg

Maximum value of SAR (measured) = 20.0 W/kg

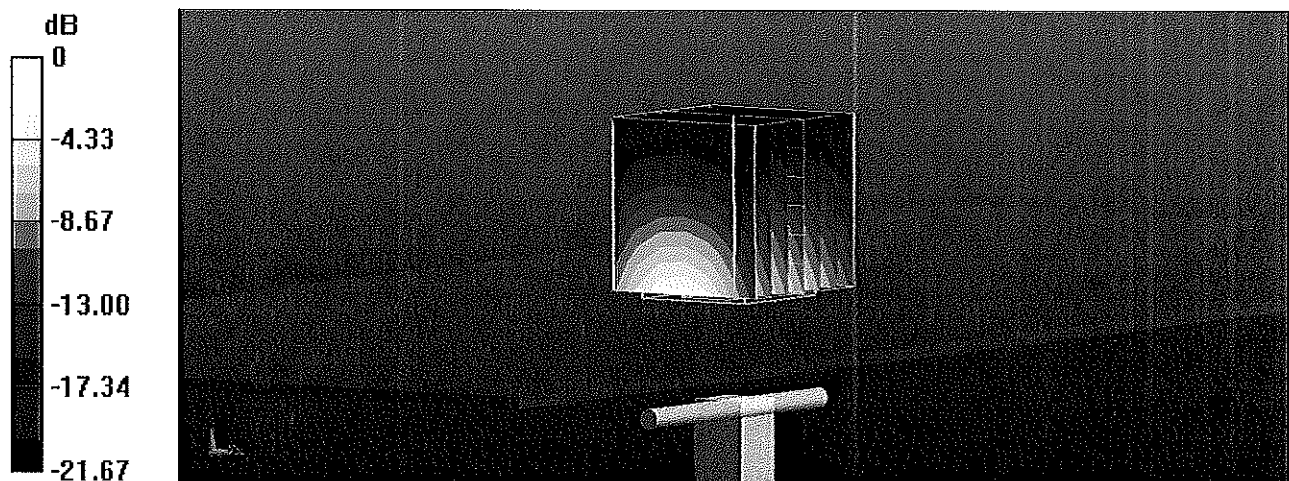

0 dB = 20.0 W/kg = 13.01 dBW/kg

Impedance Measurement Plot for Body TSL

18 Feb 2016 17:47:21

CH1 S11 1 U FS 1: 48.740 Ω 3.4629 Ω 224.95 pH 2 450.000 000 MHz

*
De1

CA

Avg
10

H1d

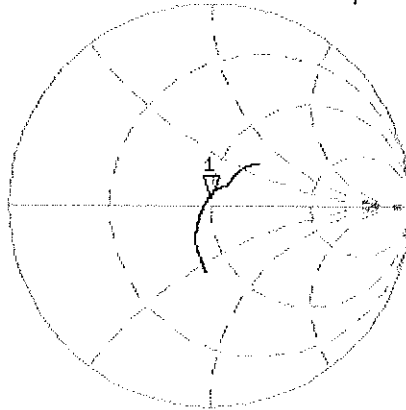

CH2 S11 LOG 5 dB/REF -20 dB 1: -28.562 dB 2 450.000 000 MHz

CA

Avg
10

H1d

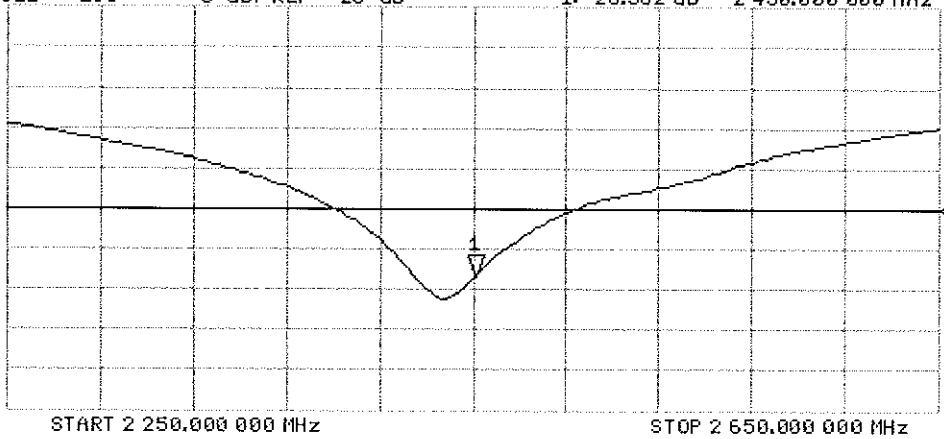



Accredited by the Swiss Accreditation Service (SAS)
The Swiss Accreditation Service is one of the signatories to the EA
Multilateral Agreement for the recognition of calibration certificates

Accreditation No.: **SCS 0108**

Client **PC Test**

Certificate No: **D2600V2-1071_Oct15**

CALIBRATION CERTIFICATE

Object **D2600V2 - SN: 1071**

Calibration procedure(s) **QA CAL-05.v9
Calibration procedure for dipole validation kits above 700 MHz**

Calibration date: **October 21, 2015**

*BN ✓
4/03/15*

This calibration certificate documents the traceability to national standards, which realize the physical units of measurements (SI).
The measurements and the uncertainties with confidence probability are given on the following pages and are part of the certificate.

All calibrations have been conducted in the closed laboratory facility: environment temperature (22 ± 3)°C and humidity < 70%.

Calibration Equipment used (M&TE critical for calibration)

Primary Standards	ID #	Cal Date (Certificate No.)	Scheduled Calibration
Power meter EPM-442A	GB37480704	07-Oct-15 (No. 217-02222)	Oct-16
Power sensor HP 8481A	US37292783	07-Oct-15 (No. 217-02222)	Oct-16
Power sensor HP 8481A	MY41092317	07-Oct-15 (No. 217-02223)	Oct-16
Reference 20 dB Attenuator	SN: 5058 (20k)	01-Apr-15 (No. 217-02131)	Mar-16
Type-N mismatch combination	SN: 5047.2 / 06327	01-Apr-15 (No. 217-02134)	Mar-16
Reference Probe EX3DV4	SN: 7349	30-Dec-14 (No. EX3-7349_Dec14)	Dec-15
DAE4	SN: 601	17-Aug-15 (No. DAE4-601_Aug15)	Aug-16
Secondary Standards	ID #	Check Date (in house)	Scheduled Check
RF generator R&S SMT-06	100972	15-Jun-15 (in house check Jun-15)	In house check: Jun-18
Network Analyzer HP 8753E	US37390585 54206	18-Oct-01 (in house check Oct-15)	In house check: Oct-16

Calibrated by: **Leif Klystner** Name: **Leif Klystner** Function: **Laboratory Technician**

Approved by: **Katja Pokovic** Name: **Katja Pokovic** Function: **Technical Manager**

Signature
Leif Klystner

Katja Pokovic

Issued: October 22, 2015

This calibration certificate shall not be reproduced except in full without written approval of the laboratory.



Accredited by the Swiss Accreditation Service (SAS)

The Swiss Accreditation Service is one of the signatories to the EA Multilateral Agreement for the recognition of calibration certificates

Accreditation No.: **SCS 0108**

Glossary:

TSL	tissue simulating liquid
ConvF	sensitivity in TSL / NORM x,y,z
N/A	not applicable or not measured

Calibration is Performed According to the Following Standards:

- IEEE Std 1528-2013, "IEEE Recommended Practice for Determining the Peak Spatial-Averaged Specific Absorption Rate (SAR) in the Human Head from Wireless Communications Devices: Measurement Techniques", June 2013
- IEC 62209-1, "Procedure to measure the Specific Absorption Rate (SAR) for hand-held devices used in close proximity to the ear (frequency range of 300 MHz to 3 GHz)", February 2005
- IEC 62209-2, "Procedure to determine the Specific Absorption Rate (SAR) for wireless communication devices used in close proximity to the human body (frequency range of 30 MHz to 6 GHz)", March 2010
- KDB 865664, "SAR Measurement Requirements for 100 MHz to 6 GHz"

Additional Documentation:

- DASY4/5 System Handbook

Methods Applied and Interpretation of Parameters:

- Measurement Conditions:** Further details are available from the Validation Report at the end of the certificate. All figures stated in the certificate are valid at the frequency indicated.
- Antenna Parameters with TSL:** The dipole is mounted with the spacer to position its feed point exactly below the center marking of the flat phantom section, with the arms oriented parallel to the body axis.
- Feed Point Impedance and Return Loss:** These parameters are measured with the dipole positioned under the liquid filled phantom. The impedance stated is transformed from the measurement at the SMA connector to the feed point. The Return Loss ensures low reflected power. No uncertainty required.
- Electrical Delay:** One-way delay between the SMA connector and the antenna feed point. No uncertainty required.
- SAR measured:** SAR measured at the stated antenna input power.
- SAR normalized:** SAR as measured, normalized to an input power of 1 W at the antenna connector.
- SAR for nominal TSL parameters:** The measured TSL parameters are used to calculate the nominal SAR result.

The reported uncertainty of measurement is stated as the standard uncertainty of measurement multiplied by the coverage factor $k=2$, which for a normal distribution corresponds to a coverage probability of approximately 95%.

Measurement Conditions

DASY system configuration, as far as not given on page 1.

DASY Version	DASY5	V52.8.8
Extrapolation	Advanced Extrapolation	
Phantom	Modular Flat Phantom	
Distance Dipole Center - TSL	10 mm	with Spacer
Zoom Scan Resolution	dx, dy, dz = 5 mm	
Frequency	2600 MHz \pm 1 MHz	

Head TSL parameters

The following parameters and calculations were applied.

	Temperature	Permittivity	Conductivity
Nominal Head TSL parameters	22.0 °C	39.0	1.98 mho/m
Measured Head TSL parameters	(22.0 \pm 0.2) °C	37.4 \pm 6 %	2.02 mho/m \pm 6 %
Head TSL temperature change during test	< 0.5 °C	----	----

SAR result with Head TSL

SAR averaged over 1 cm ³ (1 g) of Head TSL	Condition	
SAR measured	250 mW input power	14.3 W/kg
SAR for nominal Head TSL parameters	normalized to 1W	55.9 W/kg \pm 17.0 % (k=2)

SAR averaged over 10 cm ³ (10 g) of Head TSL	condition	
SAR measured	250 mW input power	6.33 W/kg
SAR for nominal Head TSL parameters	normalized to 1W	25.0 W/kg \pm 16.5 % (k=2)

Body TSL parameters

The following parameters and calculations were applied.

	Temperature	Permittivity	Conductivity
Nominal Body TSL parameters	22.0 °C	52.5	2.16 mho/m
Measured Body TSL parameters	(22.0 \pm 0.2) °C	52.4 \pm 6 %	2.16 mho/m \pm 6 %
Body TSL temperature change during test	< 0.5 °C	----	----

SAR result with Body TSL

SAR averaged over 1 cm ³ (1 g) of Body TSL	Condition	
SAR measured	250 mW input power	13.8 W/kg
SAR for nominal Body TSL parameters	normalized to 1W	54.9 W/kg \pm 17.0 % (k=2)

SAR averaged over 10 cm ³ (10 g) of Body TSL	condition	
SAR measured	250 mW input power	6.14 W/kg
SAR for nominal Body TSL parameters	normalized to 1W	24.5 W/kg \pm 16.5 % (k=2)

Appendix (Additional assessments outside the scope of SCS 0108)

Antenna Parameters with Head TSL

Impedance, transformed to feed point	49.4 Ω - 5.4 j Ω
Return Loss	- 25.2 dB

Antenna Parameters with Body TSL

Impedance, transformed to feed point	45.7 Ω - 4.6 j Ω
Return Loss	- 23.7 dB

General Antenna Parameters and Design

Electrical Delay (one direction)	1.153 ns
----------------------------------	----------

After long term use with 100W radiated power, only a slight warming of the dipole near the feedpoint can be measured.

The dipole is made of standard semirigid coaxial cable. The center conductor of the feeding line is directly connected to the second arm of the dipole. The antenna is therefore short-circuited for DC-signals. On some of the dipoles, small end caps are added to the dipole arms in order to improve matching when loaded according to the position as explained in the "Measurement Conditions" paragraph. The SAR data are not affected by this change. The overall dipole length is still according to the Standard.

No excessive force must be applied to the dipole arms, because they might bend or the soldered connections near the feedpoint may be damaged.

Additional EUT Data

Manufactured by	SPEAG
Manufactured on	July 17, 2013

DASY5 Validation Report for Head TSL

Date: 21.10.2015

Test Laboratory: SPEAG, Zurich, Switzerland

DUT: Dipole 2600 MHz; Type: D2600V2; Serial: D2600V2 - SN: 1071

Communication System: UID 0 - CW; Frequency: 2600 MHz

Medium parameters used: $f = 2600$ MHz; $\sigma = 2.02$ S/m; $\epsilon_r = 37.4$; $\rho = 1000$ kg/m³

Phantom section: Flat Section

Measurement Standard: DASY5 (IEEE/IEC/ANSI C63.19-2011)

DASY52 Configuration:

- Probe: EX3DV4 - SN7349; ConvF(7.4, 7.4, 7.4); Calibrated: 30.12.2014;
- Sensor-Surface: 1.4mm (Mechanical Surface Detection)
- Electronics: DAE4 Sn601; Calibrated: 17.08.2015
- Phantom: Flat Phantom 5.0 (front); Type: QD000P50AA; Serial: 1001
- DASY52 52.8.8(1222); SEMCAD X 14.6.10(7331)

Dipole Calibration for Head Tissue/ $P_{in}=250$ mW, $d=10$ mm/Zoom Scan (7x7x7)/Cube 0:

Measurement grid: $dx=5$ mm, $dy=5$ mm, $dz=5$ mm

Reference Value = 115.2 V/m; Power Drift = 0.03 dB

Peak SAR (extrapolated) = 30.8 W/kg

SAR(1 g) = 14.3 W/kg; SAR(10 g) = 6.33 W/kg

Maximum value of SAR (measured) = 24.2 W/kg

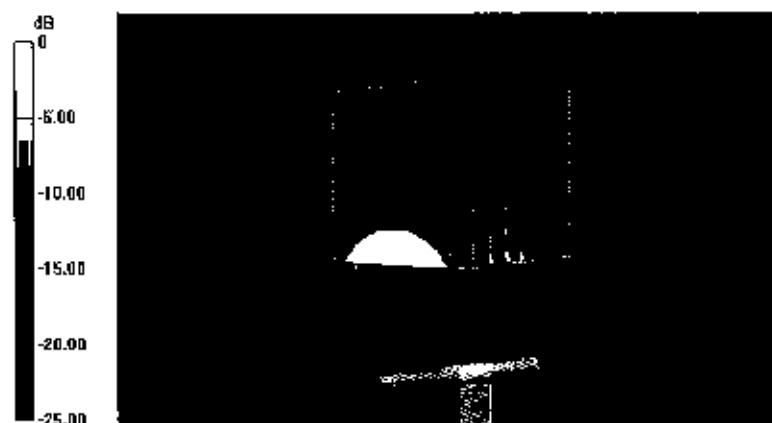

0 dB = 24.2 W/kg = 13.84 dBW/kg

Impedance Measurement Plot for Head TSL

21 Oct 2015 09:53:21

CH1 S11 1 U F8 1: 49.434 Ω -5.4141 Ω 11.306 pF 2 600.000 000 MHz

Del
CA
Avg
16
Hid

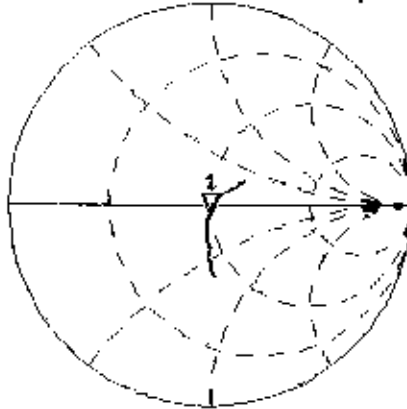

CH2 S11 LOG 5 dB/REF -20 dB 1: -25.246 dB 2 600.000 000 MHz

Del
CA
Avg
16
Hid

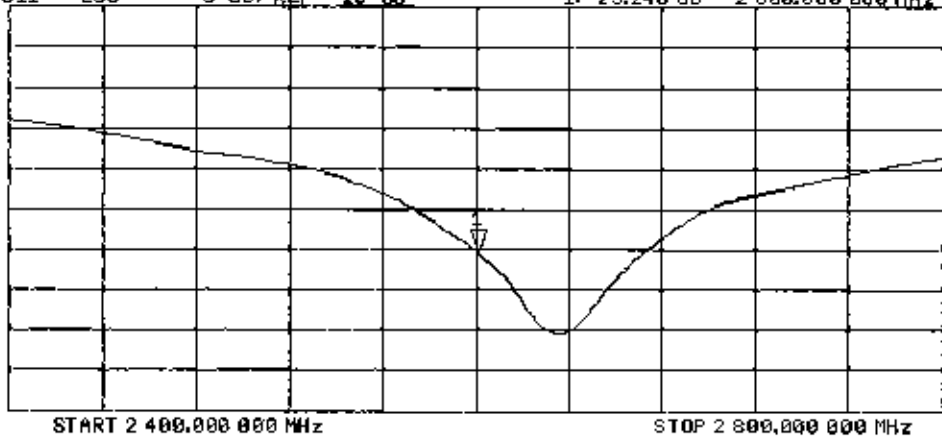

DASY5 Validation Report for Body TSL

Date: 21.10.2015

Test Laboratory: SPEAG, Zurich, Switzerland

DUT: Dipole 2600 MHz; Type: D2600V2; Serial: D2600V2 - SN: 1071

Communication System: UID 0 - CW; Frequency: 2600 MHz

Medium parameters used: $f = 2600$ MHz; $\sigma = 2.18$ S/m; $\epsilon_r = 52.4$; $\rho = 1000$ kg/m³

Phantom section: Flat Section

Measurement Standard: DASY5 (IEEE/IEC/ANSI C63.19-2011)

DASY52 Configuration:

- Probe: EX3DV4 - SN7349; ConvF(7.52, 7.52, 7.52); Calibrated: 30.12.2014;
- Sensor-Surface: 1.4mm (Mechanical Surface Detection)
- Electronics: DAE4 Sn601; Calibrated: 17.08.2015
- Phantom: Flat Phantom 5.0 (back); Type: QD000P50AA; Serial: 1002
- DASY52 52.8.8(1222); SEMCAD X 14.6.10(7331)

Dipole Calibration for Body Tissue/Pin=250 mW, d=10mm/Zoom Scan (7x7x7)/Cube 0:

Measurement grid: dx=5mm, dy=5mm, dz=5mm

Reference Value = 108.6 V/m; Power Drift = -0.02 dB

Peak SAR (extrapolated) = 28.8 W/kg

SAR(1 g) = 13.8 W/kg; SAR(10 g) = 6.14 W/kg

Maximum value of SAR (measured) = 23.3 W/kg

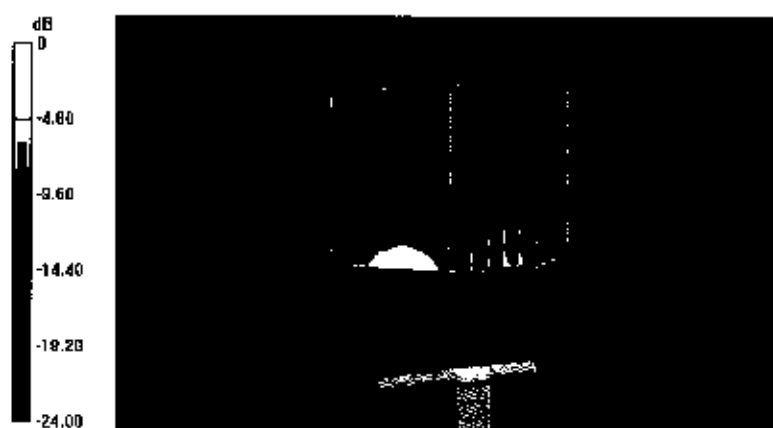

0 dB = 23.3 W/kg = 13.67 dBW/kg

Impedance Measurement Plot for Body TSL

21 Oct 2015 09:52:46

CH1 S11 1 0 FS

λ : 45.715 n Γ : -4.6074 n 13.286 pF

2 500.000 000 MHz

De1
CA
Avg
16
H1d

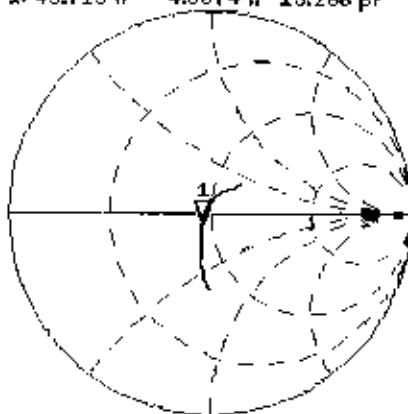

CH2 S11 LOG

5 dB/REF -20 dB

1:-23.655 dB

2 500.000 000 MHz

De1
CA
Avg
16
H1d

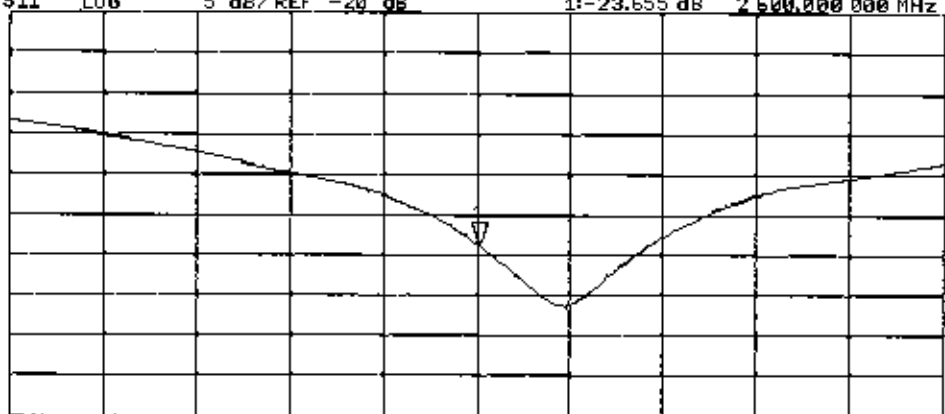

START 2 400.000 000 MHz

STOP 2 800.000 000 MHz