



**HAC RF EMISSIONS TEST REPORT  
(CLASS II PERMISSIVE CHANGE)**

**FCC 47 CFR § 20.19  
ANSI C63.19-2011**

*For*  
**CDMA/LTE PHONE WITH BT & DTS WLAN b/g/n**

**FCC ID: ZNFL62VL  
Model Name: LGL62VL, L62VL, LG-L62VL**

**Report Number: 16I22653-S3V2  
Issue Date: 2/8/2016**

*Prepared for*  
**LG ELECTRONICS MOBILECOMM USA, INC.  
1000 SYLVAN AVENUE  
ENGLEWOOD CLIFFS, NEW JERSEY 07632, USAy**

*Prepared by*  
**UL VERIFICATION SERVICES INC.  
47173 BENICIA STREET  
FREMONT, CA 94538, U.S.A.  
TEL: (510) 771-1000  
FAX: (510) 661-0888**



NVLAP LAB CODE 200065-0

**Revision History**

Rev.	Date	Revisions	Revised By
V1	1/26/2016	Initial Issue	--
V2	2/8/2016	Section 1: Updated FCC ID	Coltyce Sanders

## Table of Contents



<b>1. Attestation of Test Results</b> .....	<b>4</b>
<b>2. Test Methodology</b> .....	<b>5</b>
<b>3. Facilities and Accreditation</b> .....	<b>5</b>
<b>4. Calibration and Uncertainty</b> .....	<b>5</b>
4.1. <i>Measuring Instrument Calibration</i> .....	5
4.2. <i>Measurement Uncertainty</i> .....	6
<b>5. System Specifications</b> .....	<b>7</b>
<b>6. System Validation</b> .....	<b>8</b>
6.1. <i>System Validation Results</i> .....	9
<b>7. Average Antenna Input Power &amp; Evaluation for Low-power Exemption</b> .....	<b>9</b>
<b>8. Device Under Test</b> .....	<b>10</b>
8.1. <i>Air Interfaces and Operating Mode</i> .....	10
<b>9. Modulation Interference Factor (MIF)</b> .....	<b>11</b>
<b>10. HAC RF Emissions Test Procedure</b> .....	<b>12</b>
<b>11. RF Emissions Measurement Criteria</b> .....	<b>15</b>
<b>12. HAC (RF Emissions) Test Results</b> .....	<b>15</b>
12.1. <i>Worst Case RF Emission Test Plot</i> .....	16
<b>Appendixes</b> .....	<b>17</b>
16I22653-S3V1 HAC_RF_App A Setup Photo .....	17
16I22653-S3V1 HAC_RF_App B System Validation Plots.....	17
16I22653-S3V1 HAC_RF_App C RF Emissions Test Plots .....	17
16I22653-S3V1 HAC_RF_App D MIF Attestation Letter.....	17
16I22653-S3V1 HAC_RF_App E Probe Cal. Certificate .....	17
16I22653-S3V1 HAC_RF_App F Dipole Cal. Certificates .....	17
16I22653-S3V1 HAC_RF_App G UID Specification .....	17

## 1. Attestation of Test Results

Applicant Name	LG ELECTRONICS MOBILECOMM USA, INC.
FCC ID	ZNFL62VL
Model Name	LGL62VL, L62VL, LG-L62VL
Applicable Standards	FCC 47 CFR § 20.19 ANSI C63.19-2011 KDB 285076 D01 HAC Guidance TCB workshop updates
HAC Rating	M4
Date Tested	1/13/2016
Test Results	Pass

UL Verification Services Inc. tested the above equipment in accordance with the requirements set forth in the above standards. All indications of Pass/Fail in this report are opinions expressed by UL Verification Services Inc. based on interpretations and/or observations of test results. Measurement Uncertainties were not taken into account and are published for informational purposes only. The test results show that the equipment tested is capable of demonstrating compliance with the requirements as documented in this report.

**Note:** The results documented in this report apply only to the tested sample, under the conditions and modes of operation as described herein. This document may not be altered or revised in any way unless done so by UL Verification Services Inc. and all revisions are duly noted in the revisions section. Any alteration of this document not carried out by UL Verification Services Inc. will constitute fraud and shall nullify the document. This report must not be used by the client to claim product certification, approval, or endorsement by NVLAP, NIST, any agency of the Federal Government, or any agency of any government (NIST Handbook 150, Annex A). This report is written to support regulatory compliance of the applicable standards stated above.

Approved & Released By: 	Prepared By: 
Devin Chang Senior Engineer UL Verification Services Inc.	Krishelle Aurelio Laboratory Technician UL Verification Services Inc.

## 2. Test Methodology

The tests documented in this report were performed in accordance with ANSI C63.19-2011 Methods of Measurement of Compatibility between Wireless Communications Devices and Hearing Aids, FCC published KDB 285076 D01 HAC Guidance v04 and TCB workshop updates.

## 3. Facilities and Accreditation

The test sites and measurement facilities used to collect data are located at

47173 Benicia Street	47266 Benicia Street
SAR Lab C	SAR Lab 2

UL Verification Services Inc. is accredited by NVLAP, Laboratory Code 200065-0.

## 4. Calibration and Uncertainty

### 4.1. Measuring Instrument Calibration

The measuring equipment utilized to perform the tests documented in this report has been calibrated in accordance with the manufacturer's recommendations, and is traceable to recognized national standards.

Name of Equipment	Manufacturer	Type/Model	Serial No.	Cal. Due Date
Synthesized Signal Generator	HP	8665B	3744A01084	5/8/2016
Power Meter	Agilent	N1912A	MY50001018	10/19/2016
Power Sensor	Agilent	E9323A	MY53070007	3/2/2016
Power Sensor	Agilent	E9323A	MY53070005	4/29/2016
Amplifier	MITEQ	AMF-4D-00400600-50-30P	1795093	N/A
Directional coupler	Werlatone	C8060-102	2149	N/A
DC Power Supply	AMETEK	XT 15-4	1319A02778	N/A
Robot Remote Control	Stäubli	CS8C	N/A	N/A
DASY5 Measurement Server	SPEAG	SEUMS001BA	1041	N/A
Probe Alignment Unit	SPEAG	LB (V2)	261	N/A
Data Acquisition Electronics	SPEAG	DAE3	427	1/14/2016
E-Field Probe*	SPEAG	ER3DV6	2509	5/14/2016
Calibration Dipole	SPEAG	CD835V3	1175	5/18/2016
Calibration Dipole	SPEAG	CD1880V3	1159	5/18/2016
Radio Communication Tester	R & S	CMU 500	125326	1/19/2016

#### Note(s):

\*: According to SPEAG's Technical Report, "MIF Verification", Doc # TR-FB-12.09.04-1, issued date: 9/4/2012. E-field probes are calibrated with specified uncertainty according to ISO 17025 as described in their calibration certificate. The MIF according to the definition in ANSI C63.19 is specific for a modulation and can therefore be used as a constant value if the probe has been PMR calibrated.

## 4.2. Measurement Uncertainty

HAC Uncertainty Budget According to ANSI C63.19

Error Description	Uncertainty value (±%)	Probe Dist.	Div.	(Ci) E	(Ci) H	Std. Unc.(±%)	
						E	H
<b>Measurement System</b>							
Probe Calibration	5.1	N	1	1	1	5.1	5.10
Axial Isotropy	4.7	R	1.732	1	1	2.7	2.71
Sensor Displacement	16.5	R	1.732	1	0.145	9.5	1.38
Boundary Effects	2.4	R	1.732	1	1	1.4	1.39
Phantom Boundary Effects	7.2	R	1.732	1	0	4.1	0.00
Linearity	4.7	R	1.732	1	1	2.7	2.71
Scaling to PMR Calibration	10.0	R	1.732	1	1	5.8	5.77
System Detection Limit	1.0	R	1.732	1	1	0.6	0.58
Readout Electronics	0.3	N	1	1	1	0.3	0.30
Response Time	0.8	R	1.732	1	1	0.5	0.46
Integration Time	2.6	R	1.732	1	1	1.5	1.50
RF Ambient Conditions	3.0	R	1.732	1	1	1.7	1.73
RF Reflections	12.0	R	1.732	1	1	6.9	6.93
Probe Positioner	1.2	R	1.732	1	0.67	0.7	0.46
Probe Positioning	4.7	R	1.732	1	0.67	2.7	1.82
Extrapolation and Interpolation	1.0	R	1.732	1	1	0.6	0.58
<b>Test sample Related</b>							
Test Positioning Vertical	4.7	R	1.732	1	0.67	2.7	1.82
Test Positioning Lateral	1.0	R	1.732	1	1	0.6	0.58
Device Holder and Phantom	2.4	R	1.732	1	1	1.4	1.39
Power Drift	5.0	R	1.732	1	1	2.9	2.89
<b>Phantom and Setup Related</b>							
Phantom Thickness	2.4	R	1.732	1	0.67	1.4	0.93
Combined Std. Uncertainty						16.3	12.3
<b>Expanded Std. Uncertainty on Power</b>						<b>32.6</b>	<b>24.6</b>
<b>Expanded Std. Uncertainty on Field</b>						<b>16.3</b>	<b>12.3</b>
Notes for table 1. N - Nomal 2. R - Rectangular 3. Div. - Divisor used to obtain standard uncertainty 4. Ci - is te sensitivity coefficient							

## 5. System Specifications

E-field measurements are performed using the DASY5 automated dosimetric assessment system. The DASY5 is made by Schmid & Partner Engineering AG (SPEAG) in Zurich, Switzerland.

The DASY5 HAC Extension consists of the following parts:

### Test Arch Phantom

The specially designed Test Arch allows high precision positioning of both the device and any of the validation dipoles.

### ER3DV6 Isotropic E-Field Probe

Construction:	One dipole parallel, two dipoles normal to probe axis Built-in shielding against static charges PEEK enclosure material (resistant to organic solvents, e.g., glycoether)
Calibration:	In air from 100 MHz to 3.0 GHz (absolute accuracy $\pm 6.0\%$ , $k=2$ )
Frequency:	100 MHz to > 6 GHz; Linearity: $\pm 0.2$ dB (100 MHz to 3 GHz)
Directivity:	$\pm 0.2$ dB in air (rotation around probe axis) $\pm 0.4$ dB in air (rotation normal to probe axis)
Dynamic Range:	2 V/m to > 1000 V/m; Linearity: $\pm 0.2$ dB
Dimensions:	Overall length: 330 mm (Tip: 16 mm) Tip diameter: 8 mm (Body: 12 mm) Distance from probe tip to dipole centers: 2.5 mm The closest part of the sensor element is 1.1 mm closer to the tip
Application:	General near-field measurements up to 6 GHz Field component measurements

## 6. System Validation

The test setup was validated when first configured and verified periodically thereafter to ensure proper function. The procedure provided in this section is a validation procedure using dipole antennas for which the field levels were computed by numeric modeling.

### Procedure

Place a dipole antenna meeting the requirements given in ANSI C63.19-2011 in the normally occupied by the WD.

The dipole antenna serves as a known source for an electrical and magnetic output. Position the E-field probe so that the following occurs:

- The probes and their cables are parallel to the coaxial feed of the dipole antenna
- The probe cables and the coaxial feed of the dipole antenna approach the measurement area from opposite directions
- The center point of the probe element(s) is 15 mm from the closest surface of the dipole elements.

Scan the length of the dipole with the E-field probe and record the two maximum values found near the dipole ends. Average the two readings and compare the reading to the expected value in the calibration certificate or the expected value in this standard.

**Setup diagram**

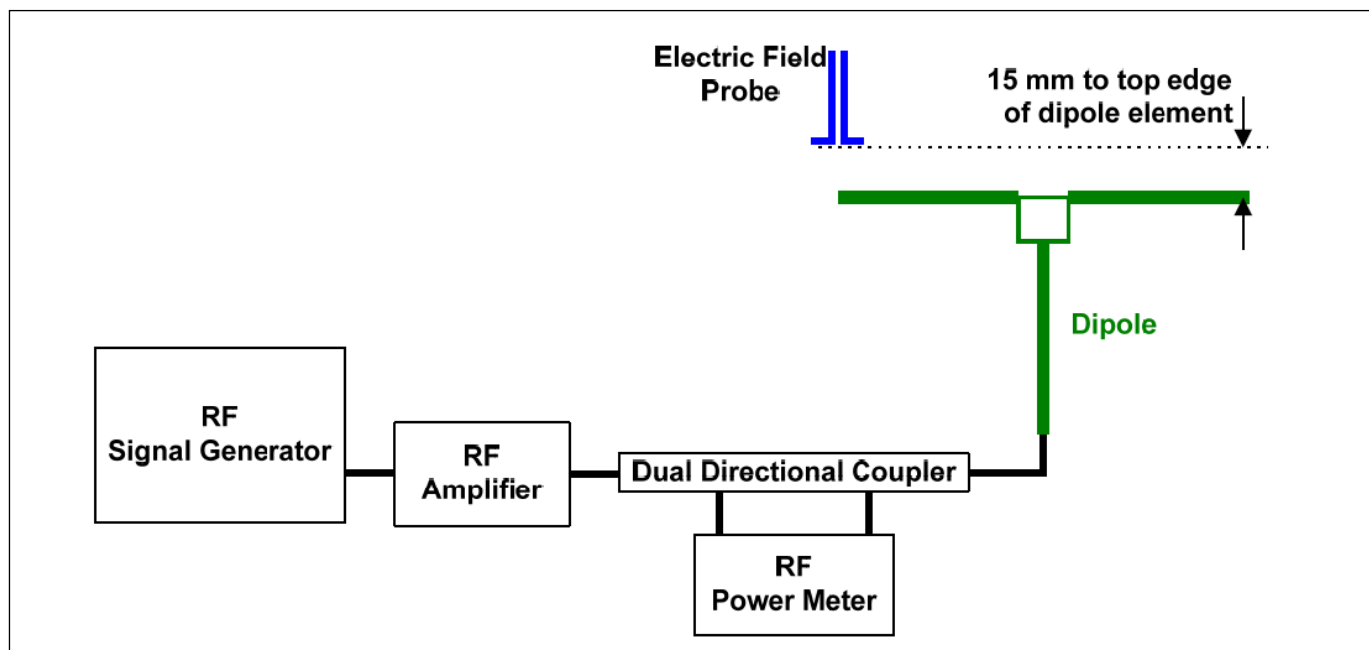



## 6.1. System Validation Results

Calibration Dipole	f (MHz)	Input Power (mW)	Max. measured from		Average max. above arm (V/m)	E-field Target Values (V/m) (From SPEAG)	Deviation <sup>1)</sup> (%)
			above high end (V/m)	above low end (V/m)			
CD835V3 SN 1175	835	100	109.90	106.10	108.00	106.3	1.60
CD1880V3 SN 1159	1880	100	87.69	91.18	89.44	89.50	-0.07

### Notes:

- 1) Delta (Deviation) % = 100 \* (Measured value minus Target value) divided by the Target value. Deltas within  $\pm 25\%$  are acceptable, of which 12% is deviation and 13% is measurement uncertainty.
- 2) The maximum E-field or were evaluated and compared to the target values provided by SPEAG in the calibration certificate of specific dipoles.
- 3) Please refer to the appendix for detailed measurement data and plots.

## 7. Average Antenna Input Power & Evaluation for Low-power Exemption

An RF air interface technology of a device is exempt from testing when its average antenna input power plus its **MIF is  $\leq 17$  dBm** for any of its operating modes. If a device supports multiple RF air interfaces, each RF air interface shall be evaluated individually.

Air-Interface	Average Antenna Input Power (dBm) <sup>1</sup>	Worst Case MIF (dB)	Input Power plus its MIF (dBm)	HAC Tested
CDMA BC0	24.4	3.26	27.66	Yes
CDMA BC1	24.7	3.26	27.96	Yes
LTE Band 2	24.2	-9.76	14.44	No
LTE Band 4	24.4	-9.76	14.64	No
LTE Band 13	24.2	-9.76	14.44	No
802.11b	16.0	-2.02	13.98	No
802.11g	13.0	0.12	13.12	No

### Note(s):

1. Max tune-up limit

## 8. Device Under Test

Normal operation	Held to head		
Back Cover	<input checked="" type="checkbox"/> Normal Battery Cover		
Test sample information	<b>S/N</b>	<b>IMEI</b>	<b>Notes</b>
	601KPVH000743	354792-07-000743-4	HAC unit
	601KPPB000744	354792-07-000744-2	HAC unit

### 8.1. Air Interfaces and Operating Mode

Air-Interface	Bands (MHz)	Type Transport	HAC Tested	Simultaneous but not Tested	Voice over digital Transport OTT Capability	Power Reduction
CDMA	800	VO	Yes	BT	NA	NA
	1900					
	EVDO	DT	No	BT	NA	NA
LTE - FDD	700	VD	No <sup>1</sup>	BT	No	NA
	1700					
	1900					
Wi-Fi	2450	VD	No <sup>1</sup>	NA	NA	NA
BT	2450	DT	NA	WWAN	NA	NA
Type Transport VO=CMRS Voice Service DT – Digital Transport VD=CMRS IP Voice Service and Digital Transport				Note: 1. Evaluated for MIF and low power exemption.		

## 9. Modulation Interference Factor (MIF)

The HAC Standard ANSI C63.19-2011 defines a new scaling using the Modulation Interference Factor (MIF) which replaces the need for the Articulation Weighting Factor (AWF) during the evaluation and is applicable to any modulation scheme.

The Modulation Interference factor (MIF, in dB) is added to the measured average E-field (in dBV/m) and converts it to the RF Audio Interference level (in dBV/m). This level considers the audible amplitude modulation components in the RF E-field. CW fields without amplitude modulation are assumed to not interfere with the hearing aid electronics. Modulations without time slots and low fluctuations at low frequencies have low MIF values, TDMA modulations with narrow transmission and repetition rates of few 100 Hz have high MIF values and give similar classifications as ANSI C63-2007.

### Definitions

ER3D, E-field probes have a bandwidth <10 kHz and can therefore not evaluate the RF envelope in the full audio band. DASY52 is therefore using the "indirect" measurement method according to ANSI C63.19-2011 which is the primary method. These near field probes read the averaged E-field measurement. Especially for the new high peak-to-average (PAR) signal types, the probes shall be linearized by probe modulation response (PMR) calibration in order to not overestimate the field reading.

The evaluation method of the MIF is defined in ANSI C63.19-2011 section D.7. An RMS demodulated RF signal is fed to a spectral filter (similar to an A weighting filter) and forwarded to a temporal filter acting as a quasi-peak detector. The averaged output of these filtering is called to a 1 kHz 80% AM signal as reference. MIF measurement requires additional instrumentation and is not well suited for evaluation by the end user with reasonable uncertainty. It may alternatively be determined through analysis and simulation, because it is constraint and characteristic for a communication signal. DASY52 uses well defined signals for PMR calibration. The MIF of these signals has been determined by simulation and is automatically applied.

MIF values were not tested by a probe or as specified in the standards but are based on analysis provided by SPEAG for all the air interfaces (GSM, WCDMA, CDMA, LTE). The data included in this report are for the worst case operating modes. The UIDs used are listed below:

UID	Communication System Name	MIF (dB)
10295-AAB	CDMA2000 (1xRTT, RC1, SO3, 1/8 <sup>th</sup> Rate 25 fr.)	3.26
10170-CAB	LTE-FDD (SC-FDMA, 1 RB, 20 MHz, 16QAM)	-9.76
10176-CAB	LTE-FDD (SC-FDMA, 1 RB, 10 MHz, 16QAM)	-9.76
10061-CAA	IEEE 802.11b WiFi 2.4 GHz (DSSS, 11 Mbps)	-2.02
10077-CAA	IEEE 802.11g WiFi 2.4 GHz (DSSS/OFDM, 54 Mbps)	0.12

A PMR calibrated probe is linearized for the selected waveform over the full dynamic range within the uncertainty specified in its calibration certificate. ER3D, EF3D and EU2D E-field probes have a bandwidth <10 kHz and can therefore not evaluate the RF envelope in the full audio band. DASY52 is therefore using the "indirect" measurement method according to ANSI C63.19-2011 which is the primary method. These near field probes read the averaged E-field measurement. Especially for the new high peak-to-average (PAR) signal types, the probes shall be linearized by PMR calibration in order to not overestimate the field reading.

The MIF measurement uncertainty is estimated as follows, for modulation frequencies from slotted waveforms with fundamental frequency and at least 2 harmonics within 10 kHz:

- 0.2 dB for MIF -7 to +5 dB,
- 0.5 dB for MIF -13 to +11 dB
- 1 dB for MIF > -20 dB

## 10. HAC RF Emissions Test Procedure

The following are step-by-step test procedures.

- a) Confirm proper operation of the field probe, probe measurement system and other instrumentation and the positioning system.
- b) Position the WD in its intended test position.
- c) Set the WD to transmit a fixed and repeatable combination of signal power and modulation characteristic that is representative of the worst case (highest interference potential) encountered in normal use. Transiently occurring start-up, changeover, or termination conditions, or other operations likely to occur less than 1% of the time during normal operation, may be excluded from consideration.
- d) The center sub-grid shall be centered on the T-Coil mode perpendicular measurement point or the acoustic output, as appropriate. Locate the field probe at the initial test position in the 50 mm by 50 mm grid, which is contained in the measurement plane, refer to illustrated in Figure 1. If the field alignment method is used, align the probe for maximum field reception.
- e) Record the reading at the output of the measurement system
- f) Scan the entire 50 mm by 50 mm region in equally spaced increments and record the reading at each measurement point. The distance between measurement points shall be sufficient to assure the identification of the maximum reading.
- g) Identify the five contiguous sub-grids around the center sub-grid whose maximum reading is the lowest of all available choices. This eliminates the three sub-grids with the maximum readings. Thus, the six areas to be used to determine the WD's highest emissions are identified.
- h) Identify the maximum reading within the non-excluded sub-grids identified in step g).
- i) Convert the highest field reading within identified in step h) to RF audio interference level, in V/m, by taking the square root of the reading and then dividing it by the measurement system transfer function, established in 5.5.1.1 Convert this result to dB(V/m) by taking the base-10 logarithm and multiplying by 20.

Indirect measurement method

Replacing step i), the RF audio interference level in dB (V/m) is obtained by adding the MIF (in dB) to the maximum steady-state rms field-strength reading, in dB (V/m), from step h). Use this result to determine the category rating

- j) Compare this RF audio interference level with the categories in Clause 8 (ANSI C63.19-2011) and record the resulting WD category rating
- k) For the T-Coil mode M-rating assessment, determine whether the chosen perpendicular measurement point is contained in an included sub-grid of the first scan. If so, then a second scan is not necessary. The first scan and resultant category rating may be used for the T-Coil mode M rating.

Otherwise, repeat step a) through step i), with the grid shifted so that it is centered on the perpendicular measurement point. Record the WD category rating.



Figure 1 - WD reference and plane for RF emission measurements

**Test flowchart Per ANSI-PC63.19 2011**

**Test Instructions**

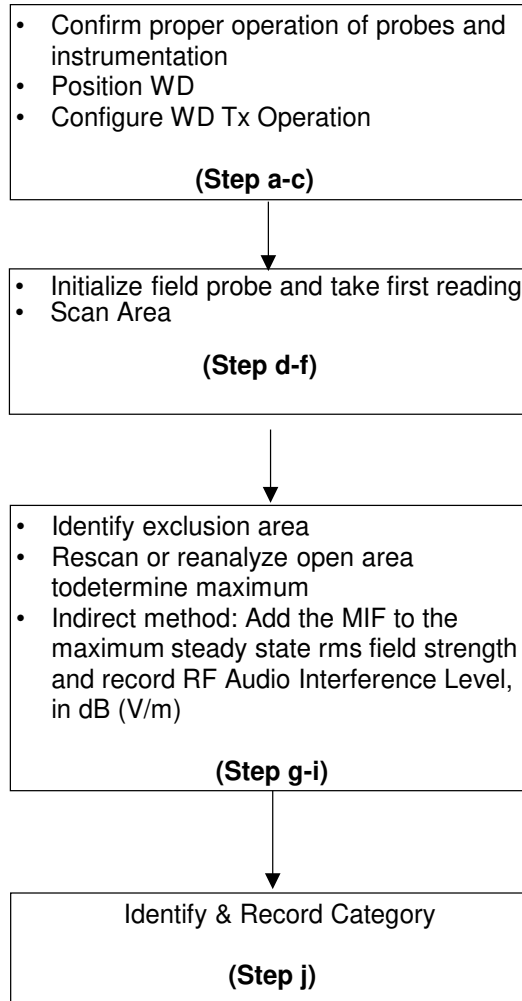

## 11. RF Emissions Measurement Criteria

WD RF audio interference level categories in logarithmic units

Emission Categories	E-field emissions	
	< 960 MHz	> 960 MHz
Category M1	50 to 55 dB (V/m)	40 to 45 dB (V/m)
Category M2	45 to 50 dB (V/m)	35 to 40 dB (V/m)
Category M3	40 to 45 dB (V/m)	30 to 35 dB (V/m)
Category M4	<40 dB (V/m)	<30 dB (V/m)

## 12. HAC (RF Emissions) Test Results

MIF values were not tested by a probe or as specified in the standards but are based on analysis provided by SPEAG for the following User Identifiers and air interfaces.

The data included in this report are for the worst case operating modes. Refer to Appendix D and G for the MIF values that represent the worst case operation modes.

Air-Interface	Ch. No.	Freq. (MHz)	Results* (dB V/m)	Results plus 0.2dB uncertainty (dB V/m)	M-Rating	Plots Page #
CDMA2000 BC0	1013	824.70	29.70	29.90	M4	1
	384	836.60	29.31	29.51	M4	2
	777	848.31	28.85	29.05	M4	3
CDMA2000 BC1	25	1851.25	24.36	24.56	M4	4
	600	1880.00	<b>24.84</b>	<b>25.04</b>	<b>M4</b>	5
	1175	1908.75	23.26	23.46	M4	6
Wi-Fi & LTE-FDD	Refer to Section 7 Evaluation for Low-power Exemption. RF Emission testing for this device is required only for CDMA voice mode. All other applicable air-interfaces are exempt from testing in accordance with C63.19-2011 Clause 4.4 and are rated M4.				M4	N/A

### Note(s):

\*: Measured Audio Interference level in dB (V/m); indirect method (max rms field strength Plus MIF)



## 12.1. Worst Case RF Emission Test Plot

Test Laboratory: UL Verification Services Inc., SAR Lab 2

Date: 1/13/2016

### HAC-RF Emission

Communication System: UID 10295 - AAA, CDMA2000, RC1, SO3, 1/8th Rate 25 fr.; Frequency: 1880 MHz; Duty Cycle: 1:17.7419

Phantom section: RF Section

DASY5 Configuration:

- Probe: ER3DV6 - SN2509; ConvF(1, 1, 1); Calibrated: 5/14/2015;
- Sensor-Surface: (Fix Surface)
- Electronics: DAE4 Sn1257; Calibrated: 9/16/2015
- Phantom: HAC Test Arch with AMCC; Type: SD HAC P01 BB
- Measurement SW: DASY52, Version 52.8 (7);SEMCAD X Version 14.6.10 (7164)

### CDMA BC1 E-Field measurement/RC1\_SO3\_Ch 600/Hearing Aid Compatibility Test (101x101x1):

Interpolated grid: dx=0.5000 mm, dy=0.5000 mm

Device Reference Point: 0, 0, -6.3 mm

Reference Value = 11.47 V/m; Power Drift = 0.22 dB

Applied MIF = 3.26 dB

RF audio interference level = 24.84 dBV/m

Emission category: **M4**

MIF scaled E-field

Grid 1 M4 22.8 dBV/m	Grid 2 M4 23.29 dBV/m	Grid 3 M4 22.46 dBV/m
Grid 4 M4 21.94 dBV/m	Grid 5 M4 24.84 dBV/m	Grid 6 M4 24.77 dBV/m
Grid 7 M4 24.95 dBV/m	Grid 8 M4 26.75 dBV/m	Grid 9 M4 26.42 dBV/m

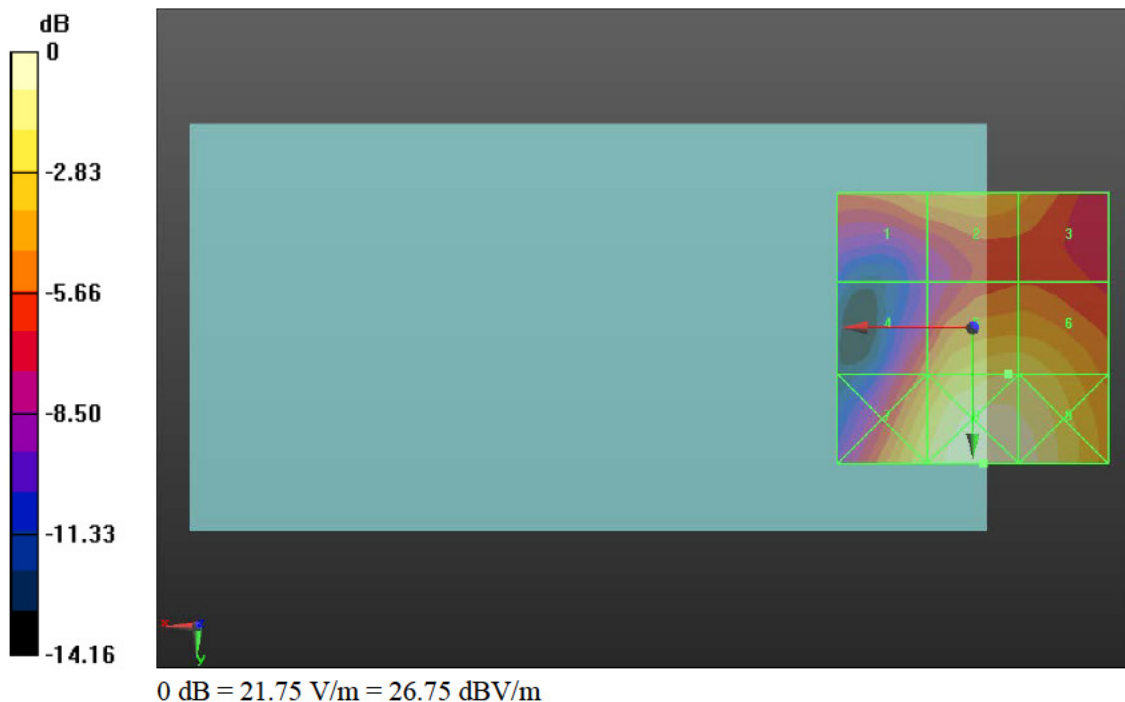



## **Appendixes**

**Refer to separated files for the following appendixes**

**16I22653-S3V1 HAC\_RF\_App A Setup Photo**

**16I22653-S3V1 HAC\_RF\_App B System Validation Plots**

**16I22653-S3V1 HAC\_RF\_App C RF Emissions Test Plots**

**16I22653-S3V1 HAC\_RF\_App D MIF Attestation Letter**

**16I22653-S3V1 HAC\_RF\_App E Probe Cal. Certificate**

**16I22653-S3V1 HAC\_RF\_App F Dipole Cal. Certificates**

**16I22653-S3V1 HAC\_RF\_App G UID Specification**

**END OF REPORT**