



FCC CFR47 PART 15 SUBPART C

**BLUETOOTH LOW ENERGY
C2PC CERTIFICATION TEST REPORT**

FOR

GSM/CDMA/LTE PHONE WITH BT & DTS WLAN b/g/n

MODEL NUMBER: LG-L61AL, L61AL, LGL61AL

FCC ID: ZNFL61AL

REPORT NUMBER: 16I22652-E3V1

ISSUE DATE: 1/29/2016

Prepared for
LG ELECTRONICS MOBILECOMM U.S.A., INC
1000 SYLVAN AVENUE
ENGLEWOOD CLIFFS,
NEW JERSEY, 07632, U.S.A

Prepared by
UL VERIFICATION SERVICES INC.
47173 BENICIA STREET
FREMONT, CA 94538, U.S.A.
TEL: (510) 771-1000
FAX: (510) 661-0888



NVLAP LAB CODE 200065-0

Revision History

<u>Rev.</u>	<u>Issue Date</u>	<u>Revisions</u>	<u>Revised By</u>
V1	1/29/2016	Initial Issue	D. CORONIA

TABLE OF CONTENTS

1. ATTESTATION OF TEST RESULTS	4
2. TEST METHODOLOGY	5
3. FACILITIES AND ACCREDITATION	5
4. CALIBRATION AND UNCERTAINTY	5
4.1. <i>MEASURING INSTRUMENT CALIBRATION</i>	<i>5</i>
4.2. <i>SAMPLE CALCULATION</i>	<i>5</i>
4.3. <i>MEASUREMENT UNCERTAINTY.....</i>	<i>6</i>
5. EQUIPMENT UNDER TEST	7
5.1. <i>DESCRIPTION OF EUT</i>	<i>7</i>
5.2. <i>MAXIMUM OUTPUT POWER.....</i>	<i>7</i>
5.3. <i>DESCRIPTION OF AVAILABLE ANTENNAS</i>	<i>7</i>
5.4. <i>WORST-CASE CONFIGURATION AND MODE.....</i>	<i>7</i>
5.5. <i>DESCRIPTION OF TEST SETUP.....</i>	<i>8</i>
6. TEST AND MEASUREMENT EQUIPMENT	10
7. SUMMARY TABLE	11
8. ANTENNA PORT TEST RESULTS	12
8.1. <i>ON TIME, DUTY CYCLE AND MEASUREMENTS METHODS.....</i>	<i>12</i>
9. RADIATED EMISSION TEST	13
9.1. <i>TRANSMITTER ABOVE 1 GHz.....</i>	<i>14</i>
9.2. <i>WORST-CASE BELOW 1 GHz.....</i>	<i>24</i>
10. SETUP PHOTOS	26

1. ATTESTATION OF TEST RESULTS

COMPANY NAME: LG ELECTRONICS MOBILECOMM U.S.A., INC.
EUT DESCRIPTION: GSM/WCDMA/LTE PHONE WITH BT & DTS WLAN b/g/n
MODEL: LG-L61AL, L61AL, LGL61AL
SERIAL NUMBER: 601KPHG000625, 601KPPB000624
DATE TESTED: JANUARY 19-22, 2016

APPLICABLE STANDARDS	
STANDARD	TEST RESULTS
CFR 47 Part 15 Subpart C	Pass

UL Verification Services Inc. tested the above equipment in accordance with the requirements set forth in the above standards. All indications of Pass/Fail in this report are opinions expressed by UL Verification Services Inc. based on interpretations and/or observations of test results. Measurement Uncertainties were not taken into account and are published for informational purposes only. The test results show that the equipment tested is capable of demonstrating compliance with the requirements as documented in this report.

Note: The results documented in this report apply only to the tested sample, under the conditions and modes of operation as described herein. This document may not be altered or revised in any way unless done so by UL Verification Services Inc. and all revisions are duly noted in the revision section. Any alteration of this document not carried out by UL Verification Services Inc. will constitute fraud and shall nullify the document. This report must not be used by the client to claim product certification, approval, or endorsement by NVLAP, NIST, any agency of the Federal Government, or any agency of any government.

Approved & Released For
UL Verification Services Inc. By:

Tested By:

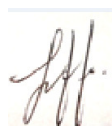

DAN CORONIA
WISE PROJECT LEAD
CONSUMER TECHNOLOGY DIVISION
UL VERIFICATION SERVICES INC

JEFFREY WU
WISE ENGINEER
CONSUMER TECHNOLOGY DIVISION
UL VERIFICATION SERVICES INC

2. TEST METHODOLOGY

The tests documented in this report were performed in accordance with FCC CFR 47 Part 2, FCC CFR 47 Part 15, and KDB 558074 D01 v03r04, ANSI C63.10-2013.

3. FACILITIES AND ACCREDITATION

The test sites and measurement facilities used to collect data are located at 47173 and 47266 Benicia Street, Fremont, California, USA. Line conducted emissions are measured only at the 47173 address. The following table identifies which facilities were utilized for radiated emission measurements documented in this report. Specific facilities are also identified in the test results sections.

47173 Benicia Street	47266 Benicia Street
<input checked="" type="checkbox"/> Chamber A	<input type="checkbox"/> Chamber D
<input type="checkbox"/> Chamber B	<input type="checkbox"/> Chamber E
<input checked="" type="checkbox"/> Chamber C	<input type="checkbox"/> Chamber F
	<input type="checkbox"/> Chamber G
	<input type="checkbox"/> Chamber H

The above test sites and facilities are covered under FCC Test Firm Registration # 208313.

UL Verification Services Inc. is accredited by NVLAP, Laboratory Code 200065-0.

Chambers A through H are covered under Industry Canada company address code 2324B with site numbers 2324B -1 through 2324B-8, respectively.

4. CALIBRATION AND UNCERTAINTY

4.1. MEASURING INSTRUMENT CALIBRATION

The measuring equipment utilized to perform the tests documented in this report has been calibrated in accordance with the manufacturer's recommendations, and is traceable to recognized national standards.

4.2. SAMPLE CALCULATION

Where relevant, the following sample calculation is provided:

$$\begin{aligned} \text{Field Strength (dBuV/m)} &= \text{Measured Voltage (dBuV)} + \text{Antenna Factor (dB/m)} + \\ &\text{Cable Loss (dB)} - \text{Preamp Gain (dB)} \\ 36.5 \text{ dBuV} + 18.7 \text{ dB/m} + 0.6 \text{ dB} - 26.9 \text{ dB} &= 28.9 \text{ dBuV/m} \end{aligned}$$

4.3. MEASUREMENT UNCERTAINTY

Where relevant, the following measurement uncertainty levels have been estimated for tests performed on the apparatus:

PARAMETER	UNCERTAINTY
Conducted Disturbance, 0.15 to 30 MHz	3.52 dB
Radiated Disturbance, 9KHz to 30 MHz	2.14 dB
Radiated Disturbance, 30 to 1000 MHz	4.98 dB
Radiated Disturbance, 1000 to 6000 MHz	3.86 dB
Radiated Disturbance, 6000 to 18000 MHz	4.23 dB
Radiated Disturbance, 18000 to 26000 MHz	5.30 dB
Radiated Disturbance, 26000 to 40000 MHz	5.23 dB

Uncertainty figures are valid to a confidence level of 95%.

5. EQUIPMENT UNDER TEST

5.1. DESCRIPTION OF EUT

The EUT is a GSM/WCDMA/LTE PHONE WITH BT & DTS WLAN b/g/n

5.2. MAXIMUM OUTPUT POWER

See original report for details.

5.3. DESCRIPTION OF AVAILABLE ANTENNAS

The radio utilizes an FPCB antenna, with a maximum gain of 0.24 dBi.

5.4. WORST-CASE CONFIGURATION AND MODE

Radiated emission and power line conducted emission were performed with the EUT set to transmit on the channel with higher output power as worst-case scenario.

The fundamental of the EUT was investigated in three orthogonal orientations X, Y, Z it was determined that X orientation was worst-case orientation; therefore, all final radiated testing was performed with the EUT in X orientation.

5.5. DESCRIPTION OF TEST SETUP

SUPPORT EQUIPMENT

Support Equipment List				
Description	Manufacturer	Model	Serial Number	FCC ID
AC Adapter	LG	DC1507	EAD62377906	N/A
Earphone	LG	N/A	N/A	N/A

I/O CABLES

I/O Cable List						
Cable No	Port	# of identical ports	Connector Type	Cable Type	Cable Length (m)	Remarks
1	DC Power	1	Mini-USB	Shielded	1.2m	N/A
2	Audio	1	Mini-Jack	Unshielded	1m	N/A

TEST SETUP

EUT was set in the Hidden menu mode to enable BLE communications.

SETUP DIAGRAM FOR TESTS

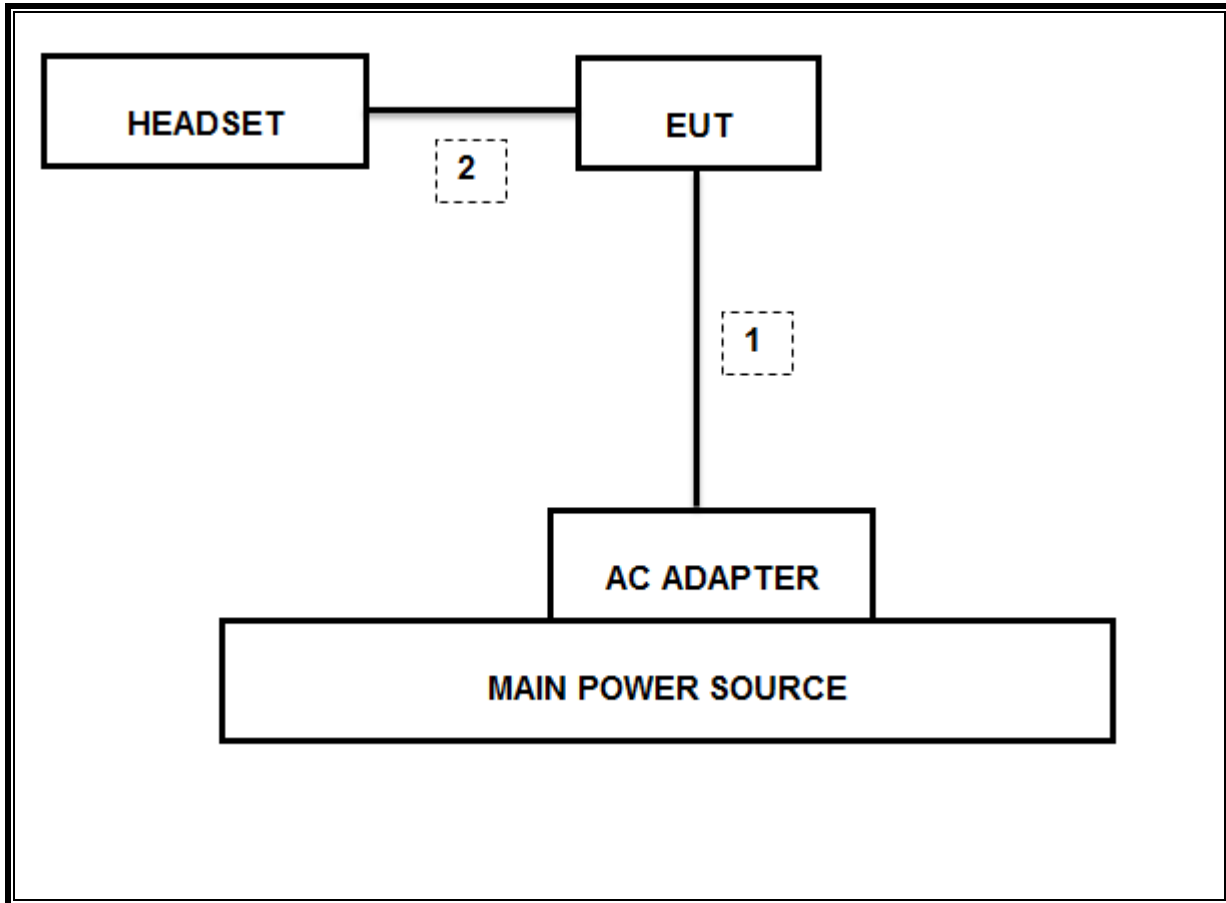

6. TEST AND MEASUREMENT EQUIPMENT

The following test and measurement equipment was utilized for the tests documented in this report:

Test Equipment List				
Description	Manufacturer	Model	T Number	Cal Due
Antenna, Biconolog, 30MHz-1 GHz	Sunol Sciences	JB1	130	09/01/16
Antenna, Horn, 18GHz	ETS Lindgren	3117	345	03/03/16
Antenna, Horn, 26.5 GHz	ARA	MWH-1826/B	447	05/12/16
RF Preamplifier, 1GHz - 18GHz	Miteq	NSP4000-SP2	88	04/07/16
RF Preamplifier, 1GHz - 26.5GHz	HP	8449B	404	06/29/16
Amplifier, 10KHz to 1 GHz	Keysight	8447D	15	08/14/16
Spectrum Analyzer, PXA, 3 Hz to 44 GHz	Keysight	N9030A	907	01/06/17
Low Pass Filter 5GHz	Micro-Tronics	LPS17541	417	05/04/16
High Pass Filter 6GHz	Micro-Tronics	HPS17542	893	04/25/16
High Pass Filter 3GHz	Micro-Tronics	HPS17543	898	04/25/16

Test Software List			
Description	Manufacturer	Model	Version
Radiated Software	UL	UL EMC	Version 9.5, June 24, 2015

7. SUMMARY TABLE

C2PC Reason: Please see LG-L61AL FCC Class II change description for details.

FCC Part Section	RSS Section(s)	Test Description	Test Limit	Test Condition	Test Result
15.247 (a)(2)	RSS-247 5.2.1	Occupied Bandwidth (6dB)	>500KHz	Conducted	See Original
2.1051, 15.247 (d)	RSS-247 5.5	Band Edge / Conducted Spurious Emission	-20dBc		See Original
15.247	RSS-247 5.4.4	TX conducted output power	<30dBm		See Original
15.247	RSS-247 5.2.2	PSD	<8dBm		See Original
15.207 (a)	RSS-GEN 8.8	AC Power Line conducted emissions	Section 10	Radiated	See Original
15.205, 15.209	RSS-GEN 8.9/7	Radiated Spurious Emission	< 54dBuV/m		Pass

8. ANTENNA PORT TEST RESULTS

8.1. ON TIME, DUTY CYCLE AND MEASUREMENTS METHODS

LIMITS

None; for reporting purposes only.

PROCEDURE

KDB 558074 Zero-Span Spectrum Analyzer Method.

Mode	ON Time B (msec)	Period (msec)	Duty Cycle x (linear)	Duty Cycle (%)	Duty Cycle Correction Factor (dB)	1/T Minimum VBW (kHz)
BLE	0.391	0.625	0.626	62.56%	2.04	2.558

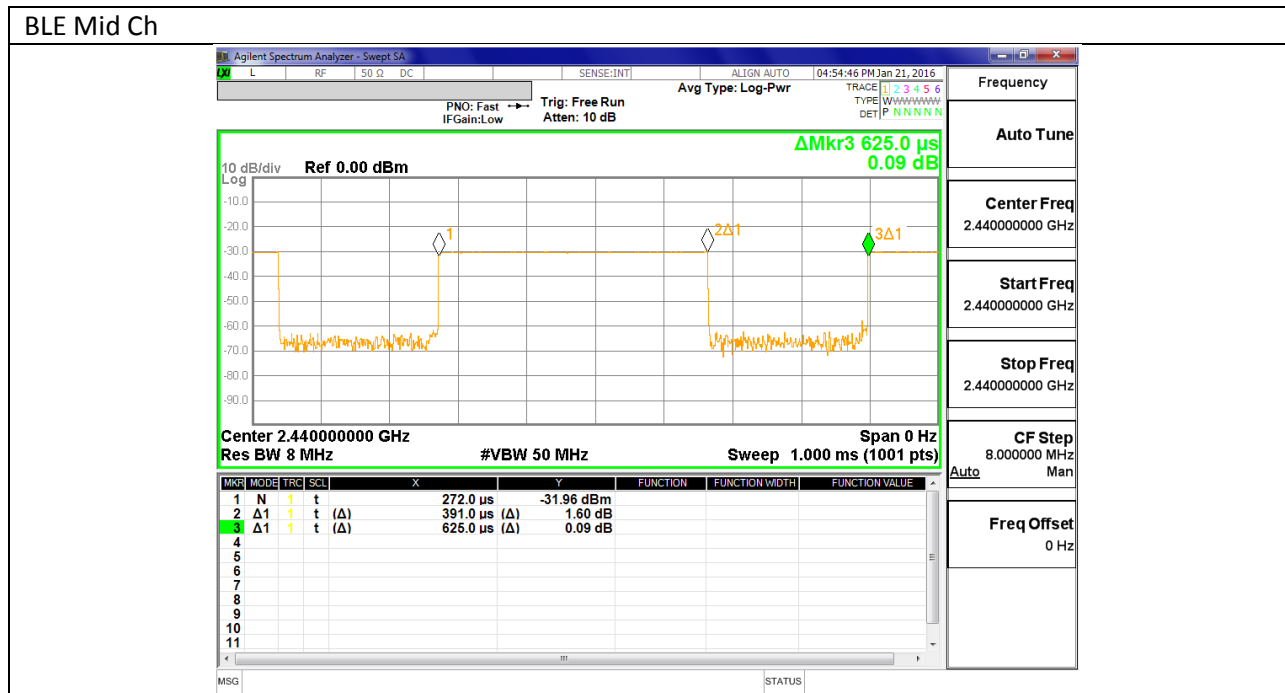

9. RADIATED EMISSION TEST

LIMITS

FCC §15.205 and §15.209

Frequency Range (MHz)	Field Strength Limit (uV/m) at 3 m	Field Strength Limit (dBuV/m) at 3 m
30 - 88	100	40
88 - 216	150	43.5
216 - 960	200	46
Above 960	500	54

TEST PROCEDURE

The EUT is placed on a non-conducting table 80 cm above the ground plane for below 1GHz and 150cm for above 1GHz. The antenna to EUT distance is 3 meters. The EUT is configured in accordance with ANSI C63.10. The EUT is set to transmit in a continuous mode.

For measurements below 1 GHz the resolution bandwidth is set to 100 kHz for peak detection measurements or 120 kHz for quasi-peak detection measurements. Peak detection is used unless otherwise noted as quasi-peak.

For measurements above 1 GHz the resolution bandwidth is set to 1 MHz, then the video bandwidth is set to 1 MHz for peak measurements and add duty cycle factor for average measurements. Duty cycle factor = $10 \log (1/x)$. For example: DCF = $10 \log (1/0.625) = 2.04\text{dB}$.

The spectrum from 30 MHz to 26 GHz is investigated with the transmitter set to the lowest, middle, and highest channels in the 2.4 GHz band.

The frequency range of interest is monitored at a fixed antenna height and EUT azimuth. The EUT is rotated through 360 degrees to maximize emissions received. The antenna is scanned from 1 to 4 meters above the ground plane to further maximize the emission. Measurements are made with the antenna polarized in both the vertical and the horizontal positions.

9.1. TRANSMITTER ABOVE 1 GHz RESTRICTED BANDEDGE (LOW CHANNEL)

HORIZONTAL PEAK AND AVERAGE PLOT

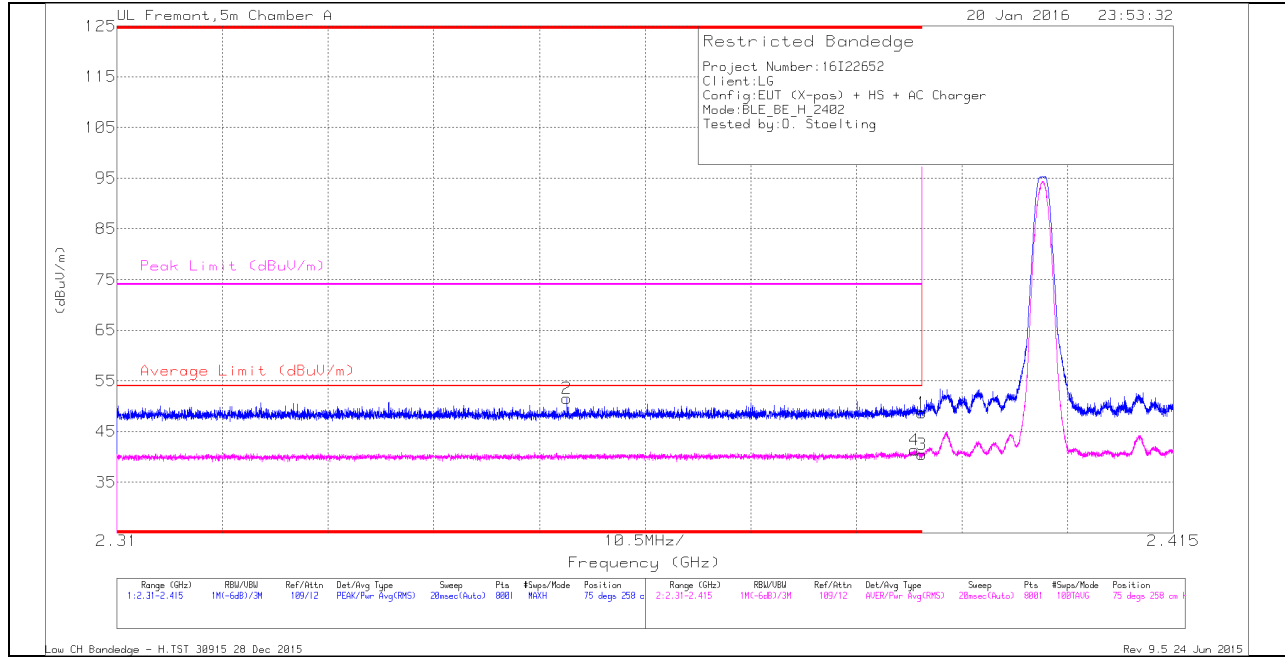

HORIZONTAL DATA

Marker	Frequency (GHz)	Meter Reading (dBuV)	Det	AF T345 (dB/m)	Amp/Cbl/Fit r/Pad (dB)	DC Corr (dB)	Corrected Reading (dBuV/m)	Average Limit (dBuV/m)	Margin (dB)	Peak Limit (dBuV/m)	PK Margin (dB)	Azimuth (Degs)	Height (cm)	Polarity
2	* 2.355	39.44	Pk	31.9	-19.8	0	51.54	-	-	74	-22.46	75	258	H
4	* 2.389	27.24	RMS	32	-19.9	2.04	41.38	54	-12.62	-	-	75	258	H
1	* 2.39	36.61	Pk	32	-19.9	0	48.71	-	-	74	-25.29	75	258	H
3	* 2.39	26.35	RMS	32	-19.9	2.04	40.49	54	-13.51	-	-	75	258	H

* - indicates frequency in 47 CFR §15.205/IC RSS-GEN §8.10 Restricted Band

Pk - Peak detector

RMS - RMS detection

Low CH Bandedge - H.TST 30915 28 Dec 2015

Rev 9.5 24 Jun 2015

VERTICAL PEAK AND AVERAGE PLOT

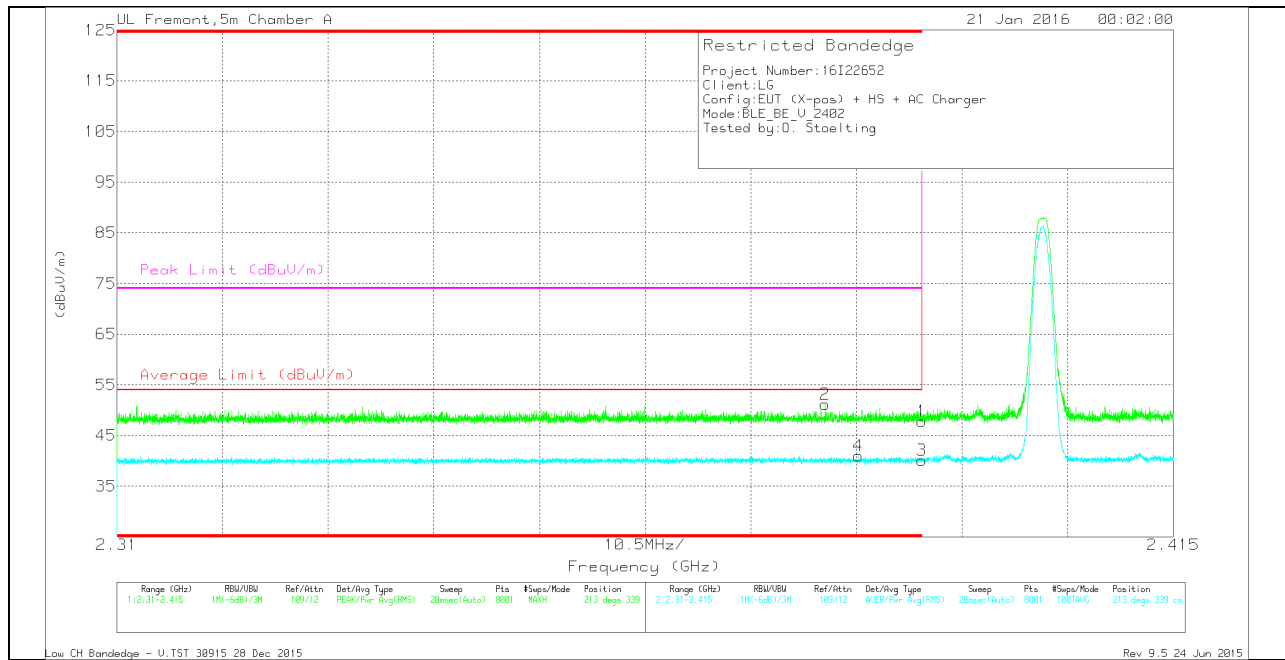

VERTICAL DATA

Marker	Frequency (GHz)	Meter Reading (dBuV)	Det	AF T345 (dB/m)	Amp/Cbl/Fit r/Pad (dB)	DC Corr (dB)	Corrected Reading (dBuV/m)	Average Limit (dBuV/m)	Margin (dB)	Peak Limit (dBuV/m)	PK Margin (dB)	Azimuth (Degs)	Height (cm)	Polarity
2	* 2.38	39.09	Pk	31.9	-19.8	0	51.19	-	-	74	-22.81	213	339	V
4	* 2.384	26.99	RMS	31.9	-19.9	2.04	41.03	54	-12.97	-	-	213	339	V
1	* 2.39	35.66	Pk	32	-19.9	0	47.76	-	-	74	-26.24	213	339	V
3	* 2.39	25.96	RMS	32	-19.9	2.04	40.1	54	-13.9	-	-	213	339	V

* - indicates frequency in 47 CFR §15.205/IC RSS-GEN §8.10 Restricted Band

Pk - Peak detector

RMS - RMS detection

AUTHORIZED BANDEDGE (HIGH CHANNEL)

HORIZONTAL PEAK AND AVERAGE PLOT

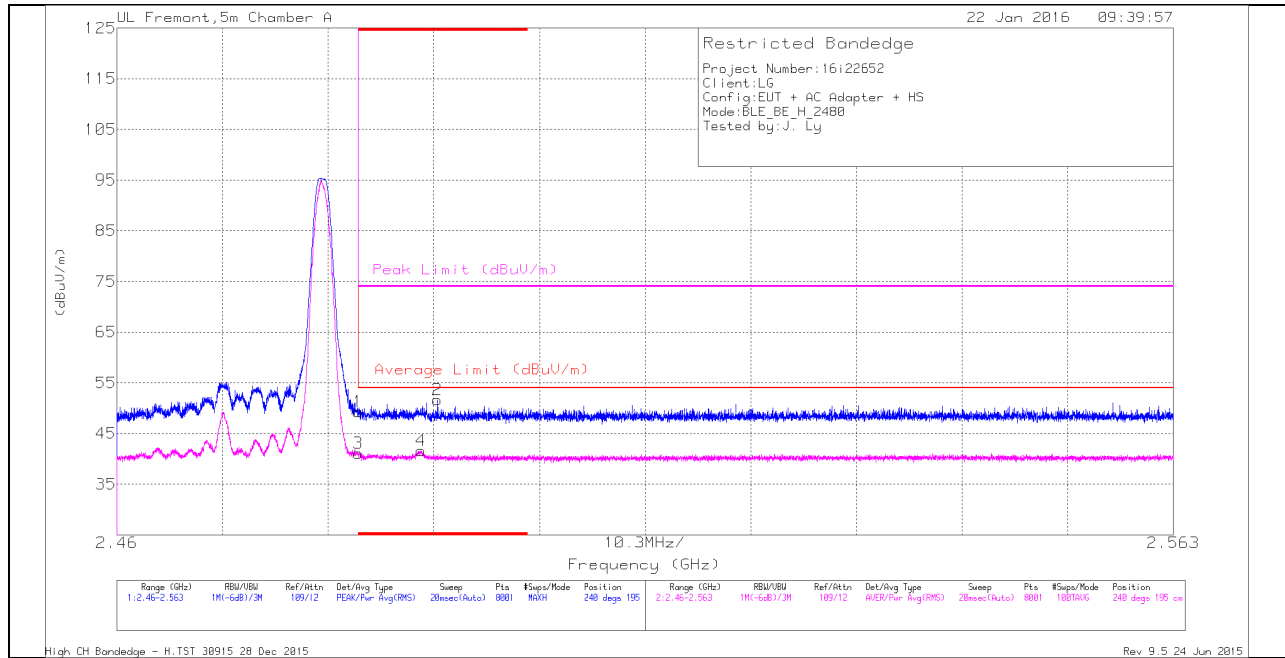

HORIZONTAL DATA

Marker	Frequency (GHz)	Meter Reading (dBuV)	Det	AF T345 (dB/m)	Amp/Cb/Filter/Pad (dB)	DC Corr (dB)	Corrected Reading (dBuV/m)	Average Limit (dBuV/m)	Margin (dB)	Peak Limit (dBuV/m)	PK Margin (dB)	Azimuth (Degs)	Height (cm)	Polarity
1	* 2.484	37.22	Pk	32.1	-20	0	49.32	-	-	74	-24.68	240	195	H
2	* 2.491	39.64	Pk	32.1	-20.1	0	51.64	-	-	74	-22.36	240	195	H
3	* 2.484	26.93	RMS	32.1	-20	2.04	41.07	54	-12.93	-	-	240	195	H
4	* 2.49	27.44	RMS	32.1	-20	2.04	41.58	54	-12.42	-	-	240	195	H

* - indicates frequency in 47 CFR §15.205/IC RSS-GEN §8.10 Restricted Band

Pk - Peak detector

RMS - RMS detection

VERTICAL PEAK AND AVERAGE PLOT

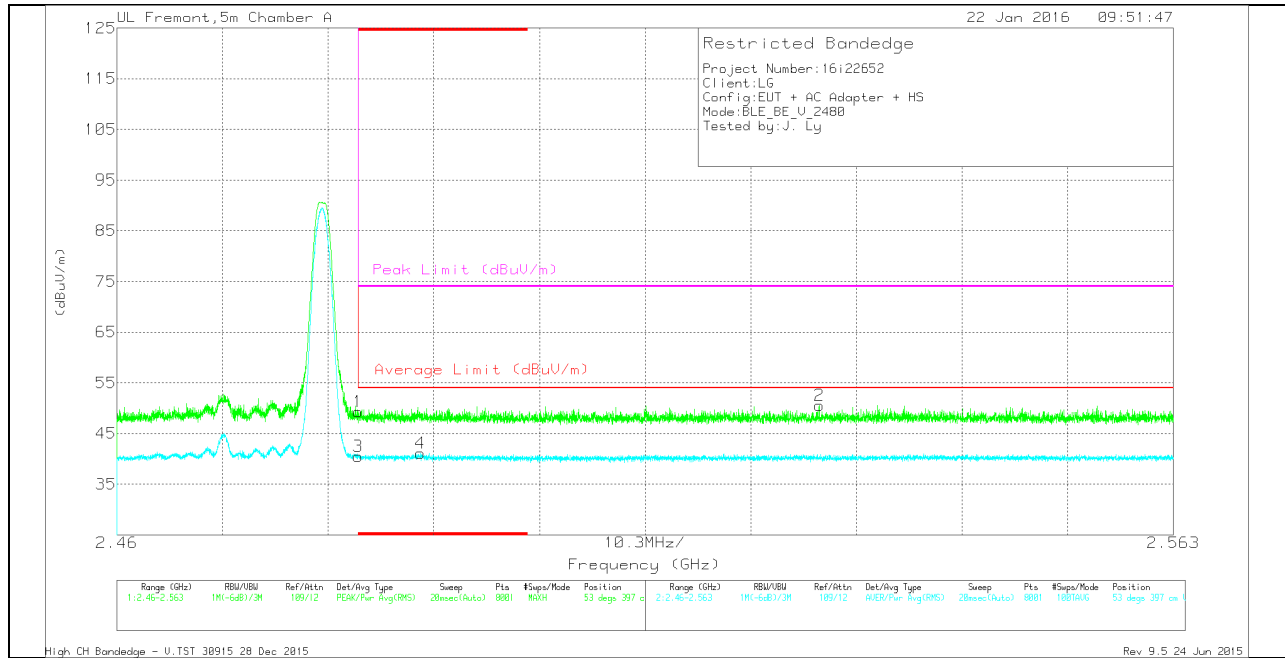

VERTICAL DATA

Marker	Frequency (GHz)	Meter Reading (dBuV)	Det	AF T345 (dB/m)	Amp/Cbl/Fitter/Pad (dB)	DC Corr (dB)	Corrected Reading (dBuV/m)	Average Limit (dBuV/m)	Margin (dB)	Peak Limit (dBuV/m)	PK Margin (dB)	Azimuth (Degs)	Height (cm)	Polarity
1	* 2.484	37.15	Pk	32.1	-20	0	49.25	-	-	74	-24.75	53	397	V
3	* 2.484	26.32	RMS	32.1	-20	2.04	40.46	54	-13.54	-	-	53	397	V
4	* 2.49	26.93	RMS	32.1	-20	2.04	41.07	54	-12.93	-	-	53	397	V
2	2.528	38.54	Pk	32.1	-20.1	0	50.54	-	-	74	-23.46	53	397	V

* - indicates frequency in 47 CFR §15.205/IC RSS-GEN §8.10 Restricted Band

Pk - Peak detector

RMS - RMS detection

HARMONICS AND SPURIOUS EMISSIONS LOW CHANNEL HORIZONTAL

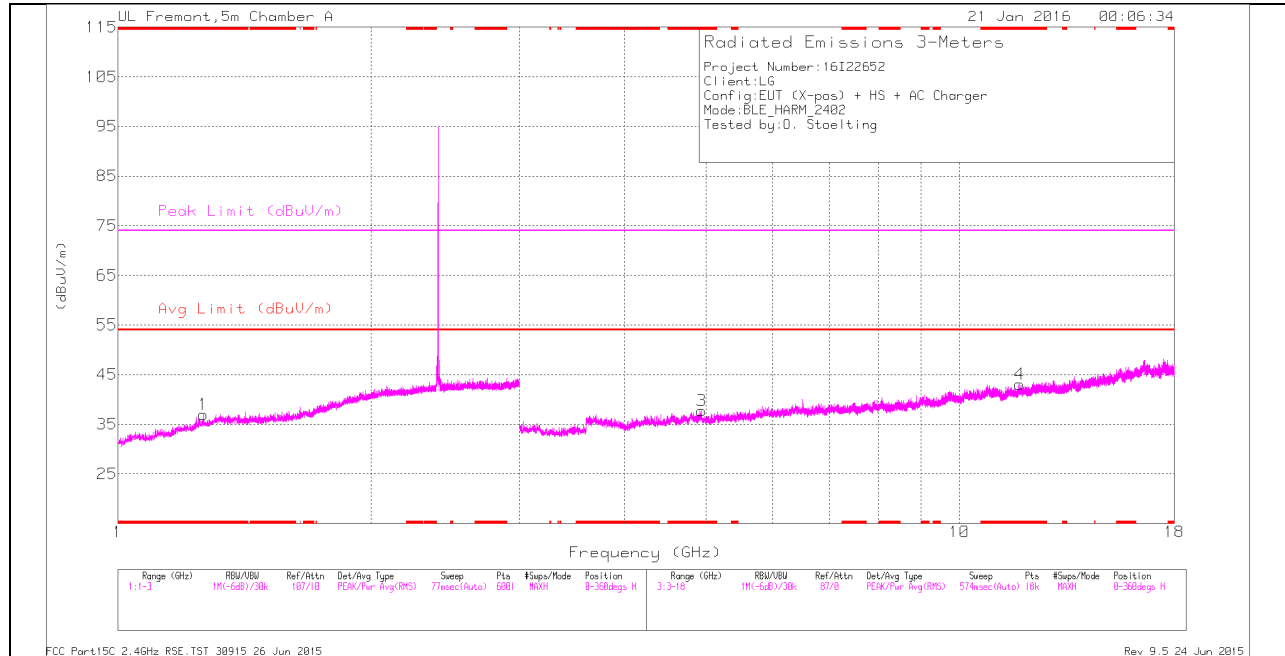

Note: Emission was scanned up to 26GHz; No emissions were detected above the noise floor which was at least 20dB below the specification limit.

LOW CHANNEL VERTICAL

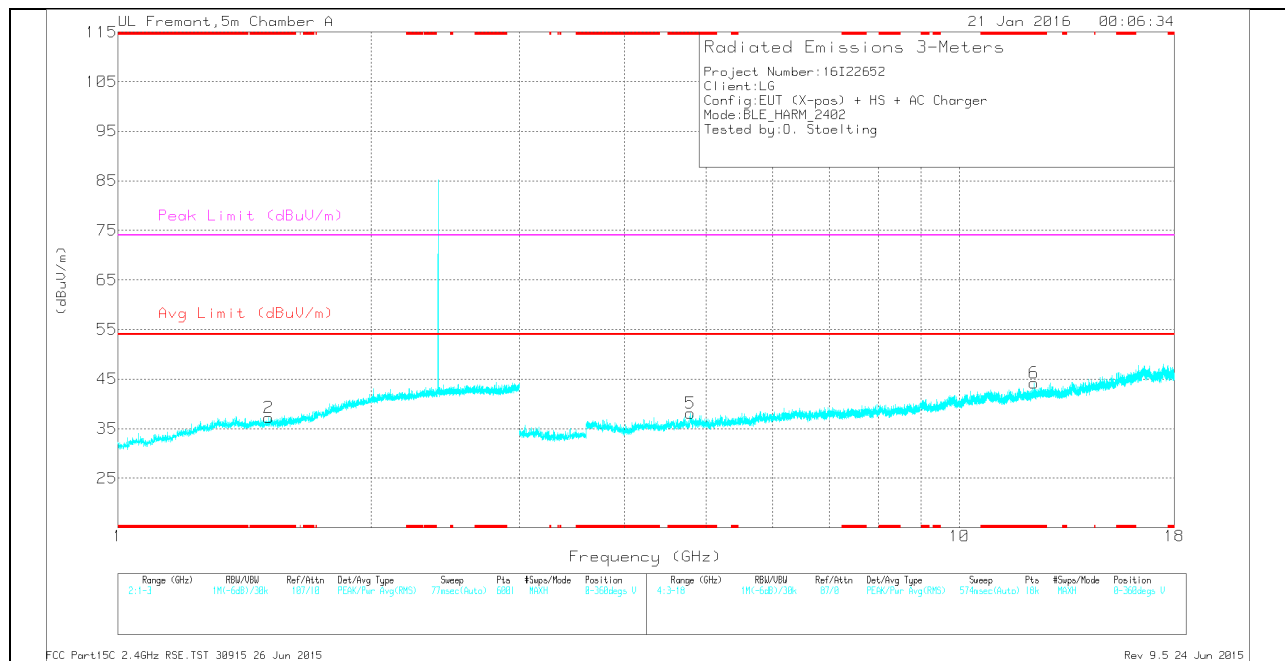

Note: Emission was scanned up to 26GHz; No emissions were detected above the noise floor which was at least 20dB below the specification limit.

LOW CHANNEL DATA

Trace Markers

Marker	Frequency (GHz)	Meter Reading (dBuV)	Det	AF T345 (dB/m)	Amp/Cb/Ftr /Pad (dB)	DC Corr (dB)	Corrected Reading (dBuV/m)	Avg Limit (dBuV/m)	Margin (dB)	Peak Limit (dBuV/m)	PK Margin (dB)	Azimuth (Degs)	Height (cm)	Polarity
1	* 1.263	29.87	Pk	28.5	-21.4	0	36.97	-	-	74	-37.03	0-360	201	H
2	* 1.51	29.37	Pk	28.1	-20.2	0	37.27	-	-	74	-36.73	0-360	200	V
4	* 11.781	26.62	Pk	38.3	-21.9	0	43.02	-	-	74	-30.98	0-360	201	H
6	* 12.254	27.39	Pk	38.9	-22.1	0	44.19	-	-	74	-29.81	0-360	200	V
5	* 4.79	33.98	Pk	34	-29.9	0	38.08	-	-	74	-35.92	0-360	200	V
3	* 4.938	33.52	Pk	33.9	-29.7	0	37.72	-	-	74	-36.28	0-360	100	H

* - indicates frequency in 47 CFR §15.205/IC RSS-GEN §8.10 Restricted Band

Pk - Peak detector

Radiated Emissions

Frequency (GHz)	Meter Reading (dBuV)	Det	AF T345 (dB/m)	Amp/Cb/Ftr /Pad (dB)	DC Corr (dB)	Corrected Reading (dBuV/m)	Avg Limit (dBuV/m)	Margin (dB)	Peak Limit (dBuV/m)	PK Margin (dB)	Azimuth (Degs)	Height (cm)	Polarity
* 1.262	36.4	PK2	28.5	-21.4	0	43.5	-	-	74	-30.5	253	164	H
* 1.261	24.52	MAv1	28.5	-21.4	2.04	33.66	54	-20.34	-	-	253	164	H
* 1.51	36.92	PK2	28.1	-20.2	0	44.82	-	-	74	-29.18	5	260	V
* 1.512	24.77	MAv1	28.1	-20.2	2.04	34.71	54	-19.29	-	-	5	260	V
* 4.937	40.15	PK2	33.9	-29.6	0	44.45	-	-	74	-29.55	189	185	H
* 4.938	28.67	MAv1	33.9	-29.7	2.04	34.91	54	-19.09	-	-	189	185	H
* 11.781	34.51	PK2	38.3	-21.9	0	50.91	-	-	74	-23.09	82	207	H
* 11.779	22.32	MAv1	38.3	-21.9	2.04	40.76	54	-13.24	-	-	82	207	H
* 4.79	41.19	PK2	34	-29.9	0	45.29	-	-	74	-28.71	12	241	V
* 4.792	29.48	MAv1	34	-29.9	2.04	35.62	54	-18.38	-	-	12	241	V
* 12.253	34.33	PK2	38.9	-22.1	0	51.13	-	-	74	-22.87	79	191	V
* 12.256	22.3	MAv1	38.9	-22.1	2.04	41.14	54	-12.86	-	-	79	191	V

* - indicates frequency in 47 CFR §15.205/IC RSS-GEN §8.10 Restricted Band

PK2 - KDB558074 Method: Maximum Peak

MAv1 - KDB558074 Option 1 Maximum RMS Average

MID CHANNEL HORIZONTAL

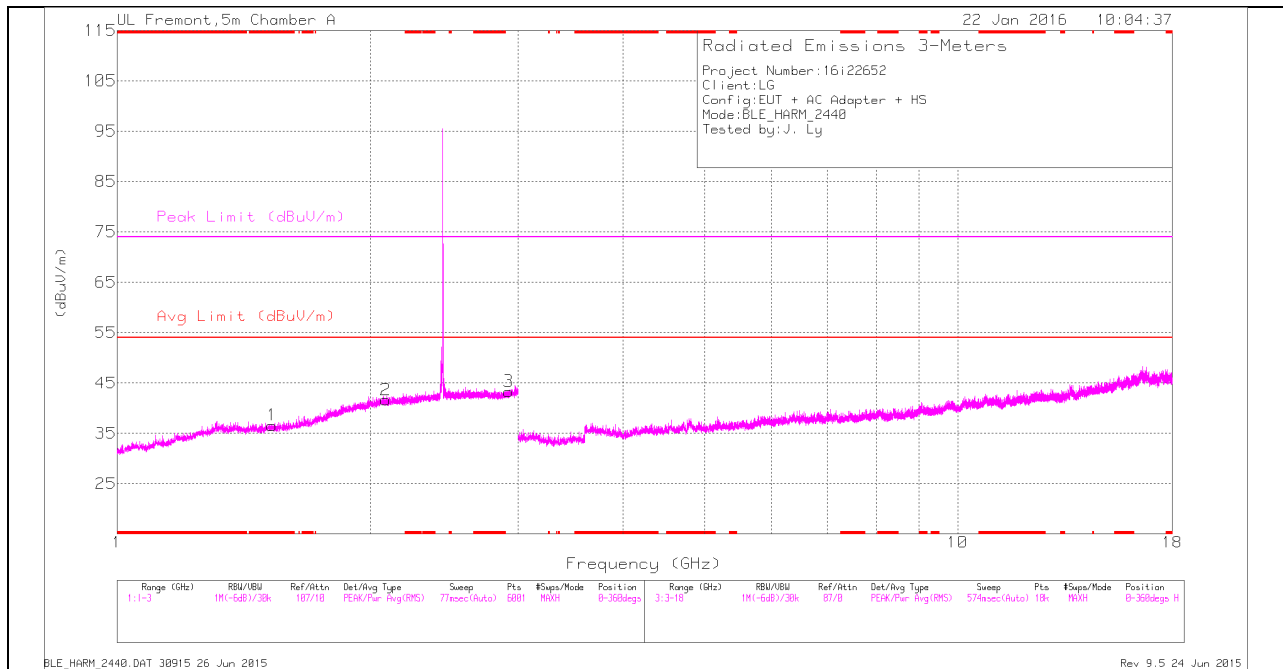

Note: Emission was scanned up to 26GHz; No emissions were detected above the noise floor which was at least 20dB below the specification limit.

MID CHANNEL VERTICAL

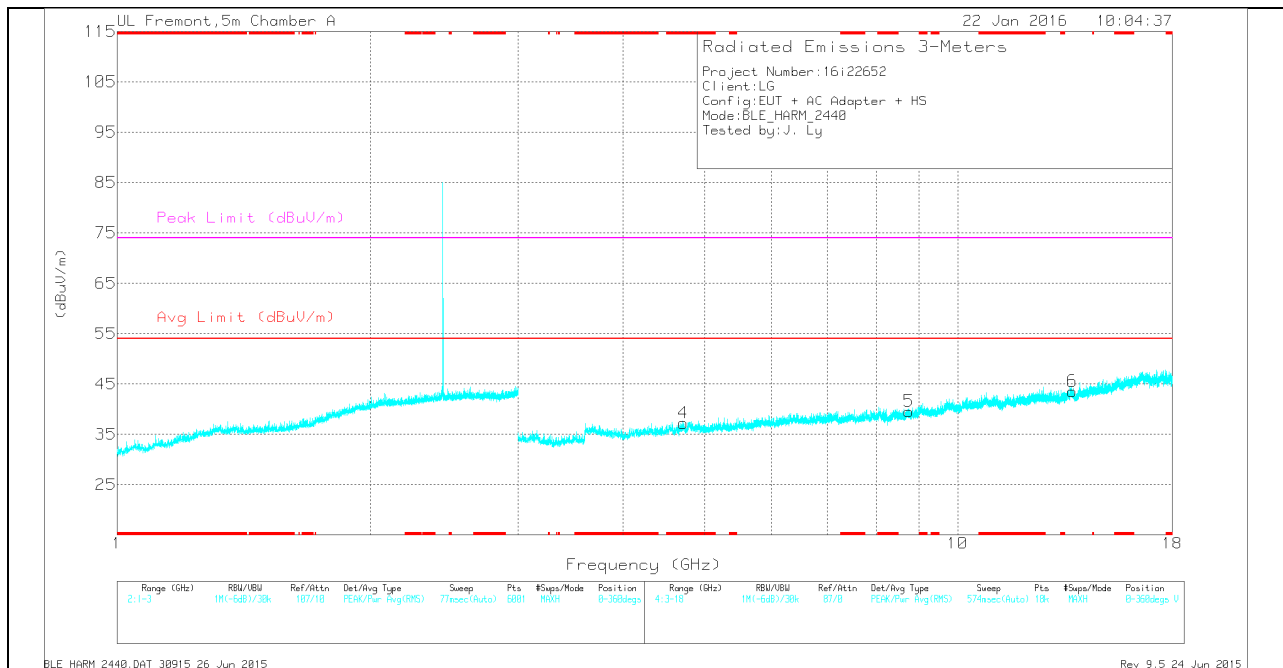

Note: Emission was scanned up to 26GHz; No emissions were detected above the noise floor which was at least 20dB below the specification limit.

MID CHANNEL DATA

Trace Markers

Marker	Frequency (GHz)	Meter Reading (dBuV)	Det	AF T345 (dB/m)	Amp/Cb/Ftr /Pad (dB)	DC Corr (dB)	Corrected Reading (dBuV/m)	Avg Limit (dBuV/m)	Margin (dB)	Peak Limit (dBuV/m)	PK Margin (dB)	Azimuth (Degs)	Height (cm)	Polarity
1	* 1.529	28.69	Pk	28	-20.1	0	36.59	-	-	74	-37.41	0-360	201	H
4	* 4.718	33.83	Pk	34.1	-30.7	0	37.23	-	-	74	-36.77	0-360	100	V
2	2.088	29.76	Pk	31.4	-19.5	0	41.66	-	-	-	-	0-360	100	H
3	2.924	31.11	Pk	32.7	-20.5	0	43.31	-	-	-	-	0-360	100	H
5	8.753	27.47	Pk	36	-23.9	0	39.57	-	-	-	-	0-360	200	V
6	13.686	26.97	Pk	38.8	-22.2	0	43.57	-	-	-	-	0-360	100	V

* - indicates frequency in 47 CFR §15.205/IC RSS-GEN §8.10 Restricted Band

Pk - Peak detector

Radiated Emissions

Frequency (GHz)	Meter Reading (dBuV)	Det	AF T345 (dB/m)	Amp/Cb/Ftr /Pad (dB)	DC Corr (dB)	Corrected Reading (dBuV/m)	Avg Limit (dBuV/m)	Margin (dB)	Peak Limit (dBuV/m)	PK Margin (dB)	Azimuth (Degs)	Height (cm)	Polarity
* 1.529	36.85	PK2	28	-20.1	0	44.75	-	-	74	-29.25	1	100	H
* 1.53	25.08	MAv1	28	-20.1	2.04	35.02	54	-18.92	-	-	1	100	H
* 4.719	41.98	PK2	34.1	-30.7	0	45.38	-	-	74	-28.62	1	100	V
* 4.719	31.03	MAv1	34.1	-30.7	2.04	36.47	54	-17.53	-	-	1	100	V
2.086	25.8	MAv1	31.4	-19.5	2.04	39.74	54	-14.26	-	-	1	100	H
2.089	37.97	PK2	31.4	-19.5	0	49.87	-	-	74	-24.13	1	100	H
2.923	38.9	PK2	32.7	-20.6	0	51	-	-	74	-23	1	100	H
2.925	26.78	MAv1	32.7	-20.5	2.04	41.02	54	-12.98	-	-	1	100	H
8.752	24.64	MAv1	36	-23.9	2.04	38.78	54	-15.22	-	-	1	100	V
8.755	36.14	PK2	36	-23.9	0	48.24	-	-	74	-15.76	1	100	V
13.685	34.86	PK2	38.8	-22.2	0	51.46	-	-	74	-22.54	1	100	V
13.686	23.88	MAv1	38.8	-22.2	2.04	42.52	54	-11.48	-	-	1	100	V

* - indicates frequency in 47 CFR §15.205/IC RSS-GEN §8.10 Restricted Band

PK2 - KDB558074 Method: Maximum Peak

MAv1 - KDB558074 Option 1 Maximum RMS Average

HIGH CHANNEL HORIZONTAL

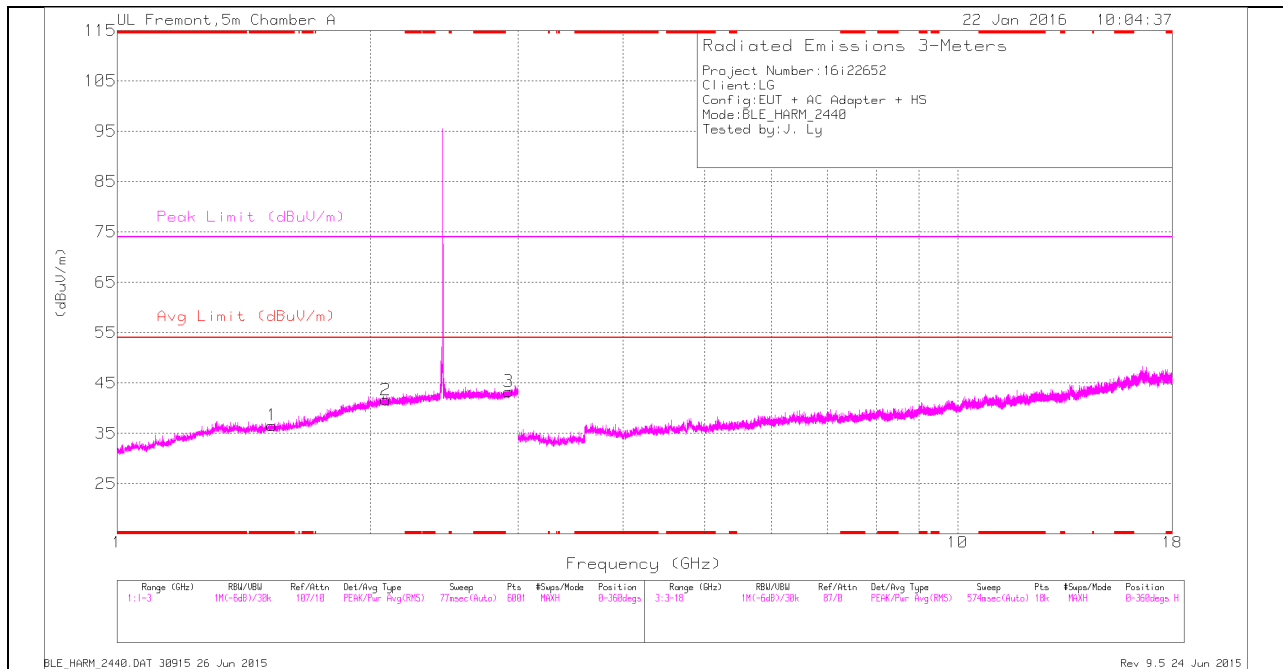

Note: Emission was scanned up to 26GHz; No emissions were detected above the noise floor which was at least 20dB below the specification limit.

HIGH CHANNEL VERTICAL

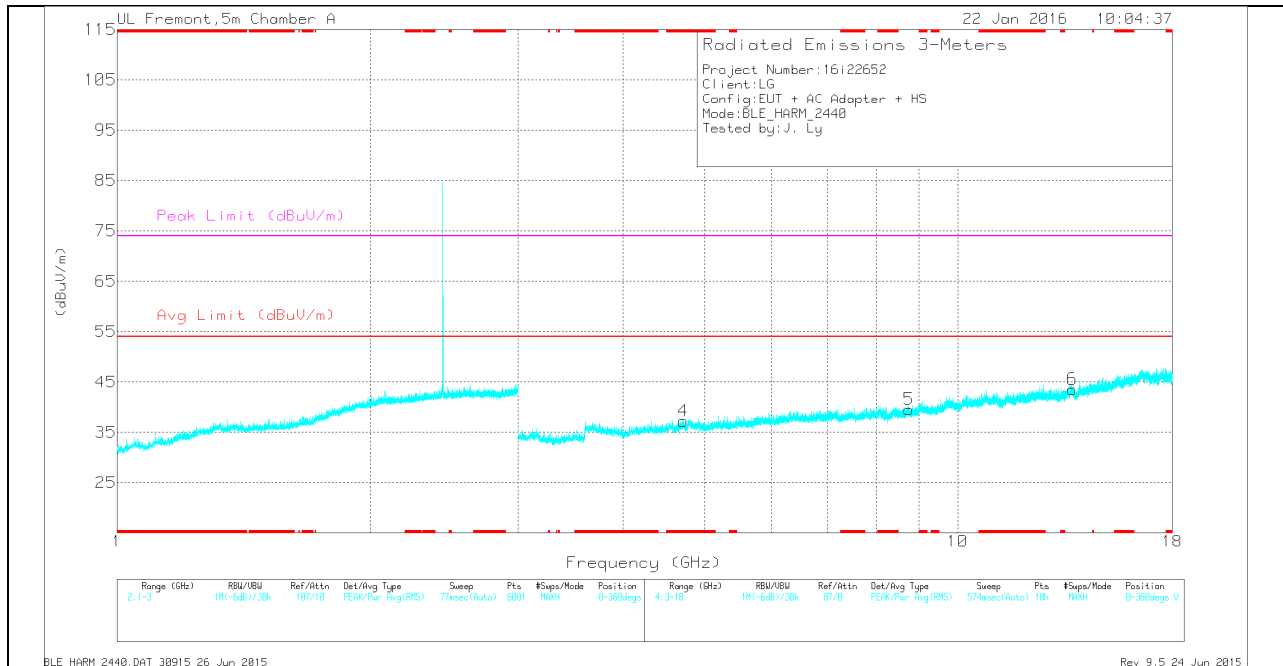

Note: Emission was scanned up to 26GHz; No emissions were detected above the noise floor which was at least 20dB below the specification limit.

HIGH CHANNEL DATA

Trace Markers

Marker	Frequency (GHz)	Meter Reading (dBuV)	Det	AF T345 (dB/m)	Amp/Cbl/Filtr /Pad (dB)	DC Corr (dB)	Corrected Reading (dBuV/m)	Avg Limit (dBuV/m)	Margin (dB)	Peak Limit (dBuV/m)	PK Margin (dB)	Azimuth (Degs)	Height (cm)	Polarity
1	* 1.529	28.69	Pk	28	-20.1	0	36.59	-	-	74	-37.41	0-360	201	H
4	* 4.718	33.83	Pk	34.1	-30.7	0	37.23	-	-	74	-36.77	0-360	100	V
2	2.088	29.76	Pk	31.4	-19.5	0	41.66	-	-	-	-	0-360	100	H
3	2.924	31.11	Pk	32.7	-20.5	0	43.31	-	-	-	-	0-360	100	H
5	8.753	27.47	Pk	36	-23.9	0	39.57	-	-	-	-	0-360	200	V
6	13.686	26.97	Pk	38.8	-22.2	0	43.57	-	-	-	-	0-360	100	V

* - indicates frequency in 47 CFR §15.205/IC RSS-GEN §8.10 Restricted Band

Pk - Peak detector

Radiated Emissions

Frequency (GHz)	Meter Reading (dBuV)	Det	AF T345 (dB/m)	Amp/Cbl/Filtr /Pad (dB)	DC Corr (dB)	Corrected Reading (dBuV/m)	Avg Limit (dBuV/m)	Margin (dB)	Peak Limit (dBuV/m)	PK Margin (dB)	Azimuth (Degs)	Height (cm)	Polarity
* 1.529	36.85	PK2	28	-20.1	0	44.75	-	-	74	-29.25	1	100	H
* 1.53	25.08	MAv1	28	-20.1	2.04	35.02	54	-18.92	-	-	1	100	H
* 4.719	41.98	PK2	34.1	-30.7	0	45.38	-	-	74	-28.62	1	100	V
* 4.719	31.03	MAv1	34.1	-30.7	2.04	36.47	54	-17.53	-	-	1	100	V
2.086	25.8	MAv1	31.4	-19.5	2.04	39.74	54	-14.26	-	-	1	100	H
2.089	37.97	PK2	31.4	-19.5	0	49.87	-	-	74	-24.13	1	100	H
2.923	38.9	PK2	32.7	-20.6	0	51	-	-	74	-23	1	100	H
2.925	26.78	MAv1	32.7	-20.5	2.04	41.02	54	-12.98	-	-	1	100	H
8.752	24.64	MAv1	36	-23.9	2.04	38.78	54	-15.22	-	-	1	100	V
8.755	36.14	PK2	36	-23.9	0	48.24	-	-	74	-15.76	1	100	V
13.685	34.86	PK2	38.8	-22.2	0	51.46	-	-	74	-22.54	1	100	V
13.686	23.88	MAv1	38.8	-22.2	2.04	42.52	54	-11.48	-	-	1	100	V

* - indicates frequency in 47 CFR §15.205/IC RSS-GEN §8.10 Restricted Band

PK2 - KDB558074 Method: Maximum Peak

MAv1 - KDB558074 Option 1 Maximum RMS Average

9.2. WORST-CASE BELOW 1 GHz

SPURIOUS EMISSIONS 30 TO 1000 MHz (WORST-CASE CONFIGURATION)

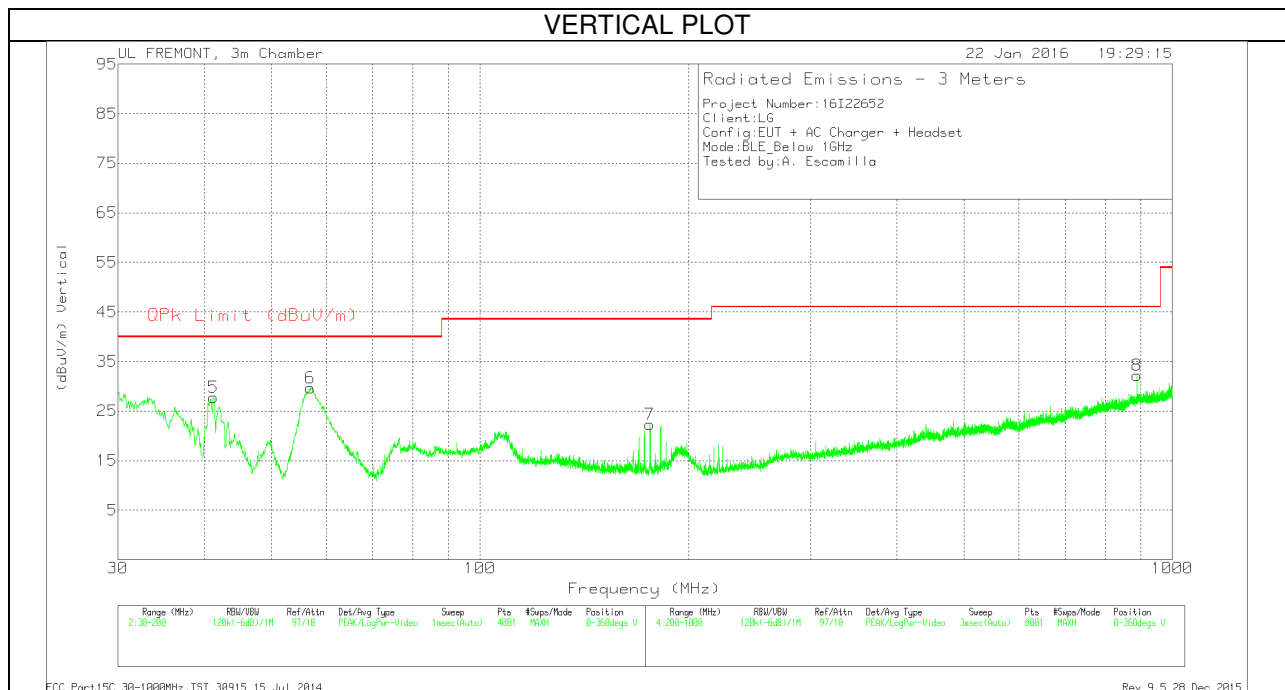
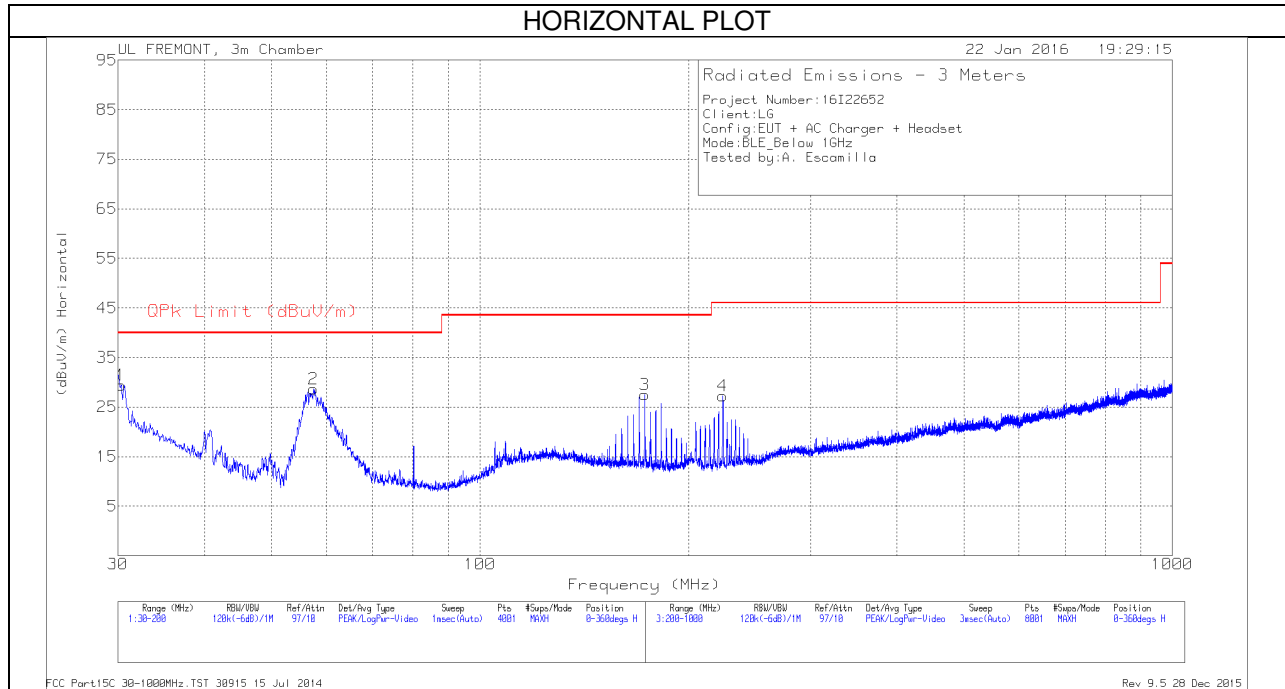

BELOW 1 GHz TABLE

Marker	Frequency (MHz)	Meter Reading (dBuV)	Det	AF T130 (dB/m)	Amp/Cbl (dB)	Corrected Reading (dBuV/m)	QPk Limit (dBuV/m)	Margin (dB)	Azimuth (Degs)	Height (cm)	Polarity
1	30.2975	35.16	Pk	21.5	-27.2	29.46	40	-10.54	0-360	100	H
5	41.22	41.5	Pk	13.3	-27	27.8	40	-12.2	0-360	100	V
6	56.9025	49.51	Pk	7.1	-26.9	29.71	40	-10.29	0-360	100	V
2	57.4763	48.41	Pk	7.1	-26.9	28.61	40	-11.39	0-360	300	H
3	172.97	41.57	Pk	11.4	-25.5	27.47	43.52	-16.05	0-360	300	H
7	175.9875	36.47	Pk	11.2	-25.4	22.27	43.52	-21.25	0-360	100	V
4	224.3	41.42	Pk	10.7	-24.9	27.22	46.02	-18.8	0-360	100	H
8	888.9	32.87	Pk	22.1	-22.8	32.17	46.02	-13.85	0-360	100	V

* - indicates frequency in 47 CFR §15.205/IC RSS-GEN §8.10 Restricted Band

Pk - Peak detector