

On your side

**HCT**

# TEST REPORT

EMI Test for FCC Certification of LM-K200TM Model

APPLICANT

LG Electronics USA, Inc.

REPORT NO.

HCT-EM-2009-FC006-R1

DATE OF ISSUE

October 15, 2020

Tested by  
Ki-Min Lee

(signature)

Technical Manager  
Jeong-Hyun Choi

(signature)

HCT Co., Ltd.

74, Seoicheon-ro 578beon-gil, Majang-myeon, Icheon-si, Gyeonggi-do, 17383 KOREA

Tel. +82 31 645 6300 Fax. +82 31 645 6401



HCT Co., Ltd.

74, Seoicheon-ro 578beon-gil, Majang-myeon, Icheon-si, Gyeonggi-do, 17383 KOREA  
Tel. +82 31 645 6300 Fax. +82 31 645 6401

<h1 style="margin: 0;">TEST REPORT</h1> <p style="margin: 0;">EMI Test for FCC Certification</p>	<p><b>REPORT NO.</b> HCT-EM-2009-FC006-R1</p> <p><b>DATE OF ISSUE</b> October 15, 2020</p> <p><b>FCC ID.</b> ZNFK200TM</p>
--	--

<b>Applicant</b>	<b>LG Electronics USA, Inc.</b> 111 Sylvan Avenue, North Building , Englewood Cliffs NJ 07632 United States
<b>Product Name</b>	Smart Phone
<b>Model Name</b>	LM-K200TM
<b>Date of Test</b>	August 27, 2020 to September 07, 2020
<b>Test Standard Used</b>	FCC CFR 47 PART 15 Subpart B Class B ANSI C63.4-2014
<b>Test Results</b>	Refer to the present document
<b>Manufacturer</b>	LG Electronics Inc.

The result shown in this test report refer only to the sample(s) tested unless otherwise stated.  
This test results were applied only to the test methods required by the standard.

## REVISION HISTORY

The revision history for this test report is shown in table.

Revision No.	Date of Issue	Description
0	September 24, 2020	Initial Release
1	October 15, 2020	Revised the frequency

The device bearing the trade name and model specified above, has been shown to comply with the applicable technical standards as indicated in the measurement report and was tested in accordance with the measurement procedures specified in ANSI C63.4-2014. (See Test Report if any modifications were made for compliance)  
I attest to the accuracy of data. All measurements reported herein were performed by me or were made under my supervision and are correct to the best of my knowledge and belief. I assume full responsibility for the completeness of these measurements and vouch for the qualifications of all persons taking them.  
HCT certifies that no party to application has been denied the FCC benefits pursuant to Section 5301 of the Anti-Drug Abuse Act of 1988, 21 U.S.C 862

The above Test Report is not related to the accredited test result by (KS Q) ISO/IEC 17025 and KOLAS (Korea Laboratory Accreditation Scheme) / A2LA (American Association for Laboratory Accreditation), which signed the ILAC-MRA.

\* The report shall not be reproduced except in full (only partly) without approval of the laboratory.

## CONTENTS

1. GENERAL INFORMATION	5
1.1 Description of EUT	5
1.2 Tested System Details	5
1.3 Cable Description	7
1.4 Noise Suppression Parts on Cable. (I/O Cable)	7
1.5 Test Facility	8
1.6 Calibration of Measuring Instrument	8
1.7 Measurement Uncertainty	9
2. DESCRIPTION OF TEST	10
2.1 Measurement of Conducted Emission	10
2.2 Measurement of Radiated Emission	11
2.3 Configuration of Tested System	12
3. PRELIMINARY TEST	13
3.1 Conducted Emission	13
3.2 Radiated Emission	13
4. CONDUCTED EMISSION AND RADIATED EMISSION TEST SUMMARY	14
4.1 Conducted Emission	14
4.2 Radiated Emission Below 1 GHz	19
4.3 Radiated Emission Above 1 GHz	21
5. CONCLUSION	23
6. APPENDIX A. TEST SETUP PHOTO	24

## 1. GENERAL INFORMATION

### 1.1 Description of EUT

<b>FCC ID</b>	ZNFK200TM
<b>Model Name</b>	LM-K200TM
<b>Product Name</b>	Smart Phone
<b>TX Frequency</b>	824.20 MHz to 848.80 MHz (GSM 850) 1 850.20 MHz to 1 909.80 MHz (GSM 1 900) 1 852.4 MHz to 1 907.6 MHz (WCDMA B2) 1712.4 MHz to 1752.6 MHz (WCDMA B4) 826.40 MHz to 846.60 MHz (WCDMA B5) 1 850 MHz to 1 910 MHz (LTE B2) 1 710 MHz to 1 755 MHz (LTE B4) 824 MHz to 849 MHz (LTE B5) 699 MHz to 716 MHz (LTE B12) 777 MHz to 787 MHz (LTE B13) 1 850 MHz to 1 915 MHz (LTE B25) 814 MHz to 849 MHz (LTE B26) 2 496 MHz to 2 690 MHz (LTE B41) 1 710 MHz to 1 780 MHz (LTE B66) 663 MHz to 698 MHz (LTE B71) 2 402 MHz to 2 480 MHz ( Bluetooth) 2 412 MHz to 2 462 MHz ( WiFi 2.4 GHz)
<b>RX Frequency</b>	869.20 MHz to 893.80 MHz (GSM 850) 1 930.20 MHz to 1 989.80 MHz (GSM 1 900) 1 932.4 MHz to 1 987.6 MHz (WCDMA B2) 2 112.4 MHz to 2 152.6 MHz (WCDMA B4) 871.40 MHz to 891.60 MHz (WCDMA B5) 1 930 MHz to 1 990 MHz (LTE B2) 2 110 MHz to 2 155 MHz (LTE B4) 869 MHz to 894 MHz (LTE B5) 729 MHz to 746 MHz (LTE B12) 746 MHz to 756 MHz (LTE B13) 1 925 MHz to 1 990 MHz (LTE B25) 859 MHz to 894 MHz (LTE B26) 2 496 MHz to 2 690 MHz (LTE B41) 2 110 MHz to 2 200 MHz (LTE B66) 617 MHz to 652 MHz (LTE B71) 2 402 MHz to 2 480 MHz ( Bluetooth) 2 412 MHz to 2 462 MHz ( WiFi 2.4 GHz)

## 1.2 Tested System Details

All equipment descriptions used in the tested system (including inserted cards) are:

Device Type	Model Name	Serial Number	Manufacturer
EUT	LM-K200TM	-	LG
Notebook PC	ProBook6560b	5CB2053MXF	HP
Notebook PC adaptor	Series PPP009L-E	-	LITE-ON TECHNOLOGY (CHANGZHOU)
Gateway	DIR-806M	-	D-Link
Gateway adaptor	AMS1-0501200FK	-	D-Link
Serial mouse	Serial 2 Button mouse	02031069	Radio Shack
RJ45 cable	-	-	-
DATA cable	EAD62377927	-	NINGBO
DATA cable	EAD62377922	-	KSD
DATA cable	EAD62377921	-	LEAGTECH
Earphone	EAB64468444	-	CRESYN
Micro SD card	Extreme MicroSDHC UHS-I CLASS 10 (32 GB)	-	SANDISK

### 1.3 Cable Description

Product Name	Port	Power Cord Shielded (Y/N)	I/O Cable Shielded (Y/N)	Length (m)
EUT	Micro USB	Y	Y	(P,D) 1.0
	Earphone	N/A	N	(D) 1.2
Notebook PC	RJ 45	N/A	N	(D) 1.6
	Serial(Mouse)	N/A	Y	(D) 1.8
	DC IN	N	N/A	(P) 1.8
Gateway	DC IN	N	N/A	(P) 1.8

NOTE. The marked "(D)" means the data cable and "(P)" means the power cable.

### 1.4 Noise Suppression Parts on Cable (I/O Cable)

Product Name	Port	Ferrite Bead (Y/N)	Location	Metal Hood (Y/N)	Location
EUT	Micro USB	N	N/A	Y	Both End
	Earphone	N	N/A	Y	EUT End
Notebook PC	RJ 45	N	N/A	N	N/A
	Serial(Mouse)	N	N/A	Y	Notebook PC End

### 1.5 Test Facility

Test site is located at 74, Seoicheon-ro 578beon-gil, Majang-myeon, Icheon-si, Gyeonggi-do, South Korea. Those measurement facilities are constructed in conformance with the requirements of ANSI C63.4-2014. The Normalized site attenuations (30 MHz to 1 GHz) and Site validation (1 GHz to 18 GHz) were performed in accordance with the standard in ANSI C63.4-2014

Measurement Facilities	Designation No.
Radiated Field strength measurement facility 3 m Semi Anechoic chamber	KR0032
Radiated Field strength measurement facility 10 m Semi Anechoic chamber #1	
Radiated Field strength measurement facility 10 m Semi Anechoic chamber #2	
Filing the EMI Measurement Facility (3 m Semi Anechoic Chamber and Shielded Room)	IC 5944A-4
Filing the EMI Measurement Facility (10 m Semi-Anechoic Chamber)	IC 5944A-2

### 1.6 Calibration of Measuring Instrument

The measuring equipment, which was utilized in performing the tests documented herein, has been calibrated in accordance with the manufacturers recommendations for utilizing calibration equipment, which is traceable to recognized national standards. Especially, all antenna for measurement is calibrated in accordance with the requirements of C63.5:2017



### 1.7 Measurement Uncertainty

The measurement uncertainties shown below were calculated in accordance with the requirements of ANSI C63.4-2014. All measurement uncertainty values are shown with a coverage factor of  $k = 2$  to indicate a 95 % level of confidence. The measurement data shown herein meets or exceeds the  $U_{CISPR}$  measurement uncertainty values specified in CISPR 16-4-2 and, thus, can be compared directly to specified limits to determine compliance.

Parameter	Expanded Uncertainty
Conducted Emission (0.15 MHz to 30 MHz)	1.58 dB
Radiated Emissions (30 MHz to 1 GHz)	4.86 dB
Radiated Emissions (1 GHz to 18 GHz)	4.58 dB
Radiated Emissions (18 GHz to 40 GHz)	5.54 dB

## 2. DESCRIPTION OF TEST

### 2.1 Measurement of Conducted Emission

The test procedure was in accordance with ANSI C63.4-2014, Clause 7.3

a. The EUT was placed 0.4 meters from the conducting wall of the shielded room with EUT being connected to the power mains through a line impedance stabilization network (LISN).

If the EUT is connected to the PC through USB, the AC power-line adapter of the PC is directly connected to a line impedance stabilization network (LISN).

Other support units were connected to the power mains through another LISN. The two LISNs provide 50 Ohm/ 50uH of coupling impedance for the measuring instrument.

b. Both conducted lines are measured in Quasi-Peak and Average mode, including the worst-case data points for each tested configuration.

c. The frequency range from 150 kHz to 30 MHz was searched.

#### Conducted Emission Limits

Frequency (MHz)	Resolution Bandwidth (kHz)	Class A		Class B	
		Quasi-Peak (dBμV)	Average (dBμV)	Quasi-Peak (dBμV)	Average (dBμV)
0.15 to 0.5	9	79	66	66 to 56*	56 to 46*
0.5 to 5	9	73	60	56	46
5 to 30	9	73	60	60	50

NOTE. Decreases with the logarithm of the frequency.

## 2.2 Measurement of Radiated Emission

The test procedure was in accordance with ANSI C63.4-2014, Clause 8.3

- a. The EUT was placed on the top of a turn table 0.8 meters above the ground at a semi-anechoic chamber. The table was rotated 360 degrees to determine the position of the highest radiation.
- b. The EUT was set 3 m away from the interference-receiving antenna, which was mounted on the top of a variable-height antenna tower.
- c. The antenna height is varied from 1 m to 4 m above the ground to determine the maximum value of the field strength. Both horizontal and vertical polarizations of the antenna are set to make the measurement.
- d. For each suspected emission, the EUT was arranged to its worst case and then the antenna was tuned to heights from 1 m to 4 m and the turn table was turned from 0 degrees to 360 degrees to find the maximum reading.
- e. The test-receiver system was set to Quasi-Peak detect function and specified bandwidth with maximum hold mode when the test frequency is below 1 GHz.
- f. The test-receiver system was set to Peak and Average detect function and specified bandwidth with maximum hold mode when the test frequency is above 1 GHz.
- g. Place the measurement antenna away from each area of the EUT determined to be a source of emissions at the specified measurement distance, while keeping the measurement antenna aimed at the source of emissions at each frequency of significant emissions, with polarization oriented for maximum response.  
(1 GHz to 40 GHz)

### Radiated Emission Limits

Frequency (MHz)	Class A			Class B		
	Antenna Distance (m)	Field Strength ( $\mu\text{V}/\text{m}$ )	Quasi-Peak ( $\text{dB}\mu\text{V}/\text{m}$ )	Antenna Distance (m)	Field Strength ( $\mu\text{V}/\text{m}$ )	Quasi-Peak ( $\text{dB}\mu\text{V}/\text{m}$ )
30 to 88	10	90	39.0	3	100	40.0
88 to 216	10	150	43.5	3	150	43.5
216 to 960	10	210	46.4	3	200	46.0
Above 960	10	300	49.5	3	500	54.0
Frequency (MHz)	Antenna Distance (m)	Class A		Class B		
		Peak ( $\text{dB}\mu\text{V}/\text{m}$ )	Average ( $\text{dB}\mu\text{V}/\text{m}$ )	Peak ( $\text{dB}\mu\text{V}/\text{m}$ )	Average ( $\text{dB}\mu\text{V}/\text{m}$ )	
Above 1 000	3	80	60	74	54	

### 2.2.1 Frequency Range of Radiated Measurements

An unintentional radiator, including a digital device, the spectrum shall be investigated from the lowest radio frequency signal generated or used in the device, without going below the lowest frequency for which a Radiated Emission limit is specified, up to the frequency shown in the following table

Highest frequency generated or used in the device or on which the device operates or tunes (MHz)	Upper frequency of measurement range (MHz)
Below 1.705	30
1.705 to 108	1 000
108 to 500	2 000
500 to 1 000	5 000
Above 1 000	5th harmonic of the highest frequency or 40 GHz, whichever is lower

### 2.3 Configuration of Tested System

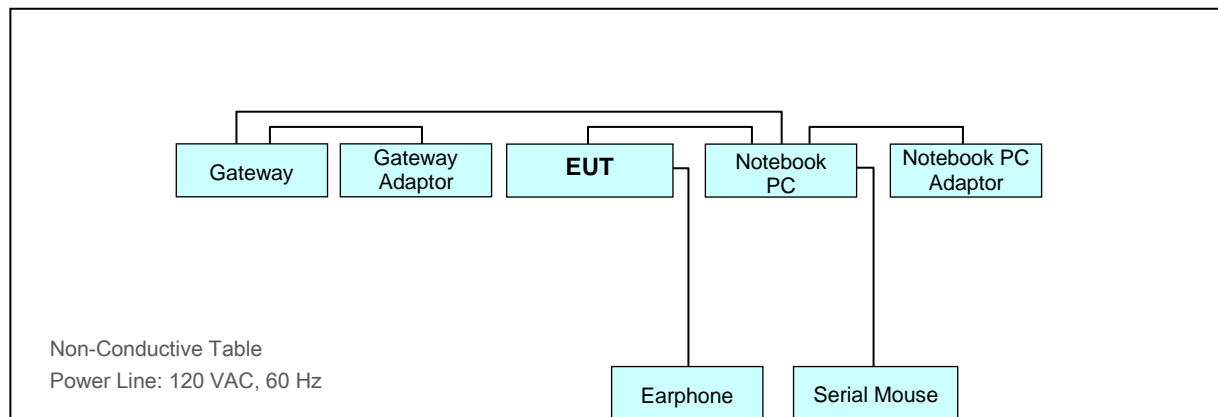

### 3. PRELIMINARY TEST

#### 3.1 Conducted Emission

It was tested the following operating mode, after connecting all peripheral devices.

**Operating Modes:** Data Communication mode

#### 3.2 Radiated Emission

It was tested the following operating mode, after connecting all peripheral devices.

**Operating Modes:** Data Communication mode

## 4. CONDUCTED EMISSION AND RADIATED EMISSION TEST SUMMARY

### 4.1 Conducted Emission

#### 4.1.1 Measuring instruments

	Type	Manufacturer	Model Name	Serial Number	Calibration Cycle	Calibration Date
<input checked="" type="checkbox"/>	EMI Test Receiver	Rohde & Schwarz	ESCI	100584	1 year	06.10.2020
<input checked="" type="checkbox"/>	LISN	Rohde & Schwarz	ENV216	102245	1 year	09.11.2019
<input type="checkbox"/>	LISN	Rohde & Schwarz	ENV216	102245	1 year	09.04.2020
<input checked="" type="checkbox"/>	LISN	Rohde & Schwarz	ENV216	100073	1 year	04.27.2020
<input checked="" type="checkbox"/>	Software	Rohde & Schwarz	EMC32	-	-	-

#### 4.1.2 Operating Condition

The test results of conducted emission at mains ports provide the following information:

Test Standard Used	FCC CFR 47 PART 15 Subpart B Class B ANSI C63.4-2014
Frequency Range	150 kHz to 30 MHz
Detector	Quasi-Peak, CISPR-Average
Bandwidth	9 kHz (6 dB)
Operating Mode	Data Communication mode
Worst Case of Data Cable	LEAGTECH (EAD62377921)
Kind of Test Site	EMI Shielded Room
Temperature	22.8 °C
Relative Humidity	48.3 %
Test Date	August 28, 2020

### 4.1.3 Measuring Data

Figure 1: Conducted Emission, AC Main Port, Line (L1)

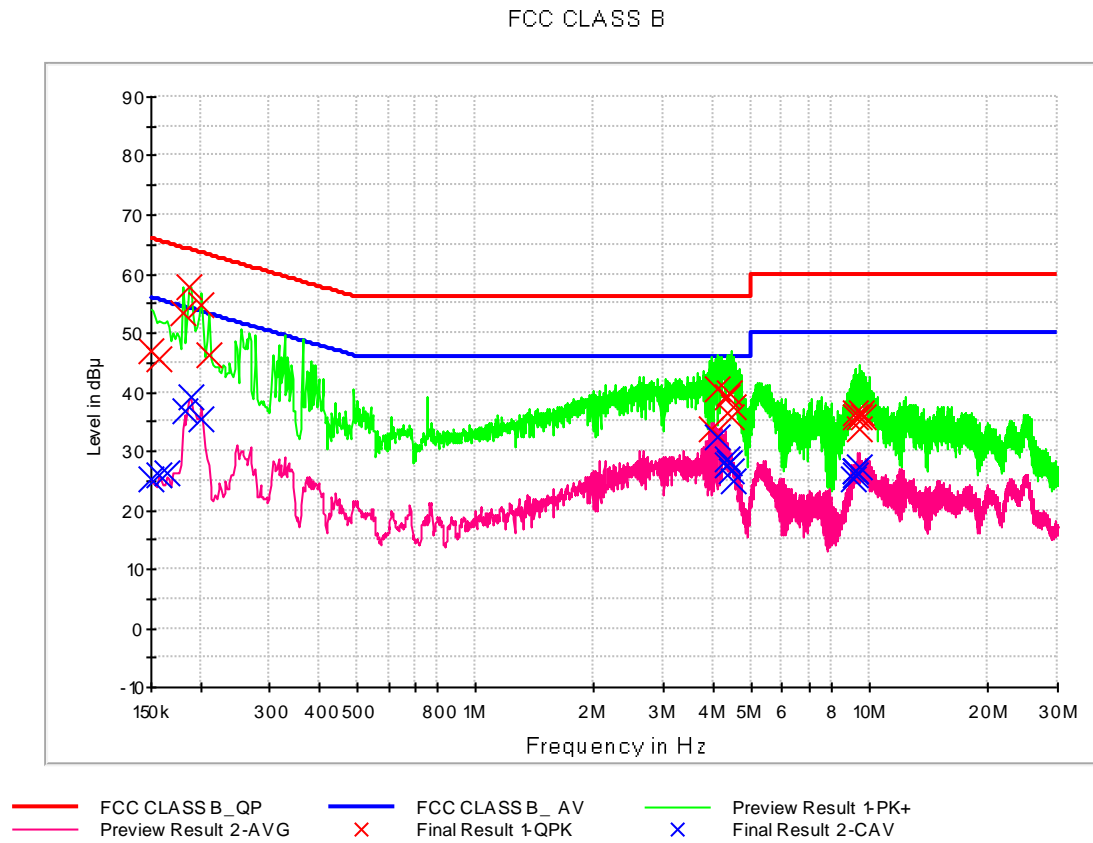

## Final Result 1

Frequency (MHz)	QuasiPeak (dBuV)	Bandwidth (kHz)	Line	Corr. (dB)	Margin (dB)	Limit (dBuV)
0.150000	46.8	9.000	L1	9.7	19.2	66.0
0.158000	45.6	9.000	L1	9.7	20.0	65.6
0.180000	53.4	9.000	L1	9.7	11.1	64.5
0.188000	57.7	9.000	L1	9.7	6.4	64.1
0.202000	54.6	9.000	L1	9.7	8.9	63.5
0.210000	46.4	9.000	L1	9.7	16.8	63.2
3.982000	33.8	9.000	L1	9.8	22.2	56.0
4.116000	40.5	9.000	L1	9.8	15.5	56.0
4.370000	39.3	9.000	L1	9.8	16.7	56.0
4.382000	39.8	9.000	L1	9.8	16.2	56.0
4.460000	35.8	9.000	L1	9.8	20.2	56.0
4.534000	37.6	9.000	L1	9.8	18.5	56.0
9.162000	35.7	9.000	L1	9.9	24.3	60.0
9.172000	36.4	9.000	L1	9.9	23.6	60.0
9.398000	35.9	9.000	L1	9.9	24.1	60.0
9.420000	33.6	9.000	L1	9.9	26.4	60.0
9.540000	36.4	9.000	L1	9.9	23.6	60.0
9.606000	35.7	9.000	L1	9.9	24.3	60.0

## Final Result 2

Frequency (MHz)	CAverage (dBuV)	Bandwidth (kHz)	Line	Corr. (dB)	Margin (dB)	Limit (dBuV)
0.150000	25.2	9.000	L1	9.7	30.8	56.0
0.158000	26.0	9.000	L1	9.7	29.5	55.6
0.164000	26.3	9.000	L1	9.7	28.9	55.3
0.182000	36.7	9.000	L1	9.7	17.7	54.4
0.190000	39.1	9.000	L1	9.7	15.0	54.0
0.202000	35.4	9.000	L1	9.7	18.1	53.5
4.116000	32.5	9.000	L1	9.8	13.5	46.0
4.332000	27.7	9.000	L1	9.8	18.3	46.0
4.354000	28.7	9.000	L1	9.8	17.3	46.0
4.382000	28.0	9.000	L1	9.8	18.0	46.0
4.460000	26.6	9.000	L1	9.8	19.4	46.0
4.510000	25.1	9.000	L1	9.8	20.9	46.0
9.150000	25.2	9.000	L1	9.9	24.8	50.0
9.158000	26.5	9.000	L1	9.9	23.5	50.0
9.162000	25.9	9.000	L1	9.9	24.1	50.0
9.166000	26.7	9.000	L1	9.9	23.3	50.0
9.172000	26.7	9.000	L1	9.9	23.3	50.0
9.440000	27.4	9.000	L1	9.9	22.6	50.0

### Calculation Formula:

1. Conductor L1 = Hot, Conductor N = Neutral
2. Corr. = LISN Factor + Cable Loss
3. QuasiPeak or CAverage = Receiver Reading + Corr.
4. Margin = Limit – QuasiPeak or CAverage



Figure 2: Conducted Emission, AC Main Port, Line (N)

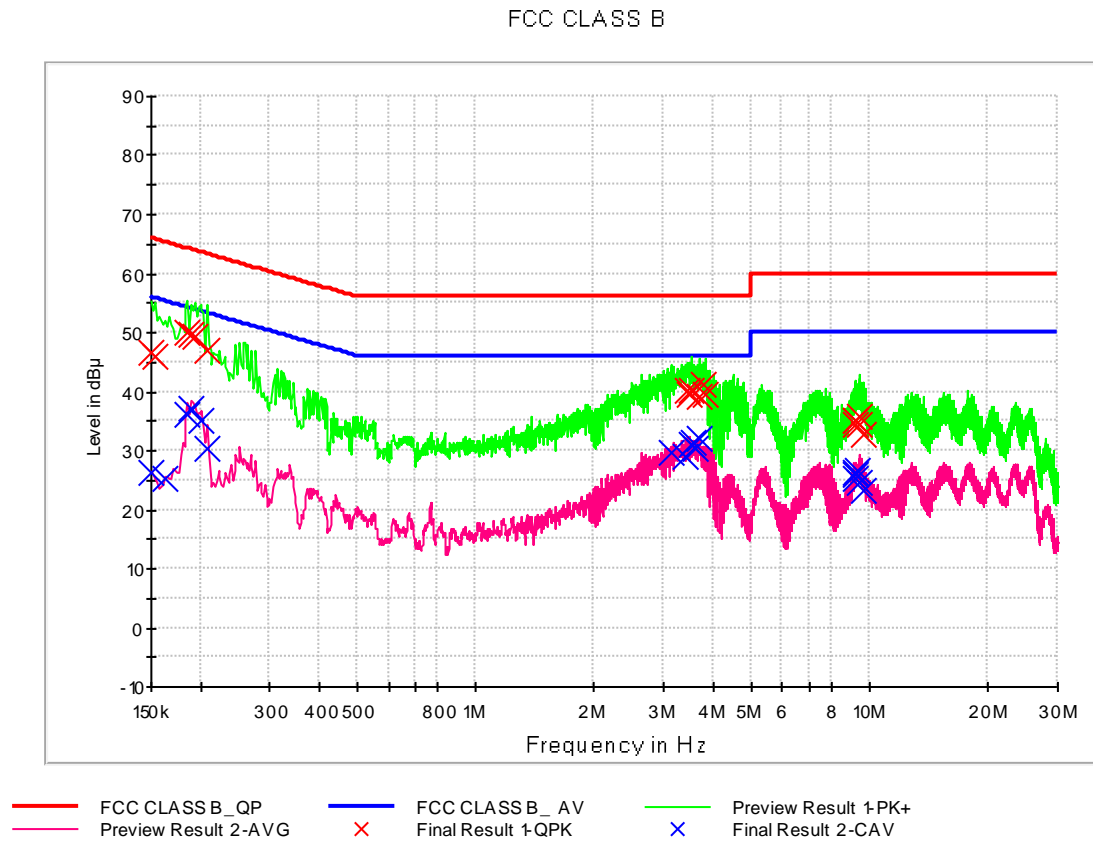

## Final Result 1

Frequency (MHz)	QuasiPeak (dBuV)	Bandwidth (kHz)	Line	Corr. (dB)	Margin (dB)	Limit (dBuV)
0.150000	46.6	9.000	N	9.7	19.4	66.0
0.154000	46.1	9.000	N	9.7	19.7	65.8
0.186000	49.9	9.000	N	9.7	14.3	64.2
0.190000	49.8	9.000	N	9.7	14.3	64.0
0.194000	49.4	9.000	N	9.7	14.4	63.9
0.208000	47.0	9.000	N	9.7	16.3	63.3
3.460000	40.1	9.000	N	9.8	15.9	56.0
3.504000	39.6	9.000	N	9.8	16.4	56.0
3.538000	40.2	9.000	N	9.8	15.8	56.0
3.682000	39.1	9.000	N	9.8	16.9	56.0
3.800000	41.2	9.000	N	9.8	14.8	56.0
3.814000	39.4	9.000	N	9.8	16.6	56.0
9.196000	35.0	9.000	N	9.9	25.0	60.0
9.236000	34.5	9.000	N	9.9	25.5	60.0
9.258000	35.1	9.000	N	9.9	24.9	60.0
9.380000	34.3	9.000	N	9.9	25.7	60.0
9.398000	35.6	9.000	N	9.9	24.4	60.0
9.608000	32.7	9.000	N	9.9	27.3	60.0

## Final Result 2

Frequency (MHz)	CAverage (dBuV)	Bandwidth (kHz)	Line	Corr. (dB)	Margin (dB)	Limit (dBuV)
0.150000	26.3	9.000	N	9.7	29.7	56.0
0.162000	25.1	9.000	N	9.7	30.3	55.4
0.186000	36.2	9.000	N	9.7	18.0	54.2
0.190000	37.2	9.000	N	9.7	16.9	54.0
0.202000	35.1	9.000	N	9.7	18.4	53.5
0.208000	30.5	9.000	N	9.7	22.8	53.3
3.122000	29.7	9.000	N	9.8	16.3	46.0
3.400000	29.1	9.000	N	9.8	16.9	46.0
3.538000	31.0	9.000	N	9.8	15.0	46.0
3.558000	31.5	9.000	N	9.8	14.5	46.0
3.610000	30.3	9.000	N	9.8	15.7	46.0
3.694000	32.2	9.000	N	9.8	13.8	46.0
9.196000	25.3	9.000	N	9.9	24.7	50.0
9.254000	26.0	9.000	N	9.9	24.0	50.0
9.258000	26.3	9.000	N	9.9	23.7	50.0
9.360000	26.5	9.000	N	9.9	23.5	50.0
9.432000	24.6	9.000	N	9.9	25.4	50.0
9.608000	23.3	9.000	N	9.9	26.7	50.0

## 4.2 Radiated Emission Below 1 GHz

### 4.2.1 Measuring instruments

Type	Manufacturer	Model Name	Serial Number	Calibration Cycle	Calibration Date
<input checked="" type="checkbox"/> EMI test receiver	Rohde & Schwarz	ESU40	100524	1 year	05.12.2020
<input checked="" type="checkbox"/> Bi-Log antenna	Schwarzbeck	VULB 9168	255	2 year	03.26.2019
<input checked="" type="checkbox"/> Antenna master	INNCO Systems	MA4640-XP-ET	-	N/A	-
<input checked="" type="checkbox"/> Antenna master controller	INNCO Systems	CO3000	CO3000/870/ 35990515/L	N/A	-
<input checked="" type="checkbox"/> Turn table	INNCO Systems	1060	-	N/A	-
<input checked="" type="checkbox"/> Turn table controller	INNCO Systems	CO2000	CO2000/095/ 7590304/L	N/A	-
<input checked="" type="checkbox"/> Software	Rohde & Schwarz	EMC32	-	-	-

### 4.2.2 Operating Condition

The test results of radiated emission provide the following information:

Used Test Standard	FCC CFR 47 PART 15 Subpart B Class B ANSI C63.4-2014
Frequency Range	30 MHz to 1 000 MHz
Detector	Quasi-Peak
Bandwidth	120 kHz (6 dB)
Operating Mode	Data Communication mode
Worst Case of Data Cable	LEAGTECH (EAD62377921)
Kind of Test Site	3 m semi anechoic chamber
Temperature	22.7 °C
Relative Humidity	44.5 %
Test Date	August 27, 2020

## 4.2.3 Measuring Data

Frequency (MHz)	Quasi Peak (dB $\mu$ V/m)	Antenna Height (cm)	POL. (H/V)	Azimuth (deg)	Corr. (dB)	Margin (dB)	Limit (dB $\mu$ V/m)
30.156000	28.4	100.0	V	55.0	18.3	11.6	40.0
56.265000	24.1	100.0	V	0.0	19.5	15.9	40.0
80.000000	32.9	207.7	H	96.0	15.6	7.1	40.0
132.823280	28.4	100.0	V	267.0	18.4	15.1	43.5
187.097880	28.0	174.7	H	105.0	17.7	15.5	43.5
266.627280	32.8	125.0	H	146.0	19.3	13.2	46.0

## - Calculation Formula:

1. POL. H = Horizontal, POL. V = Vertical
2. QuasiPeak = Reading (Receiver Reading) + Corr.
3. Corr. (Correction Factor) = Antenna Factor + Cable Loss
4. Margin = Limit - QuasiPeak

### 4.3 Radiated Emission Above 1 GHz

#### 4.3.1 Measuring instruments

	Type	Manufacturer	Model Name	Serial Number	Calibration Cycle	Calibration Date
<input checked="" type="checkbox"/>	EMI test receiver	Rohde & Schwarz	ESU40	100524	1 year	05.12.2020
<input checked="" type="checkbox"/>	Antenna master	INNCO Systems	MA4640-XP-ET	-	N/A	-
<input checked="" type="checkbox"/>	Antenna master controller	INNCO Systems	CO3000	CO3000/870/ 35990515/L	N/A	-
<input checked="" type="checkbox"/>	Turn table	INNCO Systems	1060	-	N/A	-
<input checked="" type="checkbox"/>	Turn table controller	INNCO Systems	CO2000	CO2000/095/ 7590304/L	N/A	-
<input checked="" type="checkbox"/>	Low noise amplifier	TESTEK	TK-PA18H	170034-L	1 year	03.03.2020
<input type="checkbox"/>	Low noise amplifier	TESTEK	TK-PA1840H	170030-L	1 year	02.13.2020
<input type="checkbox"/>	Horn antenna	Schwarzbeck	BBHA 9120D	1641	1 year	06.24.2020
<input checked="" type="checkbox"/>	Horn antenna	Schwarzbeck	BBHA 9120D	01836	1 year	07.23.2020
<input type="checkbox"/>	Horn antenna	Schwarzbeck	BBHA 9170	BBHA9170#786	1 year	12.03.2019
<input checked="" type="checkbox"/>	Software	Rohde & Schwarz	EMC32	-	-	-

#### 4.3.2 Operating Condition

The test results of radiated emission provide the following information:

Used Test Standard	FCC CFR 47 PART 15 Subpart B Class B ANSI C63.4-2014
Detector	Peak mode: Peak (RBW: 1 MHz, VBW: 3 MHz) CISPR-Average mode: Peak (RBW: 1 MHz, VBW: 10 Hz)
Highest Frequency	2 690 MHz
Tested Frequency Range	1 GHz to 18 GHz
Operating Mode	Data Communication mode
Worst Case of Data Cable	LEAGTECH (EAD62377921)
Kind of Test Site	3 m semi anechoic chamber
Temperature	23.5 / 23.9 °C
Relative Humidity	45.6 / 44.1 %
Test Date	September 04 / September 07, 2020

## 4.3.3 Measuring Data

Frequency (MHz)	Peak (dB $\mu$ V/m)	Antenna Height (cm)	POL. (H/V)	Azimuth (deg)	Corr. (dB)	Margin (dB)	Limit (dB $\mu$ V/m)
1329.500000	42.2	219.4	V	185.0	-28.1	31.8	74.0
1996.745000	50.0	100.0	V	47.0	-26.4	24.0	74.0
2589.010000	51.4	290.5	V	63.0	-23.8	22.6	74.0
2660.605000	46.3	150.0	V	4.0	-23.5	27.7	74.0
4480.920000	41.2	206.6	V	4.0	-19.2	32.8	74.0
17982.272030	55.2	261.4	H	103.0	9.4	18.8	74.0

Frequency (MHz)	CAverage (dB $\mu$ V/m)	Antenna Height (cm)	POL. (H/V)	Azimuth (deg)	Corr. (dB)	Margin (dB)	Limit (dB $\mu$ V/m)
1329.500000	25.2	219.4	V	185.0	-28.1	28.8	54.0
1996.745000	33.9	100.0	V	47.0	-26.4	20.1	54.0
2589.010000	32.0	290.5	V	63.0	-23.8	22.0	54.0
2660.605000	28.2	150.0	V	4.0	-23.5	25.8	54.0
4480.920000	25.2	206.6	V	4.0	-19.2	28.8	54.0
17982.272030	42.7	261.4	H	103.0	9.4	11.3	54.0

## - Calculation Formula:

1. POL. H = Horizontal, POL. V = Vertical
2. Peak or CAverage = Reading (Receiver Reading) + Corr.
3. Corr. (Correction Factor) = Antenna Factor+ Cable Loss –Amplifier Gain
4. Margin = Limit - Peak or CAverage

## 5. CONCLUSION

The data collected shows that the **Product Name: Smart Phone / Model Name: LM-K200TM** complies with §15.107 and §15.109 of the FCC rules.

## 6. APPENDIX A. TEST SETUP PHOTO

Please refer to Appendix. A and test setup photo file no. as follows;

<b>File No.</b>	<b>Date of Issue</b>	<b>Description</b>
HCT-EM-2009-FC006-P	September 24, 2020	Initial Release

End of report